

Cardiac Resuscitation

Examining rural heartland development through an ecological lens



Cardiac Resuscitation:

Examining rural heartland development through an ecological lens

By

Jay D. Anderson

A Terminal Project

Presented to the Faculty of

The College of Architecture at the University of Nebraska

In Partial Fulfillment of Master of Architecture

Major: Architecture

Under the supervision of the professor

Martin Despang

Lincoln, Nebraska May 2008





ABSTRACT

Throughout southwest Iowa, prime farm land is being sold and then purchased by local real estate developers. These developers are creating housing clusters throughout the countryside, especially in the rural Loess Hills area. These housing clusters have similar covenant restrictions imposed by the developers, but few if any address larger and more critical architectural, social, environmental and ecological issues. Recently one of these developers purchased some land from my family for this very reason. Knowing what will happen to this land, I chose to devote my efforts in order to provide a better, more eco-friendly solution to the inevitable consequences which will transform this land.

BACKGROUND

We spend 90% of our time indoors, and of that 90% most of it is within our own home. Our home says a lot about who we are, our beliefs, our financial situation, and our dedication. Our homes are extensions of us, so much so that we actually feel emotional and physical pain when taken away or destroyed. Throughout history we have fought and even died for our homes, because our homes are where we live, where we play, where we come back to when we need comfort.

Homes are like people; some are large, others are small. Some homes are old and require a lot of maintenance and care, while others are new require very little. Our homes can bring us an immense sense of pride, while other can bring shame. It's safe to say that our homes have an impact on us as a society, but they also have an impact on the environment. Homes like people require resources to exist, many of which are finite. This begs the question, if homes are a lot like people and people have the ability to change the environment; shouldn't our homes have that same ability?

Ponder this; if one person goes out and builds a home that responds to the context in which it's built, has a positive impact on the environment, is aesthetically appealing and could actually save the owner money would anyone notice? Well what if a group of like-minded people got together and built a small community of these homes, would anyone notice then? Let's take it to the next level and say that in addition to those homes, people wanted the buildings in which they worked have the same attributes as their homes, then would anyone notice? Finally, what if instead of having huge, energy-hungry houses and poor working conditions, people demanded that every place be just like their home?

The point is that it all starts with the place in which we feel the most comfortable, the place where we feel the safest, and the place which represents us... our home. If we design our homes so that they work with nature instead of competing against it, then nature will no longer be just a vague term of what we all want to experience, it will simply be the way we live.

OBJECTIVES

As long as the United States is dependent on foreign oil, many aspects of society will remain static. Architects have the duty and the ability to change certain aspects of our society, beginning on a personal level. The home where people live is perhaps one of the most personal environments and tools architects can use to educate the public and bring clarity to the issues facing most people. Architects have lost ground in the housing market to other building entities, however it is not too late to take the lead and provide solutions that can benefit all of humanity.



Table of Contents

1. Intent
2. Case Studies
 - Waubonsie Ridge
 - Field View
12. Site Analysis
26. Precedent Studies
 - James Howard Kunstler
 - La Luz
 - Fredensborg Houses
 - Magney House
 - Fletcher-Page House
 - Country House
 - Jacobs House II
 - Nevogilde House I
 - Alcanena House
 - Baiao House
 - Monol House
 - Maison Domino
62. Process
 - Solutions
 - Sketches
 - Concepts & Prototypes
 - Schematic Design
120. Final Design
 - Berm Home
 - Earth Home
 - Treetop Home
148. Bibliography
150. Acknowledgements

INTENT

- The intent of this project is to examine previously developed rural clusters in southwest Iowa and critically analyze the ways in which they operate and affect their surroundings.
- The first step is to document and analyze the physical sites of these clusters, but also individual dwelling units within the rural clusters themselves. By doing this, a greater understanding of the negative aspects can be determined.
- During the investigation, perceived negative issues will be examined and documented for further analysis and comprehension.
- Next an investigation of several precedents will be done. The precedents are situated in a similar contextual manner to the existing rural clusters and will be critically analyzed to determine the successful aspects of them.
- The product of this research will be used to make appropriate and intelligent design decisions for the building site in question.
- Finally, a series of prototype houses will be developed that respond to the issues of today, and those of a post-fossil era. These housing prototypes will be a response to the types of housing clusters being built throughout rural areas in southwest Iowa.



Case Studies

In order to determine the true issues at hand, case studies were performed in the area, and of the exact developer which purchased the site in question. Two developments were chosen as case studies. Waubonsie ridge, located to the south of the site, and Field View which is located to the north. Both are typical responses to how a traditional developer would go about solving the desire for housing in a rural area.

Each development was closely examined as to how each was arranged, the site conditions, the demographics of the occupants and the covenants by which they are governed. After analyzing each development, a summary of a typical dwelling on that site was created which highlights the negative yet common aspects of their design.



FOR SALE



**JIM
HUGHES**

REAL ESTATE

(712) 527-3114

jimhughesrealestate.com

Waubonsie Ridge

Sidney, IA 2004-2006

Waubonsie Ridge is a 500 acre, 25 lot site in rural Southwest, IA. The site is directly adjacent to Waubonsie state park, and only 25 minutes from the Omaha-metro area. The combination of scenic views and proximity to major city and interstate infrastructure make it attractive for those wishing to move from the city to the country. This development is a typical rural development which replaces prime farmland with housing clusters. The result is a set of dwellings have little to no regard for their surroundings.

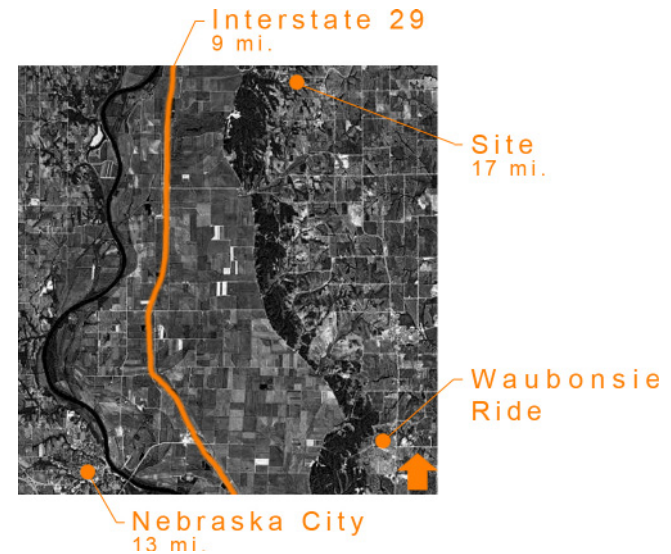

Waubonsie Ridge

Sidney, IA 2004-2006

Even though this cluster had to comply with the Iowa DNR's discharge rates and erosion control, it does not address its surroundings, solar orientation, rain-water retention or promote true architectural diversity.

number of lots: 25
lot size: 2-9 acres
size: 1300 s.f. 1-story
1800 s.f 2-story



Waubonsie Ridge

Sidney, IA 2004-2006

dark roof absorbs heat
increasing cooling loads

no windows to accept
southern breezes

no protection from
north winter winds

north-south orientation
increases heat gain

turf grass requires
extensive irrigation



impervious coverage
increases run-off
rates and volume

Waubonsie Ridge

(analysis)

Waubonsie Ridge was the first rural cluster done by this particular developer. The type of construction is typical to not only rural clusters but also of the region. The architecture does not lend itself well to the potential of a power outage or adverse climatic affects. The covenants governing this particular site do not allow the use of any photovoltaic or wind turbine technologies to be seen or constructed on the lots. There were several issues of not only the dwellings themselves, but the site as a whole which negatively affect performance and occupant comfort.

- lack of protection from northern winter winds.
- north-south orientation allows for intense late-day excess heat gain.
- turf grass, which is not native to the area requires additional watering during dry periods.
- dark roofing materials which absorbs heat intense summer heat and requires additional cooling to compensate.
- no windows to the south to accept southern breezes or beneficial solar gain in the winter months.
- large amounts of impervious coverage such as asphalt and concrete are used extensively on the site, which contributes to increased run-off rates, volumes and heat islands.
- no natural forms of shading anywhere close to the dwellings.

Field View

Tabor, IA 2006-2007

Field View is a 54 acre, 12 lot site along Highway 275. The site is located 2 miles North of Tabor, IA and approximately 15 minutes from the Omaha-metro area. The site like Waubonsie Ridge has taken prime farmland and replaced it with individual lots. Each lot runs in the east-west direction and is void of any trees which could provide shade from the sun and protection from winds.

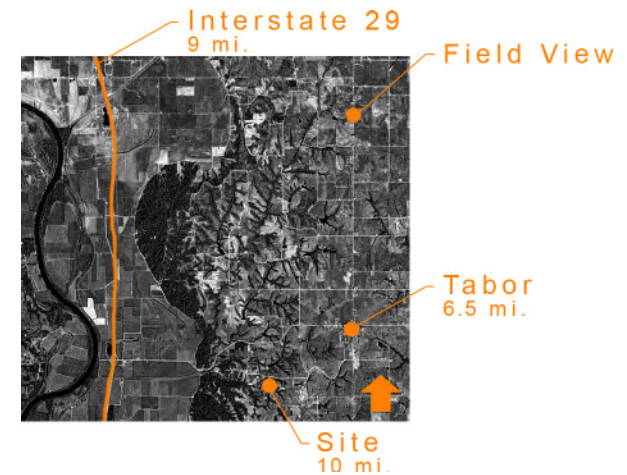

Field View

Tabor, IA 2006-2007

The development is governed by the same restrictions as Waubonsie Ridge, however, each lot is the same size. All the houses currently face east-west, which have a negative impact during the summer months due to solar heat gain. The houses are typical of those found in the mid-west and there are no covenants for this development.

number of lots: 12

lot size: 4 acres

size: 1800 s.f. 1-story

2800 s.f 2-story

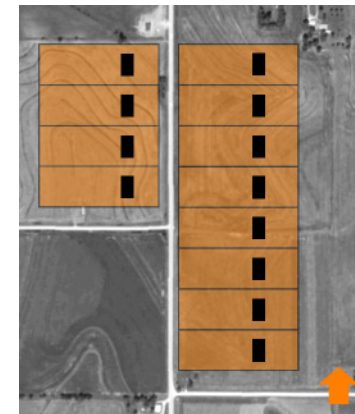

Field View

Tabor, IA 2006-2007

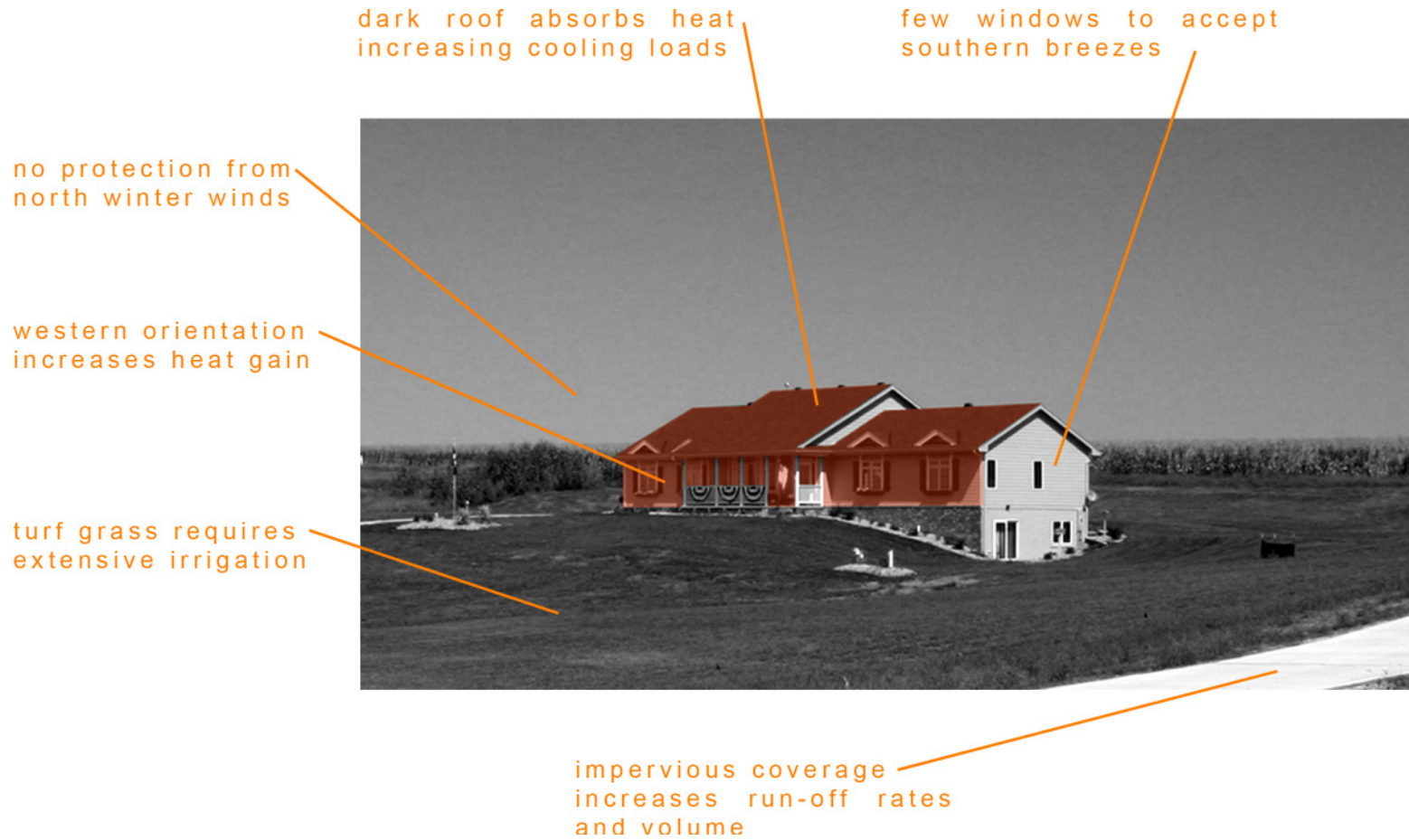

Field View

(analysis)

Field View was the second rural cluster done by this particular developer. The type of construction is typical to not only rural clusters but also of the region. The architecture does not lend itself well to the potential of a power outage or adverse climatic affects. The covenants governing this particular site are the same as Waubonsie Ridge, and do not allow the use of any photovoltaic or wind turbine technologies to be seen or constructed on the lots. This site, like Waubonsie Ridge was previously prime farmland.

- lack of protection from northern winter winds.
- north-south orientation allows for intense late-day excess heat gain.
- turf grass, which is not native to the area requires additional watering during dry periods.
- dark roofing materials which absorbs heat intense summer heat and requires additional cooling to compensate.
- few windows to the south to accept southern breezes or beneficial solar gain in the winter months.
- large amounts of impervious coverage such as asphalt and concrete are used extensively on the site, which contributes to increased run-off rates, volumes and heat islands.
- no natural forms of shading anywhere close to the dwellings.

Site Analysis

To know what design decisions will be appropriate for the proposed dwellings, an extensive analysis of the site in question must be performed. Factors to consider are; origin, proximities, travel to and from the site, site access, available local services, utility access, amenities, slope, climatic data, and overall site condition.

Upon gathering this information it will be possible to determine what solutions will be beneficial for the dwellings on the site.



Site Analysis

(loess origin)

The loess hills (pronounced like LUSS) are located in western Iowa and to a lesser extent, in eastern Nebraska. The hills are composed of yellow loess soil overlying older debris left from the last ice age. They are characterized by sharp edged ridge crests, and slopes ranging from gentle to very steep. Cliffs cut into the erosion resistant soil by rivers, streams or road builders a hundred years ago still remain.

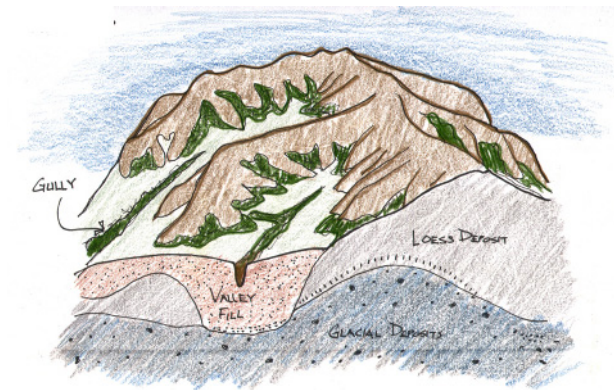

Site Analysis

(proximities)

The site is located 2.6 miles from the small town of Tabor, IA. The closest interstate access is 7 miles to the east via paved scenic byways. Omaha, the major metro area of the region is located 36 miles to the northwest via Interstate 29.

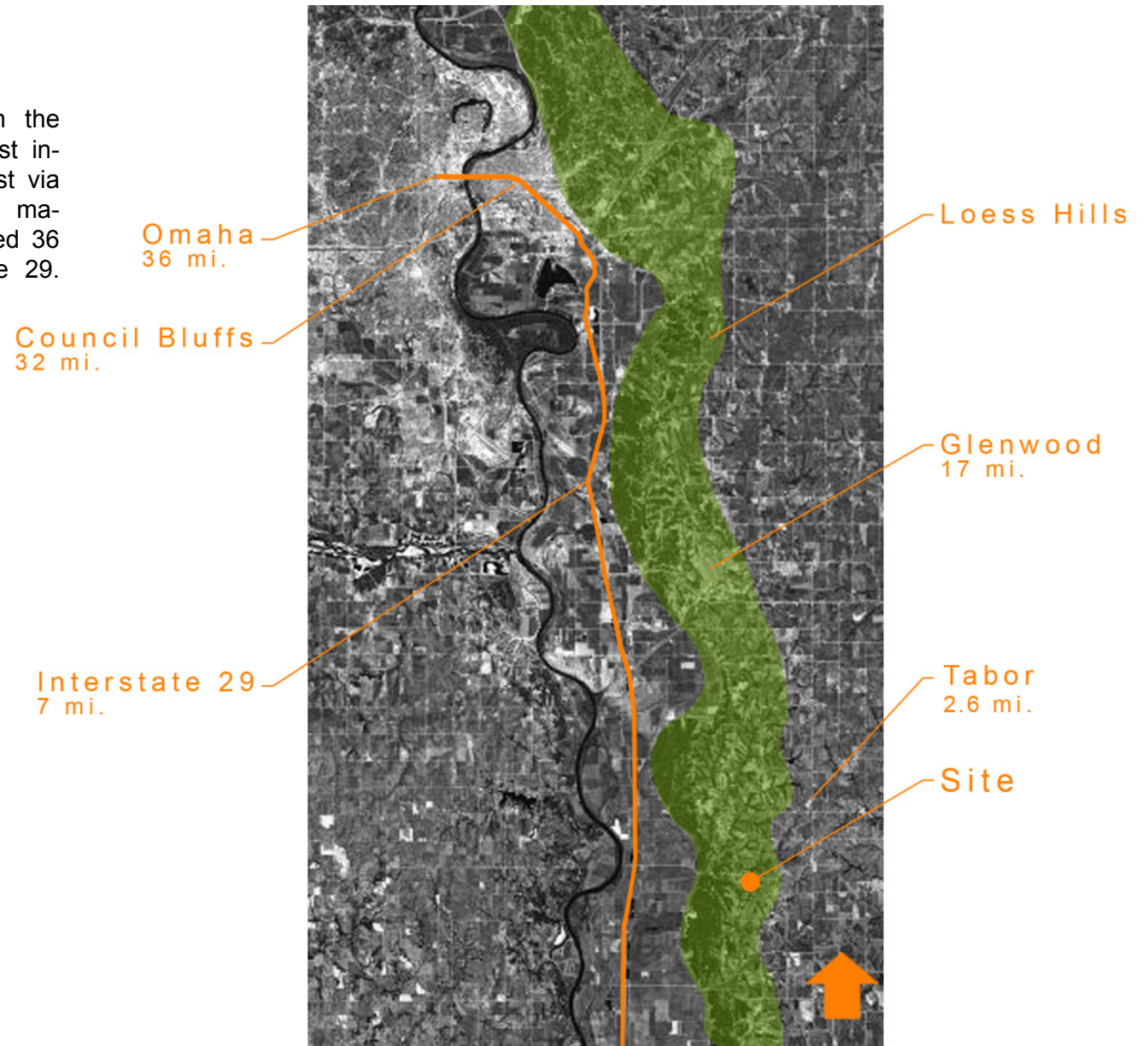

Site Analysis

(travel from site)

The map on this page shows the distance and travel time from the site to a theoretical office located in downtown Omaha.

The map on opposite page shows the distance and travel time from a typical house in Elkhorn, to a theoretical office in downtown Omaha. Elkhorn was chosen as a theoretical residence because it encompasses many of the same desired qualities of the project site.

It is obvious to see that travel from a typical suburban house in Elkhorn is only 19.1 miles from the office, yet due to traffic congestion and all too common construction, it takes twice as long to get to as someone traveling from the rural site. Travel times, scenic areas, lower taxes and privacy are only a few of the reasons people are choosing to move from suburbia and into rural communities in the region.

Distance: 35.4 mi.
Time: 25 min.



Site Analysis

(travel from elkhorn)

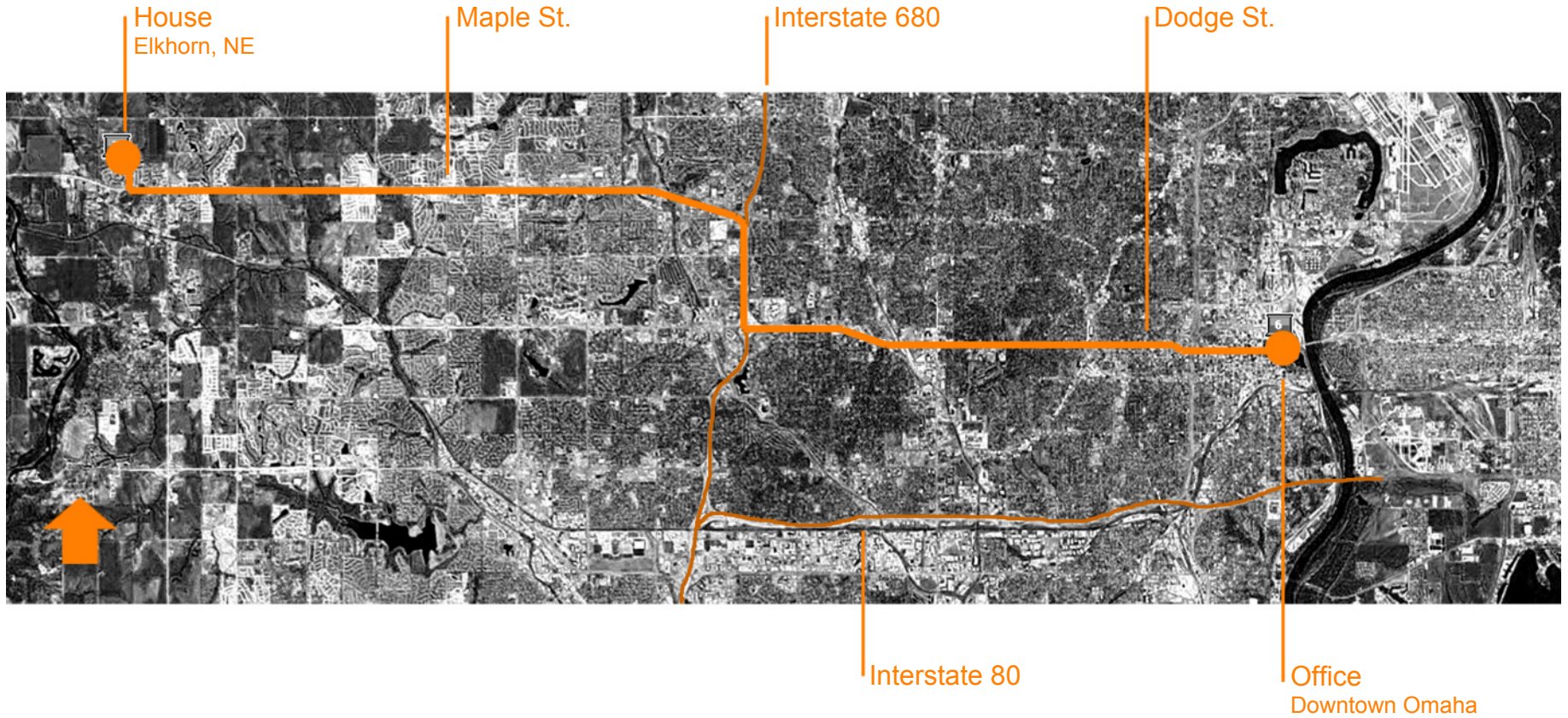

Distance: 19.1 mi.
Time: 49 min.

Site Analysis

(site amenities)

Advantages:

- proximity to town
- aesthetics
- southern exposure
- privacy
- "lot" size
- geothermal/solar/wind
- fewer restrictions
- less traffic & crime
- less "heat island"

Disadvantages:

- septic system
- exposure (wind)
- security
- limited accessibility
- isolation from services
- potential sprawl
- road maintenance
- lack of community connectivity

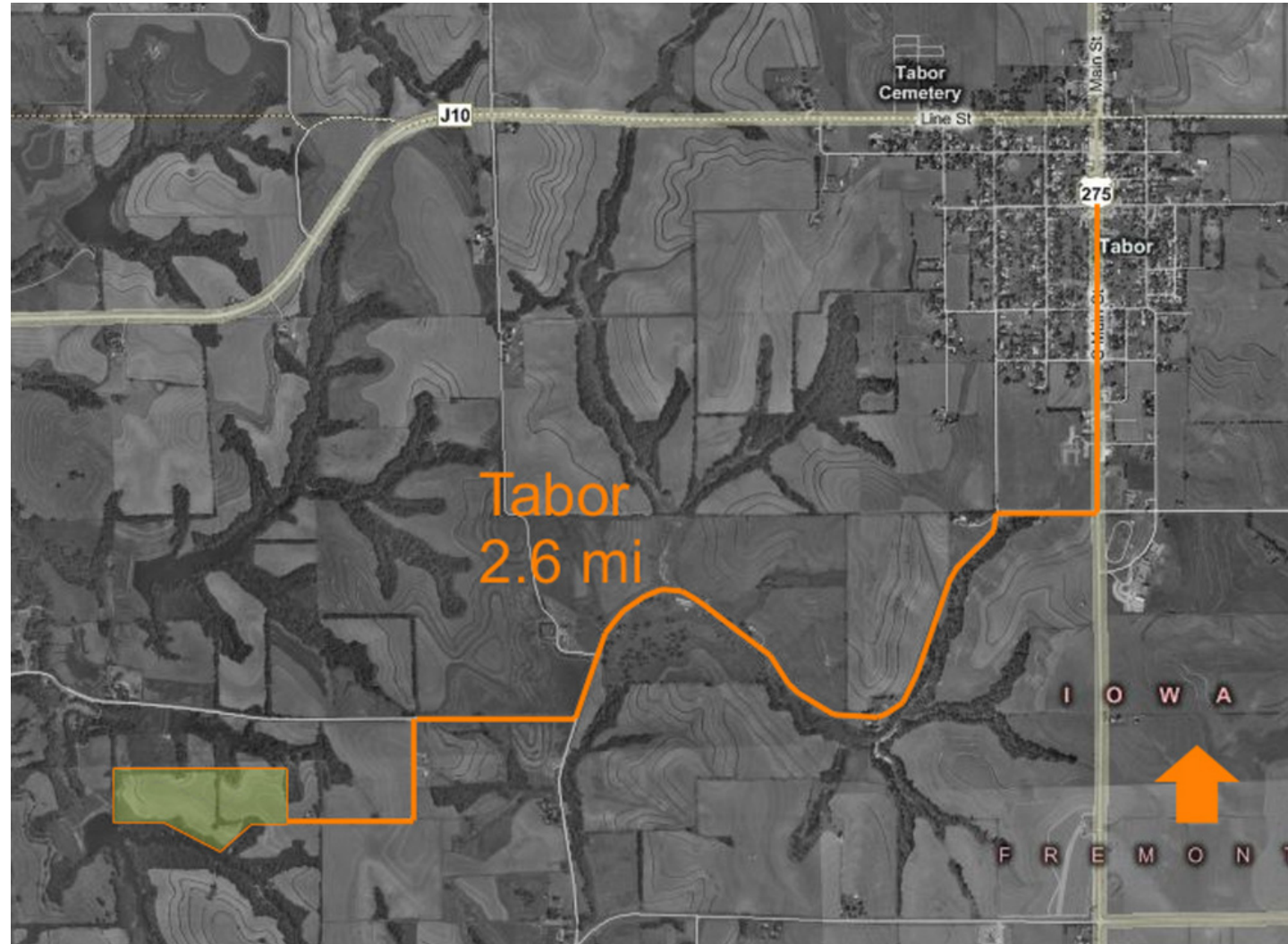

Site Analysis (service radii)

20 miles

airport
nursery

10 miles

hospital
dentist
optometrist
sheriff
courthouse
fairgrounds
golf course
clothing store
market

30 miles

major metro
large airport

5 miles

grocery
church
library
fire/rescue
k-12 school
bank / post office
gas station
mechanic
restaurant
nursing home
lumber yard
daycare
stone quarry
interstate access
rail line

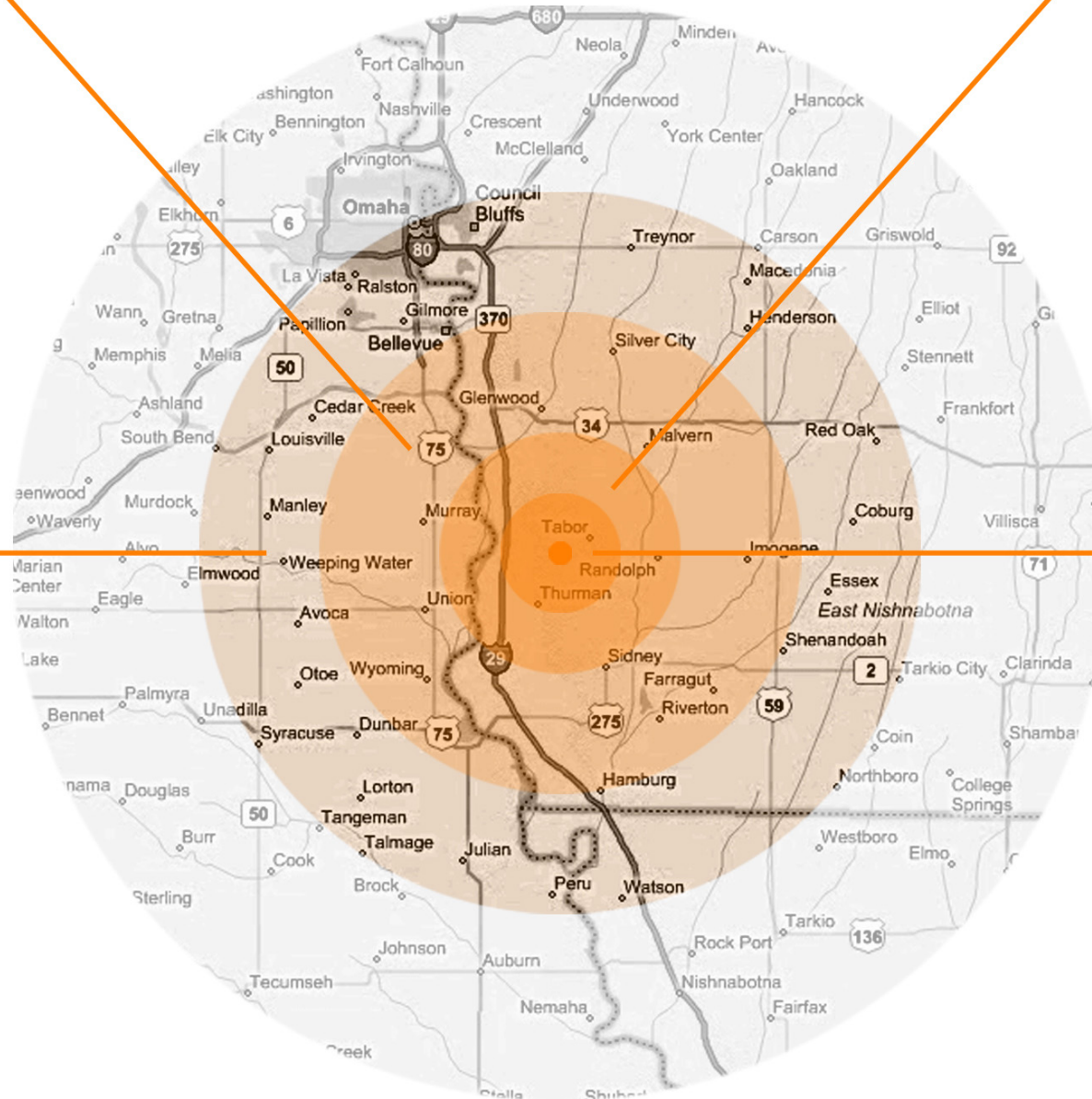

Site Analysis

(site area)



Site Analysis

(relief plan)

1280
1270
1260
1250
1240
1230
1220
1210
1200
1190
1180
1170
1160
1150
1140
1130
1120
1110
1100
1090
1080
1070
1060
1050
1040
1030
1020
1010
1000
990
980
970

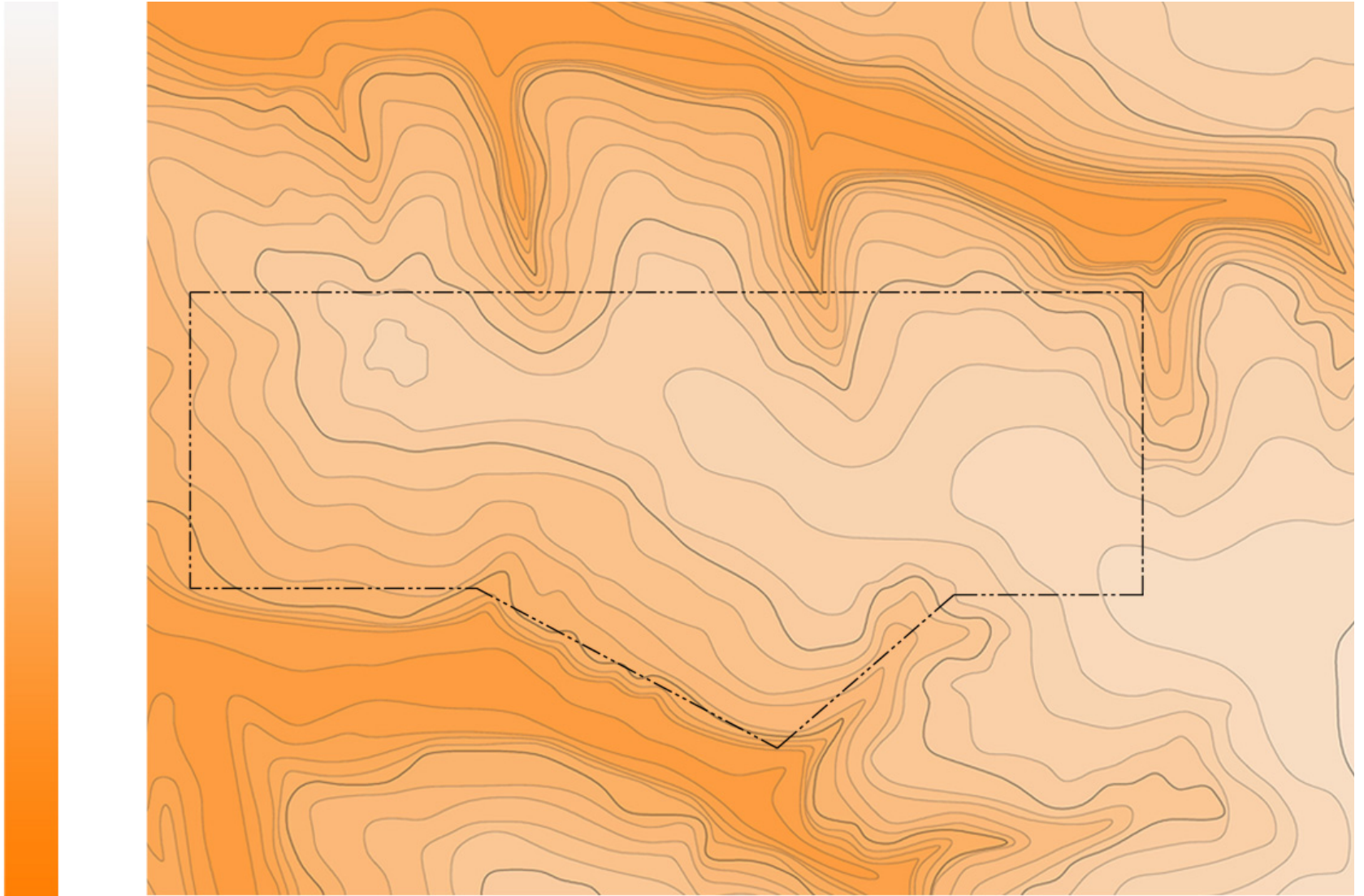

Site Analysis

(existing site plan)

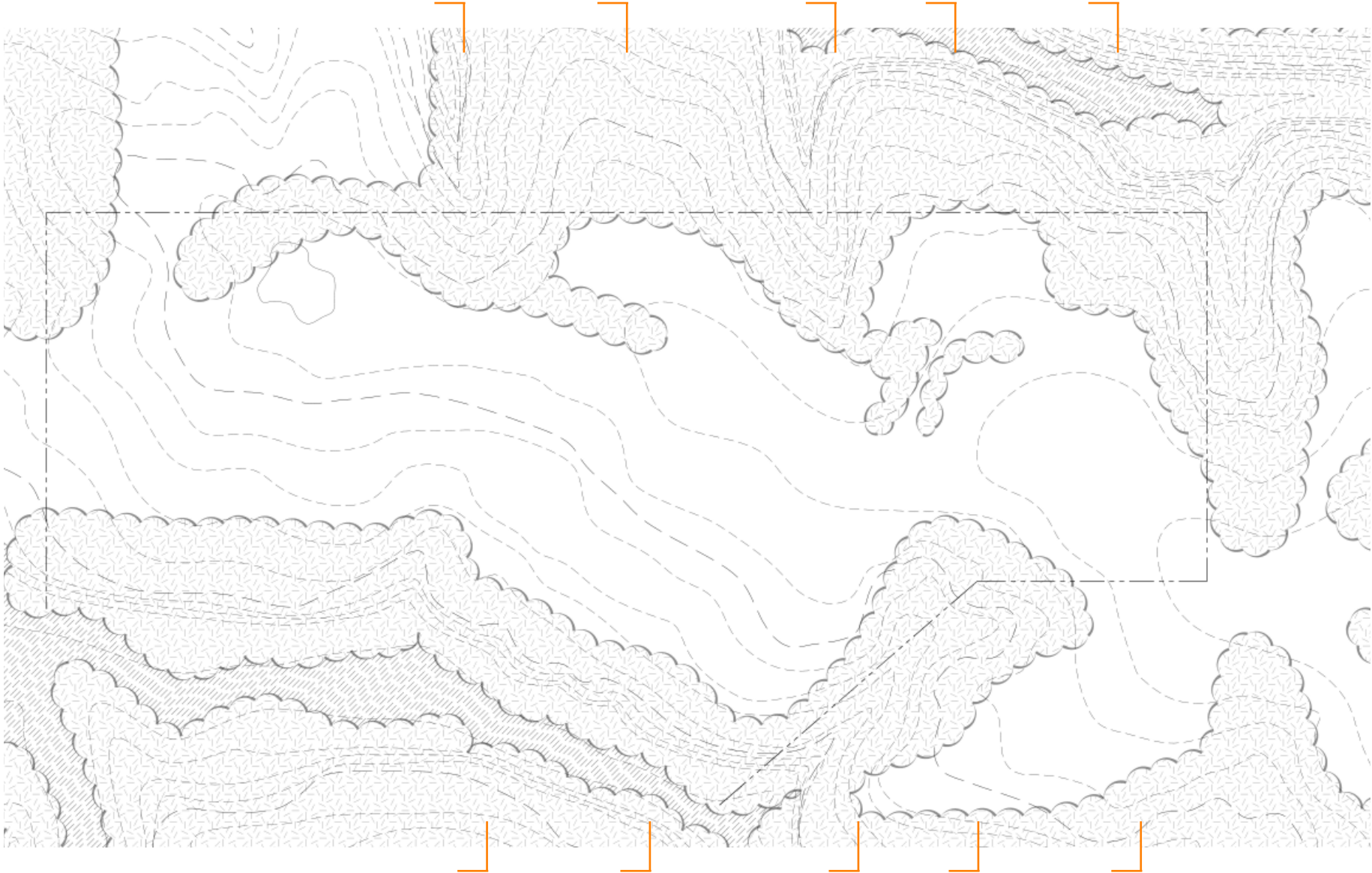

Site Analysis

(existing site sections)



Site Analysis

(grid dependence)

Complete dependence on the grid can lead to a serious, even life threatening situation under aggravated climatic conditions. These conditions can range from extreme temperatures, excessive wind and floods. Knowing how to reduce or eliminate this dependence can greatly enhance the quality of life and even chances of survival when connection to the grid is lost.

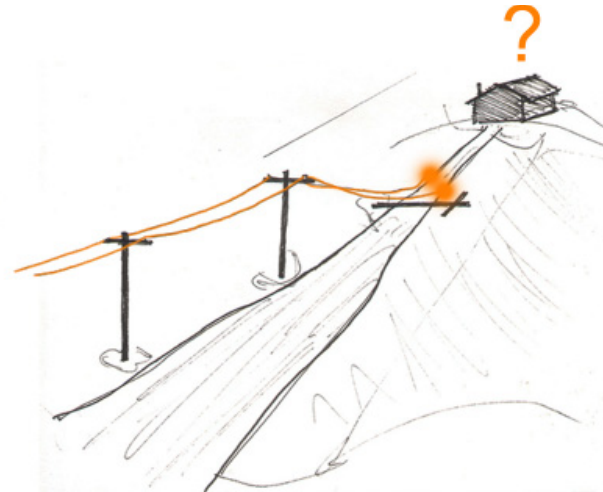

Precedent Studies

The following pages include a variety of precedent studies. After analyzing the site, several architects were chosen whose projects could provide valuable insight into what is possible and appropriate for the challenge at hand. They were chosen because of the conditions they were designed for, but also the archi-eco friendly practices they employ.

First, an author by the name of James Howard Kunstler whose writings talk about the end of the suburban model as we know it and the retreat back to a more rural, agrarian society.

Then a couple of rural clusters done in two different areas of the world. La Luz by Antoine Predock, located in the desert southwest of the United States, and the Fredensborg Houses by Jorn Utzon, located in Denmark. Both incorporate archi-eco friendly design, yet are based around a communal idea.

Third, some selected works of Glen Murcutt who does what is considered “brush architecture”. From his projects a knowledge of what true off-the-grid design should incorporate and integrate some of those techniques into the challenge at hand.

Next, the more local architecture of Frank Lloyd Wright and the Jacobs house, aka, solar hemicycle house. From this, a knowledge of how passive heating works will be obtained. The goal here is to be able to use that knowledge to create a more passive design.

Finally, the modern styles of Eduardo Souto de Moura and Le Corbusier will be examined, in an attempt to better understand the link between built environment and nature.

After analyzing the beneficial and negative aspects of the design precedents, an attempt to marry the intent and techniques of each with the site information will be done to create a series of dwelling units which will be response first and foremost to the occupant, but also the environment.



James Howard Kunstler

Greenfield Center, New York

James Howard Kunstler (born 1948) is an American author, social critic, and blogger who is perhaps best known for his book *The Geography of Nowhere*, a history of suburbia and urban development in the United States. He is prominently featured in the peak oil documentary, *The End of Suburbia*, widely circulated on the internet. In his most recent book, *The Long Emergency* (2005), he argues that declining oil production will result in the end of industrialized society and force Americans to live in localized, agrarian communities.

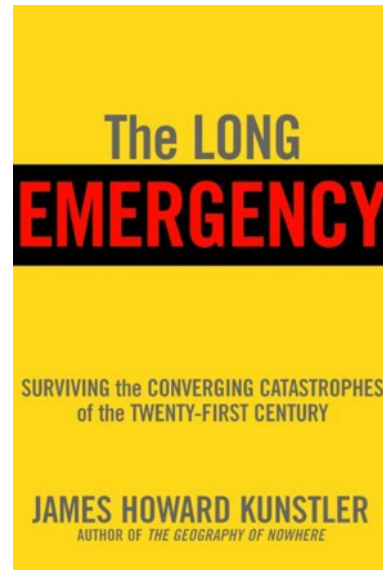
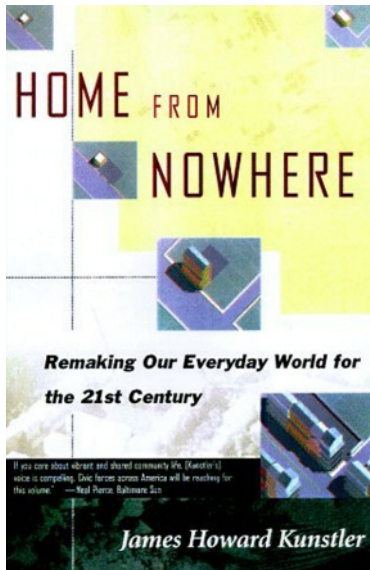



James Howard Kunstler

Greenfield Center, New York

“I kind of like this old building, too. I’m told it was a school house early in the last century. Now, it contains rental apartments. The arched windows in the gable are nicely proportioned and expressive.”

“It takes a village to make a house. These days, the civic impoverishment of suburbia is so intense that house-buyers feel the need to stick multiple unnecessary roof articulations on the facade to sustain the illusion that they are coming “home” to a village. Each house in the subdivision has to symbolically repeat this idea of being a village unto itself. The added expense in gutters and flashings can easily mount up above \$20,000 in a house like this one outside Kansas City. ”



James Howard Kunstler

(analysis)

Although Kunstler does bring up some good points, the entire argument he provides is not considered totally valid on all fronts in regards to the future of suburbia.

For instance Kunstler talks about how suburbia will come to an end, and how society will retreat back to a more decentralized, agrarian society. This may or may not be the case, however he fails to look at the issue more critically in an architectural manner. He does not go on to theorize what the quality of life may be like in the future for those living in these rural communities.

That being said, at present day people spend 90% of their time indoors. The quality of that space should be of utmost importance. Kunstler states that purely aesthetic features such as front porches will be obsolete as they have become non-functional and more of a historical notion rather than an important feature of a dwelling.

Knowing that society will change, it is important to understand what direction those changes could lead. As suburbia ends, the quality of life as well as the efficiency of the dwelling should increase greatly.

La Luz

Albuquerque, NM 1967-74

La Luz, which means “the light” was designed by architect and gold medal winner Antoine Predock in 1967. Located above the west bank of the Rio Grande river, this development is a good example of how architecture can coexist in the natural world.

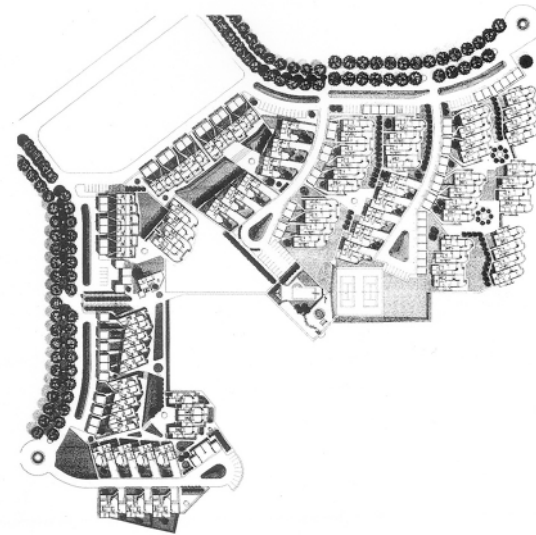

La Luz

Albuquerque, NM 1967-74

Predock gave close attention to the surroundings and natural features of the site. The houses follow the natural contour of the hill, while maintaining proper solar orientation. Concrete and glass walls take advantage of the sun's warmth in winter while patios and architectural shading devices block direct solar gain in the summer. The patios offer shelter from the winter winds, yet act as receptors for trapping solar radiation.

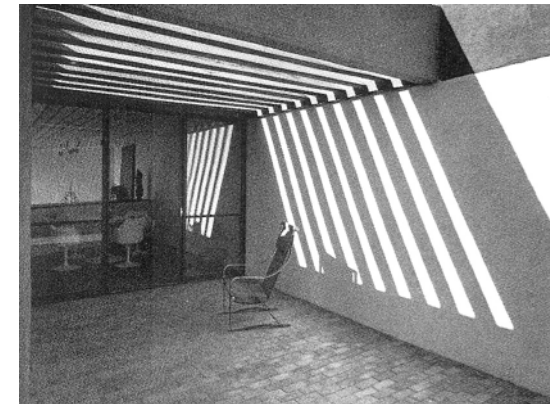

La Luz

Albuquerque, NM 1967-74

The close-knit nature of the development created a unique atmosphere. The townhouses create intimate private realms, but at the same time conserve open areas for common views and use. This concept created an indoor-outdoor life within each unit.

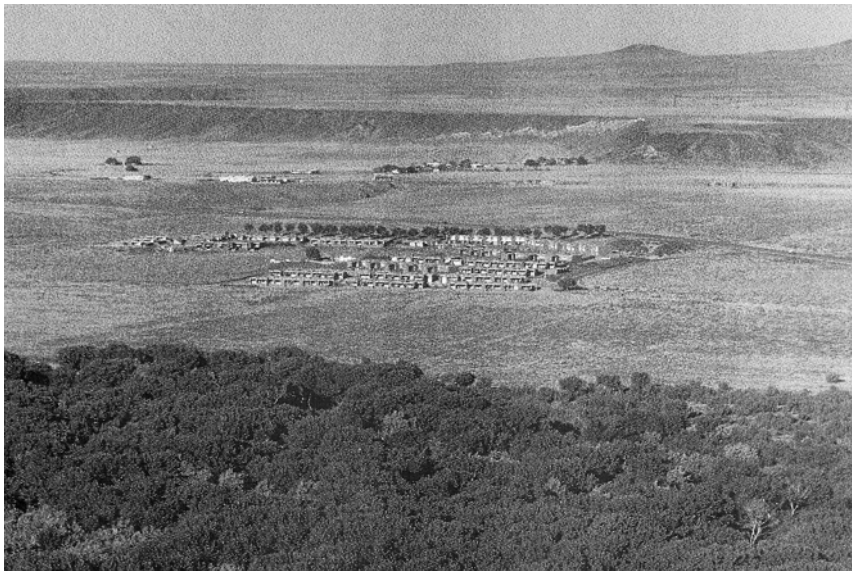

La Luz

Albuquerque, NM 1967-74

The development showed that it was possible for an urban environment to coexist within a natural, rural setting. Predock himself was quoted as saying, "urban environments and open natural areas can and should coexist."

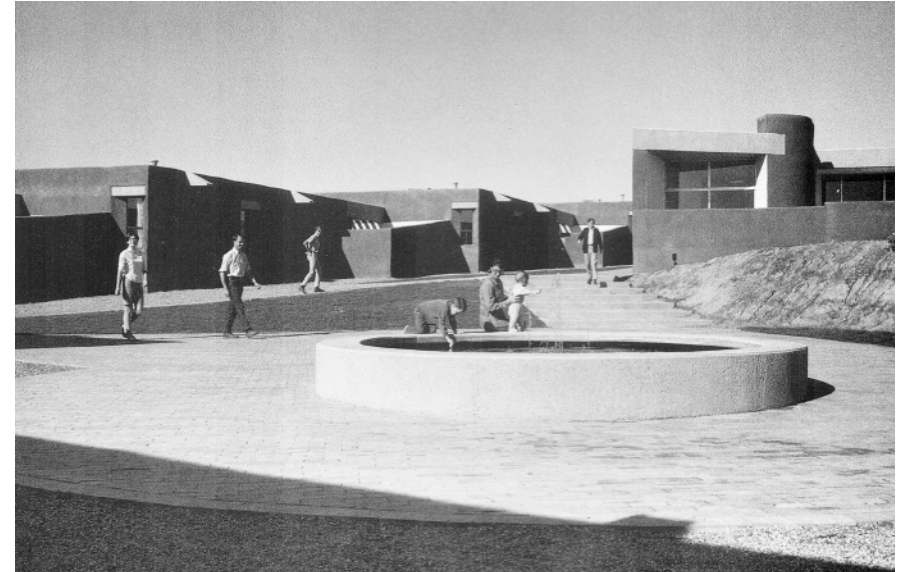

La Luz

Albuquerque, NM 1967-74

The architecture does well by responding to the environment in many ways, even at night Predock's creation lends itself well to the surroundings.



La Luz

(analysis)

The community aspect of La Luz is perhaps what makes it so successful. Predock took a lot of design cues from the natural surroundings, but the natural environment itself was not solely responsible for the success of development.

Predock actually convinced many of his friends to move into the community to get it populated. Initially the idea of living in a rural development in the middle of the desert did not excite many people. However, once populated, the inhabitants came to love their new home and La Luz has flourished ever since.

Knowing the struggles Predock had to face, it could be said that only through sheer idealism and a few favors did the community actually take off. A rural community in southwest, Iowa would face some of the same struggles, however learning from the communal aspect of La Luz, those ideals could be incorporated into the project in hopes of success.

Fredensborg Houses

Fredensborg, Denmark 1959-62

The Fredensborg houses were for Danish foreign service retirees. Jorn Utzon assisted finding the site. There were 47 courtyard and 30 terraced houses grouped around a square in staggered blocks of three, with all entrances from the square. Each house had a view of, and direct access to, a green slope. Utzon integrated communal meeting and dining functions with private houses in a way that was part of the Danish zeitgeist. Guest rooms were also included, not as part of the houses but as a separate clustered element.

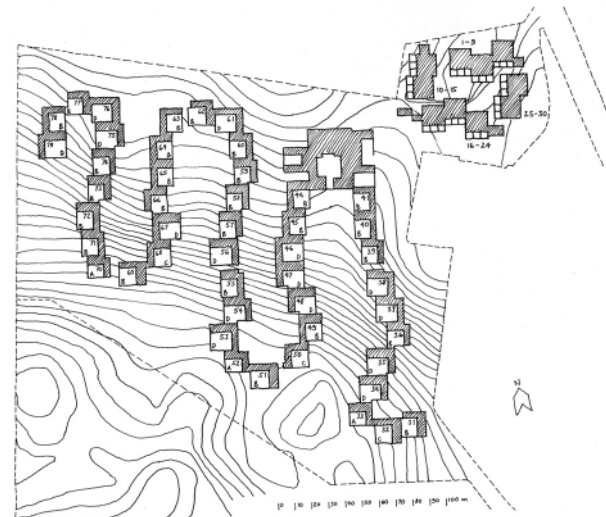

Fredensborg Houses

Fredensborg, Denmark 1959-62

The houses in Fredensborg are also called, “The Terraces”, because the buildings are terraced to fit in with the sloping terrain. This meant that some of the courtyards are several meters above the level of the green slope. The projecting walls rise like those of a medieval city. Each house is a strong individual element, sculptural and powerful as an urban unit.

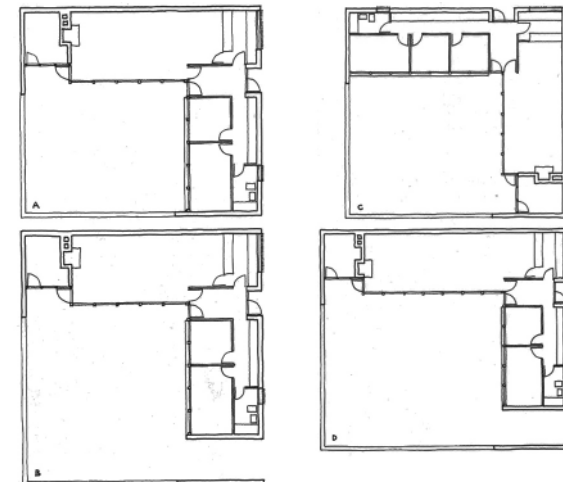

Fredensborg Houses

Fredensborg, Denmark 1959-62

The L-Shaped courtyard houses differ in size and orientation. All have a living room facing south or west. Some rooms are five bays long, while others are seven. Residents can close one or two of the window bays if they want to restrict the light coming into the space. Some houses have one bedroom and one other room, others have two other rooms. Even though Utzon designed a layout for each courtyard, residents have made their own individual contributions which makes them more appealing.

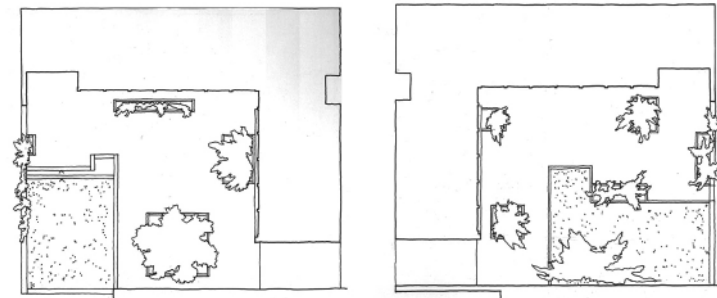

Fredensborg Houses

(analysis)

The Fredensborg cluster is similar to La Luz, with the exception that Fredensborg is a retirement community. Utzon, like Predock used the site to inform the design in terms of arrangement on the site.

By aligning the courtyard-style houses with natural contours of the site, the houses flow and are in harmony. However, this arrangement does have negative aspects in regards to excess solar gain. Some of the houses have a large amount of exposed glass which faces due west. These particular houses need excess cooling during the summer.

Knowing the downfalls of adhering strictly to a contour, the dwellings on the proposed site should not have any western exposure. Not allowing this exposure will help keep the dwellings cool during the summer.

Magney House

Bingie Bingie New South Wales

1982-84

This house is the product of several earlier ideas combined into one. Glenn Murcutt, recipient of the 2002 Pritzker Prize designed this house to respond to the tough, exposed site on which it is situated. Murcutt situated this house on the brow of the hill, rather than the top, which was the approach advocated by Frank Lloyd Wright.

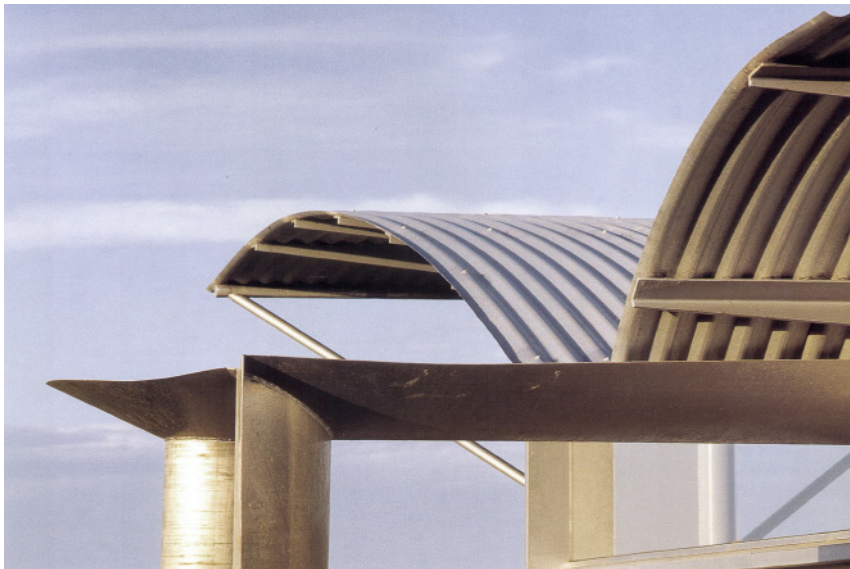

Magney House

Bingie Bingie New South Wales

1982-84

Murcutt planned for this house to take advantage of the northern view and light. The room takes its cues from the hills on which the house is built. The angle of the roof struts are set to suit the equinox sun angles. Floor to ceiling blinds control the amount of light access into the house. During the summer they can be tilted to keep out the radiation, and in the winter opened up to allow the entire cavity of the house to be naturally lit.

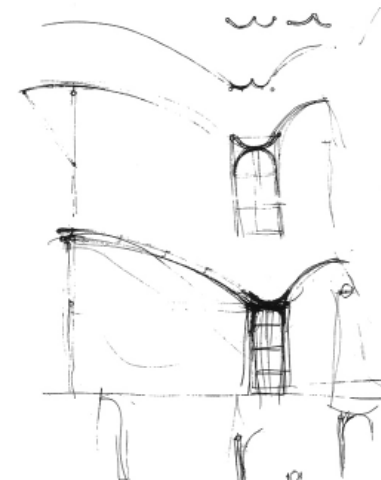

Magney House

Bingie Bingie New South Wales

1982-84

The occupants benefit from the large amount of glass on the north side. A large amount of light is allowed into the space, thus heating the grey tiles on the floor. Murcutt realized the thermal mass benefits concrete has if insulated and applied properly.

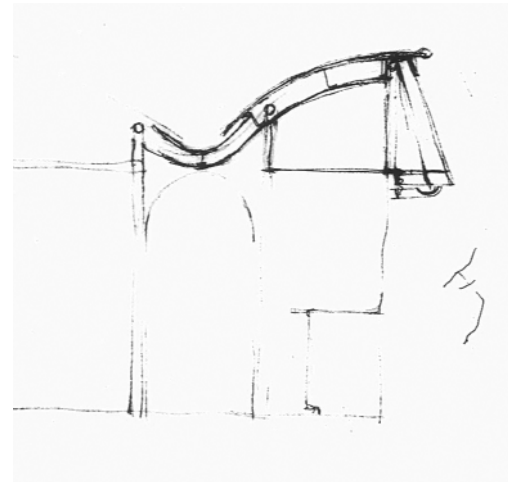

Magney House

(analysis)

Like most of Murcutt's designs, this house takes advantage of passive solar gain. This will be an important aspect that can and should be utilized in the proposed dwellings.

The materiality of the Magney House is demonstrated in a light, almost transparent manner. The transparency can be carried over into the proposed dwellings, however the insulating qualities of Murcutt's work is far less than what is required for the site in question.

Being able to provide a proper envelope that is functional, responsive, appropriate and transparent will prove to be a challenge.

Fletcher-Page House

Kangaroo Valley New South Wales
1996-98

This house is a great example of multi-role functionality and environmentally responsive design. Here Murcutt has again optimized the design for northern exposure and provided plenty of light glazing to allow natural light to flood the space. He has also incorporated operable blinds that provide shade from the sun, act a privacy screen when closed, but also add an element of aesthetic beauty.

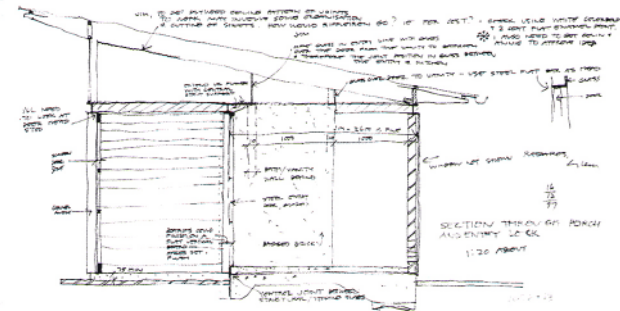

Fletcher-Page House

Kangaroo Valley New South Wales

1996-98

The angle of the roof is tilted at 11 degrees, which is the same as the site slope and provides for optimal solar shading during parts of the day with the sun is at high angles. The metal roof acts a rainwater collector but also takes on the light and colour of the surrounding elements and sky.

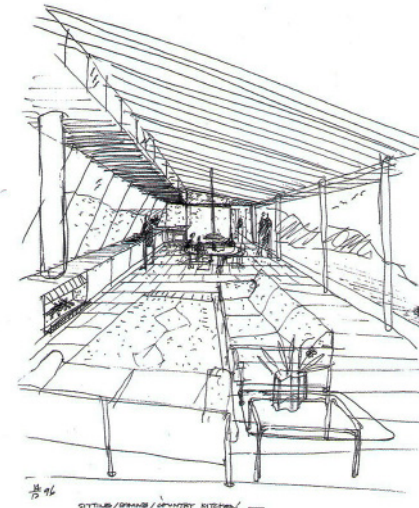
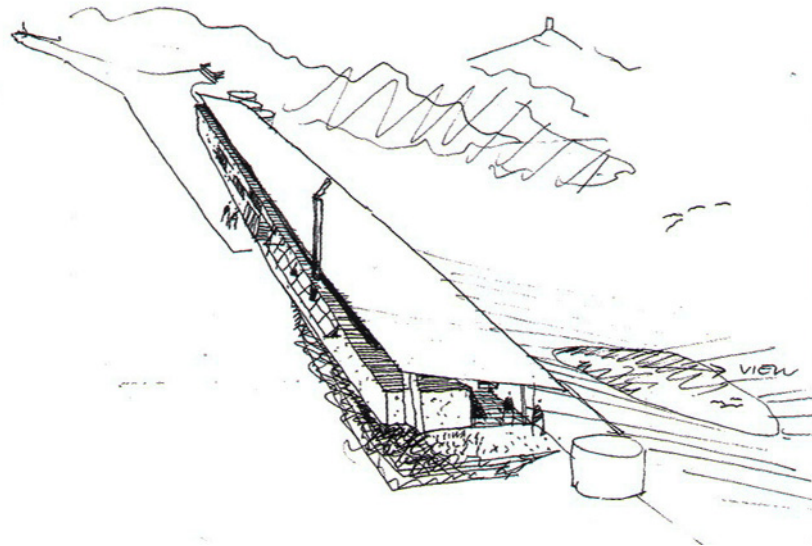

Country House

South Highlands New South Wales

1988-92

Like most of Murcutts designs, this house takes advantage of the norther exposure. The corrugated metal roof acts as a large scoop for rainwater collection. The house is situated at the base of a hill because winds at the top would whistle through the house like a flute.

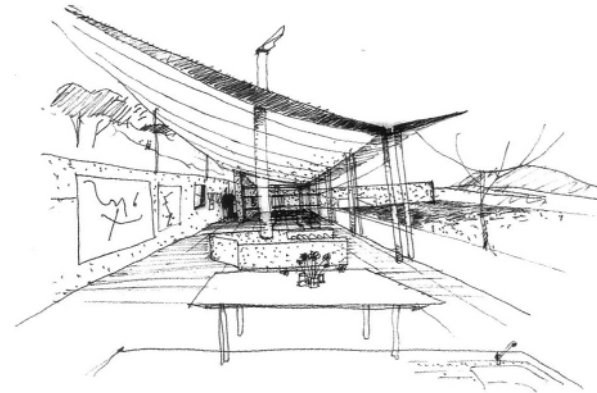

Country House

South Highlands New South Wales

1988-92

Murcutt studied the site extensively and did several sketches which illustrate the amount of thought given for proper placement. Sun, drainage, wind and aesthetic views were all taken into consideration.

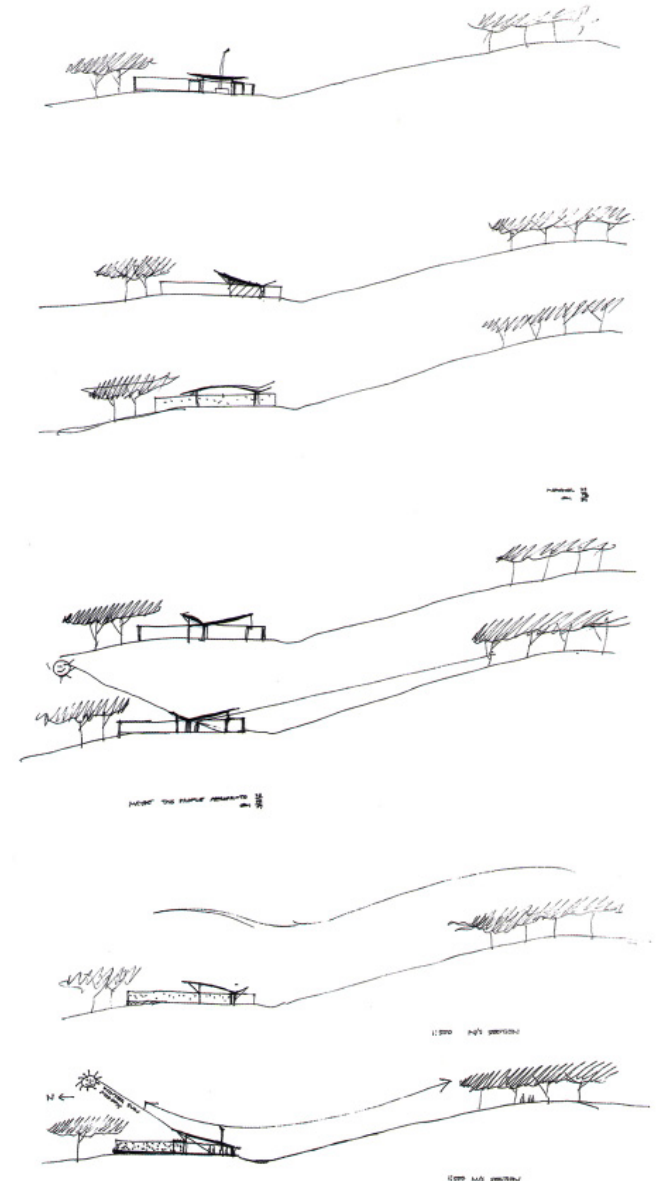
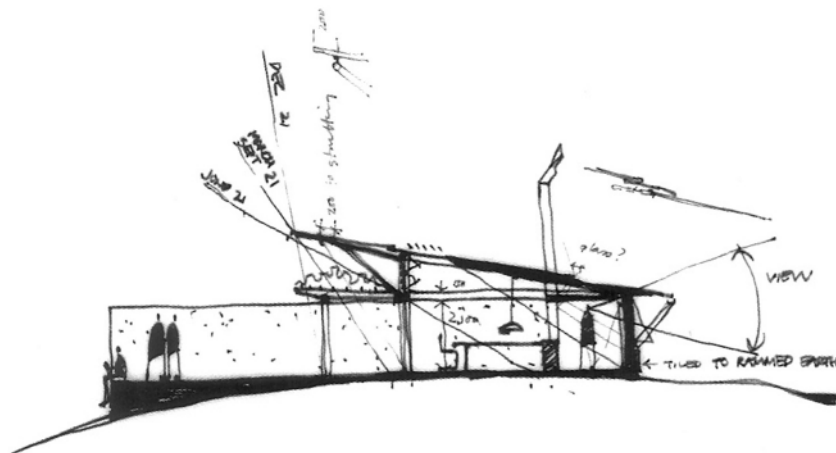
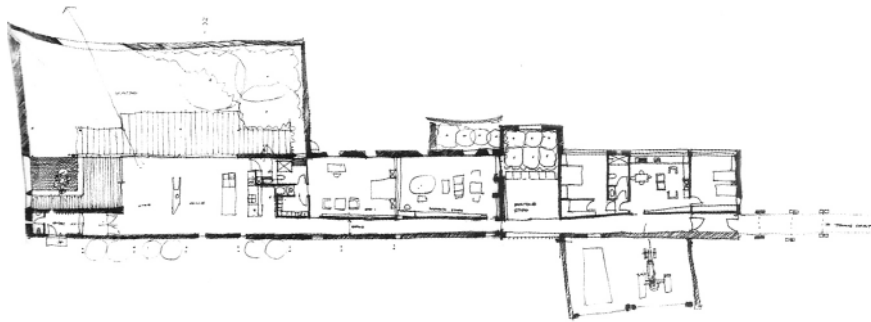

Country House

South Highlands New South Wales

1988-92

The synthesis of eco and archi friendly design is even more apparent when viewing this house from the inside. Natural lights floods all the spaces, blinds provide aesthetic appeal and functionality.



Country House

(analysis)

The Country House and Fletcher-Page House fall into the same category as the Magney House in that they are very light and transparent in appearance, and almost seem to hover above the ground.

This notion of touching the ground lightly is appropriate for the region in which Murcutt is designing, however this form of approach will not work for the site in question.

The region in which the proposed dwellings will be located is much more harsh and has greater extremes, thus requiring the dwelling to be anchored and insulated by the earth in some manner.

Jacobs House II

Middleton, Wisconsin 1943-48

The Jacobs House, also known as the “Solar Hemicycle” or “Hemicyclo” house was designed by master architect Frank Lloyd Wright. The house assumes the form of a 180 degree arcade like an arched eyebrow. The inner wall of the semicircle faces southwest towards the low angled winter sun. The outer wall and end caps are made of limestone, resembling the natural limestone strata which occurred naturally on the site. In the front of the house is sunken garden which creates an air pocket to shield it from the prevailing winter winds. The entire house is surrounded by an earth berm which helps to add thermal mass benefits.

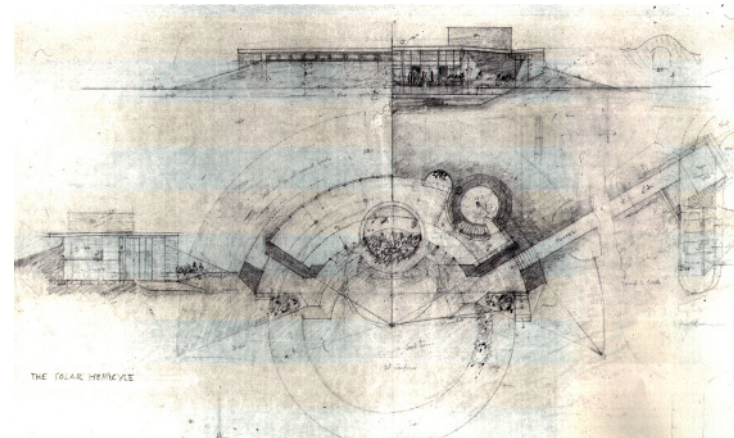

Jacobs House II

Middleton, Wisconsin 1943-48

The semicircular nature of the plan allows for maximum solar exposure during the winter months. This type of intuitive design allowed the residents to heat their homes naturally without the use of electricity or mechanical means.

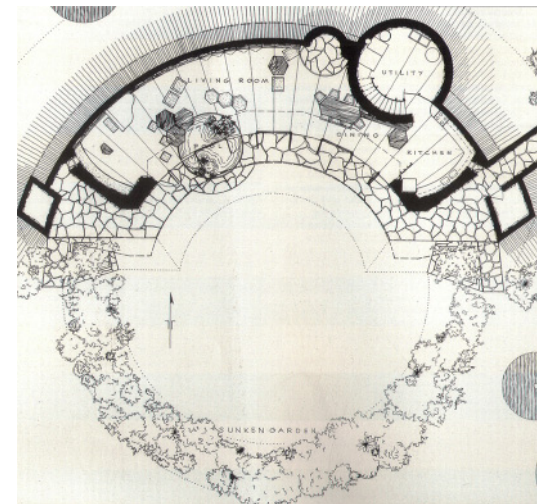
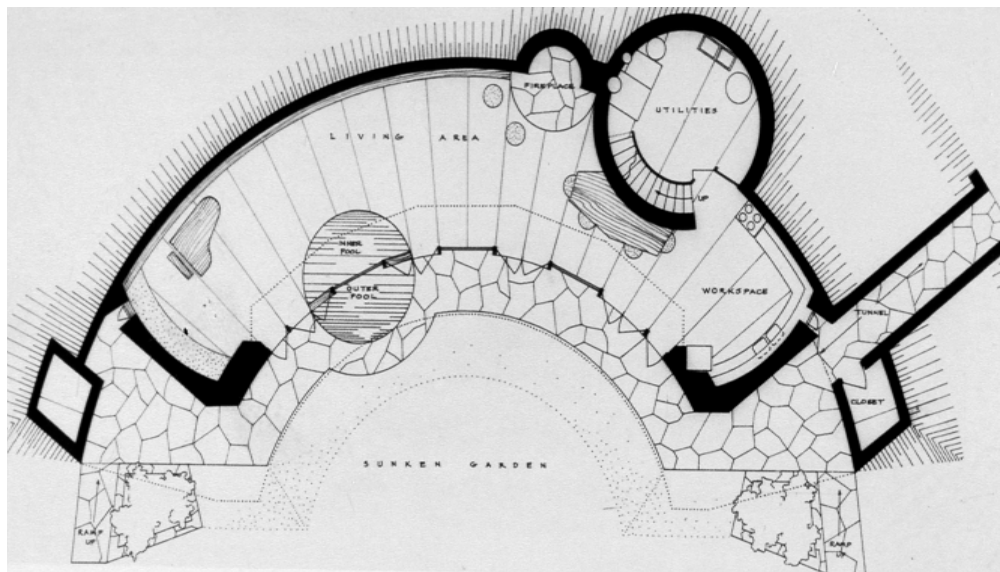
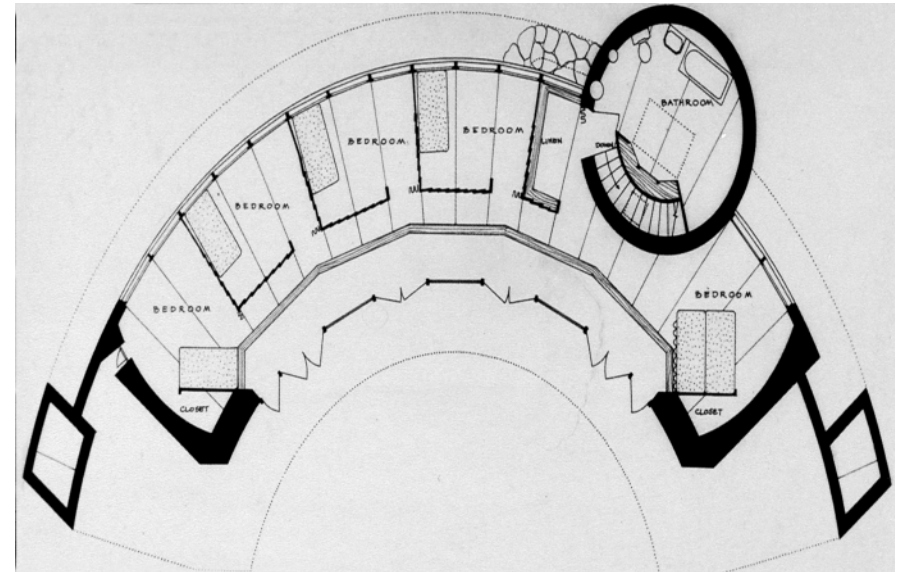

Jacobs House II

Middleton, Wisconsin 1943-48

The built up earth berm cradles the house and protects it from cold northern winds. The entry to the house from the garage is through a short tunnel which is carved out of the berm.

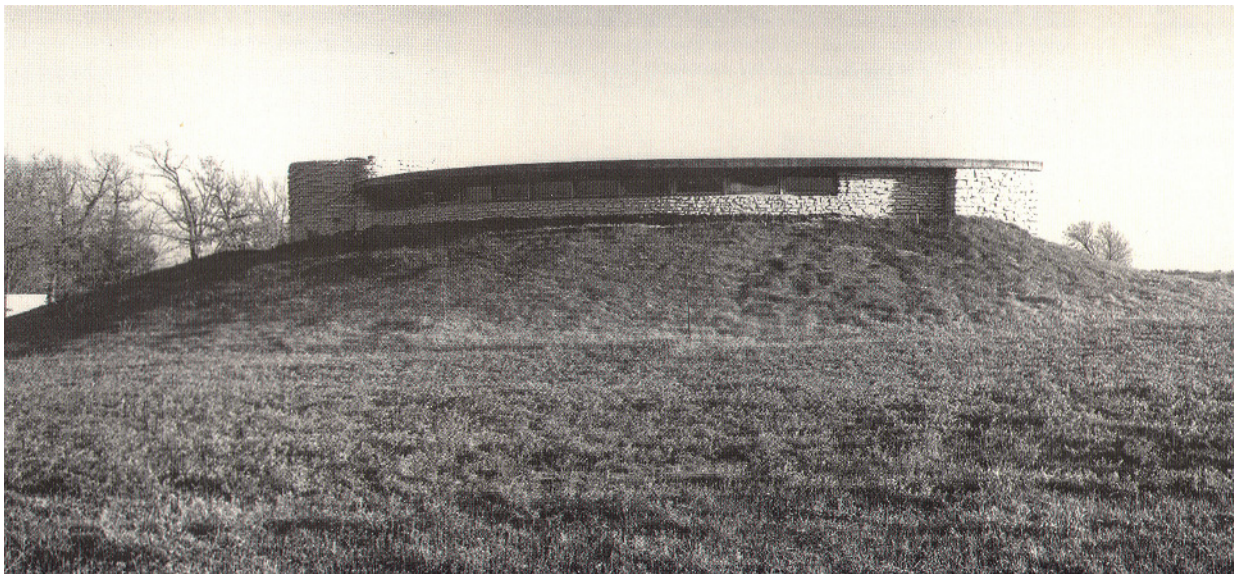

Jacobs House II

Middleton, Wisconsin 1943-48

Thirteen foot windows allow natural light to flood the space and reach to the rear wall. The rear wall is made of limestone, and stores heat during the day. At night when the sun is down, the wall releases its heat into the space at no cost and with no need for mechanical equipment.



Nevogilde House I

Oporto, Portugal 1982-85

“The discovery of a pattern seems to be inherent in the human activity of making. What are the criteria that make certain models, as opposed to others, worthy of being copied? In a country such as Portugal, which is profoundly aware of its roots and traditions, the act of dwelling, permeated by a strong sense of intimacy and use make the range of options available to us clear, if not definitive.

The house becomes the disguise for spaces that vary according to function and use.”

-- Jose Paulo dos Santos

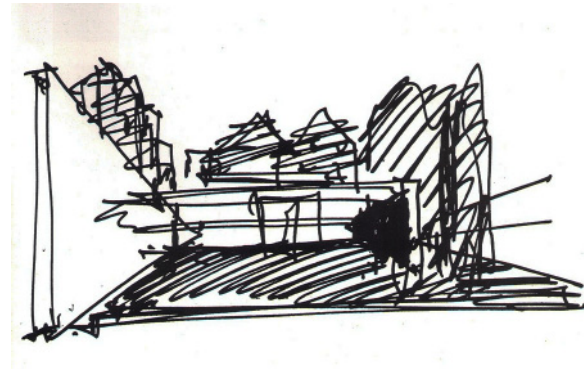

Nevogilde House I

Oporto, Portugal 1982-85

In this rectangular plot, the boundaries were defined by party walls. A longitudinal wall crosses the building, separating the annex and service areas from the house itself. The structure is enclosed on the sides and open at the ends, with bedrooms facing east and the living room opening onto a garden facing west. A central courtyard organizes the circulation. DeMoura recessed the windows to ensure protection from the summer sun, yet used floor to ceiling glass to maximize natural lighting.



Alcanena House

Torres Novas, Portugal 1987-92

Located within the confines of an existing vineyard, this house is perched atop a gently rising hill. The solitary character of this house does not interrupt the flow and continuity of the surrounding countryside. Here again locally quarried stone is used to give the impression of solidity. The large walls slice through the earth like fingers in freshly plowed soil, creating a direct connection between the site and dwelling.

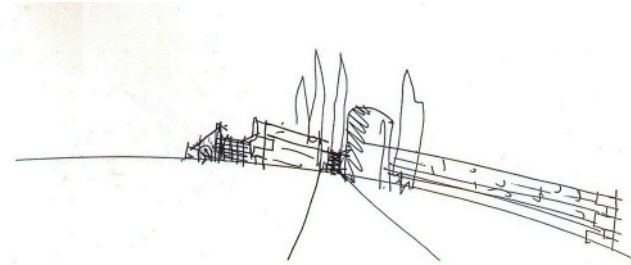

Baiao House

Baiao, Portugal 1990-93

This house is cradled within the remains of an existing ruin. DeMoura's deep respect for the landscape lead him to design a dwelling that gave little indication to its existence within the hill. By using materials located on site, he created a dwelling that is well disguised, but if discovered will give the impression it has belonged there all along. In addition to the sensitive landscape, DeMoura clearly shows his attention to solar orientation through the use floor to ceiling glass.

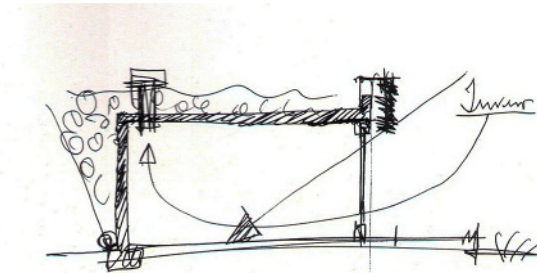
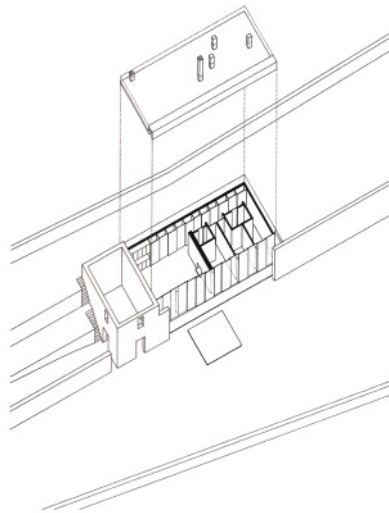

Monol House

Celle-St. Cloud, France 1935

This weekend house by Le Corbusier combines the design of the Sarabhai House and the Maison Monol into one. The intention behind this house was to provide a “feminine” form of architecture for its inhabitants. Corbusier form a juxtaposition between the outside and inside by use of form and material. This house allows the inhabitant to experience the outdoor while being able to retreat within the confines of its walls. In a way, it magnifies the experience and makes the inhabitant more aware of the outdoors.

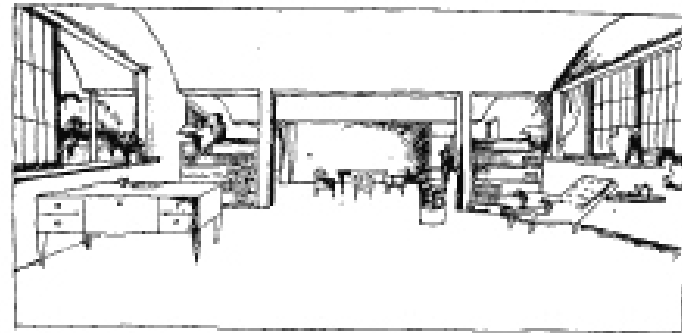
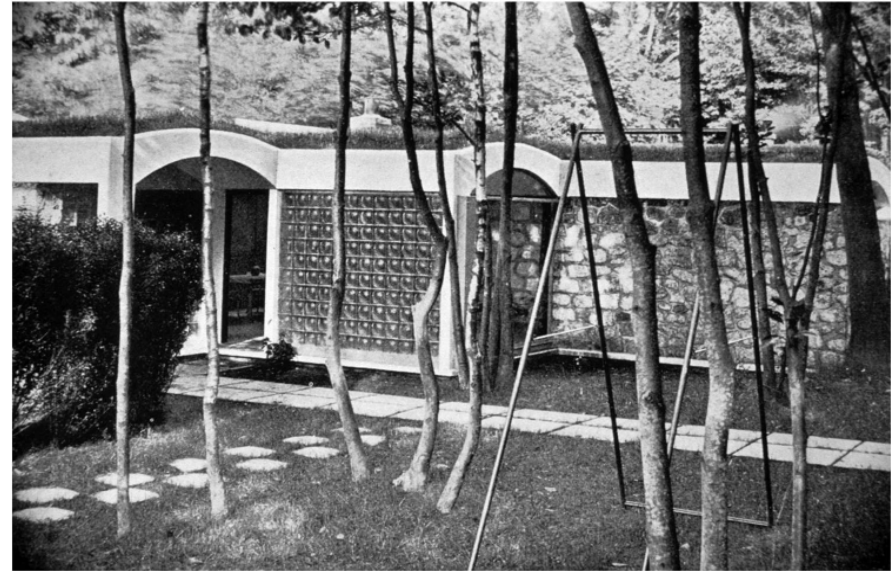

Maison Domino

ca. 1920

Although a true “Domino House” was never constructed, the principles of the form can be seen in various dwelling units. With the Dom-i-no concept, Corbusier was experimenting with a “masculine” form of architecture, which was contrary to the “Monol House”. These concepts followed his five points of architecture and were intended to create a form which dominated the landscape.

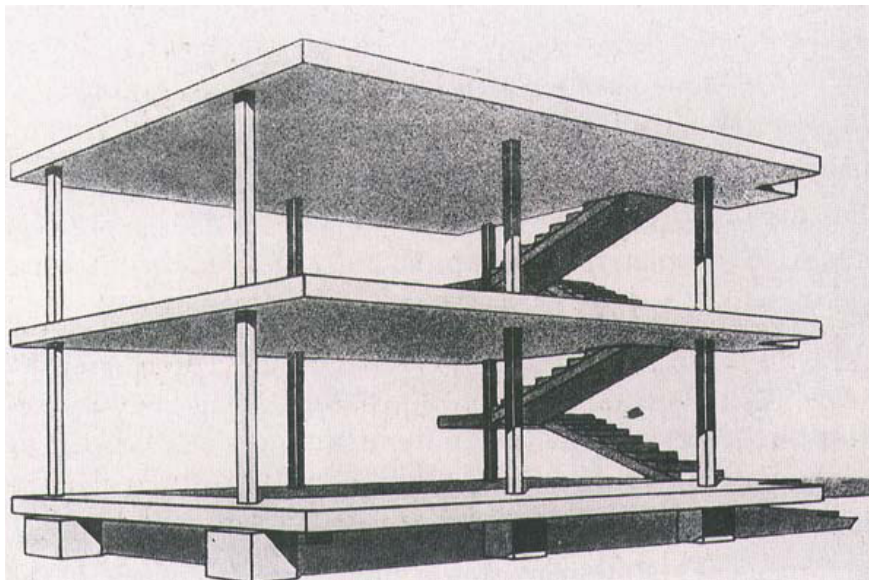

Process

The process section of the project is where the bulk of the work is located. This section includes fundamental design sketches, diagrams, prototype models and schematic design. A great deal of time was spent designing, then analyzing those designs. The design process is challenging on many levels in that not only should the dwelling in question be aesthetically appealing, but it also should function properly.



One has to be careful to ensure the final product is something which incorporates nature rather than simply trying to imitate it. The end result should be a dwelling that is truly archi and eco friendly.

The diagram on this page shows three scenarios that are often the case in architectural design.

In the first instance the design intentions are focused mainly on architectural aesthetics or function, but very little consideration is given to the affects of the dwelling on the occupant or environment.

The second instance is becoming increasingly more common in that little consideration is given to aesthetics or function and the dwelling simply becomes a highly efficient structure that nobody wants to live in.

The final scenario is the balance between architecture and environment. Good design is coupled with intuition and practicality resulting in a beautiful creation that everyone can enjoy and benefit from. By analyzing the case studies and precedent studies, the hope is to create something which is the best of both worlds.

The diagram on the opposite page illustrates the hope that if one person in a neighborhood lives in an archi-eco friendly dwelling, their intentions will carry on to their place of work. Over time others will discover the benefits of good, intuitive, responsible design and the process will continue to grow until that sort of design is simply the way it is, rather than how it should be.

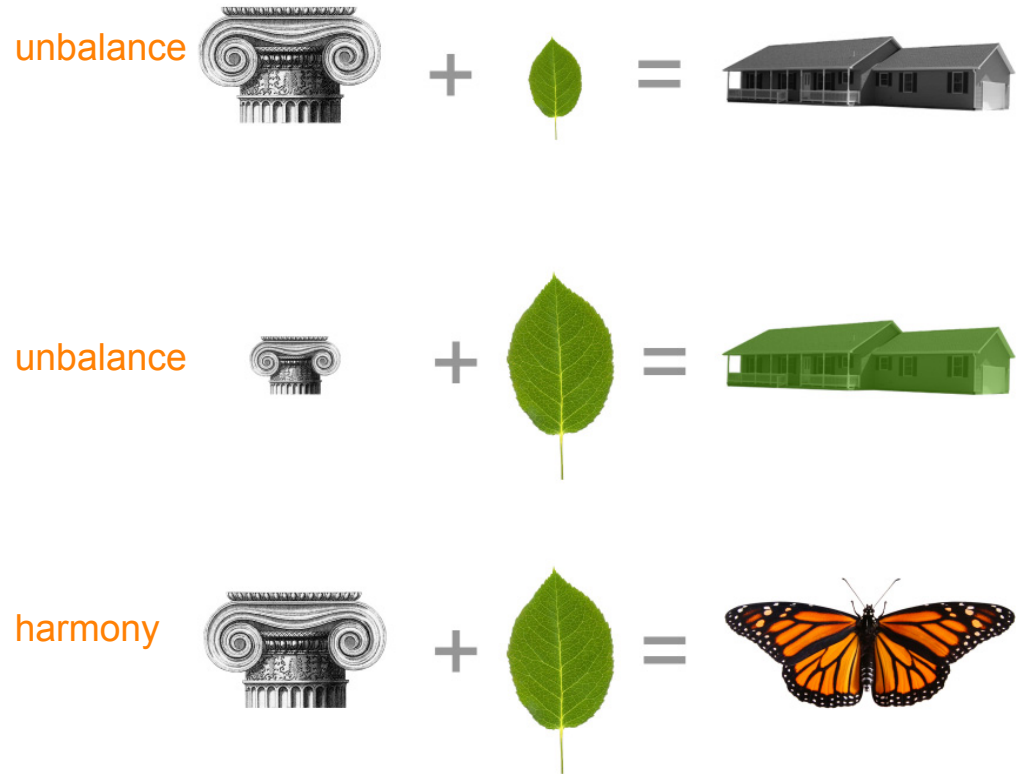

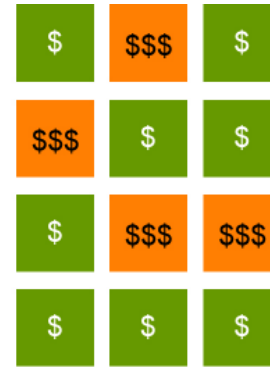

Housing

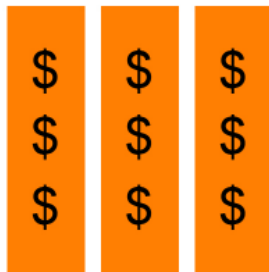
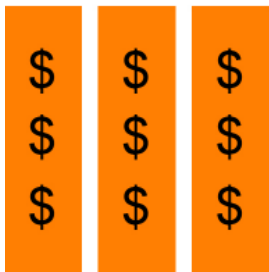

Commercial

Solutions

(design)

Advancements in technology aid us in our efforts, however these technologies are often applied ad-hoc. Careful attention to design must be given to make a truly successful dwelling. The design should not only be aesthetically appealing and poetic, but ecologically responsible as well. A balance must be struck between the ecological and technological aspects of architecture. The site characteristics should inform the design.

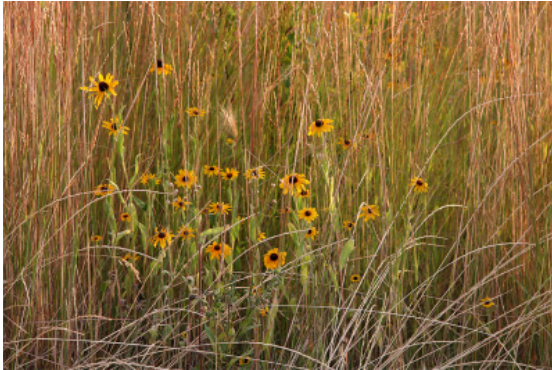

Solutions

(passive)

Passive design features such as solar space and water heating help reduce the need for mechanical equipment and lower the costs associated with traditional midwest space heating. Rain water collection or retention can reduce the amount of potable water needed for toilet flushing and/or irrigation, and when coupled with a green roof the water is naturally filtered. The green roof also reduces heat island effects and helps to keep the house cool in the summer.

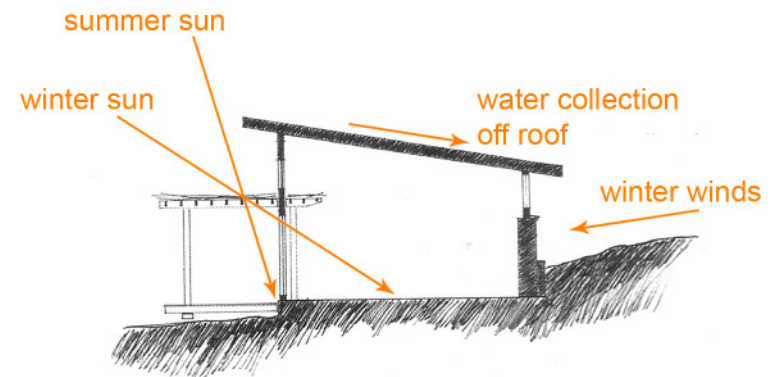

Solutions

(active)

Various technologies are available to help reduce or eliminate our dependency on the grid. These technologies include solar, wind, geothermal, low impact hydro and bio fuel. Each of these technologies alone is a step in the right direction, but when coupled to other forms of ecologically responsible power generation, the result can be overwhelming positive.

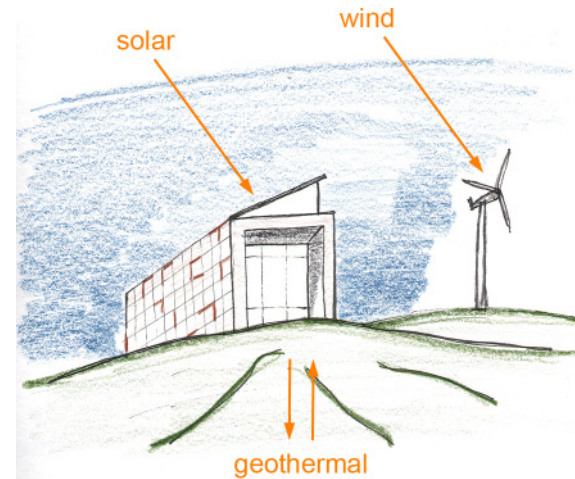

Solutions (material)

In addition to responsible, eco-friendly design and technology, materials play a crucial role in how the dwelling looks and performs. The materials must be suited to the role they will play. Some materials such as concrete and wood can have dual roles as aesthetic and structural elements. It is important that the material palette be kept simple and efficient, yet be able to aid significantly to the poetic language of the project.



native vegetation



corrugated



stone

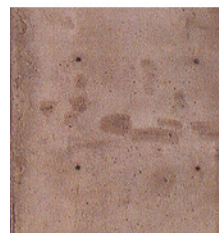

concrete



earth

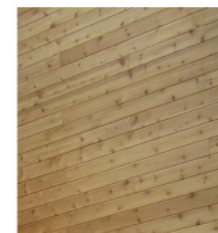

wood



steel

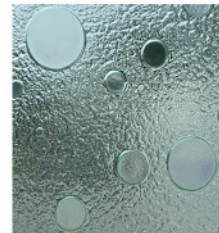

glass



brick



grasses

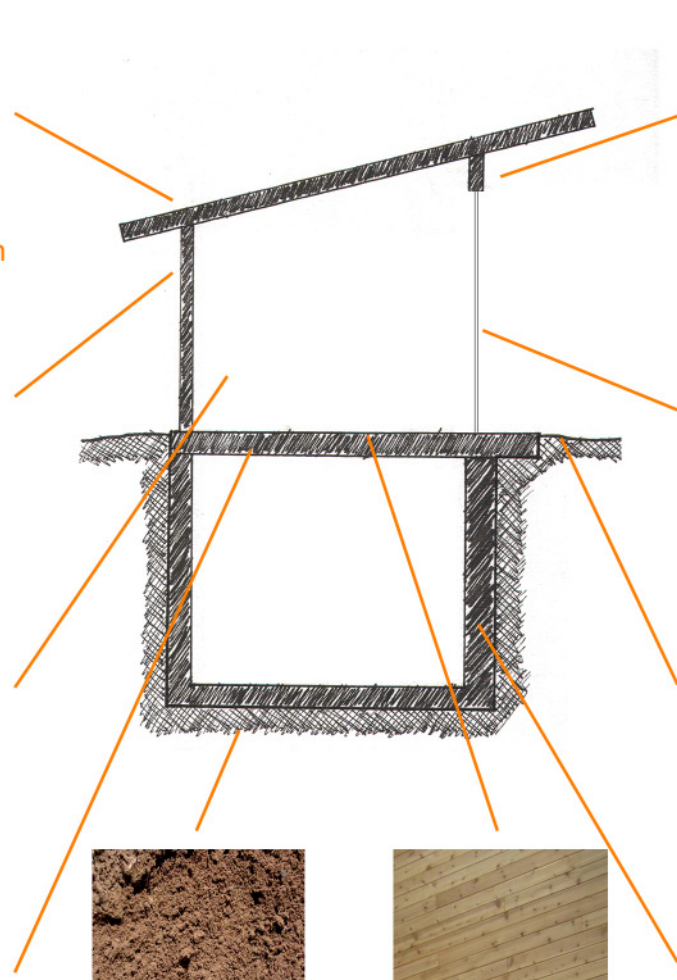

Concept Sketches

Various technologies are available to help reduce or eliminate our dependency on the grid. These technologies include solar, wind, geothermal, low impact hydro and bio fuel. Each of these technologies alone is a step in the right direction, but when coupled to other forms of ecologically responsible power generation, the result can be overwhelming positive.

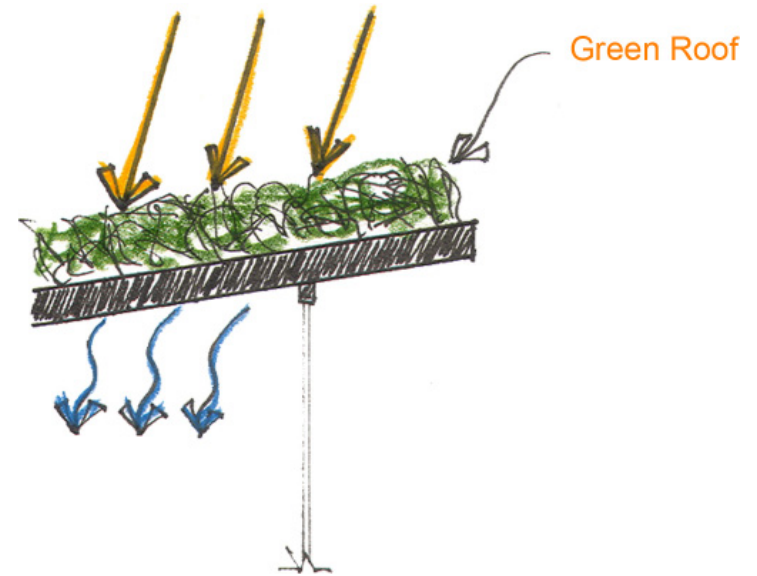

Concept Sketches

Lighting a dwelling artificially can add excess amounts of heat to a space, thus requiring additional cooling and therefore accruing additional cost. The use of floor to ceiling glass, light shelves and selective planting can not only enhance the quality of the space by providing or allowing natural light into the space, but also by keeping costs at a minimum.

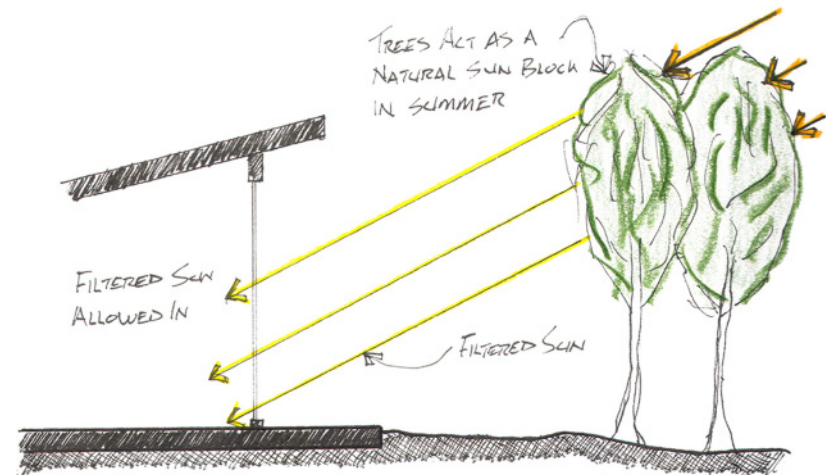

Natural Shading

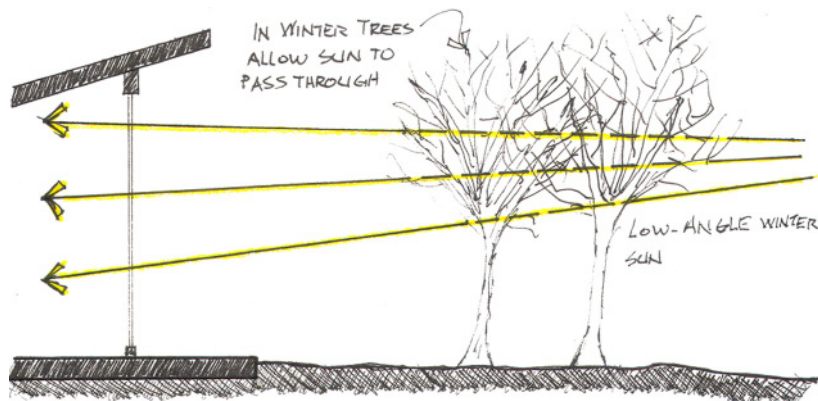

Strategic Planting

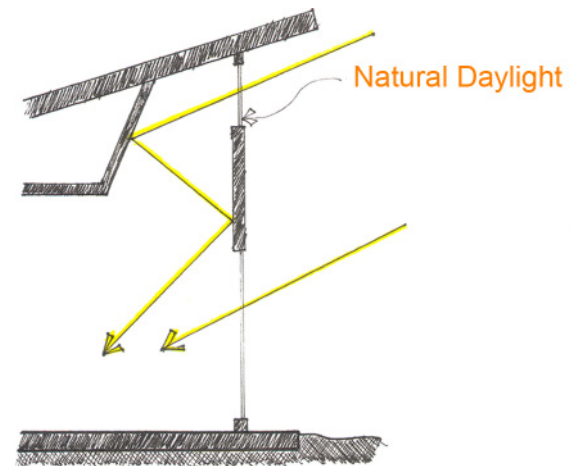

Concept Sketches

Passive solar heating is beneficial for most of the year, however there are times when direct solar gain can be harmful to the performance of a dwelling and make its occupants uncomfortable. To alleviate the negative impacts of solar gain, natural or structural shading should be employed.

If employing natural shading such as trees, it should be known that deciduous trees are best suited for this role because of their yearly cycle. If structural shading is used, it is best to have it as part of the overall design. In either case, the shading devices should block out high-angle summer sun, and allow low-angle winter sun.

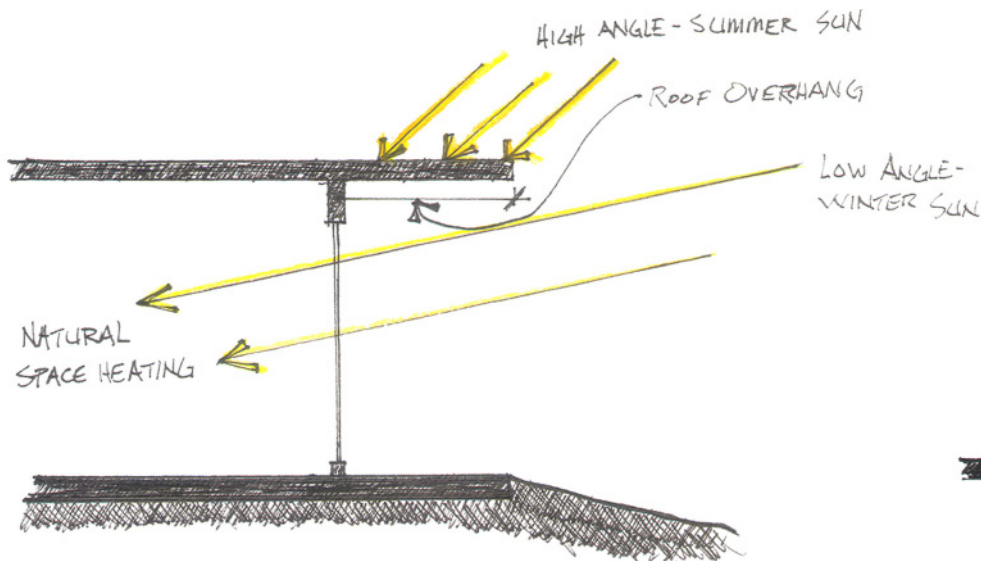
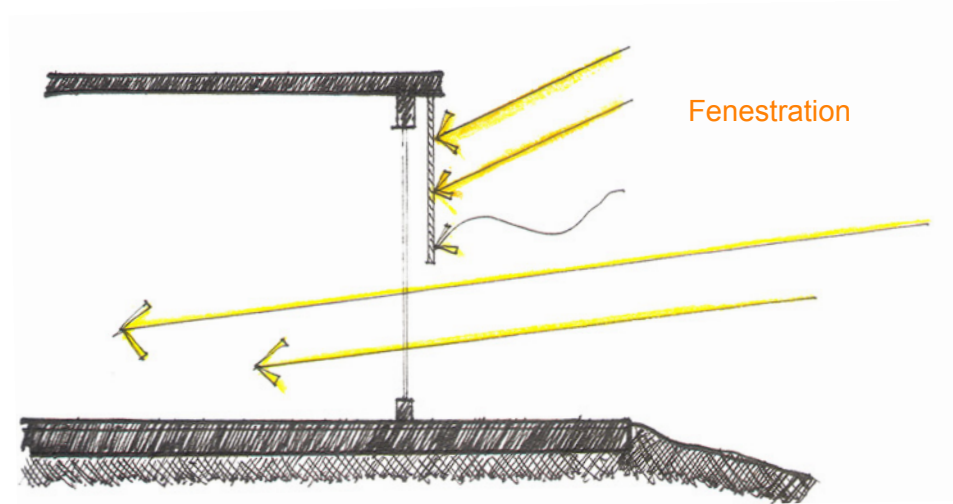

Passive Heating

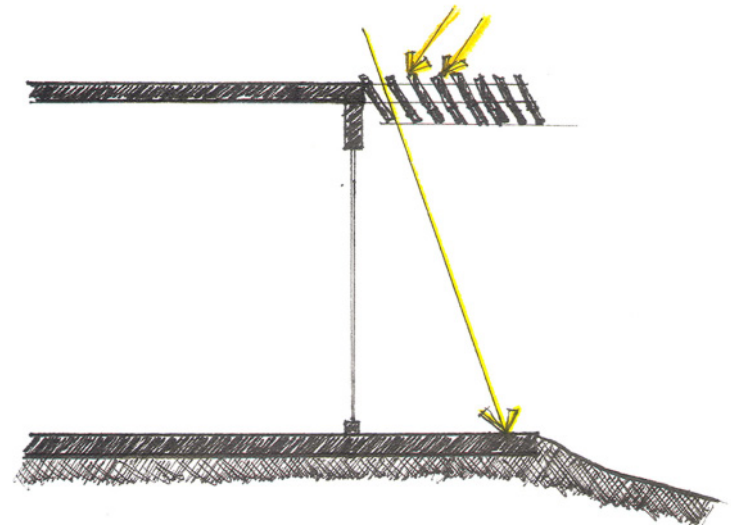

Structural Shading

Concept Sketches

Conversely to passive heating, passive cooling is equally important. Passive cooling can be achieved in a variety of ways, the easiest of which is done by simply allowing cross ventilation through the space when appropriate.

Another way to cool a space is to use thermal mass. This is a relatively simple principle in that larger, more massive materials such as concrete have what is known as a "specific heat". The sheer mass of these elements allow them to remain cooler, longer, thus absorbing excess unwanted heat from a space.

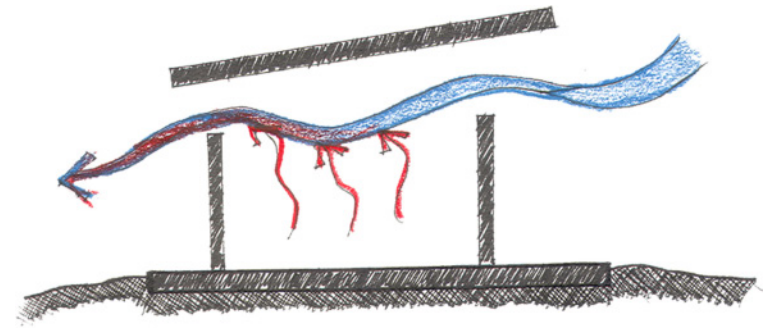

Natural Ventilation

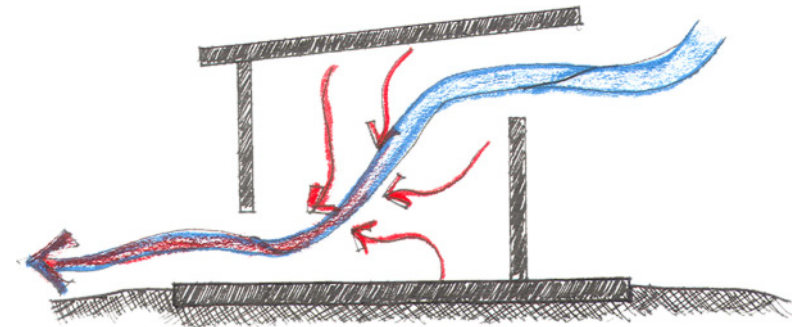
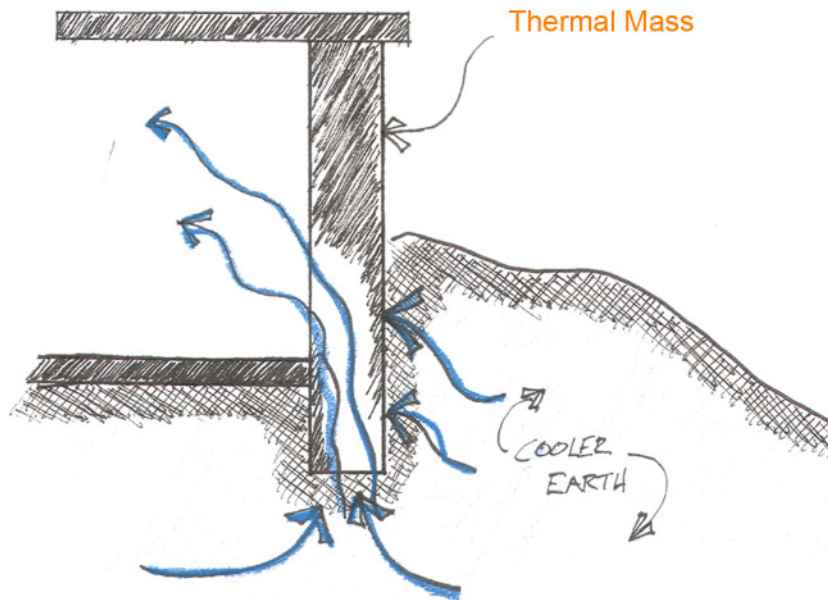

Natural Ventilation

Concept Sketches

Perhaps the most important of the passive technologies is that of solar orientation. For a dwelling to be even remotely passive, it must be oriented properly.

The sketches below illustrate sun azimuths and sun angles. The sketch to the right shows how facing due south in the northern hemisphere yields the maximum solar benefit. Deviating from due south affects how much direct solar radiation a structure receives. To receive the maximum benefit from the sun, a structure in the northern hemisphere should face due south, or not deviate east to west more than 15 degrees in either direction.

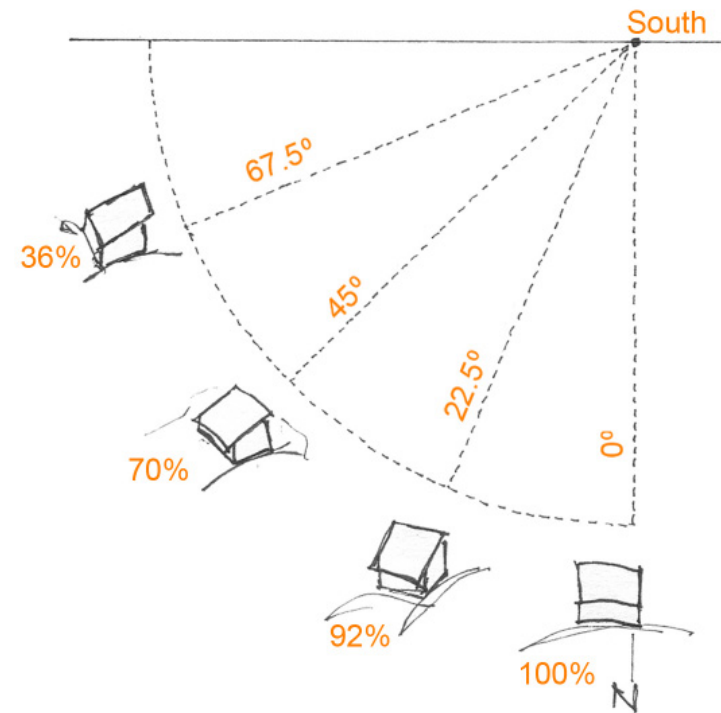
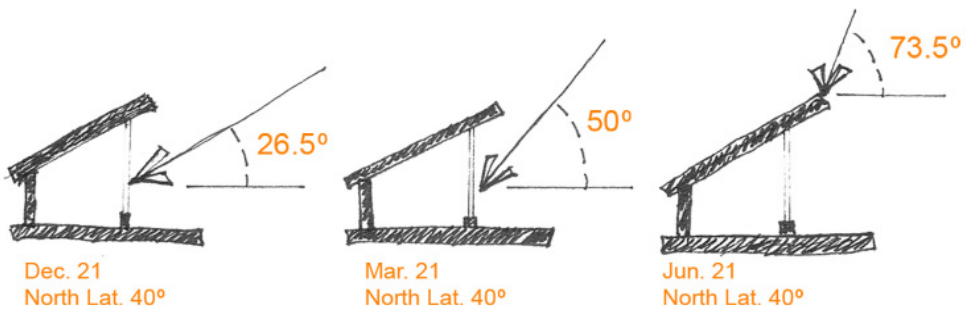
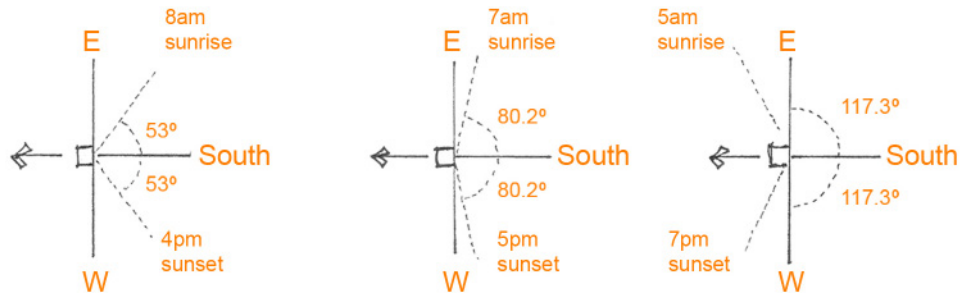

Sun Angles @ Noon

(21st day of each month)

It is important to understand the affects of the sun; not only when the sun is at its highest point in the sky, but also at its lowest. Sun angles were calculated for the latitude of the site.

Sun azimuths (opposite page) are also important to understand. Whereas sun angles give information about the suns location on a given date, sun azimuths show where the sun is in relation to the time of day. The azimuths angles were important when designing a form and orientation consideration.

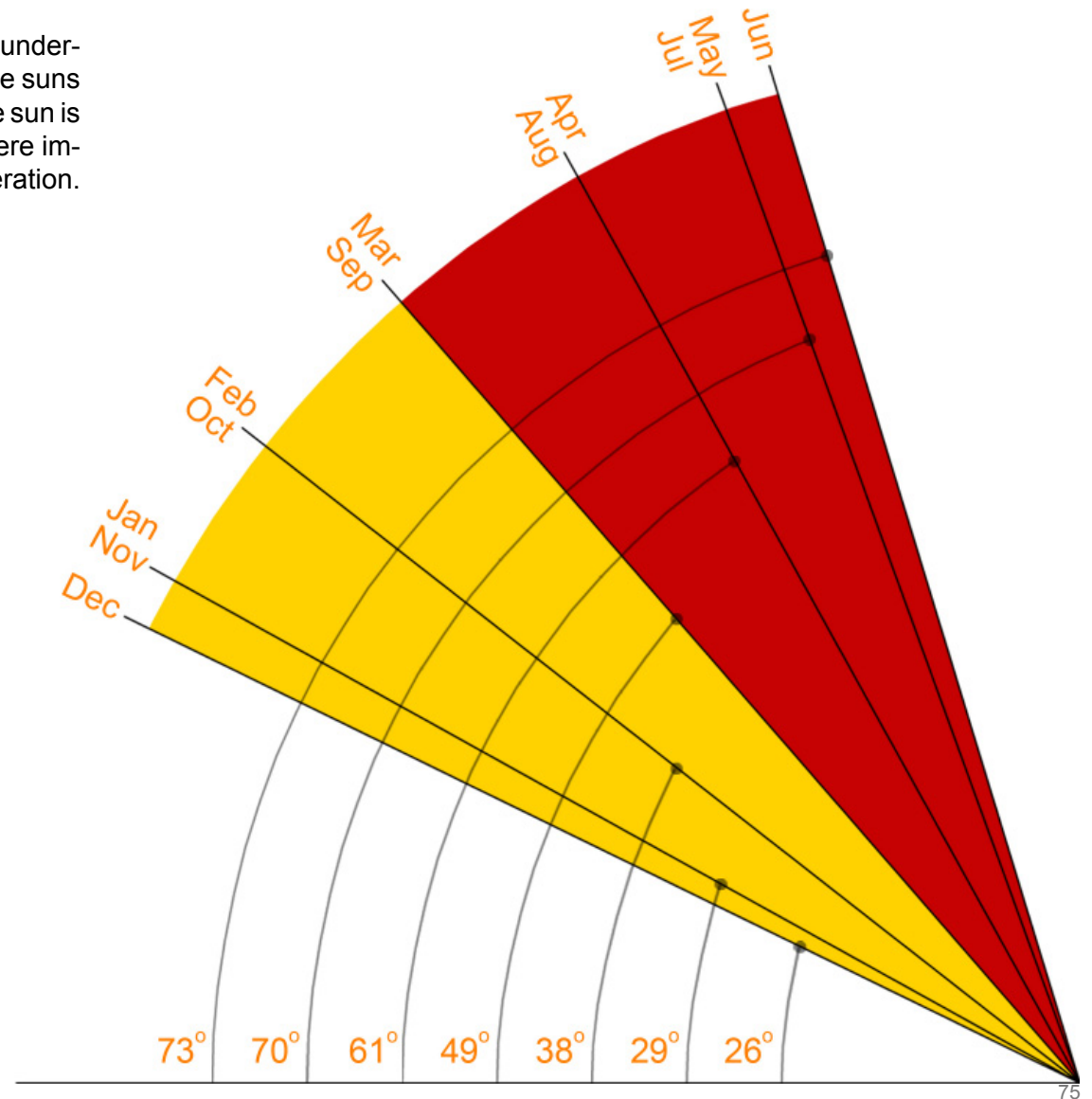

Diagrammatic Sections (sun angle studies)

After gathering the necessary geographical data, it is critical to see how each of the dwelling unit types is affected by the sun and at what times of the year. Knowing this information is crucial in understanding how to design appropriately on the site.

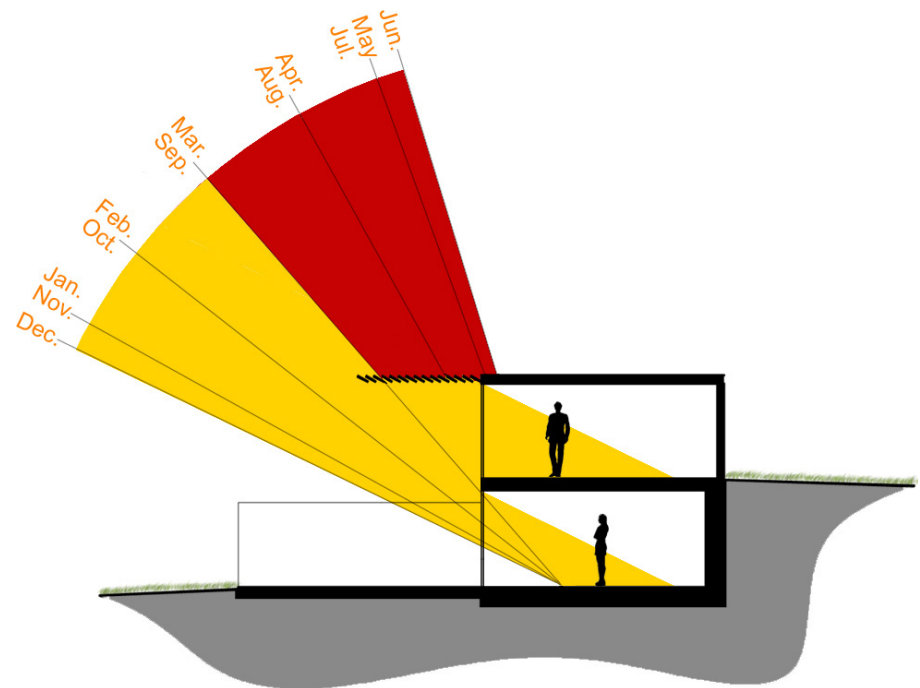
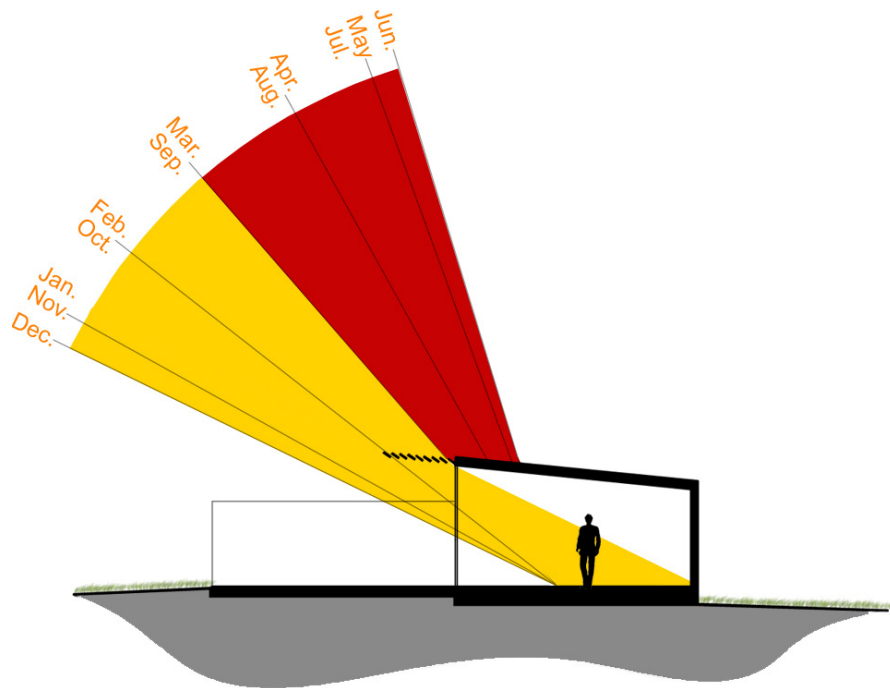
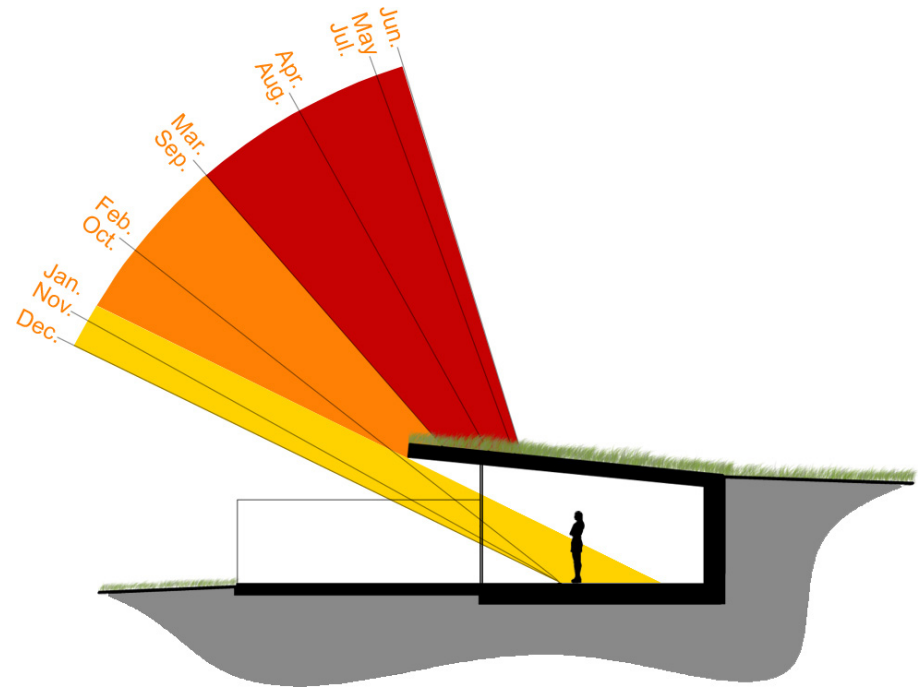

Sun Azimuths (40.89° north latitude)

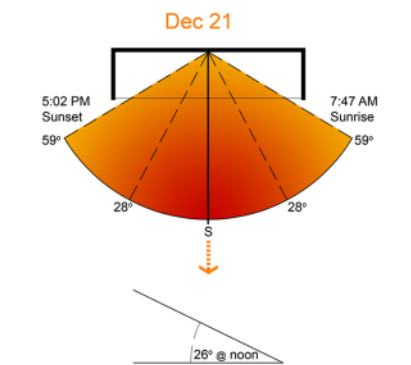
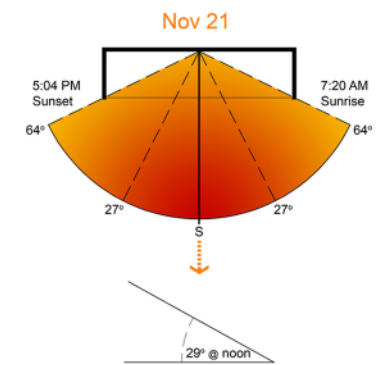
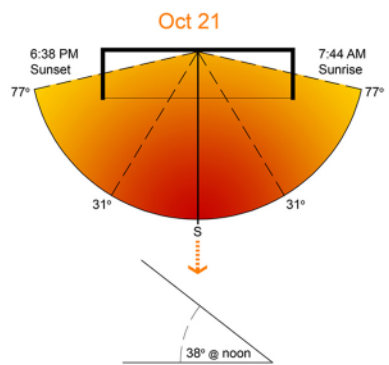
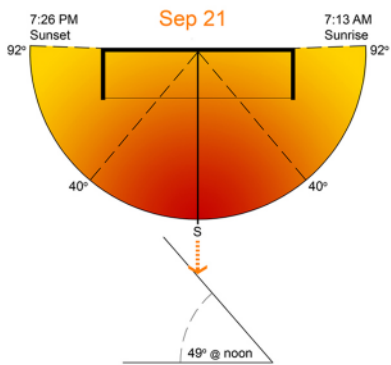
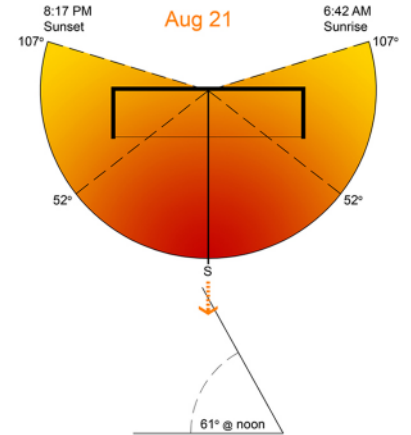
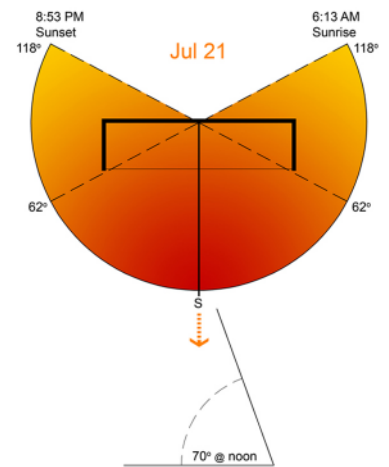
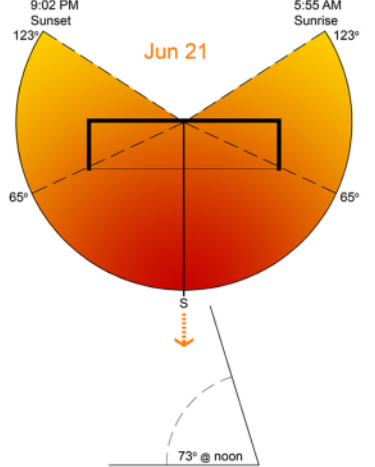
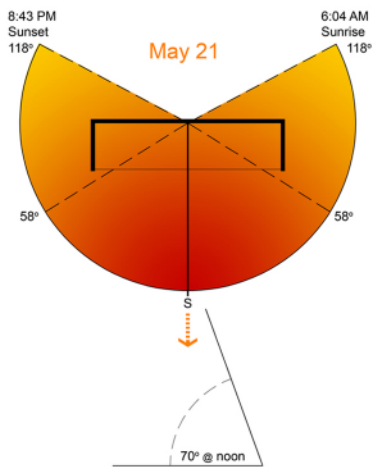
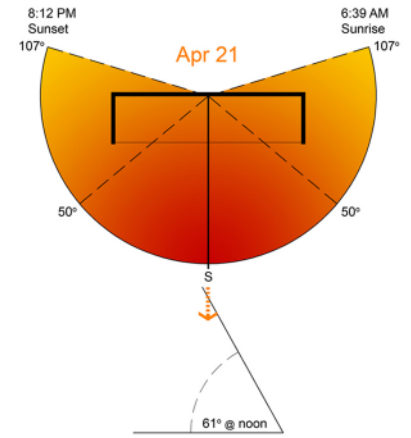
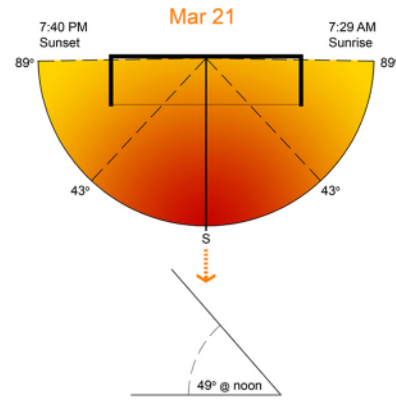
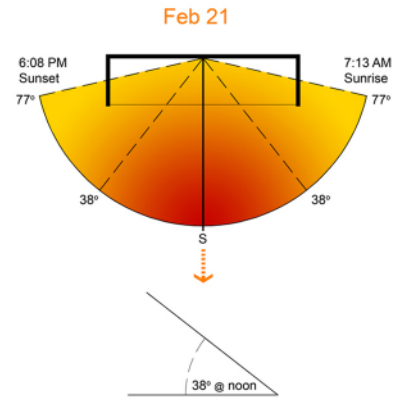
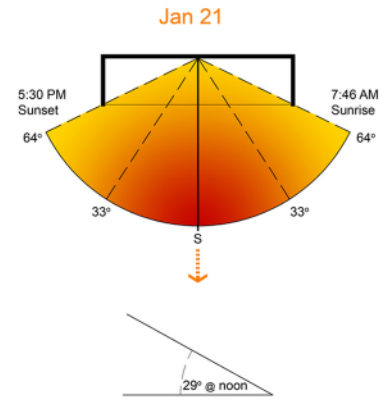

Placement Sketches

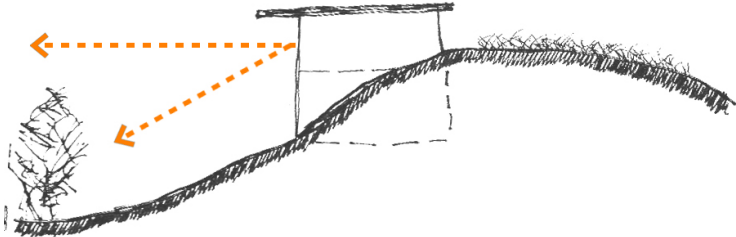

in-ground

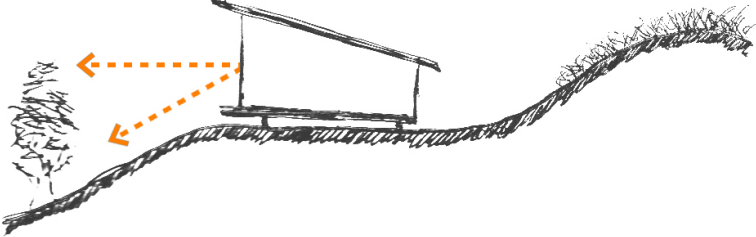

above-ground

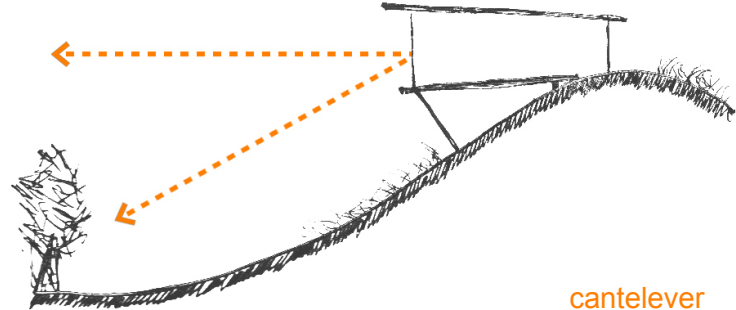

cantilever

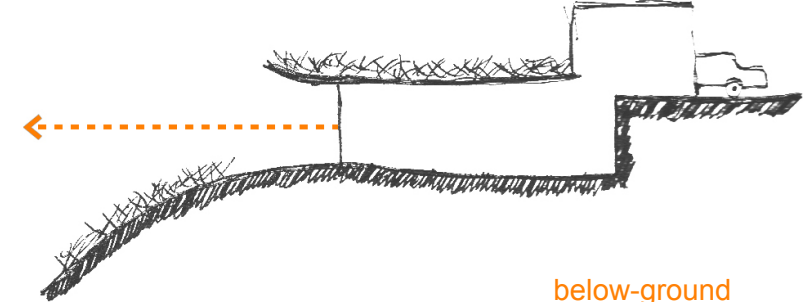

below-ground

Placement Diagrams

above-grade

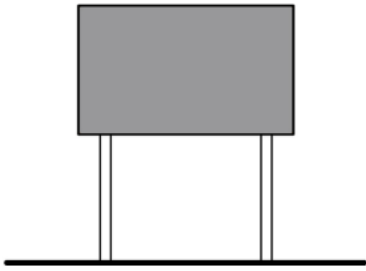

- + view
continuation of landscape
privacy
- access
wind exposure

on-grade



- + access
- limited privacy
limited view
interruption of landscape
wind exposure

in-grade

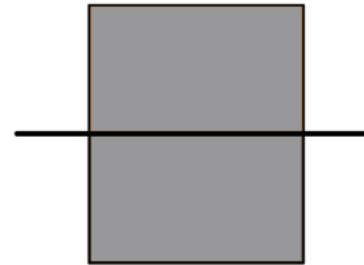

- + access
wind protection (below)
privacy (below)
thermal protection
- limited privacy (above)
wind exposure (above)
limited view
interruption of landscape
wind exposure

beneath-grade



- + privacy
wind protection
continuation of landscape
thermal protection
- access
limited view

Dwelling Arrangements

(developer concept)

The site plan on this page illustrates how a “typical developer” might arrange a series of dwellings on the site. The proximities and other relationships are derived from the existing covenants which will be exercised by the developer once construction actually starts.

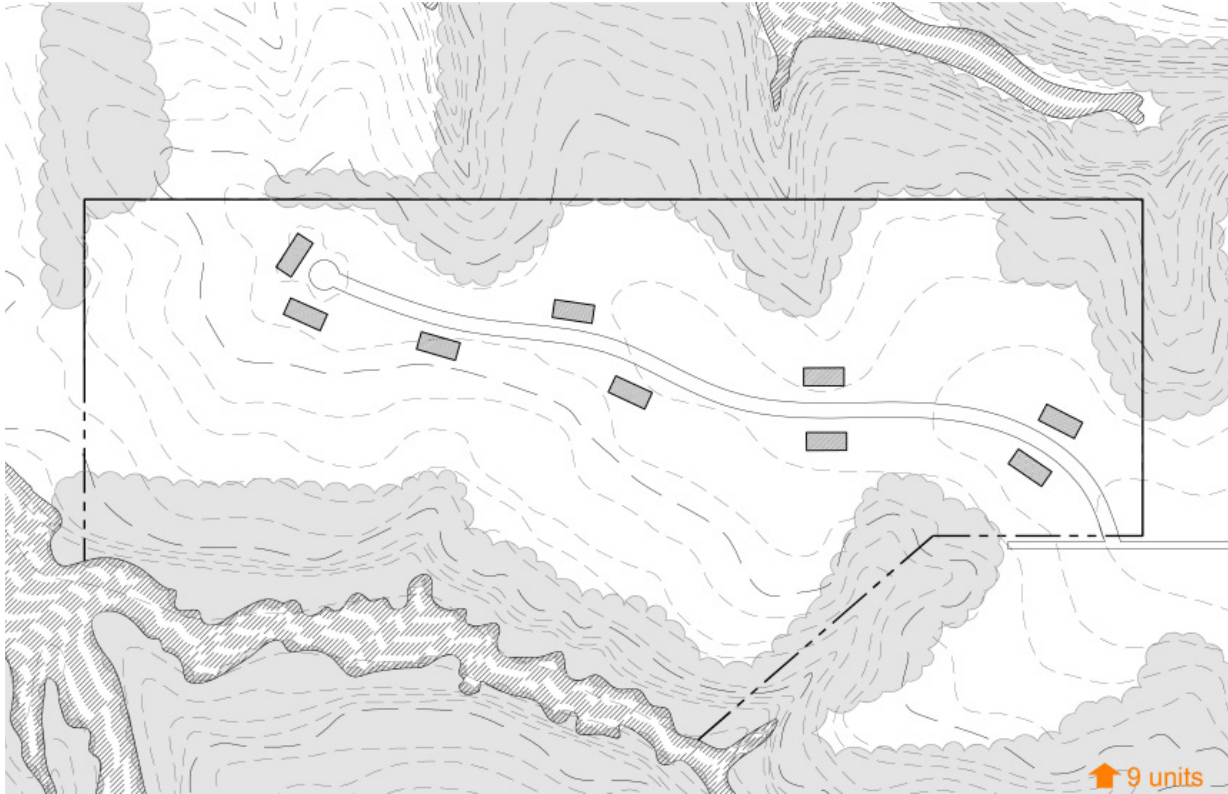

Dwelling Arrangements

(traditional concept)

The plans on this page illustrate a more passively conscience, yet traditional attempt in dwelling arrangement. The existing covenants are not used from this point on because they were deemed counter-intuitive to proper intelligent dwelling arrangement and design.

A watershed protection area has been imposed in an attempt to limit construction 150' from the water. Each of the units in these arrangements faces due south, taking full advantage of the solar gain, however the density of this cluster is minimal compared to the amount of actual buildable area.

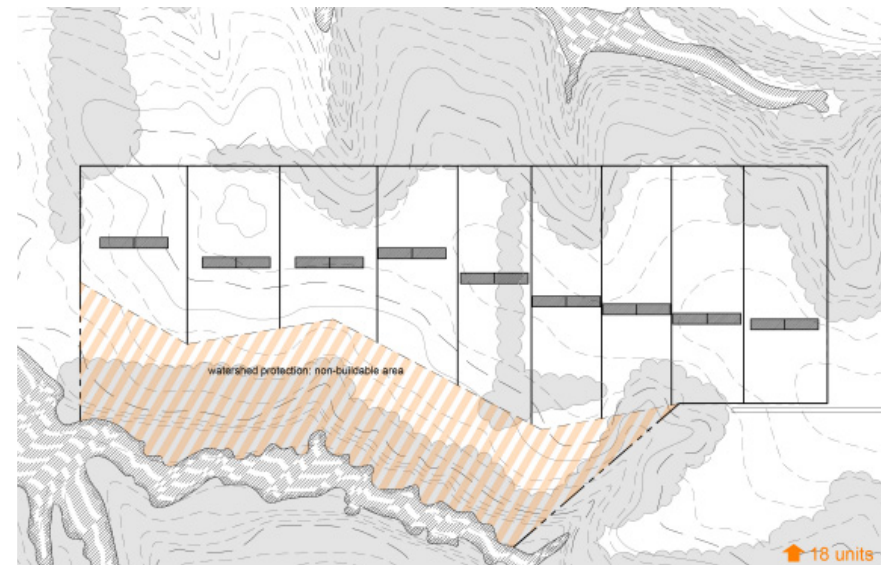
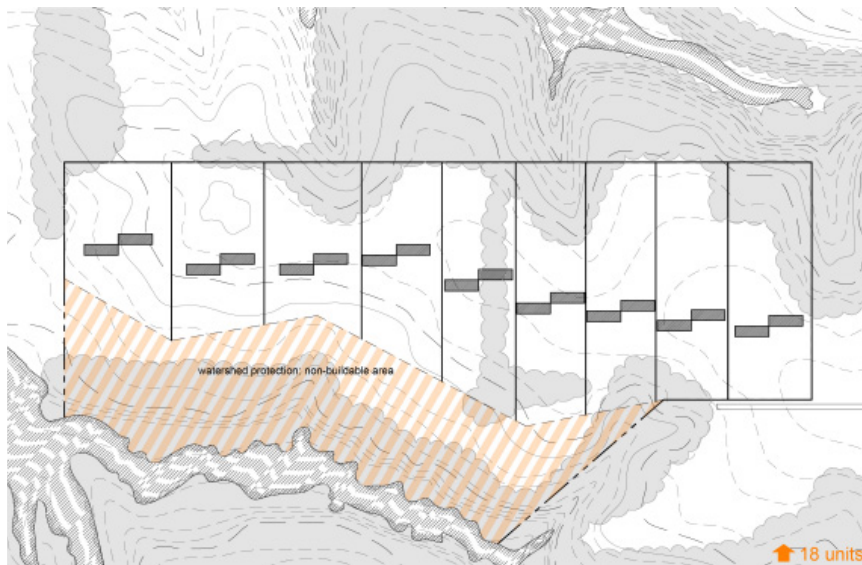
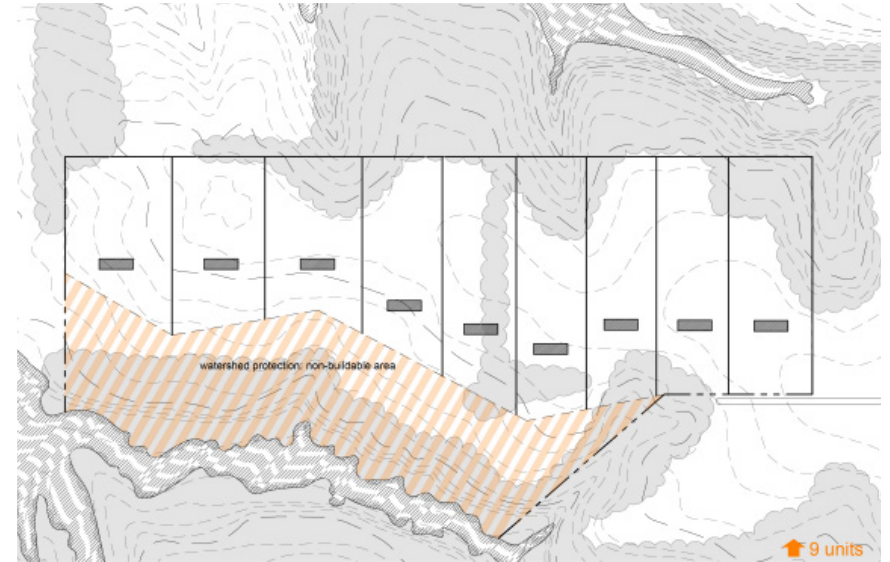

Dwelling Arrangements

(contour concept)

After analyzing the works of Glenn Murcutt, a set of contour-style arrangements were done. In this series, each dwelling was given a set amount of property, but each dwelling was restricted to being aligned with the natural contours of the site.

The introduction of communal buildings was also performed in this series. The intent of those buildings was to provide a storage or gathering area for the residents of the cluster.

The overall density was increased, however relying strictly on the natural contours for arrangement limited the number and form of potential dwellings.

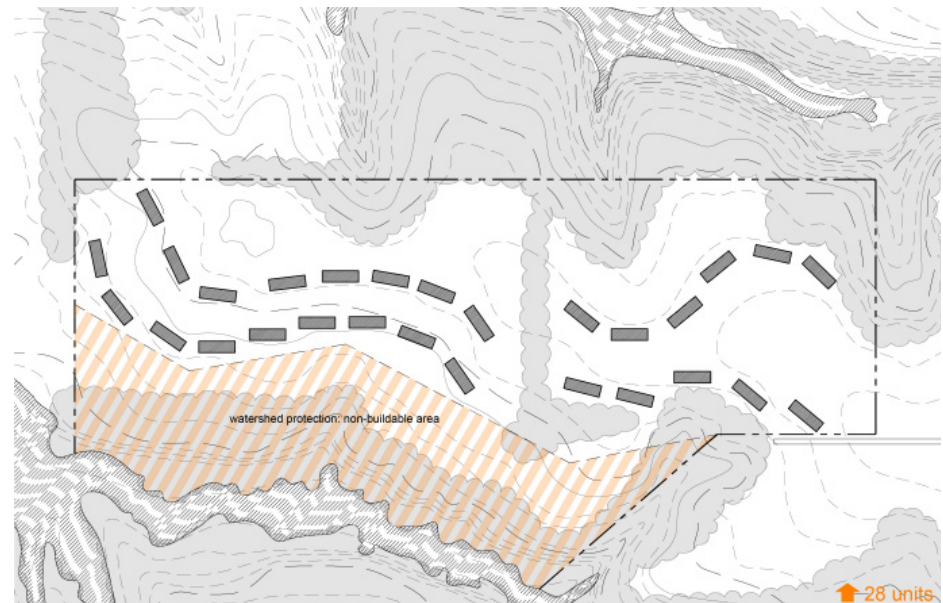
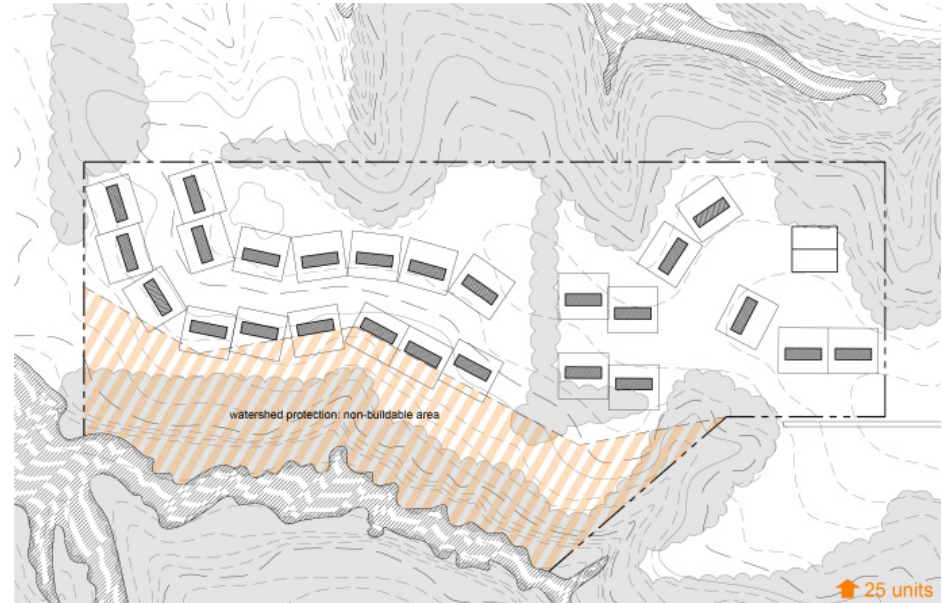

Dwelling Arrangements

(fredensborg concept)

The Houses at Fredensborg were a strong catalyst behind this series of arrangements. Every dwelling unit shown in these is a courtyard-style dwelling.

Like the contour arrangements, these too also align themselves to the natural contours of the site. Although the number of dwellings increased, the negative aspects of summer solar gain were exposed.

The courtyard-style house did however have many advantages for several locations on this site, therefore this style or form is appropriate the challenge at hand.

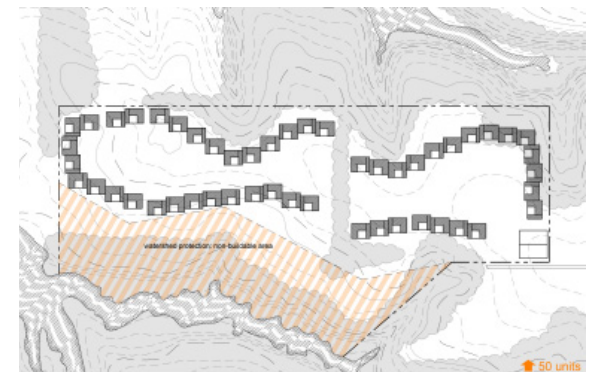
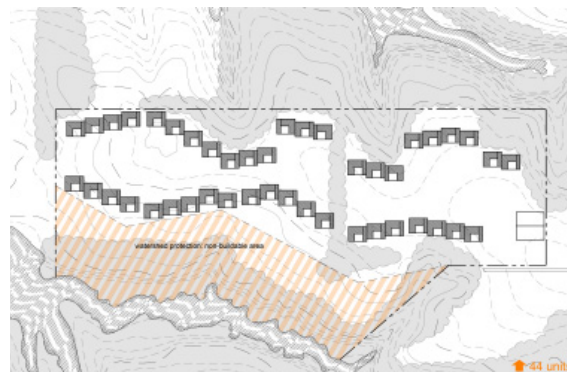
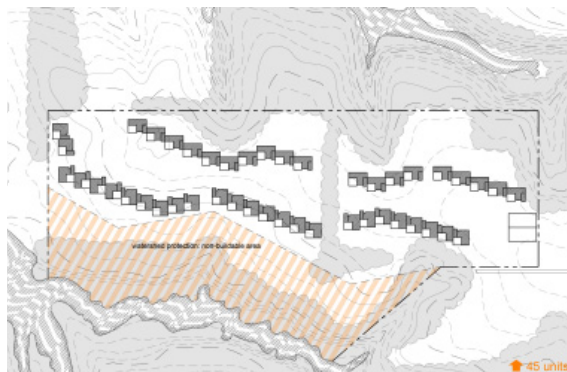
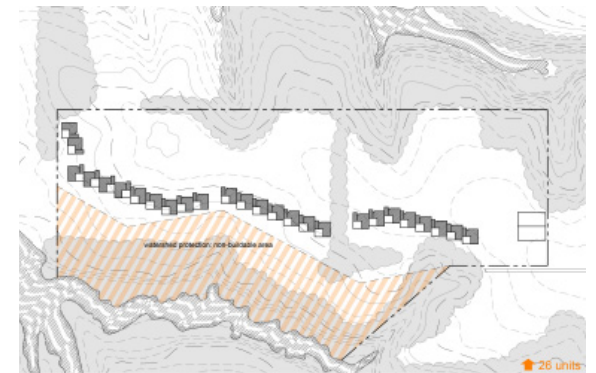
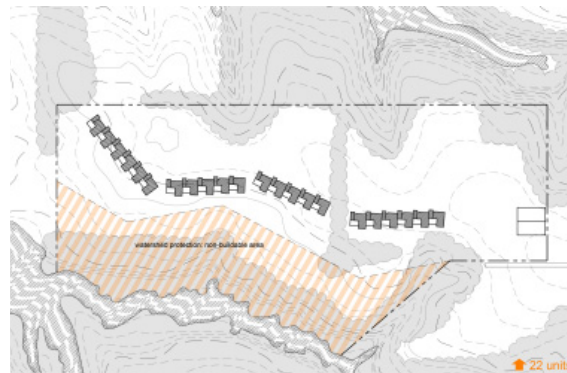

Dwelling Arrangements

(solar concept)

This series of arrangements is similar to that of the traditional, but also to the contour arrangements. The density of each arrangement varied and the orientation was strictly limited to due-south only.

The arrangements in this series do have many benefits as far as performance is concerned, however the communal and social aspects of the dwellings comes into question. The rigidity and almost sterile layout almost resembles block housing, which is not a desired quality.

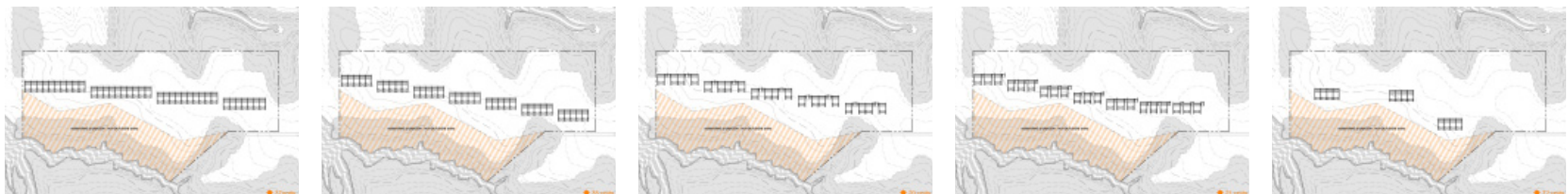
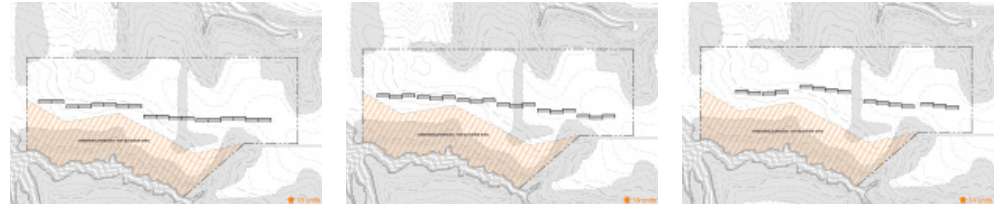

Dwelling Arrangements

(communal concept)

This last series incorporates the benefits of all previous arrangements in an effort to provide a dwelling arrangement that address the geographical, privacy, communal, and social aspects of the site and its possible occupants.

The community center aspect has been enhanced and could be a place for possible post office, recreation center, office area, and co-op grocery store. Those living on the site could take full advantage of these opportunities, which will help them cope in a post-fossil world.

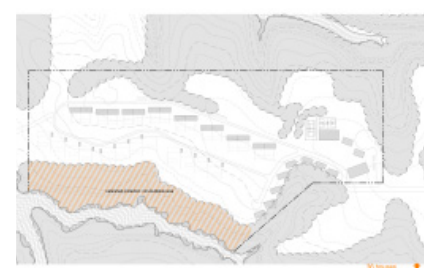
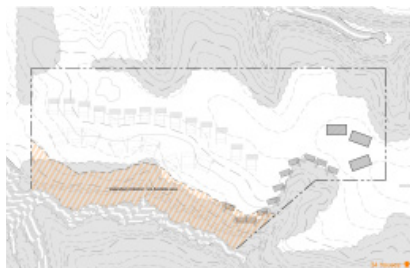
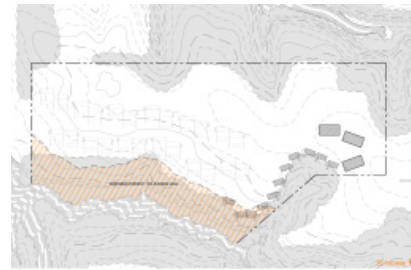
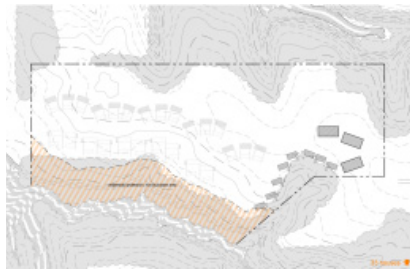
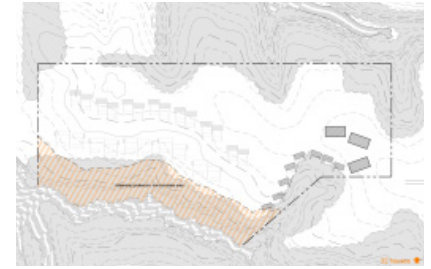
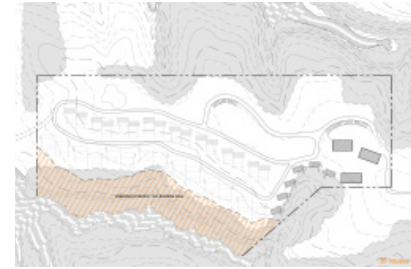

Concept Plan

After doing site analysis and arrangement studies, a series of concept or prototype plans will be developed. Each plan will have similarities to each other, incorporate the best and most appropriate aspects of the precedent studies and finally not include any of the common mistakes found in the case studies.

The plan on this page shows a typical dwelling, while the diagram on the opposite page shows the disadvantages of said dwelling. What this diagram illustrates clearly is that the orientation of the dwelling, whatever the form, should be in the east-west direction. By doing this, the passive solar abilities of the dwelling will be enhanced while the negative aspects of western exposure will be minimized.

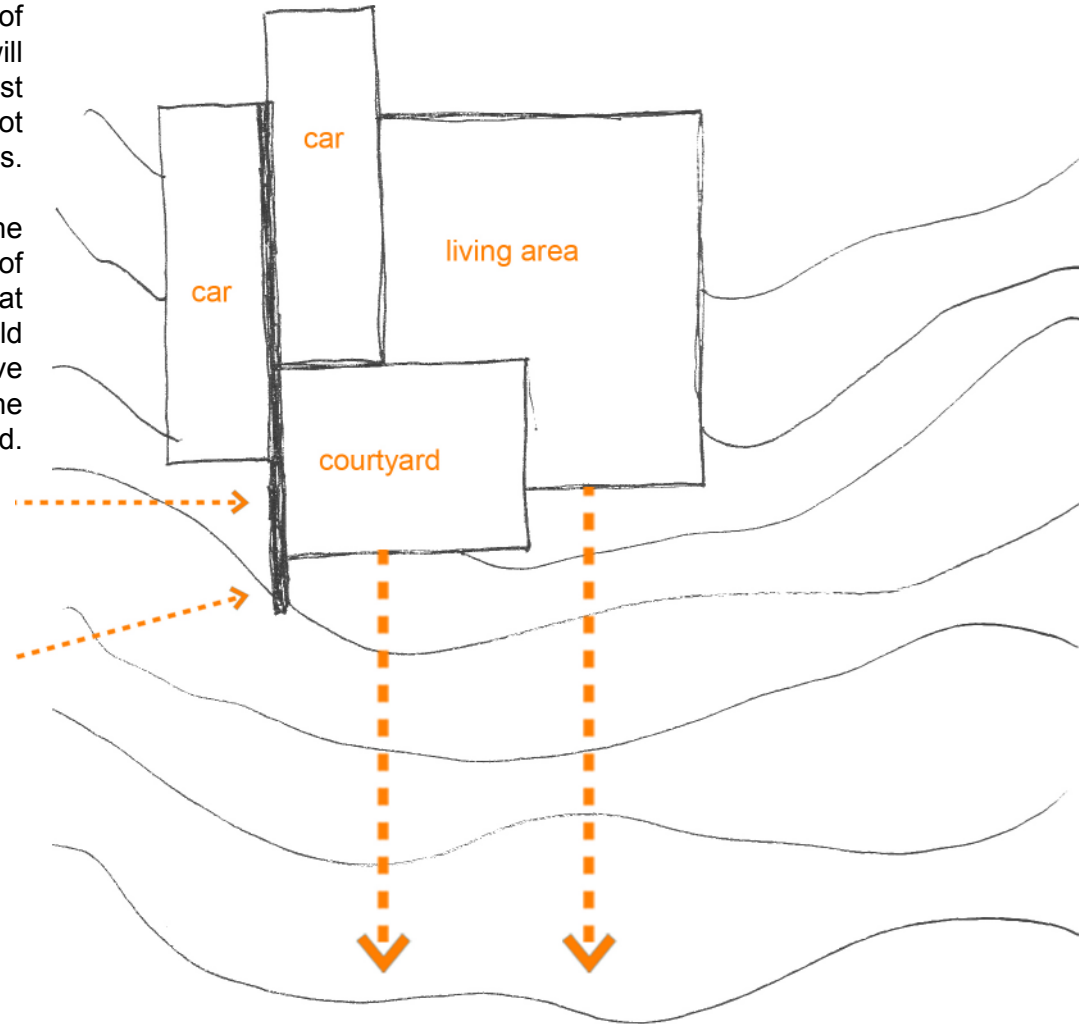

Concept Plan-Exposure

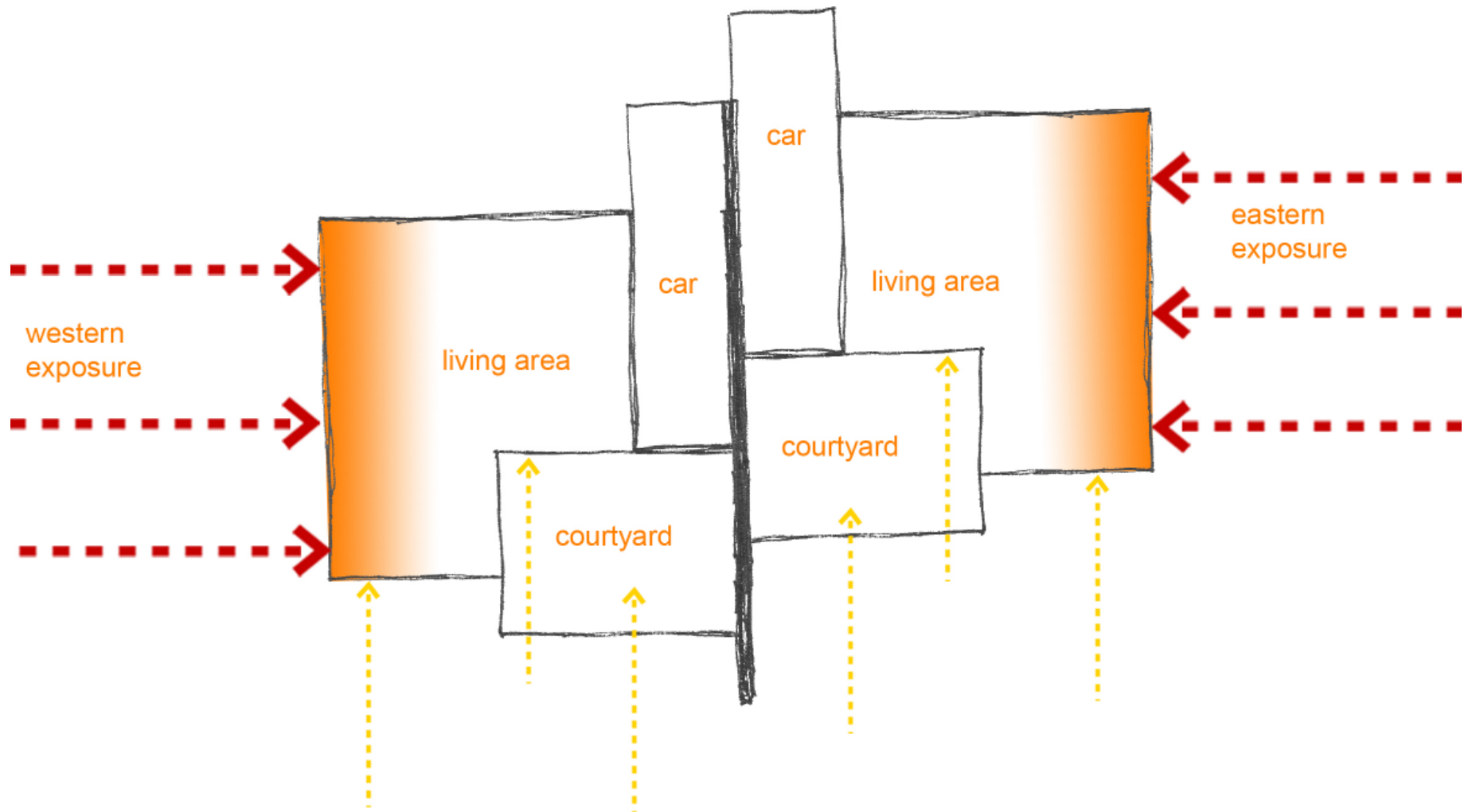

Diagrammatic Plan

(upper level)

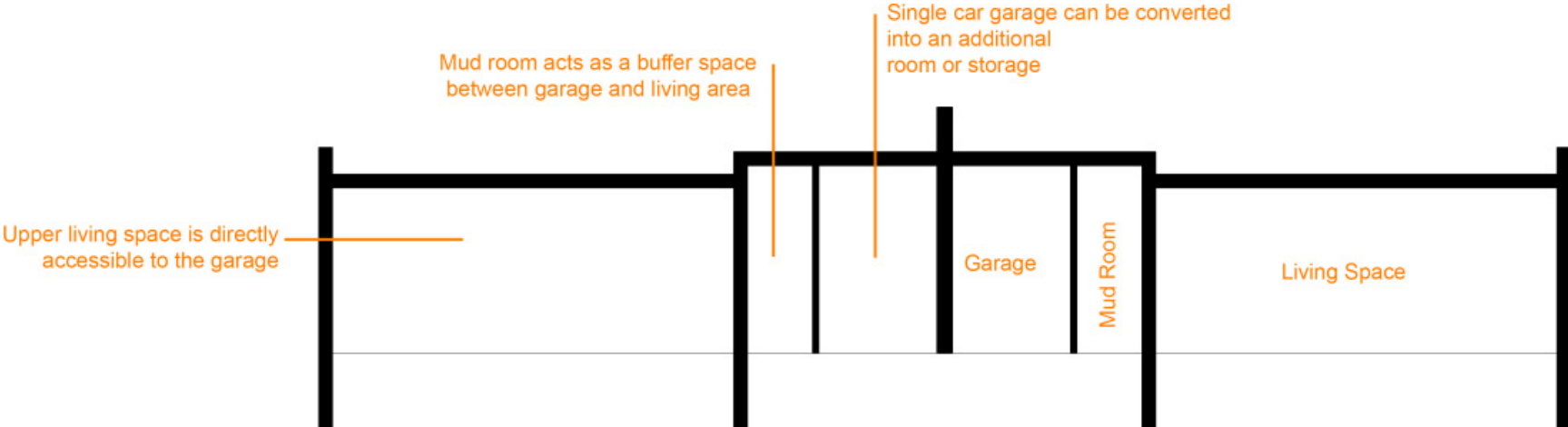

Diagrammatic Plan (lower level)

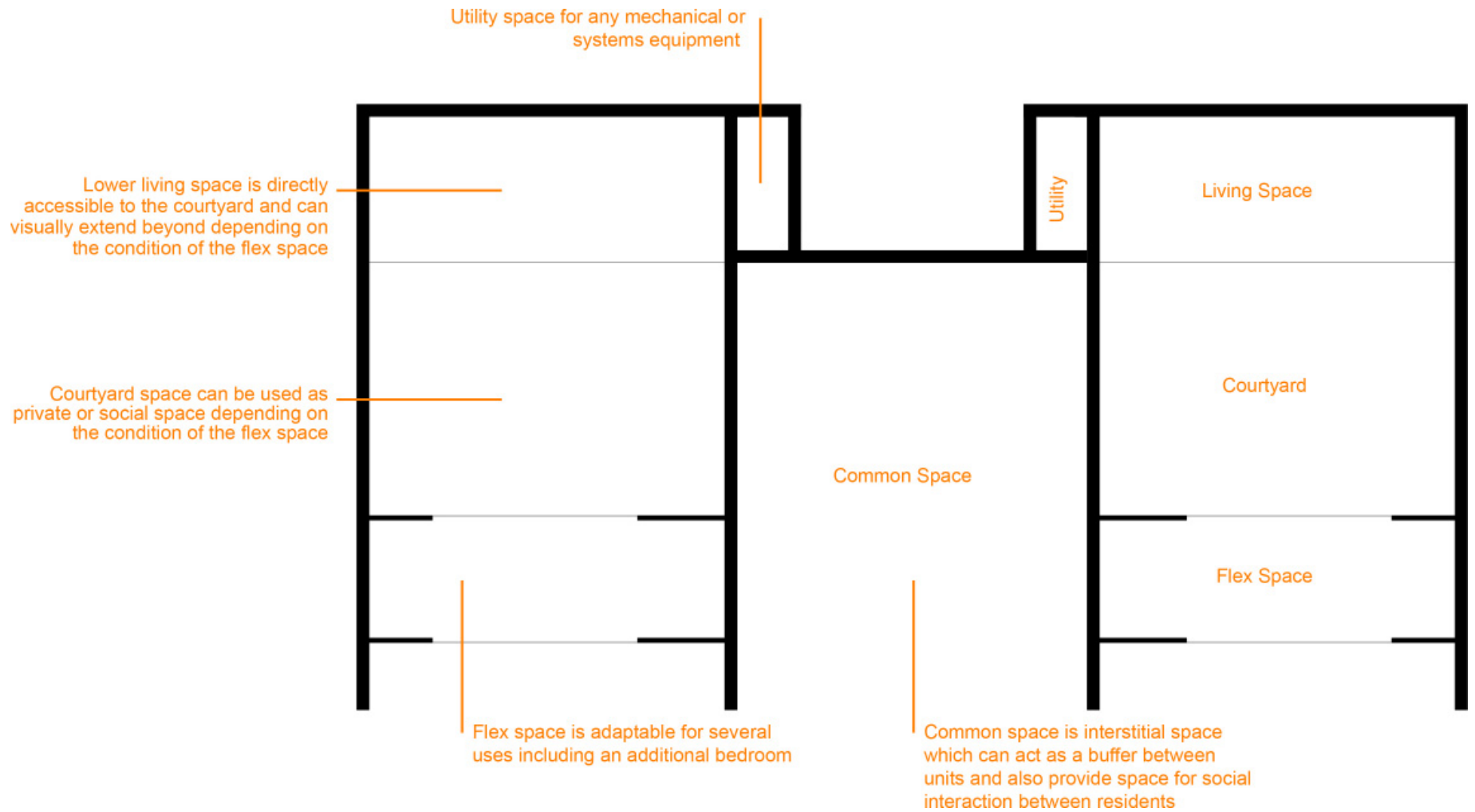

Diagrammatic Section (above ground prototype)

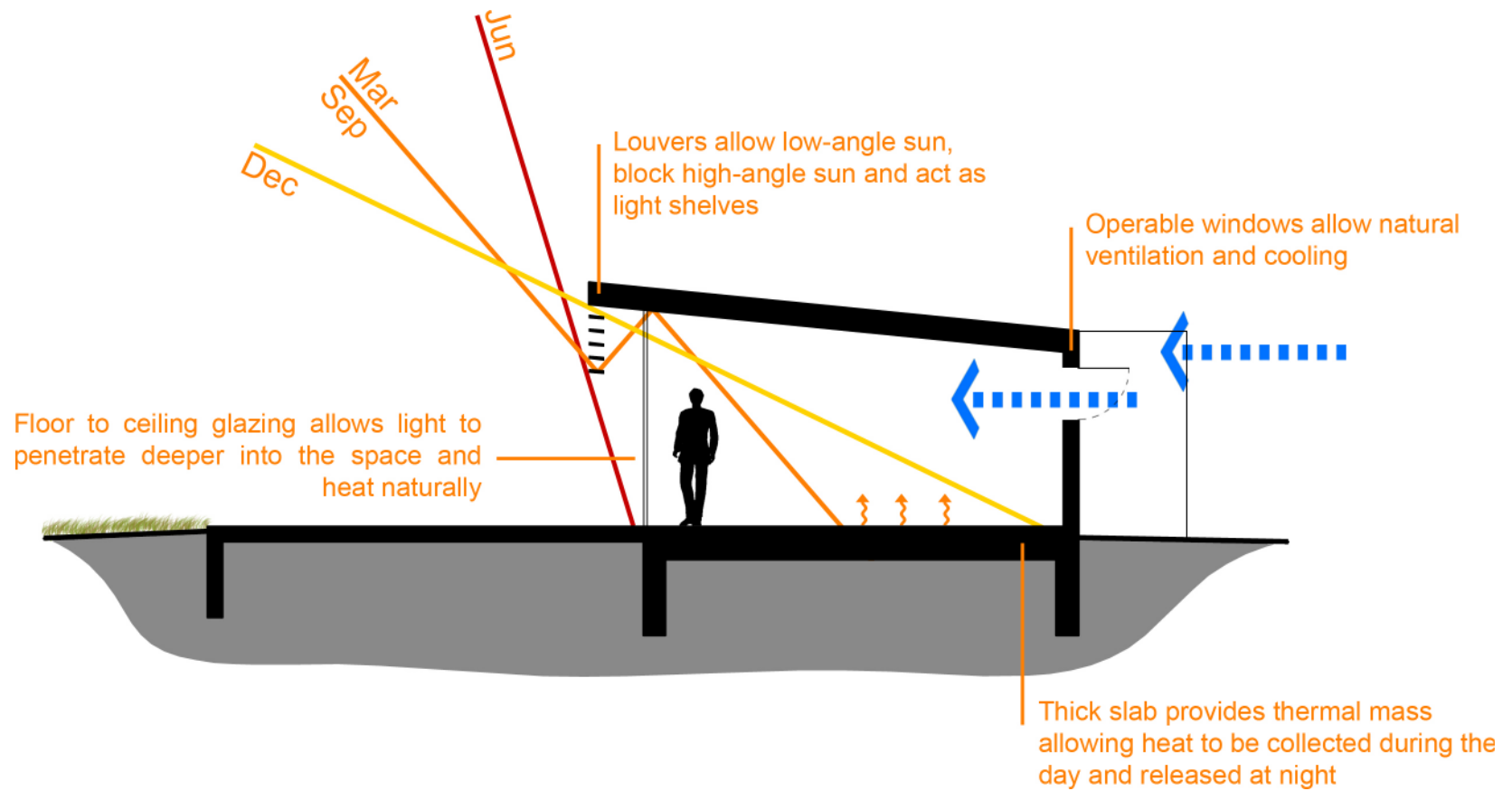

Diagrammatic Section

(above ground w/ courtyard prototype)

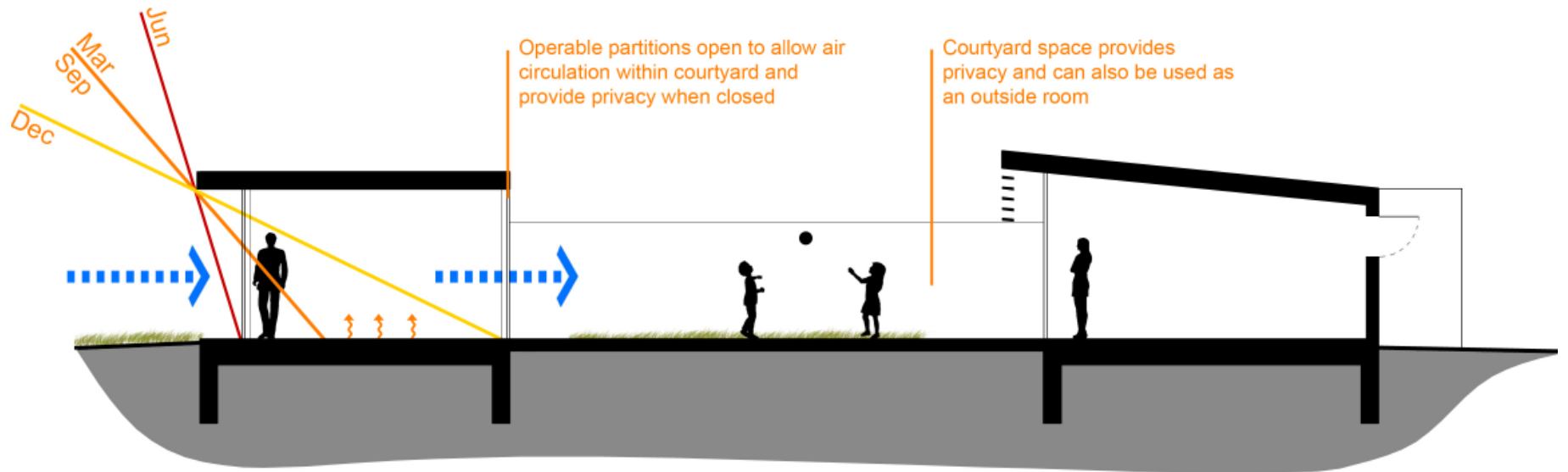

Diagrammatic Section (under ground prototype)

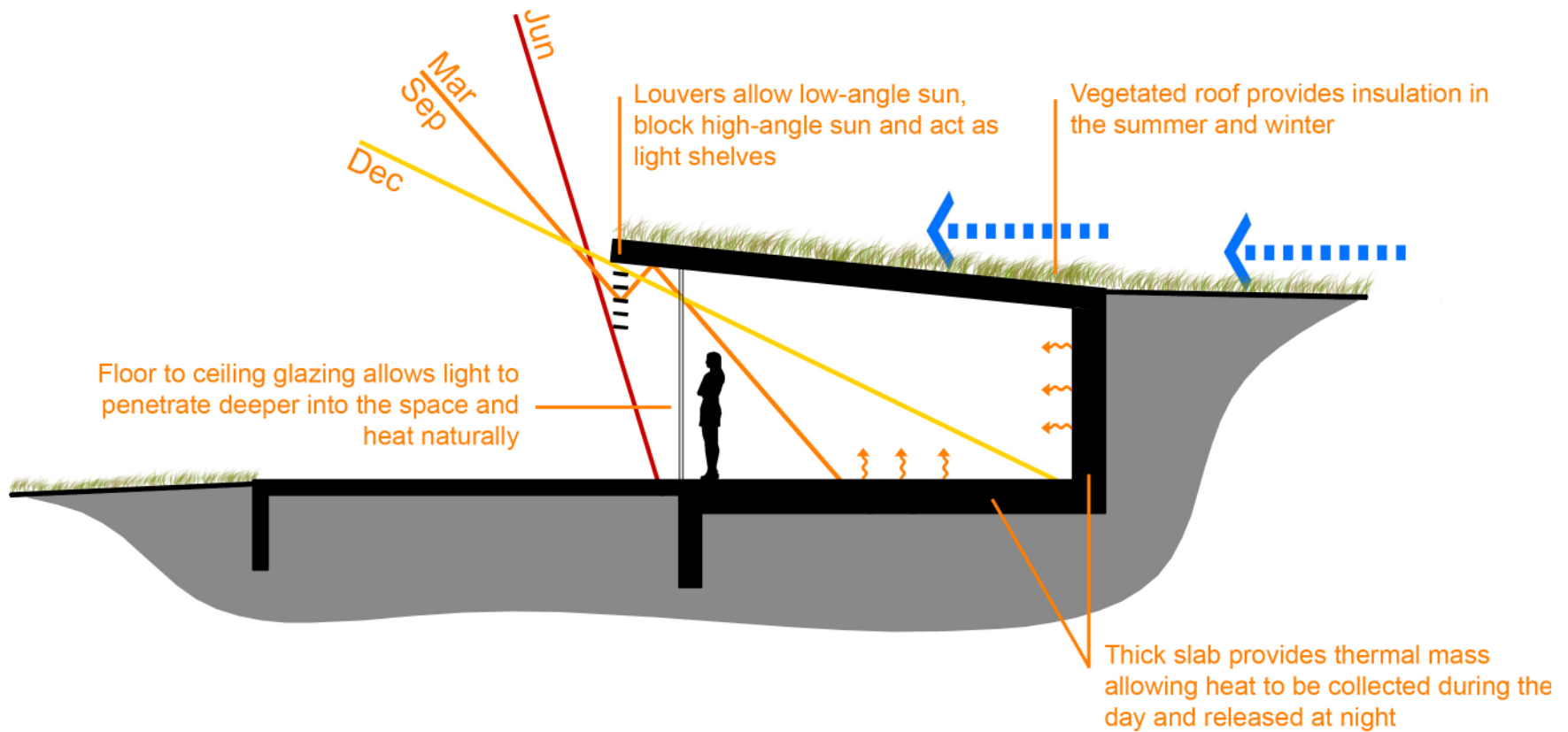

Diagrammatic Section

(under ground w/ courtyard prototype)

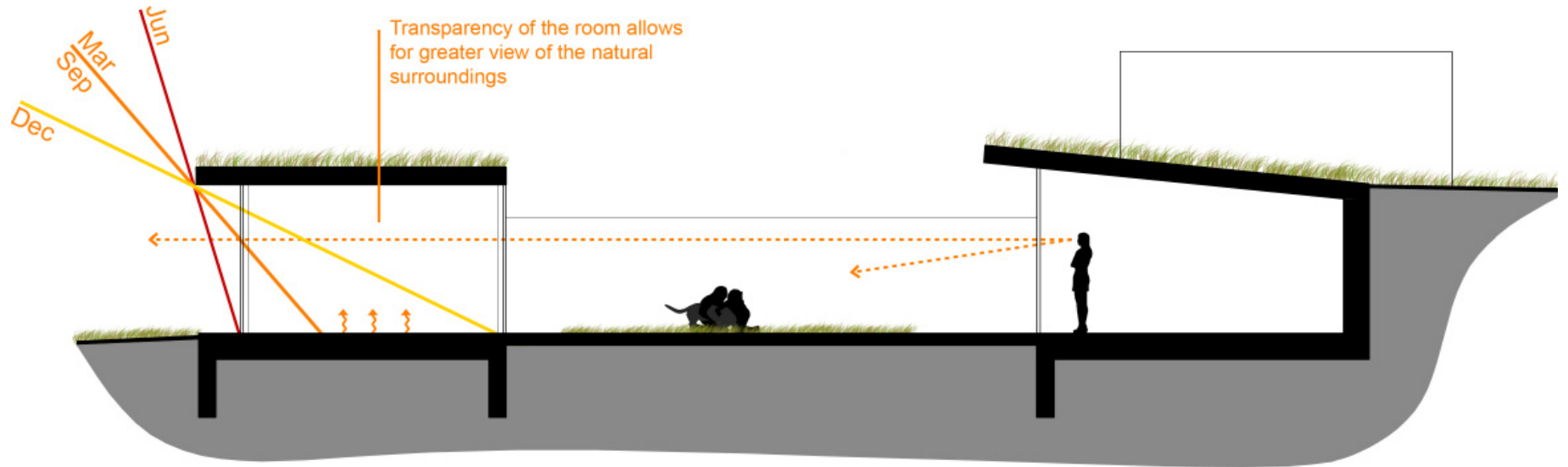

Diagrammatic Section (combination prototype)

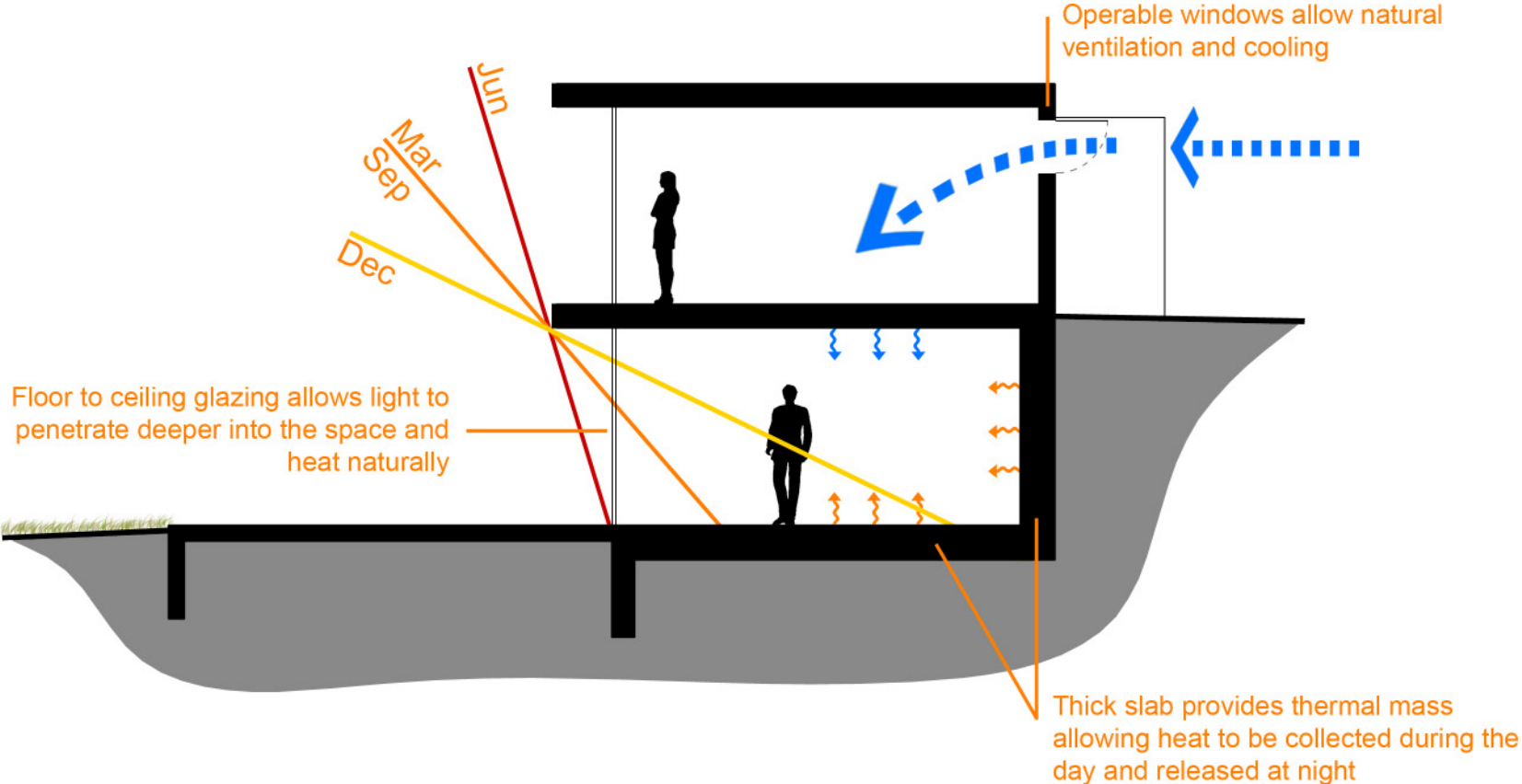

Diagrammatic Section (combination w/ courtyard prototype)

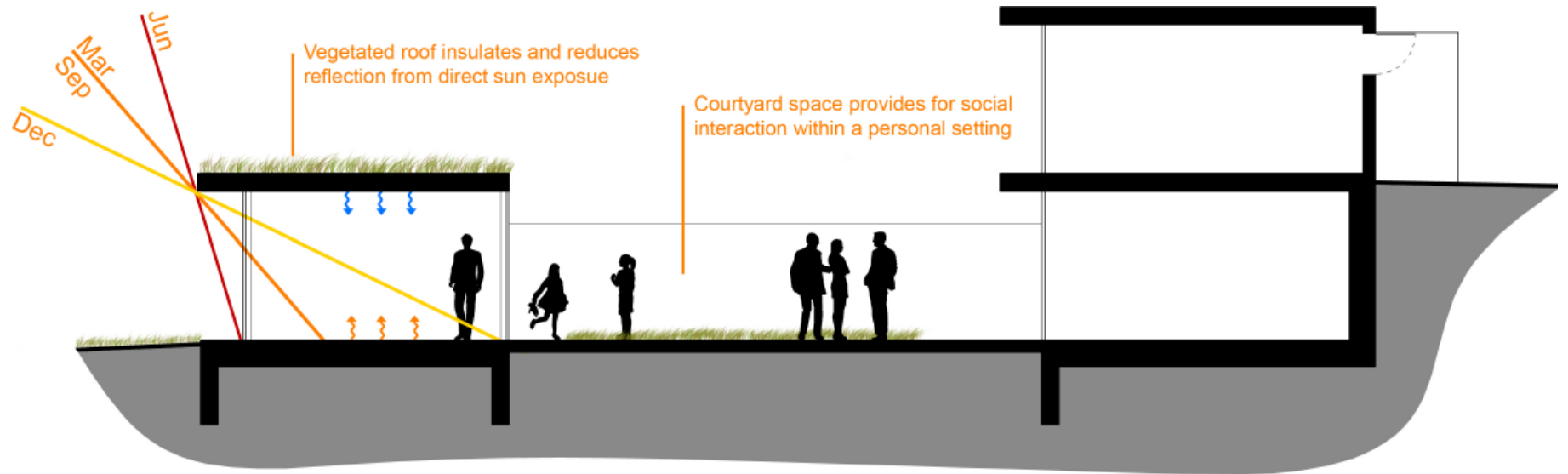

Diagrammatic Section (combination prototype)

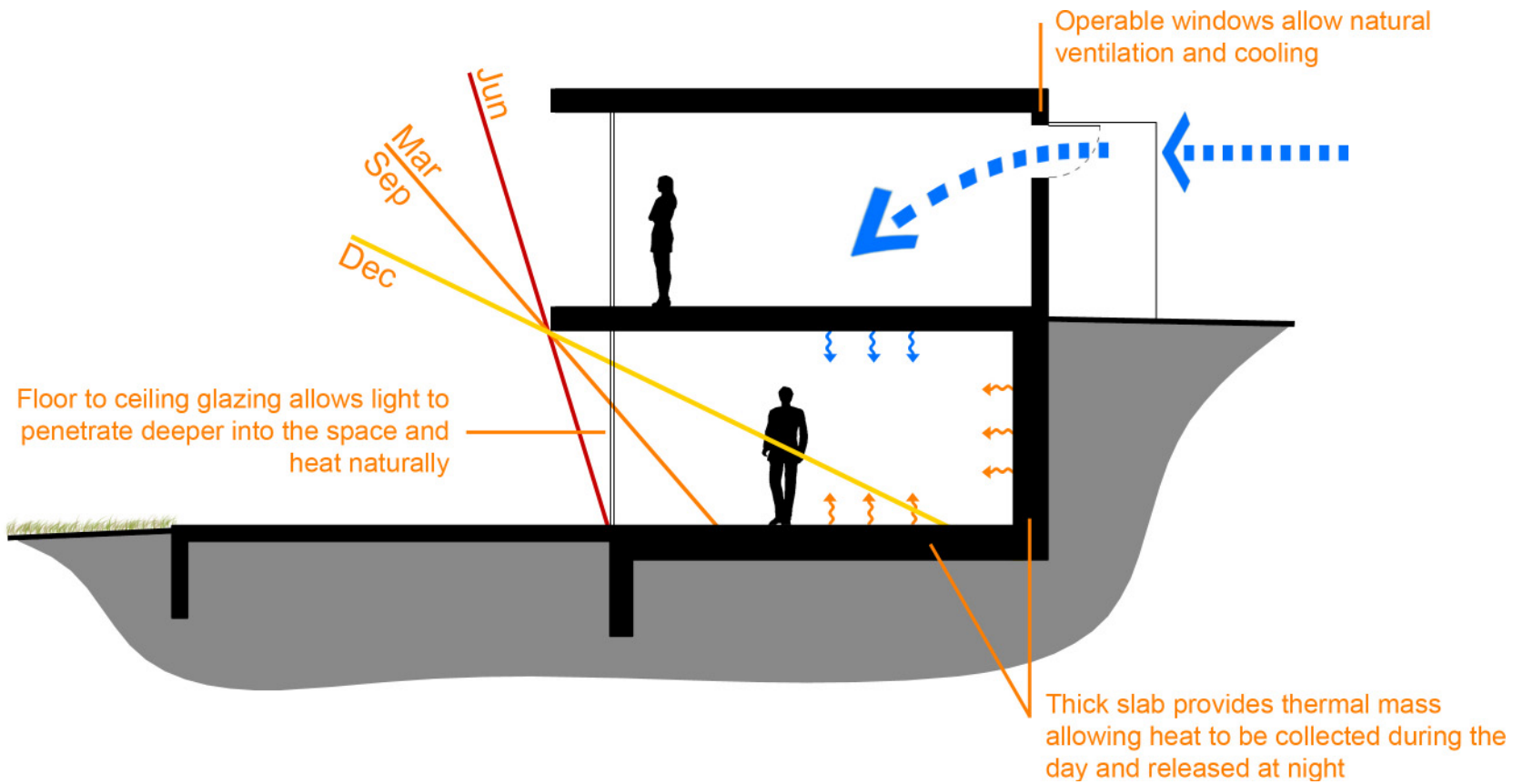

Diagrammatic Section (combination w/ courtyard prototype)

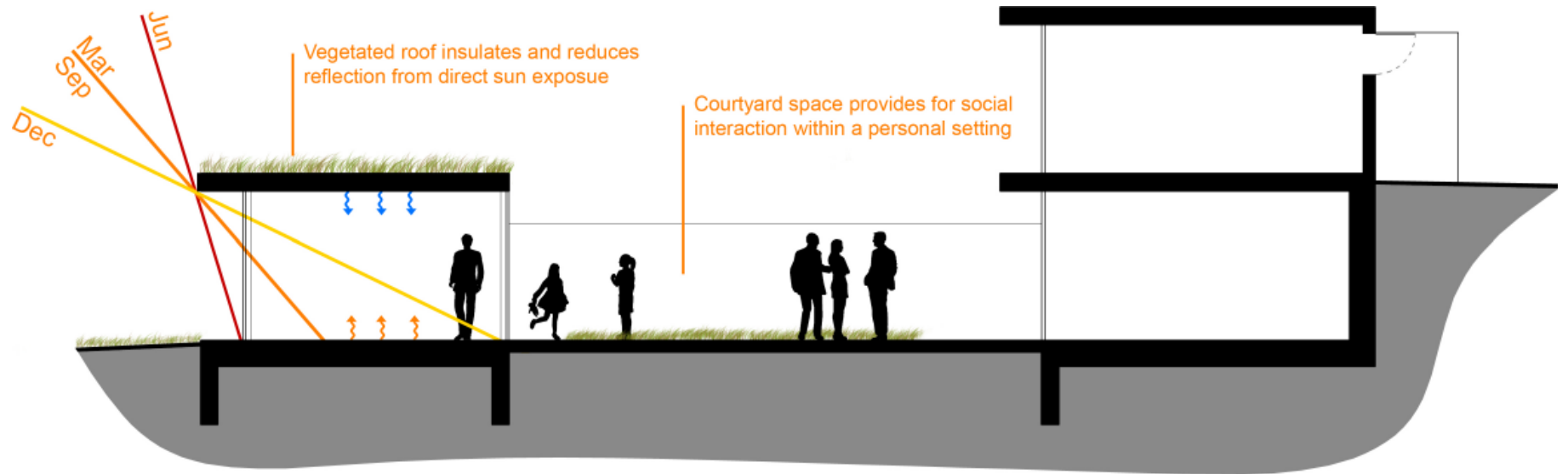

Diagrammatic Section

(earth home sun study)

The diagrams on this page show how structural shading devices such as an overhang can keep the unwanted summer sun out, and allow the low-angle winter sun in. The amount of structural cantilever had to be calculated so that the sun did not hit the glass on June 21.

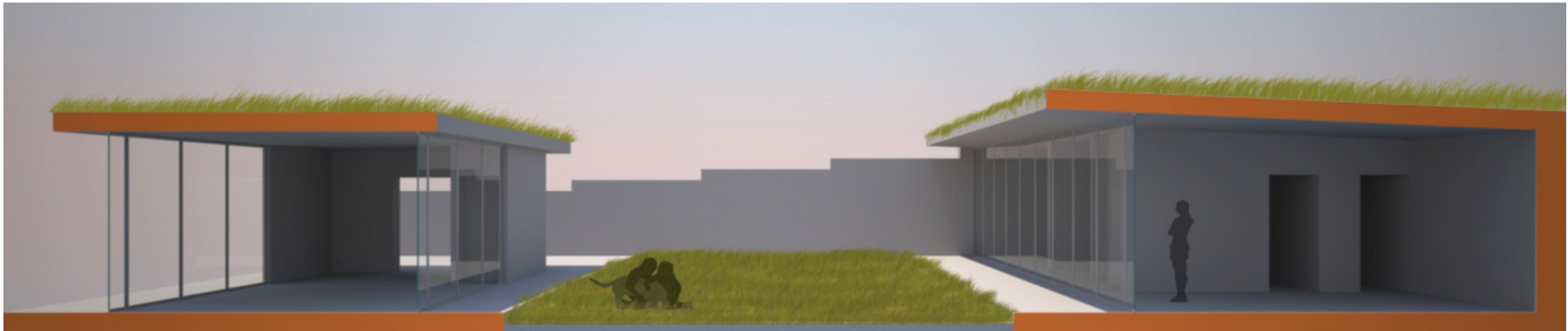

june 21 @ noon



december 21 @ noon

Diagrammatic Section

(berm home sun study)

In addition to structural shading, in-glass louvers can be incorporated to keep out any unwanted sun, but also increase privacy. The louvers can be laminated with thin film photovoltaics so that when they are closed, they generate energy when the sun hits them.

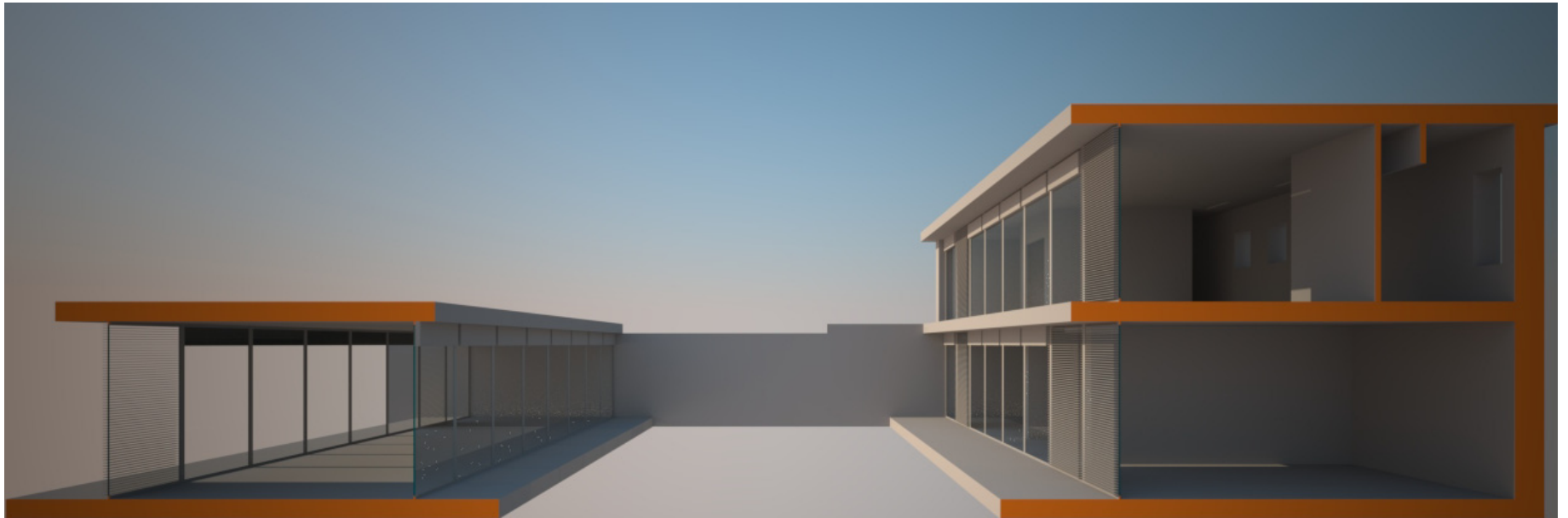

december 21 @ noon

Diagrammatic Site Plan

Once the site analysis and precedent studies had been performed, three distinct areas of the site were chosen for dwelling units. Each of the areas have unique characteristics which allow for three different type of dwelling, noted in green, blue and brown.

In addition to the dwelling areas, communal areas have also been established, noted in orange.

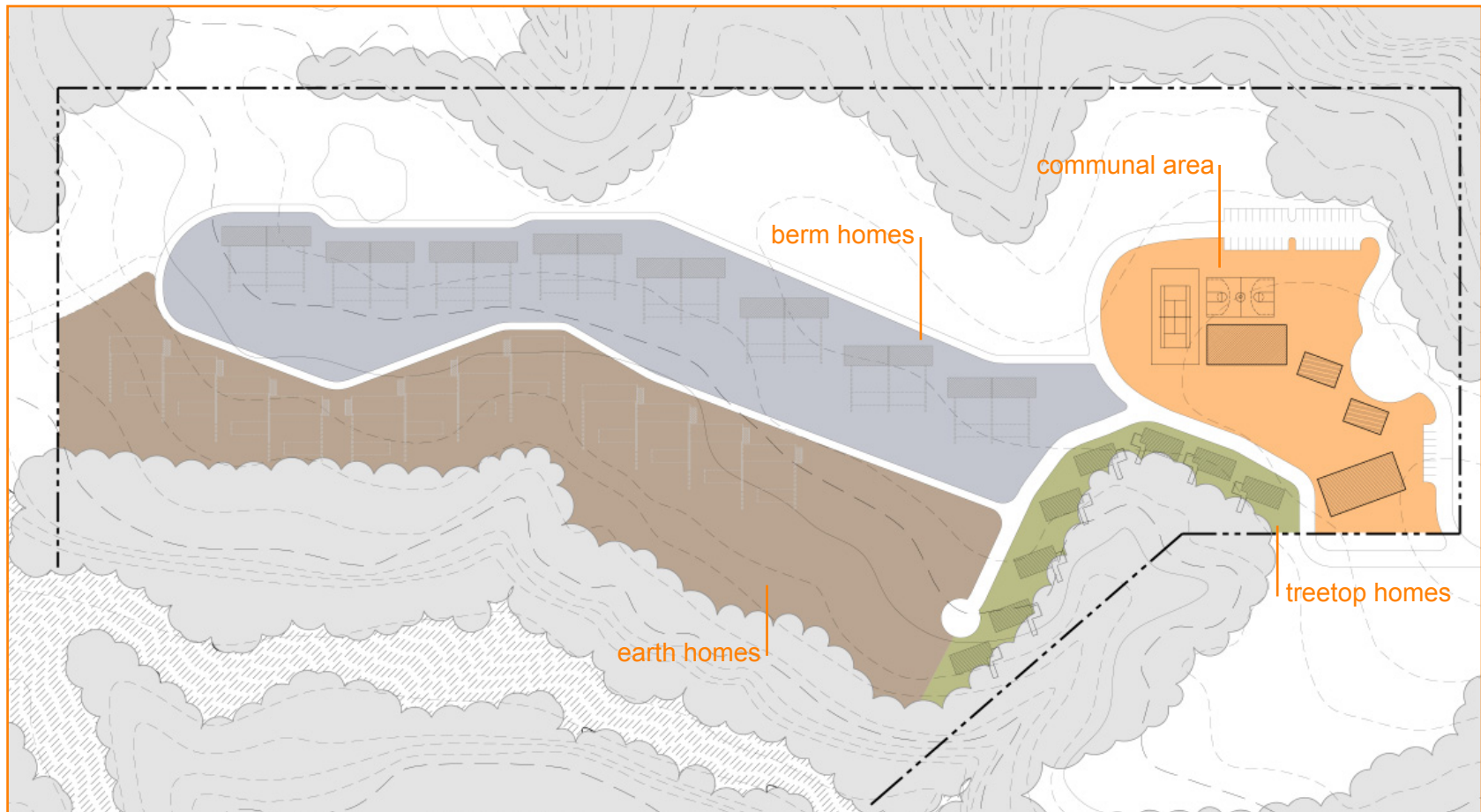

Schematic Site Plan

Entry to the site will be from the east. The main access road will lead into the community center which will act as a buffer and gateway into the site. A private, one-way access road will circumvent the site. This road will be constructed of a pervious material. Parking for the dwellings will be provided at the community center and also at each dwelling.

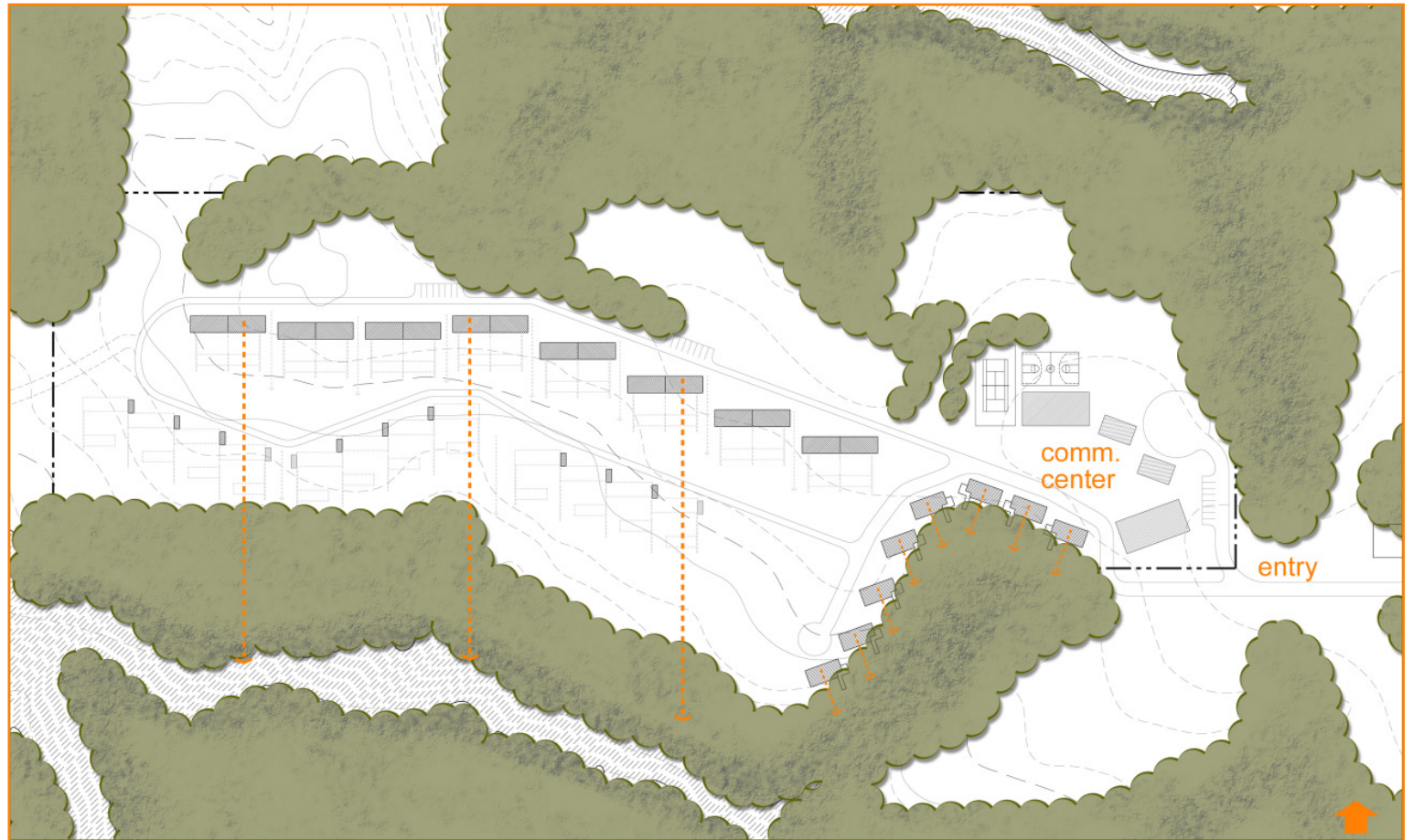

Concept Sketch

(berm concept)

The berm concept, noted in blue on the site plan is located at the top of the hill. The idea here is to provide a multi-level space which takes advantage of the commanding views, while being nestled into the the hill. The Solar Hemicycle house was a strong influence on the form of this dwelling.

By coupling the ideas behind the Solar Hemicycle and the courtyard house, the berm house provides a high degree of passive solar ability with the privacy and function required for a successful dwelling.

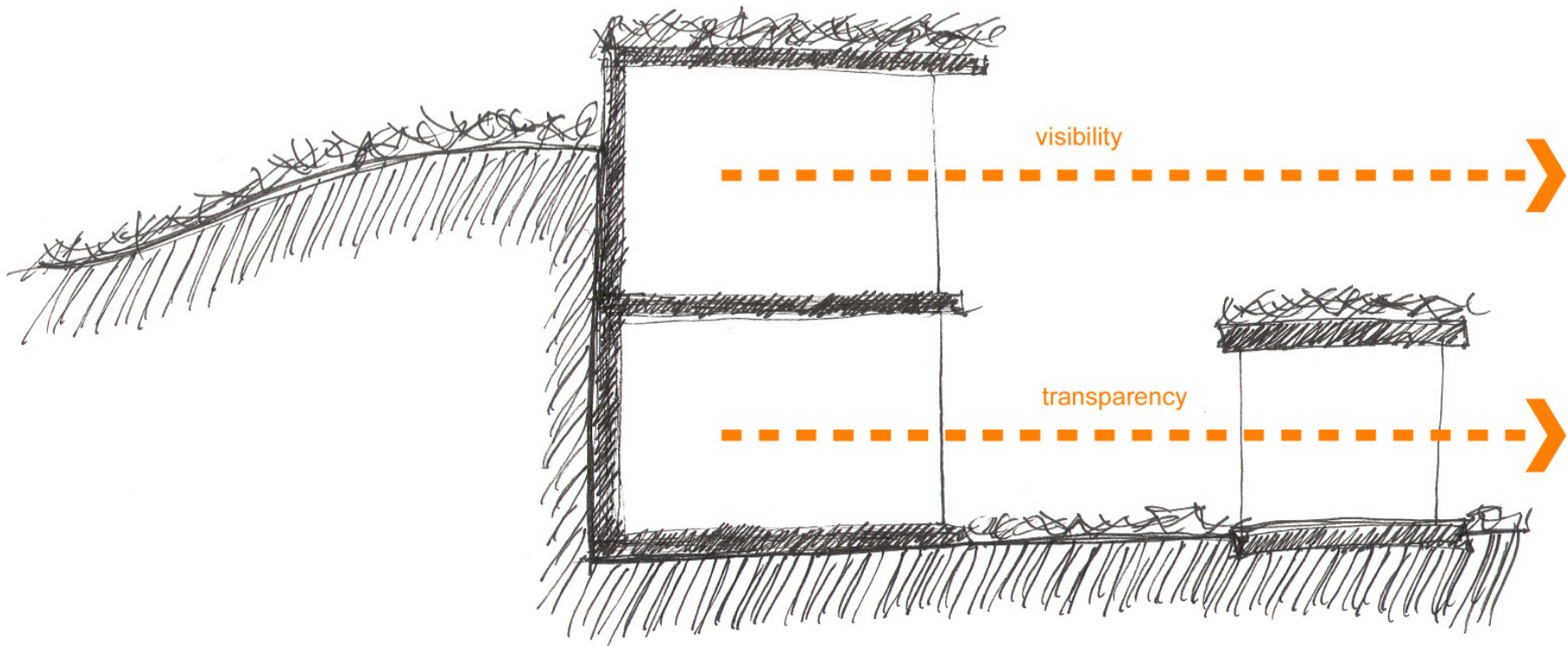
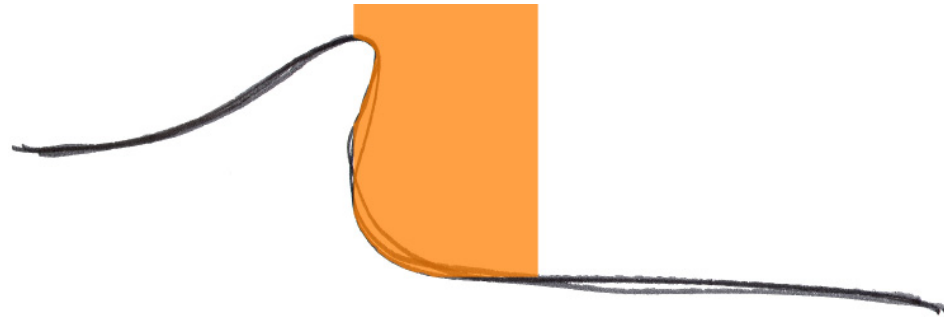

Massing Model

(berm concept)

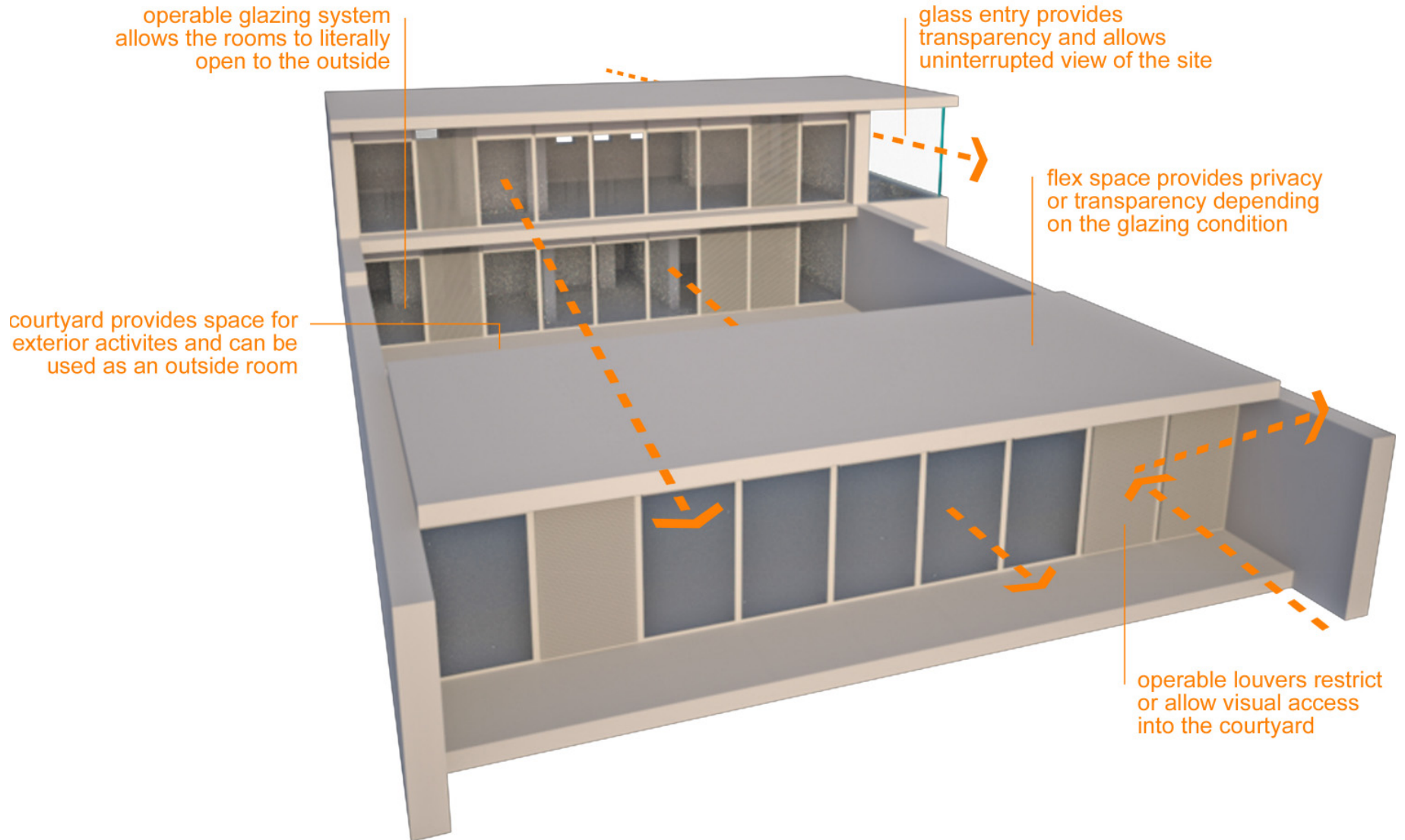

Schematic Rendering

(berm home sun study)

This rendering shows how the sun and views are unobstructed, thus taking full advantage of the floor to ceiling glazing systems.

december 21 @ noon

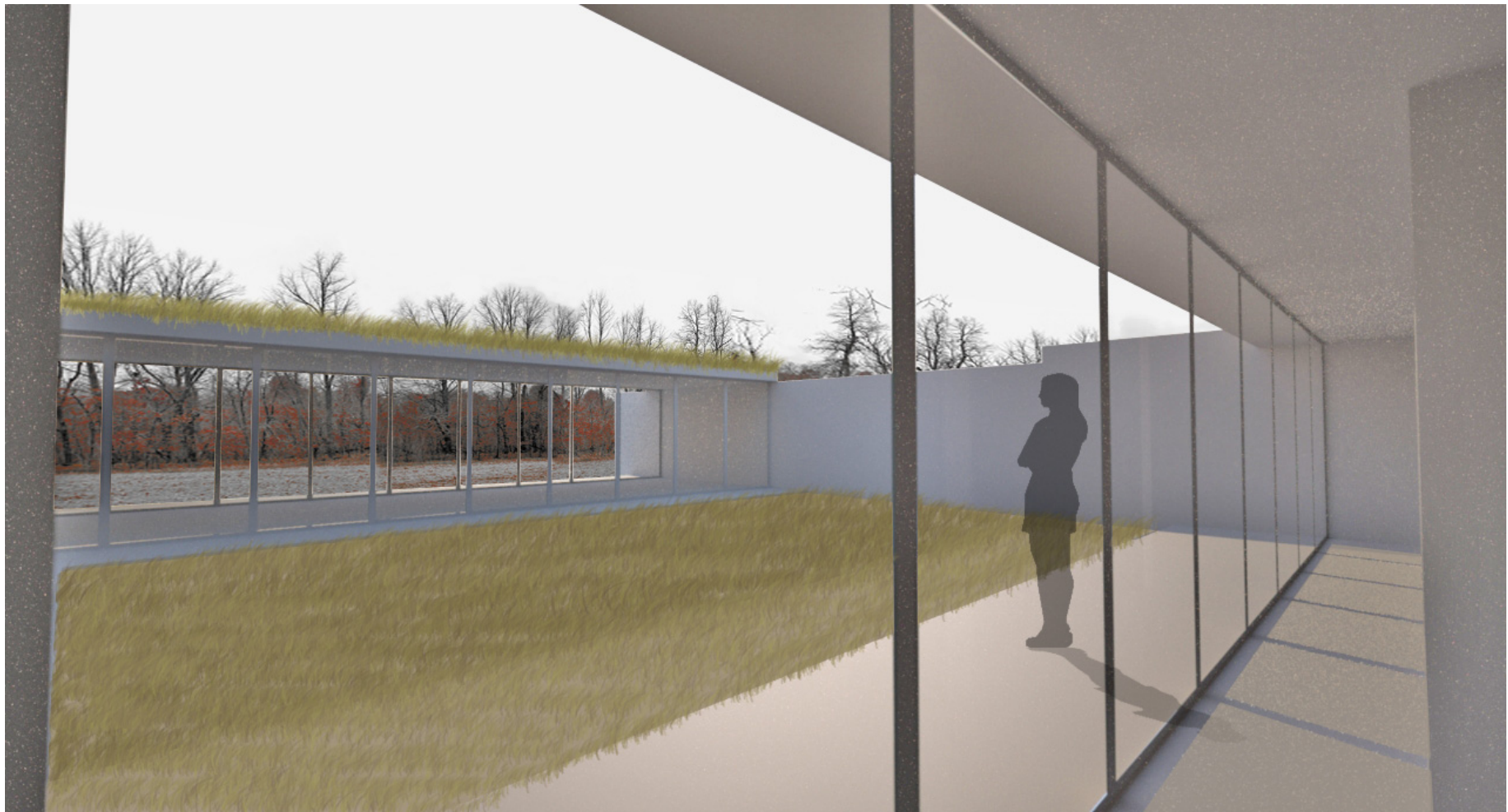

Schematic Rendering

(berm home sun study)

This rendering shows how louvers can be used to obscure not only the sunlight, but also views. The louvers have a three-fold application in that they block unwanted sunlight from entering the space while using the thin film photovoltaic lamination to generate electricity. The third application is to eliminate any unwanted visual access day or night.

december 21 @ noon



Schematic Plan

(berm home)

option a

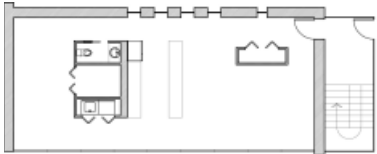

option b

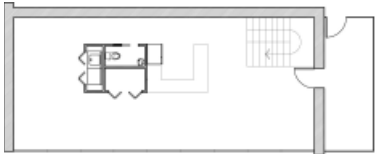

option c



option d

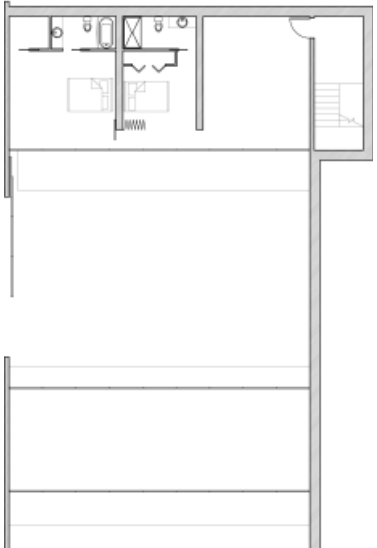
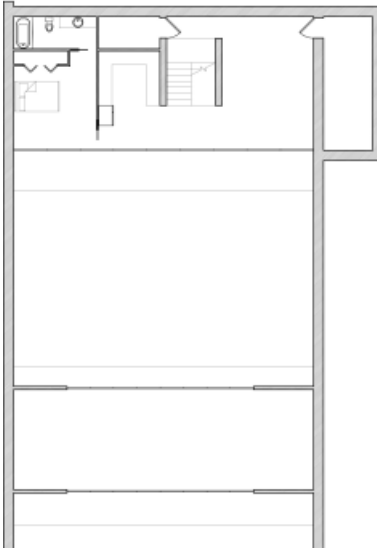
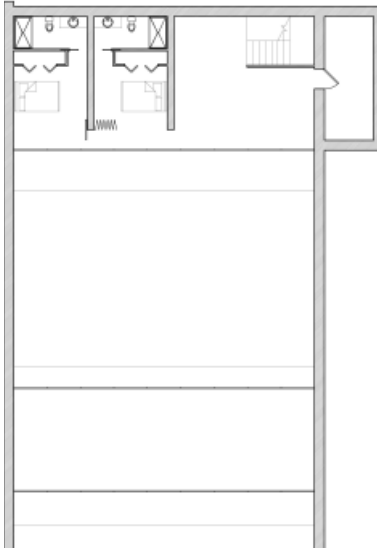
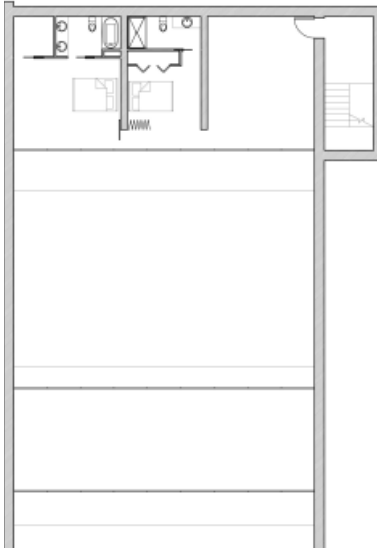
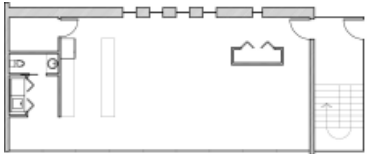

Schematic Section

(berm home)

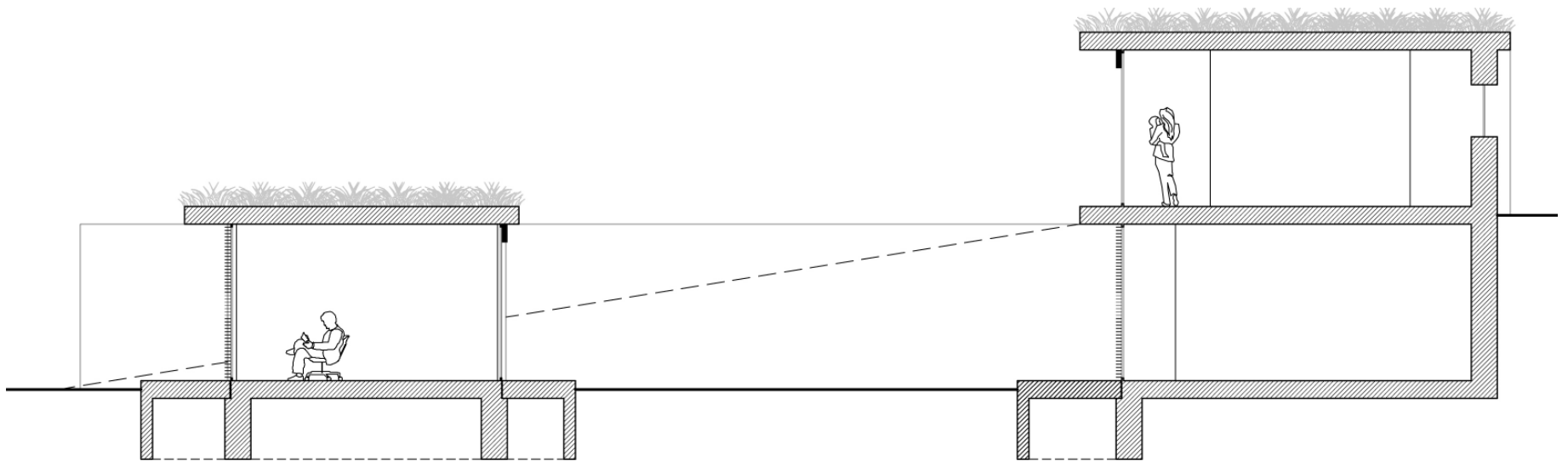

Concept Sketch

(earth concept)

The earth home concept, shown in brown on the site plan is derived from the monol house, and it too incorporates the benefits of the courtyard house.

The idea behind this dwelling is that it shall be located down range on the site from the berm homes, thus allowing a continuation of the landscape when being viewed from above. By incorporating modern aspects of floor to ceiling glass and minimalist style, the earth home concept is hidden from view, while providing a high level of comfort to the occupant.

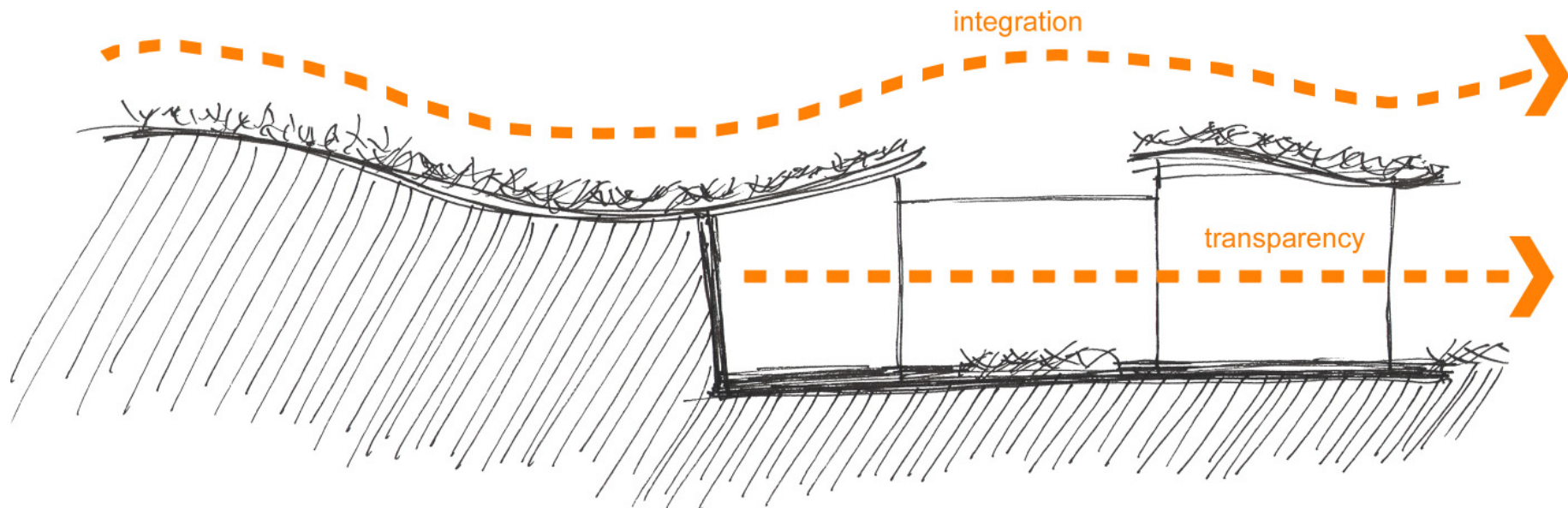
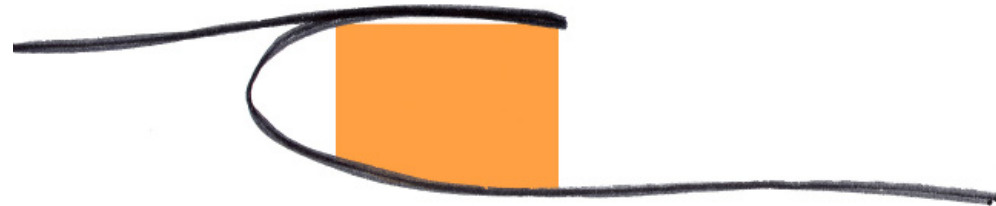

Massing Model

(earth concept)

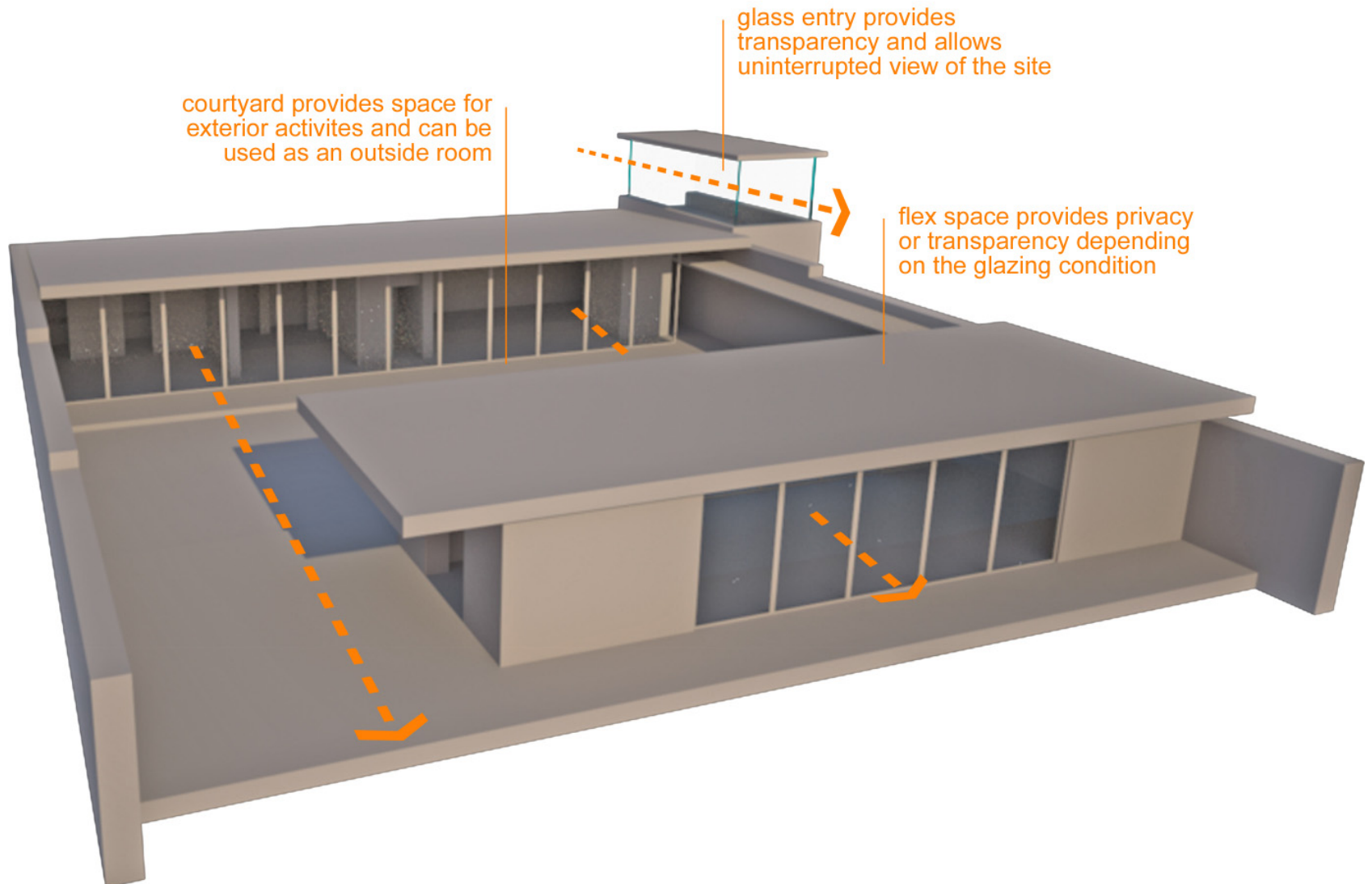

Schematic Rendering

(earth home)

One preconceived notion that many people have about earth homes is that they are dark spaces. The rendering on this page and the next show that good design can alleviate those notions. Natural light floods the space and provides illumination throughout.

december 21 @ noon

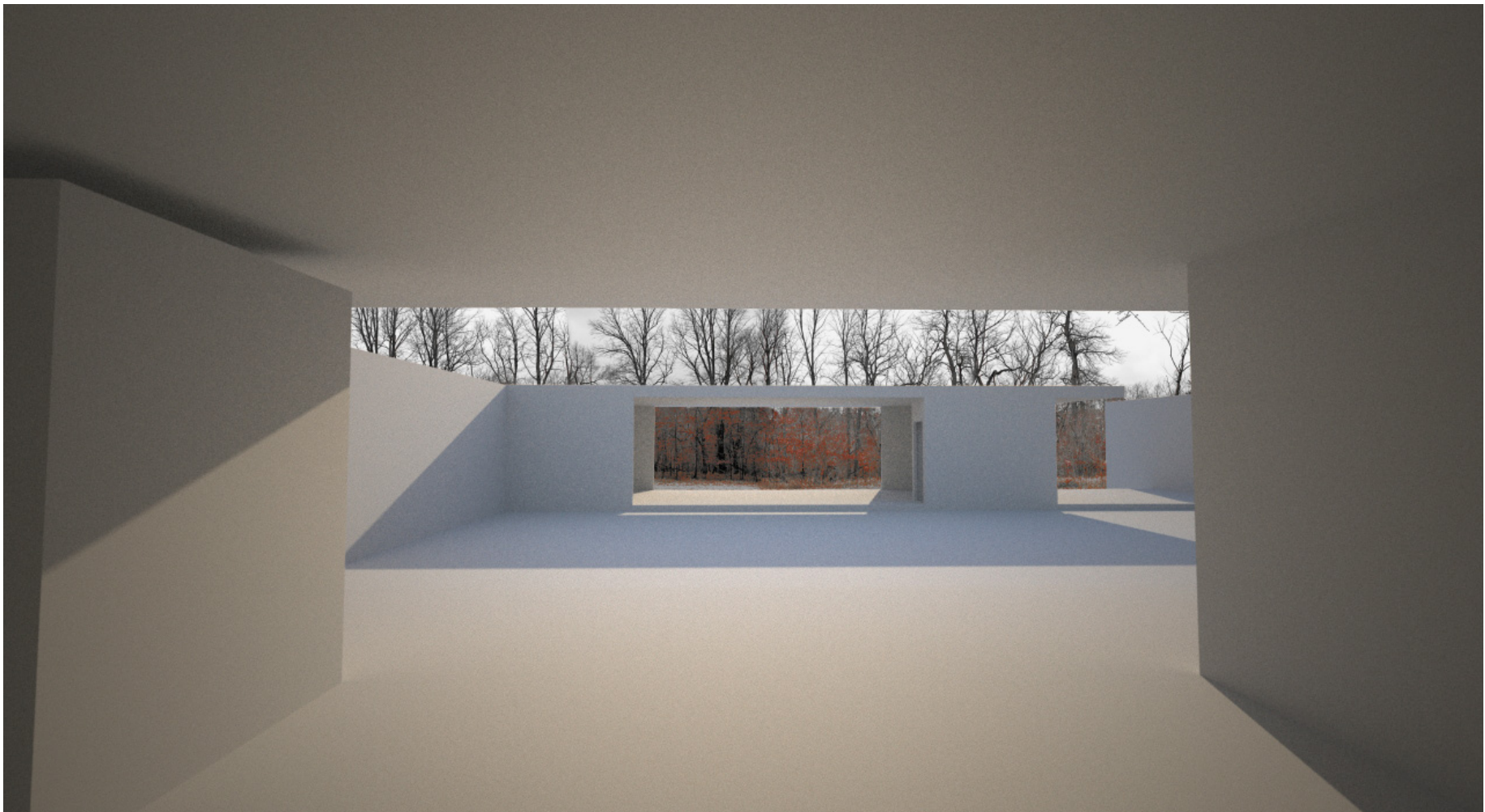

Schematic Rendering

(earth home)

december 21 @ noon

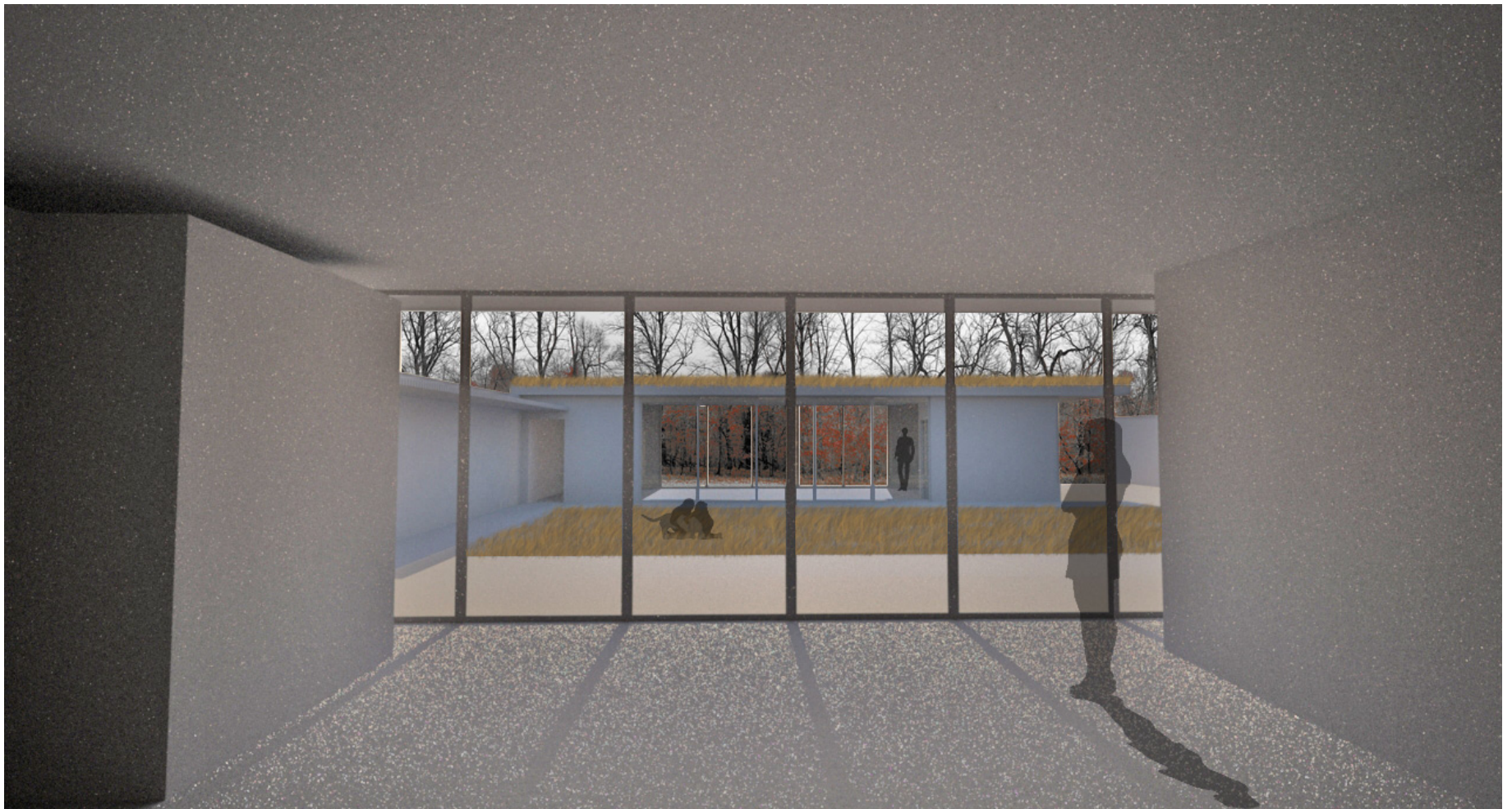

Schematic Plan

(earth home)

option a

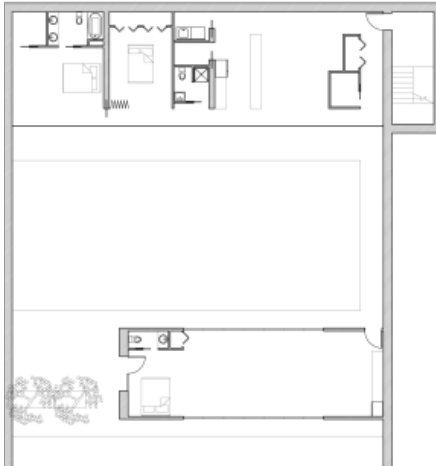

option b

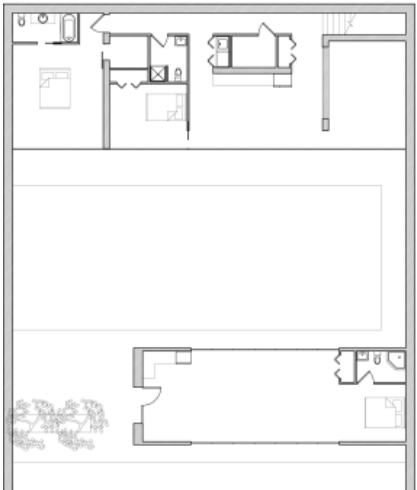
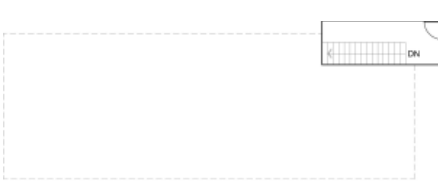

option c

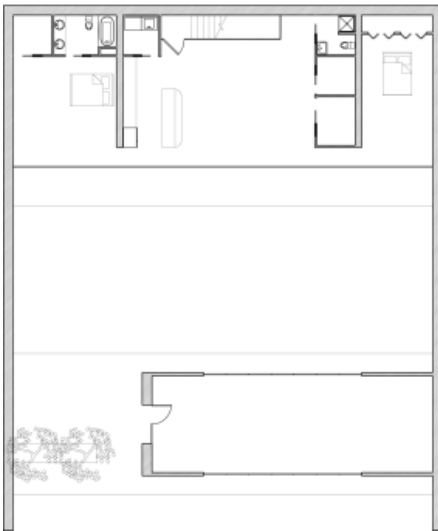

option d



Schematic Section

(earth home)

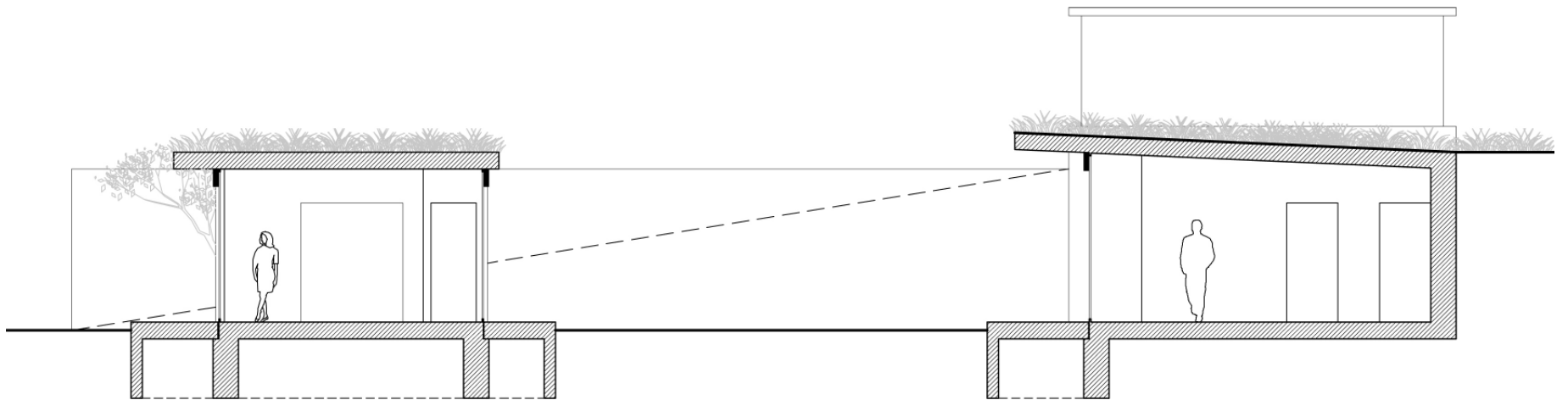

Concept Sketch

(treetop concept)

The final concept is located within the trees near a deep ravine, and is noted in green on the site plan. The treetop concept, incorporates the ideals of the maison domino, but also that of Murcutt's.

The treetop concept will use the natural foliage (deciduous) trees for shading during the summer, but allow for light and solar radiation access during the winter months.

The dwelling is broken up into levels, each becoming more private the higher the occupant ascends.

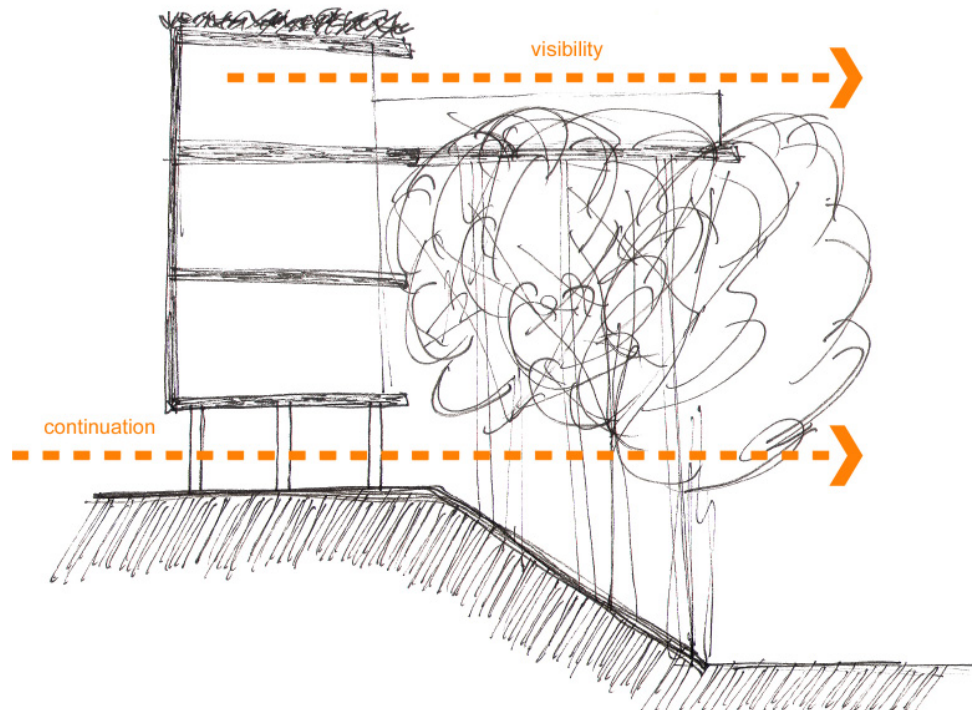
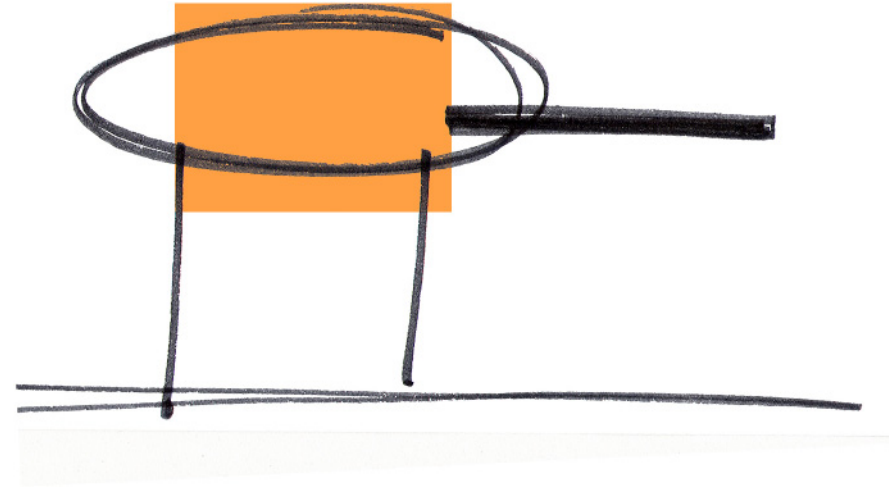

Massing Model

(treetop concept)

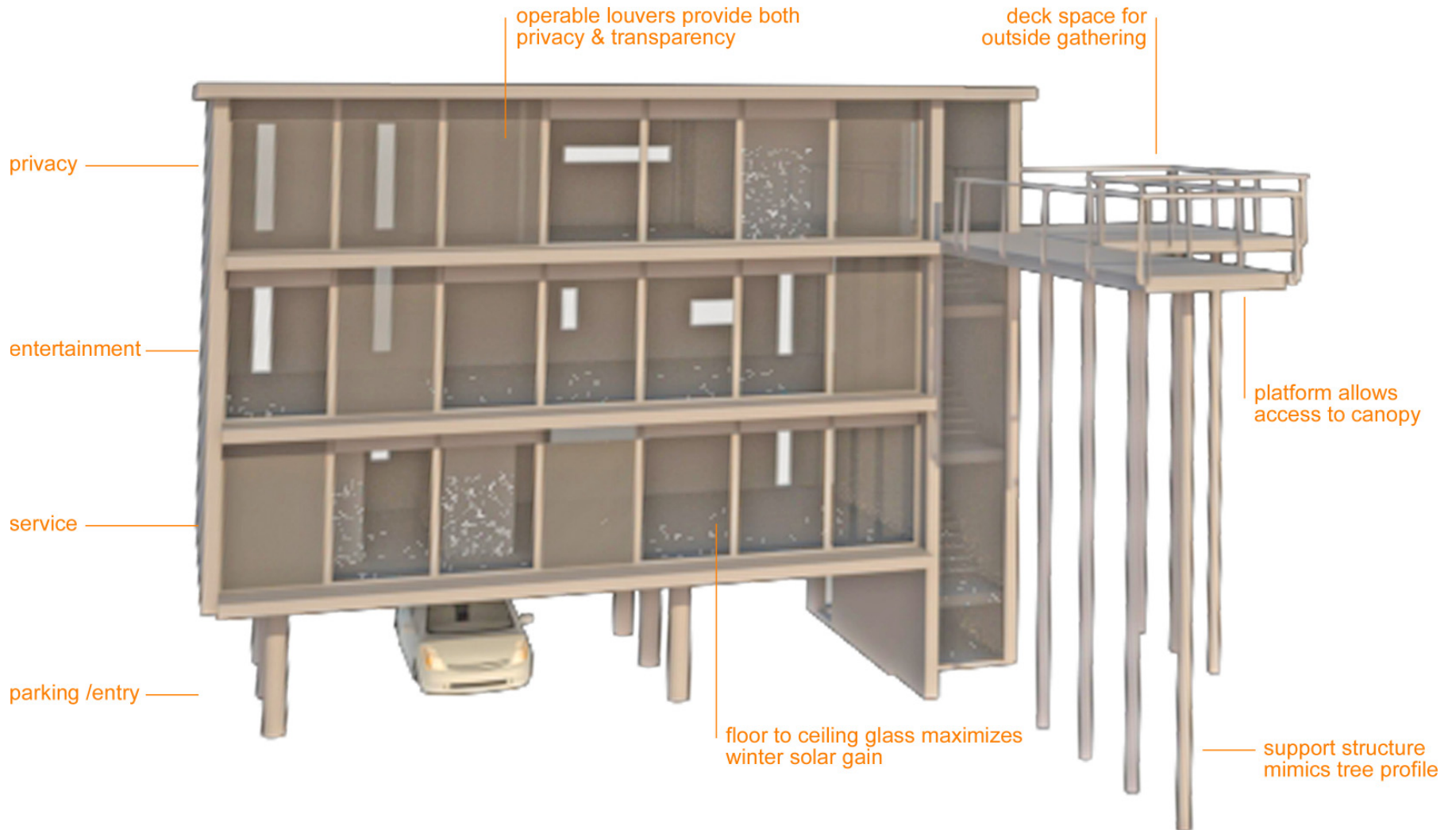

Schematic Plan

(treetop home)

option a



option b

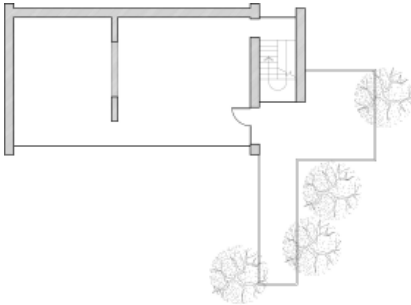

option c

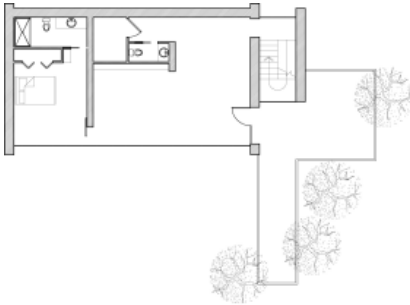

option d

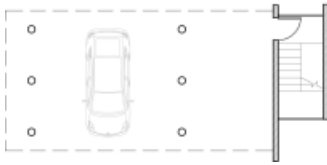
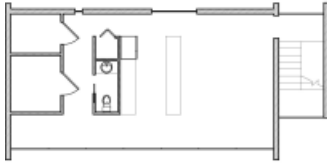
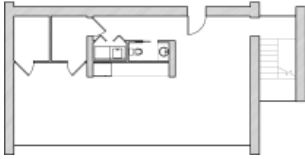
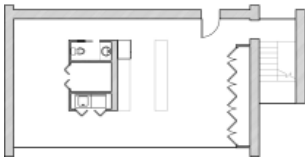
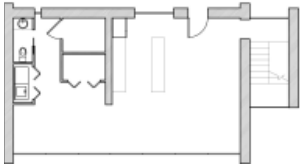
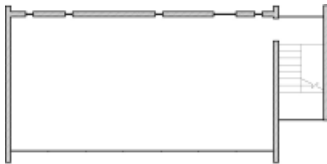
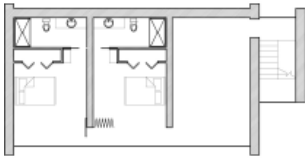
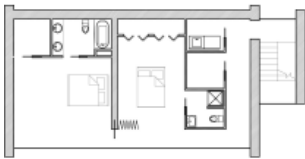
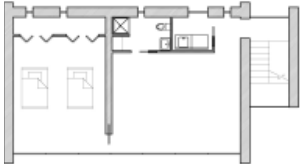

Schematic Section (treetop home)

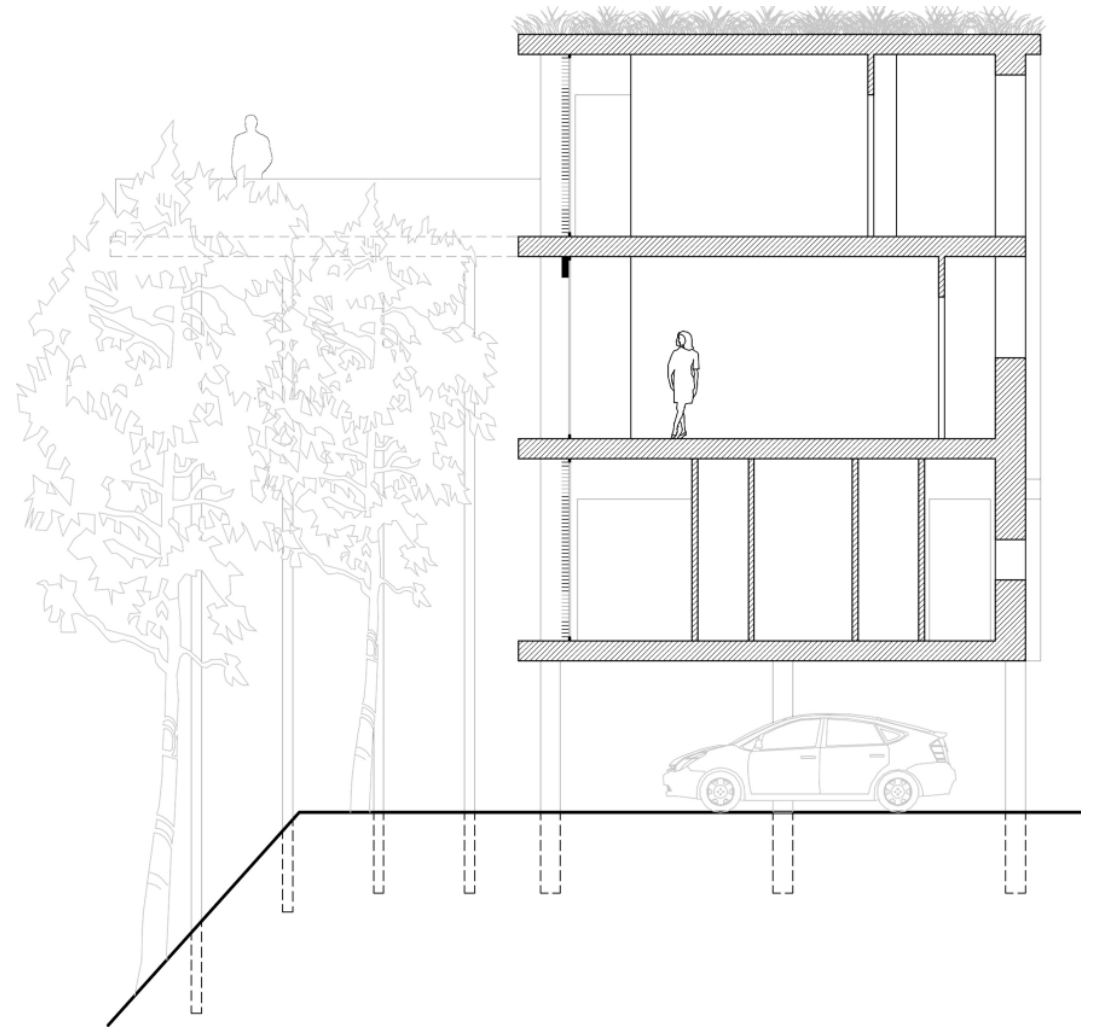

Schematic Rendering

(treetop home)



Schematic Rendering

(treetop home)



Final Design

The last phase of the project is the final design. This stage is the culmination of many hours of research and several critiques. The evolution of the project has gone from initially investigating the issues at hand to implementing intelligent, intuitive, responsible design solutions into each aspect of each dwelling.

Detailed plans, sections and renderings illustrate the manifestation of knowledge gained throughout the year, as well the advice taken from various critics.

Three final dwelling types were designed for specific areas on the site. A bermed home, earth home, and tree-top home. Each offering unique differences in location and design, yet all performing at a 90% passive level year round. Although none of these designs can be proven as 100% passive, the result is felt to be much more responsive, respectful and appropriate than the typical alternative.

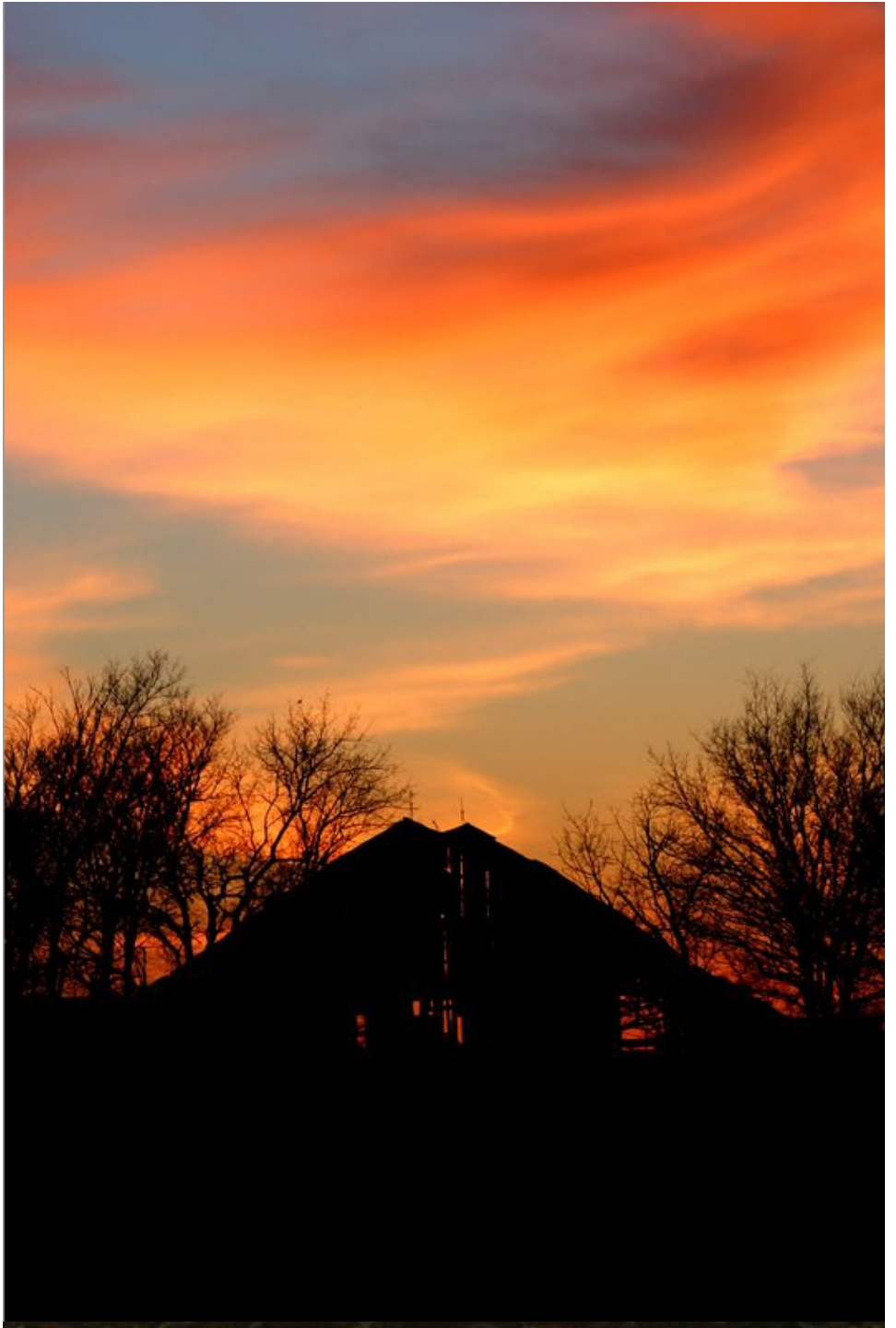

Site Plan

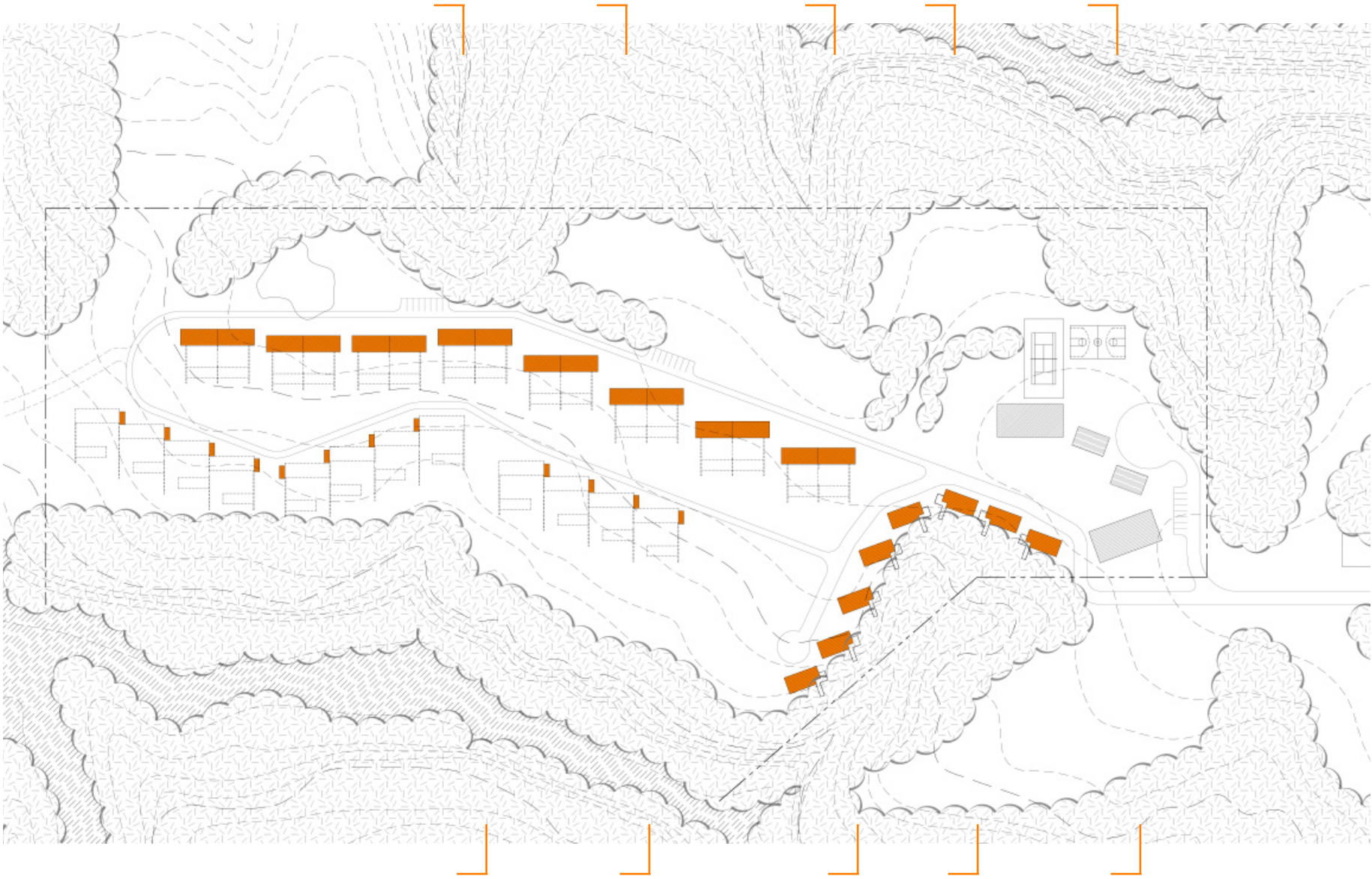

Site Sections



Berm Floorplan

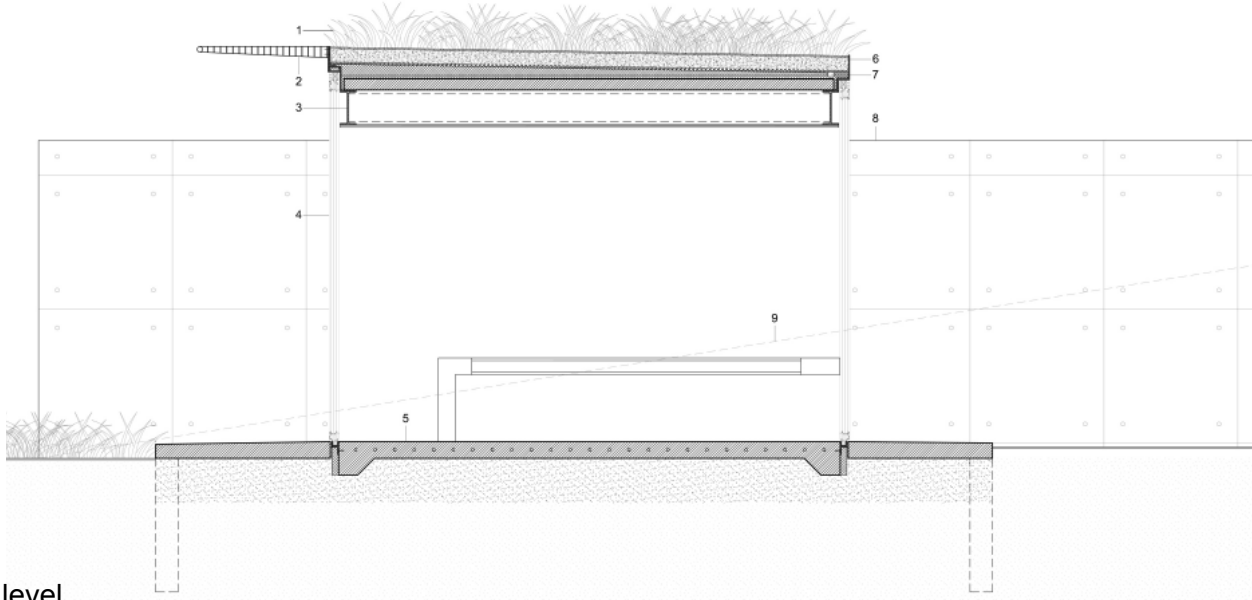
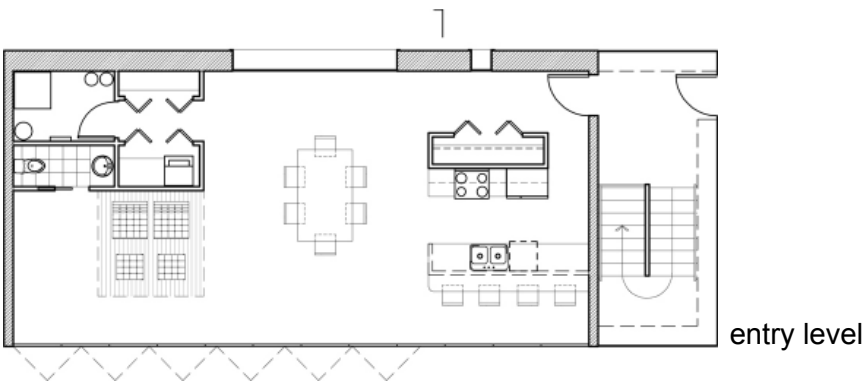
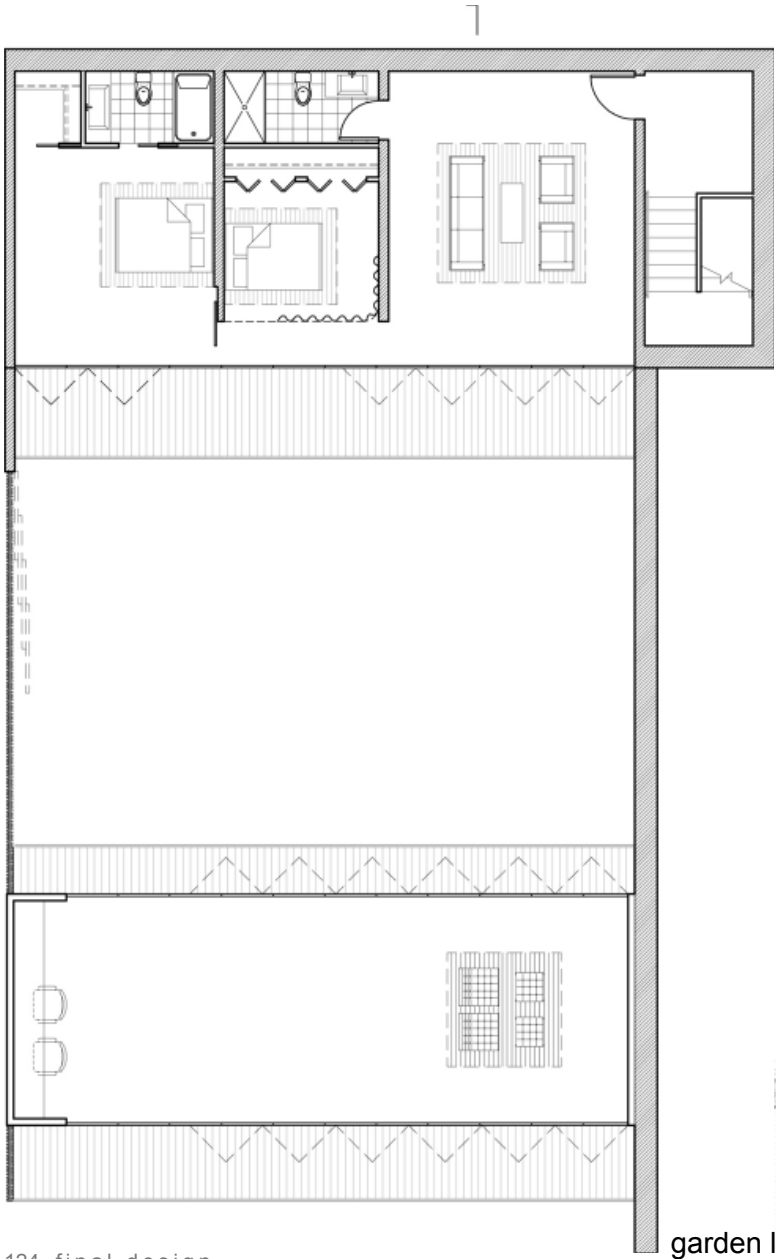

Berm Section

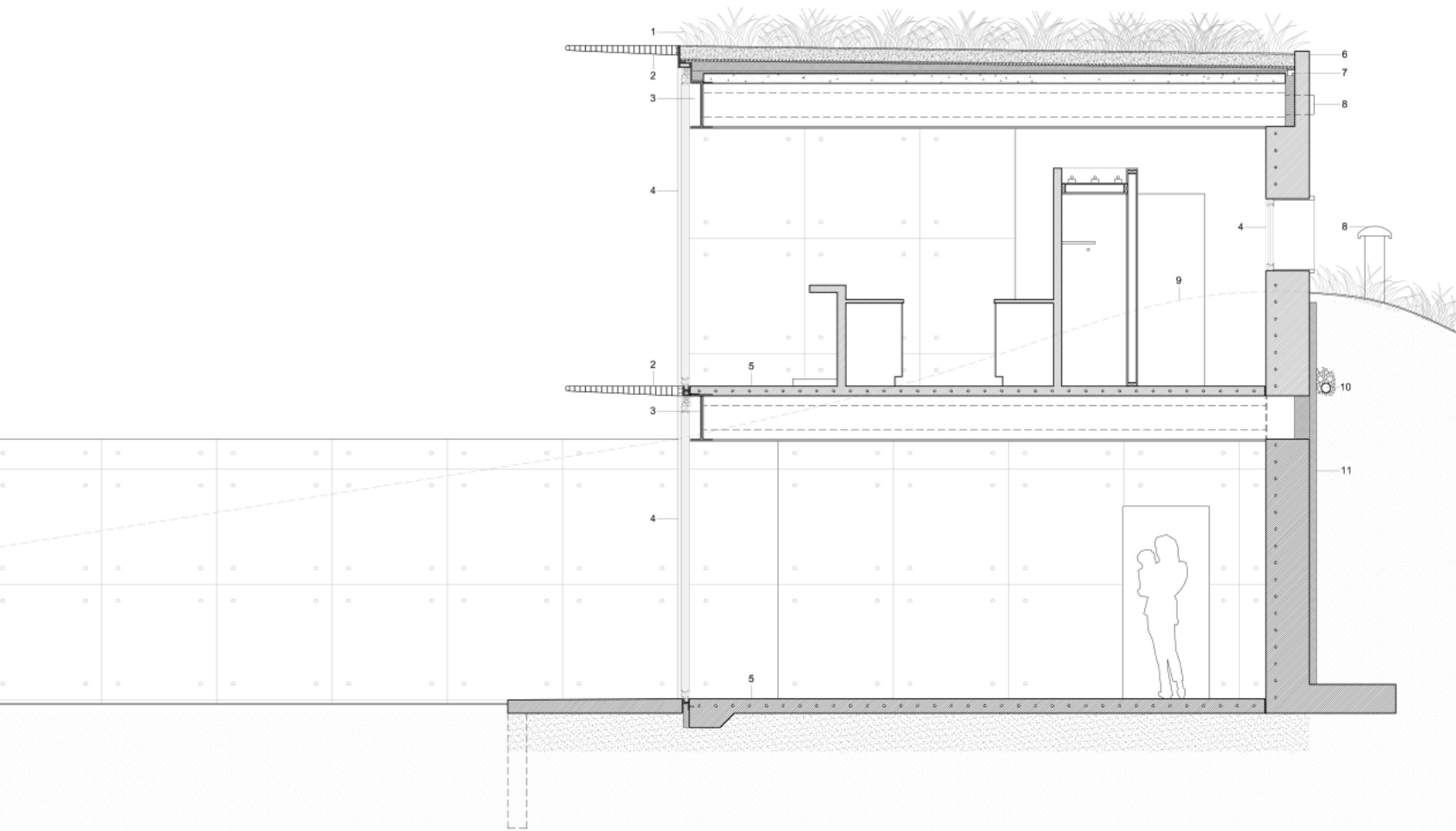

- 1 *green roof system:*
 native vegetation
 growing medium
 drainage, aeration, and water storage system
 45 mil. epdm membrane
 rigid insulation
 vacuum insulation panel
 6 mil. vapor barrier
 ultra-light concrete roof slab
 lighting/ventilation cavity
 $\frac{1}{2}$ " horiz. channel furring
 $\frac{1}{2}$ " wood ceiling plank
- 2 *louver system:*
 aluminum louver system
 flashed steel angle
 cont. horizontal steel tubing
- 3 steel "I" beam
- 4 triple glazed, operable window system
- 5 polished concrete slab (thickened at ends)
 rigid insulation (at ends)
 hydronic heating system
 foam-glass insulation
 earth fill
- 6 parapet wall ext. (flushed)
- 7 roof drain
- 8 ventilation intake/exhaust
- 9 slope of earth (beyond)
- 10 drainage tile
- 11 *concrete wall system:*
 6 mil. waterproof membrane
 rigid insulation
 ultra-light concrete
 hydronic heating system

Physical Model

(1/4" scale)



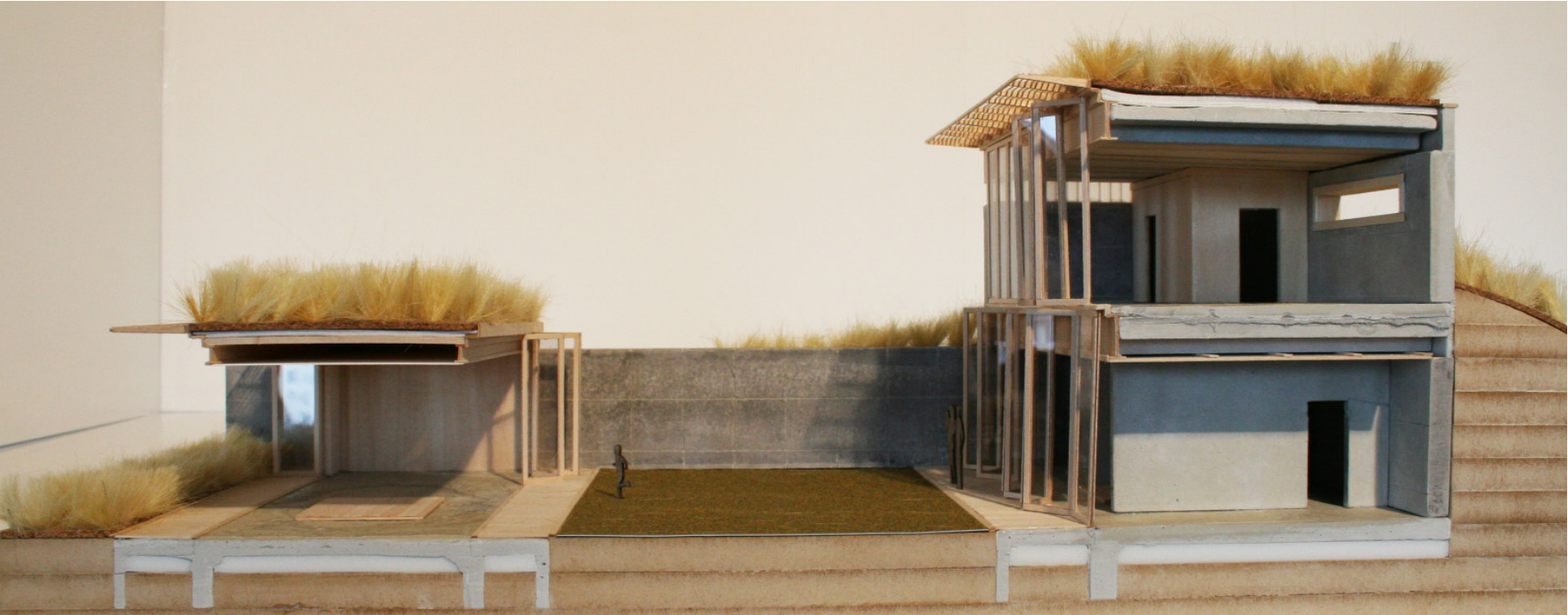

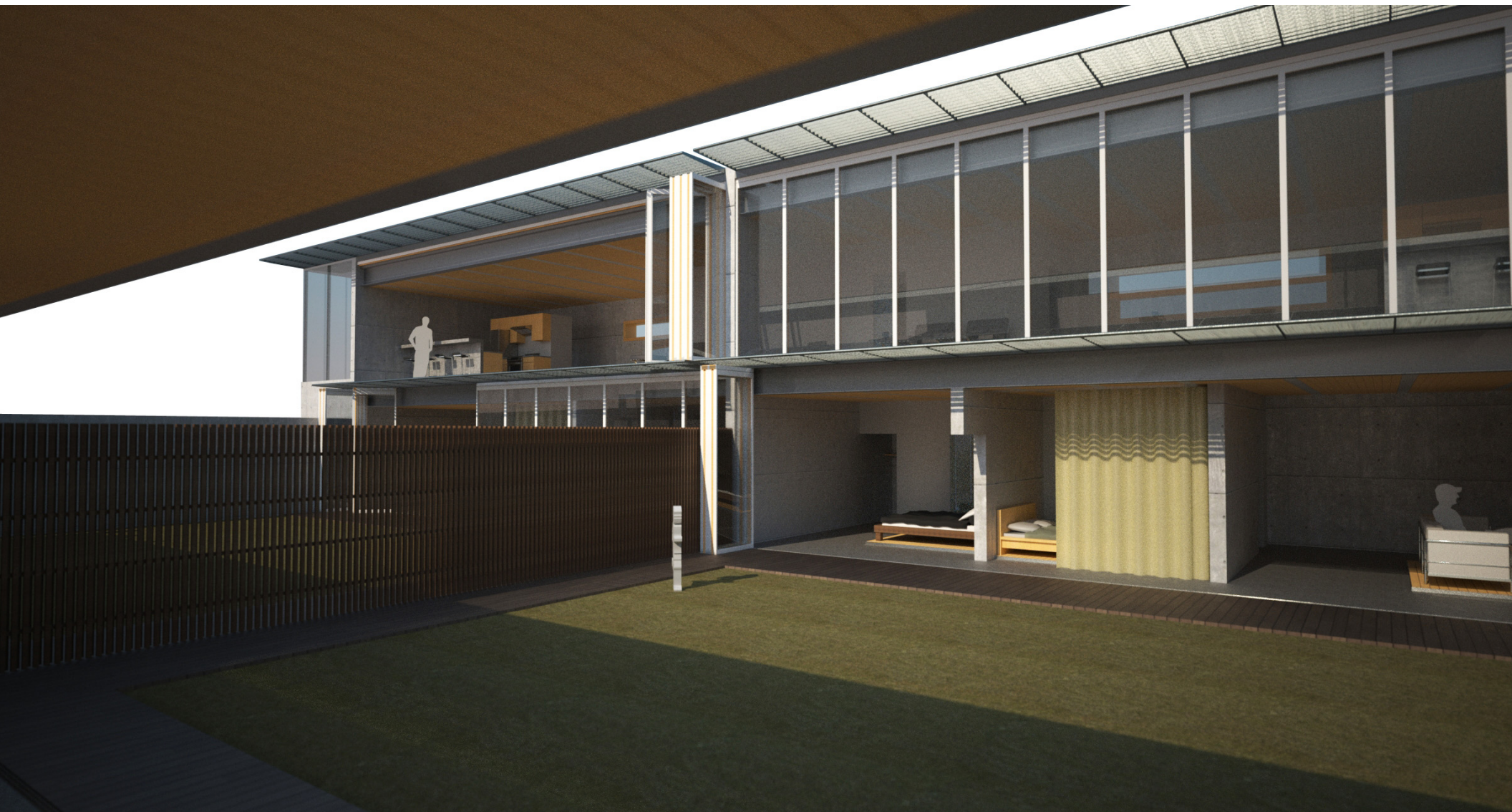

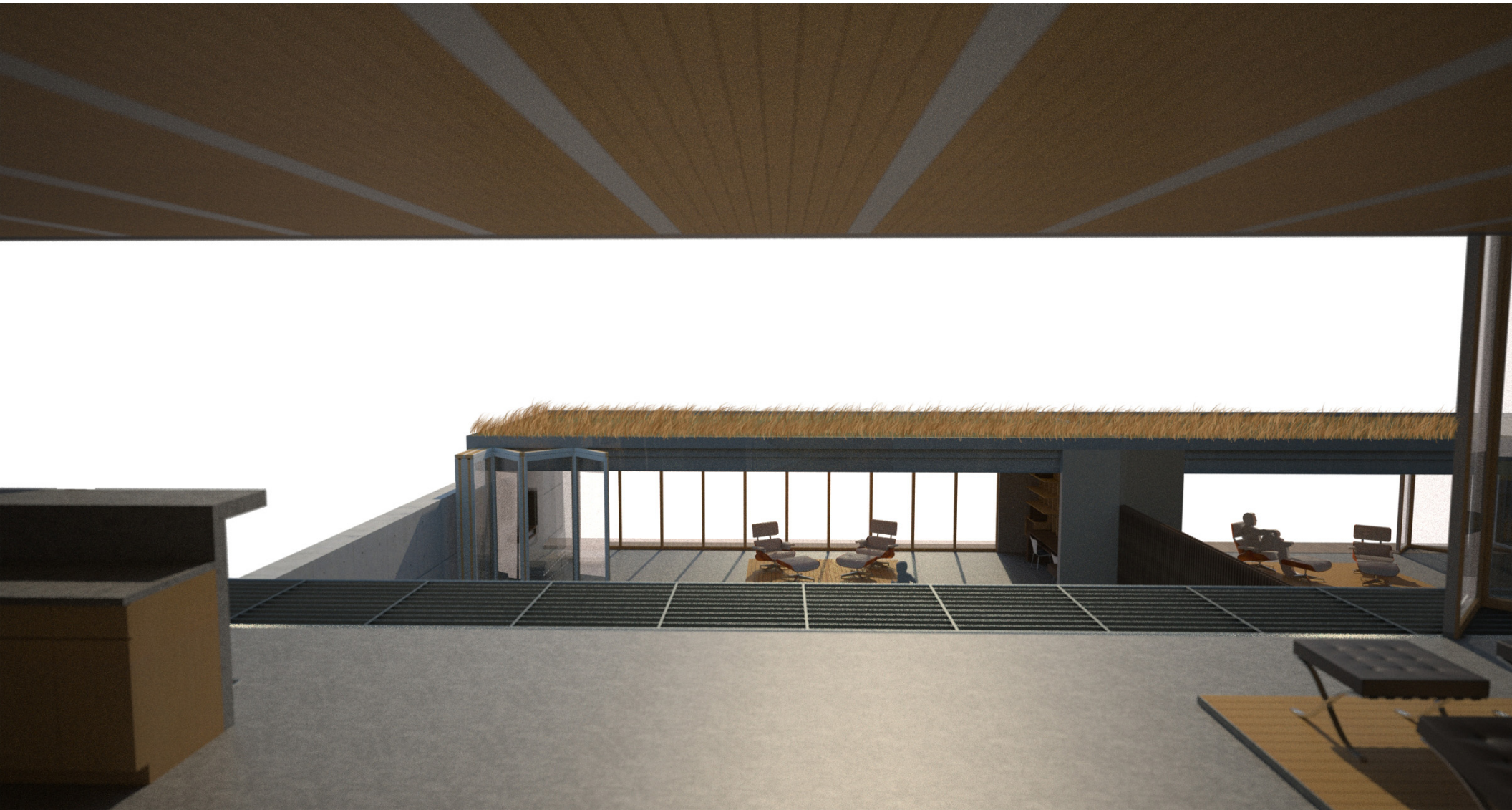

Earth Floorplan



entry level

garden level

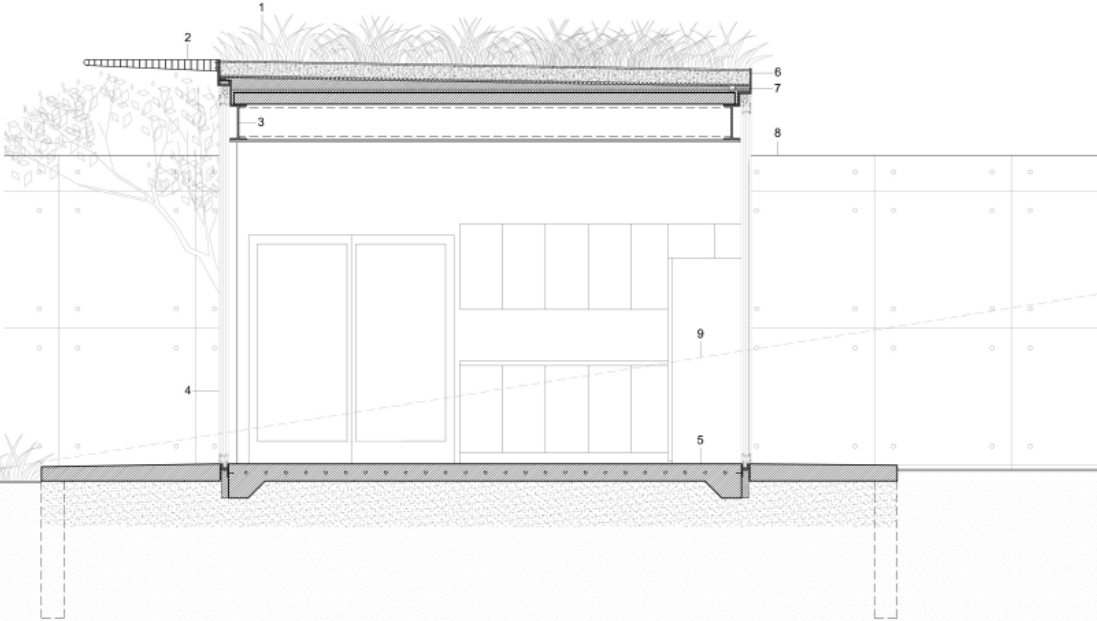

Earth Section

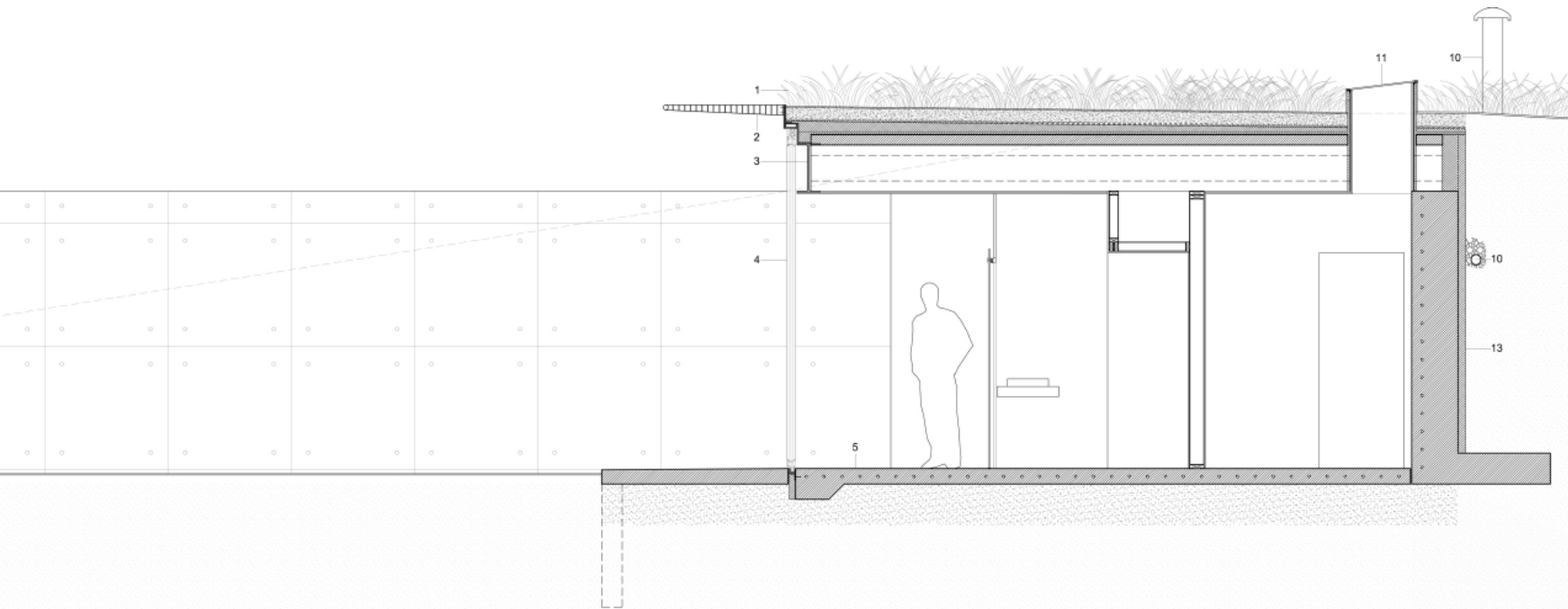

- 1 *green roof system:*
 native vegetation
 growing medium
 drainage, aeration, and water storage system
 45 mil. epdm membrane
 rigid insulation
 vacuum insulation panel
 6 mil. vapor barrier
 ultra-light concrete roof slab
 lighting/ventilation cavity
 $\frac{1}{2}$ " horiz. channel furring
 $\frac{1}{2}$ " wood ceiling plank
- 2 *louver system:*
 aluminum louver system
 flashed steel angle
 cont. horizontal steel tubing
- 3 steel "I" beam
- 4 triple glazed, operable window system
- 5 polished concrete slab (thickened at ends)
 rigid insulation (at ends)
 hydronic heating system
 foam-glass insulation
 earth fill
- 6 steel angle retainer (flashed)
- 7 roof drain
- 8 retaining wall (beyond)
- 9 slope of earth (beyond)
- 10 ventilation intake/exhaust
- 11 *skylight system:*
 insulated glazing panel
 6 mil. vapor barrier
 vacuum insulation panel
 steel liner
 $\frac{1}{2}$ " wood ceiling plank
- 12 drainage tile
- 13 *concrete wall system:*
 6 mil. waterproof membrane
 rigid insulation
 ultra-light concrete
 hydronic heating system

Physical Model

(1/4" scale)



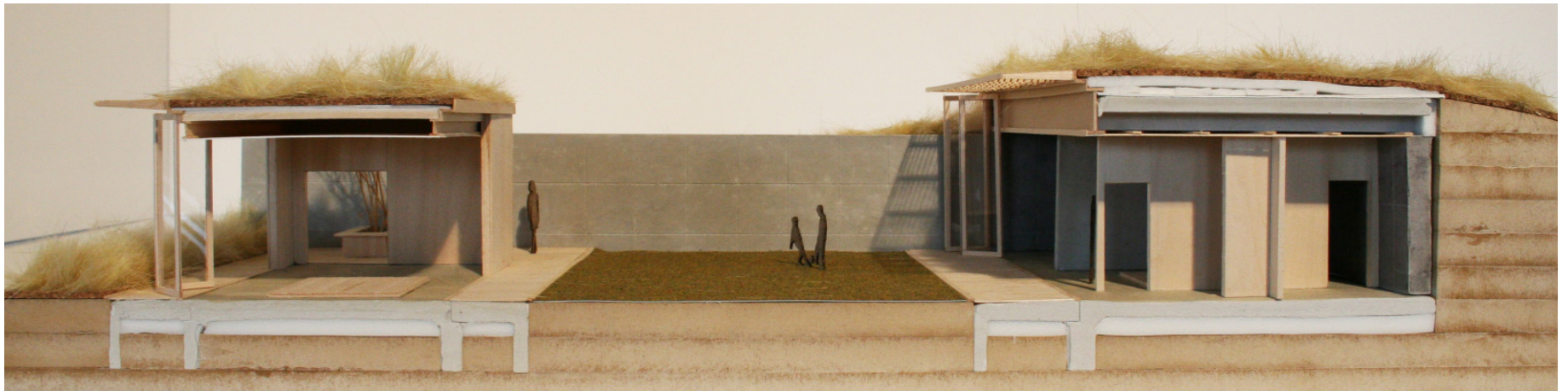

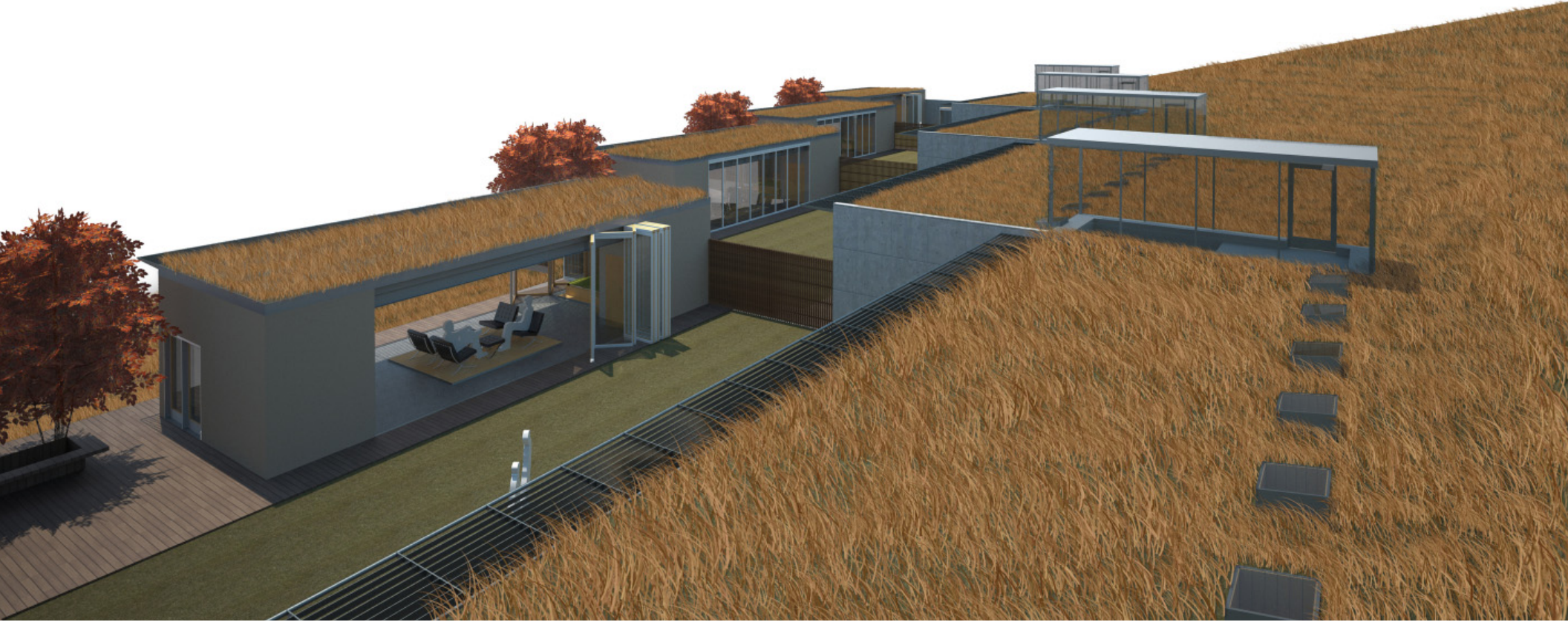

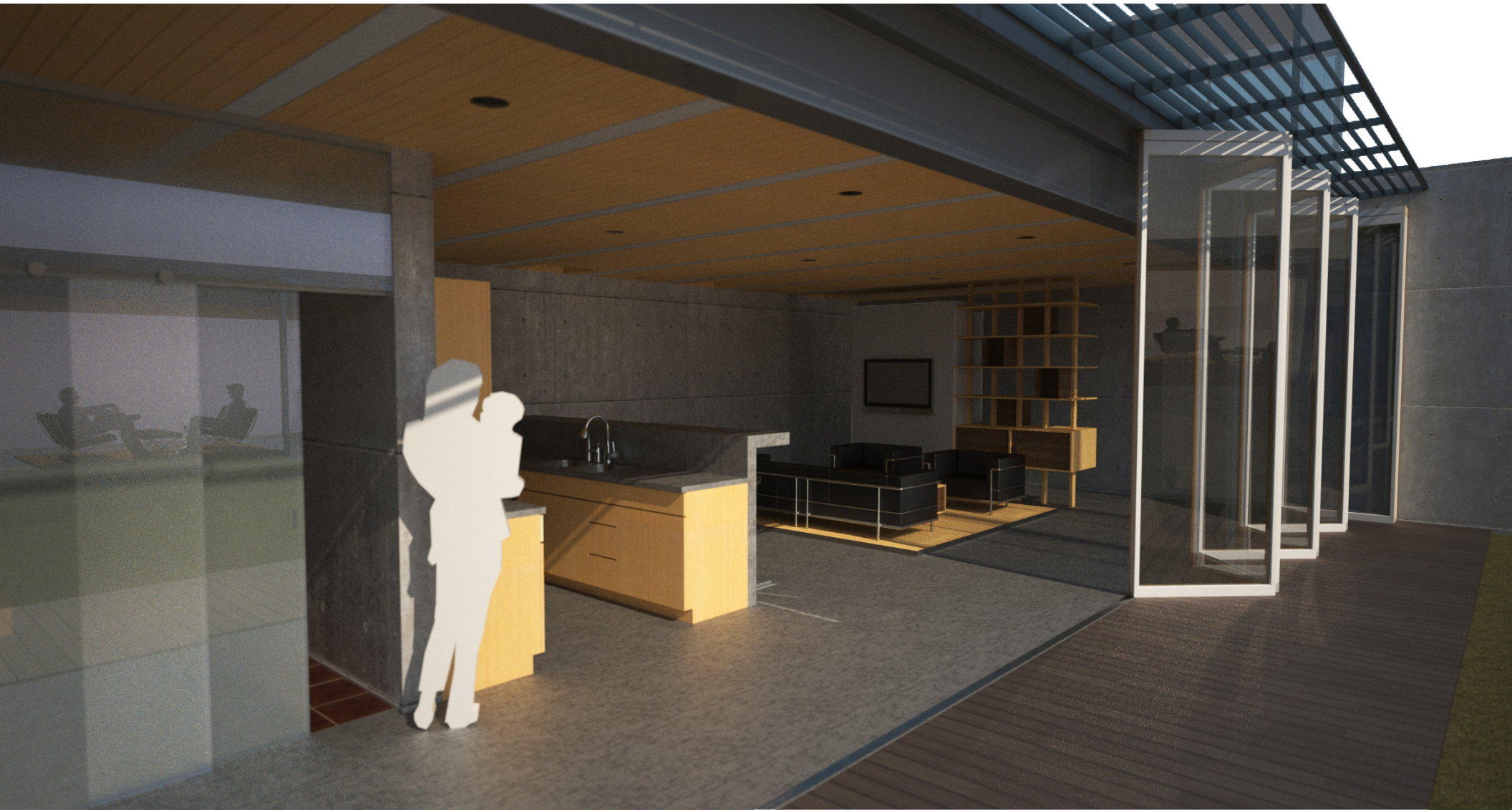

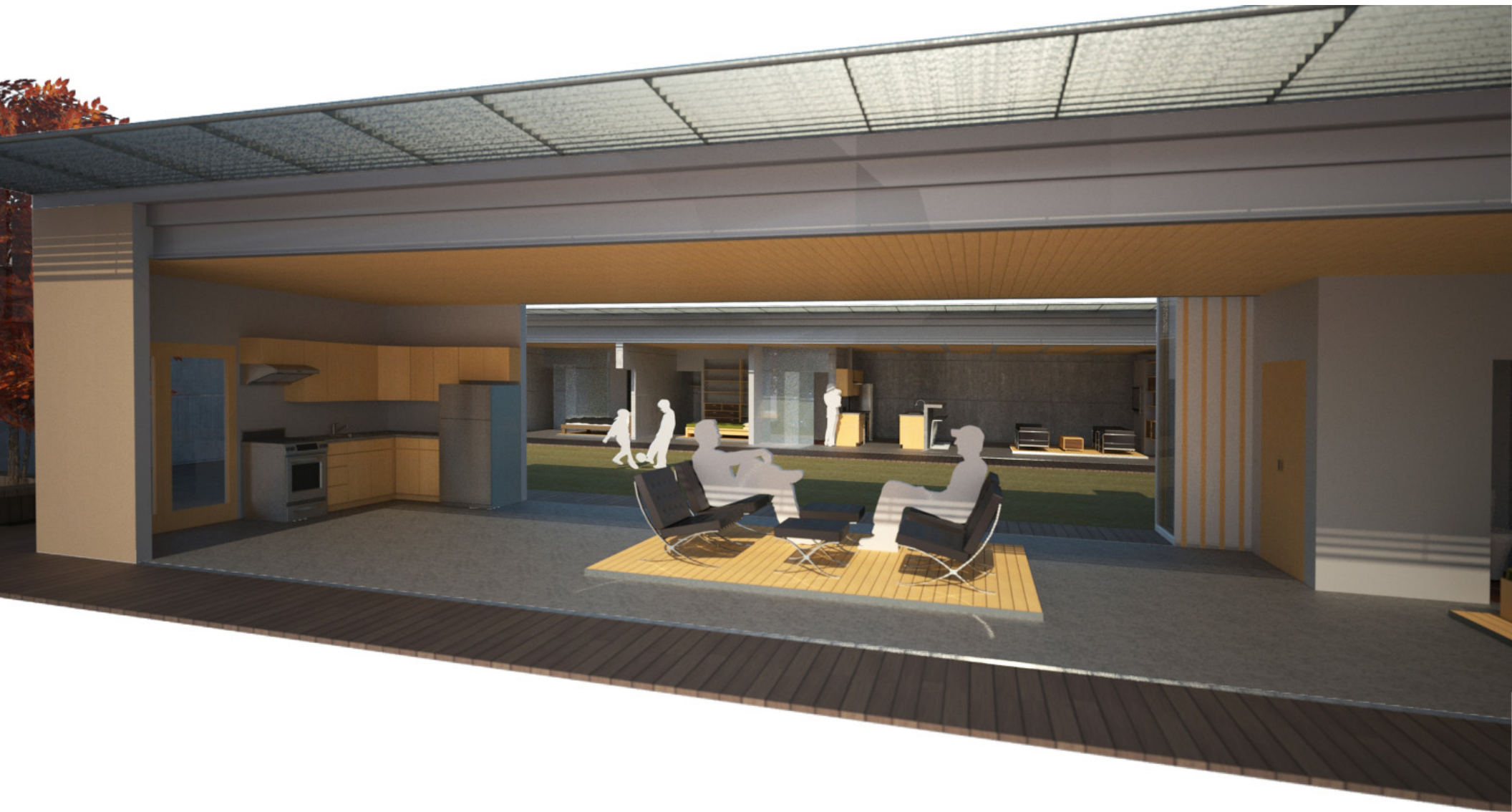

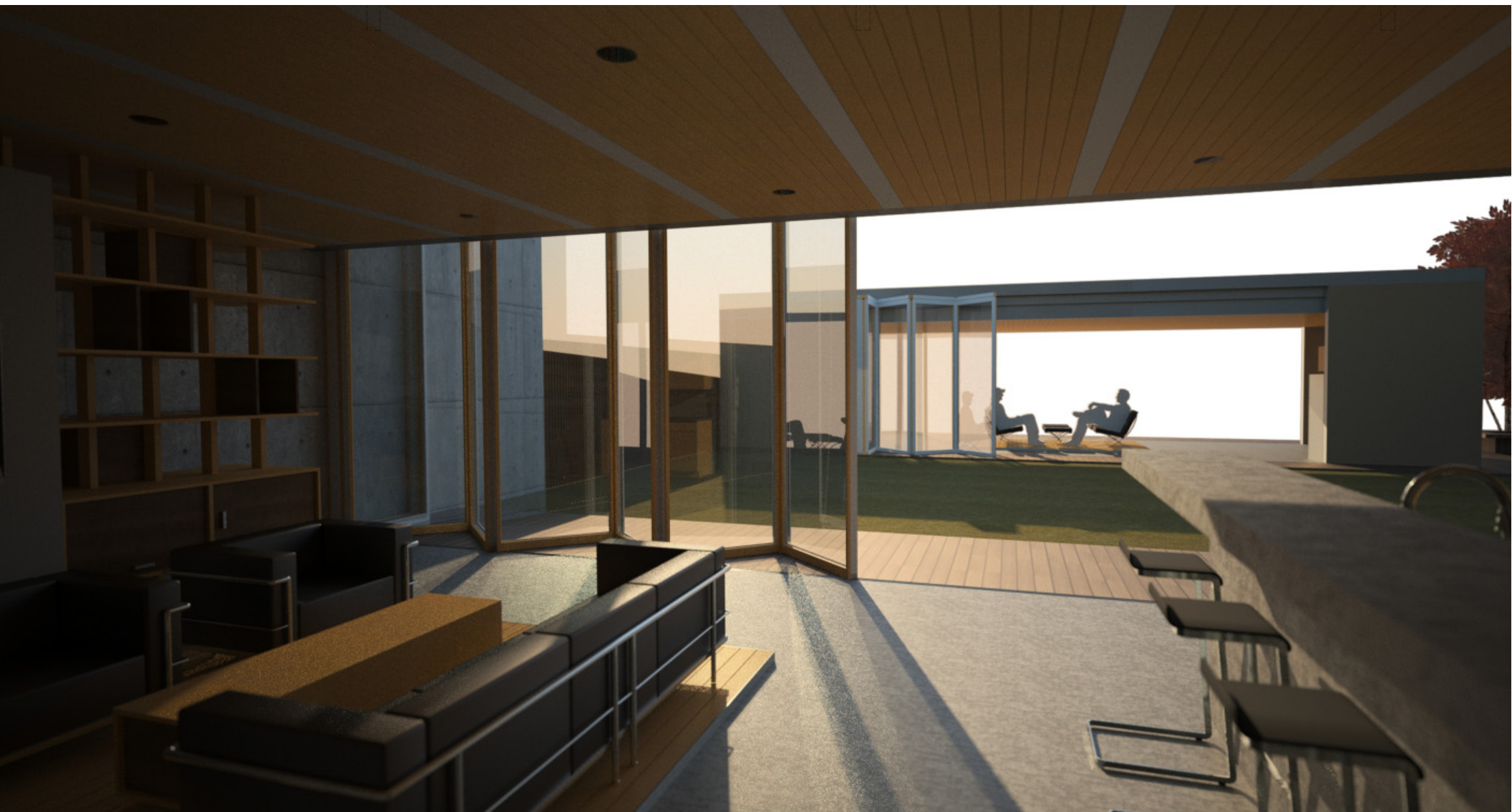





Treetop Floorplans

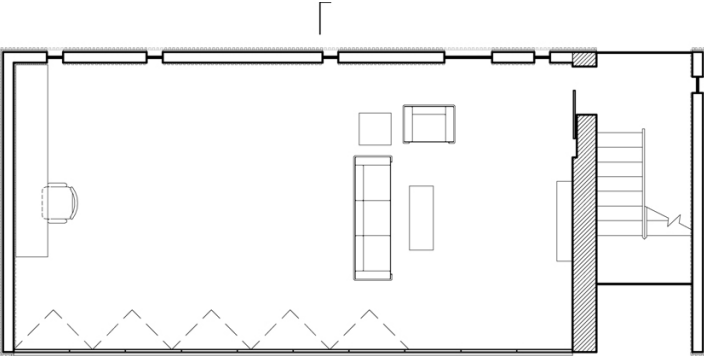

third level

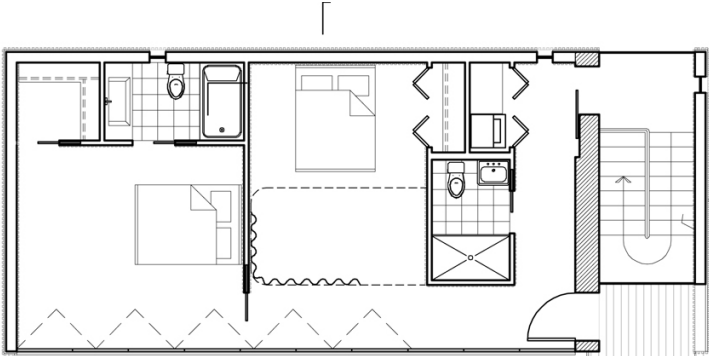

fourth level

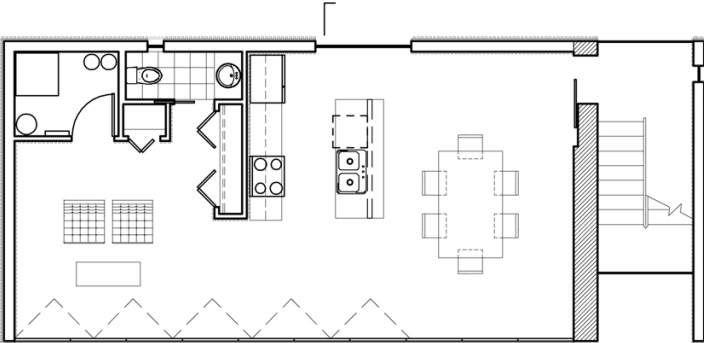

second level

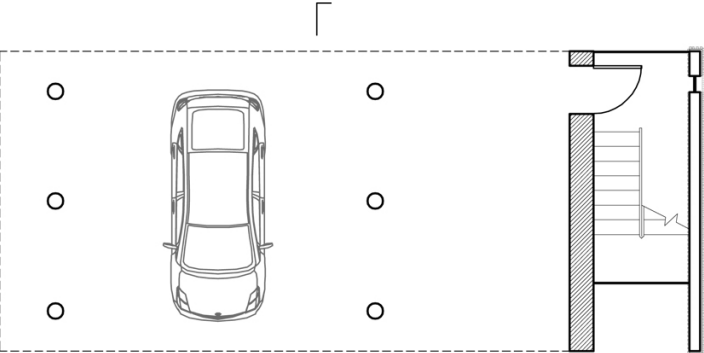

entry level

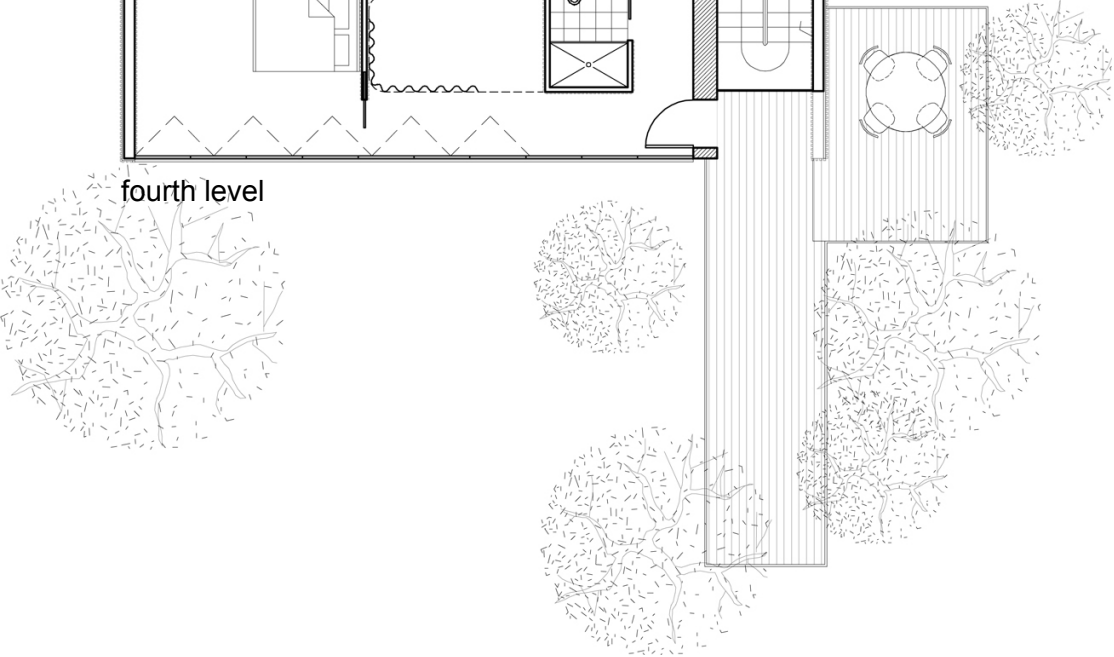

Treetop Section

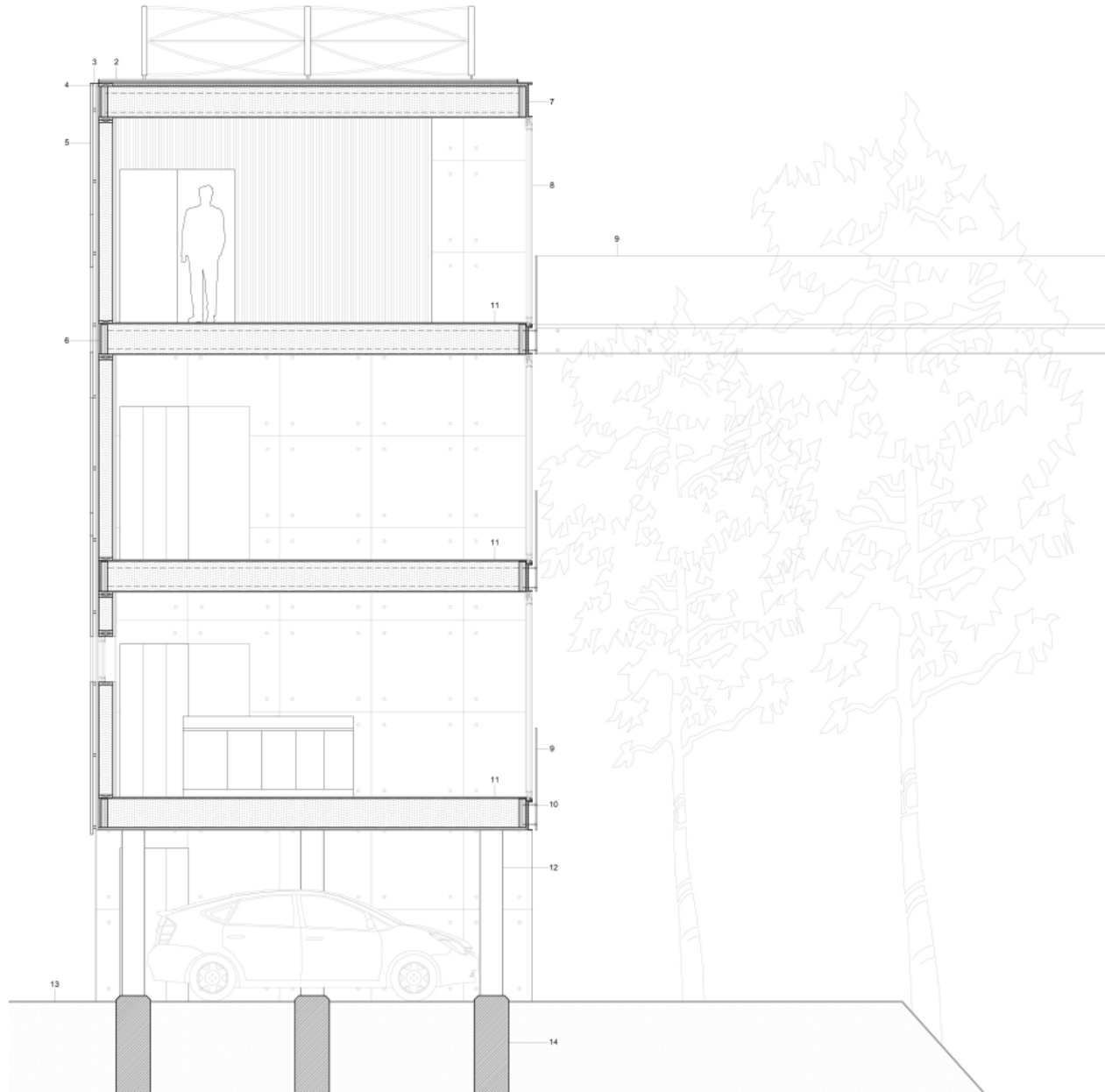

- 1 helical wind turbine
- 2 roof system:
 - $\frac{3}{4}$ " sheathing (sealed)
 - $\frac{1}{2}$ " marine grade o.s.b.
 - 45 mil. epdm membrane
 - vacuum insulation panel (top & ends)
 - 6 mil. vapor barrier
 - TGI roof truss
 - dry-pack cellulose insulation
 - $\frac{1}{2}$ " furring
 - $\frac{1}{2}$ " wood ceiling plank
- 3 steel angle (flushed)
- 4 2x8 stop
- 5 exterior wall system:
 - 2x2 heat treated wood slats (vertical)
 - aluminum runner (horizontal)
 - $\frac{1}{2}$ " marine grade o.s.b.
 - 6mil. vapor barrier
 - 2x8 stud wall
 - blown cellulose insulation
 - $\frac{1}{2}$ " sheathing
 - $\frac{3}{4}$ " furring
 - 2x2 heat treated wood slats (vertical)
- 6 glu-lam beam (at ends)
- 7 steel "c" channel
- 8 triple glazed, operable window system
- 9 $\frac{3}{4}$ " glass railing
- 10 anchor bolts
- 11 floor system:
 - $\frac{1}{2}$ " solid wood floor
 - $\frac{1}{2}$ " kerf-cut o.s.b subfloor
 - TGI floor truss
 - lighting/ventilation cavity
 - dry-pack cellulose insulation
 - $\frac{1}{2}$ " furring
 - $\frac{3}{2}$ " wood ceiling plank
- 12 steel column
- 13 grasscrete cellular paving system
- 14 concrete base & footing

Physical Model

(1/4" scale)





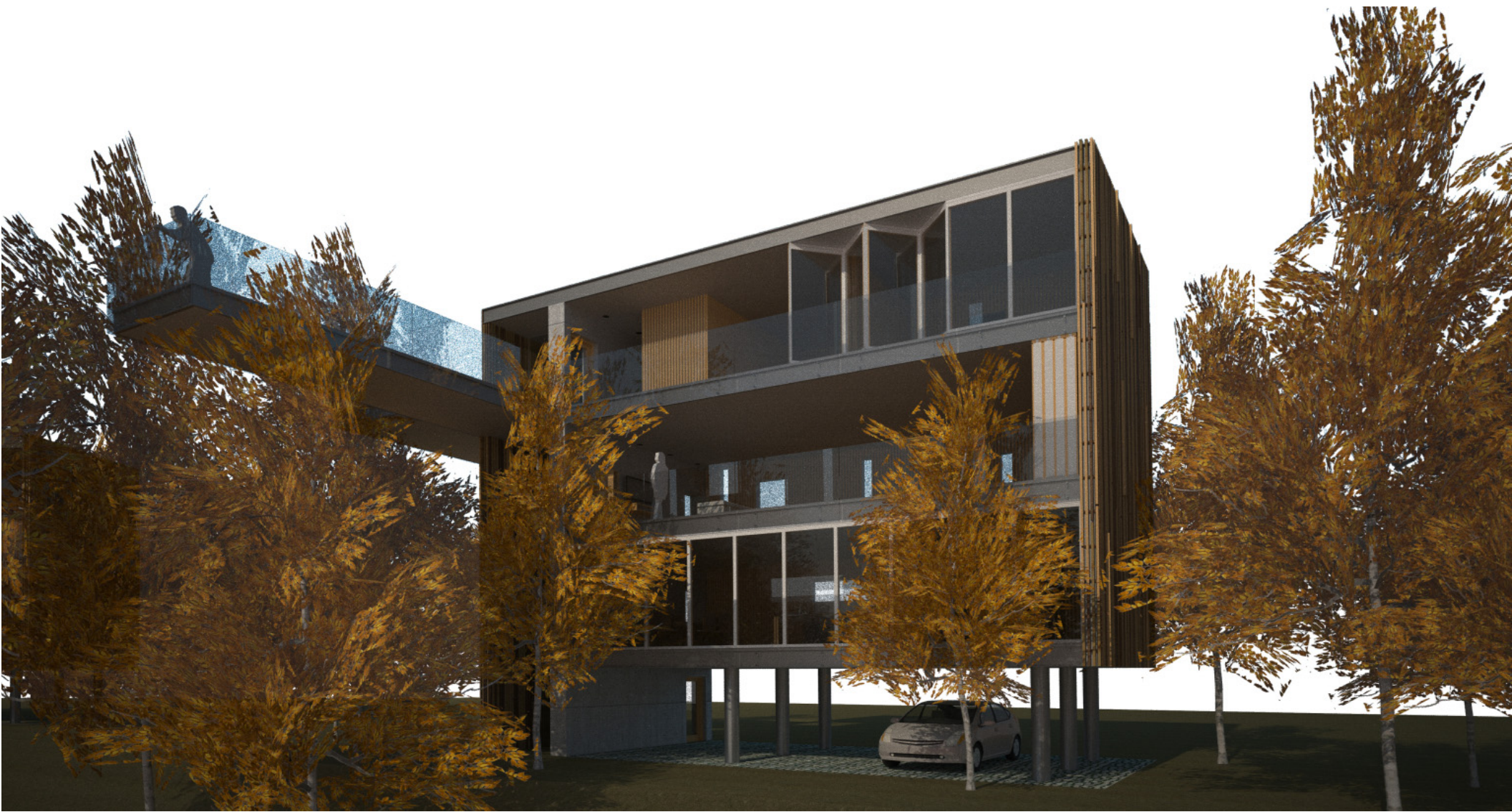

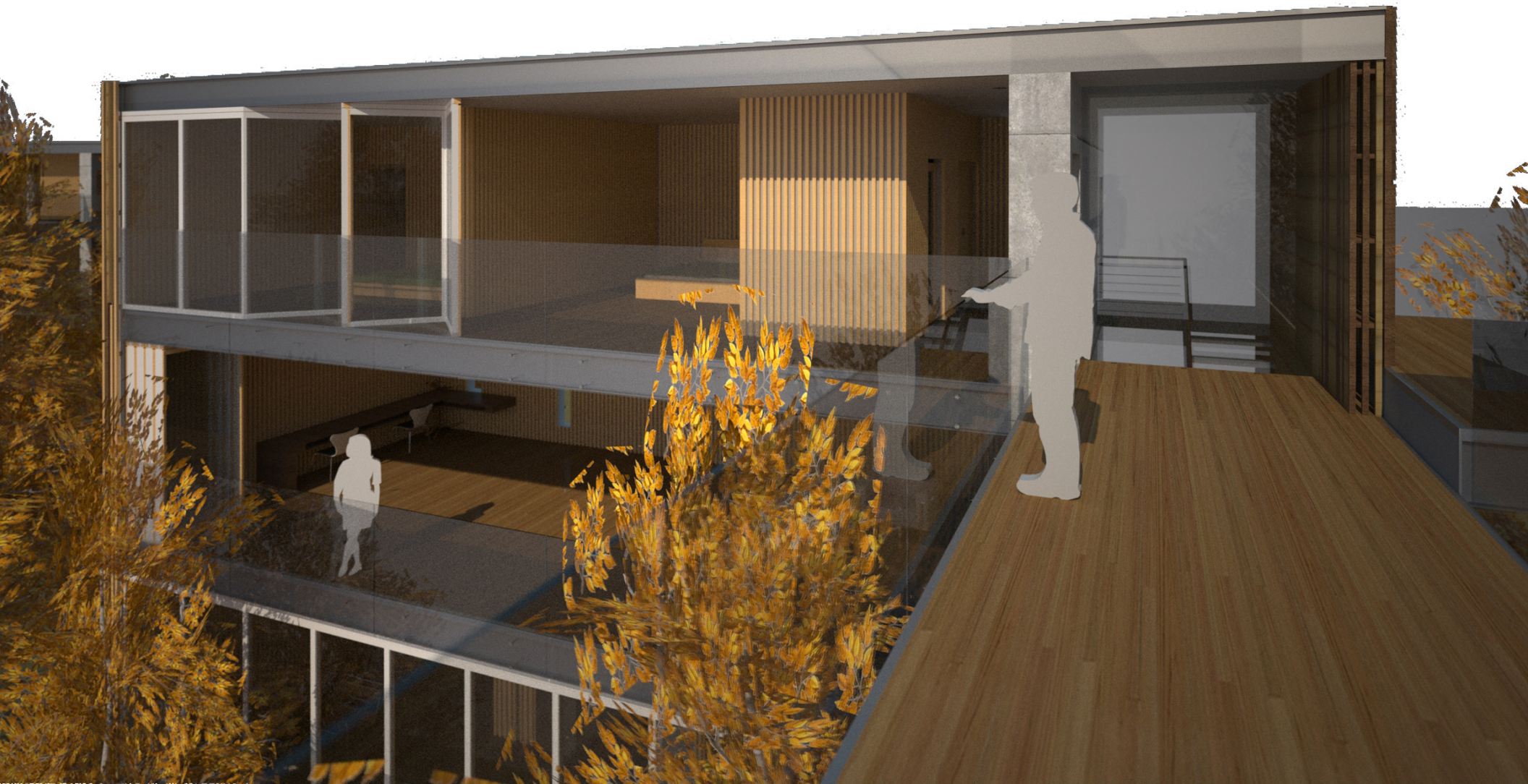





Bibliography

Architecture for Humanity, Stohr, Kate and Sinclair, Cameron. *Design Like You Give a Damn: Architectural Responses to Humanitarian Crises*. Los Angeles: Metropolis Books, 2006.

Bradbury, Dominic. *New Country House*. London: Laurence King Publishing, 2005.

Chiras, Dan. *The Homeowner's Guide to Renewable Energy: Achieving Energy Independence through Solar, Wind, Biomass and Hydropower* (Mother Earth News Wiser Living). Gabriola Island: New Society Publishers, 2006.

Collins, Brad and Predock Predock, Antoine. *Predock: Architect* (Vol. 4). New York: Rizzoli, 2006.
— . *Antoine Predock: Houses* (Vol.3). New York: Rizzoli, 2000.

Collins, Brad and Predock Predock, Antoine and Zimmerman, Elizabeth. *Antoine Predock 2: Architect* (Vol. 2). New York: Rizzoli, 1998.

Davies, Colin. *Key Houses of the Twentieth Century: Plans, Sections and Elevations*. New York: W. W. Norton; Pap/Cdr, 2006.

Decay, Mark and Brown G. Z. Brown. *Sun, Wind & Light: Architectural Design Strategies*. New York: John Wiley & Sons, Inc., 2000.

Faber, Tobias. *Houses in Fredensborg*. Deerfield Beach: Vch Pub, 1992.

Farrelly, E. M. *Three Houses: Glenn Murcutt Architecture in Detail*. London: Phaidon Press, 2002.

Fromont, Françoise. *Glenn Murcutt: Buildings and Projects 1962-2003*. New York: Thames & Hudson, 2006.

Kachadorian, James. *Passive Solar House: The Complete Guide to Heating and Cooling Your Home*. White River: Chelsea Green Publishing Company; Har/Cdr, 2006.

Kemp, William H. *The Renewable Energy Handbook: A Guide to Rural Energy Independence, Off-Grid and Sustainable Living*. Tamworth: Aztext Press, 2006.

Kunstler, James Howard. *Home from Nowhere: Remaking Our Everyday World for the 21st Century*. New York: Touchstone Press, 1998.

— . *The Geography of Nowhere: The Rise and Decline of America's Man-Made Landscape*. Washington, DC: Free Press, 1994.

— . *The Long Emergency: Surviving the End of Oil, Climate Change, and Other Converging Catastrophes of the Twenty-First Century*. New York: Grove Press, 2006.

Maddex, Diane. Frank Lloyd Wright's House Beautiful. New York: Hearst Communications, 2000.

McConnell, Amanda and Suzuki David. The Sacred Balance: Rediscovering Our Place in Nature. Seattle: Mountaineers Books, 2002.

Moller, Henrik Sten. Jorn Utzon Houses. Malibu: Art Consulting Scandinavia, 1980.

Murcutt, Glenn. Glenn Murcutt: A Singular Architectural Practice. Seattle: Images Publishing Dist A/C, 2006.

Ojeda, Oscar Riera and Souto de Moura , Eduardo. Souto Moura: Ten Houses. Beverly: Rockport Publishers, 1997.

Ryker, Lori. Off The Grid Homes: Case Studies for Sustainable Living. Layton: Gibbs Smith, 2007.

—. Off The Grid: Modern Homes + Alternative Energy. Layton: Gibbs Smith, 2005.

Sassi, Paola. Strategies for Sustainable Architecture. New York: Routledge, 2005.

Storrer, William Allin. The Frank Lloyd Wright Companion. Chicago: University of Chicago Press, 1994.

Acknowledgements

I would like to give special thanks to Nate Krug, Bill Borer and Tom Lagging for taking time as jury members in my process critiques. They provided me with several great resources which helped make my project better.

Second, I would like to thank my mentor Martin Despang. His knowledge, guidance and patience helped me a lot during all phases of my project. He was very inspirational to me and continuously made it clear why it's important to design for the common man.

Finally, I would like to thank my family, and in particular my father. Without him, I would have never learned the value of the land, its resources, its natural beauty and just how precious all of it truly is.

