



III. Évfolyam 4. szám - 2008. december

Sipos Jenő

Zrínyi Miklós Nemzetvédelmi Egyetem

sipos.jeno@zmne.hu

Apostol Attila

Zrínyi Miklós Nemzetvédelmi Egyetem

apostol.attila@gmail.com

CAD/CAM, CNC TECHNOLOGY APPLIED IN THE FIELD OF ENGINEERING, SECURITY TECHNOLOGY AND MECHANICAL ENGINEER TRAINING I.

Abstract/Absztrakt

In the last decades the spectacular results of each developmental stages of computer-aided design, were considered as great magic of computer use. Professionals were shocked by the impressive building of engineer works and their more and more realistic appearance. It was hard to believe and for many people it still is that this technology becomes indispensable in everyday engineering work. By now, in front-rank product development, it is impossible to do a competitive designer work without applying the most up-to-date design technology. This all leads to the fact that an engineer student of our days, in his design practice, is definitely going to work with the momentarily most up-to-date technology, which will be out-of-date in a couple of years.

A számítógépek alkalmazásának nagy varázslatai közé számított az elmúlt évtizedekben a számítógépen végzett tervezés egy-egy fejlődési szakaszának látványos eredménye. Szakembereket is meghökkentett a mérnöki alkotások látványos építése és mind valóságosabb megjelenítése. Nehezen hitték, sőt sokan ma is nehezen hiszik azt, hogy a mérnöki munka mindennapjaiban is nélkülözhetetlenné válik ez a technika. Mára az élvonalbeli termékfejlesztésben a mindenkor legjobb tervezési technika igénybevétele nélkül képtelenség versenyképes tervezőmunkát végezni. Ennek következtében napjaink mérnökhallgatója tervezői gyakorlatában minden bizonnyal a ma legkorszerűbbnek számító, de néhány év alatt elavuló módszert leváltó technikával fog dolgozni.

Keywords/kulcsszavak: computer aided design, CAD¹/CAM², CNC³ ~ számítógépes tervezés, CAD/CAM, CNC

¹ Computer Aided Design

Getting to know the world of computer aided design on the level of simple practical usage is merely not enough. For beginner professionals the theoretical, methodological and systemic technological background provides the ability to get an overview of today's technology and its developmental process, in order to properly choose the design methods for his tasks; and to develop together with the area of specialty with the purpose of staying at the right place of high level, competitive work for long decades. Computer aided design is one of the educational programs that are a challenge to learn and to teach as well. The only way to gain significant result is through the individual work and major effort of the students.

Future engineers must possess solid basic knowledge in the fields of methodology of informatics, hardware-software systems and mechanical systems.

For centuries the results of the designer, for himself and his associates, were documented on paper. On the flat paper surface the parts and assemblages, illustrated with the tools of technical drafts, were to be seen in three dimensions through the designer's imagination and the genial communication device provided by technical draft. Designers often dreamt that drafts come to reality and appear in three dimensional realities with original action; and an answer can be received about aesthetic appearance, functioning, and static attributes etc. without constructing a prototype. By now it has become reality. The designer is able to create a virtual world, a description with a never seen content which is suitable for fulfilling the above mentioned dreams. Every necessary device is available for this procedure but engineers need to understand and control them.

In today's industry every company must keep track of the development of computer assisted methods of engineer work, in order to upgrade or simply keep its market position. The security technology and field engineer student of the 21st century has to apply on a very high level such complex engineer applications as CAD/CAM and CNC programs.

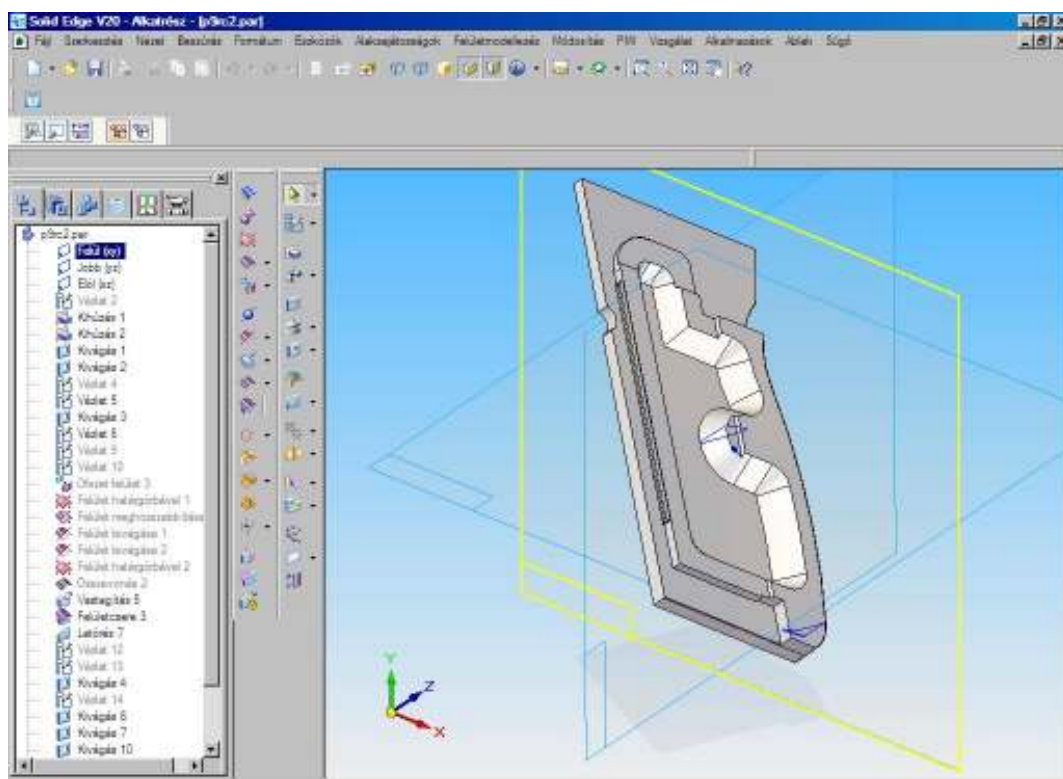

Figure 1: 3D visualization of the P9RC pistol hilt regularly used in the Hungarian Army

² Computer Aided Manufacturing

³ Computer Numerical Control

The CAD/CAM name refers to the system which realizes the integration of computer aided design and production. In this system the model of the part is created, based on that the program is planned for digit-control tools, which is checked by simulation; finally the part is manufactured on a digit-control tool machine or the tool itself is made for the process of manufacturing e.g. caster, steel plate shaper tools.

When changing from traditional piece part design to computer modeled design, the main reason for change is often the transition to digit-control machining. For a long time shape models were solely used for planning NC machining. The CAD/CAM nomination refers to that also. The meaning of computer aided marker has changed thoroughly over the years, as the role of CAD/CAM systems in designer work cannot be compared to the one it played decades ago. At the same time, it is a mistake to believe that according to developed models the suitable toolpath generating procedure can be called for; and then automatically the plan of the machining process and later the NC program is generated. The production specialist has to direct the design while choosing from the various processes of machining, tool machines, and tools, order of machining and strategy of machining.

The NC cutting machining is the basic procedure of shape forming based on form information written in the geometry model, because it is used for the machining of the piece part or also the machining of the tool used for manufacturing through casting, volume-shaping and steel plate shaping processes. In the past years, the development of cutting technology mainly meant fulfilling the needs of digit-control machining. Using informatics provided the possibility to significantly increase the capacity of the cutting process. The tool machine manufacturers make use of this possibility, while the tool manufacturers aim to produce tools which ensure the exploitation of great capacity machines. In the last decade, the competition between informatics, tool machine manufacturing and tool manufacturing led to enormous development of the leading industries; this development can be sensed by common people through using their cars, household appliances and other industrial products. By now, it has become reality to meet the shape model created by the most advanced methods.

The role of shape is very determining when designing mechanic parts of appliances, machines and devices manufactured in industry; and their characteristics can be assigned to shape. The designed parts and tools used for the part's production – both are designed by engineering and design considerations - are more and more often acquire their shape by some kind of cutting process automated by computer, where the control program of the digit control manufacturing machine is created by the description written on the shape computer.

The same shape can be described by different kinds of methods, but the description, by all means, must include the necessary information for use – in our case for planning the way of tools applied in cutting procedures defining the shape. The CAD engineer creates in the computerized center, which is an extended and effective device system, of his work filling a determinative part. The CAM covers the process of receiving the description of shape, designing the tool tracks and control program, and the computer-aided digit-control machining.

In this case the diameter and the height of the cylinder provide sufficient information for the plan of machining. This means that the computerized description for planning of machining is sufficient to include these two data apart from the type of shape (now it is the cylinder). The spatial machining-design of parts are simplified by solving it as a planar assignment, in other words we trace it back to the solution of another planar task. The so called free-shaped surface directs the cutter along the spatial curve which is calculated by the descriptive function of the spatial surface.

So products, that need more serious considerations, are developed through experimentations attempted on the prototype. This work consumes a serious amount of money and it also delays significantly the market appearance of the product, but leaving or neglecting

it results in a poor quality, commonly full of teething-troubles product. Prototypes often operate in real working environment for years till the construction qualifies for quantity production.

Nowadays it is more and more common that for the above delineated traditional design and prototype-experiment there is simply the time needed is not available, and at the same time probable results are not satisfactory. Designers need such devices which make it possible to get acquainted with more and more characteristics of the product in their offices in order to eliminate or at least to decrease the need for workshop-made prototypes, test production, experiments and studies. The technology, which is based on methods of modeling and other developed informatics, of today's computerized design was developed to fulfill the changed requirements. The fast development of up-to-date and high-efficiency computerized design systems was generated by definite industrial demand and the debased computer-capacity made it possible.

We often hear about design systems that are two-dimensional (2D) or three-dimensional (3D). The real world is obviously always three-dimensional, but in technological design many tasks can be solved in a more simple two-dimensional way. For example a half intersection of a pivot provides sufficient information for any kind of design work. However today's models are realized in three dimensions most of the time. Two-dimensional methods are still in use but primarily in 3D systems.

First in computerized design, as copying the method of design work on the drawing-board, design systems appeared capable of creating technical drawings and they spread quite rapidly. The drawing on the screen was made by interactive graphic framing, the repetitive parts of the drawing were made possible to store and retrieve. A momentous reduction in time demand of the preparation and remodeling of design documentation appeared.

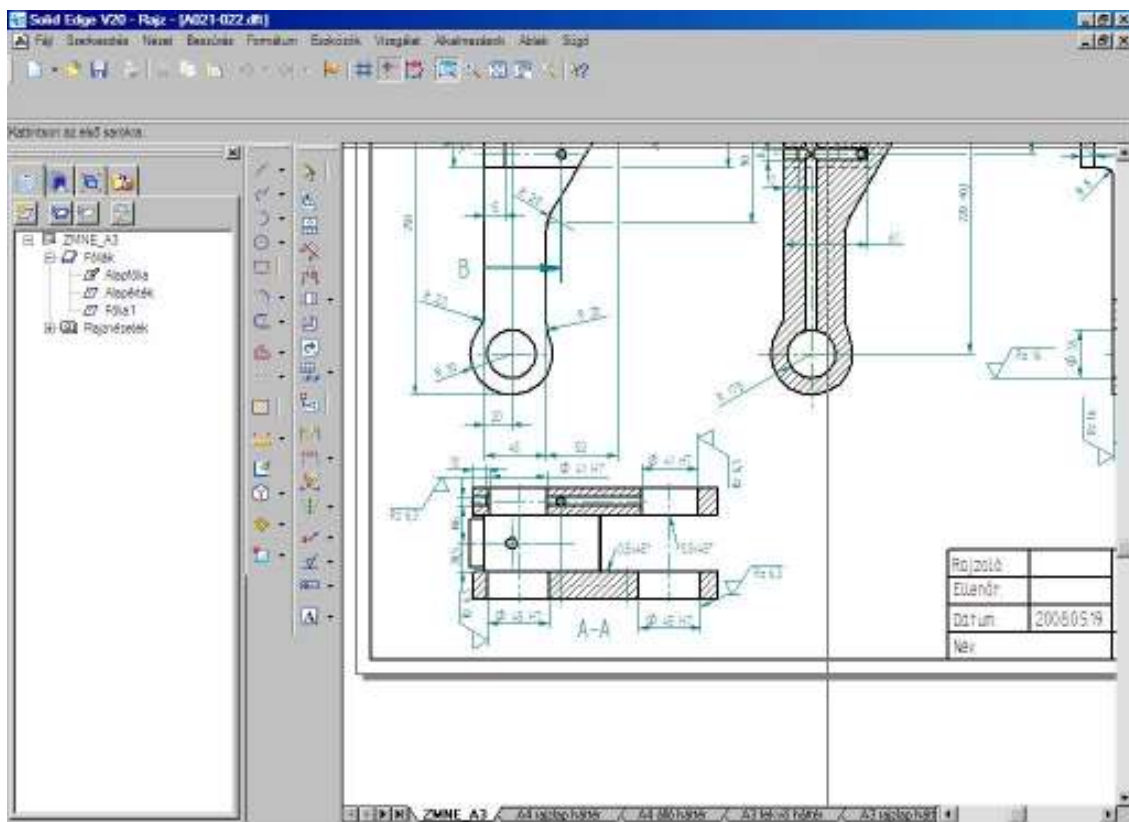

Figure 2.: Creating a technical drawing by a couple of 'clicks'.

Nowadays the up-to-date computerized design is represented by modeling procedures, directed by the designer and achieving his conception, which are able to create a technical drawing from the model; and at the same time they already include intelligent methods of calculation occasionally.

The chain of decisions provides the backbone of the designer's work. He makes the designer work according to his own decisions and also other's former decisions. Neglecting any decisions can lead to the complete inefficiency. Accordingly the up-to-date modeling procedures support, with more and more functions, and control the designer decisions helping substantially the designers' work. The built-in procedures in the computer allocate or select suggestions for the decision of the designer. At the same time the up-to-date designer procedures do not allow any building or modifying operations on the model that are not suitable for any earlier decisions or rules.

Being associative is an allotted correlation which is defined in the language of modeling between fixed information in the model. This is not sufficient by itself because the unchangeability of the complicated calculations, analysis and finally measures resulted from the decisions etc. must be ensured. In this model the measures resulted from the decisions must be described as unchangeable restrictions.

The system of restrictions ensures that the already decided and accepted designer results can only be changed through an allotted authorization process or cannot be changed at all. However the creative work of the designer must never be restricted with unprovoked restrictions.

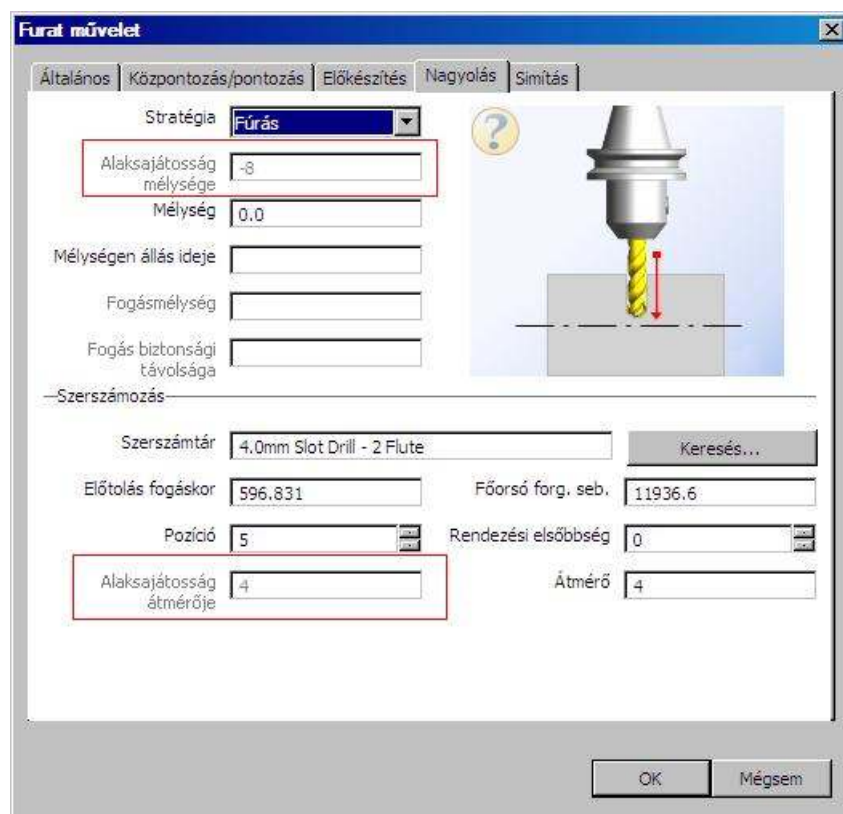

Figure 3.: The restriction of the bore (depth and diameter) identified as shape idiosyncrasy

The processes of design are in communicative relation with the designer through interactive graphic user interface and according to the designer's orders they create the result-

information which is placed into the data base afterwards. The shape description is placed into the data base and then it is used for creating technical drawings and NC control programs.

One of the traditionally fundamental tasks of computerized design is the creation of technical drawing documentations. The technical drawing is the tool of two dimensional visualization of a three dimensional part. It includes views, segments; and measures and other scores located on them according to the specifications of the referring standard. The drawing-framer procedures on the computer make it possible to create and modify entities such as line, line-chain, dimension line, stripping etc. Technical drawings are stored as data files in allotted format so it is possible to open, modify, contemplate on screen, print on paper with a printer or a plotter, or forward to other computers through a computerized network. The complex recurrent components on the drawings need to be worked out only once. Drawing elements, drawing-parts and complete drawings' assortments can be stored in files; they can be retrieved and re-dimensioned etc. Standard and very often occurring drawings, assortment of drawing elements can be ready bought. For example for binding elements complete catalogues can be bought in the form of drawing data bases.

The associativity between the 3D shape description of the parts and the assembly units and the 2D drawing views, segments is to ensure that the modifications of the models take place on the drawing views and segments also.

The up-to-date drawing tools are also capable of automatic sizing. The drawing views are created in the case of 3D drawing or shape modeling; editing on the views and on the 3D visualization can also be done as there is a bi-directional associativity between them. This means that the modification of the three-dimensional drawing or model denotes the automatic modification of the drawing views and it is also true the other way around.

The designer graphic is in interactive connection with the design methods. Interactivity means that the designer conducts the functioning of the process with information input, at the same time the process asks for information from the designer depending on the results of completed procedures and it informs him about results and incurred irregularities.

On the user interface the design of the drawing or model takes place in a frame-window. The designer can point on the entity which he wants to use or modify in his following procedure in the course of framing. The functions attained by design processes can be chosen from a menu and they are also accessible by orders written in the command language of the design system. An order includes those parameters which compulsively must be given or optionally can be given for the chosen process as starting data. A parameter often points to a previously created model-entity that we would like to use for creating the new entity, in this way for dot, line, surface, body, piece part, assembly unit etc. The elementary forms used for building the model of the part is later on called shape-idiosyncrasy.

Under the top edge of the screen rolling-down menu lines are often set, which provides the permanently accessible functions in the design system; for example for file managing, setting the visualization mode the design functions are usually can be reached from a textual or an icon-type menu system. The designer can re-compile the menu system accordingly his needs, so that in reaching the actual often used functions it is not necessary to 'walk around' in the menu system.

The framing window of the graphic user interface is an interactive communicational interface, which displays as much information at a time, towards transparency, as really needed for the interactive framing procedure next in line.

When constructing a model in 3D parts and assembly units are described in an imaginary three-dimensional, so-called model space. The designer rotates the part on the screen into the most comfortable position for framing with changing the relative position of the model space and the screen-surface. The model space is viewed from another outside point.

The technical designer system, as system of application, has resort to the services of the operating system and other joint system-software elements. The operation of the computer is conducted by the operating system. The functions offered by the graphic system, which ensures the interactive graphic screen maintenance, are used by the programs of the technical designer system. The graphic user interface consists of the window-manager, which is available outside the technical designer system, and on the other hand those programs that are built into the designer system. Apart from the functions of the network system the significance of the internet devices has increased in the last few years. The designer systems provide direct internet connection. The built-in data base management programs in the designer system utilize the functions of the data base management system in order to simultaneously and multiply reach the database involving the models and technical documentations. Besides the program-developing devices integrated into the designer system or rather connected to them, general program-developing tools are applied.

The technical designer systems are modularly structured to facilitate that the future user configures his system choosing the necessary modules from the module system offered by the developer. The module supplies tools for a group of functions that are assorted by considering coherent and business viewpoints. The user purchases or rents the chosen modules.

The technical designer system can operate on individual computers or on computer network. In the case of a network the modules of the technical designer system can be installed separately on every single computer of the system. This solution is not considered to be up-to-date especially when to every computer involved a separate database belongs and the danger of multiple models, one model in many files, exists. This solution is disadvantageous in the position of both the occupied storing capacity and the program updates.

The establishment of the technological process model starts on the basis of the piece part's model. It is needed to have information about the manufacturing machines and manufacturing tools which provide basis for the procedure. This information can derive from models or from data files, which is more common nowadays, simply stored in data bases. In the case of smaller capacity systems the production planner gives the data of tool machines and tools with a direct dialogue. The process can be established and analyzed on the basis of a widely understood model consisting of the technological procedure model, piece part model and the manufacturing tool models. For the tool-cycle entity the tool-paths are determined according to the entities chosen from the piece part model and the measures of the selected tool. Practically, the tool-path calculation is completed in the geometrical model by the functions defined in the processing model-creator. This computational operation can be modified by several parameters such as the allowed margin of safety for the next cutting operation, the specified punctuality of machining and so on. In the operation entity appears the identity of the chosen tool-machine and the tool clamping device. In the same way the operation-element entity points to the model of the cutting tool.

The period of machining includes, based on the given shape model entity or entities, the created tool-paths' sequences in accordance with the chosen machining strategy and the initial conditions and parameters as well; and it is independent from the applied NC controls. This means that with a suitable post-processor for any kind of proper controls it is possible to create a control program directly capable of tool-machine control. The post-processor takes into consideration the idiosyncrasies of the chosen tool-machine.

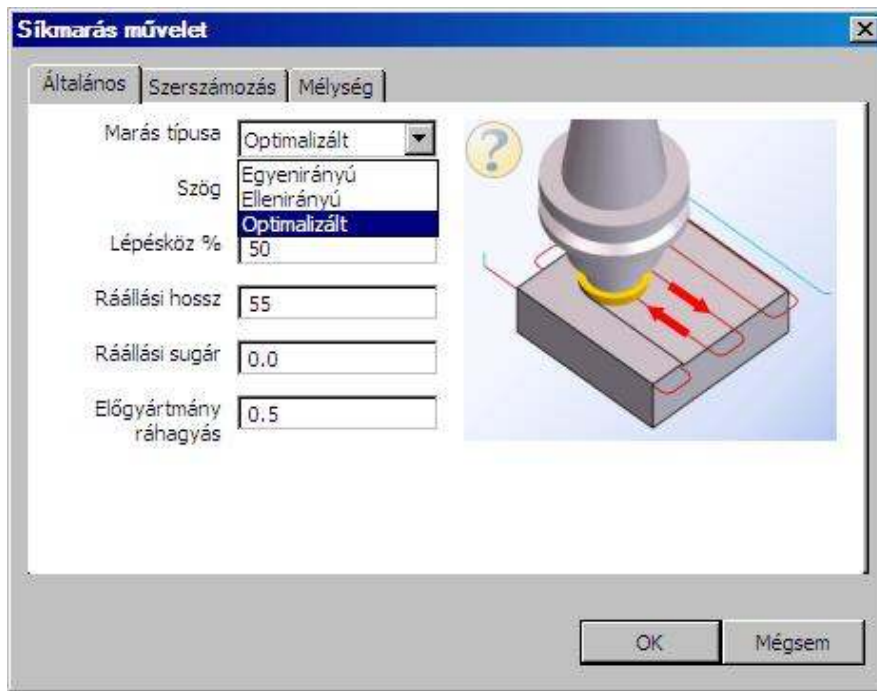

Figure 4.: Selection of machining strategy (type of cutting) with graphic and textual support

The most important aim of computerized design is to shorten the elapsed time from the beginning of design to the manufacturing of the product. Although the error of the NC control program can be corrected at the tool-machine but this postpones the start of part machining, through that it endangers the whole program of production and keeping the strict transportation deadline. For this end, it is at great significance to check both the machining periods and the control program completed after post-processing with computerized simulation. The process of monitoring the cycle of machining covers the entirety of the cycle, the correctness of the individual tool-paths, the attainability of carriage-movements; and the avoidable collisions during machining in the working space of the tool-machine. For the last two examinations the model of the tool-machine is needed. The collision-examination is of very high account for example in the case of machining-centers, where besides complicated prismatic accessories and holders, after one another, many considerably complex shaped mechanized tool moves in the working space of the tool-machine.

The modeling of tool-machines and tools does not cost too much since the model of a tool-machine is needed to be completed only once. The models of cutting tools and cramping appliances can be created by parametric design and alongside the application of the same type, the same model is possible to use.

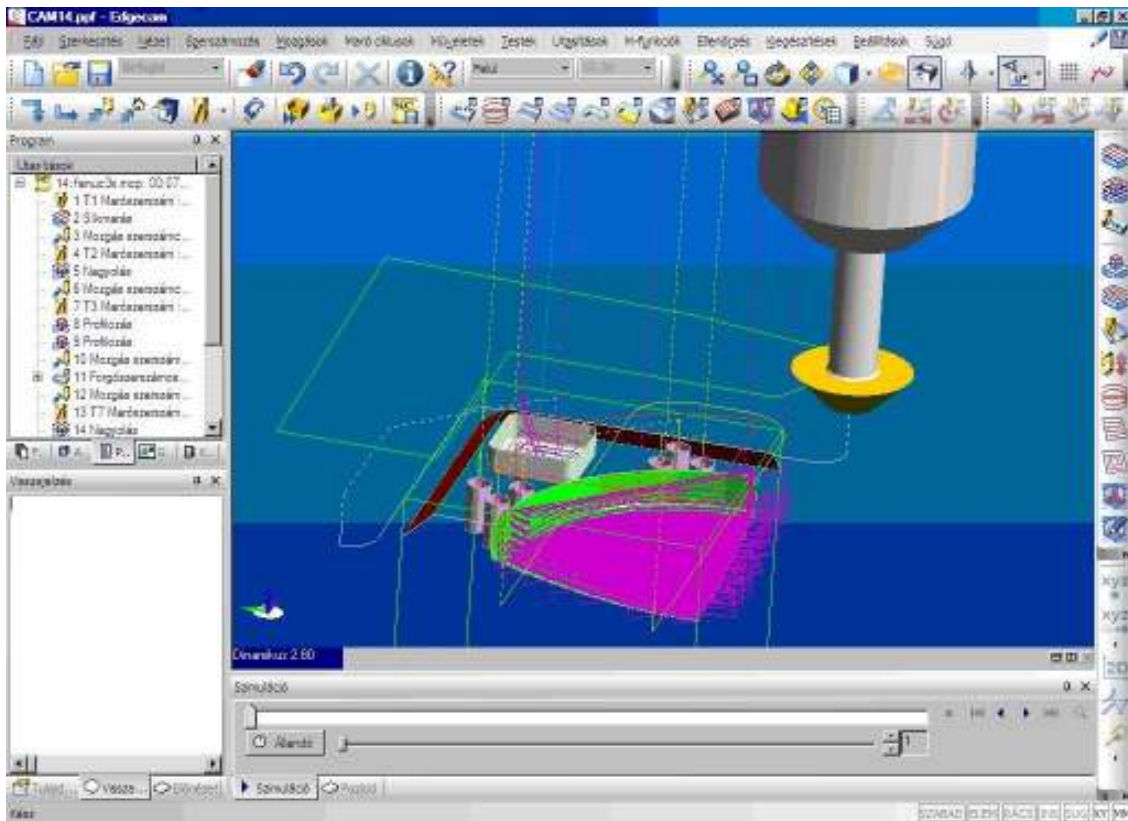

Figure 5.: Calling in a tapered tapered cutter, with parametric definition, from the tool database

It is subservient to test the completed NC control program after post-processing yet in the technical design system with a simulation.

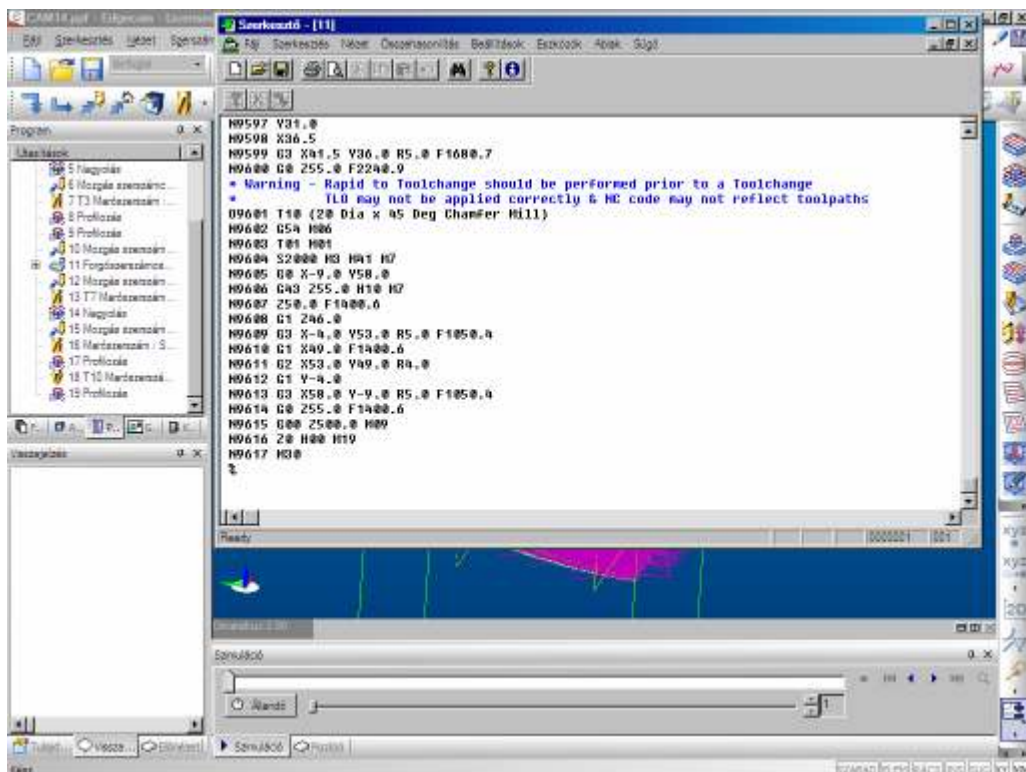

Figure 6.: Post-processing at a keystroke

The ready NC control program must to be transferred to the controls of the tool-machine. Nowadays the data medium is a pen drive or network.

In the practice, the Numerical Control means the control of the tool path and switches information. Switches are needed among other things for modifying revs, feed and also tool changing. The tool path and tool shape together define the material detachment; and through that the shape of the wrought part. The description of the tool's position in motion is made possible by the co-ordinate system which is ordained to the working space of the tool. Certain co-ordinates are ordained to certain carriage-movements. Carriage-movements are called axis in the terminology of digit-control. The X, Y and Z mean rectilinear carriage-movement in the direction of the X, Y, Z axis; the A,B and C mean slew around the X, Y, Z axis; the U, V and W mean second movement parallel the X, Y and Z axis or the parameter of the tool-correction.

You can read about the steps of the complete tool's birth in the II. section, the programming of the propelled axis in detail in the III. section of this series.

APPLIED BIBLIOGRAPHY

Apostol Attila: Példatár CNC szerszámgépek programozásához, NCT-104M, Budapest, 2007.

Dr. Horváth László: CAD/CAM TECHNIKA I. Bevezetés a gépészeti rendszerek és gyártásuk számítógépi tervezésébe, Bánki Donát Műszaki Főiskola, Budapest, 1998.

Mátyási Gyula - Sági György: Számítógéppel támogatott technológiák CNC, CAD/CAM, Műszaki Könyvkiadó, Budapest, 2007.

www.graphit.hu/plmsupport „EdgeCAM kezdőlépések”

www.graphit.hu/plmsupport „Solid Edge Alaptanfolyam V18”

www.graphit.hu/plmsupport „Solid Edge haladótanfolyam V18”

PROGRAMS INTRODUCED IN THE ARTICLE

Edgecam 12.5 program

Solid Edge V20 program

NCT-104M program