

UDC 622.765

P.V. SERGEEV, Dr.T.Sc.,
V.S. BILETSKIY, Dr.T.Sc.
(Ukraine, Donetsk, National Technical University)

RESEARCH PRACTICE OF COAL PARTICLES ELEKTROSURFACE PROPERTIES IN AQUEOUS SUSPENSION

Describes the methodology of the study electrosurface properties of coal particles in aqueous suspensions using suspension and osmotic effects. Shown rational fields of application of these methods.

Statement of the problem and the state of its study. Since the surface charge of the coal particles in water has a significant impact on the selective flocculation process by hydrophobic organic substances, highly concentrated coal-water fuel preparation, electrosurface properties evaluation of solid components suspensions is essential. Work analysis on this issue has shown that the measurement results of coal particle electrokinetic potential are ambiguous, and often contradictory, even within same coal type [1]. The absolute value of coal particle ζ -potential and its sign depends not only on the surface properties but also on the conditions of the experiments. On the basis of these conflicts, it is necessary to improve the reliability of the experimental results by comparing the data obtained in research by several ways.

Purpose of the work is choice and rational investigation method description of electrosurface coal particles properties in aqueous suspensions.

The main material. We considered two estimation methods of coal particles electrosurface properties in aqueous suspensions:

- evaluation of coal particle electrosurface properties by suspension effect method;
- measuring of the particle ζ -potential by electro osmosis.

Method of the coal particle surface charge estimation on basic of *suspension effect* is that clear filtrate was separated from the reduced to equilibrium dispersed system, then pH is measure in suspension remainder (pH_s) and the filtrate (pH_f). The relative charge magnitude of the dispersed phase and its sign are evaluated by the suspension effect indicator ΔpH [2]:

$$\Delta pH = pH_s - pH_f. \quad (1)$$

Accordingly studying coal samples are given to the sorption equilibrium with aqueous solutions of $NaOH$ and HCl , providing the limits of the suspension pH from 2 to 12. Equilibrium is considered like achieved one when the pH difference in de-

Special and combined methods

canted and new added solution does not exceed the measurement error (0,01 pH). Suspension equilibrium is achieved in two days. As the ΔpH value depends on the solid phase concentration in suspension, it is kept at the same level namely 30% of mass. Centrifugation mode and the filtrate amount selected for measuring also are stabilized.

pH measurement is effected by ion meter I-115M, which previously is calibrated by means of control buffer solutions. Suspension effect rate calculation is made by the equation (1). Measurement results are averaged over 4-5 measurements. The confidence interval is $\Delta x = 0,015 \text{ pH}$.

According to the established model of the electrical double layer (EDL), electrokinetic potential is a part of full or thermodynamic potential surface. The last one depends mainly on the potential-determining ions content in a solution while ζ -potential is defined by the counter ions distribution in EDL. The more ions have same sign with counter ions in solution, the less ζ -potential has value, at certain electrolyte concentration in solution system can move in isoelectric state when the ζ -potential value is equal to zero.

In disperse systems EDL determines the nature of electrokinetic phenomena: electroosmosis, electrophoresis, Dorn effect and potential leaks occurrence.

Considering electroosmosis as fluid flow in porous media under the influence of an external electric field, Helmholtz and Smoluhowski developed a theory [3], according to which the electrokinetic potential is defined as:

$$\zeta = \frac{\mu \cdot \chi \cdot v}{D \cdot D_o \cdot I}, \quad (2)$$

where μ is the liquid phase viscosity, $\text{H}\cdot\text{c}/\text{M}^2$; χ is specific electrical conductivity of pore liquid, $\text{OM}^{-1}\cdot\text{M}^{-1}$; v is electroosmosis volume velocity, $\text{M}^3\cdot\text{c}^{-1}$; D is the liquid dielectric constant; D_o is absolute permittivity of vacuum; I – current strength, A.

The pore fluid conductivity value, as shown by Bikerman, Fridrihsberh and etc. consists of free solution specific conductivity (χ_v) and surface conduction (χ_s) of EDL ion diaphragm, i.e.:

$$\chi = \chi_v + \chi_s.$$

Taking into account the surface conductivity can significantly reduce abnormal ζ -potential dependence on diaphragm component dispersion.

As it was noted, research results of electrokinetic phenomena on coal are sometimes contradictory as the absolute values of coal ζ -potential are changing and hard

Special and combined methods

recovered [1, 4]. These assumptions should be agreed as in structural and chemically different type coal surface is extremely diverse. Heterogeneity is primarily concerned with side chains from heteroatoms oxygen, sulfur, nitrogen are in coal macromolecule; hydroxyl, carbonyl and other functional groups, and active radicals with free valences are presented. As a result, in the "coal – solution" system on the coal particle surface a wide variety of active sites, causing the "mosaic" surface nature, are produced. All this leads to some concept convention of homogeneous EDL on the border "coal – liquid". At the same time the surface electrical properties research can provide important quality information about dispersed coal particle interaction mechanism in aqueous medium at selective flocculation.

The plant scheme for electrostatic research (design by Papushin Yu.) is shown in Fig. 1. Plant allows defining the magnitude of the fluid osmotic movement, its specific conductivity and powder diaphragm surface conductivity.

Elektroosmotic plant (EOP) made of organic glass and contains the elements:

- Removable glass for the investigated powders;
- The side cameras;
- Graded capillaries;
- Electrolytic agar keys;
- Additional burettes;
- Flat platinum electrodes;
- Removable filters;
- Platinum rod electrodes;
- Electrolytic vessel with copper electrodes.

The electrical scheme of external connections EOP is shown in Fig. 2.

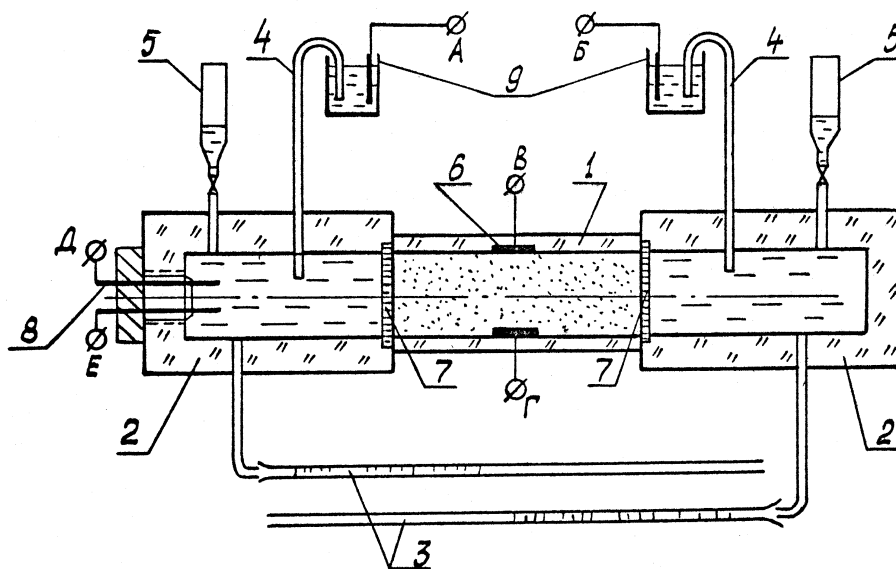

Fig. 1. Scheme of elektroosmotic plant (EOP) for determining the ζ -potential

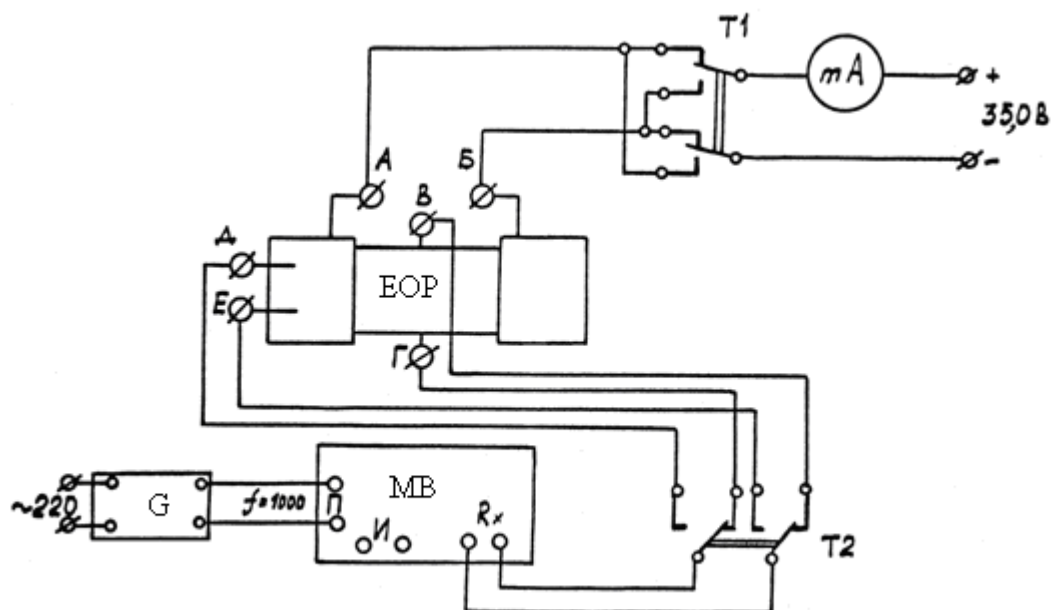

Fig. 2. Scheme of elektroosmotic plant external connections

To change the elektroosmotic liquid transfer direction there is switch T1, current control is performed by the milliamperemeter from outside measuring of 0-10 mA. Determination of the solution electrical conductivity (χ_v) and surface diaphragm conductivity (χ_s) is effected by using electrodes (8) and (6), measuring bridge (MB) and the generator (G), which operates at a frequency of 1000 Hz.

Method of ζ -potential measurement. Investigated coal powder of narrow class size of 50-100 microns is reduced to the sorption equilibrium required degree with the liquid phase of defined ionic composition. Wet coal sample is placed in a removable glass (1), one end of which is closed by filter (7), and is compacted to filling by vibration. The glass closed by another filter with obtained diaphragm is clamped between the side cameras (2), and then the plant is filled through the burettes (5) with side liquid to complete displacement of air voids. Using burettes cranes horizontal capillary meniscus are specified at zero valuation. From direct-current source through the electrolytic keys tension is fed and the elektroosmotic transfer start time (EOT) is fixed.

To reduce the influence of the diaphragm chemical "poisoning", the total measurement time is limited to 20-25 seconds. Volume EOT value is estimated by meniscus shear in the capillaries at a fixed time.

After making experiments on EOC volume and surface conductivity of the content system are measured. The specific solution electrical conductivity in the volume (χ_v) and the solution conductivity with the same diaphragm (χ_s) are calculated by the value of free liquid resistance (R_v) with the diaphragm (R_g) and plant constants (C_v i C_g):

$$\chi_v = \frac{C_v}{R_v} ; \quad \chi_g = \frac{C_g}{R_g} .$$

The value of R_v and R_g determined by the known bridging method over the scheme shown in Fig. 2. The plant constant C_v and C_g are previously determined using standard electrolytes, as shown in [5].

Calculating the coal particle ζ -potential by the equation (2) the following constant values are taken: $\mu = 0,001 \text{ Pa}\cdot\text{c}$; $D = 81$; $D_o = 8,854 \cdot 10^{-12} \text{ A}\cdot\text{c/ V}\cdot\text{m}$.

Conclusions

1. To improve the results of research reliability and accuracy of coal particle elektrosurface properties in aqueous suspensions both the suspension and the effect of osmosis are advisable to use, comparing the data obtained.

2. In case when the determining problem of the coal particles charge is stated only for sign the use of one method – the suspension effect can be restricted.

References

1. Назаренко В.М., Могилевская Е.Е., Шантер Ю.А. О связи между электрокинетическим потенциалом и флотацией // Обогащение и брикетирование углей. – М.: ЦНИЭИУголь, 1969. – № 2. – С. 12-13.
2. Исследование суспензионного эффекта / Ю.М. Чернобережский, Ю.Н. Зубкова, С.Д. Усанова, Л.В. Афанасьева // Коллоидный журнал. – 1965. – Т. 27. – № 5. – С. 780-783.
3. Духин С.С., Дерягин Б.В. Электрофорез. – М.: Наука, 1976. – 324 с.
4. Зубкова Ю.Н., Лопанов А.И. Особенности электроповерхностных свойств углеродистых веществ в растворах электролитов и их связь с флотацией // Химия твердого топлива. – 1982. – №2. – С. 100-102.
5. Айвазов Б.В. Практикум по химии поверхностных явлений и адсорбции. – М.: Высшая школа, 1973. – 208 с.

© Sergeev P.V., Biletskiy V.S., 2013

*Надійшла до редколегії 12.09.2013 р.
Рекомендовано до публікації д.т.н. О.І. Назимко*