

Magnetic and power separation

UDC 622.7

A.I. ZUBAREV

(Ukraine, Dnipropetrovs'k, National Mining University)

THE EXPERIMENTAL RESEARCH OF MAGNETIC SUSCEPTIBILITY OF MANGANESE SLUDGE

The experimental research of specific magnetic susceptibility of magnetic crops of granular manganese sludges of one of Nikopolskiy Basin sludge depositories has been done. The results of the research show that the magnetic crops studied have sufficient difference in magnetic susceptibility for crude sludge treatment with dry magnetic separation methods.

Introduction

Nikopolskiy Region concentrates comparatively large depositories of manganese ore dressing wastes, among which oxide and mixed manganese sludges stand out. The preliminary analysis shows that granular part makes up to 50% of the whole volume of stored sludges. Involvement into processing the given raw material with the dry magnetic separation technique, in prospect, will provide reduced cost of searching and developing new deposit, will allow growth of qualitative manganese concentrate, will clear the land occupied by sludge depositories for reclamation, will eliminate environmental pollution sources, will reduce the problems of draining and water consumption, will improve complicated ecological situation itself nearby operating ore dressing enterprises. The results obtained regarding experimental observation of magnetic susceptibility of manganese products will allow enlarging understanding of essential separation characteristics of devices and range of controlling technological parameters of dry magnetic ore dressing process.

Task definition

The objective of the research is experimental determination of magnetic susceptibility of manganese sludge as function magnetic field intensity.

Theoretical bases of determining magnetic susceptibility of manganese products

Magnetic force affecting a sample in the magnetic field is calculated according to the formula (Karmazin 1978 & Svoboda 2004):

$$F_m = \mu_0 * \chi * m * H * |\text{grad}H|, \quad (1)$$

in which μ_0 – magnetic constant, $4\pi * 10^{-7}$, H/m; χ – specific magnetic susceptibility, m^3/kg ; m – the weight of the sample, in suspension, kg, H – the magnetic field intensity (strength), A/m; $|\text{grad}H|$ – gradient of the magnetic field intensity, A/m^2 ; x – a coordinate measured along the axis of the studied sample, mm.

To carry out the present experiment, a few variants of magnetic systems were considered. According to the results of series of preliminary research we chose the

Magnetic and power separation

variant, equipped with a magnetic coil with a magnetic conductor and metal core (Figure 1). The magnetic coil with the outer diameter 360 mm and the internal opening diameter 85 and 90 mm height is made of copper bus rectangular in shape, cross-section $1,5 \times 3,5 \text{ mm}^2$. A metal core with a 60mm diameter is placed into the coil to increase the magnetic field intensity in the operating area. For this variant of the magnetic system the degree of the magnetic field nonuniformity was that which allowed neglecting the change of required magnetic susceptibility χ through the change of the magnetic field intensity within the operating area. The operating area implies that part of space in which the studied sample is placed, restricted by the surfaces: underneath and from above by horizontal planes removed from the top of the core for 4 and 10 mm correspondingly; from sides by a cylindrical plane, coaxial with a coil and, diameter, $d = 26 \text{ mm}$

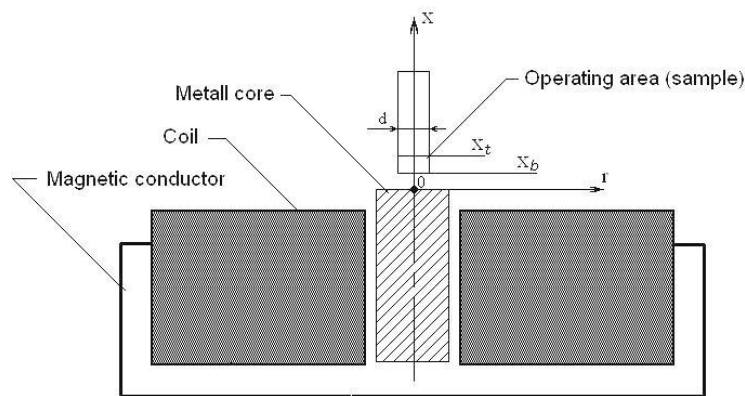

Fig. 1. The variant of the magnetic system with the operating area to carry out the experiment

Thereat, the given variant of the magnetic system ensures constancy of the gradient of the magnetic field intensity $|\text{grad}H|$ within the operating area and the sample volume correspondingly, and the average length value of the sample can be taken as H .

$$H = \frac{H_t + H_b}{2}$$

H_t and H_b are vector projections of the magnetic field intensity onto axis x at top and bottom points of the operating area, correspondingly:

$$H_t = \frac{B_t}{\mu_0};$$

$$H_b = \frac{B_b}{\mu_0},$$

in which B_t and B_b are unit values of the magnetic field density at the top and bottom point of the operating area correspondingly which were measured with an electronic

milliteslameter "ИИ43.2214".

In case of a small change the magnetic field intensity in radial direction, the gradient of the magnetic field intensity $|gradH|$ can be accepted approximately:

$$|gradH| \approx \frac{dH}{dx} \approx \frac{dH_x}{dx} \approx \frac{H_t - H_b}{x_t - x_b}; \quad (2)$$

$$H_r \approx 0, H = H_x, F_{m,r} \approx 0, F_m \approx F_{m,x},$$

in which x_t and x_b are coordinate x values in top and bottom parts of the operating area correspondingly.

The specific magnetic susceptibility of the sample is found from formula (1), taking into account the replacement (2):

$$\chi = \frac{F_m}{\mu_0 * m * H * \frac{dH}{dx}}. \quad (3)$$

The minimal weight of Sample m , for which the filling coefficient does not change with the volume increase, should be no less than 2,9 g (Mladetskiy 2011)

The experiment description and the results. The initial sample of the granular manganese sludges underwent magnetic fractionation on a laboratory magnetic roller separator with various current values in the coil. The result of the separation and chemical analysis of the products obtained are presented in Table 1.

Table 1

Characteristics of the presented magnetic crops of the manganese sludges.

Number of magnetic crops of the manganese sludge (of Sample)	The current value in the roller separator coil, A	Magnetic crop output, %	Manganese content, %
1*	0,5*	0,7*	11,7*
2	1,0	19,9	42,8
3	1,5	10,6	40,6
4	2,0	4,2	41,7
5	2,5	1,9	36
6	4,0	1,3	29,6

* The preliminary mineralogical analysis of the crops obtained, showed the occurrence of ferromagnetic phase in terms of concretion and ferruginization of manganese minerals (up to 5%) in Sample1. Taking into consideration the low output of the product, determining its specific magnetic susceptibility is not depicted in the article, and these values are presented in the conclusions.

To measure magnetic susceptibility of the presented probes a certain stand has been prepared equipped with the specified magnetic system, weight measuring device removed from the effect of the magnetic field, a rigid lifting bar for a test tube with the sample, direct current source which provides electricity supply to the stand with a

Magnetic and power separation

magnetic coil up to values of 20 A with voltage of 110 V.

According to the research methods the magnetic crop sample was loaded into a cylindrical container with the inner diameter 26 mm, and consolidated to the required level. The container was secured on a lifting bar and moved into the operating area coaxial to the coil and core in such a way that the flat bottom of the sample (the internal container bottom) was at level $x_b = 4$ mm from the top of the coil, and the top of the sample was at level $x_t = 10$ mm. Further, the sample was weighed without magnetic field and with different values of the current in the coil correspondingly. According to the results of weighing, the magnetic force affecting Sample F_m was determined. The weighing was done with an electronic weighting unit of RADWAG WPS 210/C/2 type.

The results of measuring the magnetic force F_m and conditions under which the experiment is conducted (the sample number, weight, current force, induction in the operating area) as well as the results of χ according to formula (3) are given in Table 2.

Table 2

The results of measuring the magnetic force F_m , experiment conditions and calculation data χ

No. of an experiment	No. of tests	I, A	m , g	F_m , mN	H , kA/m	$\frac{dH}{dx}$, kAm ²	$\chi \cdot 10^{-6}$, m ³ /kg
1	2	6	5,43	0,706	147,8	1856,8	0,377
2	2	8		1,088	188,8	2520,0	0,335
3	2	12		1,853	249,1	3183,1	0,343
4	2	16		2,554	305,2	3713,6	0,330
5	2	20		3,791	359,3	5039,9	0,307
6	3	6	5,68	0,657	147,8	1856,8	0,335
7	3	8		0,961	188,8	2520,0	0,283
8	3	12		1,588	249,1	3183,1	0,281
9	3	16		2,206	305,2	3713,6	0,273
10	3	20		3,339	359,3	5039,9	0,258
11	4	6	5,55	0,569	147,8	1856,8	0,297
12	4	8		0,833	188,8	2520,0	0,251
13	4	12		1,460	249,1	3183,1	0,264
14	4	16		1,988	305,2	3713,6	0,252
15	4	20		3,022	359,3	5039,9	0,239
16	5	6	5,85	0,549	147,8	1856,8	0,272
17	5	8		0,814	188,8	2520,0	0,233
18	5	12		1,471	249,1	3183,1	0,252
19	5	16		2,010	305,2	3713,6	0,241
20	5	20		3,098	359,3	5039,9	0,233
21	6	6	5,77	0,373	147,8	1856,8	0,187
22	6	8		0,559	188,8	2520,0	0,162
23	6	12		0,951	249,1	3183,1	0,165
24	6	16		1,356	305,2	3713,6	0,165
25	6	20		1,925	359,3	5039,9	0,147

According to the results we have constructed dependency diagrams of specific

magnetic susceptibility χ of different manganese sludge crops as a function of the magnetic field intensity (strength) H (Figure 2).

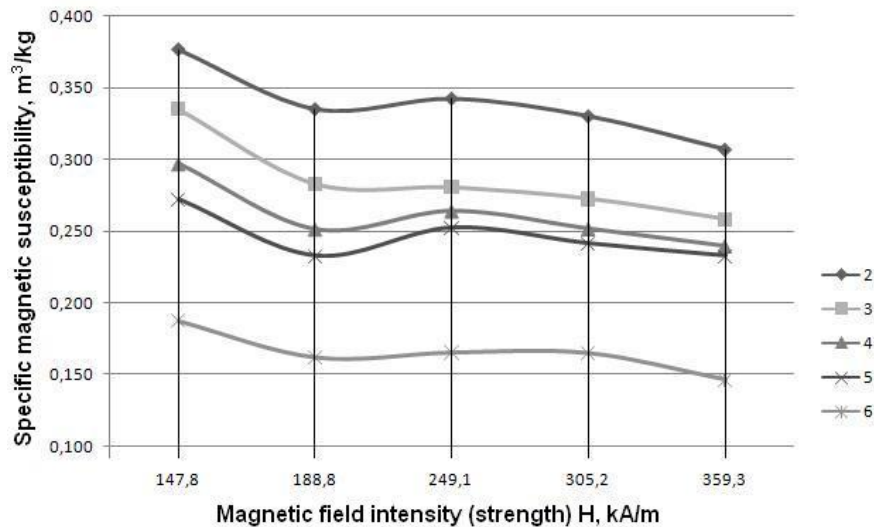

Fig. 2. Dependency of specific magnetic susceptibility of different manganese sludge crops (coarseness 0,15-2,0 mm) upon the magnetic field intensity (strength)

The fractional accuracy of the experimental determination of the specific magnetic susceptibility can be found according to the following formula:

$$\Delta = \delta_1 + \delta_2 + \delta_3 + \delta_4 + \delta_5,$$

in which, δ_1 – fractional accuracy of determining the weight of the sample; δ_2 – fractional accuracy of determining the magnetic force affecting the sample; δ_3 – fractional accuracy of determining the magnetic field density at specified points of the operating area; δ_4 – fractional accuracy of determining $\frac{dH}{dx}$; δ_5 – fractional accuracy of determining approximate of the magnetic field in the operating area.

In all the experiments the sample weight changed within 5,43–5,85 g, fractional accuracy of a weight measuring device is 0,001 g, thus: $\delta_{1\max} = 0,00018$; $\delta_{1\min} = 0,00017$.

The magnetic force F_m affecting the samples changed within 0,037–0,35 g fractional accuracy of a weight measuring device is 0.001 g, therefore: $\delta_{2\max} = 0,027$; $\delta_{2\min} = 0,0028$.

The magnetic field density at specified points of the operating area (x_b, x_t) changed within 0,178-0,469 mTl, milliteslametre deviation is 0,001 Tl, thus: $\delta_{3\max} = 0,0056$; $\delta_{3\min} = 0,0021$.

Fractional accuracy of $\frac{dH}{dx}$ is defined as a sum of fractional accuracies of density determining (the same fractional accuracy occurs while determining intensity H) and fractional accuracy of determining coordinates of the operating area points,

Magnetic and power separation

hence: $\delta_{4_{\max}} = 0,0056 + 0,05 = 0,0556$; $\delta_{4_{\min}} = 0,0021 + 0,02 = 0,0221$.

The same deviation will be observed while determining the averaged density of the magnetic field in the operating area: $\delta_{5_{\max}} = 0,0056 + 0,05 = 0,0556$; $\delta_{5_{\min}} = 0,0021 + 0,02 = 0,0221$.

Summing up the deviations, we get the fractional accuracy of the whole experiment.

Moreover, the method deviation which is connected with the allowance made in formula (2) remains unaccounted. However, this deviation can be estimated by comparing the results of calculating χ using formula (3) and formula $\chi = \frac{F_m}{\mu_0 * Q}$ (4), in which, $Q = \rho \int_v H |grad H| dV$, in which ρ – the apparent density of the sample. In addition, under the integral sign in formula (4) we applied the disposal $H_{(x,r)}$ in the operating area found by experiment.

The deviation which occurred while calculating according to formulas (3) and (4) made up as maximum as 9%.

Conclusions

It has been determined that the manganese sludge samples are classified as feebly magnetic material. The magnetic susceptibility of the first sample ranges from 359 to $9 (*10^{-9} \text{ m}^3/\text{kg})$ while the magnetic field intensity varies from 64 to 262 kA/m. Meanwhile considerably increased magnetic susceptibility and its further reduction while increasing the magnetic field intensity are conditioned by ferromagnetic phase available in it. All this considered, while choosing magnetic separators and recovering iron-containing components it is necessary to make choice of separators with possibly lower level of magnetic density. The results of studying magnetic properties of magnetic crops of the material under research show their considerable difference in magnetic susceptibility for dressing initial sludges by dry magnetic separation techniques.

References

1. Karmazin V.I., Karmazin V.V. Magnetic dressing techniques. – M., 1978. – 23 p.
2. Svoboda Jan. Magnetic Techniques for the Treatment of Materials // Kluwler Academic Publishers. – 200. – P. 45-10.
3. Mladetskiy I.K., Kuvayev Ya.G., Lysenko A.A., Pavlenko A.A. Minimal sample mass for raw quality parameter analysis. – 2011.
4. Karmazin V.I., Mostyka Yu.S, Shutov V.Yu. and others. The analysis of the influence of magnetic saturation of highly gradient magnetic separation matrix and reducing magnetic susceptibility of extracted particles by means of the magnetic field intensity growth on magnetic separation efficiency. – M., 2000. – P. 221-223.
5. Vonsovskiy S.V. Magnetizm. – M., 1971.

© Zubarev A.I., 2013

*Надійшла до редколегії 13.09.2013 р.
Рекомендовано до публікації д.т.н. П.І. Піловим*