

“A MASTERLY THOUGH NEGLECTED WORK”,
BOSCOVICH’S TREATISE ON CONIC SECTIONS

ANDREA DEL CENTINA AND ALESSANDRA FIOCCA

A. Del Centina, A. Fiocca
Dipartimento di Matematica e Informatica, Università di Ferrara,
via Machiavelli 45, 44100 Ferrara, Italy
e-mail: andrea.delcentina@unife.it
corresponding author’s e-mail: alessandra.fiocca@unife.it

ABSTRACT. In this paper we describe the genesis of Boscovich’s *Sectionum Conicarum Elementa*, and discuss the motivations which led him to write this work. Moreover, by analysing the structure of this treatise in some depth, we show how he developed the completely new idea of “eccentric circle”, and derived the whole theory of conic sections by starting from it. We also comment on the reception of this treatise in Italy, and abroad, especially in England, where – since the late eighteenth century – several authors found inspiration in Boscovich’s work to write their treatises on conic sections.

SUNTO. In questo lavoro delineamo la genesi del *Sectionum Conicarum Elementa* di Boscovich, e discutiamo le motivazioni che indussero Boscovich a scrivere quest’opera. Inoltre, analizzando in dettaglio la struttura di questo trattato, mostriamo come egli sviluppò l’idea completamente nuova di “cerchio eccentrico”, e costruì partendo da questa nozione l’intera teoria delle sezioni coniche. Commentiamo anche sulla ricezione del suo trattato, sia in Italia che all’estero, specialmente in Inghilterra, dove – a partire dalla fine del diciottesimo secolo – vari autori si ispirarono all’opera di Boscovich per scrivere i loro trattati sulle sezioni coniche.

1 INTRODUCTION

In 1752, Boscovich published a textbook on planimetry and stereometry, the “vestibule of geometry” in his words,¹ which originated from his lecture notes for the courses he had given at the Collegio Romano as professor of Mathematics since 1740. It appeared in two volumes, without the name of the author, – and the reason for which will be made clear shortly –, under the title *Elementa Universae Matheseos* (Boscovich 1752). The first volume dealt with plane and solid geometry, arithmetic, logarithms, plane and spherical trigonometry, the second one with algebra, that is the theory of third and fourth degree equations, and the approximation of the roots of third order equations.² The spherical trigonometry had already appeared and included in (Tacquet 1745, II, 39-59).

During the printing of the work, Boscovich, who since July 1750 had been engaged in the task of measuring the meridian arc between Rome and Rimini together with his co-brother Christopher

¹ “... in ipso nimirum Geometriae vestibulo usi olim sumus” (Boscovich, 1754b, vii).

² See (Pepe 2010) for a more detailed description of the content.

Maire (1697-1767), was for long periods outside Rome.³ The scientific mission lasted until November 1752, when Boscovich returned to Rome. Some information about the printing job is given in the letter from Rome, dated February 22nd 1752, which Boscovich addressed to his elder brother Bőzo (Natale):⁴

Before I came back, a work of mine for the scholarly youth went to be printed; [?] the beginning of which I had written in Latin and was translated into Italian by Father Lazzari some years ago, and this version, the original being lost, was translated again into Latin by someone else. The work will be a mathematics course, of which this is the first volume containing plane and solid geometry, arithmetic, proportions, logarithms, plane and solid trigonometry, and algebra. But maybe the algebra will be separated and, instead of one [large] two small volumes will be printed. I re-worked the trigonometry, plane and solid, since my return here, and I did the same with all algebra at the end of my stay in Rimini, but I will touch up it.⁵

In the same letter Boscovich continued by saying that he was not satisfied with the content of the first volume printed in his absence, because “they are old things made for the mere use of students, not fit for printing, and they are poor”,⁶ and it was so that he decided not to put his name on the frontispiece. However, he was pleased with the other subjects, “even if”, he specified, “they were written among many economic, geographical and astronomical occupations”.⁷ He had also the time for adding an “Errata corrige” to both volumes.

In December 1752, Boscovich’s plan was to finish the redaction before the next Easter, so that a new volume, on the theory of conic sections, could be added to the first two of the *Elementa*.⁸ This would have been a treatise developed with purely geometrical tools, leaving the use of the analytical method to another book, in which he would have treated the applications of algebra to geometry. Such a project certainly conformed to the Jesuit tradition of maintaining separate synthetic and analytic methods, but, as will be seen later on, also it was due to the desire to adhere to Newton’s rejection of the Cartesian method.⁹

Nevertheless, something forced him to reconsidering his initial project. Most likely this was the discovery of the eccentric circle (see below), the tool through which he basically developed the theory of conics in the book, and the start of his dealing with the transformation of geometrical loci, which Boscovich decided it would be “convenient to add” to his treatise on conic sections. It was therefore, contrary to his plans, that only at the end of January 1754 could Boscovich announce to his brother Bőzo that the printing of the volume was almost concluded, and that it would be available in few days. This time Boscovich was very pleased with the result, even if it had cost him a “bestial fatigue”, as he wrote to Bőzo, “I can say that this is my first work made with full

³ Boscovich was outside Rome between October and December 1750, in the second half of 1751 he was traveling through Lazio, Umbria and Romagna. The two surveyors covered a cumulative distance of 2000 kilometres, up peaks as high as 1700 meters, carrying hundreds of pounds of equipment on horseback, in a really epic endeavour (Boscovich, Maire 1755; Pedley 1993).

⁴ In private Boscovich used to call his brother “Natale”.

⁵ Poco prima che io tornassi si era cominciata a stampare un’opera mia per uso della gioventù studiosa; [?] il principio della quale fatto da me in latino, era stato voltato in italiano dal P. Lazzari anni sono, e perduto il mio originale era stato di nuovo ritradotto in latino da un altro. Sarà quest’opera un corso di matematica, e questo è il primo tomo, in cui vi è la Geometria piana, e solida, l’Aritmetica, colle proporzioni, Logaritmi ecc. la Trigonometria piana, e sferica e l’Algebra, senonche forse l’Algebra la farà (sic) separare, e invece di uno far due tometti. Le due Trigonometrie le ho rifatte da che stò qui, e l’Algebra la feci tutta a Rimini sul fine, ma la ritoccherò. See (Boscovich 2012, 203).

⁶ See the letter addressed to Natale, dated Rome November 21st 1752, Ibidem, 217.

⁷ Ivi.

⁸ See the letter to Natale dated Rome, December 26th 1752, in (Boscovich 2012, 219).

⁹ For Newton attitude towards the Cartesian method see (Guicciardini 2011, Chapter 5).

attention, and I am sure that, because it contains several new things, it will have good sales and circulation.”¹⁰

The new edition in three volumes of the *Elementa Universae Matheseos* appeared in few months, with the third (Boscovich 1754), consisting of two parts, *Sectionum Conicarum Elementa* (1754a), where Boscovich entered the realm of “geometry which never operates by leaps”,¹¹ and *Dissertatio de transformatione locorum geometricorum* (1754b) specifically devoted to the principle of continuity and the transformation of curves, likely originating in his studies on the transformation of one conic section into another that he tackled when developing the first part.

In the preface to the reader of the first volume, Boscovich announced his intention to continue the work, with other volumes devoted to infinities and infinitesimals treated synthetically, the general properties of curves, the application of algebra to geometry, infinite series, the foundations of the differential and integral calculus, with their applications, and also mechanics, optics, astronomy, gnomonics, and the elements of mathematics useful in geography, chronology, architecture and music.

This ambitious program was not followed, and the work stopped with the third volume.

As we have already discussed the second part of the third volume of the *Elementa* extensively in (Del Centina, Fiocca 2018), we will concentrate here on the first part (Boscovich 1754a), which Charles Taylor defined a “masterly though neglected work” (1881, vi).

At the foundation of his work on conics, Boscovich did not put their definition as sections of a cone, but defined them in the plane; that is, a conic is the locus of points whose distances from a fixed straight line (directrix), and a fixed point (focus), are in constant ratio, that he called “ratio determinans”, that is *determining ratio*, and corresponds to the modern concept of eccentricity. Although the property of conic sections expressed by this definition was known to Pappus,¹² it was Newton who brought it fully to light in the *Principia*,¹³ a work which entered in the range of Boscovich’s interests in the late 1730s.

By means of this definition, Boscovich introduced into the study of conics a completely new tool, which constitutes the main feature of his work; precisely, a circle centred at any point outside the directrix whose radius equals the distance of the centre from the directrix times the determining ratio. By means of this circle, which was later called the *eccentric circle* (Taylor 1881, 3),¹⁴ Boscovich developed the whole theory of conic sections.

2 GENESIS OF BOSCOVICH’S *SECTIONUM CONICARUM ELEMENTA*

A new edition of Newton’s *Principia* (Newton 1739-42) by the two Minim Friars Le Seur and Jacquier,¹⁵ was published in Geneva in three volumes, the first of which appeared in 1739.¹⁶

¹⁰ See the letter to Natale dated Rome, [January] 22nd 1754, in (Boscovich 2012, 242).

¹¹ “Geometria, quae nihil usquam operatur per saltum” (Boscovich, 1754, III, xviii).

¹² See his *Mathematical Collections*, lib. VII, prop. 238 in (Pappus 1588, 303 versus).

¹³ See Lib. I sect. 4 and prop. 20 in (Newton 1687, 63) and (Newton 1707, 149). G. de S. Vincent (1647, prop. cxviii, 412) and P. de La Hire (1685, book VIII, prop. 3) knew this property in the case of parabola.

¹⁴ Following Taylor, we use this terminology, but other authors call it “generating circle” or even “auxiliary circle”.

¹⁵ Le Seur and Jacquier used the third edition of the *Principia* (Newton 1726).

¹⁶ For an analysis of this edition see (Bussotti, Pisano 2014; Guicciardini 2015).

This edition was very remarkable for the extensive footnotes that the commentators included in the text, aiming to facilitate the comprehension to non-expert geometers, of “such a high-level subject expounded by the more geometric brevity of the reasoning”.¹⁷ In this regard, we remark that the footnote inserted in the Scholium at page 115 of the first volume, is a little treatise of twenty pages on conic sections developed in the style of Apollonius.¹⁸

Thomas Le Seur (1703-1770) and François Jacquier (1711-1788) were two French mathematicians who belonged to the *Ordo Minimorum*. In the 1730s, they moved to Rome and in the French College of Trinità dei Monti, and they become “extraordinary actors of Roman cultural life” (Guicciardini 2015, 362). For sure Boscovich met Le Seur and Jacquier in the years they were working on the new edition of the *Principia*, and he had the opportunity to discuss Newton’s work with them, specifically the geometrical results contained in the first books.¹⁹ So it is not surprising that, shortly after the printing of the first volume of Le Seur and Jacquier’s edition of the *Principia*, Boscovich started to work on some subjects suggested by his reading of Newton’s work, and the notes added by the two Friars, in particular – as we will see – on the theme of the osculating circle, which he considered a concept not easy to grasp.

Boscovich also worked closely with Le Seur and Jacquier when, in 1742, the three mathematicians were asked by Pope Benedict XIV to study the stability of the dome of St. Peter’s (Boscovich, Le Seur, Jacquier 1742, 1743).

According to (Pepe 2016, 188), the Le Seur and Jacquier’s edition opened the way into Newton’s ideas into the Papal State, and, thought with circumspection, it was possible to write in Rome of mathematics and physics by adopting the methods of the *Principia*. On this route, which was not without obstacles, Boscovich put himself, and, as it will appear more clearly later, the third volume of the *Elementa Universae Matheseos* originated from his desire to write a work that would serve as an introduction to Newton’s *Principia*.

In the process of proving the law of central forces, Newton had been led to consider the notion of “curvature” of a curve at any point P . Newton developed this concept by applying the doctrine of the ultimate, or limiting, ratio, a method of investigation in geometrical problem much used by Newton, and whose logical foundation rests on the principle of continuity. He defined the *curvature* of a curve at a given point P on it as the reciprocal of the radius of the circle that, among all circles sharing the same tangent with the curve at P , approaches the curve “most tightly”,²⁰ see (Guicciardini 1999, 109-110). This circle, which was introduced independently by Newton and Huygens,²¹ was later called by Leibniz “circulus osculans”,²² and it is today known as *osculating circle*, or even *circle of curvature*.

¹⁷ See the *Monitum* opening the first volume.

¹⁸ These pages were written with the cooperation of the Swiss mathematician Jean Luis Calandrini (1702-1758), who also financed the publication, and took part in drawing up the footnotes which are marked with “*”.

¹⁹ The three mathematicians had also the opportunity to collaborate in 1742, when they were asked by Pope Benedict XIV to study the stability of the dome of St. Peter’s. The three mathematicians worked together on the problem, producing the relations (Boscovich, Le Seur, Jacquier 1742, 1743).

²⁰ In modern terms this means that the “intersection divisor” at P is $3P$.

²¹ See (Huygens 1673).

²² See (Leibniz 1686). Nevertheless, Leibniz erroneously believed that the “osculation” consisted in the coincidence of two contacts; that is, the intersection divisor was $4P$. This is not true in general, as it can be easily seen in a general point of a conic, but it is true at the both vertices of the transverse axis of the ellipse and of the hyperbola, and the vertex of the parabola.

The use of these concepts is evident in Lemma XI (book 1, sect. 2, of the *Principia*), see fig. 1a, and both had a central role in the proofs of the Propositions VI, X, and XI.²³

In the second proof of proposition X (book 1, sect. 2, of the *Principia*, which Newton added to the second edition (1713) of the *Principia*), Newton considered two points, P and Q , on a conic section, the tangent to the conic at P , the diameter PG , and the conjugate diameter DK (fig. 1b). Then, from Q he drew the parallel Qv to the tangent, and the perpendicular QT to the diameter PG . Next he considered the point u on PG , on the opposite side of v with respect to T , so that $Tu = Tv$, and chose V , on PG , so that $uV : vG = DC^2 : PC^2$. Newton observed that under this conditions, the circle which is tangent to the conic at P and passes through Q , also passes through V . When the point Q approaches the point P , also the points u, v approach P , and since $uV : vG = DC^2 : PC^2$, at the limit one has $PV : PG = DC^2 : PC^2$. This means that the chord PV that the osculating circle cuts on the diameter PG is equal to $2 \times DC^2 / PC$. This identifies the osculating circle.

Newton's very concise geometrical arguments were clarified by Le Seur and Jacquier in the footnotes they included in the first volume of (Newton 1739-42).²⁴ Going deeply into Newton's results, and by following Apollonius' *Conics* step by step, they showed how to find the radius Pr of the osculating circle to a conic at the given point P . For the ellipse, and the hyperbola, they obtained $Pr = CD^2 / PF$, where CD is the half of the conjugate diameter of the diameter through P , and PF is the normal from P to that diameter (fig. 1b). Then, for any conic section, they deduced that $Pr = 4PK^3 / L^2$, where L is the principal latus rectum and K is the intersection between the perpendicular to the tangent to the conic at P and the transverse axis.²⁵

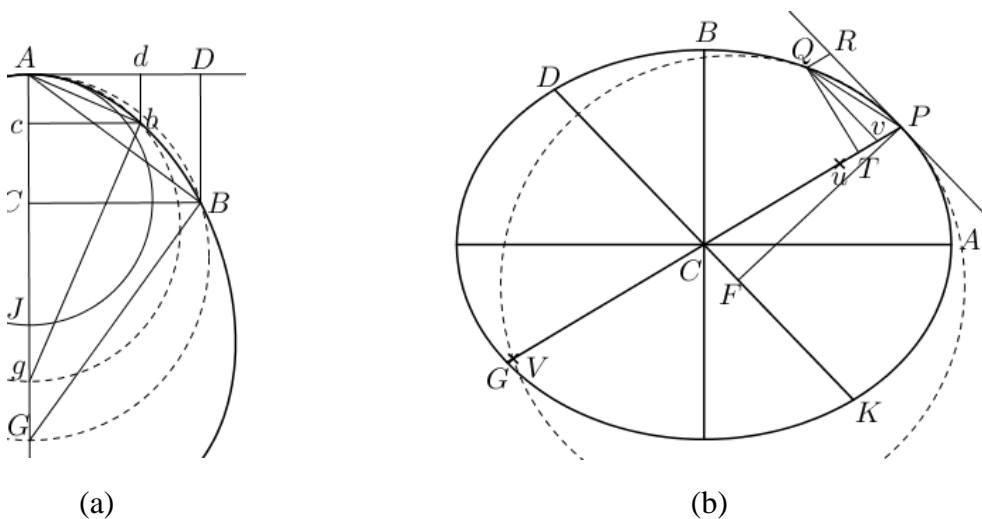

Figure 1 (a) Newton's figure for lemma XI. Newton considered the circles ABG, Abg (but without drawing them), which share the same tangent at A with the curve AbB . When B and b approach A , then G and g approach J , which is their limiting position. AJ is the diameter of the osculating circle. (b) Enhanced version of Newton's figure for the proof of the proposition X, (book 1, sect. 2, *Principia*), with the addition of the circle which is tangent to the conic at P , and also passes through the point Q lying on the conic.

In section 3 of the first book of the *Principia*, though in an indirect way, Newton had also used the concept of *latus rectum* pertaining to a diameter of a conic section, already known to Apollonius. This notion extended that of latus rectum, as the segment equal to the focal chord orthogonal to the axis, for which Newton had reserved the name of *latus rectum principale* (principal latus rectum).

²³ See for instance (Brackenridge, Nauenberg 2002).

²⁴ See (Newton 1739-42, I, 140, note (e); 141 note 230).

²⁵ See (Newton 1739-42, I, 144, note 239).

Curvature and latus rectum were also explicitly defined by Le Seur and Jacquier in their footnotes. In the ellipse and in the hyperbola, the latus rectum pertaining to a given diameter is the third continuous proportional after the diameter and its conjugate; that is, the square of the conjugate divided by the diameter itself.²⁶ In the parabola, the latus rectum is the third continuous proportional after the abscissa (pertaining the diameter) and the corresponding semi-ordinate; that is the square of the semi-ordinate divided by the abscissa.²⁷ In the last case, the latus rectum corresponds to the focal chord parallel to the tangent at the vertex of the diameter, whose length always is 4 times the distance of that vertex from the focus.

A year after the publication of the first volume of the edition of the *Principia* by Le Seur and Jacquier, Boscovich published a booklet entitled *De circulis osculatoris dissertatio* (1740), in which he dealt with this topic. In the introduction, likely because he was not completely satisfied with the explanations given by Le Seur and Jacquier, he wrote:

How necessary in these times is the knowledge of the osculating circles is well recognized by those who devote themselves to describe this recent very important invention, as well by those who apply their intelligence in investigating the mysteries of nature. It is not so easy to conceive the correct idea of them [the osculating circles], so, to ensure that the less cautious geometer does not make errors, it is necessary that the most excellent men will sooner or later explain them. The aim of this dissertation is exactly this.

Boscovich therefore felt the need to clarify this important concept. In Art. II, he defined the osculating circle to a curve at a point P as the circle C that, sharing the same tangent at P with the curve, is such that a small arc around P of any other circle touching the curve at that point lies entirely inside, or outside, the curve, according to its radius is less, or greater, than that of C . Next, in Arts. III-XI, Boscovich proved that: *if a circle sharing the same tangent with the conic at a point P , is such that on the diameter of the conic passing through P intercepts a chord equal to the latus rectum pertaining to that diameter, then it osculates the conic at P .*²⁸ This is the converse of Newton's claim.

Boscovich developed in detail the case of the hyperbola, whose proof extends for almost four pages, and remarked that the other cases could be treated similarly. Here we briefly present his argument, that he took up also in the *Elementa*. The proof required some premises.

Let eBE be a conic section (fig. 2a), DB a diameter, eME an ordinate parallel to the tangent HBP at B , and BP equal to the parameter pertaining to the diameter. Boscovich observed that if the diameter is not an axis, then BME is an acute angle, and BMe an obtuse angle. Then he produced the ordinate until it intersects DP at F . From the properties of the conics one has $ME^2 = Me^2 = BM \times MF$, and MF is greater, equal, or less than BP according to the conic is a hyperbola, a parabola, or an ellipse.

²⁶ (Newton 1739-42, I, 122, 127).

²⁷See (Apollonius 1566, I, prop. 20, 21, 49, 50), (Apollonius 1896, proposition 22 (I, 49)), also (Newton 1967-81, VI, 145 (119)). The latus rectum, or parameter, pertaining to any diameter of a conic section is explicitly defined in [La Hire 1685, 45-46]. We stress that Newton had read La Hire's *Sectiones Conicae*, and in fact he referred to it in the last scholium in section 4 of book I of the *Principia*, see later on. We also notice that the same definitions appear in the account on conic sections inserted in (Guarini 1671, 394-395).

²⁸ This result is implicitly claimed in Newton's proposition X.

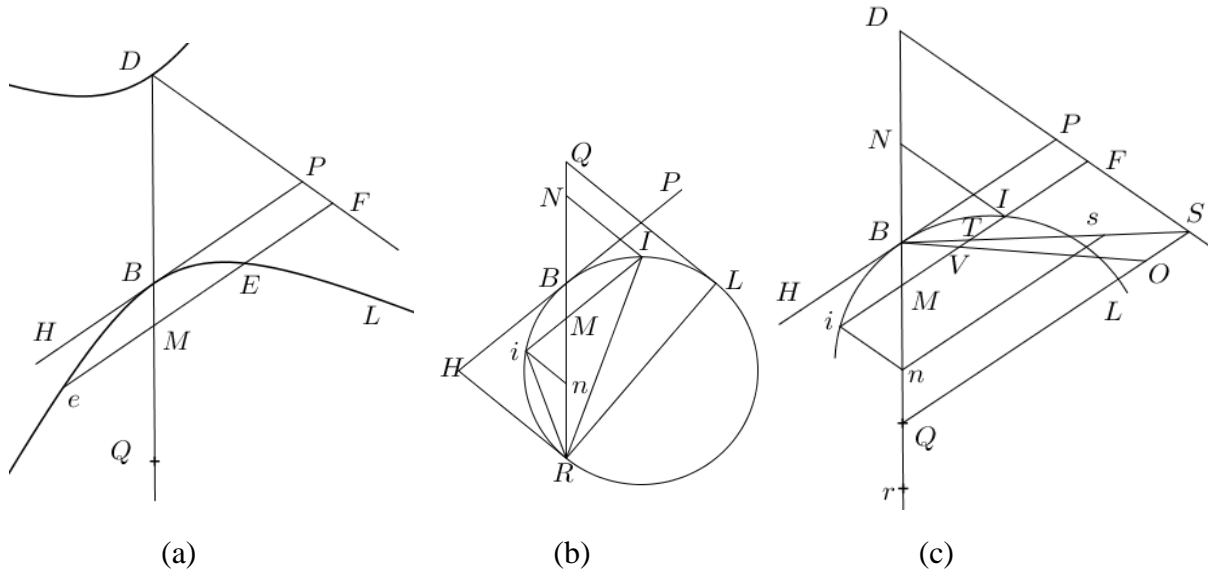

Figure 2 (a), (b) and (c) are respectively Boscovich figures 1 (the case of the hyperbola), 4 and 5 in (1740).

Afterwards, Boscovich considered a circle BLR (fig. 2b) which shares the same tangent with the conic section at B , and cuts on the diameter through B the chord BR , he drawn a chord IMi parallel to the tangent, which intersects the diameter at M , and observed that MI lies in the obtuse angle \widehat{RBP} , and Mi in the opposite acute angle \widehat{RBH} . If IN , and in , are drawn parallel to the tangent RH to the circle at R , one has $\widehat{BMI} = \widehat{BNI}$ and $\widehat{iRM} = \widehat{MRI}$, then, by similarity of triangles, $MI^2 = BM \times RN$ and $Mi^2 = BM \times Rn$. If BR is a diameter of the circle, one has $MI^2 = Mi^2 = BM \times MR$, otherwise always is $RN > Rn$, hence $BM \times RN > BM \times Rn$ and $MI > Mi$. Moreover, let BQ equal to the parameter BP (fig. 2c), and drawn QS parallel to BP , it is readily seen that $BP : TF = PS : FS = BQ : MQ$, which yields to $TF = MQ$.

At this point Boscovich wrote, “Having premised all this it is easy to prove that the circle which cuts on the diameter the chord BR equals to BQ , osculates the hyperbola at B ”.

He first assumed BR is less than BQ . In this case, if N is taken so that $NB < RQ$, and the construction as in fig. 2b is performed so that the chord iMI is determined, it follows that $RN < BQ = BP < MF$. Then one has $MI^2 = BM \times RN < BM \times MF = ME^2$, and therefore the point I lies inside the hyperbola with the whole arc IB . Moreover, being MI greater than Mi , also the point i lies inside the hyperbola, with the whole arc Bi .

Then he supposed the chord Br (fig. 2c) greater than BQ . In this case, let the point n be so that $(BQ + QS)$ is to BQ as Qr is to Bn , drawing ni parallel to the tangent at r to the circle and iMI , ns parallels to the tangent at B , one sees that $Qr = Bn + ns$. Now, since

$$nr = Br - Bn = Br - Qr + ns = BQ + ns = BM + MQ + ns = BM + TF + ns > MF,$$

and nr increases, as n moves toward B from its initial position the inequality $nr > MF$ continuously holds until n reaches B . Because from above $Mi^2 = BM \times rn > BM \times MF = Me^2$, it follows that the inequality $Mi > Me$ continuously holds, thus the whole arc iB lies outside the hyperbola, and even more so, for what was said above, IB will lie outside the hyperbola. “Therefore”, concluded Boscovich, “the circle which has the same tangent as the hyperbola and intercepts a chord equal to the parameter, is the osculating circle”. In the *Elementa*, Boscovich will take this property as definition of the osculating circle.

In Art. XVIII, Boscovich explicitly quoted Newton; precisely he referred to Newton's last scholium in the first section of book 1 on the method of limiting ratio and the geometrical continuity. Finally, in Art. XIX, he gave a list of four results regarding the osculating circle. For example: the centre of the osculating circle to the curve at P is the limiting position of the intersection point of the normal to the tangents to the curve at points P and Q , when Q tends to P .

In the two years after the publication of the booklet on the osculating circle, Boscovich was concerned with various analytical questions (the nature and use of infinitely great and infinitely small quantities), astronomical problems, and, as already mentioned, the study the stability of the dome of St. Peter's. In two papers of 1743 and 1744, he took up some themes of sections 3 and 4 of the first book of the *Principia*.

In the dissertation *De Motu Corporis attracti in centrum* (1743), Boscovich in order to present a proof of the direct and inverse problem of central forces, started by defining a conic section by its directrix, focus, and determining ratio (paragraph XXIII). Thereafter, Boscovich was to adopt this definition in treating conic sections. He preferred to use this definition, "as de L'Hospital,²⁹ and others have already done", certainly inspired by Newton, "a man of great learning, who demonstrated elegant theorems, and solved very difficult and most important problems in mechanics, as the fruit of Geometry, whose traditional methods he used magisterially", as he wrote in the introduction, referring to the geometrical results contained in the *Principia*. In fact, it was in the scholium to the proposition XXI that Newton, on tackling the problem of determining the trajectory (that is the conic), given its focus S , and three of its points B , C , and D (see fig. 3b), determined the directrix EF (without giving it any name) by choosing E and F , respectively on the straight lines BC and CD , so that $EB : EC = SB : SC$ and $FC : FD = SC : SD$, and the vertex is the point A , on the perpendicular to EF passing through S , for which $GA : AS = HB : BS$.

After the proof, Newton remarked that the "clarissimus geometra de La Hire", with a not very dissimilar method, had found a solution to the same problem in his *Conics* (book viii, prop. xxv).³⁰

In the dissertation mentioned above, Boscovich, anticipating some typical expressions he was to use later on in the *Dissertatio de transformatione locorum geometricorum* and by referring to the principle of continuity,³¹ observed that when the directrix moves to infinity the conic becomes a circle centred at the focus, in fact he remarked, "the ratio of the distances of two points on the (initial) conic from the directrix, and the ratio of their distances from the focus, both tend, beyond any limit, to a ratio of equality [i.e. 1]".

Afterwards, he proved a corollary (paragraph XXIV) that was to have an important role in Boscovich's future approach to conic sections: *suppose the chord AB meets the directrix ER at E, let E be joined with the focus F and from A be issued the parallel to EF, then, if H is the point in which this parallel intersects the focal ray FB, one has FA = FH* (fig. 3a). The proof goes as follows.

²⁹ See (L'Hospital 1707).

³⁰ Newton was referring to (La Hire 1685).

³¹ See for instance (Del Centina, Fiocca 2018).

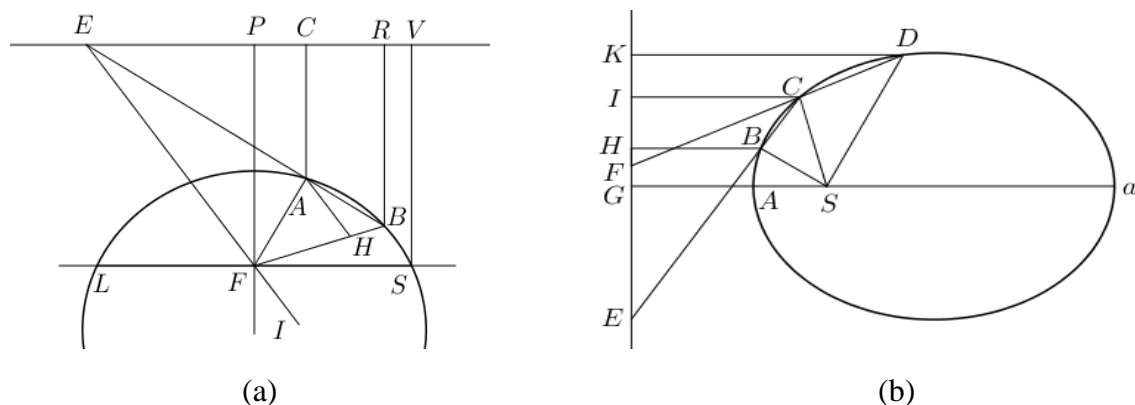

Figure 3 (a) Boscovich’s figure 4 in *De Motu Corporis etc.* (1743). (b) Newton’s figure in the scholium to the proposition XXI (*Principia*, book 1). Here $GA : AS = HB : BS = IC : CS$.

From $FB/BR = FA/AC$, by permuting and taking into account the similarity of the triangles ERB and ECA , it follows that (1) $FB : FA = BR : AC = BE : AE$, then from the similarity of EBF and ABH one has $EB : AB = FB : HB$, therefore $(EB - AB) : EB = (FB - HB) : FB$, which implies (2) $EA : EB = FH : FB$. Thus, from (1) and (2), one gets $FB : FA = BR : AC = BE : AE = FB : FH$, that is $FA = FH$.

In paragraphs XV—XXVII, Boscovich developed a number of geometrical results as consequence of the above corollary. For instance, the determination of the directrix of a conic when is given one focus and three points of the conic itself (this is Newton’s scholium to the proposition XXI recalled above), and the determination of the tangent at any point of the conic.

In 1744, Boscovich, now 33 years old, having completed his theological studies, and having passed the doctorate examination, was ordained as a priest. By this time, he had already written more than twenty scientific works, and several poems in Latin. The same year, he was elected a member of the Accademia dell’Arcadia.³² Boscovich continued his reading of the *Principia*, as the motto “Ad exercendam Geometriam, et promovendam Astronomiam”,³³ that he added to the title of his *Nova methodus adhibendi phasium observationes in eclipsibus lunaribus* (Boscovich 1744) also suggests.

In Art. 16 of this paper, Boscovich stated a theorem to which he referred as “the very well-known theorem, by which many problems, at first glance difficult, can be solved easily”; that is, the chords theorem for the conic sections, which was to have a fundamental role in Boscovich’s approach to the theory of these curves. Newton, by quoting the propositions 17, 19, 21, and 23 in Apollonius’ *Conics*, book 3, had mentioned this theorem indirectly in the course of his proof of lemma XVII (*Principia*, book 1, sect. V). For the use Newton made of it in the lemma, and in the subsequent results, the substance is (fig. 4a):³⁴ *if any two chords AB and PK of a conic section intersect each other, then, denoting by Q their intersection point, the two rectangles AQB and POK are in given ratio which does not change when the two chords are moved parallel to themselves.*

This can be rephrased to say that the ratio $(AQ \times QB) / (PQ \times QK)$ depends only on the directions of two straight lines AB and PK .

³² The *Accademia* was founded in 1690 with the aim to cultivate the sciences and to awaken good literary taste. In twenty years from its foundation, the Academy counted almost one thousand three hundred members, among whom there were cardinals, princes and prelates, but also dames (Crescimbeni 1711).

³³ “To cultivate Geometry, and promote Astronomy”.

³⁴ See (Newton 1739-42, lemma XVII, sect. V), and footnote (y). This means that the ratio does not change if the chords are moved parallel to themselves.

In Apollonius' *Conics*, the proof of this theorem, which requires several preliminaries, is given in the proposition 17 of the third book, but in the case of the hyperbola only one branch of it is considered. In the subsequent six propositions other cases for the two branches of the hyperbola and also the conjugated hyperbola, are solved.³⁵ In the papers of Newton, for his part, an algebraic proof of the theorem can be found.³⁶

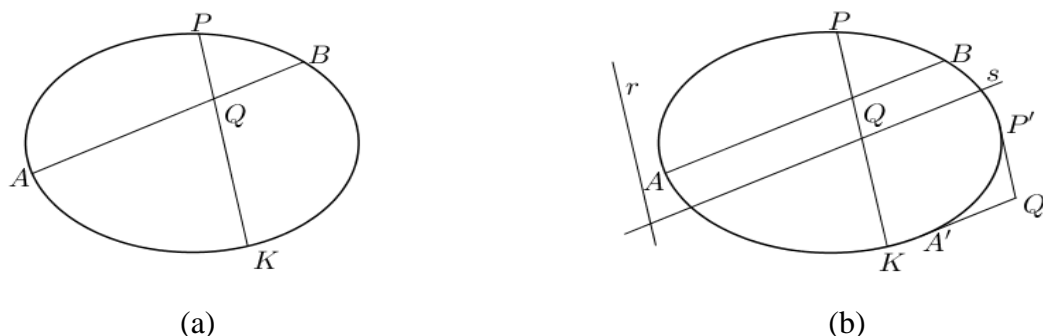

Figure 4 (a) Deduced from Newton's figure for lemma XVII (*Principia*, book I, sect. V). (b) Deduced from Boscovich's statement in (1744, Art. 16). Let AB, PK two chords respectively parallel to the straight lines s, r given in direction and let $A'Q', P'Q'$ two tangents to the conic respectively in points A' and P' , and respectively parallel to the straight lines s, r , then $(AQ \times QB) / (PQ \times QK) = P'Q'^2 / A'Q'^2$.

The theorem allowed Newton to prove several propositions regarding conic sections, among the most important we count: the synthetic solution of the Pappus problem of four lines (lemma XIX), which also gave him the key to complete the theory of central forces (planetary motion), and the construction of the conic section which passes through $5 - n$ given points and touches n straight lines given in position, $n = 0, 1, \dots, 5$ (prop. XXII-XXVII).³⁷

Newton's results attracted the attention of mathematicians to the chords theorem, and, after him, this theorem was considered one of the most outstanding in the theory of conics sections. The Marquis de L'Hospital, around 1700, realized the fundamental importance of the chords theorem, and claimed that "all other properties of conic sections depend on it", as reported in (Le Poivre 1708, preface). James Stirling in the work *Linæ Tertii Ordinis Neutoniana* (1717, 122-123), published an algebraic proof of the chords theorem based on the simple observation that the term of degree zero in an algebraic equation in one variable, is the product of the roots of the equation itself, times the coefficient of the term of maximal degree.³⁸ At the end of the proof, renewing de L'Hospital's belief, Stirling added "Through many corollaries of this propositions flows the whole of conic sections".

In (1744, Art. 16), Boscovich stated the theorem in the form (fig. 4b): *If two straight lines, parallel to other two straight lines of given direction, intersect each other and the conic section, the rectangles under the parts between the common point and their respective intersections with the conic are in given ratio; and when the two intersections of each with the conic coincide, so that the*

³⁵ See (Apollonius 1959, 210-223).

³⁶ Newton knew the theorem since the end of the 1670s, (Newton1967-81, IV, 358-359).

³⁷ J.J. Milne (1927, 96) remarked that when the law has been established that the orbit of a planet is a conic section described under the action of a force situated at the focus, two kinds of problems arise: to describe an orbit having given the focus and three other conditions, and to describe an orbit satisfying five conditions, when the focus is not given. The two problems are solved by Newton respectively in sections IV and V.

³⁸ This is substantially the proof found in Newton's manuscripts, see (Newton 1967-81, IV, 358-359).

secants become tangents, the squares of the tangents substitute the rectangles. Afterwards, he applied this to get a series of corollaries regarding the hyperbola, which he needed in the study of lunar eclipses.

In Art. 31, Boscovich for the first time expressed his intention to write a treatise on conic sections:

Since the properties of the hyperbola, as well those of the ellipse and of the parabola, cannot only be deduced from the solid, that is from the section of the cone, but more elegantly from their consideration in the plane... Thus, in compiling the elements of conic sections, we will follow the method of the noble Hospital, who first defines these curves in the plane,³⁹ and then proves that they arise from the sections of the cone.

Clearly, Boscovich aimed to follow de L'Hospital's approach by defining the conics in the plane, but – adhering to Newton's setting – through the synthetic method rather than the analytic one.

To explain his idea better, he added:

As we hope, we will publish these elements in a very near future, but they will be not similar to the work of L'Hospital, because another definition (of conics) will be assumed, of which last year we showed the extreme usefulness in the solution of very difficult problems. By means of this definition, and with a new and easy geometrical method, all things descend, the properties of diameters, foci, tangents, asymptotes of the hyperbola, and even that same theorem.

Thus, in composing his book, Boscovich wanted to put the chords theorem in a distinguished position. Moreover, to illustrate the force of this theorem, he showed in Art. 33 – following Newton – how to draw the conic passing through five given points, or passing through four points and tangent to a straight line given in position.

3 THE ANTICIPATORY ARTICLE OF 1746

In his paper (1746), Boscovich presented a direct synthetic proof of the chords theorem, and anticipated how his treatise on conic sections would develop. The occasion to write this article was given by one of the Editors of the *Giornale de' Letterati*, presumably Giacomelli,⁴⁰ who, as is said in the Editor's introduction, asked Boscovich for a geometrical proof of the chords theorem, “a theorem”, he pointed out, “from which, according to Stirling, a new way of dealing with the whole theory of conic sections could be derived”. It was most likely Boscovich himself who promoted the publication of the article. In the same introduction, the Editor quoted (Stirling 1717), in which the “author had proved the theorem analytically in a beautiful and simple way”. Next, he recalled that the theorem was known and could be found in various treatises, but only proved after a series of preliminaries, so that its proof resulted “very long and complicated”.⁴¹

Boscovich picked up the invitation also because, as we read in the same introduction, he had long since obtained a proof, directly derived from the definition of conic section by directrix, focus, and

³⁹ De L'Hospital defined the parabola by directrix, focus and determining ratio, while ellipse and the hyperbola respectively as the locus of points such that the sum, or the difference, of the squares of their distances from the foci is constant.

⁴⁰ Michelangelo Giacomelli (1695—1774), was an erudite priest who was very influential in Rome around the middle of the eighteenth century. He maintained a scientific correspondence with Guido Grandi, and, in 1745, he became co-editor (with Gaetano Cenni) of the *Giornale de' Letterati* founded in 1742.

⁴¹ Geometrical proofs of the chords theorem developed with the method of projection, that is in the space, had appeared in (Guarini 1671; Le Poivre 1704; L'Hospital 1707, chap. 6), but no simple proof “in the plane” was known.

determining ratio, with the aid of an elementary lemma. This was also an opportunity to illustrate the treatise he was working on concerning conic sections, in which the main properties of these curves were to have been deduced from that theorem.

Directly from the definition Boscovich obtained the following important corollary (see fig. 5): *Let a conic be defined by the focus F and the directrix PA , and let B be a point on the conic, then the ratio between FB and BA , A being the point where a straight line of given direction passing through B intersects the directrix, only depends on the direction of that straight line.*

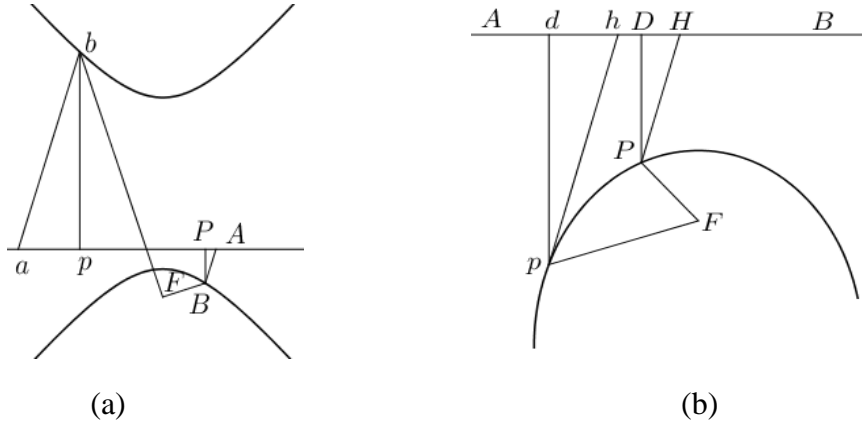

Figure 5 (a) Boscovich's figure 1 in (1746), the horizontal line is the directrix, and F is a focus of the hyperbola. (b) Boscovich's figure 1 in (1754a).

Let P be the foot of the perpendicular from B on the directrix. Since the ratio FB/BP is constant for any point B on the conic and the ratio BP/BA depends only on the direction of BA , from $(FB/BA) = (FB/BP) \times (BP/BA)$ it follows that the first ratio depends only on the directions of BA .

He also proved the lemma: *Let DPE , an isosceles triangle of basis DE , and let F be a point on the basis, or on its prolongation, then the rectangle DFE equals the difference between the squares of PE , PF .*⁴²

From these two facts, Boscovich obtained the chords theorem (Theorem 1), stated here in the form (fig. 6): *Let a conic be given by directrix, focus, and given ratio, and let BC , bc two chords intersecting in P , each of fixed direction, then the ratio $(BP \times PC) : (bP \times Pc)$ is constant.*⁴³

To prove it Boscovich argued as follows. Denoting A , a , the points where the straight lines BC , bc , respectively met the directrix, Boscovich drew from P the straight lines PD , PE parallel to the straight lines FC , Fb respectively, D and E being the points where these parallels meet the straight line FA . Then he issued from P the straight lines Pd , Pe parallel to Fc , Fb respectively, d and e being the points where these parallels meet the straight line Fa . Finally, he drew BG parallel Pa . Then, from the parallelisms $FB//PE$ and $FC//PD$, and from the corollary it results that $PE : PA = FB : BA = FC : CA = PD : PA$, hence $PE = PD$. Therefore, from the lemma applied to the triangle DPE it follows that $EF \times FD = PE^2 - PF^2$, and $EA \times DA = PA^2 - PE^2$. Similarly it can be seen that $Pd = Pe$; then, again for the lemma applied to the triangle dPe , one has $eF \times Fd = Pe^2 - PF^2$, and $ea \times da = Pa^2 - Pe^2$. From $EP//FB$, $Pa//BG$ (G being the intersection point between the parallel to

⁴² In the first case the proof immediately follows from Euclid's *Elements* prop. 5 book 2, and in the second from prop. 6 same book. In the following, we will use the formula $DF \times FE = PE^2 - PF^2$, by supposing $PE > PF$, otherwise the sign has to be changed.

⁴³ "Si binae rectae CB , cb , fig. 3 & 4, datam semper inclinationem habentes sibi invicem occurrant in P , & sectioni Conicae illa in B , C , haec in b , c ; erit rectangulum BPC ad bPc in ratione data" (Boscovich 1746, 191).

Pa from B and the directrix), $Fb//Pe$, and the corollary, it follows that $EP : PA = FB : BA$, $PA : Pa = BA : BG$, $Pa : Pe = ba : bF = BG : BF$, and therefore $EP : Pe = FB : BF$ which implies $PE = Pe$. Hence $EF \times FD = eF \times Fd$. Moreover, from the parallelisms $FB//PE$ and $FC//PD$ one also has $PB : FE = PA : EA$, $PC : FD = PA : DA$. Hence

$$(PB \times PC) : (FE \times FD) = PA^2 : (EA \times AD) = PA^2 : (PA^2 - PE^2),$$

but, since $PA/PE = BA/FB$ depends only on the direction of BC , also the first ratio depends only on the direction of BC . Similarly it can be seen that $(Pb \times Pc) : (Fe \times Fd) = Pa^2 : (Pa^2 - Pe^2)$. Now, since also Pa/Pe depends only on the direction of bc , one concludes that $(BP \times PC) : (bP \times Pc)$ depends only on the directions of Bc and bc , and this prove the theorem.

This proof certainly would have pleased Newton.

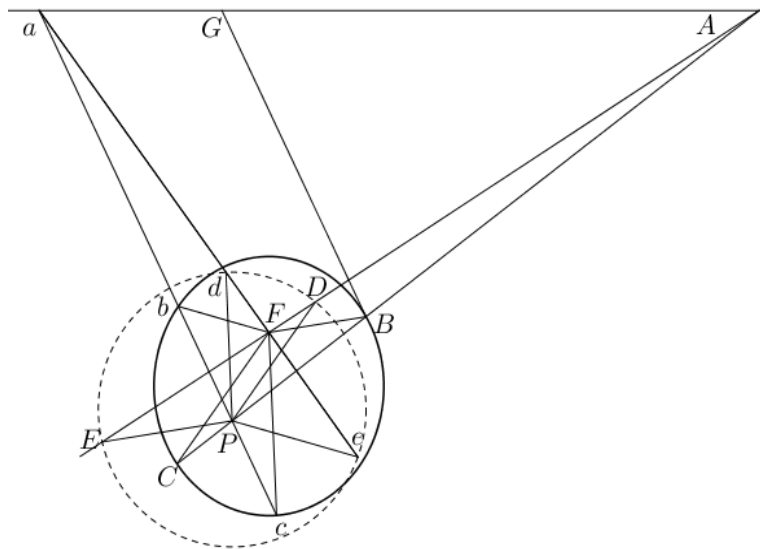

Figure 6 Enhanced version of Boscovich's figure 4 in (1746), with the addition of the circle (dashed line) centred at P and passing through the points D, E, d , and e , illustrating the proof of the chords theorem.

The discussion continued through four corollaries. In the first of these Boscovich determined the value of the constant ratio which forms part of the chords theorem as a function of the sine of the angles that the two chords form with the directrix. In the third, he observed that if the points B and C coincide, the secant becomes tangent to the conic, and instead of the rectangle CPB the square of the tangent has to be considered, and, at the same time, points D and E also coincide.⁴⁴

Afterwards, in scholium 2, Boscovich wrote:

We add some theorems from which we can understand how easy it is to deduce from the definition itself [definition 1], and theorem 1 above, all the properties of conic sections; however, we will refer to only a few of them, without treating the many propositions which follow, because all these will be exposed in [my] Elements of Conic Sections.

⁴⁴ Boscovich wants to say: If the chord BC moves parallel to itself and becomes tangent to the conic at a certain point X , then $CPB : bPC = P'X^2 : bP'c$, being P' the point of intersection of the tangent with the chord bc . Boscovich applies the geometrical continuity in the form of "the principle of permanence of functional relations", see (Del Centina, Fiocca 2018). Boscovich will use this remark in the proof of theorem 4.

Boscovich stated and proved four theorems, which he numbered from 2 to 5, with several corollaries and scholia, which covered a large part of the theory of conic sections. In the following, for brevity, we give the proofs of theorems 2 and 4 only, which will suffice to give an idea of Boscovich’s use of the chords theorem, and we will summarize what remains.

According to Boscovich, a *diameter* of a conic section is any straight line that bisects two parallel chords (the chords are called *ordinates* with respect to that diameter). He first showed that any other chord parallel to them is bisected by the same diameter; then, as theorem 2, he proved (see fig. 7a): *the square of a semi-ordinate equals the rectangle given by the segments intercepted by the chord on the relative diameter*, in the ellipse and in the hyperbola, that is $CE^2 = AE \times EB$. To show this he proceeded as follows. Let CD and FK be two parallel chords, which are bisected by the diameter AB respectively at E and H . Suppose LP be another chord parallel to CD and FK , which AB cuts at N . First, one has to show that $LN = PN$. Having drawn the straight lines CQ and DR parallel to EH , which intersect FK , and LP , respectively at G and I , and M and O , one has $HG = HI = EC = ED$ and, since $FH = HK$, it follows that $FG = IK$, hence the rectangle FGK equals the rectangle KIF . Therefore, by theorem 1, the rectangle CGQ equals the rectangle DIR , and, since $CG = DI$, one has $GQ = IR$ and also $CQ = DR$, which implies that the rectangle CMQ is equal to the rectangle DOR which in turn, again in accordance with theorem 1, implies that the rectangle LMP is equal to the rectangle LOP . Then, $NM^2 = EC^2$ and $NO^2 = ED^2$, hence $NL^2 = NP^2$, that is $NL = NP$ as required. From here it follows that $NP^2 : BNA = DE^2 : AEB$, that yields $PNL : CED = ANB : AEB$ as required.

In the subsequent scholium, Boscovich claimed that it is easy to prove that in the ellipse, and in the hyperbola, all diameters pass through the same point (the *centre*), while in the parabola all diameters are orthogonal to the directrix. It is interesting to notice that the case of the parabola is reduced to that of an ellipse “infinitely elongated”, since (fig. 7a) “when B goes to infinity, the ratio $NB : EB$ tends to the ratio of equality [i.e. 1], and then the rectangle BNA is to the rectangle BEA as NA is to EA ”. Thus, in order to deduce the properties of one conic section from another, Boscovich had already applied geometrical continuity. In the subsequent four corollaries Boscovich proved, among other things, that the parallels to the ordinates at the extremities of a diameter meet the conic only in those points (corollary 1), defined the transverse and conjugate axis of the ellipse and of the hyperbola, and showed the symmetry properties of these curves, as well as the existence of another focus, and another directrix, for them.

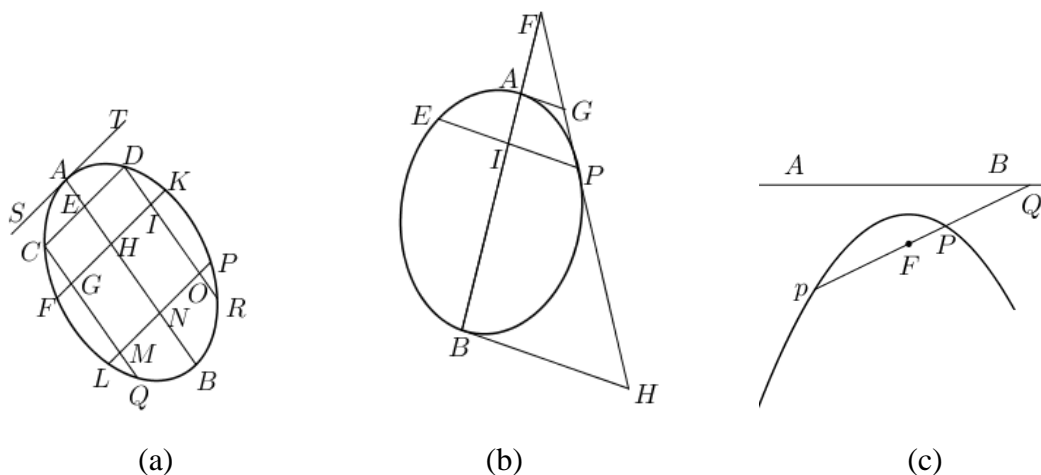

Figure 7 (a) Boscovich’s figure 8 in (1746), proof of theorem 2. (b) Boscovich’s figure 14 in (1746), for the proof of theorem 4. (c) Boscovich’s figure 3 in (1754a).

Then in the scholium 2, still resorting to theorem 1, he proved that any focal radius to a point A of the curve is orthogonal to the straight line joining the focus F to the intersection point of the directrix with the tangent to the conic at A .

With theorem 3, Boscovich showed that for any point of an ellipse the sum of the distances from the foci equals the transverse axis, while for the hyperbola it is the difference which is equal to the transverse axis,⁴⁵ and in both cases, the focal radii to any point of the conic form equal angles with the tangent to the conic at that point. In the subsequent scholium he claimed that the tangent to a parabola at any of its points form equal angles with the focal radius and the parallel to the transverse axis through that point.⁴⁶

In theorem 4 (see fig. 7b), Boscovich proved that: *the ordinate and the tangent at the same point of a conic section, cut the diameter, or its prolongation, in the same ratio, that is $AI:IB = AF:FB$* . For, having drawn from A and B the parallels to the chord EP , which, by corollary 1 to theorem 2, are tangent to the conic at A and B , and let G and H be their intersection with the tangent at P . By theorem 1, one has $GP^2:GA^2 = PH^2:HB^2$, hence, by alternating and dividing, it follows that $GP:PH = GA:HB$, but $GP:PH = AI:IB$, and $GA:HB = AF:FB$, and the claim is proven.

In the subsequent scholium, Boscovich claimed that for the parabola, in which case the vertex B is at infinity, the equality $AI = AF$ holds true.

Finally, with theorem 5, he defined the *asymptotes* of the hyperbola, and established their properties. In the subsequent scholium, closing the article, Boscovich stated that for every straight line which intersects the asymptotes of a hyperbola at M, m , and the curve in N, n , one has $MN = mn$. In the proof he again used the principle of continuity.⁴⁷

In 1746, Boscovich seemed to have developed a substantial part of the designed treatise on conic sections, but, he had not yet grasped the idea of the eccentric circle, and its discovery would later convince him to change the setting. This, together with the desire to develop a theory of geometrical continuity – which arose with his studies on conic sections – were among the reasons causing the delay with which the treatise appeared, with respect to Boscovich’s original plans. In those six years Boscovich was also involved in many other questions regarding tides, optics, geodesy, and, as already said, in measuring the meridian arc between Rome and Rimini.

4 THE SECTIONUM CONICARUM ELEMENTA

Before entering into a detailed analysis of Boscovich’s treatise, through a discussion of the main theorems he proved therein, we will give a brief description of its contents and how he organized it.

4.1 Style, organization, and content of Boscovich’s treatise on conics

As we learn from the introduction of the *Elementa*, apart from the analytical method – which Boscovich rejected, as Newton had done –, there were two ways to develop the theory of conics, one through the sections of a cone, and the other by their definition in the plane. According to Boscovich, the first route required a long preparatory work before entering into the matter, so he

⁴⁵ The diameter perpendicular to the directrix is called transverse axis, and the diameter parallel to the directrix is called conjugated axis.

⁴⁶ In the case of the parabola, the straight line perpendicular to the directrix through the focus is called transverse axis.

⁴⁷ We notice that the argument used here is questionable, and, in fact, in *Sectionum Conicarum Elementa* Boscovich proved this result in another way, see cor. 6 to prop. V in (Boscovich 1754a, No. 221).

preferred to adopt the second, being convinced that all the known properties of conics might be deduced from the principle which is common to all sections: the ratio between the distance of any point of the curve from the focus, and the distance of the same point from the directrix, is constant.

We also learn that Boscovich took great care that all proofs should be strictly geometrical, so that the young student, if well acquainted with Euclid's *Elements* and plane trigonometry, would not find difficulty in understanding them. Boscovich's concern for the students is clearly expressed in the long preface to the volume, which contains, as Taylor also remarked (1881, lxxvii), an earnest plea for the introduction of modern ideas into the school, which he had taught his own students "viva voce" with the best of results. According to Boscovich, the mind of the learner is often overwhelmed by so many details which are not reduced to a system, because the proofs are presented in such an uninspiring form that allows no stimulus for inventiveness, with the result that very few students turn out to be real geometers. So he added, "let us give him the principles, and not only fully explained facts, and let him be continually stimulated to find something for himself".⁴⁸ With this aim in mind, in his treatise on conics Boscovich was often led to dwell upon the speculations developed in the second part of the third volume.

The *Sectionum Conicarum Elementa* may be divided into two parts: the first, No. 1-545, treats the conics as defined in the plane; the second, No. 546-672, treats the sections of the cone, of the cylinder, and of other surfaces of rotation.

The first part contains two "Definitiones", (No. 1, 54), nine propositions, numbered by Roman numerals from I to IX (No. 34, 128, 140, 181, 206, 299, 351, 397, 495), each followed by several corollaries containing many theorems. To the 137 corollaries are intermixed 44 scholia, in which things worthy of note are recorded. Only one lemma (No. 204) is given, concerning the properties of the segments intercepted by two pairs of parallels on three concurrent straight lines (see section 4.3). Other definitions are either inserted into some propositions, as, for example, that of the "latus rectum" (see below), or scattered throughout the text. The second part contains three "Definitio" (No. 546, 590, 615), also followed by several corollaries and scholia.

The third volume of the *Elementa* is illustrated by 277 figures distributed over seven plates.

Boscovich distinguished the propositions according to whether they concerned the construction of conics, or the determination of their properties, labelling the former "problems", and the latter "theorems."

Of the nine propositions, the first three concern the construction of the conics:

- given directrix, focus, and determining ratio to find all points of the conic,
- finding the points of intersection of a straight line passing through the focus with the given conic,
- finding the intersection points of a general straight line with the given conic.

The third construction offered Boscovich the opportunity to introduce the eccentric circle.

The subsequent five propositions can be summarized as follows:

- Angular properties of the focal rays in the ellipse and in the hyperbola with respect to the tangent at a point, and of the focal ray in the parabola with respect to the tangent at a point and the perpendicular to the directrix at that point,

⁴⁸ (Boscovich 1754a, vii).

- The mid-points of any system of parallel chords of a conic all belong to the same straight line (a diameter), which for the ellipse and the parabola always passes through the centre, while for the parabola it is parallel to the axis,
- The chords theorem, as stated above,
- The constancy of the ratio between the square of any semi-ordinate and, in the case of ellipse and hyperbola, the rectangle constructed by the abscissae relative to the corresponding diameter, while in the case of parabola, the rectangle constructed by the abscissa relative to the corresponding diameter and the latus rectum,
- all straight lines through a fixed point and intersecting a given conic, are harmonically cut by this point, the points of intersection with the conic and the polar of the fixed point with respect to the conic.

Even if these results were well known, we will see that they were presented in a new way, that is as derived from the chords theorem, which Boscovich deduced from the properties of the eccentric circle.

The last proposition, for which we refer to section 4.5, is preparatory to the introduction of the osculating circle. This subject, quite unusual in a text on conic sections and that Boscovich aimed to treat in a purely geometrical way, was certainly included for its application to astronomy and geodesy.

In the second part, after defining the cone (“Definitio” III), No. 546, Boscovich showed that any conic section, as defined in the first part, is actually a section of a cone (No. 583), and vice-versa (No. 577); thus establishing the equivalence between the adopted definition of conic and the classical one. Then, in No. 615, he defined the cylinder (“Definitio” IV), and showed that any ellipse can be realized as a section of this surface (No. 609). Finally, (“Definitio” V), Boscovich introduced circular quadrics, and rotation solids, which he called “ellipsoidem”, or “spheroidem”, “parabolem”, or “conoidem parabolicam”, and “hyperboloidem”, or “conoidem hyperbolicam”, of which he showed several properties at the end of the book.

This last subject has certainly to do with Boscovich’s interest in the investigation of the shape of the earth and the study of the tides. In this regard, let us recall that, in 1740, Maclaurin had published *De causa physica fluxus et refluxus maris*, proposed by the Parisian Academy, which was also inserted into the third volume of L-J’s edition of the *Principia*.⁴⁹ In this memoir, Maclaurin solved the question of determining the force exerted by a spheroid on a point placed on its surface or inside it, by adopting purely geometric methods. In the next few years, Boscovich wrote the dissertation *De inaequalitate gravitatis* (1741), which was followed by others on the shape of the earth and *De maris aestu (On tide)* (1747), in which Boscovich quoted Maclaurin several times.

4.2 Three construction problems, and the definition of the eccentric circle

Boscovich opened his treatise with the definition of a conic section: “If for a given point P of a curve, a straight line PD is drawn perpendicular to a given straight line AB , and another straight line PF is issued to a given point F outside AB , so that PF and PD are constantly in the same ratio, then I call that line a conic section, ellipse, parabola, or hyperbola, according to whether the ratio is less than equality (i.e. < 1), or equal (i.e. $= 1$), or bigger than equality (i.e. > 1)”. Then he called AB *directrix*, F *focus*, and the given ratio *determining ratio*.⁵⁰

⁴⁹ See (Newton 1739-1742, vol. 3, 247-282).

⁵⁰ This is today commonly called eccentricity and denoted e , a symbol which for simplicity we also adopt in the sequel.

As in the article of 1746, after the definition, Boscovich stated and proved the same corollary 1 (No. 2), that we recalled at the beginning of the previous section (see fig. 5), after which he demonstrated some properties of the focal rays. In particular, in the corollary 4 (No. 8), he proved that for any straight line through the focus F that intersects the directrix at point Q and the conic at points P, p , the points p, F, P and Q are in harmonic proportion; that is, $Fp : FP = pQ : PQ$ (see fig. 7c).

In the next scholium II, Boscovich stressed the importance of the harmonic division in the study of conic sections, and recalled some facts to this regard. In No. 31, he proved, but without giving it the dignity of a proposition or corollary, the following important result (fig. 8a): *Let a circle be given and EH a chord of it perpendicular to the diameter AC , let the tangents to the circle at E and H intersect at point D , then, for any straight line through D cutting the circle in I and M , and the chord at L , the points M, L, I , and D , are in harmonic proportion.*

With proposition VIII, Boscovich will extend this result to conics.

Proposition I concerns the construction of points of the conic, having been assigned its directrix, focus and determining ratio e . To this end, he considered the orthogonal line HF to the directrix, called E the intersection point between these two lines, and on the directrix he took the point K so that $EK = FE$ (see fig. 8b). Next, he drew the straight line Tt through K and F , and on the parallel to the directrix through F he took FV and Fv such that their lengths equal eFE , so V, v are two points of the conic, and drew the straight lines iI and gG passing through E, V and E, v , respectively. Having denoted L and l , respectively, as the intersection points of these last lines with Tt , he drew the parallels to the directrix issued from L and l which meet Gg, Hh , and Ii at L, M, N, n, m, l , respectively. Afterwards, he considered a point S on the segment Ll , the parallel to the directrix passing through it, and the point P, p intersections of this last line with the circle having centre at F and radius $RQ = Ro$, where Q, o are the intersection points of this line with Gg, Ii . Since $FV : FE = RQ : RE = e$, these points are on the conic.

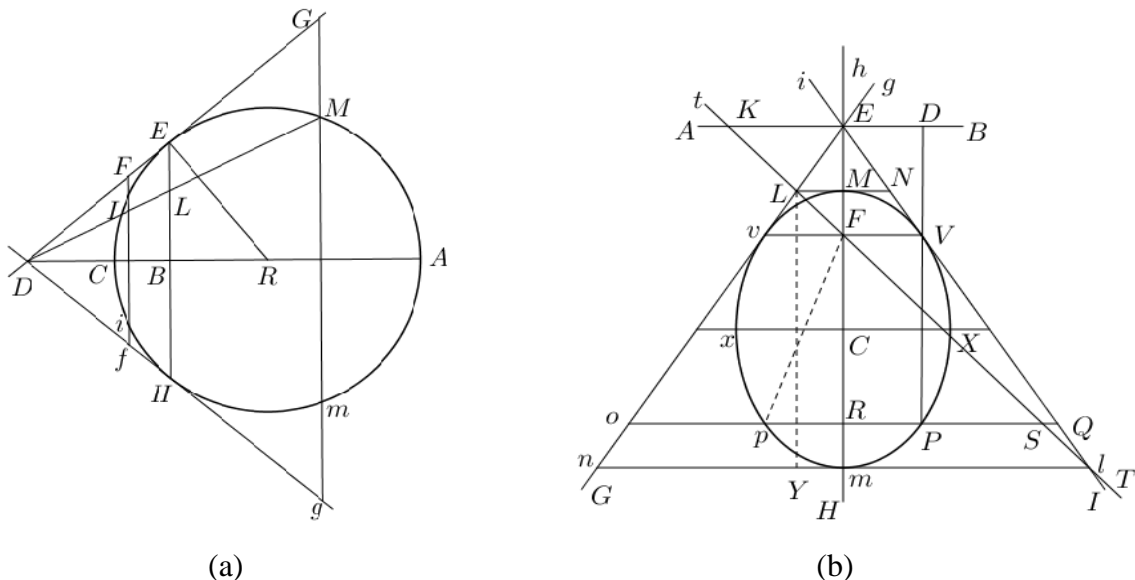

Figure 8 (a). Boscovich's figure 8 in (1754a). (b) Boscovich's figures 9 in (1754a). The perpendicular to the *directrix* AB through the focus F is the *axis*; M is the *vertex* (M is such that FM/ME equals the determining ratio, or *eccentricity*, e); the chord Vv is the *principal latus rectum*; in the ellipse and in the hyperbola, Mm is the *transverse axis*, the mid-point C of Mm is the *centre*, and Xx on the perpendicular to the axis passing through C is the *conjugate axis*; the segments intercepted on the perpendicular to the axis by the conic section, as Pp , are the *ordinates*.

In No. 50-53, on the basis of this construction, and arguing by absurdum, Boscovich showed that a conic section is “a never interrupted curve”, in fact, when point S moves continuously along LT , the point P also moves continuously on the conic. Let us observe that in the case of the parabola, or of the hyperbola, Boscovich foreshadows the transit of S through the point at infinity of the straight line LT , and of P through the point at infinity of the parabola, or of the points at infinity of the hyperbola, anticipating one the main themes that he would develop in the second part of his treatise.⁵¹

In the subsequent No. 54 (“Definitio II”), Boscovich gave the definitions of *principal latus rectum*,⁵² *transverse axis*, *centre*, *vertex*, *conjugate axis*, and *ordinates* (see fig. 8b). Then, with a series of twenty corollaries, he illustrated the main properties of these objects. For example, (No. 56, corollary 1) the transverse axis bisects all the ordinates, (No. 74, corollary 8) in the ellipse and in the hyperbola the ratio $PR^2/(MR \times Rm)$ is constant, while in the parabola PR^2/RM is constant (see fig. 9).

In No. 87, Boscovich showed that the ellipse and the hyperbola have two directrices (AB, ab), and two foci (F, f) (see fig. 9a,b). In No. 90, he pointed out that in the ellipse and in the hyperbola (fig. 9a,b), the distance between the foci, the transverse axis, and the distance between the two directrices, are in continuous proportion, as Ff to Mm , that is $Ff : Mm = Mm : Ee = FM : ME$.

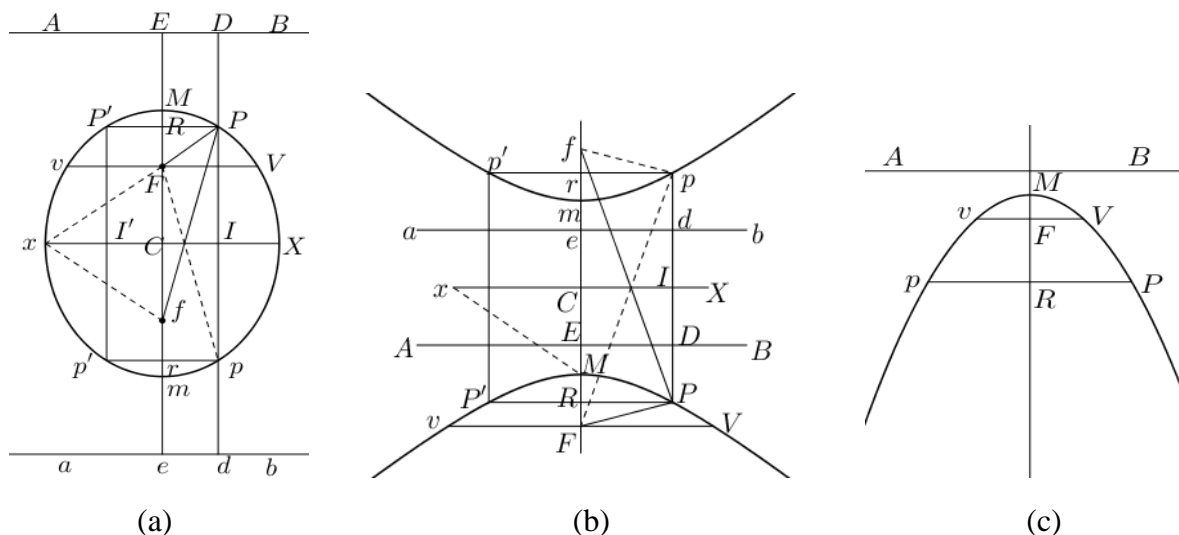

Figure 9 (a) Boscovich’s figure 19 in (1754a), for the ellipse is shown: the two directrices AB and ab , the two foci F and f , the two vertices M and m , transverse axis Mm , the conjugate axis xX , and the centre C . (b) Boscovich’s figure 20 in (1754a), for the hyperbola. (c) In the parabola, AB is the directrix, F is the focus, M the is vertex, the straight line through M orthogonal to AB is the axis.

Of particular interest is corollary 20 (No. 100), in which Boscovich, for the ellipse and the hyperbola, introduced what is today commonly known as *directrix circle* (see fig.10); that is, the circle centred at the focus f and radius equal to the transverse axis. The directrix circle has the peculiarity that, wherever the point P is on the conic, the straight line fP intersects the circle in a point D such that $FP = PD$.

Afterwards (No.102), Boschovich underlined an elegant analogy between this circle with the directrix of the parabola: when the second focus f goes infinitely far from the focus F , the conic

⁵¹ For details see (Del Centina, Fiocca 2018).

⁵² Boscovich postponed the definition of latus rectum pertaining to any diameter after proposition VII.

becomes a parabola, and the directrix circle becomes the directrix of the parabola.⁵³ With these considerations Boscovich again entered into questions pertaining to the principle of continuity. In fact, the adopted definition of conic section gave Boscovich the opportunity “to move”, or “to deform”, one conic into another, even degenerate, by constructing certain (continuous) plane systems of conics (No. 107-110). In particular, Boscovich stressed (No. 110) the usefulness of considering these continuous transformations because “they may disclose the true geometrical inner nature of conics”. Most likely, in dealing with the transformation of the conic sections, Boscovich was led to tackle the problem of the transformation of geometric loci, which resulted in the aforementioned dissertation that constitutes the second part of his treatise.⁵⁴

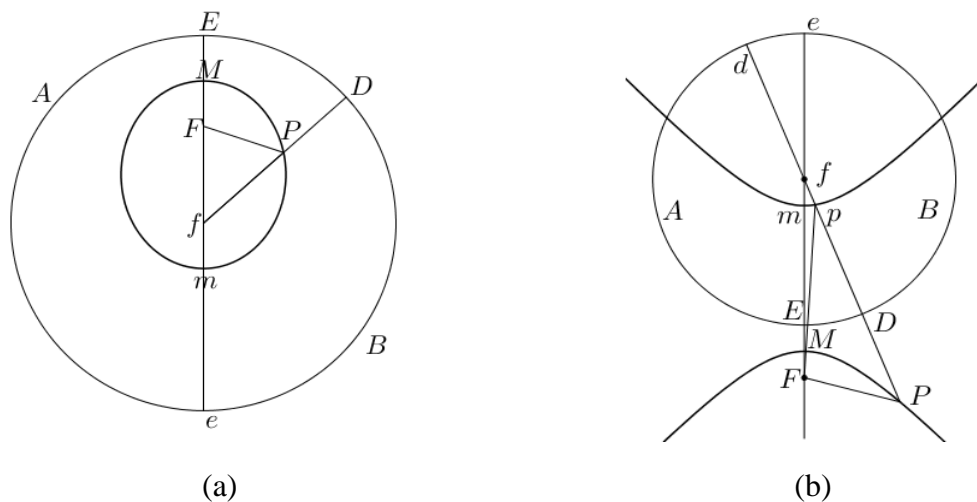
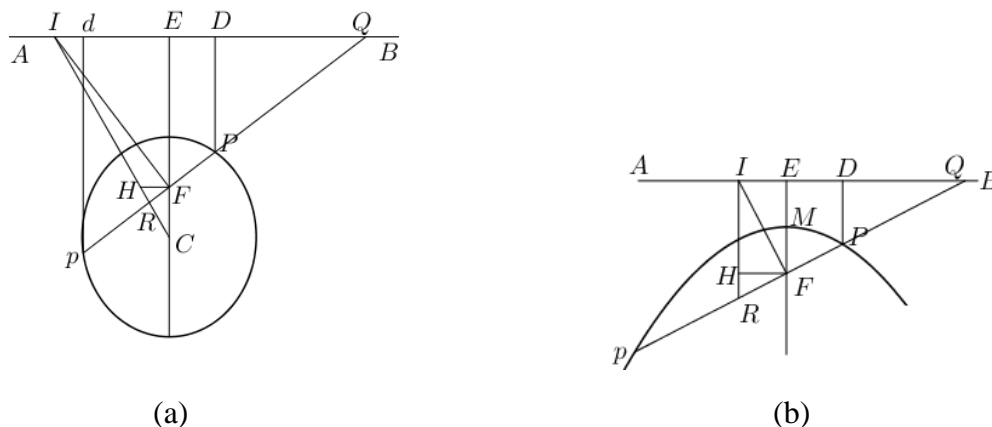

Figure 10 Boscovich’s figures 23 and 24 in (1754a), for the directrix circle ADB . The points of a central conic have equal distances from the focus F and the directrix circle.

With the second and third propositions (No. 128 and 140), Boscovich once more tackled the question of the construction of points of the conic section, having assigned its directrix, focus and determining ratio, the problem being to determine the intersection points of a given straight line with the conic. First, he considered a straight line passing through the focus (proposition II), and then a straight line not passing through the focus (proposition III). For the sake of space, we omit the first, but before presenting the second, which gave Boscovich the opportunity to introduce the eccentric circle, we briefly comment on the result of corollary 2 of proposition II, No. 134, that he often used later on (see fig. 11).



⁵³ A circumstance already remarked by Briggs, see (Del Centina, Fiocca 2018).

⁵⁴ See (Del Centina, Fiocca 2018) for more information.

Figure 11 (a) Boscovich's figure 37 in (1754a), illustrating the results of No. 134 for the case of the ellipse. (b) Boscovich's figure 38 in (1754a), illustrating the results of No. 134 in the parabola. In both figures, by corollary 4 (No. 8), the straight line FP is harmonically divided by the points p, F, P, Q .

Let Pp be a chord passing through the focus, which prolonged (if necessary) intersects at Q the directrix AB of the given conic section. If R is the midpoint of the chord, and I is the point at which the perpendicular to the chord, issuing from F , intersects the directrix, then 1) $RF:RP = RP:RQ = FP:PQ$ and 2) the straight line IR passes through the centre in the ellipse and the hyperbola, and is perpendicular to the directrix, that is parallel to the axis, in the parabola.

To solve the problem of the third proposition, that is, to find the intersection of the straight line not passing through the focus with the conic, he proceeded as follows. Let a conic section be defined by directrix AH , focus F , and determining ratio e , and let HK be the given straight line intersecting the directrix AB at point H (fig. 12).

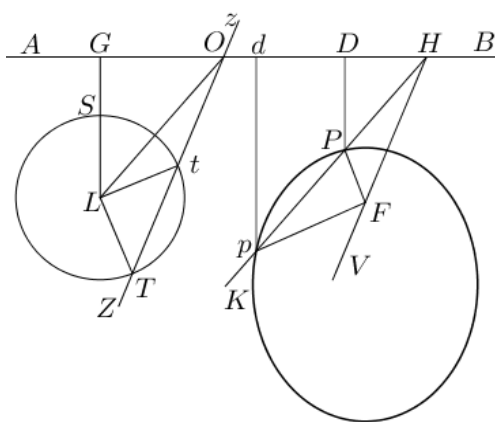

Figure 12 Boscovich's figure 41 in (1754a), for the proof of proposition III.

He considered a point L not on the directrix, and a circle with its centre at the point L and radius equal to the distance of L to the directrix, times the eccentricity e (we will call it "eccentric circle" with respect to L), then he drew the straight line through L parallel to the given straight line, which will intersect AB in O . Next, he issued from O the line parallel to the line HF , which meets the eccentric circle in points t, T , and drew from F the focal radii parallel to tL, TL . These two straight lines through F will meet the given line HK in P, p . Then, if LG, PD are perpendicular to the directrix, it results that $PF:PD = LT:LG = e$, which means point P belongs to the conic. The same holds true for point p .

We may observe that under this construction, secants and tangents to the eccentric circle, are transformed into secants and tangents to the conic. This provides a powerful but quite elementary method by means of which the properties of a conic may be inferred from those of a circle while avoiding the cone; that is, "without projection and section".

Since Boscovich did not explain how he reached the concept of the eccentric circle, we can only conjecture, but it may have been by pondering the proof of the chords theorem as explained in section 3 (fig. 6).

In the subsequent scholium, Boscovich pointed out, "It is remarkable just how productive this construction is, and how suitable it is for stimulating the student",⁵⁵ and stressed that it can be simplified by assuming the centre of the eccentric circle in certain special positions, as on the conic,

⁵⁵ "Mirum sane quam foecunda est haec constructio, quam Tyroni exercendo apta", [Boscovich 1754a, No. 145].

at the focus, at the centre of conic – in which case the eccentric circle becomes the auxiliary circle – and on the given straight line, whose intersection points with the conic section are sought. This last observation seems to give force to the aforementioned conjecture on how Boscovich developed the idea of the eccentric circle, and, in fact, as we will see later (proposition VI), it is connected with the new proof of the chords theorem that Boscovich presented in the treatise. The second case is also important in relation to certain plane transformations connected with Boscovich’s construction, which we shall briefly mention at the end of section 5.

In the subsequent corollary 1 (No. 149-150), Boscovich showed that all points of a conic section can be found from the above construction by moving the straight line HK parallel to itself, when point H traversing the directrix AB . For, if HK keeps its direction, the straight line LO and the point O remains fixed, while OZ rotates around O .

So, as Boscovich remarked, in the case of the ellipse (No. 153), among the straight lines parallel to a given direction, two touch the ellipse and of the remaining, those which lie between the two tangents, cut the ellipse at two points, while the others do not meet it at all. In the case of the parabola (No. 154), he observed that among the straight lines parallel to a given direction, but not orthogonal to the directrix, only one is tangent to the parabola, while the others intersect the curve at two points, or do not cut it at all. If the straight lines are perpendicular to the directrix, they intersect the parabola at only one point, because “the other receded to an infinite distance, until it disappeared”.⁵⁶ In this way, Boscovich introduced the “point at infinity” of the parabola.⁵⁷ For the hyperbola (No. 155-157), Boscovich considered three cases according to whether the (constant) angle AHK , is less, equal, or greater than the angle LNn , where N and n are the intersections of the eccentric circle with the directrix (see fig. 13). In the first case, the parallel straight lines intersect one branch, or its opposite, in two points or they do not intersect the hyperbola at all, and in the third, they intersect each branch in only one point. The second case led him to introduce the *asymptotes* (see fig. 13). In fact, in this case, only one of the parallels fails to meet the hyperbola, though it approaches each branch by less than any given arbitrarily small quantity; all the others meet the curve in only one point, the other point receding to infinity. The directions of LN and Ln correspond to the directions of the asymptotes.

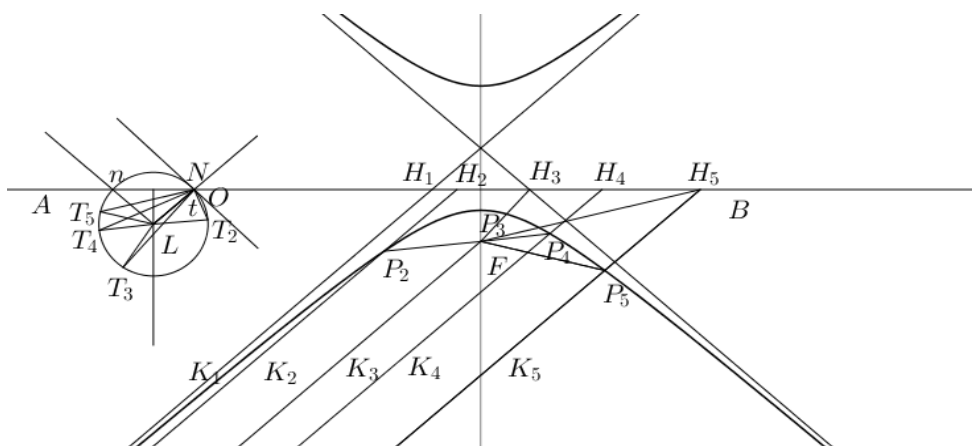

Figure 13 A variation of Boscovich’s figure 50 in (1754a), for the definition of the asymptotes.

This shows how easy it is to introduce the asymptotes by means of the eccentric circle.

⁵⁶ “altera intersectione ita in infinitum abeunte, ut nusquam jam sit”, (Boscovich 1754a, No. 154).

⁵⁷ The first to introduce this concept was Kepler in 1604, see (Field 1986), also the very recent (Del Centina 2016) and the references therein.

With corollary 2 (No. 158), Boscovich showed that a straight line cannot intersect a conic section in more than two points, and it cannot touch it in more than one.

After having stressed the “admirable nature of asymptotes” (No. 160), Boscovich gave corollaries the 3, 4, 5 and 6 (No. 164-171). The first three regarding the properties of the asymptotes: they are two; they are perpendicular to the straight lines FH , Fh , respectively (see fig. 14a) passing through one of the two foci and the intersection points of each asymptotes with the directrix; the segments FH , Fh are equal the conjugate semi-axis CX , etc. The latter regarding the *conjugate hyperbola* (that is, the hyperbola which has as transverse and conjugate axis, the conjugate and transverse axis, respectively, of the given one): two conjugate hyperbolas have common asymptotes, share the same centre, and have equal focal distances (see fig. 14a).

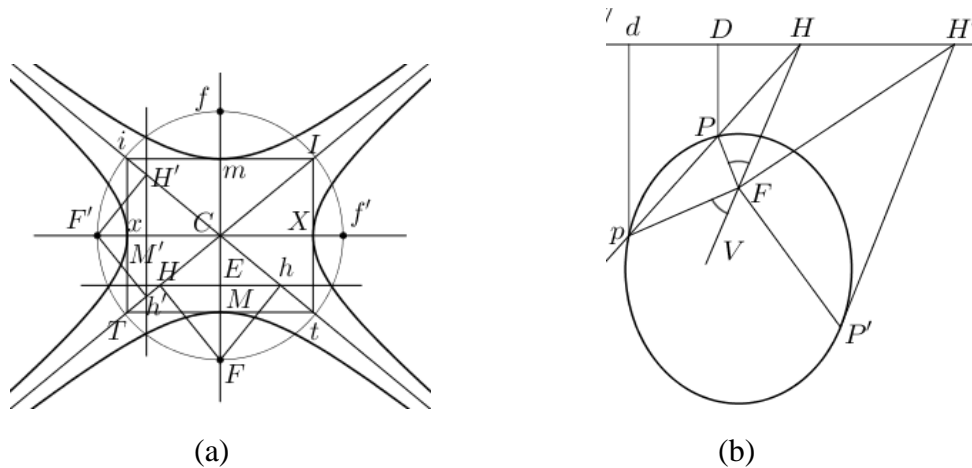

Figure 14 (a) Enhanced version of Boscovich’s figure 52, illustrating the properties of the hyperbola and its conjugate; here are drawn the foci of both hyperbolas, the circle centred at C through them, and two of the four directrices, Hh , $H'h'$. (b) Illustrates corollary 7: the angles $\angle PFH$ and $\angle pFV$ are equal, and $\angle P'FH'$ is a right angle.

In corollary 7 (No. 173), by using the eccentric circle, Boscovich showed that if a straight line Pp intersects the conic section in two points P , p , the focal rays PF and pF form equal angles with the straight lines HF . Moreover, if the straight line is tangent to the conic section, the focal ray to the contact point, and the straight line from F to the intersection point of the tangent with the directrix, form a right angle (see fig. 14b).

4.3 Four propositions proved by using the eccentric circle.

To show the usefulness of the eccentric circle, Boscovich went on to prove four fundamental propositions by means of it, the first of which is (fig. 15):

Proposition IV (No. 181): *In the ellipse and in the hyperbola, the straight lines joining a point of the conic section to the foci, are equally inclined with respect to the tangent to the conic section at that point. In the parabola, the straight line joining one point to the focus and the parallel to the axis issuing from the same point, make equal angle with the tangent at that point.*

To prove this proposition, Boscovich used corollary 7 mentioned above, so, though indirectly, he once more used the eccentric circle.

The only lemma present in the treatise appears in No. 204. Since the second part of it (that is the converse of the first claim) was to play a fundamental role in the proofs of propositions V and VIII, it is worthwhile enunciating it.

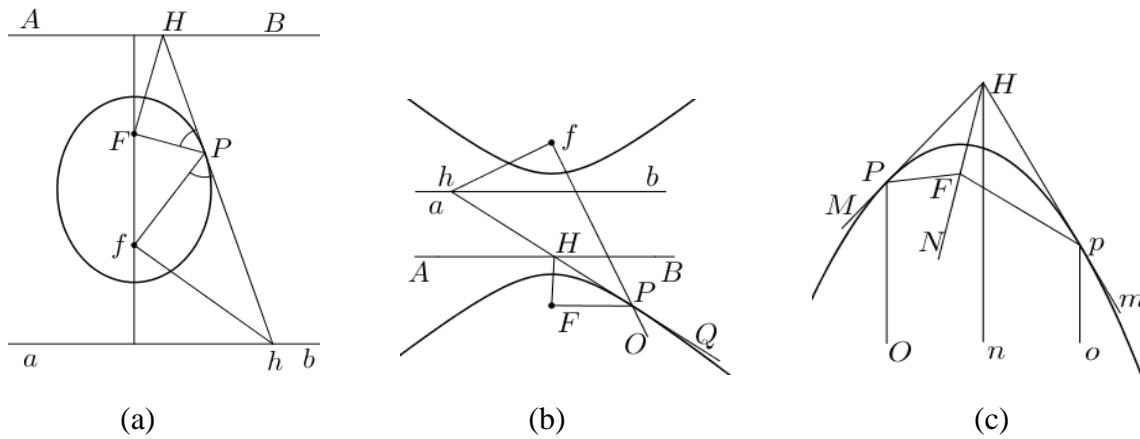

Figure 15 (a) Boscovich's figure 55 in (1754a) illustrating proposition IV in the case of the ellipse, AB and ab are the two directrices. (b) Boscovich's figure 56 for the hyperbola, AB and ab are the two directrices (c) is Boscovich's figure 57, illustrating the proposition IV in the case of the parabola.

Lemma (fig. 16): *Let three straight lines Pp , Qq and Tt meet at the same point F , and from H , h on Pp , let two parallels be drawn which intersect Tt at A , a , respectively, and other two parallels HR , hr which intersect the other line Qq at R , r , respectively, then $HA : HR = ha : hr$ is always true. For every point H chosen on Pp , if HA and HR maintain their directions, the ratio is constant. The converse is also true: let HA , ha , two parallel segments, and HR , hr two other parallel segments be given so that $HA : HR = ha : hr$, then if the straight lines Aa , Hh intersect each other in F (or are parallel to each other), then the straight line Rr passes through F (or it is parallel to the previous two). Moreover, if the ratio HR/HA and the directions of HR , HA remain the same, then, when the points H and A slide on Hh and Aa , respectively, the points R , r slide on Rr .*

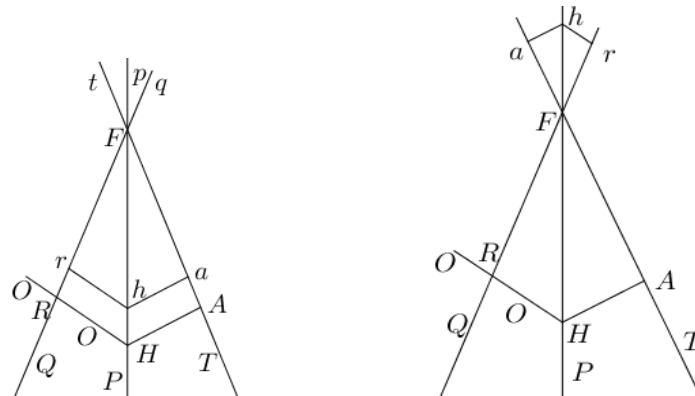

Figure 16 Boscovich's figures 69 and 70 in (1754a), for the proof of the lemma in No. 204.

Next, Boscovich introduced the "diameters" of a conic section (No. 206-209).

Proposition V. *A diameter, which for the ellipse and the hyperbola always passes through the centre, and for the parabola is always perpendicular to the directrix, that is parallel to the axis, bisects all the parallel chords of the conic, having a given inclination, which are called ordinates.*

In No. 56, 83, Boscovich had already proved the proposition in the case in which the chords are parallel, or orthogonal, to the directrix. To prove the proposition when the chords are generically positioned, he first showed that all midpoints of a continuous family of parallel chords of a conic

section are collinear, then that the straight line on which the midpoints lie, in the ellipse and the hyperbola, passes through the centre of the conic, and is parallel to the axis in the parabola. Boscovich called this straight line a *diameter*. The chords, which are bisected by a diameter are said to be the *ordinates* (pertaining, or relative, to that diameter). To reach his goal Boscovich again used the eccentric circle. We supply the proof only for the case of the ellipse, slight modifications only are required for the other cases.

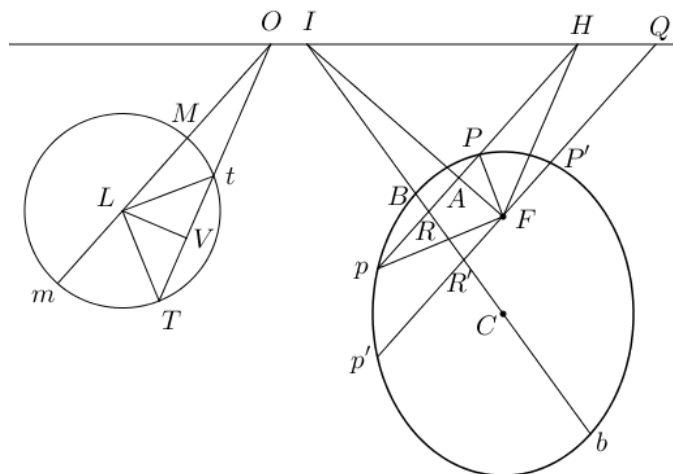

Figure 17 Boscovich's figure 71 in (1754a), illustrating the proof of proposition V for the case of the ellipse.

For the first step, Boscovich argued as follows. Let the chord Pp (not passing through the focus) be given, and let R be its midpoint (fig. 17). From the focus F , let the chord $P'p'$ be drawn parallel to Pp , which produced (if necessary), cuts the directrix at Q . Let FI be the perpendicular from F to the straight line FQ , which meets the directrix at I . Let us say R' is the midpoint of the chord $P'p'$. By corollary 2 of proposition II (No. 134), the straight line IR' passes through the centre of the conic section, in the ellipse and in the hyperbola, and it is orthogonal to the directrix, that is, parallel to the axis, in the parabola. By making use of the eccentric circle, and by the similarity of the triangles PHF , OLT and pHF , OLt , it follows that $HP : HF = OL : OT$ and $HF : Hp = Ot : OL$, and, therefore, $HP : Hp = Ot : OL$. By applying the *componendo* $(HP + Hp) : HP = (Ot + OL) : Ot$, which in turn implies $HR : HP = OV : Ot$. On the other hand, $HP : HF = OL : OT$ and $HF : HA = OL : OV$, therefore, $HR : HA = OL^2 : (Ot \times OL)$. But the latter ratio is constant for any position of the chord Pp , if its inclination is maintained, because, in this case, O, M, L, m , remain fixed. Then, by the lemma of No. 204, all the points R are on the same straight line. As the ratio $HR : HA$ does not change when the points H, A slides along the straight lines HI and IF , respectively, then also the point R slides along the straight line which passes through I ; that is, all the points R are collinear, and all the chords not passing through the focus, having the given direction, are bisected by the same diameter.

To prove that the diameter coincides with the straight line IR' , Boscovich proceeded in two ways.

In the first, he applied the principle of continuity by observing that, though the construction above does not work for the chord which passes through the focus, it holds true for all the chords PRp as close as one wants to that, so that the result is true also for the chord through the focus. In the second, "faithful" (*accuratissime*) proof, he made use of the result in No. 134, connected with the harmonic division, and other previous results. For sake of brevity we do not reproduce this proof here.

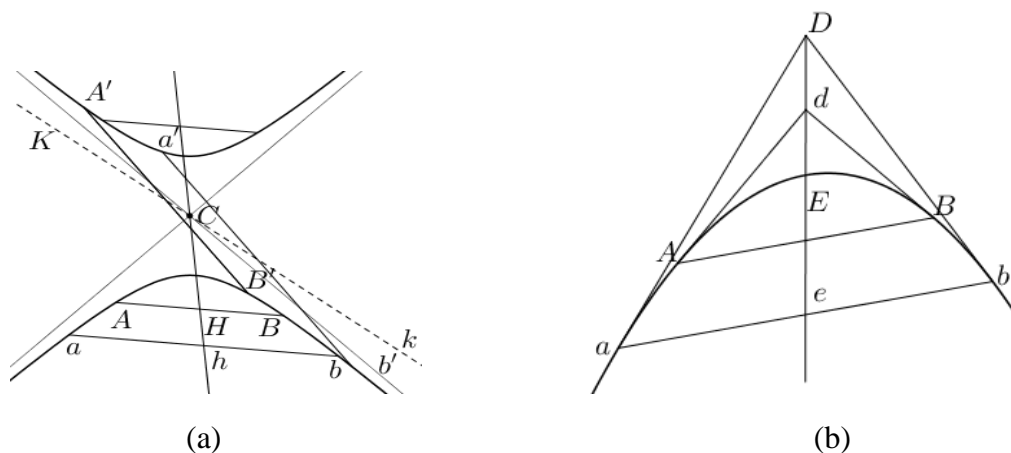

Figure 18. (a) The straight line Hh is a primary diameter, while the straight line Kk is a secondary diameter of the hyperbola. (b) Boscovich's figure 76 in (1754a), for corollary 4 (No. 216); DE is the diameter along which the tangents, at the extremities of the parallel chords AB and ab , intersect.

Proposition V is followed by a series of 23 corollaries, and a number of scholia, regarding properties of the diameters of the three kinds of conic sections. We mention only a few. In corollary 1, Boscovich showed that in the ellipse and in the hyperbola all straight lines through the centre are diameters, and in the parabola all straight lines parallel to the axis are diameters. Then, in corollary 2, he separated into *primary*, and *secondary*, the diameters of the hyperbola according to whether they are, or are not, included in the sectors determined by the asymptotes which contain the two branches (fig. 18a). With corollary 4, he proved that for any system of parallel chords, the two tangents to the conic section at the extremities of each of them always intersect along the same diameter (see fig. 18b).

In No. 299-300, Boscovich introduced the chords theorem, enunciated in the following (not explicit) form:

Proposition VI. *If two straight lines, through any given point, intersect a given conic section in two points, then the rectangles contained under the intercepts, that is the segments between the common point and the intersections with the conic, are in a ratio which only depends on the determining ratio of the conic section, and the directions of the two straight lines. If a straight line is tangent to the conic, then the square of the tangent segment has to be substituted to the rectangle. Moreover, if two other straight lines meeting in any other point, but with the same directions of the previous, are taken, then the ratio of the rectangles, or of the squares, does not change.*

Let the conic be defined by its directrix AB , the focus F , and determining ratio e (fig. 19), and let the chord Pp and a point L on it, or on its prolongation, be given.⁵⁸ Boscovich produced the chord until it meets the directrix in H , then he drew the eccentric circle centred at L , and the straight line FH cutting it in the points T and t . By the construction of No. 140, $FP \parallel LT$ and $Fp \parallel Lt$, then, by similarity of triangles, Boscovich obtained that $LP : TF = LH : TH$, and $Lp : tF = LH : tH$. Therefore

$$\frac{LP \times Lp}{TF \times tF} = \frac{LP \times Lp}{DF \times Fd} = \frac{LH^2}{TH \times tH} = \frac{LH^2}{MH \times Hm} = \frac{LH^2}{LH^2 - LM^2}.$$

⁵⁸ Boscovich, without saying it, is supposing L to be the point of intersection of the two chords mentioned in the statement.

Then, he observed that by corollary 1 to the first definition (see sections 3 and 4.2) the last ratio only depends on the direction of the chord Pp and the determining ratio (the eccentricity), and the same holds for the rectangle $Lp \times LP$.

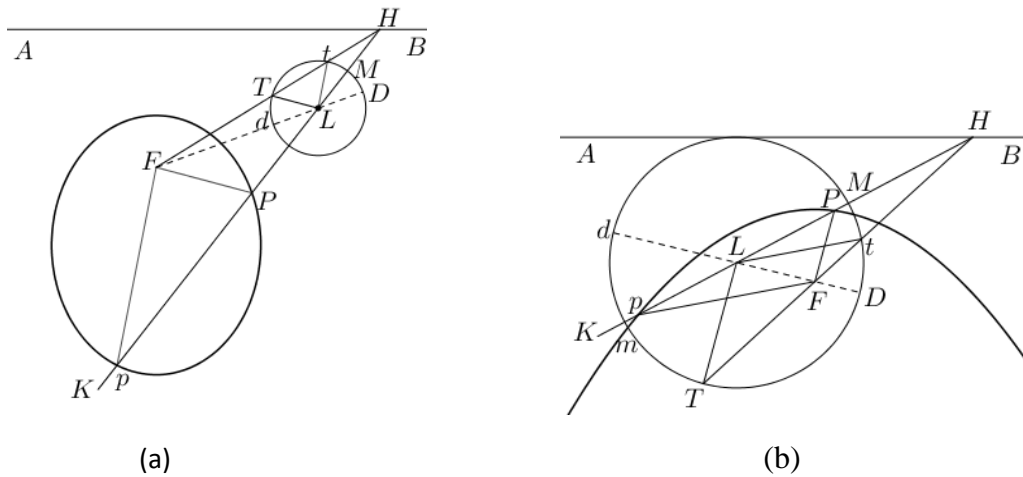

Figure 19. (a) Boscovich's figure 90 in (1754a) for the proof of proposition VI. This illustrates the case in which the point L , intersection of a pair of chords, is outside the conic section. (b) Boscovich's figure 91 in (1754a) for the proof of proposition VI, when L is inside the conic section and the conic is a parabola.

Now, if we consider another chord $P'p'$, of different direction, but that, when produced, passes through L , we still have that the rectangle $Lp' \times LP'$ only depends on the inclination of the chord and the determining ratio. Therefore, the ratio between the two rectangles formed by the intercepts only depends on the inclinations of the two chords, and the determining ratio.

So, affirmed Boscovich, if one takes any other point and two straight lines through it, each intersecting the conic section in two points and parallels to the previous, the ratio between the rectangles formed with the intercepts is the same as before.

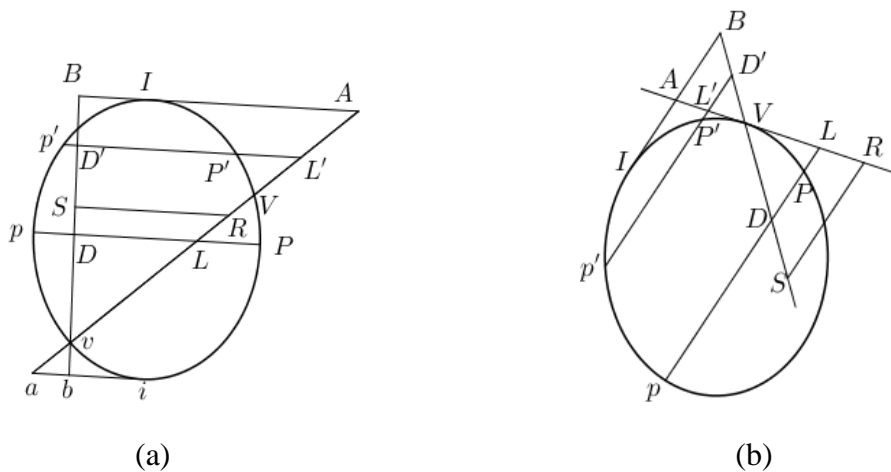

Figure 20. (a) Boscovich's figure 115 in (1754a) for the proof of corollary 5 in No. 317. (b) Boscovich's figure 117 in (1754a) for the proof of corollary 7 in No. 321.

To this proposition Boscovich attached 12 corollaries and a number of scholia. Here we mention corollary 5 (No. 317): if two chords or tangent lines, parallels among them, are cut by a transversal, then the rectangles under the intercepts, or the squares of the tangents, are in the same ratio as the rectangles under the segments of the transversal, that is, $PLp: P'L'p' = VLv: VL'v$, and $IA^2: ia^2 = VA v: Vav$ (fig. 20a). Corollary 7 (No. 321) is the special case in which the transversal is tangent to

the conic, in this case the rectangles on the transversal have to be substituted by the squares of the tangent segments (see fig. 20b). Boscovich used this corollary in the proof of proposition VIII.

In No. 351, Boscovich enunciated the seventh proposition, which, according to him (No. 350), leads to many results of frequent use in the study of conic sections. By this proposition he also defined the latus rectum, or parameter, pertaining to a diameter.

Proposition VII. *In the ellipse and in the hyperbola, the square of the semi-ordinate of any diameter is in a constant ratio to the rectangle contained by its abscissae from the two vertices, which is equal to the ratio between the squares of the conjugate diameter and of the diameter itself or their halves. If, as in the case of the axis, the third proportional to the diameter and the conjugate diameter [that is, looking at fig.21a,b, $Aa^2 : Vv$] is called parameter, or latus rectum, and the diameter is called latus transversus, then [the ratio between the square of the semi-ordinate and the rectangle contained by the abscissae] is equal to the ratio between the latus rectum or parameter and the latus transversus or diameter. In the parabola, [the square of the semi-ordinate] equals the rectangle given by the abscissa from the vertex of the diameter and a constant segment, that I call latus rectum or parameter, equal to the ordinate through the focus, which, in turn, is four times the distance between the vertex of the diameter from the focus, or from the directrix [that is, looking at fig. 21c, $P'L'=4VF$].*

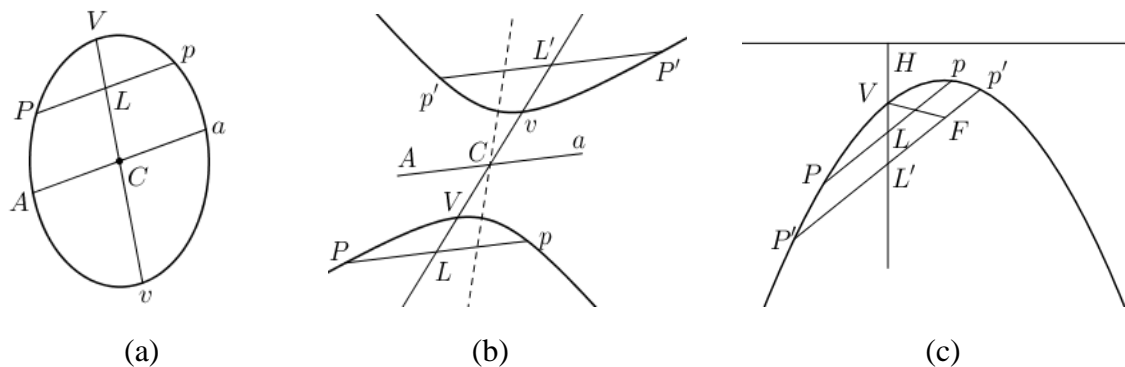

Figure 21. Boscovich's figure 134, 135, and 136 in (1754a).

In particular, in the ellipse and the hyperbola (fig. 21a,b), we have

$$\frac{PL^2}{VL \times Lv} = \frac{AC^2}{VC^2}$$

while for the parabola we have (fig. 21c)

$$\frac{PL^2}{VL \times P'L'} = 1.$$

To prove all the claims, Boscovich used propositions V and VI. For sake of space we do not reproduce here his proofs.

After having proved a number of corollaries illustrating some properties of the ellipse, Boscovich continued to show the power of the chords theorem by proving a proposition of "projective character".

4.4 The last two propositions

The first regards the harmonic property of secants, well known to La Hire who made it the key tool to develop the whole theory of conic sections (La Hire 1685).

This is proposition VIII (No. 397): *If from the intersection point Q of the tangent PQ with the diameter QR a straight line is drawn so that it intersects the conic section at T, t and the ordinate Pp at K , then QK is the harmonic mean between QT and Qt . In the case of the hyperbola, if KT and Kt are on opposite branches, then QK is the harmonic mean between KT and Kt .*⁵⁹

Although Boscovich never considered the correspondence “pole, polar” with respect to a conic, nor even used these terms, to understand the meaning of this proposition better it is worth re-wording it as follows: all straight lines through a point Q and intersecting a conic section, are cut harmonically by Q , their intersections with the conic section itself, and with the polar of Q with respect to the conic.

To prove this, Boscovich proceeded as follows (see fig. 22). He drew the straight line Qp and issued from T, t the parallels to Pp intersecting QP, QR, Qp at H, h, I, i, L, l , respectively, and the conic section at S, s . Since the ordinates TS and ts are bisected at I, i , by the Lemma (No. 204), HS, hs are equal to TL, tl , respectively, so the rectangles THS, ths are respectively equal to the rectangles HTL, htl . Since $HT : ht = TL : tl = QT : Qt$, is $QT^2 : Qt^2 = HT \times TL : ht \times tl = TH \times HS : th \times hs$, and therefore, by No. 321, the last ratio is equal to $PH^2 : Ph^2 = KT^2 : Kt^2$, and so $QT : Qt = KT : Kt$.

It is clear from the proof that also this proposition depends on the chords theorem, and this shows that definition 1 and the concept of eccentric circle underpin the whole theory of conic sections. It is worth to notice that La Hire used the projection method in order to extend the claim from the circle to conics.⁶⁰

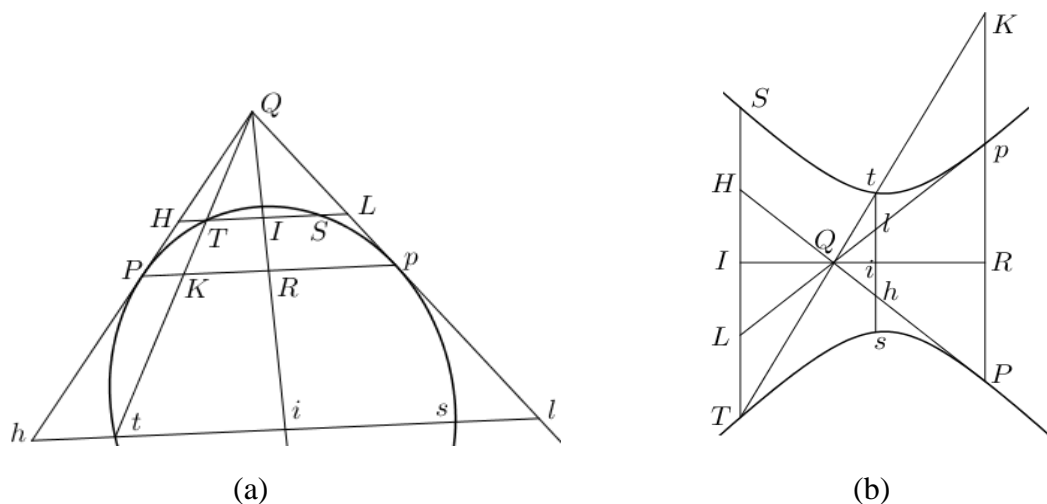

Figure 22. (a) Boscovich’s figure 150 in (1754a), proposition VIII, in the case of the ellipse. (b) Boscovich’s figure 152 in (1754a), proposition VIII, in the case of the hyperbola when T and t are not on the same branch.

Scholium V to proposition VIII contains important results. First, in No. 443, Boscovich observed that if two parallel chords of a conic are known, also the corresponding diameter is known, and if

⁵⁹ Given three magnitudes $a < b < c$, b is said the harmonic mean between a and c if the proportion $a:c = (b-a):(c-b)$ holds true. Boscovich considered $QT = a$, $QK = b$, $Qt = c$. In the case of the hyperbola, when T and t are not on the same branch, (fig. 22b) Boscovich considered $Kt = a$, $QK = b$, $KT = c$.

⁶⁰ See (La Hire 1685, books I, II).

two pairs of parallel chords, in different directions, are known, then either the conic is a parabola (if the two diameters are parallel to each other), or also the centre of the conic is known. Then, in No. 444, he remarked that, on the basis of previous results (No. 436, 438, 441), in all cases the conic is determined.

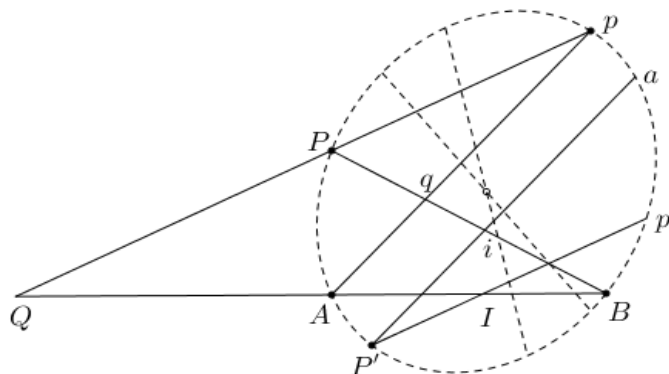

Figure 23. Enhanced version of Boscovich figure 169 in (1754a), which illustrates the procedure for the determination of the conic passing through five given points. The dashed line, representing the conic section through the five given points, is not present in the original figure.

In No. 453, Boscovich showed how to find the conic passing through five (distinct) given points. Let points A, P, p, B and P' be given (fig. 23), join A with B and P with p , if the chords AB, Pp are parallel, they determine a diameter, otherwise they meet at point Q . Issuing from P' the parallel to Pp , then the other intersection of this straight line with the sought-for conic, say p' , is determined, in accordance with the chords theorem, by the relations

$$\frac{QP \times Qp}{QA \times QB} = \frac{QP \times Qp}{AI \times IB} = \frac{P'I \times Ip'}{AI \times IB}.$$

At this point, having a pair of parallel chords, Pp and $P'p'$, a diameter is also known. Now, starting with the chords PB and Ap , and the straight line through P' parallel to Ap having been drawn, with the same procedure as before, we find the second intersection a of it with the sought conic. We have a second pair of parallel chords, and then another diameter. When two diameters are known, by means of the above results, the conic is also known.

The last proposition concerns the osculating circle, the subject from which he started in 1740. In No. 494, he wrote:

We continue by showing another property of the conic sections, that gave them the names of ellipse, parabola, and hyperbola, and which can be deduced from proposition six, being a particular case of the corollary proved in No. 319, but we will derive it from proposition seven, thus opening the route to the determination of the osculating circle to a conic by means of finite geometry.

Then Boscovich observed that as between an arc of circle and the tangent, no other straight line can be drawn, though infinitely many arcs of circles can be traced, so between the arc of a conic section and the arc of the osculating circle, no other arcs of circle can be drawn.

Proposition IX (No. 495): *from the vertex V of any diameter in the ellipse fig. 186 [here fig. 24a] and in the parabola fig. 187 [here fig. 24b], and from the vertex V of any primary diameter in the hyperbola fig. 188 [here fig. 24c], let a tangent be drawn to the conic, and let us take on it a point A so that VA is equal to the latus rectum. Then let A be joined with the other vertex v , in the case of the ellipse and hyperbola, while in the case of the parabola let the parallel to the axis be drawn*

from A. The straight line Av, or the parallel to the axis from A, intersects the ordinate PRp at L. Then the square over the semi-ordinate RP equals the rectangle constructed by the abscissa VR and the intercept RL between the diameter and the straight line Av, an intercept which is the fourth proportional after the latus transversus, the latus rectum and the abscissa relative to the other vertex, to which the latus rectum is not applied. In the parabola the square and the rectangle are equal to the rectangle constructed with the abscissa VR and the latus rectum; in the ellipse the square and the rectangle are less than the rectangle constructed with the abscissa VR and the latus rectum; in the branch of the hyperbola where the latus rectum is applied, the square and the rectangle exceed the rectangle constructed with the abscissa VR and the latus rectum, and the excess part is the rectangle constructed with the abscissa itself and the fourth proportional after the latus transversus, the latus rectum and the same abscissa.

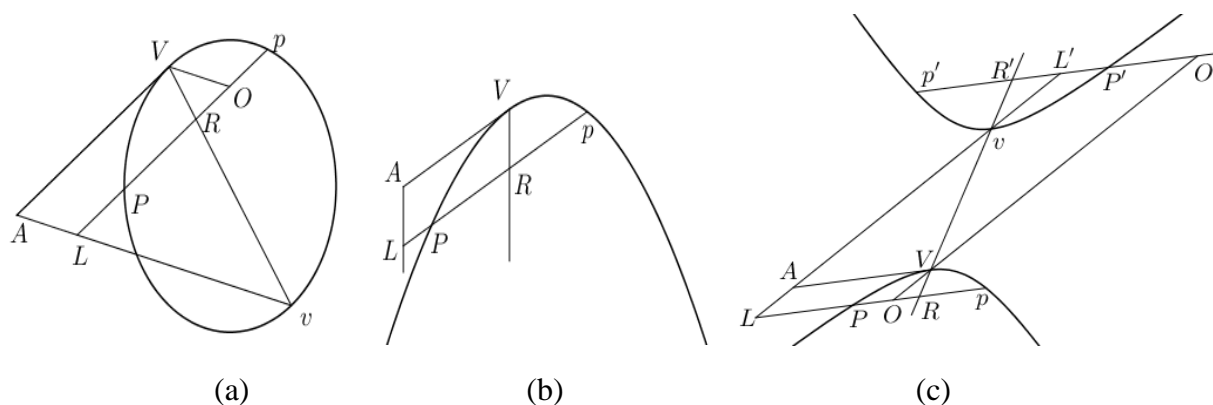

Figure 24. Boscovich's figures 186, 187, and 188 in (1754a), for the proof of the proposition IX.

In formulae: $RP^2 = VR \times RL$, where RL is such that $Vv : VA = Rv : RL$; the exceeding part and the missing part are each equal to $VR \times OR$.

To prove the proposition, Boscovich proceeded exactly as he had done in the dissertation *De circulis osculatoris* (1740). Then in the second corollary to the proposition (No. 503), he showed that a circle is the osculating circle of a conic at a point, if, and only if, it shares the same tangent with the conic and cuts on the diameter through that point a segment which is equal to the latus rectum relative to that diameter. The proof of this corollary is carried out in No. 505-508, and it is substantially the same as the one he developed in (1740).

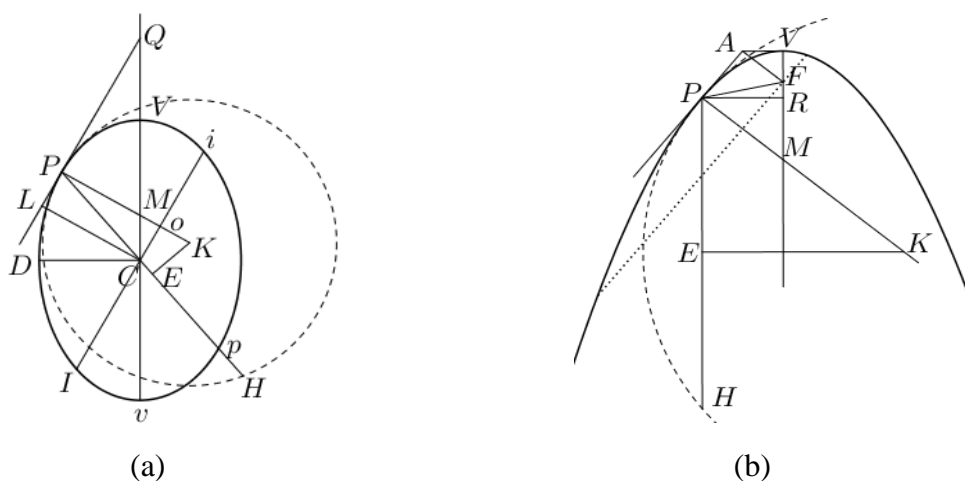

Figure 25. (a) Enhanced version of Boscovich's figure 192, with the addition of the osculating circle (dashed). We notice the similarity with fig. 1b. (b) Enhanced version of Boscovich's figure 194 in (1754a), with the addition of the latus rectum (dotted line), and (an arc) of the osculating circle (dashed).

In the subsequent corollaries, Boscovich demonstrated some properties of the osculating circle. For instance, he showed that: 1) the diameter of the osculating circle at a vertex of the transverse axis, in the ellipse and in the hyperbola, and of the axis in the parabola, equals the principal latus rectum, and it lies entirely inside the conic; 2) the osculating circle at a vertex of the conjugate axis of the ellipse lies entirely outside the ellipse. Of particular interest are the corollaries 7, and 8 (No. 520-22, 523-25). The first asserts that in the ellipse (fig. 25a), and in the hyperbola, the radius PK of the osculating circle is the third continuous proportional after the perpendicular CL from the centre of the conic section to the tangent at P , and the conjugate semi-diameter CI ; that is $CL : CI = CI : PK$.

In fact, let Pp be the diameter, PH on it equal to the latus rectum, E its middle point. Moreover let K and L be, respectively, the intersection of perpendicular to the diameter issued from E with the perpendicular to the tangent issued from P , and the intersection of the tangent with the perpendicular to it issued from C . Boscovich first considered the similar triangles PLC and PKE , to obtain the proportion $CL : CP = PE : PK$, then, since by proposition VII one has $CP : CI = CI : PE$, the claim easily follows. In corollary 8 Boscovich showed that in any conic sections the radius PK of the osculating circle satisfies the proportion $PK : L/2 = PM^3 : (L/2)^3$, where L is the principal latus rectum and PM is the segment intercepted by the transverse axis on the perpendicular to the tangent (see fig. 25a, b). For the ellipse and the hyperbola, the proof essentially follows from corollary 7, while for the parabola, it follows from proposition VII and the results in No. 198, 200.

5 THE RECEPTION OF BOSCOVICH'S TREATISE

The three volumes of Boscovich's *Elementa* met wide approval and the whole work was reissued in Venice in 1757.⁶¹ However, this was a short-term success. In the following years certain events occurred that interrupted the editorial success of the work in Italy: the abolition of the Jesuit Order in 1773, and the gradual replacement of Latin by Italian as the language in mathematical teaching.⁶² The contents of the first two volumes of Boscovich's work were included in several didactic texts, as, for example, the *Istituzioni analitiche* by Maria Gaetana Agnesi (1748), and the *Lezioni elementari di matematiche*, the Italian translation of *Leçons élémentaires de mathématiques* by Joseph-François Marie, which ran several editions.⁶³ As regards Boscovich's treatise on conic sections, its entirely geometrical treatment may have prevented its lasting success, considering that in the second half of the eighteenth century analytical methods in geometry were widely used at the expense of synthetic methods. Moreover, a geometrical compendium on conic sections was available in Italian, the *Compendio delle sezioni coniche d'Apollonio* by Guido Grandi (1722), which enjoyed good fortune.⁶⁴ What is more, Boscovich's third volume of the *Elementa* contained a non-elementary treatise on conics, as may be inferred from the first two volumes. Moreover, in its second part, Boscovich also entered into difficult speculations concerning the transformation of the

⁶¹ (Boscovich 1757), see also (Pepe 2010).

⁶² The first volume of the *Elementa* was translated almost entirely in Italian by Luigi Panizzoni and published in 1774. See (Pepe 2010, 16).

⁶³ More information concerning the mathematical treatises of the second half of the eighteenth century in Italian in (Pepe 2010, 23-24).

⁶⁴ In addition to the *Compendio*, Grandi published the *Le Istituzioni delle sezioni coniche*, first written in Latin (Naples 1737), then translated into Italian (Florence 1744, Venice 1746).

geometrical loci, and the introduction of imaginary objects into geometry, prefiguring some aspects of “a new geometry” that would come to light only many decades later.⁶⁵

As regards the French scientific milieu, Boscovich had excellent relations with the astronomer Joseph Jérôme de Lalande, who esteemed his astronomical achievements so much that described Boscovich’s method for determining the elements of the sun’s rotation around its axis, when three positions of a sun-spot were known, in the second volume of the *Astronomie* (1764).

Lalande, also greatly admired Boscovich’s mathematical work. In fact, referring to the *Sectionum Conicarum Elementa*, he wrote:

This treatise forms the third volume of his Elements of Mathematics; the genius of the author appears just as much as in his most sublime works; his way of looking at conic sections in general, and in particular, of proving their osculating radii, and their other most difficult properties, is evidence of a profound geometer who deserves, even in the smallest things, his long-standing reputation as one of the greatest mathematicians of our century, and it is the most inquiring treatise we have seen on conic sections.⁶⁶

However, despite Lalande’s admiration, Boscovich was not so popular with the French academicians. On the occasion of his third journey to Paris, in 1774, he could not be appointed member of the Academy, mainly due to the hostility of d’Alembert, who had great influence inside the Institute. According to Rigutti (2010, 21), this was because inside the Academy many mathematicians were greatly interested in celestial mechanics, a field to which Boscovich made no substantial contributions, and, moreover, they considered the methods of differential and integral calculus superior to the old geometrical ones.

Boscovich’s *Elementa* was well received in the German speaking catholic countries from Austria to Silesia, and many didactic works were inspired, more or less directly, by Boscovich’s work (Pepe 2010, 28). Boscovich had very close relationships with his co-brothers of the Jesuit College in Vienna, among whom: Karl Scherffer (1716-1783), professor of philosophy and mathematics; the mathematician and astronomer, Joseph Xaver Liesganig (1719-1799), director of the Observatory; the cartographer, Georg Ignaz Metzburg (1735-1829), who published a work which was clearly influenced by Boscovich (Metzburg 1780-1791). In particular, in the second volume of this work, he included the *Elementa sectionum conicarum* (Metzburg 1783) where the definition of a conic section is given both as a section of a cone, and in the plane, similar to Boscovich’s definition.

It was in the English-speaking countries that Boscovich’s treatise on conic sections received greater interest. It is generally agreed that English physicists of the nineteenth century looked with interest at Boscovich’s theory of matter. The reception of his ideas in natural philosophy in Great Britain, as well as the relations between the Jesuit and the English scientific community, have been widely investigated.⁶⁷ According to Feingold (1993), the reason why Boscovich become so influential and enjoyed such popularity was because his ideas became “an integral part of the reigning Newtonian tradition”, and the British also viewed him as the great Continental ambassador of Newtonian ideas.

⁶⁵ See for instance (Del Centina, Fiocca 2018), and the references therein.

⁶⁶ “ce Traité fait le troisième Volume de ses Elémens de Mathématiques ; le génie de l’Auteur y brille autant que dans ses Ouvrages les plus sublimés ; sa manière de considérer les Sections coniques en général & en particulier, de démontrer leurs rayons osculateurs, & leurs autres propriétés les plus difficiles, fait voir un Géomètre profond qui justifie dans les moindres choses la réputation qu’il a depuis long-temps d’un des plus grands Mathématiciens de notre-siècle, & forme le Traité le plus curieux que nous ayons vû sur les Sections Coniques ”, *Journal des Sçavans*, Avril 1766, p. 240.

⁶⁷ Five contributions concerning this subject are included in (Boscovich 1993).

It is not surprising, therefore, that Boscovich's treatise on conic sections was also well received there. One more reason for the fortune of this work in those countries, was that it represented the most appropriate introduction to Newton's *Principia*, for its entirely geometrical style was very close to Newton's. Several authors founded their treatises on conic sections upon the properties of the determining ratio, and also introduced the eccentric circle, also called the "generating circle", T. Newton, and G. Walker in 1794, J. Leslie in 1821, S. H. Haslam, J. Edwards and C. Taylor in 1881, were among them.

The work on conic sections by Thomas Newton (- 1843), fellow at the Jesus College of Cambridge, was, in fact, designed to be an introduction to Newton's *Principia* and was drawn up for the use of the author's pupils, some of whom, he writes, entered upon Newton's *Principia* with little or no previous knowledge of conics. He commented on Boscovich's *Elementa Matheseos* as "a work which seems to have been little known, or not so much esteemed as it deserves, although the author is justly celebrated for his later productions" (Newton 1794, iv). According to T. Newton, Boscovich's *Elementa* have all the advantages of the works by those authors who have defined the conics as sections of the cone, without any of the disadvantages. In the *Elementa* he found the plan that, to a great extent, he had developed, and he adopted many of Boscovich's proofs and demonstrations, though he altered the disposition of the propositions. T. Newton introduced the eccentric circle, but without giving it any name, in the demonstration of proposition XXIX, to draw the tangents to a conic section from any given point outside it, except the centre of the hyperbola (1794, 39).

As far as George Walker (1734-1807) of Nottingham is concerned, he believed he was the first to discover the eccentric circle, that he called "generating circle", and to describe its properties, and, according to him, already thirty years before the publication of his book (Walker 1794, v). In the preface he wrote that he had discovered it as an immediate consequence of the property of conics exhibited in proposition 24 of Newton's *Arithmetica Universalis*, adding that

these sections have more connection with the Circle than with the Cone, nor is it any thing wonderful that it should be so, since the Circle is the principal element from which the Cone itself is generated. The circle being therefore the common genesis of the three sections, the properties which are common to them all are deduced from the common source in one common demonstration, to a much greater extent than in any treatise which deduce the section from the Cone.

The Scotsman John Leslie (1766-1832), professor of natural philosophy and formerly of mathematics at the University of Edinburgh, chose to base his work *Geometrical Analysis and Geometry of Curve Lines* (1821) on "the beautiful property noticed by Pappus in his *Mathematical Collections*, and investigated by Newton himself in his *Arithmetica Universalis*", and, in the preface, he credited "the celebrated Boscovich" with being the first to have composed a treatise on conic sections based on this principle, which, he wrote, "consisted of only a few propositions, but drawn out into a string of corollaries".⁶⁸ We stress that Leslie's work was designed as an introduction to the study of natural philosophy.

In 1881, Charles Taylor (1840-1908) fellow at St John's College in Cambridge, published *An introduction to the ancient and modern geometry of conics*, which included an extended historical introduction ranging from the Greek geometers to Newton, and the modern geometry including Boscovich, Poncelet, and Chasles. Taylor referred to Boscovich's treatise as "a clear and compact treatise, which for simplicity, depth and suggestion will not readily be surpassed" (1881, lxxii).

⁶⁸ Erroneously Leslie indicated the 1744 as the year of publication of Boscovich's treatise on conic sections.

Three years later, Taylor came back to this subject by reading a paper on the geometry of conics at the Association for the Improvement of the Geometrical Teaching,⁶⁹ with the aim of giving some suggestions to the teachers in developing the subject of conic sections. In his speech, he advanced the idea of adopting a historical order “following the example of Boscovich, I would define a conic as the locus of a point whose distances from a fixed point or focus and a fixed straight line, or directrix, are in a constant ratio, and would make use of what I have proposed to call the eccentric circle in tracing the conics, and proving some of their general properties once and for all”. According to Taylor, this path would have provided the easiest transition from the most elementary to the higher geometry (Taylor 1884, 46).

S. Holker Haslam and Joseph Edwards, scholar and fellow, respectively, at the Sidney Sussex College in Cambridge, in their joint work (1881) called the eccentric circle “Auxiliary Circle of a Point”. They stressed the advantage of this construction “especially from the very general theorem of art. 18; it also shows very clearly the intrinsic relation which the three species of conics bear to one another *and to the circle*”. In fact, they noticed that this construction led to a method of plane projection which was very simple and more powerful than central projection (conical projection in their words), which they called “Focal Projection”. The cited art. 18 corresponds to Boscovich’s proposition VI (the chords theorem), judged by the authors as “the most general, and, consequently, the most important theorem in the whole theory of conics, and nearly all the other propositions in conics will be particular cases of this, or may be easily deduced from it”.

After the publication of Taylor’s book, the eccentric circle of Boscovich became very popular among English-language mathematicians. In 1885, John Casey (1820-1891), professor of Mathematics and Mathematical Physics at the Catholic University of Ireland, in an analytical treatise of the conic sections proposed, as exercises, some results concerning the so called “Boscovich’s circle” (Casey 1885, 167, 206).

Charles Smith (1844-1916), teacher at the Sidney Sussex College, of Cambridge, also made use of “the eccentric circle of Boscovich” to obtain the proof of the chords theorem in (1894).

The same year 1894, Eduard M. Langley (1851-1933), professor of mathematics at Bedford Modern School and founder of the *Mathematical Gazette*,⁷⁰ with his article *The eccentric circle of Boscovich* (1894) aimed to draw attention to Boscovich’s method of transformation. In particular, Langley showed how this method had striking analogies with the method of perspective transformation (i.e. central projection), and a simple connection with it. We reserve comments on this argument for another paper.

6 FINAL REMARKS AND CONCLUSION

With the third volume of the *Elementa universae matheseos*, Boscovich ended his production on pure mathematics, and his project to write on the applications of mathematics to other sciences, following the example of the *Cursus seu mundus mathematicus* by C. F. Millet Dechales, did not come about. Boscovich’s interests turned mainly to natural philosophy. As early as 1748, when he was composing the *Dissertatio de lumine*, Boscovich had outlined the whole of his theory of natural

⁶⁹ We notice that this Association was founded in 1876 by a number of mathematicians who, “from experience as teachers reached the conviction that Euclid was not a suitable introduction to geometry for the ordinary immature minds”.

⁷⁰ The journal devoted to elementary mathematics of the Association for the Improvement of Geometrical teaching. Langley is also known for having inspired Eric. T. Bell to continue to study mathematics.

philosophy, exposed ten years later in (Boscovich 1758), comprising his hypothesis on the structure of matter, and the attempt to reduce to a unique universal mathematical law all forces acting in nature (Casini 1983, 169-170). Personal events which occurred towards the end of the 1740s, such as the measurement of the arc of meridian between Rome and Rimini, the work on the cracks to the dome of S. Peter in Rome, and diplomatic missions outside the Vatican State, diverted him from his project.

As we said above, the success of Boscovich's *Elementa universae matheseos* was not long-lasting. The high-level discussion of conic sections, and the very abstract dissertation on the transformations of curves he wanted to add, made the third volume not very easy to read, at least for students, though it was clearly written with didactic purposes. The structure of the *Sectionum Conicarum Elementa* – with many definitions, and important theorems, often scattered inside the many corollaries and scholia –, and the complementariness with the *Dissertatio de transformatione locorum geometricorum* – as attested by the frequent cross-references from one to the other –, made the reading of this work quite difficult.

Thus, after the suppression of the Jesuit order, the decline of Latin as a common teaching language in colleges and schools, and, at the same time, the increasing dominance of the use of analytic methods in geometry, Boscovich's treatise on conic sections was forgotten soon after its appearance.

In our opinion, Boscovich's *Sectionum Conicarum Elementa* is not at all an elementary treatise on conic sections. It presents notable originality in the presentation of the theory, and elements of outstanding originality, above all the introduction of the eccentric circle. With this treatise Boscovich aimed at expounding the theory of conic sections from a unifying point of view. Certainly, he drew inspiration from the geometrical results in Newton's *Principia*, but, as J.-V. Poncelet (1822, 18-20) later did, Boscovich recognized the fundamental role of the chords theorem, and, in fact, at first he wanted to base his treatise on this property. Later, once he had discovered the eccentric circle, he put it at the basis of the whole theory.

However, in his book, Boscovich omitted to treat the four lines problem of Pappus, and the organic construction of conics, as Newton had instead done in the *Principia*. He most likely thought the eccentric circle – the original feature of his work – would suffice to attract interest in his treatise.

There was another element of novelty in Boscovich's treatment of conic sections. He transformed one conic into another by "moving" it inside a continuous plane system, rather than by "projection and section" passing through space. But, likely for this reason, although the principle of continuity was available to him as expressed in the *Dissertatio de transformatione locorum geometricorum*, and he had somehow anticipated the idea of "conservation of functional relation", he was unable to give the theory of conics the direction later impressed on it by Poncelet.

It is well-known that Chasles proved the equivalence among the conditions for six points to be on a conic, Pappus' four lines problem, Newton's organic construction, Desargues' theorem on the quadrilateral, and Pascal's theorem on the hexagon, with his anharmonic property of points on a conic, so recognizing their common projective value (Chasles 1837, 334-339). In this way, Chasles also showed their equivalence with the chords theorem, and, as a consequence, Boscovich's foresight. Unfortunately, he cited Boscovich only once, and not his work on conics (1837, 433).

The synthetic approach, and the adoption of many of Newton's ideas, ensured in England the success that Boscovich's work did not enjoy in Europe. The interest in the *Sectionum Conicarum*

Elementa had a double value: on the one hand, at the turn of the eighteenth century, Boscovich's treatise seemed the best introduction to the reading of the *Principia*, and, as such, it was taken as a model by various authors in composing their own treatises; on the other, at the end of the nineteenth century, thanks to C. Taylor, the significance of Boscovich's work as a didactic tool was recognized in the teaching of conic sections.

When Langley noted the striking analogy between the plane transformation connected with Boscovich's construction of conic sections by means of the eccentric circle and the central projection, it was too late; projective geometry was at its apex, and there was no place for Boscovich's ideas and speculations on the eccentric circle outside of history.

REFERENCES

Apollonius of Perga, 1566. *Conicorum Libri Quatuor. Cum commentariis Federici Commandini*. Bononie: A. Benatii.

Apollonius of Perga, 1896. *Treatise on Conic Sections*, ed. T.L. Heath. Cambridge: Cambridge University Press.

Apollonius of Perga, 1959. *Les Coniques, œuvres traduites pour la première fois du Grec en Français par P. Ver Eecke*. Paris: Albert Blanchard.

Boscovich, R.J. 1740. *De circulis osculatoris dissertatio*. Romae: ex typographia Komarek.

Boscovich, R.J., 1741. *De inaequalitate gravitatis in diversis Terrae locis*. Romae : ex typographia Komarek.

Boscovich, R.J., 1743. *De motu corporis attracti in centrum immobile viribus decrescentibus in ratione distantiarum reciproca duplicata in spatiis non resistentibus*. Romae : ex typographia Komarek.

Boscovich, R.J., 1744. *Nova methodus adhibendi phasium observationes in eclipsibus lunaribus ad exercendam Geometriam, & promovendam Astronomiam*. Romae: ex typographia Komarek.

Boscovich, R.J., 1746. Dimostrazione facile d'una principale proprietà delle Sezioni Coniche, la quale non dipende da altri teoremi Conici; e disegno d'un nuovo metodo di trattare quella dottrina. *Giornale de' Letterati* Art. XIX giugno e luglio 1746: 189-193, 241-243, 315-316.

Boscovich, R.J., 1747. *De maris aestu*. Romae: ex typographia Komarek.

Boscovich, R.J., 1752. *Elementa Universae Matheseos*. 2 vols. Romae: Salomoni.

Boscovich, R.J., 1754. *Elementa Universae Matheseos*, 3 vols. Romae: Salomoni.

Boscovich, R.J., 1754a. Sectionum Conicarum Elementa, nova quadam methodo concinnata. In (Boscovich 1754, III, 1-296).

Boscovich, R.J., 1754b. Dissertatio de transformatione locorum geometricorum. In (Boscovich 1754, III, 297-468).

- Boscovich, R.J., 1757. *Elementa Universae Matheseos*, 3 vols. Venetiis: Perlini.
- Boscovich, R.J., 1758. *Philosophiae naturalis theoria redacta ad unicam legem virium in natura existentium*. Viennae: Officina libraria Kaliwodiana.
- Boscovich, R.J., 1993. *R.J. Boscovich, Vita e attività scientifica/ His life and Scientific Work*, ed. Piers Bursill-Hall. Roma: Istituto della Enciclopedia Italiana.
- Boscovich, R.J., 2012. Carteggio con Natale Boscovich (1730-1758). In *Edizione Nazionale delle Opere e della Corrispondenza di Ruggiero Giuseppe Boscovich. Corrispondenza* vol. III, tomo I, a cura di Edoardo Proverbio. <http://www.edizionenazionaleboscovich.it/>
- Boscovich, R.J., Le Seur, T., Jacquier, F., 1742. *Parere di tre matematici sopra i danni che si sono trovati nella cupola di S. Pietro sul fine dell'anno MDCCXLII*. Roma.
- Boscovich, R.J., Le Seur, T., Jacquier, F., 1743. *Riflessioni sopra alcune difficoltà spettanti i danni e risarcimenti della cupola di S. Pietro*. Roma.
- Boscovich, R.J., Maire, C., 1755. *De litteraria expeditione per pontificiam ditionem ad dimetiendos meridiani gradus et corrigendam mappam geographicam*. Roma: N. and M. Plearini.
- Brackenridge J.B., Nauenberg M., 2002. Curvature in Newton's dynamics. In *The Cambridge companion of Newton*, eds. I.B. Cohen and G.E. Smith. Cambridge: Cambridge University Press, 85-137.
- Bussotti P., Pisano R., 2014. On the Jesuit Edition of Newton's *Principia*. Science and Advanced Reserches in the Western Civilization. *Advances in Historical Studies*, 3 (1): 33-55.
- Casey, J., 1885. *A treatise on the analytical geometry of the point, line, circle, and conic sections, containing an account of its most recent extensions, with numerous examples*. Dublin: Hodges, Figgis and Co.
- Casini, P., 1983. *Newton e la coscienza europea*. Bologna: Il Mulino.
- Chasles, M., 1837. *Aperçu historique sur l'origine et le développement des méthodes en géométrie*. Paris : Gauthier-Villars.
- Crescimbeni, G.M., 1711. *Storia dell'Accademia degli Arcadi istituita in Roma l'anno 1690*. Roma: Antonio De Rossi.
- Del Centina A., 2016. On Kepler's system of conics in *Astronomiae par Optica*. *Archive for Hist. of Ex. Sciences*, 70: 567-589.
- Del Centina, A., Fiocca, A., 2018. Boscovich's geometrical principle of continuity and the "mysteries of the infinity". *Historia Mathematica*, 45 (2): 131-175.
- Feingold, M., 1993. A Jesuit among the Protestants: Boscovich in England c. 1745-1820. In (Boscovich, 1993, 511-526).
- Field J.V., 1986. Two mathematical inventions in Kepler's *Ad Vitellinem Paralipomena*. *Hist. and Phil. Of Science*, Part A, 17, 449-468.
- Guarini G., 1671. *Euclides adauctus et methodicus mathematicaque universalis*. Augustae Taurinorum: B. Zapatae.
- Guicciardini N., 1999, *Reading the Principia, the Debate on Newton's Mathematical Methods for Natural Philosophy from 1687 to 1736*. Cambridge: Cambridge Univ. Press.

- Guicciardini N., 2011. *Isaac Newton on Mathematical Certainty and Method*. Cambridge, Massachusetts: MIT Press.
- Guicciardini N., 2015. Editing Newton in Geneva and Rome: The Annotated Edition of the Principia by Calandrini, Le Seur and Jacquier. *Annals of Science*, 72 (3): 37-380.
- Haslam, S. H., Edwards, J., 1881. *Conic Sections Treated Geometrically*. London: Longmans Green and Co.
- Huygens, C. 1673. *Horologium oscillatorium sive de motu pendulorum ad horologia aptatu demonstrationes geometricae*. Paris: Apud F. Muguet.
- L'Hospital, G.F.A. de, 1707. *Traité analytique des sections coniques et de leur usage pour la résolution des équations dans les problèmes tant déterminés qu'indéterminés*. Paris : Chez la veuve de Jean Boudot et Jean Boudot fils.
- La Hire, Ph., 1685. *Sectiones Conicae, in novem libros distributae*. Paris : S. Miclallet.
- Lalande, J.-J. Lefrançois de, 1764. *Astronomie*. Tome second. Paris : Chez Desaint & Saillant.
- Langley, E.M., 1894. The Eccentric Circle of Boscovich. *The Mathematical Gazette*, 1: 1-3; 3: 17-19.
- Leibniz, G.W., 1686. Meditatio nova de natura anguli contactus et osculi, *Acta Eruditorum Anno MDCLXXXVI*: 289-292.
- Le Poivre, J.-F., 1704. *Traité des sections du cylindre et du cône considérées dans le solide et dans le plan*. Paris, Barthelemy Girin.
- Le Poivre, J.-F., 1708. *Traité des sections du cône considérées dans le solide, avec des démonstrations simples et nouvelles, plus simples et plus générales que celles de l'édition de Paris*. Mons: G. Migeot.
- Leslie, J., 1821. *Geometrical Analysis, and Geometry of Curve Lines, being Volume Second of A Course of Mathematics, and Designed as an Introduction to the Study of Natural Philosophy*. Edinburgh: W. & C. Tait.
- Metzburg, G.I., 1780-1791. *Institutiones mathematicae in usum tironum conscriptae*. Editio tertia. 7 vols. Viennae: Typis Johan. Thomae nob. De Trattnern.
- Metzburg, G.I., 1783. Elementa sectionum conicarum. In (Metzburg 1780-1791, vol. II, 151-200)
- Milne, J.J., 1927. Newton's Contribution to the Geometry of Conics. In *Isaac Newton 1642-1727: a memorial volume edited for the Mathematical Association*, ed. W. J. Greenstreet, 96-114. London: Bell & Sons.
- Newton, I., 1687. *Philosophiae Naturalis Principia Mathematica*. Typis Josephi Streater, Londini.
- Newton, I., 1707. *Arithmetica Universalis*. Cantabrigiae: Typis Academicis.
- Newton, I., 1726. *Philosophiae Naturalis Principia Mathematica, editio tertia aucta & emendata*. Londini : Apud Guil. & Joh. Innys.
- Newton, I., 1739-42. *Philosophiae Naturalis Principia Mathematica, perpetuis commentariis illustrata, communi studio PP. Thomae Le Seur & Francisci Jacquier ex Gallicana Minimorum Familia, Matheseos Professorum* 3 vols. Geneve: typis Barillot.

- Newton, I., 1967-81. *The Mathematical Papers of Isaac Newton*, ed. D.T. Whiteside, 8 vols. Cambridge: Cambridge University press.
- Newton, T., 1794. *A Short Treatise on the Conic Sections in which the three curves are derived from a general description on the plane and the most useful properties of each are deduced from a common principle*. Cambridge: John Archdeacon and John Burges.
- Pappus d'Alexandrie, 1588. *Mathematicae Collectiones a Federico Commandino Urbinate in latinum conversae et commentaris illustratae*. Venetiis : Apud Franciscus de Franciscis Senensem.
- Pedley, M., 1993. "I Due Valentuomini Indefessi": Christopher Maire and Roger Boscovich and the Mapping of the Papal States (1750-1755). *Imago Mundi*, 45, 59-76.
- Pepe, L., 2010. Introduzione. In *Edizione nazionale delle opere e della corrispondenza di Ruggiero Giuseppe Boscovich, Opere a stampa* volume II, 11-28. <http://www.edizionenazionaleboscoivich.it/>
- Pepe, L., 2016. *Insegnare matematica. Storia degli insegnamenti matematici in Italia*. Bologna: Clueb.
- Poncelet, J.-V., 1822. *Traité des propriétés projectives des figures*. Paris : Bachelier.
- Rigutti, M., 2010. Introduzione. In *Edizione nazionale delle opere e della corrispondenza di Ruggiero Giuseppe Boscovich, Opere a stampa* volume V/V, 11-37. <http://www.edizionenazionaleboscoivich.it/>
- Saint-Vincent, G. 1647. *Opus geometricum quadraturae circuli et sectionum conii decem libris comprehensum*. Antverpia: Apud Ioannem et Iacobum Meursios.
- Smith, C., 1894. *Geometrical Conics*. London: Macmillan and Co.
- Stirling, J., 1717. *Lineæ Tertii Ordinis Neutonianæ, Sive Illustratio Tractatus D. Neutoni de Enumeratione Linearum Tertii Ordinis, Cui Subjungitur, Solutio Trium Problematum*. Oxoniæ: Ex Theatro Sheldoniano.
- Tacquet, A., 1745. *Elementa Euclidea Geometriae Planæ, ac Solidæ; et Selecta ex Archimede Theoremata: eiusdemque Trigonometria Plana, Plurimis Corollariis, Notis, ac Schematibus quadraginta illustrata a Gulielmo Whiston; quibus nunc primum accedunt Trigonometria Sphærica Rogerii Josephi Boscovich S.J. & Sectiones Conicæ Guidonis Grandi, Annotationibus satis amplis Octaviani Cameti explicatæ*. 2 vols. Romæ: Hieronymi Mainardi.
- Taylor, C., 1881. *An Introduction to the Ancient and Modern Geometry of Conics*. Cambridge: Deighton Bell and co.
- Taylor, C., 1884. The Discovery and the Geometrical Treatment of the Conic Sections. In *Tenth General Report of the Association for the Improvement of Geometrical Teaching*, 43-55. Birmingham: Herald Press.
- Walker, G., 1794. *A Treatise on the Conic Sections*. London: Charles Dilly.

Andrea Del Centina, Dipartimento di Matematica e Informatica, Università di Ferrara, via Machiavelli 35, 44121, e-mail cen@unife.it

Alessandra Fiocca, Dipartimento di Matematica e Informatica, Università di Ferrara, via Machiavelli 35, 44121, e-mail fio@unife.it