

## MAJOR ARTICLE

# Multiple Human Herpesvirus-8 Infection

Mohammed M. Beyari,<sup>1,2</sup> T. A. Hodgson,<sup>1</sup> R. D. Cook,<sup>1,2</sup> W. Kondowe,<sup>3</sup> E. M. Molyneux,<sup>3</sup> C. M. Scully,<sup>1</sup> C. G. Teo,<sup>2</sup> and S. R. Porter<sup>1</sup>

<sup>1</sup>Department of Oral Medicine, Eastman Institute for Oral Health Care Sciences, University College London, and <sup>2</sup>Virus Reference Division, Central Public Health Laboratory, Public Health Laboratory Service, London, United Kingdom; <sup>3</sup>Department of Paediatrics, College of Medicine, University of Malawi, Blantyre, Malawi

**In Malawian patients with Kaposi sarcoma (KS) and their relatives, we investigated nucleotide-sequence variation in human herpesvirus-8 (HHV-8) subgenomic DNA, amplified from oral and blood samples by use of polymerase chain reaction. Twenty-four people had amplifiable HHV-8 DNA in >1 sample; 9 (38%) were seropositive for human immunodeficiency virus type 1, 21 (88%) were anti-HHV-8-seropositive, and 7 (29%) had KS. Sequence variation was sought in 3 loci of the HHV-8 genome: the internal repeat domain of open-reading frame (ORF) 73, the KS330 segment of ORF 26, and variable region 1 of ORF K1. Significant intra-person/intersample and intrasample sequence polymorphisms were observed in 14 people (60%). For 3 patients with KS, intraperson genotypic differences, arising from nucleotide sequence variations in ORFs 26 and K1, were found in blood and oral samples. For 2 other patients with KS and for 9 people without KS, intraperson genotypic and subgenotypic differences, originating predominantly from ORF K1, were found in oral samples; for the 2 patients with KS and for 4 individuals without KS, intrasample carriage of distinct ORF K1 sequences also were discernible. Our findings imply HHV-8 superinfection.**

Human herpesvirus-8 (HHV-8), also known as Kaposi sarcoma (KS)-associated herpesvirus, is etiologically linked to KS, multicentric Castleman disease, and primary effusion lymphoma. Its endemicity in general populations, as assessed by seroprevalence studies, is low in North America and Northern Europe (<20%) but much higher in some regions around the Mediterranean and in Africa (20%–60%) [1].

In Africa, HHV-8 commonly is acquired in childhood. Transmission tends to be intrafamilial, and the dominant route is from mother to child [2]. Extrafamilial nonsexual transmission also has been identified [3, 4]. Studies among homosexual men in North America implicate the mouth and oropharynx as dominant sites of HHV-8 shedding and saliva as an important vehicle of HHV-8 transmission [5]. Two recent reports show that, in Africa, too, HHV-8 has a predilection to

be shed in saliva. The first is a study of Egyptian children with acute fever not due to a specific viral exanthem, in which significantly more children were found to have HHV-8 DNA in saliva but not in blood than to have HHV-8 DNA in blood but not in saliva [6]. The second report relates to our earlier study conducted in Malawi of asymptomatic family members of patients with KS whose HHV-8 genome detection rate was found to be significantly higher in oral than in blood samples [3].

Saliva or saliva-contaminated objects might facilitate the intra- and extrafamilial spread of HHV-8 in African communities. Assuming that, in these communities, the main portal of entry of HHV-8 is the mouth, exposure of susceptible persons to the virus is likely to begin early in life. Although it is unclear how immunological responses generated by the host after first exposure protect against infection from subsequent exposures, it would appear that humoral responses may not be neutralizing, because HHV-8 can actively replicate in people who are seropositive for the virus [7]. Accordingly, people growing up and living in regions where HHV-8 is hyperendemic are potential hosts to multiple HHV-8 strains. We tested for the presence of the HHV-8 genome in blood and several different oral compart-

Received 19 February 2003; accepted 1 April 2003; electronically published 22 August 2003.

Reprints or correspondence: Dr. Mohammed M. Beyari, Dept. of Oral Medicine, Eastman Institute for Oral Health Care Sciences, University College London, 256 Gray's Inn Rd., London WC1X 8LD, UK ([mbeyari@eastman.ucl.ac.uk](mailto:mbeyari@eastman.ucl.ac.uk)).

**The Journal of Infectious Diseases** 2003;188:678–89

© 2003 by the Infectious Diseases Society of America. All rights reserved.  
0022-1899/2003/18805-0008\$15.00

ments, in a group of people residing in Malawi, and evaluated the extent to which, in each person, the genomes found in one compartment diverge from those in another.

## PATIENTS, MATERIALS, AND METHODS

**Patients and samples.** The study group included patients with KS ( $n = 22$ ) attending the Central Hospital of Blantyre, Malawi, and their first-degree relatives ( $n = 67$ ), a group of subjects described in detail elsewhere [3, 4]. Ethical approval for the study was granted in the United Kingdom and locally. Venous blood and oral samples were obtained after informed consent was given. The following oral samples were collected: mouth rinse, throat gargle, and palatal exfoliate. A sampling order of the oral components was imposed to minimize cross-contamination between compartments: the throat-gargle sample (collected after 30 s of gargling with 5 mL of PBS), the mouth-rinse sample (collected after retaining 5 mL of PBS in the mouth for 2 min, during which gentle lateral flexions of the neck were encouraged), and the palatal-exfoliate sample (collected in 1 mL of PBS after applying 5 rotations of an exfoliative cytology brush to the palatal mucosa posterior to the upper incisors). All oral specimens were stored at  $-70^{\circ}\text{C}$  until further processing.

**Sample processing.** After separation of plasma from the blood samples,  $\text{CD45}^{+}$  leukocytes were immunomagnetically fractionated using Dynabeads (Dyna A.D.), as described elsewhere [8], and were stored at  $-70^{\circ}\text{C}$ . DNA was extracted from the fractionated leukocytes by use of GeneClean III (BIO 101). Oral samples were subjected to low-speed centrifugation, after which the pellets were resuspended in 1 mL of PBS, split into  $150\text{-}\mu\text{L}$  aliquots, and stored at  $-70^{\circ}\text{C}$  until required. DNA was extracted from each aliquot by use of the QIAamp kit (Qiagen).

**Length polymorphism and restriction fragment-length polymorphism (RFLP) analyses of HHV-8 DNA amplified from the open-reading frame (ORF) 73 internal repeat domain (IRD).** A nested polymerase chain reaction (PCR) protocol was applied to sample extracts to amplify a DNA segment from the IRD of ORF 73, as described elsewhere [4]. This segment (hereafter referred to as "IRD") varies in length from 1350 to 1900 bp [9]. To further evaluate sequence polymorphism within IRD, PCR products were digested with *Ban*II and *Mbo*I, after which the digested products were electrophoresed, and the gel migration distances of the products were analyzed [4].

**Sequencing analyses of HHV-8 DNA amplified from ORFs 26 and K1.** A 211-bp segment from the KS330 region of ORF 26 (hereafter referred to as "KS330"), spanning positions 355–588, was amplified from sample extracts by use of nested PCR, as described elsewhere [10] (KS330 position assignments are based on the prototype HHV-8 sequence; GenBank accession no. U75698). A 246-bp segment of ORF K1 that encom-

passes the highly variable V1 region [11] (hereafter referred to as "K1/V1"), spanning positions 366–577, was amplified from sample extracts by use of nested PCR, as described elsewhere [3] (K1/V1 position assignments are based on the BCBL-1 HHV-8 sequence; GenBank accession no. U86667). Genotypic assignments based on KS330 were made according to the protocol of Poole et al. [12]; assignments based on K1/V1 were made according to the protocol of Zong et al. [11]. To minimize contamination during PCR, DNA extraction, PCR reagent preparation, thermocycling, and post-PCR procedures were conducted in dedicated rooms. Appropriate negative and positive control specimens were included in each PCR. In addition, DNA extraction and PCR were repeated for those samples showing intraindividual HHV-8 subgenomic sequence variation. PCR products were sequenced using the Beckman-Coulter CEQ2000 automated capillary array sequencer. Raw DNA sequence data were analyzed using SeqMan software (DNASTar), and phylogenetic analyses were performed using PHYLIP (version 3.5; available at: <http://evolution.genetics.washington.edu/phylip.html>).

**Screening for intrasample K1/V1 sequence differences by denaturing gradient gel electrophoresis (DGGE).** From each person, samples that amplified positively for K1/V1 and for which sequences differed between body compartments were subjected again to nested PCR by use of the EXPAND High Fidelity PCR System (Roche Diagnostics). Clones were generated from each K1/V1 PCR product by use of the TOPO TA Cloning System (Invitrogen). For each colony, another round of PCR was done under conditions identical to the second-round high-fidelity PCR, except that a "clamping" primer was used in place of the inner sense primer, which contains a guanine-cytosine rich domain with a high melting temperature, to prevent complete denaturation of the PCR product. This primer has the sequence 5'-CGCCCGCCGCGCCCGCGCCCGTCCCGCCGCCCGCCCGGGAGTGATTCAACGC-3'.

DGGE polyacrylamide gels were prepared as described elsewhere [13]. Preliminary experiments showed that, to achieve a 1-bp discrimination between the K1/V1 colony PCR products, the gel gradient needs to contain 30%–50% of denaturants. A 50% solution consists of 10% acrylamide, 0.6% TRIS-acetate-edetic acid (TAE) buffer, 20% formamide, and 3.5 mol/L urea, whereas a 30% solution consists of 10% acrylamide,  $0.6\times$  TAE, 12% formamide, and 2.1 mol/L urea. To prepare a gradient gel, 30 mL of each solution, each containing 13  $\mu\text{L}$  of N, N, N', N'-tetramethylethylenediamine and 250  $\mu\text{L}$  of 10% ammonium persulfate, was pumped between glass plates of the Ingeny Phor U2 vertical electrophoresis apparatus (GRI), with the aid of a gravity-driven gradient maker with pumped drive. A 48-well comb was inserted into the gel, which then was left to polymerize. DGGE experiments were conducted such that a single gel accommodated, for each sample of a given person, up to

15 “clamped” K1/V1 PCR products. Each product (2  $\mu$ L) was mixed with an equal volume of Orange G loading buffer and loaded into the wells, after which gel electrophoresis was carried out in 0.6 $\times$  TAE buffer at 60°C and 100 V for 18 h. The gel then was stained in SYBR Green I (Flowgen; Ashby de la Zouch), and DNA bands were visualized by UV transillumination. K1/V1 inserts in clones corresponding to bands that migrate to disparate gel positions were sequenced for genotypic and subgenotypic differences. For the purpose of this study, subgenotypic differences were considered to be significant (i.e., indicating that the differences are due to the sequences that originated from distinct virus strains) if the divergence between K1/V1 sequences was  $\geq$ 5%.

## RESULTS

**Patient and sample characteristics.** Figure 1 summarizes the characteristics of 24 (27%) of the 89 people who were found to carry amplifiable HHV-8 subgenomic DNA in >1 sample. Thirteen (54%) of the 24 were male. Patients with index cases of KS are assigned the “i” suffix, and their family members were assigned numerals; letters denote family assignments. Ages ranged between 2 and 44 years (mean, 18 years). Seven (29%) patients had KS, 9 (38%) patients were human immunodeficiency virus (HIV) type 1–seropositive, and 21 (88%) patients were HHV-8 seropositive. The rate of HHV-8 subgenomic DNA detectability varied according to the type of sample and the target of amplification within the HHV-8 genome (figure 1). In mouth-rinse samples, the detectability rates were 38% for IRD, 75% for KS330, and 92% for K1/V1 DNA; in throat-gargle samples, the detectability rates were 22% for IRD, 48% for KS330, and 74% for K1/V1 DNA; in palatal-exfoliate samples, the detectability rates were 0% for IRD, 38% for KS330, and 50% for K1/V1 DNA; and, in blood samples, the detectability rates were 4% for IRD, 17% for KS330, and 21% for K1/V1 DNA. The detectability rates according to the number of amplifiable subgenomic DNA segments were as follows: for all 3 segments, 33% for mouth-rinse samples, 22% for throat-gargle samples, 4% for blood samples, and 0% for palatal-exfoliate samples; with at least 2 segments, 42% for mouth-rinse samples, 26% for throat-gargle samples, 21% for palatal-exfoliate samples, and 13% for blood sample; and, with at least 1 segment, 46% for palatal-exfoliate samples, 26% for throat-gargle samples, 21% for mouth-rinse samples, and 4% for blood samples.

**IRD length polymorphism and RFLP.** Figure 2 shows electrophoretic banding patterns of IRD PCR products derived from 5 people from whom products could be amplified from >1 sample. Length polymorphisms of the products are displayed in the upper panel, whereas RFLPs are shown in the lower panel. Intraperson length polymorphism and RFLP were absent

in all patients except 1, T2, in whom the IRD amplicons generated from his mouth-rinse and throat-gargle samples were polymorphic for length, both without and with *Ban*II and *Mbo*I restriction.

**Differences in KS330 consensus sequences.** For 16 people, KS330 DNA could be amplified from at least 2 samples, and, for 5 people (Ci, Fi, Ki, T2, and W4), KS330 DNA was amplifiable from 3 samples. The sequences, which are deposited in GenBank (accession nos. AY219429–AY219458), cluster with ORF 26 sequences of known African HHV-8 strains [12]. Identical KS330 sequences were observed in the samples from 9 people (B5, Ci, E6, Fi, G2, K1, W2, X1, and Z2). Nonidentical sequences were found in samples from 6 subjects (E4, Ki, Qi, T2, W1, and W4); for these subjects, intraperson divergences were <3%, and the sequences were genotypically identical. For one person, Ei, the sequence from the blood sample was 4.6% divergent from that from the throat-gargle sample, and their genotype assignments were different: genotype B for the blood sequence and genotype B/C [12] for the throat-gargle sequence (data not shown).

**Differences in K1/V1 consensus sequences.** For 24 people, K1/V1 DNA could be amplified from at least 2 samples. K1/V1 sequences were identical between at least 2 samples from 8 people (E6, H2, Ki, K1, P1, X1, Zi and Z2); for 1 person, Zi, sequences in 3 samples (mouth rinse, palatal exfoliate, and blood) were identical. Nonidentical sequences were found in samples from 16 people, with intraperson divergences ranging from 0.6% (between the mouth-rinse and throat-gargle samples of E4) to 28.9% (between the palatal-exfoliate and throat-gargle samples of Y1). A dendrogram displaying the variation in consensus K1/V1 sequences among the samples is shown in figure 3. The sequences primarily cluster with those reported from African patients with KS [3, 12] and have been deposited in GenBank (accession nos. Y219483–AY219535).

Seven of the 16 people with nonidentical intraperson K1/V1 sequences yielded samples that carried sequences belonging to 2 genotypes. These were the palatal-exfoliate and blood samples from Fi (A2 and B, respectively), mouth-rinse and throat-gargle samples from T3 (B and A2, respectively); mouth-rinse and throat-gargle samples from W2 (B and A2, respectively); throat-gargle and palatal-exfoliate samples from Y1 (A2 and B, respectively); and mouth-rinse and palatal-exfoliate samples from Y2 (A2 and A5, respectively). For Ki, the identical sequences from her blood and mouth-rinse samples (genotype A5) were different than those from her palatal-exfoliate sample (genotype A2), whereas for P1, the identical sequences from her mouth-rinse and throat-gargle samples (genotype A5) were different than those from her palatal-exfoliate sample (genotype B). For 1 other person, I2, K1/V1 sequences belonged to 3 genotypes (mouth rinse, A1; throat gargle, B; and palatal exfoliate, C2). For 3 people whose samples were found to carry nonidentical sequences of the same genotype (all genotype B), intraperson/

Patient	Age/sex	Anti HHV-8 serostatus	Anti HIV serostatus	Mouth rinse			Gargle			Palate			Blood		
				IRD	KS330	K1/V1	IRD	KS330	K1/V1	IRD	KS330	K1/V1	IRD	KS330	K1/V1
B5	7 y/M	+	-	-	+	+	-	-	-	-	+	+	-	-	-
Ci	8 y/M	+	+	+	+	+	+	+	+	-	+	-	-	-	-
Ei	31 y/F	+	+	-	-	+	-	+	+	-	-	-	-	+	+
E4	9 y/F	+	-	-	+	+	-	+	+	-	-	-	-	-	-
E6	6 y/F	+	-	-	+	+	-	+	+	-	-	-	-	-	-
<b>Fi</b>	2 y/M	+	+	+	-	-	-	+	+	-	+	+	-	-	+
<b>G2</b>	23 y/M	+	-	+	+	+	+	+	+	-	-	-	-	-	+
H2	12 y/M	+	-	-	+	+	-	-	+	-	-	+	-	-	-
<b>I2</b>	11 y/F	-	-	-	-	+	-	-	+	-	-	+	-	-	-
<b>Ki</b>	30 y/F	+	+	+	+	+	-	-	-	-	+	+	-	+	+
K1	12 y/M	-	-	-	+	+	-	-	-	-	+	+	-	-	-
<b>P1</b>	28 y/F	+	+	-	+	+	-	-	+	-	-	+	-	-	-
Qi	24 y/F	+	+	-	+	+	-	-	-	-	-	+	+	+	+
<b>T2</b>	11 y/M	+	-	+	+	+	+	+	+	-	+	-	-	-	-
T3	9 y/M	+	-	+	+	+	-	-	+	-	-	-	-	-	-
W1	36 y/M	+	+	-	+	+	-	+	+	-	-	-	-	-	-
<b>W2</b>	20 y/M	+	-	+	+	+	-	+	+	-	-	-	-	-	-
W4	13 y/M	+	-	+	+	+	+	+	+	-	+	-	-	-	-
<b>X1</b>	44 y/M	+	+	+	+	+	+	+	+	-	+	-	-	-	-
<b>Y1</b>	32 y/M	+	-	-	-	+	-	-	-	-	-	+	-	-	-
Y1	38 y/F	+	-	-	-	-	-	-	+	-	-	-	-	-	-
Y2	8 y/F	-	-	-	-	+	-	-	-	-	-	+	-	-	-
Zi	2 y/M	+	+	-	+	+	nd	nd	nd	-	-	+	-	-	+
Z2	22 y/F	+	-	-	+	+	-	-	-	-	+	+	-	-	-

**Figure 1.** Patient demographic and virological characteristics. Anti-human herpesvirus (HHV)-8 serostatus was determined by anti-HHV-8 IgG immunofluorescence assay [3]. Anti-human immunodeficiency virus (HIV) status was determined by anti-HIV-8 particle assay [3]. ND, not done. Samples from individuals whose K1/V1 sequences were further studied (summarized in figures 4, 5, and 6, and 7) are boxed. Sites affected by KS in patients with KS: Ci, abdomen and limbs; Ei, legs and palate; Fi, foot; Ki, leg; Qi, foot; Yi, arm; Zi, neck.

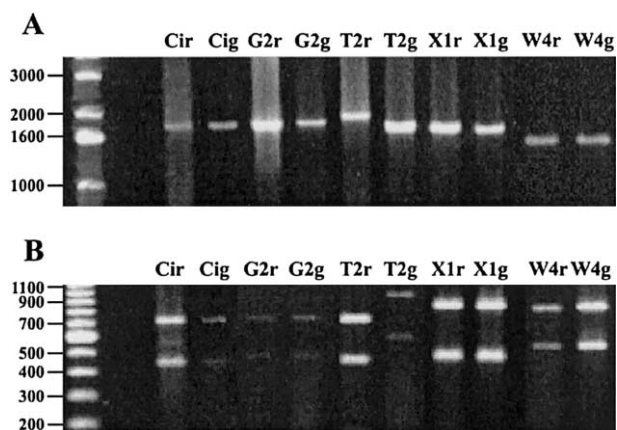

**Figure 2.** Gel-electrophoretic length polymorphisms of internal repeat domain amplicons without (A) and with (B) restriction by *Mbol* and *BanII*. DNA marker bands (100 bp) are shown on the left. Letters after patient identifiers: g, gargle; r, rinse.

intersample sequences were >5% divergent: Cir/Cig (5.4%), T2g/T2r (5.4%), and Yir/Yip (5.9%).

**Clonal analysis of intraperson/intersample K1/V1 sequence differences.** High-fidelity PCR of sample extracts from 9 people (Fi, G2, I2, Ki, P1, T2, W2, X1, and Yi) yielded K1/V1 DNA. Clones were generated from which differences in nucleotide sequence could be analyzed by the combined DGGE-sequencing approach. Figure 4 is a composite of representative DGGE gel pictures showing migration distances achieved by amplicons generated from clonal inserts; each gel accommodates, for a given person, K1/V1 DNA derived from up to 15 clones/sample. All PCR products that yielded minority banding positions and some products representing the majority were sequenced (denoted by dots in figure 4; numerals correspond to lane positions in the gel illustrated). Figure 5 is a nonrooted dendrogram depicting the extent of intersample K1/V1 nucleotide sequence diversity. Sequences derived from the PCR clones have been deposited in GenBank (accession nos. AY220915–AY2209801). Figure 6 is an alignment of a stretch of amino acid sequences predicted from the nucleotide sequences studied.

DGGE and nucleotide sequencing analyses confirmed findings from direct K1/V1 PCR sequencing that >1 genotype was carried by Fi, I2, Ki, P1, W2, and X1. Analysis of clones from minority sequences permitted intrasample K1/V1 variability to be further characterized from individual samples. For the mouth-rinse sample from I2, the existence of a group of minority sequences comprising I2r 5 and 8 became evident, with both being 6.4% divergent from the majority sequence I2r4; all 3 sequences belonged to genotype B. In addition, a small population of closely related genotype A1 sequences (I2r 1, 3, 13, and 14) was identifiable. For Ki and P1, the presence of minority sequences belonging to genotypes not evident after direct sequencing could be revealed. In the mouth-rinse sample

from Ki, the genotype of the minority sequences Kir 8/10 and 9 (B) was different than that of the majority sequence Kir 4 (A5). Similarly, from her palatal-exfoliate sample, the genotype of a set of related minority sequences—Kip 17, 23, and 27 (A2)—and of a unique sequence, Kip 29 (B), were different than that of the dominant sequence, Kip 19 (A5). The 2 genotype B mouth-rinse nucleotide sequences, Kir 8/10 and 9, were 5.0% and 5.4% divergent, respectively, from Kip 29 (figure 5). There were, thus, a total of 4 different groups of sequences that originated from Ki's mouth-rinse and palatal-exfoliate samples. From the palatal-exfoliate sample of P1, an additional genotype (A5) could be assigned to a population of clones bearing the P1p 16/24/29 sequence, contrasting with the genotype (B) assigned to the majority sequence (P1p 17).

For 2 people, X1 and Yi, direct sequencing of K1/V1 from their samples generated sequences assignable as genotype B, but, for each person, clonal analysis revealed carriage of minority sequences belonging to another genotype. For the throat-gargle sample from X1, this was A5 (assigned to X1g28); and for the palatal-exfoliate sample from Yi, it was A2 (assigned to sequences typified by Yip 17, 20, 21, and 22). X1's mouth-rinse sample carried the following minority sequences: X1r6; and a closely related group of sequences, X1r 3/11, 9, and 13, which were all 5.0% divergent from X1r6.

For T2, although direct sequencing yielded genotype B sequences from both his mouth-rinse and throat-gargle samples, analysis of the clones generated revealed that each sample carried its own distinct set of sequences: T2r 9 and 15 from the mouth-rinse sample, and T2g16/18/24, 20, and 22 from the throat-gargle sample; the latter sequences were 5.9%, 6.4%, and 6.4% divergent, respectively, from T2r 9. The intra- and intersample distribution of genotypes and subgenotypically distinct sequences recovered from the 9 people described here is summarized in figure 7.

## DISCUSSION

Multiple HHV-8 infection rarely has been considered. Putative recombinant HHV-8 genomes have been characterized [12], assuming dual infection in at least a single host cell. Most studies of humans who have developed KS [11, 14–16] or multiple HHV-8-associated lesions [17] have not shown intraperson variation in HHV-8 subgenomic sequences amplified by PCR from blood and lesional tissues.

Gao et al. [14] reported that, of 27 KS lesional samples studied, 2 were dually infected. Otherwise, there are no reports of mixed HHV-8 infection. This paucity may be due to a combination of factors. First, samples from homosexual men favor hosts who are exposed to HHV-8 later in life, rather than early in childhood, and favor HHV-8 strains transmitted via sexual routes, rather than those transmitted nonsexually within the

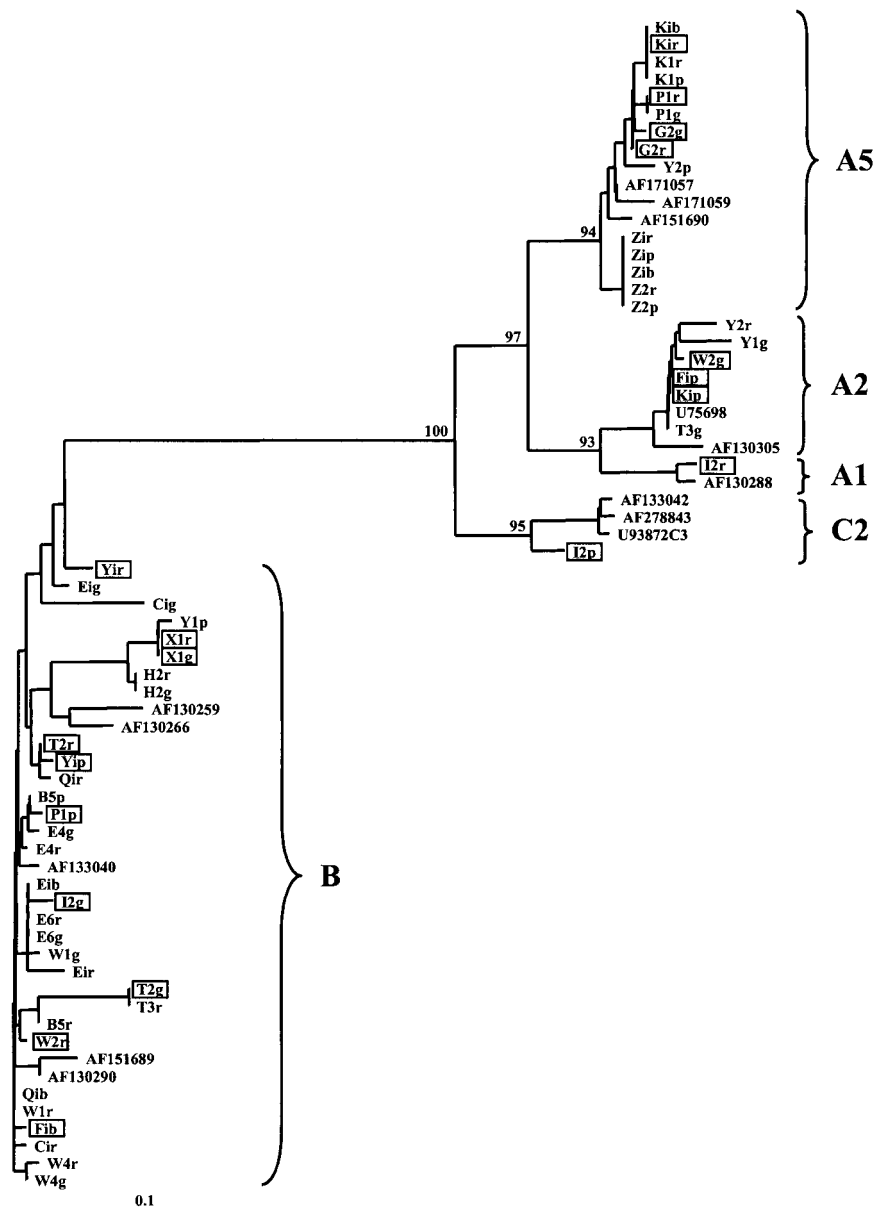
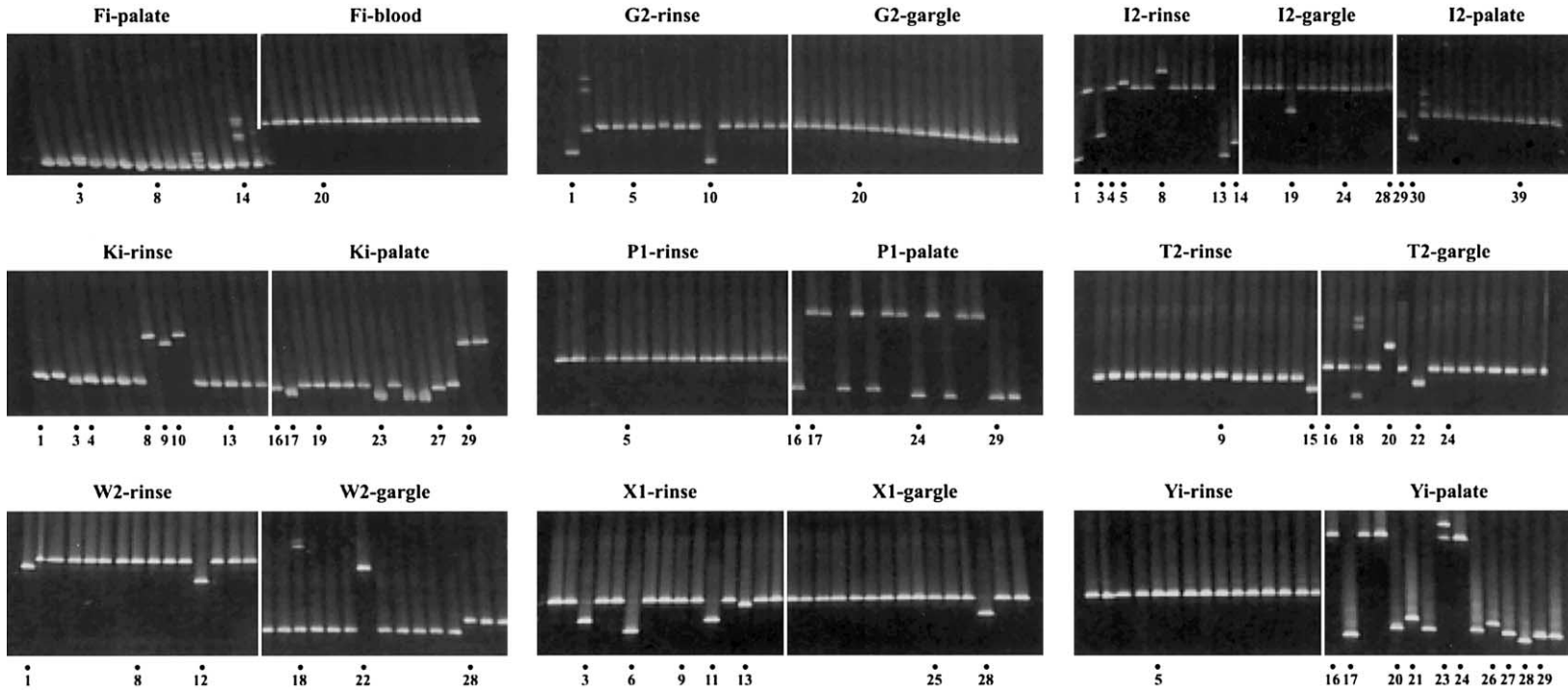

**Figure 3.** Predicted phylogenetic distribution of consensus K1/V1 sequences derived from blood and oral samples from 24 people. Samples from individuals whose K1/V1 sequences were further studied (summarized in figures 4, 5, 6, and 7) are boxed. Bootstrapping for 1000 replicates is noted as a percentage at major branch points. Horizontal line at bottom left represents 10% nt substitution for that horizontal branch length. Letters after patient identifiers: b, blood; g, gargle; p, palate; r, rinse.

household or community. Second, previous studies have been largely confined to patients with KS or patients who are at risk of developing KS. When sequence polymorphism of subgenomic HHV-8 DNA in the blood is sought from such people, the tendency is for none to be found, particularly when consensus sequencing is applied, because the high HHV-8 genome load [7] favors the generation of sequences reflecting the dominant variants. When sequence polymorphism in KS lesional tissues is sought, it is also likely that none will be found, not because of the high viral genome load [18, 19] but because KS

is largely a clonal tumor [20, 21]. Third, in previous studies examining for HHV-8 genomic polymorphisms, the PCR products were directly amplified from the samples [11, 12, 14–17]; in doing so, the existence of minor virus populations would have been revealed only if they constituted a relatively large fraction (>20%) of the entire population [22]. When consensus sequencing protocols are applied, the sequence information obtained will not differentiate minority sequences from the sequence of the dominant variant.

The present study focuses on whether intrahost HHV-8 sub-



**Figure 4.** Composite of 9 denaturing gradient gel electrophoresis gel photographs. Each gel accommodates, for a given individual, K1/V1 DNA amplified from up to 15 K1/V1 clones generated per sample. Dots at bottom indicate polymerase chain reaction products that underwent sequencing; numerals indicate lane positions in the gel.

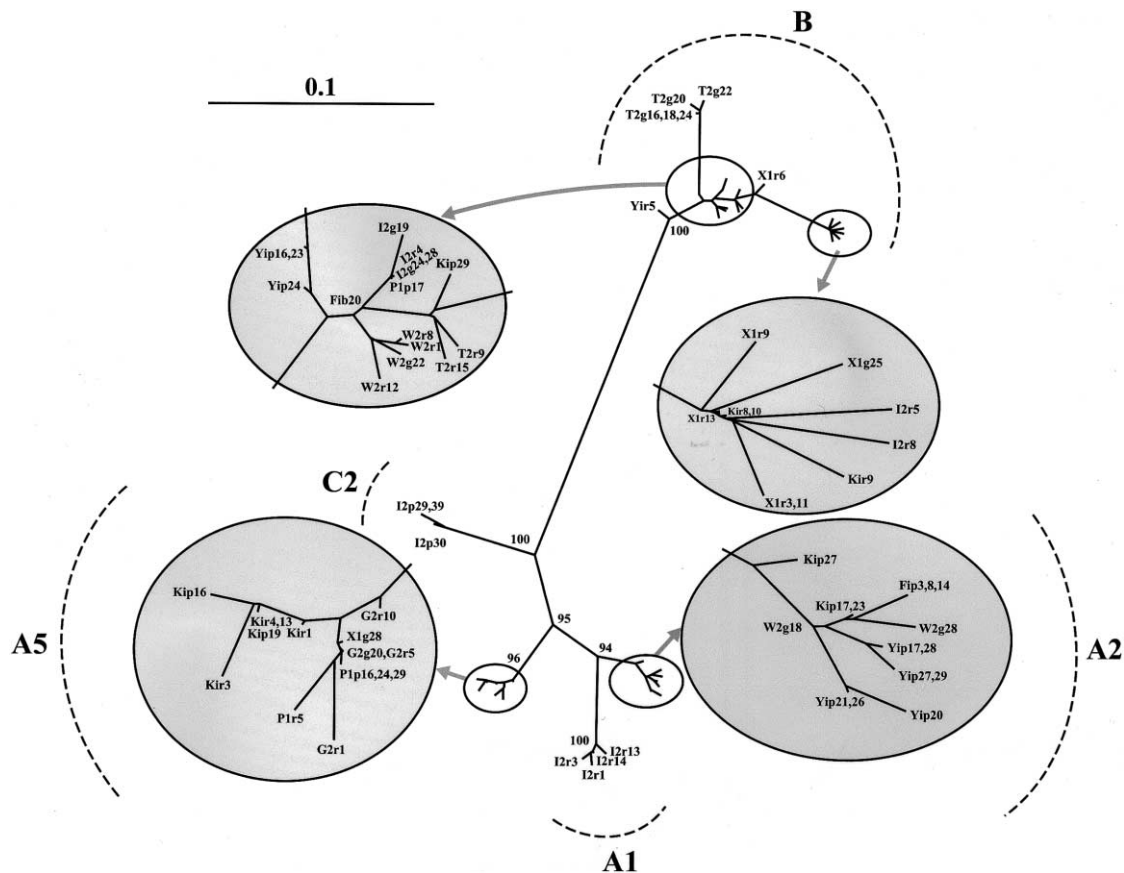

**Figure 5.** Radical unrooted phylogenetic dendrogram of sequences amplified from polymerase chain reaction clones with K1/V1 inserts. Sequences are derived from blood and oral samples from 9 people. Horizontal line at top left represents 10% nt substitution for that horizontal branch length. Letters after patient identifiers: b, blood; g, gargle; p, palate; r, rinse.

genomic sequence polymorphism exists among and within oral and blood samples of Malawian individuals with and without KS and the extent of such polymorphism. This group of HHV-8–infected people is a subset of a population whose characteristics and possible routes of HHV-8 acquisition have been described elsewhere [3, 4]. Although our previous reports focused on interperson HHV-8 subgenomic sequence variation, the present study focuses on intraperson variation. Accordingly, sequence polymorphism data from 2 other oral components, in addition to the mouth-rinse sample (which principally permits characterization of HHV-8 carried in the nonkeratinized oral compartment), are presented here: the throat-gargle sample, to reflect HHV-8 carried predominantly in the pharyngeal compartment, and the palatal-exfoliate sample, which has consistently been shown in HIV-coinfected people to be the most common site of development for KS [23, 24], suggesting that HHV-8 might be particularly tropic for this anatomical site. These 2 other oral samples were collected at the same time as the blood and mouth-rinse samples.

The present study is limited by several factors. The first is the variability in PCR amplification yields from the various samples.

This variability depends on the type of sample examined. That mouth-rinse and throat-gargle samples yielded higher amplification rates than did blood and palatal-exfoliate samples probably reflects active HHV-8 replication in the oral epithelium other than the hard palate, the high load of shedding into the oral cavity [25], and the possible lower replicative activity of the virus systemically and in the palatal mucosa. Blood samples yielded HHV-8 subgenomic amplicons in a substantial proportion of patients with KS but not at all in those without KS. This result confirms our previous data [3] showing that, in HHV-8–infected African people not affected by KS, the virus is not shed into the circulation to a significant extent and that the principal site of viral shedding is the mouth. Variability in amplification rates also depended on the region within the HHV-8 genome to be amplified. Higher yields from KS330 and K1/V1, rather than from the IRD, are due to the much longer amplicon that needs to be generated to permit subsequent analyses.

A further limiting factor was the difference in the degree to which the 3 approaches permitted evaluation of subgenomic HHV-8 sequence differences. Analysis of length polymorphisms in IRD amplicons was the least efficient approach to discrimi-





Person	Sample	No. of genotypes		No. of sequences with $\geq 5\%$ divergence	
		Per sample	Per person	Per sample	Per person
Fi	Palate	1(B)	}2	1	}2
	Blood	1(A2)		1	
G2	Rinse	1(A5)	}1	1	}1
	Gargle	1(A5)		1	
I2	Rinse	2(A1, B)	}3	3	}4
	Gargle	1(B)		1	
	Palate	1(C2)		1	
Ki	Rinse	2(A5, B)	}3	2	}4
	Palate	3(A2, A5, B)		3	
P1	Rinse	1(A5)	}2	1	}2
	Palate	2(A5, B)		2	
T2	Rinse	1(B)	}1	1	}2
	Gargle	1(B)		1	
W2	Rinse	1(B)	}2	1	}2
	Gargle	2(A2, B)		2	
X1	Rinse	1(B)	}2	2	}3
	Gargle	2(A5, B)		2	
Yi	Rinse	1(B)	}2	1	}3
	Palate	2(A2, B)		2	

**Figure 7.** Intrasample and intraperson distribution of genotypically and subgenotypically distinct K1/V1 sequences.

intersample sequence polymorphism, high-fidelity PCR was applied to sample extracts. High-fidelity PCR was, however, relatively inefficient in generating the amplicons. This explains why, of extracts from the 24 people from whom intersample K1/V1 sequence differences could be evaluated by direct sequencing, K1/V1 amplicons were generated from sample extracts from only 9 people.

We provide evidence of multiple HHV-8 infection in a substantial proportion (60%) of the 24 Malawian people studied. The evidence was derived from intraperson genotype and subgenotype sequence differences found among and within samples. Genotypic differences are clear between the blood and oral samples from 3 patients with KS: for Ei, from whom KS330 sequences were genotypically distinct; and for Fi and Ki, from whom K1/V1 sequences were genotypically distinct. For 4 other patients with KS, sequence variations in KS330 or K1/V1, or both, in blood and oral samples were either absent (for Zi) or not different enough to permit genotypic or subgenotypic discrimination (for Ci, Ei, and Qi). Because HHV-8 genomic sequences carried in blood and oral samples from these 7 patients with KS could be either genotypically identical or different, conclusions cannot be drawn about the selective tropism of HHV-8 strains. Current evidence from other studies suggests that HHV-8 exhibits broad tropism [25–27].

Evidence for the oral carriage of multiple strains of HHV-8 can be found for 11 people. Intersample genotype differences are clearly discernible: for T2, from IRD length polymorphism findings; and for I2, Ki, P1, T3, W1, W2, Y1, and Y2, from direct sequencing data on KS330 or K1/V1, or both. Of particular interest are the 3 samples from I2, each of which yielded

K1/V1 sequences belonging to a different genotype. Analyses of data from PCR clones revealed genotypic differences in individual samples from I2 (mouth rinse), Ki (mouth rinse and palatal exfoliate), P1 (palatal exfoliate), W2 (throat gargle), X1 (throat gargle), and Yi (palatal exfoliate). Sequences belonging to 3 different genotypes were found in the palatal-exfoliate sample from Ki.

For 2 people whose oral samples yielded genotypically distinct HHV-8 variants, clonal analyses further revealed subgenotypic differences: for T2, between mouth-rinse and throat-gargle samples; and for I2, in the mouth-rinse sample. For 2 other people whose oral samples yielded genotypically identical HHV-8 variants, analysis of PCR clones also revealed subgenotypic differences: for Yi, between throat-gargle and palatal-exfoliate samples; and for X1, in the mouth-rinse sample. Whether, for these 4 people, the distinct but closely related variants originated from founder strains that underwent genetic drift after infection or were introduced at different exposure time points cannot yet be determined.

We found HHV-8 DNA in oral samples from 3 anti-HHV-8-seronegative people (I2, K1, and Y2). All 3 subjects were children and were anti-HIV-1 seronegative (figure 1). It is likely that the samples were obtained at the early phase of primary HHV-8 infection (before anti-HHV-8 is mounted to a detectable extent), but follow-up testing of the anti-HHV-8 serostatus would need to be done to monitor for HHV-8 seroconversion. That the K1/V1 amplicons obtained from these children were not due to PCR-related contamination is suggested by the uniqueness of K1/V1 sequences derived from I2's mouth-rinse, throat-gargle, and palatal-exfoliate samples, and Y2's mouth-rinse and palatal-exfoliate samples (figure 3). The sequence derived from K1's mouth-rinse and palatal-exfoliate samples was identical to that from the blood and mouth-rinse samples from Ki, his mother, a result that is consistent with the dynamics of intrafamilial transmission [3].

Although there is constant mixing of cellular components and secreted fluids from various anatomical compartments in the mouth and the oropharynx, the mouth-rinse, throat-gargle, and palatal-exfoliate samples may be considered to hold cells and fluids that originate from different compartments. Our discovery that each of the compartments sampled can harbor distinct HHV-8 strains suggests that different strains may preferentially persist and replicate in different cell types. Why this is so remains unclear. The roles played by sequential exposure to HHV-8, differences in inoculation routes, inter- and intra-species viral interference, difference in anatomical site susceptibility to dissemination of HHV-8 from other body sites, systemic and local immune responses, and coexisting oral diseases require further investigation.

Our study was confined to examination of HHV-8 carried in the blood and the mouth. Sampling of other body sites might

reveal yet more evidence of multiple HHV-8 carriage. Multiple oral infection by other herpesviruses (e.g., cytomegalovirus [28] and Epstein-Barr virus [29]) has been reported elsewhere, mainly in people who have been immunosuppressed. Our findings show that apparently healthy people in regions where HHV-8 is hyperendemic can be multiply infected by HHV-8. The coexistence in a given host of >1 HHV-8 strain, particularly if the strains are genotypically different, potentially confounds molecular epidemiologic analyses of HHV-8 transmission. Strains that persist in the host as minority variants will not be revealed if appropriate methods are not applied, and such variants will be missed in the course of tracking the spread of HHV-8.

It would also be important to determine whether multiple HHV-8 carriage reflects simultaneous coinfection by >1 HHV-8 strain, reactivation of latent strains, or superinfection. If it reflects superinfection, then such transmissions may not be prevented by vaccination. Nonetheless, although the immune system might not prevent superinfecting virus from initiating replication in the host, it might, after vaccination, prevent the further spread of the initial infecting strain and of the subsequent superinfecting strains. In view of the relentless march of HIV/AIDS in Africa, where HHV-8 is also hyperendemic, initiatives to develop vaccines against HHV-8 would be beneficial.

## Acknowledgments

We thank I. Mbebuwa for nursing and interpretation assistance, A. Waugh and R. Fudzulani for assistance with sample processing, S. J. Gao for helpful technical advice, J. Hall for invaluable help with the illustrations, and P. P. Mortimer for critical reading of the manuscript.

## References

1. Ablashi DV, Chatlynne LG, Whitman JE Jr, Cesarman E. Spectrum of Kaposi's sarcoma-associated herpesvirus, or human herpesvirus 8, diseases. *Clin Microbiol Rev* **2002**; 15:439–64.
2. Plancoulaine S, Abel L, van Beveren M, et al. Human herpesvirus 8 transmission from mother to child and between siblings in an endemic population. *Lancet* **2000**; 356:1062–5.
3. Cook RD, Hodgson TA, Waugh AC, et al. Mixed patterns of transmission of human herpesvirus-8 (Kaposi's sarcoma-associated herpesvirus) in Malawian families. *J Gen Virol* **2002**; 83:1613–9.
4. Cook RD, Hodgson TA, Molyneux EM, Borgstein E, Porter SR, Teo CG. Tracking familial transmission of Kaposi's sarcoma-associated herpesvirus using restriction fragment length polymorphism analysis of latent nuclear antigen. *J Virol Methods* **2002**; 105:297–303.
5. Corey L, Brodie S, Huang ML, Koelle DM, Wald A. HHV-8 infection: a model for reactivation and transmission. *Rev Med Virol* **2002**; 12: 47–63.
6. Andreoni M, Sarmati L, Nicastrì E, et al. Primary human herpesvirus 8 infection in immunocompetent children. *JAMA* **2002**; 287: 1295–300.
7. Tedeschi R, Enbom M, Bidoli E, Linde A, De Paoli P, Dillner J. Viral load of human herpesvirus 8 in peripheral blood of human immu-

8. Leao JC, Kumar N, McLean KA, et al. Effect of human immunodeficiency virus-1 protease inhibitors on the clearance of human herpesvirus 8 from blood of human immunodeficiency virus-1-infected patients. *J Med Virol* **2000**; 62:416–20.
9. Zhang YJ, Deng JH, Rabkin C, Gao SJ. Hot-spot variations of Kaposi's sarcoma-associated herpesvirus latent nuclear antigen and application in genotyping by PCR-RFLP. *J Gen Virol* **2000**; 81:2049–58.
10. Di Alberti L, Ngui SL, Porter SR, et al. Presence of human herpesvirus 8 variants in the oral tissues of human immunodeficiency virus-infected persons. *J Infect Dis* **1997**; 175:703–7.
11. Zong J, Ciufu DM, Viscidi R, et al. Genotypic analysis at multiple loci across Kaposi's sarcoma herpesvirus (KSHV) DNA molecules: clustering patterns, novel variants and chimerism. *J Clin Virol* **2002**; 23: 119–48.
12. Poole LJ, Zong JC, Ciufu DM, et al. Comparison of genetic variability at multiple loci across the genomes of the major subtypes of Kaposi's sarcoma-associated herpesvirus reveals evidence for recombination and for two distinct types of open reading frame K15 alleles at the right-hand end. *J Virol* **1999**; 73:6646–60.
13. Harris KA, Teo CG. Diversity of hepatitis C virus quasispecies evaluated by denaturing gradient gel electrophoresis. *Clin Diagn Lab Immunol* **2001**; 8:62–73.
14. Gao SJ, Zhang YJ, Deng JH, Rabkin CS, Flore O, Jenson HB. Molecular polymorphism of Kaposi's sarcoma-associated herpesvirus (human herpesvirus 8) latent nuclear antigen: evidence for a large repertoire of viral genotypes and dual infection with different viral genotypes. *J Infect Dis* **1999**; 180:1466–76.
15. Meng YX, Sata T, Stamey FR, et al. Molecular characterization of strains of human herpesvirus 8 from Japan, Argentina and Kuwait. *J Gen Virol* **2001**; 82:499–506.
16. Stebbing J, Wilder N, Ariad S, Abu-Shakra M. Lack of intra-patient strain variability during infection with Kaposi's sarcoma-associated herpesvirus. *Am J Hematol* **2001**; 68:133–4.
17. Codish S, Abu-Shakra M, Ariad S, et al. Manifestations of three HHV-8-related diseases in an HIV-negative patient: immunoblastic variant multicentric Castleman's disease, primary effusion lymphoma, and Kaposi's sarcoma. *Am J Hematol* **2000**; 65:310–4.
18. Lallemand F, Desire N, Rozenbaum W, Nicolas JC, Marechal V. Quantitative analysis of human herpesvirus 8 viral load using a real-time PCR assay. *J Clin Microbiol* **2000**; 38:1404–8.
19. Bezold G, Messer G, Peter R, Flaig M, Sander C. Quantitation of human herpes virus 8 DNA in paraffin-embedded biopsies of HIV-associated and classical Kaposi's sarcoma by PCR. *J Cutan Pathol* **2001**; 28:127–30.
20. Rabkin CS, Janz S, Lash A, et al. Monoclonal origin of multicentric Kaposi's sarcoma lesions. *N Engl J Med* **1997**; 336:988–93.
21. Judde JG, Lacoste V, Briere J, et al. Monoclonality or oligoclonality of human herpesvirus 8 terminal repeat sequences in Kaposi's sarcoma and other diseases. *J Natl Cancer Inst* **2000**; 92:729–36.
22. Ngui SL, Teo CG. Hepatitis B virus genomic heterogeneity: variation between quasispecies may confound molecular epidemiological analyses of transmission incidents. *J Viral Hepat* **1997**; 4:309–15.
23. Flaitz CM, Jin YT, Hicks MJ, Nichols CM, Wang YW, Su JJ. Kaposi's sarcoma-associated herpesvirus-like DNA sequences (KSHV/HHV-8) in oral AIDS-Kaposi's sarcoma: a PCR and clinicopathologic study. *Oral Surg Oral Med Oral Pathol Oral Radiol Endod* **1997**; 83:259–64.
24. Gorsky M, Epstein JB. A case series of acquired immunodeficiency syndrome patients with initial neoplastic diagnoses of intraoral Kaposi's sarcoma. *Oral Surg Oral Med Oral Pathol Oral Radiol Endod* **2000**; 90:612–7.
25. Pauk J, Huang ML, Brodie SJ, et al. Mucosal shedding of human herpesvirus 8 in men. *N Engl J Med* **2000**; 343:1369–77.
26. Dupin N, Fisher C, Kellam P, et al. Distribution of human herpesvirus-8

- latently infected cells in Kaposi's sarcoma, multicentric Castleman's disease, and primary effusion lymphoma. *Proc Natl Acad Sci USA* **1999**; 96:4546–51.
27. Blackbourn DJ, Lennette E, Klencke B, et al. The restricted cellular host range of human herpesvirus 8. *AIDS* **2000**; 14:1123–33.
28. Bar M, Shannon-Lowe C, Geballe AP. Differentiation of human cytomegalovirus genotypes in immunocompromised patients on the basis of UL4 gene polymorphisms. *J Infect Dis* **2001**; 183:218–25.
29. Triantos D, Boulter AW, Leao JC, et al. Diversity of naturally occurring Epstein-Barr virus revealed by nucleotide sequence polymorphism in hypervariable domains in the BamHI K and N subgenomic regions. *J Gen Virol* **1998**; 79:2809–17.