

Context for the ESA ExoMars Rover: the Panoramic Camera (PanCam) Instrument

Andrew D. Griffiths¹, Andrew J. Coates¹, Ralf Jaumann², Harald Michaelis², Gerhard Paar³, David Barnes⁴, Jean-Luc Josset⁵ and the PanCam team*

¹ UCL, Mullard Space Science Laboratory, Holmbury St. Mary, Dorking, Surrey, RH5 6NT, UK

² Deutsches Zentrum für Luft- und Raumfahrt e.V. (DLR), Institut für Planetenforschung, Rutherfordstr. 2, D-12489 Berlin, Germany

³ Institute for Space Exploration, Jaquet-Droz 1, Case Postale CH-2007, Neuchâtel, Switzerland

⁴ Department of Computer Science, University of Wales, Penglais, Aberystwyth Ceredigion, SY23 3DB, UK

⁵ Institute of Digital Image Processing, Joanneum Research, Wastiangasse 6, A-8010 Graz, Austria

Abstract: The recently approved ExoMars rover is the first element of the ESA Aurora programme and is slated deliver the Pasteur exobiology payload to Mars by 2013. The 0.7 kg Panoramic Camera will provide multispectral stereo images with 65° field-of-view (1.1 mrad/pixel) and high resolution (85 μ rad/pixel) monoscopic “zoom” images with 5° field-of-view. The stereo Wide Angle Cameras (WAC) are based on Beagle 2 Stereo Camera System heritage (Griffiths, *et al*, 2005). The Panoramic Camera instrument is designed to fulfil the digital terrain mapping requirements of the mission as well as providing multispectral geological imaging, colour and stereo panoramic images and water vapour abundance and dust optical depth measurements. It can also be used for high resolution imaging of inaccessible locations on crater walls and to observe retrieved subsurface samples before ingestion into the rest of the Pasteur payload.

Keywords: Mars, ExoMars Rover, Pasteur Payload, Imaging: Stereoscopic, Imaging, Multispectral, DEM

* Andrew John Coates (Team Coordinator), Ralf Jaumann (Deputy T.C.: HRC), Jean-Luc Josset (Deputy T.C.: WAC), Andrew Donald Griffiths, Jürgen Oberst, Jörg Alibert, Dave Barnes, Jean Pierre Bibring, Ian Crawford, Alex Ellery, Vittorio Formisano, Stephan van Gasselt, Rob Gowen, Ernst Hauber, Harald Hoffmann, Beda Anton Hofmann, Yves Langevin, Ron Li, Wojciech Markiewicz, Philippe Masson, Harald Michaelis, Stefano Mottola, Gerhard Paar, Derek Pullan, Peter Reuffer, Tilman Spohn, Nick Thomas, Roland Trautner

Introduction

The Panoramic Camera (PanCam) imaging experiment is designed to obtain high-resolution colour and wide angle multispectral stereoscopic panoramic images from the mast of the ExoMars rover (as part of the Pasteur payload). Figure 1 shows an artists impression of ExoMars on the Martian surface.

Launch on a Soyuz Fregat would occur in June 2011 or 2013, with a landing on Mars two years later (to avoid the perihelion dust storm season).

The objective of the ExoMars mission (Vago, 2005) is to find evidence of extant or extinct life in the Martian regolith, using a drill system capable of reaching depths of up to 2 m. To achieve this objective it is vitally important to know where to drill. To aid in selecting the correct sample site the baseline Pasteur payload consists of a set of remote sensing (including PanCam, an infra-red spectrometer and a ground penetrating radar) and contact instruments (the close-up imager, Mössbauer and Raman/LIBS spectrometers). Once a sample has been acquired it is inserted into an internal analytical suite (i.e. Urey Mars organics detector, GCMS, X-ray diffractometer, microscope and life marker chip) designed to detect a variety of organic compounds.

Therefore, the main scientific objectives to be addressed by the PanCam experiment are:

1. To locate the landing site or most recent rover position and support the ExoMars rover traverse planning.
2. To geologically investigate and map the rover sites.
3. To study the properties of the atmosphere and of variable phenomena.



Fig. 1. Artists impression of the ExoMars rover (courtesy ESA)

4. And last, but not least, to support the scientific measurements of other Pasteur instruments, i.e. by identifying the most promising locations for exobiological studies.

The camera system will consist of two identical wide-angle cameras (WAC), which are arranged on a common pan-tilt mechanism, with a fixed stereo base length of 50 cm. An additional high-resolution camera (HRC), mounted between the WAC, allows a magnification of selected targets by a factor of 13 w.r.t. the wide-angle optics.

The camera head assembly will be mounted on top of the rover mast (~1.8 m above the surrounding terrain), which can pan 360° about the vertical axis to obtain a full (stereo, colour or multispectral) panorama and tilt by $\pm 90^\circ$ in elevation w.r.t. to the horizon. In this way, nearly every possible target can be pointed at by the camera system, in addition to monitoring of the rover's drilling and coring activities.

The PanCam incorporates heritage from the Stereo Camera System flown on the Beagle 2 Mars lander and from the stereoscopic Panorama Camera being presently developed for the NetLander surface modules (Jaumann et al., 2000). The baseline PanCam configuration is shown in figure 2.

The Wide Angle Stereo Cameras (WAC)

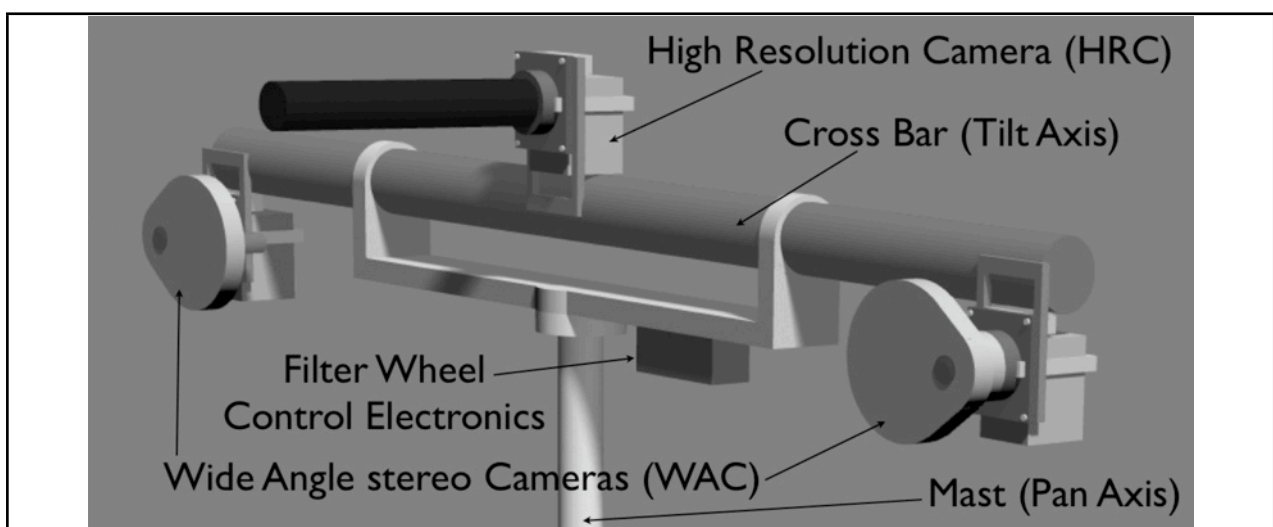

Fig. 2. The baseline configuration of the Panoramic camera system.

The wide angle stereo cameras consist of two identical “eyes” each composed of a CCD camera module with 65° field of view (FOV) lens and a filter wheel module containing 12 narrow bandwidth interference coated filters. The large WAC FOV is driven by the requirement to minimise the panoramic image data volume that must be returned to Earth (via the Mars Reconnaissance Orbiter for the baseline mission). MSSL will provide the filter wheel modules (along with WAC science lead and PanCam project management), while the Institute for Space Exploration (in collaboration with Space-X of Neuchâtel) will provide the camera modules.

The WAC camera heads will be equipped with a CCD sensor producing grey scale images of 1024 x 1024 pixels, quantified in 10 bits, in the spectral range 400 to 1000 nm. These detectors have optics with a focal length of 10 mm, yielding intrinsic resolutions of the cameras is 1.1 mrad. The WAC eyes are expected to weigh 200 g (each) and consume 1.5 W of power.

The High Resolution Camera

The HRC is provided by DLR/IPF in Berlin and will utilise an active pixel sensor (APS) with 1024 x 1024 pixels. The HRC optics have a focal length of ~130 mm, yielding a FOV of 5°. The spatial resolution of this camera (IFOV) is 13 times that of the WACs at about 85 µrad per pixel. The HRC is expected to weigh 300 g and consume 0.9 W of power.

The colour capability of the HRC is provided by “stripe” interference filters, each directly bonded over part of the active area of the APS. Thus, with the limited number of colours required, the additional moving parts of a filter wheel mechanism are not necessary – but the additional complication of having to move the camera head (to mosaic each colour swath across the detector FOV) is introduced.

PanCam Science Goals

Given the prevailing Martian environment, particularly the extreme dryness and oxidising surface conditions, there is no expectation of finding evidence of macroscopic life on the surface of Mars today (e.g. ESA Exobiology Team, 1999). Even the remains of microscopic life from the putative warmer, wetter period of more than three billion years ago would need to be buried beneath the oxidising layer to be recognisable as such now. Clearly therefore PanCam is not a life detection instrument but instead forms the first tier of the Pasteur payloads multi-level strategy for detecting evidence of biological processes on Mars (Vago, 2005).

The first stage of this strategy is a thorough geological mapping of the surface (soil, rocks and outcrops) within sight of the rover using PanCam and the IR spectrometer. Evidence of water bearing minerals, water altered rocks or even water deposited sediments would then be followed up by the next tier of contact instruments to enable a decision on whether or not to acquire samples for further analysis. Additionally, the ground penetrating radar will be used to map the near surface stratigraphy and look for evidence of ground water or ice to inform the decision on where to drill.

Therefore, the major geo-scientific objectives of the PanCam images are the identification of surface features like outcrops, ridges and troughs, and the characterisation of different rock and surface units based on their morphology, distribution, and spectral and physical properties. The very high-resolution images together with the colour and stereo capabilities of the camera will be of unprecedented quality for the identification of water-related surface features like sedimentary rocks.

Any qualified search for extant or extinct life requires a careful survey of the ExoMars rover traverse (in fact, such a survey will determine the traverse). The survey will provide geological and topographical data and should aim to achieve several tasks (the following list is slightly modified from Westall et al. (2000), here we list only the bullets which will be addressed by PanCam observations):

- identify the position of the landing site and determine the rover traverse;

- provide an assessment of the rock density at each site;
- determine the rock distribution and its heterogeneity;
- determine the rock size distribution and assess the evidence for bi- or multi-modal distribution caused by different geological processes;
- study the evidence for macroscopic environmental influences on the site (e.g. flooding, impact, volcanism, etc.);
- investigate aeolian effects (e.g., ripples, wind tails, ventifacts) for comparisons with global circulation models;
- study the surface photometric function;
- investigate the bulk mineralogy of rocks and soils;
- search for spectral inhomogeneities of soils and compare this to the local morphology;
- search for spectral inhomogeneities of rocks and investigate evidence for sedimentation and an influx of external material;
- search for potential exobiological targets for the rover, including identification of unusual morphology, differentiate between weathered and unweathered rock, study significant colour differences, and
- identify potential dangers to navigation.

PanCam can perform these essential tasks during the survey of potential exobiological targets illustrating that a flexible, high-resolution colour imager is required for ExoMars. Selected bullet points are discussed in further detail below:

Multispectral Observations: Multi-wavelength imaging will provide an assessment of the mineralogic inventory of surface materials as well as their weathering state and possible past or present alteration processes (Smith et al., 1997a). The spectral information (see Table 1 for the

baseline filter wavelengths), recorded by the PanCam imaging system will be extremely interesting to compare with the Mars Pathfinder and Mars Exploration Rover (MER) results (Johnson et al., 1999, Squyres et al. 2004a,b). Rocks at the Pathfinder landing site have a relatively homogeneous composition which is rich in Silicon and poor in Magnesium (McSween et al., 1999), whereas at Meridiani Planum the rocks were often rich in sulphate salts with high levels of Mg (Squyres and Knoll, 2005).

Filter # ^a	CW ^b (nm)	PB ^c (nm)	Type	Filter # ^a	CW ^b (nm)	PB ^c (nm)	Type
L1 ^e	481	28	Geology	R1 ^e	720	560	CUL ^d
L2	439	22	Geology	R2	602	21	Geology
L3	532	32	Geology	R3	799	20	Geology
L4	750	18	Geology	R4	906	42	Geology
L5	857	34	Geology	R5	961	29	Geology
L6	930	32	Geology	R6	1003	28	Geology
L7	669	17	Geology/DEM	R7	668	17	DEM
L8	671	17	Far Stereo	R8	668	18	Far Stereo
L9	928	5.5	Solar	R9	440	22	Far Colour
L10	936	5.6	Solar	R10	532	32	Far Colour
L11	1000	6	Solar	R11	449	4	Solar
L12 ^f	877	6	Solar	R12 ^f	670	5.5	Solar

^a filter wheel location (L = left or FM-1, R = right or FM-2 camera);

^b CW = centre wavelength; ^c PB = pass band;

^d CUL = close-up lens (working distance is 8–9 cm),

^e selecting this filter causes the wiper to pass across the front window;

^f filter wheel reference home position.

Table 1. WAC baseline filter wavelengths (Beagle 2 stereo camera system heritage, see Griffiths et al. 2005). Note, that the Beagle 2 CUL (position R1) would be replaced by a clear filter.

At the Pathfinder landing site the composition of the dust is quite different from the rock composition and very similar to dust analysed at the Viking landing sites. This demonstrates that (1) dust is very homogeneous everywhere on Mars and (2) different compositional units exist elsewhere on the planet (Brückner et al., 1999). The characterisation of such units is a critical input for resolving the heterogeneity of the Martian crust and to locate sedimentary or at least water altered deposits. PanCam will observe the dust and rock colours at many sites and will provide clues about the compositional diversity of the upper Martian crust.

Aeolian Processes: Wind is known to be the dominant geologic process on the Martian surface (Greeley et al., 1992). Evidence for wind related surface features was visible in image data obtained by the Viking landers and by Pathfinder (Greeley et al., 1999). Recent high resolution images from the Mars Observer Camera (MOC) onboard Mars Global Surveyor reveal an abundance of eolian features like yardangs or dunes nearly everywhere on Mars (Malin et al., 1998), some of them are possibly active at present (Edgett and Malin, 1999). PanCam stereo data will allow measuring the orientations of wind drifts and ventifacts (Bridges et al., 1999) in digital elevation models at many locations along its traverse. Comparing the results to the orientation of wind streaks seen in orbiter images and to global circulation models (Haberle et al., 1999) will help to verify the models and to detect changes in the wind regime over time.

Even before the Pathfinder mission, dust devils were observed in Viking images (Thomas and Gierasch, 1985) and were considered as a triggering mechanism for dust storms. During the current MER missions dust devils have been observed many times, particularly by *Spirit* in the Gusev crater (Lemmon et al, 2006). PanCam will monitor the horizon for dust devils. By using the windowing techniques, only a thin horizontal band of pixels covering the horizon will be required, reducing the data volume needed to monitor dust devils.

Geological Context from Orbiter Data: High resolution orbiter images and spectral measurements will provide a regional context of the landing sites. Impact crater counts based on orbiter images will constrain the age of the landing sites (e.g., Neukum and Hiller, 1981). The comparison of morphological features at the landing sites with the regional topography derived from orbit by MOLA laser altimetry (Smith et al., 1998) and HRSC stereo imagery (e.g., Neukum et al., 1996) will lead to a better understanding of volcano-tectonic and erosional processes, material transport, and sedimentation. The mineralogical comparison of multispectral data from PanCam and from orbiting instruments such as the Thermal Emission Spectrometer (TES) onboard MGS

(Christensen et al., 1998) and especially the Omega mapping spectrometer onboard Mars Express (Bibring et al., 2004) and CRISM on Mars Reconnaissance Orbiter (Murchie et al., 2003) will help to reveal the origin and history of rocks and soils identified along the ExoMars rover traverse.

Atmospheric Studies: The major changes on the Martian surface that can be detected by PanCam are caused by aeolian processes and condensation of volatiles, which directly reflect variations in the prevailing near-surface wind regime, and the diurnal and seasonal volatile and dust cycles. Atmospheric studies will concentrate on the detection of clouds, measurements of the aerosol contents and the water vapour absorption at 936 nm (Titov, et al., 1999). Although currently present at ~30 ppm near the surface, the atmospheric water vapour distribution is vital to understanding water exchange with the regolith and loss to space. Understanding the water cycle at the ExoMars landing site will provide important clues to the question of extant life in the subsurface.

Scattering by dust particles (aerosols) controls the quantity of light in the sky and its spectral distribution (Thomas et al. 1999). Dust particles stripped from dust layers on the ground and ice, nucleated together, are important components of the aerosol-load in the atmosphere. The vertical optical depth of aerosols in the atmosphere of Mars varies strongly, depending on meteorological conditions such as temperature and atmospheric pressure. The results obtained at the Mars Pathfinder and MER landing sites on atmospheric conditions are summarised by Smith and Lemmon (1999), Tomasko et al. (1999) and Lemmon et al. (2006). PanCam will use images of the sky observed near sunrise or sunset to determine single scattering- and multiple scattering phase functions. The size-frequency distribution of aerosols with altitude can be estimated, when atmospheric layers at various altitudes are successively exposed to sunlight (Markiewicz et al., 1999).

Cloud observations, are also important since clouds play a crucial role in the dynamics of the Martian atmosphere, redistributing water vapour and removing dust from the atmosphere.

Condensation Processes: At the Viking 2 landing site, a bright condensate layer consisting of a mixture of CO₂- and H₂O-frost occurred during the first winter and remained there for 249 sols (Wall, 1981). The lifetime of the lower latitude Pathfinder camera was too short to detect any condensates, nor have the MERs detected any to date. PanCam will work over a planned lifetime of 180 sols at an as yet undecided landing site up to 45°N. It therefore maybe feasible to detect seasonal variations which affect the entire area of rover operations (the size of this area is <30 km) and to monitor the landing area for changes caused by condensation or sublimation of volatiles. Frost may also form on a daily basis due to extreme changes of local temperatures. Such changes may be detected during twilight using the PanCam blue filter channels.

Digital Elevation Models and Visualisation Tools

The primary reason for building a stereo camera system is to use the parallax between the images from each eye to recover the range to objects in the scene (Paar et al., 1999). Once distance measurements (as a function of azimuth and elevation) from panoramas of such stereo image pairs are converted to a digital elevation map (or DEM - with altitude as a function of latitude & longitude), it becomes possible to explore a virtual 3D model of the landscape around the rover.

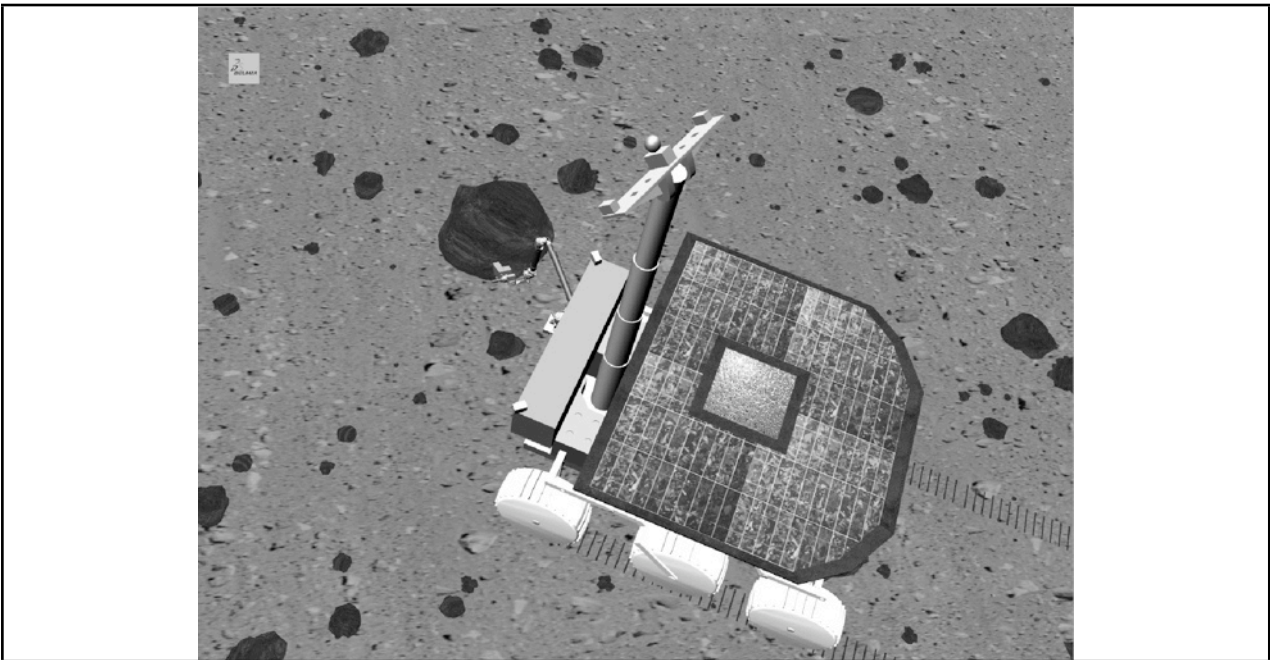

Fig. 3. Example of rover location external visualisation display (for the Astrium Phase A rover designs).

In addition to this DEM shape from stereo capability, PanCam operators will also have the facility to generate DEM data from single images using photoclinometric techniques. This so called “shape from shading” provides more accurate information on the high spatial frequencies (Barnes 2006, Cryer et.al., 1995) “than shape from stereo” but is less accurate for low spatial frequencies (and therefore complementary).

The analysis of the PanCam imagery will eventually result in the generation of precise 2 and 3D map products for the rover landing and exploration sites. To place in-situ measurements at a landing site into a proper regional context, it is necessary to determine the rover orientation on the ground and to exactly locate the position of the rover site with respect to the available cartographic database. Radio data from the rover alone does not have a sufficient precision to track the rover as it moves across the terrain. Images (including star images - e.g. Trautner, 2003) provided by the PanCam camera system will allow the accurate determination of the attitude (tilt and north

directions) of the ExoMars rover and the rover location based on landmarks visible to the camera which can also be recognised in orbital imagery.

Once a DEM of the rover's surroundings has been generated it will be fed to a suite of software visualisation tools. The aim of this software is to display an external view of the rover (based on the manufacturer's CAD model data - e.g. fig 3) at its current location, to display the foot prints of the remote sensing instruments and demonstrate the work space volumes of the deployable contact instruments. In addition to providing visualisations of the rover activities for public outreach purposes, such software is vital to enable the rover operators to correctly position both the rover and the contact instruments (including the drill) in order to achieve the mission science objectives.

Finally, although the autonomous "minute to minute" navigation decisions will be taken by onboard software based on images from the mast mounted stereo navigation cameras (and two pairs of body mounted forward and aft looking hazard cameras); in addition to providing a backup capability PanCam images will inform the ground based global navigation planning process. The PanCam team therefore intends to supply software tools to assist with incorporating PanCam images into this decision process (Paar et al., 1995, Kolesnik et al., 1998).

Conclusion

While not specifically a life detection instrument, this paper has demonstrated that the proposed Panoramic Camera for the ESA ExoMars rover will supply a vital part of the Pasteur payload. In addition to the obvious application to mission operations planning and providing the most easily appreciated data set in terms of public involvement with the mission; PanCam provides the first link in the Pasteur strategy for detecting evidence of biological activity on Mars. The primary scientific goals of PanCam are as follows (the last four items are also engineering objectives):

- Panoramic multispectral imaging for geological context
- High resolution imaging of targets of panorama interest and distant or hard to access features
- Mineralogy/petrology of soil, rocks and abraded surfaces
- Rock abundance and geologic study of rover traverse
- Search for evidence of biological activity from rock morphology
- Observation of drilling/coring activities (particularly spectral of drill tailings)
- Observation of drill sample before internal analyses
- Soil properties from rover tracks and borehole imaging
- Atmospheric water vapour distribution and dust/aerosol properties
- Multi-spectral observations of Phobos and Deimos
- DEM creation from stereo image pairs to determine local topography
- Coarse position location from astronomical observations
- Fine position location from comparison of PanCam DEM data and orbital imaging
- Support for route selection and navigation

The baseline PanCam design achieves these objective with a 65° FOV stereo pair of one megapixel CCD cameras (each equipped with a 12 position filter wheel - see table 1) producing DEMs and multispectral panoramas and a single 5° FOV high resolution camera to provide “zoomed-in” detail in colour on selected regions.

References

Barnes, D., Personal communication, 2006.

Bibring, J.-P.; Soufflot, A.; Berthé, M.; Langevin, Y.; Gondet, B.; Drossart, P.; Bouyé, M.; Combes, M.; Puget, P.; Semery, A.; Bellucci, G.; Formisano, V.; Moroz, V.; Kottsov, V.; Bonello, G.; Erard, S.;

- Forni, O.; Gendrin, A.; Manaud, N.; Poulet, F.; Poulleau, G.; Encrenaz, T.; Fouchet, T.; Melchiori, R.; Altieri, F.; Ignatiev, N.; Titov, D.; Zasova, L.; Coradini, A.; Capacionni, F.; Cerroni, P.; Fonti, S.; Mangold, N.; Pinet, P.; Schmitt, B.; Sotin, C.; Hauber, E.; Hoffmann, H.; Jaumann, R.; Keller, U.; Arvidson, R.; Mustard, J.; Forget, F., OMEGA: Observatoire pour la Minéralogie, l'Eau, les Glaces et l'Activité, in Mars Express: the scientific payload. Ed. by Andrew Wilson, scientific coordination: Agustin Chicarro. ESA SP-1240, p. 37 - 49, 2004.
- Bridges, N., Greeley, R., Haldemann, A.F.C., Herkenhoff, K., Kraft, M., Parker, T. and Ward, A., Ventifacts at the Pathfinder Landing Site. *J. Geophys. Res.* 104(E4), pp. 8595-8615, 1999.
- Brückner, J., Dreibus, G., Lugmair, G.W., Rieder, R., Wänke, H. and Economou, T., Chemical Composition of the Martian Surface as Derived from Pathfinder, Viking, and Martian Meteorite Data. *Lunar and Planetary Science XXX*, Abstract #1250. Lunar and Planetary Institute, Houston (CD-ROM), 1999.
- Christensen, P.R., Anderson, D.L., Chase, S.C., Clancy, R.T., Clark, R.N., Conrath, B.J., Kieffer, H.H., Kuzmin, R.O., Malin, M.C., Pearl, J.C., Roush, T.L. and Smith, M.D., Results from the Mars Global Surveyor Thermal Emission Spectrometer. *Science* 279, pp. 1692-1698, 1998.
- Cryer, J.E., et.al., Integration of Shape from Shading and Stereo, *Pattern Recognition*, Vol. 28, No. 7, pp. 1033-1043, 1995.
- Edgett, K.S. and Malin, M.C., MGS MOC The First Year: Sedimentary Materials and Relationships. *Lunar and Planetary Science XXX*, Abstract #1029, Lunar and Planetary Institute, Houston (CD-ROM), 1999.
- ESA Exobiology Team, Exobiology in the Solar System & The Search for Life on Mars, Report from the ESA Exobiology Team Study 1997—1998, Edited by A. Wilson, ESA Publications Division, SP-1231, 1999. Greeley, R., Lancaster, N., Lee, S. and Thomas, P., Martian Aeolian Processes, Sediments and Features. In *Mars* (edited by Kieffer et al.), pp. 730-766. University of Arizona Press, Tucson, 1992.
- Greeley, R., Kraft, M., Sullivan, R., Wilson, G., Bridges, N., Herkenhoff, K., Kuzmin, R.O., Malin, M. and Ward, W., Aeolian Features and Processes at the Mars Pathfinder Landing Site. *J. Geophys. Res.* 104(E4), pp. 8573-8584, 1999.
- Griffiths, A.D., Coates, A.J., Josset, J.-L., Paar, G., Hofmann, B., Pullan, D., Ruffer, P., Sims, M.R., Pillinger, C.T., The Beagle 2 stereo camera system, *Planet. Space Sci.* 53, 1466 – 1488, 2005.
- Haberle, R.M., Joshi, M.M., Murphy, J.R., Barnes, J.R., Schofield, J.T., Wilson, G., Lopez-Valverde, M., Hollingsworth, J.L., Bridger, A.F.C. and Schaeffer, J., General Circulation Model Simulations of the Mars

- Pathfinder Atmospheric Structure Investigation/Meteorology Data. *J. Geophys. Res.* 104(E4), pp. 8957-8974, 1999.
- Jaumann, R., Langevin, Y., Hauber, E., Oberst, J., Grothues, H.-G., Hoffmann, H., Soufflot, A., Bertaux, J.-L., Dimarellis, E., Mottola, S., Bibring, J.-P., Neukum, G., Albertz, J., Masson, Ph., Pinet, P., Lamy, Ph., and Formisano, V., The Mars NetLander panoramic camera. *Planet. Space Sci.* 48, 1377-1392, 2000.
- Johnson, J.R., Kirk, R., Soderblom, L.A., Gaddis, L., Reid, R.J., Britt, D.T., Smith, P., Lemmon, M., Thomas, N., Bell III, J.F., Bridges, N.T., Anderson, R., Herkenhoff, K.E., Maki, J., Murchie, S., Dummel, A., Jaumann, R., Trauthan, F. and Arnold, G., Preliminary Results on Photometric Properties of Materials at the Sagan Memorial Station, Mars. *J. Geophys. Res.* 104(E4), pp. 8809-8830, 1999.
- Kolesnik, M., G. Paar, A. Bauer, M. Ulm, "Algorithmic Solution for Autonomous Vision-Based Off-Road Navigation", Proc. 12th Aerosense (SPIE), Orlando, Florida, April 13-17, 1998.
- Lemmon, M.T., and the Athena Science Team, Mars Exploration Rover atmospheric imaging: dust storms, dust devils, dust everywhere. Abstract #2181. Lunar and Planetary Institute, Houston (CD-ROM), 2006.
- Malin, M.C., Carr, M.H., Danielson, G.E., Davies, M.E., Hartmann, W.K., Ingersoll, A.P., James, P.B., Masursky, H., McEwen, A.S., Soderblom, L.A., Thomas, P., Veverka, J., Caplinger, M.A., Ravine, M.A., Soulanille, T.A. and Warren, J.L., Early Views of the Martian Surface from the Mars Orbiter Camera of Mars Global Surveyor. *Science* 279, pp. 1681-1685, 1998.
- Markiewicz, W.J., Sablotny, R.M., Keller, H.-U., Thomas, N., Titov, D. and Smith, P.H., Optical Properties of the Martian Aerosols as Derived from Imager for Mars Pathfinder Midday Sky Brightness Data. *J. Geophys. Res.* 104(E4), pp. 9009-9017, 1999.
- McSween, H.Y., Murchie, S.L., Crisp, J.A., Bridges, N.T., Anderson, R.C., Bell III, J.F., Britt, D.T., Brückner, J., Dreibus, G., Economou, T., Ghosh, A., Golombek, M.P., Greenwood, J.P., Johnson, J.R., Moore, H.J., Morris, R.V., Parker, T.J., Rieder, R., Singer, R. and Wänke, H., Chemical, Multispectral, and Textural Constraints on the Composition and Origin of Rocks at the Mars Pathfinder Landing Site. *J. Geophys. Res.* 104(E4), pp. 8679-8715, 1999.
- Murchie, S.; Arvidson, R.; Beisser, K.; Bibring, J.-P.; Bishop, J.; Boldt, J.; Bussey, B.; Choo, T.; Clancy, R. T.; Darlington, E. H.; Des Marais, D.; Fasold, M.; Fort, D.; Green, R.; Guinness, E.; Hayes, J.; Heyler, G.; Humm, D.; Lee, R.; Lees, J.; Lohr, D.; Malaret, E.; Morris, R.; Mustard, J.; Rhodes, E.; Robinson, M.; Roush, T.; Schaefer, E.; Seagrave, G.; Silvergate, P.; Smith, M.; Strohhahn, K.; Thompson, P.; Tossman, B., CRISM: Compact Reconnaissance Imaging Spectrometer for Mars on the

- Mars Reconnaissance Orbiter, Sixth International Conference on Mars, July 20-25 2003, Pasadena, California, abstract no.3062, 2003.
- Neukum, G., and Hiller, K., Martian Ages. *J. Geophys. Res.* 86, pp. 3097-3121, 1981.
- Neukum, G., Carsenty, U., Eichentopf, K., Hoffmann, H., Jaumann, R., Oberst, J., Pischel, R., and Schwarz, G., The Experiments HRSC and WAOSS on the Russian Mars 94/96 Missions. *Acta Astronautica* Vol. 38, No. 9, 713-720, 1996.
- Paar, G., Bauer, A. and Sidla, O., 1999, Near range stereo for Mars landing site reconstruction, *Proc. SPIE* 3827, 22 Industrial Lasers and Inspection, Munich, Jun. 14-17, 1999.
- Paar, G., O. Sidla, W. Pölzleitner, "Natural Feature Tracking for Autonomous Navigation", in *Proc. 28th ISATA Conference on Robotics, Motion and Machine Vision*, October 1995, Stuttgart, Germany.
- Smith, P.H., Tomasko, M.G., Britt, D., Crowe, D.G., Reid, R., Keller, H.U., Thomas, N., Gliem, F., Rueffer, P., Sullivan, R., Greeley, R., Knudsen, J.M., Madsen, M.B., Gunnlaugsson, H.P., Hviid, S.F., Goetz, W., Soderblom, L.A., Gaddis, L. and Kirk, R., The Imager for Mars Pathfinder Experiment. *J. Geophys. Res.* 102(E2), pp. 4003-4025, 1997a.
- Smith, P.H. and Lemmon, M., Opacity of the Martian Atmosphere Measured by the Imager for Mars Pathfinder. *J. Geophys. Res.* 104(E4), pp. 8975-8985, 1999.
- Smith, D.E., Zuber, M.T., Frey, H.V., Garvin, J.B., Head, J.W., Muhleman, D.O., Pettengill, G.H., Phillips, R.J., Solomon, S.C., Zwally, H.J., Banerdt, W.B. and Duxbury, T.C., Topography of the Northern Hemisphere of Mars from the Mars Orbiter Laser Altimeter. *Science* 279, pp. 1686-1692, 1998.
- Squyres, S.W. and the Athena Science Investigation team, The Spirit Rover's Athena Science Investigation at Gusev Crater, Mars, *Science* 305, pp. 794-799, 2004a.
- Squyres, S.W. and the Athena Science Investigation team, The Opportunity Rover's Athena Science Investigation at Meridiani Planum, Mars, *Science* 306, pp. 1698-1703, 2004b.
- Squyres, S.W. and Knoll, A.H., Sedimentary rocks at Meridiani Planum: Origin, diagenesis, and implications for life on Mars, *Earth & Planet. Sci. Letters* 240, pp.1-10, 2005.
- Thomas, N., Markiewicz, W.J., Sablotny, R.M., Wuttke, M.W., Keller, H.U., Johnson, J.R., Reid, R.J., and Smith, P.H., 1999, The colour of the Martian sky and its influence on the illumination of the Martian surface, *J. Geophys. Res.*, 104 (E4), 8795-8808, Apr. 25, 1999.
- Thomas, P. and Gierasch, P.J., Dust Devils on Mars. *Science* 230, 175-177, 1985.

- Titov, D.V., et al., 1999, Measurements of the atmospheric water vapour on Mars by the Imager for Mars Pathfinder, *J. Geophys. Res.*, 104 (E4), 9019-9026, Apr. 25, 1999.
- Tomasko, M.G., Doose, L.R., Lemmon, M., Smith, P.H. and Wegryn, E., Properties of Dust in the Martian Atmosphere from the Imager on Mars Pathfinder. *J. Geophys. Res.* 104(E4), pp. 8987-9007, 1999.
- Trautner, R., Manaud, N., Michael, G., Koschny, D., Griffiths, A., Coates, A., Josset, J-L., Beauvivre, S., Determination of the Beagle2 Landing Site, Proceedings of International Workshop on Planetary Probe Atmospheric Entry and Descent Trajectory Analysis and Science, 6 – 9 October 2003, Lisbon, Portugal, Edited by A. Wilson. ESA SP-544, pp. 175-181, 2004.
- Vago, J.L., ExoMars Science Management Plan, EXM-MS-PL-ESA-00002, 2005.
- Wall, S.W., Analysis of Condensates Formed at the Viking 2 Lander Site: The First Winter. *Icarus* 47, pp. 173-183, 1981.
- Westall, F., Brack, A., Hofmann, B., Horneck, G., Kurat, G., Maxwell, J., Ori, G. G., Pillinger, C., Raulin, F., Thomas, N., Fitton, B., Clancy, P., Prieur, D., and Vassaux, D., An ESA Study for the Search for Life on Mars, *Planet. Space Sci.* 48, 181-202, 2000.