

IMPACT OF APPARENT REACTANCE INJECTED BY TCSR ON DISTANCE RELAY IN PRESENCE PHASE TO EARTH FAULT

Mohamed ZELLAGUI¹, Abdelaziz CHAGHI¹

¹LSP-IE Research Laboratory, Department of Electrical Engineering, Faculty of Technology, University of Batna, Campus CUB, Street Med El Hadi Boukhrouf, 050 00, Batna, Algeria

m.zellagui@gmail.com, az_chaghi@univ-batna.dz

Abstract. *This research paper presents the impact study of apparent reactance injected by series Flexible AC Transmission System (FACTS) i.e. Thyristor Controlled Series Reactor (TCSR) on the measured impedance of a 400 kV single electrical transmission line in the presence of phase to earth fault with fault resistance. The study deals with an electrical transmission line of Eastern Algerian transmission networks at Group Sonelgaz (Algerian Company of Electrical) compensated by TCSR connected at the midpoint of the transmission line. This compensator used to inject voltage and reactive power is controlled by TCSR. The simulation results investigate the three impacts of the apparent reactance injected by TCSR (X_{TCSR}) on transmission line protected by distance relay protection. The impacts concern the active and reactive power, the line impedance (reactance and resistance), and the short circuit parameters (symmetrical currents, line currents, symmetrical voltages and line voltages as well as the measured impedance by relay (resistance and reactance) in the presence of earth fault. These impacts are investigated in order to improve the performances of distance relay protection. More the impact of X_{TCSR} by three TCSR for cases studies is presented.*

Keywords

Apparent reactance, distance protection, earth fault, measured impedance, symmetrical components, TCSR, transmission line.

1. Introduction

Electrical power systems have to be planned, projected, constructed, commissioned and operated in such a way to enable a safe, reliable and economical supply of the load. The knowledge of the equipment loading at the time of commissioning, the prediction is necessary in

the future for the design and determination of the rating of the individual equipment and of the power system as a whole. Faults, i.e., short-circuits in the power system cannot be avoided despite careful planning and design, good maintenance and thorough operation of the system. This implies influences from outside the system, such as faults following lightning strokes into phase-conductors of overhead lines and damages of cables due to earth construction works as well as internal faults due to ageing of insulation materials [1]. Fault currents therefore have an important influence on the design and operation of power systems equipment. More than 83 % of the occurred faults on the 220 and 400 kV overhead transmission networks in Algerian Company of Electrical and Gas [2] are single phase to ground type.

Distance protection relays have been widely applied as the primary protection in high voltage transmission lines due to their simple operating principle and capability to work independently under most circumstances [3]. The basic operation principle of distance relay is based on the fact that the line impedance is fairly constant with respect to the line length. However, the implementation of FACTS controllers in power system transmission for enhancing the power system controllability and stability have introduced new power system issues in the field of power system protection that must be considered and analyzed [4].

There are two generations for realization of power electronics based FACTS controllers: the first generation employs conventional thyristors switched capacitors and reactors, and quadrature tap-changing transformers while the second generation employs gate turn-off (GTO) thyristors switched converters as a voltage source converters (VSCs). The first generation has resulted in the Static Var Compensator (SVC), the Thyristor Controlled Series Capacitor (TCSC), the Thyristor Controlled Phase Shifter (TCPS), and the Thyristor Controlled Series Reactor (TCSR) [5]. The second generation has produced the Static Synchronous Compensator (STATCOM), the Static Syn-

chronous Series Compensator (SSSC), the GTO Controlled Series Capacitor (GCSC), the Unified Power Flow Controller (UPFC), and the Interline Power Flow Controller (IPFC) [6]. The two groups of FACTS controllers have distinctly different operating and performance characteristics. In the presence of series FACTS devices, the conventional distance relay characteristics such as MHO and quadrilateral are greatly subjected to mal-operation in the form of overreaching or underreaching the fault point [7]. Therefore, the conventional relay characteristics may not work properly in the presence of FACTS device.

The presence of the FACTS devices in the faulted loop introduces changes to the line parameters seen by the distance relay. The impact of FACTS device would affect both the steady state and transient trajectory of the apparent impedance seen by distance relays due to the fast response time of FACTS controllers with respect to that of the protective devices. The impact of FACTS devices on distance protection varies depending on the type of FACTS device used, the application for which it is applied and the location of the FACTS device in the power system, the performance evaluation of distance protection scheme in the presence of FACTS controllers, which affect the apparent impedance calculations at relay point, has been carried out in [7]. The apparent impedance calculations are generally carried out using power frequency components of voltage and current measured at relay point.

The impact of the first generation on distance protection has been reported for general research on the influence of SVC on the transmission lines protection in [8] while the impact for apparent substance injected on measured impedance (Z_{seen}) in presence inter phase faults for different locality, and in reference [9] comparing effects of two types for SVC (TCR and TSC) on MHO distance protection setting zone in 400 kV Algerian transmission line. The general impact of TCSC on the transmission line protection is the study in [10] while the impact on communication-aided distance protection schemes and its mitigation is reported in [11]. In [12] the Z_{seen} by distance relay for inter phase faults with TCSC on a double transmission line high voltage is being studied and in [13] the variation of Z_{seen} by distance relay for inter phase faults in the presence of TCSC on adjacent transmission line by considering MOV Operation is investigated. The effects of voltage transformers connection point on Z_{seen} at relaying point for inter phase faults is also reported in [14]. Comparing TCSC placements on double circuit line at mid-point and at ends from measured impedance point of view is mentioned in [15], and impact of TCSC on Z_{seen} by MHO distance relay on 400 kV Algerian transmission line in the presence of phase to earth fault with fault resistance is reported in [16]. For the impact of TCSC on distance protection in

[17] is studying the new settings zones for distance relay based Artificial Neural Network (ANN) technique on a single transmission line.

The impact of second generation, specially the STATCOM is studying the performance evaluation of distance protection scheme which affect the apparent impedance calculations at relay point, has been carried out in [18], and the impact for apparent substance injected on Z_{seen} in presence inter phase faults is also reported [19]. The general impact of SSSC on the transmission line protection is the study in [20] while the impact on fault condition on Z_{seen} in [21] is studying the locus of apparent impedance of distance protection while the impact on reactive power condition and in paper [22] is study the Z_{seen} in presence inter phase faults. For the impact of GCSC on the Z_{seen} by MHO distance protection for phase to earth fault in the presence with fault resistance is study in [23], [24]. The performance evaluation of fault component distance relay for protection of lines compensated by UPFC in [25], [26], and compensated by IPFC in [27].

In this research paper, study the impact of apparent reactance injected by three TCSR on Algerian transmission line protected by distance relay protection in presence single phase (phase A) to earth fault with fault resistance have been investigated in order to improve the performances of relay. The three impacts study is:

- Impacts on active and reactive power of transmission line protected at load busbar, and the parameters on protected transmission line.
- Impact on the parameters of short circuit calculation: symmetrical components of currents and voltage, line currents and voltages.
- Impacts on parameters of measured impedance by distance relay (resistance and reactance).

2. Apparent Reactance Injected by TCSR on Transmission Line

The compensator TCSR mounted on Fig. 1 consists of variable inductance (L_1) connected in a series with the transmission line controlled by thyristors mounted in anti-parallel and controlled by a firing angle (α) which varies between 90° and 180° , and a fixed value inductance (L_2) connected in shunt [6], [28].

This compensator can be modeled as a variable reactance (X_{TCSR}) as shows in Fig. 2.

From Fig. 2, the apparent reactance of the TCSR injected on transmission line is defined by the following

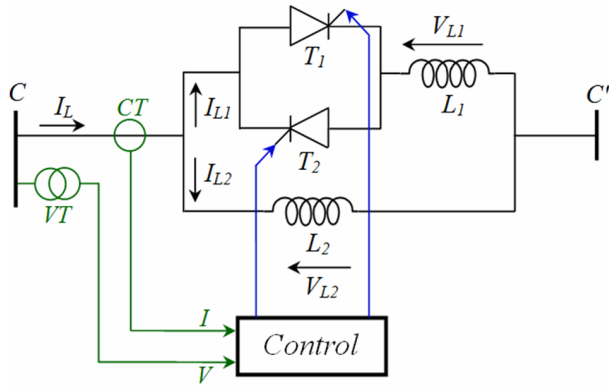

Fig. 1: Principal operation of TCSR.

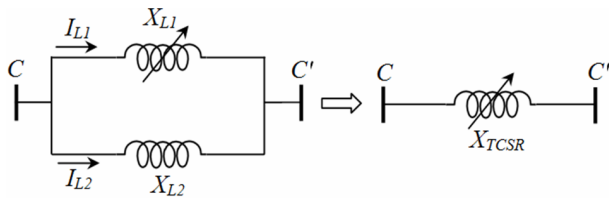

Fig. 2: Apparent reactance injected by TCSR.

equation [6], [17], [28]:

$$X_{TCSR}(\alpha) = X_{L1}(\alpha) // X_{L2} = \frac{X_{L1}(\alpha)X_{L2}}{X_L(\alpha) + X_{L2}} \quad (1)$$

The reactance of the first inductance \$X_{L1}(\alpha)\$ controlled by thyristors is defined by equation:

$$X_{L1}(\alpha) = X_{L1-max} \left[\frac{\pi}{\pi - 2\alpha - \sin(2\alpha)} \right], \quad (2)$$

where

$$X_{L1-max} = L_1 \cdot \omega. \quad (3)$$

And the second reactance of inductance (\$X_{L2}\$) is defined by the formula:

$$X_{L2} = L_2 \cdot \omega. \quad (4)$$

From Eq. (2) and (4), the final equation Eq. (1) becomes:

$$X_{TCSR}(\alpha) = \frac{L_2 L_1 \omega^2 \left(\frac{\pi}{\pi - 2\alpha - \sin(2\alpha)} \right)}{\omega \left(L_2 + L_1 \left(\frac{\pi}{\pi - 2\alpha - \sin(2\alpha)} \right) \right)}. \quad (5)$$

The active (\$P\$) and reactive (\$Q\$) powers on transmission line with TCSR are defined by following equations:

$$P(\delta) = \frac{V_A \cdot V_B}{Z_{AB} + X_{TCSR}(\alpha)} \sin(\delta), \quad (6)$$

$$Q(\delta) = \frac{V_B^2}{Z_{AB} + X_{TCSR}} - \frac{V_A \cdot V_B}{Z_{AB} + X_{TCSR}} \cos(\delta), \quad (7)$$

where, \$Z_{AB}\$ is impedance of transmission line, \$\delta\$ is line angle, \$V_A\$ and \$V_B\$ voltages on the extremity of transmission line.

3. Phase to Earth Fault Calculation in the Presence of a TCSR

Figure 3 shows transmission line in case of a single phase (phase A) to ground fault at busbar B with fault resistance (\$R_F\$) in the presence of a series compensator TCSR inserted on the midline, while Fig. 4 shows the equivalent circuit.

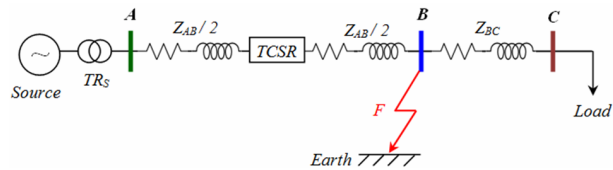

Fig. 3: Transmission line with TCSR.

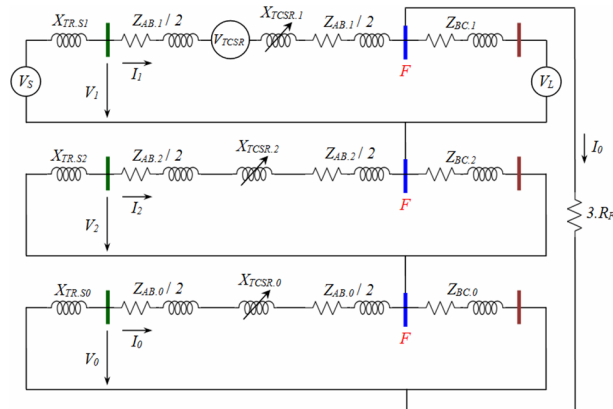

Fig. 4: Earth fault equivalent circuit with TCSR.

With TCSR inserted in the midline, the new impedance of transmission line (\$Z_{AB-TCSR}\$) is:

$$Z_{AB-TCSR} = R_{AB} + j [X_{AB} + X_{TCSR}(\alpha)]. \quad (8)$$

The basic equations for this type of earth fault [16], [29], [30] are:

$$I_b = I_c = 0. \quad (9)$$

$$V_a = V_1 + V_2 + V_0 = R_F \cdot I_a \neq 0. \quad (10)$$

The symmetrical components of currents are:

$$\begin{bmatrix} I_0 \\ I_1 \\ I_2 \end{bmatrix} = \frac{1}{3} \begin{bmatrix} 1 & 1 & 1 \\ 1 & a & a^2 \\ 1 & a^2 & a \end{bmatrix} \begin{bmatrix} I_A \\ I_B \\ I_C \end{bmatrix}. \quad (11)$$

From Eq. (9) and matrix (11), the symmetrical components of currents become:

$$I_1 + I_2 + I_0 = \frac{I_A}{3}. \quad (12)$$

The symmetrical components of voltages are:

$$\begin{bmatrix} V_0 \\ V_1 \\ V_2 \end{bmatrix} = \frac{1}{3} \begin{bmatrix} 1 & 1 & 1 \\ 1 & a & a^2 \\ 1 & a^2 & a \end{bmatrix} \begin{bmatrix} V_A \\ V_B \\ V_C \end{bmatrix}. \quad (13)$$

From Eq. (10) and matrix (13), the direct components of voltage become:

$$V_1 = -(V_0 + V_2) + R_F \cdot I_A, \quad (14)$$

and

$$\begin{aligned} V_s + V_{TCSR} - I_1 \left[\frac{Z_{AB.1}}{2} + X_{TCSR.1} + \frac{Z_{AB.1}}{2} \right] &= \\ &= A + B + C, \end{aligned} \quad (15)$$

where, the coefficients A , B and C are defined as:

$$A = -\frac{1}{3} \left[-\left(\frac{Z_{AB.0}}{2} + X_{TCSR.0} + \frac{Z_{AB.0}}{2} \right) \cdot I_0 \right], \quad (16)$$

$$B = -\frac{1}{3} \left[-\left(\frac{Z_{AB.2}}{2} + X_{TCSR.2} + \frac{Z_{AB.2}}{2} \right) \cdot I_2 \right], \quad (17)$$

$$C = R_F \cdot I_A. \quad (18)$$

The coefficients Z_{AB-T} and Z_{TCSR-T} are defined for simplicity as:

$$Z_{AB-T} = Z_{AB.1} + Z_{AB.2} + Z_{AB.0}. \quad (19)$$

$$X_{TCSR-T} = X_{TCSR.1} + X_{TCSR.2} + X_{TCSR.0}. \quad (20)$$

$$\begin{aligned} V_s + V_{TCSR} &= \\ \frac{I_A}{3} \left[\frac{Z_{AB-T}}{2} + X_{TCSR-T} + \frac{Z_{AB-T}}{2} \right] + R_F \cdot I_A. \end{aligned} \quad (21)$$

From Eq. (19), (20) and (21), the current at phase (A) currents in presence TCSR on midline is given by:

$$I_A = \frac{3 \cdot (V_s + V_{TCSR})}{\left(\frac{Z_{AB-T}}{2} \right) + X_{TCSR-T} + \left(\frac{Z_{AB-T}}{2} \right) + 3 \cdot R_F}. \quad (22)$$

From Eq. (12), the symmetrical components of currents in presence TCSR on midline are:

$$\begin{aligned} I_1 = I_2 = I_0 &= \\ \frac{V_s + V_{TCSR}}{\left(\frac{Z_{AB-T}}{2} \right) + X_{TCSR-T} + \left(\frac{Z_{AB-T}}{2} \right) + 3 \cdot R_F}. \end{aligned} \quad (23)$$

The direct components of voltages in presence TCSR are:

$$\begin{aligned} V_1 &= V_s + V_{TCSR} \\ &- \left(\frac{Z_{AB.1}}{2} + X_{TCSR.1} + \frac{Z_{AB.1}}{2} \right) \cdot I_1 \\ \Rightarrow V_1 &= \frac{(V_s + V_{TCSR}) \cdot [Z'_{AB} + X'_{TCSR} + 3 \cdot R_F]}{\frac{Z_{AB-T}}{2} + X_{TCSR-T} + \frac{Z_{AB-T}}{2} + 3 \cdot R_F}, \end{aligned} \quad (24)$$

where, the coefficients Z'_{AB} and X'_{TCSR} are defined as:

$$Z'_{AB} = Z_{AB.2} + Z_{AB.0} + 2 \cdot Z_{AB.1}. \quad (25)$$

$$X'_{TCSR} = X_{TCSR.2} + X_{TCSR.0} - 2 \cdot X_{TCSR.1}. \quad (26)$$

The inverse components of voltages in the presence TCSR are:

$$\begin{aligned} V_2 &= -\left(\frac{Z_{AB.2}}{2} + X_{TCSR.2} + \frac{Z_{AB.2}}{2} \right) \cdot I_2 \\ &\Rightarrow V_2 = \\ &-\frac{(V_s + V_{TCSR}) \cdot [Z_{AB.2} + X_{TCSR.2}]}{\left(\frac{Z_{AB-T}}{2} \right) + X_{TCSR-T} + \left(\frac{Z_{AB-T}}{2} \right) + 3 \cdot R_F}. \end{aligned} \quad (27)$$

The zero components of voltages in presence TCSR are:

$$\begin{aligned} V_0 &= -\left(\frac{Z_{AB.0}}{2} + X_{TCSR.0} + \frac{Z_{AB.0}}{2} \right) \cdot I_0 - R_F \cdot I_0 \\ &\Rightarrow V_0 = \\ &-\frac{(V_s + V_{TCSR}) \cdot [Z_{AB.0} + X_{TCSR.0} + R_F]}{\left(\frac{Z_{AB-T}}{2} \right) + X_{TCSR-T} + \left(\frac{Z_{AB-T}}{2} \right) + 3 \cdot R_F}. \end{aligned} \quad (28)$$

The coefficients Z'_{AB} and X'_{TCSR} are defined as:

$$Z'_2 = Z_{AB.2} + X_{TCSR.2}. \quad (29)$$

$$Z'_0 = Z_{AB.0} + X_{TCSR.0}. \quad (30)$$

$$S_a = 3 \cdot a^2 - 1. \quad (31)$$

$$S_b = 3 \cdot a - 1. \quad (32)$$

From Eq. (24), (27) and (28), the three phase voltages on transmission line in presence of TCSR are:

$$\begin{aligned} V_A &= \\ \frac{3 \cdot R_F \cdot (V_s + V_{TCSR})}{\left(\frac{Z_{AB-T}}{2} \right) + X_{TCSR-T} + \left(\frac{Z_{AB-T}}{2} \right) + 3 \cdot R_F}. \end{aligned} \quad (33)$$

$$\begin{aligned} V_B &= \\ \frac{(V_s + V_{TCSR}) \cdot [(a^2 - a)Z'_2 + (a^2 - 1)Z'_0 + S_b R_F]}{\left(\frac{Z_{AB-T}}{2} \right) + X_{TCSR-T} + \left(\frac{Z_{AB-T}}{2} \right) + 3 \cdot R_F}. \end{aligned} \quad (34)$$

$$\begin{aligned} V_C &= \\ \frac{(V_s + V_{TCSR}) \cdot [(a - a^2)Z'_2 + (a - 1)Z'_0 + S_b R_F]}{\left(\frac{Z_{AB-T}}{2} \right) + X_{TCSR-T} + \left(\frac{Z_{AB-T}}{2} \right) + 3 \cdot R_F}. \end{aligned} \quad (35)$$

4. Impedance Measured by Distance Relay Protection

The basic principle of distance protection involves the division of the voltage at the relaying point by the measured current. The apparent impedance so calculated is compared with the reach point impedance. If the measured impedance is less than the reach point impedance, it is assumed that a fault exists on the line between the relay and the reach point. The reach point of a relay is the point along the line impedance locus

that is intersected by the boundary characteristic of the relay. Distance relay has been widely used in the protection of transmission lines. The basic principle of operation of distance protection is shown in Fig. 5 [3].

The input to the distance relay point is the phase voltages and line currents transformed with the help of voltage transformer (VT) and current transformers (CT).

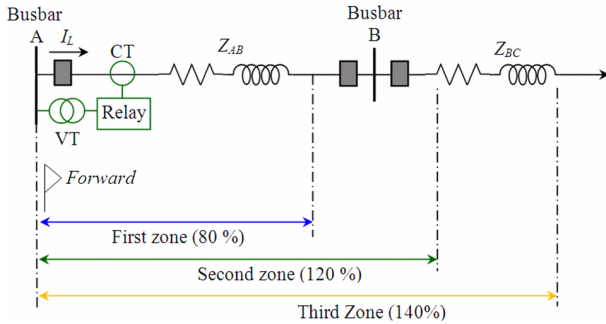

Fig. 5: Principal and setting zones for distance protection.

The total impedance of electrical transmission line AB measured by distance relay without fault is [16], [17], [24], and [31]:

$$Z_{seen} = K_Z \cdot Z_{AB} = (K_{VT}/K_{CT}) \cdot Z_{AB}, \quad (36)$$

where

$$K_{VT} = V_{prim}/V_{sec}, \quad (37)$$

and

$$K_{CT} = I_{prim}/I_{sec}. \quad (38)$$

The impedance Z_{AB} is real total impedance of protected transmission line AB, and K_{VT} and K_{CT} are a ratio of voltage to current transformers respectively.

The presence of TCSR, the X_{TCSR} has a direct influence on the total impedance of the protected line (Z_{AB}) by distance relay. This effect especially on the reactance X_{AB} and no influence on the resistance R_{AB} , it is represented in Fig. 6.

The voltage would fall towards zero at the point of the fault. In case of earth fault in phase (A), the impedance measured is calculated by flowing equation [3], [15], [16], [17], [18]:

$$Z_{seen} = \frac{V_{Relay}}{I_{Relay}} = \frac{V_A/I_A + K_o \cdot I_o}{K_Z} = R_{seen} + j \cdot X_{seen}, \quad (39)$$

where

$$K_o = \frac{Z_o - Z_1}{3 \cdot Z_1}, \quad (40)$$

and

$$K_Z = \frac{K_{CT}}{K_{VT}}. \quad (41)$$

The coefficient K_Z is a ratio of impedance transformers and K_o is coefficient for earth fault.

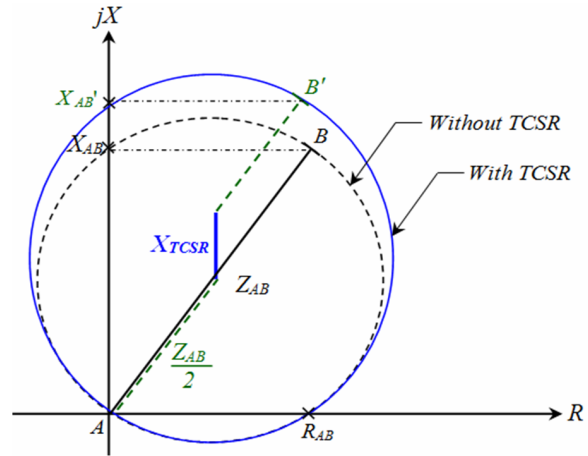

Fig. 6: Impact of the TCSR on total impedance.

5. Case Study, Results and Interpretations

The power system studied in this paper is the 400 kV Algerian electrical transmission networks at Algerian Company of Electrical and Gas (group Sonelgaz) which is shown in Fig. 7 [32].

The distance relay protection is located in the busbar at Ramdane Djamel substitution to protect transmission line between busbar A and busbar B respectively at Ramdane Djamel and Oued El Athmania substitution in Mila. The busbar C is located at Salah Bay substitution in Setif.

The series compensator TCSR is installed in midline. The parameters of transmission line are summarized in the appendix.

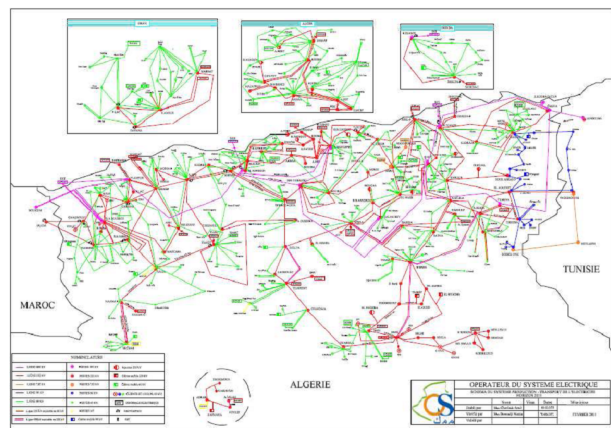

Fig. 7: Electrical networks study in presence TCSR [32].

Figure 8 shows the (a) X_{TCSR} , (b) V_{TCSR} and (c) Q_{TCSR} characteristics curves as a function of the firing angle (α) respectively of the three TCSR used in the case study.

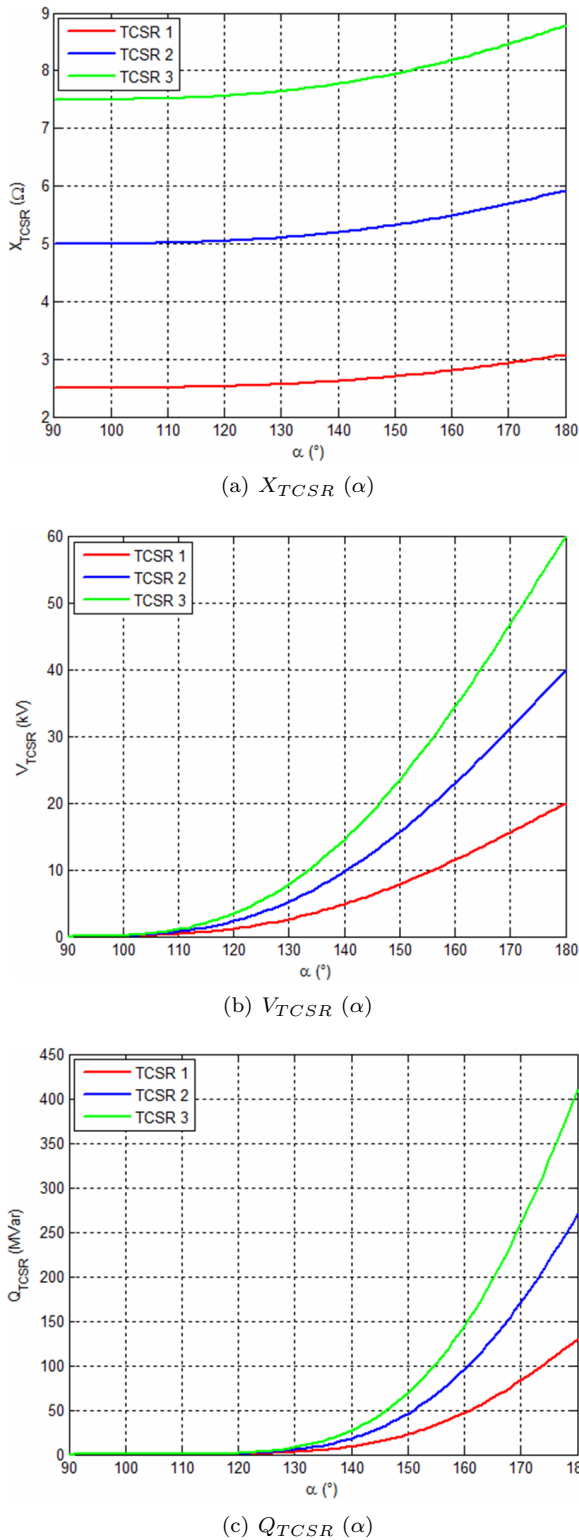

Fig. 8: Characteristic curve of TCSR study.

5.1. Impact on Protected Transmission Line

The Fig. 9(a) and 9(b) show the impact of TCSR insertion on the active and reactive power variation of

transmission line protected respectively at busbar B (load) with line angle (δ) varied between 0 to 180 °.

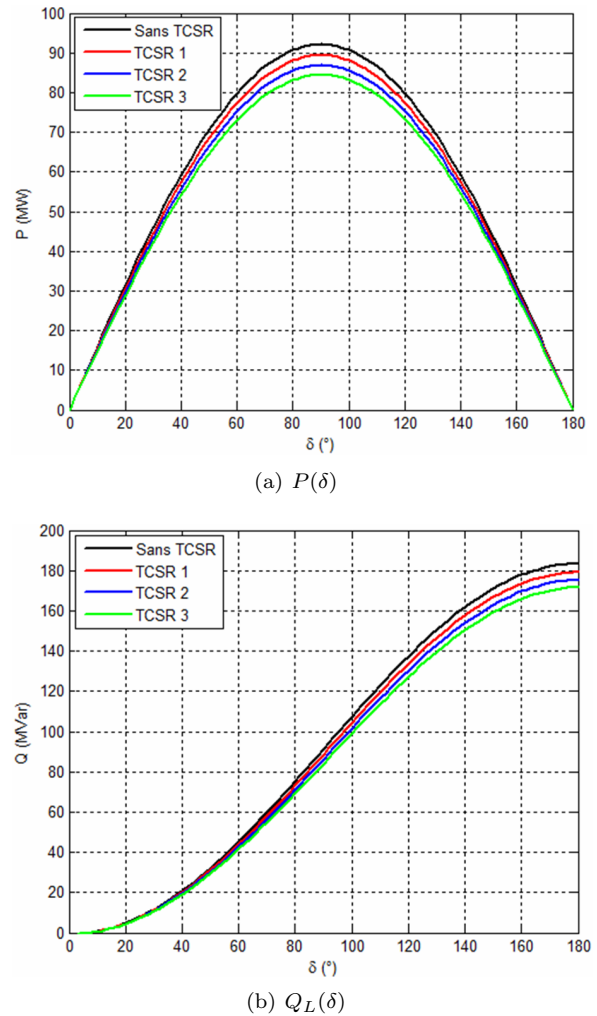
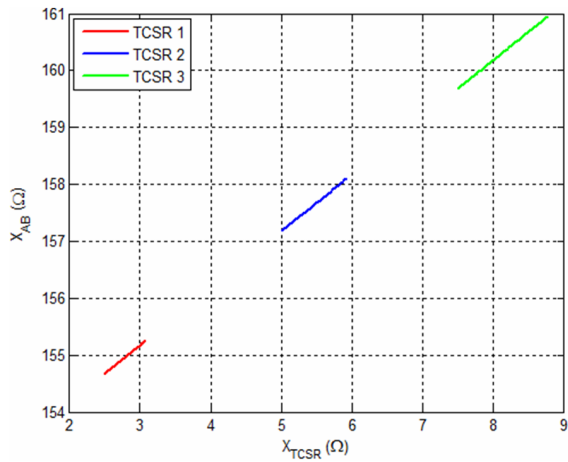

Fig. 9: Impact of TCSR on active and reactive power line.

In the presence of TCSR, the active and reactive power will be reduced following insertion of an inductive reactance in the middle point of the transmission line as show in Fig. 9.

The Fig. 10(a) and 10(b) show the impact of TCSR insertion on the parameters of protected transmission line: reactance (X_{AB}) and resistance (R_{AB}) respectively as a function of the apparent reactance injected (X_{TCSR}) by TCSR study.

From Fig. 10, the apparent reactance injected has a direct influence on the on the total impedance Z_{AB} . This effect is being observed especially on the reactance X_{AB} while there is no influence on the resistance R_{AB} .



(a) $R_{AB}(X_{TCSR})$

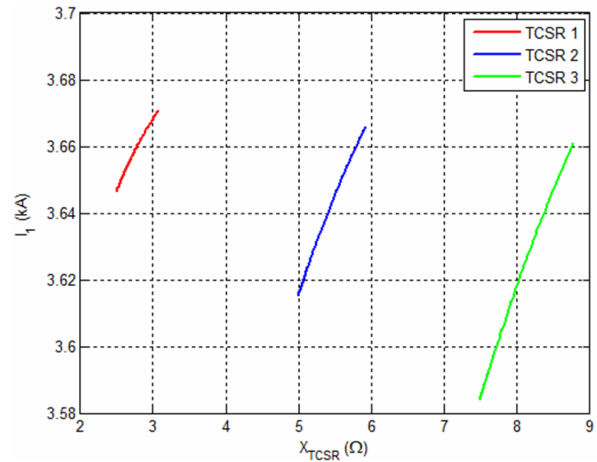

(a) $I_1 = f(X_{TCSR})$

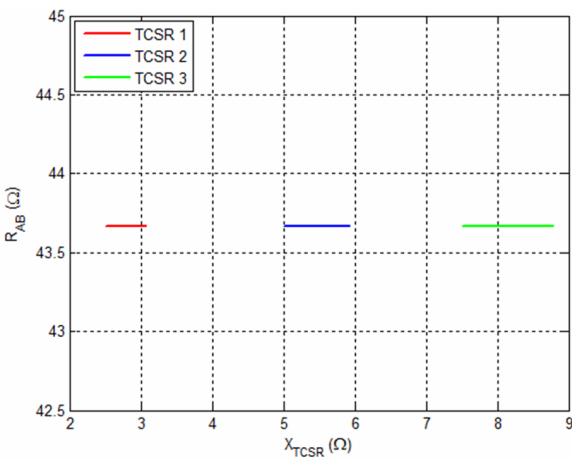

(b) $X_{AB}(X_{TCSR})$

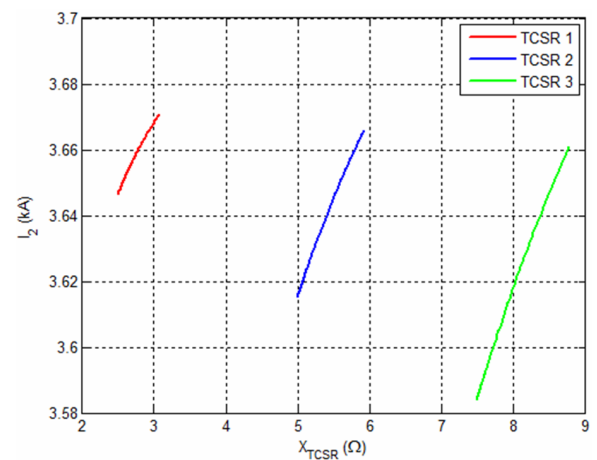

(b) $I_2 = f(X_{TCSR})$

Fig. 10: Impact of TCSR on reactance a resistance transmission line.

5.2. Impact on Short-Circuit Calculation

Figures 11(a), 11(b) and 11(c) represent the variation of the symmetrical component currents I_1 , I_2 and I_0 respectively and figures 12(a), 12(b) and 12(c) represent the variation of line current I_A , I_B and I_C respectively as a function of the apparent reactance injected by TCSR.

From Fig. 11 as can be seen, increasing the apparent reactance injected by TCSR also increases symmetrical currents for the three cases studied.

From Fig. 12 as can be seen as well, increasing apparent reactance injected by TCSR also increases line current in phase A, while line current in phases B and C remain zero value whatever the variation of the apparent reactance for the three cases studied.

Figures 13(a), 13(b) and 13(c) represent the variation of the symmetrical component voltages V_1 , V_2

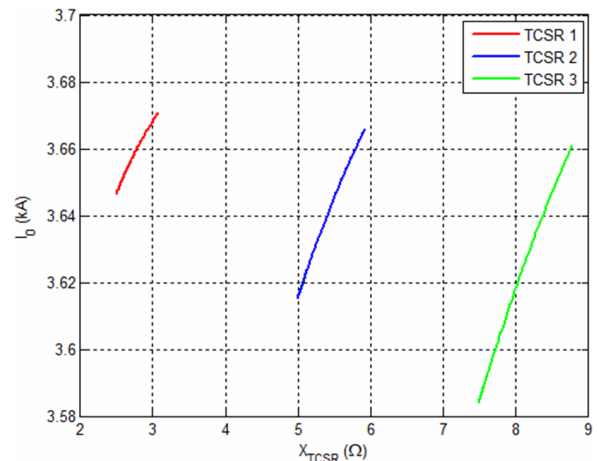

(c) $I_0 = f(X_{TCSR})$

Fig. 11: Impact of TCSR on symmetrical currents.

and V_0 respectively and Fig. 14(a), 14(b) and 14(c) represent the variation of line voltages V_A , V_B and V_C respectively as a function of the apparent reactance injected by TCSR.

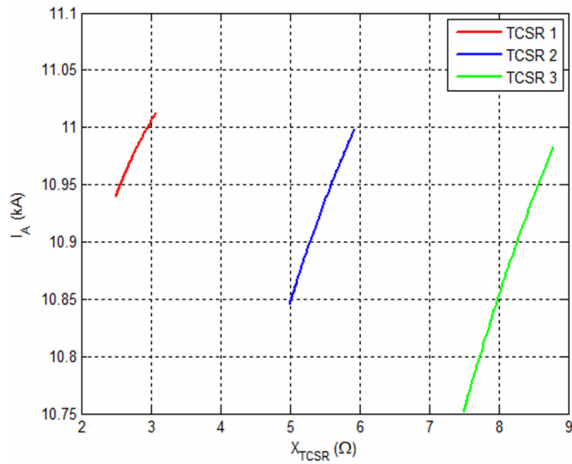

(a) $I_A = f(X_{TCSR})$

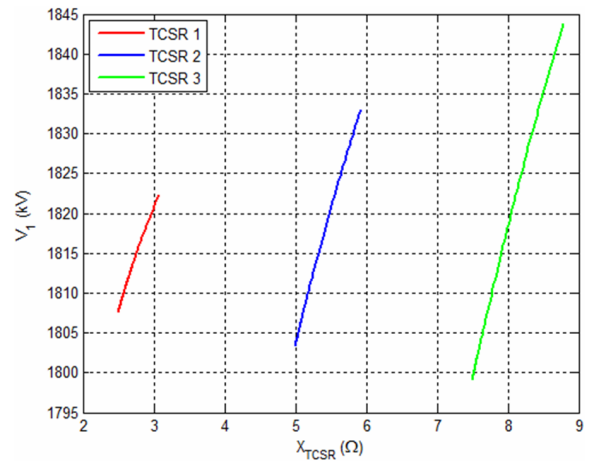

(a) $V_1 = f(X_{TCSR})$

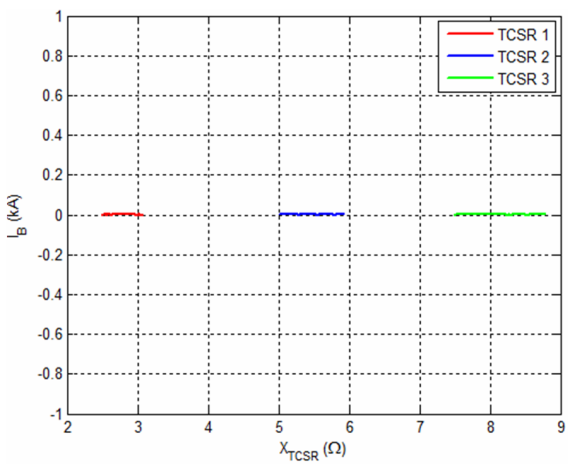

(b) $I_B = f(X_{TCSR})$

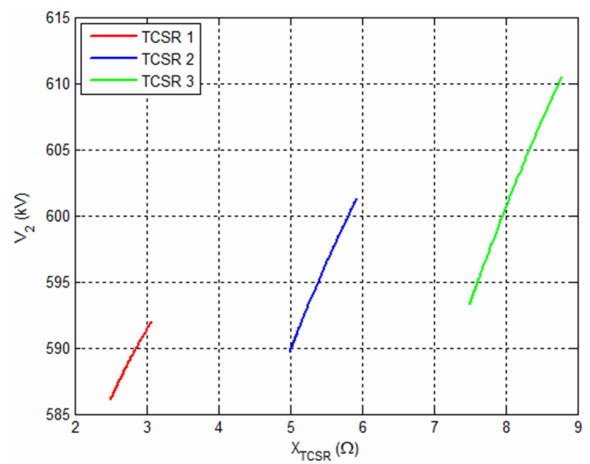

(b) $V_2 = f(X_{TCSR})$

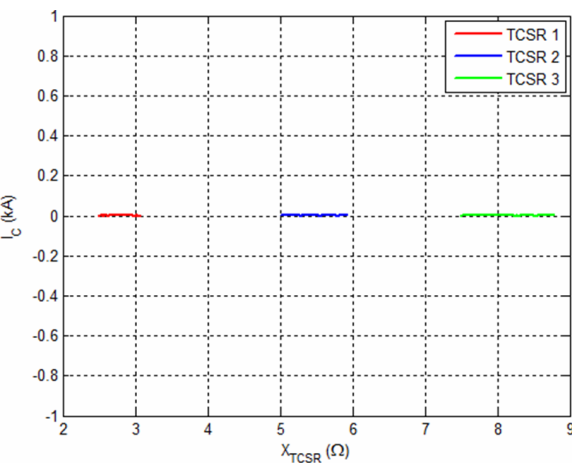

(c) $I_C = f(X_{TCSR})$

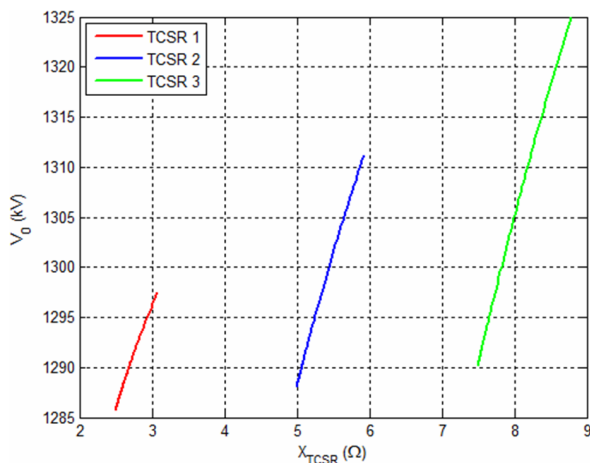

(c) $V_0 = f(X_{TCSR})$

Fig. 12: Impact of TCSR on transmission line currents.

Fig. 13: Impact of TCSR on symmetrical voltages.

From Fig. 13, increasing the apparent reactance injected by TCSR also increases symmetrical voltages for the three cases studied.

From Fig. 14, increasing the apparent reactance injected by TCSR also increase transmission line voltages for the three cases are studied.

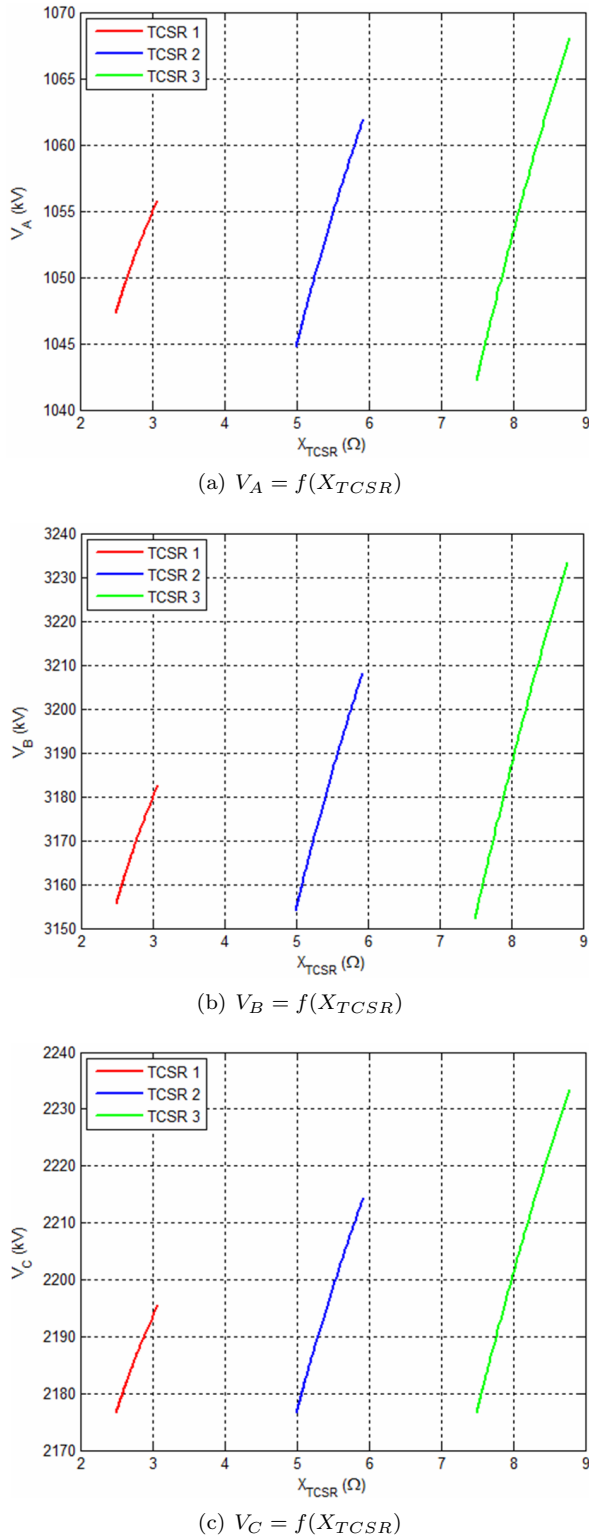

Fig. 14: Impact of TCSR on transmission line voltages.

5.3. Impact on the Measured Impedance

Figures 15(a) and 15(b) show the variation of resistance R_{seen} and reactance X_{seen} measured by distance relay

respectively as a function of reactance X_{TCSR} for different cases studied.

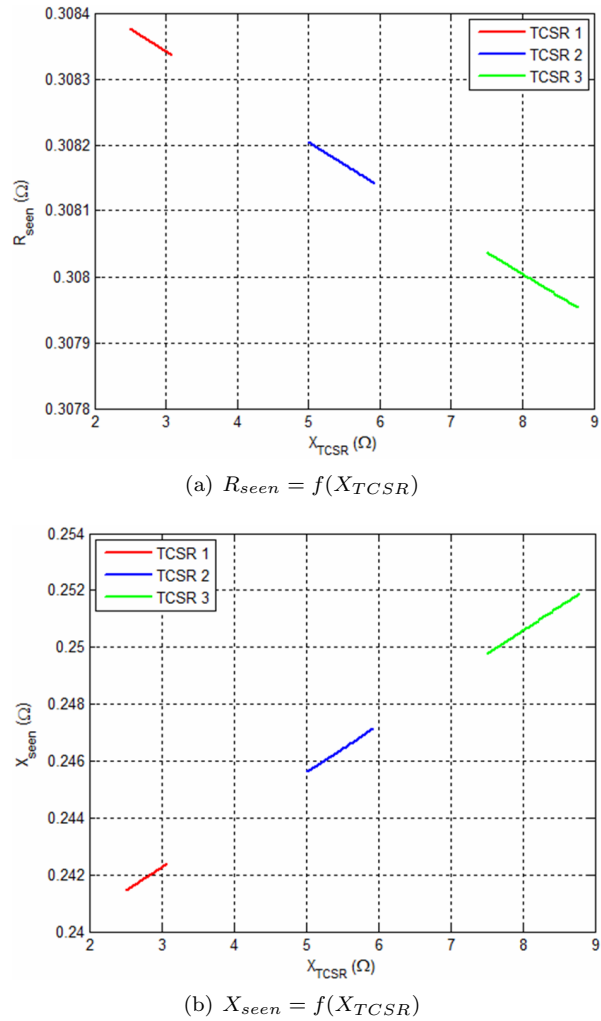

Fig. 15: Impact of the TCSR on the measured impedance.

From Fig. 15, increasing the apparent reactance decrease the resistance measured and increases the reactance measured by relay for the three cases study.

In presence TCSR for three cases studied the values of short-circuit calculation is varied between minimum and maximum value as reported in flowing Tab. 1.

Table 1 represents the minimum and maximum values for short circuit parameters. These values are important for calculating the settings for Overcurrent relay protection in the presence in case of ground fault, The new setting for transmission line composed by TCSR is between minimum and maximum value of fault current, where the courant $I_F = I_A$.

Table 2 represents the minimum and maximum values for impedance measured by distance relay protection. These values are important for calculating the settings zones parameters for distance relay protected

Tab. 1: Minimum and maximum value for short circuit parameters.

| | Case No. 1 | | Case No. 2 | | Case No. 3 | |
|-------------------------|------------|--------|------------|--------|------------|--------|
| | Min | Max | Min | Max | Min | Max |
| α ($^{\circ}$) | 90 | 180 | 90 | 180 | 90 | 180 |
| X_{TCSR} (Ω) | 2,500 | 3,070 | 5,000 | 5,920 | 7,500 | 8,780 |
| V_{TCSR} (kV) | 0,000 | 20,00 | 0,000 | 40,00 | 0,000 | 60,00 |
| Q_{TCSR} (MVar) | 0,000 | 130,0 | 0,000 | 270,0 | 0,000 | 410,0 |
| I_1 (kA) | 3,646 | 3,670 | 3,615 | 3,666 | 3,584 | 3,660 |
| I_2 (kA) | 3,646 | 3,670 | 3,615 | 3,666 | 3,584 | 3,660 |
| I_0 (kA) | 3,646 | 3,670 | 3,615 | 3,666 | 3,584 | 3,660 |
| I_A (kA) | 10,939 | 11,012 | 10,845 | 10,997 | 10,751 | 10,982 |
| I_B (kA) | 0,000 | 0,000 | 0,000 | 0,000 | 0,000 | 0,000 |
| I_C (kA) | 0,000 | 0,000 | 0,000 | 0,000 | 0,000 | 0,000 |
| V_1 (kV) | 1807,6 | 1822,3 | 1803,3 | 1833,0 | 1700,1 | 1843,7 |
| V_2 (kV) | 586,07 | 592,00 | 589,71 | 592,00 | 583,27 | 610,51 |
| V_0 (kV) | 1285,7 | 1297,4 | 1288,0 | 1311,2 | 1290,2 | 1324,9 |
| V_A (kV) | 1047,3 | 1055,7 | 1044,7 | 1061,9 | 1042,2 | 1068,0 |
| V_B (kV) | 3155,6 | 3182,6 | 3154,0 | 3207,9 | 3152,2 | 3233,1 |
| V_C (kV) | 2176,5 | 2195,4 | 2176,6 | 2214,3 | 2176,7 | 2233,4 |

Tab. 2: Minimum and maximum value of the measured impedance parameters by relay.

| | Case No. 1 | | Case No. 2 | | Case No. 3 | |
|-------------------------|------------|--------|------------|--------|------------|--------|
| | Min | Max | Min | Max | Min | Max |
| α ($^{\circ}$) | 90 | 180 | 90 | 180 | 90 | 180 |
| X_{TCSR} (Ω) | 2,500 | 3,070 | 5,000 | 5,920 | 7,500 | 8,780 |
| V_{TCSR} (kV) | 0,000 | 20,00 | 0,000 | 40,00 | 0,000 | 60,00 |
| Q_{TCSR} (MVar) | 0,000 | 130,0 | 0,000 | 270,0 | 0,000 | 410,0 |
| R_{seen} (Ω) | 0,3083 | 0,3084 | 0,3081 | 0,3082 | 0,3079 | 0,3080 |
| X_{seen} (Ω) | 0,2414 | 0,2424 | 0,2456 | 0,2471 | 0,2497 | 0,2519 |

transmission line compensated by series FACTS devices i.e. TCSR.

Practically the values for measured impedance represented in Tab. 1 and Tab. 2 are calculated by distance relay after the current and voltage measure in the presence of fault on transmission line.

6. Conclusion

A procedure of short circuit parameters calculation and measured impedance by distance relay of system with TCSR on transmission line 400 kV during single phase to ground fault with fault resistance is outlined. In this research paper, the effect of apparent reactance injected by TCSR on the impedance measured by protective relay protection is being considered.

The results are presented in relation to a typical electrical transmission system employing different TCSR (130 MVar/20 kV, 270 MVar/40 kV, 410 MVar/60 kV). The compensator is connected at the midpoint of a protected transmission line by distance relay. The simulation results show clearly the impact of TCSR on distance relay performance. The impedance Z_{seen} is influenced by the injected reactance X_{TCSR} of the TCSR. Since deviation of the measured impedance is not constant, because of the varying parameters of the injected

reactance by TCSR, adaptive methods should be utilized.

In order to increase the total system protection performance and avoid unwanted tripping of circuit breaker in the presence of series FACTS devices compensator on electrical transmission line care must be taken. For specified systems, settings for different protection zones can be achieved based on the proposed setting principles. Moreover following state of TCSR changing the setting relay of overcurrent protection is necessary.

Appendix

Power source:

$$U_s = 11 \text{ kV},$$

$$f_n = 50 \text{ Hz},$$

$$S_{TR} = 200 \text{ MVA}.$$

Power transformer:

$$U_{TR} = 11/400 \text{ kV},$$

$$\text{Coupling: Y}/\Delta,$$

$$S_{TR} = 200 \text{ MVA},$$

$$X_{TR1} = j0,235 \Omega,$$

$$X_{TR0} = j0,751 \Omega.$$

Transmission line:

$$U_L = 400 \text{ kV}, \Delta V = 35 \text{ kV}, \text{Length} = 360 \text{ km},$$

$Z_1 = 0, 1213 + j0, 4227 \Omega/\text{km}$,
 $Z_0 = 0, 3639 + j1, 2681 \Omega/\text{km}$.

TCSR study:

Case 1. $V_{Max} = 20 \text{ kV}$, $Q_{Max} = 130 \text{ MVar}$, $L_1 = 0, 0424 \text{ H}$, $L_2 = 0, 0080 \text{ H}$.

Case 2. $V_{Max} = 40 \text{ kV}$, $Q_{Max} = 270 \text{ MVar}$, $L_1 = 0, 1019 \text{ H}$, $L_2 = 0, 0159 \text{ H}$.

Case 3. $V_{Max} = 60 \text{ kV}$, $Q_{Max} = 410 \text{ MVar}$, $L_1 = 0, 1637 \text{ H}$, $L_2 = 0, 0239 \text{ H}$.

Fault conditions:

$n_F = 100 \%$,

$R_F = 0 \text{ to } 100 \Omega$.

References

- [1] SCHLABBACH, J. *Short-Circuit Currents*. 2. ed. London: Institution of Engineering and Technology, 2008. ISBN 9780863415142.
- [2] Group Sonelgaz/OS. *Rapport: Statistics of Faults on Electrical Networks 220 kV and 400 kV*. Algeria, 2012.
- [3] ZIGLER, G. *Numerical Distance Protection: Principles and Applications*. 3. ed. Munich: Publicis MCD, 2008. ISBN 978-3895781421.
- [4] IEEE Standard 1534. *IEEE Recommended Practice for Specifying Thyristor Controlled Series Capacitor*. New York: IEEE Power and Energy Society, 2009.
- [5] ZHANG, X. P., C. REHTANZ and B. PAL. *Flexible AC Transmission Systems: Modeling and Control*. Berlin: Springer Verlag, 2006. ISBN 978-3-642-06786-0.
- [6] MATHUR, R. M. and R. K. VARMA. *Thyristor-Based FACTS Controllers for Electrical Transmission Systems*. New York: John Wiley & Sons, 2002. ISBN 978-0-471-20643-9.
- [7] DASH, P. K., A. K. PRADHAN and G. PANDA. Apparent Impedance Calculations for Distance Protected Transmission Lines Employing Series-Connected FACTS Devices. *Electric Power Components and Systems*. 2001, vol. 29, no. 7, pp. 577–595. ISSN 1532-5016.
- [8] JAMALI, S., A. KAZEMI and H. SHATERI. Measured Impedance by Distance Relay for Inter Phase Faults in the Presence of SVC on Double-circuit Lines. In: *11th International Conference on Developments in Power Systems Protection, 2012. DPSP 2012*. Birmingham: IEEE, 2012, pp. 1–6. ISBN 978-1-84919-620-8. DOI: 10.1049/cp.2012.0052.
- [9] ZELLAGUI, M. and A. CHAGHI. Comparing Effects of TCR and TSC on MHO Distance Protection Setting in 400 kV Algerian Transmission Line. *Leonardo Electronic Journal of Practices and Technologies*. 2012, vol. 11, iss. 21, pp. 1–14. ISSN 1583-1078.
- [10] KHEDERZADEH, M. and T. S. SIDHU. Impact of TCSC on the Protection of Transmission Lines. *IEEE Transactions on Power Delivery*. 2006, vol. 21, iss. 1, pp. 80–87. ISSN 0885-8977. DOI: 10.1109/TPWRD.2005.858798.
- [11] SIDHU, T. S. and M. KHEDERZADEH. TCSC Impact on Communication Aided Distance Protection Schemes and Mitigation. *IEE Proceedings-Generation, Transmission and Distribution*. 2005, vol. 152, iss. 5, pp. 714–728. ISSN 1350-2360. DOI: 10.1049/ip-gtd:20045261.
- [12] JAMALI, S., A. KAZEMI and H. SHATERI. Measured Impedance by Distance Relay for Inter Phase Faults with TCSC on a Double Circuit Line. In: *18th Australasian Universities Power Engineering Conference AUPEC 2008*. Sydney: IEEE, 2008, pp. 1-6. ISBN 978-0-7334-2715-2.
- [13] JAMALI, S., A. KAZEMI and H. SHATERI. Measured Impedance by Distance Relay for Inter Phase Faults with TCSC on a Double Circuit Line. In: *IEEE Region 10 Conference TENCON 2008*. Hyderabad: IEEE, 2008, pp. 1–6. ISBN 978-1-4244-2408-5. DOI: 10.1109/TENCON.2008.4766724.
- [14] JAMALI, S., A. KAZEMI and H. SHATERI. Effects of Voltage Transformers Connection Point on Measured Impedance at Relaying Point for Inter Phase Faults in Presence of TCSC. In: *IEEE 2nd International on Power and Energy Conference, PECon 2008*. Johor Baharu: IEEE, 2008, pp. 553–558. ISBN 978-1-4244-2404-7. DOI: 10.1109/PECON.2008.4762537.
- [15] KAZEMI, A., S. JAMALI and H. SHATERI. Comparing TCSC Placements on Double Circuit Line Mid-point and Ends from Measured Impedance Point of View. In: *IEEE International Conference on Industrial Technology. ICIT'2008*. Chengdu: IEEE, 2008, pp. 1–6. ISBN 978-1-4244-1705-6. DOI: 10.1109/ICIT.2008.4608453.
- [16] ZELLAGUI, M. and A. CHAGHI. Impact of TCSC on Measured Impedance by MHO Distance Relay on 400 kV Algerian Transmission Line in Presence of Phase to Earth Fault. *Journal of Electrical Systems*. 2012, vol. 8, no. 3, pp. 273–291. ISSN 1112-5209.

- [17] ZELLAGUI, M. A. and CHAGHI. Distance Protection Settings Based Artificial Neural Network in Presence of TCSR on Electrical Transmission Line. *International Journal of Intelligent Systems and Applications*. 2012, vol. 4, no. 12, pp. 75–85. ISSN 2074-9058.
- [18] SHAM, M. V. and V. K. PANDURANGA. Simulation Studies on the Distance Relay Performance in the Presence of STATCOM. *Journal of Electrical Engineering*. 2011, vol. 11, no. 3, pp. 1–7. ISSN 1335-3632.
- [19] SALEMNI, A., M. KHEDERZADEH and A. GHORBANI. Impact of Static Synchronous Compensator (STATCOM) on Performance of Distance Relay. In: *IEEE PowerTech*. Bucharest: IEEE, 2009, pp. 1–8. ISBN 978-1-4244-2234-0. DOI: 10.1109/PTC.2009.5282187.
- [20] SHOJAEI, A., S. M. and MADANI. Analysis of Measured Impedance by Distance Relay in Presence of SSSC. In: *5th IET International Conference on Power Electronics, Machines and Drives (PEMD 2010)*. Brighton: IEEE, 2010, pp. 1–6. DOI: 10.1049/cp.2010.0113.
- [21] JAMALI, S. and H. SHATERI. Locus of Apparent Impedance of Distance Protection in the Presence of SSSC. *European Transactions on Electrical Power*. 2011, vol. 21, iss. 1, pp. 398–412. ISSN 1546-3109. DOI: 0.1002/etep.449.
- [22] JAMALI, S., A. KAZEMI and H. SHATERI. Measured Impedance by Distance Relay for Inter Phase Faults in Presence of SSSC. In: *IEEE/PES Power Systems Conference and Exposition, 2009 (PSCE 09)*. Seattle: IEEE, 2009, pp. 1–6. ISBN 978-1-4244-3810-5. DOI: 10.1109/PSCE.2009.4840123.
- [23] ZELLAGUI, M. and A. CHAGHI. Measured Impedance by MHO Distance Protection for Phase to Earth Fault in Presence GCSC. *ACTA Technica Corviniensis - Bulletin of Engineering*. 2012, vol. 5, iss. 3, pp. 81–86. ISSN 2067-3809.
- [24] ZELLAGUI, M. and A. CHAGHI. Impact of GCSC on Measured Impedance by Distance Relay in the Presence of Single Phase to Earth Fault. In: *32th International Conference on Power Systems Engineering*. Dubai: WASET, 2012, pp. 142–149. ISSN 2010-376X.
- [25] ZHOU, H., WANG, H., R. K. AGGARWAL and P. BEAUMONT. Performance Evaluation of a Distance Relay as Applied to a Transmission System With UPFC. *IEEE Transactions on Power Delivery*. 2006, vol. 21, iss. 3, pp. 1137–1147. ISSN 0885-8977. DOI: 10.1109/TPWRD.2005.861329.
- [26] KHEDERZADEH, M. Performance Evaluation of Fault Component Distance Relay for Protection of Lines Compensated by UPFC. In: *10th IET International Conference on Developments in Power System Protection (DPSP 2010)*. Manchester: IEEE, 2010, pp. 1–5. DOI: 10.1049/cp.2010.0248.
- [27] POUYAN, M., F. RAZAVI and M. RASHIDINEJAD. Performance of Distance Relays in Presence of IPFC. In: *IEEE Bucharest PowerTech*. Bucharest: IEEE, 2009, pp. 1–6. ISBN 978-1-4244-2234-0. DOI: 10.1109/PTC.2009.5282257.
- [28] SEN, K. K. and M. L. SEN. *Introduction to FACTS Controllers: Theory, Modeling and Applications*. New Jersey: John Wiley & Sons, 2009. ISBN 978-0470478752.
- [29] HA, H. X. and B. H. ZHANG. Study on Reactance Relays for Single Phase to Earth Fault on EHV Transmission Lines. In: *International Conference on Power System Technology*. Singapore: IEEE, 2004, pp. 1–5, vol.1. ISBN 0-7803-8610-8. DOI: 10.1109/ICPST.2004.1459956.
- [30] JAMALI, S. and H. SHATERI. Impedance based Fault Location Method for Single Phase to Earth Faults in Transmission Systems. In: *10th IET International Conference on Developments in Power System Protection (DPSP 2010)*. Manchester: IEEE, 2010, pp. 1–4. DOI: 10.1049/cp.2010.0351.
- [31] GERIN-LAJOIE, L. A MHO Distance Relay Device in EMTP Works. *Electric Power Systems Research*. 2009, vol. 79, no. 3, pp. 484–490. ISSN 0378-7796.
- [32] Group Sonelgaz/GRTE. *Topologies of Electrical Networks 400 kV*. Algerian Company of Electrical Transmission Network. Algeria, 2012.

About Authors

Mohamed ZELLAGUI was born in Constantine, Algeria, 1984. He received the engineer and M.Sc. degree in Electrical Engineering (Power System) from department of Electrical Engineering at University of Constantine, Algeria in 2007 and 2010 respectively, Ph.D. Student and member LSP-IE research laboratory from department of Electrical Engineering at Batna University, Algeria. Membership at International Association of Engineers (IAENG), and the Institution of Engineering and Technology (IET). His areas of interest include electrical networks, power system protection, distance relay and FACTS devices.

Abdelaziz CHAGHI was born in Batna, Algeria, 1954. He received his B.Sc. degree from the

University of Oran, Algeria 1980, and M.Sc. from the Manchester University, England 1984, and received his Ph.D. from Batna University, Algeria 2004. He is currently a Professor at department of Faculty of Technology, Electrical Engineering and member LSP-IE research laboratory at University of Batna. His areas of interest include power systems optimization, transmission line, harmonic, power quality and FACTS devices.