



# Durham E-Theses

---

## *Addition and some other reactions of sulphauric chloride*

Moore, L. F.

### How to cite:

---

Moore, L. F. (1967) *Addition and some other reactions of sulphauric chloride*, Durham theses, Durham University. Available at Durham E-Theses Online: <http://etheses.dur.ac.uk/8151/>

### Use policy

---

The full-text may be used and/or reproduced, and given to third parties in any format or medium, without prior permission or charge, for personal research or study, educational, or not-for-profit purposes provided that:

- a full bibliographic reference is made to the original source
- a [link](#) is made to the metadata record in Durham E-Theses
- the full-text is not changed in any way

The full-text must not be sold in any format or medium without the formal permission of the copyright holders.

Please consult the [full Durham E-Theses policy](#) for further details.

ADDITION AND SOME OTHER REACTIONS OF

SULPHANURIC CHLORIDE

by

L.F. MOORE. A.R.I.C.

The copyright of this thesis rests with the author.  
No quotation from it should be published without  
his prior written consent and information derived  
from it should be acknowledged.

A thesis submitted in candidature for the Degree of Doctor  
of Philosophy in the University of  
Durham.

September 1967



(i)

Acknowledgements

The author wishes to express his sincere thanks to Dr.A.J. Banister, under whose supervision this research was carried out, for his constant encouragement and advice; to the University of Durham for a Research Assistantship during the tenure of which this research was completed; and to the Science Research Council for financial support.

(ii)

Memorandum

The work described in this thesis was carried out in the University of Durham between October 1964 and August 1967. This work has not been submitted for any other degree and is the original work of the author except where stated by reference.

Parts of the work described in this thesis have been the subject of the following publications:

A.J.Banister, L.F.Moore and J.S.Padley, Chapter 5  
Inorganic Sulphur Chemistry, (Ed.G.Nickless),  
Elsevier, Amsterdam, (in press).

A.J.Banister, L.F.Moore and J.S.Padley, Spectrochim.  
Acta, 1967, (in press).

(iii)

### Summary

This thesis can conveniently be divided into four parts:

(i) Attempted syntheses of sulphanuric compounds, (ii) Addition reactions of sulphanuric chloride and other sulphur(VI) compounds, (iii) Other reactions of sulphanuric chloride, (iv) Spectroscopic studies on sulphur-oxygen and sulphur-nitrogen bonds.

(i) Attempted syntheses of sulphanuric compounds

The investigation of several routes is discussed. None of these routes lead to the formation of a sulphanuric derivative and, in particular, it is shown that the reaction by which sulphanuric chloride is prepared is not a general reaction for the preparation of other sulphanuric compounds.

(ii) Addition reactions of sulphanuric chloride and other sulphur(VI) compounds.

The reactions between sulphanuric chloride and donor molecules containing N, P, As and Sb are reported and discussed. It is shown that in general compounds of the type,  $3L.(NSOCl)_3$ , are formed, where L = tertiary amine or triphenyl phosphine, arsine or stibine. The possibility of strong C-H hydrogen bonding in the amine adducts is discussed. The acceptor properties of other compounds containing sulphur(VI) are examined; only for sulphuryl chloride are similar adducts formed, and these are less stable than are the compounds

(iv)

derived from sulphauric chloride. The reactions of sulphuryl chloride with triphenylarsine and triphenylstibine provide a new convenient synthesis of the triphenylarsine and triphenylstibine dichlorides. Sulphauric chloride also forms as an adduct with the  $\pi$ -donor, hexamethylbenzene.

(iii) Other reactions of sulphauric chloride.

Several attempted substitution reactions are reported. In general ring breakdown occurs though reaction with N,N diethylaminotrimethylsilane results in simple substitution. A brief investigation of the donor properties of sulphauric chloride is reported.

(iv) Spectroscopic studies on sulphur-oxygen and sulphur-nitrogen bonds.

The literature data is thoroughly reviewed, particularly with respect to inorganic compounds. Previously reported correlations for sulphur-oxygen compounds are confirmed and for sulphur-nitrogen compounds several new correlations are discussed.

(v)

Erratum

EXPERIMENTAL : p.122, 'The reaction between  $\alpha$ -sulphanuric chloride and hexamethylbenzene' is misplaced and should follow at the end of section d, p.110.

INDEX

INTRODUCTION

The aquo-ammonosulphuric acids and derivatives	1
Sulphamic acid	3
Sulphamide	5
Sulphimide and trisulphimide	8
Tetrasulphur tetranitride and the cyclic and acyclic sulphur-nitrogen halides and oxo-halides	
Tetrasulphur tetranitride	10
The cyclic sulphur-nitrogen halides and oxo-halides	
Tetrathiazyl tetrafluoride	16
Trithiazyl trifluoride	18
Trithiazyl trichloride	19
Sulphanuric chloride	22
Thiotrithiazyl compounds	28
The acyclic sulphur-nitrogen halides	
Thiazyl fluoride	31
Thiazyl chloride	32
Thiazyl bromide	34
Thiazyl trifluoride	32
Thiodithiazyl difluoride	34
Thiodithiazyl dichloride	35
Thiodithiazyl chloride	36



SPECTROSCOPIC STUDIES ON SULPHUR-OXYGEN AND  
SULPHUR-NITROGEN BONDS

Sulphur-oxygen bonds	38
Introduction	38
Sulphuryl compounds	39
Oxo-anions and complexes	46
(i) Sulphites	46
(ii) Sulphates	48
(iii) Thiosulphates	51
(iv) Other oxo-anions	52
Complexes containing oxo-anions as ligands	55
(i) Sulphito-complexes	55
(ii) Sulphato-complexes	56
Thionyl compounds	58
Correlations between stretching frequency and molecular parameters	61
Deformation frequencies	68
Sulphur-nitrogen bonds	69
Introduction	69
Discussion	70
Compounds containing the NSO group	81
<b>EXPERIMENTAL</b>	
(a) Apparatus and techniques	84
The nitrogen supply	84
The glove box	84

(viii)

Infrared spectroscopy	84
Mass spectroscopy	85
(b) The preparation and purification of starting materials and solvents	
The preparation of;	
Sulphamide	87
Ammonium trisulphimide	89
Silver trisulphimide	90
Benzenesulphinic acid	90
Benzenesulphanyl chloride	90
Benzenesulphenyl chloride	91
N,N diethylaminotrimethylsilane	91
Triphenylphosphine dichloride	92
Sulphanuric chloride	93
Pyridine-sulphur trioxide complex	95
Pyridine-selenyl chloride complex	96
Pyridine hydrochloride	96
(c) Attempted syntheses of the sulphanuric system.	
The reaction between thionyl chloride and;	
Ammonium trisulphimide	97
Silver trisulphimide	97
Ammonium chloride	100

(ix)

The reaction between sodium azide and;	
Thionyl chloride	98
Benzenesulphinyl chloride	99
Benzenesulphonyl chloride	99
The reaction between <i>p</i> -toluenesulphonamide and sulphamic acid	99
The reaction between phosphorus(V) chloride and,	
<i>p</i> -Toluenesulphonamide	100
<i>m</i> -Nitrobenzenesulphonamide	102
<i>p</i> -Chlorobenzenesulphonamide	103
<i>p</i> -Methoxybenzenesulphonamide	105
The reaction between <i>p</i> -toluenesulphonamide and triphenylphosphine dichloride	105
(d) Reactions between $\alpha$ -sulphanuric chloride and donor molecules	
The reaction between $\alpha$ -sulphanuric chloride and,	
Pyridine	106
<i>iso</i> -Quinoline	108
Trimethylamine	110
Triphenylphosphine	110
(e) Reactions between other sulphur(VI) compounds and donor molecules	
The reaction between sulphuryl chloride and,	
Pyridine	111

(x)

Triethylamine	113
Triphenylphosphine	114
Triphenylstibine	116
Triphenylarsine	117
The reaction between pyridine and,	
Pentafluorobenzenesulphonamide	117
Diphenyl sulphone	118
Sulphamide	118
Benzenesulphonamide	119
Benzenesulphonyl chloride	119
The reaction between benzenesulphonyl chloride and triphenylphosphine	120
(f) Thionyl chloride and phosphorus oxychloride as acceptor molecules	
The reaction between pyridine and,	
Thionyl chloride	121
Phosphorus oxychloride	121
(g) The donor properties of $\alpha$ -sulphanuric chloride	
The reaction between $\alpha$ -sulphanuric chloride and,	
Hexamethylbenzene	122
Beryllium chloride	124
Mercury(II) chloride	124
Titanium(IV) chloride	125
Niobium(V) chloride	125

(h) Metathesis reactions of  $\alpha$ -sulphanuric chlorideThe reaction between  $\alpha$ -sulphanuric chloride and,

Butyl lithium	126
Methyl lithium	126
Potassium thiocyanate	127
Phenylmagnesium bromide	127
N,N diethylaminotrimethylsilane	129

## DISCUSSION

A. Attempted syntheses of the sulphanuric system	130
B. The pyrolysis of aryl trichlorophosphazosulphones	137
C. Sulphanuric chloride as an acceptor molecule	146
D. Other sulphur(VI) compounds as acceptor molecules	155
E. Similar complexes of amines with elements other than sulphur	166
F. The amine adducts and dimethylsulphoxide	168
G. The pyrolysis of the amine adducts	169
H. $\pi$ -Complexes of $\alpha$ -sulphanuric chloride	171
I. $\alpha$ -Sulphanuric chloride as a donor molecule	172
J. Metathesis reactions of $\alpha$ -sulphanuric chloride	174
References	181

## Appendix 1

The reaction between  $\alpha$ -sulphanuric chloride and,

(a) Triphenylarsine	202
(b) Triphenylstibine	202

(xii)

Appendix 2: Structural Studies on Sulphur Species, by

A.J.Banister, L.F.Moore and J.S.Padley.

(uncorrected, first proofs).

**INTRODUCTION**

The compounds considered in this introduction fall conveniently into two classes. First, those compounds, e.g. sulphamic acid and sulphamide, which can be regarded as aquo-ammonosulphuric acids, and secondly, tetrasulphur tetranitride and the cyclic and acyclic sulphur-nitrogen halides and oxohalides. The cyclic trisulphimide, which is derived from sulphamide, is included in the first class though structurally it has some similarity to some of the compounds in the second class.

#### The aquo-ammonosulphuric acids and derivatives

Franklin<sup>1</sup> has suggested that the chemistry of a large number of (particularly) acyclic sulphur-nitrogen compounds may be rationalised if these are regarded as derivatives of a relatively small number of the so-called aquo-ammonosulphuric acids. These may be depicted diagrammatically as in Fig.1. Successive replacement of the hydroxyl groups in sulphuric acid by the isoelectronic  $\text{NH}_2$  group leads to sulphamic acid (1) and sulphamide (2), both of which are formally mixed aquo-ammonosulphuric acids. Imidosulphonic (3) and nitrilosulphonic (4) acids may be regarded as deammonation products of sulphamic acid. Imidodisulphamide (5), sulphimide (6) and trisulphimide (7) are similarly related to sulphamide. The arrangement shown in Fig.1 is reminiscent of the relationships which exist among the aquo-





ammonocarbonic acids, urea and cyanuric acid. This similarity is illustrated in Table 1 in which analogous compounds from the two systems are compared.

Fig.1.

The aquo-ammonosulphuric acids and derivatives.

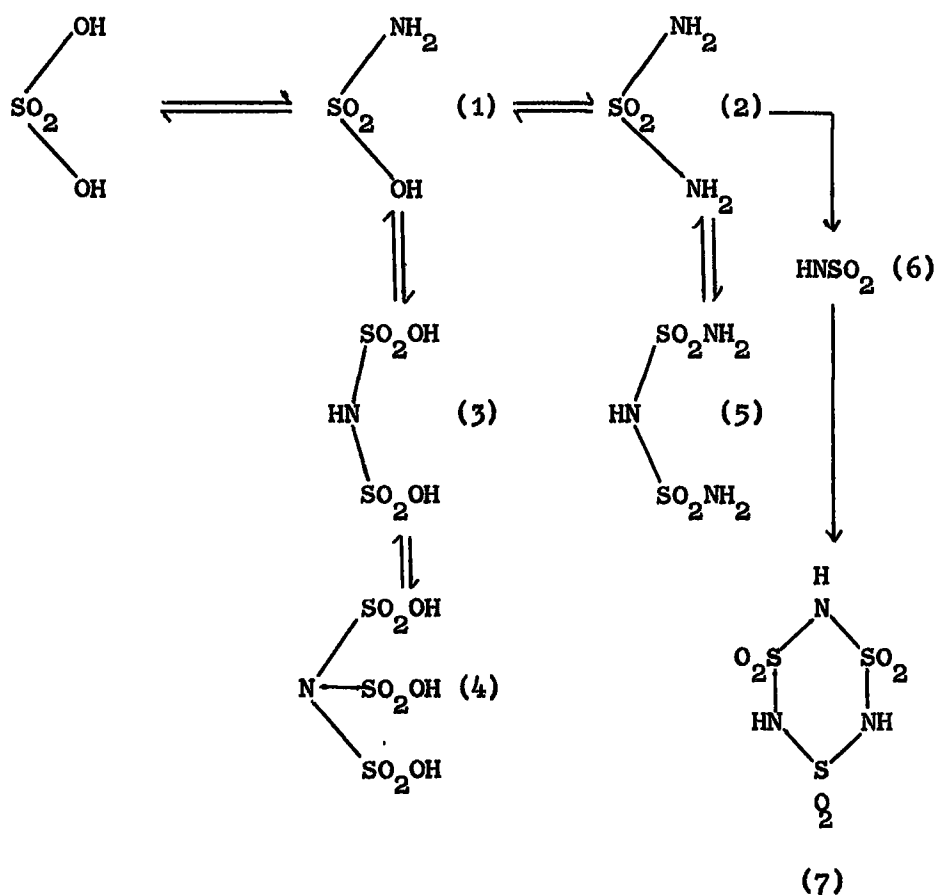

Audrieth et al.<sup>2</sup> have discussed the chemistry of these compounds in some detail and have shown that this apparent similarity

between the aquo-ammonosulphuric and aquo-ammonocarbonic acid system is not merely formal, but may be used to explain much of the chemistry of the former class of compounds.

Table 1

Mixed aquoammono acids related to sulphuric and carbonic acids.

	Related to $\text{SO}_2(\text{OH})_2$		Related to $\text{CO}(\text{OH})_2$
$\text{H}_2\text{N}\cdot\text{SO}_2\cdot\text{OH}$	sulphamic acid	$\text{H}_2\text{N}\cdot\text{CO}\cdot\text{OH}$	carbamic acid
$\text{H}_2\text{N}\cdot\text{SO}_2\cdot\text{NH}_2$	sulphamide	$\text{H}_2\text{N}\cdot\text{CO}\cdot\text{NH}_2$	urea
$\text{HN}\cdot(\text{SO}_2\text{NH}_2)_2$	imidodisulphamide	$\text{HN}\cdot(\text{CONH}_2)_2$	biuret
$\text{HN}\cdot(\text{SO}_2\text{OH})_2$	imidosulphonic acid	$\text{HN}\cdot(\text{CO}\cdot\text{OH})_2$	imidodicarbonic acid
$\text{HN}\cdot\text{SO}_2$	sulphimide	$\text{HN}\cdot\text{CO}$	cyanic acid
$(\text{HN}\cdot\text{SO}_2)_3$	trisulphimide	$(\text{HNCO})_3$	cyanuric acid

Sulphamic acid  $\text{H}_2\text{N}\cdot\text{SO}_2\cdot\text{OH}$

Sulphamic acid was first isolated by Berglund<sup>3</sup> in 1878 and the first convenient synthesis was due to Raschig<sup>4</sup> in 1887. It is a crystalline, non-hygroscopic solid, m.pt.  $205^\circ(\text{dec.})$  Its solubility in oxygen containing compounds is slight<sup>5</sup>, but in nitrogenous solvents<sup>5,6</sup> it is freely soluble.

Becke-Goehring<sup>7</sup> considers the acid to have the structure (8), the zwitterion form being unambiguously confirmed by both X-ray<sup>8</sup> and neutron diffraction<sup>9</sup> studies. The experimentally

determined bond lengths are  $d_{SN} = 1.74\text{\AA}$  and  $d_{SO} = 1.4\text{\AA}$ . The sulphamate ion<sup>10</sup> in which the sulphur-nitrogen distance is  $1.60\text{\AA}$  is

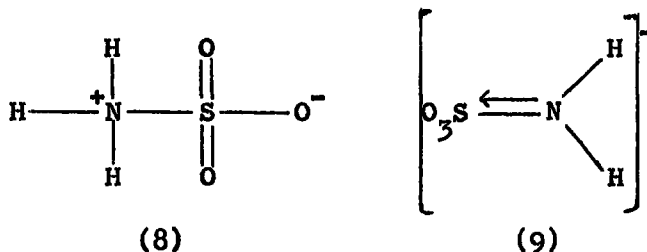

best represented by structure (9).

Four general methods<sup>2, 11</sup> may be used to prepare sulphamic acid, and all are based upon reactions which emphasise the nature of the acid as an aquo-ammonosulphuric acid.

- (i) The ammonolysis of sulphuric acid and related compounds
- (ii) The nitridation of sulphur dioxide, sulphurous acid, sulphites and hydrosulphites.
- (iii) The hydrolysis of aquo-ammonosulphuric acids
- (iv) The hydrolysis of N-acyl sulphamic acids.

Whilst the derivatives of sulphamic acid are numerous, only the action of chlorinating agents is particularly relevant to this thesis. Ephraim and Gurewitsch<sup>12</sup> studied the reaction with thionyl chloride but were unable to obtain the desired sulphamoyl chloride,  $\text{H}_2\text{N}\cdot\text{SO}_2\cdot\text{Cl}$ . These authors also reported<sup>12</sup> the formation of the addition compound,  $\text{PCl}_3\cdot\text{ClSO}_2\text{NH}_2$  from the reaction between sulphamic acid and phosphorus(V) chloride.

However, Kirsanov<sup>13</sup> has shown that this reaction gives trichlorophosphazosulphuryl chloride,  $\text{Cl}_3\text{P}=\text{N}\cdot\text{SO}_2\cdot\text{Cl}$ . This compound is very sensitive to moisture, hydrolysis giving a quantitative yield of sulphamic and phosphoric acids. The high stability of the sulphur-nitrogen bond, which is clearly greater than that of the phosphorus-nitrogen bond, is shown by this result. Thionyl chloride reacts in an analogous manner with the mercury salt<sup>14</sup> though not with the free acid; the products  $\text{OSN}\cdot\text{SO}_3\text{M}$  ( $\text{M}=\text{Na},\text{K}$ ) are stable polymeric compounds.

Sulphamoyl chloride, which cannot be prepared directly from sulphamic acid, has recently been obtained by saponification<sup>15,16</sup> of chlorsulphonyl isocyanate,  $\text{OCN}\cdot\text{SO}_2\cdot\text{Cl}$ , which is formed by reaction between cyanogen chloride and sulphur trioxide.<sup>17,18</sup> Sulphamoyl fluoride is obtained from the chloride by reaction with potassium fluoride in acetonitrile<sup>19</sup>.

Sulphamide,  $\text{SO}_2\cdot(\text{NH}_2)_2$

Sulphamide, the diamide of sulphuric acid, was first prepared<sup>20</sup> as long ago as 1838. It is, however, a difficult compound to prepare in any quantity. Virtually all of the methods which have been investigated depend upon the ammonolysis of either sulphuryl chloride or sulphuryl fluoride or chlorsulphonyl imides.

Theoretically the equation,

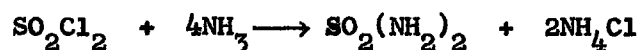

represents a possible reaction between sulphuryl chloride and ammonia. However, only small amounts of sulphamide are formed as a primary product.

Early investigators<sup>20-22</sup> reacted gaseous ammonia with an excess of sulphuryl chloride in an inert solvent. None of these workers isolated the pure compound. Ruff<sup>23</sup> reversed this procedure and, keeping ammonia in excess, isolated pure sulphamide (m.pt. 92°). This method of preparation is normally used in preference to any other,<sup>12,24-26</sup> Ephraim and Michel<sup>27</sup> and Broja<sup>28</sup> have studied the product formed when ammonia is in excess. It seems that salts of sulphimide, imidodisulphamide or long chain sulphuryl imido imides,  $H_2N.SO_2(-NH.SO_2-)_n.NH.SO_2.NH_2$ , are formed in addition to sulphamide. Chain compounds containing four  $SO_2$  groups are the most common, and the low yield of sulphamide is largely due to the fact that hydrolysis of these compounds gives only one mole of sulphamide to three of sulphamic acid. A similar situation obtains in the reaction between sulphur trioxide and ammonia<sup>29,30</sup> when only in the presence of an excess of ammonia is an appreciable yield (~10%) of sulphamide obtained. Modern theories<sup>29, 31</sup> on the formation of sulphamide suggest that in each case a condensation reaction leads to the formation of sulphamide. Thus in the case of the preparation from sulphuryl

chloride,

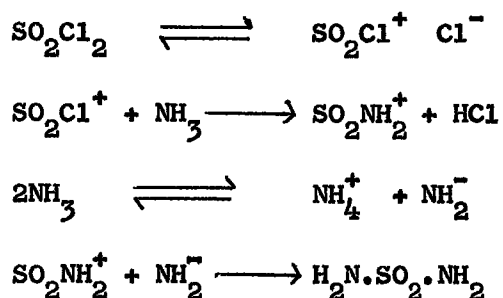

Both  $\text{SO}_3$  and  $\text{SO}_2\text{Cl}^+$ , which is isoelectronic with  $\text{SO}_3$ , are not only capable of undergoing condensation reactions but, as Lewis acids, also have a strong tendency to undergo addition reactions. Hence, it is not surprising that products other than sulphamide result from these reactions.

Sulphuryl fluoride reacts smoothly with even aqueous ammonia to give sulphamide. Wood and Battye<sup>26</sup> have stated that this route cannot be recommended because of the difficulty of handling gaseous sulphuryl fluoride and of preparing it in the pure state.

Both inorganic and organic derivatives of sulphamide are numerous, but in the main are not relevant to this thesis. The number of organic derivatives is particularly large since all four hydrogen atoms can be replaced by alkyl, aryl and acyl groups, either singly or together. The tendency of sulphamide to stabilise itself by forming a six-membered ring, as in the case of trisulphimide, is also apparent in the formation of some cyclic organic derivatives.<sup>32, 33</sup>

Sulphimide,  $\text{SO}_2\text{NH}$ , and trisulphimide,  $(\text{SO}_2\text{NH})_3$

Various sulphur imides based on sulphur trioxide are possible, assuming that one or more oxygen atoms can be replaced by the isoelectronic NH group. Traube<sup>21</sup> examined the effect of heat on sulphamide and, though unable to obtain a free imide, prepared what he believed to be salts of sulphimide,  $\text{SO}_2\text{NH}$ . Hantzsch and Holl<sup>34</sup> concluded that these compounds were derived from the cyclic trisulphimide,  $(\text{SO}_2\text{NH})_3$ . The free imide reported by these authors has been shown<sup>35</sup> to be imidodisulphamide. More recently several workers<sup>36-38</sup> have re-examined the action of heat on sulphamide. Ito<sup>38</sup> has studied the reaction in some detail. It appears that sulphamide is stable up to  $120^\circ\text{C}$ , but at temperatures above this two reactions may occur,

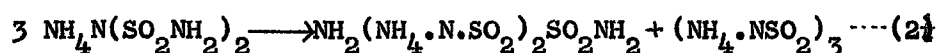
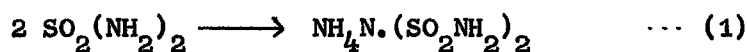

The main product at temperatures of  $< 170^\circ\text{C}$  is  $\text{NH}_4\text{N} \cdot (\text{SO}_2\text{NH}_2)_2$ . Yields from reaction (2) increase at higher temperatures and prolonged heating at  $200^\circ\text{C}$  causes complete conversion to the ammonium salt. Metal salts of trisulphimide are readily prepared<sup>36</sup> from the ammonium compound. The silver salt with methyl iodide yields the trimethyl compound,  $(\text{SO}_2\text{N} \cdot \text{CH}_3)_3$ , which molecular weight determinations show to be a trimer.

From an examination<sup>39</sup> of the silver salt it appears that the anion is a planar six-membered ring of alternating sulphur and nitrogen atoms.

Attempts to prepare the free trisulphimide have failed. Heinze and Meuwsen<sup>36</sup> decomposed the silver salt with an equivalent quantity of hydrochloric acid and showed that a tribasic acid resulted. This acid readily lost two protons, though the third proton could be removed only with difficulty, hence the ion (10)

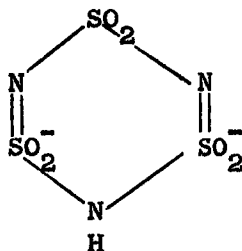

(10)

has a high stability. The dipyrnidinium salt of trisulphimide, which is derived from this ion, can also be obtained<sup>40</sup> by reaction of sulphamoyl chloride with pyridine.

Appel and Becke-Goehring<sup>41</sup> have attempted a direct synthesis of sulphimide by reacting ammonia with excess sulphur trioxide in nitromethane. The main product was  $(\text{NH}_4)_2\text{S}_3\text{O}_{10}$ ; the small amount of water soluble substance,  $(\text{HNSO}_2)_n \cdot \text{H}_2\text{SO}_4$ , also present was shown to be a polysulphimide sulphonic acid<sup>42</sup>.



Tetrasulphur tetranitride and the cyclic and acyclic sulphur-nitrogen halides and oxo-halides

These compounds are of considerable chemical interest. Not only do they exhibit some remarkable chemical properties but, from the theoretical standpoint, they raise some interesting questions as to chemical bonding. They also represent the first examples known so far in pure inorganic chemistry where single, double and triple bonds as well as localised and delocalised double bonds occur. Rings containing delocalised double bonds may be regarded as inorganic aromatic compounds, analogous to the better known phosphonitrilic compounds. Several reviews concerning some or all of these compounds have been published.<sup>7, 43-45</sup> The most important of these compounds and one which may be considered the parent of many of the others is tetrasulphur tetranitride.

Tetrasulphur tetranitride, S<sub>4</sub>N<sub>4</sub>

Tetrasulphur tetranitride was first prepared<sup>46,47</sup> in 1835 as one of the products of the reaction between sulphur monochloride and ammonia. However, it was not until 1850 that the composition of the compound was determined<sup>48</sup>, and not until 1896 that molecular weight determinations<sup>49, 50</sup> gave the formula S<sub>4</sub>N<sub>4</sub>. Tetrasulphur tetranitride is a solid at room temperature. It forms orange-yellow crystals<sup>51</sup> of the class D<sub>2d</sub> and space group C<sub>2h</sub><sup>5</sup>. It is

diamagnetic and strongly exothermic. The pure compound has m.pt.  $192^{\circ}\text{C}$ , but impure specimens have been reported to explode when heated at  $>100^{\circ}\text{C}$ .

Whilst tetrasulphur tetranitride can be prepared in low yield by several methods<sup>52-57</sup>, the only convenient preparation is from the complex reaction between sulphur chlorides and ammonia. Whilst sulphur monochloride alone may be used as the starting material<sup>53, 58, 59</sup> better yields are obtained from the dichloride.<sup>48, 50, 60</sup> The accepted method of preparation<sup>43, 61, 62</sup> involves the preparation of the dichloride in situ from the reaction between the monochloride and chlorine,

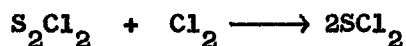

The subsequent reaction with ammonia may be represented as,

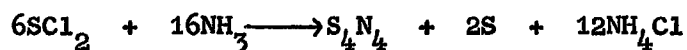

The actual course of the reaction is not yet understood, besides tetrasulphur tetranitride, sulphimide, heptasulphur imide, sulphur and ammonium chloride are formed.

The chemical and physical properties of tetrasulphur tetranitride show it to contain delocalised  $p_{\pi}$  (nitrogen)- $d_{\pi}$  (sulphur) bonds, i.e. it is an inorganic, aromatic compound. Chemical investigations<sup>53, 63-65</sup> show all of the sulphur to be present in the sulphur (III) state, e.g. in weakly alkaline solution<sup>63</sup>

hydrolysis occurs according to the equation,

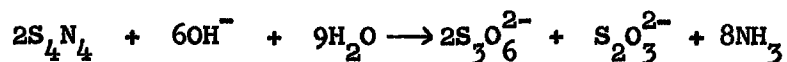

and in strongly alkaline solution,<sup>65</sup>

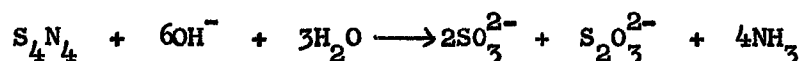

These results eliminate the possibility that tetrasulphur tetranitride is a nitrite of dithionous acid.<sup>63</sup> The equivalence of sulphur atoms in tetrasulphur tetranitride has also been shown by labelling techniques<sup>66</sup> and by a study of the  $K_{\alpha}$  X-ray emission spectrum.<sup>67</sup> Reduction<sup>65, 68, 69</sup> leads to tetrasulphur tetraimide,  $S_4(NH)_4$ , which has been shown by chemical<sup>70</sup> and physical<sup>71</sup> methods to have structure (11).

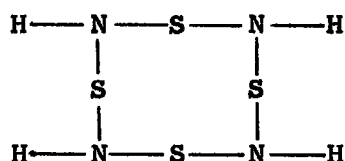

(11)

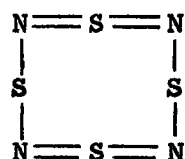

(12)

Since the tetraimide is readily reoxidised<sup>69</sup> to the tetranitride it is reasonable to postulate some such structure as (12) for the tetranitride. That is, a structure containing an eight-membered ring of alternating sulphur and nitrogen atoms. The equivalence of the sulphur atoms is explained<sup>43, 44</sup> by resonance

between such limiting forms as (13a-13d).

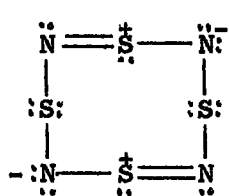

(13a)

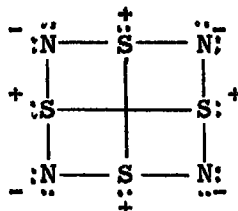

(13b)

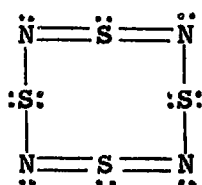

(13c)

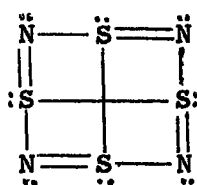

(13d)

Structural determinations<sup>51, 72, 73</sup> support these suggestions.

The molecule has the structure shown in Fig.2. The sulphur-

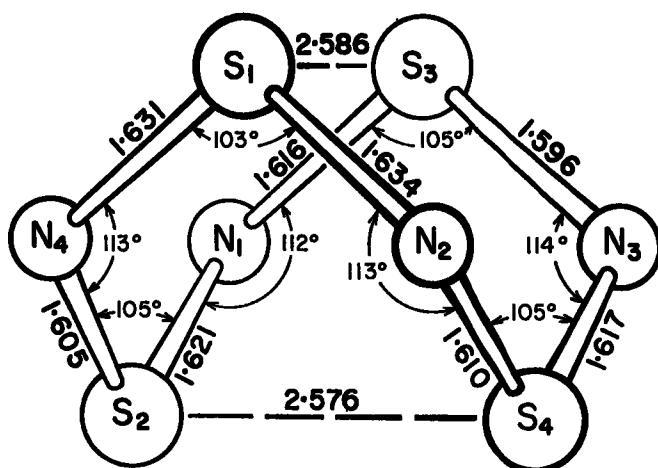

Fig.2.  
The structure of tetrasulphur tetranitride<sup>73</sup>

nitrogen bond lengths are all equal, and the average value<sup>73</sup> ( $1.616 \pm 0.010\text{\AA}$ ) implies a considerable amount of double bond character<sup>44,73</sup>. On the other hand,<sup>73</sup> the angles at sulphur ( $\widehat{NSN} = 105^\circ$ ) and nitrogen ( $\widehat{SNS} = 113^\circ$ ) do not imply much, if any, double bond character. This apparent paradox is not resolved by a consideration of the most important resonance forms (13a-13d). Donohue and Sharma<sup>73</sup> suggest that the geometrical restraints of the molecular symmetry may result in some strain, which could also account for the instability of the molecule. The distance ( $2.58\text{\AA}$ ) between two sulphur atoms not linked by nitrogen is shorter than the sum of the van der Waal's radii ( $3.3\text{\AA}$ ) and rather longer than a sulphur-sulphur single bond ( $2.05\text{\AA}$ ). Hence, there must be some interaction between the sulphur atoms, and Lindquist<sup>74</sup> has postulated a p-bond. Donohue and Sharma<sup>73</sup> consider that this suggestion leaves unexplained the short sulphur-nitrogen bond length.

Several theoretical treatments of the bonding in tetrasulphur tetranitride are reported. Craig et.al.<sup>75</sup> consider delocalised  $\pi$ -bonds, resulting from  $p_\pi$  (nitrogen)- $d_\pi$  (sulphur) overlap, to be of some importance. This suggestion is supported by measurements of the electron spin resonance of sulphur nitride ions.<sup>76</sup> On the other hand, Dewar et.al.<sup>77</sup> conceive the  $\pi$ -bonds as three-centre bonds, each involving a central nitrogen atom and two adjacent

containing the metal in a higher oxidation state (Tl(III), Ag(II), Cu(II)) may be obtained. Metal thionitrosylates are also readily obtained from tetrasulphur tetraimide.<sup>86,87</sup> In these reactions, in contrast to those with the tetranitride, the metal does not change its oxidation state. Very stable compounds are obtained by reaction of tetrasulphur tetranitride with some transition metal derivatives;<sup>88,89</sup> compounds isolated to date have  $M = \text{Ni, Pt, Pd, Co and Fe}$ . These compounds were initially formulated as  $M(\text{NS})_4$ , but have since been shown<sup>90,91</sup> to contain hydrogen, and should be written as  $M(\text{S}_2\text{N}_2\text{H})_2$ . The magnetic properties are reported<sup>92-94</sup> and structural studies<sup>95</sup> show that these compounds contain the  $\text{S}_2\text{N}_2\text{H}$  ligand. Various other metal derivatives are known, and the field has been recently reviewed<sup>96</sup>. Tetrasulphur tetranitride also forms adducts with metal salts in inert solvents.<sup>96-101</sup> A series of novel metal derivatives has recently been prepared by dissolution of these adducts in thionyl chloride<sup>102</sup>.

The cyclic sulphur-nitrogen halides and oxhalides

Tetrathiazyl tetrafluoride.  $\text{S}_4\text{N}_4\text{F}_4$

The ring system of tetrasulphur tetranitride remains intact on cautious fluorination with silver fluoride<sup>103</sup>, which gives tetrathiazyl tetrafluoride. Alkali hydrolysis of  $\text{S}_4\text{N}_4\text{F}_4$  gives ammonium fluoride and sulphurous acid, which suggests that the

sulphur has an average oxidation number of 4, and that the fluorines are attached to sulphur. The nuclear magnetic resonance spectrum<sup>104</sup> shows that the molecule is symmetrical, that all the fluorine atoms are structurally equivalent and that the fluorine atoms are attached to sulphur. Structural investigations<sup>103, 105</sup> confirm these suggestions. The molecule consists of a puckered eight-membered ring (Fig.3) the form of which is quite different from that of tetrasulphur

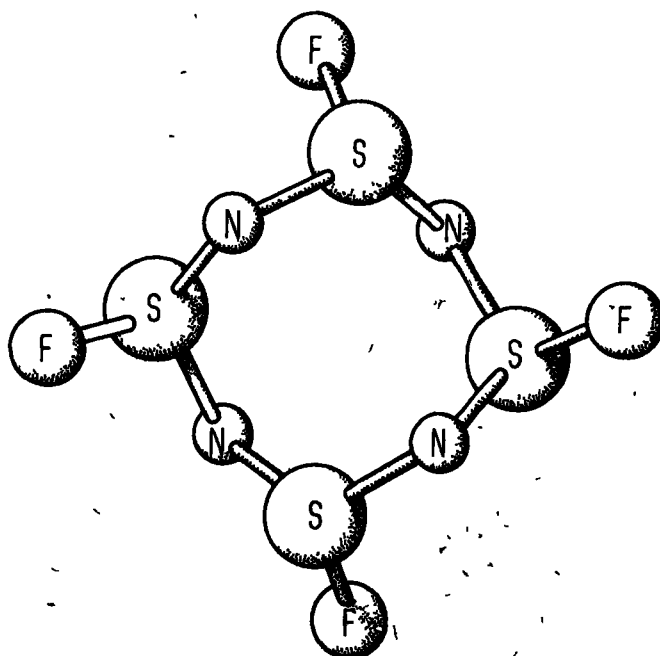

Fig.3.  
The structure of  $N_4S_4F_4$

tetranitride. Two sulphur-nitrogen bond lengths, 1.66 and 1.54 Å are observed. These bond distances correspond<sup>44</sup> to bond orders of 1.4 and 2.0 respectively, so that, in contrast to  $S_4N_4$ , essentially localised bonds are present in the molecule.

Tetrathiazyl tetrafluoride functions as a Lewis base; thus the unstable adduct,  $N_4S_4F_4BF_3$  is reported<sup>106</sup>. Thermal decomposition<sup>107</sup> of the tetrafluoride gives the unstable thiazyl fluoride, NSF.

Trithiazyl trifluoride  $N_3S_3F_3$

Trithiazyl trichloride,  $N_3S_3Cl_3$ , reacts<sup>108</sup> with silver difluoride to give trithiazyl trifluoride. The compound decomposes in moist air, and is quantitatively hydrolysed<sup>108, 109</sup> by dilute alkali according to the equation,



in which respect it behaves analogously to  $N_3S_3Cl_3$ . The mechanism of the hydrolysis of these two compounds has been studied in detail,<sup>44, 107</sup> and appears to proceed via nucleophilic attack of  $OH^-$  ion on the sulphur atom, with consequent rupture of the ring. The validity of the proposed mechanism has been tested<sup>107</sup> using nucleophiles other than  $OH^-$  and the expected products<sup>109, 110</sup> were obtained. By analogy with the trichloride (see text) the trifluoride is thought to contain a cyclic six-



membered ring. The nuclear magnetic resonance spectrum<sup>104</sup> shows all the fluorine atoms to be equivalent, and its similarity to that of  $N_4S_4F_4$  suggests that localised double and single bonds are present in the molecule.

Trithiazyl trichloride,  $N_3S_3Cl_3$

Whilst on careful fluorination of tetrasulphur tetranitride the eight membered ring remains intact, chlorination<sup>108, 111</sup> leads to ring contraction with the formation of  $N_3S_3Cl_3$ . The structure of this compound has been accurately determined<sup>112</sup>. The molecule has only one direct sulphur-nitrogen distance,  $1.605 \pm 0.005 \text{ \AA}$ , which indicates<sup>44, 107b</sup> delocalisation of the  $\pi$ -bonds and, therefore, an inorganic aromatic ring. The six-membered ring is in the chair form; the nitrogen atoms deviate by an average of  $0.18 \text{ \AA}$  from the plane of the sulphur atoms, and the chlorine atoms, all pointing in one direction, are located in axial positions (Fig.4)

The hydrolysis of the trichloride has already been discussed (above); further evidence that the sulphur is present in the sulphur(IV) state is provided by the reaction with hydrochloric acid<sup>113</sup> which liberates all the sulphur as sulphur dioxide.

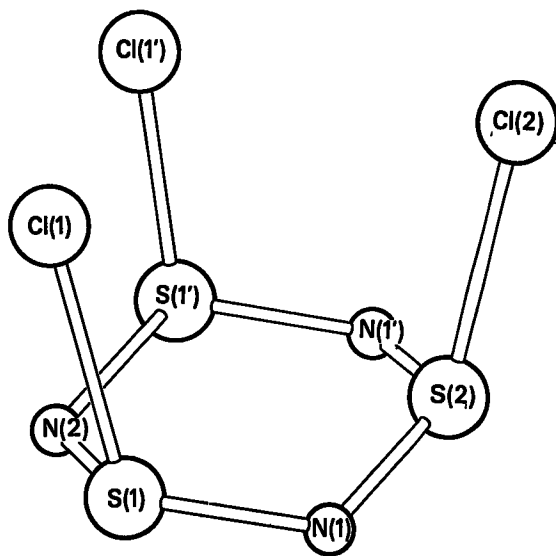
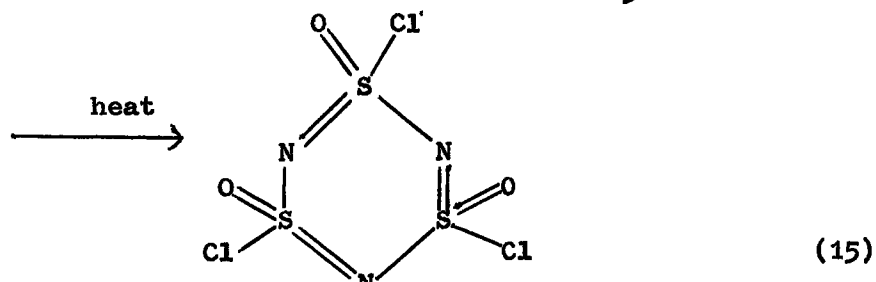
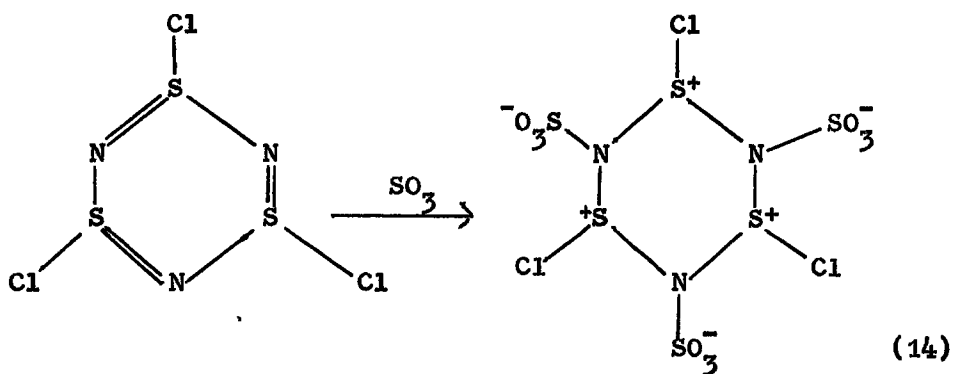
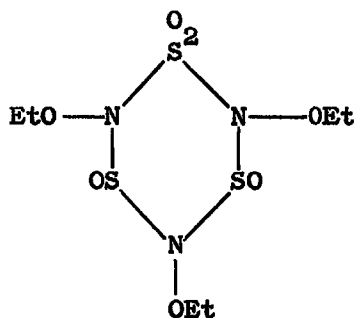

Fig. 4.  
The structure of  $(NSCl)_3$

Trithiazyl trichloride undergoes reactions in which the six-membered ring remains intact as well as reactions in which it is destroyed. Reaction with sulphur trioxide<sup>114</sup> gives the adduct (14) which on heating gives sulphanuric chloride (15).



The ring system is also maintained on reaction with ethyl hypochlorite<sup>113</sup> when the compound (16) is obtained



(16)

Other oxidants cause ring breakdown. Nitrogen dioxide<sup>113</sup> gives a compound,  $(\text{NO})_2\text{S}_2\text{O}_7$ , as it does with tetrasulphur tetranitride<sup>115</sup>, but nitric oxide gives  $\text{S}_3\text{N}_2\text{Cl}$ .

Ammonolysis<sup>43</sup> also destroys the ring system. A red substance is formed which with mercuric iodide gives  $\text{Hg}(\text{N}_2\text{S})$ , which may also be prepared<sup>83</sup> from  $\text{S}_2\text{N}_2 \cdot \text{NH}_3$ . Thus, trithiazyl trichloride can function as a starting material for the preparation of derivatives of the imide of orthosulphurous acid,  $\text{S}_2(\text{NH})_2$ . Whilst this imide has not yet been prepared in a pure state its potassium salt<sup>83</sup>,  $\text{K}_2(\text{N}_2\text{S})$ , and a butyl derivative<sup>116</sup>,  $\text{S}(\text{N}_2\text{C}_4\text{H}_9)_2$ , are known.

Reduction of  $\text{N}_3\text{S}_3\text{Cl}_3$  with tetrasulphur tetraimide<sup>114</sup>, or heptasulphur imide in the presence of pyridine<sup>44</sup>, gives  $\text{S}_4\text{N}_4$ .

In the absence of pyridine<sup>117</sup> a brown-red adduct,  $S_4N_4 \cdot 4HCl$  is formed which reacts with traces of water to give  $S_4N_3Cl$ .

Sulphanuric chloride  $N_3S_3O_3Cl_3$

Sulphanuric chloride was first prepared by Kirsanov<sup>13, 118</sup> by reaction of sulphamic acid with phosphorus pentachloride and thermal decomposition of the product.

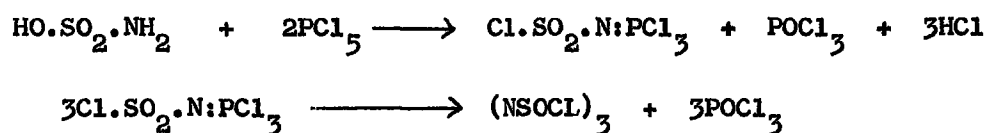

The decomposition reaction is considerably more complex than this simple equation suggests. The isomeric  $\alpha$ - and  $\beta$ -sulphanuric chlorides are fairly easily obtained from the crude pyrolysis product, the  $\alpha$ -isomer being formed in the greater yield. However, Kirsanov<sup>118</sup> also reported the presence in the crude product of at least three other compounds, none of which have been characterised.

Whilst the Kirsanov method is the most convenient route to sulphanuric chloride it may also be prepared in other ways. The decomposition of a mixture of thionyl and sulphuryl chlorides with ammonia<sup>119</sup> gives sulphanuric chloride in low yield, as does the oxidation<sup>114</sup> of trithiazyl trichloride with sulphur trioxide. Vandl, Moeller and Brown<sup>120</sup> have reported a modification of the Kirsanov procedure which differs from the original method in the

mode of treatment of the crude pyrolysis product. Grampel and Vos<sup>121</sup> were unable to obtain sulphanuric chloride in the manner reported by Kirsanov<sup>118</sup>; they reported that pyrolysis of the intermediate,  $\text{ClSO}_2\cdot\text{N}\cdot\text{PCl}_3$ , in the presence of ultra-violet radiation gave a compound (17)

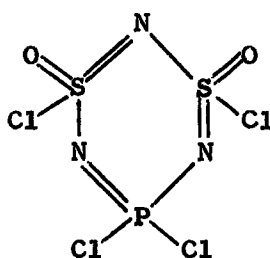

(17)

The significance of this observation is not clear. The author has prepared sulphanuric chloride by the Kirsanov method on several occasions, as have Banister<sup>122</sup> and Vandi et.al.<sup>120</sup> It is possible that the compound reported by Grampel and Vos<sup>121</sup> resulted from the use of ultra-violet radiation.

Sulphanuric acid,  $(\text{NSO}\cdot\text{OH})_3$  should be the first product of the hydrolysis of sulphanuric chloride. Like trisulphimide, with which it is isomeric, the acid is not known as such and is clearly very unstable. Even on careful acid hydrolysis,<sup>123</sup> imidodisulphamide and sulphuric acid are formed immediately. On the other hand, trisulphimide <sup>in</sup> an acid medium gives sulphamide,

and sulphamic and sulphuric acids. The difference in the hydrolysis products from two such similar compounds is striking.

Whilst sulphauric chloride is hydrolysed by moist air the corresponding fluoride is particularly stable. Two isomeric fluorides have been reported by Seel and Simon<sup>124</sup> who caused  $\alpha$ -sulphauric chloride to react with potassium fluoride in carbon tetrachloride at 145°C. Moeller and Ouchi<sup>125</sup> have reported an alternative synthesis using potassium fluoride in acetonitrile.

Sulphauric chloride undergoes solvolytic substitution reactions only under carefully controlled conditions, in which respect it seems to resemble the somewhat analogous trithiazyl trichloride<sup>123</sup>. Reaction with ammonia results in solvolysis followed by polymerisation<sup>126</sup> to give melam and melem analogues, and with morpholine<sup>120</sup>, at room temperature, N-N' dimorpholido sulphamide is formed. Under controlled conditions at low temperature simple metathesis reactions may be affected; e.g. Failli et.al.<sup>127</sup> have prepared two isomeric trimorpholido derivatives. It appears that by varying the solvent used one or other isomer may be made to predominate.

Sulphauric fluoride<sup>125</sup> is reported to be more stable with respect to ring cleavage than sulphauric chloride, and it more readily undergoes substitution reactions. Reaction with phenyl

lithium in diethyl ether in the corresponding mole ratios yields the mono- and diphenyl derivatives, both of which are obtained in only one isomeric form. The triphenyl compound cannot be prepared in this manner but may be prepared by reaction of the fluoride in benzene with aluminium chloride. The secondary amines, morpholine, 2,6 dimethylmorpholine, piperidine and pyrrolidine form disubstituted products, irrespective of the mole ratios used, each in two isomeric forms.

The structure of  $\alpha$ -sulphanuric chloride has been determined by X-ray crystallography.<sup>127-130</sup> The molecule exists as a ring in the chair form; the nitrogen atoms deviate by an average of  $\sim 0.25\text{\AA}$  from the plane of the sulphur atoms. The chlorine atoms are all located on one side of the molecule in axial positions; the oxygen atoms are all in equatorial positions. Fig.5 shows the structure of  $\alpha$ -sulphanuric chloride;  $\text{S}_3\text{O}_9$  which is isoelectronic with  $(\text{NSOCl})_3$  has a similar structure.

The S-N bond lengths are all equal<sup>130</sup> at  $1.571 \pm 0.004\text{\AA}$ ; which is most simply explained as a result of delocalised  $p_\pi - d_\pi$  bonding<sup>44, 130</sup>. Veigers and Vos<sup>131</sup> have shown that this equality of bond lengths is probably genuine and not

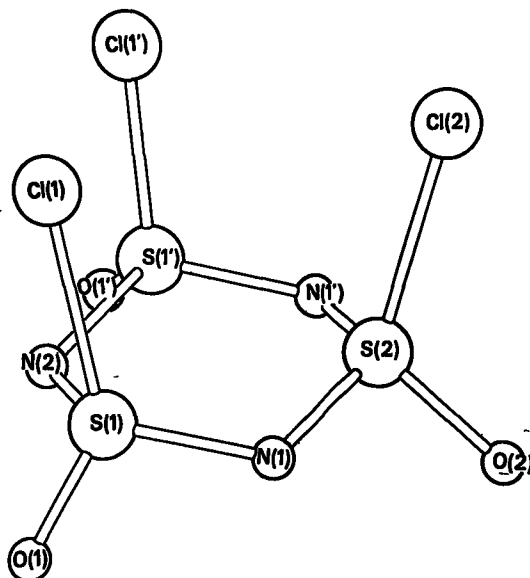

Fig.5.  
The structure of  $\alpha$ -(NSOCl)<sub>3</sub>

merely the result of refining in the wrong space group. The sulphur atoms have coordination number 4, the bonds pointing to the corners of a tetrahedron. The angles  $\hat{N}SN(113^\circ)$  and  $\hat{O}SCl(107^\circ)$  are more nearly equal than is the case in the phosphonitrilics<sup>132</sup>. Hazell *et.al.*<sup>130</sup> consider that the small difference between the endo-and exocyclic angles in  $\alpha$ -(NSOCl)<sub>3</sub> may be due to the double bond character of the S=O exocyclic bond.  $\alpha$ -Sulphanuric chloride is obtained as the major product from the Kirsanov preparation and yet of the four possible isomers it is the one showing maximum steric repulsion between ring substituents.



This situation may be compared with that in  $(NSF)_4$  and  $(NSCl)_3$ ; in all three compounds the strongly repelling groups (the lone pair electrons in the sulphur(IV) compounds or the double bond to oxygen in  $\alpha$ - $(NSOCl)_3$ ) are pointing away from the mean plane of the ring. A number of factors may be responsible but two important ones may be (i) the repelling effect of axial sulphur lone pair electrons or axial S=O bonds exceeds that of an axial S-Cl bond, (ii) that these structures result in the closest packing in the solid state or maximum intermolecular attractions. If this latter reason is important then these molecules may have different structures in solution than in the solid phase. A similar situation occurs with the tetrameric phosphonitrilic chloride and fluoride.<sup>133</sup>

Definite structural data on other sulphanic compounds is lacking. The dipole moment studies of Vandi et.al.<sup>120</sup> suggest that in  $\beta$ - $(NSOCl)_3$  the ring has the chair form present in the  $\alpha$ -isomer. In their calculations these authors made no allowance for the atom polarisations of the molecules. Rogers and Gross<sup>134</sup> have determined the dipole moments of both sulphur and tetrasulphur tetranitride in benzene. They concluded that for  $S_4N_4$  the moment observed (0.52D) when atom polarisation is neglected is due to entirely an abnormally large atom refraction. On the other hand  $(NSF)_4$  - which contains localised

bonds - has a zero dipole moment as expected.

The infrared spectra<sup>125, 127</sup> of the isomeric aryl and diarylamino-sulphanuric compounds suggest that the isomerism arises from differences in the orientation of the substituents, as in the chlorides, rather than from differences in the conformation of the ring itself.

Thiotriothiazyl compounds.  $S_4N_3X$

The most stable compounds derived from  $S_4N_4$  are the thiotriothiazyl compounds,<sup>135-137</sup>  $(S_4N_3)X$ , where X may be, e.g., halogen  $HSO_4^-$ ,  $NO_3^-$ ,  $SCN^-$ ,  $BPh_4^-$ ,  $SbCl_6^-$  or  $SbCl_4^-$ . The best known of these compounds is the chloride which is obtained from  $S_4N_4$  by reaction with various non-metal halides,<sup>117, 138-143</sup> e.g.,

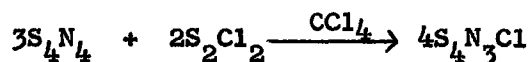

MacDiarmid<sup>117, 138</sup> believes that these reactions involve the formation of hydrogen chloride, which then reacts with the  $S_4N_4$ . Becke-Goehring<sup>144</sup> has shown that the reaction with sulphur monochloride must proceed via several intermediates since, depending upon the concentration of  $S_2Cl_2$ , varying amounts of  $^{35}S$  can be introduced into the  $S_4N_3Cl$ . The compound  $S_3N_2Cl$  is possibly one such intermediate; it is obtained in the cold from  $S_4N_4$  and  $S_2Cl_2$ , and decomposes on heating in carbon tetrachloride.

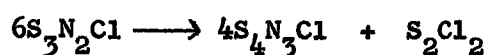

$\text{S}_4\text{N}_3\text{Cl}$  can also be prepared by the reaction<sup>145</sup> between  $\text{S}_2\text{Cl}_2$  and  $\text{NH}_3$  in carbon disulphide, and by treatment<sup>146</sup> of  $\text{S}_2\text{Cl}_2$  with lithium azide. All other known sulphur-nitrogen chlorides can be converted<sup>44</sup> into  $\text{S}_4\text{N}_3\text{Cl}$ , e.g.  $\text{N}_3\text{S}_3\text{Cl}_3$  and  $\text{S}_3\text{N}_2\text{Cl}_2$  by heating with  $\text{S}_2\text{Cl}_2$  in  $\text{CCl}_4$ , or  $\text{S}_3\text{N}_3\text{Cl}$  by reaction with  $\text{S}_2\text{Cl}_2$  in the presence of chlorine and carbon tetrachloride.

$\text{S}_4\text{N}_3\text{Cl}$  is stable in dry air. In vacuo at  $170^\circ$  it decomposes to give  $\text{S}_4\text{N}_4$ . Hydrolysis<sup>141</sup>, depending upon the conditions, gives rise to the black, probably polymeric, compounds  $\text{S}_4\text{N}_3\text{OH}$  and  $(\text{S}_3\text{N}_3\text{OH})_2$  ~~are formed~~. Both hydroxides are unstable and give  $\text{S}_4\text{N}_4$  on standing. With sulphur trioxide<sup>147</sup> the adduct  $\text{S}_4\text{N}_3\text{Cl} \cdot 2\text{SO}_3$  results. Reaction with metal azides<sup>148</sup> gives  $\text{S}_4\text{N}_4$ .

The average oxidation number of the sulphur in  $\text{S}_4\text{N}_3\text{Cl}$  is 2.5 as is shown by reaction<sup>149</sup> with piperidine. The ready exchange that the chlorine of  $\text{S}_4\text{N}_3\text{Cl}$  undergoes with anionic radicals,<sup>135-137</sup> indicated a salt-like structure,  $(\text{S}_4\text{N}_3)^+\text{X}^-$ . Molecular weight determinations<sup>137, 150</sup> verified this suggestion and showed that  $(\text{S}_4\text{N}_3)^+$  cation to be monomeric in solution. The structure<sup>151</sup> of the cation has been fully worked out from a study of the nitrate, and is shown in Fig.6. The molecule is planar in

contrast to the markedly puckered, or non-planar rings of the parent compound  $S_4N_4$  and the other six- and eight-membered sulphur-nitrogen rings prepared from  $S_4N_4$ , i.e.,  $S_4N_4H_4$ ,  $S_4N_4F_4$ ,  $S_3N_3Cl_3$  and  $S_3N_3O_3Cl_3$ . The average S-N bond distance,  $1.54 \pm 0.04 \text{ \AA}$  corresponds to a double bond. This high bond order all around a planar system suggests a well developed  $\pi$ -electron system. Studies of the electronic spectrum<sup>152</sup> support this and are best explained on the basis of a ten electron  $\pi$ -system delocalised over all of the S-N linkages. This hypothesis requires the participation of sulphur d-orbitals in the  $\pi$ -bonding.

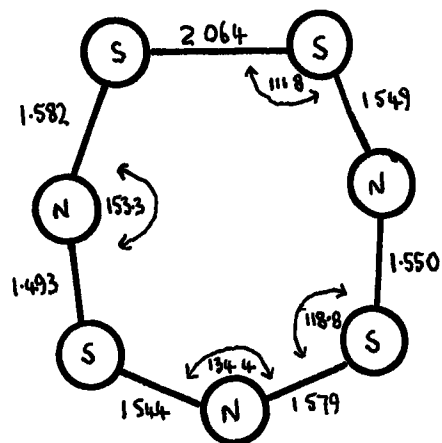

Fig. 6.  
The structure of the  $S_4N_3^+$  cation

The acyclic sulphur-nitrogen halides

Thiazyl fluoride NSF.

Thiazyl fluoride, an unstable gas, is prepared by the fluorination of  $S_{\frac{1}{2}}N_{\frac{1}{2}}$  with mercury<sup>153</sup> silver<sup>153</sup> or cobalt<sup>154</sup> fluorides, or by reaction between ammonia and sulphur tetrafluoride.<sup>155</sup> The structure of NSF has been determined by infrared<sup>104</sup>, nuclear magnetic resonance<sup>104</sup> and microwave<sup>156</sup> spectroscopy, and by electron diffraction,<sup>157,158</sup> and is as shown in Fig.7(a).

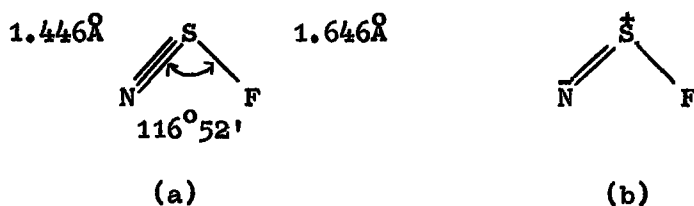

Fig.7.  
The structure of thiazyl fluoride

The SN force constant derived from the infrared spectrum corresponds<sup>104,159</sup> to a bond order of 2.3; the SN bond length being 1.446 Å. The mesomeric structure (b) contributes<sup>44</sup> to an SN bond order of greater than 2.

Aqueous hydrolysis gives monomeric thionyl imide<sup>160</sup>,  $HNSO$ , as an intermediate and, finally,  $SO_3^{2-}$ ,  $F^-$  and  $NH_4^+$ . Alkaline hydrolysis proceeds similarly though the products are not obtained in quantitative yield.

In glass vessels at room temperature and at pressures of < 760mm.Hg. NSF decomposes to give  $S_3N_2F_2$ . At higher temperatures reaction with the glass is rapid and gives  $S_4N_4$ ,  $SOF_2$ ,  $SO_2$ ,  $SiF_4$  and  $N_2$ . Chlorination<sup>161</sup> of NSF gives monomeric NSCl. With boron trifluoride the adduct,  $FSN.BF_3$  is thought to be formed<sup>162</sup>, but is so unstable that it is not well characterised.

Thiazyl chloride. NSCl

The gaseous unstable NSCl may be prepared by the thermal decomposition<sup>163</sup> of  $(NSCl)_3$  in vacuo, or by the reaction between ammonium chloride and excess sulphur chloride.<sup>164,165</sup> The infrared spectrum is similar to that of NSF so that both gases must have similar structures<sup>161</sup>. The thionitrosyl halides S=N-F and S=N-Cl which are isomeric with the thiazyl halides are still unknown.

Thiazyl trifluoride  $NSF_3$

Thiazyl trifluoride may be prepared by the fluorination of NSF with silver difluoride<sup>44</sup> or by fluorination of  $S_4N_4$  with a mixture of silver difluoride and cobalt trifluoride<sup>154</sup>. This latter reaction is complex; besides  $NSF_3$  and NSF, at least ten other volatile compounds are formed.  $NSF_3$  is also obtained<sup>44</sup> in low yields when ammonia is introduced into a mixture of sulphur

and  $\text{AgF}_2$  in  $\text{CCl}_4$ . Good yields of  $\text{NSF}_3$  are reported<sup>168</sup> from the reaction between  $\text{S}_2\text{F}_{10}$  and ammonia.

Thiazyl trifluoride is a colourless gas which in contrast to  $\text{NSF}$  is extremely stable. Metallic sodium reacts only on heating to  $400^\circ\text{C}$ ; no reaction occurs with gaseous ammonia at room temperature and  $\text{NSF}_3$  is not attacked by dilute acids. Thiazyl trifluoride reacts<sup>162</sup> with  $\text{BF}_3$  to form the compound,  $\text{F}_3\text{SN}\cdot\text{BF}_3$ , which in the liquid phase appears to have structure (18a); in the solid state a fluoroboronium compound (18b) may be present<sup>169</sup>. The instability of  $\text{F}_3\text{SN}\cdot\text{BF}_3$  indicates that the donor activity of the nitrogen lone pair is weakened by the inductive effect of the fluorine atoms attached to the sulphur.

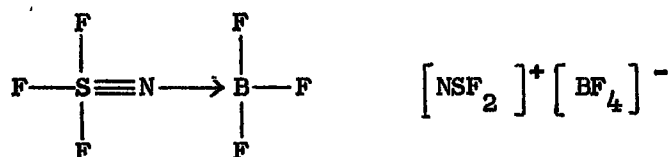

(18a)

(18b)

From a study of the infrared and nuclear magnetic resonance spectra of  $\text{NSF}_3$ , Richert and Glemser<sup>104</sup> have shown the molecule to have a tetrahedral structure of  $\text{C}_{3v}$  symmetry, with all of the fluorine atoms attached to sulphur in structurally equivalent positions. The infrared spectrum has great similarity<sup>170</sup> to that of the tetrahedral compound  $\text{OPF}_3$ . The spectroscopic study<sup>104</sup> suggests a sulphur-nitrogen bond order of 2.7. Microwave

studies<sup>156</sup> confirm these results, the very short sulphur-nitrogen bond distance of  $1.416\text{\AA}$  corresponding<sup>44</sup> to a bond order of  $\sim 3.0$ . The structure of  $\text{NSF}_3$  is shown in Fig.8.

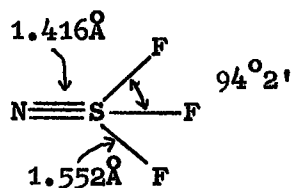

Fig.8.  
The structure of  $\text{NSF}_3$ .

Thiazyl trifluoride is the first compound to contain a sulphur-nitrogen triple bond and may be regarded as derived from the stable  $\text{SF}_6$  by substitution of a nitrogen atom for three fluorine atoms. Whilst in  $\text{SF}_6$  the sulphur atom exhibits  $sp^3d^2$  (octahedral) hybridisation, in  $\text{NSF}_3$ ,  $sp^3$  (tetrahedral) hybridisation occurs. In addition two  $p_\pi-d_\pi$  bonds are formed<sup>44</sup> between the nitrogen and the sulphur atoms.

#### Thiazyl bromide. NSBr

Bromine reacts<sup>166</sup> with  $\text{S}_4\text{N}_4$  in carbon disulphide to give the bronze coloured compound,  $(\text{NSBr})_n$ . The molecular weight of this compound is unknown. With acetyl bromide<sup>167</sup>  $\text{S}_4\text{N}_4$  reacts to give  $\text{S}_2\text{N}_3\text{HBr}_4$ .

#### Thiodithiazyl difluoride, $\text{S}_3\text{N}_2\text{F}_2$

Thiodithiazyl difluoride is formed<sup>171</sup> in low yield when  $\text{NSF}_3$



is decomposed in a glass vessel. The crude product appears to contain two polymorphic forms of the compound  $S_3N_2F_2$  for which if, covalent, two structures, (19a) and (19b) may be postulated.

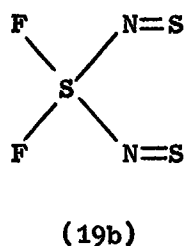
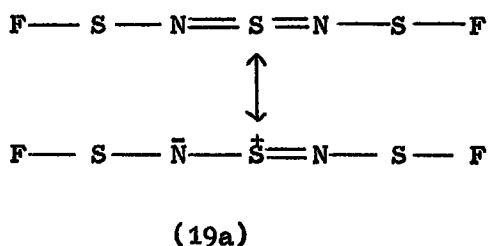

Glemser<sup>44</sup> prefers (19a) on the grounds that the intense colour of the fluoride requires a structure in which resonance is possible.

Thiodithiazyl dichloride.  $S_3N_2Cl_2$

Thiodithiazyl dichloride may be prepared<sup>172</sup> by gently heating  $(NSCl)_3$  in  $S_2Cl_2$ . In the presence of excess chlorine it reverts to  $(NSCl)_3$ ; possibly in accordance with the equation,<sup>172</sup>



Further heating in  $S_2Cl_2$ <sup>139</sup> or  $S_2Cl_2$  in  $CCl_4$ <sup>44</sup> or in  $CCl_4$ <sup>165</sup> gives  $S_4N_3Cl$ , probably<sup>165</sup> via  $S_3N_2Cl$ . Jolly *et.al.*<sup>165</sup> have reported a more convenient synthesis from ammonium chloride and

$S_2Cl_2$  and have suggested the mechanism,

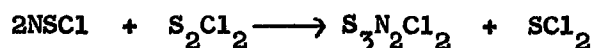
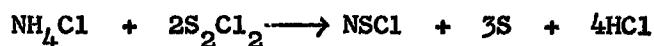

The structure of  $S_3N_2Cl_2$  has recently been determined<sup>173</sup> and is shown in Fig.9. The ring is slightly puckered

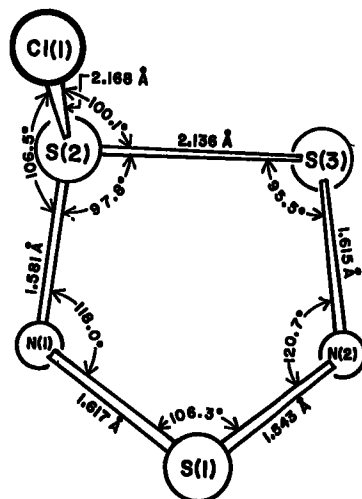

Fig.9.  
The structure of  $S_3N_2Cl_2$ <sup>173</sup>

The properties and reactions of  $S_3N_2Cl_2$  have been the subject of a recent investigation<sup>174</sup>.

Thiodithiazyl chloride.  $S_3N_2Cl$

Green crystalline  $S_3N_2Cl$  may be obtained<sup>175</sup> from  $S_4N_4$  and  $S_2Cl_2$  in the cold, or by vacuum sublimation<sup>165</sup> of  $S_3N_2Cl_2$ . It is also formed<sup>144</sup> when  $NOCl$  reacts with  $S_4N_4$ , or by reaction of  $(NSCl)_3$  with  $NO$  in nitromethane. Structural data is lacking, in the absence of a molecular weight determination it is possible that the compound is polymeric.

The compound  $S_3N_3Cl$  has been reported and is possibly<sup>44</sup> an intermediate in the chlorination of  $S_4N_4$ . The compounds<sup>48</sup>  $S_2NCl_2$  and  $S_4N_3Cl_2$  have not yet been confirmed and are of doubtful existence.

**SPECTROSCOPIC STUDIES ON SULPHUR-OXYGEN**

**AND SULPHUR-NITROGEN BONDS**

Infrared spectroscopy affords a powerful tool for the structural characterisation of chemical compounds. The author has been one of the first members of a new sulphur-nitrogen research school. It was considered a useful preliminary to thoroughly review the evidence in the chemical literature regarding the absorptions of sulphur species, S-X, where X may be any element, including sulphur itself. The initial literature survey was done in collaboration with Mr. J.S.Padley, but the final evaluation of the data relating to sulphur-oxygen and sulphur-nitrogen bonds was the responsibility of the author. In this section the available data are collected and discussed and, in the case of sulphur-nitrogen bonds, several new empirical correlations are established.

#### A. SULPHUR-OXYGEN COMPOUNDS

##### Introduction

The infrared and Raman spectra of compounds containing sulphur-oxygen bonds have been extensively studied and several useful correlations have been found<sup>176-180</sup>. In conjunction with an investigation of the spectroscopic behaviour of compounds containing sulphur-nitrogen bonds the evidence relating to sulphur-oxygen bonds has been re-examined in the light of recent experimental evidence. The previously reported correlations

are confirmed, particularly with respect to inorganic compounds. Also, the data relating to oxo-anions of sulphur has been reviewed since many new studies have been reported since these groupings were last considered<sup>181, 182</sup>.

#### Sulphuryl (-SO<sub>2</sub>-) compounds

For -SO<sub>2</sub>- compounds several workers<sup>176-178</sup> have observed a linear relationship between the symmetric S-O stretching ( $\nu_s$  SO<sub>2</sub>) and the asymmetric stretching vibration ( $\nu_{as}$  SO<sub>2</sub>). Bellamy and Williams<sup>178</sup> have commented that such a relationship is to be expected since the -SO<sub>2</sub>- stretching vibrations are essentially free from mass and coupling effects. The data compiled by Robinson<sup>177</sup> are particularly comprehensive and show that the symmetric and asymmetric S-O vibrations for compounds of the types X<sub>2</sub>SO<sub>2</sub>, XYSO<sub>2</sub>, (including X(OH)SO<sub>2</sub>), for ions such as XSO<sub>3</sub><sup>-</sup> and SO<sub>4</sub><sup>2-</sup> and for more complex molecules containing -SO<sub>2</sub>- as part of a ring or chain, all fit the linear relationship satisfactorily. (Fig.10.) Strictly speaking the S-O stretching vibrations of the ionic species should not be described as symmetric and asymmetric. The data considered by Robinson contained relatively few inorganic compounds, and in particular, very little data on the simple oxo-anions of sulphur.

Considerably more data referring to inorganic sulphuryl compounds are now available<sup>183-206</sup> and the  $\nu_s$  SO and  $\nu_{as}$  SO values for these compounds all fit fairly well the line established by Robinson.

Points representing these compounds are shown as + in Fig.10.

Data for various oxo-anions are also available and the behaviour of these is of interest. Table 2 lists the observed frequencies and these are shown as  $\Delta$  in Fig.10.

Table 2  
Symmetric and asymmetric S-O stretching vibrations for  
oxo-anions of sulphur

Species	$\nu_s$ SO (cm <sup>-1</sup> )	$\nu_{as}$ SO (cm <sup>-1</sup> )	Reference
SO <sub>3</sub> <sup>2-</sup>	970	930	207
FSO <sub>2</sub> <sup>-</sup>	1105	1182	208
SO <sub>4</sub> <sup>2-</sup>	981	1104	209
S <sub>2</sub> O <sub>3</sub> <sup>2-</sup>	995	1123	210
S <sub>2</sub> O <sub>6</sub> <sup>2-</sup>	{ 1092 1000	{ 1235 1206	211
S <sub>2</sub> O <sub>7</sub> <sup>2-</sup>	{ 1059 1108	{ 1267 1289	212
RO.SO <sub>2</sub> <sup>-</sup>	1056-1075	1157-1177	213

The values for SO<sub>4</sub><sup>2-</sup> and S<sub>2</sub>O<sub>3</sub><sup>2-</sup> fit reasonably well on the Robinson plot (Fig.10). Values for S<sub>2</sub>O<sub>6</sub><sup>2-</sup> and S<sub>2</sub>O<sub>7</sub><sup>2-</sup> fit less well.

FIG 10  
CORRELATION OF SYMMETRIC AND ASYMMETRIC S-O STRETCHING  
VIBRATIONS

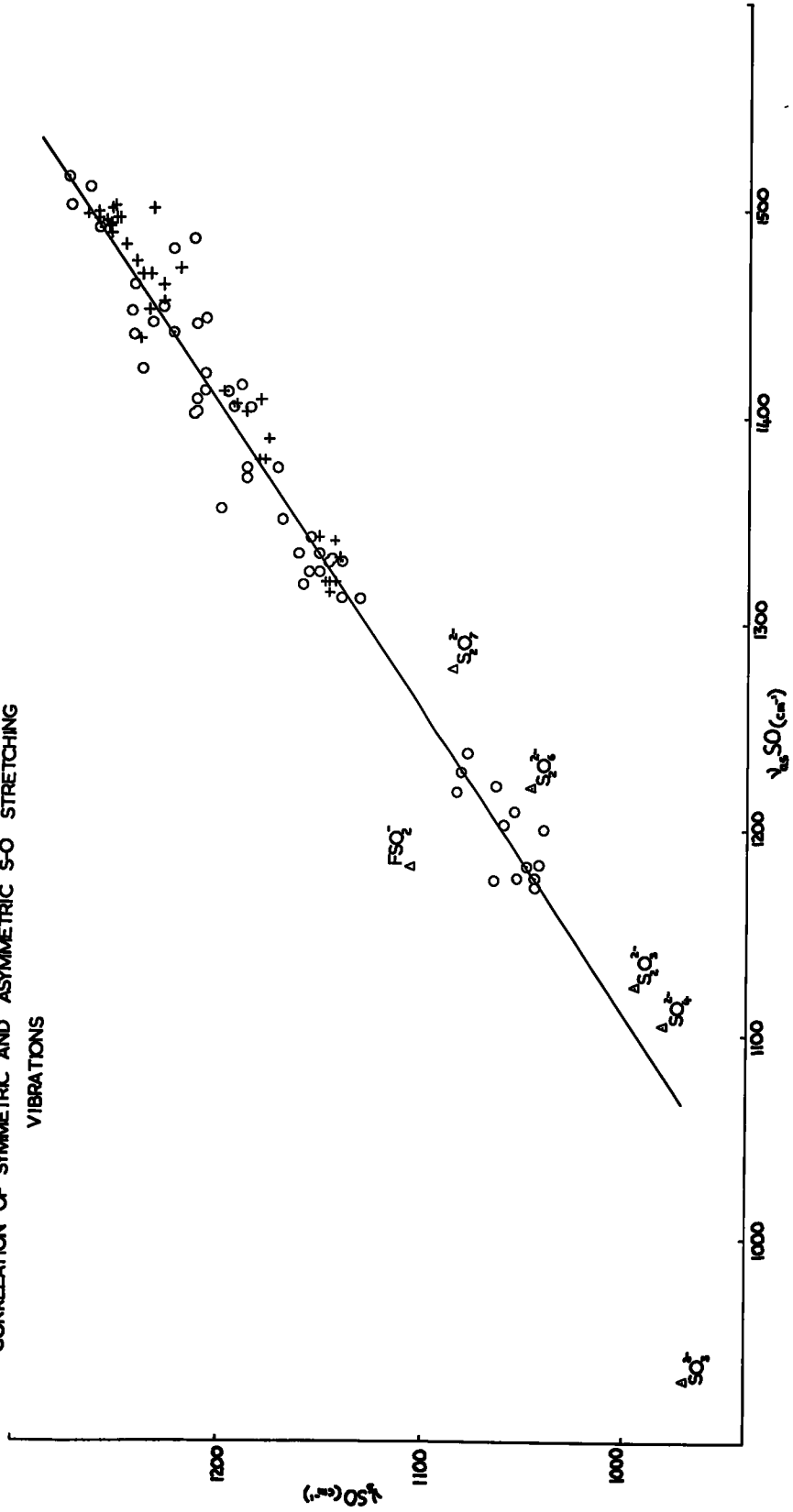
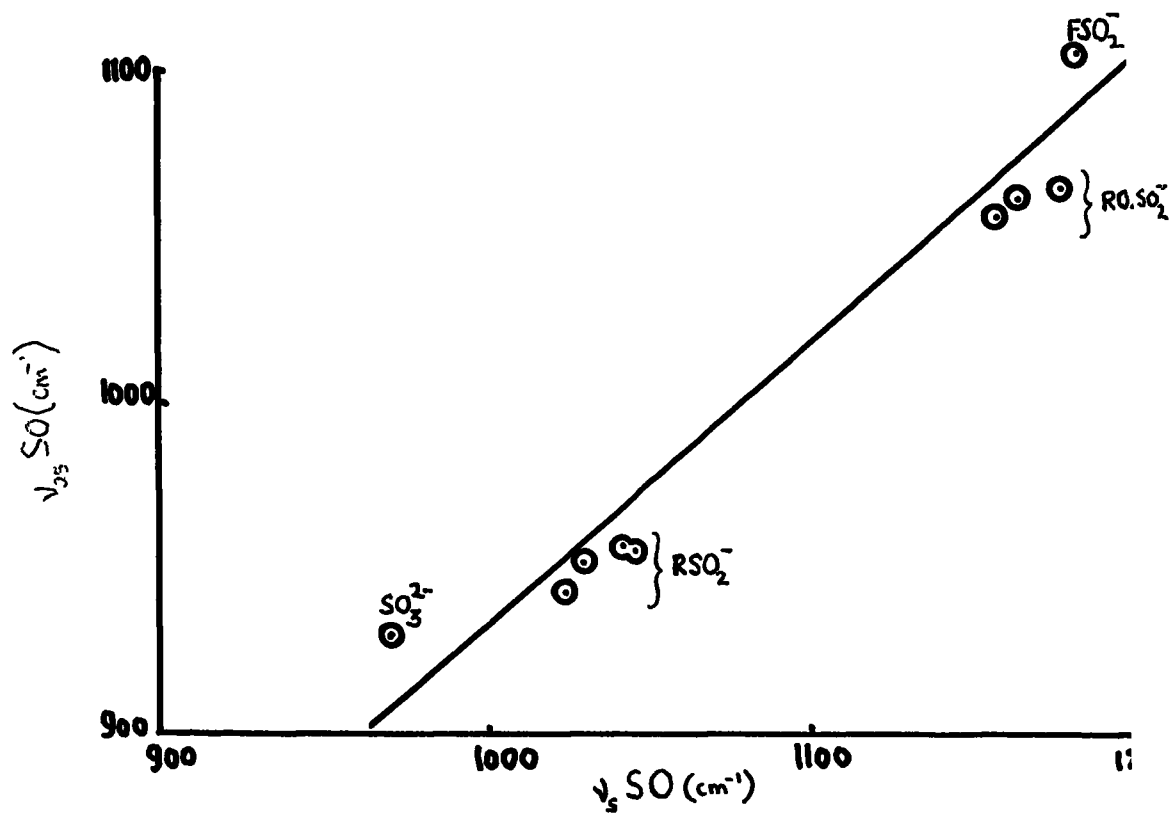



FIG II



CORRELATION BETWEEN SYMMETRIC AND  
ASYMMETRIC S-O FREQUENCIES OF S(IV)  
OXO-ANIONS

Possibly the scatter in these values results from the mixed character of the vibrations or inaccuracy in the reported values because of the difficulty of resolving bands in the fairly complex spectra. The points representing the sulphur(IV) species,  $\text{SO}_3^{2-}$  and  $\text{FSO}_2^-$  lie well away from the line though the analogous  $\text{RO}\cdot\text{SO}_2^-$  compounds fit satisfactorily. The reported assignments for the  $\text{XSO}_2^-$  ions are based upon comparison with sulphur(VI) compounds for which  $\nu_{\text{as}} \text{SO} > \nu_{\text{s}} \text{SO}$ . It would seem more reasonable to assign these sulphur(IV) compounds by analogy with the sulphite ion for which  $\nu_{\text{s}} \text{SO} > \nu_{\text{as}} \text{SO}$ . It is considered significant that in this case all of the sulphur(IV) species lie on a new straight line (Fig.11), which suggests that the line established by Robinson<sup>177</sup> is applicable only to compounds of sulphur(VI). Fig.11 contains data for the  $\text{RSO}_2^-$  ions<sup>214</sup> for which assignments of the symmetric and asymmetric stretching modes were made by the author. The determination of Raman polarisation data for the  $\text{XSO}_2^-$  ions would enable an unambiguous assignment of the symmetric and asymmetric S-O stretching modes.

Table 3 lists the frequencies observed for various types of  $-\text{SO}_2^-$  compounds. In general, as the effective electronegativity of the attached ligands is increased the S-O stretching vibrations are shifted to higher frequencies. This shift indicates

Table 3

Correlation table for S-O symmetric and asymmetric vibrations

Grouping	Type of compound	S-O (cm <sup>-1</sup> )	
		symmetrical	asymmetrical
C-SO <sub>2</sub> -C	Sulphones(alkyl)	1136-1145	1307-1330
	Sulphones(alkyl-aryl)	1150-1160	1325-1334
	Sulphones(aryl)		
C-SO <sub>2</sub> -N	Sulphonamides	1152-1169	1336-1358
C-SO <sub>2</sub> -N	e.g. F <sub>3</sub> CSO <sub>2</sub> N <sub>3</sub>	1236	1437
C-SO <sub>2</sub> -O	Sulphonic acids and esters	1165-1185	1350-1375
C-SO <sub>2</sub> -F	Sulphonyl fluorides	1203-1210	1401-1412
C-SO <sub>2</sub> -Cl	Sulphonyl chlorides	1169-1185	1364-1390
C-SO <sub>2</sub> -S	Thiosulphonates	1144-1154	1331-1342
N-SO <sub>2</sub> -N	Sulphamide and derivatives.(b)	1140-1168	1320-1398
O-SO <sub>2</sub> -O	Covalent sulphates	1187-1195	1390-1415
O-SO <sub>2</sub> -O	e.g. (SF <sub>5</sub> O) <sub>2</sub> and SF <sub>5</sub> O.SF <sub>4</sub> O.SO <sub>2</sub> .OSF <sub>2</sub> (b)	1230-1256	1469-1500
O-SO <sub>2</sub> -F	e.g. FSO <sub>3</sub> F, HSO <sub>3</sub> F, S <sub>2</sub> O <sub>5</sub> F <sub>2</sub> , S <sub>2</sub> O <sub>8</sub> F <sub>2</sub> (c)	1230-1277	1445-1510
O-SO <sub>2</sub> -Cl	e.g. HSO <sub>3</sub> Cl, S <sub>2</sub> O <sub>5</sub> Cl <sub>2</sub> , S <sub>2</sub> O <sub>8</sub> Cl <sub>2</sub> , S <sub>3</sub> O <sub>8</sub> Cl <sub>2</sub>	1205-1225	1408-1452
N-SO <sub>2</sub> -F	= NSO <sub>2</sub> F and -N(SO <sub>2</sub> F) <sub>2</sub> compounds	1174-1250	1337-1495
	SO <sub>2</sub> Cl <sub>2</sub>	1269	1502
	SO <sub>2</sub> F <sub>2</sub>	1182	1414
	Ions, e.g., RSO <sub>3</sub> <sup>-</sup> , excluding		
	oxo-anions(d)	1026-1080	1175-1221

- a: after Robinson<sup>177</sup>
- b: groupings not given by Robinson
- c: these frequency ranges confirmed by inclusion of data not considered by Robinson
- d: see text

increasing strength of the S-O bonds which is most plausibly explained as resulting, at least in part, from increased double bond character.

#### Oxo-anions and complexes

The characteristic ranges over which the S-O stretching vibrations in oxo-anions occur are given in Fig.13. For the less common anions the ranges shown are based upon only a few reported spectra, usually of alkali metal salts, and are, therefore, somewhat tentative.

#### Sulphites

The free ion has pyramidal  $C_{3v}$  symmetry giving rise to four infrared and Raman active fundamental modes. The fundamental frequencies have been calculated<sup>207</sup> as:

$\nu_1$  (symmetric stretch), 970 cm.

$\nu_2$  (symmetric bend), 630 cm.

$\nu_3$  (asymmetric stretch), 930 cm.

$\nu_4$  (asymmetric bend), 480 cm.

Both  $\nu_3$  and  $\nu_4$  are doubly degenerate and any deviation from  $C_{3v}$  symmetry, e.g. coordination through oxygen atoms, can lead to splitting of modes. In several reported cases  $\nu_1$  and  $\nu_3$  are not resolved,<sup>181, 215-217</sup> or only partially resolved, with the result that a single broad band is observed with a maximum at  $950-970\text{cm}^{-1}$ .

FIG. 13.

## S-O STRETCHING FREQUENCIES IN OXO-ANIONS

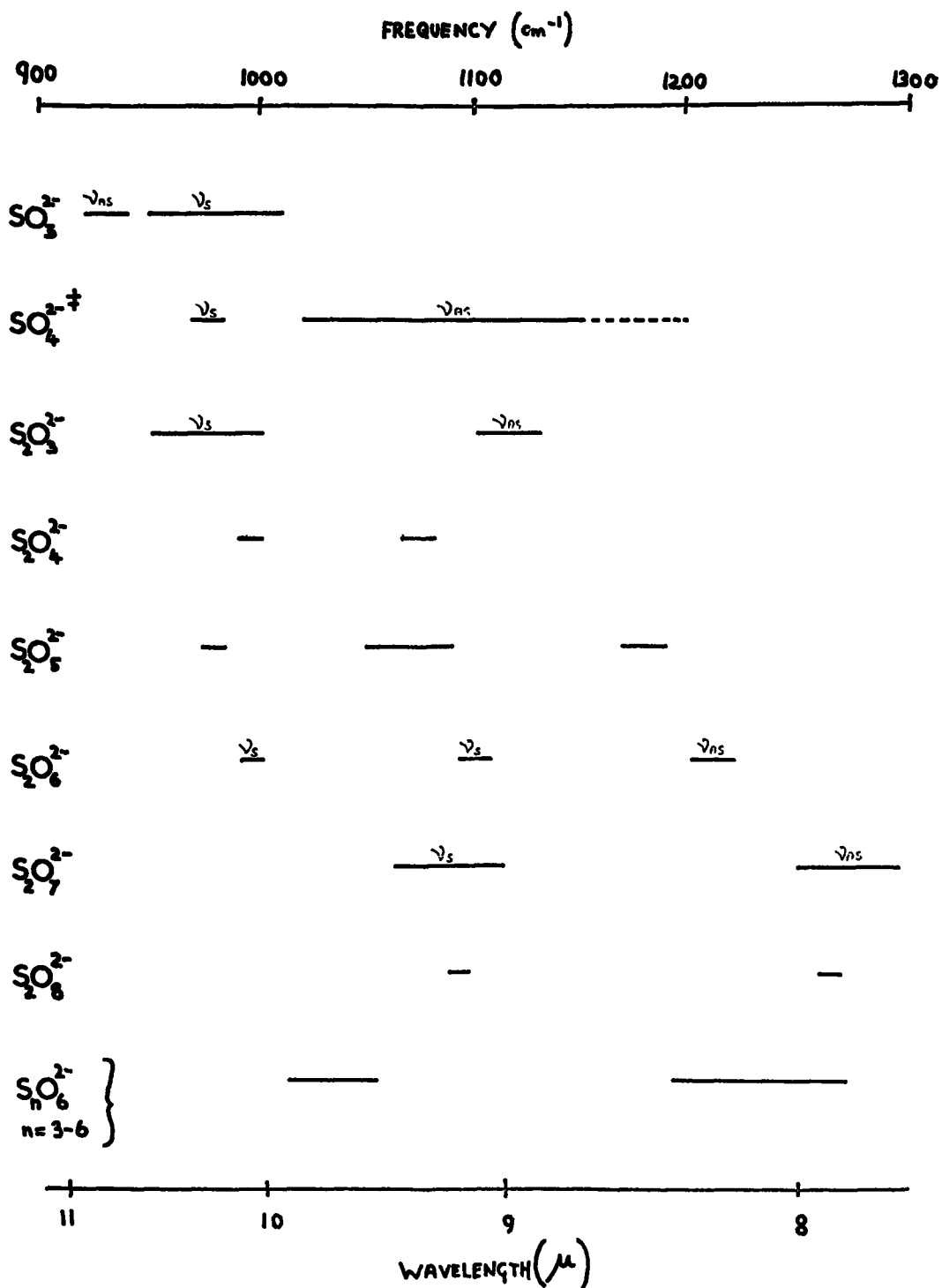
(\* FEW COMPOUNDS ABSORB AT 1150-1200  $\text{cm}^{-1}$ )

For compounds which have been studied under conditions such that  $\nu_1$  and  $\nu_3$  are resolved<sup>207,218-220</sup> no splitting of  $\nu_3$  is observed, which suggests that in simple compounds the  $C_{3v}$  symmetry of the free ion is essentially undisturbed. Since a given compound can be reported with  $\nu_1$  and  $\nu_3$  resolved by one author and unresolved by another it seems probable that instrumental factors may be the determining factor. The fundamental frequencies observed in the Raman may differ from those in the infrared. Thus, Evans and Bernstein<sup>218</sup> in a study of aqueous solutions of  $Na_2SO_3$  found the fundamentals to occur at  $\nu_1 = 967\text{cm}^{-1}$ ,  $\nu_2 = 620\text{cm}^{-1}$ ,  $\nu_3 = 953\text{cm}^{-1}$ , and  $\nu_4 = 469\text{cm}^{-1}$  in the Raman whilst the corresponding infrared frequencies were 1002, 632 and  $95\frac{1}{2}\text{cm}^{-1}$ ,  $\nu_4$  not being observed. The effect is ascribed to strong intermolecular forces and, as is usual, the infrared bands have the higher frequencies.

### Sulphates

The free ion has tetrahedral,  $T_d$ , symmetry and hence four fundamental modes for which the calculated frequencies, assuming central forces,<sup>209</sup> are:

$$\nu_1 \text{ (symmetric stretch), } 981 \text{ cm}^{-1}$$

$$\nu_2 \text{ (degenerate bend), } 451 \text{ cm}^{-1}$$

$$\nu_3 \text{ (asymmetric stretch), } 220\frac{1}{2} \text{ cm}^{-1}$$

$$\nu_4 \text{ (degenerate bend), } 613 \text{ cm}^{-1}$$

$\nu_2$  is doubly degenerate and both  $\nu_3$  and  $\nu_4$  are triply degenerate.

All four modes are Raman active but only  $\nu_3$  and  $\nu_4$  are active in the infrared. The observed Raman frequencies in various crystalline environments are given in Table 4. It is seen that doubly and triply degenerate modes may split into two and three components respectively. Infrared spectra<sup>181, 182</sup> normally show only bands due to  $\nu_3$  and  $\nu_4$  though in some cases slight lowering of the symmetry brought about by crystal forces causes  $\nu_1$  to become weakly infrared active<sup>181</sup>.

Table 4  
Raman frequencies of sulphate ion in various crystalline environments.<sup>a</sup>

Compound	$\nu_1$ (cm <sup>-1</sup> )	$\nu_2$ (cm <sup>-1</sup> )	$\nu_3$ (cm <sup>-1</sup> )	$\nu_4$ (cm <sup>-1</sup> )
Na <sub>2</sub> SO <sub>4</sub>	983	454	1106	622
BaSO <sub>4</sub>	989	(453 462)	(1094 1142 1167)	(617 630 648)
CaSO <sub>4</sub>	1018	(415 499)	(1108 1128 1160)	(609 628 674)

a: from Krishnan<sup>221</sup>.

Whilst the perturbing effect of the cation on the sulphate ion symmetry is usually small, in the case of Indium sulphate<sup>222</sup> it is sufficiently great for new polarised lines to appear in the Raman spectrum and these have been accounted for in terms of a  $\text{InSO}_4^-$  species of  $C_{3v}$  symmetry. Decius<sup>223,224</sup> has shown



that when the alkaline earth sulphates are present in small amounts in KBr or KCl crystals, the ion symmetry is reduced to  $C_{2v}$ . The general effects of crystal forces on the spectra of solid sulphates have been discussed by several workers<sup>225-230</sup> as have the differences between solid and solution spectra, which result from the lower symmetry of the solid phase<sup>231-233</sup>.

Guerchais et.al.<sup>227</sup> have related displacements of the  $\nu_1$  and  $\nu_3$  bands to the ionic radius of the cation in a series of alkali metal sulphates. The displacement is a linear function of the ionic radius of the cation, the shift being to lower frequency with increase in ionic radius. The spectra of hydrated sulphates may differ from those of the corresponding anhydrous salts, usually as a result of hydrogen bond formation.<sup>234-238</sup>

For compounds of the type  $M(H_2O)_6SO_4 \cdot H_2O$ , where  $M=Mg, Ni, Co, Zn$ ,  $\nu_3$  is at  $\sim 1085 \text{ cm}^{-1}$  compared with approximately  $1150 \text{ cm}^{-1}$  for the anhydrous compounds.<sup>234a</sup> Cho et.al.<sup>239</sup> have suggested that  $MgSO_4 \cdot H_2O$  exists in the form  $Mg(OH)HSO_4$  because of the presence of a band at  $\sim 870 \text{ cm}^{-1}$  which they assign to the  $HSO_4^-$  ion. On the other hand Oswald<sup>238</sup> having studied the infrared and N.M.R. spectra of a series of monohydrates, concluded that the forms  $MSO_3(OH)_2$  and  $M(OH)HSO_4$  were not present and that the compounds were normal sulphates containing strongly bound water molecules.

Tai and Underwood<sup>240</sup> have combined freeze drying with the KBr disc technique to study the infrared spectra of aqueous sulphate solutions.

The shape of the  $\nu_3$  band at  $\sim 1120 \text{ cm}^{-1}$  was found to vary with the cation and they suggest that the sharp band of  $\text{K}_2\text{SO}_4$  is the most suitable for analytical purposes.

Considerably more data on the Raman and infrared spectra of the sulphate ion are reported. Ammonium and group 1 sulphates are reported in refs;<sup>225, 241-244</sup> group 2 compounds in refs.<sup>245-247</sup>; group 3 compounds in ref.<sup>248</sup> and compounds containing transition metal ions in refs.<sup>249-255</sup>. Compounds of the type  $(\text{NH}_4)_2\text{M}(\text{SO}_4)_2 \cdot 6\text{H}_2\text{O}$  have been considered by Anantharayanan<sup>256</sup>. The infrared spectrum of iodosyl sulphate shows the  $(\text{IO})^+$  cation to be polymeric<sup>257</sup>. Several workers<sup>247, 258-265</sup> have discussed the spectrum of sulphuric acid, which provides evidence concerning possible ionisation processes. The general spectral characteristics of the sulphate ion are reported by various other workers.<sup>266-270</sup> Jaulmes<sup>271</sup> and Keller *et.al.*<sup>272</sup> have examined the spectra of sulphate minerals and Buijs<sup>273</sup> has examined the spectrum of the sulphate ion when absorbed on an ion exchange resin.

### Thiosulphates

The free ion has tetrahedral  $\text{C}_{3v}$  symmetry and hence six fundamental modes all infrared and Raman active. The calculated frequencies<sup>210</sup> are:

$\nu_1$  (symmetric S-O stretch),  $995 \text{ cm}^{-1}$

$\nu_2$  (symmetric S-O bend),  $669 \text{ cm}^{-1}$

- $\nu_3$  (S-S stretch)  $435 \text{ cm}^{-1}$   
 $\nu_4$  (asymmetric S-O stretch)  $1123 \text{ cm}^{-1}$   
 $\nu_5$  (asymmetric S-O bend)  $541 \text{ cm}^{-1}$   
 $\nu_6$  ( $-\text{SO}_3$  rocking),  $335 \text{ cm}^{-1}$

Miller and Wilkins<sup>181</sup> have reported the spectra of several thiosulphates. The band at  $670 \text{ cm}^{-1}$  is often broad and the maximum occurs over the range  $640\text{-}680 \text{ cm}^{-1}$ . The S-O stretching modes ( $\nu_1 = 950\text{-}1000 \text{ cm}^{-1}$ ) are, with the exception of the ammonium compound, well defined. Buijs<sup>273</sup> has examined the spectra of thiosulphates on an ion-exchange resin; the spectra are essentially unchanged though new bands appear due to  $\text{S}_4\text{O}_6^{2-}$  ions formed by the facile atmospheric oxidation of thiosulphate under these conditions.

#### Other oxo-anions

Simon<sup>274</sup> has examined the Raman spectrum of the dithionite ion ( $\text{S}_2\text{O}_4^{2-}$ ) and reported S-O stretching modes at  $1070$  and  $998 \text{ cm}^{-1}$ . The pyrosulphite ion  $\text{S}_2\text{O}_5^{2-}$  has been studied by Simon *et.al.*<sup>275</sup> who concluded that an SOS grouping was present and interpreted their infrared and Raman data on the basis of  $\text{C}_{2v}$  symmetry. However, X-ray analysis shows the presence of an S-S bond in a structure of  $\text{C}_s$  symmetry. Buijs<sup>273</sup> in a more recent examination of the infrared spectrum has reported five fundamentals in the S-O stretching region as expected on the basis of the required

$C_{2v}$  symmetry. The assignment of the fundamental frequencies of the dithionate ion ( $S_2O_6^{2-}$ ) is subject to some controversy. Palmer<sup>211</sup> from a study of the Raman and infrared spectra of the sodium and potassium salts has assigned the S-O stretching frequencies, on the basis of  $D_{3d}$  symmetry, as follows:

$\nu_7$  (asymmetric S-O stretch), 1235-1240  $cm^{-1}$

$\nu_{10}$  (asymmetric S-O stretch), 1206-1216  $cm^{-1}$

$\nu_5$  (symmetric S-O stretch), 996-1000  $cm^{-1}$

$\nu_1$  (symmetric S-O stretch), 1092-1102  $cm^{-1}$

On the other hand, Buijs<sup>273, 276</sup> however has interpreted his infrared data, in conjunction with the Raman studies of Duval and Lecomte<sup>271</sup> to suggest that the fundamental should be assigned as,  $\nu_7 = 994$  and  $998$   $cm^{-1}$ ,  $\nu_{10} = 1212$   $cm^{-1}$ ,  $\nu_5 = 1230$  and  $1243$   $cm^{-1}$  and  $\nu_1 = 1200$   $cm^{-1}$ . Compounds containing S(VI) have been found to give rise to symmetrical and asymmetrical stretching frequencies which vary linearly with one another (Fig.10). The assignments made by Palmer give rise to average values of,  $\nu_{S}SO = 1046$   $cm^{-1}$  and  $\nu_{as}SO = 1221$   $cm^{-1}$ , which fit this general relationship fairly well. The corresponding values from Buijs assignments are,  $\nu_{S}SO = 1237$   $cm^{-1}$  and  $\nu_{as}SO = 1068$   $cm^{-1}$ , which do not fit the straight line. The effect of site symmetry on the fundamental frequencies has been discussed by Buijs<sup>276</sup>.

Simon et.al.<sup>212</sup> have studied the infrared and Raman spectra of the disulphate ion ( $S_2O_7^{2-}$ ) and have interpreted their data in terms of  $C_{2v}$  symmetry. Symmetric S-O stretching modes occur in the infrared at 1060 and 1110  $cm^{-1}$ , the corresponding asymmetric modes being at 1249-1267 and 1289-1295  $cm^{-1}$ . Similar frequencies are observed in the Raman spectra. Bands at approx. 740 and 800  $cm^{-1}$  were assigned to the symmetric and asymmetric SOS stretching modes, respectively, in agreement with the assignments of Dupuis and Viltange<sup>278</sup>. Gillespie and Robinson<sup>279</sup>, however, have assigned frequencies of  $\sim 150$ ,  $\sim 300$  and  $\sim 800$   $cm^{-1}$  to the bend, symmetric stretch and asymmetric stretch, respectively, of the SOS group in molecules of the type  $X_nSOSX_n$ , including  $S_2O_7^{2-}$ . Further, these authors have shown that there exist linear relationships between the symmetric stretching and bending modes of the SOS group and the square root of the mass of the groups  $SX_n$  attached to the oxygen atom. For the disulphate ion SO bending modes occur<sup>278</sup> at  $\sim 520$  (symmetric) and  $\sim 590$   $cm^{-1}$  (asymmetric).

The Raman and infrared spectra of several peroxodisulphates ( $S_2O_8^{2-}$ ) have been examined by Simon and Richter<sup>280</sup> who assigned a band at 1267  $cm^{-1}$  in both spectra to an S-O stretching vibration. Since the  $S_2O_8^{2-}$  ion contains S(VI), its symmetric and asymmetric

frequencies are expected to fit the linear relationship shown in Fig.10. If the  $1267\text{ cm}^{-1}$  band is assigned to the asymmetric mode then the band observed at  $1088\text{ cm}^{-1}$  in the Raman, (not assigned by Simon and Richter) is in the region expected for the symmetric stretch.

The spectrum of the tetrathionate ion  $\text{S}_4\text{O}_6^{2-}$  has been discussed in some detail by Buija<sup>273</sup>. There are six fundamental S-O stretching modes and these occur in the regions  $1010\text{-}1050\text{ cm}^{-1}$  and  $1200\text{-}1250\text{ cm}^{-1}$ . As expected these frequencies are close to those observed for the  $\text{S}_2\text{O}_6^{2-}$  ion. Schmidt and Sand<sup>281</sup> have assigned bands in these same regions to the S-O vibrations of  $\text{K}_2\text{S}_2\text{O}_6$  and these same authors<sup>282</sup> have shown that the infrared spectra of the ions  $\text{S}_n\text{O}_6^{2-}$ , where  $n = 3 - 6$ , are similar.

#### Complexes containing oxo-anions as ligands

##### (i) Sulphito-compounds

Compounds of the types  $\text{M}_2^{\text{I}}\text{M}^{\text{II}}(\text{SO}_3)_2$  and  $\text{M}^{\text{I}}\text{CuSO}_3$ , have simple spectra typical of the free ion and, therefore, are double salts and not complexes<sup>217</sup>. When functioning as a unidentate ligand the sulphite group may bond through either sulphur or oxygen. The  $\text{C}_{3v}$  symmetry of the free ion will be essentially undisturbed if S-bonding occurs and the infrared spectra of complexes<sup>217, 283, 284</sup> of  $\text{Co}^{\text{III}}$ ,  $\text{Rh}^{\text{III}}$ ,  $\text{Ir}^{\text{III}}$ ,  $\text{Pd}^{\text{II}}$ ,  $\text{Pt}^{\text{II}}$  and  $\text{Hg}^{\text{II}}$  are in accordance with this suggestion. Bonding through oxygen lowers

the symmetry to  $C_s$ , causing more profound changes in the spectrum;  $Tl_2(Cu(SO_3)_2)$  is the only compound for which O-bonding is reported<sup>217</sup>.

When occupying two coordination positions the sulphito group may be bidentate or bridging. As is the case with sulphato-compounds it seems doubtful<sup>217</sup> if infrared data can distinguish between the two possibilities. Whilst Baldwin<sup>283</sup> interpreted the infrared spectrum of  $(Coen_2SO_3)Cl$  to show that the sulphito group is bidentate, Newman and Powell<sup>217</sup> found that the spectrum of  $(Coen_2SO_3)Cl$  was similar to those of  $K_2(Pt(SO_3)_2) \cdot 2H_2O$ ,  $Na_3(Co(SO_3)_3) \cdot 4H_2O$  and  $K_3(Rh(SO_3)_3) \cdot 2H_2O$ . They concluded that infrared data alone could not distinguish between the two possible structures. These latter authors discussed the infrared data in some detail and commented upon Baldwin's<sup>283</sup> interpretation of her data. On the other hand, Babaeva and Kharitonov<sup>285</sup> have suggested that the infrared spectra support the assignment of structures involving bridging sulphito-groups to  $(Co(SO_3)_3)^{3-}$  and  $(Rh(SO_3)_3)^{3-}$ . The spectrum<sup>217</sup> of  $K_2(Pd(SO_3)_2)$  indicates that its structure may differ from that previously suggested<sup>286</sup>.

(ii) Sulphato-compounds

Nakamoto et.al.<sup>287</sup> have discussed the spectra of both unidentate and bidentate sulphato-groups. When the group

functions as a unidentate ligand e.g. in  $(\text{Co}(\text{NH}_3)_5 \cdot \text{SO}_4)\text{X}$  compounds<sup>287, 288</sup> the symmetry is lowered to  $\text{C}_{3v}$ , whilst in the case that bridging occurs, e.g.

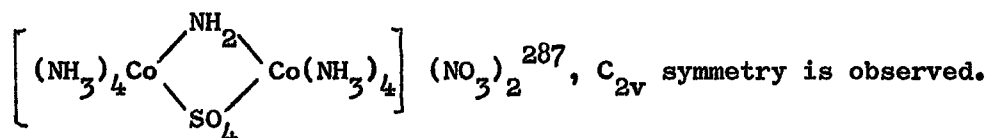

Barraclough and Tobe<sup>289</sup> from a study of the spectrum of  $(\text{Co} \cdot \text{en} \cdot \tilde{\text{SO}}_4)\text{Br}$  have concluded that it is not possible to distinguish between bridging and chelating sulphato-groups using infrared data only. On the other hand McWhinnie<sup>253</sup> and Eskenazi et.al.<sup>290</sup> have suggested that the high energy band of the  $\nu_3$  mode occurs at higher frequencies in complexes containing chelating sulphato groups ( $1210\text{-}1240 \text{ cm}^{-1}$ ) than in those containing the bridging ligand ( $1160\text{-}1195 \text{ cm}^{-1}$ ). The spectra of some protactinium di- and tri-sulphato complexes have been reported and discussed<sup>291</sup>. Both uni- and bidentate sulphato groups may be present and since the various possibilities could not be differentiated the coordination of the protactinium remains uncertain. Baldwin<sup>292</sup> has discussed the spectra of various complex sulphates and of compounds of the types,  $\text{Y}_2\text{SO}_4 \cdot \text{MSO}_4 \cdot 6\text{H}_2\text{O}$  and  $\text{Y}_2\text{SO}_4 \cdot \text{X}_2(\text{SO}_4)_3 \cdot 24\text{H}_2\text{O}$ , i.e., Tutton salts and alums. It appears that these hydrated compounds may give rise to quite complex spectra and



Baldwin concludes that whilst a simple spectrum indicates an undistorted sulphato-group it does not necessarily follow that a complicated band structure shows conclusively coordination to a metal or even significant deviation from a tetrahedral structure.

Livingstone<sup>293</sup> has recently reviewed the metal complexes of ligands containing sulphur as a donor atom; sulphito and thiosulphato complexes were discussed by this author.

~~(III)~~ Thionyl(-SO-) compounds

Table 5 shows the S-O stretching frequencies observed in various thionyl compounds. With the sulphoxides, R<sub>2</sub>SO, considerable molecular aggregation occurs in the liquid phase with the result<sup>294-296</sup> that

$$\nu_{\text{SO}}(\text{liquid}) < \nu_{\text{SO}}(\text{solution}) < \nu_{\text{SO}}(\text{vapour})$$

and because of the considerable solute-solvent interactions that can arise with these compounds the observed solution frequency is markedly solvent dependant.<sup>297</sup> The range quoted in Table

5 covers the frequencies observed in CCl<sub>4</sub> and CS<sub>2</sub> solutions.

In contrast to the sulphones it is not possible to differentiate between compounds having R=aryl and those having R=alkyl.

Barnard et.al.<sup>294</sup> have suggested that the constancy of  $\nu_{\text{SO}}$  at 1055 cm<sup>-1</sup> for several sulphoxides arises from the fact that

Table 5

S-O stretching frequencies in thionyl compounds

type of compound	$\nu_{\text{SO}}$ (cm <sup>-1</sup> )
simple sulphoxides, R <sub>2</sub> SO, (R=aryl, alkyl, alkenyl)	1010-1070 <sup>a</sup>
cyclic sulphoxides, (CH <sub>2</sub> ) <sub>n</sub> SO	1039-1055, 1192 <sup>b</sup>
(CH <sub>2</sub> O) <sub>2</sub> SO	1220
disulphoxides	1036-1088
dimethyl sulphoxide- metal complexes	978-1037 <sup>c</sup>
tetramethylene sulphoxide- metal complexes	950
S-alkylsulphoxonium compounds	1210-1240
O-methylsulphoxonium nitrate	925-1050
SOX <sub>2</sub> (X=F, Cl, Br.)	X=F, 1308, X=Cl, 1251 X=Br, 1121
SO <sub>4</sub> <sup>k</sup>	1379

a: see text for variation of  $\nu_{\text{SO}}$ .

b: when n=4,  $\nu_{\text{SO}} = 1194 \text{ cm}^{-1}$ , this value is anomalously high.

A similar situation arises with the cyclic ketones.<sup>296</sup>

c: except Pd<sup>II</sup> and Pt<sup>II</sup> complexes, see text.

negligible coupling occurs between the S-O vibration and the lower frequency C-S vibration, and Price and Gillis<sup>298</sup> report that negligible conjugation occurs between C=C and S=O bonds in alkyl-alkenyl sulphoxides. Coupling between the S-O stretching and CH<sub>3</sub> rocking modes in dimethyl sulphoxide is, however, well substantiated and leads to some difficulty in the assignment of  $\nu_{SO}$  in dimethyl sulphoxide-metal complexes. Lappert and Smith<sup>301</sup>, Cotton *et.al.*<sup>295</sup> and Holah and Fackler<sup>302</sup> have assigned a band at 900-950 cm<sup>-1</sup> to the S-O stretching vibration in a wide variety of dimethyl sulphoxide complexes and have concluded that since in these complexes  $\nu_{SO}$  occurs at lower frequencies than in the free ligand, the ligand is bonded through the oxygen atom of the S=O bond. Kaufmann and Leroy<sup>303</sup> have given a normal coordinate analysis of the O-bonded complex,  $UO_2Cl_2 \cdot 3(CH_3)_2SO$ ; the bond order of the S=O bond is decreased by ~12% as a result of complex formation. Complexes of Pd<sup>II</sup> and Pt<sup>II</sup> are exceptions to this general rule<sup>295, 304, 306</sup> as are complexes of the type  $C_5H_5Mn(CO)_2D$ , where D may be various sulphoxides<sup>307</sup>, in that the ligands are bound through the sulphur atom with the result that  $\nu_{SO}$  is at a higher frequency than in the free ligand. Drago *et.al.*<sup>300, 308</sup> assign a band at ~1000cm<sup>-1</sup> to the S-O stretch in the 'normal' O-bonded complexes and suggest that the 900-950 cm<sup>-1</sup>

band is due to a  $\text{CH}_3$  rocking mode since its frequency remains fairly constant in many complexes, whilst that of the band at  $\approx 1000 \text{ cm}^{-1}$  varies with the metal ion. These authors suggest that considerable coupling occurs between these two modes so that when  $\nu_{\text{SO}}$  is less than  $990 \text{ cm}^{-1}$ , e.g. in  $\text{Cu}^{\text{II}}$  complexes, the assignment of " $\nu_{\text{SO}}$ " is very difficult. Since the extent to which the S-O vibration is involved in coupling interactions will vary with the sulphoxide it is dangerous to use the shift in  $\nu_{\text{SO}}$  which occurs on complex formation as a measure of the variation of bond strengths for various ligands<sup>304</sup>. The infrared spectra of sulphoxide complexes with  $\text{I}_2$  and  $\text{ICN}$  indicate that in these compounds also the bonding is through the oxygen atom<sup>309</sup>.

#### Correlation between stretching frequency and molecular parameters

The nature of the sulphur-oxygen bond in sulphuryl ( $\text{XYSO}_2$ ) and thionyl ( $\text{XYSO}$ ) compounds has been discussed by Gillespie and Robinson<sup>310</sup>. These authors consider that the two possible extreme forms of the S-O bond may be represented as

(I) and (II)



Structure (I) represents a situation in which the bonding electrons are equally shared and arises when the other atoms attached to

sulphur have electronegativities sufficiently great to raise the effective electronegativity of sulphur to that of oxygen. This situation is approached in  $\text{SO}_2\text{F}_2$  and  $\text{SOF}_4$ . With decreasing electronegativity of the attached groups the bond becomes polar and in the limit the  $\pi$ -bond electron pair resides essentially on the oxygen atom and structure (II) results. The observed frequencies for sulphuryl compounds and  $\text{S}^{\text{VI}}$  containing anions are in agreement with these suggestions (Table 3). The highest frequencies ( $1270$  and  $1502 \text{ cm}^{-1}$ ) are found for  $\text{SO}_2\text{F}_2$  and the lowest ( $981$  and  $1104 \text{ cm}^{-1}$ ) are those of the sulphate ion. Similarly, for the sulphoxides  $\text{X}_2\text{SO}$  the highest frequency ( $1308 \text{ cm}^{-1}$ ) is found for  $\text{SOF}_2$ . For  $\text{SOF}_4$  the frequency is even higher ( $1379 \text{ cm}^{-1}$ ) than in  $\text{SOF}_2$  which is consistent with the presence of two additional highly electronegative ligands. Increasing electronegativity of the groups X and Y should increase the order of the SO bond, and since the lengths of the SO bonds may be assumed to be related to their bond order, a correlation is to be expected between stretching frequency and bond lengths. This relationship has been verified by Gillespie and Robinson<sup>310</sup> and is illustrated in Fig. 4. In the case of  $-\text{SO}_2-$  compounds the appropriate stretching frequency was calculated<sup>311</sup> from the equation

$$\nu_{\text{SO}} = \frac{1}{x} \nu_{\text{S}} \text{SO} + (x-1) \nu_{\text{as}} \text{SO} \quad \dots\dots\dots 1$$

FIG. 14.

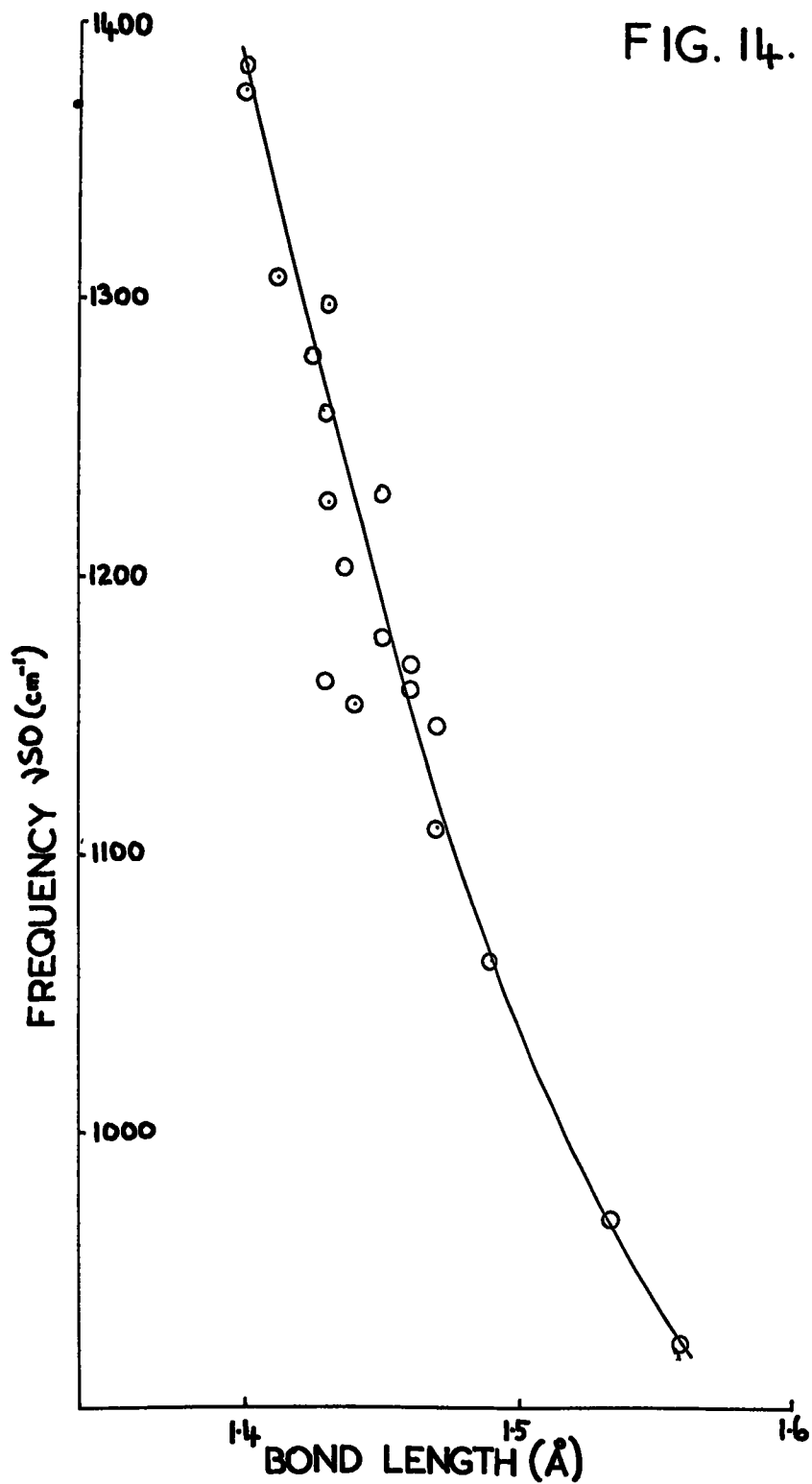

CORRELATION OF S-O STRETCHING FREQUENCY  
WITH BOND LENGTH<sup>310</sup>

FIG. 15.

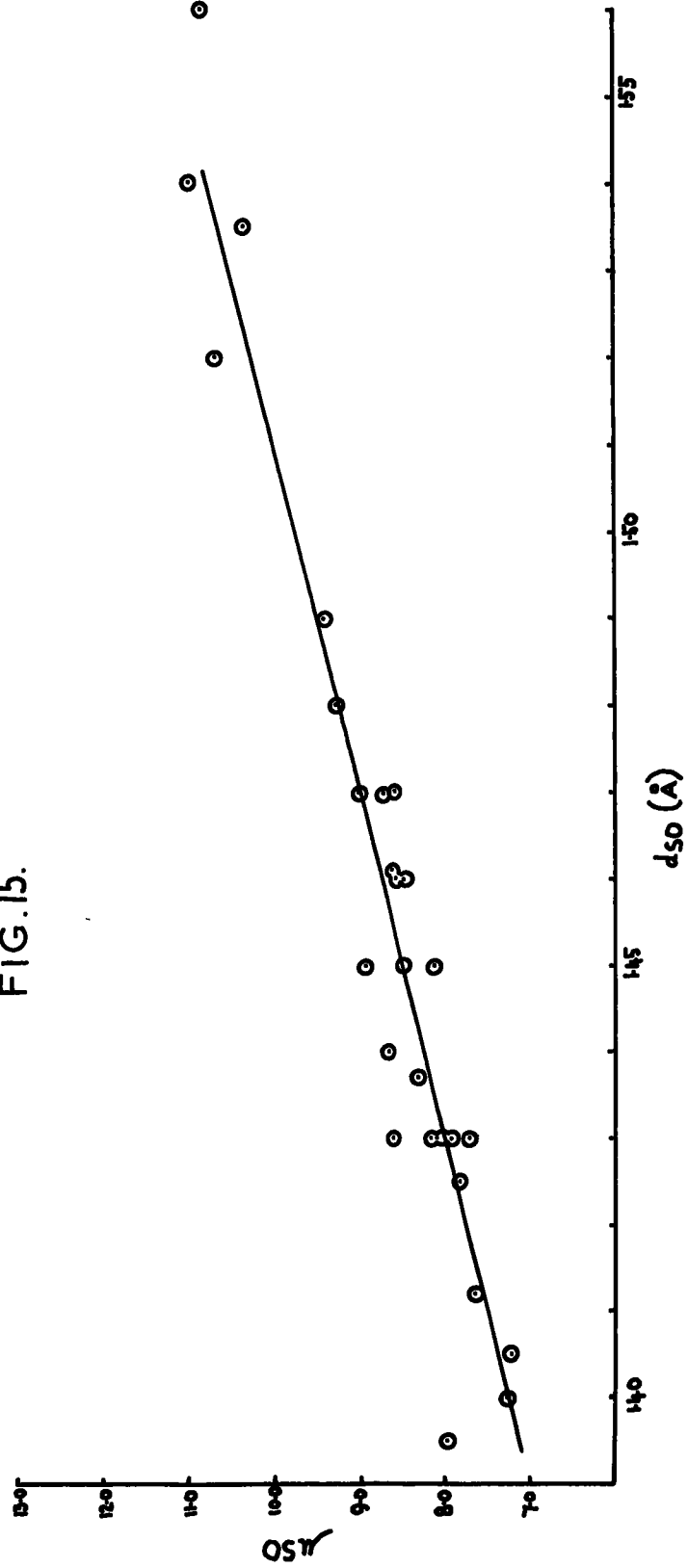

CORRELATION OF WAVELENGTHS ( $\mu$ ) AND BOND DISTANCES FOR

S-O BONDS

where  $(x-1)$  is the degeneracy of the asymmetric vibration.

The scatter of the points in Fig. 14 is, in general, not greater than  $\pm 0.02\text{\AA}$  which is of the order of the experimental error of most bond lengths determinations.

For several compounds not considered by Gillespie and Robinson both bond lengths and stretching frequencies are now available so that values of the bond length predicted from Fig. 14 may be compared with the experimental value. The appropriate data is given in Table 6.

Table 6

Some predicted and observed values of sulphur oxygen bond length ( $d_{\text{S-O}}$ ).

Compound	$\nu_{\text{SO}} \text{ cm}^{-1} (\text{calc.})^{(1)}$	$d_{\text{S-O}} \text{ \AA} (\text{calc.})^2$	$d_{\text{S-O}} \text{ \AA} (\text{obs.})^{(3)}$
$\text{S}_2\text{O}$	1165 (312)	1.46	1.47 (316)
$\text{H}_2\text{NSO}_3\text{H}$	1180 (313)	1.45	(1.48 (317) (1.44 (318))
$\text{S}_2\text{O}_3^{2-}$	1080 (210)	1.48	1.48 (319)
$\text{SOBr}_2$	1121 (314)	1.47	1.45 (320)
$\text{SO}_2(\text{NH}_2)_2$	1254 (315)	1.43	(1.39 (321) (1.40 (322))
$(\text{Me}_2\text{SO})_2\text{SnCl}_4$	920, 905 (301)	1.56, 1.57	1.54 (323)
$(\text{Me}_2\text{SO})\text{BF}_3$	938 (301)	1.55	1.52 (323)

(1) calculated from equation (1)

(2) predicted from Fig. 14

(3) observed value



For compounds having bond lengths in the range 1.45-1.48Å agreement between predicted and observed values is particularly good. The results for compounds containing shorter ( $< 1.45\text{Å}$ ) and longer ( $> 1.50\text{Å}$ ) bonds are less satisfactory.

The relationship may be presented more conveniently if, instead of the frequency ( $\text{cm}^{-1}$ ), the wavelength ( $\mu$ ) of the absorption maximum is plotted against the bond length. In this case a straight line is obtained (Fig.15). Using the data reported by Gillespie and Robinson<sup>310</sup> in combination with that in Table 6, a least squares treatment leads to the relationship,

$$d_{\text{SO}} = 3.99 \cdot 10^{-2} (\mu_{\text{SO}}) + 1.111$$

where,  $\mu_{\text{SO}}$  is the wavelength of the absorption band expressed in microns, and  $d_{\text{SO}}$  is in Å.

The bond length in the sulphite ion is of interest. On the basis of the stretching frequencies<sup>181</sup>  $\nu_{\text{s}} \text{SO} = 737 \text{ cm}^{-1}$  and  $\nu_{\text{as}} \text{SO} = 807 \text{ cm}^{-1}$ . Gillespie and Robinson<sup>310</sup> predicted from Fig.14 an S-O distance of 1.65Å, and commented that the distance reported by Zachariassen and Buckely<sup>324</sup> (1.39Å) seemed in error. Using the more recent values<sup>207</sup> of  $\nu_{\text{s}} \text{SO} = 970 \text{ cm}^{-1}$  and  $\nu_{\text{as}} \text{SO} = 930 \text{ cm}^{-1}$  the distance predicted from Fig.15 is 1.53Å. Since Gillespie's and Robinson's prediction, S-O bond lengths have been reported for  $(\text{Ni}(\text{H}_2\text{O})_6)\text{SO}_3$ <sup>325</sup> of 1.45Å and for

$\text{Cu}_2\text{SO}_3 \cdot \text{CuSO}_3 \cdot 2\text{H}_2\text{O}$ <sup>326</sup> of 1.51Å. Only for the latter compound is the observed value in agreement with the predicted value of 1.53Å but the S-O distance in this compound may be affected by the close approach of the sulphur atom of the sulphite group and one of the copper atoms. It has been shown that the S-O stretching frequencies of the sulphur(IV) oxo-anions, including  $\text{SO}_3^{2-}$ , do not fit the linear  $\nu_{\text{S}}\text{SO}/\nu_{\text{AS}}\text{SO}$  relationship established by Robinson<sup>177</sup> but do fit a similar relationship (Fig.11.) It seems probable, therefore, that for these compounds the  $\mu_{\text{SO}} - d_{\text{SO}}$  relationship (Fig.15) will not be applicable, though there may well be a similar relationship which applies within this class of compounds. Unfortunately there is as yet insufficient structural data to test this hypothesis.

Gillespie and Robinson<sup>310</sup> have also demonstrated a linear relationship between stretching frequency and  $\angle\text{OSO}$  angle in  $\text{SO}_2$  compounds, though the correlation is not too well established since relatively little data were available. These authors have also discussed the problem of defining the bond order of sulphur-oxygen bonds and have suggested that there exists a <sup>non</sup>linear relationship between the <sup>bond length</sup>~~force-constant~~ and the bond order. That the bond order-bond length relationship for C-C bonds is also non-linear is thought to support the latter suggestion. On the other hand Cruickshank<sup>322</sup>

has suggested that the bond order-bond length relationship for S-O compounds is rectilinear.

### Deformation Frequencies

The deformation frequencies of the oxo-anions have been mentioned above. For sulphur dioxide the single symmetric bending mode occurs<sup>327, 328</sup> at 520-530  $\text{cm}^{-1}$ , and for the trioxide the symmetric and asymmetric bending modes occur at  $\sim 495$  and  $\sim 530 \text{ cm}^{-1}$ , respectively<sup>329-331</sup>. The  $\gamma$  and  $\beta$  forms of  $(\text{SO}_3)_n$  have asymmetric bending modes at  $\sim 530$  and  $\sim 566 \text{ cm}^{-1}$  respectively<sup>322</sup>. Sulphuryl compounds  $\text{SO}_2\text{X}_2$  and  $\text{SO}_2\text{XY}$  give rise to an  $\text{SO}_2$  scissoring bend and an  $\text{SO}_2$  rocking vibration; the values reported for a series of compounds,<sup>315, 333-335</sup> fall in the range 520-610 and 530-620  $\text{cm}^{-1}$  respectively. Fairheller and Katon<sup>336</sup> from a study of several sulphones concluded that of the four  $\text{SO}_2$  bending vibrations only the  $\text{SO}_2$  scissoring (545-610  $\text{cm}^{-1}$ ) and wagging (496-525  $\text{cm}^{-1}$ ) are sufficiently localised to be of value as group frequencies. Bands in the region 500-570  $\text{cm}^{-1}$  have been assigned to bending modes in the alkali methyl sulphonates<sup>337</sup> and methyl sulphonic acid and its anhydride<sup>338</sup>. For the sulphamic acid<sup>339</sup> the symmetric and asymmetric bending modes occur at 640 and 511  $\text{cm}^{-1}$ , respectively and in sulphamates<sup>339</sup> bands at 520-560  $\text{cm}^{-1}$  are assigned to  $\text{SO}_3$  deformations.

## B. SULPHUR-NITROGEN BONDS

### Introduction

The infrared and Raman spectra of compounds containing sulphur-oxygen bonds have been extensively studied and various empirical correlations established<sup>176-178,180,310</sup>. Robinson<sup>177</sup> has shown that for sulphuryl compounds a linear relationship exists between the symmetric and asymmetric S-O stretching frequencies. Gillespie and Robinson<sup>310</sup> have related the S-O stretching frequencies of both thionyl and sulphuryl compounds to the S-O bond lengths and force constants, and these same authors<sup>180</sup> have demonstrated a linear correlation between the symmetric stretching and bending modes of the SOS group in  $X_nSOSX_n$  molecules and the square root of the mass of the groups  $SX_n$  attached to the oxygen atom. No such correlations appear to have been established for sulphur-nitrogen bonds. Since the nature of the bonding in sulphur-oxygen and sulphur-nitrogen systems is analogous, similar relationships might be expected to hold. In this section the available data are summarised and it is shown that there exists a linear relationship between the bond lengths and the wave-lengths of the absorption bands of sulphur-nitrogen bonds. Also, in the case of compounds containing the NSO group it is shown that the symmetric and asymmetric NSO stretching frequencies are linearly related.

### Discussion

The reported infrared and Raman data are summarised in Table 7. Since bond orders of up to three may occur a considerable range of frequency is observed ( $630-1690\text{ cm}^{-1}$ ); as expected the frequency increases with increasing bond order. Bond length measurements<sup>340</sup> show that for compounds which contain a formal sulphur-nitrogen single bond (e.g.  $\text{S(NSO)}_2$ ,  $\text{SO}_2(\text{NH}_2)_2$ ,  $\text{H}_3\overset{\ddagger}{\text{N}}.\text{SO}_3^-$  and  $\text{SO}_3(\text{N}_2\text{O}_2)^{2-}$ ) the experimentally determined bond distance varies over the range  $1.58-1.79\text{\AA}$ . Small variations in the bond distance are to be expected, e.g. as a result of variations in the character of the orbitals used in forming the bond. These variations will arise with change in the sulphur valency state and with changes in the number and nature of the groups attached to the sulphur and the nitrogen atoms. However, these factors are insufficient to account for the magnitude of the observed variations and several workers<sup>341-344</sup> have attempted to explain the observed bond lengths by assigning to the bond some  $\pi$  character, as a result of  $p_\pi-d_\pi$  overlap involving the lone pair electrons of the neutral nitrogen atom and the empty 3d orbitals of the sulphur atom. The observed stretching frequencies may also be explained in terms of this hypothesis.

Table 7

Correlation table for sulphur-nitrogen stretching frequencies

Compound type	$\nu_{SN}(\text{cm}^{-1})$
Alkyl thionitrites <sup>349</sup>	620-640
Sulphamic acid <sup>339, 348</sup>	682
$R_3P=NSO_2R'$ <sup>378</sup>	760-790
Cyclic $S_n(NR)_{8-n}$ compounds <sup>350-356</sup>	770-840
Sulphamates <sup>339</sup>	788
$R_2S=NCCHX_2$ (X=Cl, Br) <sup>366</sup>	800-825
Sulphonamides <sup>358-361</sup>	800-920
Sulphamides <sup>362-364</sup>	900-930
SN (short lived) <sup>379</sup>	1204
(SN) <sub>X</sub> polymer <sup>379</sup>	1225, 1015
$RN=S(F)CF(CF_3)_2$ <sup>372</sup>	1272-1279 or 1295-1300 *
$PhN=S(OMe)_2$ <sup>372</sup>	1283
$RN=SF_2$ <sup>374, 375</sup>	1350-1400
$NSF^{104}$	1372
$(RN=)_2SF_2$ <sup>380</sup>	1404-1428
$MeN=SOF_2$ <sup>365</sup>	1493
$NSF_3^{104}$	1515
$NS(F)_2NEt_3$ <sup>367</sup>	1515
$F_3SN.BF_3$ <sup>368</sup>	1690

\* see text for preferred assignment

Since a formally single sulphur-nitrogen bond may exist in widely different chemical environments with consequential variation in bond strength, any use of the term 'single bond' is necessarily ambiguous to some extent. Accordingly we shall use the term to describe all covalent bonds (including coordinate bonds) where  $\pi$  contributions make a relatively small contribution to the bond energy. Such single bonds will be expected to have a bond distance close to the value of  $1.74\text{\AA}$  which is obtained both from the sum of the Pauling tetrahedral covalent radii<sup>345</sup> and from the Schomaker-Stevenson equation<sup>346</sup>.

Examination of the data in Table 7 shows that the absorption range associated with each formal bond type (single, double, triple) is broad. Thus compounds containing a sulphur-nitrogen single bond may absorb over the range  $680\text{-}930\text{ cm}^{-1}$ , and it will be seen that increases in absorption frequency can generally be attributed to a strengthening of  $p\pi\text{-}d\pi$  interactions.

The observed bond length<sup>347</sup> in sulphamic acid ( $1.76\text{\AA}$ ) is close to the calculated value of  $1.74\text{\AA}$  which suggests that in this compound little or no  $p\pi\text{-}d\pi$  bonding occurs. Sulphamic acid exists as the zwitterion  $\text{H}_3\overset{+}{\text{N}}\text{-}\overset{-}{\text{SO}}_3$  so that the nitrogen lone pair is utilised in bonding the proton of the  $\text{H}_3\overset{+}{\text{N}}$ -group and so

is unavailable for donation to the sulphur 3d orbitals. Hence the sulphur-nitrogen bond is essentially restricted to two  $\sigma$ -electrons only. The observed stretching frequency 339, 348 ( $\nu_{\text{SN}} = 682 \text{ cm}^{-1}$ ) may, therefore, be taken as being close to that expected for a sulphur (VI)-nitrogen single bond.

The reported stretching frequencies<sup>349</sup> for the alkyl thionitrites ( $\text{RSNO}$ ,  $\nu_{\text{SN}} = 630 \text{ cm}^{-1}$ ) suggest that these compounds contain a sulphur (II)-nitrogen single bond. However, these absorption bands were not directly observed, the frequencies were calculated from those of combination bands.

For other compounds which formally contain a sulphur-nitrogen single bond, e.g., the sulphamate ion, the cyclic sulphur imines, sulphonamides and sulphamides, the observed stretching frequencies are higher than that of sulphamic acid (Table 7). In the sulphamate ion<sup>341</sup> the observed bond length (1.60Å) suggests some double bond character and, in agreement with this, the observed stretching frequency<sup>339</sup> ( $\nu_{\text{SN}} = 780 \text{ cm}^{-1}$ ) is considerably higher than that of the free acid. The cyclic imines<sup>350-356</sup>  $\text{S}_n(\text{NR})_{8-n}$ ,  $\text{R}=\text{H}$ ,  $\text{CH}_3$ , absorb in the range 770-840  $\text{cm}^{-1}$ ; when  $\text{R}=\text{CH}_3$  the absorption occurs towards the lower end of this range. Splitting of the band into two components may occur if the-NR groups are sufficiently close together<sup>356</sup>. The extent of  $\pi$ -bonding in these compounds is expected to be small



since the d-orbitals of the unsubstituted sulphur (II) atoms will be of relatively high energy. In the case of the sulphonamides the presence of electronegative substituents causes contraction of the sulphur 3d orbitals<sup>357</sup> so that the extent of  $p_{\pi}-d_{\pi}$  overlap is increased and accordingly the stretching frequency<sup>358-361</sup> occurs at 800-920  $\text{cm}^{-1}$ . The bonding in sulphamide has been discussed by Cruickshank<sup>322</sup> who has shown that sulphur-nitrogen  $\pi$ -bonding occurs to a considerable extent; the symmetric and asymmetric  $\text{SN}_2$  stretching modes occur<sup>362-364</sup> in the range 900-930  $\text{cm}^{-1}$ .

Compounds formally containing a sulphur-nitrogen double band may absorb over the very wide range, 780-1500  $\text{cm}^{-1}$  (Table 7), the frequency at which a given compound absorbs being apparently very sensitive to the nature of substituents on both the sulphur and the nitrogen atoms. If the bond is described of  $\sigma$  and  $\pi$  components then the observed variation in frequency may be considered to reflect changes in the  $\pi$ -bond order, and in the relative s, p and d character of the orbitals utilised in the  $\sigma$ -bond. Both of these factors will be subject to electronic effects by the substituents though, in general, the variation in the  $\pi$ -bond order will be the more important. For the greater number of compounds studied, the stretching frequency falls in the much more restricted range 1350-1430  $\text{cm}^{-1}$ .

The value of  $\nu_{\text{SN}} = 1493 \text{ cm}^{-1}$  reported<sup>365</sup> for  $\text{CH}_3\text{NSOF}_2$  is particularly high and is in fact greater than the frequency reported<sup>104</sup> for NSF ( $\nu_{\text{SN}} = 1372 \text{ cm}^{-1}$ ) which formally contains a sulphur-nitrogen triple bond. For compounds of the type<sup>366</sup>  $\text{R}_2\text{S}=\text{NCOX}$  ( $\text{X} = -\text{CHCl}_2, -\text{CHBr}_2, \text{R} = \text{alkyl, aryl}$ )  $\nu_{\text{SN}}$  is found at  $780\text{--}820 \text{ cm}^{-1}$  which suggests that in these compounds the sulphur-nitrogen bond is very nearly single in character. It has been suggested<sup>366</sup> that this situation arises as the result of polar SN and CO bonds in a strongly conjugated SNCO bonding system. It seems, therefore, that compounds which formally contain a sulphur-nitrogen double bond may in fact contain bonds varying in character between nearly single and nearly triple bonds. This situation presumably arises because of the ready polarisability of the  $\pi$ -component of the double bond.

Few compounds containing sulphur-nitrogen triple bonds are reported. For both<sup>104</sup>  $\text{NSF}_3$  and<sup>367</sup>  $\text{NS}(\text{F}_2)\text{NEt}_2$   $\nu_{\text{SN}}$  is assigned at  $1515 \text{ cm}^{-1}$ ; in the case of the former compound Richert and Glemser<sup>104</sup> have calculated the bond order of the sulphur-nitrogen bond as 2.7. In the case of NSF the observed frequency ( $\nu_{\text{SN}} = 1372 \text{ cm}^{-1}$ ) suggests that the bond order (2.5) is less than that in  $\text{CH}_3\text{NSOF}_2$  for which  $\nu_{\text{SN}} = 1493 \text{ cm}^{-1}$ ,

corresponding <sup>44</sup> to a bond order of  $\sim 2.6$  for the formally double bond if the vibration is predominantly a localised sulphur-nitrogen stretching mode. Coordination via the nitrogen atom of  $\text{NSF}_3$  has been found to shift the sulphur-nitrogen stretching mode to higher frequency. For  $\text{F}_3\text{SN.BF}_3$  Müller et.al.<sup>368</sup> find  $\nu_{\text{SN}}$  at  $1690 \text{ cm}^{-1}$ , so that  $\Delta \nu = 175 \text{ cm}^{-1}$ . A similar situation occurs with adducts of nitriles<sup>369,370</sup> though in these cases the frequency shifts are smaller ( $\Delta \nu \sim 25\text{-}110 \text{ cm}^{-1}$ ). Müller et.al.<sup>368</sup> attribute this increase in the sulphur-nitrogen stretching frequency to a real increase in the sulphur-nitrogen bond order.

Since, in general, the stretching frequencies of sulphur-nitrogen bonds increase with increasing bond order, i.e. as the bond strengthens and shortens, a relationship between stretching frequency and bond distance might be expected. There are relatively few compounds for which both stretching frequencies and bond lengths of the sulphur-nitrogen bond are available. The available data which are collected in Table 8 and illustrated graphically in Fig.16 show that there is a linear relationship between the wavenumbers of the absorption bands and the bond lengths of sulphur-nitrogen bonds. A least squares treatment of the data (ignoring that for potassium sulphamate) leads to

FIG 16

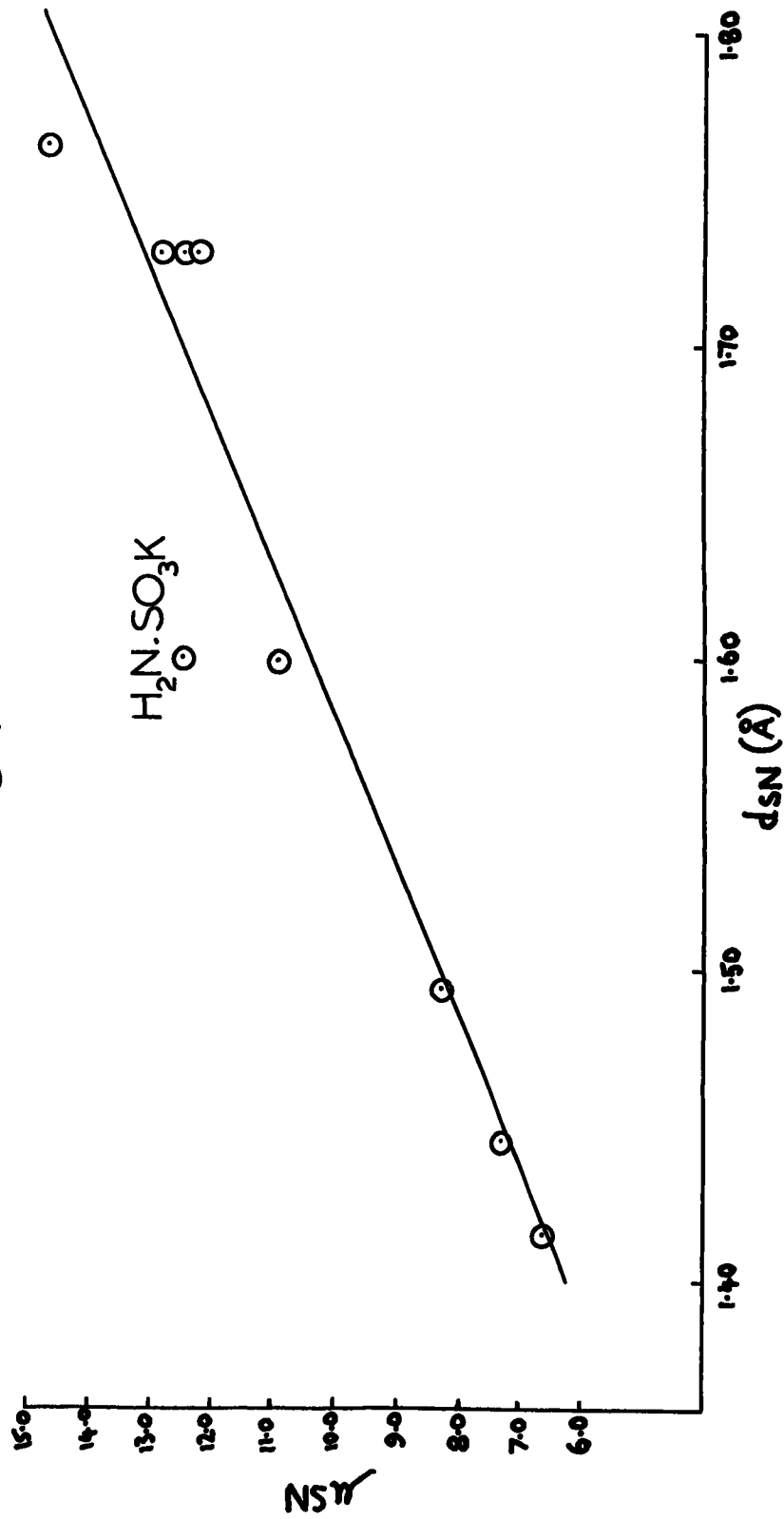

CORRELATION BETWEEN WAVELENGTHS ( $\mu$ ) AND BOND DISTANCES ( $d$ )  
OF S-N BONDS

the relationship,

$$d_{\text{SN}} = 0.0483 \left( \frac{\mu}{\text{SN}} \right) + 1.099$$

where,  $\mu_{\text{SN}}$  is the wavelength of the absorption band expressed in microns and  $d_{\text{SN}}$  is in Angstrom units.

Table 8

Stretching frequencies ( $\nu_{\text{SN}}$ ) and bond lengths ( $d_{\text{SN}}$ )

in some sulphur-nitrogen compounds

Compound	$\nu_{\text{SN}}$ $\text{cm}^{-1}$	$\mu$	$d_{\text{SN}}$ (Å)
$\text{H}_3\text{N.S}\bar{\text{O}}_3$	682 (339, 348)	14.66	$1.764 \pm 0.020$ (347)
$1.4\text{S}_6(\text{NH})_2$	780, 819 (356)	12.21, 1282	1.73 (381)
$\text{H}_2\text{N.S}\text{O}_3\text{K}$	805 (339)	12.42	$1.60 \pm 0.03$ (341)
$\text{S}_7\text{NH}$	806 (356)	12.41	1.73 (382)
$\text{SO}_2(\text{NH}_2)_2$	915 (362)	10.93	$1.600 \pm 0.009$ (343)
NS (short lived)	1204 (379)	8.31	1.495 (383)
NSF	1372 (104)	7.29	1.446 (104)
$\text{NSF}_3$	1515 (104)	6.60	1.416 (104)

The existence of this correlation implies that for the compounds considered an essentially pure sulphur-nitrogen

stretching vibration occurs. It is of interest to note that if the frequency of the absorption band, expressed in wave numbers, is plotted against the bond length then the points representing the various compounds fall upon a smooth curve of similar shape to that reported by Gillespie and Robinson<sup>310</sup> for SO bends. Further, if for the compounds reported by Gillespie and Robinson<sup>310</sup> the wavelength of the absorption band is plotted against bond length then a linear relationship is observed. The value of  $\nu_{SN}$  for sulphamide used in Fig.16 was calculated as the arithmetic mean of the symmetric and asymmetric  $SN_2$  stretching vibrations. Gillespie and Robinson<sup>310</sup> have discussed the assumptions implicit in this treatment. The scatter in the points is never greater than  $0.04\text{\AA}$  and is less than this for bonds shorter than  $1.70\text{\AA}$ . Fig.16 may be used to predict sulphur-nitrogen bond distances in compounds for which these have not been measured. Thus, for the compounds,  $1.5 S_6(NCH_3)_2$ ,  $F_5S.NH_2$ ,  $CH_3N.(SO_2NH_2)_2$ ,  $C_6H_5NS(OCH_3)_2$  and  $NS(F_2)NC_2H_5$  the sulphur-nitrogen stretching frequency has been assigned at 13.00, 12.89, 11.11, 7.79 and 6.60 respectively<sup>354</sup>, 371, 363, 372, 369 corresponding to bond distances of 1.72, 1.72, 1.63, 1.48 and  $1.42\text{\AA}$ . The data for potassium sulphamate appears to be anomalous.

If the reported<sup>339</sup> stretching frequency results from a pure sulphur-nitrogen stretching vibration the bond distance is in error by about  $0.1\text{\AA}$ . However, the reported<sup>341</sup> bond distance ( $1.60\text{\AA}$ ) corresponds to a high degree of double bond character and it is possible that coupling occurs between the sulphur-nitrogen and sulphur-oxygen vibrations. If so then anomalous behaviour is to be expected.

A knowledge of the manner in which stretching frequency varies with bond type enables the assignment of sulphur-nitrogen stretching frequencies for several compounds reported in the literature. For  $\text{F}_5\text{S.NH}_2$  Clifford and Duncan<sup>371</sup> have tentatively assigned a weak band at  $1208\text{ cm}^{-1}$  to  $\nu_{\text{SN}}$ . If this assignment is correct then the sulphur-nitrogen bond has a considerable double bond character whereas, on theoretical grounds an essentially single bond is to be expected. The present author favours assignment of the strong band at  $776\text{ cm}^{-1}$  (assigned by Clifford and Duncan to an NH deformation) to the sulphur-nitrogen stretching vibrations. Cohen et.al.<sup>373</sup> have reported the spectrum of  $\text{F}_5\text{S.NSF}_2$ ; bands at  $760\text{ cm}^{-1}$  and  $1320\text{ cm}^{-1}$  may be assigned to the sulphur-nitrogen single and double bands respectively. Compounds of the type  $\text{RN}=\text{S}(\text{F})\text{CF}(\text{CF}_3)_2$  have been studied by Dresdner et.al.<sup>372</sup> who suggest that for these compounds  $\nu_{\text{SN}}$  occurs in the range  $1272\text{--}1279\text{ cm}^{-1}$ . For the group  $-\text{N}=\text{SF}_2$

the normal absorption range<sup>374, 375</sup> is 1350-1400  $\text{cm}^{-1}$  and replacement of one F atom by the  $-\text{CF}(\text{CF}_3)_2$  group might be expected to lower  $\nu_{\text{SN}}$  by only a small amount. The present author favours assignment of the strong band at 1295-1300  $\text{cm}^{-1}$  to  $\nu_{\text{SN}}$  for these compounds.

#### Compounds containing the NSO group

Compounds containing the NSO group give rise to absorptions which are conventionally described as symmetric and asymmetric NSO

Table 9

Symmetric ( $\nu_{\text{g}}$ ) and asymmetric ( $\nu_{\text{as}}$ ) stretching frequencies of -NSO compounds.

Compound type	$\nu_{\text{g}}$ ( $\text{cm}^{-1}$ )	$\nu_{\text{as}}$ ( $\text{cm}^{-1}$ )
RNSO (376)	1120-1135	1238-1252
ArNSO (384)	1137-1179	1272-1300
ArSO(NH)NMe <sub>2</sub> (385)	1135-1160	1260-1270
ArSO(NH)OPh (385)	1160	1295
R <sub>2</sub> SO(NH) (385)	1099	1212
(NSOF) <sub>n</sub> (386)	1250	1351
RNSOF <sub>2</sub> (365, 387)	1219-1320	1428-1492

stretching vibrations. The positions and relative intensities of these vibrations for the aliphatic N-sulphinyl compounds<sup>376, 377</sup> are similar to those observed for SO<sub>2</sub>, which



FIG 17

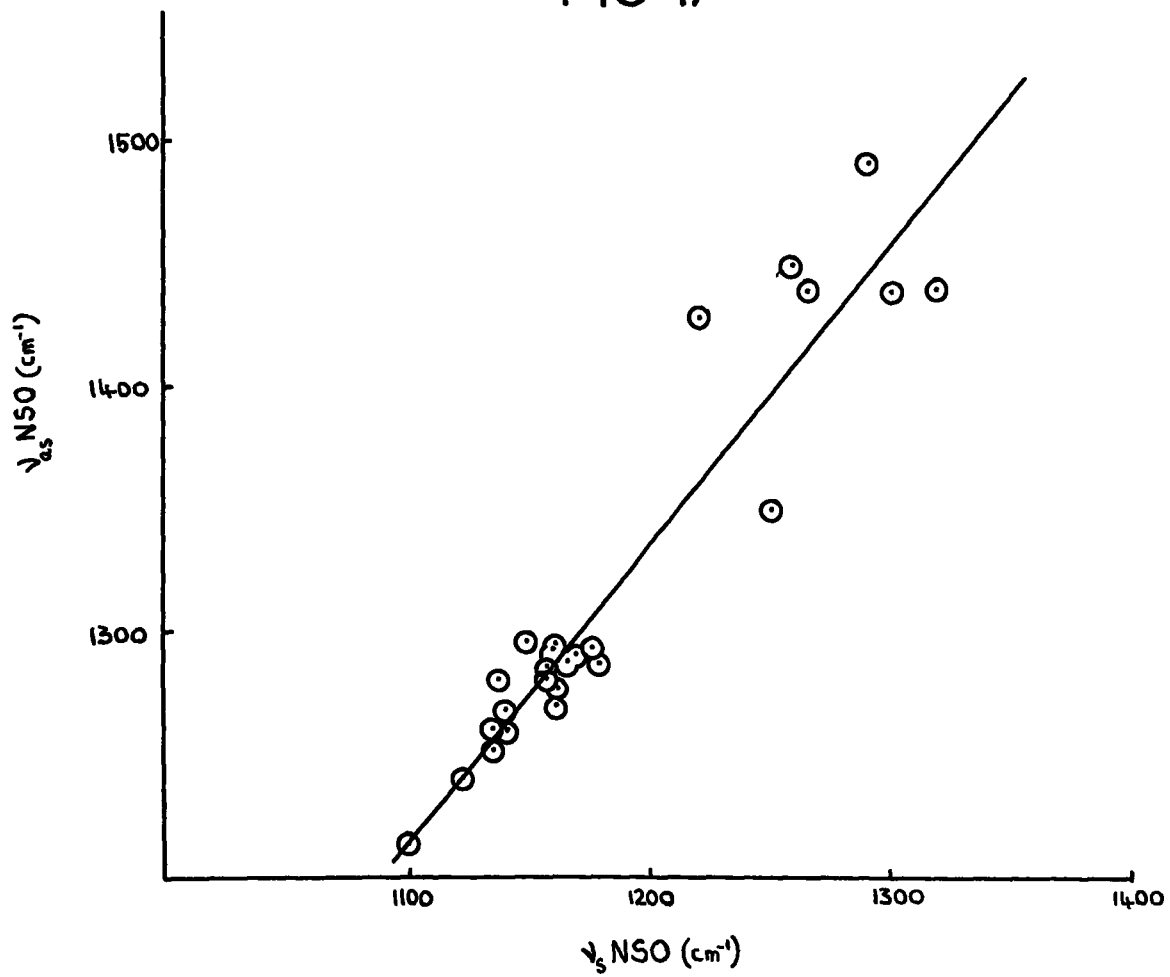

CORRELATION BETWEEN SYMMETRIC AND  
ASYMMETRIC NSO FREQUENCIES

suggests<sup>377</sup> a similarly angled structure for the NSO group. From measurements on N-sulphinyl methyl, ethyl and phenylamines Glass and Pullin<sup>376</sup> have calculated the angle between the NS and SO bands as about  $120^{\circ}$ . For both inorganic and organic sulphuryl compounds Robinson<sup>177</sup> has shown that there is a linear relationship between the symmetric and asymmetric SO stretching frequencies. A similar relationship might, therefore, be expected to hold in the case of NSO compounds. The available data are collected in Table 9 and Fig.17. Although rather limited the data are considered to show a satisfactorily linear relationship between the symmetric and asymmetric stretching vibrations.

## **EXPERIMENTAL**

(a) Apparatus and techniques

The Nitrogen Supply

As most of the compounds studied react rapidly with moist air almost all of the work was carried out in an atmosphere of dry nitrogen, either in a glove box or in apparatus so designed that counter-current techniques could be used. The nitrogen used for the counter-current work was dried by passage through two efficient traps cooled in liquid nitrogen.

The glove box

The glove box (Lintott III.B) was set up in such a way that its nitrogen atmosphere could be recycled, by means of a small pump inside the box, through two efficient traps cooled in a Dewar vessel containing liquid nitrogen. As a further precaution against traces of moisture trays of  $P_2O_5$  (frequently renewed) were kept in the box. The transfer tube to the glove box was thoroughly purged with nitrogen, also dried by passage through a trap immersed in liquid nitrogen, before the introduction of materials into the box.

Infrared spectroscopy

Infrared spectra over the range  $2.5-25\mu$  ( $4000-400\text{ cm}^{-1}$ ) were recorded on either a Grubb-Parsons GS.2A or Spectromaster prism-grating spectrophotometers. Far infrared spectra,

21-50 $\mu$  (475-200  $\text{cm}^{-1}$ ) were recorded on a Grubb-Parsons DM2/DM3 spectrophotometer.

Samples of moisture sensitive materials were prepared for spectroscopic analysis in the glove box. Most samples were prepared in the form of nujol mulls between potassium bromide, sodium chloride or caesium iodide plates. Where halogen exchange with the plates was possible, polythene sheets were inserted between the sample and the plates.

#### Mass spectra

Mass spectra were recorded on an A.E.I. (M.S.9) mass spectrophotometer. Most samples were mounted in the glove box, onto an inert ceramic, and introduced into the ion source using a direct insertion probe.

#### (b) The preparation and purification of starting materials and solvents

All solvents were purified and stored under an atmosphere of nitrogen.

A.R. benzene, A.R. toluene, hexane and heptane were dried by standing over sodium wire for several days.

Diethyl ether: dried initially over sodium hydroxide and finally over sodium wire.

Nitromethane and acetonitrile: distilled from  $\text{P}_2\text{O}_5$  and stored over anhydrous magnesium sulphate.

Dimethylsulphoxide: twice distilled from sodium hydroxide under reduced pressure.

Carbon tetrachloride: stored over phosphorus pentoxide.

Sulphamic acid: recrystallised from water at 75°C and dried under vacuum at 60°C.

A.R. phosphorus (V) chloride: used as obtained, all loading operations carried out in the glove box.

Triphenylphosphine; vacuum sublimed at 80°C. Triphenylarsine; recrystallised from ethyl alcohol and dried under vacuum. Triphenylstibine; used as obtained after prolonged pumping under high vacuum at room temperature.

p-Toluenesulphonamide; recrystallised from water and dried by prolonged pumping under high vacuum at 50-60°C.

m-Nitrobenzenesulphonamide; p-chlorobenzene-sulphonamide, p-methoxybenzenesulphonamide, benzenesulphonamide and pentafluorobenzenesulphonamide were dried by prolonged pumping under high vacuum at 50-60°C.

Thionyl chloride: fractionally distilled, first from quinoline and secondly from linseed oil. The fraction having b.pt. 76-78°C/760 mm. was collected.

Sulphuryl chloride: fractionally distilled, the fraction having b.pt. 69.0-69.5°C/760 mm. being collected.

Sodium azide, potassium thiocyanate, diphenyl sulphone,

hexamethylbenzene and mercuric chloride were all dried by prolonged pumping under high vacuum at room temperature.

Ammonium chloride: dried at 100°C for 48 hours and then pumped under high vacuum at room temperature for 8 hours.

Benzenesulphonyl chloride: dried by standing over anhydrous magnesium sulphate for several days.

Chlor-sulphonic acid and phosphorus oxychloride: fractionally distilled at atmospheric pressure immediately before use.

Niobium(V) chloride: heated under reflux with an excess of pure thionyl chloride, filtered and dried under vacuum.

Beryllium chloride: a pure, anhydrous sample was kindly provided by Mr.P.D.Roberts.

Diphenylamine: purified by vacuum sublimation at 0.01 mm and 60-80°C.

Trimethylamine: purified by vacuum distillation and stored over sodium hydroxide.

Pyridine and triethylamine: dried by standing over sodium hydroxide and fractionally distilled onto fresh sodium hydroxide. iso-Quinoline was similarly purified, the distillation being carried out under reduced pressure.

#### The preparation of sulphamide

(i) By the reaction between sulphuryl chloride and gaseous ammonia<sup>388</sup>

The ammonia was dried by passage through three 60 cm. columns

filled with, first, soda lime, secondly, potassium hydroxide and, finally, sodium wire.

Fractionally distilled sulphuryl chloride (25 ml.) was dissolved in dry petroleum ether (b.pt. 40-60°, 800 ml.) and cooled to 0°C in an ice/salt bath, with constant stirring. Anhydrous ammonia was added over the surface of the stirred solution at such a rate that the solution temperature was maintained between 0°-10°C. To give satisfactory contact between the reactants the rate of stirring was ~1200 r.p.m. Reaction was complete after 60 minutes. The crude product was warmed to room temperature, the solid material separated by filtration and dried under vacuum. This solid was dissolved in the minimum amount of dilute hydrochloric acid (100 ml. H<sub>2</sub>O/5 ml. conc. HCl), the solution warmed to 70-80°C for ten minutes, cooled to room temperature and the water removed by vacuum distillation. The solid product was desiccated over P<sub>2</sub>O<sub>5</sub> for 24 hours and Soxhlet extracted using A.R. acetone. Vacuum removal of the solvent gave crude sulphamide, 2g., ~8% yield. The reaction was repeated on three further occasions the maximum yield obtained being 12% based on sulphuryl chloride.

(ii) By the reaction between sulphuryl chloride and liquid ammonia<sup>24,25</sup>

Liquid ammonia (1000 ml.) was condensed into the reaction flask and cooled to -78°C in an acetone/dry ice bath. A solution



of sulphuryl chloride (100 ml.) in dry hexane (1000 ml.) was added over four hours with constant stirring at about 1000 r.p.m. Excess ammonia was allowed to evaporate overnight and the solid material separated by filtration and dried under vacuum. The crude product (210g.) was dissolved in water (500 ml.), acidified with concentrated HCl (25 ml.), warmed to 70-80°C for 10 minutes, cooled to room temperature and allowed to stand overnight. The solution was then evaporated to dryness under vacuum at 60-70°C and the product desiccated over  $P_2O_5$ . Extraction with A.R. acetone (3 x 400 ml.) followed by removal of the solvent under vacuum gave crude sulphamide, 70.5g., 62%. Recrystallisation from propanol gave pure sulphamide 58.5g., m.pt. 91-92°C.

Preparation of ammonium trisulphimide <sup>389</sup>

Sulphamide (6g.) placed in a filtration receiver tube, the side arm of which was lightly closed with cotton wool. The tube was heated in an oil-bath to about 100°C and, when all of the sulphamide had melted, the temperature was raised to 180°C over one hour. During the second hour the temperature was increased to 200-205°C and then maintained for four hours. After cooling to room temperature the product is obtained as a fused cake. Recrystallised three times from  $H_2O:EtOH, (1:3)$  and dried at 100°C. Found, S= 33.61; N=29.26; H=4.09, calculated for  $(SO_2N.NH_4)_3$ , S= 33.36; N=29.16; H= 4.20%.

Preparation of silver trisulphimide<sup>389</sup>

Ammonium trisulphimide (6g.) was dissolved in water (60 ml.) and the solution diluted with boiling water (1500 ml.) A solution of  $\text{AgNO}_3$  (12g.) in water (150 ml.) was then added, the solution boiled for a few minutes and filtered hot to remove a small amount of brown precipitate. On cooling the solution deposited needles of silver trisulphimide trihydrate which were removed by filtration and dried at  $100^\circ\text{C}$ .

The preparation of benzenesulphinic acid<sup>390</sup>

Benzenesulphonic acid (30g.) was dissolved in ether (150 ml.) containing a small volume (1.5ml.) of water. Zinc dust (30 g.) was then added at a rate such the solution was kept boiling briskly. This addition was completed over one hour and the system heated under reflux for a further hour. The precipitate was separated by filtration, washed twice with water and heated with an aqueous solution of sodium carbonate (30g./150 ml.) for one hour. After cooling and filtering the filtrate was neutralised with concentrated sulphuric acid. The solid product was separated by filtration and dried under vacuum at  $30^\circ\text{C}$ , m.pt.  $82-83^\circ\text{C}$  (reported,  $83-84^\circ\text{C}$ .)

The preparation of benzenesulphinyl chloride<sup>390</sup>

Benzenesulphonic acid (14.2g, 0.1 mole) was suspended in ether (100 ml.) and a slight excess (0.11 mole) of thionyl chloride

added over 20 minutes at room temperature, with constant stirring. Stirring at room temperature was continued for a further 45 minutes, the solution filtered to remove a small amount of solid and the ether and excess thionyl chloride removed under vacuum. The product, which crystallised on cooling, had m.pt. 33-36°C (reported, 38°C)

The preparation of benzenesulphenyl chloride <sup>391</sup>

Carbon tetrachloride (150 ml.) cooled with stirring to -10°C in an ice/salt bath. A slow stream of chlorine was passed through the solvent whilst a solution of thiophenol (6g.) in carbon tetrachloride (50 ml.) was added dropwise over 30 minutes. Excess chlorine and solvent were then removed under vacuum to leave a dark red liquid. Found, Cl=25.61%, calculated for  $C_6H_5SCl$ , Cl= 24.51%.

The preparation of NN diethylaminotrimethylsilane <sup>392</sup>

Trimethylchlorosilane (54g., 0.5 mole) was dissolved in dry ether (500 ml.) and the solution added over 1 hour to a well stirred solution of diethylamine (73 g., 1.0 mole) in dry ether (500 ml.). The precipitated amine hydrochloride was removed by filtration. The ether was removed from the filtrate under vacuum and the product distilled, the fraction collected had b.pt. 122-125°C, reported b.pt. 125-126°C.

The preparation of triphenylphosphine dichloride<sup>393</sup>

Triphenylphosphine (25g.) ground to a fine powder, slurried in dry hexane and cooled to  $-5^{\circ}\text{C}$  in an ice/salt bath with constant stirring. A steady stream of chlorine, dried by passage through concentrated sulphuric acid, was passed over the surface of the stirred suspension. The gas flow rate was so adjusted that the gas was completely absorbed by the suspension, and the temperature was maintained at  $0^{\circ}$  to  $-5^{\circ}\text{C}$ . After two hours a yellow colour, due to the presence of excess chlorine, rapidly developed. The gas flow was discontinued and excess chlorine immediately removed at a water pump. Evaporation to dryness in vacuo gave a moist, yellow solid. Whilst the yellow colour was presumably due to traces of entrapped chlorine hard pumping under high vacuum had little apparent effect. The solid was washed with 100 ml. of benzene/chloroform mixture (1:1<sup>v/v</sup>) to give an insoluble white solid and a yellow solution. This mixture was pumped under vacuum until the yellow colour had disappeared, after which evaporation to dryness gave a clean, white solid. This solid was washed with benzene (3 x 20 ml.) and dried under vacuum. Found, Cl=22.00%, calculated for  $(\text{C}_6\text{H}_5)_3\text{PCl}_2$ , Cl = 21.28%. The infrared spectrum of this compound contained bands at, 1586m, 1488 ms, 1441s, 1370ms, 1342w, 1316m, 1261m, 1181w, 1153w, 1122s, 1110s, 1095s, 996m, 939m, 939w, 868w, 761s, 748s, 728s, 697sh, 691s, 656m, 616m, 585s, 537s, 517s, 494m, 452sh, 444m.

The preparation of sulphanic chloride(i) The preparation of trichlorophosphazosulphuryl chloride<sup>13</sup>

A.R. phosphorus pentachloride (426.9g., 2.05 mole) was pulverised in a glove box and loaded into the reaction flask. The requisite amount of sulphamic acid (97.1g., 1.0 mole) was then added, outside the glove box, against a counter-current of nitrogen. Anhydrous carbon tetrachloride (50 ml.) was added to the mixture and the whole heated in an oil-bath at 110-120°C. Evolution of hydrogen chloride began almost immediately. Within 30 minutes the mixture began to liquefy, and liquefaction was complete after 2½-3 hours. The reaction mixture was then cooled and filtered to remove small amounts of unchanged sulphamic acid. Vacuum distillation removed, first, the carbon tetrachloride at room temperature, and secondly, the phosphorus oxychloride at 40-60°C. Finally the product was pumped under vacuum at 90°C to remove the last traces of the oxychloride and any unchanged phosphorus(V) chloride. On cooling and filtering the trichlorophosphazosulphuryl chloride was obtained as a colourless crystals, m.pt. 32-34°C; reported 35-36°C. Recrystallisation from carbon tetrachloride raised the m.pt. to 35-36°C. The infrared spectrum contained bands at, 1745m, 1639w, 1538m, 1370vs, 1204vs, 1170sh, 766s, 720w, 621sh, 601s, 572m, 535wm, 503s.

(ii) The pyrolysis of trichlorophosphazosulphuryl chloride<sup>118</sup>

Trichlorophosphazosulphuryl chloride (250.9g., 1.0 mole) was placed in a two necked flask fitted with a 30 cm Vigreux column and an inlet tube for dry nitrogen. A condenser attached to the top of the Vigreux column lead to a receiver cooled to about  $-20^{\circ}\text{C}$  in an acetone/dry ice bath. The system was evacuated and the nitrogen flow rate so adjusted that the internal pressure was maintained at 2-5 mm.Hg. The flask was heated in an oil bath to  $140-150^{\circ}\text{C}$ ; the evolution of phosphorus oxychloride which was initially slow became more rapid after about 20-30 minutes. The oil bath was maintained at  $140-150^{\circ}\text{C}$  for two hours and then heated to  $160-170^{\circ}\text{C}$  for 30 minutes. A total of 142g. of phosphorus oxychloride was recovered, corresponding to a conversion of about 92% of the starting material.

The crystalline residue was filtered in air and well pressed out on the frit. The solid obtained was mixed with ice water (150 ml.) to remove readily hydrolysable impurities and then the mixture was warmed to  $15^{\circ}\text{C}$  for 10 minutes. After filtration the solid obtained was desiccated over phosphorus pentoxide for 24 hours. Recrystallisation from ten times its own weight of heptane gave fairly pure  $\alpha$ -sulphanuric chloride (23.g.,  $\sim 24\%$  yield) which was further purified by sublimation at  $120^{\circ}\text{C}$  and 0.01mm Hg.

The filtrate left after removal of the crude  $\alpha$ -isomer was extracted with several portions of hot heptane. The bulk of the solvent was removed under vacuum after which cooling of the solution to  $0^{\circ}$  to  $-5^{\circ}\text{C}$  gave crystals of the crude  $\beta$ -sulphanuric chloride. After filtration the  $\beta$ -isomer was purified at  $40^{\circ}\text{C}$  and 0.01 mm.Hg.

The preparation of the pyridine-sulphur trioxide complex<sup>394</sup>

Pyridine (12.4g.) was dissolved in dry chloroform (70ml.) and the solution cooled to  $-10^{\circ}\text{C}$  in an ice-salt bath. Freshly distilled chlorosulphonic acid (7.7g) was added with constant stirring and shaking at such a rate that the temperature remained in the range  $0^{\circ}$  -  $5^{\circ}\text{C}$ . The resulting slurry was maintained at about  $0^{\circ}\text{C}$  for one hour, the solid separated by filtration washed with dry, ice-cold, chloroform (3 x 10 ml) and dried under vacuum. Found, C = 37.8, H = 3.0%; calculated for  $\text{C}_5\text{H}_5\text{N}\cdot\text{SO}_3$ , C = 37.7, H = 3.2%. The infrared spectrum contained bands at, 3125s, 3086m, 3058w, 2915w, 1631m, 1613s, 1577w, 1529m, 1477m, 1462s, 1426w, 1385w, 1304;1299 vs (doublet) 1269m, 1232m, 1156m, 1099w, 1075vs, 1062m, 1043ms, 1031w, 1017ms, 879w, 844w, 781s, 753m, 685vs, 676s, 599vs, 561s.

The complex was dissolved in dry acetonitrile and on standing at room temperature the solution slowly deposited needle-like crystals. These were separated by filtration and dried under vacuum. Found, C = 36.82; H = 3.64; N = 8.43; S = 19.41%.

$C_5H_5N.SO_3$  requires, C = 37.73; H = 3.17; N = 8.80; S = 20.41%.

The infrared spectrum contained bands at, 3178m, 3106sh, 3067m, 1639sh, 1616s, 1536s, 1490s, 1342sh, 1274vs, 1220sh, 1190s, 1170sh, 1086s, 1058s, 1038vs, 1011ms, 919ms, 889sh, 858w, 784vs, 795vs, 731vs, 681vs, 652w, 613s, 588sh, 575vs, 506ms.

The preparation of the pyridine-selenyl chloride complex<sup>395</sup>

Selenyl chloride (3.32g., 0.01 mole) was dissolved in dry chloroform (30 ml.) and the solution cooled to 0°C in an ice-salt bath. Pyridine (1.58g., 0.02 mole) was added dropwise, with rapid stirring, over 10 minutes. A white precipitate formed immediately. Dry toluene (20 ml) was added to give a heavy slurry, the solid separated by filtration, washed with dry chloroform (3 x 20 ml) and dried under vacuum. Found, C = 37.10; H = 3.02; Cl = 22.24% calculated for  $SeOCl_2 \cdot 2(C_5H_5N)$ , C = 37.06; H = 3.11; Cl = 21.89%. The infrared spectrum contained bands at, 3086m, 3058m, 3021m, 2994w, 1919w, 1880w, 1848w, 1694w, 1634m, 1597vs, 1572w, 1447s, 1449vs, 1351wm, 1250m, 1203s, 1155s, 1058vs, 1030vs, 1006vs, 920vs, 879s, 762vs, 746sh, 699sh, 682vs, 634vs, 621sh, 590ms, 423ms, 329s, 298s, ~220s (very broad).

The preparation of pyridine hydrochloride

Hydrogen chloride gas was dried by passage through concentrated sulphuric acid and passed into a cooled solution of pyridine in dry ether. The precipitated hydrochloride was washed several times with ether and dried under vacuum. Found, Cl = 31.10%; calculated for  $C_5H_5N.HCl$ , Cl = 30.8%.



(c) Attempted synthesis of the sulphauric system(i) The reaction between ammonium trisulphimide and thionyl chloride

Ammonium trisulphimide (2.88g., 0.01 mole) slurried with excess thionyl chloride (5.5ml.) and heated under reflux at 85-95°C for 6 hours. Cooled to room temperature. The solid material was separated by filtration, washed with dry hexane (3 x 10 ml.) and dried under vacuum. The m.p. and infrared spectrum of this material were identical with those of the starting material.

The reaction was repeated as above but with 10 drops of dimethylformamide added and the product was recrystallised from H<sub>2</sub>O:EtOH (1:3). The purified compound decomposed at ~200°C, with the evolution of ammonia. The infrared spectrum of this compound contained bands at, 3175s, 3030sh, 2845sh, 1626w, 1404s, 1253m, 1190m, 1117sh, 1081s, 1018m, 860m, 781w, 612s, 595sh, 550w, 532m. The infrared spectrum of the starting material was very similar and contained bands at, 3425sh, 3175vs, 3030sh, 2841sh, 1634wm, 1404s, 1242s, 1217sh, 1143s, 1081s, 1047s, 825s, 760w, 672 and 667m (doublet) 595sh, 575s.

(ii) The reaction between silver trisulphimide and thionyl chloride

Silver trisulphimide trihydrate (3.06g., 0.005mole) treated, at room temperature, with an excess of thionyl chloride (2 ml.)

After the initial reaction due to dehydration had occurred the mixture was heated under reflux at 85-95°C for 3 hours. The system was cooled to room temperature and the residual precipitate separated by filtration, washed with thionyl chloride (2 x 2ml) then with toluene (3 x 5 ml.) and dried under vacuum. Found, Cl = 25.1% calculated for AgCl, Cl = 24.8%. This material was completely transparent in the infrared region. Evaporation of the filtrate to dryness under vacuum gave a red-brown oil, insoluble in hexane, toluene, carbon tetrachloride and ether, slightly soluble in anhydrous ethyl alcohol. The infrared spectrum of this oil contained bands at, 3426s, 3401s, 3322s, 3289s, 3205s, 1610w, 1527wm, 1379sh, 1348vs, 1307w, 1179sh, 1147vw, 957vw, 889s, 741w, 617w, 576m, 534s.

(ii) The reaction between thionyl chloride and sodium azide

To sodium azide (6.5g., 0.1mole) was added a solution of thionyl chloride (11.9g., 0.1mole) in dry benzene (50ml) and the mixture heated under reflux at 85-95°C for six hours. The residual solid was separated by filtration and the filtrate vacuum distilled to remove benzene and unchanged thionyl chloride. The residue from the distillation was a very small amount of a dark red-brown, viscous oil which was not investigated further.

The reaction was repeated in the absence of solvent and worked up as above. Again only traces of a red-brown, viscous oil were obtained.

(iv) The reaction between benzenesulphinyl chloride and sodium azide

Benzenesulphinic acid chloride (1.6g., 0.01 mole) and sodium azide (0.65, 0.01 mole) were heated under reflux at 110-120°C for 6 hours. After cooling to room temperature the mixture was filtered and the filtrate was shown by infrared spectroscopy to be unchanged benzenesulphinylchloride.

(v) The reaction between benzenesulphenyl chloride and sodium azide

Benzenesulphenyl chloride (1.4g., 0.01 mole) and sodium azide (0.65g., 0.01 mole) were heated under reflux at 130-140°C for 8 hours. After cooling to room temperature the mixture was allowed to stand for 48 hours. The solid residue was separated by filtration. The filtrate, a red liquid, was shown by infrared spectroscopy to be unchanged benzenesulphenylchloride.

(vi) The reaction between p-toluenesulphonamide and sulphamic acid

p-Toluenesulphonamide (3.42g., 0.02 mole) and sulphamic acid (2.91g., 0.03 mole) were mixed together and heated at 190-205°C for 16 hours. After cooling to room temperature the reaction residue was extracted with benzene (2 x 15 ml). Removal of the solvent under vacuum gave a very small amount of a cream coloured solid, m.pt. ~ 80°(dec), the infrared spectrum of which bore no resemblance to that of sulphanuric chloride.

(vii) The reaction between thionyl chloride and ammonium chloride

Ammonium chloride (5.4g., 0.1 mole) and thionyl chloride (47.6g., 0.4 mole) were mixed together and heated at 90-95°C for 22 hours. After cooling to room temperature the solid residue was separated by filtration, washed with hexane (3 x 10 ml.) and dried under vacuum (5.3g.) The infrared spectrum of this solid contained only bands due to the  $\text{NH}_4^+$  ion.

(viii)(a) The reaction between p-toluenesulphonamide and phosphorus(V) chloride 396

p-Toluenesulphonamide (30.1g., 0.175 mole) and A.R. phosphorus(V) chloride (36.6g., 0.175 mole) were well mixed and dry carbon tetrachloride (20 ml.) added. The mixture was heated in an oil bath at 100-110°C. Evolution of hydrogen chloride began immediately and the mixture began to liquefy after about 15 minutes. After heating for one hour the solution was allowed to cool to 40-50°C and the solvent was removed under vacuum. The liquid product was heated, under vacuum, at 90-100°C for 15 minutes to remove any unchanged phosphorus(V) chloride. On cooling the product solidified and was recrystallised from carbon tetrachloride. Found, C = 27.63; H=2.43; Cl=35.20%; calculated for  $\text{CH}_3\cdot\text{C}_6\text{H}_4\text{SO}_2\text{N}:\text{PCl}_3$ , C = 27.41; H = 2.30; Cl= 34.71%. m.pt., 105-106°C, reported 106°C. The infrared spectrum of this compound contained bands at, 3049s, 2967s, 2916s, 2865w, 2463m, 2404m, 2299w, 2242w, 1961m, 1923m, 1811w, 1757w, 1656w, <sup>1595m</sup>1492m, 1451sh, 1447vs, 1399w,

1379w, 1316s, 1300s, 1258m, 1202s, 1150vs, 1117m, 1087s, 1043sh, 1017m, 953w, 846m, 812s, 800ms, 762s, 729sh, 705m, 670m, 621s, 590s, 560ms, 515m, 505m.

(b) Pyrolysis of the product,  $\beta$ -tolytrichlorphosphazosulphone

$\beta$ -Tolytrichlorphosphazosulphone (30.7g., 0.1 mole) was placed in a two necked flask fitted with a 30 cm Vigreux column and an inlet tube for dry nitrogen. A condenser attached to the top of the Vigreux column lead to a receiver cooled to about  $-20^{\circ}\text{C}$  in an acetone/dry ice bath. The system was evacuated and the nitrogen flow rate so adjusted that the internal pressure was maintained at 2-5mm.Hg. The flask was then heated in an oil bath to  $190-200^{\circ}\text{C}$ .

After about 3 hours the slow distillation of a very pale yellow liquid began; the temperature of the vapour was  $36-38^{\circ}\text{C}$ . This distillation continued for about 1 hour, the residue in the distillation flask becoming progressively more viscous during this time. When distillation seemed complete the compound was allowed to cool to room temperature under an atmosphere of nitrogen.

The distillate (8g.) had an infrared spectrum identical with that of an authentic sample of phosphorus oxychloride.

On cooling, the residue in the distillation flask solidified to a black, glassy mass which was repeatedly extracted with dry



benzene. Removal of the solvent under vacuum gave a pale-brown solid (8.5g.) which was purified by sublimation at 0.005mm. and 60-70°C. Found, C = 43.36; H = 3.56%, calculated for  $\text{CH}_3\text{C}_6\text{H}_4\text{SO}_2\text{Cl}$ , C = 44.07; H = 3.71%. The infrared spectrum of this material was identical with that of an authentic sample of *p*-toluenesulphonylchloride.

The benzene, insoluble material was insoluble in hexane, acetone, acetonitrile, carbon tetrachloride, chloroform, ethyl alcohol, ethyl acetate and carbon disulphide, but was soluble in dimethyl sulphoxide and dimethylformamide. When treated with benzene it 'softened' to a rubber like material which regained its original hardness on drying. The infrared spectrum of this material contained bands at, 3030m, 1639w, 1590ms, 1492sh, 1447sh, 1379sh, 1250vs, 1170vs, 1093sh, 1011m, ~910ms (very broad), 810m, 702w, 678m, ~660w, ~550s (very broad).

(ix) The reaction between m-nitrobenzenesulphonamide and phosphorus(V) chloride

m-Nitrobenzenesulphonamide (28.3g., 0.140 mole) and A.R. phosphorus(V) chloride (29.2g., 0.140 mole) were well mixed and dry carbon tetrachloride (20ml.) added. The mixture was then heated in an oil bath at 100-110°C. The slow evolution of hydrogen chloride began immediately and the mixture began to liquefy after about 30 minutes. The reaction

was complete after 2 hours when the solution was cooled to 40-50°C and the solvent removed under vacuum. On cooling the product solidified and was recrystallised three times from carbon tetrachloride. Found, C = 21.2; H = 1.5; N = 8.4; Cl = 30.1%;  $O_2N.C_6H_4SO_2N:PCl_3$  requires, C = 21.4; H = 1.2; N = 8.3; Cl = 31.5%. m.pt. 68-69°C. The infrared spectrum of this compound contained bands at, 3115s, 3096sh, 3058w, 2865m, 1931w, 1776w, 1748w, 1613s, 1587m, 1548vs, 1529vs, 1468s, 1431s, 1353vs, 1325vs, 1295sh, 1269sh, 1189sh, 1164vs, 1148s, 1120s, 1081s, 1065s, 1010m, 995m, 934m, 906m, 880vs, 858sh, 818s, 788vs, 745s, 720vs, 637s, 585s, 553s, 510m, ~474m, ~437m.

(x)(a) The reaction between p-chlorobenzenesulphonamide and phosphorus(V) chloride

p-Chlorobenzenesulphonamide (28.1g., 0.147mole) and A.R. phosphorus(V) chloride (30.5g., 0.147 mole) were well mixed and dry carbon tetrachloride (20 ml.) added. The mixture was then heated at 100-110°C for one hour after which time liquefaction was complete. The solution was cooled to 40-50°C and the solvent removed under vacuum. On cooling, the product solidified and was recrystallised twice from carbon tetrachloride. Found, C = 22.6; H = 1.4; N = 4.5; Cl = 43.0%.  $ClC_6H_4SO_2N:PCl_3$  requires, C = 22.0; H = 1.2; N = 4.3; Cl = 43.4% m.pt. 65-66°C.

The infrared spectrum of this compound contained bands at, 3096m, 1923wm, 1923wm, 1589ms, 1582ms, 1563sh, 1473s, 1397s, 1325s, 1290sh, 1280s, 1214vs, 1172sh, 1152vs, 1088vs, 1012s, 954w, 839s, 824s, 784vs, 743s, 705ms, 643sh, 617s, 595sh, 548s, 521s, ~ 483m, ~ 425m.

(x)(b) Pyrolysis of the product, p-chlorophenyltriphlorphosphazosulphone

p-Chlorophenyltrichlorphosphazosulphone (32.7g., 0.1 mole) was placed in a two necked flask fitted with a 30 cm. Vigreux column and an inlet tube for dry nitrogen. A condenser attached to the top of the Vigreux column lead to a receiver cooled to about  $-20^{\circ}\text{C}$  in an acetone/dry ice bath. The system was evacuated and the nitrogen flow rate so adjusted that the internal pressure was maintained at 1-3 mm.Hg. The flask was then heated in an oil-bath at  $210-230^{\circ}\text{C}$  for 6 hours, after which time the system was allowed to cool to room temperature under an atmosphere of nitrogen.

Only a very small amount of ( $\lesssim 1\text{m.}$ ) of distillate had collected in the condenser receiver and this had an infrared spectrum identical with that of an authentic sample of phosphorus oxychloride. The residue from the distillation flask was twice recrystallised from carbon tetrachloride. Found, C = 23.1; H = 1.32; Cl = 43.6%; calculated for  $\text{Cl.C}_6\text{H}_4\text{SO}_2\text{N:PCl}_3$ , C = 22.0; H = 1.2; Cl = 43.4%. The infared spectrum of this material was identical with that of the pure starting material.



(xi) The reaction between p-methoxybenzenesulphonamide and phosphorus(V) chloride

p-Methoxybenzenesulphonamide (23.8g., 0.127 mole) and A.R. phosphorus(V) chloride (26.5g., 0.127 mole) were well mixed and dry carbon tetrachloride (20 ml.) added. The mixture was then heated in an oil-bath at 100-110°C for one hour, after which time liquefaction was complete. After cooling to 40-50°C the solvent was removed under vacuum and the solid product was twice recrystallised from carbon tetrachloride. Found, C = 25.4; H = 2.3; N = 4.2; Cl = 32.4%;  $\text{CH}_3\text{OC}_6\text{H}_4\text{SO}_2\text{N:PCl}_3$  requires, C = 26.1; H = 2.2; N = 4.3; Cl = 33.0%. m.pt. 82-83°C. The infrared spectrum of this compound contained bands at, 3015m, 3067w, 3030wm, 2994s, 2950s, 2915m, 2849m, 1964m, 1931m, 1916m, 1887m, 1783w, 1689w, 1661m, 1631w, 1600s, 1582s, 1563sh, 1504vs, 1464s, 1451sh, 1445s, 1412m, 1379w, 1315vs, 1299vs, 1266vs, 1212s, 1176s, 1152s, 1088s, 1018vs, 944w, 841s, 822m, 816sh, 807s, 754s, 722sh, 633s, 620s, 584sh, 570s, 543ms, 513m, 451m, 445sh, ~410m.

(xii) The reaction between p-toluenesulphonamide and triphenylphosphine dichloride<sup>397</sup>

p-Toluenesulphonamide (12.3g., 0.072mole) and triphenylphosphine-dichloride (23.9g., 0.072 mole) were well mixed and heated in an oil-bath at 140-150°C for 2½ hours. On cooling, the viscous liquid set to a glassy solid which was recrystallised four times

from toluene. During the first crystallisation the hot solution was filtered to remove a small amount of unchanged starting material. Found, C = 69.22; H = 5.61%; calculated for  $\text{CH}_3\text{C}_6\text{H}_4\text{SO}_2\text{N}:\text{P}(\text{C}_6\text{H}_5)_3$ , C = 69.52; H = 5.15%. m.pt. 187-188°C (reported 186-187°C). The infrared spectrum of this compound contained bands at 3367m, 3268m, 3067w, 3030w, 2924w, 1923w, 1605m, 1590m, 1534w, 1492m, 1486ms, 1443s, 1399w, 1368w, 1335w, 1309m, 1290w, 1266vs, 1253sh, 1178m, 1163sh, 1151vs, 1139s, 1112s, 1105sh, 1085m, 1029w, 1017w, 999m, 909w, 853w, 837w, 820ms, 813ms, 787m, 763ms, 749ms, 725s, 707sh, 694s, 681m, 654m, 579m, 560s, 529sh, 522vs, 487w.

(d) Reactions between  $\alpha$ -sulphanuric chloride and donor molecules

(i,a) The reaction between  $\alpha$ -sulphanuric chloride and pyridine

Pyridine (0.48g., 0.006 mole) was added, at room temperature, to a solution of  $\alpha$ -sulphanuric chloride (0.59g., 0.002 mole) in toluene (10ml.) An immediate turbidity was formed and a pale-yellow oil was slowly deposited from the solution. After 24 hours at room temperature the oil had darkened to a golden-red colour and was very viscous. The solvent was removed by careful decantation and the oil washed with toluene (3 x 10 ml.), then chloroform (2 x 10ml.) and dried under vacuum. Found, C = 31.8; H = 3.0; N = 15.3; S = 20.1; Cl = 20.1%;  $3(\text{C}_5\text{H}_5\text{N})$ .  $(\text{NSOCl})_3$  requires, C = 34.0; H = 2.9; N = 15.9; S = 18.2; Cl = 20.2%.

The product was insoluble in hexane, toluene, chloroform, carbon disulphide, ethyl alcohol and acetone. Hydrolysis with sodium hydroxide solution followed by ether extraction gave a liquid which was identified as pyridine from its infrared spectrum and elemental analysis. The infrared spectrum of the adduct contained bands at, 3058s, 3012s, 2941m, ~2597s (very broad), 2083ms, 1643m, 1613s, 1538s, 1488s, 1408w, 1385m, 1300vs, 1253sh, 1198sh, 1166s, 1122s, 1110sh, 1059vs, 1011s, 930sh, 813ms, 800ms, 750s, 702sh, 681vs, 659s, 636w, 609ms, 569s, 529ms, 524ms, 489w.

The adduct was dissolved in dimethylsulphoxide and an excess of toluene added to give a new oil, the infrared spectrum of which contained bands at, 3067sh, 2994s, 2915m, ~2600ms (very broad), 2089ms, 1634m, 1613ms, 1536m, 1486s, 1433s, 1418sh, 1350sh, 1330sh, 1300s, 1250sh, 1221s, 1161s, 1134s, 1045vs, 1015sh, 953s, ~855s (broad), 752s, 733sh, 684s, 667w, 610m, 580s, 559s, 530w, 488ms.

(i,b) Pyrolysis of the adduct  $3(C_5H_5N)$ . (NSOC1)<sub>3</sub>

The adduct was heated at 70-80°C under a pressure of ~2mm. Hg. and the pyrolysis product collected on a cold finger cooled to -78°C with an acetone-dry ice mixture. The product, a white solid, was resublimed a further two times. Found, C = 41.3; H = 3.86; Cl = 23.81. The infrared spectrum contained bands at, 3125sh, 2597s(very broad), 2092s, 2028sh, 1653sh, 1631s, 1610vs,

1529s, 1501w, 1547s, 1412s, 1338s, 1333ms, 1304m, 1269w, 1248ms, 1192ms, 1165m, 1148m, 1135m, 1110w, 1081m, 1053s, 1040sh, 1021sh, 1002s, 915ms, 875w, 832m, 820m, 810vs, 705w, 676vs, 669sh, 664sh, 607s, 529m, 516sh, 485m, 444sh, 430wm (broad).

Hydrolysis followed by ether extraction gave pyridine which was identified by its infrared spectrum and elementary analysis.

(iii, a) The reaction between  $\alpha$ -sulphanuric chloride and iso-quinoline

$\alpha$ -Sulphanuric chloride (0.59g., 0.002 mole) was dissolved in toluene (10 ml.) and a solution of iso-quinoline (0.77g., 0.006mole) in toluene (10 ml.) added at room temperature. The separation of a pale-yellow oil began immediately. The reaction was complete in one hour, after which time the oil had darkened to a red-brown colour. The solvent was removed by careful decantation, the oil washed with toluene (3 x 10ml.) and dried under vacuum. Found, C = 47.5; H = 3.6; Cl = 16.1%;  $3(C_9H_7N).(NSOCl)_3$  requires, C = 47.7; H = 3.1; Cl = 15.6%. The solubilities of this compound were similar to those of the corresponding pyridine compound. The infrared spectrum contained bands at, 3086sh, 3012s, 2976sh, 2604s(very broad), 2299sh, 1066ms, 1642s, 1611s, 1590w, 1543m, 1493m, 1477m, 1408sh, 1387s, 1370ms, 1357ms, 1342sh, 1297vs, 1274sh, 1253sh, 1238sh, 1215w, 1165s, 1136sh, 1120s, 1059s, 1033sh, 1011sh, 994sh, 977ms, 970sh, 945w, 922w, 866m, 824s, 799s, 772m, 747m, 700sh, 683s, 657s, 601w, 623w, 610s, 539sh, 525m, 508s, 474s.

Hydrolysis with sodium hydroxide solution followed by ether extraction gave iso-quinoline which was identified by its infrared spectrum and elemental analysis.

The adduct was dissolved in dimethylsulphoxide and an excess of toluene added. The red-brown solution was decanted from the precipitated oil and evaporated under vacuum to give a red-brown solid. This solid was twice recrystallised from a dimethylsulphoxide-toluene mixture. Found, C = 38.8; H = 3.7; N = 9.8; Cl = 16.8%;  $2(C_9H_7N).(CH_3)_2SO.(NSOCl)_3$  requires, C = 38.2; H = 3.2; N = 11.1; Cl = 16.9%. The infrared spectrum contained bands at, 3226w, 3030sh, 2976s, 2898m, 2618s, 2398w, 2105wm, 2058wm, 1653s, 1639vs, 1607s, 1541m, 1490m, 1433ms, 1418m, 1408m, 1391m, 1374m, 1355w, 1311s, 1282m, 1259m, 1131w, 1086w, 1047sh, 1033s, 1010ms, 945ms, 910vs, 855ms, 833ms, 800ms, 754w, 723s, 680wm, ~560wm (broad), 508m, 484w, 473w.

(ii, b) Pyrolysis of the adduct,  $3(C_9H_7N).(NSOCl)_3$

The adduct was heated at 70-80°C under a pressure of 1-2 mm.Hg. and the pyrolysis product collected on a cold finger cooled to -78°C with an acetone-dry ice mixture. The product, a white solid, was resublimed and then recrystallised from a dimethylsulphoxide-toluene mixture. Found, C = 55.85; H = 3.64; Cl = 16.70%. The infrared spectrum contained bands, at 3076sh,

3030sh, 2353s (very broad), 2060 ms, 1639s, 1610s, 1587sh, 1538w, 1488sh, 1408w, 1361s, 1333sh, 1287m, 1272wm, 1250w, 1220w, 1170sh, 1149ms, 1053wm, 1033w, 1012w, 966m, 947w, 922w, 868m, 837s, 800ms, 769w, 754s, 727s, 623ms, 538w, 512s, 506sh, 473s.

Hydrolysis with sodium hydroxide solution followed by ether extraction gave iso-quinoline which was identified by its infrared spectrum and elementary analysis.

(iii) The reaction between  $\alpha$ -sulphanuric chloride and trimethylamine

$\alpha$ -Sulphanuric chloride (0.59g., 0.002 mole) was dissolved in toluene and the solution cooled in liquid nitrogen. An excess ( $\sim 270$  N.c.c.,  $\sim 0.012$  mole) of trimethylamine was condensed into the flask, which was then kept at  $-25^{\circ}\text{C}$  for  $\frac{1}{2}$  hours.

The solid product was separated by filtration, washed with toluene (3 x 10 ml.) and dried under vacuum. Found, C = 23.6; H = 5.9; Cl = 21.1%;  $3[(\text{CH}_3)_3\text{N}] \cdot (\text{NSOCl})_3$  requires, C = 23.2; H = 5.8; Cl = 22.7%. The infrared spectrum contained bands at, 2725sh, 2667sh, 2631s, 2481m, 1634w, 1481s, 1456vs, 1425w, 1330s, 1312s, 1263w, 1245m, 1185m, 1136s, 1076s, 1052m, 991ms, 966sh, 953m, 813w, 773m, 738sh, 722wm, 690m, 639w, 614wm, 594s, 559m, 515m.

(iv) The reaction between  $\alpha$ -sulphanuric chloride and triphenylphosphine

To a solution of  $\alpha$ -sulphanuric chloride (0.59g., 0.002 mole) in toluene (5 ml.) was added, at room temperature, a solution of

triphenylphosphine (1.57g., 0.006 mole) in toluene (5 ml.)  
 A golden red oil slowly separated from the solution. The  
 reaction seemed complete after 22 hours. The solvent was  
 removed by decantation and the extremely viscous oil was washed  
 with toluene (3 x 10 ml.) and dried under vacuum. Found, C =  
 61.5; H = 4.7; Cl = 9.2%:  $[(C_6H_5)_3P]_3 \cdot (NSOCl)_3$  requires,  
 C = 60.1; H = 4.2; Cl = 9.9%. Insoluble in hexane, toluene,  
 chloroform and carbon tetrachloride. The compound dissolved  
 in nitromethane, and toluene added to give triphenylphosphine  
 dichloride, which was identified by its infrared spectrum and  
 elemental analysis.

(e) Reactions between other sulphur(VI) compounds and donor molecules

(i) The reaction between pyridine and sulphuryl chloride

(a) Preparation of the 2:1 adduct,  $2(C_5H_5N)SO_2Cl_2$

Sulphuryl chloride (4.05g., 0.03 mole) was dissolved in dry  
 heptane (20 ml.) and cooled to 0°C in an ice bath. An excess  
 of pyridine (10 ml.) was added over 5 minutes with vigorous  
 stirring. A pale-yellow oil began to separate immediately.  
 The mixture was allowed to warm to room temperature and was  
 maintained at this temperature, with constant stirring, for  
 3 hours. During this time the oil darkened to a red-brown  
 colour and its viscosity greatly increased. The solvent was  
 removed by decantation and the oil washed with dry heptane  
 (3 x 20ml.) then with dry chloroform (2 x 20 ml.) and dried  
 under vacuum.

When dry the oil was very viscous and 'frothed' badly under vacuum. Found, C = 42.40; H = 3.70; Cl = 25.79%;  $2(C_5H_5N)$ .  $SO_2Cl_2$  requires, C = 41.27; H = 3.44; Cl = 24.15%. The infrared spectrum contained bands at 3125sh, 3058s, 3021sh, 2932m, 2849w,  $\sim$  2500s, (very broad), 2096ms, 1618s, 1595vs, 1520s, 1475vs, 1464sh, 1403s, 1374m, 1328sh, 1271s, 1244s, 1182s, 1156m, 1115ms, 1105sh, 1049ms, 1019w, 993vs, 928w, 901w, 887w, 870w, 838m, 819m, 789ms, 751vs, 723w, 679vs, 659sh, 636sh, 606s, 588ms, 552sh, 524ms. On standing for about 24 hours the oil began to solidify and after about 7 days had set to a solid mass.

(b) Pyrolysis of the adduct

The oily adduct was heated at 90-100°C under a pressure of 0.01mm.Hg and the decomposition product was collected on a cold finger cooled with liquid nitrogen. The white solid collected on the cold finger was purified in the following manner. The solid was dissolved in nitromethane and toluene added in portions to the solution. During the initial stages of the addition the compound separated as an oil but as the solution became more dilute, crystals began to separate. At this stage the solution was separated from the oil and further diluted with toluene. The crystals so obtained were similarly recrystallised a further two times and were dried under vacuum.



Hydrolysis with sodium hydroxide solution followed by ether extraction gave a liquid which was identified as pyridine by its infrared spectrum and elemental analysis. Analysis of the recrystallised product gave, C = 46.24; H = 4.98; N = 10.71; Cl = 28.05%. The infrared spectrum, which was identical with that of the crude product, contained bands at, 3134w, 3095w, 3049s, 2410s (very broad) 2096ms, 1631ms, 1621w, 1605s, 1529s, 1504sh, 1488s, 1387wm, 1342w, 1316m, 1242ms, 1202wm, 1161m, 1104m, 1055ms, 1026w, 1001s, 942m, 837w, 814ms, 749vs, 722sh, 680vs, 668sh, 609s.

(c) Attempted preparation of the 1:1 adduct,  $C_5H_5N \cdot SO_2Cl_2$

Sulphuryl chloride (4.05g., 0.03 mole) was dissolved in dry heptane (20 ml.) and cooled to 0°C in an ice bath. Pyridine (2.37g., 0.03 mole) was added with vigorous stirring. A pale-yellow oil began to separate immediately and was worked up as in (a) above. Found, C = 40.10; H = 3.35; Cl = 26.00%;  $2(C_5H_5N) \cdot SO_2Cl_2$  requires, C = 41.27; H = 3.44; Cl = 24.15%.

(ii) The reaction between triethylamine and sulphuryl chloride

Sulphuryl chloride (2.70g., 0.02 mole) was dissolved in dry toluene (10 ml.) and cooled to 0°C in an ice bath. A solution of triethylamine (2.02g., 0.02 mole) in dry toluene (10 ml.) was added over 10 minutes with vigorous stirring. A rapid, exothermic, reaction occurred with the formation of a white

precipitate. The precipitate was separated by filtration, washed with dry toluene (3 x 10 ml.), dried under vacuum and recrystallised twice from a nitromethane-toluene (1:2<sup>v/v</sup>) mixture. Found, C = 52.19; H = 11.14; N = 9.43; Cl = 24.60%; calculated for  $(C_2H_5)_3N.HCl$ , C = 52.34; H = 11.73; N = 10.17; Cl = 25.75%. Evaporation to dryness of the original filtrate gave traces of a red-brown oil.

(iii) The reaction between triphenylphosphine and sulphuryl chloride

(a) Preparation of the 1:1 adduct,  $(C_6H_5)_3P.SO_2Cl_2$

Triphenylphosphine (7.86g., 0.03 mole) was dissolved in dry heptane (20 ml.) and a solution of sulphuryl chloride (4.05g., 0.03 mole) in dry heptane (10 ml.) was added over 10 minutes, with constant stirring, at room temperature. A mildly exothermic reaction occurred and a pale-yellow, mobile oil separated slowly from the solution. The solution was allowed to stand overnight at room temperature. The solvent was removed by careful decantation and the oil washed with dry heptane (2 x 10 ml.) dissolved in dry chloroform (20 ml.) and reprecipitated by the addition of heptane (20 ml.) On standing for 5 minutes the oil solidified. The solid was separated by filtration, washed with dry heptane (2 x 10 ml.) and dried under vacuum. Found, C = 53.46; H = 3.23; Cl = 16.84%;  $(C_6H_5)_3P.SO_2Cl_2$  requires, C = 54.43; H = 3.81; Cl = 17.84%. m.pt. 60-80°C.

To the solid product was added chloroform (20 ml.), a large proportion of the solid was insoluble, even in the boiling solvent. The insoluble portion was separated by filtration and dried under vacuum. Found, C = 53.61; H = 3.26; Cl = 18.91%;  $(C_6H_5)_3P \cdot SO_2Cl_2$  requires, C = 54.43; H = 3.81; Cl = 17.84% m.pt.,  $180^\circ$  (dec). The product was insoluble in hot toluene, hexane and carbon tetrachloride. The infrared spectrum contained bands at, 3082w, 3058w, 2481m, 1919w, 1835w, 1695w, 1580s, 1570sh, 1479s, 1438vs, 1342wm, 1314ms, 1263s, 1188wm, 1161wm, 1145w, 1107vs, 1099s, 1072w, 1031w, 996s, 853w, 760vs, 747vs, 727vs, 697sh, 669sh, 656s, 616s, 565s, 535m, 513ms.

The filtrate containing the chloroform soluble portion was evaporated to small bulk (~5 ml.) and hexane (20 ml.) was added. A colourless oil separated. The solvent was removed by careful decantation and the oil dried under vacuum. Found, C = 53.32; H = 3.24; Cl = 18.70%;  $(C_6H_5)_3P \cdot SO_2Cl_2$  requires, C = 54.43; H = 3.81; Cl = 17.84%. On standing several days the oil slowly solidified, m.pt.  $65-70^\circ$  C. The infrared spectrum contained bands at, 3158w, 3086m, 3062m, 3021m, 2915w, 2869w, 2519vw, 2309vw, 2203vw, 1908vw, 1818vw, 1681vw, 1605m, 1582s, 1493s, 1481s, 1435vs, 1332sh, 1312sh, 1279vs, 1185wm, 1163wm, 1120sh, 1106vs, 1096sh, 1077w, 1040vs, 1026w, 993m, 935w, 749s, 729vs, 696s, 685s, 617s, 578s, 536vs, 513s.

(b) Pyrolysis of the chloroform insoluble product

The solid was heated at 170-180°C under a pressure of 0.01mm.Hg and the decomposition products were collected on a cold finger cooled to -78°C with an acetone-dry ice mixture. A white solid collected on the cold finger and traces of a liquid collected on the upper part of the flask. The solid material after removal from the cold finger was subjected to prolonged pumping under high vacuum. Its infrared spectrum was identical with that of the starting material.

(c) Attempted preparation of the 2:1 adduct,  $[(C_6H_5)_3P]_2 \cdot SO_2Cl_2$ 

Triphenylphosphine (7.86g., 0.03 mole) was dissolved in dry heptane (20 ml.) and a solution of sulphuryl chloride (2.03g., 0.015 mole) in dry heptane (5 ml.) was added over 5 minutes at room temperature. The pale-yellow oil which separated from the solution was worked up as in (d) above. Found, C = 53.91; H = 3.12; Cl = 17.63%;  $(C_6H_5)_3P \cdot SO_2Cl_2$  requires, C = 54.43; H = 3.81; Cl = 17.84%.

(iv) The reaction between triphenylstibine and sulphuryl chloride

Triphenylstibine (3.35g., 0.01 mole) was dissolved in dry toluene (10 ml.) and cooled to 0°C in an ice-salt bath. A solution of sulphuryl chloride (1.35g., 0.01 mole) in dry toluene (10 ml.) added over 10 minutes with constant stirring. The solution was allowed to warm to room temperature and dry

hexane (20 ml.) added. Colourless crystals were deposited immediately and were separated by filtration, washed with dry hexane (2 x 10 ml.) and dried under vacuum. Found, C = 50.52; H = 3.94; Cl = 16.02%; calculated for  $(C_6H_5)_3SbCl_2$ , C = 50.98; H = 3.57; Cl = 16.73%.

(v) The reaction between triphenylarsine and sulphuryl chloride

Triphenylarsine (3.06g., 0.01 mole) was dissolved in dry toluene (10 ml.) and cooled to 0°C in an ice-salt bath. A solution of sulphuryl chloride (1.35g., 0.01 mole) in dry toluene (10 ml.) was added over 10 minutes with constant stirring. Colourless crystals separated during the addition. These were separated by filtration, washed with dry, ice-cold toluene (2x5 ml.) and dried under vacuum. Found, C = 57.89; H = 4.20; Cl = 17.95%; calculated for  $(C_6H_5)_3AsCl_2$ , C = 57.32; H = 4.02; Cl = 18.80%.

(vi) The reaction between pentafluorobenzene sulphonamide and pyridine

Pentafluorobenzene sulphonamide (2.47g., 0.01 mole) mixed with an excess of pyridine (5 ml.) and warmed to 50-55°C, at which temperature the sulphonamide was soluble. A deeply orange coloured solution was obtained. The solution was maintained at 50-55°C with constant stirring, for 4 hours, cooled to room temperature, dry toluene (40 ml.) added, the precipitate separated by filtration

washed with dry heptane (2 x 10 ml.) and dried under vacuum. The solid material had an infrared spectrum identical with that of pentafluorobenzene sulphonamide, and a mixed melting point confirmed it as unchanged starting material.

(vii) The reaction between diphenyl sulphone and pyridine

Diphenyl sulphone (2.18g., 0.01 mole) was dissolved in dry toluene and an excess of pyridine (5 ml.) added over 5 minutes at room temperature with constant stirring. The temperature of the solution rose to 40-50°C during the addition; when the solution had returned to room temperature dry heptane (50 ml.) was added, and the white crystals obtained were separated by filtration and dried under vacuum. A mixed melting point showed these to be unchanged diphenyl sulphone.

(viii) The reaction between sulphamide and pyridine

Sulphamide (0.96g., 0.01 mole) dissolved in an excess of pyridine (8 ml.) and maintained at room temperature for 17 hours. The solution was then warmed to 50-60°C for 30 minutes after which time an excess of dry toluene (50 ml.) was added. The resultant precipitate was separated by filtration, washed with toluene (10 ml.) and then with hexane (10 ml.) and dried under vacuum. A mixed melting point showed the solid to be unchanged sulphamide.

(ix) The Reaction between benzene sulphonamide and pyridine

Benzene sulphonamide (3.14g., 0.02 mole) was mixed with pyridine (3.16g., 0.04 mole) and warmed to 75-85° at which temperature the sulphonamide was completely soluble. The solution was maintained at this temperature for 24 hours, cooled to room temperature and dry toluene (20 ml.) added. After filtration the solid material was washed twice with dry toluene (10 ml.) and dried under vacuum. A mixed melting point showed the solid to be unchanged benzene sulphonamide.

(x) The reaction between benzenesulphonyl chloride and pyridine

(a) Using only a small excess of pyridine

Benzenesulphonyl chloride (3.53g., 0.02 mole) was dissolved in dry heptane (10 ml.) and a solution of pyridine (1.96g., 0.025 mole) in dry heptane (10 ml.) added over 5 minutes, with constant stirring at room temperature. After some 30 minutes a very faint turbidity developed. The reaction was maintained at room temperature for a further 4 hours, with only little increase in the volume of precipitate. The solution was then warmed to 50-60° for 30 minutes and, after cooling to room temperature, filtered. Only mg. quantities of solid material was obtained and this had m.pt., 128-130°C.

(b) Using a large excess of pyridine

Benzene sulphonyl chloride (3.53g., 0.02 mole) was dissolved in dry toluene (10 ml.) and pyridine (12 ml.) added over 10 minutes, with constant stirring, at room temperature. The solution was maintained at room temperature for 72 hours, after which time it was evaporated to small volume (~2 ml.) under vacuum. Dry hexane (30 ml.) was then added and the very small amount of solid material separated by filtration, washed three times with dry hexane (10 ml.) and dried under vacuum. m.p. 128-130°. Found, Cl = ~1.0%; calculated for  $C_5H_5N.C_6H_5SO_2$  Cl, Cl = 13.9%.

(xi) The reaction between benzenesulphonyl chloride and triphenylphosphine

Benzenesulphonyl chloride (1.77g., 0.01 mole) was dissolved in 5 ml. of a mixture of toluene and heptane (1:1<sup>v</sup>/v). To this solution was added over 10 minutes a solution of triphenylphosphine (2.62g., 0.01 mole) in 40 ml. of the same solvent mixture. An immediate turbidity developed and a colourless oil began to separate; after a further 10 minutes this oil crystallised to a white solid. The reaction mixture was maintained at room temperature, with constant stirring, for 3 hours, after <sup>which time</sup> the solid product was separated by filtration, dissolved in dry acetonitrile, reprecipitated by addition of dry hexane, filtered and dried under vacuum. m.pt. 152-154°C, Found, C = 77.3; H = 5.7; Cl = 0.0%, calculated for  $(C_6H_5)_3PO$ , C = 77.7; H = 5.4%; m.pt. 156°C.



(f) Thionyl chloride and phosphorus oxychloride with donor molecules

(i) The reaction between thionyl chloride and pyridine

Thionyl chloride (3.57g., 0.03 mole) was dissolved in dry carbon tetrachloride (30 ml.) and cooled to 0°C in an ice bath. An excess of pyridine (10 ml.) was added over 5 minutes with constant stirring. The system was allowed to warm to room temperature and was kept at this temperature for 2 hours. The temperature was then increased to 50°C for 2 hours after which time only traces of a white precipitate had formed. Dry heptane (50 ml.) was then added to give a slight increase in the amount of precipitate. The solid was then separated by filtration and dried under vacuum. Found, Cl = 31.0%; calculated for  $C_5H_5N.HCl$ , Cl = 30.8%. The infrared spectrum of this material was identical with that of an authentic sample of pyridine hydrochloride.

(ii) The reaction between phosphorus oxychloride and pyridine<sup>399</sup>

(a) Under anhydrous conditions

Pyridine (5.54g., 0.07 mole) was dissolved in dry carbon tetrachloride (25 ml.) and phosphorus oxychloride (4.60g., 0.03 mole) was added at room temperature, with constant stirring. A very small amount of a white precipitate formed over about 1 hour. The temperature was then increased to 50-55°C for 16 hours, no further increase in the amount of precipitate being

observed. Evaporation to dryness under vacuum gave traces of a white solid the infrared spectrum of which was identical with that of an authentic specimen of pyridine hydrochloride. This reaction was repeated in other solvents, hexane and toluene, without solvent and using a large excess of pyridine. In all cases only trace quantities of pyridine hydrochloride could be obtained.

(b) Using unpurified reagents

An excess of pyridine (10.0 mole) was added to phosphorus oxychloride (4.60g., 0.03 mole) and the solution allowed to stand at room temperature for one hour. To the solution hexane (50 ml.) was added and the precipitated white solid was separated by filtration, washed with hexane (3 x 10 ml.) and dried under vacuum. Found, C = 49.22; H = 3.21; Cl = 33.39%,  $(C_5H_5N)_2 \cdot POCl_3$  requires, C = 38.51; H = 3.20; Cl = 34.23%. m.pt. 50-70°C.

(g) The donor properties of  $\alpha$ -sulphanuric chloride

(i) The reaction between  $\alpha$ -sulphanuric chloride and hexamethyl benzene

(a) With reactants in 1:1 mole ratio.

$\alpha$ -Sulphanuric chloride (0.585g., 0.002 mole) was dissolved in dry toluene (5 ml.) and a solution of hexamethylbenzene (0.324g., 0.002 mole) in dry toluene (5 ml.) was added rapidly, with constant stirring, at room temperature. The solution gradually acquired a faint pink colour. After standing for 24 hours a very small amount of a flocculent precipitate had separated from a dark red solution.

The solid material was separated by filtration and dried under vacuum. Found, Cl = 16.1%:  $(\text{NSOCl})_3 \cdot 2[\text{C}_6(\text{CH}_3)_6]$ , requires Cl = 17.3%. The filtrate when evaporated to dryness gave a red-brown solid. Found, Cl = 20.7%:  $(\text{NSOCl})_3 \cdot \text{C}_6(\text{CH}_3)_6$ , requires Cl = 23.4%.

(b) With reactants in 1:2 mole ratio

$\alpha$ -Sulphanuric chloride (0.585g., 0.002 mole) was dissolved in dry toluene (5 ml.) and a solution of hexamethylbenzene (0.648g., 0.004 mole) in dry toluene (10 ml.) was added rapidly at room temperature. As in (a) after 24 hours only a small amount of a pale-yellow solid had precipitated from solution.

(c) With the hexamethylbenzene in excess

$\alpha$ -Sulphanuric chloride (0.585g., 0.002 mole) was dissolved in toluene (5 ml.) and a solution of hexamethylbenzene (1.62g., 0.01 mole) in toluene (15ml.) was added at room temperature. After 24 hours at this temperature no pink colour had developed and no precipitate had formed. Hexane (30 ml.) was added and a cream coloured precipitate obtained which was separated by filtration and dried under vacuum. Found, C = 20.5; H = 4.2; Cl = 15.8%:  $(\text{NSOCl})_3 \cdot 2[\text{C}_6(\text{CH}_3)_6]$  requires, C = 23.4; H = 2.9; Cl = 17.3%. Attempted purification by sublimation or recrystallisation from hot solvents caused decomposition to a red-brown solid.

(ii) The reaction between  $\alpha$ -sulphanuric chloride and beryllium chloride

Beryllium chloride (0.40g., 0.005 mole) was slurried with dry toluene (20 ml.) and a solution of  $\alpha$ -sulphanuric chloride (1.46g., 0.005 mole) in dry toluene (20 ml.) was added over 10 minutes, with constant stirring, at 40°C. Undissolved beryllium chloride was still present under these conditions. The system was maintained at 40-50°C for 70 hours after which time the residual solid was separated by filtration. The filtrate was evaporated dryness and the solid obtained recrystallised from heptane. m.pt. 142-144°C ( $\alpha$ -(NSOC1)<sub>3</sub>, 144°C). The infrared spectrum of this material was identical with that of an authentic sample of  $\alpha$ -sulphanuric chloride.

(iii) The reaction between  $\alpha$ -sulphanuric chloride and mercury(II) chloride.

Mercury(II) chloride (0.54g., 0.002 mole) was dissolved in dry ether (10 ml.) and a solution of  $\alpha$ -sulphanuric chloride (0.59g., 0.002 mole) was added rapidly at room temperature. The solution was maintained at this temperature, with constant stirring, for 24 hours. The solvent was removed under vacuum and the solid residue extracted with toluene (10 ml.) After filtration the solvent was removed under vacuum and the solid obtained was shown by its m.pt. and infrared spectrum to be unchanged  $\alpha$ -sulphanuric chloride.

(iv) The reaction between  $\alpha$ -sulphanuric chloride and titanium(IV) chloride.

$\alpha$ -Sulphanuric chloride (0.29g., 0.001 mole) was dissolved in dry toluene and an excess of titanium(IV) chloride (0.006 mole) was added at room temperature. An orange-red colour developed immediately. The solution was maintained at room temperature, with constant stirring, for 16 hours after which time a small amount of a black oil had separated from the solution. Addition of hexane caused the separation of more black oil. The solvent was removed by decantation and the oil dried under vacuum to give a viscous, black, tarry material which was not investigated further.

(v) The reaction between  $\alpha$ -sulphanuric chloride and niobium(V) chloride.

Niobium(V) chloride (0.39g., 0.0015 mole) was slurried with dry carbon tetrachloride (10 ml.) and a solution of  $\alpha$ -sulphanuric chloride (0.429g., 0.0015 mole) was added over 10 minutes, with constant stirring, at room temperature. A deep red colour developed immediately. After about 10 minutes an orange-red solid began to precipitate from the solution and after a further 10 minutes decomposition to give a brown-black solid occurred. The reaction was not investigated further.

(h) Metathesis reactions of  $\alpha$ -sulphanuric chloride

(i) The reaction between  $\alpha$ -sulphanuric chloride and butyl lithium

$\alpha$ -Sulphanuric chloride (1.46g., 0.005 mole) was dissolved in benzene (20 ml.) and cooled to 0°C in an ice bath. A solution of n-butyl lithium (6.1 ml., 2.45M, 0.015 mole) was then added with constant stirring. A white precipitate formed immediately. The solution was warmed to room temperature and maintained at this temperature for 3 hours. The precipitate was separated by filtration and the filtrate evaporated to dryness under vacuum to give only a small amount of a low melting ( $\sim 40^\circ\text{C}$ ) solid. The original precipitate was then further extracted with benzene, then ether, to give further small amounts of the low melting solid. The infrared spectrum of this material contained bands at, 2950s, 2920sh, 1543w, 1560w,  $\sim 1250\text{s}$  (broad), 1111sh,  $\sim 990\text{vs}$  (broad),  $\sim 275\text{ cm}^{-1}$ ), 813w, 725w,  $\sim 650\text{m}$  (broad).

(ii) The reaction between  $\alpha$ -sulphanuric chloride and methyl lithium

$\alpha$ -Sulphanuric chloride (0.59g., 0.002 mole) was dissolved in ether and cooled to  $-10^\circ\text{C}$  in an ice bath. A solution of methyl lithium (12.5 ml. 0.48M, 0.006 mole) was then added with constant stirring. An orange colour developed immediately. The solution was warmed to room temperature when a white precipitate was

deposited from a colourless solution. After standing for 3 hours the solid was separated by filtration and dried under vacuum. The infrared spectrum contained bands at, 1613w, 1410w, 1205s (broad) 1058sh, 1020s (very broad), 950sh, 900sh, 813w, 722m. The filtrate when evaporated to dryness gave a small amount of a white solid which was transparent in the infrared.

(iii) The reaction between  $\alpha$ -sulphanuric chloride and potassium thiocyanate.

A solution of  $\alpha$ -sulphanuric chloride (1.46g., 0.005 mole) in acetonitrile (10 ml.) was added, with constant stirring, to a slurry of potassium thiocyanate (1.46g., 0.015 mole) in acetonitrile (10 ml.) An intense orange-brown colour developed immediately and an orange precipitate was deposited. After 2 hours at room temperature the solid was separated by filtration and dried under vacuum. This solid was insoluble in benzene, acetone, ethyl alcohol, water, carbon disulphide and dimethylsulphoxide; slightly soluble in acetonitrile and dimethylformamide. The infrared spectrum contained bands at, 1543w, 1481sh, 1449m, 1299s, 1227sh, 1163s, 1129sh, 1064m, 1019m, 922w, 855w, 787w, 683m, 637sh, 615s, 533w.

(iv) The reaction between  $\alpha$ -sulphanuric chloride and phenylmagnesium bromide

(a) Using mole ratio 1:3

$\alpha$ -Sulphanuric chloride (0.70g., 0.0024 mole) was dissolved

in ether (10 ml.) and the solution cooled to 0°C in an ice-bath. An ethereal solution of phenylmagnesium bromide (8.0 ml., 0.90M, 0.0072 mole) was added over 10 minutes with constant stirring. A deep red-brown colour developed but no precipitate formed. The solution was kept at 0°C for 1 hour, and then at room temperature for a further 2 hours. Removal of the solvent under vacuum gave a red-brown solid, insoluble in ether, hexane, toluene and chloroform. Extraction with acetonitrile gave a red-brown solution which was separated from the residual white solid by filtration. Removal of the solvent under vacuum gave a pale red-brown solid, the infrared spectrum of which contained bands at, 3175ms, 3077sh, 2315s, 2288vs, 1679w, 1623m, 1560w, 1479sh, 1408m, 1449s, 1375s, 1368m, 1277sh, 1264m, 1163w, 1109sh, 1077w, 1035s, 995w, 930ms, 803w, 749m, 729w, 702m, 687m. Found, C = 26.93; H = 3.17; N = 8.85; S = 7.17%.  $[\text{NS(O)C}_6\text{H}_5]_3$  requires, C = 51.76; H = 3.62; N = 10.07; S = 23.02%.

(b) Using mole ratio 1:1

$\alpha$ -Sulphanuric chloride (0.70g., 0.0024 mole) was dissolved in ether and the solution cooled to -20°C in an acetone-dry ice bath. An ethereal solution of phenylmagnesium bromide (26.6 ml., 0.09M, 0.0024 mole) was added dropwise, with stirring, over 45 minutes. The solution was maintained at 0°C for a further 45 minutes and then warmed to room temperature for 22 hours. After this time a white solid and a red-brown oil had separated from



the solution. Removal of the solvent under vacuum gave a red-brown solid from which only traces of a red-brown oil could be extracted with heptane and toluene. Extraction with nitromethane gave, after removal of the solvent, a red-brown oil which was vacuum distilled onto a micro-cup cold finger. Found, C = 48.06; H = 3.25%; calculated for  $C_6H_5NSO$ , C = 51.77; H = 3.63%. The infrared spectrum contained bands at, 3077s, 3040m, 2967w, 2933w, 1605w, 1587w, 1560m, 1490m, 1464s, 1449sh, 1389m, 1319sh, 1276ms, 1235m, 1193m, 1172ms, 1163ms, 1077w, 1047vw, 1028w, 1012w, 907w.

(v) The reaction between  $\alpha$ -sulphanuric chloride and N,N diethylamino-trimethylsilane

$\alpha$ -Sulphanuric chloride (0.80g., 0.0027 mole) was dissolved in toluene (10 ml.) and cooled to  $-78^\circ\text{C}$  in an acetone-dry ice bath. A solution of N,N diethylaminotrimethylsilane (1.17g., 0.0081 mole) in toluene (11.7 ml.) was then added, with constant stirring. The solution was maintained at  $-78^\circ\text{C}$  for 30 minutes and then at room temperature for 21 hours. The golden-red solution was evaporated under vacuum to give a golden-red oil. Found, C = 33.5; H = 6.96%;  $(NSO(C_2H_5)_2)_3$  requires, C = 35.80; H = 7.52%. Attempts to purify this oil by sublimation and recrystallisation were unsuccessful. The infrared spectrum contained bands at, 3125w, 2994sh, 2950sh, 2882w, 1615w, 1563ms, 1446ms, 1449sh, 1385ms, 1347w, 1290sh, 1250s, 1193m, 1143m, 1064ms, 1010ms, 917m, 847ms, 784m, 760sh, 690w,  $\sim$ 560m. Many of these bands were rather broad and poorly resolved.

## DISCUSSION

A. Attempted Syntheses of the cyclic sulphanic system

The preparation<sup>118</sup> of the most readily accessible sulphanic compound, sulphanic chloride, involves the isolation and pyrolysis of the extremely hygroscopic trichlorophosphazosulphuryl chloride. Further, the impure trichlorophosphazosulphuryl chloride does not pyrolyse to give sulphanic chloride so that, to avoid recrystallisation of the intermediate, the use of pure starting materials is essential. This entails handling of the phosphorus(V) chloride in an inert atmosphere. Other sulphanic compounds are at present only obtainable via metathesis reactions of the chloride. Attempts were, therefore, made to devise alternative syntheses which (i) did not involve such moisture sensitive materials, and (ii) might be more economical on an industrial scale.

(i) Attempted syntheses from trisulphimide salts

The synthesis investigated may be represented as,

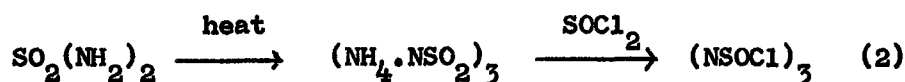

and may be considered to involve two separate aspects which are now discussed.

(a) The preparation of sulphamide

Sulphamide is normally prepared<sup>24-26</sup> by the low temperature (-78°C) reaction between sulphuryl chloride and liquid ammonia. Recently Andreson and Miller<sup>388</sup> have reported good yields (~70%) from a process involving the use of gaseous ammonia at 0°C. Such a process is of considerably greater convenience than that normally used. In this work several attempts to prepare sulphamide by the method of Andreson and Miller resulted in a maximum yield of only ~12%. This result is in agreement with the observations of previous workers<sup>20-23</sup>. It is concluded that high yields of sulphamide can only be obtained by the use of liquid ammonia. However, for the preparation of small amounts (~10g.) of sulphamide the method of Andreson and Miller is convenient.

(b) Reactions of derivatives of trisulphimide

Trisulphimide derivatives are readily obtained from sulphamide. The ammonium salt is formed when sulphamide is subjected to prolonged heating<sup>36-38</sup> at 200°C and metal salts are easily prepared<sup>36</sup> from this compound. Two extreme canonical forms (20) (21) may be written for the trisulphimide anion.

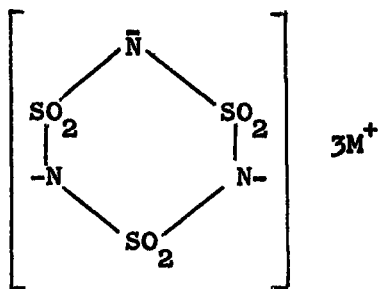

(20)

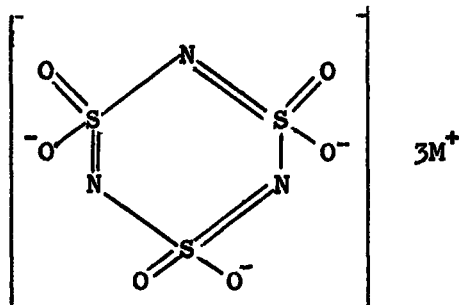

(21)

It is probable that both forms contribute to the structure of the anion. Since the electronegativity of oxygen is greater than that of nitrogen it is to be expected that (21) will make the larger contribution. If (21) is of importance then chlorinating agents may be capable of reacting with this form to give the corresponding acid chloride, viz., sulphanic chloride. Thionyl chloride was chosen as the chlorinating agent in preference to phosphorus(V) chloride since the use of the latter involves the separation of the product from phosphorus oxychloride.

Under the conditions used neither ammonium nor silver trisulphimide underwent reaction with thionyl chloride. However, reaction between ammonium trisulphimide and thionyl chloride did ~~not~~ occur in the presence of dimethylformamide. The product was not desired sulphanic chloride but was an ammonium compound, the infrared spectrum of which was similar to that of the starting material. The formation of this compound suggests that when chlorination does occur it does so in other

than the required manner. Hence, the use of other chlorinating agents was not examined.

The reaction between silver trisulphimide trihydrate and thionyl chloride gave an oil, the infrared spectrum of which contained bands, at  $\sim 3400-3300 \text{ cm}^{-1}$ , attributed to -NH groups. It is suggested that this compound is trisulphimide itself, which is formed as below:

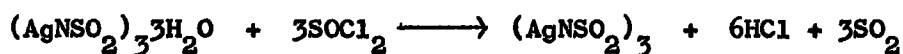

(ii) Reactions between inorganic azides and sulphur-halogen compounds

Various cyclic non-metal-nitrogen compounds may be prepared by thermal decomposition of the appropriate azides. Phosphonitrilic compounds may be obtained from the reaction,<sup>400,401</sup>

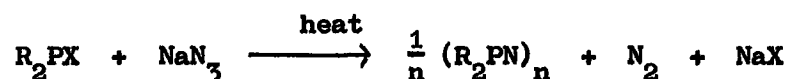

where X = Br, Cl and R = Br, Cl, Ph,  $\text{CF}_3$ . Usually the products are highly polymeric though in some cases<sup>400</sup> the lower polymers can be isolated. Azides of the group IV elements<sup>402</sup> Si, Ge, Sn and Pb are prepared by the general reaction.

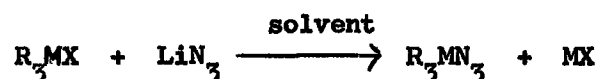

These azides show a relatively high degree of thermal stability due to  $\pi$ -bonding between the central metal atom and the azide group but pyrolysis of the silicon compound,  $\text{Ph}_3\text{SiN}_3$ , gives a high yield of cyclic polymers. Dimesitylboron azide may similarly be prepared<sup>403</sup> from the corresponding fluoride and decomposes to a linear polymer on heating and benzenesulphonyl azide has been prepared<sup>404</sup> by the reaction between sodium azide and benzenesulphonyl chloride.

It was thought reasonable to attempt the synthesis of cyclic sulphur-nitrogen compounds from the appropriate azides. No attempt was made to isolate the azide it being considered preferable to decompose it as formed. By analogy with the examples quoted above the following equations represent possible reactions between thionyl chloride or benzenesulphonyl chloride and sodium azide.

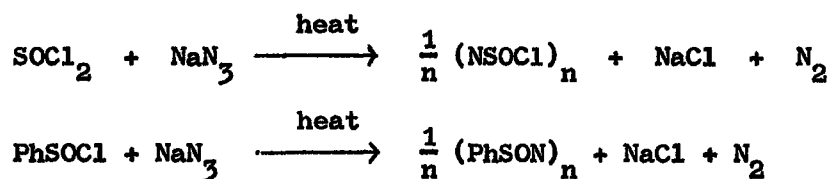

Under the conditions used neither of these reactions occurred.

Trithiazyl trichloride,  $(\text{NSCl})_3$  may be oxidised<sup>114</sup> to sulphanuric chloride so that convenient syntheses of trithiazyl compounds might also afford the corresponding sulphanuric compounds. Accordingly the preparation of  $(\text{NSPh})_3$  was unsuccessfully

attempted via the reaction,

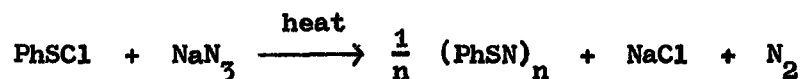

The failure of these sulphur-halogen compounds to react with sodium azide is in marked contrast to the facile reaction that occurs with benzenesulphonyl chloride, and is also surprising in view of the widespread occurrence of the analogous reaction with other elements. It is possible that the azide used is of importance since in the case of the phosphonitric compounds the use of lithium azide rather than sodium azide results in improved yields.

(iii) Reactions between ammonium chloride and sulphur-halogen compounds

The formation of phosphorus-nitrogen and boron-nitrogen cyclic compounds by the reactions between phosphorus(V) chloride<sup>133</sup> or boron trichloride<sup>405</sup> respectively, and ammonium chloride is well known. For the case of phosphorus(V) chloride the reaction may be represented as,

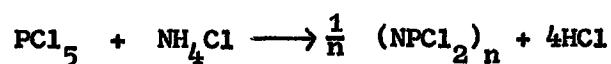

though this simple equation conceals some complexity;

according to the conditions either linear or cyclic compounds can predominate<sup>133</sup>. Maguire *et.al.*<sup>164</sup> and Jolly *et.al.*<sup>165</sup> have studied the reaction between ammonium chloride and sulphur chloride. When an excess of sulphur chloride is used, thiazyl chloride is formed.



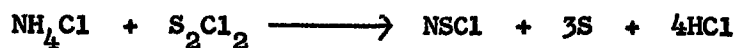

Using excess ammonium chloride thiodithiazyl dichloride results; from reaction between the thiazyl chloride initially formed with more sulphur chloride.



By analogy with the case of P-N or B-N compounds, the equation,



represents a possible reaction between ammonium chloride and thionyl chloride. Attempts to bring about this reaction were unsuccessful.

(iv) The attempted dehydration of sulphonamides by sulphamic acid

Carboxylic acid amides are readily converted into the corresponding nitriles by heating with sulphamic acid<sup>406</sup>

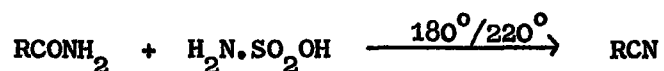

An analogous reaction involving a sulphonamic acid amide would yield a sulphanuric derivative.



Under the conditions examined this reaction did not occur.

**B. The pyrolysis of aryl trichlorophosphazosulphones**

Whilst sulphanuric chloride is prepared by the pyrolysis of trichlorophosphazosulphuryl chloride,  $\text{ClSO}_2\text{N:PCl}_3$ , the pyrolysis of analogous compounds does not appear to have been investigated, though if the reaction occurs in general a wide variety of sulphanuric compounds is readily accessible. Kirsanov<sup>407</sup> has reported that aryl trichlorophosphazosulphones decompose when vacuum distilled but has not examined the decomposition products. Alkyl trichlorophosphazosulphones<sup>408</sup> appear to be thermally more stable in that they can be vacuum distilled without decomposition. Bis(trichlorophosphazo) sulphone is also unstable<sup>409</sup> and decomposes to a considerable extent when vacuum distilled.

If the decomposition of aryl trichlorophosphazosulphones proceeds similarly to that of trichlorophosphazosulphuryl chloride then aryl substituted sulphanuric compounds should result.

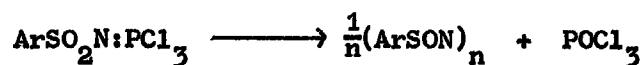

Four compounds,  $\text{XC}_6\text{H}_4\text{SO}_2\text{N:PCl}_3$ , (X = p-CH<sub>3</sub>, p-CH<sub>3</sub>O, p-Cl and m-NO<sub>2</sub>) have been prepared and the pyrolysis of two of these compounds (X = p-CH<sub>3</sub> and p-Cl) has been studied.

In the preparation of these compounds it was observed that the rate of reaction decreased along the series,  $\text{CH}_3\text{O} > \text{CH}_3 > \text{Cl} \gg \text{NO}_2$ . In the original sulphonamide,  $\text{XC}_6\text{H}_4\text{SO}_2\text{NH}_2$ , the extent to which the nitrogen lone pair is involved in  $p_\pi - d_\pi$  bonding to the sulphur atom will vary with the nature of the group X. When X is electron attracting (e.g.  $m\text{-NO}_2$ ) the extent of  $\pi$ -bonding will be greater than when X is electron releasing (e.g.,  $p\text{-CH}_3\text{O}$ ). Since increasing  $\pi$ -bonding effectively decreases the ability of the nitrogen atom to act as a donor, the observed order of relative reaction rates is explained if the first step in the reaction is the formation of a donor-acceptor complex.

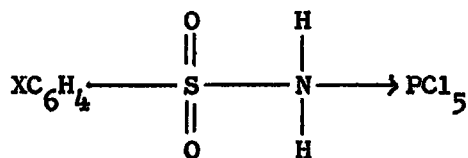

Pyrolysis of *p*-tolyltrichlorophosphazosulphone ~~is~~ resulted in elimination of  $\text{POCl}_3$ , but only to about 50% of the amount required for the formation of the sulphanuric derivative.

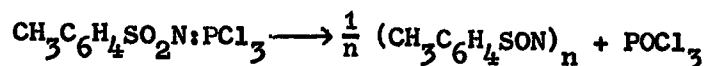

Also formed in the pyrolysis was *p*-tolylsulphonyl chloride,  $\text{CH}_3\text{C}_6\text{H}_4\text{SO}_2\text{Cl}$ . The formation of this compound is thought to result from the elimination of phosphonitrilic chloride, in

accordance with the equation,



The solubilities and infrared spectrum of the black reaction residue suggest it to be a polymeric material, formed by reaction between  $(\text{CH}_3\text{C}_6\text{H}_4\text{SON})_n$  and  $(\text{NPCl}_2)_n$ .

p-Chlorobenzenetrichlorophosphazosulphone is thermally more stable and underwent only slight decomposition during the attempted pyrolysis. That traces of  $\text{POCl}_3$  were obtained, and a strong odour of the sulphonyl chloride was noted, suggests that decomposition occurs in the same way as for the p-tolyl compound.

The mass spectra of these compounds have been recorded and compared with that of trichlorophosphazosulphuryl chloride. The more abundant species observed <sup>are</sup> ~~is~~ given in Tables 11 and 10 respectively. For trichlorophosphazosulphuryl chloride the probable breakdown pattern is given in Fig.18

Fig.18

Mass spectroscopic breakdown pattern of  $\text{ClSO}_2\text{N:PCl}_3$   
 (Routes involving species not observed in the spectrophotometer are shown .....

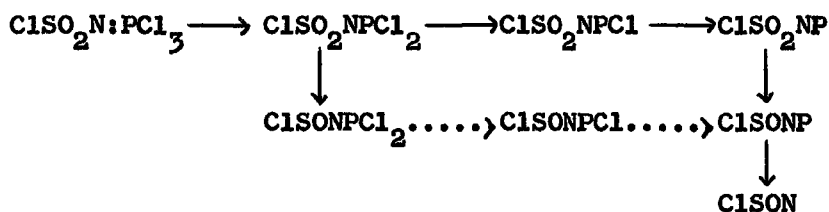

It is significant that this breakdown pattern parallels that obtained on thermal pyrolysis. No peaks which resulted from the early rupture of the ClSON unit were detected. The spectra of the aryl trichlorophosphazosulphones are quite different. The breakdown pattern for all of these compounds is of the type illustrated in Fig.19. The main breakdown route involves

Table 10

Mass spectrum of  $\text{ClSO}_2\text{N}_3\text{PCl}_3$ . Accelerating potential 70ev.  
Source temperature,  $240^\circ\text{C}$ .

Nominal mass	Species	Rel.Int.	
293 } 294 } 295 }	$(\text{NSOCl})_3$	3.5 4.3 2.2	
214 } 216 } 218 } 220 }		$\text{ClSO}_2\text{NPCl}_2$	
			99.7 100.0 43.2 7.9
198 } 200 }	$\text{ClSONPCl}_2$		3.7 2.9
179-183			$\text{ClSO}_2\text{NPCl}$
144	$\text{ClSO}_2\text{NP}$	<2.0	
128	$\text{ClSONP}$	<2.0	
99	$\text{ClSON}$	6.0	
97		2.0	

Masses corresponding to  $\text{SO}_2$ , NSO, SO, NS, Cl and to  $\text{POCl}_3$  and its breakdown products were also observed.

Table 11

Mass spectra of  $\text{XC}_6\text{H}_4\text{SO}_2\text{N:PCl}_3$  compounds. Accelerating potential 70 ev.

Species type	Rel. Int.			
	$\text{CH}_3\text{O}^{1,2}$	$\text{CH}_3^3$	$\text{Cl}^4$	$\text{NO}_2^5$
$\text{XC}_6\text{H}_4\text{SO}_2\text{N:PCl}_3$	29.6	30.3	17.3	10.1
$\text{XC}_6\text{H}_4\text{SO}_2\text{NPCl}_2$	~1.0	2.3	1.4	2.3
$\text{XC}_6\text{H}_4\text{NPCl}_3$	~3.0	12.0	7.3	5.4
$\text{SO}_2\text{NPCl}_3$	~3.0	5.5	9.3	29.7
$\text{SONPCl}_3$	56.0	100.0	100.0	100.0

1,  $\text{CH}_3\text{OC}_6\text{H}_4 = 100$ ,

Source temperature, 2 = 150, 3 = 215, 4 = 225, 5 = 235 °C.

loss of the  $\text{XC}_6\text{H}_4$  fragment to give  $(\text{SO}_2\text{NPCl}_3)^+$  and then the particularly abundant  $(\text{SONPCl}_3)^+$  ion. Breakdown via the alternative route involves, eventually, rupture of the S-N bond. Both routes involve rupture of the  $\text{XC}_6\text{H}_4\text{SON}$  grouping and, therefore, cannot result in the formation of a sulphanuric derivative.

It was concluded that the thermal pyrolysis of a sulphone containing the  $\text{N:PCl}_3$  group is unlikely to lead to a sulphanuric compound unless the mass spectroscopic breakdown of the compound differs from that shown in Fig. 19

Fig.19

Mass spectroscopic breakdown pattern for  $\text{XC}_6\text{H}_4\text{SO}_2\text{N:PCl}_3$  compounds.

Species arising from combination reactions are shown.....

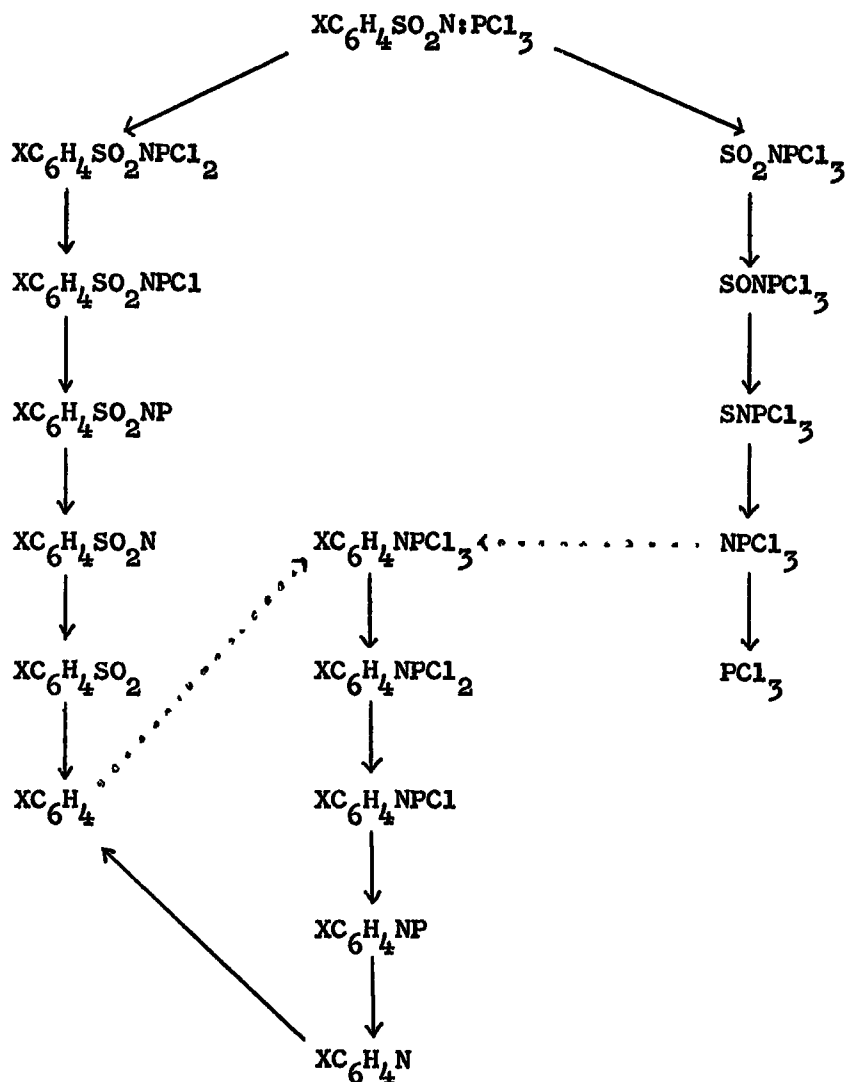

Since thermal pyrolysis of  $p\text{-CH}_3\text{C}_6\text{H}_4\text{SO}_2\text{N:PCl}_3$  resulted in elimination of the  $\text{NPCl}_2$  grouping, the corresponding triphenyl

compound,  $p\text{-CH}_3\text{C}_6\text{H}_4\text{SO}_2\text{N:PPh}_3$ , was prepared. It was thought that elimination of the  $\text{NPPh}_2$  grouping might less readily occur. However, the mass spectrum of this compound showed an analogous breakdown pattern to that observed for chloro compounds, Fig. 19. In view of this the thermal pyrolysis of the compound was not carried out.

The infrared spectra of these compounds have also been recorded. Wiegrabe *et.al.*<sup>378</sup> have reported the spectra of  $p\text{-SH}_3\text{C}_6\text{H}_4\text{SO}_2\text{N:PCl}_3$  and  $p\text{-CH}_3\text{C}_6\text{H}_4\text{SO}_2\text{N:PPh}_3$ ; by analogy with their assignments the spectra of the  $\text{XC}_6\text{H}_4\text{SO}_2\text{N:PCl}_3$  compounds prepared in this work are assigned as in Table 12. There are no marked variations from one compound to another, in particular the  $\nu_{\text{SN}}$  and  $\nu_{\text{SO}_2}$  modes show no systematic variation with the electronic character of the substituent X as expressed by its Hammett  $\sigma$  constant. For all of the compounds strong bands occur at  $\sim 1600$  and  $\sim 1500$  and  $\sim 1450 \text{ cm}^{-1}$  and are assigned<sup>410</sup> to the C=C skeletal in-plane vibrations. For the p-substituted compounds the C-H out-of-plane deformations occur<sup>410</sup> in the normal range,  $860\text{-}880 \text{ cm}^{-1}$ ; the m- $\text{NO}_2$  compound having this mode at  $788 \text{ cm}^{-1}$  (normal range,  $810\text{-}750 \text{ cm}^{-1}$ ). Vibrations involving the substituent X occur in the expected regions. Alkyl aryl ethers<sup>410</sup> show one band at  $1270\text{-}1230 \text{ cm}^{-1}$  corresponding to a C-O vibration, a second band at  $1150\text{-}1060 \text{ cm}^{-1}$  may result from a  $\text{CH}_2\text{-O-}$  vibration.



Aromatic nitro compounds<sup>410</sup> show N-O vibrations in the ranges,  $1527 \pm 16 \text{ cm}^{-1}$  and  $1348 \pm 11 \text{ cm}^{-1}$ . The C-Cl stretching vibration normally occurs<sup>410</sup> in the range  $750\text{-}700 \text{ cm}^{-1}$  but for dichloroethylene and chlorinated aromatic compounds may be as high as  $845 \text{ cm}^{-1}$ .  $p\text{-ClC}_6\text{H}_4\text{SO}_2\text{N:PCl}_3$  shows two absorption modes in this region,  $743$  and  $784 \text{ cm}^{-1}$ . By analogy with the other  $\text{XC}_6\text{H}_4\text{SO}_2\text{N:PCl}_3$  compounds the band at  $743 \text{ cm}^{-1}$  is assigned to  $\nu_{\text{SN}}$  and the band at  $784 \text{ cm}^{-1}$  is tentatively assigned to the C-Cl mode.

Table 12

The infrared spectra of  $\text{XC}_6\text{H}_4\text{SO}_2\text{N:PCl}_3$  compounds

$\nu_{\text{cm}^{-1}}$ \ X	p-CH <sub>3</sub> O	p-CH <sub>3</sub>	p-Cl	m-NO <sub>2</sub>	assignment
	1212	1206	1214	1190	$\nu_{\text{P:N}}$
	754	762	743	745	$\nu_{\text{SN}}$
	1316	1316	1325	1325	$\nu_{\text{as}}^{\text{SO}_2}$
	1152	1150	1152	1148	$\nu_{\text{s}}^{\text{SO}_2}$
	584	590	595	585	$\nu_{\text{s}}^{\text{PCl}}$
	633	621	643	637	$\nu_{\text{as}}^{\text{PCl}}$
	543	541	548	553	$\delta^{\text{SO}_2}$ (scissor)
	513	515	521	510	$\delta^{\text{SO}_2}$ (wag)
			784		$\nu_{\text{CCl}}$
	1266				} $\nu_{\text{CO}}$
	1088				
				1548	} $\nu_{\text{NO}}$
				1353	

The infrared spectrum of  $\text{ClSO}_2\text{N:PCl}_3$  is given in Table 13. The  $\nu_{\text{SN}}$ ,  $\nu_{\text{P:N}}$  and  $\nu_{\text{SO}_2}$  modes occur at frequencies similar to those observed for the aryl trichlorophosphazosulphones. Values of  $\nu_{\text{SN}}$  for both  $\text{ClSO}_2\text{N:PCl}_3$  and the  $\text{XC}_6\text{H}_4\text{SO}_2\text{N:PCl}_3$  compounds suggest<sup>44</sup> that in all of these compounds the S-N bond order is close to unity. This is perhaps surprising since the pyrolysis experiments and mass spectra of these compounds suggest that the S-N bond in  $\text{ClSO}_2\text{N:PCl}_3$  is stronger than that in the  $\text{XC}_6\text{H}_4\text{SO}_2\text{N:PCl}_3$  compounds.

Table 13

The infrared spectrum of  $\text{ClSO}_2\text{N:PCl}_3$

$\nu_{\text{cm}^{-1}}$	assignment
1754m	
1639w	
1538wm	$2 \times \nu_{\text{SN}} = 1532$
1370vs	$\nu_{\text{as}} \text{SO}_2$
1204vs	$\nu_{\text{P:N}}$
1170vs	$\nu_{\text{s}} \text{SO}_2$
766s	$\nu_{\text{SN}}$
720w	
621m	$\nu_{\text{as}} \text{PCl}$
601s	$\nu_{\text{s}} \text{PCl}$
572m	$\delta \text{SO}_2$ (scissor)
535m	$\delta \text{SO}_2$ (wag)
503s	

### 6. $\alpha$ -Sulphanuric chloride as an acceptor molecule

The first reaction in this series, viz the reaction between  $\alpha$ -sulphanuric chloride and pyridine, was initially performed, (a) as part of a general investigation into the chemistry of the sulphanuric system, and (b) as a preliminary experiment to the use of pyridine as an acceptor of HCl in other experiments which involved the elimination of this acid. It being observed that an adduct was formed a more general investigation was made of the acceptor properties of  $\alpha$ -sulphanuric chloride, and then of other sulphur(VI) compounds. These adducts are unusual in that they contain sulphur(VI) at the acceptor site already linked to three <sup>covalent</sup> ~~coordinated~~ nitrogen and each  $\alpha$ -sulphanuric chloride molecule is bonded to three donor molecules.

#### (i) Reactions with tertiary amines

The viscous oils obtained by reaction of  $\alpha$ -sulphanuric chloride with aromatic tertiary amines were insoluble in most solvents but dissolved, with reaction, in the polar solvents dimethylsulphoxide and dimethylformamide. Attempted distillation in vacuo lead to decomposition. Analysis of the products as obtained suggested that these were compounds of the type  $(NSOCl)_3 \cdot 3B$ , where B = pyridine, iso-quinoline. The infrared spectra of these compounds suggest that the sulphanuric ring remains intact;

that of the pyridine adduct (Table 14) is discussed in some detail since the spectra of pyridine complexes have been extensively studied.

$\alpha$ -Sulphanuric chloride itself has strong bands at; (1) 1812m; (2) 1335s, 1326s (doublet); (3)  $\sim$ 1100s (broad); (4) 812m; (5) 713ms; (6) 702ms; (7) 663s; (8)  $\sim$ 540ms (broad)  $\text{cm}^{-1}$ . Corresponding bands in the spectrum of the pyridine adduct were assigned at; (1) 1818w; (2) 1319s, 1300s (doublet); (4) 813ms, 800ms (doublet); (6) 702sh; (7) 658s; (8)  $\sim$ 530ms (broad)  $\text{cm}^{-1}$ . The broad band which appears at  $\sim$ 1100  $\text{cm}^{-1}$  for  $\alpha$ -sulphanuric chloride is difficult to assign for the adduct since it occurs in a region in which pyridine itself shows five strong absorption bands. Whilst the spectrum of  $\alpha$ -sulphanuric chloride is as yet unassigned some of the observed bands are expected to be due to vibrations involving the S-N ring, and hence would be expected to disappear if ring opening occurred.

The changes that occur in the infrared spectrum of pyridine when it functions as a donor have been discussed by several authors.<sup>411-414</sup> In general there is a close similarity between the spectrum of the free base and those of complexes involving metal halides. This has been attributed<sup>412</sup> to back bonding from the d-orbitals of the metal to the  $\pi$ -electron system of the base.

This concept is supported by the more marked changes in the spectra which occur when pyridine is protonated<sup>415</sup> or coordinated to  $BX_3$  compounds<sup>413</sup> since in these systems back coordination cannot occur. The following discussion is based upon the pyridine assignments given by Wilmshurst and Bernstein<sup>416</sup> using the nomenclature of Kline and Turkevitch<sup>417</sup>. The ( $C_{2v}$ ) pyridine molecule has 27 fundamental modes of vibration. Ten modes are in the plane of the ring and are symmetrical with respect to the  $C_{2v}$ -axis (Class A1); nine are in the plane of the ring but are antisymmetrical with respect to the  $C_{2v}$ -axis (Class B1); five modes involve out-of-plane vibrations which are antisymmetric to the two-fold axis (Class B2); and the remaining three symmetrical out-of-plane (A2) modes are forbidden in the infrared. The active modes are numbered 1-20 with suffixes a,b where necessary to distinguish degenerate vibrations.

For pyridine itself (Table 14) the symmetric and antisymmetric in-plane ring deformations occur at 1430-1600  $cm^{-1}$  and these same modes occur at 1480-1640  $cm^{-1}$  for the adduct. These frequency shifts are somewhat greater than those observed for pyridine-metal halide adducts<sup>411</sup> (Table 14) but are comparable with those reported for  $C_5H_5N \cdot BCl_3$ , (8a, 1624; 8b, 1576; 19a, 1540; 19b, 1462  $cm^{-1}$ )<sup>413</sup> and pyridine hydrochloride, (8a, 1631; 8b, 1603;

19a, 1530; 19b, 1481 $\text{cm}^{-1}$ )<sup>415</sup> A new fairly weak band at 1253  $\text{cm}^{-1}$  present in the spectra of neither  $\alpha$ -sulphanuric chloride nor pyridine, is characteristic of pyridine complexes and salts.<sup>411</sup> The region 1200-1000  $\text{cm}^{-1}$  is complex and appears to be a superimposition of the expected five strong pyridine bands and the broad band which occurs at  $\sim 1100 \text{ cm}^{-1}$  for  $\alpha$ -sulphanuric chloride. Assignments (Table 14) in this region are tentative. Other bands at 750, 681 and 609  $\text{cm}^{-1}$  correspond to those which occur at 749, 652 and 605  $\text{cm}^{-1}$  for pyridine itself. A strong band at 569  $\text{cm}^{-1}$ , present in the spectra of neither pyridine nor  $\alpha$ -sulphanuric chloride is in the region expected for a N $\rightarrow$ S bond, (part 2, this thesis). An interesting feature of the spectrum is the presence of a strong, broad, band at  $\sim 2600 \text{ cm}^{-1}$ . If the compound is a simple adduct involving donation of the nitrogen lone pair electrons to vacant sulphur orbitals, then the band must be assigned to a C-H stretching mode. Its low frequency can then be explained as due to involvement of the C-H bond in a hydrogen bond. Alternatively, the band can, in principle, be assigned to a N-H (hydrogen bonded) mode. These two possibilities are now discussed.

(a) That the band at  $\sim 2600 \text{ cm}^{-1}$  is due to a N-H vibration.

For this to be so the compound must have some such structure as (22). Pyridinium compounds normally also show<sup>418,419</sup> non

Table 14

The infrared spectra of  $3(\text{C}_5\text{H}_5\text{N})(\text{NSOCl})_3$  and  $\text{C}_5\text{H}_5\text{N}$ .<sup>416</sup>

$3(\text{C}_5\text{H}_5\text{N})(\text{NSOCl})_3$	$\text{C}_5\text{H}_5\text{N}$	Range observed <sup>411</sup> in complexes ( $\text{cm}^{-1}$ )	assignment
( $\text{cm}^{-1}$ )	( $\text{cm}^{-1}$ )		
3058s	3054		) $\nu_{\text{CH}}$ ) )
3012sh			
2941sh			
388 $\mu$ , 480 $\mu$ 2597s (broad)			
2083m			
1818w			(NSOCl) <sub>3</sub>
1634sh	1583	1578-1615	$\nu_{8a}$
1613s	1572	1562-1576	$\nu_{8b}$
1538s	1482	1471-1490	$\nu_{19a}$
1488s	1439	1436-1461	$\nu_{19b}$
1408w			
1385m	1375		
1319 )			} (NSOCl) <sub>3</sub>
1300 )			
1253m			
1198sh			
1166s	1148	1144-1170	$\nu_{15}$
1122s			
1110sh			
1059s	1030	1035-1047	$\nu_{12}$
1011s	992	1004-1022	$\nu_1$
813 )			} (NSOCl) <sub>3</sub>
800 )			
750	749	741-769	
702sh			(NSOCl) <sub>3</sub>
680	652	645-650	$\nu_{6b}$
658s			(NSOCl) <sub>3</sub>
609m	605	620-641	$\nu_{6a}$ ?
569s			
529ms )			} (NSOCl) <sub>3</sub>
524ms )			

hydrogen bonded N-H modes at  $\sim 3200-3100 \text{ cm}^{-1}$ , not present.

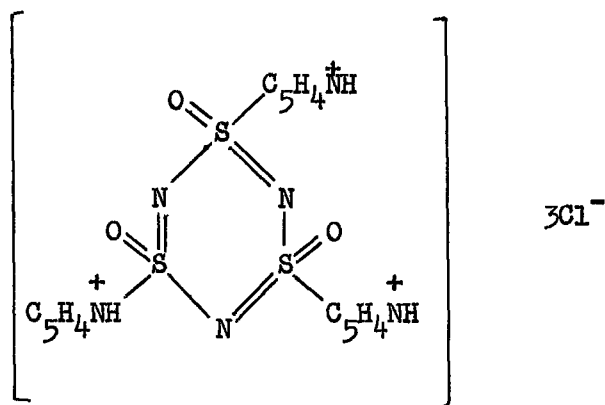

for the adduct and, the band which occurs at  $\sim 540 \text{ cm}^{-1}$  for  $\alpha$ -sulphanuric chloride and at  $\sim 530 \text{ cm}^{-1}$  for the adduct is in the region expected for the S-Cl stretching frequency<sup>340</sup>. Further, attempted metathesis reactions and mass spectroscopic studies reported later indicate that ionisation of the chlorine atoms generally results in ring opening. An ionic compound such as (22) is also expected to be a crystalline material.

(b) That the band at  $\sim 2600 \text{ cm}^{-1}$  is due to a C-H vibration.

Two possible extreme structures arise; (23) represents a simple donor-acceptor adduct and (24) represents a situation in

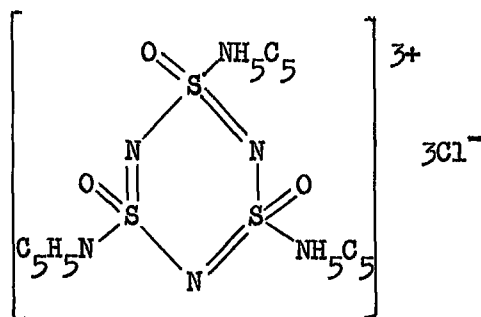
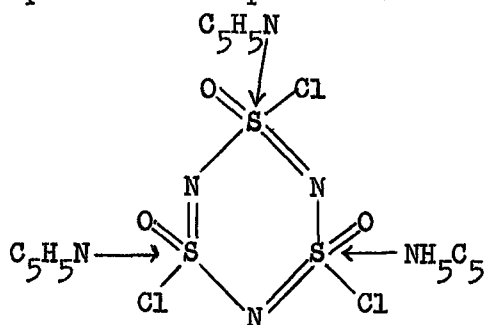



which formation of the adduct is followed by ionisation of the chlorine atoms. Most of the points raised in (a) favour structure (23), though the solubilities of the adduct show it to be a very polar compound which may result, in part, from a highly polar S-Cl bond, i.e. (24) may make an appreciable canonical contribution to the structure. Whilst the spectrum does not allow one to distinguish between C-H...Cl and C-H...O hydrogen bonding the latter is the more likely since hydrogen bonds to oxygen are stronger than those to chlorine,<sup>420</sup> because of the greater electronegativity of the oxygen atom. If the band at  $\sim 2600 \text{ cm}^{-1}$  is assigned to a C-H (hydrogen bonded) mode then the frequency shift, relative to CH in pyridine, is  $\Delta\nu \sim 450 \text{ cm}^{-1}$ . This shift is much greater than those normally associated ( $\Delta\nu \sim 30-100 \text{ cm}^{-1}$ ) with C-H hydrogen bonds.<sup>420, 421</sup> If, as is suggested by the viscosity of the adduct, the hydrogen bonding is intermolecular then it is possible that pairs or arrays of (hydrogen bonded) protons may move in unison. Cooperative movements of this sort give rise to particularly stable hydrogen bonded systems, e.g. Reid<sup>422</sup> has discussed the bonding in  $\text{KH}_2\text{PO}_4$  from this standpoint.

Because of its insolubility, the N.M.R. spectrum of the adduct could not be examined in solution, and its high viscosity causes the spectrum obtained for the compound itself to be ill-defined.

However, the observed spectrum is consistent with the suggestion that hydrogen bonds are present.<sup>420</sup> At 25°C, apart from the normal pyridine triplet, a new broad band appears at low field. Using cyclohexane as an external reference the shift, relative to the C<sub>α</sub> pyridine peak, is ~8.0 p.p.m. This new band moves to higher fields with increasing temperature.

The infrared spectra of the iso-quinoline and trimethylamine adducts are more difficult to assign precisely since much less is reported with regard to the frequency shifts observed when these molecules act as donors. Tentative assignments of the bands due to  $\alpha$ -(NSOCl)<sub>3</sub> in these adducts are given in Table 15. Bands at 610 cm<sup>-1</sup> and 594 cm<sup>-1</sup> in the spectra of the iso-quinoline and trimethylamine adducts, respectively, are assigned to the N→S bonds. The spectra of both compounds show broad bands at ~2600-2500 cm<sup>-1</sup> which are attributed to C-H hydrogen bonds by analogy with the pyridine adduct.

Similar adducts are formed with other donors. With triphenylphosphine the product, which corresponds to 3(Ph<sub>3</sub>P).(NSOCl)<sub>3</sub>, was a sticky semi-solid material the infrared spectrum of which could not be obtained as it was impossible to prepare a satisfactory mull. The adduct was insoluble in non-polar solvents but when dissolved in nitromethane decomposed to give triphenylphosphine dichloride.

Table 15

Bands assigned to  $\alpha$ -(NSOCl)<sub>3</sub> in iso-quinoline and trimethylamine adducts ( $\nu$ cm<sup>-1</sup>)

$\alpha$ -(NSOCl) <sub>3</sub>	3(C <sub>9</sub> H <sub>7</sub> N)(NSOCl) <sub>3</sub>	3 [(CH <sub>3</sub> ) <sub>3</sub> N](NSOCl) <sub>3</sub>
1335s )	1342sh )	1330s )
1326s )	1297s )	1312s )
~1100s	1120s	1076s
812m		
713ms		722wm
702ms	700sh	690m
666s	683s	
~540ms	~530m	~515ms

Infrared spectra were obtained for the triphenylarsine, 3Ph<sub>3</sub>As.(NSOCl)<sub>3</sub> and triphenylstibine, 3Ph<sub>3</sub>Sb.(NSOCl)<sub>3</sub> adducts and bands due to  $\alpha$ -(NSOCl)<sub>3</sub> are given in Table 16. All other bands in the spectra of these compounds corresponded to those expected for the donor molecules.<sup>423</sup> In contrast to the amine adducts no bands were observed at  $\sim 2600$  cm<sup>-1</sup>. The triphenylstibine adduct, in contrast to those of phosphorus and arsenic, is a solid compound. The preparation of this compound also resulted in the formation of triphenylstibine dichloride.

Table 16

Bands assigned to  $\alpha$ -(NSOCl)<sub>3</sub> in triphenylarsine and triphenylstibine adducts ( $\nu$ cm<sup>-1</sup>)

$\alpha$ -(NSOCl) <sub>3</sub>	$3\text{Ph}_3\text{As}(\text{NSOCl})_3$	$3\text{Ph}_3\text{Sb}(\text{NSOCl})_3$
1335s )	1342sh )	1333m )
1326s )	1335s )	1285s )
~1100s	1110s	1110sh
812m	804ms	805wm
713ms		
702ms	697sh	694sh
666s	632m	631wm
~540ms	~550m	~550w

#### D. Other sulphur(VI) compounds as acceptor molecules

As a result of the formation of the  $\alpha$ -sulphanuric chloride adducts (above) in which it is suggested that sulphur(VI) functions as the acceptor site, the possibility that other sulphur(VI) compounds behave similarly has been investigated. It was thought that a study of the properties of any such compounds might provide further evidence concerning the structures of the  $\alpha$ -sulphanuric chloride adducts.

Adducts of sulphur trioxide with organic bases are well known<sup>424</sup> though little attention has been paid to the structures of these

adducts. Watari<sup>425</sup> has reported the infrared spectrum of  $\text{Me}_3\text{N}\cdot\text{SO}_3$ ; the frequencies calculated assuming  $\text{C}_{3v}$  symmetry are in good agreement with those observed. The order of the N-S bond is computed as 0.68 so that the compound appears to be a true donor-acceptor complex. These compounds appear to be the only reported examples where sulphur(VI) functions as an acceptor.

Baumgarten<sup>426</sup> has reported that pyridine reacts with sulphuryl chloride to give a complex, oily, product which is thought to contain  $(\text{C}_5\text{H}_5\text{NCl})\text{SO}_2\text{Cl}$  and  $(\text{C}_5\text{H}_5\text{NCl})_2\text{SO}_2$ . This reaction has been repeated in order that the infrared spectrum of the product might be examined. The viscous, oily, product corresponded to  $2(\text{C}_5\text{H}_5\text{N})\text{SO}_2\text{Cl}_2$  irrespective of the mole ratio of the reactants. The infrared spectrum is complex and is difficult to assign with any precision. However, it is characteristic of coordinated rather than salt-like pyridine<sup>411</sup>. The symmetric and asymmetric S-O stretching modes occur at 1403 and 1182  $\text{cm}^{-1}$ , respectively compared to 1414 and 1182  $\text{cm}^{-1}$  for sulphuryl chloride itself<sup>427</sup>. As with the  $\alpha$ -sulphanuric chloride adducts a strong broad band occurs at  $\sim 2500 \text{ cm}^{-1}$  and is thought to be due to C-H hydrogen bonding. By analogy with the  $\alpha$ -sulphanuric chloride derivatives it is suggested that the oil initially formed is a simple adduct. However, on standing (>24 hours) the oil appears to decompose with loss of  $\text{SO}_2$ , possibly in a complex manner as suggested by Baumgarten.<sup>426</sup>

Because of the presence of the band at  $\sim 2500 \text{ cm}^{-1}$  it was decided to prepare the pyridine-sulphur trioxide and pyridine-selenyl chloride complexes in order to examine the infrared spectra of these compounds.

Whilst the infrared spectrum<sup>425</sup> of the  $\text{Me}_3\text{N}\cdot\text{SO}_3$  complex does not show a band at  $\sim 2500 \text{ cm}^{-1}$ , it was felt that an aromatic amine complex might behave differently. Further, if for the pyridine complex the band at  $\sim 2500 \text{ cm}^{-1}$  were observed, this would suggest that the hydrogen bonding involved the C-H...O system. The selenyl chloride complex,  $2(\text{C}_5\text{H}_5\text{N})\cdot\text{SeOCl}_2$ , whilst not completely analogous to the sulphur(VI) adducts, was thought to be of interest in view of its peculiar structure. This compound, which has a tetragonal pyramidal structure,<sup>428</sup> contains two long, 2.57 and 2.39 Å, Se-Cl bonds (calculated, 2.16 Å). The longer bond is thought to be due to a bridging chlorine which approaches the unfilled octahedral position in a neighbouring molecule. However, if in the sulphur(VI) adducts the band at  $\sim 2600 \cdot 2500 \text{ cm}^{-1}$  is due to the C-H...Cl system, then a similar situation might exist in this compound, for which the infrared spectrum does not appear to have been reported. The infrared spectrum is given in Table 17. The band at  $1250 \text{ cm}^{-1}$  is characteristic of coordinated pyridine<sup>411</sup>. The band at  $920 \text{ cm}^{-1}$  is assigned to  $\nu \text{Se-O}$  which in selenyl chloride<sup>429</sup> itself occurs

Table 17

The infrared spectrum of  $2(C_5H_5N) \cdot SeOCl_2$ 

$\nu$ $cm^{-1}$ assignment	$\nu$ $cm^{-1}$ assignment
3086m )	920vs $\nu$ Se-O
3058m ) $\nu$ CH	879s $\nu$ 10b
3021m )	762vs $\nu$ 4
2994w	746sh
1919w	699sh
1880w	682vs $\nu$ 11
1694w	634vs $\nu$ 6b
1634m $\nu$ 8a	621sh $\nu$ 6a
1597vs $\nu$ 8b	590ms
1572s	423ms $\nu$ 16b
1527w	329s $\nu$ as Se-Cl
1477s $\nu$ 19a	298s $\delta$ s ClSeCl
1449vs $\nu$ 19b	$\nu$ 220s $\delta$ as OSeCl
1351wm $\nu$ 14	
1250m	
1203s $\nu$ 9a	
1155s $\nu$ 15	
1058vs $\nu$ 18a	
1030vs $\nu$ 12	
1006vs $\nu$ 1	

at  $995\text{ cm}^{-1}$ . Bands in the region  $450\text{--}200\text{ cm}^{-1}$  are tentatively assigned by analogy with selenyl chloride<sup>429</sup> for which  $\nu_{\text{as}}\text{Se-Cl}$ ,  $\delta_{\text{g}}\text{ClSeCl}$  and  $\delta_{\text{as}}\text{OSeCl}$  occur at 347, 279 and  $255\text{ cm}^{-1}$  respectively. In the region  $770\text{--}620\text{ cm}^{-1}$  all of the strong bands are associated with pronounced shoulders and the assignments are tentative.

The mass spectrum of this compound showed only peaks due to pyridine, Se and SeO. It seems that simple breakdown into the two components occurs. That peaks due to  $\text{SeOCl}_2$  and  $\text{SeOCl}$  are not observed is reminiscent of the behaviour of  $\text{SOCl}_2$  for which the parent peak is insignificant, and that due to  $\text{SOCl}$  is of low intensity<sup>102</sup>.

The infrared spectrum of the pyridine-sulphur trioxide complex is given in Table 18. The band at 132 is characteristic of coordinated pyridine<sup>411</sup>. A doublet at  $1304, 1299\text{ cm}^{-1}$  and the band at  $1075\text{ cm}^{-1}$  are assigned to  $\nu_{\text{as}}\text{S-O}$  and  $\nu_{\text{g}}\text{S-O}$  respectively, these modes occur at  $1330\text{ cm}^{-1}$  and  $1069\text{ cm}^{-1}$  for the trioxide itself<sup>330</sup>. The doublet at  $658\text{--}676\text{ cm}^{-1}$  is difficult to assign since both pyridine ( $652\text{ cm}^{-1}$ ) and sulphur trioxide ( $652\text{ cm}^{-1}$ ) absorb in this region, which may also contain  $\nu_{\text{S-N}}$ . The spectrum seems to be as expected for a simple adduct and it is suggested that this form of the compound is a true donor-acceptor complex.

The pyridine-sulphur trioxide complex is difficult to purify because of its insolubility<sup>424</sup> in most solvents. The compound was dissolved in nitromethane, at room temperature, and the solution



Table 18

The infrared spectra of the two compounds,  $C_{55}H_{55}N.SO_3$ 

$\alpha$ ( $\nu$ $cm^{-1}$ )	assignment	$\beta$ ( $\nu$ $cm^{-1}$ )	$\alpha$ ( $\nu$ $cm^{-1}$ )	assignment	$\beta$ ( $\nu$ $cm^{-1}$ )	
3125s	} $\nu_{CH}$	3178m			919ms	
3086m		3106sh	879w		889sh	
3058w			844w		858w	
2915w					794vs	
1631m	$\nu_{8a}$	1639sh	781s		784vs	
1613s	$\nu_{8b}$	1616s	753m	$\nu_4$	731vs	
1577w			685vs		681vs	
1529m		1536s			652w	
1477m	$\nu_{19a}$	1490s	676s		613s	
1462s	$\nu_{19b}$				588sh	
1426w			599vs	$\nu_{6a}$	575vs	
1385w	$\nu_{14}$	} 1342sh	561s	$\delta_d S-O$		
1304vs	$\nu_{as} S-O$					506ms
1299vs						
1269m		1274vs				
1232m		1220sh				
1207m	$\nu_{9a}$					
1156m	$\nu_{15}$	1190s				
1099w		1170sh				
1075vs	$\nu_s S-O$	1086s				
1062m	$\nu_{18a}$	1058s				
1043ms	$\nu_{12}$	1038s				
1031w						
1017ms	$\nu_1$	1011ms				

allowed to stand at this temperature for several hours.

Needle like crystals were slowly deposited and analysis showed the molecular formula still to be  $C_{55}H_{55}N \cdot SO_3$ . It seems, therefore, that this compound can exist in two solid forms ( $\alpha$  and  $\beta$ ). The infrared spectrum of the second ( $\beta$ ) form is also given in Table 18 and is more complex than that of the ( $\alpha$ ) form first isolated. The regions 1300-1150, 800-730 and 590-570  $cm^{-1}$  contain broad complexes absorptions; it seems probable that in this  $\beta$  form the pyridine is bonded through oxygen, or that the sulphur trioxide is present in a polymeric form.

The mass spectra of both forms of  $C_{55}H_{55}N \cdot SO_3$  were identical. In each case simple decomposition into the constituents,  $C_{55}H_{55}N$  and  $SO_3$ , occurred. In this respect these compounds resemble the selenyl chloride adduct,  $2(C_{55}H_{55}N) \cdot SeOCl_2$ .

In conclusion, a study of the adducts,  $C_{55}H_{55}N \cdot SO_3$  and  $2(C_{55}H_{55}N) \cdot SeOCl_2$ , has revealed no evidence for C-H hydrogen bonding in these compounds. However, they do illustrate the general infrared and mass spectroscopic behaviour which is to be expected for simple donor-acceptor adducts.

The reactions of sulphuryl chloride with other donors has also been investigated. With triphenylphosphine two compounds, a colourless oil and a white amorphous solid were isolated; the

analyses for each compound indicated a molecular structure,  $\text{Ph}_3\text{P}\cdot\text{SO}_2\text{Cl}_2$ . On the basis of the infrared spectra of these compounds it is thought that both are simple adducts, the oil containing the ligand bonded to the sulphur atom, whilst in the solid the ligand is bonded to one of the oxygen atoms. The infrared spectra are given in Table 19; as is that of  $\text{Ph}_3\text{P}$  itself. For the oil the strong broad band at  $1279\text{ cm}^{-1}$  is assigned to  $\nu_{\text{as}}^{\text{S-O}}$  and appears to obscure the weak absorption at  $1274\text{ cm}^{-1}$  of triphenylphosphine itself. This mode occurs<sup>427</sup> at  $1414\text{ cm}^{-1}$  in  $\text{SO}_2\text{Cl}_2$  itself. This rather large shift ( $\Delta\nu = 135\text{ cm}^{-1}$ ) is probably due, in part, to the high mass of the ligand though other factors must also be involved since mass effects do not normally result in changes of this magnitude. Bands at  $1106$  and  $578\text{ cm}^{-1}$  correspond to the  $\nu_{\text{g}}^{\text{S-O}}$  and  $\text{SO}_2$  bending modes which occur<sup>427</sup> at  $1182$  and  $560\text{ cm}^{-1}$  for  $\text{SO}_2\text{Cl}_2$  itself. All of the other bands observed correspond to those of the free ligand.

In the case of the solid the strong ( $\nu_{\text{as}}^{\text{S-O}}$ ) band which occurs at  $1279\text{ cm}^{-1}$  for the oil has disappeared, and the band at  $1263\text{ cm}^{-1}$  is thought to correspond to the weak  $1274\text{ cm}^{-1}$  band of triphenylphosphine. The strong band at  $1006\text{ cm}^{-1}$  is assigned to an S-O stretching vibration and that at  $565\text{ cm}^{-1}$  to an  $\text{SO}_2$  bending mode. The new band at  $656\text{ cm}^{-1}$  (not present for the oil) is thought to be due to a vibration involving the S-O- $\text{PPh}_3$  group. The

remaining bands correspond to those observed for the free ligand, though the bands at 1031 and 996  $\text{cm}^{-1}$  appear to be reversed in intensity as compared with those at 1023 and 996  $\text{cm}^{-1}$  for  $\text{Ph}_3\text{P}$  itself.

Table 19

The infrared spectra of the  $\text{Ph}_3\text{P}\cdot\text{SO}_2\text{Cl}_2$  adducts

oil ( $\nu$ $\text{cm}^{-1}$ )	$\text{Ph}_3\text{P}$ ( $\nu$ $\text{cm}^{-1}$ )	solid ( $\nu$ $\text{cm}^{-1}$ )	oil ( $\nu$ $\text{cm}^{-1}$ )	$\text{Ph}_3\text{P}$ ( $\nu$ $\text{cm}^{-1}$ )	solid ( $\nu$ $\text{cm}^{-1}$ )
1582s	1582ms	1580s	617s	617wm	616s
		1570sh	578s		565s
1493s			536vs	539w,	535m
1481s	1472vs	1479s	513s	511s	513ms
1435vs	1431vs	1438vs			
	1370w				
1322sh	1324w	1342wm			
1312sh	1305ms	1314ms			
1279vs	1274w	1263s			
1185wm	1176wm	1188wm			
1163wm	1153wm	1161wm			
1120sh	1117w	1145w			
1106vs		1107vs			
1096sh	1088s	1099s			
1077w	1068m	1072w			
1040vs	1023s	1031w			
1026w					
993w	994m	996s			
935w	916wm				
	853w	853w			
	752s	760vs			
749s	746s	747vs			
729vs	741s	727vs			
696s	695s	697sh			
685s	691s	690s			
		699sh			
		656s			

Since the adduct is initially obtained as the oil, which then largely isomerises to the solid, it would seem that the O-bonded form is slightly the more stable. Mass spectroscopic

studies support this suggestion. The mass spectra of both isomers are identical and correspond to cleavage of the adduct into triphenylphosphine oxide and thionyl chloride.

Attempts to prepare a 2:1 adduct,  $2(\text{Ph}_3\text{P})\cdot\text{SO}_2\text{Cl}_2$ , were unsuccessful, in contrast to the reaction with pyridine when only the 2:1 adduct could be obtained.

With triphenylarsine and triphenylstibine simple adducts were not isolated, but the dichlorides,  $\text{Ph}_3\text{AsCl}_2$  and  $\text{Ph}_3\text{SbCl}_2$  were obtained in almost quantitative yields. It seems probable that these compounds were obtained via the initial formation of an adduct, which then decomposed with elimination of  $\text{SO}_2$ , e.g.

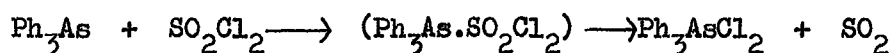

The preparation of these dichlorides in this manner does not appear to have been previously reported, and is more convenient than the normal preparation by the action of chlorine on the triphenyl derivative.

Attempts to prepare adducts with other sulphur(VI) compounds, aryl sulphonamides and sulphonyl chlorides, diphenylsulphone and sulphamide, were unsuccessful. The compound  $(\text{C}_5\text{H}_5\text{N}\cdot\text{SO}_2\text{Ph})\text{Cl}$  has been reported<sup>430</sup> but could not be obtained in this work. The reaction between benzenesulphonyl chloride and triphenylphosphine gave triphenylphosphine oxide and, presumably, benzenesulphinyl chloride, though this was not isolated. Brzozowski<sup>431</sup> has reported the preparation of a variety of amine complexes with sulphonamides

containing acyl substituents. These compounds are thought to contain the amine bonded via the carbon of the acyl group, except in the case of sulphonyl guanidines for which bonding via the sulphur of the  $\text{SO}_2$  group is postulated. The author has unsuccessfully attempted to prepare adducts of pyridine with benzene- and pentafluorobenzene-sulphonamides. Whilst in the latter case only the starting materials could be recovered, the formation of a strong colour on mixing the reactants suggests that an unstable adduct may have been formed in solution.

It seems that adducts can only be prepared for sulphur(VI) compounds in which the sulphur atom is surrounded by four highly electronegative ligands. For such compounds the energies of the unfilled sulphur d-orbitals are lowered by the presence of the substituents<sup>357</sup> and it seems reasonable to assume that it is these orbitals which accommodate the donor electrons. Adducts of  $\alpha$ -sulphanuric chloride are more stable than those of sulphuryl chloride. Thus,  $\alpha$ -sulphanuric chloride forms adducts with  $\text{Ph}_3\text{As}$  and  $\text{Ph}_3\text{Sb}$  (though the latter is rather unstable) whilst sulphuryl chloride does not form adducts with these weaker ligands. Again,  $\alpha$ -sulphanuric chloride forms stable adducts with both aromatic and aliphatic tertiary amines, whilst sulphuryl chloride-aromatic amine adducts seem rather unstable and with aliphatic amines no simple adduct is formed (see later). A possible explanation is that

for the  $\alpha$ -sulphanuric chloride adducts the donor electrons are accommodated in molecular orbitals which, to some extent, are delocalised over the sulphur-nitrogen ring.

E. Similar complexes of amines with elements other than sulphur

If the above hypothesis is correct then compounds of other covalently saturated main group element (X) containing low-lying d-orbitals should also be capable of forming adducts. In particular, if X = O or X - Cl bonds are present the resultant compounds may <sup>contain</sup> C-H hydrogen bonds. Phosphorus oxychloride seemed to satisfy the requirements and the formation of an adduct,  $2(C_5H_5N).POCl_3$ , has been reported<sup>399</sup>. The preparation of this compound was attempted in order that its infrared spectrum might be examined. Under anhydrous conditions it was only possible to isolate traces of pyridinium chloride. However, using unpurified reagents a product was obtained for which the analyses were approximately those required for the adduct. The m.p. of this product (50-70°C) indicate it to be impure and it is thought to be a mixture of pyridine salts of phosphorus oxychloride hydrolysis products.

Complexes of acyl halides with pyridine and other tertiary bases have been examined by Paul and Chadha<sup>432</sup> who have proposed structures such as (25) because of the presence of a band at 2300-2100  $cm^{-1}$

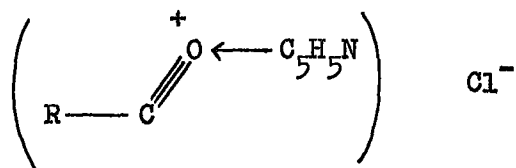

(25)

which they assign to the  $\text{C}\equiv\text{O}^+$  group.

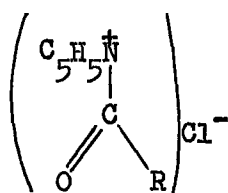

(26)

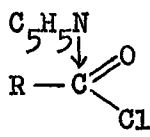

(27a)

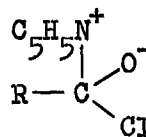

(27b)

Because of the high electronegativity of the oxygen atoms it seems likely that the positive charge in the  $(\text{RCO})^+$  ion will be largely associated with the acyl carbon atom. It is thought, therefore, that these complexes are more likely to have structures such as (26) and (27), which involve bonding via the acyl carbon atom. These structures are analogous to those proposed for the  $\alpha$ -sulphanuric chloride-amine adducts, (23) and (24), and may be regarded as extreme possibilities representing the formation of salts (26) or donor-acceptor complexes (27). Structure (27a) which requires four-covalent carbon to act as an acceptor site is unlikely but it can be alternatively written as (27b) in which form it may make a canonical contribution.



The spectra of these acyl halide-amine complexes show a strong broad band at  $2700 \text{ cm}^{-1}$  which is assigned by Paul and Chadha<sup>432</sup> to a C-H stretching mode, but with no explanation as to its low frequency<sup>1</sup>. On the basis of structures (26) and (27) this may be explained as due to C-H hydrogen bonding, as in the case of the sulphur(VI) adducts.

F. The amine adducts and dimethylsulphoxide

The reaction between  $3(\text{C}_9\text{H}_7\text{N})(\text{NSOCl})_3$  and dimethylsulphoxide gave a compound for which the analyses corresponded to,  $2(\text{C}_9\text{H}_7\text{N}) \cdot (\text{CH}_3)_2\text{SO} \cdot (\text{NSOCl})_3$ , i.e. one iso-quinoline ligand was replaced by dimethylsulphoxide. The assignment of  $\nu_{\text{S-O}}$  in complexes containing dimethylsulphoxide is the subject of some controversy, as has been discussed in part 2 of this thesis. For this compound the infrared spectrum is complex and the band expected at  $\sim 1000 \text{ cm}^{-1}$  is in a region where pyridine itself absorbs strongly. A new strong band at  $910 \text{ cm}^{-1}$  may be assigned to either the S-O stretching or the  $\text{CH}_3$ -rocking vibration. It seems probable that the dimethylsulphoxide is bonded through its oxygen atom as in most other complexes. Dimethylsulphoxide also reacted with the pyridine adduct to give a compound the infrared spectrum of which was similar to that of the mixed iso-quinoline-dimethylsulphoxide adduct.

G. The pyrolysis of the amine adducts

All of these compounds decomposed when heated at 100°C under vacuum. In the case of the adduct,  $2(C_5H_5N).SO_2Cl_2$ , analysis of the product indicated a molecular formula,  $C_5H_{4-6}NOCl$ , but did not precisely fix the number of hydrogen atoms present (Table 20).

Table 20

Analysis of the  $2(C_5H_5N).SO_2Cl_2$  pyrolysis product

	Calculated (%)			Found (%)
	$C_5H_4NOCl$	$C_5H_5NOCl$	$C_5H_6NOCl$	
C	46.35	45.99	45.64	46.24
H	3.12	3.87	4.61	4.98
N	10.81	10.72	10.65	10.71
Cl	27.37	27.16	26.95	28.05

The infrared spectrum was characteristic of the pyridinium ion<sup>411</sup> and, with the exception of two moderately strong bands at 1104 and 814  $cm^{-1}$  was identical with that of pyridinium chloride.

The N.M.R. spectrum in nitromethane was identical with that of pyridinium chloride in the same solvent. Alkaline hydrolysis liberated pyridine though, in contrast, the mass spectrum contained peaks at masses (113, 115) corresponding to  $C_5H_4NCl$ .

It has not been possible to suggest a completely satisfactory structure for this compound. The molecular formula  $C_5H_5NOCl$  was rejected since it requires an odd-electron molecule. For the species  $C_5H_4NOCl$  and  $C_5H_6NOCl$  various structures (28-30) may be written.

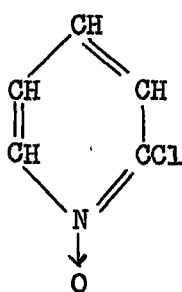

(28)

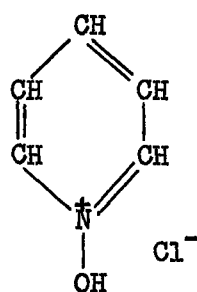

(29)

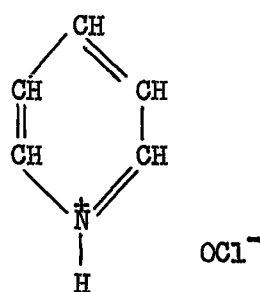

(30)

Structures (28) and (29) involving N-O bonds seem plausible by analogy with the O-bonded form of the  $Ph_3P \cdot SO_2Cl_2$  complex, though (28) is unlikely since it requires the hydrolysis product to be an hydroxypyridine. On the basis of structures (29) and (30) it is difficult to account for the presence of  $C_5H_4NCl$  in the mass spectrum. The mass spectrum of  $C_5H_5N \cdot HCl$  shows only peaks due to  $C_5H_5N$  and  $HCl$  so that, as expected, the  $Cl^-$  ion is not capable of chlorinating the pyridine nucleus under the conditions used in the spectrophotometer. However, the hypochlorite ion is a stronger chlorinating agent and it is perhaps possible that, at the temperatures used ( $\sim 200^\circ C$ ),

thermally induced chlorination could occur before the sample volatilised into the ion source.

The formulation of this pyrolysis product as a pyridine salt receives some support from the reaction between triethylamine and sulphuryl chloride from which only triethylamine hydrochloride could be isolated. However, evaporation of the solution to dryness gave traces of a red-brown oil which suggests that an unstable adduct may have been formed initially. A similar situation occurs in the reactions of thionyl chloride with pyridine and some other tertiary bases<sup>102</sup> which also yield only the amine hydrochlorides.

The pyridine and iso-quinoline adducts of  $\alpha$ -sulphanuric chloride appear to decompose in an analogous manner to the pyridine-sulphuryl chloride adducts. The products appear to have molecular structures  $C_5H_6NSCl$  and  $C_9H_8NSCl$  i.e, they are thio-analogues of the product from the pyridine-sulphuryl chloride adduct, and presumably, have analogous structures.

#### H $\pi$ -Complexes of $\alpha$ -sulphanuric chloride

$\alpha$ -Sulphanuric chloride reacts with excess hexamethylbenzene to give a compound for which the analyses correspond approximately to,  $2(C_6Me_6).(NSOCl)_3$ . Attempts at purification lead to decomposition with the formation of a red-brown solid which was similar in appearance to that obtained from reactions using a

lower proportion of hexamethylbenzene. It seems possible that this red-brown solid is an impure, unstable 1:1 adduct,  $C_6Me_6 \cdot (NSOCl)_3$ .

Similar products are formed, in the solid phase, by the amino- and chloro-cyclophosphazenes<sup>433</sup>. The chlorocyclophosphazenes are strong acceptors towards hexamethylbenzene. The cyclo-tri- and penta-phosphazenes each form only a 2:1 complex, e.g.  $2(C_6Me_6) \cdot (NPCl_2)_3$ ; the cyclo-tetra- and hexa-phosphazenes form both 2:1 and 1:1 adducts.

#### I. $\alpha$ -Sulphanuric chloride as a donor molecule

These experiments were carried out as part of a general examination of the chemical properties of  $\alpha$ -sulphanuric chloride. In principle  $\alpha$ -sulphanuric chloride may function as an electron donor via (i) the ring nitrogen atoms (ii) the exocyclic oxygen atoms and (iii) the delocalised  $p_\pi - d_\pi$  ring orbitals.

(i) the ring nitrogen atoms

Other cyclic sulphur-nitrogen systems form adducts in this manner. Thus  $(NSF)_4$  forms<sup>106</sup> the weak adduct  $(NSF)_4 \cdot BF_3$  and  $S_4N_4$  forms adducts<sup>96-101</sup> with a variety of metal-halides, e.g.,  $S_4N_4 \cdot SbCl_5$  for which structural studies<sup>434</sup> show the presence of a Sb-N bond.

## (ii) The exocyclic oxygen atoms

Such behaviour, though less likely than (i), would be analogous to that of dimethylsulphoxide which forms numerous adducts with metal halides<sup>300-308</sup>.

(iii) The  $\pi$ -delocalised system

Such behaviour is unusual, however, it has been suggested<sup>435</sup> that this type of bonding occurs in the complex  $(NMe_2)_4.Mo(CO)_4$ .

---

Attempts to form adducts with beryllium and mercury(II)-chlorides were unsuccessful. More promising results were obtained with transition metal halides. The colour changes which occur with both  $TiCl_4$  and  $NbCl_5$  suggest that some interaction, possibly weak charge transfer, occurs. However, in both cases the initial product decomposed on standing at room temperature. It is possible that an examination of these reactions at lower temperatures would lead to isolation of complexes. However, it may be more desirable to examine the donor properties of other, particularly amino, sulphanic derivatives. Thus, it has been shown that the phosphonitrilic chlorides are only weakly basic<sup>436,437</sup> and do not interact with metal halides<sup>438</sup>. In contrast the amino phosphonitriles<sup>439,440</sup> are more strongly basic and form complexes with Co(II), Cu(II) and Ni(II) ions<sup>438</sup>. It has been suggested<sup>438</sup>

that this difference may result from the ability of the halide atom to decrease ring electron density. Analogously, though benzene acts as a Lewis base,  $C_6F_6$  is a Lewis acid<sup>441</sup>. Electron donor substituents such as amines may have the opposite effect and, therefore, enhance the donor capacity of the ring or the ring nitrogen atoms. Similar arguments may apply in the case of sulphanuric compounds.

#### J. Metathesis reactions of $\alpha$ -sulphanuric chloride

One aim of the research was to attempt the preparation of a series of sulphanuric compounds,  $(NSOX)_3$ , and to investigate the properties of these compounds utilising, e.g., infrared N.M.R. and mass spectroscopy and measurement of dipole moments in solution. It was hoped that in this way the stability of the compounds could be shown to be related to the nature of the substituent X.

Reactions with lithium alkyls lead to the formation of compounds whose infrared spectra bore no resemblance to those of sulphanuric chloride or other sulphanuric derivatives<sup>125, 127</sup>. In an attempt to prepare the triphenyl derivative,  $(NSOPh)_3$ , by reaction with phenylmagnesium bromide only a small amount of an oil was isolated. The infrared spectrum of this oil was almost identical with that reported for phenyl thionylimine,  $PhNSO$ . The analyses were quite close to those required and it was concluded

that the oil was impure PhNSO. Presumably the phenylmagnesium bromide added initially across the S=O double bond and this was followed by ring opening and rearrangement.

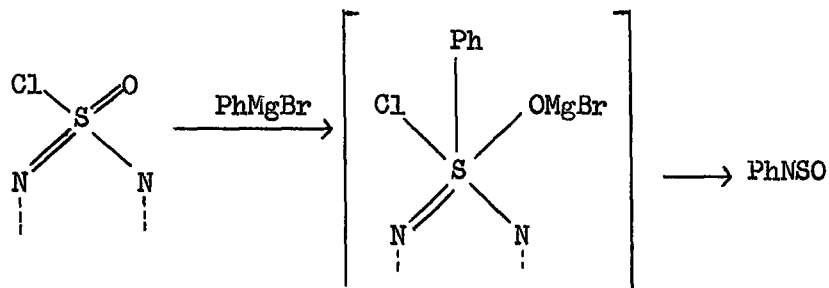

The low yield of PhNSO suggests that other modes of breakdown also occur. Attempts to prepare the mono-phenyl derivative in like manner apparently resulted in a similar ring cleavage. The product obtained by extraction of the crude reaction residue with acetonitrile was analysed for C,H,N and S which were found to account for only 46% of the compound. Qualitative tests showed the presence of magnesium, chlorine and bromine. Analysis for total halogen in conjunction with the elemental analyses suggested that the material could best be represented as  $(\text{PhNSO})_2 \cdot 2(\text{CH}_3\text{CN}) \cdot \text{Mg}_2\text{BrCl}_2$ . The infrared spectrum could be rationalised on the assumption that both PhNSO and  $\text{CH}_3\text{CN}$  were present; the  $\text{C}\equiv\text{N}$  mode occurs at  $2288 \text{ cm}^{-1}$  which is characteristic of the nitrile group acting as a donor to a rather weak acceptor.<sup>369-370</sup> No reasonable structure could be postulated for molecular formula and it was concluded that the material was probably a mixture of PhNSO and a



magnesium halide - acetonitrile adduct. It is possible that these two components weakly interact in the solid phase.

Reaction with potassium thiocyanate gave an orange solid, insoluble in organic solvents so that separation from the by-product, potassium chloride, was impossible. The analogous reaction with phosphonitrilic chloride leads to the formation of the isothiocyanate derivative<sup>442</sup> and a similar result might be expected in this case. The infrared spectrum of the crude product bore no resemblance to that of sulphanuric chloride and did not show an absorption at  $\sim 2000 \text{ cm}^{-1}$  which is characteristic<sup>443</sup> of the -NCS group. The orange-red pyridine-2-isothiocyanate which exists as a dimer does not show this absorption. It was concluded that the product was a polymeric isothiocyanate.

N,N diethylaminotrimethylsilane is a useful reagent for the introduction of  $-\text{NEt}_2$  groups. Thus, Abel and Armitage<sup>444</sup> have reported the reactions,

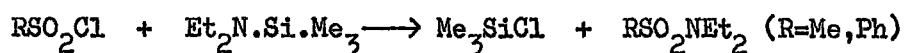

Reaction with  $\alpha$ -sulphanuric chloride gave an oil, the analyses for which approximate to those required for the diethylamino derivative,  $(\text{NSOEt}_2)_3$ . The crude product is expected to be a mixture of at least two isomers but attempts to separate these by sublimation or recrystallisation were unsuccessful.

The infrared spectrum of the oil is very similar to those reported<sup>125,127</sup> for other sulphanuric derivatives.

It seems that, in general,  $\alpha$ -sulphanuric chloride undergoes ring cleavage rather than simple metathesis reactions. Low temperature reactions with nucleophiles of low basicity, e.g., morpholine<sup>127</sup> and N,N diethylaminotrimethylsilane do, however, result in substitution. During the course of this work Moeller and Ouchi<sup>125</sup> have reported the synthesis of some derivatives of sulphanuric fluoride which undergoes metathesis reactions more readily than the chloride. These authors have suggested that the lack of substitution of  $\alpha$ -sulphanuric chloride by more basic reagents may be a consequence of the exothermic vigour with which the chlorine atoms are solvolytically removed. The mass spectrum of  $\alpha$ -(NSOCl)<sub>3</sub>, Table 21 and Fig.20, is of interest in this context. Few of the species formed are sufficiently stable to give rise to measurable peaks and the suggested breakdown pattern is somewhat tentative. The most abundant peaks are those due to  $(N_3S_3O_3Cl_2)^+$ , which is formed by loss of one chlorine atom. It seems <sup>that</sup> further ionisation processes lead to the formation of very unstable species and that the sulphur-nitrogen ring is readily cleaved. Possibly the formation of cyclic cations involves profound changes in the ring geometry with consequent breakdown in the delocalised  $p\pi - d\pi$  system. Similar factors may operate in methathesis reactions if these proceed via solvolytic removal of the chlorine atoms.

Fig.20

The mass spectroscopic breakdown of  $\alpha$ -(NSOCl)<sub>3</sub>. Routes involving species not observed in the spectrophotometer are shown .....

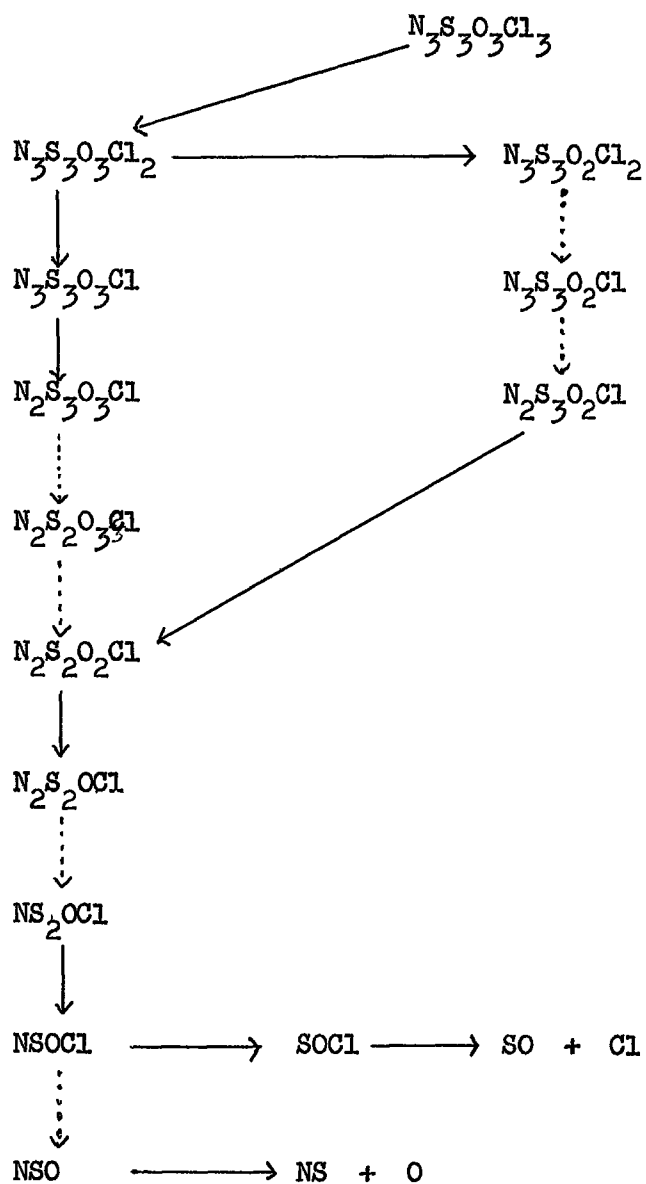

Table 21

The mass spectrum of  $\alpha$ -(NSOCl)<sub>3</sub>. Accelerating potential 70 ev.,  
Source temperature 90°C

Nominal mass	rel. int.	species
291	4.8	N <sub>3</sub> S <sub>3</sub> O <sub>3</sub> Cl <sub>3</sub>
293	5.3	
295	2.4	
256	100.0	N <sub>3</sub> S <sub>3</sub> O <sub>3</sub> Cl <sub>2</sub>
258	81.6	
260	24.1	
240-244	<2.0	N <sub>3</sub> S <sub>3</sub> O <sub>2</sub> Cl <sub>2</sub>
221	<1.0	N <sub>3</sub> S <sub>3</sub> O <sub>3</sub> Cl
207-209	<1.0	N <sub>2</sub> S <sub>3</sub> O <sub>3</sub> Cl
143	<1.0	N <sub>2</sub> S <sub>2</sub> OCl
99	<1.0	NSOCl
97	2.4	
85	2.5	SOCl
83	7.5	
48	21.6	SO
46	37.4	SN

The infrared spectrum of  $\alpha$ -(NSOCl)<sub>3</sub> is given in Table 22.

Table 22

$\nu$ cm <sup>-1</sup>	assignment
1812w	1100+713 = 1813
1335s	$\nu$ S-O
1326s	2 x 663 = 1326
~1100s (broad)	
812m	
713ms	
702ms	
669sh	$\nu$ S-Cl
663s $\nu$ 540ms	

Using the measured S-O bond length (1.407 $\text{\AA}$ ), and the relationship between S-O bond lengths and stretching frequencies derived in the spectroscopic section, the predicted value of  $\nu_{\text{S-O}}$  in  $\alpha\text{-(NSOCl)}_3$  is 1334  $\text{cm}^{-1}$ . The observed band at 1335  $\text{cm}^{-1}$  overlaps with one at 1326  $\text{cm}^{-1}$  which appears to be an overtone of the band at 663  $\text{cm}^{-1}$ . The band at 540  $\text{cm}^{-1}$  is in the region expected for the S-Cl stretching vibration.<sup>340</sup> From the relationship between S-N bond lengths and stretching frequencies (spectroscopic section)  $\nu_{\text{S-N}}$  is predicted at 1025  $\text{cm}^{-1}$ . No band is observed at this frequency. It seems that exocyclic groups give rise to stretching frequencies in the expected regions and that other bands (1100-660  $\text{cm}^{-1}$ ) are to be associated with ring stretching and deformation modes.

References

1. E.C.Franklin, The Nitrogen System of Compounds, Reinhold Publishing Corporation, N.Y. 1935.
2. L.F.Audrieth, M.Sveda, H.H.Sisler and M.J.Butler, Chem. Rev., 1940, 26, 49.
3. E. Berglund, Bull. Soc. chim. France, 1878, 29, 422.
4. F. Raschig, Ann., 1887, 241, 161
5. M.E.Cupery, Ind. Eng. Chem., 1938, 30, 627.
6. M.J.Butler and L.F.Audrieth, J.Amer.Chem.Soc., 1939, 61, 914.
7. M.Becke-Goehring, Advances in Inorganic and Radiochemistry, vol.II. p.159, Academic Press, N.Y. 1960.
8. K.Osaki, H.Tadokoro and I.Nitta, Bull.Chem.Soc. Japan, 1955, 28, 524.
9. R.L.Sass, Acta Cryst., 1960, 13, 320.
10. G.A.Jeffrey and H.P.Stadler, J.Chem.Soc., 1957, 1467.
11. Inorganic Synthesis, Vol.II, pp.176, 177, McGraw Hill, N.Y. 1946.
12. F.Ephraim and M.Gurewitsch, Ber., 1910, 43, 138.
13. A.V.Kirsanov, J.Gen.Chem. (U.S.S.R.), 1952, 22, 101.
14. A. Meuwsen, Colloq. Intern. Union Pure Appl.Chem., Munster, 1954, p.130.
15. R. Appel and G. Berger, Chem. Ber., 1958, 91, 1339.
16. R. Graf, Ger. Patent, 937, 645, (1956).
17. R. Graf, Chem. Ber., 1956, 89, 1071.
18. R. Graf, Ger. Patent, 944, 009, (1956).
19. R. Appel and W. Senkpiel, Angew. Chem., 1958, 70, 572.
20. J.Regnault, Ann. Chem. Phys., 1838, 69, 170.
21. W. Traube, Ber., 1892, 25, 2472.

22. W.Traube, *ibid.*, 1893, 26, 607.
23. O.Ruff, *ibid.*, 1903, 36, 2900
24. E.F.Degering and G.C.Cross, *Ind. Eng.Chem.*, 1943, 35, 751.
25. E.F.Degering and G.C.Cross, *U.S.Patent*, 2, 407, 481 (1946).
26. F.C.Wood and A.E. Battye, *Chem. Ind.* 1933, 52, 347.
27. F.Ephraim and F.Michel, *Ber.*, 1909, 42, 3833.
28. G.Broja, *Ger. Patent*, 814, 143 (1951).
29. R.Appel and W.Huber, *Ber.*, 1956, 89, 386.
30. R.Osswald, *U.S.Patent*, 2, 117, 626 (1938)
31. M.Goehring, J.Heinke, M.Malz and G.Roos, *Z. anorg.Chem.*, 1953, 273, 200.
32. A.M.Paquin, *Angew.Chem.*, 1948, 60, 319.
33. H.A.Walter, *U.S.Patent*, 2, 449, 520 (1942).
34. A.Hantzsch and A.Holl, *Ber.*, 1901, 34, 3430.
35. A.Hantzsch and O.Stuer, *ibid.*, 1905, 38, 1022.
36. G.Hienze and A. Meuwsen, *Z. anorg.Chem.*, 1954, 275, 49.
37. M.Becke-Goehring, H.Hohenschutz and J.Ebert, *ibid.*, 1954, 276, 47.
38. Y.Ito, *Kogyo Kagaku Zasshi*, 1960, 63, 1198.
39. K.R.Andress and K.Fischer, *Naturwiss.*, 1953, 40, 240.
40. R.Appel and G.Berger, *Z. anorg.Chem.*, 1964, 327, 114.
41. R.Appel and M.Becke-Goehring, *ibid.*, 1953, 271, 171.
42. R.Appel and W.Huber, *ibid.*, 1954 275, 338.
43. M.Becke-Goehring, *Quart.Rev.*, 1956, 10, 437.
44. O.Glemser, *Angew.Chem. (Internat.Edit.)*, 1963, 2, 530.
45. L.F.Audrieth, *J.Chem.Educ.*, 1957, 34, 545.

46. M.Gregory, J.Pharm., 1835, 21, 315; 22, 301.
47. E.Soubeiran, Ann. Chim. Phys., 1838, 67, 71.
48. J.M.Fordos and A.Gélis, Compt. rend., 1850, 31, 702.
49. A.Andreocci, Z. anorg.Chem., 1896, 14, 246.
50. R.Schenck, Annalen, 1896, 290, 171.
51. D.Clark, J.Chem. Soc., 1952, 1615.
52. O.Ruff and E.Geisel, Ber., 1905, 38, 2659.
53. O.Ruff and E.Geisel, ibid., 1904 37, 1573.
54. A.Michaelis, Z. Chem. 1870, 6, 460.
55. E.Divers and T.Haga, J.Chem.Soc., 1896, 1634.
56. B.Cohen, T.R.Hooper and R.D.Peacock, J.Inorg.Nuclear Chem., 1966, 28, 919.
57. W.Moldenhauer and A.Zimmermann, Ber., 1929, 62, 2390.
58. A.H.Macbeth and H.Graham, Proc.Roy. Irish Acad., 1923, 36, 31
59. H.B. van Valkenburgh and J.C.Bailar, J.Amer.Chem.Soc., 1925, 47, 2134.
60. F.E.Francis and O.C.M.Davis, J.Chem.Soc., 1904, 259.
- ↗ 61. Synthetic Inorganic Chemistry, p.166, Prentice Hall, New Jersey, 1960.
- ↘ 62. Inorganic Synthesis, Vol.VI, p.124, McGraw Hill, N.Y. 1960.
63. M.Becke-Goehring, Chem.Ber., 1947, 80, 110.
64. V.Murphy, Proc. Judien Acad. Sci., 1953, 37A, 23
65. A.Meuwesen, Ber., 1929, 62, 1959.
66. M.Becke-Goehring and J.Ebert, Z. Naturforsch, 1955, 10b, 241.
67. A.Faessler and M.Becke-Goehring, Naturwiss., 1952, 39, 169; 1943, 31, 567.
68. H.Wölbling, Z. anorg.Chem., 1908, 57, 281.



69. E.Fluck, Diplomarbeit, Heidelberg, 1956.
70. M.H.M.Arnold, J.Chem.Soc., 1938, 1596.
71. E.R.Lippincott and M.C.Tobin, J.Amer.Chem.Soc., 1951, 73, 4990.
72. Chia-Si Lu and J.Donohue, *ibid.*, 1944, 66, 818.
73. J.Donohue and B.D.Sharma, Acta Cryst., 1963, 16, 891.
74. I.Lindquist, J.Inorg.Nuclear Chem., 1958., 6, 159.
75. D.P.Craig, Chem.Soc.Spec.Publ.No.12; J.Chem.Soc., 1959, 977; D.P.Craig and N.L.Paddock, Nature, 1958, 181, 1052.
76. D.Chapman and A.G.Massey, Trans.Faraday Soc., 1962, 58, 1291.
77. M.J.S.Dewar, E.A.C.Lucken and M.A.Whitehead, J.Chem.Soc., 1960, 2423.
78. P.S.Bateman, *ibid.*, 1965, 2297.
79. A.G.Turner and F.S.Mortimer, Inorg.Chem., 1966, 5, 906.
80. M.Becke-Goehring and D.Voigt, Naturwiss., 1953, 40, 482; Z. anorg.Chem., 1956, 285, 181.
81. W.Gesierich, Diplomarbeit, Heidelberg, 1954.
82. M.Becke-Goehring, J.Weiss and G.Zirker, Z.anorg.chem., 1955, 278, 1.
83. W.Berg, M.Becke-Goehring and M.Malz, *ibid.*, 1956, 283, 13.
84. W.Berg and M.Becke-Goehring, *ibid.*, 1954, 275, 273.
85. J.Weiss and D.Neubauer, Z.Naturforsch., 1958, 13b, 459.
86. M.Becke-Goehring and G.Zirker, Z.anorg.Chem., 1956, 285, 70.
87. A.Meuwesen and M.Lösel, *ibid.*, 1953, 271, 221.
88. M.Becke-Goehring, K.W.Daum and J.Weiss, Z.Naturforsch., 1955, 10b, 298.
89. E.Fluck, M.Becke-Goehring and J.Weiss, Z.anorg.chem., 1956, 287, 51.
90. T.S.Piper, Chem. Ind., 1957, 37, 1101.

91. J.Weiss and M.Becke-Goehring, Z.Naturforsch., 1958, 13b, 198.
92. M.Becke-Goehring and A.Debo, Z.anorg.Chem., 1953, 273, 319.
93. K-W.Daum, M.Becke-Goehring and J.Weiss, ibid., 1958, 278, 260.
94. M.Becke-Goehring and K-W.Daum, ibid., 1955, 282, 83.
95. J.Lindquist and J.Weiss, J.Inorg.Nuclear Chem., 1958, 6, 184.
96. J.Weiss, Fortschr. chem. Forsch., 1966, 5, 635.
97. M.Becke-Goehring, M.Hohenschutz and R.Appel, Z.Naturforsch., 1954, 9b, 678.
98. O.C.M.Davis, J.Chem.Soc., 1906, 1575.
99. B.Cohen, T.R.Hopper, D.Hugell and R.D.Peacock, Nature, 1965, 207, 748.
100. K.J.Wynne and W.L.Jolly, Inorg.Chem., 1967, 6, 107.
101. E.Fluck and M.Becke-Goehring, Z.Naturforsch., 1956, 11b, 756.
102. J.S.Padley, Ph.D. Thesis, Durham, 1967.
103. O.Glemser, H.Schroeder and H.Haeseler, Naturwiss., 1955, 42, 44;  
Z. anorg.Chem., 1955, 279, 28.
104. H.Richert and O.Glemser, Z. anorg.Chem., 1961, 307, 328.
105. G.A.Wiegers and A.Vos, Acta Cryst., 1961, 14, 562; 1963, 16, 152.
106. O.Glemser and H.Lüdemann, Angew.Chem., 1958, 70, 190.
107. O.Glemser and H.Perl, unpublished results, quoted in ref.44.
108. H.Scroder and O.Glemser, Z. anorg.Chem., 1959, 298, 78.
109. D.A.Skoog and J.K.Barlett, Analyt.Chem., 1955, 27, 369.
110. E.Fluck, M.Becke-Goehring and R.Dehoust, Z. anorg.Chem., 1961, 312, 60.
111. A.Meuwesen, Ber., 1931, 64, 2311.
112. G.A.Wiegers and A.Vos, Proc.Chem.Soc., 1962, 387; Acta Cryst., 1966, 20, 192.

113. A.Meuwesen, Colloquium of the Inorg.Chem.Section, Int. Union Pure Appl.Chem., Munster (Westphalia), Sept.2-6, 1954. p.130.
114. M.Becke-Goehring and H.Malz, Z.Naturforsch., 1954, 9b, 567.
115. A.Meuwesen and S.Kruger, Z.anorg.Chem., 1938, 236, 221.
116. G.Weis, Diplomarbeit, Heidelberg, 1955.
117. A.G.MacDiarmid, Nature, 1949, 164, 1131.
118. A.V.Kirsanov, J.Gen.Chem. (U.S.S.R.), 1953, 22, 93.
119. M.Becke-Goehring, J.Heinke, H.Malz and G.Roos, Z. anorg. Chem., 1953, 273, 200.
120. A.Vandù, T.Meoller and T.L.Brown, Inorg.Chem., 1963, 2, 899.
121. J.C. van de Grampel and A.Vos, Rec.Trav.chim., 1962, 82, 246.
122. A.J.Banister, private communication.
123. H.Malz, Dissertation, Heidelberg, 1954.
124. F.Seel and G.Simon, Z. Naturforsch, 1964, 19b, 354.
125. T.Meoller and A.Ouchi, J.Inorg.Nuclear Chem., 1966, 28, 2147.
126. M.Becke-Goehring, Developments in Inorganic Polymer Chemistry, Eds., M.F.Lappert and G.J.Leigh, Elsevier, N.Y. 1962.
127. A.Failli, M.A.Kresge, C.W.Allen and T.Meoller, J.Inorg.Nuclear Chem., 1962, 2, 165.
128. A.J.Banister and A.C.Hazell, Proc.Chem.Soc., 1962, 282.
129. G.A.Weigers and A.Vos, *ibid*, 1962, 387.
130. A.C.Hazell, G.A.Weigers and A.Vos, Acta Cryst., 1966, 20, 186.
131. G.A.Weigers and A.Vos, *ibid.*, 1963, 16, A.40.
132. A.Wilson and D.F.Carroll, J.Chem.Soc., 1960, 2548.
133. N.L.Paddock, Quart.Rev., 1964, 18, 168.

134. M.T.Rogers and K.J.Gross, J.Amer.Chem.Soc., 1952, 74, 5294.
135. E.Demarcay, Compt. rend., 1880, 91, 1066.
136. W.Muthmann and E.Seitter, Ber., 1897, 30, 627.
137. M.Becke-Goehring, and H.P.Latascha, Z.Naturforsch., 1962, 17b, 125.
138. A.G.MacDiarmid, J.Amer.Chem.Soc., 1957, 78, 3871.
139. A.Meuwson, Ber., 1932, 65, 1724.
140. H.Garcia-Fernandez, Compt. rend, 1960, 250, 3181
141. A.Meuwesen and O.Jacob, Z.anorg.Chem., 1950, 263, 200.
142. M.Becke-Goehring and D.Voigt, *ibid.*, 1956, 285, 181.
143. H.Schröder and O.Glemser, *ibid.*, 1959, 298, 78.
144. M.Becke-Goehring, Progress in Inorganic Chemistry, 1959, 1, 207.
145. M.Becke-Goehring and H.P.Latascha, Z.anorg.Chem., 1964, 333, 181.
146. O.Glemser, A.Haas and H.Reinke, Z.Naturforsch. 1965, 20b, 809.
147. M.Becke-Goehring, *ibid*, 1954, 9b, 678.
148. M.Becke-Goehring and G.Magin, *ibid.*, 1965, 20b, 493.
149. M.Becke-Goehring, Z. anorg.Chem., 1953, 271, 281.
150. O.Glemser and E.Wyszomirski, Chem.Ber., 1961, 94, 1443.
151. A.W.Cordes and R.F.Kruh and E.K.Gordon, Inorg.Chem., 1965, 4, 681.
- 152(a) D.A.Johnson, G.D.Blyholder and A.W.Cordes, *ibid.*, 1965, 4, 1790.  
(b) R.T.Bailey and E.R.Lippincott, Spectrochim.Acta, 1964, 20, 1327.
153. O.Glemser, H.Meyer and A.Haas, Chem, Ber., 1964, 97, 1704.
154. O.Glemser, Z. anorg.chem., 1961, 307, 313.
155. B.Cohen, T.R.Hooper and R.D.Peacock, J.Inorg.Nuclear Chem., 1966, 28, 919.

156. W.H.Kirchoff, Ph.D. Thesis, Harvard Univ. Cambridge, Mass., 1962.
157. F.Rogowski, Z. Physik.Chem., 1961, 27, 277.
158. O.Glemser, H.Richert and F.Rogowski, Naturwiss, 1960, 47, 94.
159. H.Siebert, Z. anorg.Chem., 1953, 273, 170.
160. P.W.Schenk, Ber., 1942, 75, 94.
161. O.Glemser, H.Richert and H.Haeseler, Angew.Chem., 1959, 71, 524.
161. O.Glemser and H.Richert, Z. anorg.chem., 1961, 307, 313.
163. O.Glemser and H.Perl, Naturwiss, 1961, 48, 620.
164. K.D.Maguire, J.J.Smith and W.L.Jolly, Chem.Ind., 1963, 39, 1589.
165. W.L.Jolly, K.D.Maguire and D.Rabinovitch, Inorg.Chem, 1963, 2, 1304.
166. A.Clever and W.Muthmann, Ber., 1896, 29, 340.
167. R.F.Kruh, A.W.Cordes, R.M.Lawrence and R.G.Goforth, Acta. Cryst., 1961, 14, 1306.
168. B.Cohen and A.G.MacDiarmid, Chem.Ind., 1962, 1866, 66.
169. F.Seel and O.Detmer, Z. anorg.Chem., 1959, 301, 113.
170. K.Ramaswamy, K.Sathianandan and F.F.Cleveland, J.Mol. Spectroscopy, 1962, 9, 107.
171. O.Glemser and E.Wyszomirski, Angew Chem., 1957, 69, 534.
172. E.Demarcay, Compt. rend., 1881, 92, 726.
173. A.Zalkin, T.E.Hopkins and D.H.Templeton, Inorg.Chem., 1966, 5, 1767.
174. J.R.House, M.Sc. Thesis, Durham, 1966.
175. E.Demarcay, Compt. rend., 1880, 91, 854.
176. S.Ghersetti, Boll. sci. Fac.Chim.Ind.Bologna, 1963, 21, 237.
177. A.E.Robinson, Canad.J.Chem., 1961, 39, 247.
178. L.J.Bellamy and R.L.Williams, J.Chem.Soc., 1957, 863.

179. R.J.Gillespie and A.E.Robinson, *Canad. J.Chem.*, 1963, 41, 2074.
180. R.J.Gillespie and A.E.Robinson, *ibid.*, 1963, 41, 741.
181. F.A.Miller and C.H.Wilkins, *Analyt.Chem.*, 1952, 24, 1253.
182. F.A.Miller, G.L.Carson, F.F.Bentley and W.H.Jones, *Spectrochim. Acta*, 1960, 16, 135.
183. J.K.Ruff, *Inorg.Chem.*, 1965, 4, 567.
184. H.W.Roesky and A.Hoff, *Chem.Ber.*, 1965, 98, 2429.
185. M.Lustig, *Inorg.Chem.* 1965, 4, 104.
186. T.T.Crow and R.T.Lagemann, *Spectrochim.Acta*, 1958, 12, 143.
187. M.J.Frazer, W.Gerrard and F.W.Parrett, *J.Chem.Soc.*, 1965, 342.
188. A.Simon and R.Lehmann, *Z. anorg.Chem.*, 1961, 311, 212.
189. M. Lustig, C.L.Bumgardner, F.A.Johnson and J.K.Ruff, *Inorg. Chem.*, 1964, 3, 116.
190. C.L.Bumgardner and M.Lustig, *ibid.*, 1963, 2, 662.
191. J.K.Ruff, *ibid.*, 1965, 4, 1446.
192. G.Pass, *J.Chem.Soc.*, 1963, 6047.
193. B.Cohen and A.G.MacDiarmid, *Inorg.Chem.* ~~1961, 83, 4521.~~ <sup>1962, 1, 754.</sup>
194. J.M.Shreeve and G.H.Cady, *J.Amer.Chem.Soc.*, 1961, 83, 4521.
195. M.Lustig and G.H.Cady, *Inorg.Chem.*, 1963, 2, 388.
196. H.J.Emeléus and K.J.Packer, *J.Chem.Soc.*, 1962, 771.
197. F.B.Dudley and G.H.Cady, *J.Amer.Chem.Soc.*, 1957, 79, 513.
198. F.B.Dudley, G.H.Cady, <sup>and D.F.Eggers</sup> *Inorg.Chem.*, 1963, 2, 496.
199. W.P.Gilbreath and P.H.Gady, *Inorg.Chem.*, 1963, 2, 496.
200. A.Vandi, T.Moeller and L.F.Audrieth, *J.Org.Chem.*, 1961, 26, 1136.

201. D.D. Des Marteau and G.H.Cady, *Inorg.Chem.*, 1966 5, 169.
202. D.D. des Marteau and G.H.Cady, *ibid.*, 1966, 5, 1829.
203. M.Lustig, *ibid.*, 1965, 4, 1828
204. W.B.Fox and G.Franz, *ibid*, 1966, 5, 946.
205. A.A.Vlečk and F.Basolo, *ibid.*, 1966, 5, 156.
206. L.H.Vogt, J.L.Katz and S.E.Wiberley, *ibid.*, 1965, 4, 1157.
207. W.E.Dasent and D.Morrison, *J.Inorg.Nuclear Chem.*, 1964, 26, 1122.
208. R.Paetzold and K.Aurich, *Z. anorg.Chem.*, 1965, 335, 281.
209. G.Herzberg, *Molecular Spectra and Molecular Structure*, Vol.II, Van Nostrand, New York, 1963, p.167.
210. U.Agawala, C.E.Rees and M.G Thode, *Canad.J.Chem.*, 1965, 43, 2802.
211. W.G.Palmer, *J.Chem.Soc.*, 1961, 1552.
212. A.Simon and H.Wagner, *Z. anorg.Chem.*, 1961, 311, 102.
213. A.Simon, H.Kriegsmann and H.Dutz, *Chem.Ber.*, 1956, 89, 2390.
214. H.G.Houlton and H.V.Tartar, *J.Amer.Chem.Soc.*, 1938, 60, 544
215. D.M.Anderson and N.B.Woodall, *Analyst.Chem.*, 1953, 25, 1906.
216. Yu. Ya.Kharitonov, *Zhur. neorg.Khim.*, 1961 6, 2601.
217. G.Newmann and D.B.Powell, *Spectrochim.Acta*, 1963, 19, 213.
218. J.C.Evans and H.J.Bernstein, *Canad.J.Chem.*, 1955, 33, 1270.
219. H.Seibert, *Z. anorg.Chem.*, 1954, 275, 225.
220. C.Rocchiccioli, *Compt. rend.*, 1957, 244, 2704.
221. R.S.Krishnan, *Proc.Indian Acad.Sci.*, 1946, 23A, 288.
222. R.E.Hester, R.A.Plane and G.E.Walrafen, *J.Chem.Phys.*, 1963, 38, 249.

223. J.C.Decius, Spectrochim. Acta, 1965, 21, 15.
224. J.C.Decius, E.M.Coker and G.L.Brenna, *ibid.*, 1963, 19, 1281.
225. J.P.Mathieu, L.Couture-Mathieu and H.Poulet, J.Phys.Radium., 1955, 16, 781.
226. M.Maas and G.B.B.M.Sutherland, Proc.Roy.Soc., 1956, A236, 427.
227. J.E.Guerchais, A.Haumesser and R.Rohmer, Compt.rend., 1965, 260, 5571.
228. E.Steger and W.Schmidt, Ber. Bunsenges Physik.Chem., 1964, 68, 102.
229. T.Dupuis, Congre. groupe. advance. methodes anal. spectrog. prod. met., 1957, 10e, 109.
230. V.Ananthanarayanan, Indian J.Pure Appl.Phys., 1963, 1, 58.
231. G.E.Walrafen. J.Chem.Phys., 1965, 43, 479.
232. P.Tarte and G.Nizet, Spectrochim. Acta, 1964, 20, 503.
233. S.D.Ross, *ibid.*, 1962, 18, 1575.
- 234(a) C.Rocchiccioli, Compt. rend., 1963, 257, 3851;  
(b) Microchim. Ichnoanal. Acta, 1964, 5, 764.
235. A.V.Korshunov, A.A.Kolovskii and R.I.Podgaetskaya, Optika i Spektroskopiya, 1963, 2, 299.
236. K.Takemoto and Y.Saiki, Sekko to Sekkai, 1962 No.61, 277.
237. M.Harmelin, Ann.Chim., (France), 1963, 8, 285.
238. H.R.Oswald, Helv.Chim. Acta, 1965, 48, 600.
239. J.S.Cho, F.A.Olson and M.E.Wadsworth, Trans.A.I.M.E., 1964, 230, 1419.
240. H.Tai and A.L.Underwood, Analyt.Chem., 1957, 29, 1430.
241. A.I.Stekhanov and Z.A.Gabrichidze, Fiz. Tverd. Tela., 1963, 5, 3109.
242. I.Levestek, Proc.Intern.Meeting Mol.Spectry. 4th.Bologna, 1959 3, 123.



243. E.Petreanu, S.Pinchas and D.Samuel, J.Chem.Soc., 1963, 2822.
244. R.S.Krishnan and P.Neelakantan, Indian J.Pure Appl.Phys., 1965, 3, 4.
245. J.M.Hunt, M.P.Wisherd and L.C.Bonham, Analyt.Chem., 1950, 22, 1478.
246. R.I.Razouk, A.Sh.Salem and R.Sh.Mikhail, J.Phys.Chem., 1960, 64, 1350.
247. G.A.Zaitsev and B.S.Neporent, Zhur. eksp.teor.Fiz., 1955, 29, 857.
248. H.Tabe, J.Pharm.Soc. Japan, 1965, 75, 1304.
249. S.D.Chatterjee, N.N.Ghosh and A.M.Naha, J.Phys.Chem., 1952, 20, 344
250. W.L.Jolly, U.S.Atomic Energy Comm., Nat.Sci.Foundation, Wash. D.C., UCRL-2008, 1952, 3.
251. C.Duval and J.Lecomte, J.Chim.phys., 1953, 50, C64.
252. G.V.Jere and C.C.Patel, Canad. J.Chem., 1962, 40, 1576.
253. W.R.McWhinnie, J.Inorg.Nuclear Chem., 1964, 26, 21.
254. G.Pannetier, J.M.Bregeault, C.Ledouturuer and G.Djega-Marissadassoues, Bull.Soc. Chim. France, 1964, 3141.
255. V.V.Pechkovskii and M.A.Gaisinovich, Zhur.neorg.Khim., 1964, 9, 2299.
256. V.Ananthanarayanan, Z.Physik., 1962, 166, 318.
257. W.E.Dasent and T.C.Waddington, J.Chem.Soc., 1960, 3350.
258. G.E.Walrafen and D.M.Dodd, Trans.Faraday Soc., 1961, 57, 1286.
259. R.Savoie and A.Giguere, J.Chem.Phys., 1964, 41, 2698.
260. S.K.Hall and E.A.Robinson, Canad.J.Chem. 1964, 42, 1113.
261. J.Chedin, Ann. Chim. (France), 1937, 8, 243.
262. P.A.Giguere and R.Savoie, J.Amer.Chem.Soc., 1963, 85, 287.
263. P.A.Giguere and R.Savoie, Canad. J.Chem., 1960, 38, 2467.
264. R.J.Gillespie and E.A.Robinson, ibid, 1962, 40, 658.

265. R.J.Gillespie and E.A.Robinson, *ibid.*, 1962, 40, 644.
266. R.E.Hester and R.A.Plane, *Inorg.Chem.*, 1964, 3, 769.
267. P.J.Antikainen, *Suomen Kem.*, 1958, 31B, 223.
268. C.Duval and J.Lecomte, *Compt. rend.*, 1954, 239, 249.
269. K.Omori and P.F.Kerr, *Sci. Reports Tohoku Univ., Third Ser.*, 1964, 9, 1.
270. G.Pannetier and J.M.Bregeault, *Bull.Soc. chim. France*, 1965, 609.
271. S.Jaulmes, *Rev. Chim. Minerale*, 1965, 2, 147.
272. W.D.Keller, J.H.Spotts and D.L.Biggs, *Amer.J.Sci.*, 1952, 250, 453.
273. K.Buijs, *J.Inorg.Nuclear Chem.*, 1962, 24, 229.
274. A.Simon and H.Kucher, *Z. anorg.Chem.*, 1949, 260, 161.
275. A.Simon and K.Waldmann and E.Steger. *ibid.*, 1956, 288, 131.
276. K.Buijs, *J.Chem. Phys.*, 1962, 36, 861.
277. C.Duval and J.Lecomte, *Bull. Soc. chim.France*, 1944, 11, 376.
278. T.Dupuis and M.Viltange, *Mikrochim. Ichnoanal Acta*, 1963, 753.
279. R.J.Gillespie and E.A.Robinson, *Spectrochim. Acta*, 1963, 19, 741.
280. A.Simon and H.Richter, *Z. anorg. chem.*, 1962, 315, 196.
281. M.Schmidt and T. Sand, *ibid.*, 1964, 330, 179.
282. M.Schmidt and T. Sand, *J.Inorg.Nuclear Chem.*, 1964, 26, 1179.
283. M.E.Baldwin, *J.Chem.Soc.*, 1961, 3123.
284. A.V.Babaeva, Yu.Ya.Kharitonov and Z.M.Novozhenyuk, *Zhur. neorg. Khim.*, 1961, 6, 2281;
- A.B.Babaeva, Yu.Ya.Kharitonov and I.B.Baranovskii, *ibid.*, 1962, 7, 1247;
- A.B.Babaeva, Yu Ya Kharitonov and E.V.Shenderetskaya, *ibid*, 1530.

285. A.V.Babaeva and Yu Ya Kharitonov, Doklady Akad. Nauk, S.S.S.R., 1962, 144, 559.
286. G.A.Earwicker, J.Chem. Soc., 1960, 2620.
287. K.Nakamoto, J.Fujita, S.Tanaka and M.Kobayashi, J.Amer.Chem. Soc., 1957, 79, 4094.
288. H.Siebert, Z. anorg. Chem., 1959, 298, 51.
289. C.G.Barraclough and M.L.Tobe, J.Chem.Soc., 1961, 1993.
290. R.Eskenazi, J.Raskovan and R.Levitus, J.Inorg.Nuclear Chem., 1966, 28, 521.
291. K.W.Nagnall, D. Brown and P.J.Jones, *ibid.*, 1965, 176.
292. M.E.Baldwin, Spectrochim. Acta. 1963, 19, 315.
293. S.E.Livingstone, Quart. Rev., 1965, 19, 386.
294. D. Barnard, J.M.Fabian and H.P.Koch, J.Chem.Soc., 1949, 2442.
295. F.A.Cotton, R. Francis and W.D.Horrocks, J.Phys. Chem., 1960 64, 1534.
296. M.Tamres and S.Searles, J.Amer.Chem. Soc., 1959, 81, 2100.
297. T.Cairns, G.Eglinton and D.T.Gibson<sup>son</sup>, Spectrochim. Acta, 1964, 20, 31.
298. C.C.Price and R.G.Gillis. J.Amer.Chem.Soc., 1953, 75, 4750.
299. W.D.Horrocks and F.A.Cotton, Spectrochim. Acta, 1961, 17, 134.
300. R.S.Drago and D.W.Meek, J.Phys.Chem., 1961, 65, 1466.
301. M.F.Lappert and J.K.Smith, J.Chem.Soc., 1961, 3224.
302. D.G.Holah and J.P.Fackler, Inorg.Chem., 1965, 4, 1721.
303. G.Kaufmann, and M.J.F.Leroy, Bull.Soc.Chim.France, 1966, 3770.
304. D.W.Meek, W.E.Hatfield, R.S.Drago and T.S.Piper, Inorg.Chem., 1964, 3, 1637.
305. J.Selbin, W.E.Bull and L.H.Holmes, J.Inorg.Nuclear Chem., 1961, 16, 219.

306. B.F.G.Johnson and R.A.Walton, *Spectrochim. Acta*, 1966, 22, 1853.
307. W.Strohmeier and J.F.Guttenberger, *Chem.Ber*, 1964, 97, 1871.
308. D.W.Meek, D.K.Straub and R.S.Drago, *J.Amer.Chem.Soc.*, 1960, 82, 6013.
309. E.Augdahl and P.Kaebøe, *Acta. Chem. Scand.*, 1964, 18, 18.
310. R.J.Gillespie and E.A.Robinson, *Canad. J.Chem.*, 1963, 41, 2074.
311. W.J.Lehmann *J.Mol.Spectroscopy*, 1961, 7, 261.
312. P.W.Schenk and R.Steudel, *Angew.Chem. (Internat.Edit.)*, 1965, 4, 402.
313. V.Wannagat and R.Pfeiffenschneider, *Z. anorg.Chem.*, 1958, 297, 151.
314. D.A.Long and R.T.Bailey, *Trans.Faraday Soc.*, 1963, 59, 792.
315. I.W.Herrick and E.L.Wagner, *Spectrochim.Acta.*, 1965, 21, 1569.
316. D.J.Meschi and R.J.Myers, *J.Mol.Spectroscopy*, 1959, 3, 405.
317. F.A.Kanda and A.J.King, *J.Amer.Chem.Soc.*, 1951, 73, 2315.
318. K.Osaki, H.Tadokoro and I.Nitta, *Bull.Chem.Soc.Japan*, 1955, 28, 524.
319. P.G.Taylor and C.A.Beevers, *Acta.Cryst.*, 1952, 5, 341.
320. D.P.Stevenson and R.A.Cooley, *J.Amer.Chem.Soc.*, 1940, 62, 2477.
321. K.N.Trueblood and S.W.Mayer, *Acta Cryst.*, 1956, 2, 628.
322. D.W.J.Cruickshank, *J.Chem.Soc.*, 1961, 5486.
323. I.Lindquist, *Inorganic Adduct Molecules of oxo-compounds*, Academic Press, New York, 1963.
324. W.M.Zachariassen and H.E.Buckley, *Phys.Rev.*, 1931, 37, 1295.
325. D.Grand-Jean, R.Weiss and R.Kern, *Compt. rend.*, 1962, 255, 964.
326. P.Kierkegaard and B.Nyberg, *Acta.Chem.Scand.*, 1965, 19, 2189.
327. K.B.Harvey, F.R.McCourt and H.F.Shurvell, *Canad.J.Chem.*, 1964, 42, 960.

328. P.A.Giguere and M.Falk, *ibid.*, 1956, 34, 1833.
329. R.Bent and W.R.Ladner, *Spectrochim.Acta*, 1963, 19, 931.
330. R.W.Lovejoy, J.M.Colwell, D.F.Eggers and G.D.Halwey, *J.Chem.Phys.*, 1962, 36, 612.
331. R.W.Lovejoy, J.M.Colwell, D.F.Eggers and G.D.Halsey, U.S. Dept. Comm. Office Tech. Serv. AD 263, 127 (1961).
332. H.Gerding and N.F.Moerman, *Z. phys.Chem.*, 1937, 35B, 216.
333. V.F.Kulik, Yu P.Egorov, M.S.Marenets and L.M.Yagupol' skii, *Zhur.Strukt.Khim.*, 1963, 4, 541.
334. N.S.Ham and A.M.Hambly, *Austral.J.Chem.*, 1953, 6, 33.
335. G.Malewski and H.J.Weigmann, *Spectrochim.Acta.*, 1962, 18, 725.
336. W.R.Fearheller and J.E.Katon, *ibid.*, 1964, 20, 1099.
337. A.Simon and H.Kriegsmann, *Chem. Ber.*, 1956, 89, 1718.
338. A.Simon and H.Kriegsmann, *ibid.*, 2384.
339. A.M. Vuagnat and E.L.Wagner, *J.Chem.Phys.*, 1957, 26, 77.
340. A.J.Banister, L.F.Moore and J.S.Padley, Chapter 5 in *Inorganic Sulphur Chemistry*, Ed.G.Nickless, Elsevier, in press.
341. G.A.Jeffrey and H.P.Stadler, *J.Chem.Soc.*, 1951, 1467.
342. T.Jordan, H.Warren Smith, L.L.Lohr and W.N.Lipscomb, *J.Amer. Soc.*, 1963, 85, 846.
343. K.N.Trueblood and S.W.Mayer, *Acta.Cryst.*, 1956, 2, 628.
344. R.L.Sass and J.Donohue, *ibid.*, 1958, 11, 497.
345. L.Pauling, *The Nature of the Chemical Bond*, Cornell University Press, 1960.
346. V.Schomaker and D.P.Stevenson, *J.Amer.Chem.Soc.*, 1941, 63, 37.
347. R.L.Sass, *Acta.Cryst.*, 1960, 13, 320.

348. I.Nakagawa, S.Mizushima, A.Saraceno, J.J.Lane and J.V.Quagliano, *Spectrochim. Acta*, 1958, 12, 239.
349. R.J.Phillips and H.Moore, *ibid.*, 1961, 17, 1004.
350. E.R.Lippincott and M.C.Tobin, *J.Chem.Phys.* 1953, 21, 1559.
351. E.R.Lippincott and M.C.Tobin, *J.Amer.Chem.Soc.*, 1951, 73, 4990.
352. B.D.Stone and M.L.Nielson, *ibid.*, 1959, 81, 3580.
353. H.Garcia-Fernandez, *Compt. rend.*, 1965, 260, 6107; 1965, 261, 745.
354. R.C.Brasted and J.S.Pond, *Inorg.Chem.*, 1965, 4, 1163.
355. H.Heal and J.Kane, *Nature*, 1964, 203, 971.
356. H.Heal, *ibid.*, 1963, 199, 371.
357. D.P.Craig and T.Thirunamachandran, *J.Chem.Phys.*, 1965, 43, 4183.
358. G.Tosolimi, *Chem.Ber.*, 1961, 94, 2731.
359. R.C.Peterson, U Grzeskowiak and L.H.Jules, *J.Org.Chem.*, 1960, 25, 1595
360. D.Hadzi, *J.Chem.Soc.*, 1957, 847.
361. A.Maschka, *Monatsh.*, 1954, 84, 89.
362. I.W.Herrick and E.L.Wagner, *Spectrochim.Acta.*, 1965, 21, 1569.
363. P.Nannelli, A.Failli and T.Moeller, *Inorg.Chem.*, 1965, 4, 558.
364. T.Uno, K.Machida and J.Hanai, *Spectrochim.Acta*, 1966, 22, 2065.
365. R.Cramer and D.D.Coffman, *J.Org.Chem.*, 1961, 26, 4010.
366. A.Kucsman, F.Ruff and I.Kapovits and J.G.Fisher, *Tetrahedron*, 1966, 22, 1843.
367. O.Glemser, H.Meyer and A.Haas, *Chem.Ber.*, 1965, 98, 2049.
368. A.Muller, O.Glemser and K.Scherf, *ibid.*, 1966, 99, 3568.
369. H.J.Coervan and C.Curran, *J.Amer.Chem.Soc.*, 1958, 80, 3522.
370. T.L.Brown and M.Kubota, *ibid.*, 1961, 83, 4175.

371. A.F.Clifford and L.C.Duncan, *Inorg.Chem.*, 1966, 5, 692.
372. R.D.Dresdner, J.S.Johar, J.Merritt and C.S.Patterson, *ibid.*, 1965, 4, 678.
373. B.Cohen, T.R.Hooper and R.D.Peacock, *Chem.Commun.*, 1966, 1, 32.
374. W.E.Smith, C.W.Tulloch, R.N.Smith and V.A.Engelhardt, *J.Amer., Chem.Soc.*, 1960, 82, 551.
375. A.F.Clifford and C.S.Kobayashi, *Inorg.Chem.*, 1965, 4, 571.
376. W.K.Glass and A.D.E.Pullin. *Trans.Faraday Soc.*, 1961, 57, 546.
377. G.Kresze, A.Maschke, R.Albrecht, K.Bederke, P.Patzchke, H.Smalla and A.Trede, *Angew.Chem (Internat.Edit)*, 1962, 1, 89.
378. W.Wiegrabe, H.Bock and W.Luttke, *Chem.Ber.*, 1966, 99, 3737.
379. D.Chapman, R.J.Warn, A.G.Fitzgerald and A.D.Yoffe, *Trans. Faraday Soc.*, 1964, 60, 294.
380. M.Lustig and J.K.Ruff., *Inorg.Chem.*, 1965, 4, 1444.
381. J.C. van der Grampel and A.Vos, *Rec.Trav.Chim.*, 1965, 84, 599.
382. J.Weiss and H.S.Neubert, *Acta.Cryst.*, 1965, 18, 815.
383. P.B.Zeeman, *Canad.J.Phys.*, 1951, 29, 174.
384. G.Kresze and A.Maschke, *Chem.Ber.*, 1961, 94, 450.
385. E.S.Levchenko, E.S.Kozlov, A.A.Kisilenko and O.V.Kirsanov, *J.Gen.Chem. (U.S.S.R.)*, 1963, 33, 2991.
386. F.Seel and G.Simon, *Angew Chem.*, 1960, 72, 709.
387. G.W.Parshall, R.Cramer and R.E.Foster, *Inorg.Chem.*, 1962, 1, 677.
388. C.A.Anderson and C.E.Miller, *J.Amer.Pharm.Assoc., Sci.Ed.*, 1948, 37, 204.
389. G.Brauer, *Handbook of Preparative Inorganic Chemistry, Vol.1.* Academic Press, London, 1963.
390. W.J.Hickinbottom, *Reactions of Organic Compounds*, Longmans, London, 1936.

391. H. Lecher and F. Holschneider, Ber., 1924, 57, 755.
392. R. O. Sauer and R. H. Hasek, J. Amer. Chem. Soc., 1946, 68, 241.
393. K. A. Jensen, Z. anorg. Chem., 1943, 250, 257.
394. Inorganic Syntheses, Vol. II. p. 173, McGraw Hill, New York, 1946.
395. J. Jackson and G. B. L. Smith, J. Amer. Chem. Soc., 1940, 62, 544.
396. A. V. Kirsanov, J. Gen. Chem. (U.S.S.R.) 1952, 22, 329.
397. V. I. Seychenko, V. T. Stratrenko and A. M. Pinchuk, ibid, 1964, 34, 4014.
398. H. Majda and K. Okon, Biul. Wojskoweg, Akad. Tech., 1961, 10, 101.
399. V. Gutmann, Montan<sup>t</sup>sh., 1954, 85, 1077.
400. D. L. Herring, Chem. Ind., 1960, 717.
401. G. Tesi, C. P. Haber and C. M. Douglas, Proc. Chem. Soc., 1960, 219.
402. W. T. Reichle, Inorg. Chem., 1964, 3, 402.
403. J. E. Leffler and L. J. Todd, Chem. Ind., 1961, 512.
404. O. C. Dermer and M. T. Edmison, J. Amer. Chem. Soc., 1955, 77, 70.
405. J. C. Sheldon and B. C. Smith, Quart. Rev., 1960, 14, 200.
406. A. V. Kirsanov, J. Gen. Chem. (U.S.S.R.) 1950, 20, 303.
407. A. V. Kirsanov, J. Gen. Chem. (U.S.S.R.) 1952, 22, 329.
408. A. V. Kirsanov and N. L. Egorova, J. Gen. Chem. (U.S.S.R.), 1955, 25, 171.
409. A. V. Kirsanov, J. Gen. Chem. (U.S.S.R.), 1962, 22, 1389.
410. L. J. Bellamy, The Infrared Spectra of Complex Molecules, Methuen, London, 1954.



431. Z.Brzozowski, Roczniki Chem., 1964, 38, 1079; 1087; 1095.
432. R.C.Paul and S.L.Chadha, Spectrochim.Acta., 1966, 22, 615.
433. S.K.Das, R.A.Shaw, B.C.Smith and C.P.Thakur, Chem.Comm., 1966, 33.
434. D.Neubauer and J.Weiss, Z. anorg.Chem., 1960, 303, 28.
435. J.Dyson and N.L.Paddock, Chem.Comm., 1966, 191.
436. D.Feakins, W.A.Last and R.A.Shaw, Chem.Ind., 1962, 510.
437. S.K.Ray and R.A.Shaw, *ibid.*, 1961, 1173.
438. T.Moeller and S.G.Kokalis, J.Inorg.Nuclear Chem., 1963, 25, 875.
439. D.Feakins, W.A. Last and R.A.Shaw, J.Chem.Soc., 1964, 4464.
440. D.Feakins, *ibid.*, 1965, 2804.
- 441; C.R.Patrick and G.S.Prosser, Nature, 1960, 187, 1021.
442. G.Tesi, R.J.A.Otto, F.G.Sherif, and L.F.Audrieth, J.Amer. Chem.Soc., 1960, 82, 528.
443. J.C.Howard and J.G.Michels, J.Org.Chem., 1960, 25, 829.
444. E.W.Abel and D.A.Armitage, J.Chem.Soc., 1964, 3122.

773s, 694sh, 687ms, 669w, 631w, ~550wm, ~440m.

Evaporation of orange-red solution to dryness gave a red-brown solid which was recrystallised from toluene-hexane mixture. The infrared spectrum of the recrystallised material was identical with that of an authentic sample of  $\text{Ph}_3\text{SbCl}_2$ .

Chapter 5

**Structural Studies on Sulphur Species**

A J BANISTER, L F MOORE AND J S PADLEY

*Chemistry Department, University of Durham, Durham City (Great Britain)*

CONTENTS

- 1 Infrared and Raman spectroscopy Introduction
- 2 Infrared spectra
  - (a) The origins of infrared spectra
  - (b) Theory
    - (i) Introduction
    - (ii) Absorption frequency as a function of mass and bond strength
    - (iii) Number of vibrations as a function of molecular geometry and symmetry
    - (iv) Overtones and combination bands
    - (v) Characteristic band shapes for gases, liquids and solids
      - (1) Gases
      - (2) Liquids
      - (3) Solids
    - (vi) Fermi resonance
    - (vii) Electronic effects
    - (viii) Molecular strain and steric hindrance
    - (ix) Frequency shifts within one phase
      - (1) Gases
      - (2) Liquids
      - (3) Solids
    - (x) Phase change effects
- 3 Raman spectra
  - (a) Origin of Raman effect
  - (b) Polarisation of Raman lines
- 4 X-ray diffraction
- 5 Hydrogen
  - (a) H<sub>2</sub>S, D<sub>2</sub>S and HDS
  - (b) Polysulphides
  - (c) Thiols
- 6 Boron
- 7 Carbon Thiocyanates
- 8 Silicon, germanium, tin and lead
- 9 Nitrogen
  - (a) Spectral data
  - (b) Structural data
- 10 Phosphorus
- 11 Arsenic and antimony
- 12 Oxygen
  - (a) Sulphuryl (-SO<sub>2</sub>-) compounds
  - (b) Oxo-anions and complexes
    - (i) Sulphates
    - (ii) Thiosulphates

- (iii) Other oxo-anions
  - (iv) Complexes containing oxo-anions as ligands
    - (1) Sulphito compounds
    - (2) Sulphate compounds
  - (c) Thionyl (-SO-) compounds
  - (d) Structural data Bond lengths and bond angles
    - (i) Introduction
    - (ii) Compounds derived from the  $\text{SO}_4^{2-}$  tetrahedra
  - (e) Correlations between stretching frequency and molecular parameters
  - (f) Deformation frequencies
- 13 Sulphur
- 14 Selenium and tellurium
- 15 Halogens
- (a) Sulphur(II) halogen compounds
  - (b) Sulphur(IV) halogen compounds
  - (c) Sulphur(VI) halogen compounds
- 16 Transition metals
- References

## 1. Infrared and Raman spectroscopy: Introduction

With few exceptions infrared and Raman spectra can be obtained for all covalent molecules and all ionic species containing covalently bound atoms. Infrared and Raman spectra provide similar molecular data and either method can supplement or complement the other

Information of three types is obtainable from such spectra

- (i) Most ions and certain functional groups give rise to absorptions at characteristic positions in the infrared and Raman spectra. Consequently the spectra can be used for qualitative diagnosis and in favourable cases can be used for quantitative analysis
- (ii) The shape and symmetry of the system can be derived from the number of observed features arising from fundamental vibrations, and from other details such as vapour phase band envelopes in the infrared, and Raman depolarisation ratios.
- (iii) For a few simple molecules in the gas phase precise values of bond lengths and interbond angles can be calculated. A consideration of such calculations is outside the scope of this Chapter

The main purpose of the following treatment is to summarise the theory, some practical aspects, and literature relevant to the task of identifying (1) inorganic substances containing sulphur and (2) sulphur-containing functional groups and ions

## 2. Infrared spectra

### (a) *The origins of infrared spectra*

As a first approximation, it is possible to consider the non-translational energy of

a molecule as being composed of three additive components due to (1) the energy state of the electrons in the molecule, (2) vibrations of the constituent atoms and (3) the rotation of the molecule as a whole. Absorption of one or more quanta of radiation will increase the appropriate molecular energy level (Fig 5.1). Excitation of the mole-

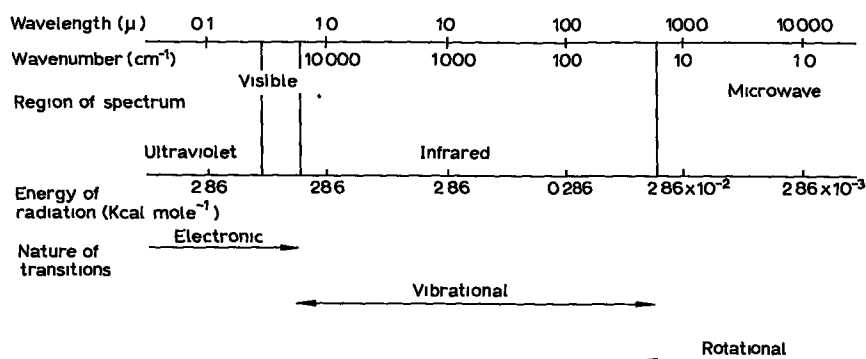

Fig 5.1 The electromagnetic spectrum. Wavelength,  $\lambda$ , is expressed in microns ( $\mu = 10^{-4} \text{cm}^{-1}$ ). The wavenumber,  $\bar{\nu}$ , is  $10^4/\lambda$ .

cule to higher vibrational levels only, generally requires infrared radiation. The energy required to excite pure rotational transitions falls in the far infrared region of the spectrum. However, both vibrational and rotational excitations can occur simultaneously and so each feature in an infrared spectrum is composed of a number of very closely spaced lines present in the vibration-rotation band are often observable (cf section 2.V). Theory shows that when a pure vibrational excitation occurs, the frequency of the infrared radiation absorbed is nearly equal to the mechanical frequency of the vibration. Consequently it can be appreciated using a mechanical molecular model that the frequency of the molecular vibration, and hence of the radiation absorbed, will depend upon the masses of the vibrating atoms and the strengths of the bonds between them. We now consider this approach in more detail to show how the details of an infrared spectrum are dependent upon molecular structure and intermolecular forces.

(b) Theory

(i) Introduction

The position, intensity and contour of an infrared absorption band are determined by molecular parameters and intermolecular forces. The often interdependent factors which determine the overall characteristics of an infrared spectrum can be subdivided and treated separately as follows:

(i) atomic mass,

- (ii) bond strength
  - (iii) molecular geometry and symmetry
  - (iv) overtones and combination bands.
- Variables which can modify one or more of (ii)–(iv) are.
- (v) phase,
  - (vi) Fermi resonance,
  - (vii) electronic effects (inductive, mesomeric and  $\pi$  electron delocalisation)
  - (viii) molecular strain and steric hindrance,
  - (ix) "field" effects which may occur internally within the molecule or as a result of the influence of an external field in a crystal or dielectric
  - (x) solvent effects.

These factors are now discussed

(ii) *Absorption frequency as a function of mass and bond strength*

The complex behaviour of a vibrationally excited molecule can be analysed as the combination of a number of simple oscillations ("fundamental" or "normal" modes of vibration). During a fundamental vibration of a group of atoms, the centre of gravity of the group does not move and all the constituent atoms move with the same frequency and in phase. Adjacent atoms at the extremities of each bond can be taken to be point masses  $M_1$  and  $M_2$  which execute an approximately simple harmonic motion about an equilibrium point. If linkages with the remaining atoms are ignored, the frequency of a fundamental oscillation is given by Hooke's law.

$$\tilde{\nu}(\text{in cm}^{-1}) = \frac{1}{2\pi c} \sqrt{\frac{f}{\mu}} \quad (\text{I})$$

Where  $c$  is the velocity of light,  $f$  is the stretching force constant of the bond (*i.e.* the restoring force per unit displacement from the equilibrium point) and  $\mu$  is the reduced mass of the system. Reduced mass is defined  $1/\mu = 1/M_1 + 1/M_2$  and so

$$\tilde{\nu}(\text{in cm}^{-1}) = \frac{1}{2\pi c} \sqrt{\frac{f(M_1 + M_2)}{M_1 M_2}} \quad (\text{II})$$

An approximate value for the force constant,  $f$ , can often be calculated using Gordy's rule (III)<sup>1</sup> or Badger's rule (IV)<sup>2</sup>. These are purely empirical relations; they occasionally lead to a highly inaccurate value for  $f$

$$f = a N \left[ \frac{x_1 x_2}{r^2} \right]^4 + b \quad (\text{Gordy's rule}) \quad (\text{III})$$

$N$  is the bond order,  $x_1$  and  $x_2$  are the Pauling electronegativity values and  $r$  is the internuclear separation in Ångstrom units. The constants  $a$  and  $b$  are about 1.67 and 0.30 respectively for stable molecules in which the atoms show normal covalencies

$$r = \left( \frac{c}{f} \right)^{1/4} + d \quad (\text{Badger's rule}) \quad (\text{IV})$$

The values of the constants  $c$  and  $d$  depend on the positions of the atoms in the Periodic Table. It is found that the force constant in most (including sulphur) compounds falls within the range  $4-6 \times 10^5$  dynes  $\text{cm}^{-1}$  for single bonds and approximately two or three times this value for double bonds and triple bonds respectively. As indicated by equation (II) above the absorption position becomes  $\sqrt{2}$  and  $\sqrt{3}$  times higher in frequency respectively.

Thus, the equations above show that in principle the approximate frequency of an infrared band can be calculated from mass, bond order and bond length values. Useful values can be obtained even for polyatomic systems where some interference from neighbouring bonds is to be expected. Fig. 5.8 shows how the stretching frequency of sulphur bonds to oxygen, varies with bond length.

Bending force constants are usually about one tenth of the magnitude of stretching force constants and so the bending frequencies of a molecular skeleton of heavy atoms often lie in the far infrared region.

(iii) *Number of vibrations as a function of molecular geometry and symmetry*

For a molecule of  $n$  atoms there are  $3n$  degrees of freedom corresponding to motion of the individual atoms along the three Cartesian axes. Of these degrees of freedom, 3 are translational (motion of the molecule as a whole along the three axes) and 3 rotational (2 for a linear molecule). Thus there are  $3n-6$  ( $3n-5$  for linear molecules) possible modes of vibration and theoretically each of these fundamental modes can absorb energy of a particular frequency. In practice the theoretical number of absorptions is unlikely to be observed because overtones and combination bands (section 2 v) can increase, and other factors can reduce, the number of bands observed. The number of bands can be reduced by theoretical [(i) and (ii)] and by practical [(iii) and (iv)] limitations.

(i) "Forbidden" transitions. If the symmetry of the vibration is such that it results in no (or only slight) change in the dipole moment of the molecule, then absorption will be forbidden in the infrared spectrum (or may be too weak to be detected).

(ii) Degeneracy. Absorptions will occur at identical frequencies if the vibrations responsible for them involve identical *relative* movements of the atoms. In a condensed phase the superimposed absorptions may however be split into a closely spaced multiplet (cf. section 2X).

(iii) Fundamental frequencies may occur outside the range studied.

(iv) Absorption peaks may be too close together to be resolved (accidental degeneracy).

Bond vibration modes are roughly divisible into three distinct types, stretching, bending (or deformation) and torsion. The first consists of periodic stretching of the bond along the bond axis. Bending vibrations are displacements occurring at right angles to the bond axis and consequently involve a change in bond angles. Torsion involves twisting about a bond.

Absorption occurs when the frequency of the oscillating field of the infrared radiation

tion is equal to the frequency of the oscillating dipole produced by the molecular vibration. The magnitude of the molar extinction coefficient is proportional to the square of the change in the dipole moment of the molecule<sup>3</sup>. This results in stretching vibrations often producing the most intense peaks in the spectrum, though certain symmetrical vibrations produce no absorption at all ("infrared inactive", due to no overall change in dipole moment). For instance, the totally symmetric stretching vibrations of  $\text{SO}_3$  and  $\text{SO}_4^{2-}$ , and the totally symmetric stretching (breathing) vibration of  $\text{SF}_6$  do not appear in the infrared spectrum. Unlike tetrahedral  $\text{SO}_4^{2-}$ , the totally symmetric stretching vibration of the trigonal bipyramidal molecule  $\text{SF}_4$  is infrared active. Consequently the number of absorption peaks observed may yield some structural information.

More detailed treatments of vibration spectra can be found in a number of text books<sup>4-11</sup>.

Groups of the type  $\text{AX}_2$  (e.g.  $-\text{CH}_2-$ ,  $-\text{NH}_2$ ,  $-\text{SO}_2-$ ) occur so frequently, particularly in organic compounds, that trivial names have been devised to describe the various possible types of vibration (Fig. 5.2).

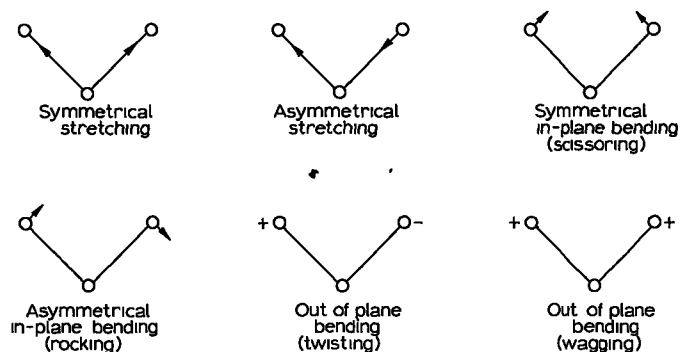

Fig. 5.2 Vibrational modes of the  $\text{AX}_2$  group. + and - represent relative movements perpendicular to the surface of the page.

#### (iv) Overtones and combination bands

These are the two main types of absorption bands which appear in a spectrum additional to the fundamental stretching and deformation modes.

**Overtones** occur at 2, 3 ...  $n$  times the fundamental frequency ( $\frac{1}{2}, \frac{1}{3}, \dots, \frac{1}{n}$  of the wavelength). The first overtone often has  $\frac{1}{10}$ – $\frac{1}{100}$  of the intensity of the fundamental and intensity rapidly diminishes with increasing  $n$ . A first overtone can, however, be unexpectedly weak or unexpectedly strong in an infrared spectrum.

**Combination bands** occur when infrared radiation (of frequency  $\nu_a + \nu_b + \dots$ ) excites two or more fundamentals (of frequencies  $\nu_a, \nu_b$ , etc.) simultaneously. Commonly, except in very weak absorptions, only two fundamentals contribute. Combination bands can be quite strong and numerous and may extend into the near infrared. In sulphur chemistry the population of the near infrared (generally wholly due to over-



tones and combination bands) is appreciably less than for many organic compounds. If, for some reason, some of the lower frequency fundamentals are inaccessible it may be difficult to determine the origin of the overtone and combination bands that they cause.

*Difference bands* (at frequencies equal to e.g.  $\nu_a - \nu_b$ ,  $\nu_a + \nu_b - \nu_c$ ) are also possible but they are normally weak.

(Overtones, combination bands and difference bands are generally very much weaker in Raman spectra than in infrared spectra)

(v) *Characteristic band shapes for gases, liquids and solids*

(1) *Gases*. In the gas phase, molecules are free to rotate and so changes in the rotational energy of the molecule can accompany a vibrational transition. The vibrational band is split into a large number of sharp peaks close together and almost equally spaced on each side of the original vibration frequency. For a diatomic molecule treated as a rigid rotator the frequencies of the sharp peaks are given by the equation.

$$\nu = \nu_0 + \frac{hm}{4\pi^2 I}$$

where  $\nu_0$  is the fundamental vibration frequency in  $\text{sec}^{-1}$ ,  $h$  is Planck's constant,  $I$  is the moment of inertia for the rotation and  $m = 0, \pm 1, \pm 2, \pm 3, \dots$

Rotational fine structure therefore offers a means of calculating moments of inertia and hence bond distances and bond angles. For all molecules the spacing of the lines depends primarily upon the magnitudes of the principal moments of inertia. In small molecules with low moments of inertia, the individual rotational lines will be resolved [e.g., in the water vapour bands at  $5.0\text{--}7.5\mu$  ( $1950\text{--}1350\text{ cm}^{-1}$ )] and accurate molecular parameters can in principle be calculated. In heavier molecules, the individual rotational levels lie too close together to be resolved, the vibration-rotation band then has a smooth contour.

The overall contours of vibration-rotation band systems vary considerably (cf ref 5 p 206) but are composed essentially of three parts, the *P*, *Q* and *R* branches, as required by the above equation. The *Q* branch ( $m = 0$ ) corresponds to a change in vibration quantum number without change in rotational quantum number. The *P* and *R* branches correspond respectively to decrease and increase in the rotational quantum number. The relative intensities of the *P*, *Q* and *R* branches are determined by the symmetry of the vibration and the ratios of the three moments of inertia. In certain cases, the *Q* branch is not observed. Thus, for linear molecules the *Q* branch will be absent if the vibration produces an oscillating molecular dipole parallel to the molecular axis, and asymmetric top molecules (three different principal moments of inertia) give rise to bands with a PR structure only, on account of low intensity of the *Q* branch.

(2) *Liquids*. In the liquid state, the translational kinetic energy of a molecule may be affected as a result of the vibrational excitation; the kinetic energy may contribute to or benefit from the energy involved in the transition. The probability that energy will be transformed in this way falls sharply as the quantity of energy involved in the transfer increases. Consequently intermolecular forces and collisions eliminate not only rotational fine structure (with a few exceptions), but also prevent the occurrence of a sharp line vibrational absorption. The absorption bands of liquids and solutions appear as compressed bellshaped curves of about  $10\text{--}30\text{ cm}^{-1}$  band width at half the peak height.

(3) *Solids*. In the solid state, lattice forces prevent molecular rotation; rotational modes are replaced by the excitation of lattice vibrations (*cf* section 2.1x). Pure solids normally give sharp bands but contour is sensitive to the sampling technique.

(vi) *Fermi resonance*

When two vibrational states of the same symmetry fortuitously give rise to absorptions of close frequency, resonance interaction will occur between them. Both frequency and intensity will be affected and may be to such an extent that the absorptions cannot be assigned to any particular vibration. Perturbation theory shows that the magnitude of the interaction increases with frequency proximity.

In classical terms the interaction can be compared with linked mechanical oscillations in which the molecule gradually transfers its vibration from one mode to the other. A quantum mechanical treatment<sup>6</sup> shows that the coupling pushes the bands further apart (the lower frequency absorption moves down and the higher frequency absorption moves to still higher frequency) and mixes their character (each of the resonating levels takes some of the character of the two contributory vibrations). Also, the weaker absorption "borrows" intensity from the stronger one so that two roughly equally intense bands may be recorded.

The effects of Fermi resonance are most noticeable when an overtone or combination tone has a frequency very close to that of another fundamental. The result is that instead of there being only one strong fundamental absorption band, the normally weak overtone transition acquires some fundamental character and two fairly strong bands are observed.

Despite its restriction to vibrations of similar symmetry the occurrence of Fermi resonance (or "coupling") in infrared (or Raman) spectra is widespread, especially among large molecules.

(vi) *Electronic effects*

Absorption frequencies characteristic of a particular chemical group are often sensitive to electronic effects within the molecule. The relation between frequency and minor changes in constitution has frequently been interpreted in terms of inductive, mesomeric and/or  $\pi$  delocalisation effects. The influence of "field effects"

between non-bonded atoms has not been studied to a great extent in sulphur chemistry but their presence is indicated, for instance, in phase change effects (section 2 x) The importance of electronic interactions is shown by correlations, which have been proposed for organic compounds, between group frequencies and Hammett  $\sigma^{12-18}$  and Taft  $\sigma^*$  factors<sup>19-25</sup>, ionisation potentials<sup>26,27</sup>, electronegativities<sup>28-31</sup>, half wave potentials<sup>32,33</sup> and redox potentials<sup>34,35</sup> References include work on sulphur compounds<sup>12,13,19-21,28</sup>.

Extensive work on organic (and some inorganic) compounds has shown that correlations between frequency shifts and physical properties appear to work best when the comparison involves some experimental measurement of the bond polarity (e.g., change in covalent bond distance, ionisation potential or reactivity) Correlations with more general functions such as electronegativity are less likely to be meaningful Substituent groups show a consistent order of effectiveness provided that the study is limited to groups well removed from the vibrating group The so-called inductive effect of a polar group upon a given linkage can usually be regarded as a composite of true induction effects working along the bonds and non-bonded interactions working across intramolecular space (e.g., electrostatic repulsions between two non-bonded but neighbouring strongly electronegative atoms).

#### (vii) *Molecular strain and steric hindrance*

Work with some cyclic organic compounds<sup>36</sup> has shown that vibration frequencies may be modified by the presence of molecular strain, e.g. the variation of  $\nu(\text{SO})$  with  $n$  in the compounds  $(\text{CH}_2)_n\text{SO}$

Steric hindrances can give rise to electronic interactions between neighbouring but not mutually linked atoms and these interactions may result in appreciable frequency shifts In extreme cases geometrical isomerism becomes possible, each isomer having its own spectrum.

Little similar work has been done on inorganic sulphur compounds but the possible influence of molecular strain and steric hindrance should not be overlooked.

#### (ix) *Frequency shifts within one phase*

(1) *Gases* Since the appearance of resolvable rotational lines depends upon relatively unhindered molecular rotation (cf. section 2 v), it will tend to disappear as pressure or temperature increase<sup>37-39</sup> Chemical interactions typical of the liquid phase can also occur though the effects are less marked

(2) *Liquids* Infrared spectra of pure liquids are affected by interactions such as molecular association and selfionisation<sup>40,41</sup> Additional or modified absorptions may also be caused by solvent impurities particularly water Spectral changes arising in solution have been studied extensively especially for organic systems Almost all the recently reported inorganic and organic studies of solvent effects in infrared

spectra concluded that the predominant interactions were specific solute molecule-solute molecule or solute molecule-solvent molecule interactions rather than effects due to change in dielectric constant or refractive index. The last two factors generally appear to have only a minor effect. The shifts in infrared absorption peaks from one solvent to another ("solvent shifts") have been related to solubility differences<sup>43,44</sup>, and bond moment changes. Solvent shifts,  $\Delta$ , are commonly expressed as fractions of the group frequency

$$\Delta = \frac{\nu(\text{standard solvent}) - \nu(\text{solvent 2})}{\nu(\text{standard solvent})}$$

Structural information can be gained in a number of ways from detailed studies of solution spectra. For instance, molecular association through hydrogen bonding is minimised in dilute solution and no solution studies at several concentrations assist the study of molecular association. Hydrogen bonding (X-H---) greatly increases the integrated intensity of the X-H stretching absorption peak and moves it to lower frequency<sup>36,44-48</sup>. If the hydrogen bonding is strong the band becomes quite broad.

Solution shift data can also be used to check an assignment. If a band in a particular molecule A is suspected as being due to the bond X-Y, solution spectra are measured in a number of different solvents, for this and a similar compound also containing the same group X-Y. A graph is plotted of solvent shift for vibration X-Y, compound A versus shift for vibration X-Y, compound B. A straight line supports the allocation of the band in A to the vibration X-Y.

The most marked solvent shifts encountered when coordination and charge transfer complexes are formed with solvent molecules<sup>49-51</sup>.

(3) *Solids* Solid state spectra are invaluable for qualitative identification but they are less reliable for correlations between absorption frequencies and molecular structure. This is because the electronic environments of the atoms (and hence the number of absorptions, frequencies and band shapes) may be seriously affected by the numerous types of intermolecular forces (particularly crystal forces, dipolar interactions and hydrogen bonding)<sup>44,52-66</sup>. Polymorphic forms of the same substance also give different spectra. As a result of these complications, solid state spectra may be difficult to interpret (also see section 2 x 2).

(x) *Phase change effects*

A Change from the gaseous state to the pure liquid or dissolved state produces in the vibrational spectrum of the solute several characteristic effects

- (i) rotational fine structure disappears or is replaced by a simple band contour
- (ii) liquid bands are usually displaced with respect to the corresponding gas bands, stretching frequencies are often displaced to lower frequencies and bending vibrations sometimes to higher frequencies (These tendencies may be much disturbed by intermolecular interactions)

- (iii) band half widths may be greatly increased,
- (iv) band intensities may change by factors of ten or more,
- (v) there are often more bands in the liquid state than in the gaseous state of a substance.

B. Change in phase from the liquid to the solid state also produces new bands and changes in band frequency and intensity. A major cause of the new bands which frequently appear below about  $150\text{ cm}^{-1}$  ( $66\mu$ ) is lattice vibrations, that is, absorptions due to translational or torsional oscillations of the molecule or ion in the crystal. These new vibrations can form combination bands with existing vibrations with consequential frequency shifts and new absorptions at higher frequencies.

Brief mention has been made (section 3.(iii)) of the part played by molecular symmetry in determining the form of an infrared spectrum. In the solid state there is the additional complication of environmental effects.

(i) Field effects. Shifts of frequency are often found for a given ion in different crystal environments (in which the same environmental symmetry is maintained). For instance, displacements of two of the four fundamental frequencies of the sulphate ion have been related<sup>284</sup> to the ionic radius of the cation.

(ii) Site symmetry. If the crystallographic site symmetry of a molecule or ion differs from the point symmetry of the species, further absorption bands may appear due to (a) splitting of existing degeneracies and (b) relaxation of selection rules<sup>68,69</sup>. The methods for computing these changes have been reviewed in several places<sup>58,9</sup>.

Scattering (see Christiansen effect below) may also modify solid state spectra relative to spectra obtained on liquids. The variations in band position, intensity and contour which occur during change in phase are often unpredictable and may be surprisingly large. This is especially true of band intensity from vapour to liquid states. The less pronounced changes that occur within one phase are better understood. Since intermolecular forces produce spectral complications in both liquids and solids, spectra are best measured in the vapour phase if this is possible, or in solution in a relatively inert solvent.

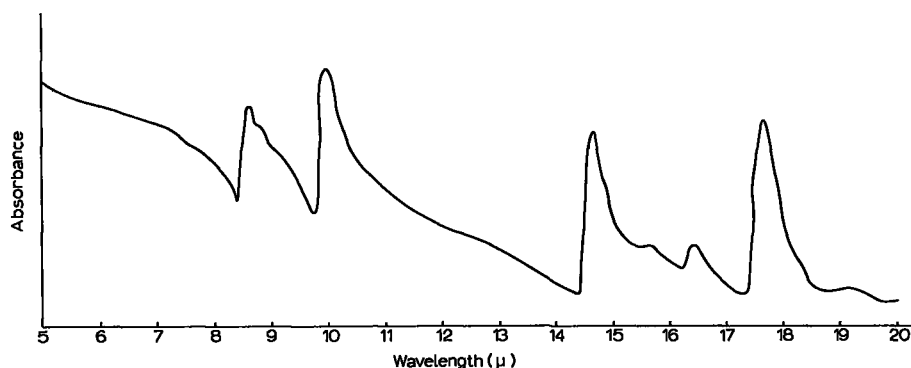

Fig 5.3 Infrared absorption spectrum of the  $S_4N_4$  ion from  $5\mu$  to  $20\mu$ . Band distortion due to Christiansen effect.

*Christiansen Effect*<sup>67</sup>. If the refractive indices of solid particle and surrounding medium differ appreciably, the infrared absorption peaks will be distorted. The effect arises because in the region of an absorption band, the refractive index of a material changes sharply and causes an increase in transmittance on the high frequency side of the band (Fig 5.3)

The effect becomes more serious as particle size approaches the wavelength of the radiation. It is therefore more pronounced at short wavelengths and is minimised by careful grinding. It is never completely eliminated when obtaining spectra of powdered crystalline materials.

### 3. Raman spectra

#### (a) Origin of Raman effect

When a gas or a liquid is illuminated with monochromatic light, the scattered light is mainly of the same frequency (Rayleigh scattering). A very small proportion (usually  $< 1\%$ ) may be of higher or lower frequency. This is the Raman effect. This process differs from that occurring in ultraviolet, infrared and microwave spectroscopy in that the illuminated molecules cause a modification of the energy of the incident photons rather than a complete absorption of a certain proportion of them. It is, therefore, not surprising that the Raman effect depends upon a different molecular property.

Absorption spectroscopy depends upon the interaction of the electric field of the light wave with a change in the electric dipole of the molecule. But the transfer of energy in scattering experiments depends upon the facility with which the radiation can induce a dipole in the molecules that is to say, it depends upon their polarisability. A theoretical treatment shows that the intensity of Rayleigh scattering is proportional to the molecular polarisability but that of the Raman scattering arises from *changes* in the polarisability produced by vibration and/or rotation. Just as infrared absorption frequencies are equal to the frequencies of the oscillating dipoles (*i.e.* the vibration or rotation frequencies), so the Raman frequency shifts are equal to the frequencies at which the polarisability is changing—again the frequencies of vibration and rotation. Hence Raman scattered light has frequencies  $\nu + \nu_R$  where  $\nu$  = incident frequency and  $\nu_R$  = the Raman shift.

As in infrared spectroscopy, Raman frequencies and intensities are governed by molecular and vibrational symmetry. But since the selection rules for the appearance of absorption peaks or Raman lines differ, it frequently happens that fundamental frequencies active in Raman scattering are inactive in the infrared, though lines may appear in both. Raman data may therefore supplement or complement the information obtainable from an infrared spectrum. For instance, weak infrared bands (*e.g.*, from certain symmetrical vibrations involving S-S or S-H) may show clearly in the

Raman spectrum and some medium or strong infrared bands (*e.g.*, overtones and combination bands) may be weak or absent.

Because of the basic similarity between the two techniques, many of the comments made in previous sections, concerning the theory of infrared absorption and the interpretation of spectra, are also applicable to Raman spectra. This similarity between the two techniques forms the background to the following section in which some of the points of difference are briefly considered.

#### (b) *Polarisation of Raman lines*

Further valuable structural information can be obtained from a study of the polarisation of the scattered light.

The light incident on the Raman sample can be regarded as effectively composed of two oscillating electric vectors mutually at right angles and of equal amplitude, likewise, the scattered light may be analysed into two plane-polarised components but the amplitudes (and hence the intensities) are no longer equal. In the Raman experiment, observations are made at right angles to the direction of the incident light; then if  $i$  represents the intensity of the scattered component oscillating *parallel* to this direction and  $I$  the corresponding intensity of the component *perpendicular* to it, the ratio  $i/I$  is called the *depolarisation ratio*,  $\rho$ . The magnitude of  $\rho$  can be determined in practice, at least qualitatively, by using incident light with the plane of polarisation first parallel and then perpendicular to the axis of the sample.

The general rules of polarisation are that *all* vibrational modes that are not totally symmetric will give Raman lines for which  $\rho$  has the maximum value of  $\frac{6}{7}$  (so-called depolarised lines), or else will be inactive. Only totally symmetric vibrations will give rise to polarised Raman lines (*i.e.*  $\rho < \frac{6}{7}$ ). When laser excitation is used,  $\rho$  has the value  $\frac{3}{4}$  for depolarised lines.

Rules particular to molecules with a centre of symmetry (*e.g.*,  $\text{CS}_2$ , *trans*-form of  $\text{XS}_2\text{X}$  molecules) are:

(1) all vibrations which are antisymmetric with respect to the centre of symmetry are forbidden in Raman scattering.

(2) transitions that are allowed in the infrared are forbidden in the Raman spectrum, and *vice versa* (rule of Mutual Exclusion). In certain centro-symmetric molecules, a vibration may appear in neither (*e.g.*, one of the vibrations of  $\text{SF}_6$ <sup>71,72</sup>).

#### 4. X-ray diffraction

The way in which X-ray diffraction can be used for the determination of molecular structure is outlined in many text books, *e.g.*, refs 590–594. The accuracy with which molecular dimensions can be measured is comparable with or better than that attainable by spectroscopic methods. Also X-ray analysis can be applied to a much

wider range of materials including molecules of great complexity. Published data on sulphur bond distances and bond angles are included in the following sub-sections.

The X-ray determination of molecular structure requires the diffraction pattern of a single crystal. If a powder is used the resulting powder diagram is characteristic of the sample and can be used for identification purposes<sup>595-597</sup>.

#### Literature review

Most references were obtained from Chemical Abstracts up to and including December, 1965. Except where stated otherwise, structural information and spectral data are quoted as given by the original authors.

## 5. Hydrogen

### (a) $H_2S, D_2S$ and HDS

All three isotopic species are bent triatomic molecules ( $C_{2v}$  or  $C_s$ ) in the gas phase. The vibrational spectra are summarised in Table 5.1. A number of discrepancies occur

TABLE 5.1  
INFRARED AND RAMAN BANDS OF  $H_2S$ , HDS,  $D_2S$  AND THE POLYSULPHIDES

	$\nu_1(\text{cm}^{-1})$	$\nu_2(\text{cm}^{-1})$	$\nu_3(\text{cm}^{-1})$	References
$H_2S$ gas	2610 8 <sup>a</sup>	1290	2684	78
$H_2S$ liq	2573 6 <sup>a</sup>			78
$H_2S$ solid	2446    2523		2532    2544	84
	2520 8 <sup>a</sup> 2553 7 <sup>a</sup>		2545 8 <sup>a</sup>	84
$D_2S$ gas	1891 6 <sup>a</sup>	934	1999	73
$D_2S$ liq	1866 3 <sup>a</sup>			96
$D_2S$ solid	1835    1753		1843    1854	84
	1832 5 <sup>a</sup> 1853 4 <sup>a</sup>		1848 5 <sup>a</sup>	73
HDS gas		1090	(2684)	
	$\nu(\text{S-H})$			
$H_2S_2$	2509 <sup>a</sup>			85
$H_2S_3$	2513 <sup>a</sup>			87
$H_2S_5$	2513 <sup>a</sup>			88
$H_2S_6$	2513 <sup>a</sup>			88

<sup>a</sup> indicates Raman band

in the reported data for the combination and overtone bands, especially in the earlier reports where it is often not clear as to whether  $\nu_{\text{vac}}$  or  $\nu_{\text{air}}$  has been measured. The frequencies and assignments reported by Bailey, Thompson and Hale<sup>73</sup> appear to be most widely accepted as being correct.

Work on the vibration-rotation bands of  $H_2S$  has been carried out with instruments of low dispersion by Bailey, Thompson and Hale<sup>73</sup> and under higher dispersion by

Nickless      Ch 5 /-/ 1st proof



Nielson<sup>76</sup>, and Cross<sup>75</sup>. Similar studies have been carried out<sup>73,76</sup> on HDS and D<sub>2</sub>S.

Force constants of H<sub>2</sub>S and D<sub>2</sub>S were calculated by Penney and Sutherland<sup>77</sup>, and good agreement was obtained for the two isotopic species. The values of  $4.14 \times 10^5$  and  $4.46 \times 10^5$  dyne cm<sup>-1</sup> for  $k_{HS}$  and  $k_{OS}$  respectively were calculated using the fundamental vibrational frequencies obtained by Bailey *et al.*

The rotational constants and moments of inertia quoted by Crawford<sup>78</sup> have recently been recalculated by Herzberg<sup>79</sup> using the more recent value of the numerical factor  $h/8\pi^2 C$  due to Birge<sup>80</sup>. The results obtained are consistent with the values obtained from microwave spectra<sup>81</sup>, and are listed in Table 5.2

TABLE 5.2

ROTATIONAL CONSTANTS AND MOMENTS OF INERTIA OF H<sub>2</sub>S IN THE LOWEST VIBRATIONAL STATE<sup>68</sup>

$$\begin{aligned} A_0 &= 10\,393 \text{ cm}^{-1}, & I_a^0 &= 2\,694 \times 10^{-40} \text{ g cm}^2 \\ B_0 &= 9\,040 \text{ cm}^{-1}, & I_b^0 &= 3\,097 \times 10^{-40} \text{ g cm}^2 \\ C_0 &= 4\,723 \text{ cm}^{-1}, & I_c^0 &= 5\,927 \times 10^{-40} \text{ g cm}^2 \end{aligned}$$

$$r_0(\text{S-H}) = 1.334 \text{ \AA}$$

$$\widehat{\text{HSH}} = 92^\circ 16'$$

The Raman spectra of liquid H<sub>2</sub>S and D<sub>2</sub>S and D<sub>2</sub>S have been reported<sup>82</sup>, the shifts in Raman frequency accompanying the change from gas to liquid have been determined as 37.2 and 25.3 cm<sup>-1</sup> respectively to lower frequencies<sup>83</sup>.

Three different crystalline phases exist for H<sub>2</sub>S and D<sub>2</sub>S but their structure and the nature of the phase transitions between them are unknown<sup>84</sup>. The lowest temperature phase, III, undergoes transition to phase II at 103.6°K and 107.8°K respectively for H<sub>2</sub>S and D<sub>2</sub>S. The infrared spectra of phase III can be assigned on the basis of an eight-molecule unit cell with symmetry  $D_{4h}$ , the observed number of Raman lines is also consistent with this model.

#### (b) Polysulphides

Infrared and Raman data have been reported<sup>85-88</sup> for H<sub>2</sub>S<sub>2</sub>, H<sub>2</sub>S<sub>3</sub>, H<sub>2</sub>S<sub>5</sub> and H<sub>2</sub>S<sub>6</sub>. The sulphur-hydrogen stretching frequency falls within the range 2480-2557 cm<sup>-1</sup>, and the sulphur-sulphur stretching frequency falls in the region 467-509 cm<sup>-1</sup>.

#### (c) Thiols

The sulphur-hydrogen stretching frequency in both the alkyl and aryl thiols appears<sup>89-92,385</sup> in the region 2564-2620 cm<sup>-1</sup>, but assignment of the bands within this region has been a matter of some controversy<sup>93-95</sup>. Cole, Little and Mitchell<sup>46</sup> have recently found bands at 2585 and 2572 cm<sup>-1</sup> in the infrared spectra of phenyl thiol in carbon tetrachloride, and have suggested that these result from the presence of

monomer and hydrogen-bonded cyclic dimer in solution. The S-H bonds lengths in thiols show little deviation<sup>97-102</sup>, and generally the S-H bond length is reported as 1.323-1.350 Å.

## 6. Boron

Boron trisulphide has been studied spectroscopically and its symmetry deduced from the spectra obtained. There are several plausible models for  $B_2S_3$ : a linear molecule ( $D_{\infty h}$ ), a bipyramidal ( $D_{3h}$ ), a plane V or W-shaped molecule ( $C_{2v}$ ) or a twisted zigzag ( $C_2$ ). Infrared emission and absorption spectra of gaseous  $B_2S_3$  have been observed for the normal isotopic mixture and for a sample prepared with  $^{10}B$  by Greene and Margrave<sup>103</sup>, and examination of the isotopic shifts with the aid of the Redlich-Teller product rule, gives support to a twisted zigzag model with  $C_2$  symmetry.

Six and four membered sulphur-boron ring compounds have been known for several years<sup>104</sup>, but few have been investigated spectroscopically. Recently Forster and Muetterties<sup>105</sup> have reported the infrared spectrum of  $(Et_2NBS)_2$  which has still to be assigned.

Organic boron-sulphur compounds have been recently reviewed by Cragg and Lappert<sup>111</sup> who have tabulated the  $\nu_{B-S}$  assignments for several types of cyclic molecules. In some cases the B-S bond is associated with two well separated absorption bands<sup>106,112-114</sup>, e.g., compounds of the type  $(RS)_3B$  have B-S stretching bands at  $910-1000\text{ cm}^{-1}$ , and  $740-755\text{ cm}^{-1}$  and  $(RS)_2BR'$  compounds have B-S stretching bands at  $1000-1100\text{ cm}^{-1}$  and  $740-755\text{ cm}^{-1}$ . The strong Raman bands for  $B(SET)_3$  at  $460$  and  $450\text{ cm}^{-1}$  are attributed to  $^{10}BS_3$  and  $^{11}BS_3$  symmetric stretching vibrations respectively<sup>106</sup>.

## 7. Carbon: Thiocyanates

In general the thiocyanate ion can coordinate either through nitrogen or sulphur, and many factors influence the way in which the group is bound. The C-N stretching frequency has been used<sup>107</sup> to distinguish between S- and N-bonding, since among complexes whose structures are known, those which are S-bonded generally have the higher values for the C-N stretching frequency. There is a certain amount of overlap however, and it has proved more useful to use the C-S stretching frequency which occurs at  $690-720\text{ cm}^{-1}$  and  $780-860\text{ cm}^{-1}$  for S bonded and N bonded complexes respectively<sup>108-110,115,116</sup>. Nuclear Magnetic Resonance has also been used to distinguish between N and S bonded groups, since in the S bonded complexes the  $^{14}N$  resonance is shifted downfield compared to the free  $SCN^-$  ion, and in N bonded complexes it is shifted upfield<sup>117</sup>.

Raman<sup>118</sup> and infrared<sup>119</sup> spectral evidence suggests that the predominant species present in molten and aqueous alkali metal thiocyanates is linear  $[\text{S}-\text{C}=\text{N}]^-$ . In N bonded complexes  $\text{M}-\text{N}\equiv\text{C}-\text{S}^-$  and  $\text{M}-\overset{+}{\text{N}}=\text{C}=\text{S}$  are predominant, and in S-bonded complexes  $\text{M}-\text{S}-\text{C}\equiv\text{N}$  is important<sup>108</sup>. Lewis, Nyholm and Smith<sup>108</sup> suggest that when the thiocyanate ion is the only ligand bound to a metal M, then the way in which the group is bound is decided by the relative bond energies of a covalent M-S bond and the more ionic M-N bond.

The position of the thiocyanate ion in the spectrochemical series<sup>49,120</sup> depends on whether it is S- or N-bonded, when S-bonded it occupies a position approximately equal to  $\text{Cl}^-$  but when N-bonded it lies between  $\text{H}_2\text{O}$  and  $\text{NH}_3$ .

Livingstone<sup>121</sup> has recently reviewed cyanates, thiocyanates and selenocyanates, and discusses the factors which influence the predominance of one canonical form over another.

The M-SCN linkage is always angular, but the M-NCS linkage can be collinear or angular with the M-N-C angle as low as  $111^\circ$ . The S-C bond length falls within the range 1.55–1.80 Å for both types of linkage<sup>122-126,586</sup>. Hazell has reported an apparent correlation between the M-N-C angle ( $110-180^\circ$ ) and the carbon-nitrogen and sulphur-carbon distances<sup>586</sup>, the sulphur-carbon bond lengths are generally shorter than predicted; this may be attributed to  $d_\pi-p_\pi$ -bonding between sulphur and carbon atoms.

## 8. Silicon, germanium, tin and lead

The infrared and Raman spectra of disilyl sulphide,  $(\text{H}_3\text{Si})_2\text{S}$ , have been studied in detail<sup>127,128</sup>. The intense and polarised Raman line at  $480\text{ cm}^{-1}$ , assigned to the symmetrical skeletal stretching mode also occurs in the infrared. A strong band at  $517\text{ cm}^{-1}$ , not shifted by deuteration, is assigned to the asymmetric stretch and appears in both spectra. There is therefore little doubt that the Si-S-Si skeleton is non-linear<sup>127</sup>, a value of about  $100^\circ$  has been proposed for the Si-S-Si angle. Low temperature infrared spectra suggest a  $\text{C}_{2v}$  molecular symmetry. Infrared and Raman data (frequency assignments, selection rules and band envelopes) for  $\text{S}(\text{GeH}_3)_2$  have been used<sup>137</sup> to deduce that the Ge-S-Ge angle is approximately  $120^\circ$ . Hooton and Allred<sup>129</sup> have tentatively assigned the Si-S and Ge-S stretching frequencies in organo silyl and germyl sulphides, and Schumann and Schmidt<sup>130</sup> have examined the stretching frequency of Sn-S and Pb-S bonds in compounds of the type  $\text{Ph}_3\text{M}-\text{S}-\text{MPh}_3$ . The available data are summarised in Table 5.3.

TABLE 53

FREQUENCY RANGES OF CHARACTERISTIC ABSORPTIONS OF SOME GROUP IV ELEMENTS BONDED TO SULPHUR

		References		References
$\nu(\text{Si-S})$	430-600 $\text{cm}^{-1}$	129, 130	$\nu(\text{Sn-S})$	267-392 $\text{cm}^{-1}$ , 130
$\nu(\text{Si-S-Si})$	400-530 $\text{cm}^{-1}$	{129, 132 135, 136}	$\nu(\text{Sn-S-Sn})$	330-380 $\text{cm}^{-1}$ 130 135
$\nu(\text{Ge-S})$	400 $\text{cm}^{-1}$	130 131	$\nu(\text{Pb-S})$	305 $\text{cm}^{-1}$ 130
$\nu(\text{Ge-S-Ge})$	385-420 $\text{cm}^{-1}$	130 135	$\nu(\text{Pb-S-Pb})$	275-340 $\text{cm}^{-1}$ 130 135

137

## 9. Nitrogen

### (a) Spectral data

Relatively little data on sulphur-nitrogen stretching frequencies have been reported. Since bond orders of up to three can occur a considerable range of frequency is observed (see Fig. 5.4). In this respect the situation is akin to that encountered with respect to sulphur-oxygen bonds (section 12), but whereas in this latter case several correlations between stretching frequency and other bond properties have been found, no such correlations are reported in the case of sulphur-nitrogen compounds. Since the nature of the bonding in sulphur-oxygen and sulphur-nitrogen systems is analo-

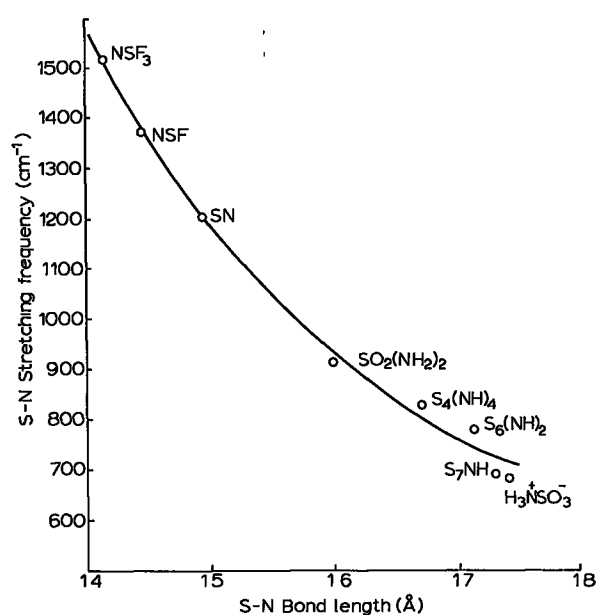

Fig. 5.4 Correlation of S-N stretching frequencies and bond lengths

Nickless Ch 5-18 1st proof

gous, similar relationships might be expected to hold. Unfortunately the available data are limited but as presented in Fig 5.4 they do suggest a correlation between the sulphur–nitrogen stretching frequency and bond length (*cf* Fig 5.8 for the similar S–O correlation). The scatter in the points is never greater than  $\pm 0.02 \text{ \AA}$ , which is only about twice the estimated error of the more accurate bond lengths used.

TABLE 5.4  
SULPHUR–NITROGEN STRETCHING FREQUENCIES

Grouping	Compound type	$\nu_{\text{SN}}(\text{cm}^{-1})$	References
N–S–N	cyclic $\text{S}_n(\text{NR})_{8-n}$	770–840	142–149
N–SO <sub>2</sub> –N	sulphamide and derivatives	900–930	150, 151
C–SO <sub>2</sub> –N	sulphonamides	800–920	152–155
C–S–N	alkyl thionitrites	620–640	156
N–SO <sub>3</sub> <sup>-</sup>	sulphamic acid	682	
	sulphamates	788	138, 139
(–N=) <sub>n</sub> SF <sub>2</sub>	(RN=) <sub>2</sub> SF <sub>2</sub>	1404–1428	157
	RN=SF <sub>2</sub>	1350–1400 <sup>a</sup>	158, 159
	PhN=S(OMe) <sub>2</sub>	1280	160
N≡S–	NSF	1372	161
N≡S≡	NSF <sub>3</sub>	1515	161
	NS(F <sub>2</sub> )NEt <sub>2</sub>	1515	162
	SN (short lived)	1204	163
	(SN) <sub>n</sub> polymer	1225, 1015	163

<sup>a</sup> except the fluorocarbon-compound<sup>160</sup> C<sub>3</sub>F<sub>7</sub>N=SF<sub>2</sub> for which  $\nu_{\text{SN}} \approx 1275 \text{ cm}^{-1}$

The available spectral data is summarised in Table 5.4 the lowest S–N stretching frequencies are observed for sulphamic acid ( $682 \text{ cm}^{-1}$ ) and alkyl thionitrites ( $\sim 630 \text{ cm}^{-1}$ ). For sulphamic acid, Vuagnat and Wagner<sup>138</sup> and Nakagawa *et al.*<sup>139</sup> agree in assigning  $\nu_{\text{SN}}$  to a band at  $\sim 685 \text{ cm}^{-1}$ , but Bicelli<sup>140,141</sup> assigned a band at  $\sim 565 \text{ cm}^{-1}$  to  $\nu_{\text{SN}}$ . Vuagnat and Wagner<sup>138</sup> assigned this latter band to an –SO<sub>3</sub> deformation. Compounds containing a formal sulphur–nitrogen double bond may absorb over a wide range,  $1280\text{--}1500 \text{ cm}^{-1}$ , the frequency at which a given compound absorbs being apparently very sensitive to the presence of substituents on either the sulphur or the nitrogen atoms. If the double bond is described in terms of  $\sigma$  and  $\pi$  components then the observed variations in frequency may be considered to a first approximation to reflect changes in the  $\pi$ -bond order resulting from the electronic effects of the substituents. Few compounds containing SN triple bonds are reported, the frequency observed for NSF ( $1372 \text{ cm}^{-1}$ ) suggests that its bond order is less than that in NSF<sub>3</sub> ( $1515 \text{ cm}^{-1}$ )<sup>161</sup>.

Cyclic compounds of the type  $\text{S}_n(\text{NR})_{8-n}$ , where R=H or CH<sub>3</sub>, absorb in the range  $770\text{--}840 \text{ cm}^{-1}$ , when R=CH<sub>3</sub> the absorption occurs toward the lower end of this range. Splitting of the band into two components may take place if the >NR groups are sufficiently close together<sup>147</sup>. The  $\pi$ -delocalised systems  $\text{S}_4\text{N}_4$ <sup>142</sup> and  $\text{S}_4\text{N}_3^+$ <sup>164</sup>,

<sup>165</sup> give rise to several bands involving S-N stretching but the precise origins of each absorption have not been determined. The spectra of some sulphuric compounds (NSOX)<sub>3</sub>, where X=Cl<sup>166</sup>, F<sup>167</sup>, are reported but not assigned.

(b) Structural data

The reported structural data are given in Table 5.5. Many of the reported bond lengths are intermediate between the values calculated<sup>168</sup> for a single bond (1.73 Å)

TABLE 5.5  
BOND DISTANCES AND ANGLES IN SULPHUR-NITROGEN COMPOUNDS

Compound	r <sub>S-N</sub> (Å)	∠NSN	∠NSX, SNX	References
SN <sup>+</sup> (short lived)	1.250			176
SN (short lived)	1.495			177
S <sub>4</sub> N <sub>4</sub>	1.616±0.010	104.5±1.5°		178, 179
S <sub>4</sub> N <sub>4</sub> H <sub>4</sub>	1.674±0.012	108.4°	122.2° (SNS)	172, 180
S <sub>4</sub> N <sub>4</sub> F <sub>4</sub>	1.660±0.01 (S-N)	111.7±0.6°	91.5±0.4° (FS-N)	173
	1.540±0.01 (S=N)		106.2±0.4° (FS=N)	
S <sub>4</sub> N <sub>3</sub> NO <sub>3</sub>	1.54±0.04	118.9±1.5°	152.4±1.3° (SNS)	182, 183
			134.4±1.2° (SNS)	
			111.3±1.0° (SSN)	
S <sub>7</sub> NH	1.73		115.8 (SNS)	184
			108.6 (NSS)	
1,4-S <sub>6</sub> (NH) <sub>2</sub>	1.73		110° (NSS)	185
			118° (SNS)	
1,5-S <sub>6</sub> (NH) <sub>2</sub>	1.62		112.3, 107.2 (NSS)	186
	1.68		120.3, 117.3 (SNS)	
N <sub>3</sub> S <sub>3</sub> Cl <sub>3</sub>	1.605±0.01	113.4±0.5°	123.8±0.5 (SNS)	187
			113.8±0.5 (NSCl)	
N <sub>3</sub> S <sub>3</sub> O <sub>3</sub> Cl <sub>3</sub>	1.571±0.004	112.8±0.4°	122.0±0.4 (SNS)	181
			106.3±0.3 (NSCl)	
			111.9±0.4 (NSO)	
SO <sub>2</sub> (NH <sub>2</sub> ) <sub>2</sub>	1.600±0.009	112.1±0.7°		171
SO <sub>2</sub> [N(CH <sub>3</sub> ) <sub>2</sub> ]	1.623±0.005	112.6±0.4°		170
S <sub>3</sub> N <sub>2</sub> O <sub>2</sub>	1.58	120.0°		189
	1.69			
H <sub>3</sub> <sup>+</sup> NSO <sub>3</sub>	1.764±0.020			190
H <sub>2</sub> NSO <sub>3</sub> K	1.60±0.03			191
KNH(SO <sub>3</sub> ) <sub>2</sub>	1.655±0.005		124.7±0.5° (SNS)	192
KNHOH(SO <sub>3</sub> )	1.67±0.02			193
(NH <sub>4</sub> ) <sub>2</sub> SO <sub>3</sub> (N <sub>2</sub> O <sub>2</sub> )	1.79±0.01		116.5° (SNN)	169
			103.9° (NSO)	
NSF	1.446			161
NSF <sub>3</sub>	1.416			161

and for a double bond (1.54 Å). It is generally accepted that the bonds possess some π character as a result of overlap involving the lone pair electrons on the nitrogen atom and the empty 3d-orbitals of the sulphur atom<sup>169-172</sup>. Wiegers and Vos<sup>173a</sup> have,

Nickless Ch 5 21 1st proof

however, commented that a conclusive explanation of relative sulphur–nitrogen bond lengths has not yet been given. In  $S_4N_4$ <sup>174</sup> and  $S_4N_3^+$ <sup>175</sup> dimensions and also electronic spectra have been rationalised using a molecular orbital treatment. Pure single S–N bonds are rarely encountered. The value reported for 1,4- $S_6(NH)_2$  of 1.73 Å results from a preliminary refinement only, so that  $S_7(NH)$ , (1.73 Å),  $H_3NSO_3^-$  (1.76 Å), and  $(NH_4)_2SO_3(N_2O_2)$  (1.79 Å) are the only reliable examples of compounds containing S–N single bonds. The bond length in  $S_7(NH)$  may be contrasted with the shorter bonds found in  $S_4(NH)_4$  (1.67 Å), and 1,5- $S_6(NH)_2$  (1.62, 1.68 Å). In the case of the sulphamate and dinitrosulphite ions the sulphur 3d-orbitals are utilised in the  $\pi$ -bonding systems of the  $-SO_3$  and  $-SO_3(N_2O_2)$  groups, (the S–O bond lengths in both ions correspond approximately to double bonds) so that the sulphur–nitrogen bond is restricted to two  $\sigma$ -electrons only. Data in Table 5.4 suggest that in some

TABLE 5.6  
SYMMETRIC AND ASYMMETRIC STRETCHING FREQUENCIES OF NSO COMPOUNDS

Compound type	$\nu_s$ ( $cm^{-1}$ )	$\nu_{as}$ ( $cm^{-1}$ )	References
RNSO	1120–1135	1238–1252	194
$A_1NSO$	1137–1179	1272–1300	195
$A_1SO(=NH)N(CH_3)_2$	1135–1160	1260–1270	196
$A_1SO(=NH)OC_6H_5$	1160	1295	196
$R_2SO(=NH)$	1099	1212	196
$(NSOF)_n$	1250	1351	197
$RN=SO_2F$	1219–1320	1428–1492	198, 199

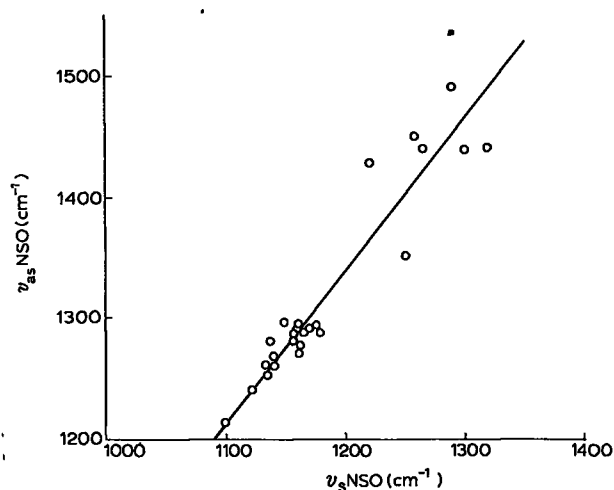

Fig. 5.5 Correlation of symmetric ( $\nu_s$ , NSO) and asymmetric ( $\nu_{as}$ , NSO) stretching frequencies of the NSO group

compounds which formally contain S-N single bonds, e.g., sulphonamides and sulphamides, considerable  $\pi$ -bonding may occur since for these compounds  $\nu_{\text{SN}}$  (800–930  $\text{cm}^{-1}$ ) is at a higher frequency than that which is associated with the single bond in sulphamic acid (682  $\text{cm}^{-1}$ ). The spectra of several other S-N compounds<sup>237–243</sup> are reported without assignment of  $\nu_{\text{SN}}$ .

Compounds containing the NSO group give rise to symmetric and asymmetric stretching modes. The available data are listed in Table 5.6, and in Fig 5.5 the symmetric stretching frequency ( $\nu_s$ ) is plotted against the asymmetric frequency ( $\nu_{as}$ ). Though the data are somewhat limited a reasonably satisfactory relationship is observed. In this respect the NSO group may be compared with the  $\text{SO}_2$  group for which a similar relationship is well established (section 12.a)

TABLE 5.7

P=S STRETCHING FREQUENCIES OF COMPOUNDS XYZR=S

Compound			Frequency, $\nu_{\text{PS}}$ ( $\text{cm}^{-1}$ )		References
X	Y	Z	Raman	Infrared	
F	F	F	695	g 694	216, 609, 614
F	F	Cl	729		216
F	F	Br	711		216
Cl	Cl	F	737		217
Cl	Cl	Cl	753	751, g 768	215, 606, 614
Cl	Cl	Br	743		215
Br	Cl	F	729		217
Br	Br	F	713		217
Br	Br	Cl	729		215
Br	Br	Br	718		215
I	I	I		1 673	603
Me	Me	Me		s 570	598, 200
Et	Et	Et		s 538, 1 552	598, 200
n-Pr	n-Pr	n-Pr		583, 596	598
n-Bu	n-Bu	n-Bu		596	598, 605
n-Am	n-Am	n-Am		588, 599	598
$\text{C}_6\text{H}_{11}$	$\text{C}_6\text{H}_{11}$	$\text{C}_6\text{H}_{11}$		s 619	598
$\text{CF}_3$	$\text{CF}_3$	$\text{CF}_3$		x 800	604
SMe	SMe	SMe		685	223
SEt	SEt	SEt		685	218, 223
Ph	Ph	Ph		s 627	598
Cl	Cl	Me	671	672, g 696	219, 218
Cl	Cl	Et		646, 676	200
Cl	Cl	OMe		705, 725	218
Cl	Cl	OEt		695, 725	218
OMe	OMe	H		633, 654	218
OMe	OMe	OMe		603, 620	200, 221
OMe	OMe	SH		660	218



## 10. Phosphorus

Phosphorus-sulphur linkages are of two main types, (i) terminal, P=S and (ii) bridge, P-S- Infrared and Raman data are available for both types

The effect of the nature of X on the P=O or P=S stretching frequencies of POX<sub>3</sub> and PSX<sub>3</sub> compounds has been discussed in detail<sup>28,200,201,598,599,610,611</sup> The P=S force constant has been calculated<sup>202</sup> to be  $4.2 \times 10^5$  dyne cm<sup>-1</sup> for PSCl<sub>3</sub> and this value leads to a P=S stretching frequency of 675 cm<sup>-1</sup> for an isolated P=S group The thiophosphoryl halides<sup>539</sup> absorb in the region 695-753 cm<sup>-1</sup> Replacement of halogen by alkyl or alkoxy groups shifts this region down to 535-725 cm<sup>-1</sup> (see Table 5 7; some compounds give rise to two peaks) The highest observed frequency

Compound			Frequency, $\nu_p$ (cm <sup>-1</sup> )		References
X	Y	Z	Raman	Infrared	
OMe	OMe	SMe		660	218
OMe	OMe	Cl		660	218
OEt	OEt	H		636, 658	218
OEt	OEt	OH		618, 655	218
OEt	OEt	OEt		580, 600	200, 220
OEt	OEt	OEt	610, 629		200, 222
OEt	OEt	SH		660	218, 220
OEt	OEt	SEt		660	218
OEt	OEt	SCl		652	214, 612
OEt	OEt	Cl		655	218, 220
OEt	OEt	CCl <sub>3</sub>		635	612
Ph	Ph	Me		609, 618	598
Ph	Ph	Et		s 598, 599 <sup>a</sup> , 601 <sup>a</sup>	598
Ph	Ph	n-Bu		s 605, 617	598
Ph	Ph	Cl		660	598
Me	Me	Ph		s 585	598
Me	Me	P(S)Me <sub>2</sub>		s' 568, 1' 572	608
Et	Et	Ph		578	598
1-Pt	1-Pt	SH		595	605
1-Pt	1-Pt	Cl		593	605
n-Bu	n-Bu	Ph		597	598
s-Bu	s-Bu	SH		617	605
s-Bu	s-Bu	Cl		626	605
I	I	P(S)I <sub>2</sub>		s' 725	607

s - spectrum of solid in KBr disc

<sup>a</sup> shoulders on absorption peak

s' - spectrum of solid in Nujol mull

1 - spectrum of solution in CS<sub>2</sub>

1' - spectrum of solution in CHCl<sub>3</sub>

g - gas spectrum

x - conditions not recorded

Pure liquid used for all other spectra

Nickless

Ch 5 23

1st proof

for the P=S fundamental vibration is that at  $860\text{ cm}^{-1}$  for  $\text{PS}(\text{NH}_2)_3$ <sup>600</sup>. These shifts are apparently<sup>203,204,598</sup> caused, as in the case of phosphoryl compounds, by a combination of four variables mass and steric effects of the groups attached to phosphorous, their inductive effect and  $\pi$  donation by halogen, particularly fluorine, to phosphorous. Slight shifts are also caused by coupling of the P-X and P=S vibrations when their natural frequencies are close.

The infrared spectra of numerous organic derivatives of thiophosphoric acids have been studied<sup>205-209</sup>. Two bands of widely different frequency have been found to be characteristic of terminal P=S bonds. These occur within the overall ranges  $625-862\text{ cm}^{-1}$  and  $530-730\text{ cm}^{-1}$ . Both bands appear to be characteristic of the P=S bond, since both disappear during the isomerisation of phosphorothionates to phosphorothiolates

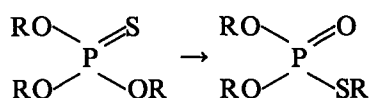

No wholly satisfactory explanation of their origin has so far been suggested. The infrared spectra of the diphenyl thiophosphates of dimethyl aluminium and gallium ( $[\text{Me}_2\text{MOP}(\text{S})\text{Ph}_2]_2$ ) have been reported and the S-P stretching frequencies are consistent with a dimeric structure with donation through the sulphur atoms<sup>210</sup>. The overall frequency limits within which stretching vibrations of the P-S-(X) bond are found are  $440-613\text{ cm}^{-1}$ . Chittenden and Thomas<sup>209</sup> have discussed the effects of changes in the nature of the substituent groups attached to phosphorus on the P=S stretching frequency and have tabulated the infrared absorption frequencies of the P=S, P-S-(C), P-S-(P), P-S-(H) and P=Se bonds as a function of the overall chemical structure of the molecule

Phosphorotetrathioates have been found<sup>205</sup> to absorb strongly in the region  $520-570\text{ cm}^{-1}$ . Dialkylphosphorodithioates of Zn, Ni and Pb are reported to show P=S absorptions at  $625-665\text{ cm}^{-1}$  and P-S at  $530-560\text{ cm}^{-1}$ . Compounds of the general type  $\text{XS-P}(\text{S})(\text{OR})_2$  (X = alkyl, acyl) show a well defined P=S absorption in the region  $640-680\text{ cm}^{-1}$ , the frequency decreasing with the electronegativity of X<sup>207</sup>. Phosphoromonothioates<sup>206</sup> absorb near  $560\text{ cm}^{-1}$ .

The force constant for the P-S single bond in  $\text{P}_4\text{S}_3$  has been calculated<sup>211</sup> to be  $1.65 \times 10^5\text{ dyne cm}^{-1}$ . This would lead, in an isolated P-S bond to a vibration frequency of  $422\text{ cm}^{-1}$ . It has been found<sup>205,208,212,213</sup> that P-S bonds with bridging sulphur generally absorb in the region  $400-700\text{ cm}^{-1}$ .

Corbridge<sup>205</sup> tentatively suggested  $400-500\text{ cm}^{-1}$  as the absorption region characteristic of P-S-P linkages. McIvor and Hubley<sup>208</sup> investigated over 40 organophosphorus compounds containing sulphur. Weak diffuse bands at  $488\text{ cm}^{-1}$  for two P-S-P compounds were ascribed to the P-S links. Their conclusions as regards P=S absorption (terminal sulphur) agree with the findings of Hooge and

Nickless Ch 5 84 1st proof

Christen<sup>200</sup> (described above and in Table 5.7). Compounds  $[(RO)_2P(S)]_2S$  show<sup>214</sup> a fairly strong absorption due to P-S-P at  $485-515\text{ cm}^{-1}$ .

P-S-H compounds absorb at similar frequencies, phosphorodithioic acids<sup>208</sup> at  $493-548\text{ cm}^{-1}$  and  $(CF_3)_2P-S-H$  at  $508$  and  $522\text{ cm}^{-1}$   $\nu_{PS}$  in other  $(CF_3)_2P-SX$  compounds<sup>212</sup> [ $X = \text{Me, t-Bu}$  and  $-P(CF_3)_2$ ] occurs at  $508-530\text{ cm}^{-1}$

Structural data for sulphur-phosphorus compounds are given in Table 5.8

TABLE 5.8  
SULPHUR-PHOSPHORUS BOND LENGTHS AND ANGLES

Compound	$r_{P-S}$ (Å)	P-S-P(°)	References
SPe <sub>3</sub>	1.86		224
SPF <sub>3</sub>	1.85		225
(S <sub>2</sub> P(OMe) <sub>2</sub> ) <sub>2</sub> K	1.96		226
P <sub>2</sub> S <sub>6</sub> Br <sub>2</sub>	1.98		227
BPS <sub>4</sub>	2.16		228
K <sub>3</sub> PS <sub>4</sub>	2.02, 2.04 2.08, 2.08		229
(CH <sub>3</sub> PS <sub>2</sub> ) <sub>2</sub>	1.94 (exocyclic) 2.14 (cyclic)	$85.46 \pm 0.23$	230, 231
P <sub>4</sub> S <sub>3</sub>	2.10	102	232, 233
P <sub>4</sub> S <sub>5</sub>	1.94 (exocyclic) 2.08-2.21 (cyclic)	108, 102, 99 and 88	234
P <sub>4</sub> S <sub>7</sub>	1.95 (exocyclic) 2.08 (cyclic)	106	235, 236
P <sub>4</sub> S <sub>10</sub>	1.95 (exocyclic) 2.08 (cyclic)	$109 \pm 1$	235

## 11. Arsenic and antimony

The intense band located in the range from  $470-490\text{ cm}^{-1}$  in the spectra of the trialkylarsine sulphides has been assigned<sup>245</sup> to the fundamental arsenic-sulphur stretching frequency. The assignment of  $\nu_{As-S}$  in monosubstituted arsine sulphides and in arsine sulphides bearing phenyl and cyclohexyl groups cannot be made with the high level of confidence possible for the trialkyl compounds. Bands at  $490\text{ cm}^{-1}$  and  $476\text{ cm}^{-1}$  have been assigned with reasonable certainty to the As-S stretching vibration in triphenyl- and tricyclohexyl arsine sulphides respectively. The As-S stretching frequency has been found to depend almost entirely upon the mass of the organic constituents on the arsenic atom<sup>245</sup>. There is a brief reference<sup>244</sup> to Raman shifts for  $Na_3AsO_3S$ ,  $Na_3AsO_2S_2$ ,  $Na_3AsOS_3$ ,  $Na_3AsS_4$ , and  $Na_3SbS_4$ .

## 12. Oxygen

### (a) Sulphuryl ( $-\text{SO}_2-$ ) compounds

The infrared and Raman spectra of compounds containing sulphur-oxygen bonds have been extensively studied and several useful correlations have been established. For  $-\text{SO}_2-$  compounds several workers<sup>19,28,246</sup> have observed a linear relationship between the symmetric S-O stretching ( $\nu_s\text{SO}$ ) and the asymmetric stretching vibration ( $\nu_{as}\text{SO}$ ). Bellamy and Williams<sup>246</sup> have commented that such a relationship is to be expected since the  $-\text{SO}_2-$  stretching vibrations are essentially free from mass and

TABLE 59

SYMMETRIC AND ASYMMETRIC STRETCHING VIBRATIONS FOR OXO-ANIONS OF SULPHUR

Species	$\nu_s$ ( $\text{cm}^{-1}$ )	$\nu_{as}$ ( $\text{cm}^{-1}$ )	References
$\text{SO}_3^{2-}$	970	930	264
$\text{FSO}_2^-$	1105	1182	265
$\text{SO}_4^{2-}$	981	1104	266
$\text{S}_2\text{O}_3^{2-}$	995	1123	267
$\text{S}_2\text{O}_6^{2-}$	1092	1235	268
	1000	1206	
$\text{S}_2\text{O}_7^{2-}$	1059	1267	269
	1108	1289	

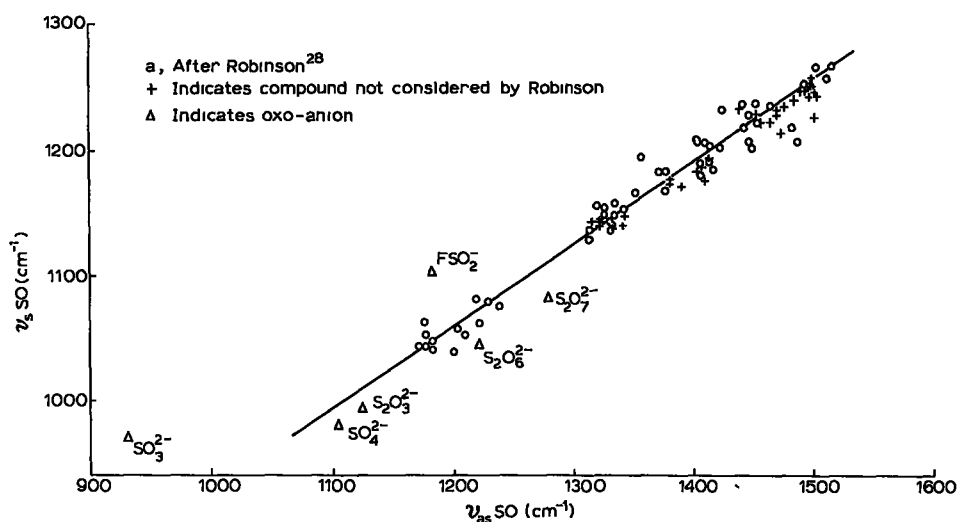

Fig. 56 Correlation of symmetric and asymmetric S-O stretching frequencies<sup>a</sup>

<sup>a</sup>, after Robinson<sup>28</sup> + indicates compound not considered by Robinson Δ indicates oxo-anion

coupling effects. The data compiled by Robinson<sup>28</sup> is particularly comprehensive and shows that the symmetric and asymmetric S-O vibrations for compounds of the types X<sub>2</sub>SO<sub>2</sub>, (including X(OH)SO<sub>2</sub>), for ions such as XSO<sub>3</sub><sup>-</sup> and SO<sub>4</sub><sup>2-</sup> and for more complex molecules containing -SO<sub>2</sub>- vibrations or inaccuracy in the reported values because of the difficulty of resolving bands in the fairly complex spectra. On the other hand, the values for the SO<sub>3</sub><sup>2-</sup> and FSO<sub>2</sub><sup>-</sup> ions lie well away from the line. All of the compounds reported by Robinson contain sulphur in the S(VI) state, as do the oxo-anions which fit the linear relationship. The ions SO<sub>3</sub><sup>2-</sup> and FSO<sub>2</sub><sup>-</sup>, however, contain S(IV), which perhaps suggests that the line established by Robinson is applicable only to compounds containing S(VI).

Table 5.10 lists the frequencies observed for various types of -SO<sub>2</sub>- compounds. It is seen that, in general, as the effective electronegativity of the groups attached to the -SO<sub>2</sub>- group is increased the S-O stretching vibrations are shifted to higher

TABLE 5.10  
CORRELATION TABLE FOR S-O SYMMETRIC AND ASYMMETRIC VIBRATIONS<sup>a</sup>

Grouping	Type of compound	$\nu_{s-o}(\text{cm}^{-1})$	
		symmetrical	asymmetrical
C-SO <sub>2</sub> -C	Sulphones(alkyl)	1136-1145	1307-1330
	Sulphones(alkyl-aryl)	1150-1160	1325-1334
	Sulphones(aryl)		
C-SO <sub>2</sub> -N	Sulphonamides	1152-1169	1336-1358
C-SO <sub>2</sub> -N	<i>e.g.</i> , F <sub>3</sub> CSO <sub>2</sub> N <sub>3</sub>	1236	1437
C-SO <sub>2</sub> -O	Sulphonic acids and esters	1165-1185	1350-1375
C-SO <sub>2</sub> -F	Sulphonyl fluorides	1203-1210	1401-1412
C-SO <sub>2</sub> -Cl	Sulphonyl chlorides	1169-1185	1364-1390
C-SO <sub>2</sub> -S	Thiosulphonates	1144-1154	1331-1342
N-SO <sub>2</sub> -N	Sulphamide and derivatives <sup>b</sup>	1140-1168	1320-1398
O-SO <sub>2</sub> -O	Covalent sulphates	1187-1195	1390-1415
O-SO <sub>2</sub> -O	<i>e.g.</i> , (SF <sub>5</sub> O) <sub>2</sub> SO <sub>2</sub> and SF <sub>5</sub> O SF <sub>4</sub> O SO <sub>2</sub> OSF <sub>2</sub> <sup>b</sup>	1230-1256	1469-1500
O-SO <sub>2</sub> -F	<i>e.g.</i> , FSO <sub>3</sub> F, HSO <sub>3</sub> F,	1230-1260	1445-1510
	S <sub>2</sub> O <sub>5</sub> F <sub>2</sub> , S <sub>2</sub> O <sub>8</sub> F <sub>2</sub> <sup>c</sup>		
O-SO <sub>2</sub> -Cl	<i>e.g.</i> , HSO <sub>3</sub> Cl, S <sub>2</sub> O <sub>5</sub> Cl <sub>2</sub> ,	1205-1225	1408-1452
	S <sub>2</sub> O <sub>8</sub> Cl <sub>2</sub> , S <sub>3</sub> O <sub>8</sub> Cl <sub>2</sub>		
N-SO <sub>2</sub> -F	=NSO <sub>2</sub> F and -N(SO <sub>2</sub> F) <sub>2</sub> compounds <sup>b</sup>	1174-1250	1337-1495
	SO <sub>2</sub> F	1269	1502
	SO <sub>2</sub> Cl <sub>2</sub>	1182	1414
	Ions, <i>e.g.</i> , FSO <sub>3</sub> <sup>-</sup>	1026-1080	1175-1221
	MeSO <sub>3</sub> <sup>-</sup> , excluding oxo-anions <sup>d</sup>		

<sup>a</sup> after Robinson<sup>28</sup>

<sup>b</sup> groupings not given by Robinson

<sup>c</sup> these frequency ranges confirmed by inclusion of data not considered by Robinson

<sup>d</sup> frequency ranges for oxo-anions are in section 12 b

frequencies This shift indicates increasing strength of the S-O bonds which is most plausibly explained as resulting, at least in part, from increased double bond character (*cf* section 12 e)

(b) Oxo-anions and complexes

The characteristic ranges over which the S-O stretching vibrations in oxo-anions occur are given in Fig 5 7 For the less common anions the ranges shown are based

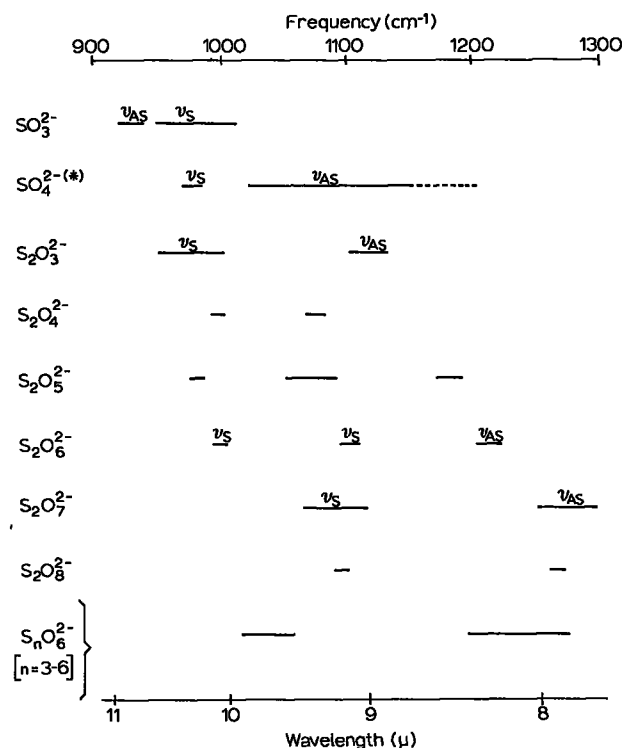

Fig 5 7 Observed frequency ranges of S-O stretching vibrations in oxo-anions  
 \* The range for SO<sub>4</sub><sup>2-</sup> is normally 1020-1150 cm<sup>-1</sup>, relatively few compounds absorb at 1150-1200 cm<sup>-1</sup>

upon only a few reported spectra, usually of alkali metal salts, and are, therefore, somewhat tentative

Few XSO<sub>2</sub><sup>-</sup> ions have been studied Houlton and Tartar<sup>277</sup> examined the Raman spectra of several sodium alkyl sulphinites and observed S-O stretching modes at 942-956 cm<sup>-1</sup> and 1024-1046 cm<sup>-1</sup>, though these were not assigned to any specific vibrations Paetzold and Aurich<sup>265</sup> have assigned bands at 1182 and 1105 cm<sup>-1</sup> for potassium fluorosulphite to the asymmetric and symmetric S-O stretching vibrations respectively

(i) Sulphates

The free ion has tetrahedral,  $T_d$ , symmetry and hence four fundamental modes for which the calculated frequencies, assuming central forces<sup>266</sup>, are:

$$\begin{aligned} \nu_1 \text{ (symmetric stretch), } & 981 \text{ cm}^{-1}, & \nu_2 \text{ (degenerate bend), } & 451 \text{ cm}^{-1} \\ \nu_3 \text{ (asymmetric stretch), } & 1104 \text{ cm}^{-1}, & \nu_4 \text{ (degenerate bend), } & 613 \text{ cm}^{-1} \end{aligned}$$

$\nu_2$  is doubly degenerate and both  $\nu_3$  and  $\nu_4$  are triply degenerate. All four modes are Raman active but only  $\nu_3$  and  $\nu_4$  are active in the infrared. The observed Raman frequencies in various crystalline environments are given in Table 5.11. It is seen that doubly and triply degenerate modes may split into two and three components respectively. Infrared spectra<sup>271,278</sup> normally show only bands due to  $\nu_3$  and  $\nu_4$  though in some cases slight lowering of the symmetry brought about by crystal forces causes  $\nu_1$  to become weakly infrared active<sup>271</sup>.

TABLE 5.11

RAMAN FREQUENCIES OF SULPHATE IONS IN VARIOUS CRYSTALLINE ENVIRONMENTS<sup>a</sup>

Compound	$\nu_1$ ( $\text{cm}^{-1}$ )	$\nu_2$ ( $\text{cm}^{-1}$ )	$\nu_3$ ( $\text{cm}^{-1}$ )	$\nu_4$ ( $\text{cm}^{-1}$ )
$\text{Na}_2\text{SO}_4$	983	454	1106	622
$\text{BaSO}_4$	989	{ 453 462	{ 1094 1142 1167	{ 617 630 648
$\text{CaSO}_4$	1018	{ 415 499	{ 1108 1128 1160	{ 609 628 674

<sup>a</sup> from Krishnan<sup>279</sup>

Whilst the perturbing effect of the cation on the sulphate ion symmetry is usually small, in the case of indium sulphate<sup>280</sup> it is sufficiently great for new polarised lines to appear in the Raman spectrum, and these have been accounted for in terms of a  $\text{InSO}_4^-$  species of  $C_{3v}$  symmetry. Decius<sup>281,282</sup> has shown that when the alkaline earth sulphates are present in small amounts in KBr or KCl crystals, the ion symmetry is reduced to  $C_{2v}$ . The general effects of crystal forces on the spectra of solid sulphates have been discussed by several workers<sup>61,283-287</sup> as have the differences between solid and solution spectra, which result from the lower symmetry of the solid phase<sup>68,69,288</sup>. Guerchais *et al*<sup>284</sup> have related displacements of the  $\nu_1$  and  $\nu_3$  bands to the ionic radius of the cation in a series of alkali metal sulphates. The displacement is a linear function of the ionic radius of the cation, the shift being to lower frequency with increasing ionic radius.

The spectra of hydrated sulphates may differ from those of the corresponding anhydrous salts, usually as a result of hydrogen bond formation<sup>64,289-293</sup>. For compounds of the type  $\text{M}(\text{H}_2\text{O})_6\text{SO}_4 \cdot \text{H}_2\text{O}$ , where  $\text{M} = \text{Mg, Ni, Co, and Zn}$ ,  $\nu_3$  is at  $\sim 1085 \text{ cm}^{-1}$  compared with approximately  $1150 \text{ cm}^{-1}$  for the anhydrous com-

pounds<sup>64</sup> Cho *et al.*<sup>294</sup> have suggested that  $\text{MgSO}_4 \cdot \text{H}_2\text{O}$  exists in the form  $\text{Mg}(\text{OH})\text{HSO}_4$  because of the presence of a band at  $\sim 870 \text{ cm}^{-1}$  which they assign to the  $\text{HSO}_4^-$  ion. On the other hand, Oswald<sup>293</sup> having studied the infrared and NMR spectra of a series of monohydrates, concluded that the forms  $\text{MSO}_3(\text{OH})_2$  and  $\text{M}(\text{OH})\text{HSO}_4$  were not present and that the compounds were normal sulphates containing strongly bound water molecules. Tai and Underwood<sup>295</sup> have combined freeze drying with the KBr disc technique to study the infrared spectra of aqueous sulphate solutions. The shape of the  $\nu_3$  band at  $\sim 1120 \text{ cm}^{-1}$  was found to vary with the cation and they suggest that the sharp band of  $\text{K}_2\text{SO}_4$  is the most suitable for analytical purposes.

Considerably more data on the Raman and infrared spectra of the sulphate ion is reported. Ammonium and group 1 sulphates are reported in refs<sup>61,66,296-298</sup>, group 2 compounds in refs<sup>299-301</sup>, group 3 compounds in ref.<sup>302</sup>, and compounds containing transition metal ions in refs<sup>303-309</sup>. Compounds of the type  $(\text{NH}_4)_2\text{M}_2\text{H}_2\text{O}$  have been considered by Ananthanarayanan<sup>310</sup>. The infrared spectrum of iodosulphate shows the  $(\text{IO})^+$  cation to be polymeric<sup>311</sup>. Several workers<sup>301,312-319</sup> have discussed the spectrum of sulphuric acid, which provides evidence concerning possible ionisation processes. The general spectral characteristics of the sulphate ion are reported by various other workers<sup>41,320-323</sup>; Jaulmes<sup>324</sup> and Keller, Spotts and Biggs<sup>325</sup> have examined the spectra of sulphate minerals and Buijs<sup>326</sup> has examined the spectrum of the sulphate ion when absorbed on an ion exchange resin.

#### (ii) Thiosulphates

The free ion has tetrahedral  $C_{3v}$  symmetry and hence six fundamental modes all infrared and Raman active. The calculated frequencies<sup>267</sup> are.

$$\begin{array}{ll} \nu_1 \text{ (symmetric S-O stretch), } 995 \text{ cm}^{-1}, & \nu_2 \text{ (symmetric S-O bend), } 669 \text{ cm}^{-1}, \\ \nu_3 \text{ (S-S stretch), } & 435 \text{ cm}^{-1}, \quad \nu_4 \text{ (asymmetric S-O stretch),} \\ & 1123 \text{ cm}^{-1}, \\ \nu_5 \text{ (asymmetric S-O bend), } 541 \text{ cm}^{-1}, & \nu_6 \text{ (-SO}_3 \text{ rocking), } 335 \text{ cm}^{-1} \end{array}$$

Miller and Wilkins<sup>271</sup> have reported the spectra of several thiosulphates. The band at  $\sim 670 \text{ cm}^{-1}$  is often broad and the maximum occurs over the range  $640-680 \text{ cm}^{-1}$ . The S-O stretching modes ( $\nu_1 = 950-1000 \text{ cm}^{-1}$ ,  $\nu_4 = 1100-1130 \text{ cm}^{-1}$ ) are, with exception of the ammonium compound, well defined. Buijs<sup>326</sup> has examined the spectra of thiosulphates on an ion-exchange resin, the spectra are essentially unchanged though new bands appear due to  $\text{S}_4\text{O}_6^{2-}$  ions formed by the facile atmospheric oxidation of thiosulphate under these conditions.

#### (iii) Other oxo-anions

Simon<sup>327</sup> has examined the Raman spectrum of the dithionite ion ( $\text{S}_2\text{O}_4^{2-}$ ) and reported S-O stretching modes at  $1070$  and  $998 \text{ cm}^{-1}$ . The pyrosulphite ion  $\text{S}_2\text{O}_5^{2-}$  has been studied by Simon *et al.*<sup>328</sup> who concluded that an SOS grouping was present and interpreted their infrared and Raman data on the basis of  $C_{2v}$  symmetry.



However, X-ray analysis shows the presence of an S-S bond in a structure of  $C_s$  symmetry Buijs<sup>326</sup> in a more recent examination of the infrared spectrum has reported five fundamentals in the S-O stretching region as expected on the basis of the required  $C_s$  symmetry. The assignment of the fundamental frequencies of the dithionate ion ( $S_2O_6^{2-}$ ) is subject to some controversy. Palmer<sup>268</sup> from a study of the Raman and infrared spectra of the sodium and potassium salts has assigned the S-O stretching frequencies, on the basis of  $D_{3d}$  symmetry, as follows

- $\nu_1$  (asymmetric S-O stretch), 1235-1240  $cm^{-1}$ ,
- $\nu_{10}$  (asymmetric S-O stretch), 1206-1216  $cm^{-1}$ ,
- $\nu_5$  (symmetric S-O stretch), 996-1000  $cm^{-1}$ ,
- $\nu_1$  (symmetric S-O stretch), 1092-1102  $cm^{-1}$

On the other hand, Buijs<sup>70,326</sup> has interpreted his infrared data, in conjunction with the Raman studies of Duval and Lecomte<sup>329</sup> to suggest that the fundamentals should be assigned as,  $\nu_7 = 994$  and  $998$   $cm^{-1}$ ,  $\nu_{10} = 1212$   $cm^{-1}$ ,  $\nu_5 = 1230$  and  $1243$   $cm^{-1}$ , and  $\nu_1 = 1200$   $cm^{-1}$ . Compounds containing  $S^{VI}$  have been found to give rise to symmetrical and asymmetrical stretching frequencies which vary linearly with one another (Fig 5 6 section 12 a) The assignments made by Palmer give rise to average values of,  $\nu_s SO = 1046$   $cm^{-1}$  and  $\nu_{as} SO = 1221$   $cm^{-1}$ , which fit this general relationship fairly well. The corresponding values from Buijs assignments are,  $\nu_s SO = 1237$   $cm^{-1}$  and  $\nu_{as} SO = 1068$   $cm^{-1}$ , which do not fit the straight line of Figure 6 The effect of site symmetry on the fundamental frequencies has been discussed by Buijs (loc. cit.)

Simon and Wagner<sup>269</sup> have studied the infrared and Raman spectra of the disulphate ion ( $S_2O_7^{2-}$ ) and have interpreted their data in terms of  $C_{2v}$  symmetry Symmetric S-O stretching modes occur in the infrared at  $\sim 1060$  and  $\sim 1110$   $cm^{-1}$ , the corresponding asymmetric modes being at  $1249-1267$  and  $1289-1295$   $cm^{-1}$  Similar frequencies are observed in the Raman spectra Bands at approx  $740$  and  $800$   $cm^{-1}$  were assigned to the symmetric and asymmetric SOS stretching modes, respectively, in agreement with the assignments of Dupuis and Viltange<sup>330</sup> Gillespie and Robinson<sup>331</sup>, however, have assigned frequencies of  $\sim 150$ ,  $\sim 300$  and  $\sim 800$   $cm^{-1}$  to the bend, symmetric stretch and asymmetric stretch, respectively, of the SOS group in molecules of the type  $X_n SOSX_n$  including  $S_2O_7^{2-}$  Further, these authors have shown that there exist linear relationships between the symmetric stretching and bending modes of the SOS group and the square root of the mass of the groups  $SX_n$  attached to the oxygen atom. For the disulphate ion SO bending modes occur at  $\sim 520$  (symmetric) and  $\sim 590$   $cm^{-1}$  (asymmetric).

The Raman and infrared spectra of several peroxodisulphates ( $S_2O_8^{2-}$ ) have been examined by Simon and Richter<sup>332</sup> who assigned a band at  $1267$   $cm^{-1}$  in both spectra to an S-O stretching vibration Since the  $S_2O_8^{2-}$  ion contains S(VI), its symmetric and asymmetric frequencies are expected to fit the linear relationship shown in Fig 5 6 If the  $1267$   $cm^{-1}$  band is assigned to the asymmetric mode then the band observed

at  $1088\text{ cm}^{-1}$  in the Raman, (not assigned by Simon and Richter) is in the region expected for the symmetric stretch.

The spectrum of the tetrathionate ion ( $\text{S}_4\text{O}_6^{2-}$ ) has been discussed in some detail<sup>326, 482</sup>. There are six fundamental S-O stretching modes and these occur in the regions  $1010\text{--}1050\text{ cm}^{-1}$  and  $1200\text{--}1250\text{ cm}^{-1}$ . As expected these frequencies are close to those observed for the  $\text{S}_2\text{O}_6^{2-}$  ion. Schmidt and Sand<sup>333</sup> have assigned bands in these same regions to the S-O vibrations of  $\text{K}_2\text{S}_2\text{O}_6$  and these authors<sup>334</sup> have shown that the infrared spectra of the ions  $\text{S}_n\text{O}_6^{2-}$ , where  $n = 3\text{--}6$ , are similar

(iv) *Complexes containing oxo-anions as ligands*

(1) *Sulphito-compounds* Compounds of the types  $\text{M}_2^I\text{M}^{II}(\text{SO}_3)_2$  and  $\text{M}^I\text{CuSO}_3$ , have simple spectra typical of the free ion and, therefore, are double salts and not complexes<sup>273</sup>. When functioning as a unidentate ligand the sulphite group may bond through either sulphur or oxygen. The  $\text{C}_{3v}$  symmetry of the free ion will be essentially undisturbed if S-bonding occurs and the infrared spectra of complexes<sup>273, 335, 336</sup> of  $\text{Co}^{III}$ ,  $\text{Rh}^{III}$ ,  $\text{Ir}^{III}$ ,  $\text{Pd}^{II}$ ,  $\text{Pt}^{II}$  and  $\text{Hg}^{II}$  are in accordance with this suggestion. Bonding through oxygen lowers the symmetry to  $\text{C}_s$ , causing more profound changes in the spectrum,  $\text{Ti}_2[\text{Cu}(\text{SO}_3)_2]$  is the only compound for which O-bonding is reported<sup>273</sup>.

When occupying two coordination positions the sulphito-group may be bidentate or bridging. As is the case with sulphato-compounds it seems doubtful<sup>273</sup> if infrared data can distinguish between the two possibilities.

Baldwin<sup>335</sup> has interpreted the infrared spectrum of  $[\text{Coen}_2\text{SO}_3]\text{Cl}$  to show that the sulphito group is bidentate. Newman and Powell<sup>273</sup> found that the spectrum of  $[\text{Coen}_2\text{SO}_3]\text{Cl}$  is similar to the spectra of  $\text{K}_2[\text{Pt}(\text{SO}_3)_2] \cdot 2\text{H}_2\text{O}$ ,  $\text{Na}_3[\text{Co}(\text{SO}_3)_3] \cdot 4\text{H}_2\text{O}$  and  $\text{K}_3[\text{Rh}(\text{SO}_3)_3] \cdot 2\text{H}_2\text{O}$ , they concluded that infrared spectral data alone cannot distinguish between the two possible structures. These latter authors discussed the infrared data in some detail and commented upon Baldwin's<sup>335</sup> interpretation of her data. On the other hand, Babaeva and Kharitonov<sup>337</sup> have suggested that the infrared spectra support the assignment of structures involving bridging sulphito-groups to  $[\text{Co}(\text{SO}_3)_3]^{3-}$  and  $[\text{Rh}(\text{SO}_3)_3]^{3-}$ . The spectrum<sup>273</sup> of  $\text{K}_2[\text{Pd}(\text{SO}_3)_2]$  indicates that its structure may differ from that previously suggested<sup>338</sup>.

(2) *Sulphato-compounds.* Nakamoto *et al.*<sup>339</sup> have discussed the spectra of both unidentate and bidentate sulphato-groups. When the group functions as a unidentate ligand *e.g.* in  $[\text{Co}(\text{NH}_3)_5\text{SO}_4]\text{X}$  compounds<sup>339, 340</sup>, the symmetry is lowered to  $\text{C}_{3v}$ , whilst in the case that bridging occurs, *e.g.*,

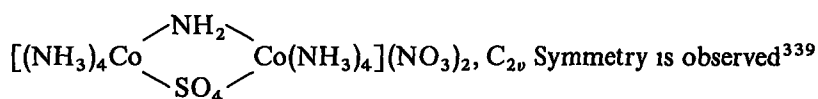

Barracough and Tobe<sup>341</sup> from a study of the spectrum of  $[\text{Coen}_2\text{SO}_4]\text{Br}$  have con-

cluded that it is not possible to distinguish between bridging and chelating sulphato-groups using infrared data only. On the other hand, McWhinnie<sup>307</sup> has suggested that a band at  $\sim 1220 \text{ cm}^{-1}$  may be used to differentiate between the two possibilities. The spectra of some protactinium di- and tri-sulphato complexes have been reported and discussed<sup>342</sup>. Both uni- and bidentate sulphato groups may be present and since the various possibilities could not be differentiated the coordination of the protactinium remains uncertain. Baldwin<sup>343</sup> has discussed the spectra of various complex sulphates and of compounds of the types,  $\text{Y}_2\text{SO}_4 \cdot \text{MSO}_4 \cdot 6 \text{H}_2\text{O}$  and  $\text{Y}_2\text{SO}_4 \cdot \text{X}_2(\text{SO}_4)_3 \cdot 24 \text{H}_2\text{O}$ , i.e. Tutton salts and alums. It appears that these hydrated compounds may give rise to quite complex spectra and Baldwin concludes that whilst a simple spectrum indicates an undistorted sulphato-group it does not necessarily follow that a complicated band structure shows conclusively coordination to a metal or even significant deviation from a tetrahedral structure.

Livingstone<sup>121</sup> has recently reviewed the metal complexes of ligands containing sulphur as a donor atom; sulphito and thiosulphato complexes were also discussed by this author.

(c) *Thionyl (-SO-) compounds*

Table 5.12 shows the S-O stretching frequencies observed in various thionyl compounds. With the sulphoxides,  $\text{R}_2\text{SO}$ , considerable molecular aggregation occurs in the liquid phase with the result<sup>36,344,345</sup> that

$$\nu_{\text{SO}(\text{liquid})} < \nu_{\text{SO}(\text{solution})} < \nu_{\text{SO}(\text{vapour})}$$

TABLE 5.12

S-O STRETCHING FREQUENCIES IN THIONYL COMPOUNDS

Type of compound	$\nu_{\text{SO}} (\text{cm}^{-1})$	$n^*$
simple sulphoxides, $\text{R}_2\text{SO}$ , (R = aryl, alkyl, alkenyl)	1010-1070 <sup>a</sup>	
cyclic sulphoxides, $(\text{CH}_2)_n\text{SO}$	1039-1055, 1192 <sup>b</sup>	
$(\text{CH}_2\text{O})_2\text{SO}$	1220	
disulphoxides	1036-1088	
dimethyl sulphoxide-metal complexes	978-1037 <sup>c</sup>	
tetramethylene sulphoxide-metal complexes	950	
S-alkylsulphoxonium compounds	1210-1240	
O-methylsulphoxonium nitrate	925-1050	
$\text{SOX}_2$ (X = F, Cl, Br)	X = F, 1308, X = Cl, 1251 <sup>d</sup> X = Br, 1121	}
$\text{SOF}_4$	1379	

<sup>a</sup> see text for variation of  $\nu_{\text{SO}}$

<sup>b</sup> when  $n = 4$ ,  $\nu_{\text{SO}} = 1192 \text{ cm}^{-1}$ , this value is anomalously high

A similar situation arises with the cyclic ketones<sup>36</sup>

<sup>c</sup> except Pd(II) and Pt(II) complexes, see text

<sup>d</sup> see Table 5.20 section 15

and because of the considerable solute-solvent interactions that can arise with these compounds the observed solution frequency is markedly solvent dependant<sup>346</sup> The range quoted in Table 5.12 covers the frequencies observed in CCl<sub>4</sub> and CS<sub>2</sub> solutions. In contrast to the sulphones it is not possible to differentiate between compounds having R = aryl and those having R = alkyl. Barnard, Fabian and Koch<sup>344</sup> have suggested that the constancy of  $\nu_{\text{SO}}$  at  $\sim 1055 \text{ cm}^{-1}$  for several sulphoxides arises from the fact that negligible coupling occurs between the S-O vibration and the lower frequency C-S vibration, and Price and Gillis<sup>347</sup> report that negligible conjugation occurs between C=C and S=O bonds in alkyl-alkenyl sulphoxides. Coupling between the S-O stretching and CH<sub>3</sub> rocking modes in dimethyl sulphoxide is, however, well substantiated<sup>348,349</sup> and leads to some difficulty in the assignment of  $\nu_{\text{SO}}$  in dimethyl sulphoxide-metal complexes. Lappert and Smith<sup>350</sup>, and Cotton Francies and Horrocks<sup>345</sup> have assigned a band at 900-950  $\text{cm}^{-1}$  to the S-O stretching vibration in a wide variety of dimethyl sulphoxide complexes and have concluded that since in these complexes  $\nu_{\text{SO}}$  occurs at lower frequencies than in the free ligand, the ligand is bonded through the oxygen atom of the S-O bond. Complexes of Pd<sup>II</sup> and Pt<sup>II</sup> are exceptions to this general rule<sup>345,351,352</sup>, as are complexes of the type C<sub>5</sub>H<sub>5</sub>Mn(CO)<sub>2</sub>D, where D may be various sulphoxides<sup>353</sup>, in that the ligands are bound through the sulphur atom with the result that  $\nu_{\text{SO}}$  is at a higher frequency than in the free ligand. Drago and Meek<sup>349,354</sup> assign a band at  $\sim 1000 \text{ cm}^{-1}$  to the S-O stretch in the "normal" O-bonded complexes and suggest that the 900-950  $\text{cm}^{-1}$  band is due to a CH<sub>3</sub> rocking mode since its frequency remains fairly constant in many complexes, whilst that of the band at  $\sim 1000 \text{ cm}^{-1}$  varies with the metal ion. These authors suggest that considerable coupling occurs between these two modes so that when  $\nu_{\text{SO}}$  is less than  $\sim 990 \text{ cm}^{-1}$ , e.g., in Cu<sup>II</sup> complexes, the assignment of " $\nu_{\text{SO}}$ " is very difficult. Since the extent to which the S-O vibration is involved in coupling will vary with the sulphoxide it is dangerous to use the shift in  $\nu_{\text{SO}}$  which occurs on complex formation as a measure of the variation of bond strengths for various ligands<sup>351</sup>. The infrared spectra of sulphoxide complexes with I<sub>2</sub> and ICN indicate that in these compounds also the bonding is through the oxygen atom<sup>40</sup>.

(d) *Structural data · Bond lengths and bond angles*

(i) *Introduction*

For the S-O single bond Pauling's covalent radii<sup>168</sup> give a value of 1.70 Å, and the Schomaker-Stevenson<sup>335</sup> rule gives 1.69 Å. In the case of double bonds the corresponding values are 1.49 Å and 1.47 Å respectively. To date no compound is known in which the S-O bond is as long as the predicted value for the single bond. The longest reported bonds<sup>356-358</sup> are 1.66 Å in SF<sub>5</sub>O OSF<sub>5</sub>; 1.64 Å in SF<sub>5</sub>OF, and 1.64 Å in HS<sub>2</sub>O<sub>7</sub>. The value of 1.72 Å in (NO<sub>2</sub>)<sub>3</sub>S<sub>3</sub>O<sub>10</sub> is not considered reliable<sup>359</sup>. In these compounds the 3d-orbitals normally used for double bonding with oxygen<sup>360,361</sup> are largely utilised in forming single bonds to other oxygen atoms. However, there is

some evidence<sup>361</sup> that even for these long bonds some  $d_{\pi-p_{\pi}}$  overlap occurs so that they may be expected to be somewhat shorter than a true single bond. The situation with respect to double bonds is less satisfactory. The shortest observed bond lengths\* are 1.39 Å in  $\text{SO}_2(\text{NH}_2)_2$ <sup>171</sup>, 1.405 Å in  $\text{SO}_2\text{F}_2$ ,<sup>424</sup> 1.412 Å in  $\text{SOF}_2$ <sup>430</sup>, and 1.40 Å in  $\text{S}_3\text{O}_9$ <sup>387</sup>, all of which are appreciably shorter than the predicted double bond value. Gillespie and Robinson<sup>362</sup> comment that the double bond radii may well be incorrect and take the value of 1.40 Å as that of a true SO double bond. Abrahams<sup>363</sup> has used Moffitt's bond order assignments<sup>360</sup> to predict a double bond length of 1.425 Å, and since the observed bond lengths in many compounds expected to contain S=O bonds are reasonably constant at about 1.44 Å this assignment has found fairly wide acceptance. Cruickshank<sup>361</sup> has considered the S-O bond from a theoretical standpoint and proposed a linear relationship between bond lengths and bond order. However, the bond orders calculated by this author lead to an unsatisfactorily short length of about 1.30 Å for the double bond.

(ii) *Compounds derived from the  $\text{SO}_4^{2-}$  tetrahedra*

Table 5.13 lists most of the important published data. Further data are available for some types of compounds, e.g., sulphates, but most of this is referred to in the literature quoted. For most simple hydrated and anhydrous sulphates the reported S-O distances fall within the range 1.47–1.53 Å, though recent high resolution studies<sup>364–368</sup> on several hydrates all report average S-O distances in the range  $1.473 \pm 0.003$  Å. In many cases the tetrahedral symmetry of the sulphate group is only slightly distorted<sup>367,369,370</sup>, though in a few cases<sup>371</sup>, e.g.  $\text{CdSO}_4$  and  $\text{HgSO}_4$ , the distortion is more marked. These two compounds are also unusual in that the metal ions are surrounded by a very distorted tetrahedron of oxygen atoms, whilst for all other  $\text{M}^{\text{II}}\text{SO}_4$  compounds only the very small beryllium ion has a tetrahedral coordination, and Mg, Mn, Fe, Co, Ni, Cu, and Zn, all of which have an ionic radius smaller than cadmium or mercury, are octahedrally coordinated. The high temperature form of  $\text{CdSO}_4$  has the expected octahedral coordination<sup>372</sup>.

Ananthanarayanan<sup>287</sup> has studied the effect of crystal forces on S-O distances and O-S-O angles in anhydrous sulphates by Raman spectroscopy. Atojie and Rundle<sup>373</sup> from a neutron diffraction study of  $\text{CaSO}_4 \cdot \text{H}_2\text{O}$  have shown the deviations of the O-S-O angles from the tetrahedral angle to be insignificant, whereas both the Raman<sup>374</sup> and infrared<sup>375</sup> spectra have been interpreted to suggest that the sulphate group symmetry is distorted. Atojie and Rundle conclude that spectroscopic methods are apparently the more sensitive in detecting the effects of crystalline field effects. Larsen<sup>367</sup> has summarised the available high resolution data for various hydrated sulphates, and has shown that these fall into two classes, having average corrected S-O distances of 1.480 Å and 1.486 Å respectively. In the compounds having the

\* The reported value of 1.38 Å in  $(\text{NO}_2)_2\text{S}_3\text{O}_{10}$  is considered unreliable<sup>359</sup>, the value of 1.37 Å in  $\text{S}_3\text{N}_2\text{O}_2$ , the shortest SO bond length reported<sup>189</sup>, must be used with caution in the absence of a confirmatory analysis.

TABLE 5 13

BOND LENGTHS AND ANGLES IN SOME S O COMPOUNDS

Compound	$r_{s-o}$ (Å)	$\widehat{XSO}$	$\widehat{OSO}$	References
SO	1.4933			379
S <sub>2</sub> O	1.46 ± 0.01	118.0 ± 0.5°		380
SO <sub>2</sub>	1.43 ± 0.01		119.5 ± 1.5°	381, 382
	1.4321 ± 0.0005		119.0 ± 0.5°	383, 384
SO <sub>3</sub>	1.43 ± 0.02		120 ± 2°	386
ice-like (SO <sub>3</sub> ) <sub>3</sub>	1.40 ± 0.05		122° (O=S=O)	387
	1.60 ± 0.05		100° (O-S-O)	
asbestos, (SO <sub>3</sub> ) <sub>n</sub>	1.59 ± 0.04		128°	388
	1.63 ± 0.04		102°	
LiSO <sub>4</sub> H <sub>2</sub> O	1.47		109.5 ± 0.1	367
ZnSO <sub>4</sub>	1.48		109.5°	389
HgSO <sub>4</sub>	1.50		107.6°, 116.5°	371
CuSO <sub>4</sub>	1.51 ± 0.03		109.5°	389, 369
CdSO <sub>4</sub>	1.53		103.0, 115.8°	371
VOSO <sub>4</sub>	1.43			390
Li(N <sub>2</sub> H <sub>5</sub> )SO <sub>4</sub>	1.43		109.8°	
	1.56			391
H <sub>2</sub> SO <sub>4</sub>	1.43		104°, 117°	
	1.54			392, 393
NaHSO <sub>4</sub>	1.613 ± 0.013		101.25 ± 1.0°	
	1.450 ± 0.013		112.75 ± 1.0°	
KHSO <sub>4</sub>	1.56 ± 0.015		107°, 112°	395
	1.56 ± 0.015			
H <sub>2</sub> NSO <sub>3</sub> H	1.439 ± 0.022	103.5°	115.1°	190, 396
H <sub>2</sub> NSO <sub>3</sub> K	1.42 ± 0.03	107.5 ± 0.5°	111.5 ± 0.5°	191, 397
K <sub>2</sub> NH(SO <sub>3</sub> ) <sub>2</sub>	1.447 ± 0.005		112.75 ± 1.0°	192
K <sub>2</sub> CH <sub>2</sub> (SO <sub>3</sub> ) <sub>2</sub>	1.461 ± 0.005	107.3 ± 0.5°	113.1 ± 0.7°	376
MgS <sub>2</sub> O <sub>6</sub> ·6H <sub>2</sub> O	1.48 ± 0.02	108.1 ± 0.8°	111.0 ± 1.1°	398, 399
Na <sub>2</sub> S <sub>2</sub> O <sub>4</sub>	1.51 ± 0.02	98.7°	108.2°	400
K <sub>2</sub> S <sub>2</sub> O <sub>5</sub>	1.50 ± 0.01 (-SO <sub>2</sub> <sup>-</sup> )	100.5°	100.3° (-SO <sub>2</sub> <sup>-</sup> )	377
	1.43 ± 0.01, (-SO <sub>3</sub> <sup>-</sup> )			
	1.47 ± 0.01, (-SO <sub>3</sub> <sup>-</sup> )	106.6°	111.9° (-SO <sub>3</sub> <sup>-</sup> )	
K <sub>2</sub> S <sub>2</sub> O <sub>6</sub>	1.43 ± 0.05	105 ± 1°		401, 402,
				403
NaK <sub>5</sub> Cl <sub>2</sub> (S <sub>2</sub> O <sub>6</sub> ) <sub>2</sub>	1.48 ± 0.05			404
(NO <sub>2</sub> ) <sub>2</sub> S <sub>3</sub> O <sub>10</sub>	1.38, 1.42, 1.54		101°, 122°	359
	1.72			
NO <sub>2</sub> HS <sub>2</sub> O <sub>7</sub>	1.64 ± 0.03 (S-O(H))		133° (OSO(H))	358
	1.47 ± 0.03		107° - 118°	
Na <sub>2</sub> S <sub>4</sub> O <sub>6</sub> ·2H <sub>2</sub> O	1.46 ± 0.02	107.8 ± 1.0°	113.6 ± 1.4°	405
BaS <sub>4</sub> O <sub>6</sub> ·2H <sub>2</sub> O	1.43 ± 0.04	105°	113°	406, 407
(NH <sub>4</sub> ) <sub>2</sub> SO <sub>3</sub> ·N <sub>2</sub> O <sub>2</sub>	1.44 ± 0.01	103.9°	115.1°	169, 408
Ni(H <sub>2</sub> O) <sub>6</sub> SO <sub>3</sub>	1.45 ± 0.03		95.4°	409, 410
BaSe(S <sub>2</sub> O <sub>3</sub> ) <sub>2</sub>	1.40	106°	113°	411
(NH <sub>4</sub> ) <sub>2</sub> Te(S <sub>2</sub> O <sub>3</sub> ) <sub>2</sub>	1.43	106°	112°	412
(C <sub>6</sub> H <sub>5</sub> ) <sub>2</sub> SO <sub>2</sub> ·2Se	1.43			413
(CH <sub>3</sub> SO <sub>2</sub> ) <sub>2</sub> Te	1.43			414
[Ru(II)(NH <sub>3</sub> ) <sub>4</sub> SO <sub>2</sub> Cl]Cl	1.428 ± 0.010		113.8 ± 0.6°	415
(C <sub>6</sub> H <sub>5</sub> ) <sub>2</sub> SOSbCl <sub>3</sub>	1.53			416
(CH <sub>3</sub> ) <sub>2</sub> SOBF <sub>3</sub>	1.52			416
[(CH <sub>3</sub> ) <sub>2</sub> SO] <sub>2</sub> SnCl <sub>4</sub>	1.51, 1.54			416
S <sub>3</sub> N <sub>2</sub> O <sub>2</sub>	1.37	115.3°		189
(NSOCl) <sub>3</sub>	1.407 ± 0.007	(ClSO)107.9° } (NSO)111.9° }		181

longer S-O distance (1.486 Å), the sulphate group has only hydrogen atoms as nearest neighbours whilst in the other compounds at least two of the sulphate oxygen atoms have cations as nearest neighbours. The individual S-O distances within the sulphate group reflect the slight distortions caused by the cations or hydrogen atoms. Ions such as  $S_2O_6^{2-}$ ,  $S_2O_7^{2-}$ ,  $S_3O_{10}^{2-}$ ,  $HN(SO_3)_2^-$ , and  $[SO_3N_2O_2]^{2-}$  and molecules such as  $SO_3^-NH_3^+$  and  $(SO_3)_n$  may be regarded as derived from the tetrahedral  $SO_4^{2-}$  group. Cruickshank<sup>361</sup> has discussed the bonding in some of these compounds and has suggested that in the  $SO_4^{2-}$  ion two strong  $\pi$ -bonding molecular orbitals are formed by overlap of the  $3d_{x^2-y^2}$  and  $3d_{z^2}$  of the sulphur and the appropriate  $2p_\pi$  and  $2p_\pi$  orbitals of oxygen. By an extension of this concept the structures of many sulphur-containing anions are explained and the observed bond lengths correlated with their  $\pi$ -bond order. Cruickshank suggests that the use of  $3d$ -orbitals for  $\pi$ -bonding is of potential importance whenever sulphur is tetrahedrally coordinated and that the ability of doubly linked oxygen and triply linked nitrogen to share in these  $\pi$ -bonds is widespread. Cruickshank's predicted bond lengths for  $K_2(CH_2(SO_3)_2)$  have been essentially confirmed by Truter<sup>376</sup> which lends support to this theory. On the other hand, Lindquist and Mörtzell<sup>377</sup> have used the observed O-S-O bond angles in  $S_2O_4^{2-}$ ,  $S_2O_5^{2-}$  and  $S_2O_6^{2-}$  ions to determine the hybrid orbitals used by sulphur in these compounds, assuming that these are orthogonal combinations of  $3s$ - and  $3p$ -orbitals only. The results indicate that this assumption is essentially correct for the thionate group and that the bond lengths are principally determined by the  $s$ -character of the hybrid orbitals forming the  $\sigma$ -bonds. The possibility that  $d$ -orbitals are used in the thionite group was not eliminated. Truter<sup>378</sup> has discussed the structures of various S(II), S(IV), and S(VI) compounds and concludes that there is as yet no theory which accounts satisfactorily for the bond lengths in all the oxo compounds of sulphur. She concludes that theories that imply a gradation from S(II) to S(VI) do not explain the essentially anomalous character of S(IV) which forms the longest single bonds and has the smallest bond angles. A possible explanation is that hybridisation is essentially the same ( $sp^3$ ) in S(II) and S(VI) but is different in S(IV), the small angles around S(IV) indicating a tendency to pure  $p$ -bonds with a predominantly  $s$  lone pair. The  $p$ -bonds would result in a larger radius and a smaller electronegativity for S(IV).

It would seem that many factors combine to determine bond lengths. These factors which are often interdependent include the oxidation state of sulphur, its hybridisation, the electronegativities of all the atoms and the existence of  $\pi$ -bonding.

### (iii) Sulphoxides and sulphones

The molecular dimensions of these groups illustrated in Tables 5.14 and 5.15. Little new data has appeared since these groupings were reviewed by Abrahams<sup>363</sup>. In the case of the sulphoxides the three sulphur bonds form a shallow pyramid; the XSO angle has a particularly constant value at  $106^\circ$ - $108^\circ$  and the XSX angle varies from  $93^\circ$  to  $114^\circ$ . The tetrahedral structure of the sulphate, and related groups, is

Nickless Ch 5-37 1st proof

TABLE 5 14

## MOLECULAR DIMENSIONS IN THE SULPHOXIDE GROUP

Molecule	$\widehat{X-S-O}$ ( $^{\circ}$ )	$\widehat{X-S-X}$ ( $^{\circ}$ )	$r_{S-O}$ (Å)	References
F <sub>2</sub> SO	106.8 ± 0.1	92.8 ± 0.1	1.412 ± 0.001	430
Cl <sub>2</sub> SO	106.0 ± 1.0	114.0 ± 2.0 <sup>a</sup>	1.45 ± 0.02	425
Br <sub>2</sub> SO	108.0 ± 2.0	96.0 ± 2.0	1.45 (assumed)	429
(CH <sub>3</sub> ) <sub>2</sub> SO	107.0 ± 5.0	100.0 ± 5.0	1.47 ± 0.03	431
(C <sub>6</sub> H <sub>5</sub> ) <sub>2</sub> SO	106.2 ± 0.7	97.3 ± 1.0	1.473 ± 0.015	432
CH <sub>3</sub> SO CH <sub>2</sub> CH(NH <sub>2</sub> ) C(O)OH	107.5 ± 0.7	96.7 ± 1.0	1.488 ± 0.012	433

<sup>a</sup> Angles smaller than 106° were not used in the models tried

TABLE 5 15

## MOLECULAR DIMENSIONS IN THE SULPHONE GROUP

Molecule	$\widehat{X-S-O}$ ( $^{\circ}$ )	$\widehat{X-S-X}$ ( $^{\circ}$ )	$\widehat{O-S-O}$ ( $^{\circ}$ )	$r_{S-O}$ (Å)	References
F <sub>2</sub> SO <sub>2</sub>		100.0 ± 8.0	130.0 ± 10	1.43 ± 0.02	225
		96.1 ± 0.2	124.0 ± 0.2	1.405 ± 0.003	424
Cl <sub>2</sub> SO <sub>2</sub>	106.5 ± 2.0	111.2 ± 2.0	119.8 ± 5.0	1.43 ± 0.02	425
(CH <sub>3</sub> ) <sub>2</sub> SO <sub>2</sub>	105.3 ± 3.0	115.0 ± 15	125.0 ± 15	1.43 ± 0.02	426
C <sub>6</sub> H <sub>5</sub> SO <sub>2</sub> CH <sub>3</sub>	107.0 (av)	112.0	120.0	1.455 ± 0.015	427
[(CH <sub>3</sub> ) <sub>2</sub> N] <sub>2</sub> SO <sub>2</sub>		112.6	119.7	1.499	428
(H <sub>2</sub> N) <sub>2</sub> SO <sub>2</sub>	106.2 ± 0.5	112.1 ± 0.7	119.4 ± 0.8	1.391 ± 0.008	171

essentially maintained in the sulphones. Comparison of the data in Tables 5 14 and 5 15 shows the geometry of the two groupings to be similar. Thus, the XSO angle in the sulphones has nearly the same constant angle, 107°, as in the sulphoxides and the XSX angles in related pairs of compounds are also similar, e.g., the FSF angles in SOF<sub>2</sub> and SO<sub>2</sub>F<sub>2</sub> are 92.8° and 96.1° respectively. The OSO angle in the sulphone group is invariably the largest sulphur bond angle in a given molecule, and is always greater than the tetrahedral value. This is because electron repulsions due to multiple bonds are stronger than repulsions due to single bonds<sup>417</sup>. The structural similarity between sulphoxides and sulphones is particularly well established in the case of the diphenyl derivatives<sup>418,419</sup>. Diphenyl sulphoxide dissolves in diphenyl sulphone to form a continuous series of solid solutions and it has been suggested that the sulphur lone pair of diphenyl sulphoxide occupies the same direction and effective volume as one of the sulphur oxygen bonds in diphenyl sulphone. Three other organic sulphones<sup>420-422</sup> and one cyclic compound<sup>426</sup> are reported and were discussed by Abrahams. A theoretical treatment of the bonding in both groupings has been given by Moffitt<sup>360</sup>.

## (e) Correlations between stretching frequency and molecular parameters

The nature of the sulphur-oxygen bond in sulphonyl (XYSO<sub>2</sub>) and thionyl (XYSO) Nickless Ch 5-38 1st proof



compounds has been discussed by Gillespie and Robinson<sup>362</sup> These authors consider that the two possible extreme forms of the S-O bond may be represented as (I) and (II)



Structure (I) represents a situation in which the bonding electrons are equally shared and arises when the other atoms attached to sulphur have electronegativities sufficiently great to raise the effective electronegativity of sulphur to that of oxygen This situation is approached in  $\text{SO}_2\text{F}_2$  and  $\text{SOF}_4$  With decreasing electronegativity of the attached groups the bond becomes polar and in the limit the  $\pi$ -bond electron pair resides essentially on the oxygen atom and structure (II) results. The observed frequencies for sulphuryl compounds and S(VI) containing anions are in agreement with these suggestions. The highest frequencies ( $1270$  and  $1502 \text{ cm}^{-1}$ ) are found for  $\text{SO}_2\text{F}_2$  and the lowest ( $981$  and  $1104 \text{ cm}^{-1}$ ) are those of the sulphate ion. Similarly, for the sulphoxides  $\text{X}_2\text{SO}$  the highest frequency ( $1308 \text{ cm}^{-1}$ ) is found for  $\text{SOF}_2$  For  $\text{SOF}_4$  the frequency is even higher ( $1379 \text{ cm}^{-1}$ ) than in  $\text{SOF}_2$  which is consistent with the presence of two additional highly electronegative ligands. Increasing electronegativity of the groups X and Y should increase the order of the SO bond and since the lengths of the SO bonds may be assumed to be related to their bond order a correlation is to be expected between stretching frequency and bond lengths This relationship has been verified by Gillespie and Robinson and is illustrated in Fig 5 8 In the case of  $-\text{SO}_2-$  compounds the appropriate stretching frequency was calculated<sup>434</sup> from the equation

$$\nu_{\text{SO}} = \frac{1}{x} [\nu_s \text{SO} + (x-1) \nu_{\text{as}} \text{SO}] \quad (1)$$

where  $(x-1)$  is the degeneracy of the asymmetric vibration The scatter of the points in Fig 5 8 is, in general, not greater than  $\pm 0.02 \text{ \AA}$  which is of the order of the experimental error of most of the bond length determinations

For several compounds not considered by Gillespie and Robinson both bond lengths and stretching frequencies are now available so that values of the bond length predicted from Fig 5 8 may be compared with the experimental values The appropriate data is given in Table 5 16.

For compounds having bond lengths in the range  $1.45$ – $1.48 \text{ \AA}$  agreement between predicted and observed values is particularly good The results for compounds containing short ( $\sim 1.40 \text{ \AA}$ ) and long ( $\sim 1.55 \text{ \AA}$ ) bonds are rather less satisfactory, the predicted values deviating by  $\pm 0.03 \text{ \AA}$  from the observed value Further, the bond length in the sulphite ion is of interest Gillespie and Robinson<sup>362</sup> predicted a value of  $1.65 \text{ \AA}$  and commented that the value ( $1.39 \text{ \AA}$ ) reported by Zachariasen and Buckley<sup>440</sup> seemed in error Using the values  $\nu_s \text{SO} = 970 \text{ cm}^{-1}$  and  $\nu_{\text{as}} \text{SO} = 930 \text{ cm}^{-1}$  (Table 5 9) the predicted value is  $1.55 \text{ \AA}$ . More recent bond lengths have been reported by

TABLE 5 16

SOME PREDICTED AND OBSERVED VALUES OF SULPHUR-OXYGEN BOND LENGTH ( $r_{S-O}$ )

Compound	$\nu_{S-O}$ ( $\text{cm}^{-1}$ ) (calc) <sup>a</sup>	$r_{S-O}$ Å (calc) <sup>b</sup>	$r_{S-O}$ Å (obs) <sup>c</sup>
$S_2O$	1165 (435)	1.46	1.47 (380)
$H_2NSO_3H$	1180 (436)	1.45	1.48 (438)
$S_2O_3^{2-}$	1080 (267)	1.48	1.44 (396)
$SOBr_2$	1121 (437)	1.47	1.48 (439)
$SO_2(NH_2)_2$	1254 (150)	1.43	1.45 (429)
$(Me_2SO)_2SnCl_4$	920, 905 (350)	1.56, 1.57	1.39 (171)
$(Me_2SO)BF_3$	938 (350)	1.55	1.40 (361)
			1.54 (416)
			1.52 (416)

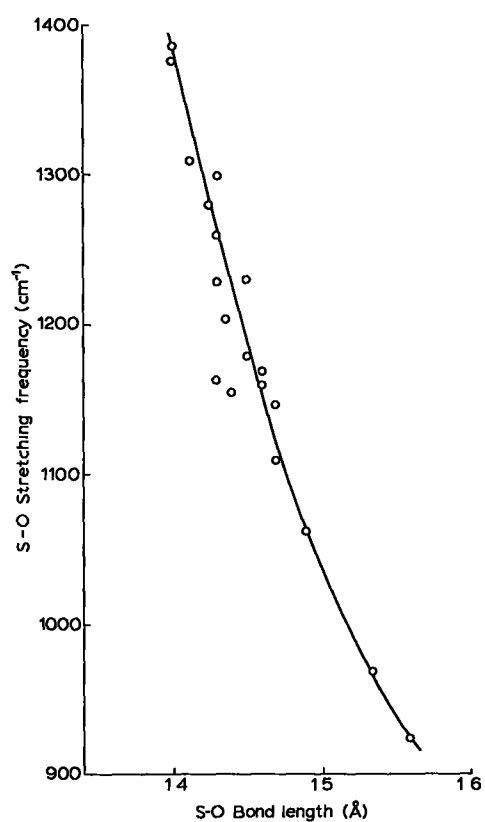
<sup>a</sup> calculated from equation 1, page<sup>b</sup> predicted from Fig 5 8<sup>c</sup> observed valueFig 5 8 Correlation of S-O stretching frequencies with bond length<sup>a</sup>  
a, from R J Gillespie and E A Robinson<sup>162</sup>

Nickless Ch 5 1 1st proof

Grand-Jean, Weiss and Kern<sup>410</sup> (1.45 Å) and Kierkegaard and Nyberg<sup>441</sup> (1.51 Å). Only the latter value is in even approximate agreement with the predicted value. Since the values of  $\nu_{as}SO$  and  $\nu_sSO$  for the sulphite ion do not fit the linear relationship shown in Fig 5.6, it is inadvisable to use the  $\nu_{SO}-r_{SO}$  plot for predicting  $r_{SO}$  values for S(IV) species which contain sulphur bonded to more than one oxygen atom.

Gillespie and Robinson<sup>362</sup> have also demonstrated a linear relationship between stretching frequency and OSO angle in  $-SO_2-$  compounds, though the correlation is not too well established since relatively little data was available. These authors have also discussed the problem of defining the bond order of sulphur-oxygen bonds and have suggested that there exists a linear relationship between the force constant and the bond order, and a non-linear relationship between the bond length and the bond order. That the bond order-bond length relationship for C-C bonds is also non-linear is thought to support the latter suggestion. On the other hand Cruickshank<sup>361</sup> has suggested that the bond order-bond length relationship for S-O compounds is rectilinear.

### (f) Deformation frequencies

The deformation frequencies of the oxo-anions have been mentioned in section 12 b. For sulphur dioxide the single symmetrical bending mode occurs<sup>442,443</sup> at  $520-530\text{ cm}^{-1}$ , and for the trioxide the symmetrical and asymmetrical bending modes occur at  $\sim 495$  and  $\sim 530\text{ cm}^{-1}$ , respectively<sup>444-446</sup>. The  $\gamma$  and  $\beta$  forms of  $(SO_3)_n$  have asymmetric bending modes at  $\sim 530$  and  $\sim 566\text{ cm}^{-1}$  respectively<sup>452</sup>. Sulphuryl compounds  $SO_2X_2$  and  $SO_2XY$  give rise to an  $SO_2$  scissoring bend and an  $SO_2$  rocking vibration, the values reported for a series of compounds<sup>12,150,447,448</sup> fall in the ranges  $520-610$  and  $530-620\text{ cm}^{-1}$ , respectively. Fearheller and Katon<sup>449</sup> from a study of several sulphones concluded that of the four  $SO_2$  bending vibrations only the  $SO_2$  scissoring ( $545-610\text{ cm}^{-1}$ ) and wagging ( $495-525\text{ cm}^{-1}$ ) are sufficiently localised to be of value as group frequencies. Bands in the region  $500-570\text{ cm}^{-1}$  have been assigned to bending modes in the alkali methyl sulphonates<sup>450</sup> and methyl sulphonic acid and its anhydride<sup>451</sup>. For sulphamic acid<sup>138</sup> the symmetric and asymmetric bending modes occur at  $640$  and  $511\text{ cm}^{-1}$  respectively, and in sulphamates<sup>138</sup> bands at  $520-560\text{ cm}^{-1}$  are assigned to  $SO_3$  deformations.

## 13. Sulphur

Stretching frequencies and structural data for S-S bonds are given in Table 5.17. X-ray analysis of rhombic sulphur<sup>453</sup> has shown the molecule to be a crown shaped  $S_8$  ring (point group  $D_{4d}$ ). All Raman lines are due to internal vibrations, since they are all present in solution<sup>455</sup>. From the Raman spectra of the solid<sup>454</sup> the strongly polarised lines at  $470$  and  $216\text{ cm}^{-1}$  can be assigned to  $\nu_1$  and  $\nu_2$  respectively. Of the

three allowed infrared active fundamentals ( $\nu_4$ ,  $\nu_5$  and  $\nu_6$ ),  $\nu_5$  is assigned at  $465 \text{ cm}^{-1}$  since it is a stretching mode, and hence at a higher frequency than  $\nu_4$  and  $\nu_6$  which are bending modes. The observed Raman shifts are in close agreement with the calculated values<sup>456,461</sup>. The far infrared spectra of  $S_8$  in  $CS_2$  solution and in discs have been discussed in a preliminary communication<sup>460</sup>. Sulphur chains consisting of  $S_2$ ,  $S_6$ , and  $S_n$  have been studied spectroscopically and by electron diffraction and the structural parameters determined<sup>457-459</sup>.

Molecules of the type  $XS_2S$  are generally assumed to be non-planar as found for  $S_2Cl_2$  ( $C_2$  symmetry and similar to  $H_2O_2$ ). Electron diffraction measurements<sup>573</sup> and vibrational spectra<sup>461</sup> of  $S_2Cl_2$  are consistent with such a model and exclude the planar arrangements trans ( $C_{2h}$ ) and cis ( $C_{2v}$ ). The infrared frequencies reported by

TABLE 517

STRETCHING FREQUENCIES AND STRUCTURAL DATA FOR S-S BONDS

Compound type	$\nu_{S-S}$ ( $\text{cm}^{-1}$ )	$r_{S-S}$ (Å)	$\widehat{SSX}$ ( $^\circ$ )	References
$S_8$	<sup>a</sup>	2.060	108.0	473-475, 541
$S_2$	668	1.887		457, 458, 476
$S_n$		2.1	100	459
$S_2H_2$	509R, 501, 510	2.05	95	85, 86, 99
$S_2X_2$	510-540	1.98-	104-	86, 462, 463, 477-479
		2.07	105	
$S_2R_2$	495-520	2.04-2.05	102-110	370, 466, 480
$S_2O_n^{2-}$	324-434	1.97-2.39	98-110	400-402, 439, 481, 482
$RS_nX$	450-500 <sup>R</sup>			483
$S_nH_2$	467-509			87, 88
$RS_nH$	450-500 <sup>R</sup>			483
$(RNS)_n$	480-490			144
$RN(S)_nNR$	418-448			467
$ROC(S)SSC(S)OR$	505-510			467
$MS_n$		1.99-2.18	103-110	484-489

R = Raman

<sup>a</sup> Raman shifts for  $S_8$  are 152, 185, 216, 243, 434, 470 and  $520 \text{ cm}^{-1}$

several investigators are in good agreement. There are, however, many discrepancies between the assignments made for these compounds<sup>86,462,463</sup>, particularly in the cases of  $Me_2S_2$  and  $S_2Cl_2$ .

The variation of the vibrational frequencies in the compounds  $H_2S_2$ ,  $Me_2S_2$ ,  $S_2F_2$ ,  $S_2Cl_2$ , and  $S_2Br_2$ , with the mass of the atoms attached to sulphur lends support to the assignments due to Hooze and Ketelaar<sup>86</sup>. In these  $XS_2X$  molecules the highest frequency remains fairly constant at  $510-540 \text{ cm}^{-1}$ . Since the vibration is not greatly influenced by substituents on the sulphur atoms, it was assigned to the S-S stretching vibration. For  $S_2Cl_2$ , Gerding and Westrik<sup>462</sup>, and Vogel-Högler<sup>464</sup> disagree with the assignments made by Hooze and Ketelaar<sup>86</sup>. Assignment of the Raman frequencies of  $S_2Br_2$  by Stammreich and Forneris<sup>465</sup> has been made by analogy with

the assignment for  $S_2Cl_2$  by Gerding and Westrik<sup>462</sup> The infrared spectra of  $Et_2S_2$  and  $(C_3H_7)_2S_2$  show S-S stretching frequencies at 507 and 502  $cm^{-1}$  respectively<sup>86</sup> Cyclic molecules containing sulphur-sulphur linkages have been investigated by several workers<sup>144,147,466-470</sup>, the S-S stretching frequency falling within the range 400-500  $cm^{-1}$ . Many organic sulphur compounds also absorb within this range

There is little spectral information on compounds containing S=S double bonds. Disulphur monoxide<sup>471</sup> is a bent triatomic molecule with two stretching modes ( $\nu_{SO}$  at 1165  $cm^{-1}$ ,  $\nu_{SS}$  at 679  $cm^{-1}$ ) and one bending mode (388  $cm^{-1}$ ) The S=S stretching frequency in  $S=SF_2$  has been reported<sup>472</sup> at 715  $cm^{-1}$

Abrahams<sup>363</sup> has reviewed the observed variations in S-S bond lengths and S-S-S bond angles The data in Table 5.17 show that for many classes of compound the S-S bond lengths fall within the range 1.97-2.18 Å Lindquist and Mörtzell<sup>377</sup> have suggested that the variations of S-S distance in the ions  $S_2O_4^{2-}$  (2.39 Å),  $S_2O_5^{2-}$  (2.21 Å) and  $S_2O_6^{2-}$  (2.15 Å) supports their thionite-thionate structure for the  $S_2O_3^{2-}$  ion For the greater number of compounds the S-S-S angle is 102-108°

#### 14. Selenium and tellurium

No reports of characteristic stretching frequencies for sulphur-selenium or sulphur-tellurium bonds have been found in the literature Structural data<sup>411-414,490-492</sup> are available for a few compounds of the type  $(RSO_2S)_2Se$  and  $(RSO_2S)_2Te$  The S-Se and S-Te bond lengths are reported in the ranges 2.17-2.20 Å and 2.35-2.41 Å respectively The S-Se-S and S-Te-S bond angles fall in the range 96-103°.

#### 15. Halogens

Infrared frequencies, Raman shifts and X-ray data are summarised in Tables 18-21

##### (a) Sulphur (II) halogen compounds

*XS-SX.* The disulphur dihalides have been studied in some detail, especially with regard to the problem of the relative positions of the two halogen atoms Infrared and Raman data for  $S_2Cl_2$  were originally interpreted in terms of a planar *cis*  $C_{2v}$  model<sup>462,494,495</sup> Raman polarisation measurements were later reinterpreted<sup>461</sup> to support a non-planar ( $C_2$ ) structure The calculated frequencies for  $S_2Cl_2$  ( $C_2$  model) agree with the observed values, so that along with results obtained from electron diffraction<sup>496</sup>, the total evidence is in accordance with a non planar molecular arrangement

*SX<sub>2</sub>* Infrared<sup>499</sup> and Raman<sup>500</sup> spectra, electron diffraction data<sup>480,496,501</sup> and force constant calculations<sup>501,502</sup> for  $SX_2$  are all consistent with  $C_{2v}$  symmetry

Nickless Ch 5 13 1st proof

(b) Sulphur (IV) halogen compounds

$SF_4$  (point group,  $C_{2v}$ ). The infrared and Raman spectra<sup>503</sup> are in accordance with a trigonal bi-pyramidal structure with one equatorial position occupied by a sulphur lone pair. Infrared assignments<sup>503</sup> are.  $\nu_1 = 889$ ,  $\nu_6 = 867$ ,  $\nu_8 = 728$ ,  $\nu_7 = 523$ ,  $\nu_9 = 463 \text{ cm}^{-1}$ . Raman frequencies are close to these values. The infrared band at  $889 \text{ cm}^{-1}$  is assigned to the S-F symmetric stretch and those at  $867$  and  $728 \text{ cm}^{-1}$  involve asymmetrical S-F stretching.  $SF_4$  reacts with  $BF_3$ ,  $AsF_5$  or  $SbF_5$  to form trifluorosulphonium ( $SF_3^+$ ) salts. The SF stretching vibrations in solid  $SF_3^+BF_4^-$  absorb<sup>504</sup> at  $940 \text{ cm}^{-1}$  ( $\nu_s$  SF) and  $908 \text{ cm}^{-1}$  ( $\nu_{as}$  SF).

$S=SF_2$ . The infrared spectrum of  $S=SF_2$  has been reported (see section 13), and the bands at  $757 \text{ cm}^{-1}$  and  $684 \text{ cm}^{-1}$  assigned to the symmetric and asymmetric S-F stretching frequencies respectively<sup>472,497,498</sup>.

$SOX_2$ . The thionyl halides show six infrared and Raman active fundamental vibrations. Their Raman spectra have been shown<sup>505,506</sup> to be consistent with a pyramidal molecular structure ( $C_s$  symmetry, leading to 4 polarised and 2 depolarised lines) rather than a planar arrangement ( $C_{2v}$ , 3 polarised and 3 depolarised lines). Depolarisation factors are not available for  $SOF_2$ .

TABLE 518

FREQUENCY ASSIGNMENTS FOR THIONYL HALIDES

SOF <sub>2</sub>			SOCl <sub>2</sub>		SOBr <sub>2</sub>	Approximate description <sup>437</sup>
Infrared <sup>507</sup>	Raman <sup>508</sup>	Raman <sup>509,437</sup>	Infrared <sup>510-512</sup>	Raman <sup>513</sup>	Raman <sup>506</sup>	
1333	1308	1312	1251		1121	SO stretch
808	801	795	492	490	405	SX <sub>2</sub> stretch(s)
630	526	529		194	267	SO wag
410		326		344	120	SX <sub>2</sub> bend
748	721	720	455	443	379	SX <sub>2</sub> stretch(as)
390	393	395		284	223	SX <sub>2</sub> rock

Long and Bailey<sup>437</sup> have investigated a six constant Urey-Bradley-Simanouti force field for the thionyl halides and although for each molecule a set of force constants can be found which exactly reproduce the observed frequencies, these force constants are not satisfactorily consistent with the physical model underlying the UBS field. This failure arises principally from the neglect of interactions involving the lone pair on the sulphur atom. These authors prefer the  $SOF_2$  assignment of O'Loane and Wilson<sup>597</sup> to that of Gillespie and Robinson<sup>505</sup>.

*NS(IV) Compounds* The sulphur-halogen stretching frequency<sup>159,161</sup> has been assigned in the following compounds -NSF ( $640 \text{ cm}^{-1}$ ), RNSF<sub>2</sub> ( $727$  and  $764 \text{ cm}^{-1}$ )

(c) Sulphur (VI) halogen compounds

$S_2F_{10}$  The infrared spectrum of  $S_2F_{10}$  and the Raman spectrum of the liquid can be interpreted<sup>514-516</sup> on the basis of a staggered  $F_5S-SF_5$  model ( $D_{4d}$ ). This structure is confirmed by electron diffraction experiments<sup>517</sup>, Dodd, Woodward and Roberts<sup>514,515</sup> calculated the frequencies of the eight fundamental modes and these are in agreement with the observed Raman shifts. The seven S-F stretching modes appear in the infrared and Raman spectra between 684 and 938  $cm^{-1}$ . The S-F bond force constant was calculated to be  $4.27 \times 10^5$  dyne  $cm^{-1}$ . The solid state infrared spectrum is similar to the vapour spectrum<sup>514</sup> with additional absorptions due to combination bands intensified by Fermi resonance.

$SF_6$  (point group  $O_h$ ) has six normal modes of vibration, three are Raman active and only two are infrared active<sup>6,60,71,503,518-520</sup>. The five fundamental frequencies are observed at 940(IR), 775(R), 644(R), 615(IR) and 524  $cm^{-1}$ (R), the symmetric SF stretching vibration scatters at 775  $cm^{-1}$ . The nature of the vibrational modes of  $XY_6$  molecules has been discussed in some detail by Herzberg<sup>521</sup>

$SF_5X$ . Replacement of one of the fluorine atoms by chlorine in  $SF_6$  lowers the symmetry to  $C_{4v}$ . Cross and coworkers<sup>522</sup> have assigned the Raman shifts at 834 and 404  $cm^{-1}$  to SF and SCl stretching vibrations respectively. A study<sup>613</sup> of compounds containing  $-SF_5$  showed that this group leads to bands of diagnostic value in the regions 580-610  $cm^{-1}$  (strong) and 860-910  $cm^{-1}$  (very strong)

$SOF_4$  The Raman spectrum of the liquid, and the infrared spectrum of the gas indicate<sup>523</sup> that the structure is analogous to  $SF_4$ , i.e. based on a trigonal bipyramid in which the oxygen atom occupies the equatorial position, which in  $SF_4$  is occupied by the lone pair. The point group is hence  $C_{2v}$ , and of the twelve Raman fundamentals, eleven are infrared active. The  $SF_2$  stretching vibrations have been assigned<sup>523</sup> at 741, 797 and 933  $cm^{-1}$  in the Raman spectrum

$SO_2F_2$ . Sulphuryl fluoride has a slightly aspherical top structure, and electron diffraction<sup>524</sup> and microwave spectra<sup>525</sup> indicate  $C_{2v}$  symmetry. Of the nine normal modes of vibration, eight are infrared active and by analogy with thionyl fluoride where the asymmetric  $SF_2$  stretch occurs at a higher frequency than the symmetric stretch, the infrared bands at 885 and 848  $cm^{-1}$  are assigned<sup>526</sup> to  $\nu_{as}(S-F)$  and  $\nu_s(S-F)$  respectively.

$RSO_2X$ . The Raman<sup>447,527,528</sup> and infrared spectra<sup>21,243,254,257,258,261,262,374,529-531</sup> of a large number of sulphonyl halides have been reported.

Sulphonyl fluorides absorb in the region 780-852  $cm^{-1}$  and this is assigned<sup>527</sup> to the SF stretching frequency. King and Smith<sup>21</sup> report that all sulphonyl chlorides gave a band at 370-390  $cm^{-1}$  characteristic of the S-Cl stretching vibration, and that the introduction of electron withdrawing substituents is accompanied by a shift to higher frequencies. Although S-Cl frequencies of aromatic sulphonyl halides show no precise correlation with the ordinary Hammett substituent parameters, they do give a good linear plot with Taft's  $\sigma$ -values, indicating a direct connection between

stretching frequency and inductive effect of the substituents

The Raman spectra of some sulphonyl bromides<sup>528</sup> give an extraordinarily strong band at about 285 cm<sup>-1</sup>. By comparison with the corresponding chlorides and fluorides, this is assigned to an S-Br stretching vibration. Force constant and bond energy calculations indicate that in all cases the C-S bond is stronger than the S-halogen bonds<sup>528</sup>.

SO<sub>2</sub>Cl<sub>2</sub> Raman<sup>505,532,533</sup> and infrared<sup>510,534</sup> data for sulphuryl chloride are consistent with a roughly tetrahedral molecule (C<sub>2v</sub> symmetry). Such symmetry gives rise to nine fundamentals, all are Raman active and eight are infrared active. There has, however, been some disagreement over the assignments<sup>505,510,533</sup>. The SCl vibrations in the Raman spectrum were assigned<sup>505,533</sup>  $\nu_s(\text{SCl}_2)$  405 cm<sup>-1</sup>,  $\nu_{as}(\text{SCl}_2)$  362 cm<sup>-1</sup>, SCl<sub>2</sub> rock 282 cm<sup>-1</sup>, SCl<sub>2</sub> bend 218 cm<sup>-1</sup>.

SO<sub>2</sub>XY The infrared spectrum<sup>248,249</sup> of SO<sub>2</sub>BrF, and the infrared<sup>247</sup> and Raman<sup>533</sup> spectra of SO<sub>2</sub>ClF have been reported. The S-Hal stretching frequencies in SO<sub>2</sub>BrF have been assigned<sup>248,505,533</sup>  $\nu(\text{SBr})$  270 cm<sup>-1</sup>,  $\nu(\text{SF})$  814 cm<sup>-1</sup>. The Raman shifts for SO<sub>2</sub>ClF have been assigned<sup>533</sup>  $\nu(\text{SCl})$  430 cm<sup>-1</sup>,  $\nu(\text{SF})$  823 cm<sup>-1</sup>.

Infrared and Raman data are available for many other sulphur halogen compounds (Table 5.21) but the sulphur-halogen absorption regions remain within the following limits:

$$\nu(\text{SF}) 496-941 \text{ cm}^{-1}; \nu(\text{SCl}) 372-545 \text{ cm}^{-1}, \nu(\text{SBr}) 280-531 \text{ cm}^{-1}$$

## 16. Transition metals

For the purposes of this review "transition metals" will be taken to include the elements zinc, cadmium and mercury.

The fundamental metal-sulphur stretching frequencies of some binary sulphides

TABLE 5.19

STRETCHING FREQUENCIES AND BOND LENGTHS IN S(II)-HALOGEN COMPOUNDS

Compound	$\nu_{\text{SI}} (\text{cm}^{-1})$		$\nu_{\text{SCl}} (\text{cm}^{-1})$		$\nu_{\text{SBr}} (\text{cm}^{-1})$		$r_{\text{SCl}} (\text{\AA})$	$r_{\text{SBr}} (\text{\AA})$	References
	s	as	s	as	s	as			
S <sub>2</sub> X <sub>2</sub>	745	807	443 <sup>R</sup> 438	537 <sup>R</sup> 538	302 <sup>R</sup>	529 <sup>R</sup> 531	1.99	2.24	386, 461, 462, 465, 477-479, 535-538, 540
SX <sub>2</sub>			514 <sup>R</sup>	535 <sup>R</sup>			2.02		386, 480, 500-502, 542
ArSX			495-514						543, 544
NCSX			520		451				545
NCSX <sub>3</sub>			542		450				545, 546
Cl <sub>3</sub> CSX			533 <sup>R</sup> 532						547, 548

Nickless Ch 5-4/ 1st proof



TABLE 5 20

## STRETCHING FREQUENCIES AND BOND LENGTHS IN S(VI)-HALOGEN COMPOUNDS

Compound	$\nu_{\text{SF}}(\text{cm}^{-1})$		$\nu_{\text{SCl}}(\text{cm}^{-1})$		$\nu_{\text{SB}}(\text{cm}^{-1})$		$r_{\text{SF}}(\text{\AA})$	$r_{\text{SCl}}(\text{\AA})$	$r_{\text{SB}}(\text{\AA})$	References
	s	as	s	as	s	as				
SX <sub>4</sub>	889	867					1 58			50, 503 548-550
SOX <sub>2</sub>	801	721	490	443	405	378	1 60	2 07	2 27	263, 429, 437, 480, * 496, 505-507, 510, 511, 551
NSX (NSX) <sub>4</sub>	640						1 446	2 150		161 187
(NSX) <sub>4</sub> RN=SX <sub>2</sub>	764	727					1 602	2 084		173 159

TABLE 5 21

## STRETCHING FREQUENCIES AND BOND LENGTHS IN S(IV)-HALOGEN COMPOUNDS

Compound	$\nu_{\text{SI}}(\text{cm}^{-1})$		$\nu_{\text{SCl}}(\text{cm}^{-1})$		$\nu_{\text{SB}}(\text{cm}^{-1})$	$r_{\text{SI}}(\text{\AA})$	$r_{\text{SCl}}(\text{\AA})$	References
	s	as	s	as				
SX <sub>6</sub>	775 <sup>R</sup>	615				1 56		71, 72, 552-553
SX <sub>5</sub> Y	624 <sup>R</sup>		404 <sup>R</sup>			1 597		522
	834 <sup>R</sup>							
	703 <sup>R</sup>							
	916 <sup>R</sup>							
S <sub>2</sub> X <sub>10</sub>	913	690				1 56		30, 357, 514-517, 554 523, 550, 555, 556
SOX <sub>4</sub>	933 <sup>R</sup>	797 <sup>R</sup> , 741 <sup>R</sup>						496, 505, 510, 513, 524; 557
SO <sub>2</sub> X <sub>2</sub>	848	885	403	388 <sup>R</sup>		1 53	1 99	247-249, 533
			408					357
SO <sub>2</sub> XY	813					1 56		21, 243, 254, 257, 258, 261, 262, 374, 529-531
SF <sub>5</sub> OF								262
RSO <sub>2</sub> X	780-852		372-390		285			199, 247, 252, 253
ROSO <sub>2</sub> X	832-852							505
R <sub>2</sub> NSO <sub>2</sub> X	794-901							529
S <sub>2</sub> O <sub>5</sub> X <sub>2</sub>	872 <sup>R</sup>		412 <sup>R</sup>	427 <sup>R</sup>				251
S <sub>2</sub> O <sub>6</sub> X <sub>2</sub>	843							318
S <sub>2</sub> O <sub>8</sub> X <sub>2</sub>			412 <sup>R</sup>	434 <sup>R</sup>				261
S <sub>2</sub> O <sub>5</sub> XY			432 <sup>R</sup>					257
XOSO <sub>2</sub> X	852							559
SO <sub>2</sub> X <sup>-</sup>	496							560
R <sub>3</sub> C-SX <sub>5</sub>	850-903							199
(RN=) <sub>2</sub> SX <sub>2</sub>	833-883							161
(NSOX) <sub>n</sub>	833							181
NSX <sub>3</sub>	775					1 416		
(NSOX) <sub>3</sub>							2 003	

are given in Table 5.22. As expected the frequency decreases in passing from zinc to cadmium<sup>575</sup>. The anomalously high frequency for cinnabar<sup>576</sup> results from the tendency of Hg(II) to become linearly two coordinated. The rare zinc blende form of mercuric sulphide would presumably<sup>601</sup> absorb at 200 cm<sup>-1</sup>. Downs, Ebsworth and Emeléus have assigned the strongly polarised Raman line at 243 cm<sup>-1</sup> in (CF<sub>3</sub>S)<sub>2</sub>Hg to  $\nu_{\text{Hg-S}}$  and have reported similar absorptions in related compounds<sup>577</sup>. Goggin and Woodward<sup>578</sup> in a tentative assignment of the Raman spectrum of the (MeHgSMe<sub>2</sub>)<sup>2+</sup> ion in aqueous solution, place  $\nu_{\text{Hg-S}}$  at 302 cm<sup>-1</sup>. There is, however, substantial mixing of this and the -SC<sub>2</sub>-bending mode.

Recent infrared studies<sup>562,574,585</sup> of M<sub>2</sub>(MoS<sub>4</sub>), M<sub>2</sub>(WS<sub>4</sub>), and M<sub>2</sub>(CuS<sub>4</sub>) compounds have shown the asymmetric M-S stretching frequency ( $\nu_3$ ) to lie within the range 440-480 cm<sup>-1</sup>, one of the deformation modes ( $\nu_4$ ) occurs near 150 cm<sup>-1</sup>.

TABLE 5.22\*

METAL-SULPHUR STRETCHING FREQUENCIES CENTRALIZE

Compound	$\nu_{\text{M-S}}$ (cm <sup>-1</sup> )	References
ZnS	310	575
CdS	220	575
HgS(cinnabar)	349	576
Hg(SCF <sub>3</sub> ) <sub>2</sub>	243	577
Hg(SCF <sub>3</sub> )Cl	251	577
Hg(SCF <sub>3</sub> )Br	264	577
NMe <sub>4</sub> [Hg(SCF <sub>3</sub> ) <sub>2</sub> Cl]	223	577
NMe <sub>4</sub> [Hg(SCF <sub>3</sub> ) <sub>2</sub> Br]	222	577
NMe <sub>4</sub> [Hg(SCF <sub>3</sub> ) <sub>2</sub> I]	219	577

\* From Adams (Ref 601)

Adams<sup>561</sup> has presented a preliminary report of infrared and Raman investigations of metal complexes with various sulphur ligands, including thiourea, dithiolates and dialkyl sulphides. Nakamoto *et al.* have made two important studies using normal coordinate analysis, of the in-plane vibrations of dithiocarbamate<sup>579</sup> and dithiooxalate<sup>580</sup> systems. For the latter system the band at 322 cm<sup>-1</sup> and the doublet at 436,422 cm<sup>-1</sup> (split by interaction between the rings) can be described as  $\nu(\text{Pt-S})$ . For the dithiocarbamates a band at 375 cm<sup>-1</sup> is due largely to  $\nu(\text{Pt-S})$ , but two further absorptions at 560 and 288 cm<sup>-1</sup> are complex modes involving both Pt-S bond stretching and ring deformation. Watt and McCormick<sup>582</sup> have investigated the spectra of the related xanthate complexes and assigned bands at 360 and 330 cm<sup>-1</sup> to  $\nu(\text{M-S})$ , and by analogy with this, Schrauzer and Mayweg<sup>581</sup> have assigned bands near 400 and 350 cm<sup>-1</sup> in diethiethene complexes M(S<sub>2</sub>C<sub>2</sub>R<sub>2</sub>)<sub>2</sub> to  $\nu(\text{M-S})$ .

For PdCl<sub>2</sub>(RS·C<sub>2</sub>H<sub>4</sub> SR), R = Me, Coates and Parkin<sup>584</sup> assigned a strong band at 338.5 cm<sup>-1</sup> as  $\nu(\text{Pd-S})$ , but were unable to find a similar band for the corresponding ethyl complex. For R = Ph however, strong bands at 331 and 312 cm<sup>-1</sup> have been

Nickless Ch 5 - 4/81 1st proof

TABLE 5.23

## METAL-SULPHUR STRETCHING FREQUENCIES IN CHELATE SYSTEMS

Compound	M-S( $\text{cm}^{-1}$ )			References
	M= Ni	Pd	Pt	
$\text{M}(\text{S}_2\text{C}_2\text{O}_2)_2$			436	} 580
			422	
			322	
$\text{M}(\text{S}_2\text{CNH}_2)_2$			560	} 579
			288	
			375	
$\text{M}(\text{S}_2\text{COMe})_2$	383	347	362	} 582
	360	335	330	
$\text{M}(\text{S}_2\text{C}_2\text{Ph}_2)_2$	408	401	403	} 581
	352	352	373	

\* From Adams (Ref 601)

TABLE 5.24

Compound	M-S bond length ( $\text{\AA}$ )	References
$\text{MnS}_2$	2.59	488
$\text{FeS}_2$	2.26	488
$\text{CoS}_2$	2.315	488
$\text{Co}_9\text{S}_8$	octahedral 2.39	566
	tetrahedral 2.21	566
$\text{NiS}_2$	2.396	488
$\text{Ni}(\text{CH}_3\text{N}_3\text{S})_2$	2.155	567
$\text{Ni}[\text{P}(\text{CH}_2\text{CH}_2\text{S})_2\text{CH}_2\text{CH}_2\text{SH}]$	2.16 and 2.22	587
$\text{Ni}(\text{CH}_5\text{N}_3\text{S})_2\text{SO}_4 \cdot 3\text{H}_2\text{O}$	2.16	588
$\text{Cu}_{12}\text{Sb}_{14}\text{S}_{18}$	2.234, 2.272 and 2.342	568
$\text{ZrOS}$	2.74	569
$\text{MoS}_2$	2.41	602
$\text{Mo}_2\text{S}_3$	2.36	564
$\text{MoS}_4^{2-}$	2.17	565
$\text{Mo}(\text{C}_2\text{H}_2\text{S}_2)_3$	2.33	570
$\text{Pt}(\text{SN})_4$	2.23 and 2.25	571
$\text{Pd}[\text{S}=\text{C}(\text{NH}_2)_2]_4\text{Cl}_2$	2.33 and 2.35	572
$\text{Pd}_4\text{S}$	2.34 and 2.48	563

assigned to  $\nu(\text{Pd-S})$  by Pluscec and Westland<sup>583</sup>, who have also prepared  $\text{MX}_2(\text{PhS}, \text{C}_3\text{H}_6\text{SPh})$ , ( $\text{M} = \text{Pd}, \text{Pt}; \text{X} = \text{Cl}, \text{Br}$ ). M-S stretching frequencies in chelate systems are summarised in Table 5.23.

Structural data on several first and second row transition metal sulphides and complexes is available and is given in Table 5.24. The M-S bond length varies from 2.15  $\text{\AA}$  in  $\text{Ni}(\text{SN}_3\text{CH}_3)_2$  to 2.74  $\text{\AA}$  in  $\text{ZrOS}$

Nickless Ch 5-49 1st proof

### Acknowledgement

The authors are indebted to the following for helpful advice and discussion. Professor G. E. Coates, Dr A. J. Downs, Mr. J. R. House, Dr J. M. Smith, Dr. B. P. Straughan, and Dr M. Weston. The authors will be grateful to receive notification of any omissions or errors

### REFERENCES

- 1 W GORDY, *J Chem Phys*, 14 (1946) 305
- 2 R M BADGER, *J Chem Phys*, 3 (1935) 710
- 3 D STEBLE, *Quart Rev*, 18 (1964) 21
- 4 G M BARROW, *Introduction to Molecular Spectroscopy*, McGraw-Hill, New York, 1962
- 5 R E DODD, *Chemical Spectroscopy*, Elsevier, Amsterdam, 1962
- 6 G HERZBERG, *Molecular Spectra and Molecular Structure*, Vol II, Van Nostrand, New York, 1945
- 7 W J POTTS, *Chemical Infrared Spectroscopy*, Vol I, Wiley, New York, 1963
- 8 C N R RAO, *Chemical Applications of Infrared Spectroscopy*, Academic Press, New York, 1963
- 9 E B WILSON, J C DECIJS AND P C CROSS, *Molecular Vibrations*, McGraw-Hill, New York, 1955
- 10 J C D BRAND AND J C SPEAKMAN, *Molecular Structure*, Arnold, London, 1960
- 11 K NAKAMOTO, *Infrared Spectra of Inorganic and Coordination Compounds*, Wiley, New York, 1963
- 12 V F KULIK, YU P EGOROV, M S MARENETS AND L M YAGUPOL'SKII, *Zh Strukt Khim*, 4 (1963) 541
- 13 B BONINI, S GHERSETTI AND G MODENA, *Gazz*, 93 (1963) 1222
- 14 A W BAKER AND A T SHULGIN, *J Am Chem Soc*, 81 (1959) 1523
- 15 G L CALDOW AND H W THOMPSON, *Spectrochim Acta*, 13 (1958) 212
- 16 L J BELLAMY, *J Chem Soc*, (1955) 2818
- 17 R D KROSS AND V A FASSEL, *J Am Chem Soc*, 78 (1956) 4225
- 18 H W THOMPSON AND D A JAMESON, *Spectrochim Acta*, 13 (1958) 236
- 19 S GHERSETTI, *Boll Sci Fac Chim Ind Bologna*, 21 (1963) 237
- 20 S GHERSETTI AND C ZAULI, *Ann Chim (Italy)*, 53 (1963) 710
- 21 J F KING AND D J H SMITH, *Canad J Chem*, 43 (1965) 1870
- 22 L J BELLAMY, *J Chem Soc*, (1955) 4221
- 23 W H LUNN, *Spectrochim Acta*, 16 (1960) 1088
- 24 H W THOMPSON, *Spectrochim Acta*, 16 (1960) 238
- 25 D G O'SULLIVAN AND P W SADLER, *J Chem Soc*, (1957) 4144
- 26 D COOK, *J Am Chem Soc*, 80 (1958) 49
- 27 A D WALSH, *Proc Roy Soc*, A207 (1951) 13
- 28 E A ROBINSON, *Canad J Chem*, 39 (1961) 247
- 29 L W DAASCH, *Spectrochim Acta*, 13 (1958) 257
- 30 J K WILMSHURST, *Canad J Chem*, 35 (1957) 937
- 31 R E KAGARISE, *J Am Chem Soc*, 77 (1955) 1377
- 32 R W BROCKMAN AND D E PEARSON, *J Am Chem Soc*, 74 (1952) 4128
- 33 M L JOSIEN, N FUSON AND D C PEARSON, *Compt Rend*, 235 (1952) 1206
- 34 M L JOSIEN AND N FUSON, *Bull Soc Chim France*, (1952) 389
- 35 M L JOSIEN AND N FUSON, *Compt Rend*, 234 (1952) 1680
- 36 M TAMRES AND S SEARLES, *J Am Chem Soc*, 81 (1959) 2100
- 37 N J BRIDGE AND A D BUCKINGHAM, *Trans Faraday Soc*, 59 (1963) 1497.
- 38 L HERMAN, H GRENAT AND J AKRICHE, *Bull Soc Chim Belges*, 71 (1962) 707
- 39 K H ILLINGER AND D E FREEMAN, *J Mol Spectroscopy*, 9 (1962) 191
- 40 E AUGDAHL AND P KLAEBOE, *Acta Chem Scand*, 18 (1964) 18
- 41 R E HESTER AND R A PLANE, *Inorg Chem*, 3 (1964) 769
- 42 R A CUMMINS, *Australian J Chem*, 17 (1964) 838

- 43 R A CUMMINS AND P DUNN, *Australian J Chem*, 17 (1964) 411  
44 G ALLEN AND R O COLCLOUGH, *J Chem Soc*, (1957) 3912  
45 J BRANDMUELLER AND G GLATZER, *Proc Intern Meeting Mol Spec, Ath, Bologna*, 3 (1959) 1100  
46 A R H COLE, L H LITTLE AND A J MICHELL, *Spectrochim Acta*, 21 (1965) 1169  
47 T HATA AND S KINUMAKI, *Nature*, 203 (1964) 1378  
48 T GRAMSTAD, *Spectrochim Acta*, 19 (1963) 829  
49 M L JOSIEN AND P SAUMAGNE, *Bull Soc Chim France*, (1956) 937  
50 R L REDINGTON AND C V BERNY, *J Chem Phys*, 43 (1965) 2020  
51 J A A KETELAAR AND F N HOOGE, *Rec Trav Chim*, 76 (1957) 529  
52 A ANDERSON AND R SAVOIE, *Canad J Chem*, 43 (1965) 2271  
53 A ANDERSON AND R SAVOIE, *U S Unclassified, A D*, (1965) 610365  
54 A W BAKER, *J Phys Chem*, 61 (1957) 450  
55 L J BELLAMY, *Proc Intern Meeting Mol Spec*, 2 (1959) 745  
56 J BICELLI, *Ann Chim (Italy)*, 46 (1956) 661  
57 P BISCARINI AND S GHERSETTI, *Gazz*, 92 (1962) 61  
58 J BRANDMUELLER AND G GLATZER, *Proc Intern Meeting Mol Spec, Ath, Bologna*, 3 (1959) 1100  
59 D A DOWS AND R J GLENNON, *Spectrochim Acta*, 18 (1962) 1117  
60 D A. DOWS AND G M WIEDER, *Spectrochim Acta*, 18 (1962) 1567  
61 J P MATHIEU, L BOUTURE-MATHIEU AND H POULET, *J Phys Radium*, 16 (1955) 781  
62 V W MELOCHE AND G E KALBUS, *J Inorg Nuclear Chem*, 6 (1958) 104  
63 B MOSZYNSKA, *Bull Acad Polon Sci Sei Sci Math, Astron, Phys*, 9 (1961) 323  
64 C ROCCHICCIOLI, *Compt Rend*, 257 (1963) 3851  
65 H SEIDEL, *Naturwiss*, 52 (1965) 257  
66 A I STEKHANOV AND Z A GABRICHIDZE, *Fiz Tverd Tela*, 5 (1963) 3109  
67 Reference 7, p 137  
68 P TARTE AND G NIZET, *Spectrochim Acta*, 20 (1964) 503  
69 S D ROSS, *Spectrochim Acta*, 18 (1962) 1575  
70 K BUIJS, *J Chem Phys*, 36 (1962) 861  
71 A DE LATTRE, *J Chem Phys*, 20 (1952) 520  
72 C W GULLIKSON, J R NIELSEN AND A T STAIR, *J Mol Spectroscopy*, 1 (1957) 151  
73 C R BAILEY, J W THOMPSON AND J B HALE, *J Chem Phys*, 4 (1936) 625  
74 H STAMMREICH, R FORNERIS AND Y TAVARES, *J Chem Phys*, 25 (1956) 1277  
75 P C CROSS, *Phys Rev*, 47 (1935) 7  
76 A H NIELSEN AND H H NIELSEN, *J Chem Phys*, 5 (1937) 277  
77 W G PENNEY AND G B B M SUTHERLAND, *Proc Roy Soc*, 156 (1936) 654  
78 B L CRAWFORD AND P C CROSS, *J Chem Phys*, 5 (1937) 371  
79 Reference 6, p 336  
80 R T BIRGE, *Rev Mod Phys*, 13 (1940) 233  
81 C A BURRUS AND W CORDY, *Phys Rev*, 92 (1953) 274  
82 G M MURPHY AND J E VANCE, *J Chem Phys*, 6 (1938) 426  
83 W BUCHHEIM, *Physik Z*, 36 (1935) 694  
84 F P REDING AND D F HORNIG, *J Chem Phys*, 27 (1957) 1024  
85 N ZENGIN AND P A GIGUÈRE, *Canad J Chem*, 37 (1959) 632  
86 F N HOOGE AND J A A KETELAAR, *Rec Trav chim*, 77 (1958) 911  
87 F FEHÉR AND M BAUDLER, *Z Anorg Chem*, 254 (1947) 251, 289  
88 F FEHÉR AND M BAUDLER, *Z Anorg Chem*, 258 (1949) 132  
89 H W THOMPSON AND N P SKERRETT, *Trans Faraday Soc*, 36 (1940) 812  
90 W E HAINES, R V HELM, C W BAILEY AND J S BALL, *J Phys Chem*, 58 (1954) 270  
91 E L ELSON AND J T EDSALL, *Biochemistry*, 1 (1962) 1  
92 I F TROTTER AND H W THOMPSON, *J Chem Soc*, (1946) 481  
93 R A SPURR AND H F BYERS, *J Phys Chem*, 62 (1958) 425  
94 M L JOSIEN, P DIZABO AND P SAUMAGNE, *Bull Soc Chim France*, (1957) 423  
95 M O BULANIN, G S DENISOV AND R A PUSHKINA, *Opt i Spektroskopiya*, 6 (1959) 754  
96 J B LOHMAN, F P REDING AND D F HORNIG, *J Chem Phys*, 19 (1951) 252  
97 C A BURRUS AND W GORDY, *Phys Rev*, 92 (1953) 274  
98 H C ALLEN AND E K PLYLER, *J Chem Phys*, 25 (1957) 2872

- 99 D P STEVENSON AND J Y BEACH, *J Am Chem Soc*, 60 (1938) 1272  
 100 R W KILB, *J Chem Phys*, 23 (1955) 1736  
 101 T KOJIMA AND T NISHIKAWA, *J Phys Soc Japan*, 12 (1957) 680  
 102 D A RAMSAY, *J Chem Phys*, 20 (1952) 1920  
 103 F J GREENE AND J L MARGRAVE, *J Am Chem Soc*, 81 (1959) 5555  
 104 E WIBERG AND W STURM, *Z Naturforsch*, 10B (1955) 108  
 105 J A FORSTNER AND E L MUETTERTIES, *Inorg Chem*, 5 (1966) 164  
 106 J M LALANCETTE, F BESSETTE AND J BRAULT, *Tetrahedron Letters*, (1965) 2547  
 107 P C H MITCHELL AND R J P WILLIAMS, *J Chem Soc*, (1960) 1912  
 108 J LEWIS, R S NYHOLM AND P W SMITH, *J Chem Soc*, 1961, 4590  
 109 A TRAMER, *J Chim Phys*, 59 (1962) 232  
 110 A TURCO AND C PRECILE, *Nature*, 191 (1961) 66  
 111 R H CRAGG AND M F LAPPERT, *Organometallic Chem Rev*, 1 (1966) 43  
 112 A CABANA, J BRAULT AND J M LALANCETTE, *Spectrochim Acta*, 22 (1966) 377  
 113 M F HAWTHORNE, *J Am Chem Soc*, 83 (1961) 1345  
 114 D M YOUNG AND C D ANDERSON, *J Org Chem*, 26 (1961) 5235  
 115 A WOJCIKI AND M F FARONA, *Inorg Chem*, 3 (1964) 151  
 116 F BASOLO, J L BURMEISTER AND A J POE, *J Am Chem Soc*, 85 (1963) 1700  
 117 O W HAWORTH, R E RICHARDS AND L M VLANZI, *J Chem Soc*, (1964) 3335  
 118 C B BADDILL AND G J JANZ, *Trans Faraday Soc*, 60 (1964) 2009  
 119 L H JONLS, *J Chem Phys*, 25 (1956) 1069  
 120 C E SCHAFFER, *Chem Soc Special Publ* 1959, No 13, p 153  
 121 S E LIVINGSTONE, *Quart Rev*, 19 (1965) 386  
 122 Z V ZVONKOVA AND G S ZHDANOV, *Zh Fiz Khim*, 13 (1949) 1495  
 123 H SCOULOUDI, *Acta Cryst*, 6 (1953) 651  
 124 D FORSTER AND D M L GOODGAME, *J Chem Soc*, (1965) 268  
 125 R BRINGELAND AND O FOSS, *Acta Chem Scand*, 12 (1958) 79  
 126 Z V ZVONKOVA, L I ASTAKHOVA AND V P GLUSHKOVA, *Kristallografiya*, 5 (1960) 547  
 127 H R LINTON AND E R NIXON, *J Chem Phys*, 29 (1958) 921  
 128 E A V EBSWORTH, R TAYLOR AND L A WOODWARD, *Trans Faraday Soc*, 55 (1959) 211  
 129 K A HOOTON AND A L ALLRED, *Inorg Chem*, 4 (1965) 671  
 130 H SCHUMANN AND M SCHMIDT, *J Organomet Chem*, 3 (1965) 485, *Angew Chem (Intern Ed)*, 4 (1965) 1007  
 131 M SCHMIDT AND H SCHUMANN, *Z Anorg Allgem Chem*, 325 (1963) 130  
 132 H KRIEGSMANN AND H CLAUSS, *Z Anorg Allgem Chem*, 300 (1959) 210  
 133 N P EVTUSHENKO, *Ukrain Khim Zh*, 31 (1965) 618  
 134 A FINCH AND J PEARN, *Tetrahedron*, 20 (1964) 173  
 135 W E DAVIDSON, K HILLS AND M C HENRY, *J Organomet Chem*, 3 (1965) 285  
 136 H KRIEGSMANN, *Z Elektrochem*, 61 (1957) 1088  
 137 J D GOLDFARB AND S SUJISHI, *J Am Chem Soc*, 86 (1964) 1679  
 138 A M VUAGNAT AND E L WAGNER, *J Chem Phys*, 26 (1957) 77  
 139 I NAKAGAWA, S MIZUSHIMA, A J SARACENO, T J LANE AND J V QUAGLIANO, *Spectrochim Acta*, 12 (1958) 239  
 140 L P BICELLI, *Ann Chim (Italy)*, 47 (1957) 1380  
 141 L P BICELLI, *Rend Ist Lombardo Sci*, Pt 1, 91 (1957) 76  
 142 E R LIPPINCOTT AND M C TOBIN, *J Chem Phys*, 21 (1953) 1559  
 143 E R LIPPINCOTT AND M C TOBIN, *J Am Chem Soc*, 73 (1951) 4990  
 144 B D STONE AND M L NIELSEN, *J Am Chem Soc*, 81 (1959) 3580  
 145 H GARCIA-FERNANDEZ, *Compt Rend*, 260 (1965) 6107  
 146 H GARCIA-FERNANDEZ, *Compt Rend*, 261 (1965) 745  
 147 H HEAL, *Nature*, 199 (1963) 371  
 148 H HEAL AND J KANE, *Nature*, 203 (1964) 971  
 149 R C BRASTED AND J S POND, *Inorg Chem*, 4 (1965) 1163  
 150 I W HERRICK AND E L WAGNER, *Spectrochim Acta*, 21 (1965) 1569  
 151 P NANNELLI, A FAILLI AND T MOELLER, *Inorg Chem*, 4 (1965) 558  
 152 G TOSOLINI, *Chem Ber*, 94 (1961) 2731

- 153 R C PETERSON, U GREZESKOWIAK AND L H JULES, *J Org Chem*, 25 (1960) 1595  
 154 D HADZI, *J Chem Soc*, (1957) 847  
 155 A MASCHKA AND H AUST, *Monatsh*, 85 (1954) 891  
 156 R J PHILIPPE AND H MOORE, *Spectrochim Acta*, 17 (1961) 1004  
 157 M LUSTIG AND J K RUFF, *Inorg Chem*, 4 (1965) 1444  
 158 W C SMITH, C W TULLOCK, R D SMITH AND V A ENGELHARDT, *J Am Chem Soc*, 82 (1960) 551  
 159 A F CLIFFORD AND C S KOBAYASHI, *Inorg Chem*, 4 (1965) 571  
 160 R D DRESNER, J S JOHAR, J MERRITT AND C S PATTERSON, *Inorg Chem*, 4 (1965) 678  
 161 H RICHERT AND O GLEMSER, *Z Anorg Allgem Chem*, 307 (1961) 328  
 162 O GLEMSER, H MEYER AND A HAAS, *Chem Ber*, 98 (1965) 2049  
 163 D CHAPMAN, R J WARN, A G FITZGERALD AND A D YOFFE, *Trans Faraday Soc*, 60 (1964) 294  
 164 O GLEMSER AND E WYSZOMIRSKI, *Chem Ber*, 94 (1961) 1443  
 165 W L JOLLY, K D MAGUIRE AND D RABINOWICH, *Inorg Chem*, 2 (1963) 1304  
 166 A VANDI, T MOELLER AND T L BROWN, *Inorg Chem*, 2 (1963) 899  
 167 F SEEL AND G SIMON, *Z Naturforsch*, 19B (1964) 354  
 168 L C PAULING, *The Nature of the Chemical Bond*, 3rd ed., Cornell University Press, Ithaca, New York, 1960  
 169 G A JEFFREY AND H P STADLER, *J Chem Soc*, (1951) 1467  
 170 T JORDAN, H WARREN SMITH, L L LOHR AND W N LIPSCOMB, *J Am Chem Soc*, 85 (1963) 846  
 171 K N TRUEBLOOD AND S W MAYER, *Acta Cryst*, 9 (1956) 628  
 172 R L SASS AND J DONOHUE, *Acta Cryst*, 11 (1958) 497  
 173 G A WIEGERS AND A VOS, *Acta Cryst*, 14 (1961) 562, 16 (1963) 152  
 174 R T BAILEY AND E R LIPPINCOTT, *Spectrochim Acta*, 20 (1964) 1327  
 175 D A JOHNSON, G D BLYHOLDER AND A W CORDES, *Inorg Chem*, 4 (1965) 1790  
 176 K DRESSLER, *Helv Phys Acta*, 28 (1955) 563  
 177 P B ZEEMAN, *Canad J Phys*, 29 (1951) 174  
 178 D CLARK, *J Chem Soc*, (1952) 1615  
 179 B D SHARMA AND J DONOHUE, *Acta Cryst*, 16 (1963) 891  
 180 E W LUND AND S R SVENDSEN, *Acta Chem Scand*, 11 (1957) 940  
 181 A C HAZELL, G A WIEGERS AND A VOS, *Acta Cryst*, 20 (1966) 186  
 182 A W CORDES, R F KRUEH AND E K GORDON, *Inorg Chem*, 4 (1965) 681  
 183 J WEISS, *Z Anorg Allgem Chem*, 333 (1964) 314  
 184 J WEISS AND H S NEUBERT, *Acta Cryst*, 18 (1965) 815  
 185 J C VAN DE GRAMPPEL AND A VOS, *Rec Trav Chim*, 84 (1965) 599  
 186 J WEISS, *Z Anorg Allgem Chem*, 305 (1960) 190  
 187 G A WIEGERS AND A VOS, *Proc Chem Soc*, (1962) 387, *Acta Cryst*, 20 (1966) 192  
 188 A J BANISTER AND A C HAZELL, *Proc Chem Soc*, (1962) 282  
 189 J WEISS, *Z Naturforsch*, 16B (1962) 477  
 190 R L SASS, *Acta Cryst*, 13 (1960) 320  
 191 G A JEFFREY AND H P STADLER, *J Chem Soc*, (1951) 1467  
 192 G A JEFFREY AND D W JONES, *Acta Cryst*, 9 (1956) 283  
 193 R F BELT AND N C BAENZIGER, *J Am Chem Soc*, 79 (1957) 316  
 194 W K GLASS AND A D E PULLIN, *Trans Faraday Soc*, 57 (1961) 546  
 195 G KRESZE AND A MASCHKE, *Chem Ber*, 94 (1961) 450  
 196 E S LEVCHENKO, E S KOZLOV, A A KISILENKO AND O V KIRSANOV, *J Gen Chem (U S S R)*, 33 (1963) 2991  
 197 F SEEL AND G SIMON, *Angew Chem*, 72 (1960) 709  
 198 R CRAMER AND D D COFFMAN, *J Org Chem*, 26 (1961) 4010  
 199 G W PARSHALL, R CRAMER AND R E FOSTER, *Inorg Chem*, 1 (1962) 677  
 200 F N HOOGE AND P J CHRISTEN, *Rec Trav Chim*, 77 (1958) 911  
 201 J V BELL, J HEISLTER, H TANNENBAUM AND J GOLDENSON, *J Am Chem Soc*, 76 (1954) 5185  
 202 H SIEBERT, *Z Anorg Allgem Chem*, 275 (1954) 210  
 203 H GERDING AND R WESTRIK, *Rec Trav Chim*, 61 (1942) 842  
 204 H SIEBERT, *Z Anorg Allgem Chem*, 274 (1954) 34  
 205 D E C CORBRIDGE, *J Appl Chem*, 6 (1956) 456  
 206 R A McIVOR, G D MCCARTHY AND G A GRANT, *Canad J Chem*, 34 (1956) 1819

- 207 N I ZEMLYANSKH, V V TURKEVICH, I V MURAVEV AND V V BARYLYUK, *Ukrain Khim Zh*, 30 (1964) 190
- 208 R A MCVOR AND C E HUBLEY, *Canad J Chem*, 37 (1959) 869
- 209 R A CHITTENDEN AND L C THOMAS, *Spectrochim Acta*, 20 (1964) 1679
- 210 G E COATES AND R MUKHFRIE, *J Chem Soc*, (1964) 1295
- 211 H GERDING, J W MAARSEN AND P C NOBEL, *Rec Trav Chim*, 76 (1957) 757
- 212 A B BURG AND K GOSLING, *J Am Chem Soc*, 87 (1965) 2112
- 213 L E TAMMELIN, *Acta Chem Scand*, 11 (1957) 1738
- 214 L ALMASI AND A HANTZ, *Chem Ber*, 97 (1964) 661
- 215 M L DELWAULLE AND F FRANÇOIS, *Compt Rend*, 224 (1947) 1422
- 216 M L DELWAULLE AND F FRANÇOIS, *Compt Rend*, 226 (1948) 894
- 217 M L DELWAULLE AND F FRANÇOIS, *Compt Rend*, 225 (1947) 1308
- 218 R A MCVOR, G A GRANT AND C E HUBLEY, *Canad J Chem*, 34 (1956) 1611
- 219 J R DURIG, F BLOCK AND I W LEVIN, *Spectrochim Acta*, 21 (1965) 1105
- 220 R C GORE, *Discuss Faraday Soc*, 9 (1950) 138
- 221 L W DAASCH AND D C SMITH, *Analyt Chem*, 23 (1951) 853.
- 222 J MICHALSKI, R MIERZECKI AND E RURARZ, *Roczniki Chem*, 30 (1956) 651
- 223 A MENEFFEE, D O ALFORD AND C B SCOTT, *J Org Chem*, 22 (1957) 792
- 224 M VAN MEERSSCHE AND A LÉONARD, *Acta Cryst*, 12 (1959) 1053
- 225 D P STEVENSON AND H RUSSELL, *J Am Chem Soc*, 61 (1939) 3264
- 226 P COPPENS, C H MACGILLARY, S G HOVENKAMP AND H DOUWES, *Acta Cryst*, 15 (1962) 765
- 227 F W B EIPSTEIN, B R PFNFOLD AND Q T TAPSELL, *Inorg Chem*, 4 (1965) 186
- 228 A WFISS AND H SCHATER, *Z Naturforsch*, 18B (1962) 81
- 229 H SCHAFER, G SCHATER AND A WEISS, *Z Naturforsch*, 20B (1965) 811
- 230 P J WHEATLEY, *J Chem Soc*, (1962) 300
- 231 J J DALY, *J Chem Soc*, (1964) 4065
- 232 S VAN HOUTEN, A VOS AND G A WIEGERS, *Rec Trav Chim*, 74 (1955) 1167
- 233 O HASSEL AND A PETTERSEN, *Tidsskr Kjemt Bergvesen Met*, 1 (1941) 57
- 234 S VAN HOUTEN AND E H WIEBENGA, *Acta Cryst*, 10 (1957) 156
- 235 A VOS AND E H WIEBENGA, *Acta Cryst*, 8 (1955) 217
- 236 D T DIXON, F W B EINSTEIN AND B R PENFOLD, *Acta Cryst*, 18 (1965) 221
- 237 H J HOFMANN AND K ANDRESS, *Z Anorg Allgem Chem*, 284 (1956) 234
- 238 O GLEMSER AND H PERL, *Naturwiss*, 48 (1961) 620
- 239 E C STUMP, C D PADGETT AND W S BREY, *Inorg Chem*, 2 (1963) 648
- 240 H THIELEMANN, H A SCHLOTTER AND M BECKE-GOEBRING, *Z Anorg Allgem Chem*, 329 (1964) 235
- 241 J K RUFF, *Inorg Chem*, 4 (1965) 567
- 242 D KLAMANN, U KRAMER AND P WEYERSTAHL, *Chem Ber*, 95 (1962) 2694
- 243 L K HUBER AND H C MANDELL, *Inorg Chem*, 4 (1965) 919
- 244 F FEHÉR AND G MORGENSTERN, *Naturwiss*, 25 (1937) 618
- 245 R A ZINGARO, R E MCGLOTHIN AND R M HFDGES, *Trans Faraday Soc*, 59 (1963) 798
- 246 L J BELLAMY AND R L WILLIAMS, *J Chem Soc*, (1957) 863
- 247 H W ROESKY AND A HOFF, *Chem Ber*, 98 (1965) 2429
- 248 M LUSTIG, *Inorg Chem*, 4 (1965) 104
- 249 T T CROW AND R T LAGEMANN, *Spectrochim Acta*, 12 (1958) 143
- 250 M J FRAZER, W GERRARD AND F W PARRETT, *J Chem Soc*, (1965) 342
- 251 A SIMON AND R LEHMANN, *Z Anorg Allgem Chem*, 311 (1961) 212
- 252 M LUSTIG, C L BUMGARDNER, F A JOHNSON AND J K RUFF, *Inorg Chem*, 3 (1964) 1165
- 253 C L BUMGARDNER AND M LUSTIG, *Inorg Chem*, 2 (1963) 662
- 254 J K RUFF, *Inorg Chem*, 4 (1965) 1446
- 255 G PASS, *J Chem Soc*, (1963) 6047
- 256 B COHEN AND A G MACDIARMID, *Inorg Chem*, 1 (1962) 754
- 257 J M SHREEVE AND G H CADY, *J Am Chem Soc*, 83 (1961) 4521
- 258 M LUSTIG AND G H CADY, *Inorg Chem*, 2 (1963) 388
- 259 H J EMELÉUS AND K J PACKER, *J Chem Soc*, (1962) 771
- 260 F B DUDLEY AND G H CADY, *J Am Chem Soc*, 79 (1957) 513



- 261 F B DUDLEY, G. H CADY AND D F EGGERS, *J Am Chem Soc* , 78 (1956) 290  
262 W P GILBREATH AND G H CADY, *Inorg Chem* , 2 (1963) 496  
263 A VANDI, T MOELLER AND L F AUDRIETH, *J Org Chem* , 26 (1961) 1136  
264 W E DASENT AND D MORRISON, *J Inorg Nuclear Chem* , 26 (1964) 1122  
265 R PAETZOLD AND K AURICH, *Z Anorg Allgem Chem* , 335 (1965) 281  
266 Reference 6, p 167  
267 U AGARWALA, C E REES AND H G THODE, *Canad J Chem* , 43 (1965) 2802  
268 W G PALMER, *J Chem Soc* , (1961) 1552  
269 A SIMON AND H WAGNER, *Z Anorg Allgem Chem* , 311 (1961) 102  
270 D H ANDERSON AND N B WOODALL, *Anal Chem* , 25 (1953) 1906  
271 F A MILLER AND C H WILKINS, *Anal Chem* , 24 (1952) 1253  
272 YU YA KHARITONOV, *Zh Neorgan, Khim* , 6 (1961) 2601  
273 G NEWMAN AND D B POWELL, *Spectrochim Acta*, 19 (1963) 213  
274 J C EVANS AND H J BERNSTEIN, *Canad J Chem* , 33 (1955) 1270  
275 H SIEBERT, *Z Anorg Allgem Chem* , 275 (1954) 225  
276 C ROCCHICCIOLI, *Compt Rend* , 244 (1957) 2704  
277 H G HOULTON AND H V TARTAR, *J Am Chem Soc* , 60 (1938) 544  
278 F A MILLER, G L CARLSON, F F BENTLEY AND W H JONES, *Spectrochim Acta*, 16 (1960) 135  
279 R S KRISHNAN, *Proc Indian Acad Sci* , 23A (1946) 288  
280 R E HESTER, R A PLANE AND G E WALRAFEN, *J Chem Phys* , 38 (1963) 249  
281 J C DECIUS, *Spectrochim Acta*, 21 (1965) 15  
282 J C DECIUS, E H COKER AND G L BRENNAN, *Spectrochim Acta*, 19 (1963) 1281  
283 M HASS AND G B B M SUTHERLAND, *Proc Roy Soc* , A236 (1956) 427  
284 J E GUERCHAIS, A HAUMESSER AND R ROHMER, *Compt Rend* , 260 (1965) 5571  
285 E STEGER AND W SCHMIDT, *Bei Bunsenges Physik Chem* , 68 (1964) 102  
286 T DUPUIS, *Congr Group Avanc Methodes Anal Spectrog Prod Met* , 10e (1957) 109  
287 V ANANTHANARAYANAN, *Indian J Pure Appl Phys* , 1 (1963) 58  
288 G E WOLRAFEN, *J Chem Phys* , 43 (1965) 479  
289 C ROCCHICCIOLI, *Mikrochim Ichnoanal Acta* , 5 (1964) 764  
290 A V KORSHUNOV, A A KOLOVSKII AND R I PODGAETSKAYA, *Opt i Spektroskopiya* , 2 (1963) 299  
291 K TAKEMOTO AND Y SAIKI, *Sekko To Sekkai*, No 61 (1962) 277  
292 M HARMELIN, *Ann Chim (France)* , 8 (1963) 285  
293 H R OSWALD, *Helv Chim Acta*, 48 (1965) 600  
294 J S CHO, F A OLSON AND M E WADSWORTH, *Trans AIME*, 230 (1964) 1419  
295 H TAI AND A L UNDERWOOD, *Anal Chem* , 29 (1957) 1430  
296 I LEVSTEK, *Proc Intern Meeting Mol Spect* , 4th, Bologna, 3 (1959) 123  
297 E PETREANU, S PINCHAS AND D SAMUEL, *J Chem Soc* , (1963) 2822  
298 R S KRISHNAN AND P NEBLAKANTAN, *Indian J Pure Appl Phys* , 3 (1965) 4  
299 J M HUNT, M P WISHERD AND L C BONHAM, *Anal Chem* , 22 (1950) 1478  
300 R I RAZOUK, A SH SALEM AND R SH MIKHAIL, *J Phys Chem* , 64 (1960) 1350  
301 G A ZAITSEV AND B S NEPORENT, *Zh Eksperim i Teor Fiz* , 29 (1955) 857  
302 H TABE, *J Pharm Soc Japan* , 75 (1955) 1304  
303 S D CHATTLRJEE, N N GOSH AND A M NAHA, *J Chem Phys* , 20 (1952) 344  
304 W L JOLLY, *U S Atomic Energy Comm* , *Nat Sci Foundation, Wash D C* , UCRL-2008, 1952, 3  
305 C DUVAL AND J LECOMTE, *J Chim Phys* , 50 (1953) C64  
306 G V JFRE AND C C PATEL, *Canad J Chem* , 40 (1962) 1576  
307 W R MCWHINNIE, *J Inorg Nuclear Chem* , 26 (1964) 21  
308 G PANNETIER, J M BREGBAULT, C LECOUTURIER AND G DJEGA-MARIADASSOUXES, *Bull Soc Chim France*, (1964) 3141  
309 V V PECHKOVSKII AND M A GAISINOVICH, *Zh Neorg Khim* , 9 (1964) 2299  
310 V ANANTHANARAYANAN, *Z Physik* , 166 (196 ) 318  
311 W E DASENT AND T C WADDINGTON, *J Chem Soc* , (1960) 3350  
312 G E WALRAFEN AND D M DODD, *Trans Faraday Soc* , 57 (1961) 1286  
313 R SAVOIE AND A GIGUÈRE, *J Chem Phys* , 41 (1964) 2698  
314 S K HALL AND E A ROBINSON, *Canad J Chem* , 42 (1964) 1113  
315 J CHÉDIN, *Ann Chim (France)* , 8 (1937) 243

Nickless Ch 5 1st proof

- 316 P A GIGUÈRE AND R SAVOIE, *J Am Chem Soc*, 85 (1963) 287  
317 P A GIGUÈRE AND R SAVOIE, *Canad J Chem*, 38 (1960) 2467  
318 R J GILLESPIE AND E A ROBINSON, *Canad J Chem*, 40 (1962) 658  
319 R J GILLESPIE AND E A ROBINSON, *Canad J Chem*, 40 (1962) 644  
320 P J ANTIKAINEN, *Suomen Kem*, 31B (1958) 223  
321 C DUVAL AND J LÉCOMTE, *Compt Rend*, 239 (1954) 249  
322 K OMORI AND P F KERR, *Sci Rept Tohoku Univ, Thud Sei*, 9 (1964) 1  
323 G PANNETIER AND J M BREGHAULT, *Bull Soc Chim France*, (1965) 609  
324 S JAULMES, *Rev Chim Minerale*, 2 (1965) 147  
325 W D KELLER, J H SPOTTS AND D L BIGGS, *Am J Sci*, 250 (1952) 453  
326 K BUIJS, *J Inorg Nuclear Chem*, 24 (1962) 229  
327 A SIMON AND H KUCHLER, *Z Anorg Allgem Chem*, 260 (1949) 161  
328 A SIMON, K WALDMANN AND E STEGER, *Z Anorg Allgem Chem*, 288 (1956) 131  
329 C DUVAL AND J LÉCOMTE, *Bull Soc Chim France*, 11 (1944) 376  
330 T DUPUIS AND M VILTANGE, *Mikrochim Ichnoanal Acta*, (1963) 753  
331 R J GILLESPIE AND E A ROBINSON, *Spectrochim Acta*, 19 (1963) 741  
332 A SIMON AND H RICHTER, *Z Anorg Allgem Chem*, 315 (1962) 196  
333 M SCHMIDT AND T SAND, *Z Anorg Allgem Chem*, 330 (1964) 179  
334 M SCHMIDT AND T SAND, *J Inorg Nuclear Chem*, 26 (1964) 1179  
335 M. E BALDWIN, *J Chem Soc*, (1961) 3123  
336 A V BABAeva, YU YA KHARITONOV AND Z M NOVOZHENYWK, *Zh Neorgan Khim*, 6 (1961) 2263, 2281, A V BABAeva, YU YA KHARITONOV AND I B BARANOVSKII, *Zh Neorgan Khim*, 7 (1962) 1247, A V BABAeva, YU YA KHARITONOV AND E V SHLNDERETSKAYA, *Zh Neorgan Khim*, 7 (1962) 1530  
337 A V BABAeva AND YU YA KHARITONOV, *Dokl Akad Nauk, SSSR*, 144 (1962) 559  
338 G A EARWICKER, *J Chem Soc*, (1960) 2620  
339 K NAKAMOTO, J FUJITA, S TANAKA AND M KOBAYASHI, *J Am Chem Soc*, 79 (1957) 4904  
340 H SIEBERT, *Z Anorg Allgem Chem*, 298 (1959) 51  
341 C G BARRACLOUGH AND M L TOBE, *J Chem Soc*, (1961) 1993  
342 K W BAGNALL, D BROWN AND P J JONES, *Z Anorg Allgem Chem*, (1965) 176  
343 M E BALDWIN, *Spectrochim Acta*, 19 (1963) 315  
344 D BARNARD, J M FABIAN AND H P KOCH, *J Chem Soc*, (1949) 2442  
345 F A COTTON, R FRANCIS AND W D HORROCKS, *J Phys Chem*, 64 (1960) 1534  
346 T CAIRNS, G EGLINGTON AND D T GIBSON, *Spectrochim Acta*, 20 (1964) 31  
347 C C PRICE AND R G GILLIS, *J Am Chem Soc*, 75 (1953) 4750  
348 W D HORROCKS AND F A COTTON, *Spectrochim Acta*, 17 (1961) 134  
349 R S DRAGO AND D W MEEK, *J Phys Chem*, 65 (1961) 1446  
350 M F LAPPERT AND J K SMITH, *J Chem Soc*, (1961) 3224  
351 D W MEEK, W E HATFIELD, R S DRAGO AND T S PIPER, *Inorg Chem*, 3 (1964) 1637  
352 J SELBIN, W E BULL AND L H HOLMES, *J Inorg Nuclear Chem*, 16 (1961) 219  
353 W STROHMEIER AND J F GUTTENBERGER, *Chem Ber*, 97 (1964) 1871  
354 D W MEEK, D K STRAUB AND R S DRAGO, *J Am Chem Soc*, 82 (1960) 6013  
355 V SCHOMAKER AND D P STEVENSON, *J Am Chem Soc*, 63 (1941) 37  
356 R B HARVEY AND S H BAUER, *J Am Chem Soc*, 76 (1954) 859  
357 R A CRAWFORD, F B DUDLEY AND K HEDBERG, *J Am Chem Soc*, 81 (1959) 5287  
358 J W M STEEMAN AND C H MACGILLAVRY, *Acta Cryst*, 7 (1954) 402  
359 D W J CRUICKSHANK, *Acta Cryst*, 17 (1964) 684  
360 W MOFFITT, *Proc Roy Soc*, 200A (1950) 409  
361 D W J CRUICKSHANK, *J Chem Soc*, (1961) 5486  
362 R J GILLESPIE AND E A ROBINSON, *Canad J Chem*, 41 (1963) 2074  
363 S C ABRAHAMS, *Quart Rev*, 10 (1956) 407  
364 W H BAUER, *Acta Cryst*, 17 (1964) 1167  
365 W H BAUER, *Acta Cryst*, 17 (1964) 863  
366 W H BAUER, *Acta Cryst*, 17 (1964) B61  
367 A C LARSON, *Acta Cryst*, 18 (1965) 717  
368 T N MARGULIS AND D H TEMPLETON, *Z Krist*, 117 (1962) 344

- 369 R B RAO, *Acta Cryst*, 14 (1961) 321  
370 H J M BOWEN, *Trans Faraday Soc*, 50 (1954) 452  
371 P A KOKKOROS AND P J RENTZEPERIS, *Z Krist*, 119 (1963) 234  
372 J COING-BOYAT, *Acta Cryst*, 13 (1960) 1018, *Compt Rend*, 253 (1961) 997  
373 M ATOJI AND R E RUNDLE, *J Chem Phys.*, 29 (1958) 1306  
374 A ROUSSET AND R LOCHET, *J Phys Radium*, 6 (1945) 57  
375 M HASS AND G B B M SUTHERLAND, *Proc Roy Soc*, A236 (1956) 427  
376 M R TRUTER, *J Chem Soc*, (1962) 3393  
377 I LINDQVIST AND M MORTSELL, *Acta Cryst*, 10 (1957) 46  
378 M R TRUTER, *J Chem Soc*, (1962) 3400  
379 G HERZBERG, *Molecular spectra and molecular structure*, Vol I, Van Nostrand, New York, 1950  
380 D J MESCHI AND R J MYERS, *J Mol Spectroscopy*, 3 (1959) 405  
381 C C PRICE AND S OAE, *Sulphur Bonding*, Ronald Press, New York, 1962  
382 B POST, R S SCHWARTZ AND I FANKUCHEN, *Acta Cryst*, 5 (1952) 372  
383 D KIVELSON, *J Chem Phys*, 22 (1954) 904  
384 G CRABLE AND W V SMITH, *J Chem Phys*, 19 (1951) 502  
385 R E DININNY AND E L PACE, *J Chem Phys*, 31 (1959) 1630  
386 K J PALMER, *J Am Chem Soc*, 60 (1938) 2360  
387 R WESTRIK AND C H MACGILLAVRY, *Rec Trav Chim*, 60 (1941) 794  
388 R WESTRIK AND C H MACGILLAVRY, *Acta Cryst*, 7 (1954) 764  
389 P A KOKKOROS AND P J RENTZEPERIS, *Acta Cryst*, 11 (1958) 361  
390 P KIERKEGAARD, J M LONGO AND B O MARINDER, *Acta Chem Scand*, 19 (1965) 763, P KIERK-  
GAARD AND J M LONGO, *Acta Chem Scand*, 19 (1965) 1906  
391 J H VAN DEN HENDE AND H BOUTIN, *Acta Cryst*, 17 (1964) 660  
392 R PASCARD, *Compt Rend*, 240 (1955) 2162  
393 P BOURRE-MALADIERRE, *Compt Rend*, 246 (1958) 1063  
394 G E PRINGLE AND T A BROADBENT, *Acta Cryst*, 19 (1965) 426  
395 D W J CRUICKSHANK, *Acta Cryst*, *Acta Cryst*, 17 (1964) 682  
396 K OSAKI, H TADOKORO AND I NITTA, *Bull Chem Soc Japan*, 28 (1955) 524  
397 C J BROWN AND E G COX, *J Chem Soc*, (1940) 1  
398 M NARDELLI AND G FAVA, *Acta Cryst*, 15 (1962) 447  
399 M NARDELLI, G FAVA AND G GIRALDI, *Acta Cryst*, 15 (1962) 227  
400 J D DUNITZ, *Acta Cryst*, 9 (1956) 579  
401 E STANLEY, *Acta Cryst*, 9 (1956) 897  
402 S MARTINEZ, S GARCIA-BLANCO AND L RIVOIR, *Acta Cryst*, 9 (1956) 145  
403 W H BARNES AND A V WENDLING, *Z Krist*, 99 (1938) 153  
404 E STANLEY, *Acta Cryst*, 6 (1953) 187  
405 O FOSS AND A HORDVIK, *Acta Chem Scand*, 18 (1964) 662  
406 O FOSS AND H ZACHARIASEN, *Acta Chem Scand*, 8 (1954) 473  
407 O FOSS AND O TJOMSLAND, *Acta Chem Scand*, 10 (1956) 288  
408 E G COX, G A JEFFREY AND H P STADLER, *J Chem Soc*, (1949) 1783  
409 R WEISS, D GRANDJEAN AND J P WENDLING, *Bull Soc Chim France*, (1964) 3152  
410 D GRANDJEAN, R WEISS AND R KERN, *Compt Rend*, 255 (1962) 964  
411 O FOSS AND O TJOMSLAND, *Acta Chem Scand*, 8 (1954) 1701  
412 O FOSS AND P LARSEN, *Acta Chem Scand*, 1954(8) 1042  
413 S FURBERG AND E H ÖYUM, *Acta Chem Scand*, 42  
414 O FOSS AND E H VIHOVDE, *Acta Chem Scand*, 1032  
415 L H VOGT, J L KATZ AND S E WIBERLEY, *Inorg Chem*, 4 (1965) 1157  
416 I LINDQVIST, *Inorganic Adduct Molecules of Oxo-Compounds*, Academic Press, New York, 1963  
417 R J GILLESPIE, *J Chem Educ*, 40 (1963) 295  
418 H P KOCH AND W E MOFFIT, *Trans Faraday Soc*, 47 (1951) 7  
419 S C ABRAHAMS AND J V SILVERTON, *Acta Cryst*, 9 (1956) 281  
420 C KEIL AND K PLIETH, *Z Krist*, 106 (1955) 388  
421 J TOUSSAINT, *Bull Soc Chim Belges*, 54 (1945) 319  
422 P J WHEATLEY, *Acta Cryst*, 7 (1954) 68  
423 G A JEFFREY, *Acta Cryst*, (1951) 68

- 424 D R LIDE, D E MANN AND R M FRISTROM, *J Chem Phys*, 26 (1957) 734  
425 K J PALMER, *J Am Chem Soc*, 60 (1938) 2360  
426 P W ALLEN AND L E SUTTON, *Acta Cryst*, 3 (1950) 46  
427 L G VORONTSOVA, *Kristallografiya*, 10 (1965) 187  
428 T JORDAN, W SMITH AND W N LIPSCOMB, *Tetrahedron Letters*, (1962) 37  
429 D P STEVENSON AND R A COOLEY, *J Am Chem Soc*, 62 (1940) 2477  
430 R C FERGUSON, *J Am Chem Soc*, 76 (1954) 850  
431 O BASTIANSEN AND H VIERVOLL, *Acta Chem Scand*, 2 (1948) 702  
432 S C ABRAHAMS, *Acta Cryst*, 10 (1957) 417  
433 R HINE, *Acta Cryst*, 15 (1962) 635  
434 W J LEHMANN, *J Mol Spectroscopy*, 7 (1961) 261  
435 P W SCHENK AND R STEUDEL, *Angew Chem Intern Ed, Engl*, 4 (1965) 402  
436 V WANNAGAT AND R PFIBFENSCHNEIDER, *Z Anorg Allgem Chem*, 297 (1958) 151  
437 D A LONG AND R T BAILEY, *Trans Faraday Soc*, 59 (1963) 792  
438 F A KANDA AND A J KING, *J Am Chem Soc*, 73 (1951) 2315  
439 P G TAYLOR AND C A BEEVERS, *Acta Cryst*, 5 (1952) 341  
440 W H ZACHARIASEN AND H E BUCKLEY, *Phys Rev*, 37 (1931) 1295  
441 P KIERKEGAARD AND B NYBERG, *Acta Chem Scand*, 19 (1965) 2189  
442 K B HARVEY, F R MCCOURT AND H F SHURVELL, *Canad J Chem*, 42 (1964) 960  
443 P A GIGUÈRE AND M FALK, *Canad J Chem*, 34 (1956) 1833  
444 R BENT AND W R LADNER, *Spectrochim Acta*, 19 (1963) 931  
445 R W LOVEJOY, J H COLWELL, D F EGGERS AND G D HALSEY, *J Chem Phys*, 36 (1962) 612  
446 R W LOVEJOY, J H COLWELL, D F EGGERS AND G D HALSEY, U S Dept Comm Office, Tech Serv AD 263, 127, (1961)  
447 N S HAM AND A N HAMBLY, *Australian J Chem*, 6 (1953) 33  
448 G MALEWSKI AND H-J WEIGMANN, *Spectrochim Acta*, 18 (1962) 725  
449 W R FEAIRHELLER AND J E KATON, *Spectrochim Acta*, 20 (1964) 1099  
450 A SIMON AND M KRIEGSMANN, *Chem Ber*, 89 (1956) 1718  
451 A SIMON AND H KRIEGSMANN, *Chem Ber*, 89 (1956) 2384  
452 H GERDING AND N F MOERMAN, *Z Phys Chem*, 35B (1937) 216  
453 B WARREN AND J T BURWELL, *J Chem Phys*, 3 (1935) 6  
454 C S VENKATESWARAN, *Proc Indian Acad Sci*, 4A (1936) 345  
455 H GERDING AND R WESTRIK, *Rec Trav Chim*, 62 (1943) 68  
456 S BHAGAVANTAM AND T VENKATARAYUDU, *Proc Indian Acad Sci*, 8A (1938) 115  
457 Tables of Interatomic Distances and Configuration in Molecules and Ions, Special Publication No 11, The Chemical Society, London, 1958  
458 K IKONONE, *J Phys Soc (Japan)*, 8 (1953) 646  
459 L R MAXWELL, V M MOSLEY AND S B HENDRICKS, *Phys Rev*, 50 (1936) 41  
460 G W CHANTRY, A ANDERSON AND H A GEBBIE, *Spectrochim Acta*, 20 (1964) 1223  
461 H J BERNSTEIN AND J POWLING, *J Chem Phys*, 18 (1950) 1018  
462 H GERDING AND R WESTRIK, *Rec Trav Chim*, 60 (1941) 701  
463 J A A KETELAAR, F N HOOGH AND G BLASSE, *Rec Trav Chim*, 75 (1956) 220  
464 R VOGEL-HOGLER, *Acta Phys Austriaca*, 1 (1948) 311  
465 H STAMMREICH AND R FORNERIS, *Spectrochim Acta*, 8 (1956) 46  
466 N SHEPPARD, *Trans Faraday Soc*, 46 (1950) 429  
467 C N R RAO, R VENKATARAGHAVAN AND T R KASTURI, *Canad J Chem*, 42 (1964) 36  
468 C N R RAO AND R VENKATARAGHAVAN, *Canad J Chem*, 42 (1964) 43  
469 L H LITTLI, G W POLING AND J LEJA, *Canad J Chem*, 39 (1961) 745  
470 R KLEMENT, H D HAHNE, H SCHNEIDER AND A WILD, *Chem Ber*, 97 (1964) 1716  
471 U BLUKIS AND R J MYERS, *J Phys Chem*, 69 (1965) 1154  
472 R D BROWN, G P PEZ AND M F O'DWYER, *Australian J Chem*, 18 (1965) 627  
473 A CARON AND J DONOHUE, *Acta Cryst*, 18 (1965) 562  
474 S C ABRAHAMS, *Acta Cryst*, 8 (1955) 661  
475 C S LU AND J DONOHUE, *J Am Chem Soc*, 66 (1944) 818  
476 B MBYER AND E SCHUMACHER, *Helv Chim Acta*, 43 (1960) 1333  
477 P G ACKERMANN AND J E MAYER, *J Chem Phys*, 4 (1936) 377

- 478 Quoted by P W ALLEN AND L E SUTTON, *Acta Cryst*, 3 (1950) 46  
479 E HIROTA, *Bull Chem Soc Japan*, 31 (1958) 130  
480 D P STEVENSON AND J Y BBACH, *J Am Chem Soc*, 60 (1938) 2872  
481 I LINDQVIST AND M MORTSELL, *Acta Cryst*, 10 (1957) 406  
482 J LECOMTE, C DUVAL AND R FRANCK, *Compt Rend*, 257 (1963) 326  
483 F FEHÉR AND W KRUSE, *Chem Ber*, 91 (1958) 2528  
484 S C ABRAHAMS, *Acta Cryst*, 7 (1954) 423  
485 S C ABRAHAMS AND E GRISON, *Acta Cryst*, 6 (1953) 206  
486 O FOSS, *Advances in Inorganic and Radiochemistry*, Vol II, Academic Press, New York, 1960, p 237  
487 W S MILLER AND A J KING, *Z Krist*, 94 (1936) 439  
488 N ELLIDT, *J Chem Phys*, 33 (1960) 903  
489 H FOPPL, E BUSMANN AND F K FRORATH, *Z Anorg Allgem*, 314 (1962) 12  
490 O FOSS AND P ÖYUM, *Acta Chem Scand*, 9 (1955) 1014  
491 P ÖYUM AND O FOSS, *Acta Chem Scand*, 9 (1955) 1012  
492 O FOSS AND E H VIHOUDE, *Acta Chem Scand*, 8 (1955) 1032  
493 S M OHLBERG AND P A VAUGHAN, *J Am Chem Soc*, 76 (1954) 2649  
494 Reference 11 p 97  
495 S VENKATESWARAN, *Indian J Phys*, 6 (1931) 275  
496 K J PALMER, *J Am Chem Soc*, 60 (1938) 2360  
497 F SEEL AND H D GOLITZ, *Z Anorg Chem*, 327 (1964) 32  
498 F SEEL AND H D GOLITZ, *Chimia*, 17 (1963) 207  
499 C OTERO AND J R BARCELO MATUTANO, *Anales Real Soc Españ Fis Quim*, (Madrid), 52B (1956) 291  
500 H STAMMREICH, R FORNERIS AND K SONE, *J Chem Phys*, 23 (1955) 972  
501 Y MORINO, Y MURATA, T ITO AND J NAKAMURA, *J Phys Soc Japan*, 1962, 17, Suppl B-II 37  
502 G NAGARAJAN, *Bull Soc Chim Belges*, 72 (1963) 16  
503 R E DODD, L A WOODWARD AND H L ROBERTS, *Trans Faraday Soc*, 5a (1956) 1052  
504 F SEEL AND O DETMER, *Z Anorg Allgem*, 301 (1959) 113  
505 R J GILLESPIE AND E A ROBINSON, *Canad J Chem*, 39 (1961) 2171  
506 H STAMMREICH, R FORNERIS AND Y TAVARES, *J Chem Phys*, 25 (1956) 1277  
507 J K O'LOANE AND M K WILSON, *J Chem Phys*, 23 (1955) 1313  
508 P BENDER AND J M WOOD, *J Chem Phys*, 23 (1955) 1316  
509 D M YOST, *Proc Indian Acad Sci*, 8A (1938) 333  
510 D E MARTZ AND R T LAGEMANN, *J Chem Phys*, 22 (1954) 1193  
511 C A MCDOWELL, *Trans Faraday Soc*, 49 (1953) 371  
512 K C SCHREIBER, *Anal Chem*, 21 (1949) 1168  
513 R VOGEL-HOGLER, *Acta Phys Austriaca*, 1 (1948) 311  
514 R E DODD, L A WOODWARD AND H L ROBERTS, *Trans Faraday Soc*, 53 (1957) 1545  
515 L A WOODWARD AND H L ROBERTS, *Trans Faraday Soc*, 53 (1957) 1557  
516 D EDELSON, *J Am Chem Soc*, 74 (1952) 262  
517 R B HARVEY AND S H BAUER, *J Am Chem Soc*, 2840  
518 J GAUNT, *Trans Faraday Soc*, 49 (1953) 1122  
519 Reference 7, p 336  
520 R T LAGEMANN AND E A JONES, *J Chem Phys*, 19 (1951) 534  
521 Reference 7, p 122  
522 L H CROSS, H L ROBERTS, P GOGGIN AND L A WOODWARD, *Trans Faraday Soc*, 56 (1960) 945  
523 P L GOGGIN, H L ROBERTS AND L A WOODWARD, *Trans Faraday Soc*, 57 (1961) 1877  
524 D P STEVENSON AND H RUSSELL, *J Am Chem Soc*, 61 (1939) 3264  
525 R M FRISTROM, *J Chem Phys*, 20 (1952) 1  
526 W D PERKINS AND M K WILSON, *J Chem Phys*, 20 (1952) 1791  
527 A SIMON, H KRIEGSMANN AND H DUTZ, *Chem Ber*, 89 (1956) 1883  
528 G GEISELER AND K O BINDERNAGEL, *Z Elektrochem*, 63 (1959) 1140  
529 F B DUDLEY AND G H CADY, *J Am Chem Soc*, 79 (1957) 513  
530 R CRAMER AND D D COFFMAN, *J Org Chem*, 26 (1961) 4010  
531 G GEISELER AND R KUSCHMIERS, *Chem Ber*, 93 (1960) 2041  
532 J CABANNES AND A ROUSSET, *Ann Physique*, 19 (1933) 229

- 533 R J GILLESPIE AND E A ROBINSON, *Spectrochim Acta*, 18 (1962) 1473  
534 G R HUNT AND M L WILSON, *Spectrochim Acta*, 18 (1962) 959  
535 J R BARCELO MATUTANO AND C OTERO, *Anales Real Soc Españ Fis Quím (Madrid)*, 51B (1955) 223  
536 J A KETELAAR, F N HOOGE AND F BLASSE, *Rec Trav Chim*, 75 (1956) 220  
537 E HIROTA, *Bull Soc Chem Japan*, 31 (1958) 130  
538 P G ACKERMANN AND J E MAYER, *J Chem Phys*, 4 (1936) 377  
539 M L DELWAULLE AND F FRANCOIS, *J Chim Phys*, 46 (1949) 87  
540 E HIROTA, *Bull Soc Chem Japan*, 31 (1958) 130  
541 D E SANDS, *J Am Chem Soc*, 87 (1965) 1395  
542 D P STEVENSON AND J Y BEACH, *J Am Chem Soc*, 60 (1938) 2872  
543 L ALMASI AND A HANTZ, *Chem Ber*, 98 (1965) 617  
544 S N NABI AND N SHEPPARD, *J Chem Soc*, (1959) 3439  
545 M J NELSON AND A D E PULLIN, *J Chem Soc*, (1960) 604  
546 F FEHÉR AND K H LINKE, *Chem Ber*, 97 (1964) 2413  
547 N S HAM, *Spectrochim Acta*, 19 (1963) 385  
548 K VENKATESWARLU AND M G KRISHNA PILLAI, *Opt i Spektroskopiya*, 11 (1961) 46, 51  
549 M G KRISHNA PILLAI, K RAMASWAMY AND R PICHAI, *Canad J Chem*, 43 (1965) 463  
550 M G KRISHNA PILLAI, K RAMASWAMY AND R PICHAI, *Australian J Chem*, 18 (1965) 1575  
551 G ALLEN AND C A McDOWELL, *J Chem Phys*, 23 (1955) 209  
552 H BRAUNE AND S KNOKE, *Z Phys Chem*, 21B (1933) 297  
553 D M YOST, C C STEFFENS AND S T GROSS, *J Chem Phys*, 2 (1934) 311  
554 L A WOODWARD AND H L ROBERTS, *Trans Faraday Soc*, 53 (1957) 1557  
555 F B DUDLEY, G H CADY AND D F EGGERS, *J Am Chem Soc*, 78 (1956) 1553  
556 M RADHAKRISHNAN, *J Mol Spectroscopy*, 10 (1963) 111  
557 D R LIDE, D E MANN AND R M FRISTROM, *J Chem Phys*, 26 (1957) 734  
558 N S HAM, A N HAMBLY AND R H LABY, *Australian J Chem*, 13 (1960) 443  
559 N H RAY, *J Chem Soc*, (1963) 1440  
560 M LUSTIG AND J K RUFF, *Inorg Chem*, 4 (1965) 1441  
561 D M ADAMS, *Chemical Society Anniversary Meeting*, Oxford, 1966  
562 G GATTOW AND O ROSENBERG, *Z Anorg Allgem Chem*, 332 (1964) 269  
563 F GRONVOLD AND E ROST, *Acta Cryst*, 15 (1962) 11  
564 F JELLINEK, *Nature*, 192 (1961) 1065  
565 H SCHAFER, G SCHAFER AND A WEISS, *Z Naturforsch*, 19B (1964) 76  
566 S GELLER, *Acta Cryst*, 15 (1962) 1195  
567 L CAVALCA, M NARDELLI AND G FAVA, *Acta Cryst*, 15 (1962) 1139  
568 B J WUENSCH, *Z Krist*, 119 (1964) 437  
569 F JELLINEK, *Acta Chem Scand*, 16 (1962) 791  
570 A E SMITH, G N SCHRAUZER, V P MAYWEG AND W HEINRICH, *J Am Chem Soc*, 87 (1965) 5798  
571 I LINDQVIST AND J WEISS, *J Inorg Nuclear Chem*, 6 (1958) 184  
572 S OI, T KAWASE, K NAKATSU AND H KUROYA, *Bull Chem Soc Japan*, 33 (1960) 861  
573 K J PALMER, *J Am Chem Soc*, 60 (1938) 2360  
574 G M CLARK AND W P DOYLE, *J Inorg Nuclear Chem*, 28 (1966) 381  
575 A MITSUISHI, H YOSHINAGA AND S FUJITA, *J Phys Soc Japan*, 13 (1958) 1235  
576 F A MILLER, G L CARLSON, F F BENTLEY AND W H JONES, *Spectrochim Acta*, 16 (1960) 135  
577 A J DOWNS, E A V EBSWORTH AND H J EMBLEUS, *J Chem Soc*, (1961) 3187, (1962) 1254  
578 P L GOGGIN AND L A WOODWARD, *Trans Faraday Soc*, 58 (1962) 1495  
579 K NAKAMOTO, J FUJITA, R A CONDRADE AND Y MORIMOTO, *J Chem Phys*, 39 (1963) 423  
580 J FUJITA AND K NAKAMOTO, *Bull Chem Soc Japan*, 37 (1964) 528  
581 G N SCHRAUZER AND V P MAYWEG, *J Am Chem Soc*, 87 (1965) 1483  
582 G W WATT AND B J MCCORMICK, *Spectrochim Acta*, 21 (1965) 753  
583 J PLUSCEC AND A D WESTLAND, *J Chem Soc*, (1965) 5371  
584 G E COATES AND C PARKIN, *J Chem Soc*, (1963) 421  
585 G GATTOW, A FRANKE AND A MULLER, *Naturwiss*, 52 (1965) 428  
586 A C HAZELL, *J Chem Soc*, (1963) 5745  
587 R GRONBAEK, *Helv Chim Acta*, in press

- 588 R GRONBAEK AND S E RASMUSSEN, *Acta Chem Scand*, 16 (1962) 2325  
 589 S S MITRA AND P J GILLISSF, pp 47-126 in *Progress in Infrared Spectroscopy*, Vol II, Editor H A SZYMANSKI, Plenum Press, New York, 1964  
 590 K LONSDALE, *Crystals and X-rays*, D Van Nostrand, London, 1949  
 591 C W BUNN, *Chemical Crystallography*, Second Edition, Oxford Univ Press, London, 1961  
 592 M J BUERGER, *Crystal-structure Analysis*, Wiley, New York, 1960  
 593 H LIPSON AND W COCHRAN, *The Determination of Crystal Structures*, Bell, London, 1957  
 594 S C NYBURG, *X-ray Analysis of Organic Structures*, Academic Press, New York, 1961  
 595 L V AZAROFF AND M J BUERGER, *The Powder Method*, McGraw-Hill, New York, 1958  
 596 H P KLUG AND L E ALEXANDER, *X-ray Diffraction Procedures*, Wiley, New York, 1954  
 597 J V SMITH, Editor, *X-ray Powder Data File*, Sets 1-5 (revised), Am Soc Testing Mater., Spec Tech Publ, No 48-J, 1960  
 598 R A ZINGARO, *Inorg Chem*, 2 (1963) 192  
 599 R A ZINGARO AND R M HEDGES, *J Phys Chem*, 65 (1961) 1132  
 600 E STEGER, *Z Elektrochem*, 61 (1957) 1004  
 601 D M ADAMS, *Quant Rev*, to be published  
 602 R G DICKINSON AND L PAULING, *J Am Chem Soc*, 45 (1923) 1466  
 603 M BAUDLER, G FRICKE AND K FICHTNER, *Z Anorg Allgem Chem*, 327 (1964) 124  
 604 R G CAVELL AND H J EMELÉUS, *J Chem Soc*, (1964) 5896  
 605 P J CHRISTEN, L M VAN DER LINDE AND F N HOOGE, *Rec Trav Chim*, 78 (1959) 161  
 606 G CILENTO, D A RAMSAY AND R N JONES, *J Am Chem Soc*, 71 (1949) 2753  
 607 A H COWLEY AND S T COHEN, *Inorg Chem*, 3 (1964) 780  
 608 A H COWLEY AND H STEINFINK, *Inorg Chem*, 4 (1965) 1827  
 609 H G HORN, A MULLER AND O GLEMSER, *Z Naturforsch*, 20A (1965) 746  
 610 CHEN WEN-JU, *Acta Chim Sinica*, 31 (1965) 28  
 611 N I ZEMLYANSKII, V V TURKEVICH, I V MURAV'EV AND V V BARYLYUK, *Ukrain Khim Zh*, 30 (1964) 190  
 612 L ALMASI AND L PASKUCZ, *Chem Ber*, 97 (1964) 623  
 613 L H CROSS, G CUSHING AND H L ROBERTS, *Spectrochim Acta*, 17 (1961) 344  
 614 T S ZIOMEK AND E A PIOTROWSKI, *J Chem Phys*, 34 (1961) 1087

Nickless      Ch 5-61      1st proof

