

housing physical form built possibilities

by

WILLIAM R. BERTSCHE

B.S.E.E. University of Cincinnati 1966

M.S.E.E. University of Wisconsin 1967

Submitted in partial fulfillment of
the requirements for the degree of

MASTER OF ARCHITECTURE

AT THE

MASSACHUSETTS INSTITUTE OF TECHNOLOGY

January 1974

Author

William R. Bertsche

Certified by

Maurice Smith Thesis Supervisor

Accepted by

Chairman, Departmental Committee on Graduate Studies

Rotch





Room 14-0551
77 Massachusetts Avenue
Cambridge, MA 02139
Ph: 617.253.2800
Email: docs@mit.edu
<http://libraries.mit.edu/docs>

DISCLAIMER OF QUALITY

Due to the condition of the original material, there are unavoidable flaws in this reproduction. We have made every effort possible to provide you with the best copy available. If you are dissatisfied with this product and find it unusable, please contact Document Services as soon as possible.

Thank you.

The images contained in this document are of the best quality available.

abstract

This thesis presents a study of the effect of built form in housing. A wide range of built form is compiled via drawings and is useful projectively as a design source for design of present housing.

table of contents

page number

7	introduction
8	associative form
9	built form drawings & discussions
113	projective design
132	references
133	drawing references
134	index

6.

introduction

The first purpose of this thesis is to provide an understanding of the effect of built form on uses, activities, and associations within housing. A second purpose is to compile a wide range of built forms in housing and demonstrate how the forms utilized successfully in the past can be used projectively to design present housing.

Providing an understanding of the effects of built form is accomplished by compiling drawings of a wide range of physical built form and describing how the particular form/built-definition was used successfully to define existing houses. Criteria for selection of forms to be drawn is that the built form be an associative form. Such a form facilitates/expands/suggests/projects whatever activities/uses/associations are intended for/by/within the built form.

Demonstration of how associative form in existing houses can be utilized projectively to design present housing is accomplished by designing a portion of a house based on the compiled drawings and discussions. To facilitate future use of the compiled drawings, they are indexed by Type of Building System and also by Type of Use/Association. This index is found at the end of this thesis.

Selection of associative forms to be drawn were entirely subjective by the author. However, most drawings represent indigenous architecture, some of which is hundreds of years old. Such architecture has been built and refined by its inhabitants through the generations. It is to be expected that during such refinement non-useful forms were minimized or eliminated and the useful forms were retained and refined. Within this context, details of the drawings must be considered in relation to life styles of the inhabitants and regional weather conditions.

During selection of examples of associative form, two assumptions were made:

1. All people associate similarly but with varying degrees of sensitivity to built form. Therefore, the author's personal interruption of the forms is a valid one.
2. Associative form built in the past is equally valid at present, given allowance for changes in life style.

Following each drawing, a two part description is made. First, the associative form evident within the drawing is discussed as it applies to its own context. Second, comments are made as to the success of the form and its general application to present architecture.

The compiled drawings and discussions follow.

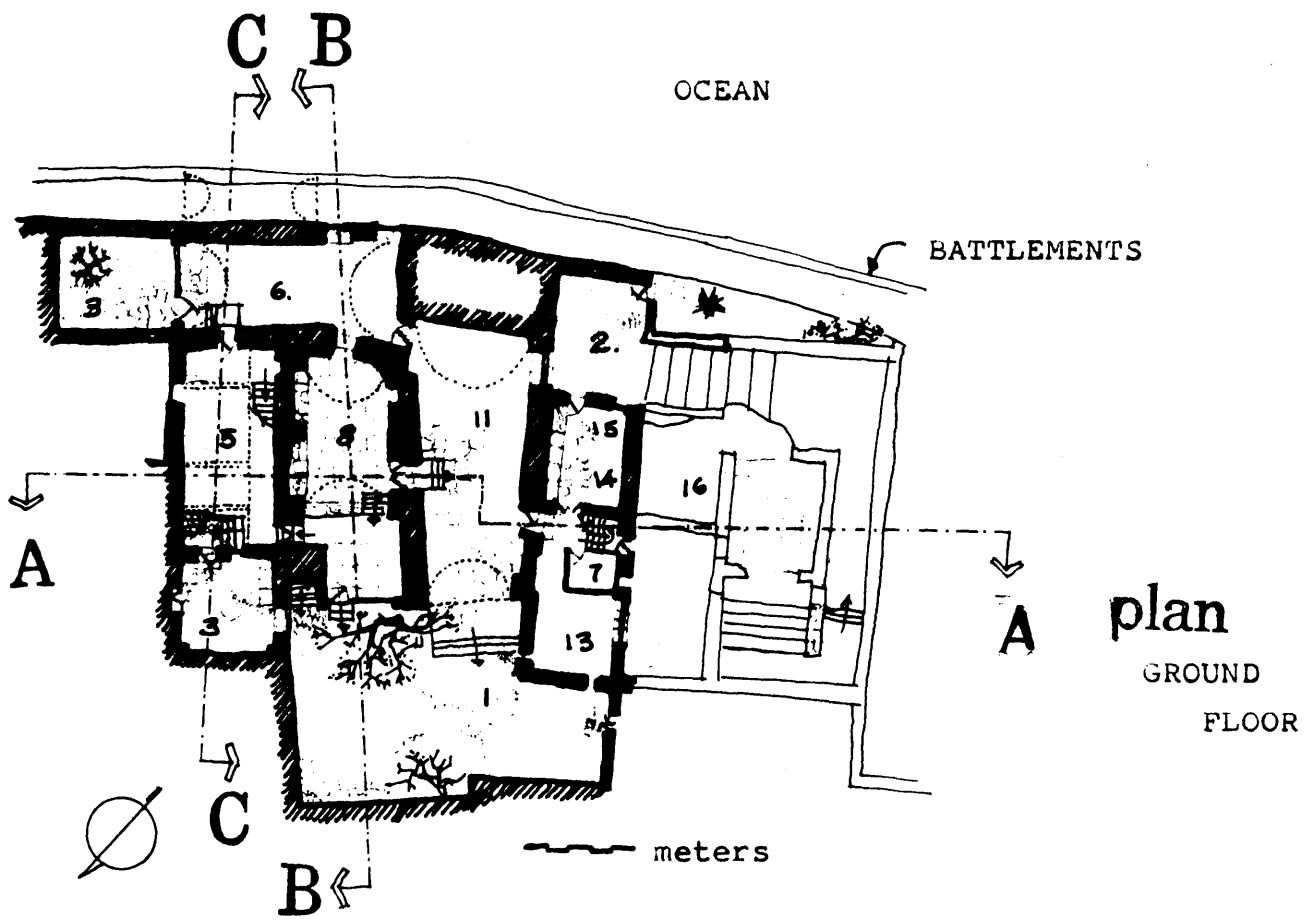

- | | |
|-----------------------|------------------------------|
| 1. ENTRANCE COURT | 9. TERRACE |
| 2. COURT BY THE WALLS | 10. BALCONY OVER BATTLEMENTS |
| 3. SMALL COURT | 11. THE "STREET" |
| 4. SITTING AREA | 12. STUDY |
| 5. DINING AREA | 13. GUEST ROOM |
| 6. BEDROOM | 14. STORAGE |
| 7. BATHROOM | 15. SHOWERS |
| 8. KITCHEN | 16. GARDEN |

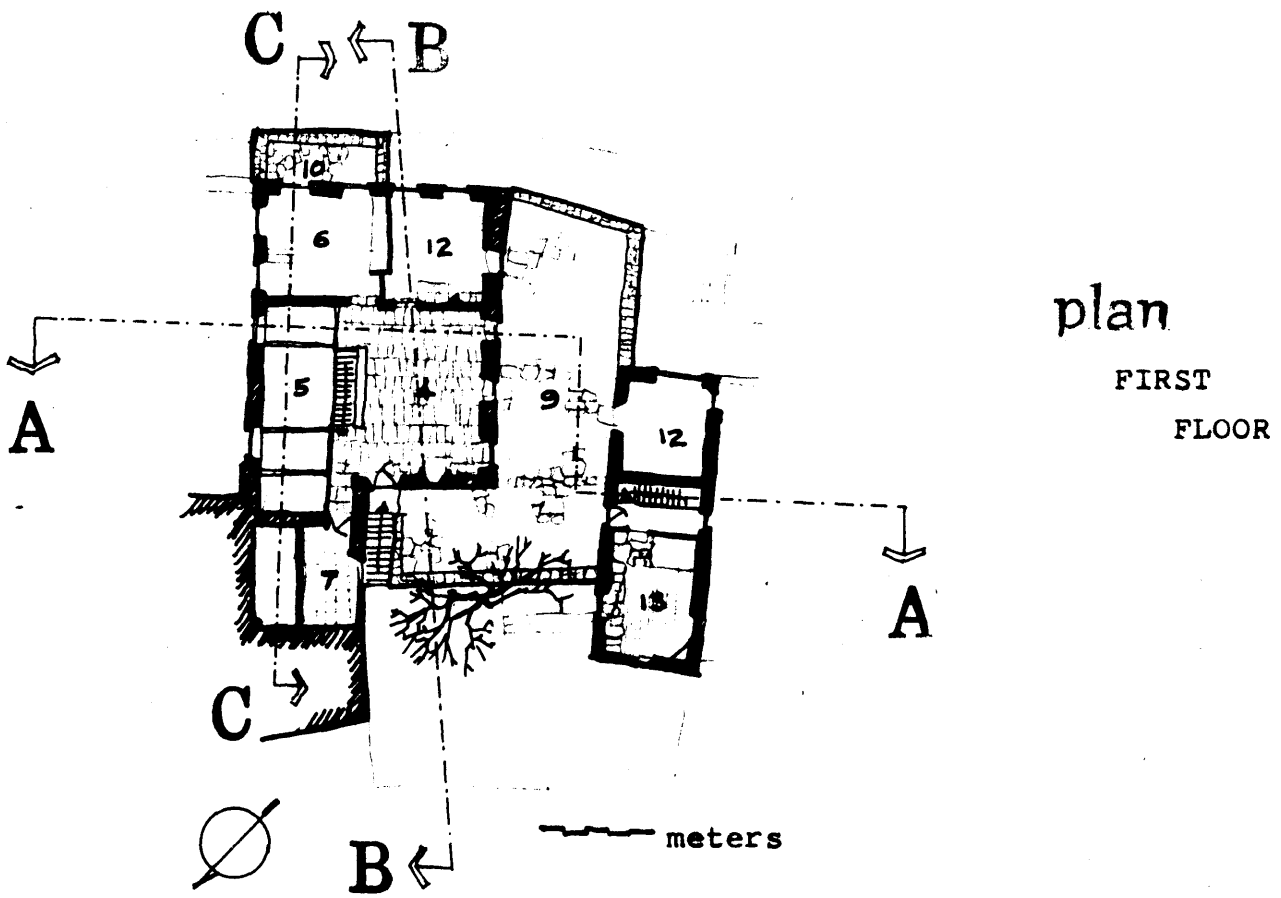

drawing 1

House With A Balcony
Monemvasia on Peloponnesus

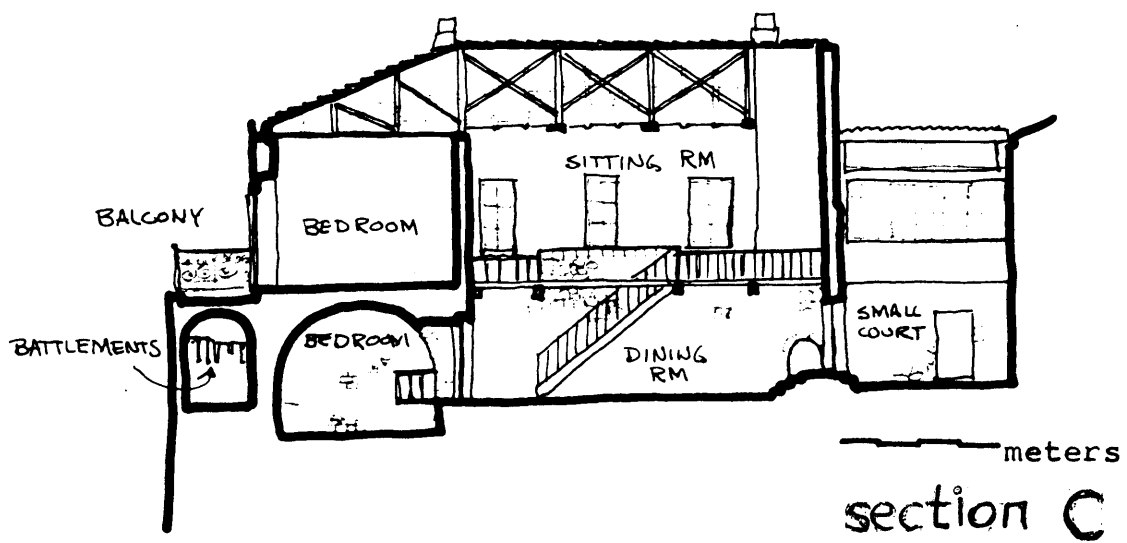
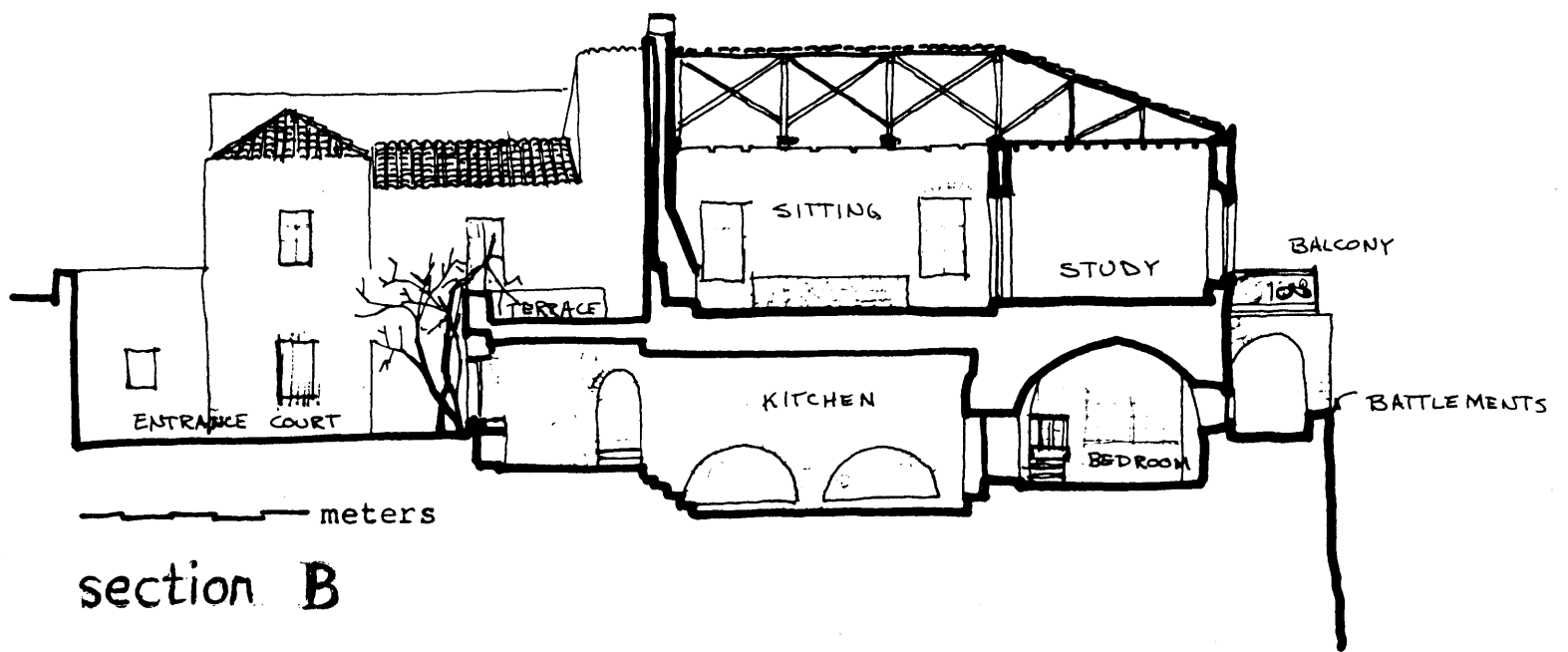
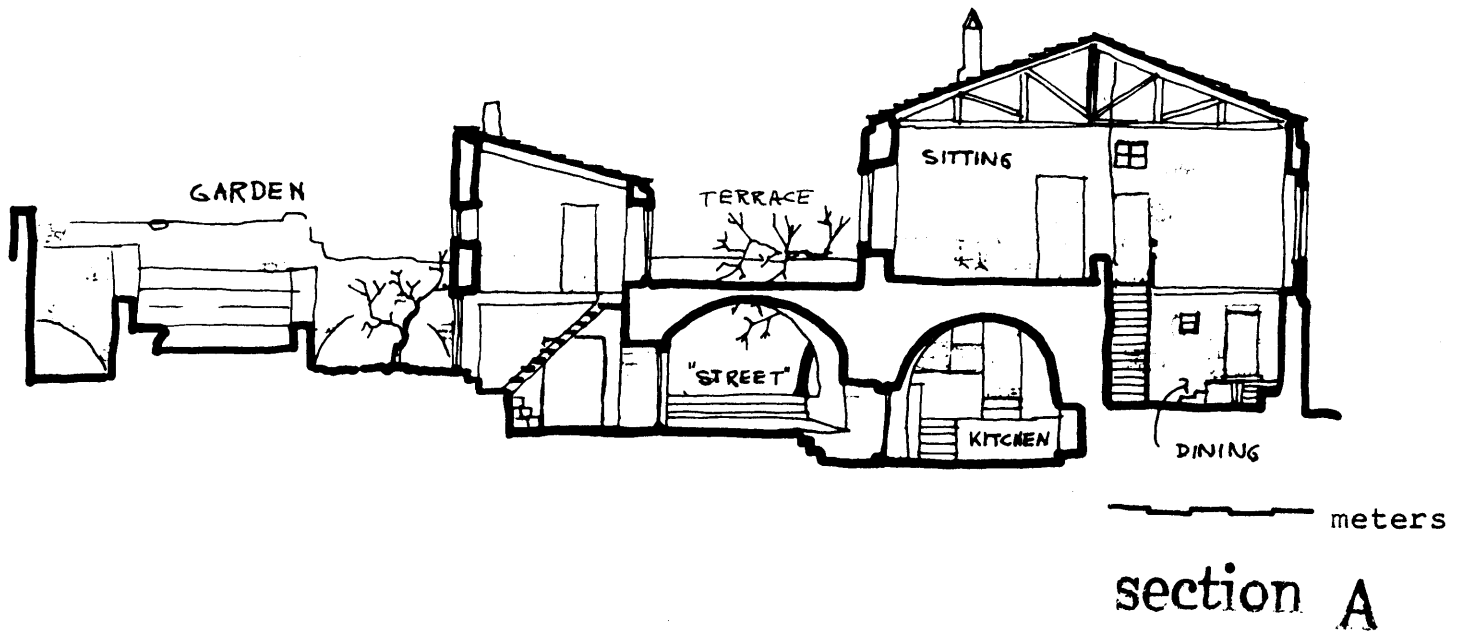

drawing 2

House With a Balcony

drawing 1.2

associative form

1. The multi-level ground floor is closely associated with the original terrain. The stone vaults are built as individual forms related to the ground form, transmitting form and multi-level floors to the rooms above. Within this design, specific use areas/rooms are generally one uniform level with level changes occurring through the door spaces, hallways and stairs.
2. The terrace at the upper level is an elevated ground in form, material and use. In plan, the terrace is above a covered but open "street." Public over public.

Comments

Stone vault construction allows additive building over varied ground form. The ground form creates a rich relationship of inhabitable spaces at all levels at a scale of 15-20 feet. It is interesting that the roof trusses which allow unification of several spaces do little to enhance habitability of the basic spaces.



drawing 3

House With A Balcony
Sitting Room

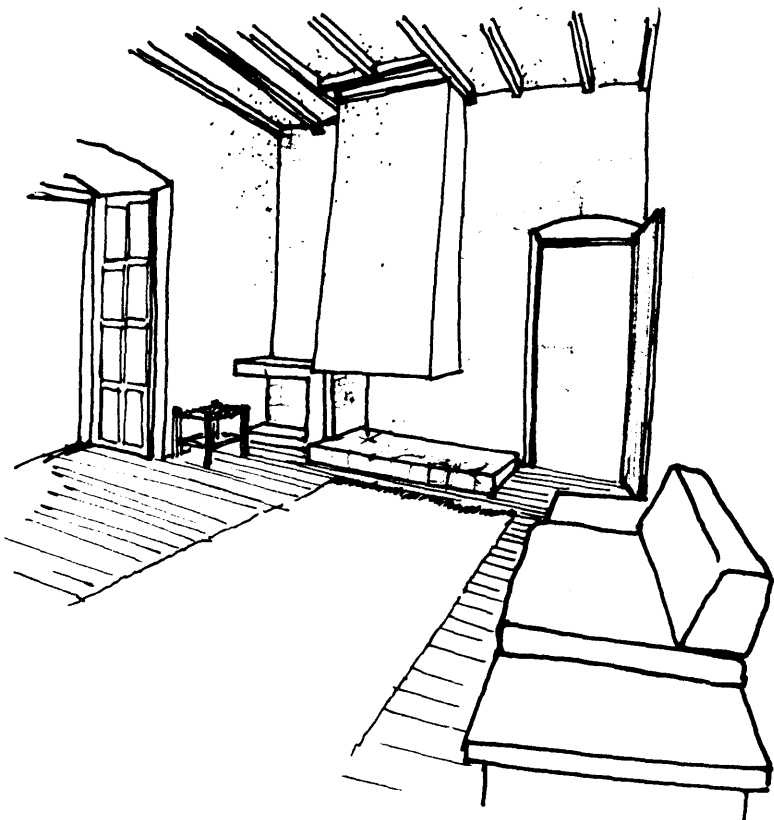

drawing 4

House With A Balcony
Study

drawing 5

House With A Balcony

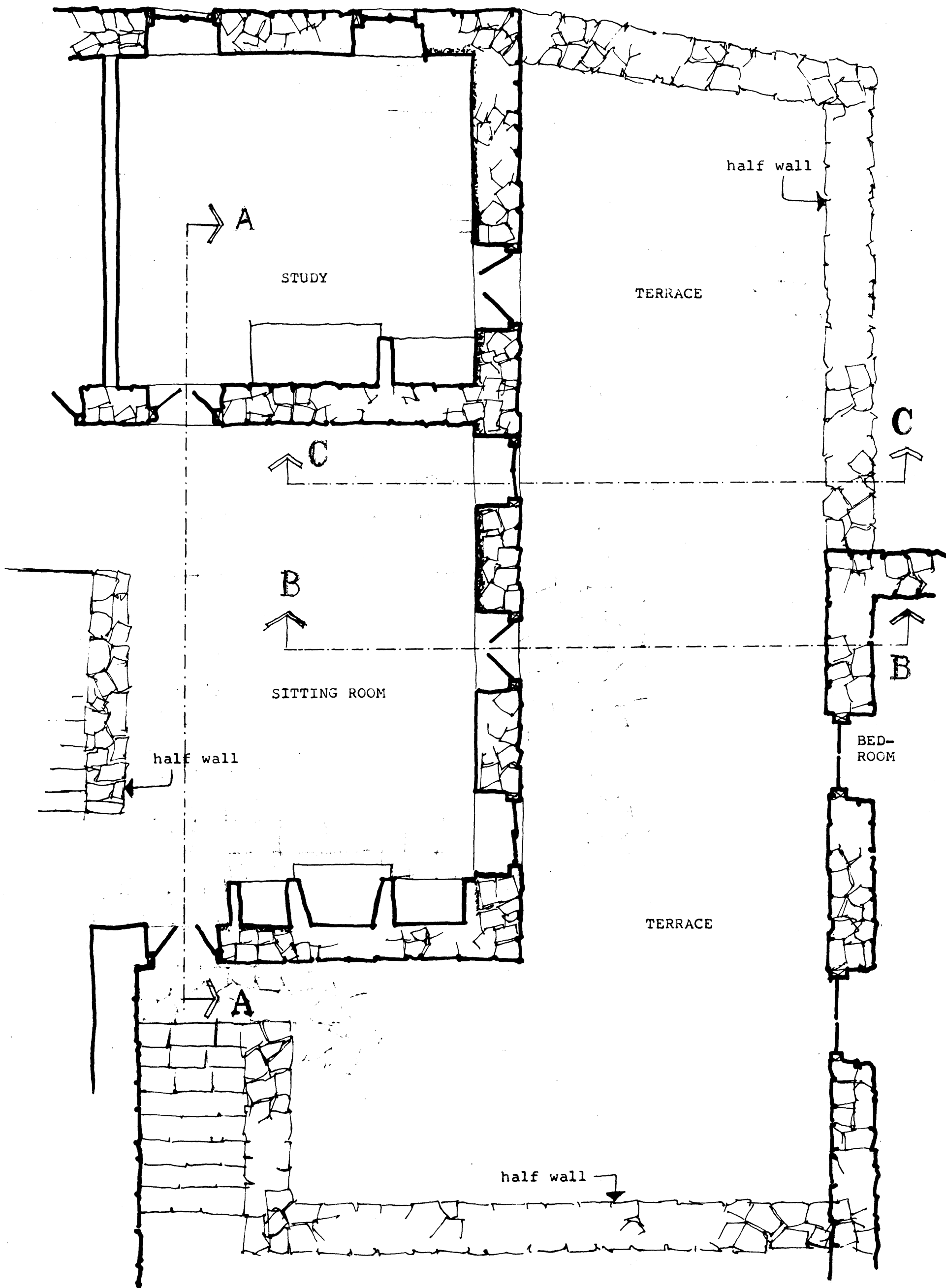

14.

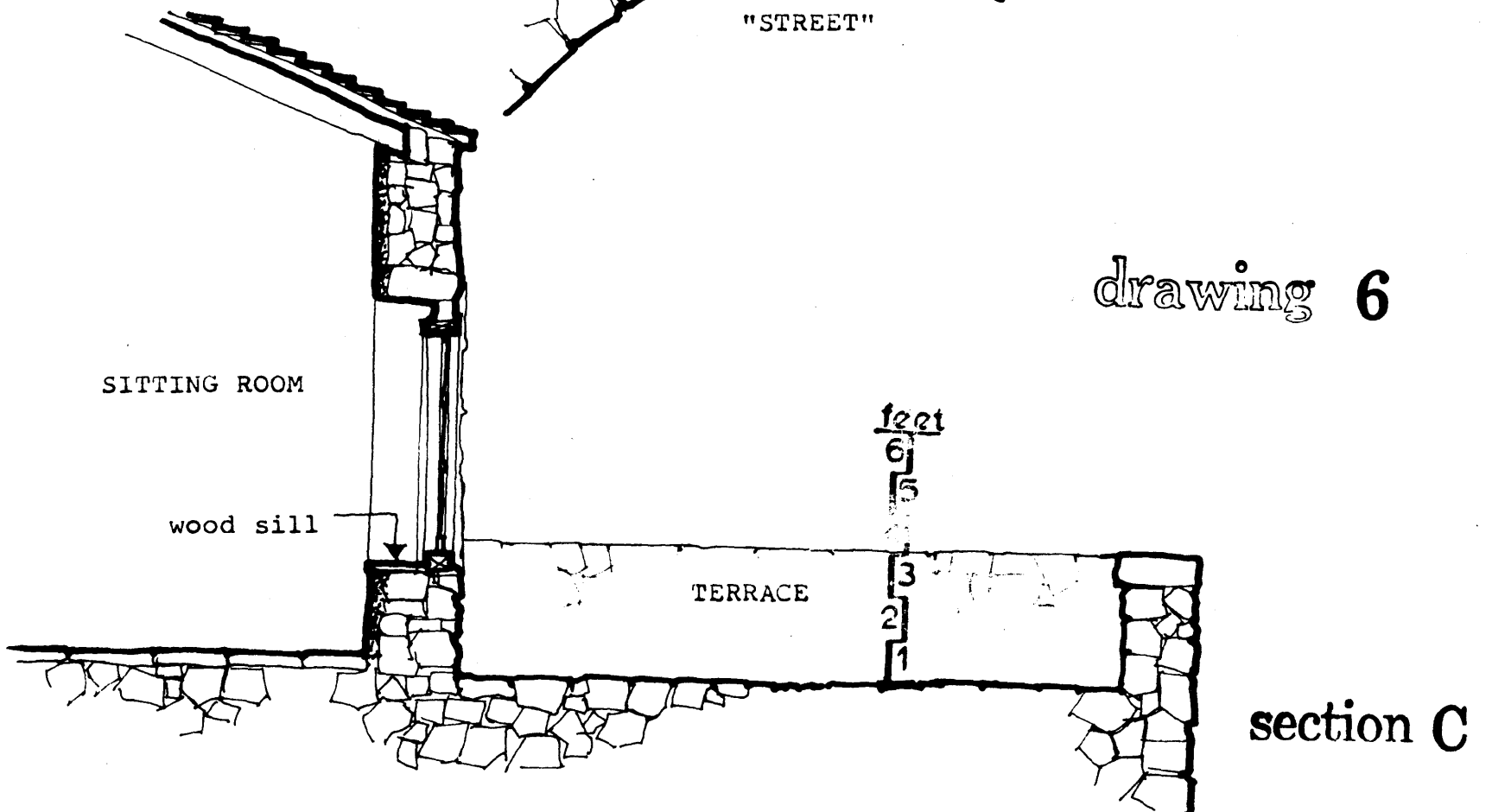
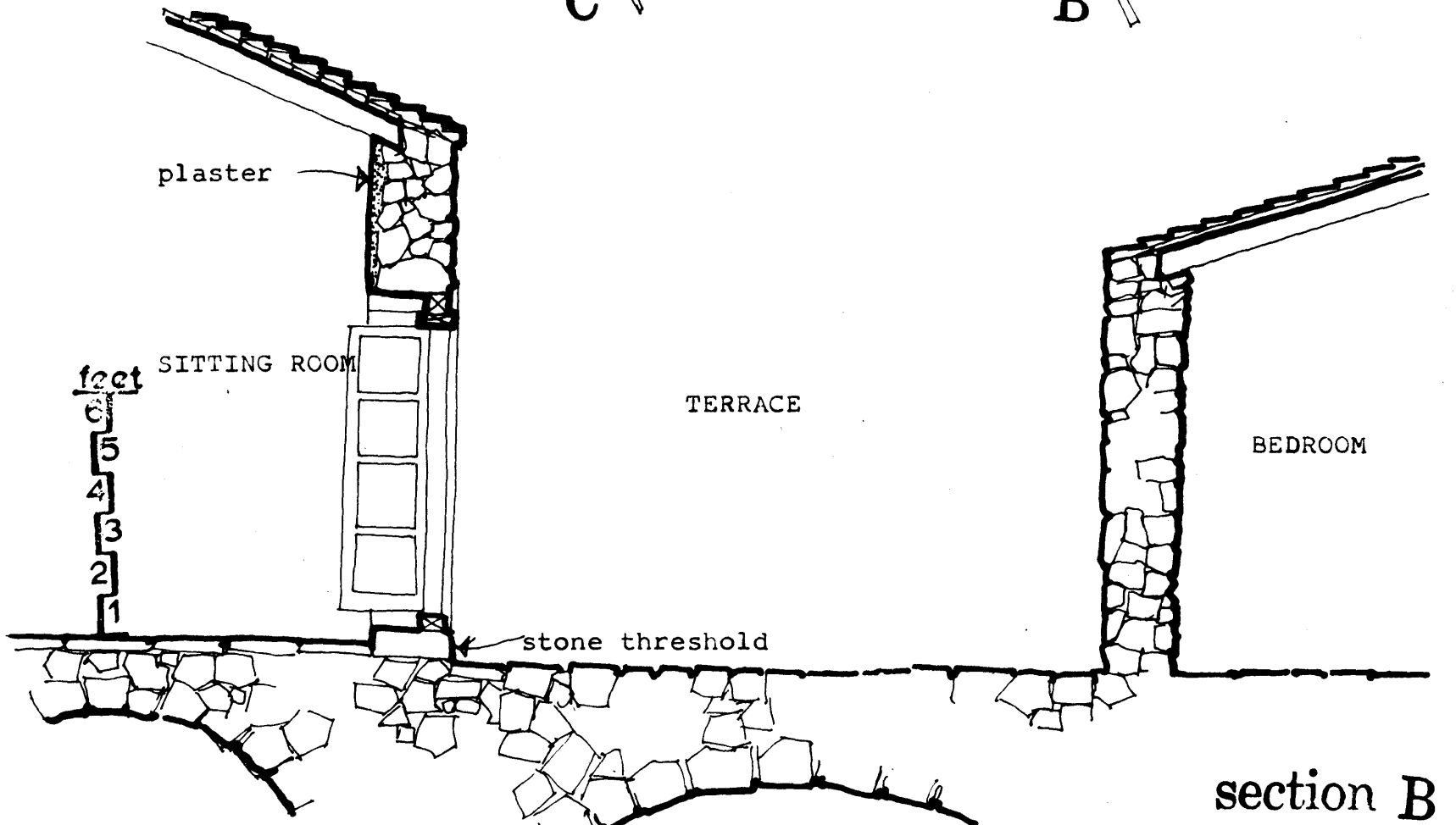
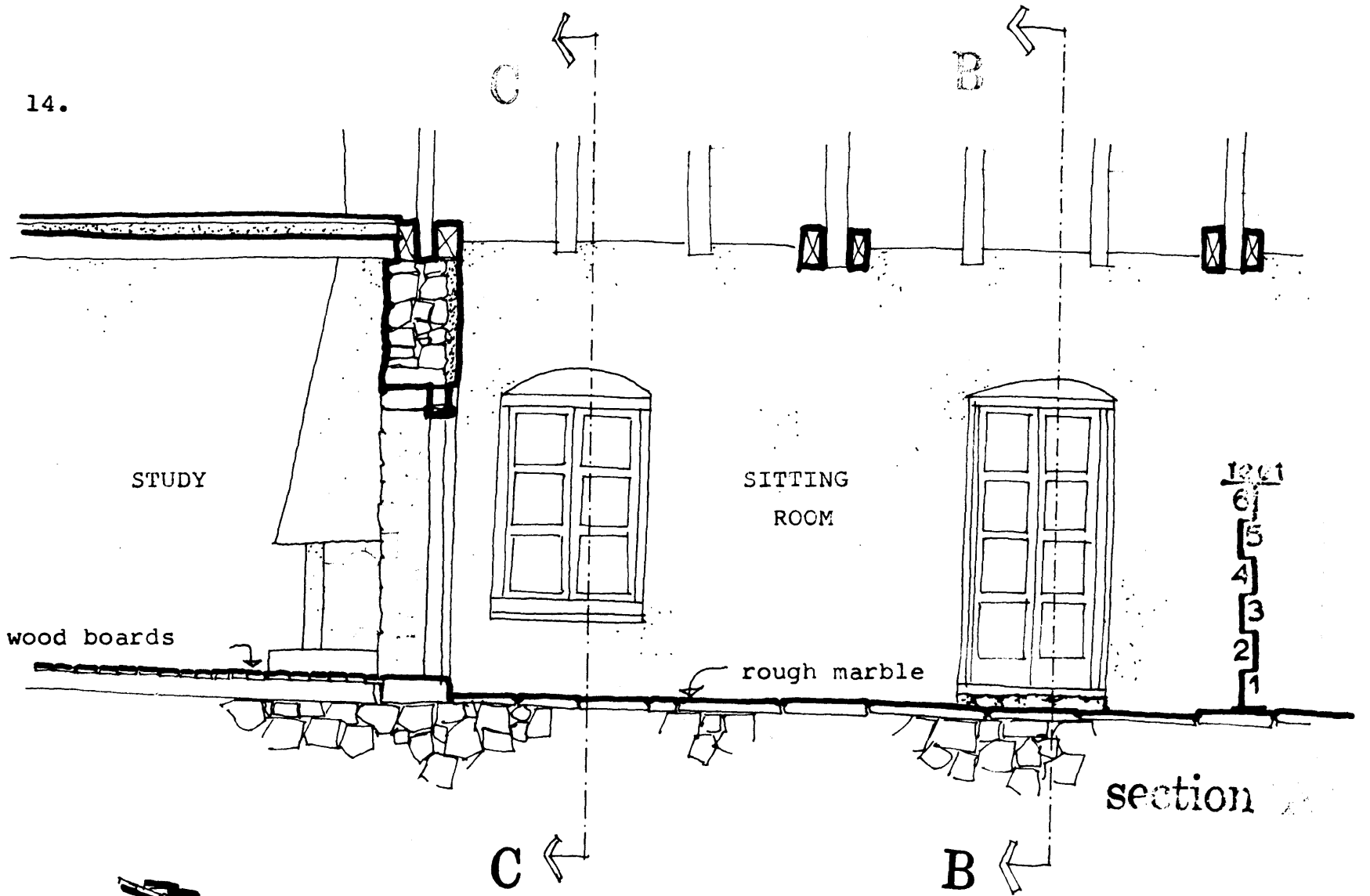

drawing 6

drawing 3-6

associative form

1. In stone houses, openings in a wall are usually sufficiently deep that the openings become spaces within the wall. Windows and doors can be operated within these spaces and intrude little into adjoining spaces. Surfaces with these opening can be given special treatment to indicate more particular use. In drawing 6, section C, the wooden window sill becomes associative as a table/shelf within a room that is primarily plaster and marble. The raised stone threshold of the door in section B serves to increase the division between the terrace and sitting room. The threshold creates a special use zone: step up-step down , stop-go. In section A the raised threshold between the study and sitting room identifies a higher floor/use level, that of the study.
2. As a stone construction, the terrace becomes an elevated ground form. At almost equal height as the sitting room, the terrace is used as an outside room. This room/space is more completely defined between the sitting room and the bedroom, section B. Here a roof trellis would make an open room.
3. Construction of the fireplaces in both the sitting room and study are taken as opportunities to construct use surfaces/spaces as part of the continuous surface room form. In context of the building system, these surfaces are minimal. More appropriate is the rough stone partial wall defining one side of the sitting room, forming a useful shelf.

comments

1. Given heavy masonry construction, the opportunity exists to create use spaces within the depth of the wall. Such spaces can relate, be associative, to either side of the wall.
2. Given sufficient dimension, ground and elevated, terraces and balconies can be used as external rooms/spaces. These spaces can be related to private internal spaces more directly than public spaces to internal spaces.



drawing 7

House Front, Former Shop

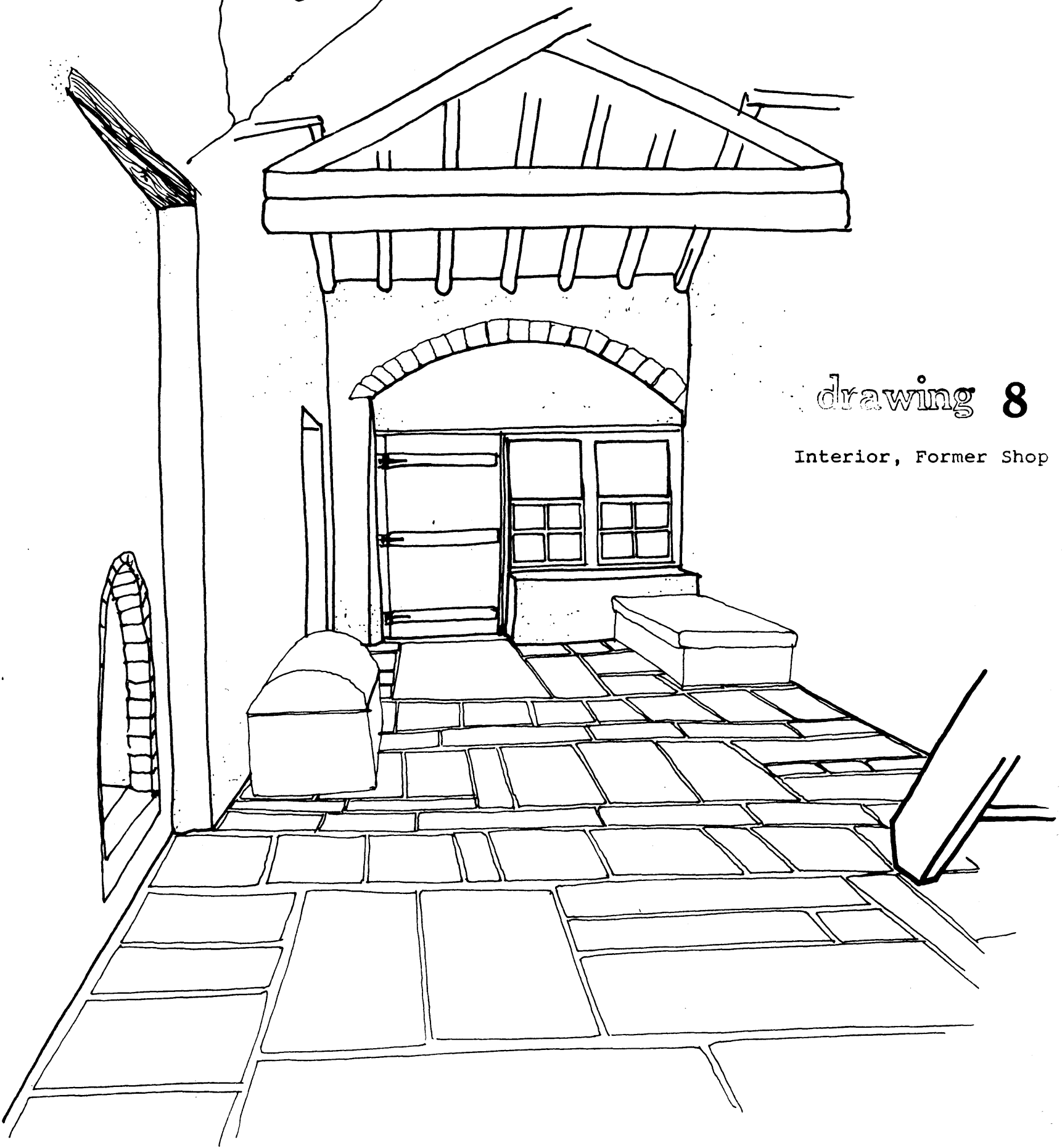

drawing 8

Interior, Former Shop

drawing 7-9

associative form

1. Shown in section, shutters/awning and stone ledge build a spacial edge along the street. The shutter overhead allows a person/object in the street to be partially/minimally within the zone of the house. Windows, door, and floor ledge/curb are a barrier to entry/association with the interior and vice versa. The large stone table increases the distance the public zone enters the room, forcing living functions further from the window/door zone. This edge/zone along the street is variable in association due to the degree shutters, windows and door are open.
2. The interior floor level extends to the street as a curb. It is identifiable as the interior use/private level and is associative as a separate use level from the street. Further, the raised floor protects the private level from street dirt, water, wear etc. and may be associative as a level protected from the street.
3. Identifiable as a built opening, the stone arch over the windows is unplastered. Since it can be seen as a structural element it defines the depth of the bearing wall within the spacial edge/zone.

Comments

The design indicates how association with the building edge can be extended to become a zone of spacial definitions.

20.

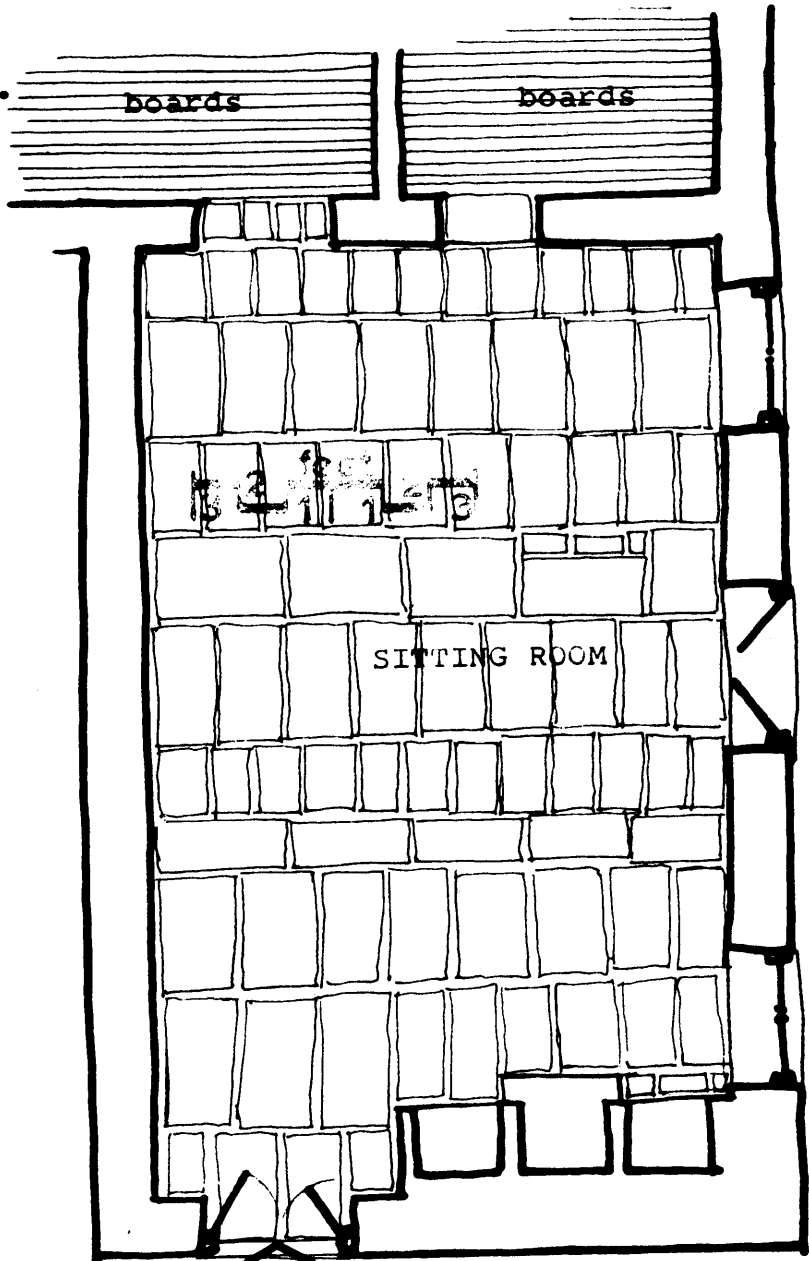

TERRACE

drawing 10

Rough Marble Floor
Directional

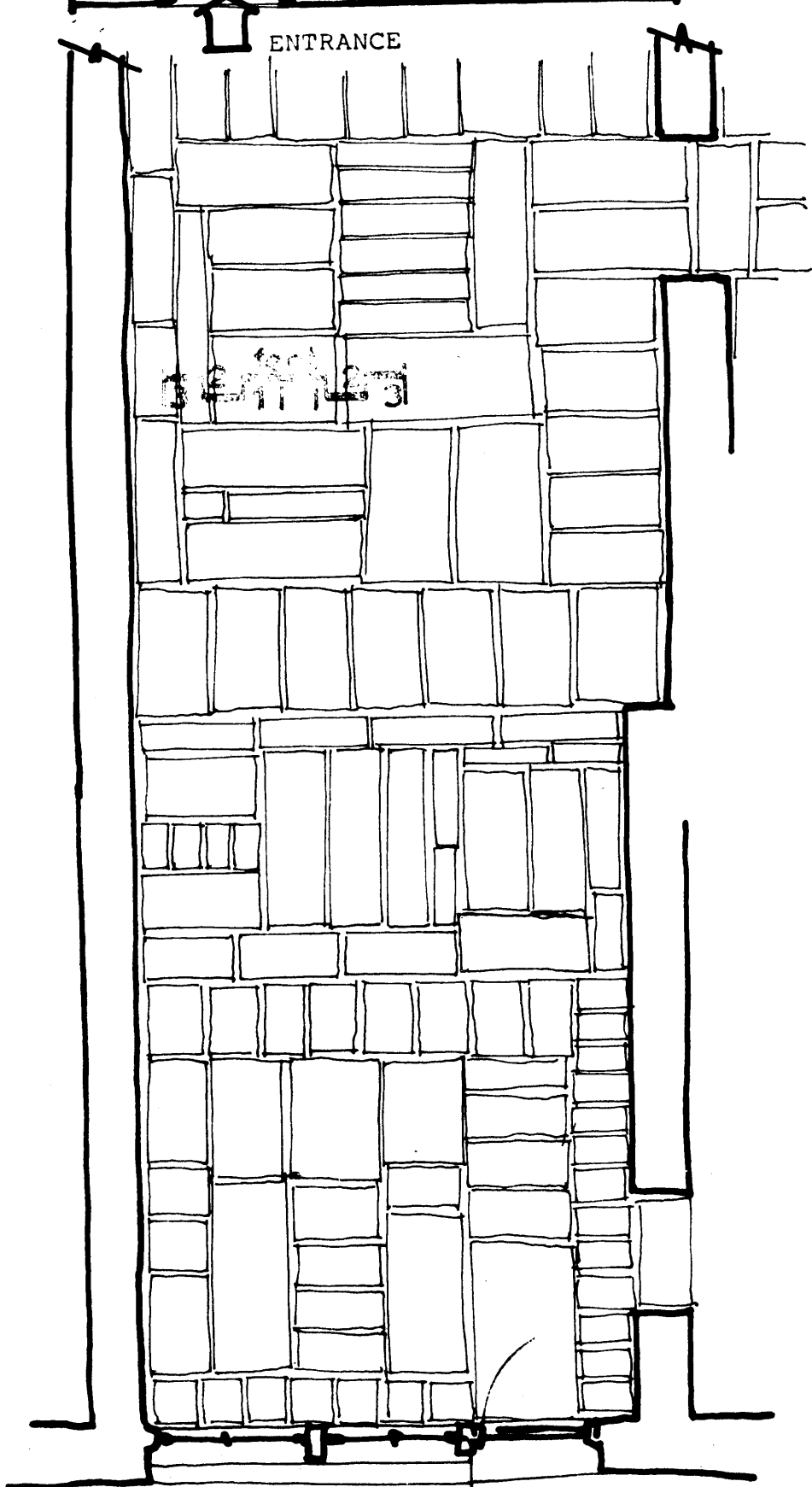

drawing 11

Rough Marble Floor
Multi-Directional

drawing 10 - 11

associative form

1. Shown in plan, rough marble floor patterns can be directional and associative to their boundary definitions. In drawing 10, the pattern is additive from the entrance to the rear of the sitting room: row added to row added to row. This becomes associated with walking: step after step. This therefore gives the floor direction relative to the associated movement. To right angles of this additive direction is also a direction indicated by addition of stone after stone. However, in this direction association/relation is to only one row of stones, movement/attention being channeled along one row. Lateral movement in this cross direction is less associative to the floor pattern. Note that the individual stones are 1-3 feet in dimension, closely associated with the area required for standing.
2. In the pattern illustrated in drawing 11, many directions are evident. Some of these directions turn several times and close on the original direction. This creates places within the pattern. Doors, Windows, jogs in the wall are utilized to change direction or indicate a special place in the pattern.
3. Change in size of the stones creates areas of interest. Smaller stones introduce discontinuities in an overall pattern of larger stones, easily drawing attention to that area.
4. The pattern of floor boards in drawing 10 is similar to that of the adjoining stone floor. The additive direction is the same, crossing the narrow dimension. To right angles attention is drawn along the length of the boards to the side walls. The board pattern differs from the stone pattern in dimension. The 3-4 inch width of the boards is not directly associative to the sizes of people

comments

Although not a spacial form, floor patterns allow association with direction of movement or direction of attention, reinforcing the total spacial definition.

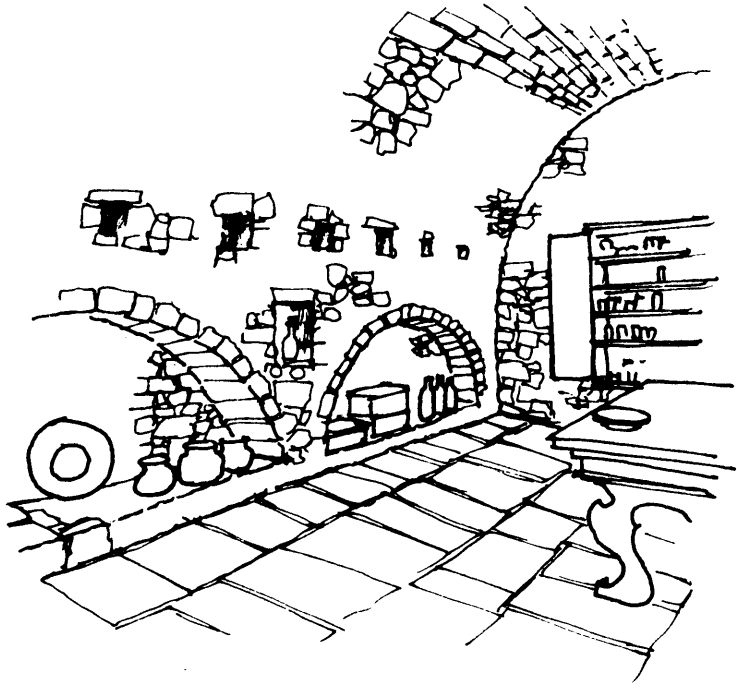

drawing 12

House With A Balcony
Kitchen

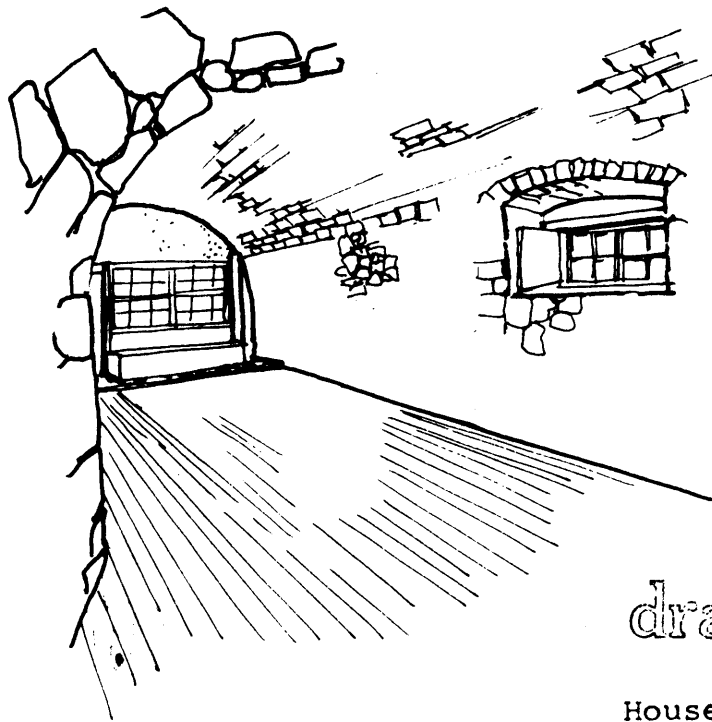

drawing 13

House With A Balcony
Bedroom

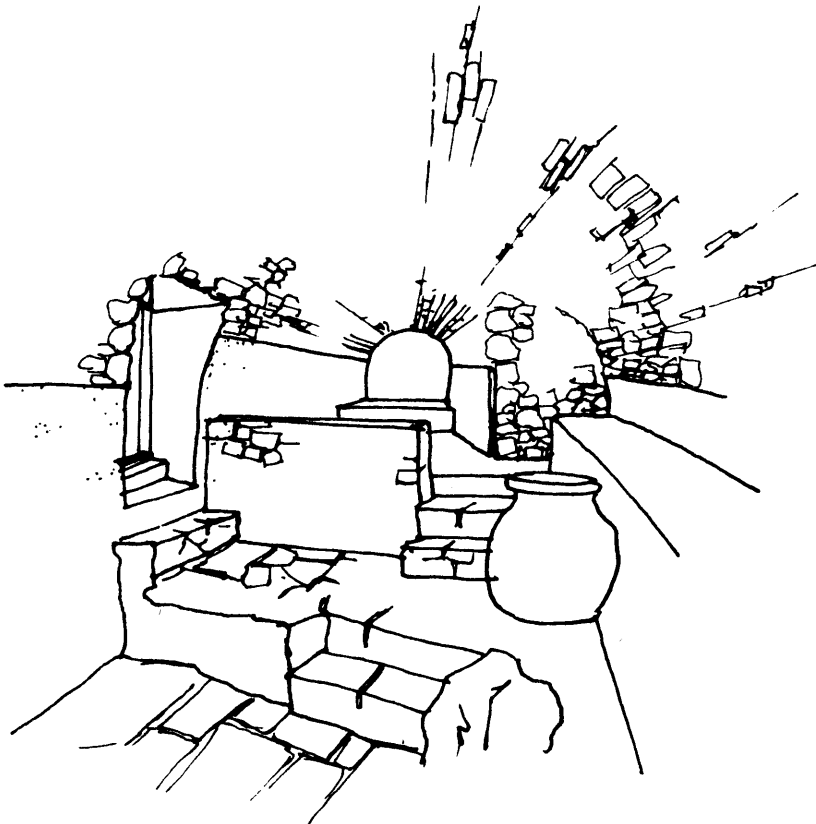

drawing 14

Storage Vault

drawing 12-14

associative form

1. Vaulted ceilings give rooms a strong movement direction along the vault. The form would seem to continue endlessly as if it were a part of a tunnel. Note in drawings 12 & 13, floor patterns are additive across the axis of the vault, directing attention/movement to the sides of the vault.
2. In the vault in drawing 14, the ground form creates multi-directional use surfaces defining many spaces within the singular vault form.
3. In all drawings, doors, openings, and windows placed along the sides of the vaults direct attention at right angles to the strong movement direction. The association being: Stop-here/place.

comments

As an arch form, the vault is associative as a continuing opening to be moved through/along. Stopping attention/movement within this form can be done by associations at right angles to the vault. Attention/movement can also be stopped by changing direction or defining spaces with the ground form.

As a generalization, rectangular rooms with ceilings higher than their width can have associations similar to those of a vault.

Note several such rooms in drawings 8, 17 & 19.

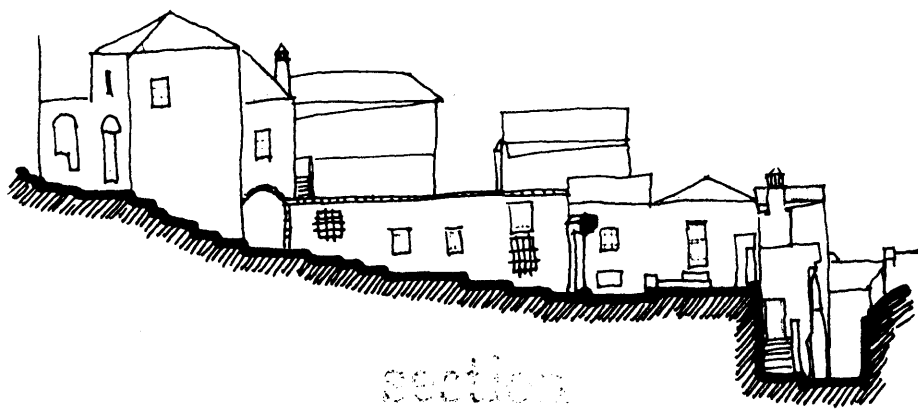
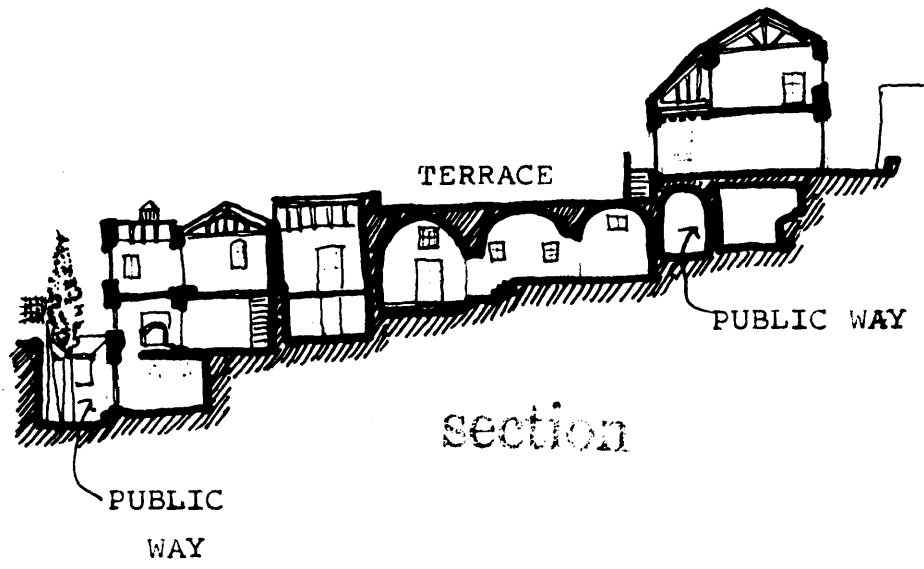

drawing 15

Houses On Market Street

drawing 15

associative form

The sections in drawing 15 indicate exterior ground form and the related interior built spaces. Level changes in the built form occur by room with larger area floors occurring on the upper levels. Some larger spaces on the ground are obtained by filling over original ground level then extending that level as a floor over the next lower level.

Association with the first levels of these houses provides a sense of the exterior ground levels. When upper floor levels are reached association is no longer with the ground but with relative levels/spaces/privacies.

Comments

1. Given an interesting terrain, interior spaces and relationships can allow association with the exterior ground levels.
2. Given a flat site, it is conceivable that lower floors could have large areas at one level and by varying ceiling/floor heights provide a variety of upper levels and relationships.

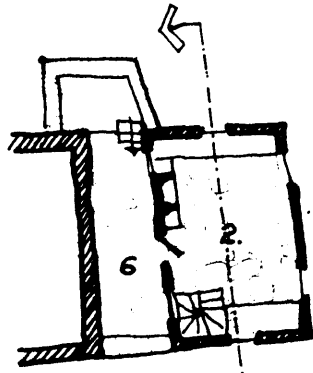

plan
First Floor

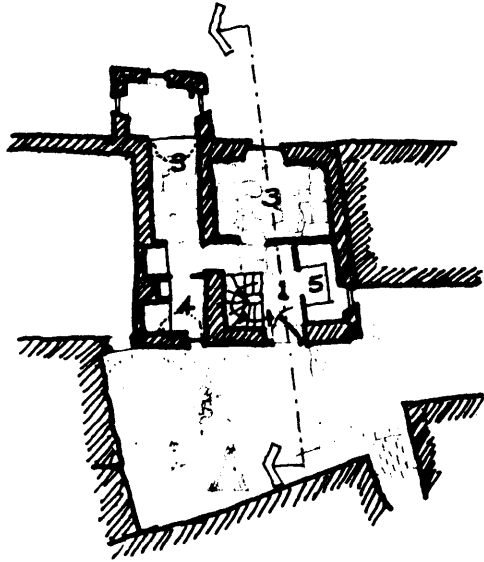

plan
Ground Floor

- 1. ENTRANCE
- 2. LIVING ROOM
- 3. BED ROOM
- 4. BATH ROOM
- 5. KITCHEN
- 6. TERRACE
- 7. VAULT

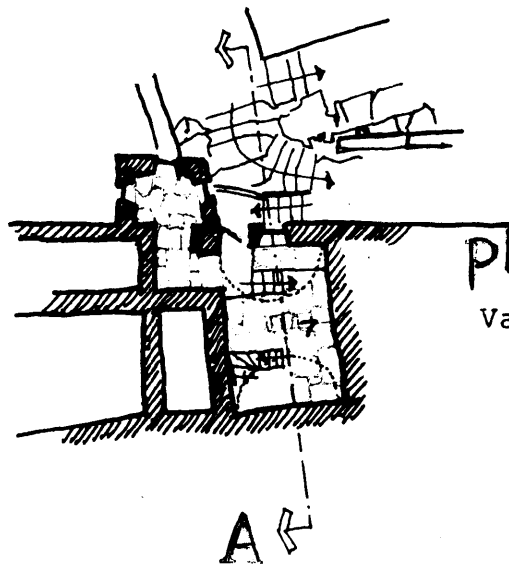

plan
Vault



— meters



section A

drawing 16

House On Market Street



drawing 17

House On Market St.
Living Room

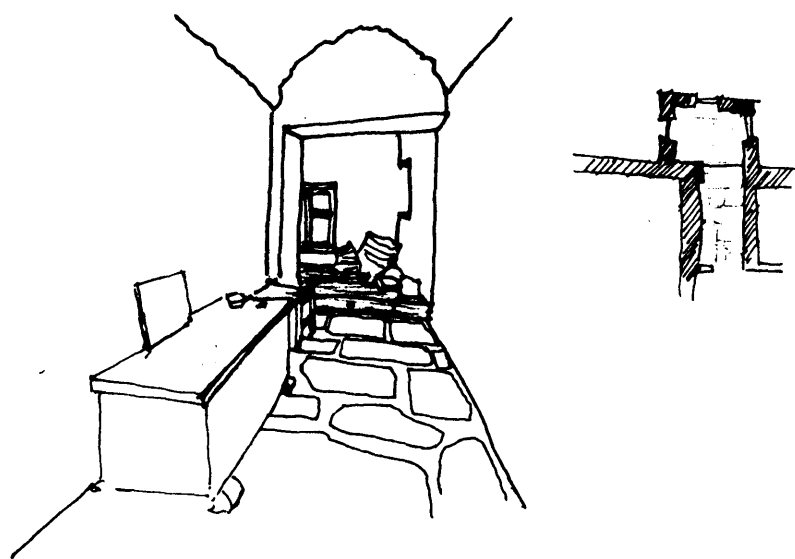

drawing 18

House On Market St.
Bedroom

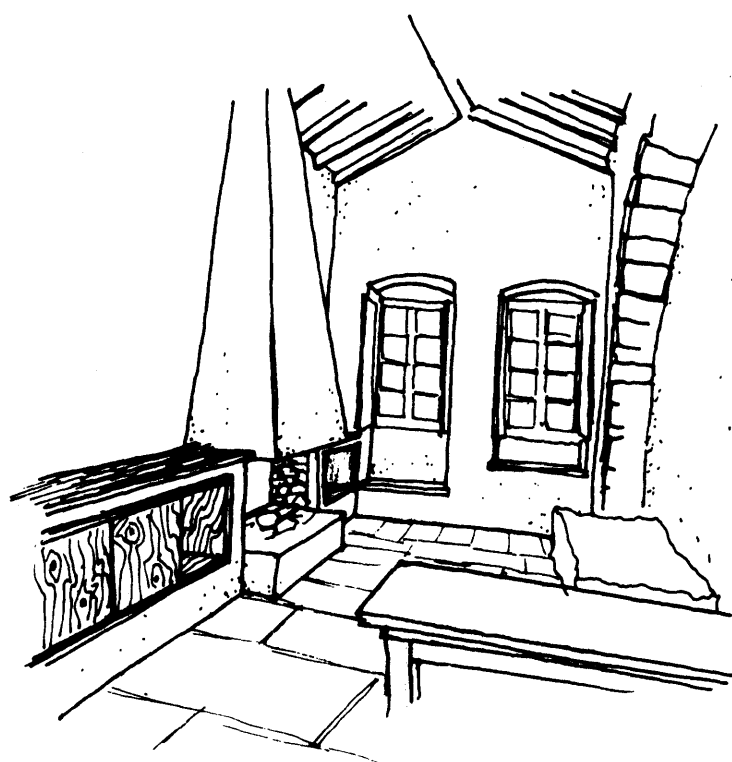

drawing 19

Living Room

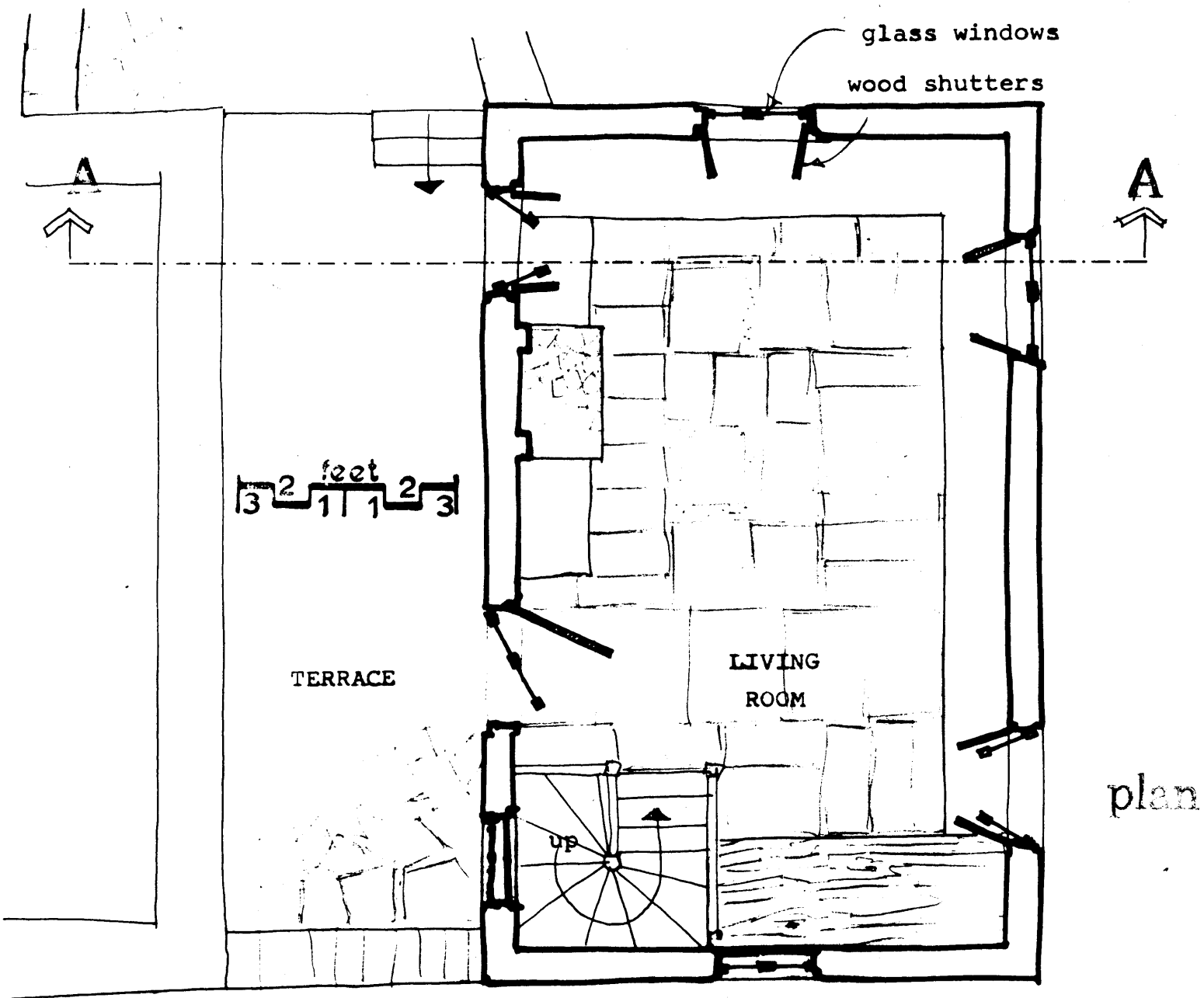
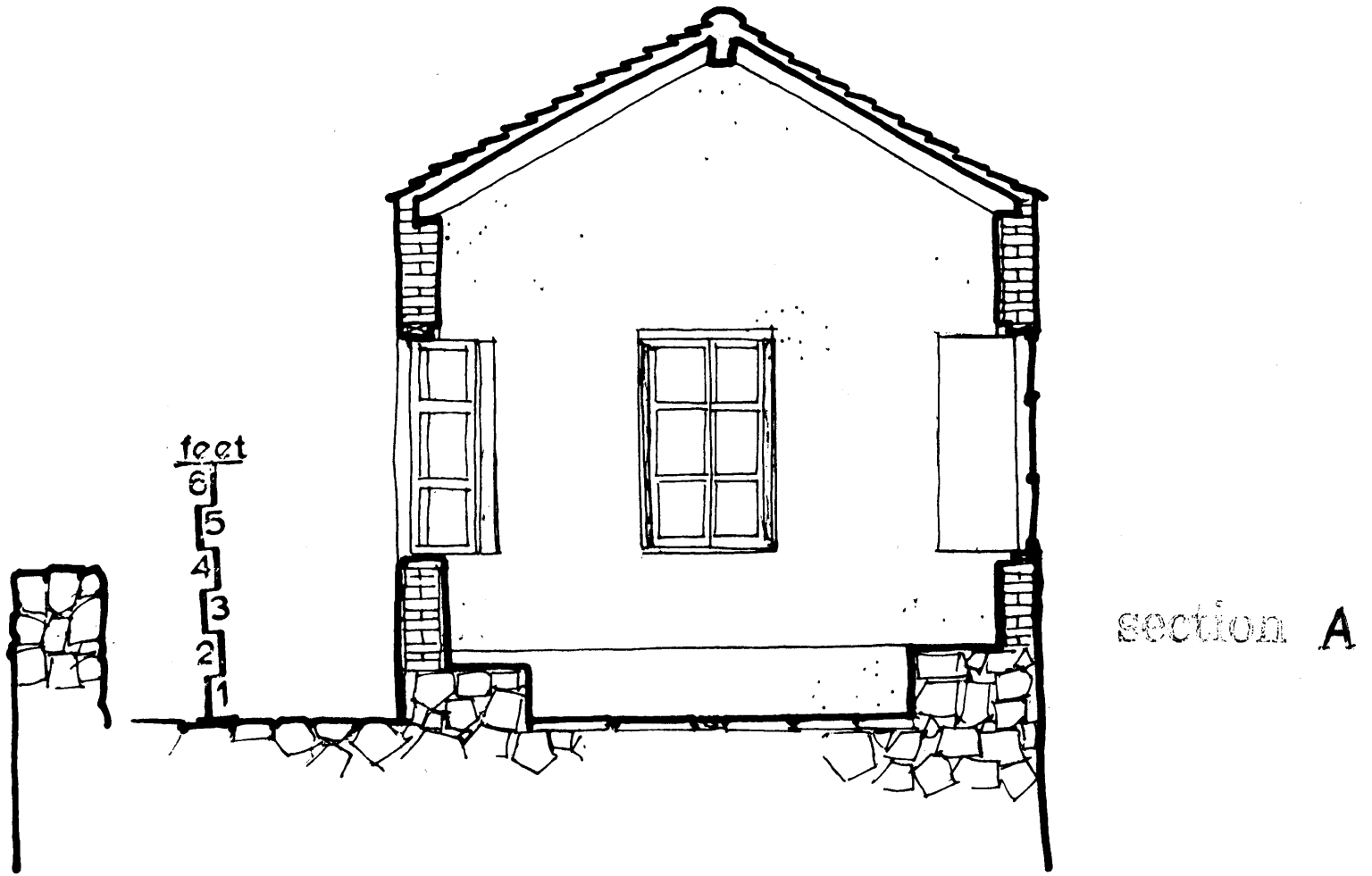

drawing 20

House On Market Street
Living Room

drawing 16 - 20

associative form

1. Drawn in section, thin , lightweight walls allow older stone walls to be used as seating around the room. Attention is directed centrally in the room. Windows high on the wall, add to the intentional enclosure and serve more to let light in rather than to direct attention outside.
2. Because of the relative width and length of the terrace, movement is along the length. As a result, the ends of the terrace become more useful for stopping due to the placement of the door near the middle of the terrace.
3. Note in drawing 17 the gabled ceiling gives the room similar directionality to the vault form. Strength of this directionality is reduced as the ceiling is lowered and the room made wider perpendicular to the ridge axis.

Comments

1. Where different building materials and techniques meet in buildings, various use surfaces can be defined depending on the relative sizes of the materials.
2. Directionality of a room can be reduced by making the plan of the room nearly square and lowering the ceiling till it is lower than the width of the room.

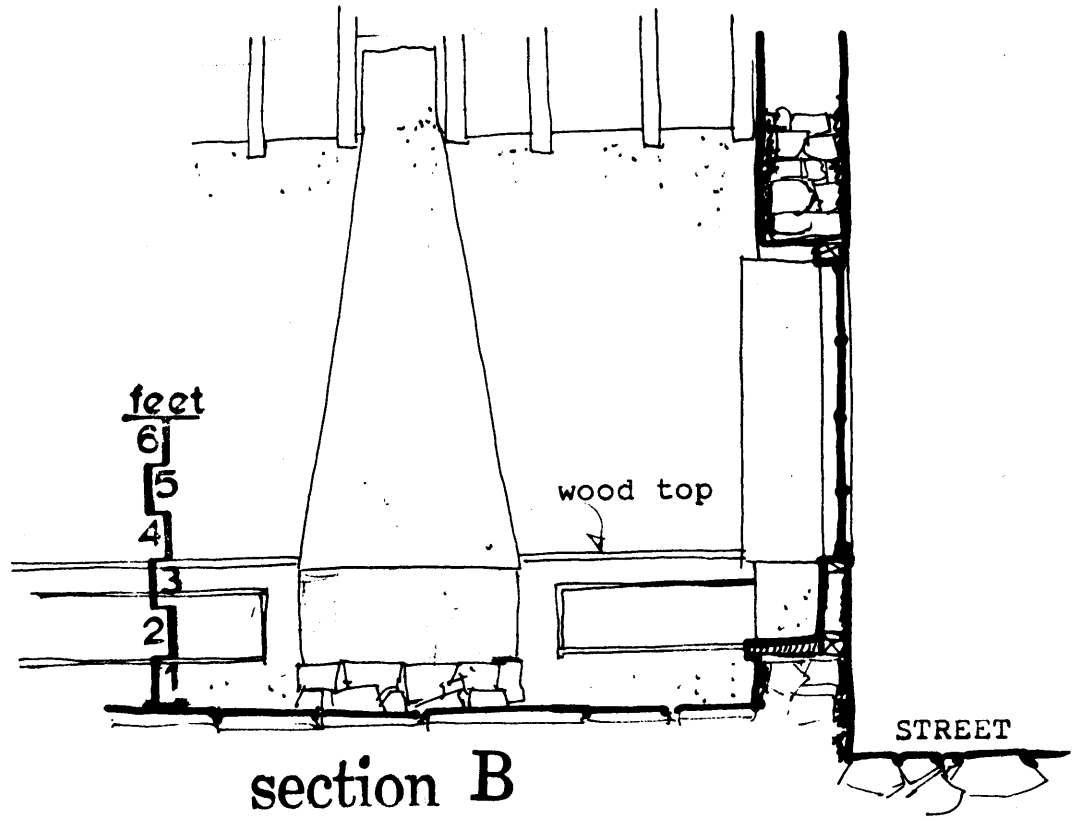
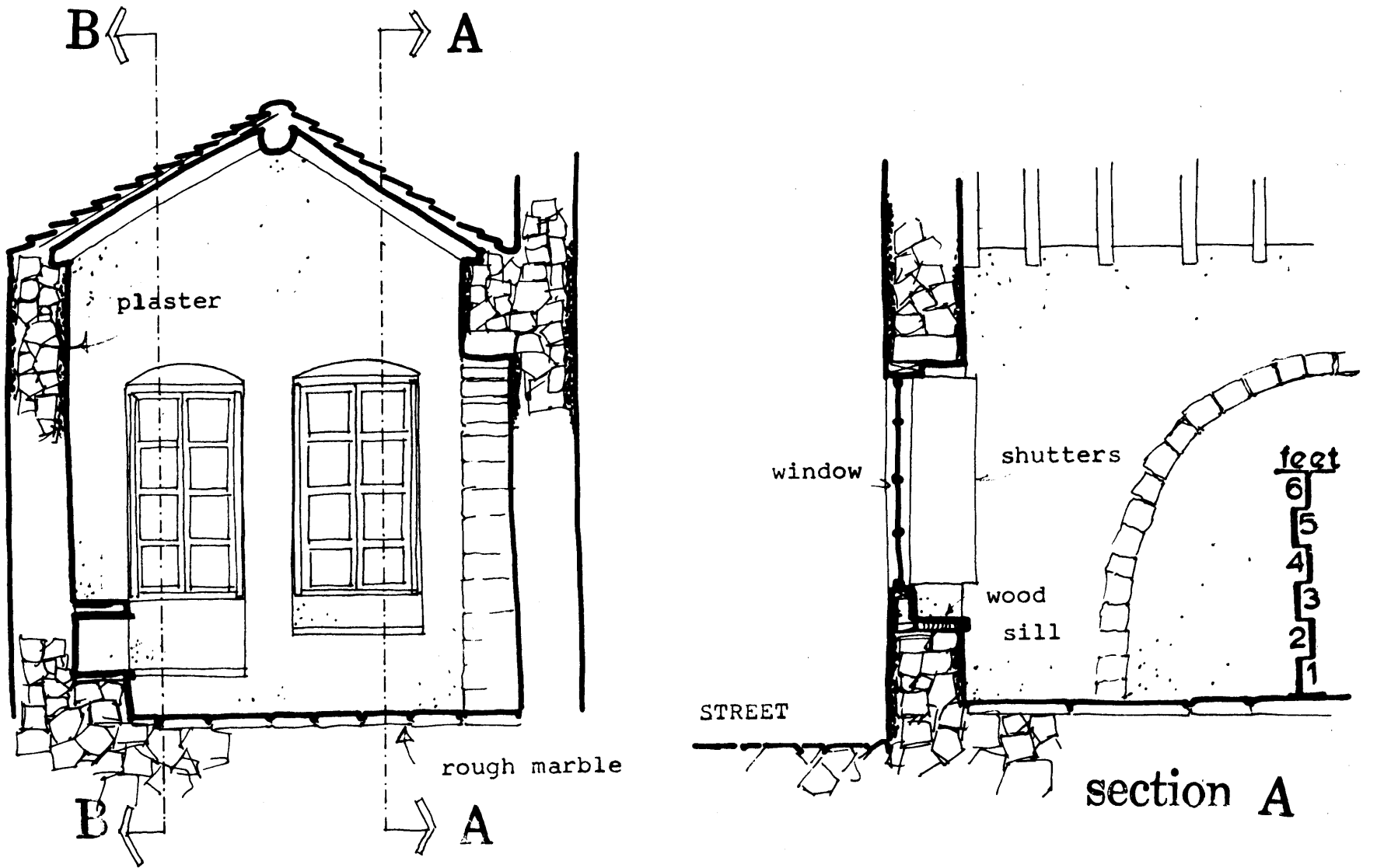

drawing 21

Living Room

drawing 21

associative form

1. Sections A & B in drawing 21 show that the depth of the wall contains windows, their operating zone, and use surfaces associated with the activities of the adjoining space. The window sills are lowered sufficiently to allow sitting on the sill or placement of objects without interfering with window operation.
2. Limited use of wood as window sills, cabinet tops, cabinet doors, and shutters increases the association with these particular definitions: wood/warm/soft vs. cold/hard/plaster.
3. Although minimal in depth, the archway recess in the wall defines a partial space whose direction of attention is perpendicular to the ceiling ridge line and room direction. The recess defines a use area within it and in the near vicinity.

comments

1. When walls and openings are of sufficient depth to be identified as spacial zones, these zones can accomodate various uses and definitions in addition to window units.
2. Selective use of materials for various use surfaces increases the association with these surfaces as to intended use.
3. Recesses in wall surfaces, even if minimal, define a region of spaces associated with the zone of the wall.



drawing 22

Hanging Houses
Cuenca, Spain

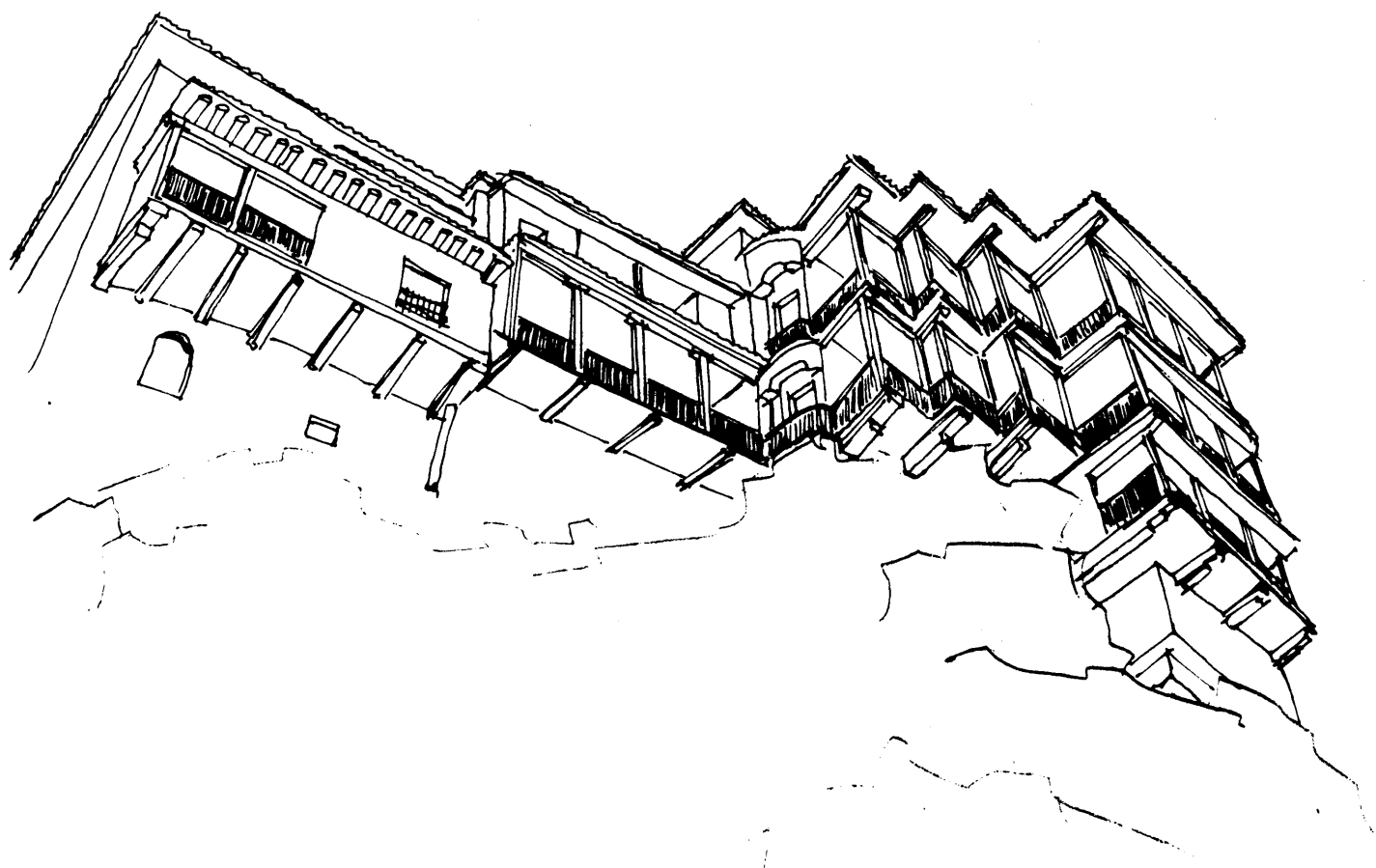

drawing 23

drawing 22-23

associative form

1. Stone/masonry walls responding/associating with changes in rock cliff forms define habitable spaces on the order of 5-20 feet. Larger definitions are obtained by addition of more units of similar size.
2. The entrance court/distributor is defined by various masonry walls of smaller dimension than the overall court size. The court is partially enclosed by surrounding walls and is a void in the built form surrounding. The simple wall openings/windows direct attention through these windows toward the court. This is in contrast to the open framework balconies which allow attention to be focused 180 degrees. Notice that the balcony adjacent to the entrance court allows association with both the court space and the space beyond the cliff.
3. Open framework balconies allow persons to get into and associate with spaces external to the masonry walls. The open supports and railing allow a 180 degree view. Because the balconies are built on the masonry walls, each has a particular association with the other balconies and walls and, therefore, produces a variety of views and privacy interrelationships.
4. A variety of framework balconies are built, each controlling the degree in which it is possible to enter/associate with the space external to the building:
 - Deep Balcony
 - Shallow Balcony
 - Window Ledge

Comments

The large variety of relationships in plan and section result from simple changes in plan of the masonry walls and simple changes in section of the balconies. A variety of window openings increases the individuality of each opening.

Habitable dimensions of 5-20 feet are maintained with continuous larger dimensions, 20-50 feet, present only in vertical walls. The system of balconies forms a spacial edge and allows access and association with the space beyond the cliffs.

34.

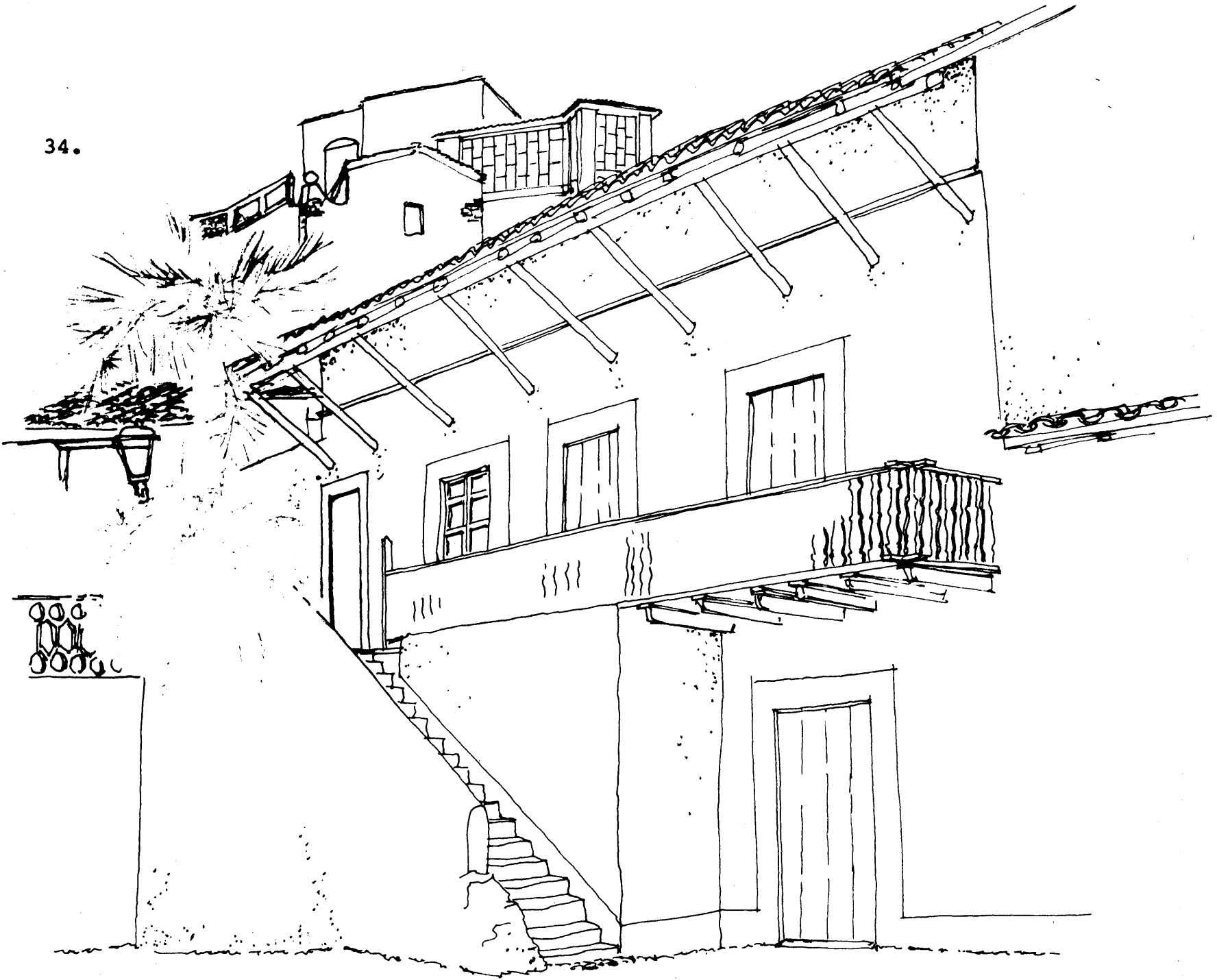

drawing 24

Balconies, Taxco, Guerrero



drawing 25



drawing 26

House of Shields

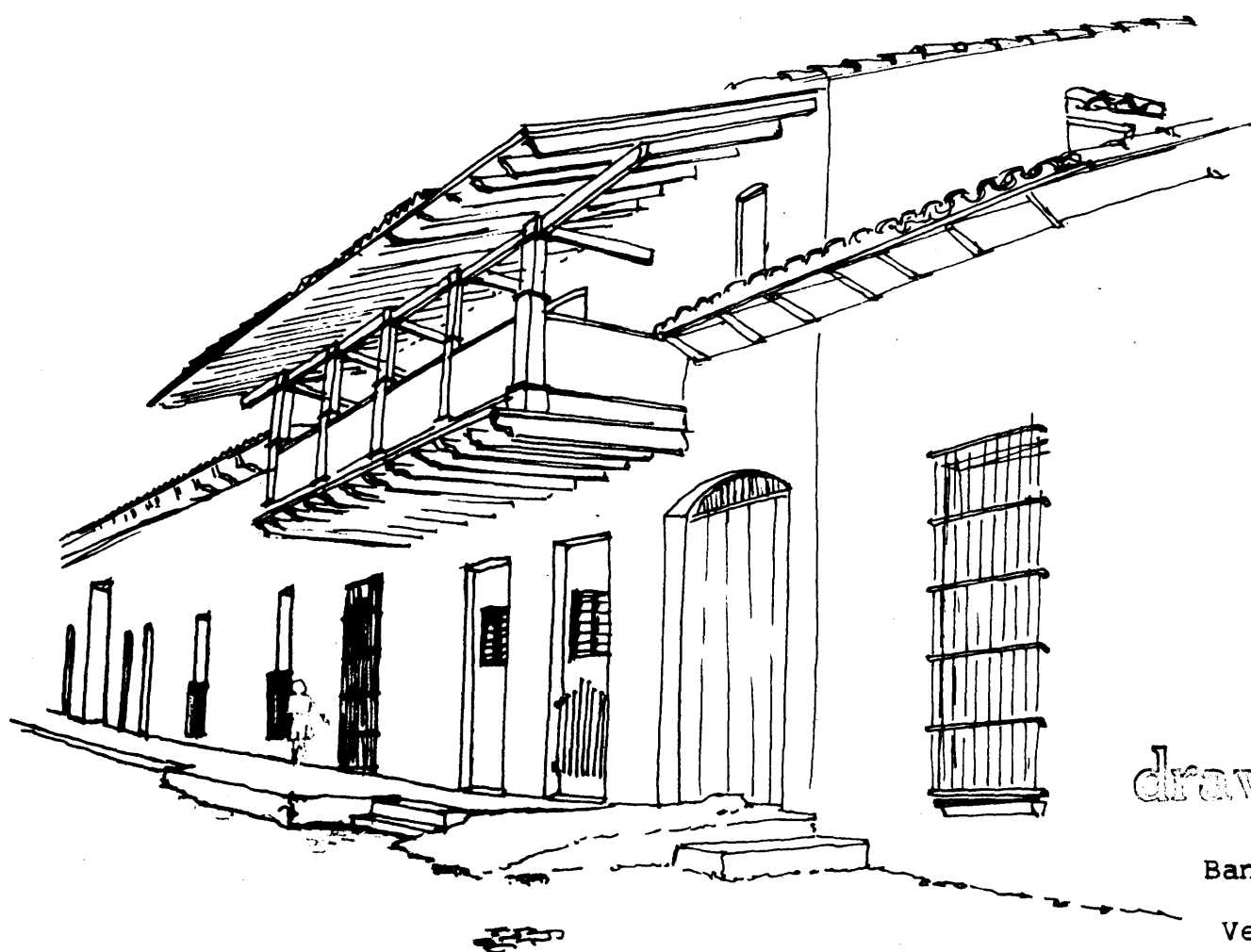

drawing 27

Banderilla,
Vera, Cruz

drawing 28

Enclosed Porch/Balcony

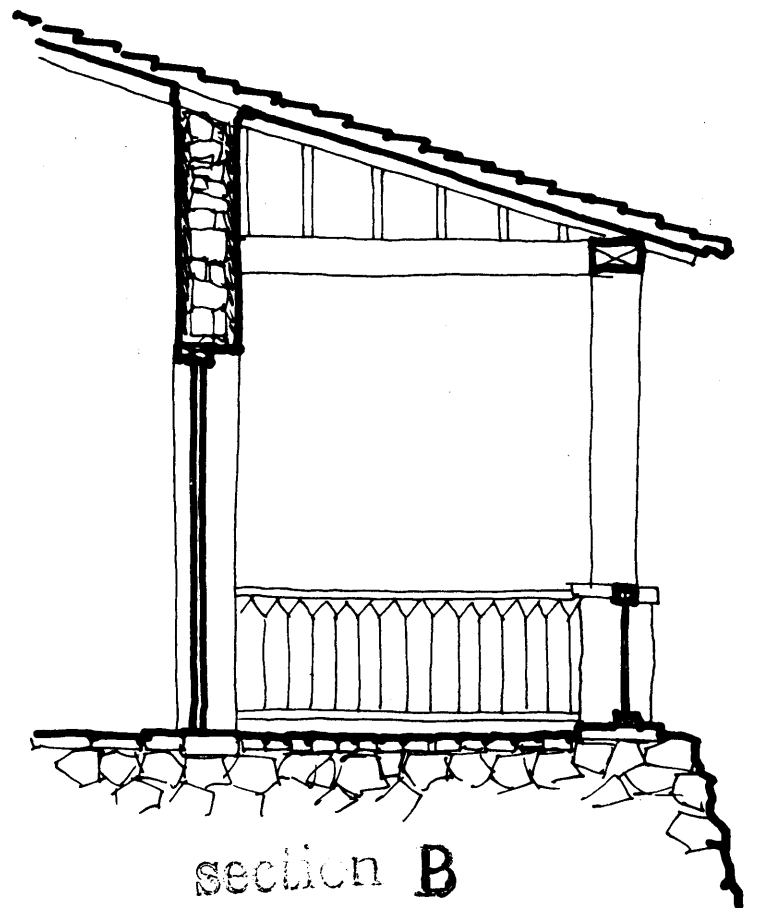
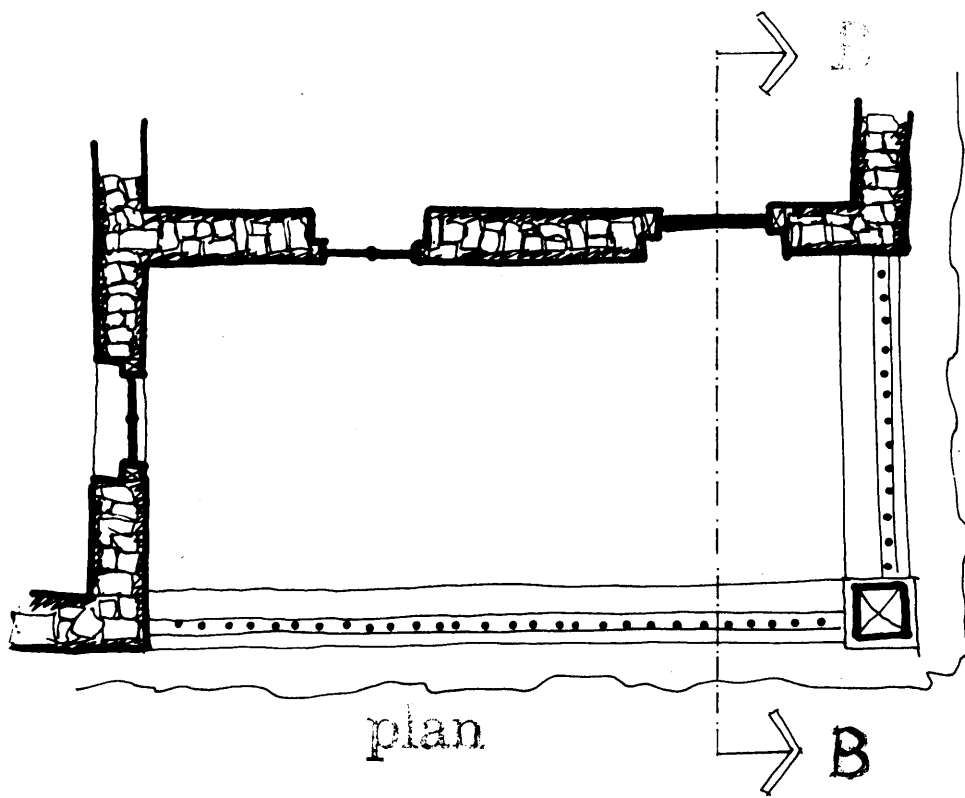
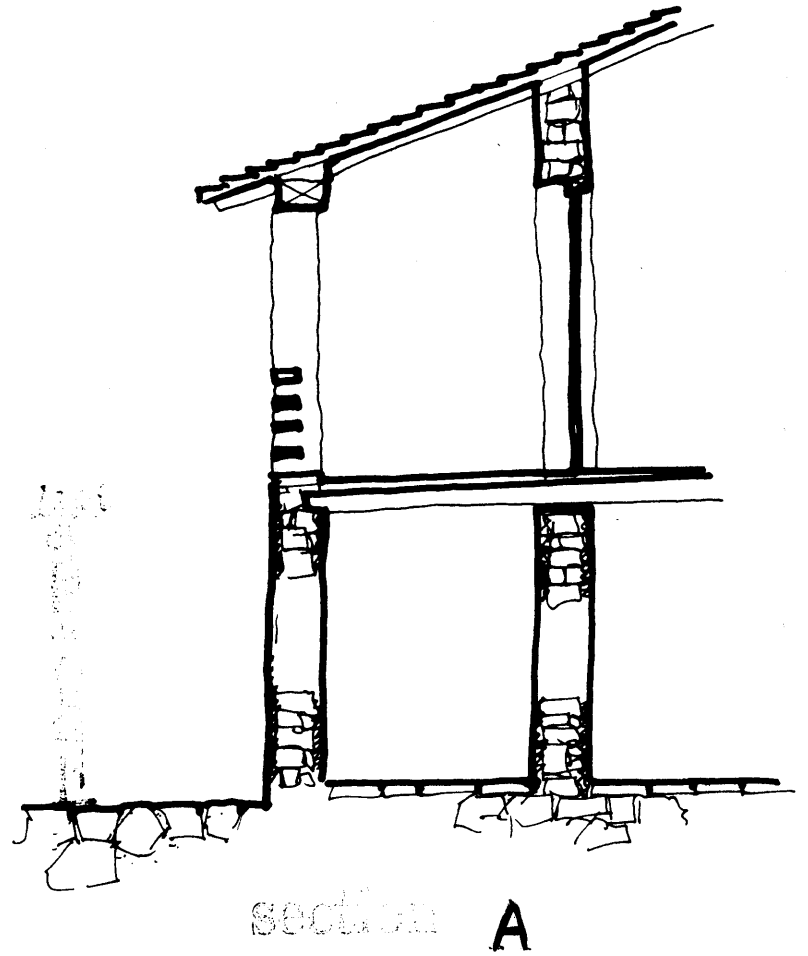
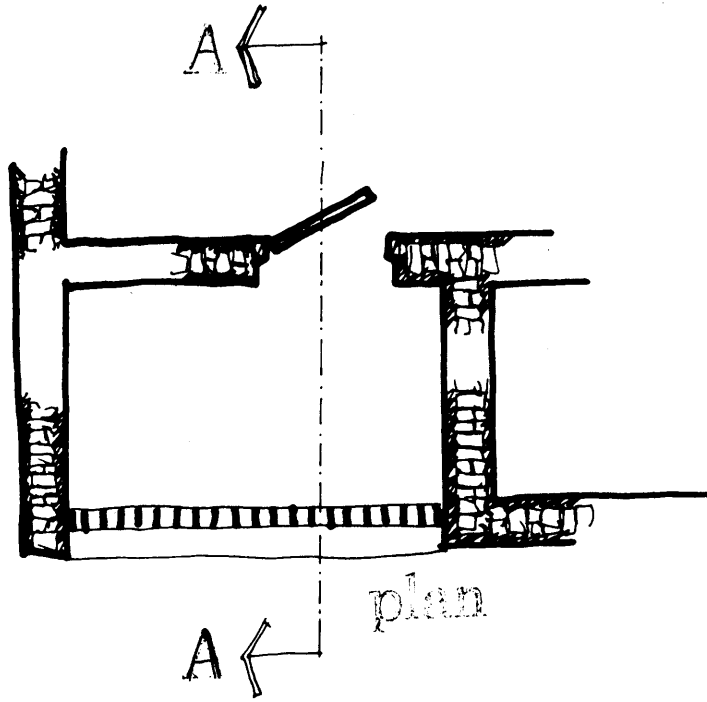

drawing 29

Open Porch/Balcony

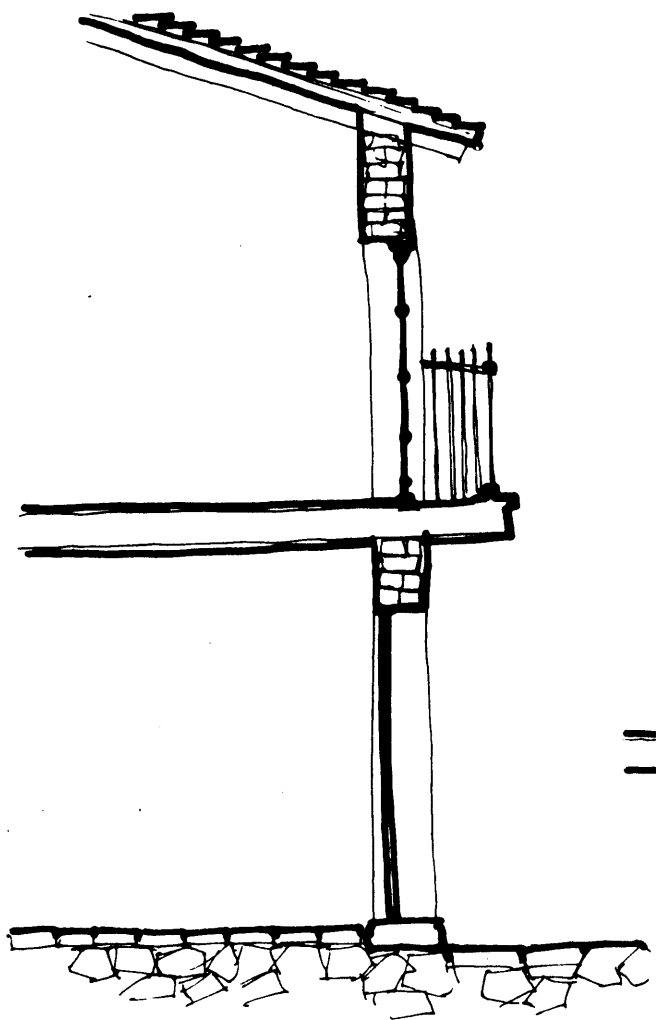

section C

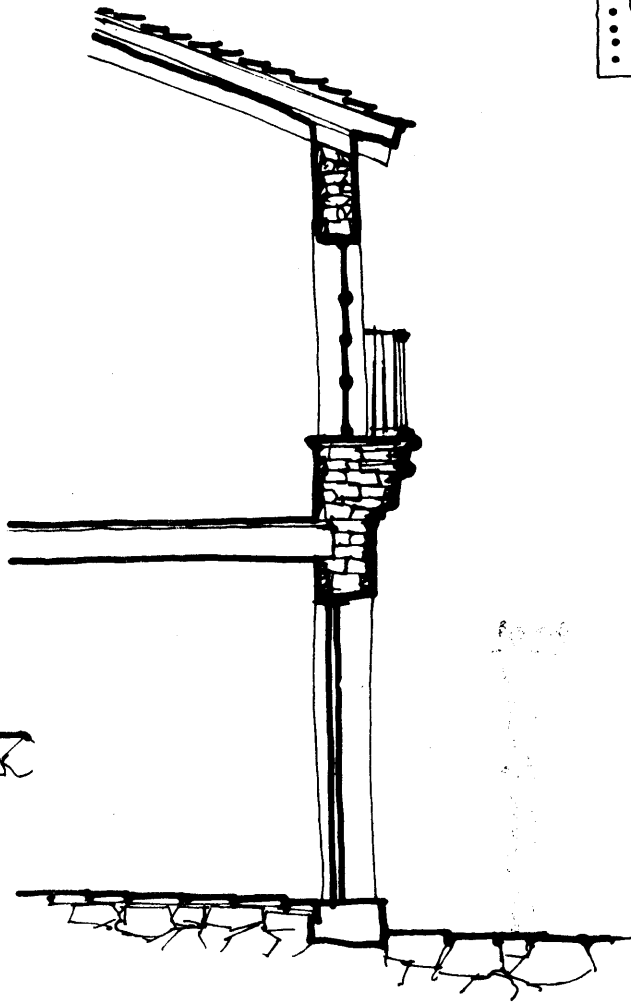

section C

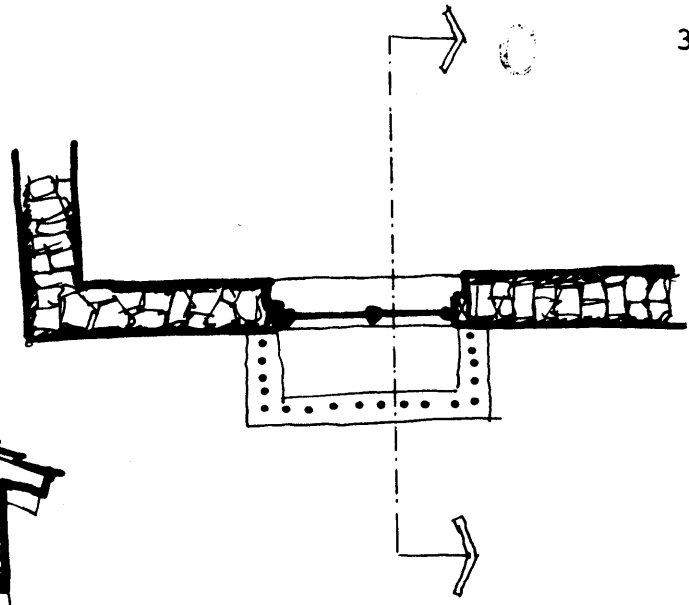

drawing 30

Window Balcony

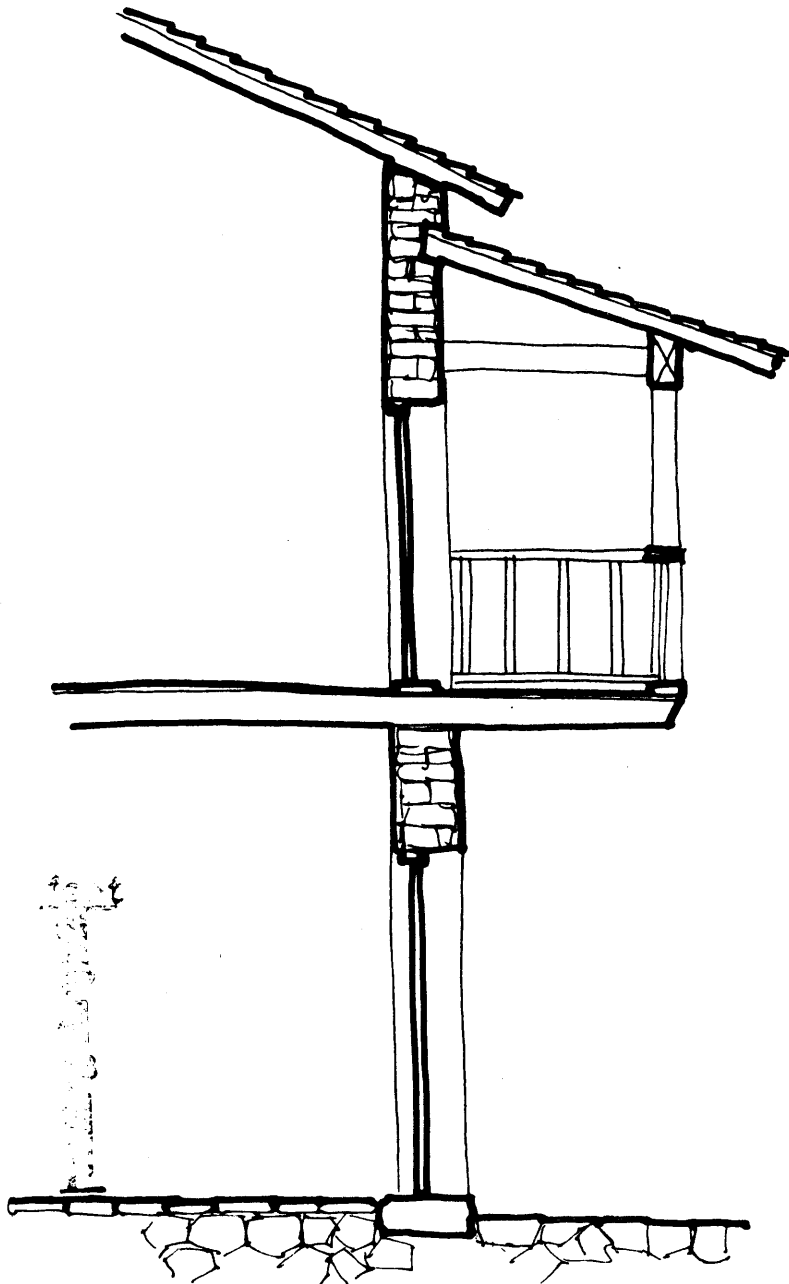

drawing 31

Cantilevered Balcony

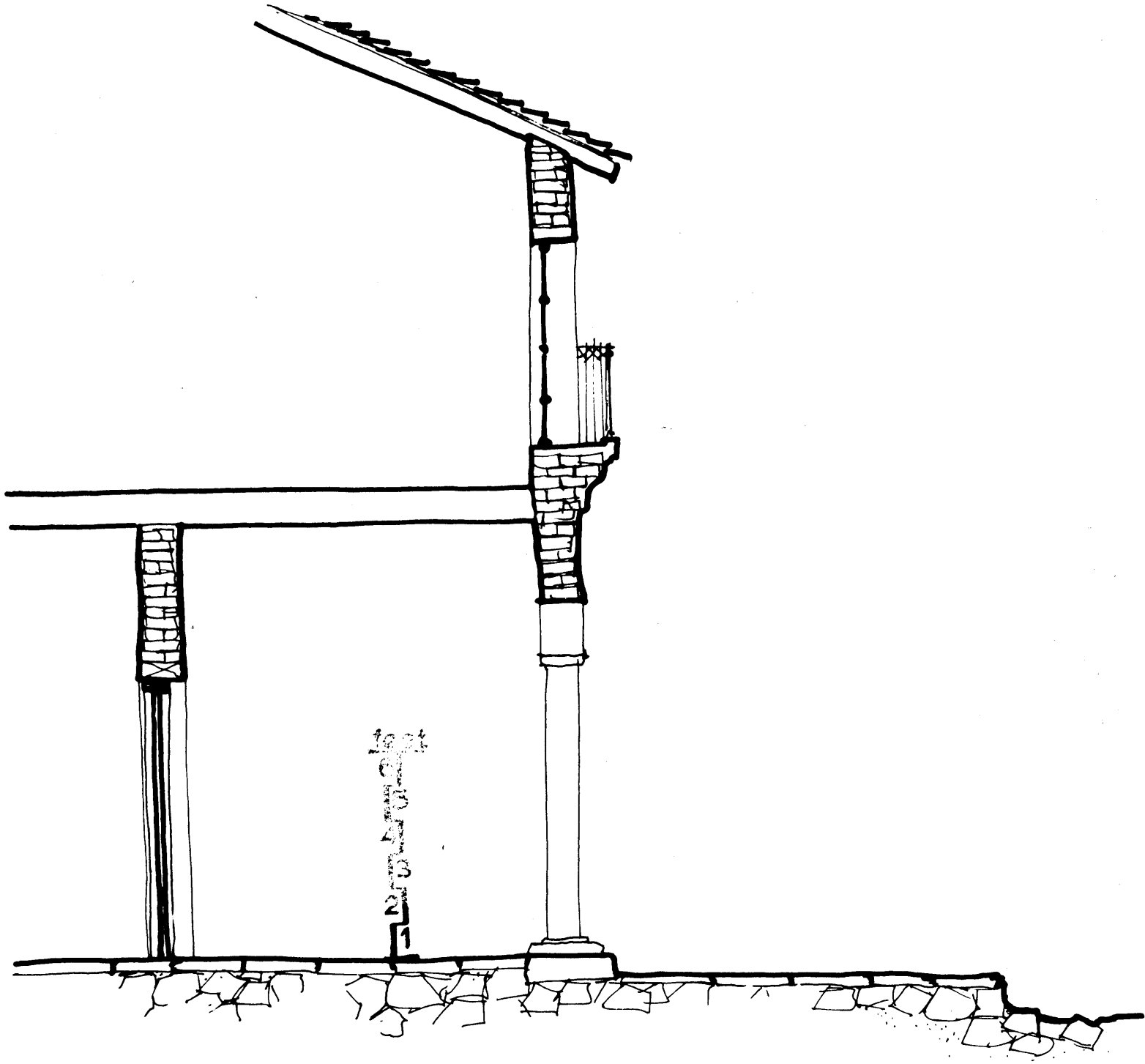

drawing 32

Supported Balconies/Enclosures

drawing 24 - 32

associative form

1. The closed porch in drawings 25 & 28 defines an open sided room/ space. The three sides closed and one open direct attention/ association to the space immediately in front of the opening. The heavy tile rail becomes a partial wall increasing the sense of enclosure and privacy. Privacy is increased by elevation of the porch above the street.
2. The open porch in drawings 25 & 29 is a covered outside space allowing attention to be directed 90 degrees. The open railing defines the limit of safety but does not confine association with the spaces beyond. Windows opening onto the porch allow association between the interior spaces, the porch space, and the spaces beyond. Privacy is maintained by elevation above public areas and distance from other private and public spaces.
3. The Window balcony, drawings 25,26 & 30, provides a minimal association with exterior space. It allows 180 degree direction of attention and when the windows are open it serves to extend a portion of the interior space to the outside and the built use surfaces of the balcony. When supported by a cantilevered floor, the balcony is more associative as an extention of something from inside to outside. When supported by corbled masonry, the balcony becomes a spacial element of the wall, the association being with the wall. Privacy is maintained by elevation and distance from nearby definitions.
4. Cantilevered balconies, drawings 24,27 & 31 are similar in design to open porches, drawing 29. Because they are cantilevered, the practical depth is limited to 6-10 feet. Since these balconies are built in space, spaces are defined above and below the floor. In the section shown, substantial cover is provided over the door below. Cantilevered balconies may be protected by a roof or left open. If uncovered, the balcony space becomes part of the building's exterior space and, therefore, more public in association. Putting a roof or partial roof over the balcony allows the balcony space to associate more closely with interior covered space. The balcony becomes more private.
5. Supported Balconies/Enclosures, drawings 26 & 32, allow extension beyond the lower walls much greater than that permitted by

cantilever. In addition, balcony supports define use spaces under the balcony.

Depending on support design and ground form, the lower covered space can become useful as circulation along a colonade with individual spaces formed between the columns. Note in drawing 26, openings in the wall are related to particular spaces between columns/supports. This strengthens the individuality of each bay. Exterior to the covered space, association with the column bays is less strong and activities occur more easily across several bays. Covered ground spaces may be either public or private depending on related uses and distances from associated activities.

comments

Relation to exterior spaces and activities can be facilitated by a number of balcony forms. Depending on individual house relationships to nearby public and private spaces, an appropriate form can be used to provide the degree of privacy/association desired.

Notice in drawings 24, 25 & 26, a variety of forms are used in close proximity producing a variety of individual associations with public spaces.

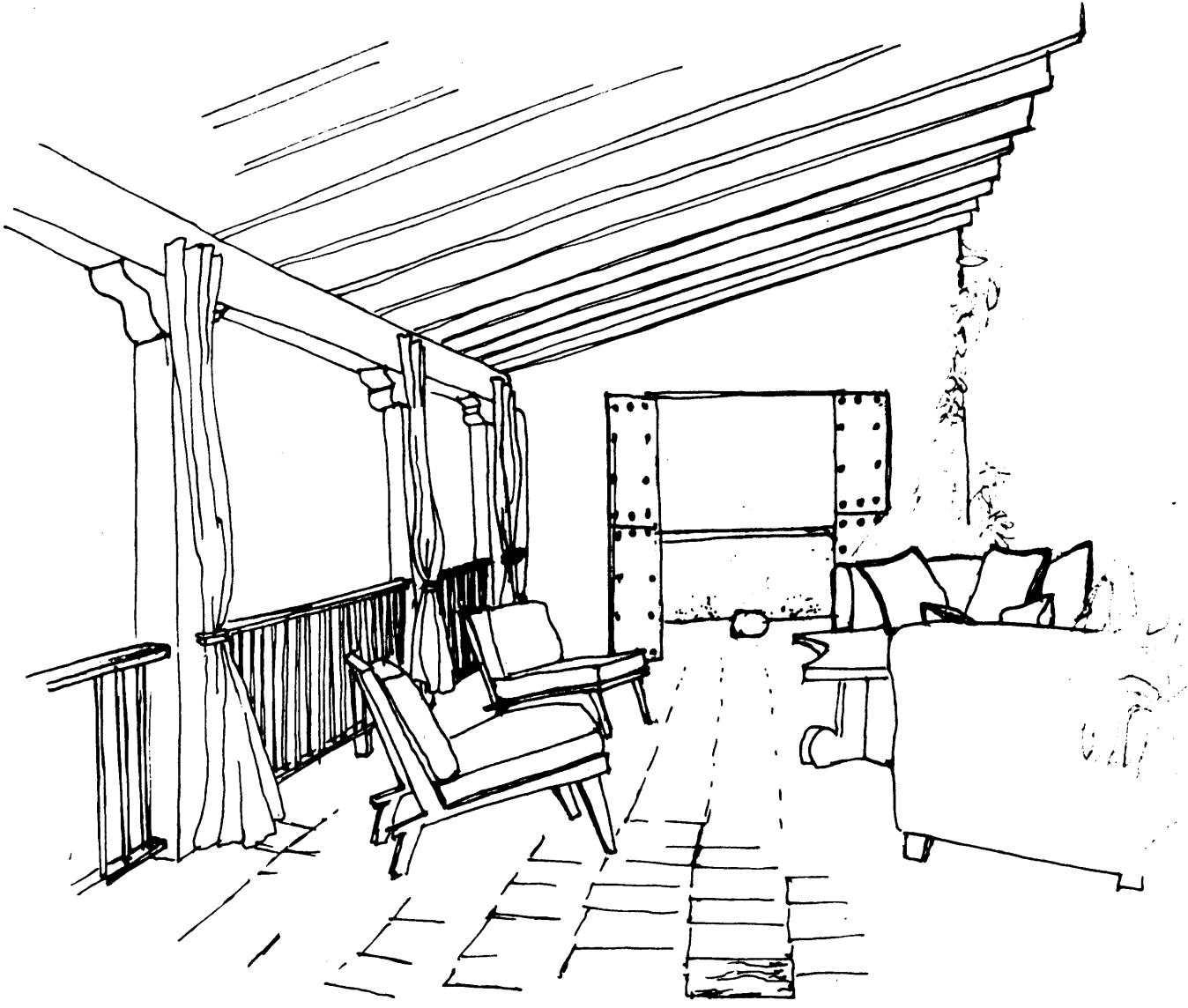

drawing 33

Guernavaca, Morelos
Second Story Loggia

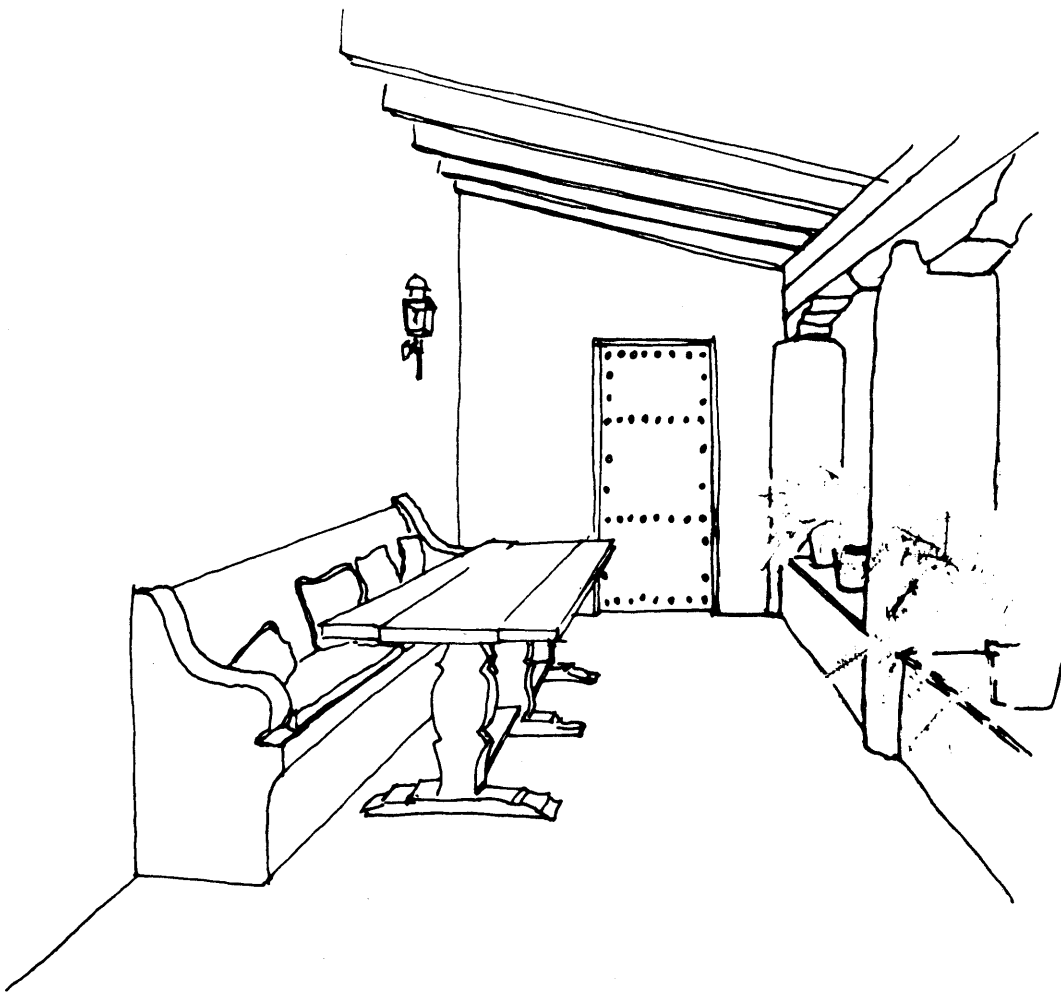

drawing 34

Guernavaca, Morelos
Dining Area

drawing 33 - 34

associative form

1. Direction of the verandas in drawings 33 & 34 is closely associated with moving along the line of columns. The columns define spaces and the association is to move from one space to another. Further defining this direction are the doors/openings at either end of the verandas.
2. Contrasting the two illustrations, the veranda in drawing 33 is wider, facilitating activities such as stopping and sitting. Note the large furniture. In the dining area in drawing 34, the veranda is just wide enough to permit a minimal dimensioned table while still allowing circulation.
3. Since the walls opposite the columns do not associate with/relate to the column bay, division of the veranda into distinct bays is reduced. This allows activities within the space to occur across several bays. Note the table extending across two bays.
4. With the open space on one side of the veranda, attention is directed at right angles to the direction of movement: from the wall through the columns. At the line of the columns a partial wall defines and partially encloses the veranda space in drawing 34. The wall forms a useable surface/space/zone along the line of the columns. The open railing in drawing 33 defines the extent of movement and allows greater association with the spaces beyond.
5. In both examples, the large beam at the top of the columns partially encloses the useable space, identifying the extent of the space.

Comments

Long, relatively narrow, verandas are associative/useable somewhat similar to the vault form: linear movement/transaxial uses & associations. The open side of the veranda can be associative as partially enclosing depending on design of railings, columns, and roof beams.

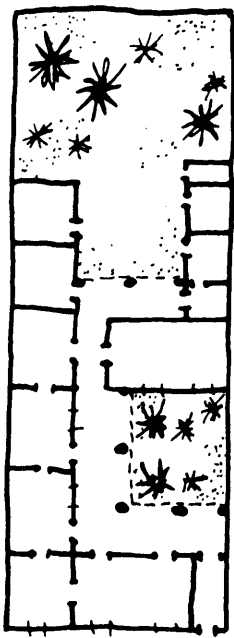
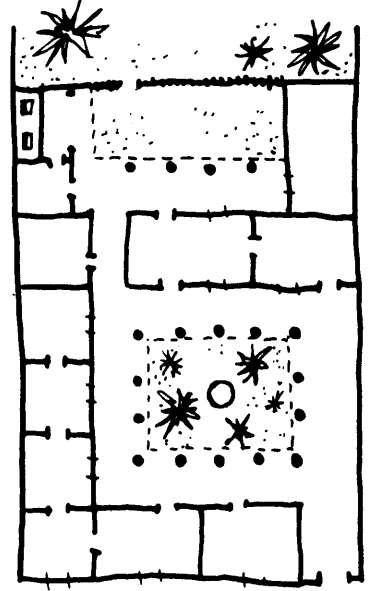
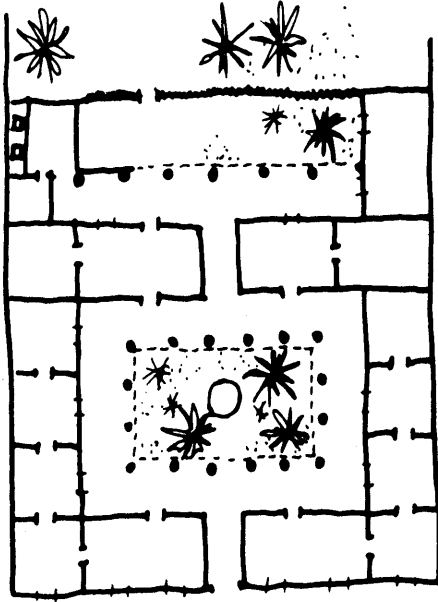
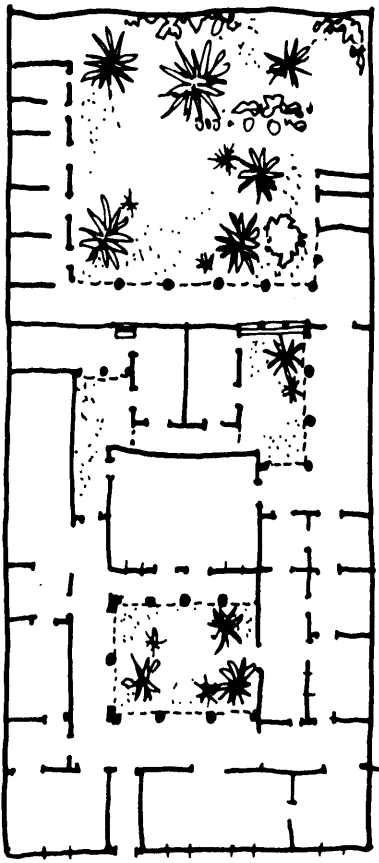

drawing 35

Verandas, Venezuela

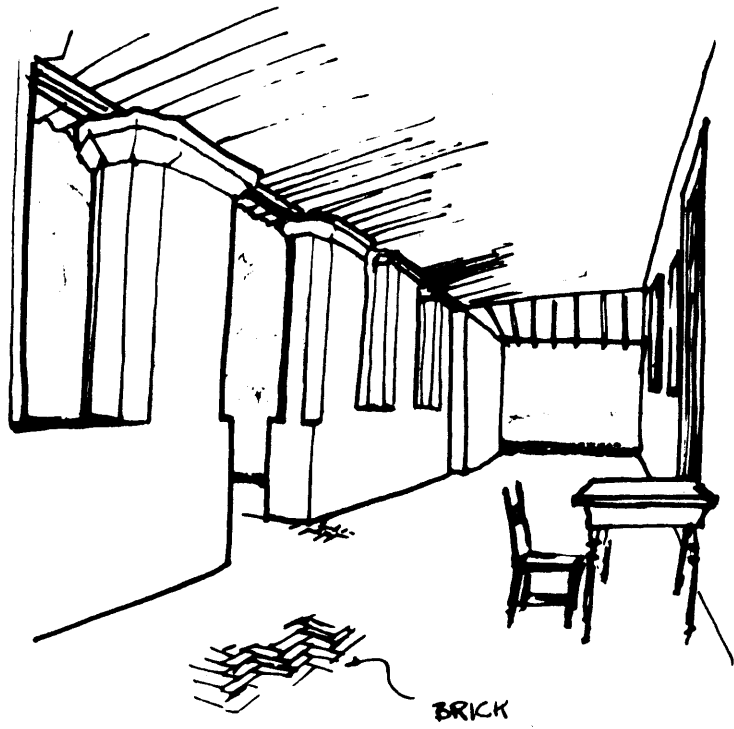

drawing 36

Veranda

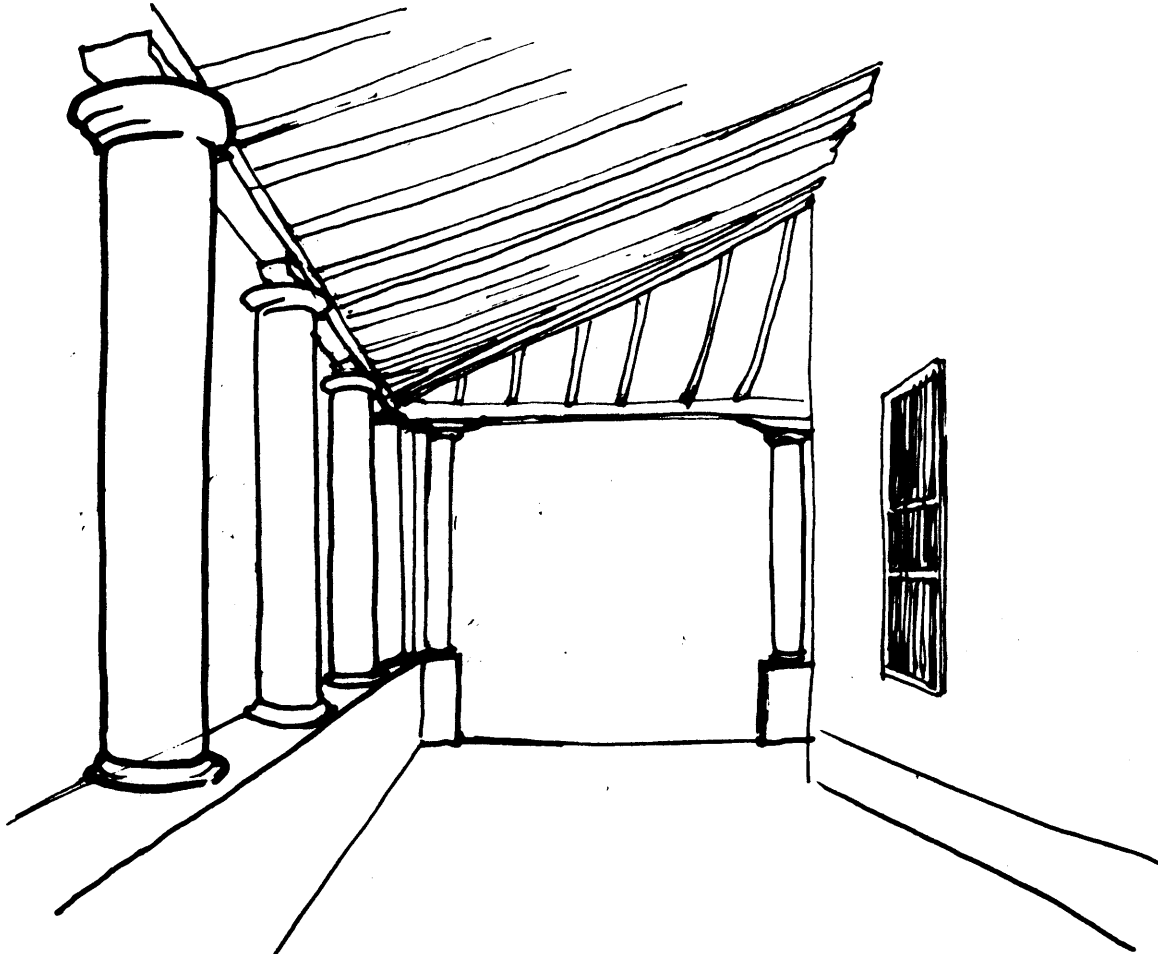

drawing 37

Veranda

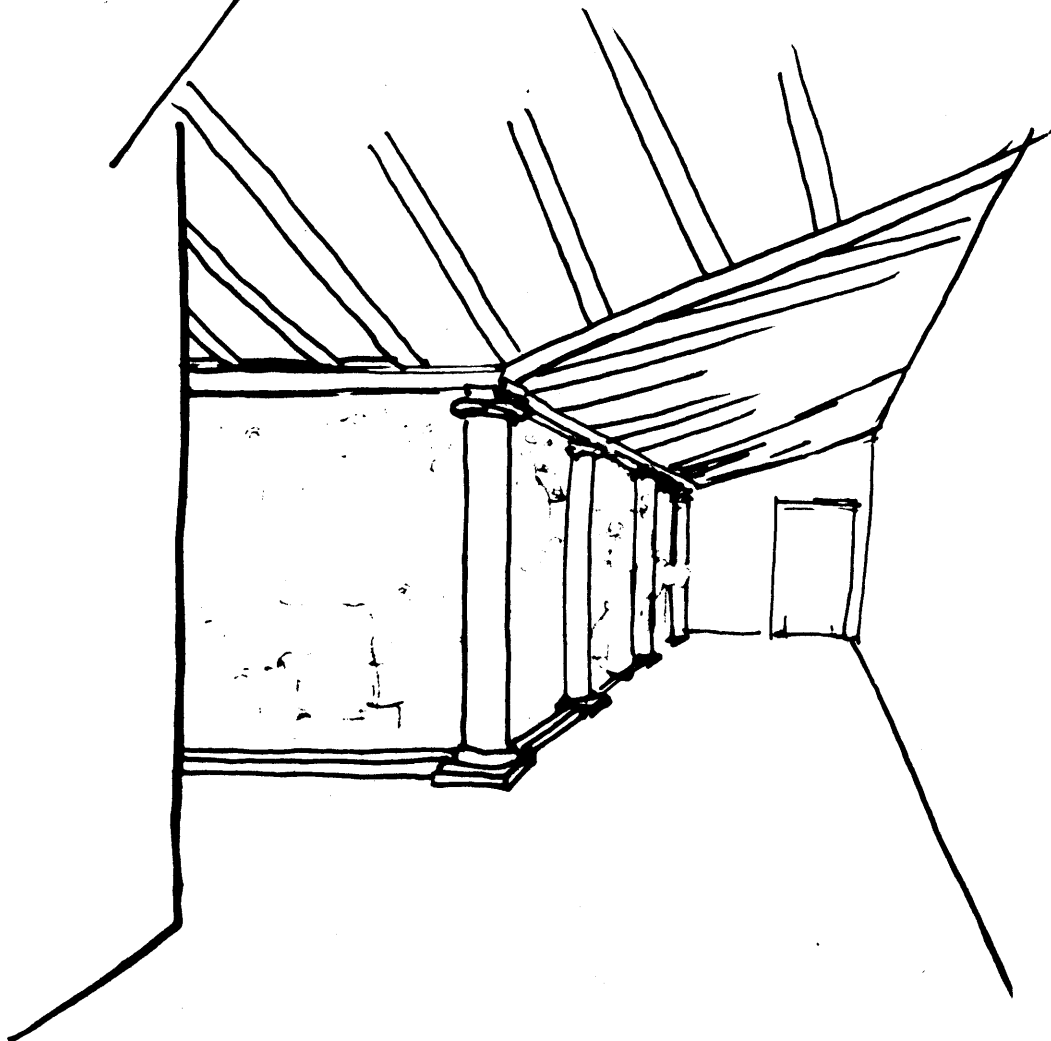

drawing 38

Veranda

46.



drawing 39

Veranda

REFERENCE ②
PAGE 141



drawing 40

Veranda

drawing 35 - 40

associative form

1. Verandas at ground level shown in drawings 35 to 40 are use spaces/zones either enclosing a court yard or forming an exterior edge of a building. When they are of sufficient width they can be utilized as exterior rooms/spaces with one side opening to more public spaces.
2. When columns rest on partial walls, the line of columns becomes partially enclosing/defining of the veranda and the open space. Walls of sufficient depth form use zones/spaces along the line of columns. Wall height can vary from 3 inches, as in drawing 38, to 4 feet, as in drawing 36, providing various degrees of enclosure. In drawing 36, roof supports become wall elements and enclosure is very strong. In this case, the veranda becomes a hallway/enclosed space with openings in one wall.
3. At ground level, walls need not be defined. Uses of the veranda spaces can extend from the covered spaces to the open spaces beyond the columns. In drawings 39 and 40, the ground form allows movement through the line of columns at one level, indicating common use of the ground spaces. Similarly, the shallow beams between the columns define the veranda space less distinctly than than deep beams. This allows greater association between the veranda and the open space beyond the columns.

Comments

When columns are used to define boundaries of a space, those boundaries can be minimized by designing ground form which encourages movement across/through the boundary. They can be maximized by building a use zone/space along the line of the columns, discouraging movement through the columns. How strongly this boundary is defined determines the relative degree of privacy provided on either side of the boundary.

drawing 41

Guernavaca, Morelos

Open Room

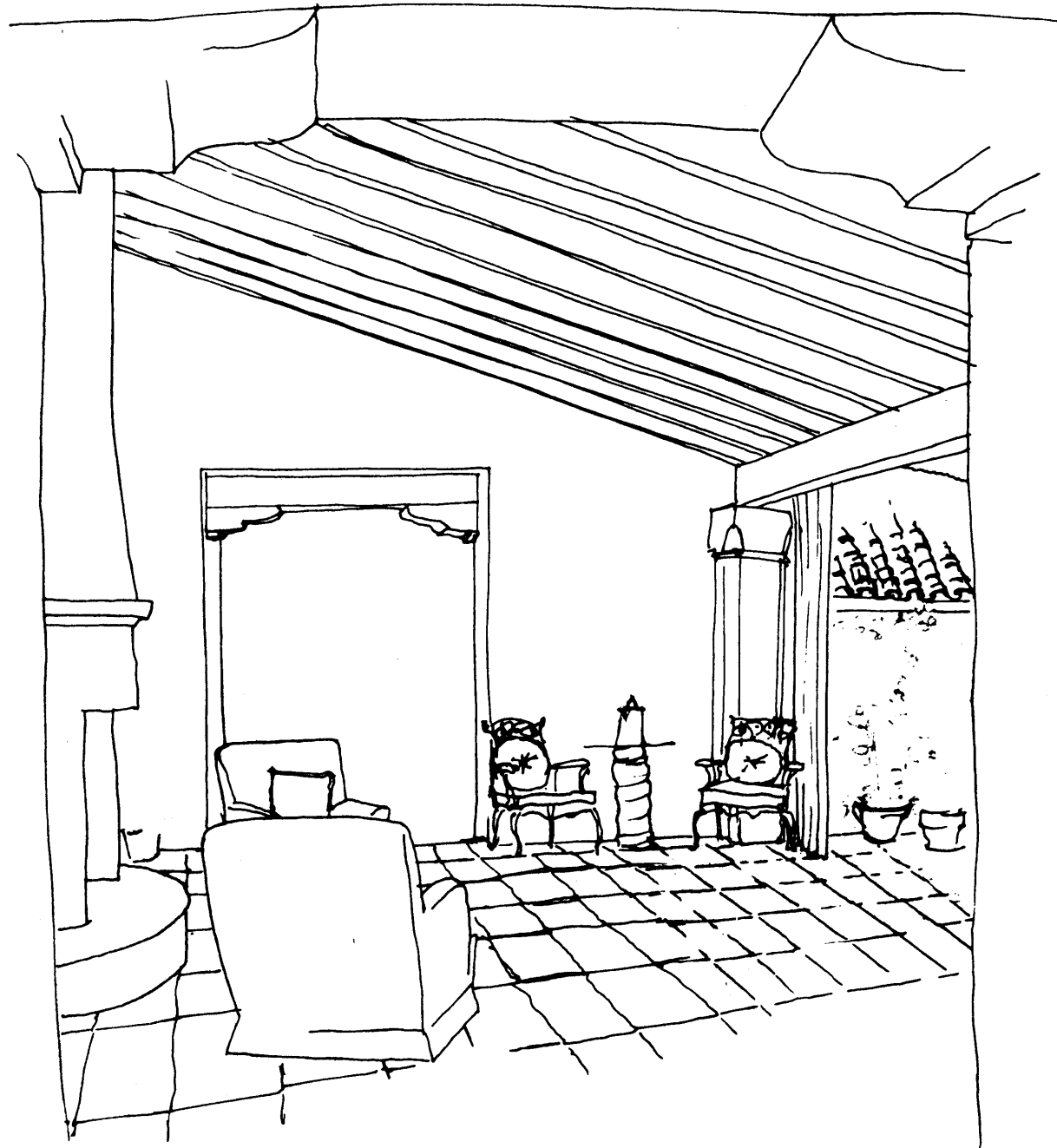

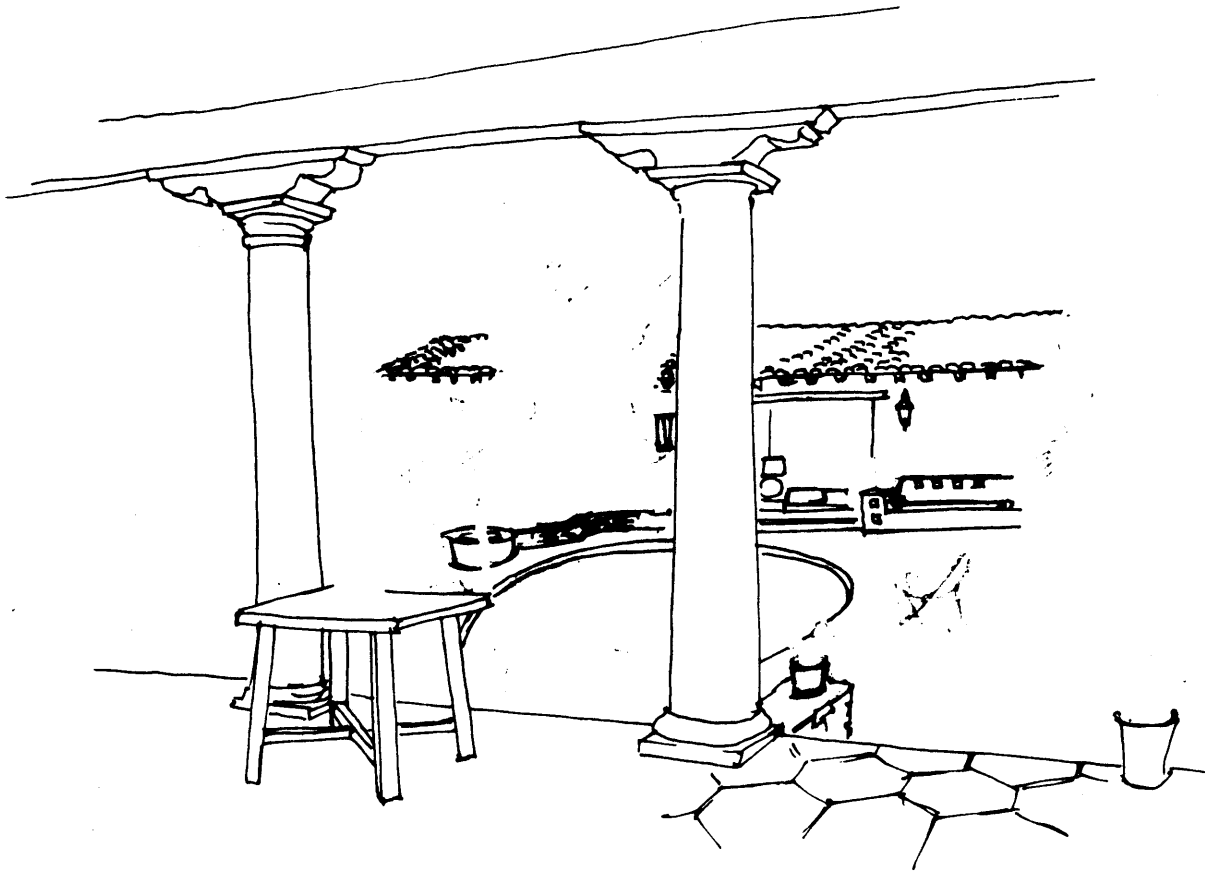

drawing 42

Guernavaca, Morelos, Open Room

drawing 43

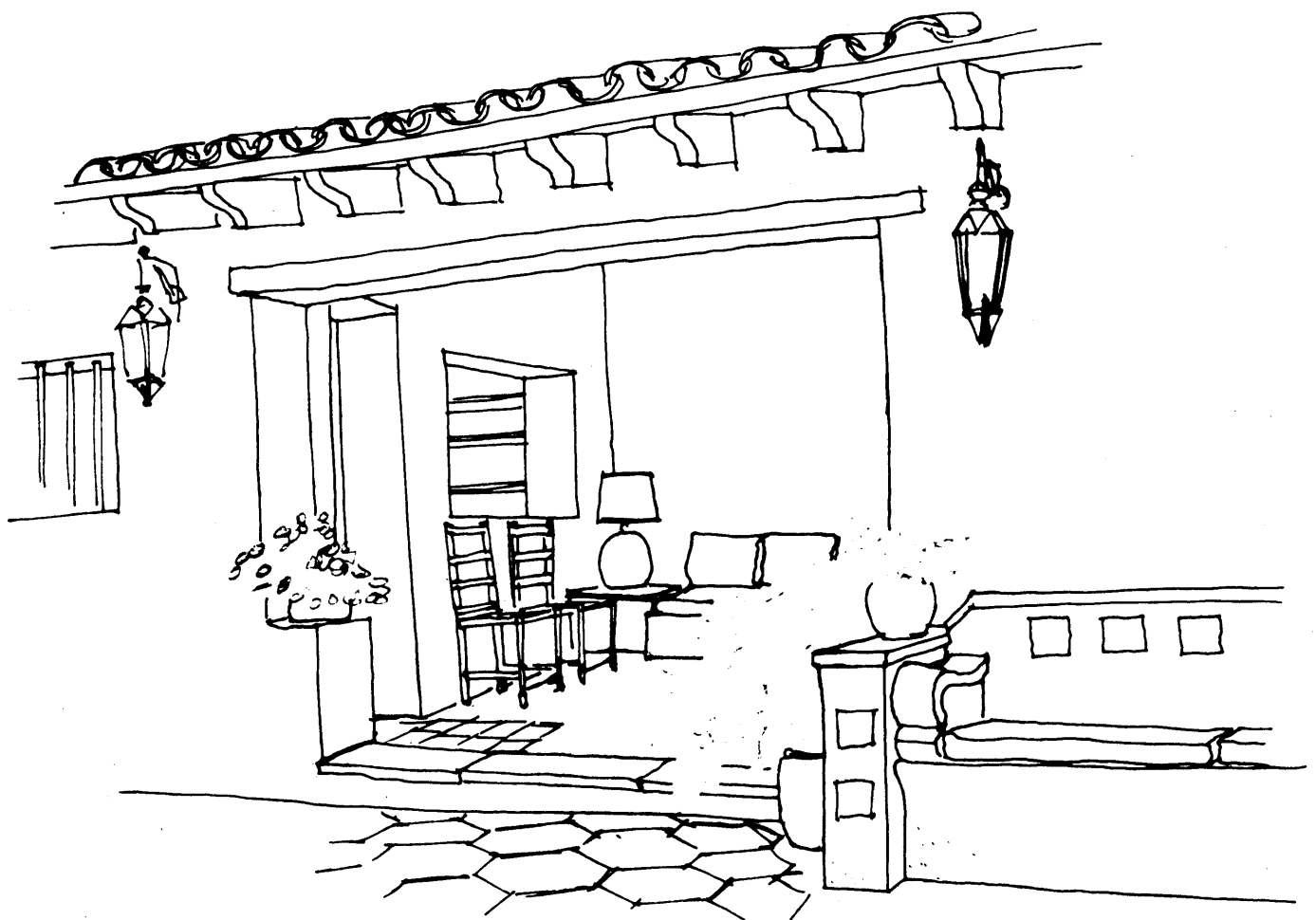

drawing 44

Guernavaca, Morelos

Open Room



drawing 41 - 44

associative form

1. The space in drawing 41 is essentially one bay of a veranda.
As such, with no additional bay to move to, the space loses the sense/association with movement along the line of columns. Instead, association/attention is drawn strongly out the opening.
2. The deep beam and columns on either side of the opening partially enclose the interior space in drawing 41. note that curtains can be drawn across the opening fully enclosing the space and making it much more private.
3. The open room in drawing 43 is more enclosed and separated from exterior spaces because of the change in ground level and design of the wall as a use space/zone. With a clear division of spaces, the interior space becomes more private, the association being separate space, separate use.
4. The open room in drawing 44 is similar to the previously discussed veranda designs. In this space, however, the depth of the space from the columns is so great that one large space is formed and the columns form an open screen on one side. The ground changing level beyond the columns increases the separation from exterior spaces and allows semiprivate uses of the space.

Comments

1. Given sufficient depth, open rooms/verandas eventually lose the strong movement association along the columns. The columns become screens/partial walls to the defined spaces.
2. Ground form and use spaces/zones can be used to partially separate spaces even though the spaces are visually open to one another. Ground level changes imply different use/association between levels.

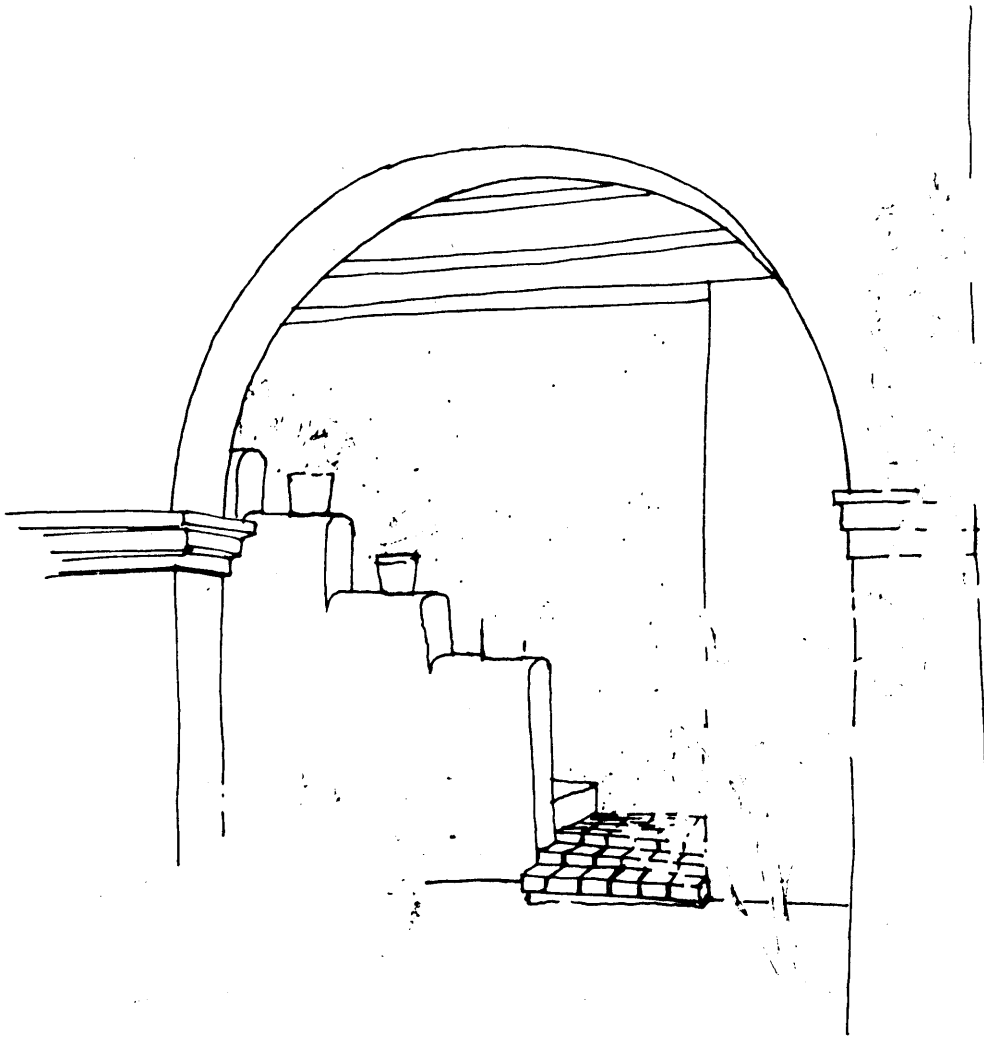

drawing 45

Tucson, Arizona

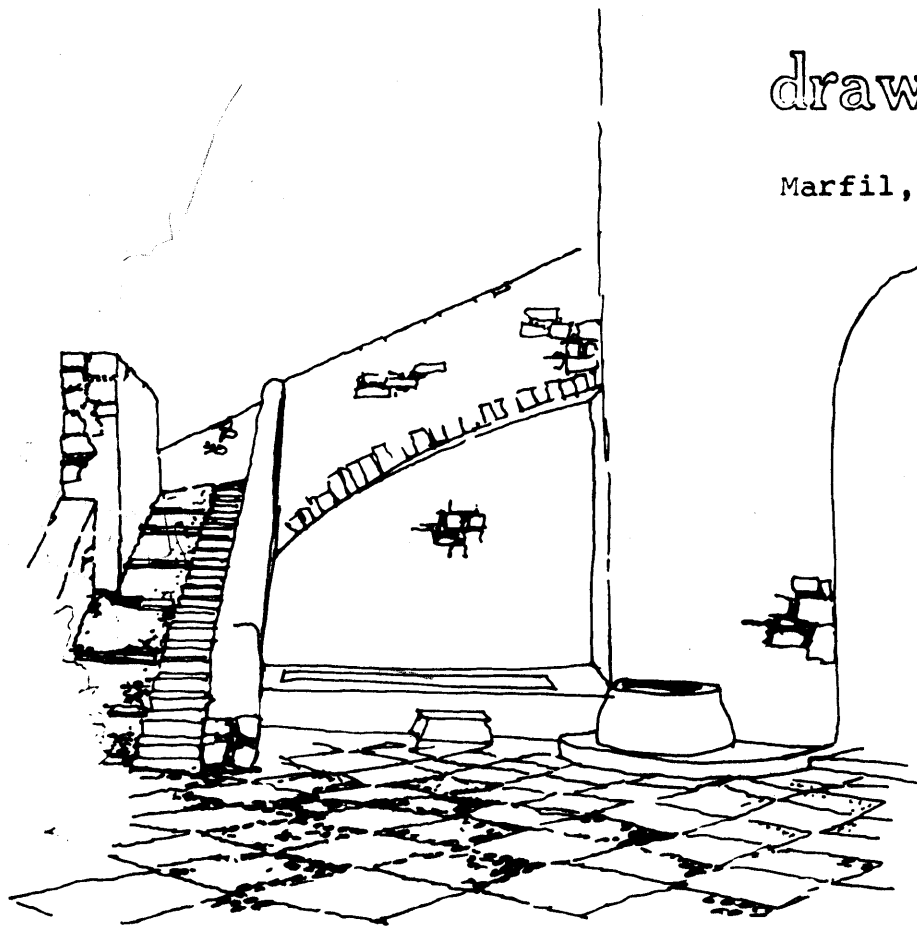

drawing 46

Marfil, Guanajuato

drawing 47

Guernavaca, Morelos
Stairs



drawing 45 - 47

associative form

1. Stepping up at half the frequency of the stair treads, the wall in drawing 45 forms small use surfaces/ledges along the stairs. These surfaces allow ample space for placement of objects or association by persons since the surface lengths are approximately the width of a person. These use surfaces also allow attention to be directed at right angles to the direction of travel on the stairs. In contrast, the continuous rising wall surface in drawing 46 directs attention up along the stairs.
2. The stair-ramp combination shown in drawing 46 allows multiple use of the stairs. Run-off breaks in the ramp every three or four treads allows movement in stages/additively verses continual rise on the steps.
3. The projection of stairs into the room space in drawing 47 allows a person descending to look down into the space he is entering. This allows the person to become somewhat familiar with the space and what might be happening in the space.

Comments

1. Surfaces associated with stairs can allow the stairs to be associative in stages or sections. Such associations can be additive and at reduced frequency to the stair treads. The built definitions in the vicinity of the stairs may allow persons to associate with spaces other than the stair space alone.
2. Elevated by stairs, persons may be given an opportunity to survey or preview where they are going from above and somewhat privately.

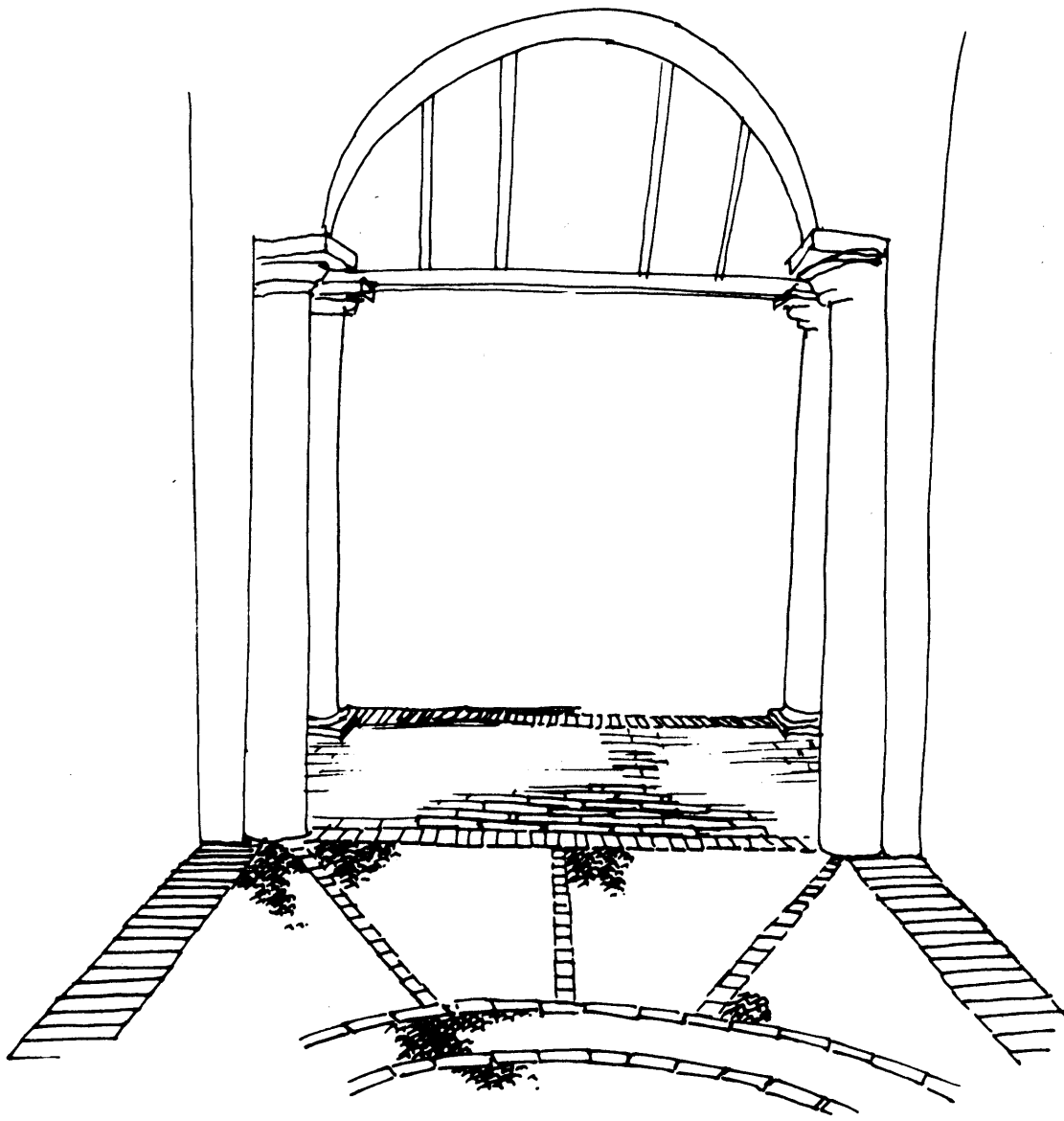

drawing 48

Entrance Area,
Veranda

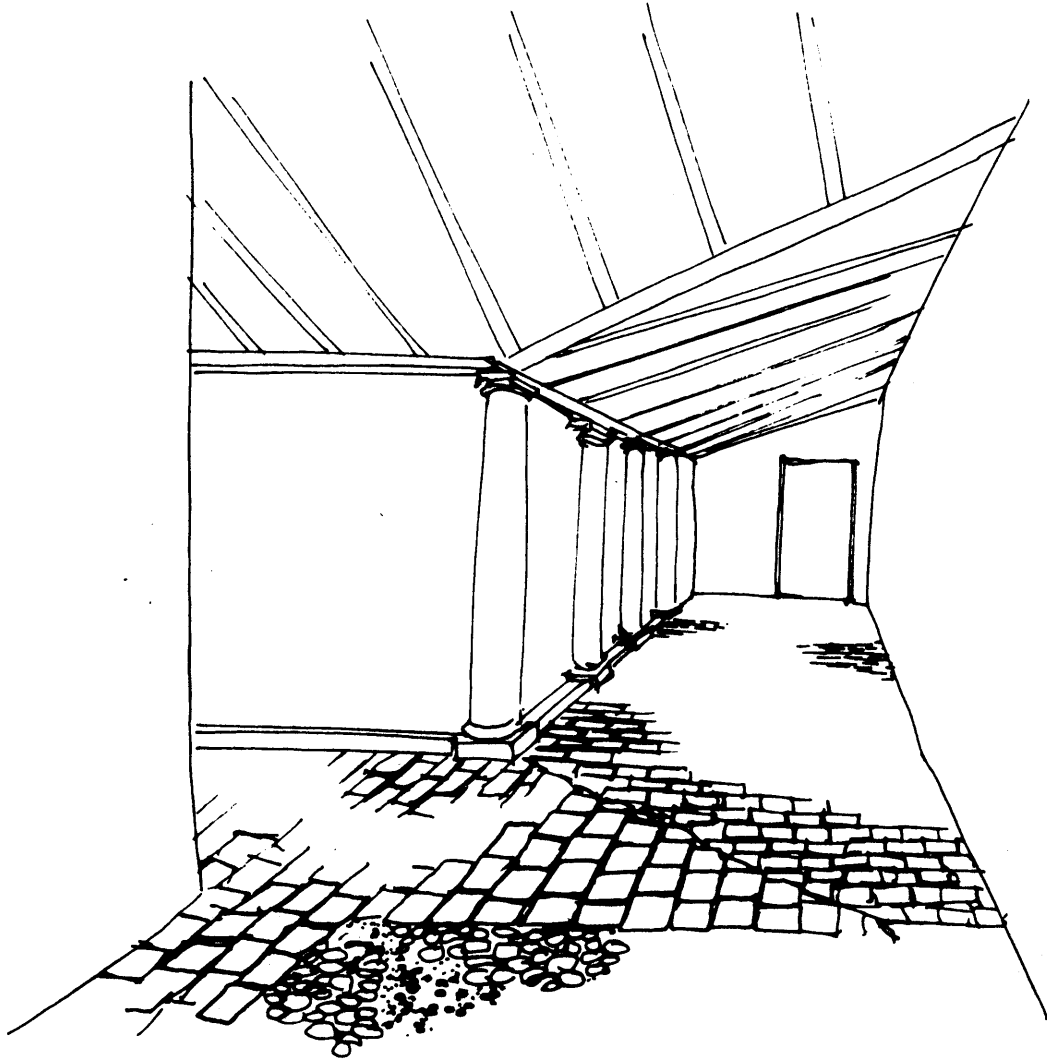

drawing 49

Veranda

drawing 48 - 49

associative form

1. When covered with certain patterns of bricks, walking surfaces/floors are given an associative direction. Similar to the board patterns discussed earlier, it is associative to move/step across the short dimension as course after course is encountered, stopping at any time before the next course is crossed. To right angles, association is to direct attention along the long sides of the bricks with no continuous break in the pattern to indicate stop. In drawings 48 & 49, the ground surfaces of verandas are covered with brick laid, in one case, transverse to the direction of the columns, and in the other along the direction of the columns. In drawing 48, the association with the brick is to move along the line of columns and along the brick without stop since the brick pattern is not stopped at any point. In drawing 49 the brick coursing builds additively along the line of columns permitting stops at any point directing attention into the court or to the wall.
2. Decorative patterns do little to identify movement directions but indicate special places for use/decision.

comments

Paving patterns can be used to reinforce the association with the built spaces. Breaks in patterns identify special places associated with different uses.

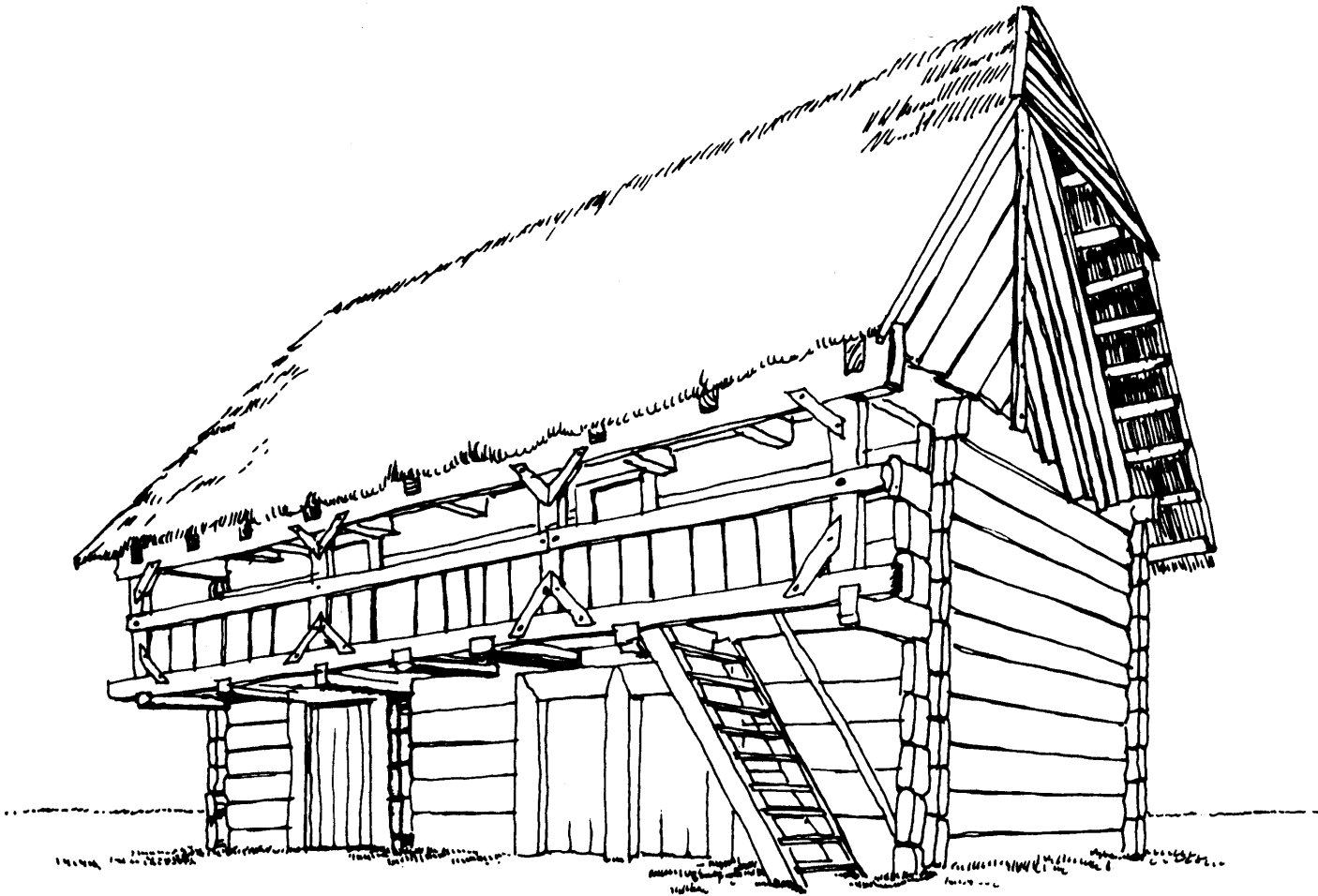

drawing 50

Log Construction

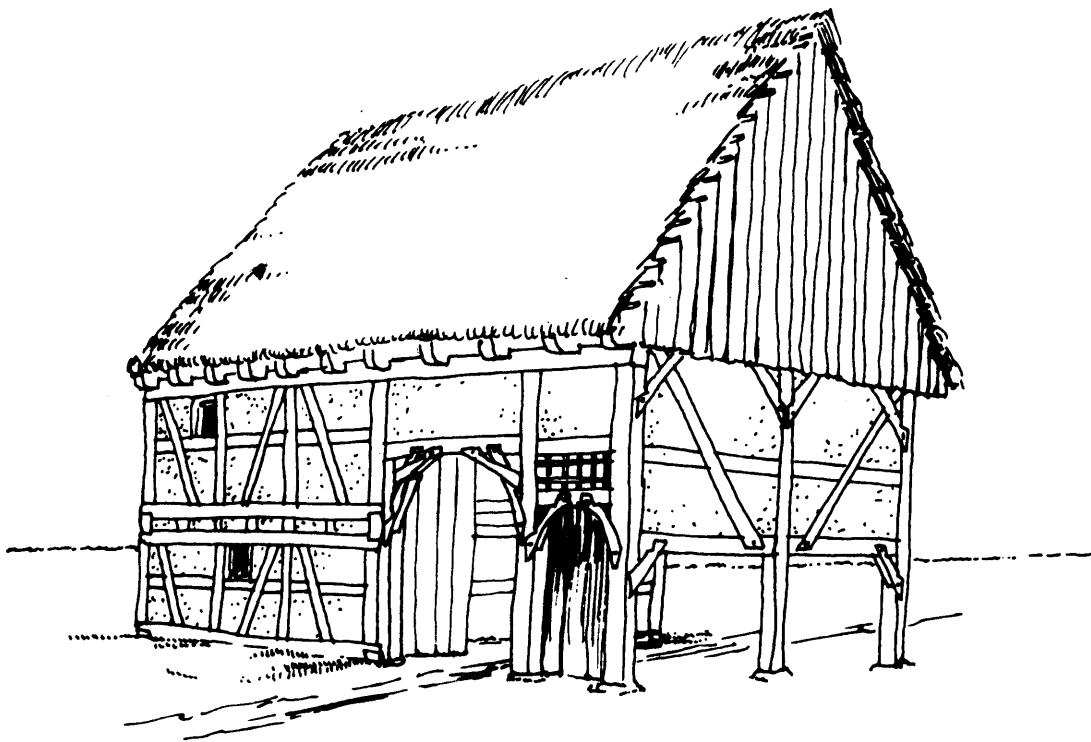

drawing 51

Braced Frame Construction

drawing 50

associative form

1. Walls built up with logs form continuous surfaces made from directional elements. In certain places, individual logs may be longer than others and extend into space to become load carrying beams, open frameworks, partial walls. Notice the balcony in drawing 50 is a framework of posts and beams with a board screen built between the railing and floor. Such frameworks define spaces while allowing association with the spaces beyond.
2. Interior log walls often interlock with exterior walls allowing position of these walls to be seen/associative from the outside. Similarly, floor beams interlock with the walls indicating levels of floors.
3. Note in drawing 50, space is created in the balcony floor for the stairs. In this case, space at the foot of the stairs is associated with the space of the balcony above. At the same time, the two entrances under the stairs are given more protection/privacy.

comments

Composed of lineal elements, log construction allows easy extension into an open framework/screen construction. Although not illustrated, the dimension of logs allows creation of use surfaces/zones within the depth of the walls and width of the beams.

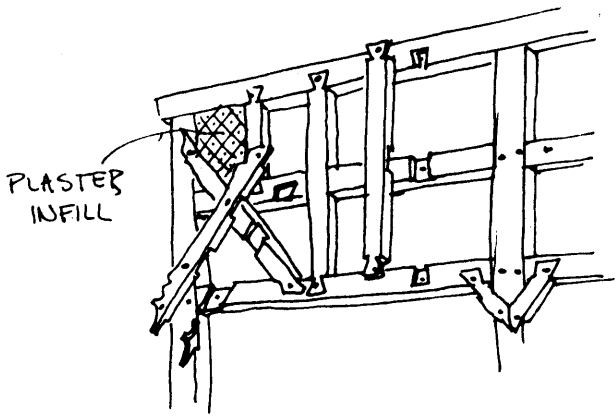
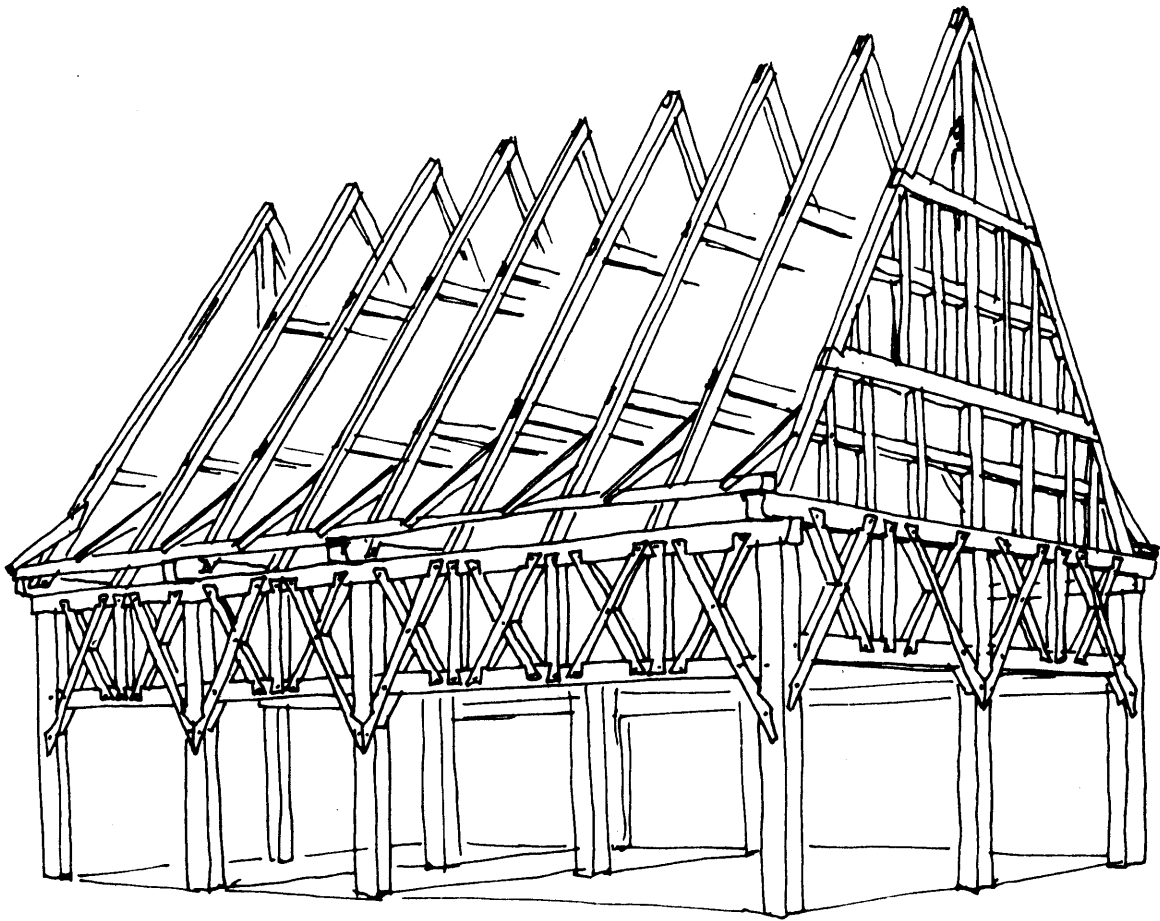

drawing 52

Braced Frame Construction Details

drawing 51 - 52

associative form

1. Drawings 51 & 52 illustrate a construction technique using posts and beams with rigid cross bracing timbers making braced frames. Although the framework members may be open in the interior of the building, the surface frames are made continuous surfaced by infilling with plaster. Taken as a unit, each frame can be seen to be added on top of or besides previous frames. Each frame, in general, has a habitable/associative dimension of 5-10 feet. Larger spaces are obtained by addition of more frames sometimes forming trusses.
2. Drawing 51 indicates that specific portions of the framework may or may not be enclosed. When not enclosed, the space is defined by columns, beams, and surrounding surfaces. The degree of enclosure determines the association with surrounding spaces.
3. Note the foundation requirements for the structure shown in drawing 51. When braced frames rest directly on the ground, continuous surface foundations are required. When posts carry the frames in the air, only footings for the posts are required.

Comments

The system of building with braced frames allows continuous surface definition and easy transition to open framework definition since the framework members are always present and visible. Even when frames are infilled with plaster there is a strong association with the structure as an open framework with screens.

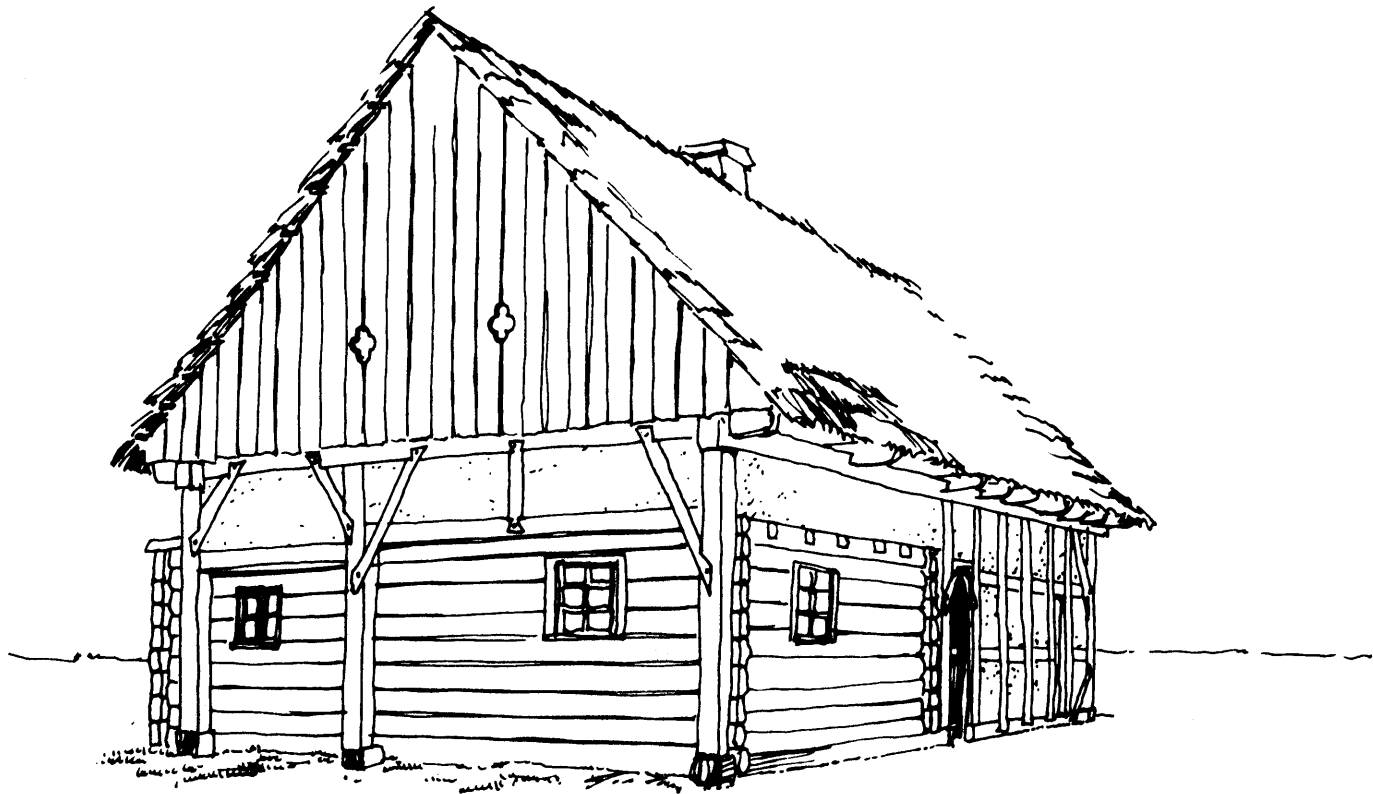

drawing 53

Log and Braced Frame
Construction

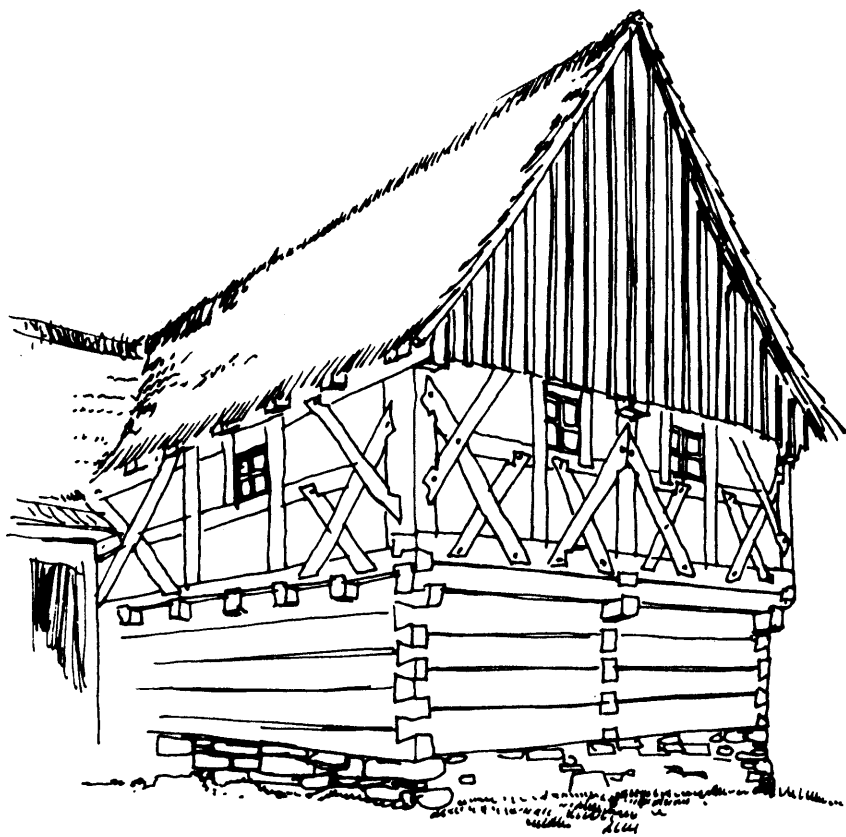
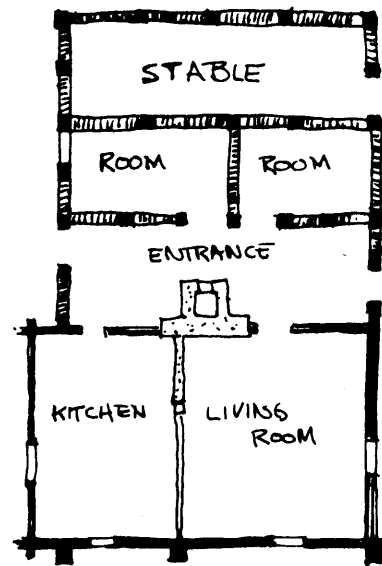

drawing 54

Log and Braced Frame
Construction

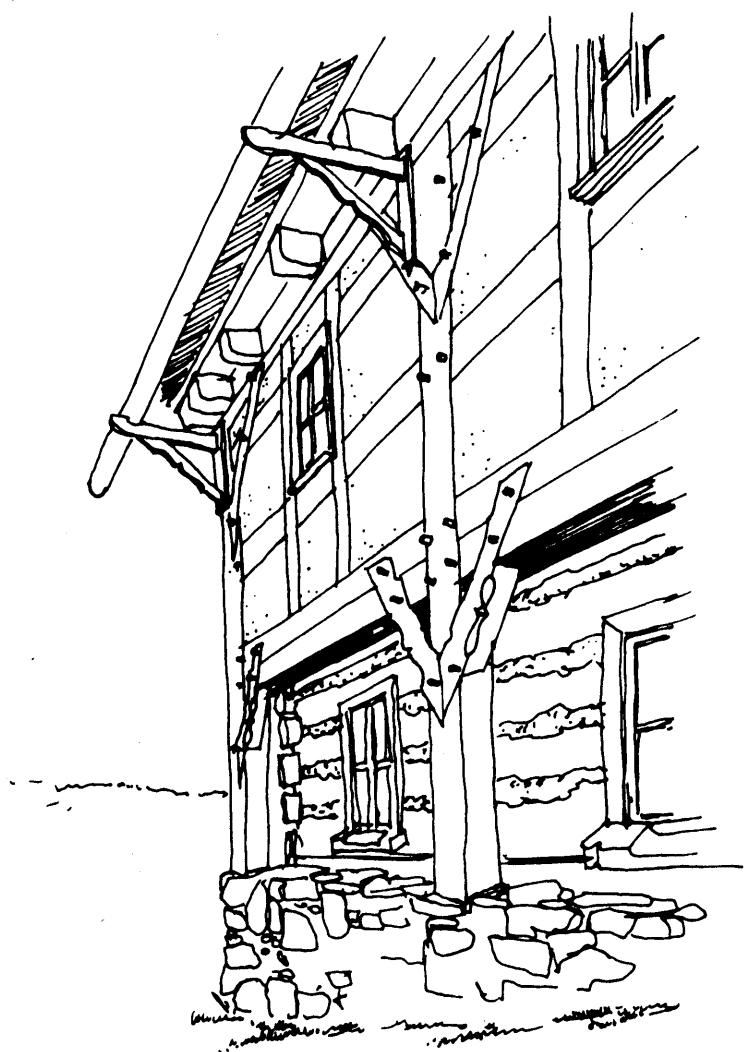

drawing 55

Log and Braced Frame
Construction

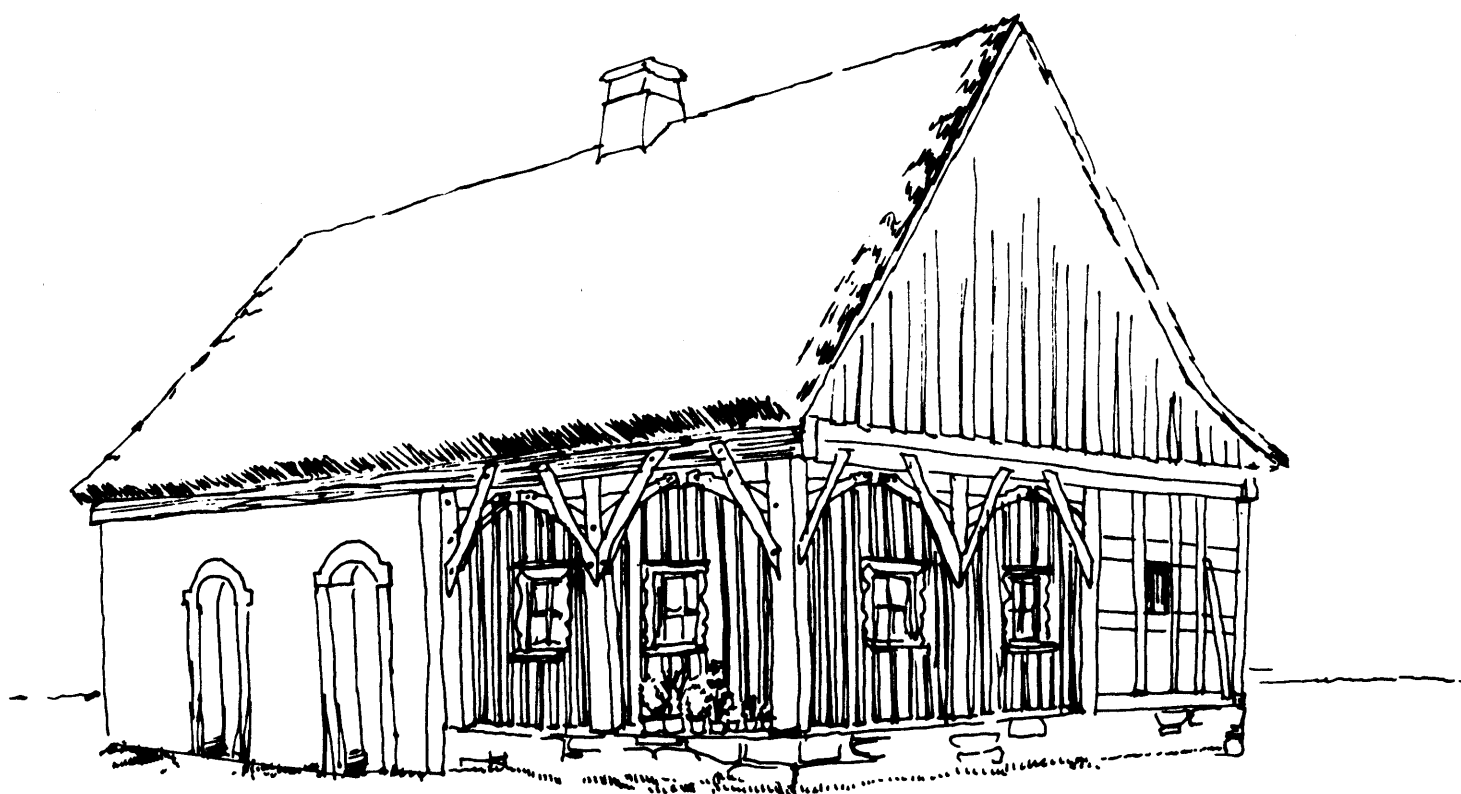

drawing 56

Post & Beam, Braced Frame,
Masonry Construction

drawing 53-56

associative form

1. Drawings 53 to 56 indicate combinations of building techniques, perhaps representing additions made over a period of time. In drawing 54, the log construction of the lower walls form continuous support for the braced framework above. Note, an interior log wall is indicated by the ends of the interlocking logs. Because log walls and braced frame walls each have identical surfaces inside and outside, some character of the interior is realized/associative from the outside.
2. In drawings 53 & 55, the braced frame over the log walls is actually supported by posts standing free of the walls. Used in a minimal way, the posts partially define a spacial zone along the log walls. In one case, a useable/associative ledge is built to support the posts. It is important to realize that these spacial zones relate to activities exterior of the house, e.g. placing objects, sitting, etc.
3. Comparison of upper and lower story windows in drawing 55 illustrates basically different openings. In the braced frame, framework members define/form a space in the frame which is then glazed. Such an opening has a direct association with framework elements nearby since it is defined within the larger framework. In the log wall, the window is an opening in a continuous surfaced wall. Its position is less determined by the elements of the wall and therefore, has little association with the wall and the nearby surfaces. It makes minimal disturbance of the continuous surface wall.
4. The building in drawing 56 illustrates that continuous surface masonry is equally compatible with post and beam and braced frame building techniques. Generally, the switch from one system to another occurs at shared members. In this building, little spacial definition is realized from the junction of systems.

comments

1. Complimentary use of two or more building systems/techniques is possible and allows association with related spaces in ways not possible using just one system. Junctions of different systems

need not be planar but can be space defining to provide additional use zones/associations/definitions.

2. Openings built/defined by elements which relate to definitions nearby allow association with a zone greater than the window itself. Openings in uniform-continuous walls/surfaces, have little association with surrounding definitions. Instead, the association with the surface is little changed by the opening.



drawing 57

Log and Board
Construction

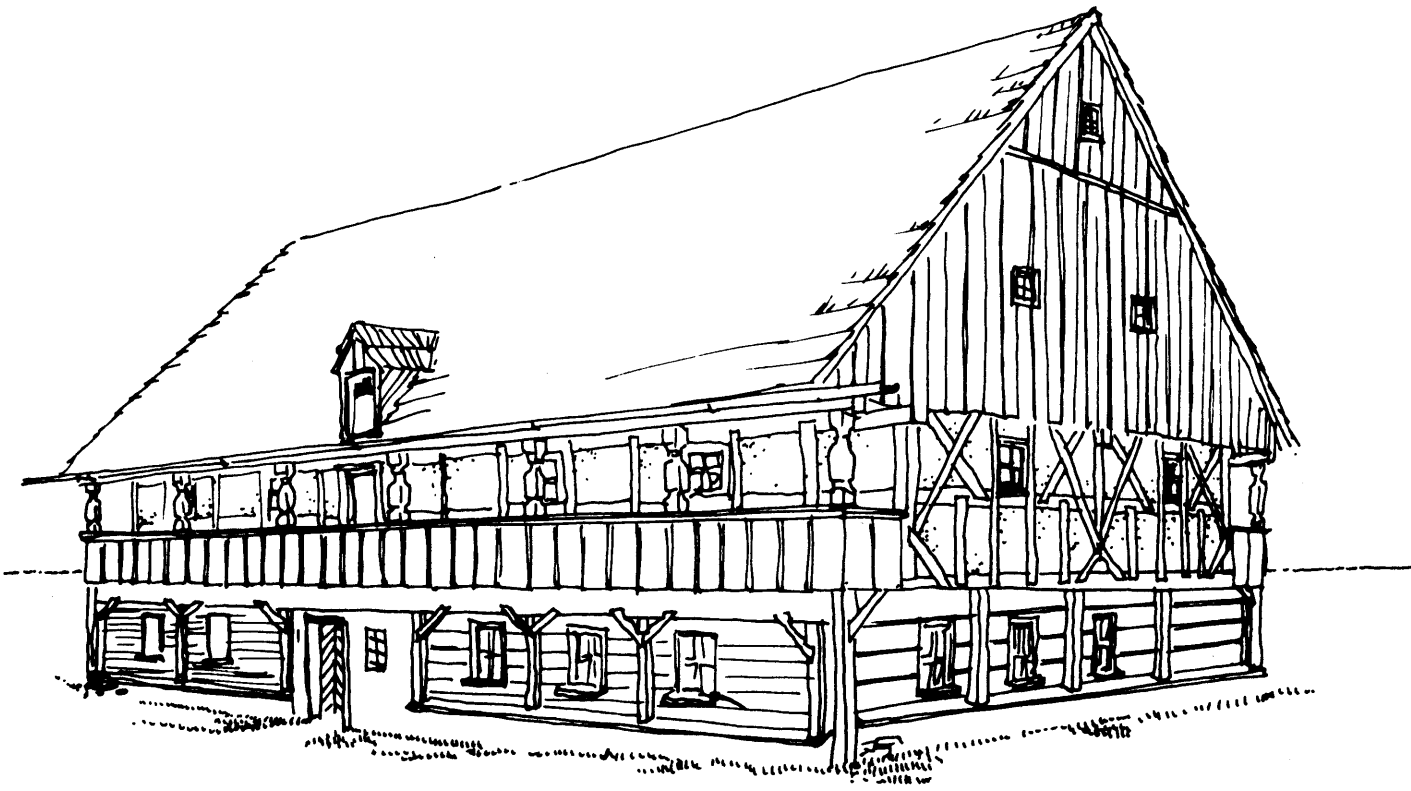

drawing 58

Log and Braced Frame
Construction

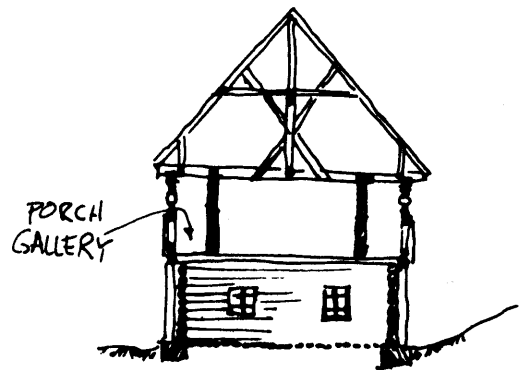

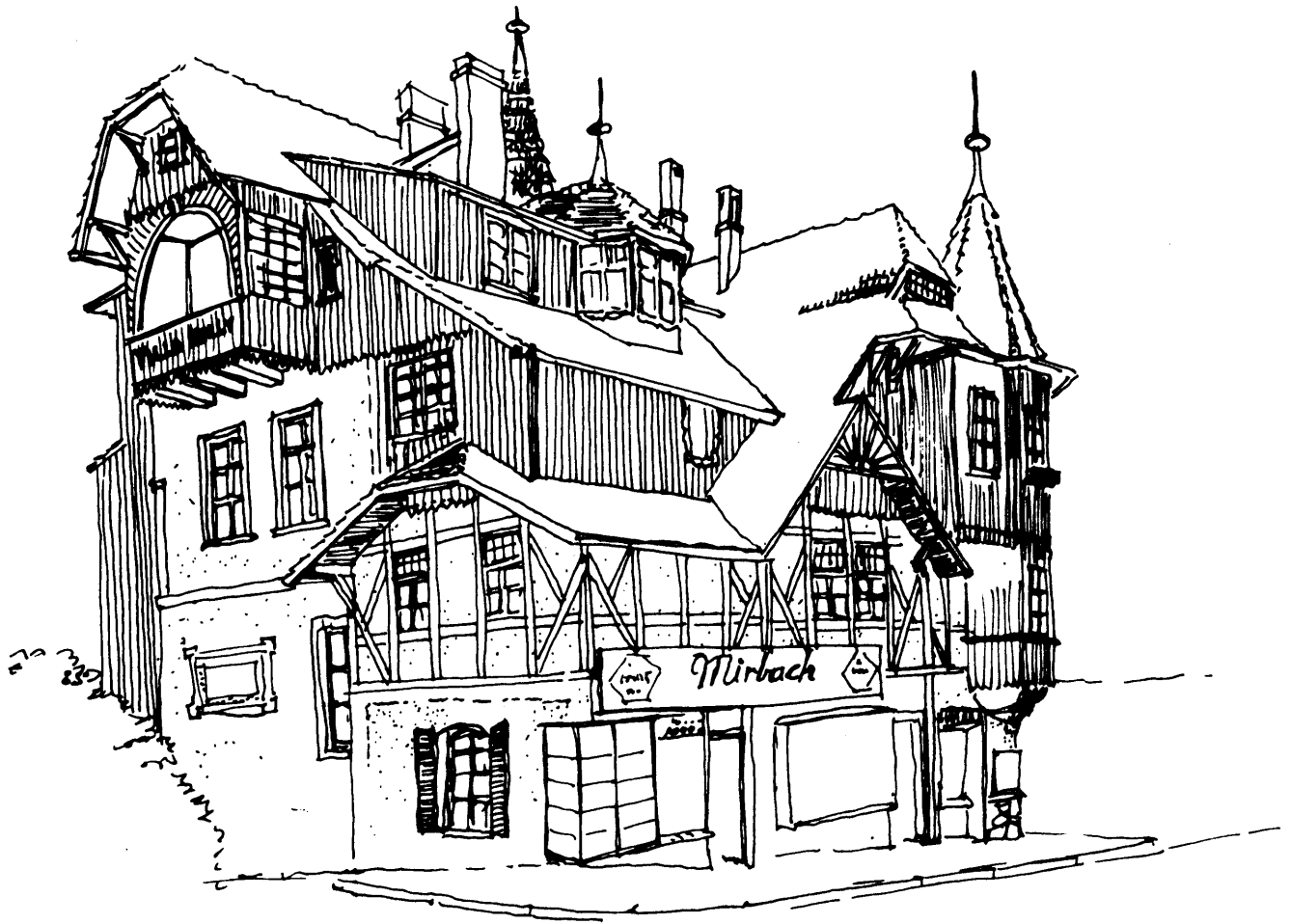

drawing 59

Masonry, Braced Frame, and
Board Construction

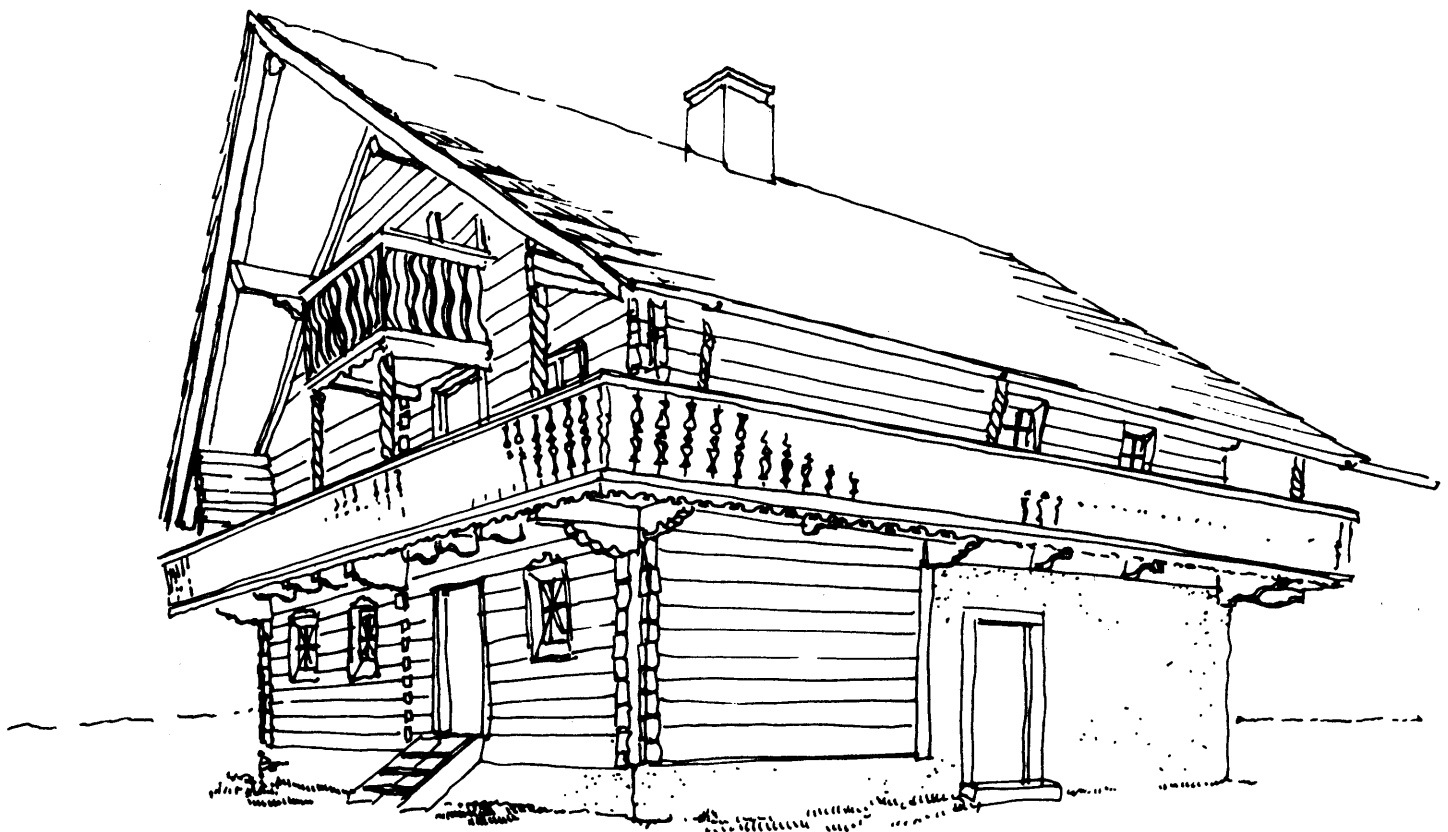

drawing 60

Masonry and Log
Construction

drawing 57 - 60

associative form

1. Because of the harsh weather suffered by the buildings in drawings 57 to 60, large roof overhangs, and protected porches and balconies are built. Overhangs for windows, porches, and balconies are associative as protection in the severe weather, even protecting the walls.
2. In drawing 59 several distinct building systems are utilized to create/define the building. At lower levels, simple masonry forms define the ground floors and the associated commercial activities. Braced frames define the next level also simple in form, accommodating either commercial or residential activities. With height, the building system changes to light weight beams and boards. This last system consisting of smaller structural elements responds to smaller sized residential uses intended on the upper floors.
3. The railings illustrated in drawings 57, 58 & 60 present a variety of closures for the balconies. They range from full closure/continuous surface to spaced boards with cut openings. The spaced boards allow greater association with the exterior while still providing weather protection.

comments

Since most building systems are limited in the range of sizes they are able to define, it is reasonable to utilize several systems in providing a range of definitions. In addition, distribution of activities/privacies may determine where particular building systems will be more predominant in the final structure.

drawing 61

Stairs

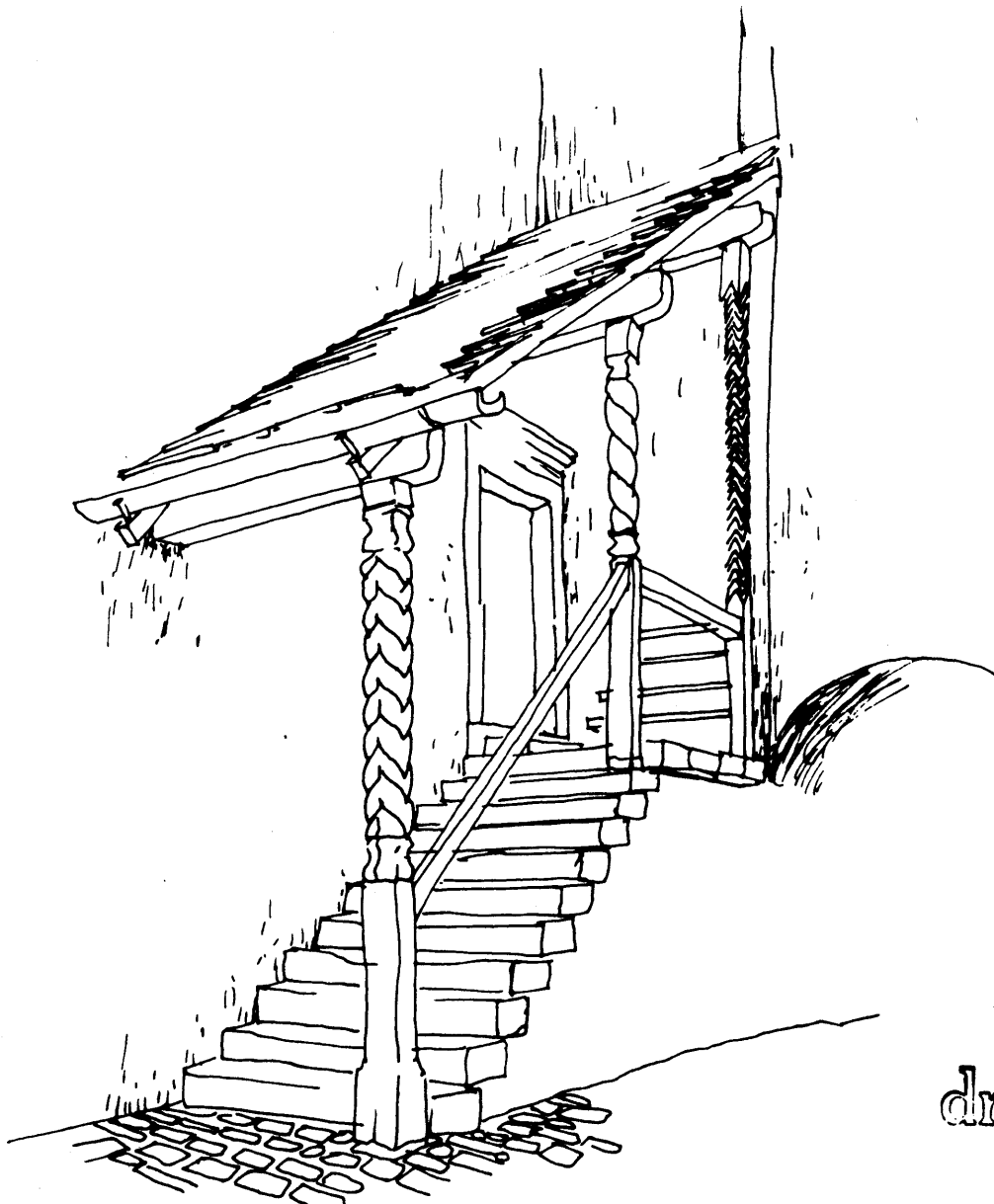
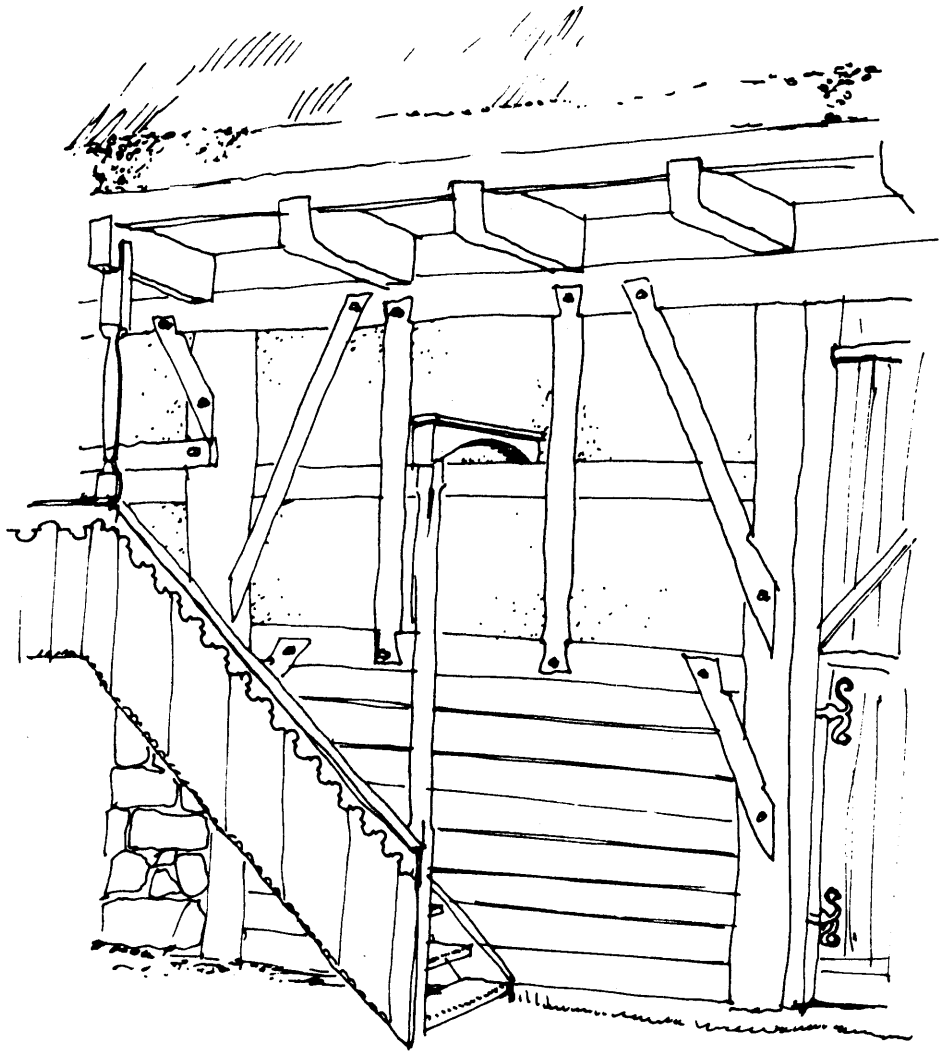

drawing 62

Stairs

drawing 61 - 62

associative form

1. Although moving up in larger spaces, the stairs in drawings 61 & 62 maintain a human associative dimension by providing cover nearby overhead. Railings and roofs partially define spaces particular to the stairs allowing some privacy to be maintained while moving in the larger space.

comments

Whenever there are smaller scale activities in a larger space, opportunity can be taken to make the associated definitions semi-private from the larger space, thus, partially defining the larger space by virtue of its associations with peripheral definitions and activities.

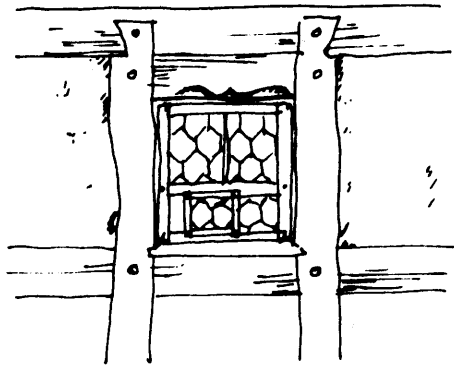

drawing 63

Windows

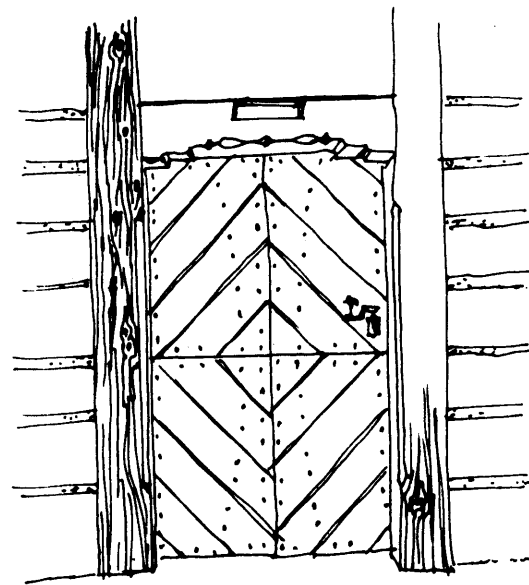
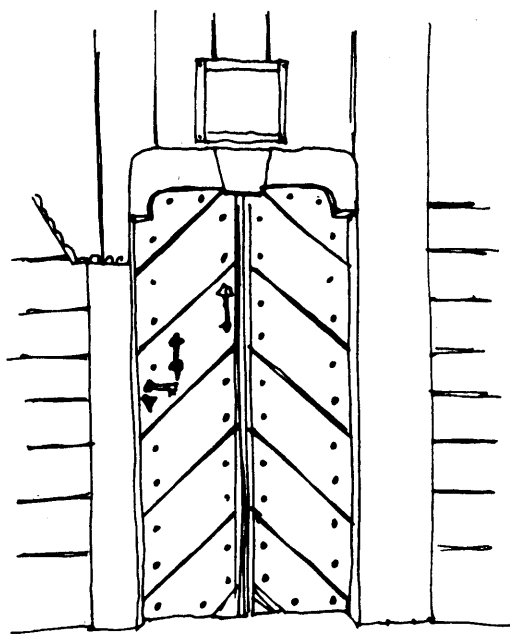

drawing 64

Doors

drawing 63-64

associative form

1. The windows in drawing 63 indicate the relative details of a built opening and an opening cut in a continuous surface.
The sliding shutters represent another method of closing the opening. The operation of the shutters defines a larger zone on the wall than windows considered earlier.
2. The doors represent openings in continuous surface log walls.
In this case the direction and surface of the wall is interrupted by a vertical post. Note the rounded edge on the post, associative with approaching/leaving the door from many directions.

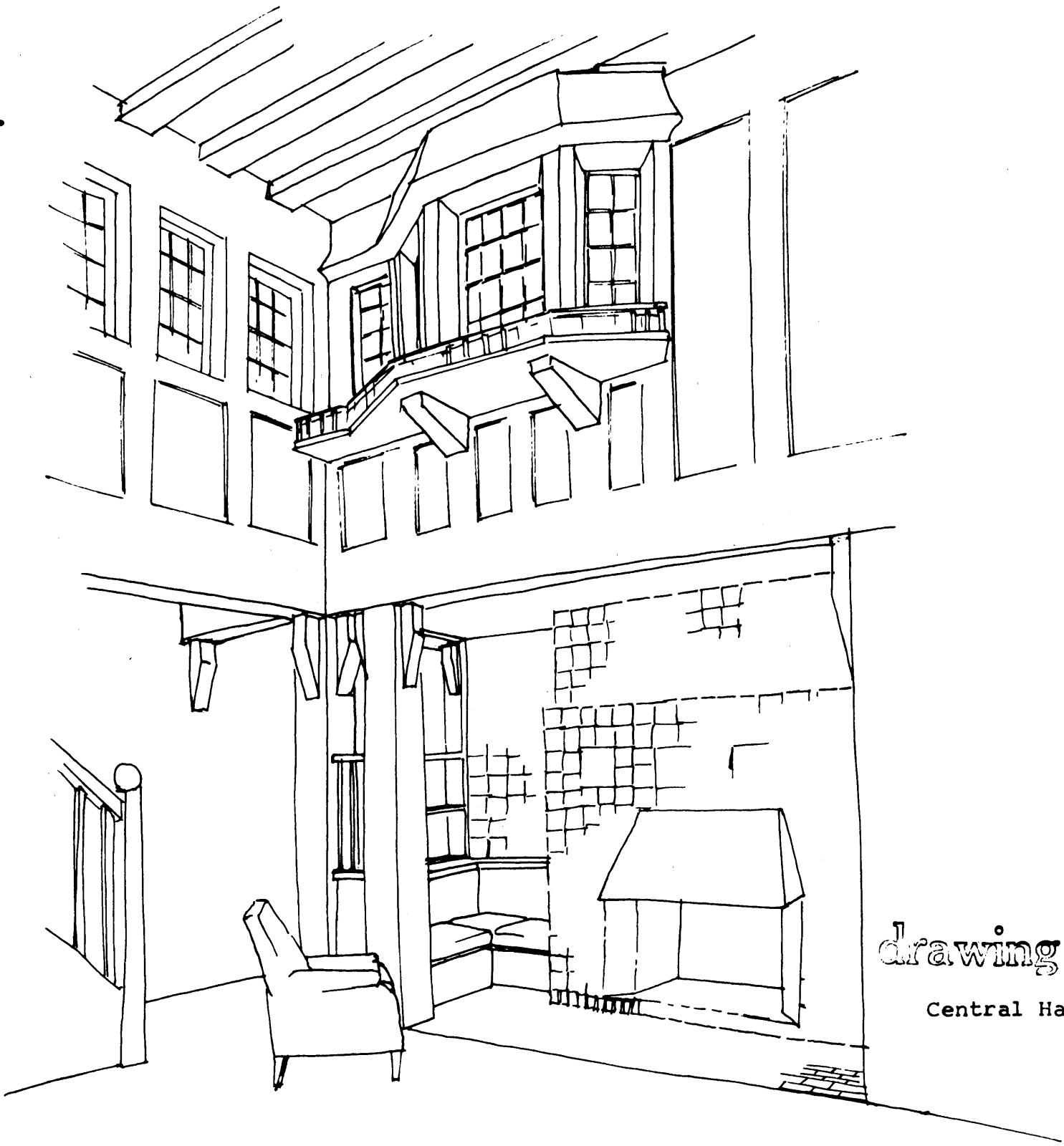

drawing 65

Central Hall

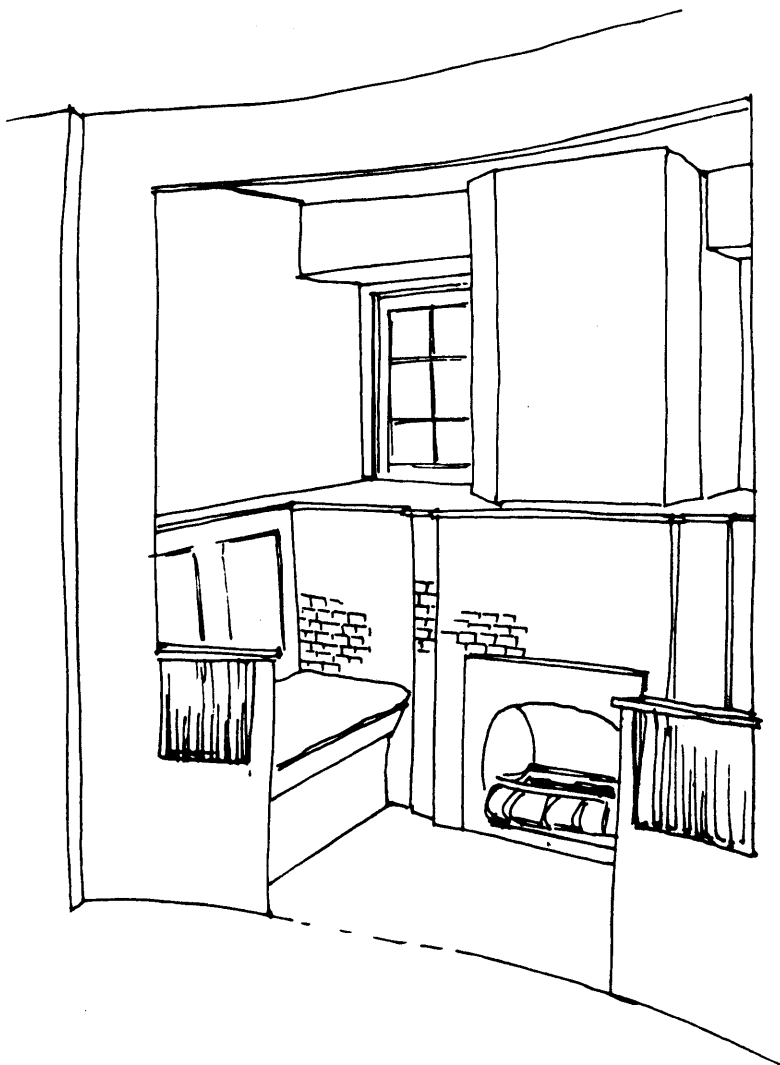

drawing 66

Fireplace in the Hall

drawing 65 - 66

associative form

1. Small sitting areas in drawings 65 & 66 are useable spaces defining the edges of larger spaces. Partial walls, columns, and low ceilings make these spaces more private than the larger associated spaces without isolating the spaces from one another. Within each of these spaces, nearby definitions are so designed as to be associative primarily to the smaller spaces, e.g. note the window sills/surfaces above the fireplace in drawing 66. Similarly, bookshelves and a ledge are built behind the seats in drawing 65. These "local" definitions allow the smaller spaces to be used in a manner different from the adjoining large spaces.
2. A unique interior relationship results from building windows in an opening to private rooms in drawing 65. The height and form of these windows is similar to window balconies found overlooking public streets. Since persons below can be observed by those above, the space below becomes more public.

comments

1. Larger spaces can be defined/limited by the association with smaller use spaces/definitions. These smaller spaces should not be considered independent of associated spaces since they determine use and association with the larger space.
2. Any space is defined by both its own physical form/definition/ uses and its association with all other spaces forming an edge of the space.

drawing 67

Library Room

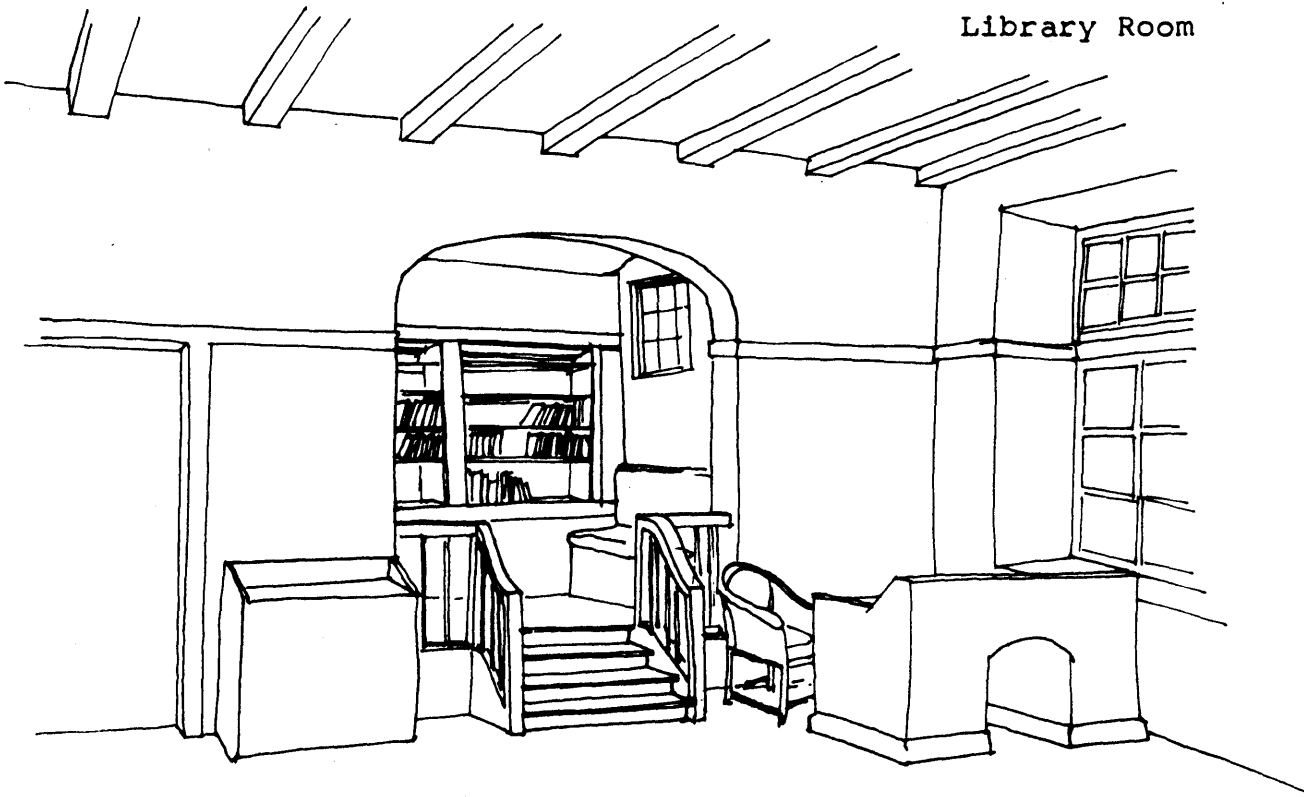

drawing 68

Day Room

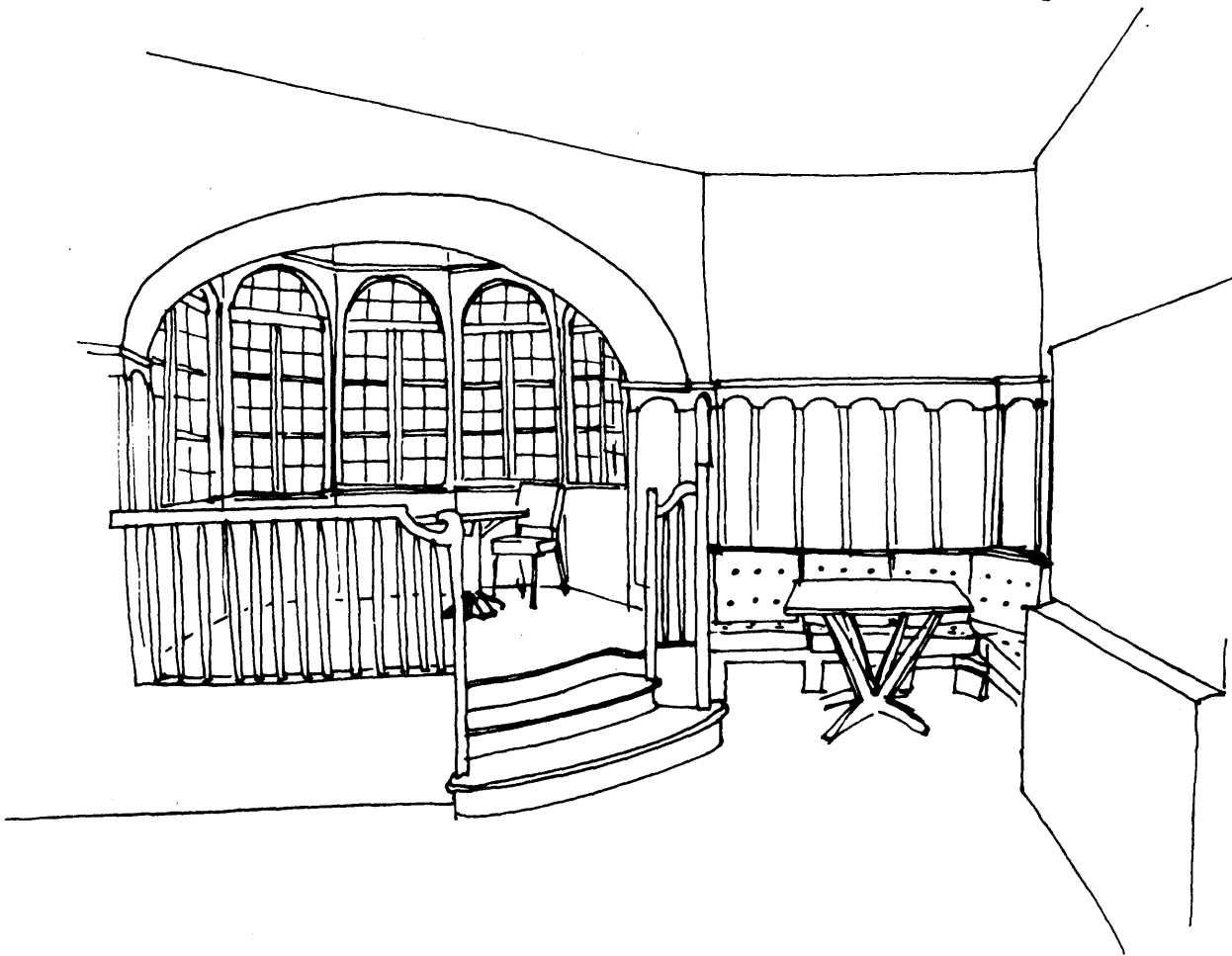

drawing 67 - 68

associative form

1. The raised sitting areas in drawings 67 & 68 differ in their association to the larger adjoining spaces. In drawing 67, the area that is raised is beyond an opening in the wall and though the two spaces relate visually, the raised space is useable as a semi-private space with reduced association to activities in the larger larger space. The raised floor and narrow stairs help identify the space as separate/private from the main space, limiting entrance. It is interesting to contrast this area with that in drawing 66. In this previous case, there was no level change, the fireplace was associative to both the small and large spaces. The result being a less private space.
2. In drawing 68, a sitting area/use space is extended to either side of the exterior wall with the raised floor extending into the interior space. In this case, there is little separation between the large space and the raised area, making the raised space less private. It is still possible to move through an arch/opening in the wall to a space exterior of the larger space. The degree of privacy in this case depends on where a person sits on the raised area and how big the area is. Although the access to the raised area is limited by stairs, the open railing maintains an association between spaces and further reduces the raised area's privacy.
3. The corner benches and table in drawing 68 provide a private place to sit within the larger space. Sitting with one's back to the wall affords security and control of the situation. Additionally, the table provides separation/protection from other persons in the space. The sense of containment by the raised area increases the privacy.

Comments

Associations with raised/lowered portions of the room are dependent on plan, section, and elevation / physical and visual access. Changes in any of these definitions affects the degree of association with surrounding spaces.



drawing 69

Music Room

drawing 70

Day Room

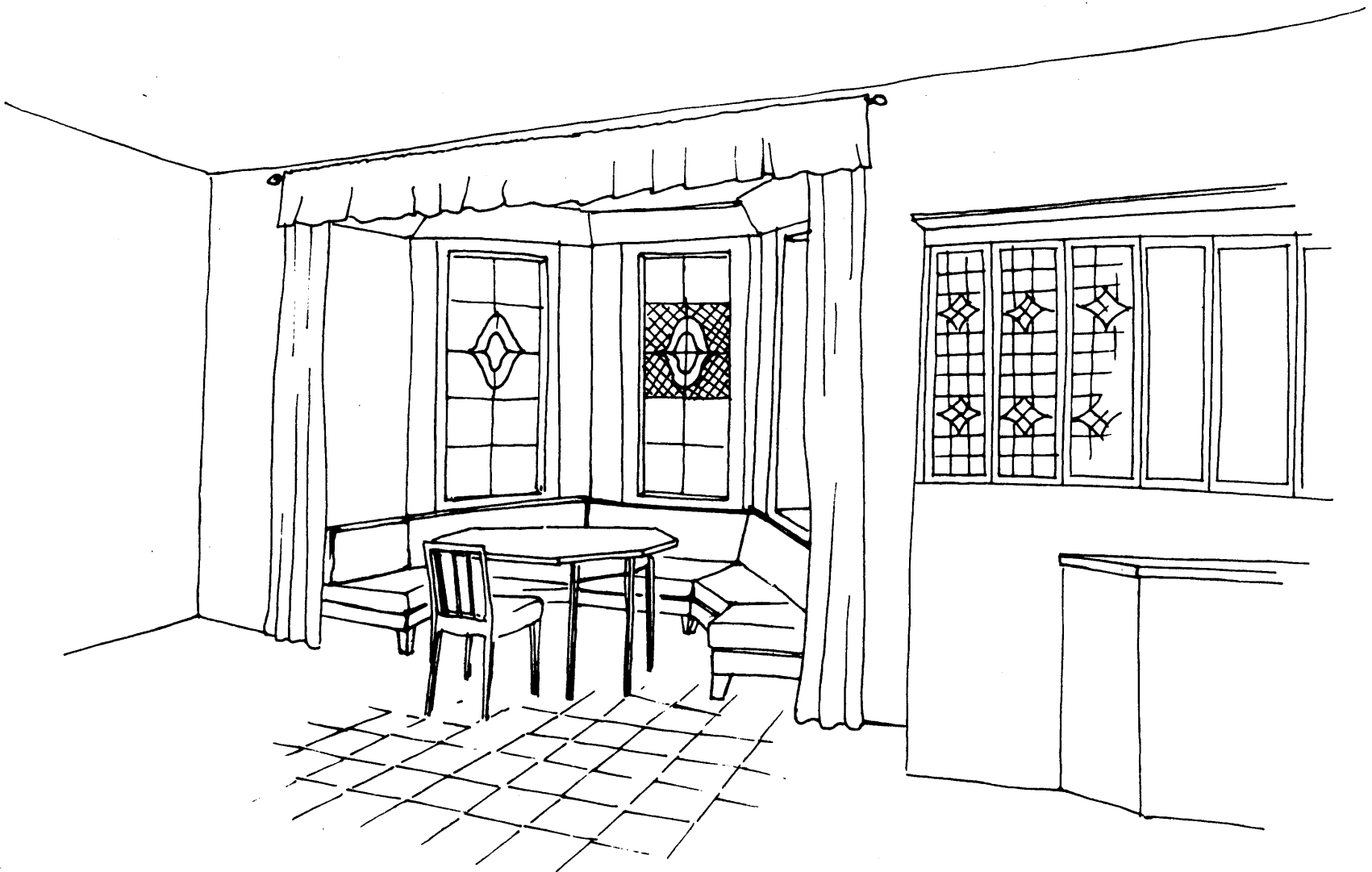



drawing 71

Central Hall

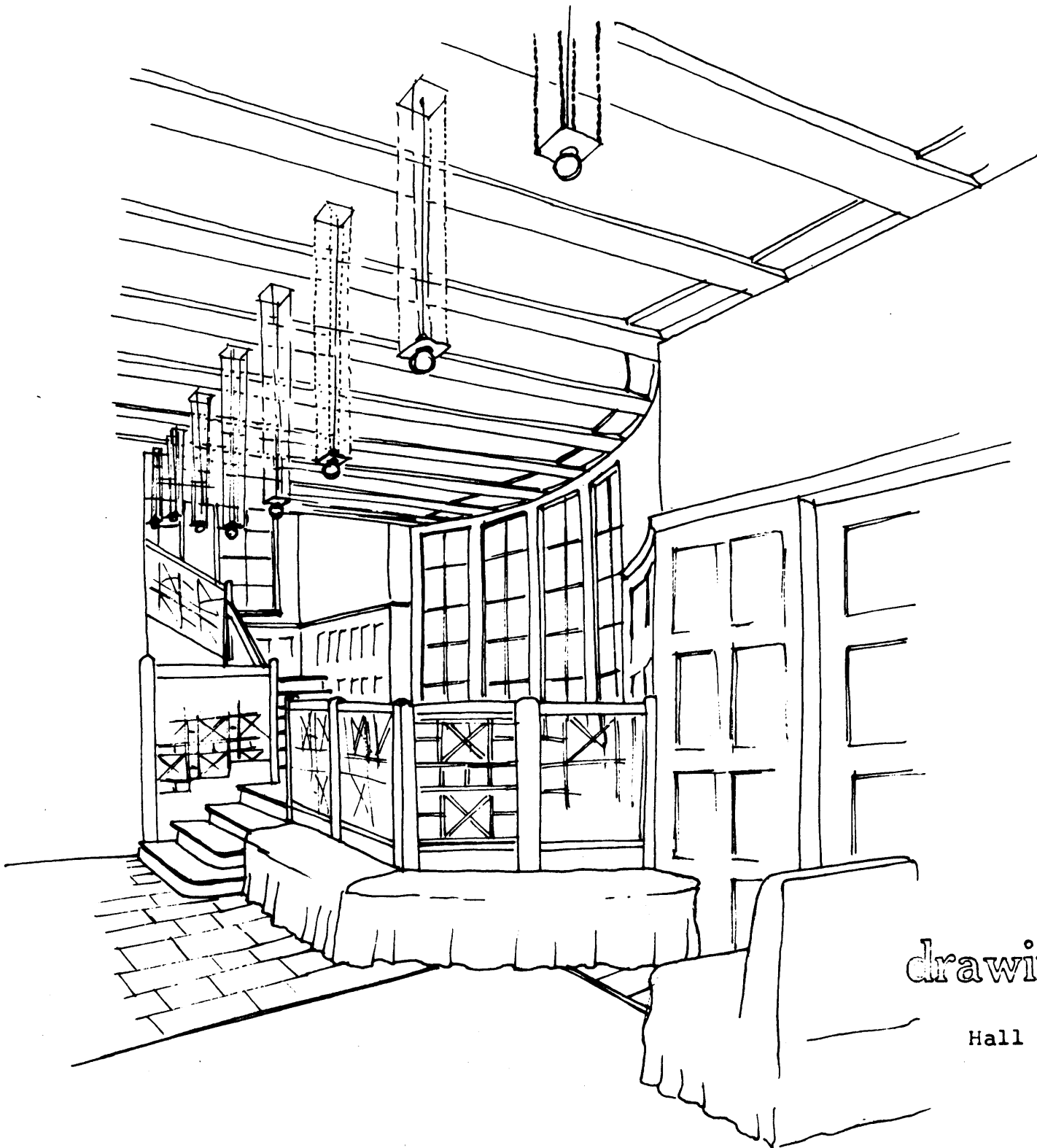

drawing 72

Hall

drawing 69 - 72

associative form:

1. In drawings 69 & 70, the bay windows with built in seating define spaces external of the main space, i.e. beyond the main defining walls. Because of lack of additional definition, there is only a small degree of privacy from the main space. Except for moveable tables and chairs, this bay form does little to define space in the larger space. The areas are readily open to visual and physical access.
2. Association with the bay space from the main room is radial to the windows or people. When sitting in the bay space, association with the immediate area is to direct attention to the center of the bay and back into the room.
3. In drawing 72, a bay window is built with a raised floor extending into the larger space. In contrast to the bays discussed above, a zone in and out of the main space is strongly defined. Within this zone there is strong association both out of the windows and into the main space. From the main space the association is with the raised zone/use space and then out the windows indirectly by virtue of the raised area's relation to the windows and outside space. The bench built at the edge of the raised floor provides a use zone/space at the level change.

Comments

A well defined use zone/space in an exterior wall allows strong association from that zone/space to both outside and inside spaces. Moving an exterior wall into outside space with a minimal interior definition produces only a minimal association with outside space.

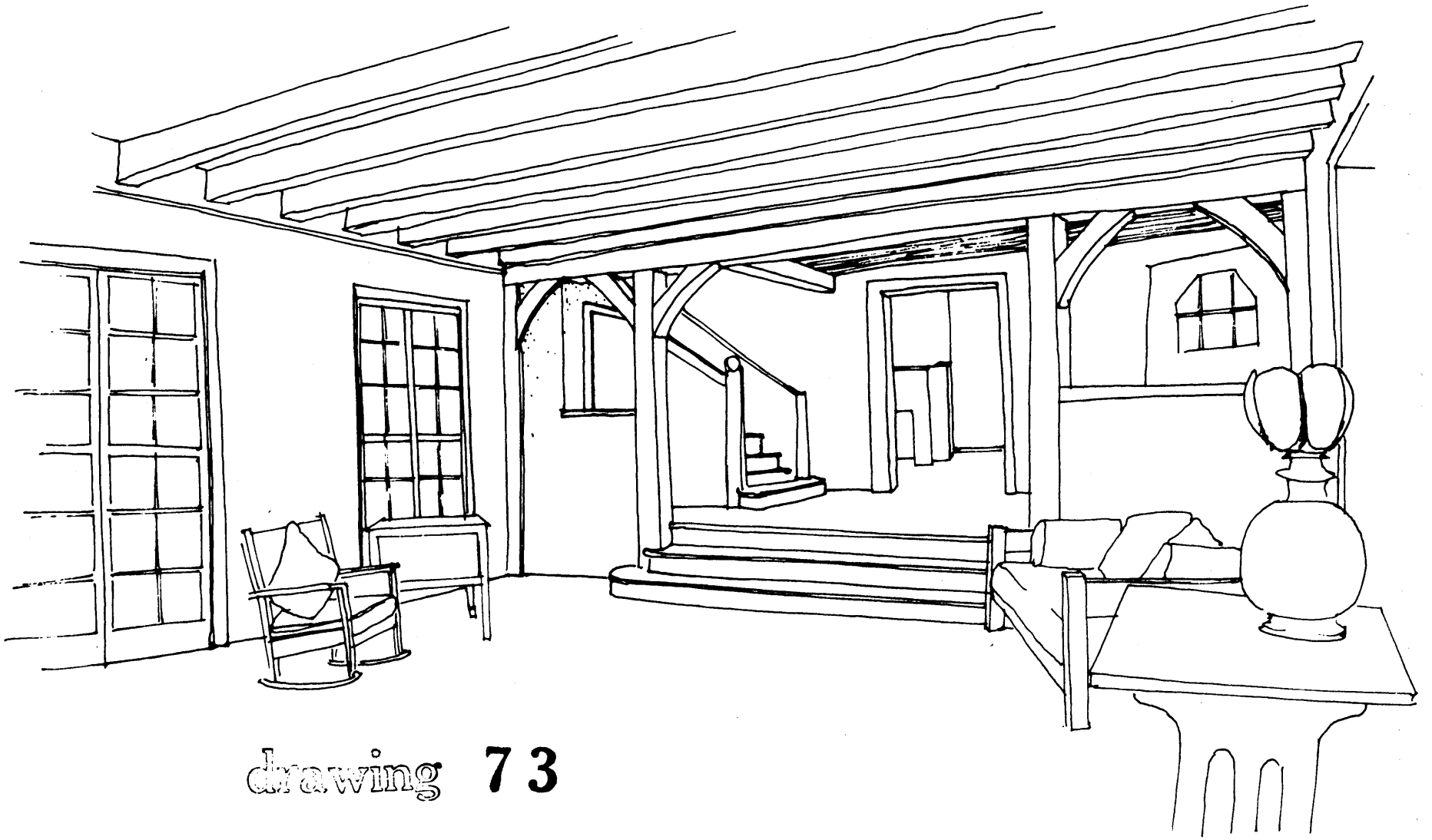

drawing 73

Central Hall and Entrance

drawing 74

Central Hall and Fireplace

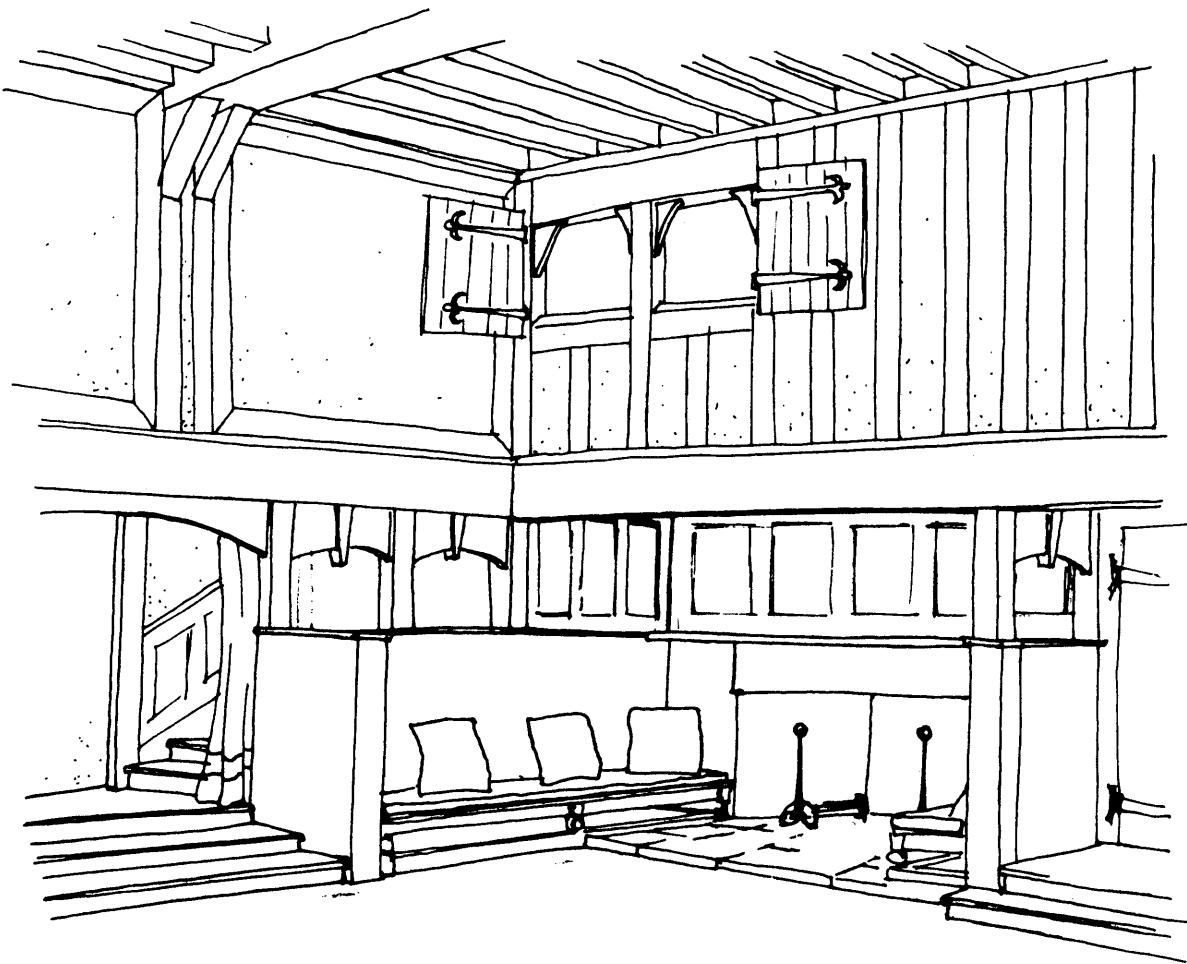

drawing 71, 73 - 74

associative form

1. Entrances in drawings 71, 73 & 74 allow association with the main spaces from a higher level. These spaces, defined by partial walls, columns, and stairs, allow persons entering the room/space to see many directions and to determine the nature of the space they are about to enter. In each example, lowered ceilings over the entrance spaces give the spaces some privacy from the main space. The small entrance spaces are limited in use by persons potentially entering and leaving. The larger entrance spaces can accommodate more people and a wider range of potential activities/uses. The wide stairs in drawings 73 and 74 allow a more direct association between spaces at different levels decreasing the relative privacy between spaces.
2. When raised levels are of sufficient size or number and the level change is not too great as in drawings 73 & 74, the lower level obtains an association of being contained/defined by higher levels. Such containment allows a feeling of security/a sense of place.
3. In drawings 71 & 74, upper floor levels define spaces below. In the one case, a large fireplace hearth is covered and the resulting space is utilized as a semi-private sitting area associated with the main space. The material change of the hearth and the 6 inch level change help to define this space/area as a separate use space/zone. As a defining edge of the main space, close association between the sitting area and main space is maintained by extending a bench from the fireplace into the larger space. The bench may be used by those in the large space or those sitting next to the fireplace in the smaller space.

comments

Association between levels 1 - 3 feet high varies depending on treatment of the edge/spacial-edge between levels. Narrow stairs increase separation of spaces; wider stairs and use zones/spaces/edges can increase association between levels. Depending on design, lower level spaces can have an association of containment/security.



drawing 75

Work Rooms

drawing 76

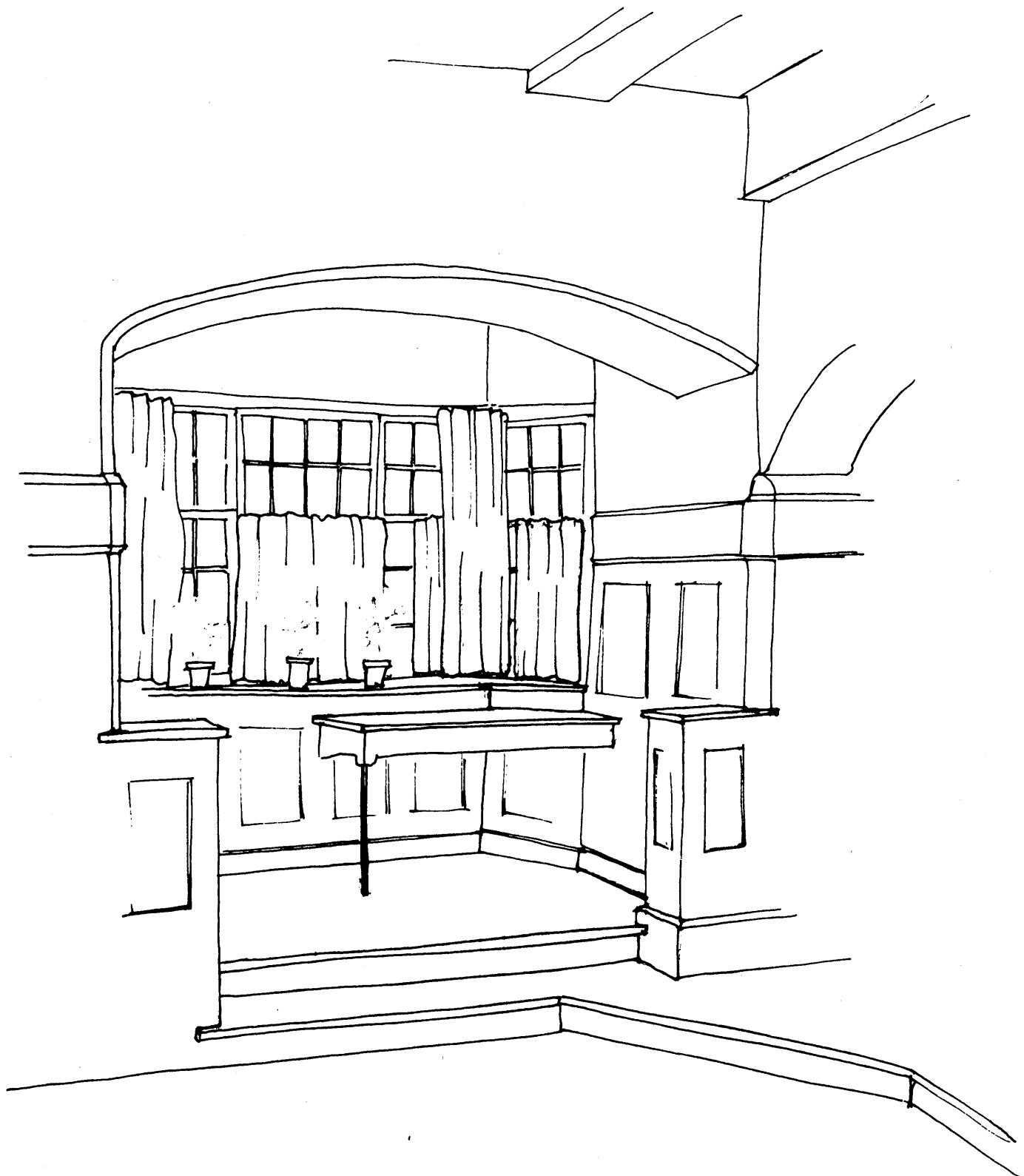

drawing 75 - 76

associative form

Small level changes, 6 - 12 inches, in drawings 75 & 76 are used to separate the uses of the various spaces. Each level in the space accomodates separate functions while maintaining easy visual association between functions, through the large openings. It is significant that these level changes occur/are associated with the wall openings. This strengthens the zone of the opening as a zone/space of change.

comments

Used in association with other built definitions, small level changes introduce or strengthen changes in use/activities between adjoining or continuous spaces.

drawing 77

Stairway

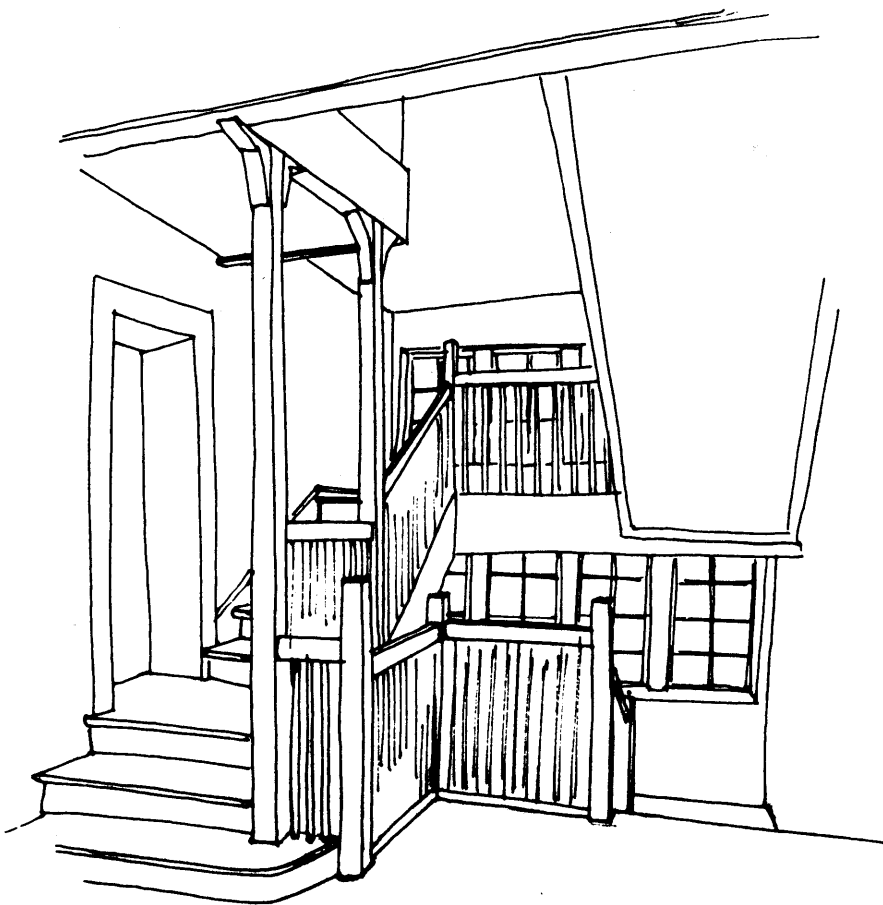

drawing 77

associative form

The stair case in drawing 77 is formed by a series of associative spaces, each large enough to accomodate a use. Halfway between floors, windows are built with wide sills allowing placement of objects and operation of the windows. Sills appear to be sufficiently wide to allow persons to sit or lean. At the landing, the railing defines a larger space to the side of the stairs providing sufficient space for several persons to stand without blocking the stairs. Partway up to next set of stairs is a short landing which, in association with the wall depth and overhead landing, forms an entrance space to a room.

comments

Stairs can be a spacial connector between associative spaces and places. The stairs themselves associating with the spaces they connect.

JAPANESE USE OF HOUSE SPACES

Reception-Room & Guest Chambers

- principle room with ante room
- faces garden
- surrounded by veranda
- contains: TOKONOMA - picture recess
TANA - cupboards and shelves
SHOIN - projecting bay windows
- serve guests dinner

Living Room

- main family room
- bedroom/study
- can serve as a reception room

Dining Room

- for family dining
- alternately, a small reception room

Tea Room

- for tea ceremony

Veranda

- most important space between living room and garden
- in summer it is a light subdueing ante-room
- in winter it is a warm place
- it serves as a corridor

Kitchen

- raised portion is for utility/cooking
- lower portion is for entry and delivery of food
- food storage under raised floor

Bath

- used to warm body
- wash next to the tub

Entrance Hall

- place to remove shoes
- prior to ante room
- generally 1'-8" lower than ante room
- entrance generally at right angles to path from street

Ante Room

- meet guests
- maids room
- nursery

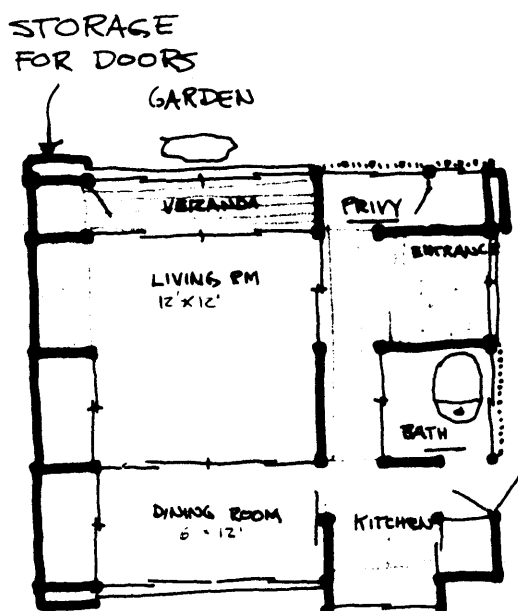

drawing 79

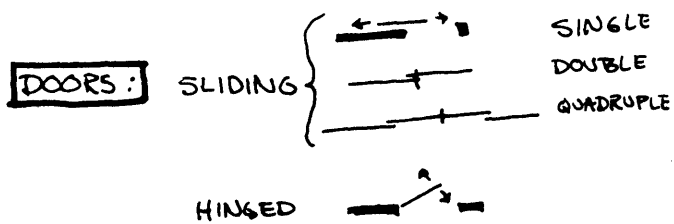

NOTE: MANY SLIDING DOORS/WINDOWS ARE REMOVABLE FOR SPECIAL OCCASIONS AND WEATHER CONDITIONS

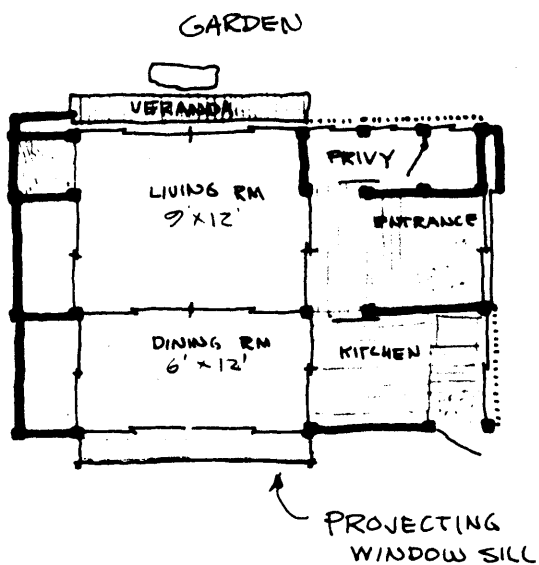
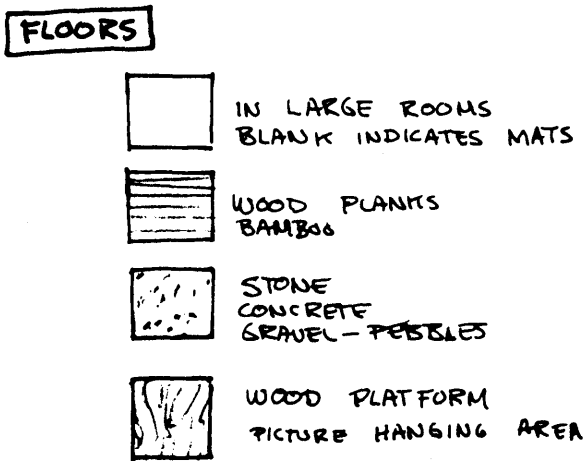
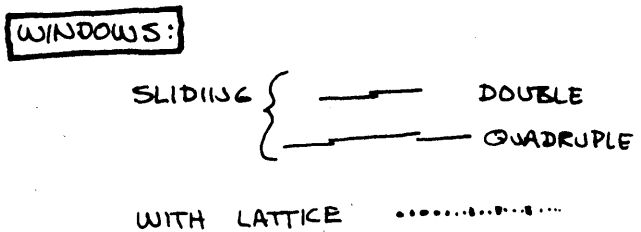

drawing 80

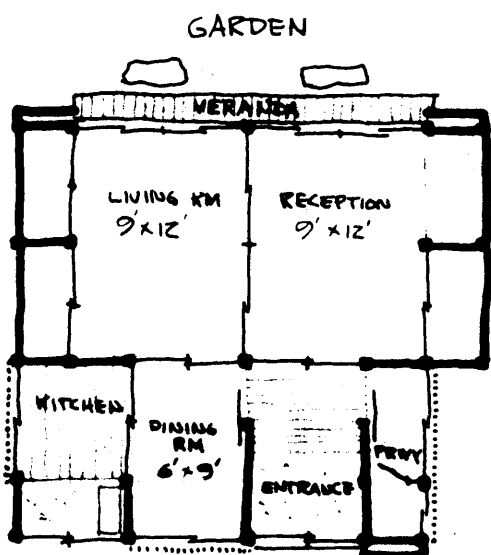

drawing 81

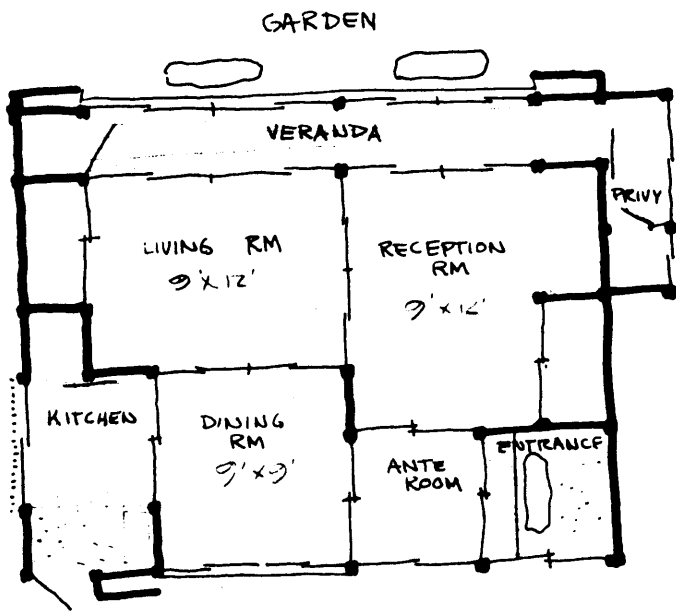

drawing 82

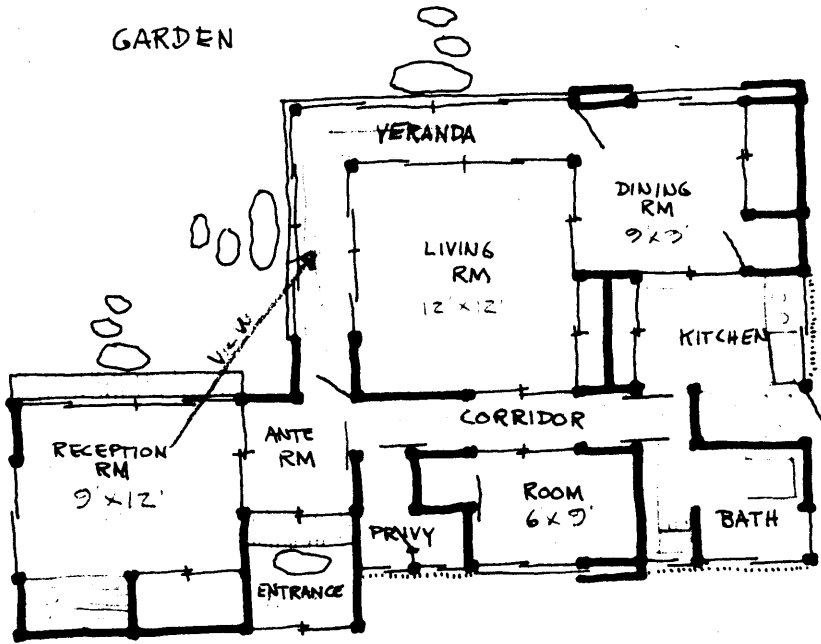

drawing 83

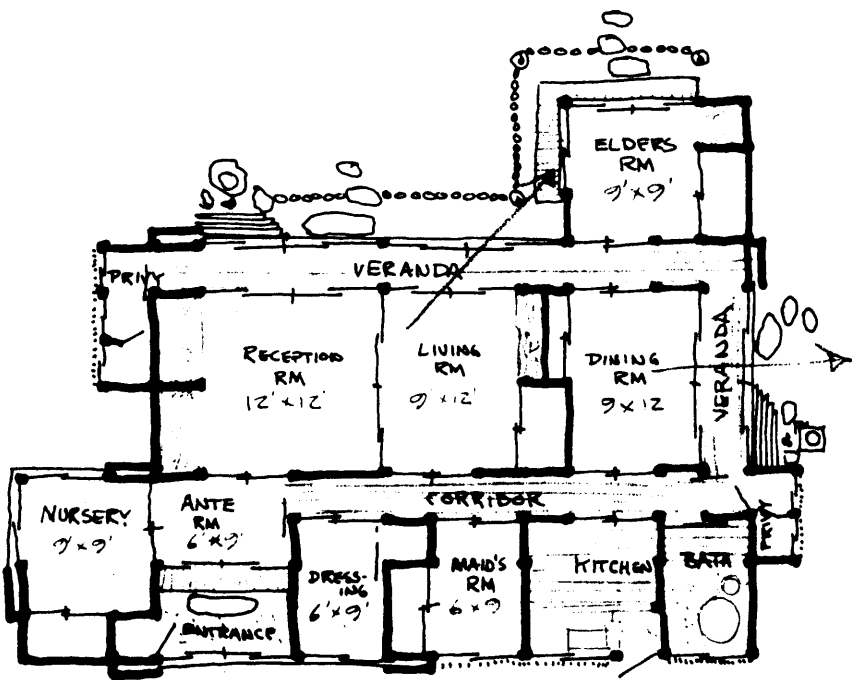

drawing 84

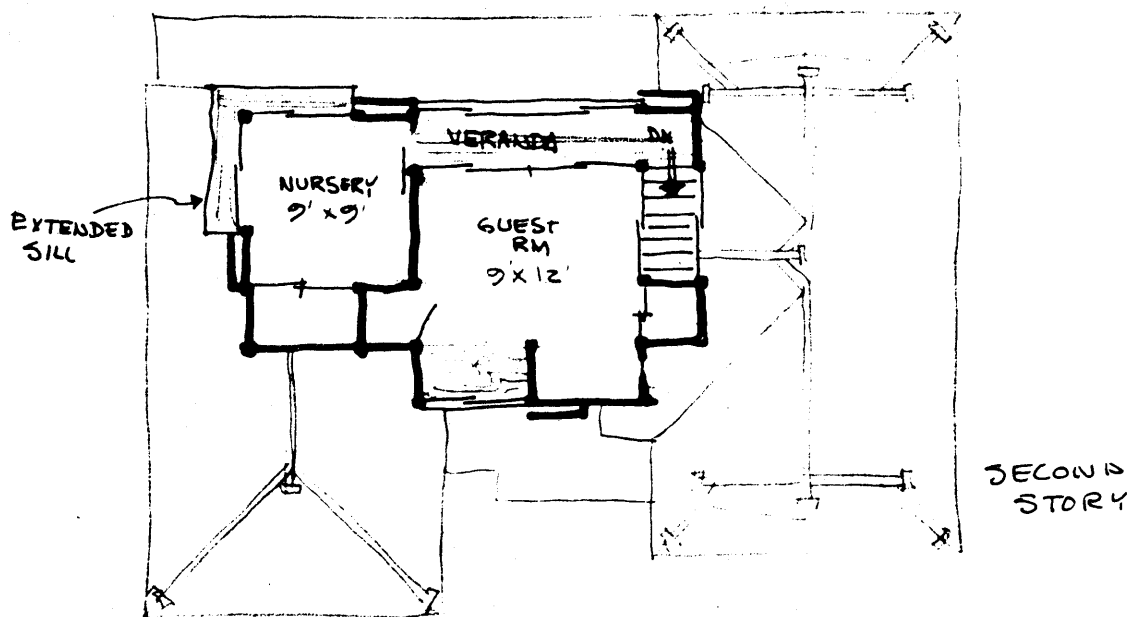
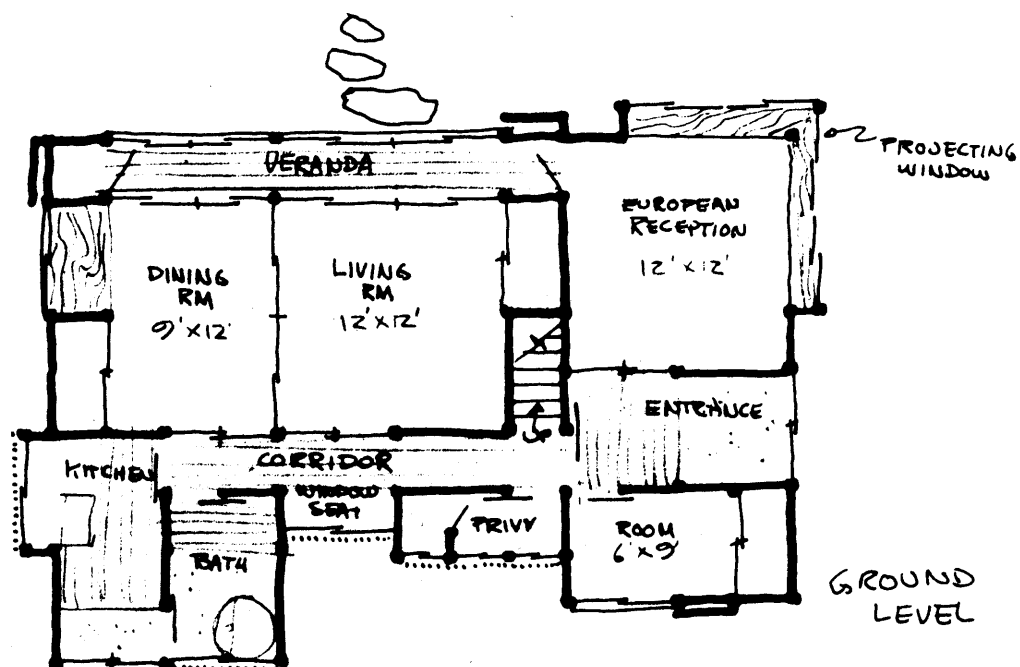

drawing 85

drawing 78 - 85

associative form

1. The plans of Japanese houses, drawings 78-85 represent a range of plans from the simplest two room house to the multi room, two story house. These plans are of interest in that all indicate associations with outside spaces and associations between interior spaces not previously discussed. In analyzing any of these plans it may be assumed that any of the sliding doors/windows may be opened varying amounts, including full removal at certain times. This flexibility permits utilization of the spaces in a large number of ways throughout a day and throughout the year. Independent of position of doors, it is clear that most of the houses can be associative as an assemblage of related spaces. Movement through the house is from one space to the next rather than along corridors connecting spaces, although several of the houses do have minimal corridors.
2. On a local scale it is clear that individual spaces within the houses are defined by various repetitive/associative elements. These include sliding doors/screens, closets, wall recesses, cupboards, and various window openings. Impenetrable wooden walls (dark lines) are held to a minimum. Association with each of these elements is discussed in reference to drawings that follow.
3. Common to many of the plans is the distribution of use zones/spaces along the outside edges of the buildings, i.e. closets, picture hanging recesses, verandas, window seats, and projecting window sills. This not only makes a spacial edge/zone for the inside spaces, it also allows interior spaces to be directly adjacent, associating through sliding door openings. For example, in plans 80 & 82, the major living areas are adjacent to one another in the middle of the house. In the living and reception rooms one outside wall is defined by closet spaces and a recess. Another wall opens to the veranda and associates with the outside space through the veranda. The interior walls of these rooms are defined by doors/screens to other living spaces. In both plans, the kitchen, privy, and entrance spaces are special use spaces and are located on the outside edge of the living areas. When living space windows do open to the outside, projecting window sills may be defined as

in the dining room, drawing 80.

4. The veranda, present in all plans, requires special attention because, in most cases, any relation/association with the ground outside is through a veranda. It is also one of the most variable spaces in the house. In most plans, the veranda forms a variable use zone/space/edge along one or two sides of the living spaces. It is identified as a separate space by virtue of the roof/ceiling detailing, change in floor material and dividing doors/screen. When all the doors/screens are open or removed, the association is to move or direct attention across the narrow dimension to the space beyond. If the inside doors/screens are partially or fully closed, the veranda is associative as an outside covered porch. Movement is directed along the length from opening to opening and attention is directed outward to the outside space. If the outer doors/screens of the veranda are closed and the inner doors open, the veranda becomes a semi-private use space associated with the living areas. The protection from weather extremes afforded by the veranda is discussed in reference to drawings that follow.
5. An interesting design characteristic of the plans illustrated, is that acoustical privacy between major living spaces is attained by separation of two spaces by another space rather than by thick sound proof walls or doors. Note in drawing 84, the nursery is private in that it is associated with the rest of the living areas through the ante room. Similarly, the elders' room is separated by virtue of the veranda corridor space. The dining room is isolated by two corridor spaces and built up closets toward the living room.

comments

Japanese houses are an assemblage of spaces defined by repetitive spacial and planar definitions. Structurally a post & beam system with lightweight infill walls, spaces/use zones must be defined by actually building the space with multiple walls, doors, screens, etc.. Very little spacial form/use zone is derived from the dimensions of the basic materials and building system. With regard to this, Japanese houses serve as a rich source of design for lightweight wooden frame houses constructed in the United States.

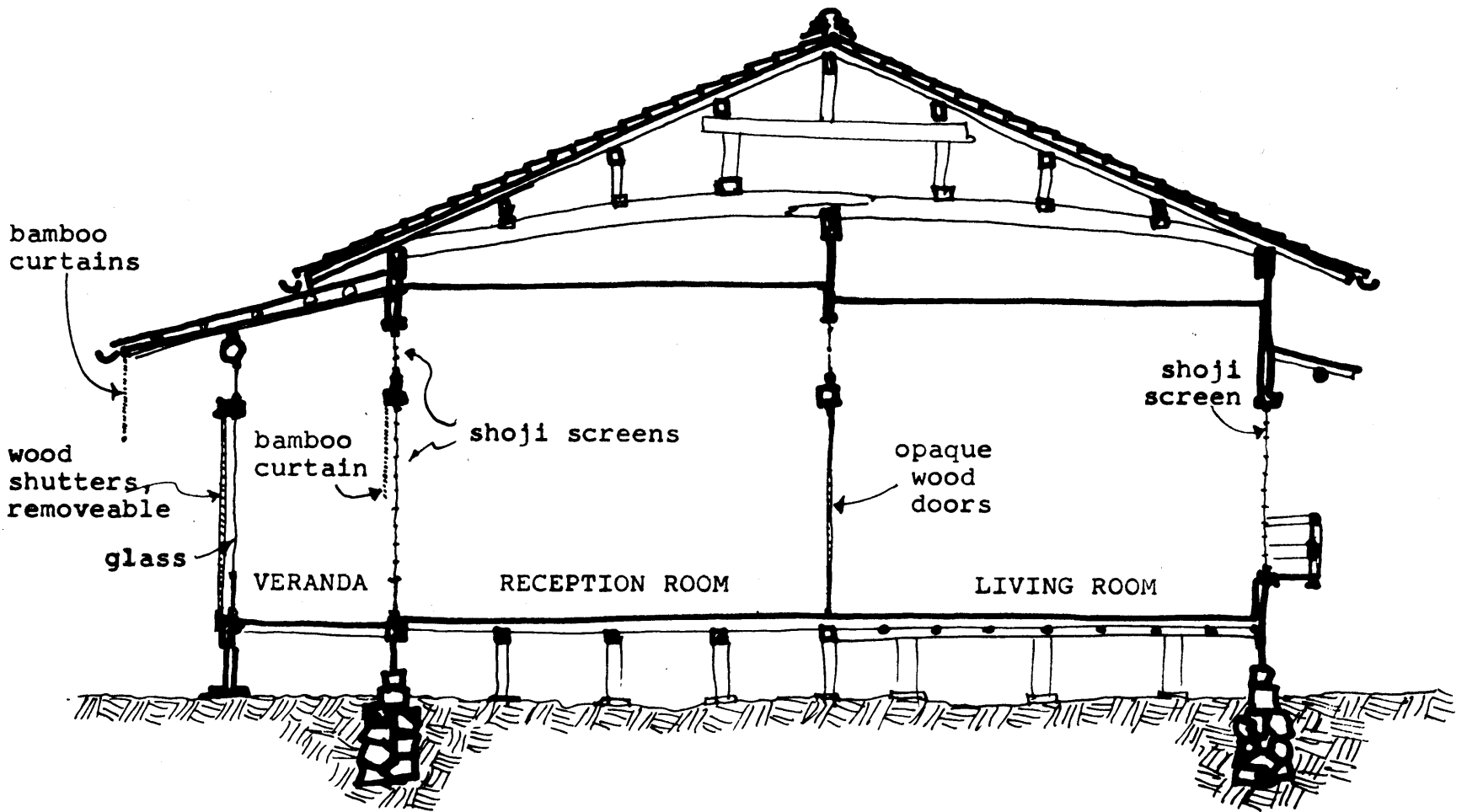

section

drawing 86

One Story
Japanese House

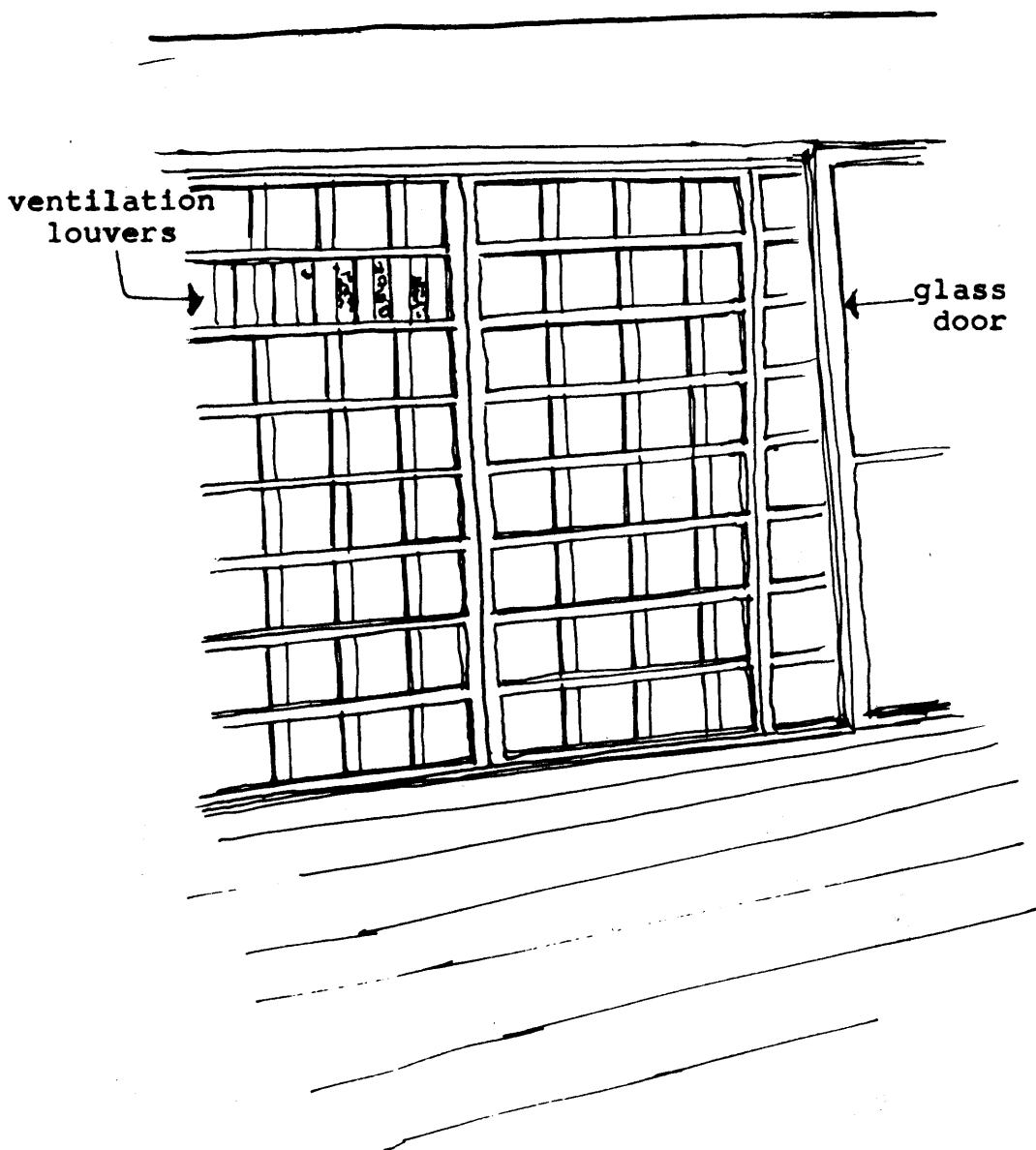

drawing 87

Wooden
Doors/Shutters

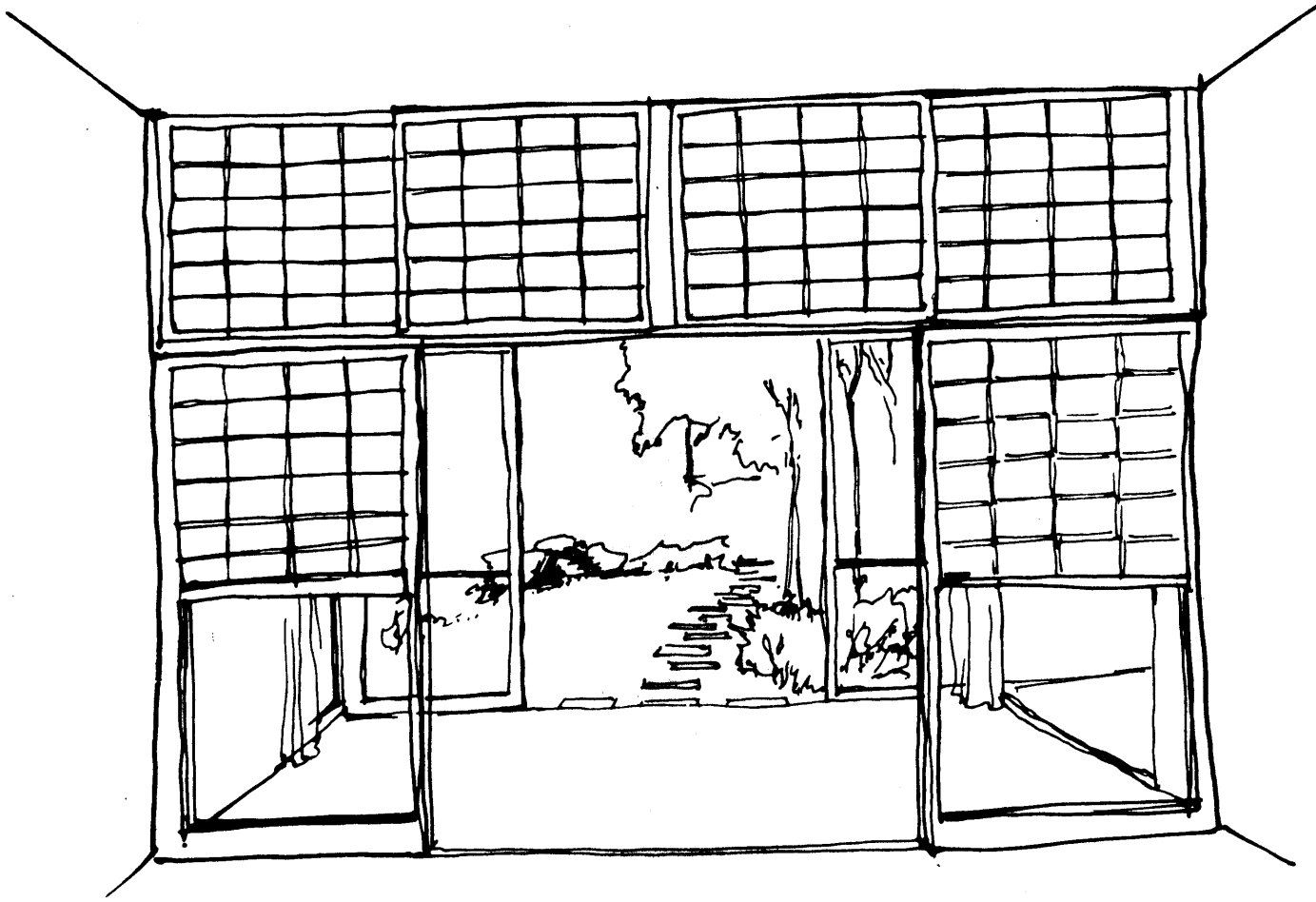

drawing 88

Shoji Screens and Glass Doors

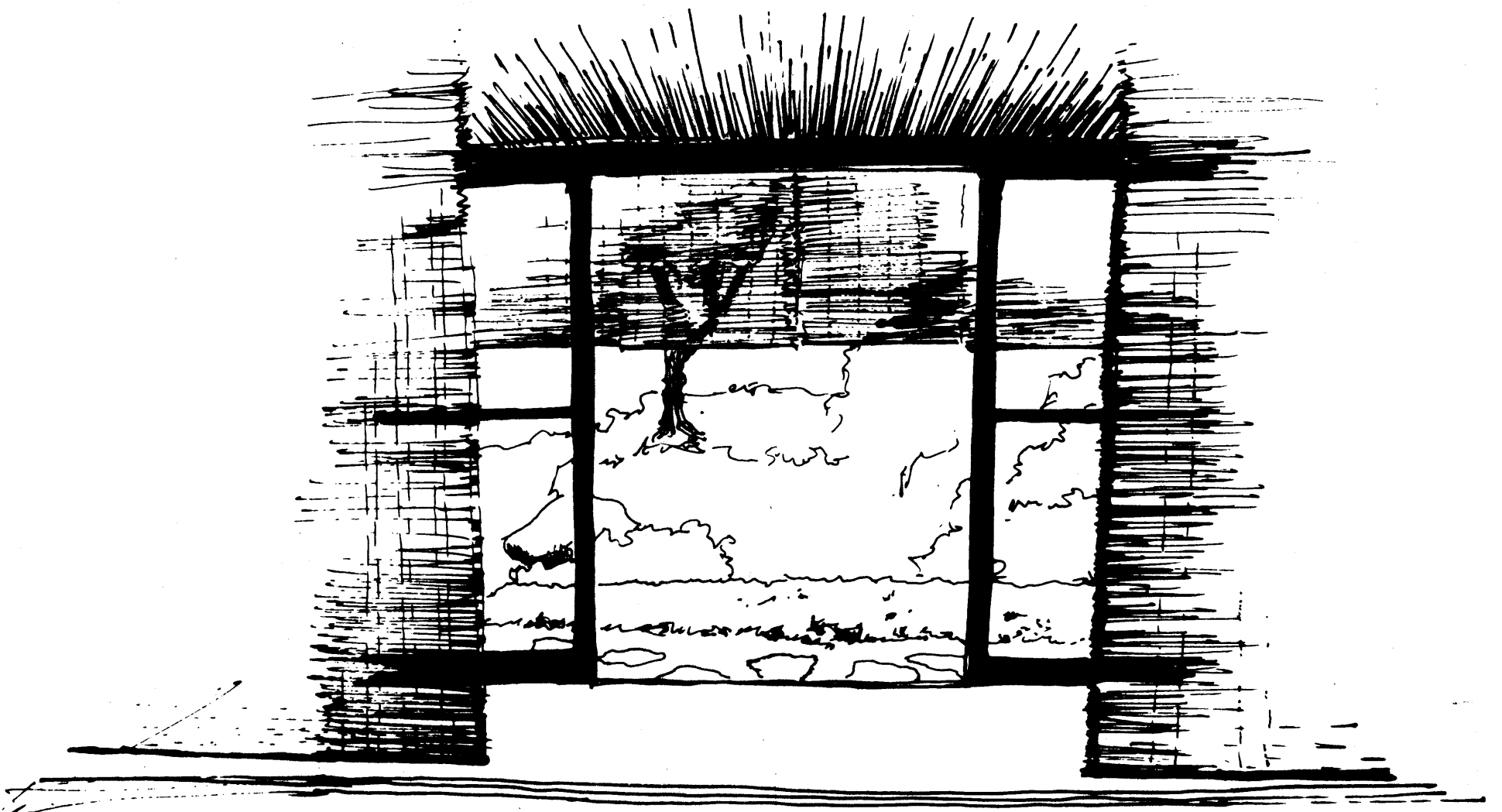

drawing 89

Bamboo Curtains, Summer

drawing 86-89

associative form

1. The section of the Japanese house in drawing 86 indicates that the house is structurally a post and beam system. Walls, windows, screens, and doors are lightweight definitions assembled within the larger post and beam framework. Association with the house from both interior and exterior is that it is a raised platform covered by various spaces affording a range of privacies.
2. Illustrated in drawings 87 to 89 are methods used to close or partially close/protect the veranda and interior spaces. Wooden shutters/doors may be drawn across the outer edge of the veranda providing security/privacy at night and protecting from severe weather. During the day, these shutters may be stored in spaces provided to either side of the veranda. Glass doors, also on the outer edge of the veranda may be closed for weather protection and to allow solar heating by the low winter sun. Between the veranda and living spaces, shoji screens (lightweight wood frames with paper cover) allow adjusting the desired degree of privacy between the living spaces and veranda without eliminating light. In drawing 88, the lower half of the screens may be lifted to provide ventilation and allow visual access to the veranda. Door frames and upper panels still define the extent of the living space, maintaining a semi-private association with the veranda. In drawing 88 note that the screens over the door may be opened for ventilation without affecting visual privacy. During summer months, keeping the house cool by air movement is facilitated by replacing the shoji screens with bamboo curtains, drawing 89. Similarly, curtains are hung beyond the outer edge of the veranda. The bamboo curtains allow screening of bright light from the spaces outside and allow limited vision through the curtain from the dark side to the bright side. Privacy is maintained without sacrificing air flow and view.

comments

The variety of full/partial closure possible allows adaptation of the house to weather extremes and permits utilization of

natural ventilation, light, and solar heat when required. The amount of privacy desired may be provided without sacrificing ventilation and light. A large amount of flexibility and capability is provided by locating the screens, doors, and curtains in a spacial zone at the edge of the house, i.e. the veranda.

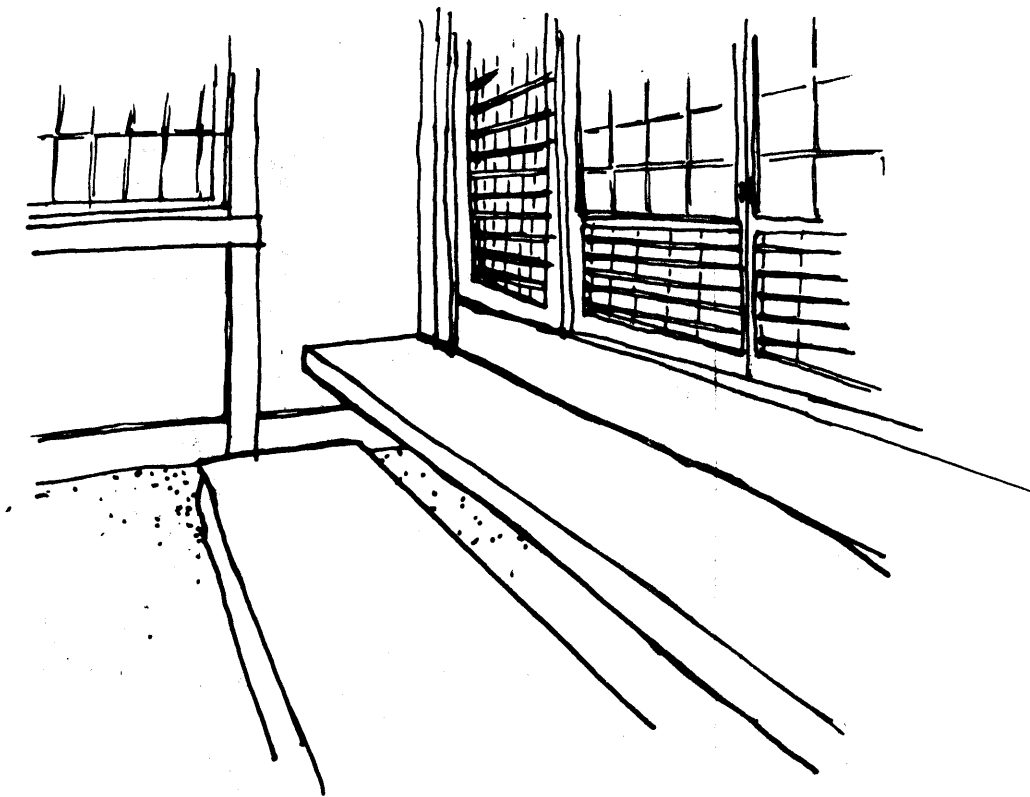

drawing 90

Entrance Room

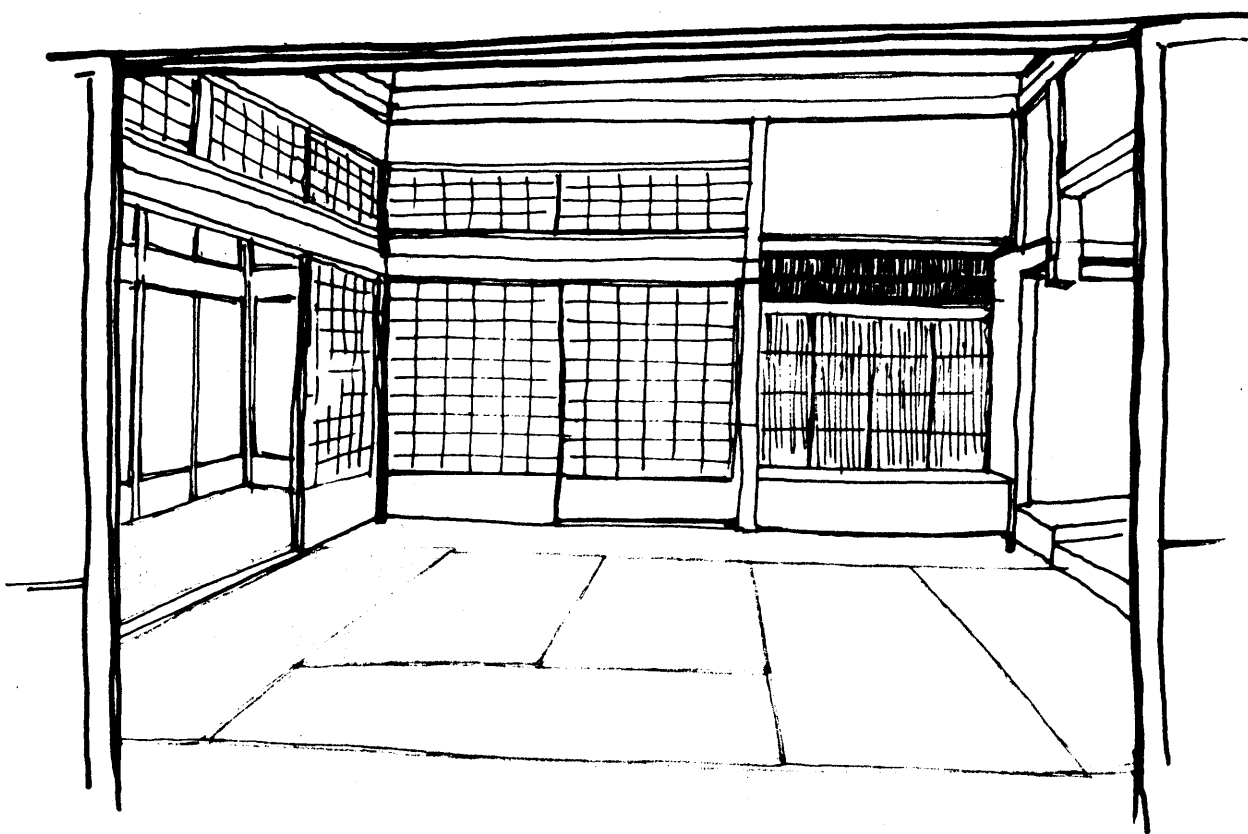

drawing 91

Reception Room,
Veranda

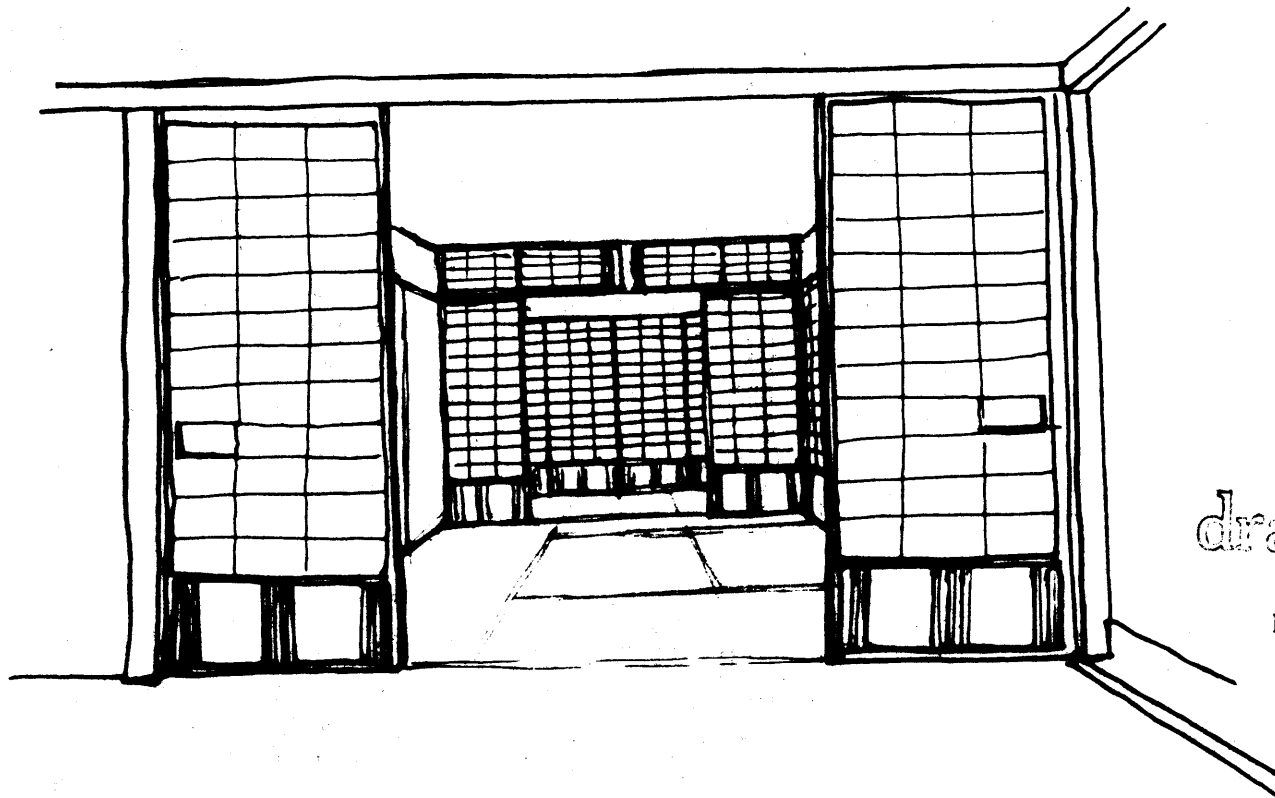

drawing 92

Reception and
Living Room

drawing 90 - 92

associative form

1. The entrance space is generally an enclosed outside space. In drawing 90, the enclosure is over ground level, the ground surface being gravel, stone, or concrete associated with walking on a path outside. The ante room floor level is the bottom of the doors. Two intermediate levels are provided to allow access to the upper floor level. The large stone, associated with the ground is the first step and provides a platform on which to leave shoes. The next level is a wooden ledge. Wood in this context is associated with the floor beyond and walking without shoes.
2. The reception and living rooms in drawings 91 & 92 illustrate the interior association between spaces through the door/screen openings. Shown in drawing 91 are a window seat and a picture hanging recess. Note the adjoining level change between the spaces. occurring at a room opening, the level change indicates a change in use/space without obstructing visual association between spaces.

comments

Careful use of materials at the entrance allows independent association with the ground level/use and the living spaces/uses: ground materials used on the ground - soft building materials used for floors, doors etc.

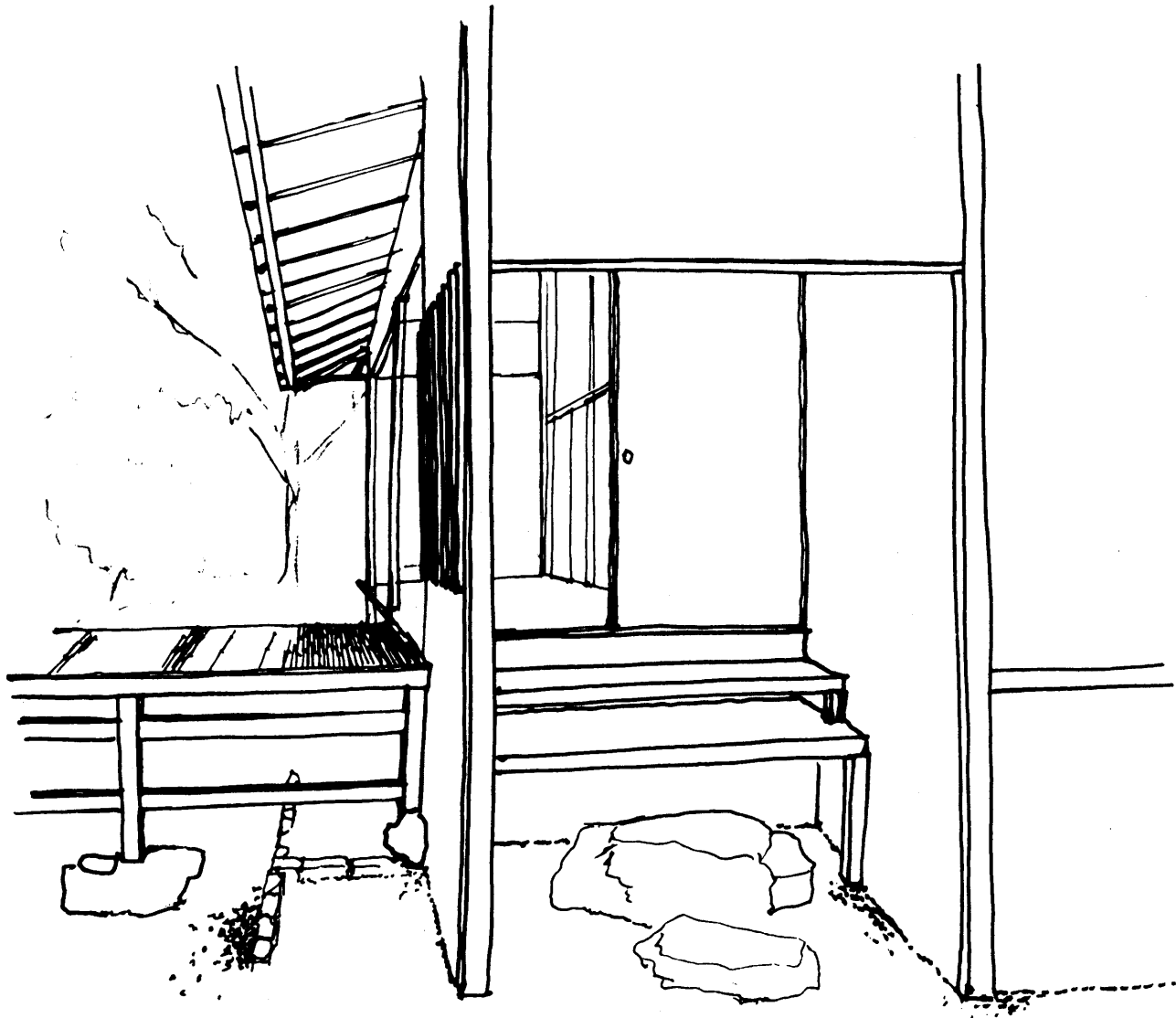

drawing 93

Veranda Entrance

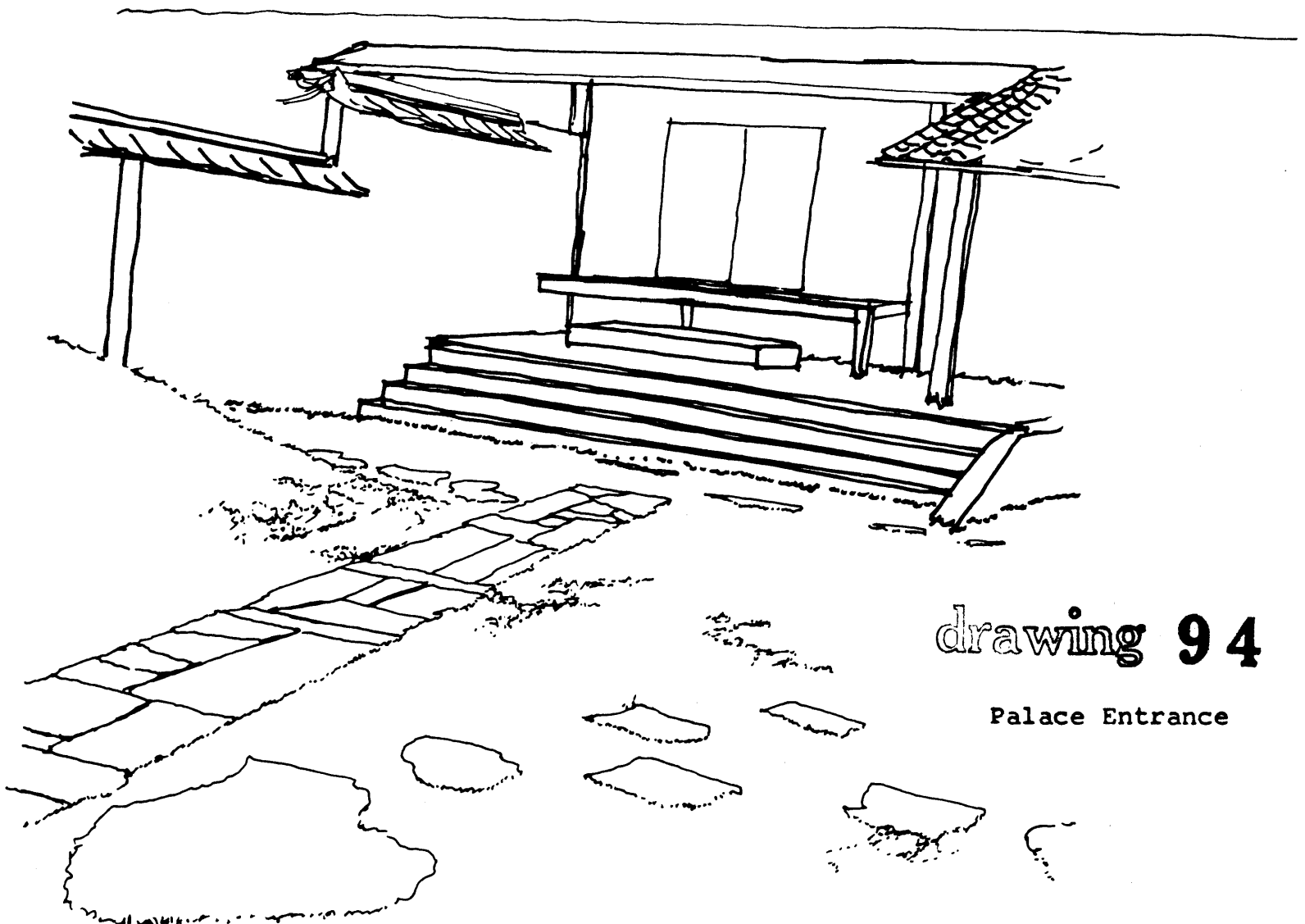

drawing 94

Palace Entrance

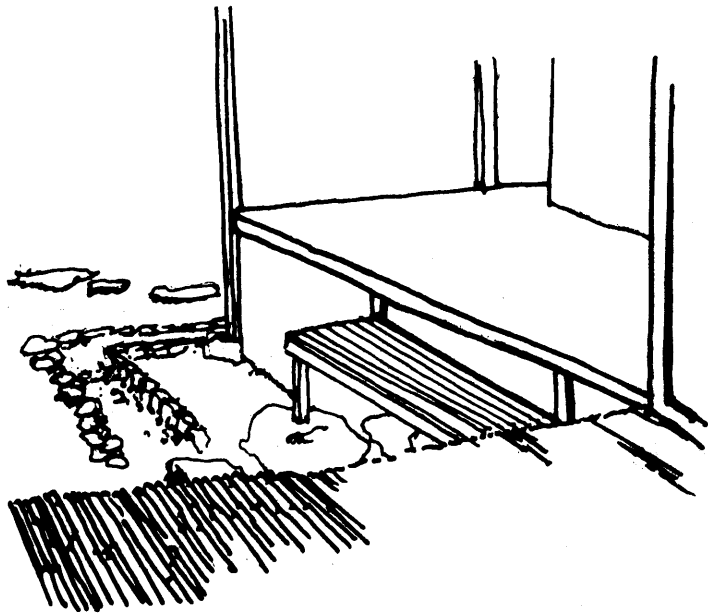

drawing 95

Veranda

drawing 96

Veranda

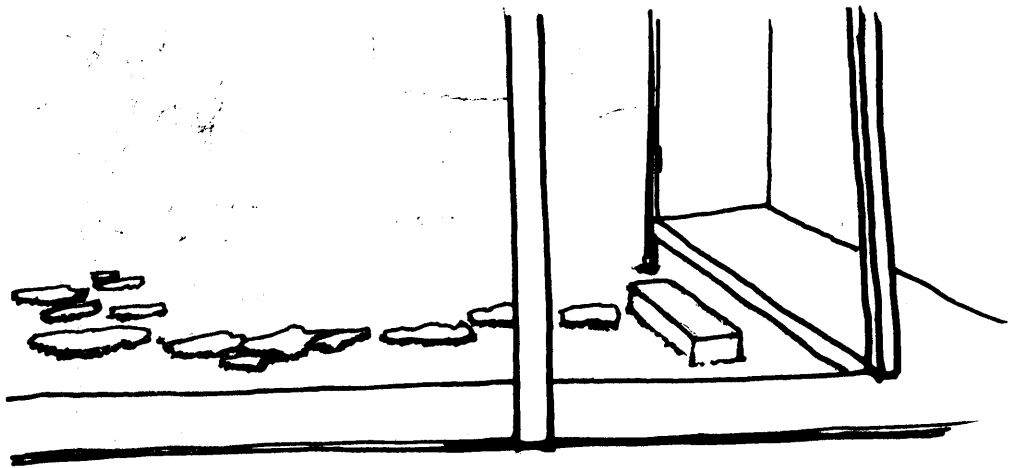

drawing 97

Veranda & Garden

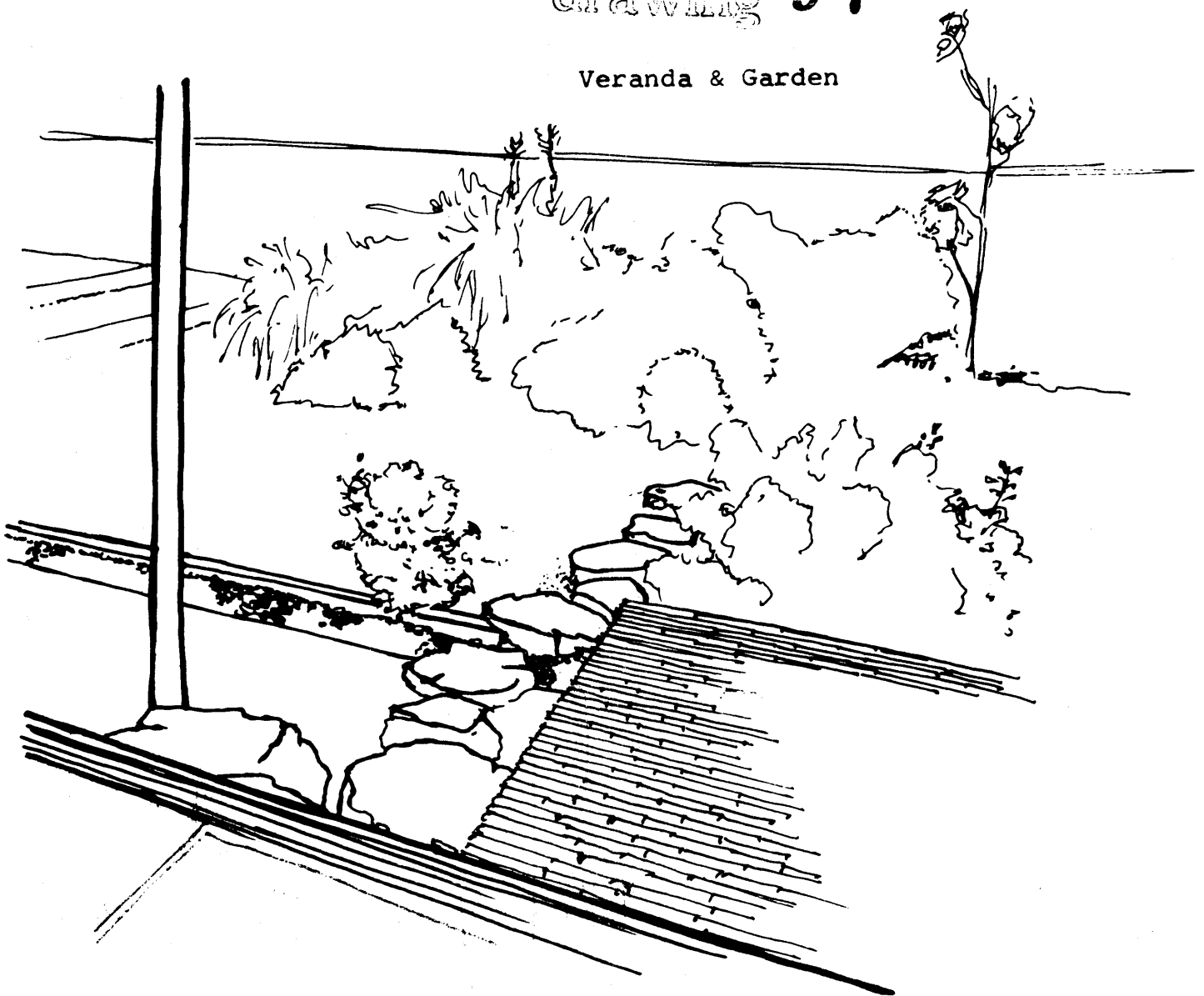

drawing 93 - 97

associative form

1. Ground form in the immediate vicinity of the house is generally built up, smoothed, or controlled in some manner so as to provide an area onto which the house can be built. In drawings 93, 95 & 97 a small trench of pebbles is located under the roof edge to catch rain runoff. Within the circle of this trench is the house, beyond is the garden, yard, etc. Note that stepping stones cross this trench and provide an elevated/dry walkway connecting the house to/through the garden.
2. Exterior walls which rest on the ground define an exterior space in the near vicinity of the wall. The ground becomes a floor in association with the built definition. In particular, the walls in drawing 93 are built down to or on top of the ground forming an entrance space and spaces associated nearby. In drawing 94 exterior walls are extended to form a large exterior space for the entrance at the top of the stairs. Even short walls define space as illustrated in drawing 95.

comments

1. Any wall defines associative space on both sides. If a wall is an outside wall of a building it defines space both inside and outside.
2. Design of the outside edge of a building includes the association with spaces exterior to the building. As a person associates with built form/definition within a building, so does he associate with built form/definition on the exterior of the building.
3. Association with a building's spaces/definitions includes:
 - i. interior spaces associating with other interior spaces
 - ii. interior spaces associating with exterior spaces
 - iii. exterior spaces associating with interior spaces
 - iiii. totally exterior spaces



drawing 98

Windows

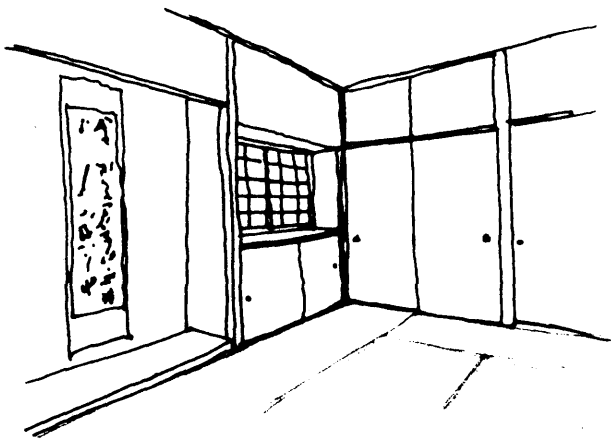

drawing 99

Picture Hanging Recess
& Window

drawing 100

Windows, Glass &
Paper Screens

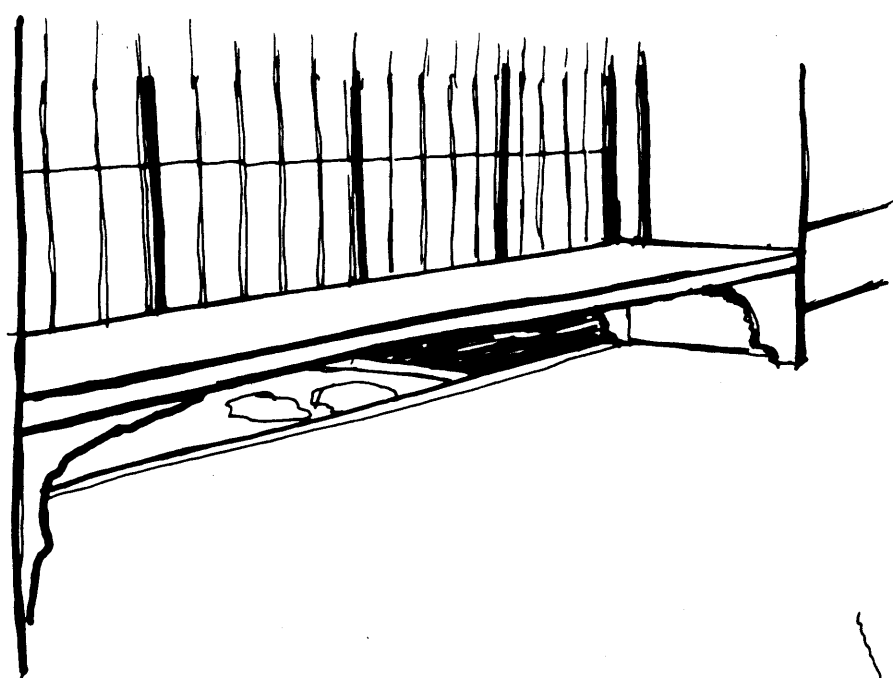
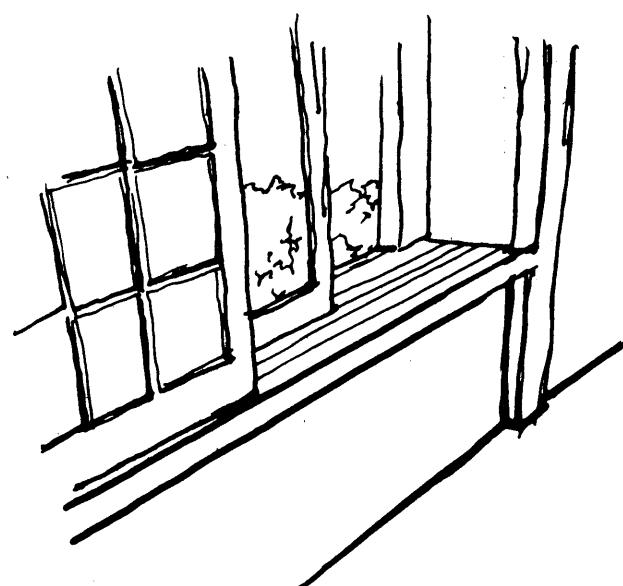

drawing 101

Window Seat

drawing 102

Window & Ventilation
Louvers

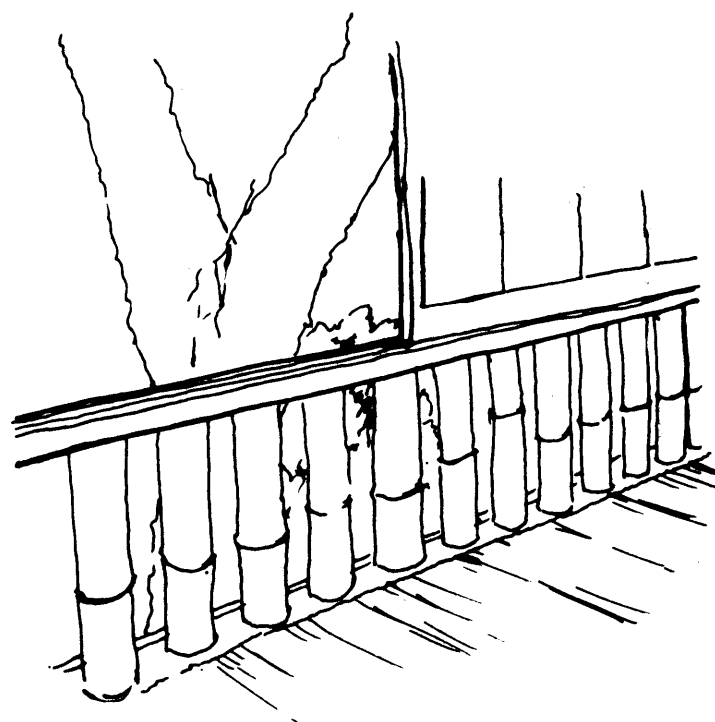

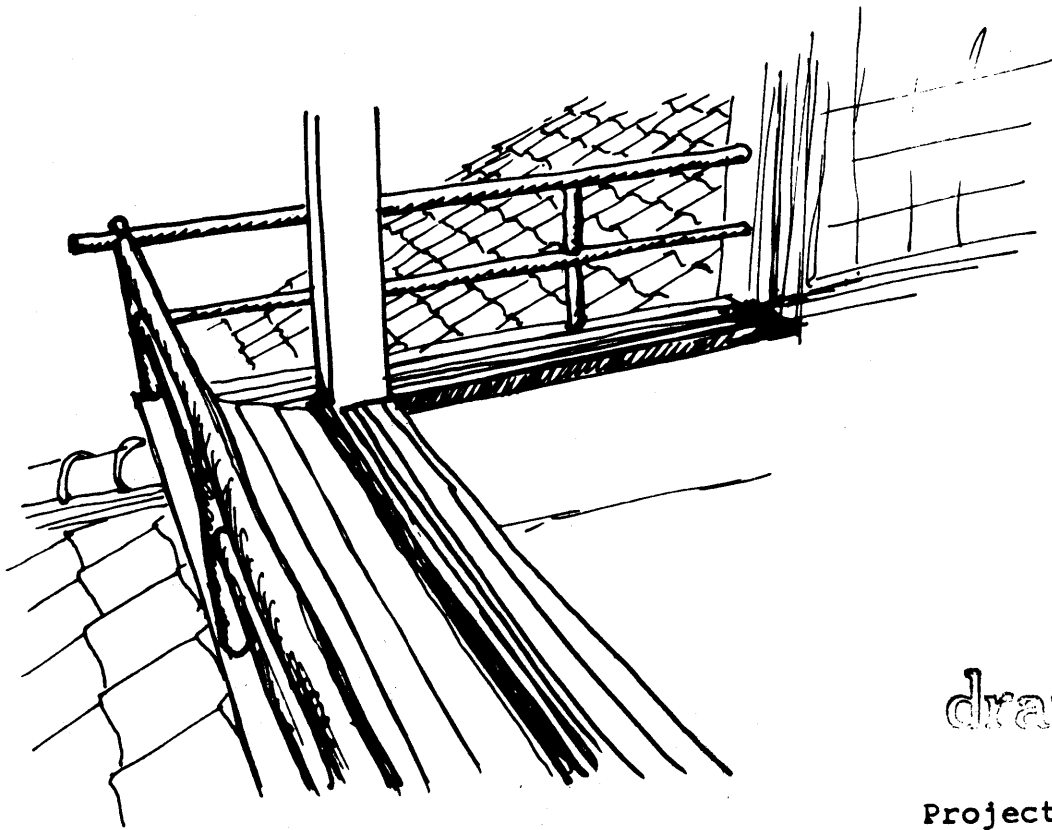
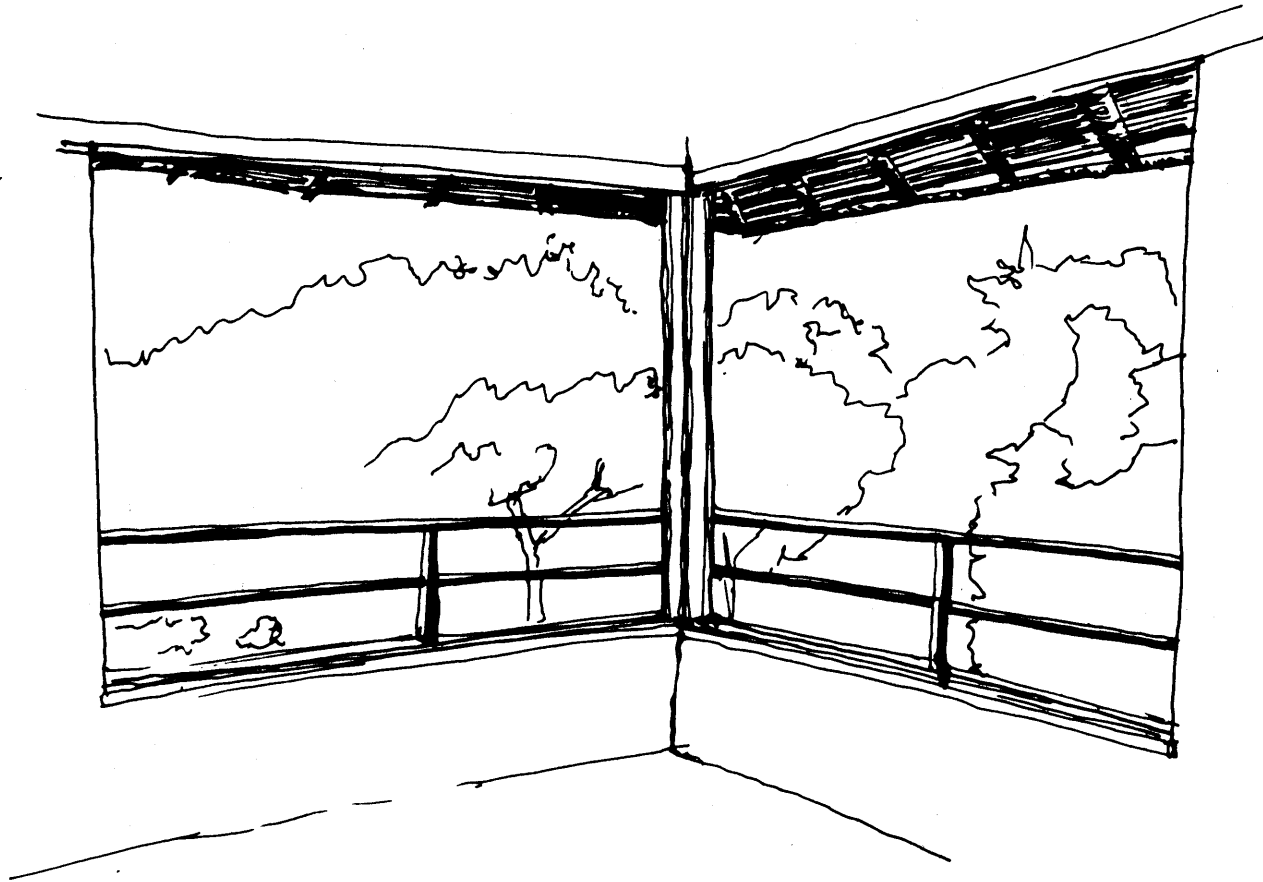

drawing 103

Projecting Window Sill

drawing 98-103

associative form

1. Openings/windows can be built in a minimal dimension wall or be part of a defined spacial zone. In drawing 98, simple openings are placed high on the wall to allow illumination of the floor; clerestory windows allow light to reflect off the ceiling. In drawing 99 a storage cabinet is built under a window defining a use surface/space. Note that with the picture hanging recess a spacial edge is formed along one side of the room. The closets located at right angles to the window also define spacial use zones, but since the doors are usually closed, this wall is associative as planar but variable.
2. In drawings 100 & 102, ventilation openings are made independent of the window openings. This allows control of light and privacy within the space while maintaining ventilation. The low openings also allow direct sunlight on the nearby floor while the shoji screens diffuse the light entering the spaces further from the edge.
3. To control the diffusion of light a double set of windows is utilized in drawing 100. Glass windows allow direct sunlight in and block the weather. When diffused light is desired, the paper screens can be closed.
4. It should be noted that although window and door tracks define spacial zones, these zones are not directly useable for placement of objects or sitting. To extend the window zone and make a use space, projecting sills can be built as in drawing 103. The open railing partially encloses the extended space and allows association with the space beyond.

comments

1. When small dimension building materials are used (3-6"), use zones/spaces associated with windows/openings must be built rather than realized from the dimensions of the materials.
2. To control light quality, privacy, and ventilation, changeable definitions must be provided. However, these definitions need not be combined into one unit.

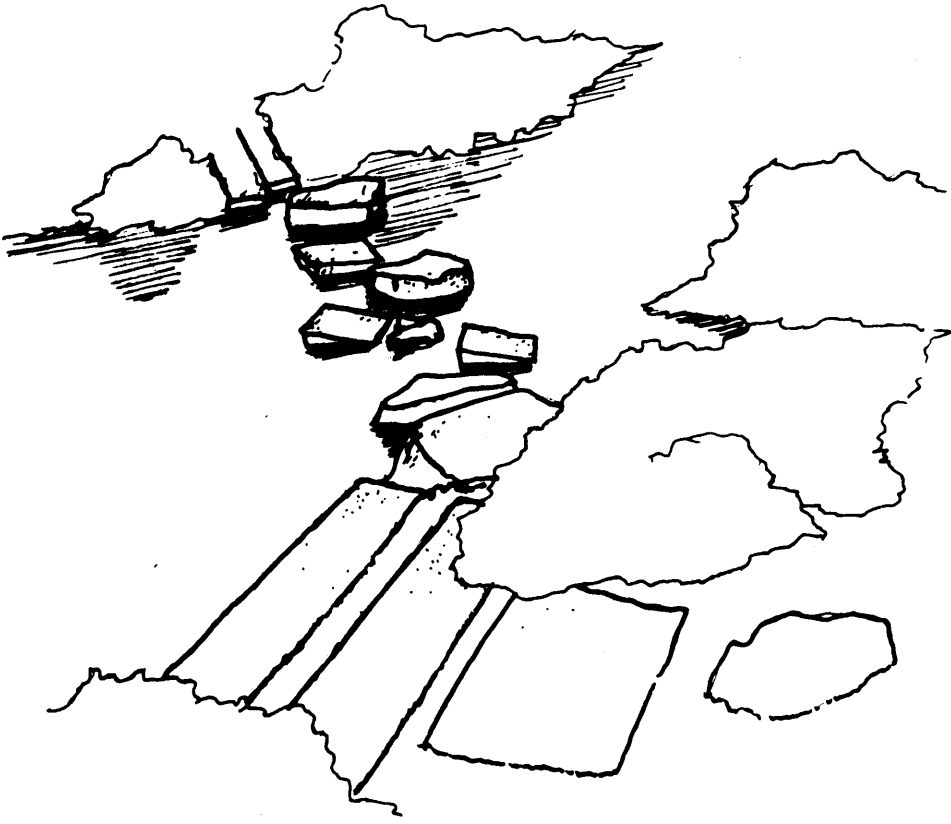

drawing 104

Stepping Stones
Over Water

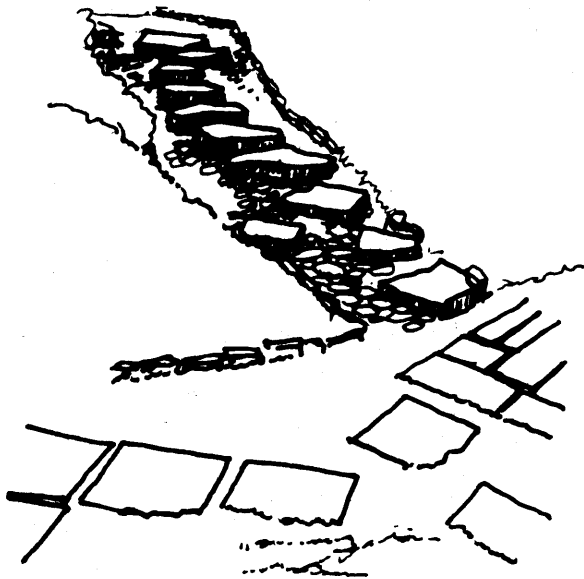

drawing 105

Stepping Stones
Over Pebbles

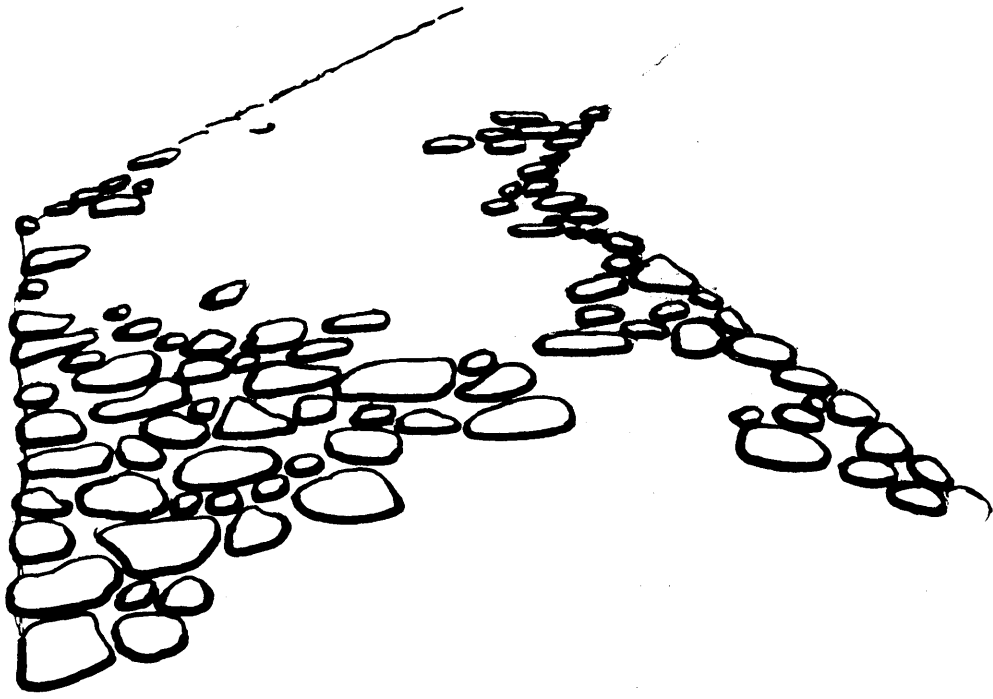

drawing 106

Pathway

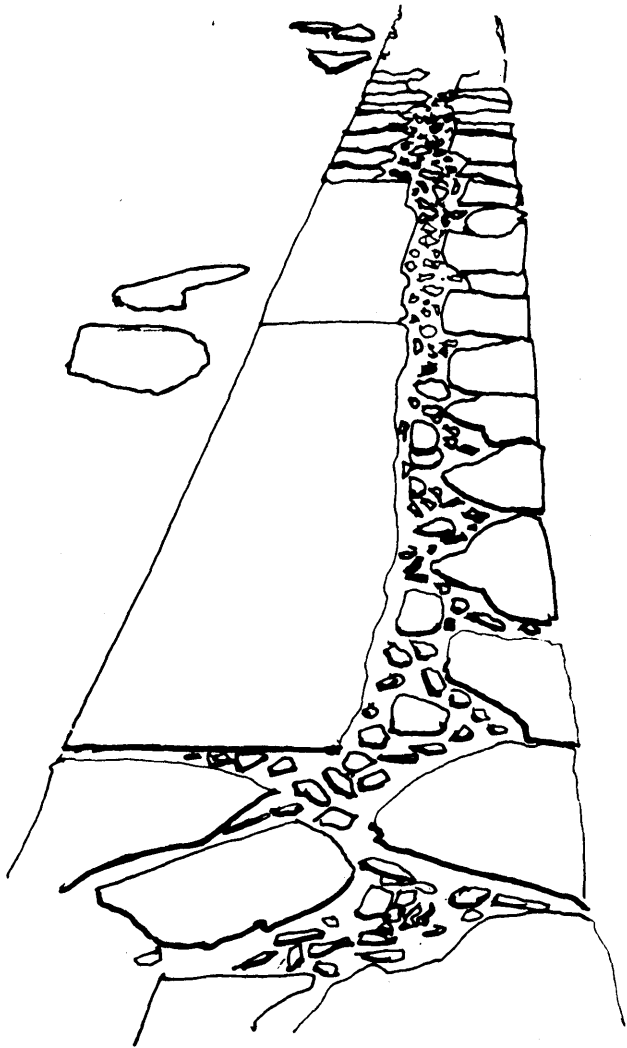

drawing 107

Pathway

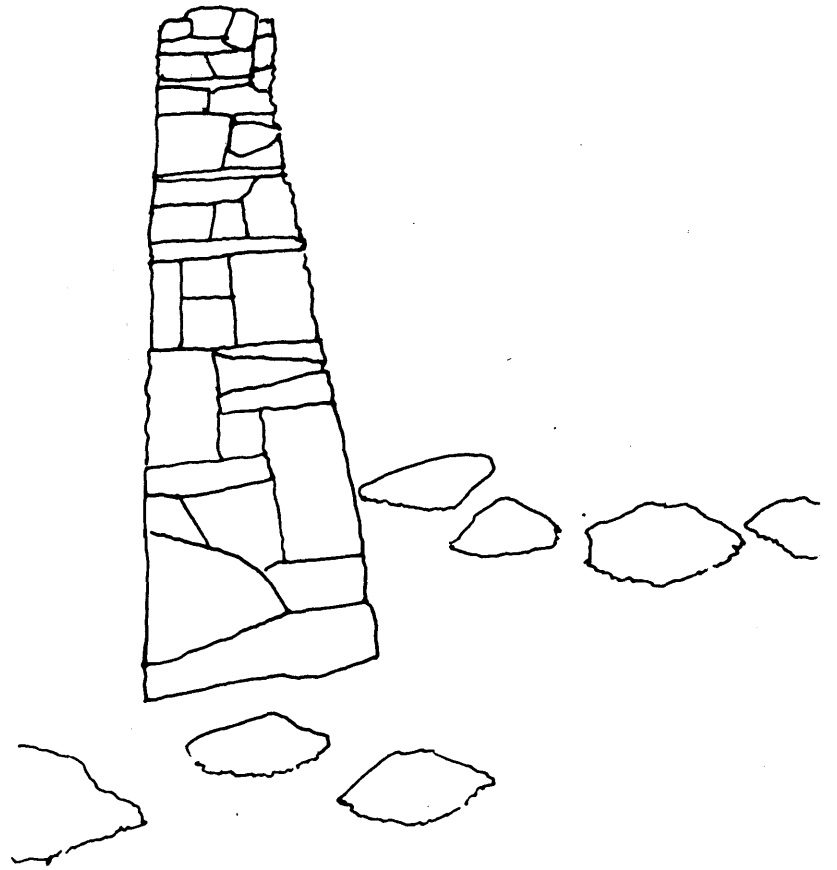

drawing 108

Pathway

drawing 104-108

associative form

1. Japanese pathways are of interest in that movement along the path is additive from one place/space to another. This characteristic is evident in that stones are seldom in a straight line over large distances. In drawing 104, the river bank is approached from an angle allowing persons to stop at the edge of the water and associate with that space before turning to move across the water. Even in crossing the water, stones are provided to allow a person to step aside of the main direction and stop.
2. Pathways in drawings 106 to 108 illustrate paths totally covered with stones. Aside from associations with stones to either side of the path, the stones in the main path indicate special places. In drawing 108, association can be with the larger stones which draw attention alternately right-left right-left. Association may also be with the smaller stones which are closer in dimension to a person's step/stride. The smaller stones are additive in the general direction of the path, but they also direct attention to the side of the path occasionally. In drawing 107, two large stones define the intersection with a path at the left.

Comments

The Japanese sense of spaces in Nature encourages the design of paths which allow/direct movement but also allow association with places/spaces along the route.

projective design

Having drawn a wide range of built forms/associations, it remains to demonstrate the applicability of these forms to present design. For this purpose, a portion of a house plan is reproduced. This plan is then redesigned several times illustrating how different associative forms might change the basic design.

In this effort, no attempt is made to illustrate applicability of all the design issues raised in drawings 1-108. This would be beyond the scope of this thesis. It is believed that illustration of several design issues will be sufficient to demonstrate how the design process can utilize built associative form.

Similar to the compiled drawing explanations, a two part explanation of the projected design is made. The specific design issues as related to associative form are discussed and are referenced by drawing number to the previous drawings and discussions. Comments follow, discussing general aspects of the design.

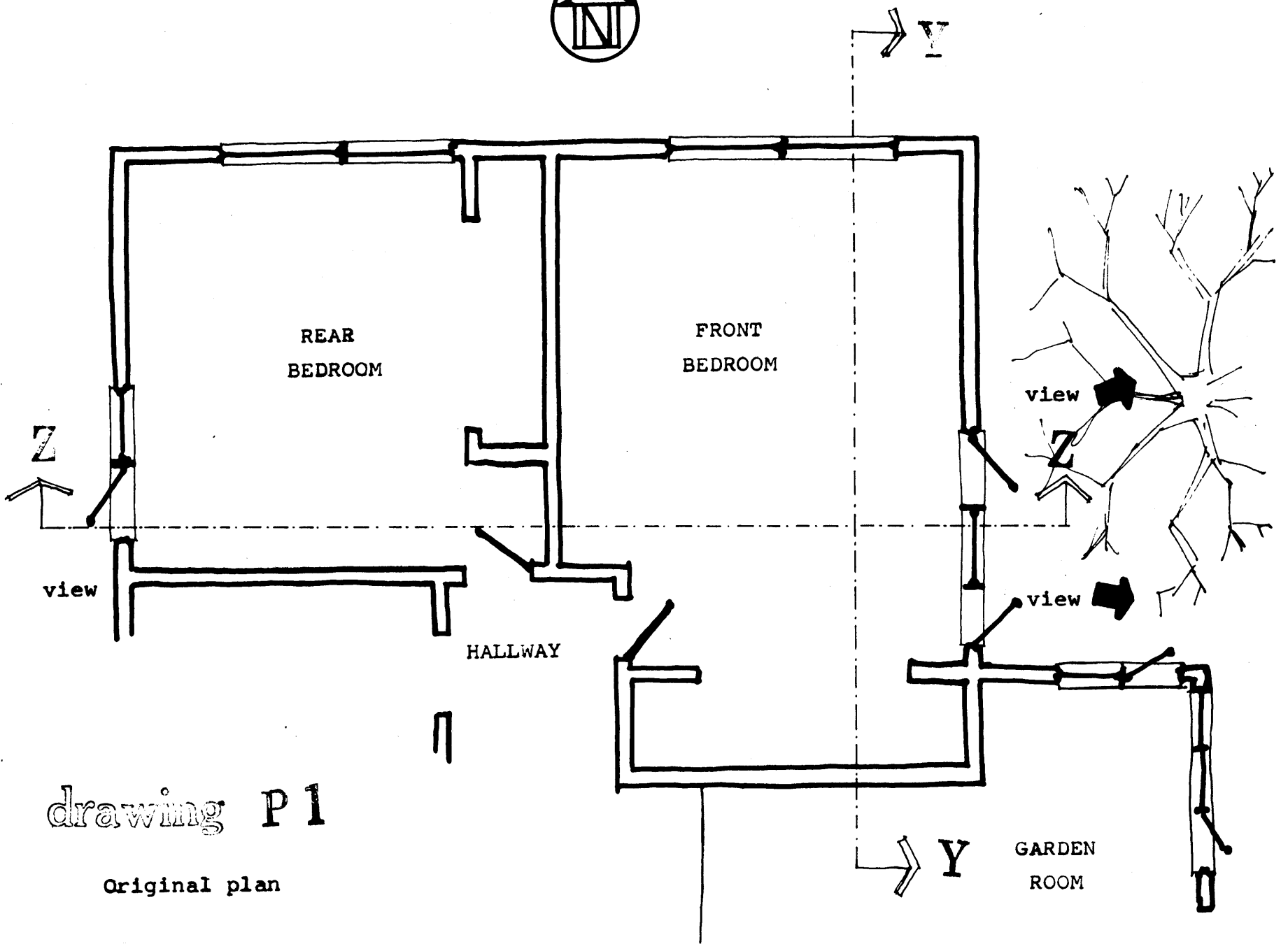

drawing P 1

Original plan

drawing P 2

section Z

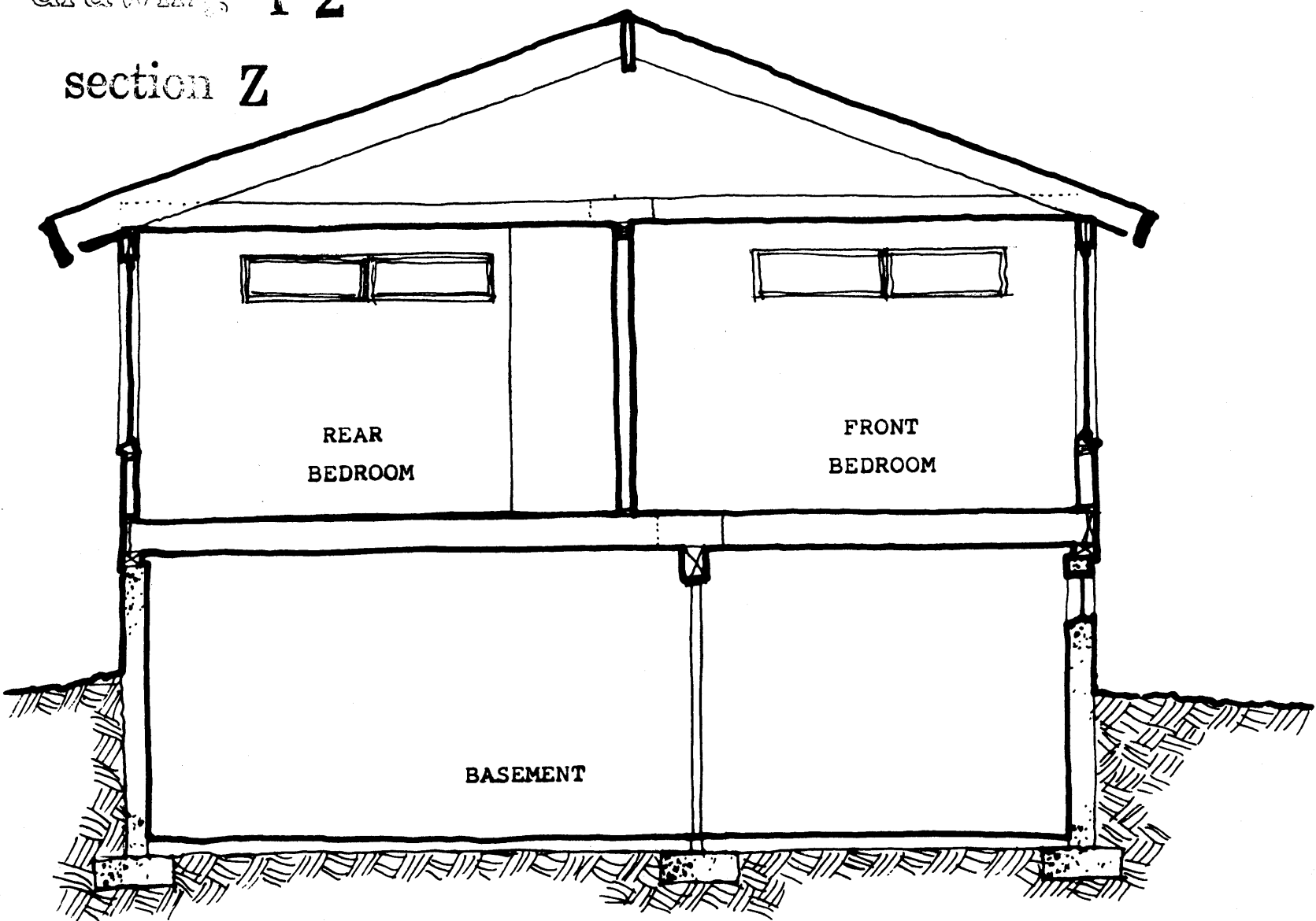

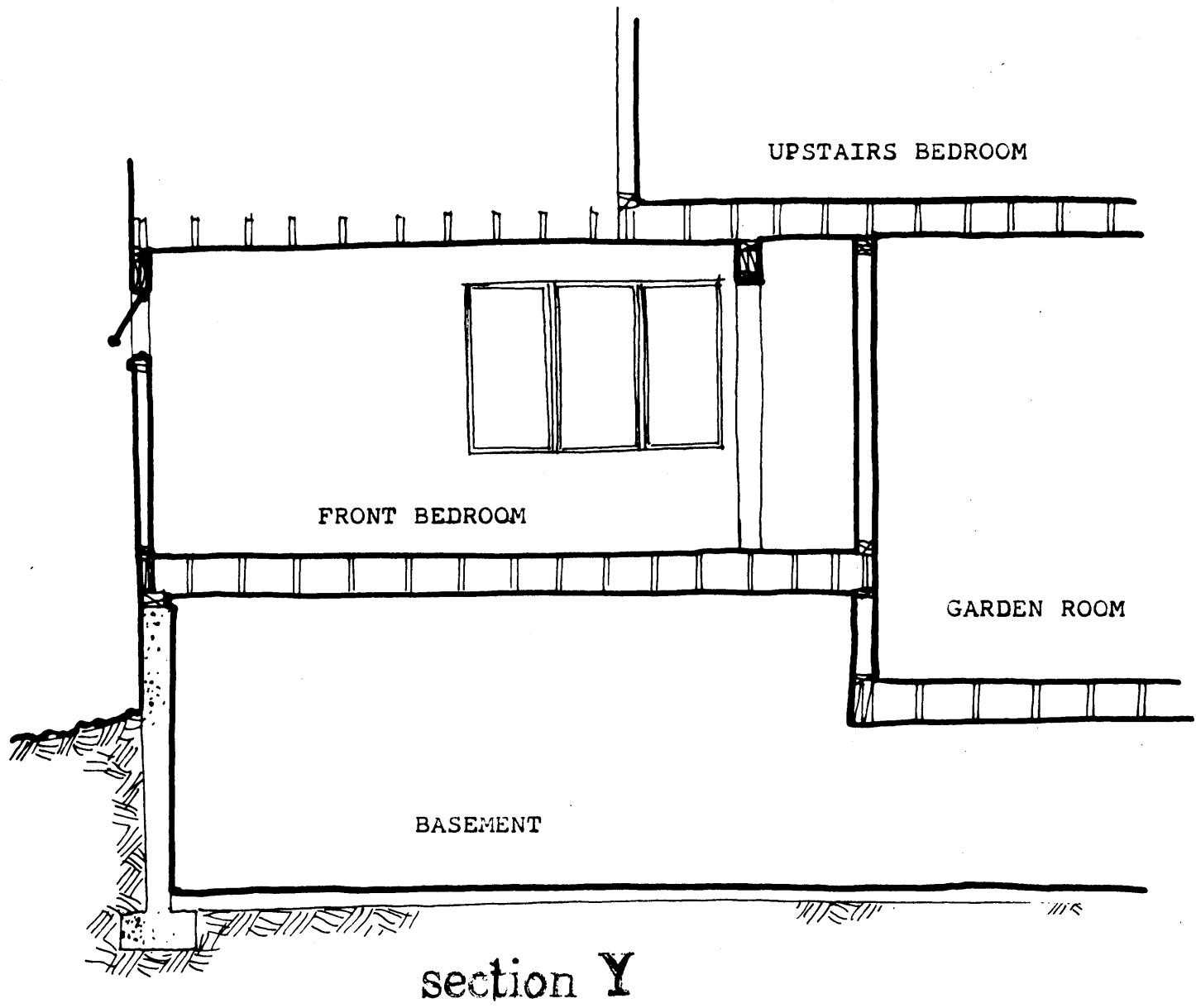

drawing P 3

drawing P 4

Front Bedroom

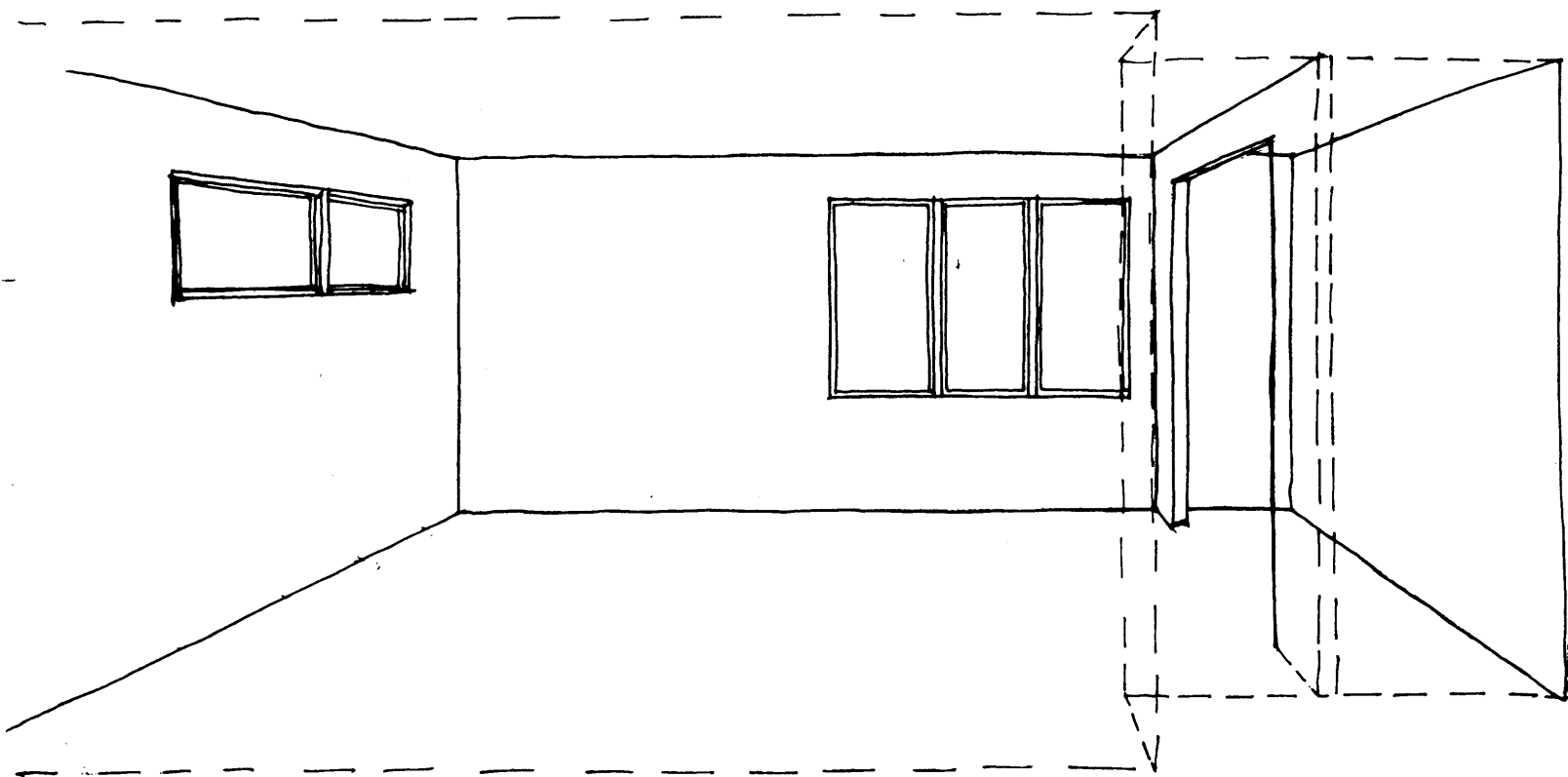

drawing P 1 - P 4

associative form

1. The spaces shown allow minimal association with form. The main room spaces are single rectilinear spaces indicating single use/place/association.
2. The basement space is totally undefined except for uniform walls, ceiling, and floor.
3. Minimal entrance spaces are provided inside each room. In the rear bedroom three walls define/enclose an entrance zone. In the front bedroom, two walls define a space only slightly offset from the main space.
4. The exterior spaces near the house are undefined.

Comments

Although many design changes will subsequently be made to the basic design, the relationship to the site of these spaces will remain a design issue. To the east is a large pine tree and a view of woods and marshlands. To the north are other houses 100 yards away. To the west is a view of the public road and woods. To the south is the remaining spaces of the house which will be considered unchangeable in location and general distribution of activities. For the design changes, only the front and rear bedrooms will be considered.

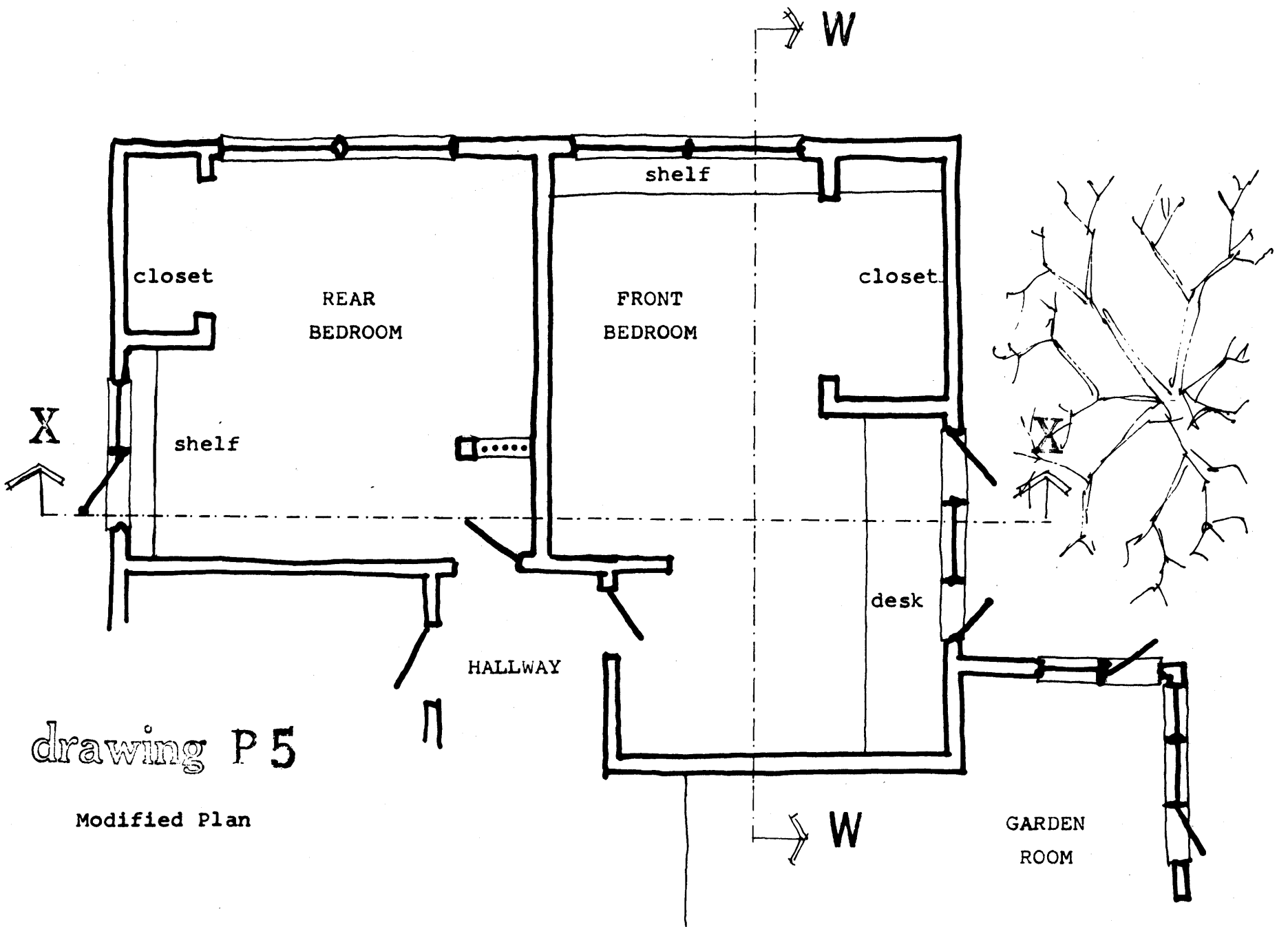

drawing P 5

Modified Plan

drawing P 6

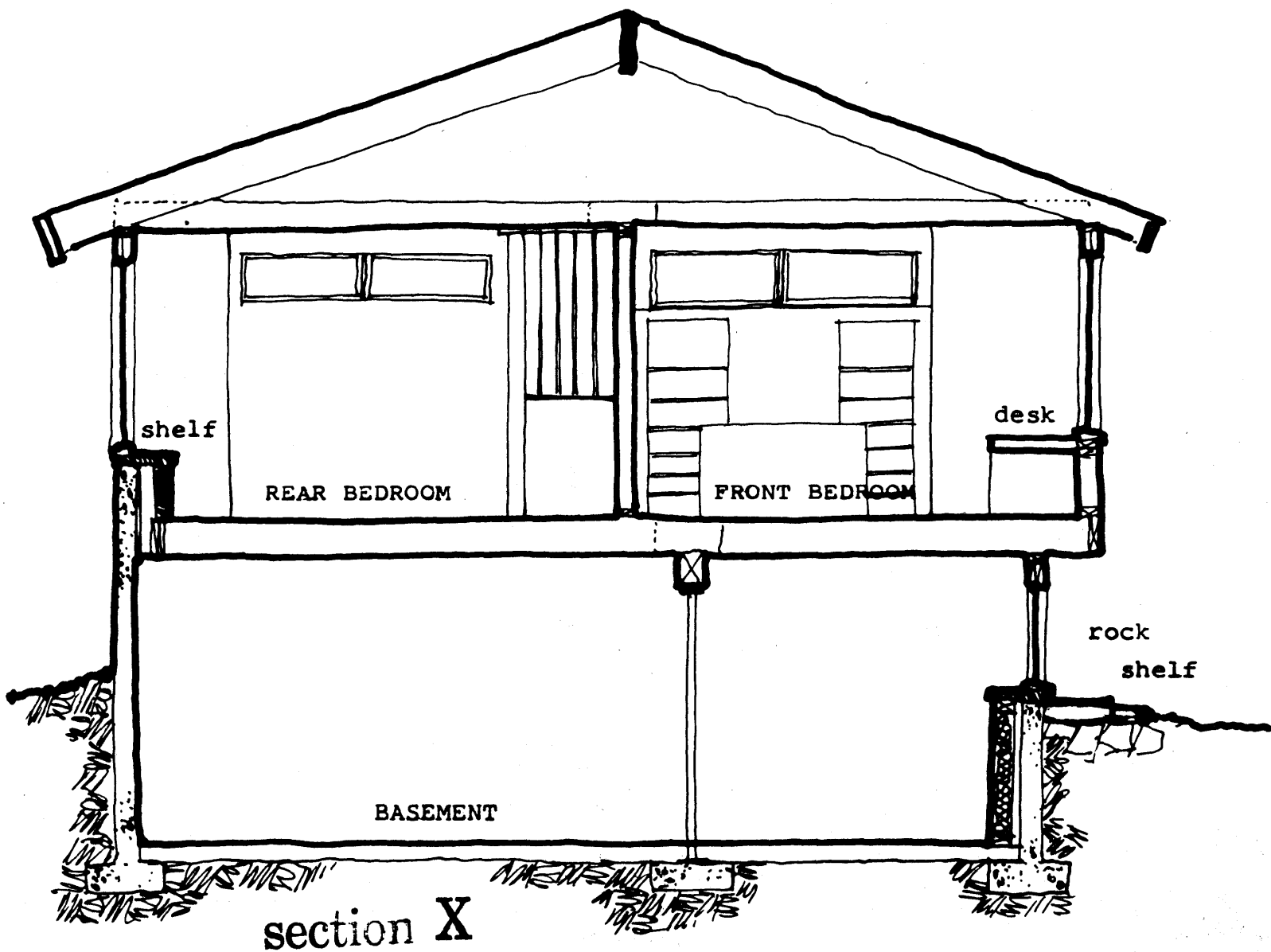

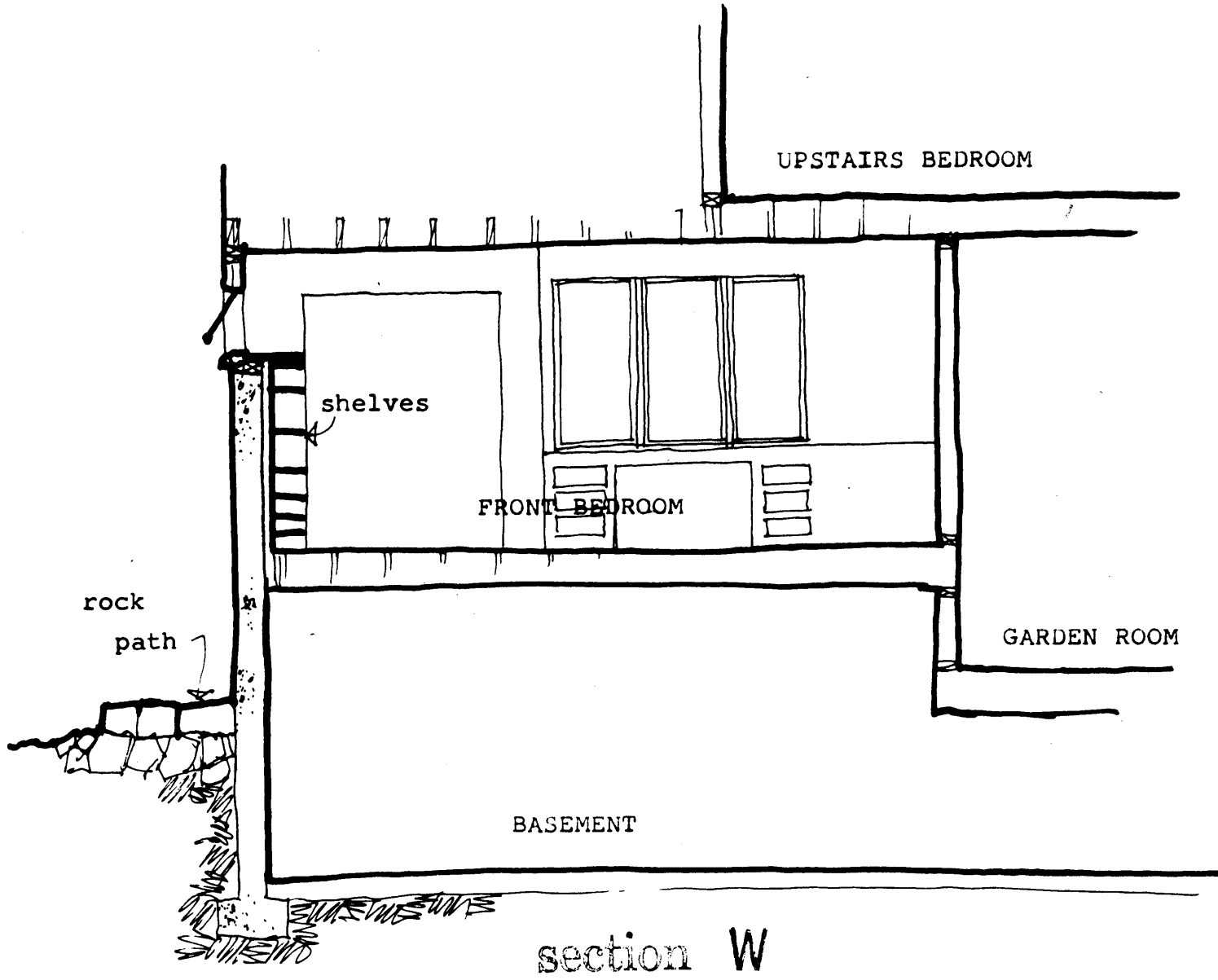

drawing P 7

drawing P 8

Front Bedroom

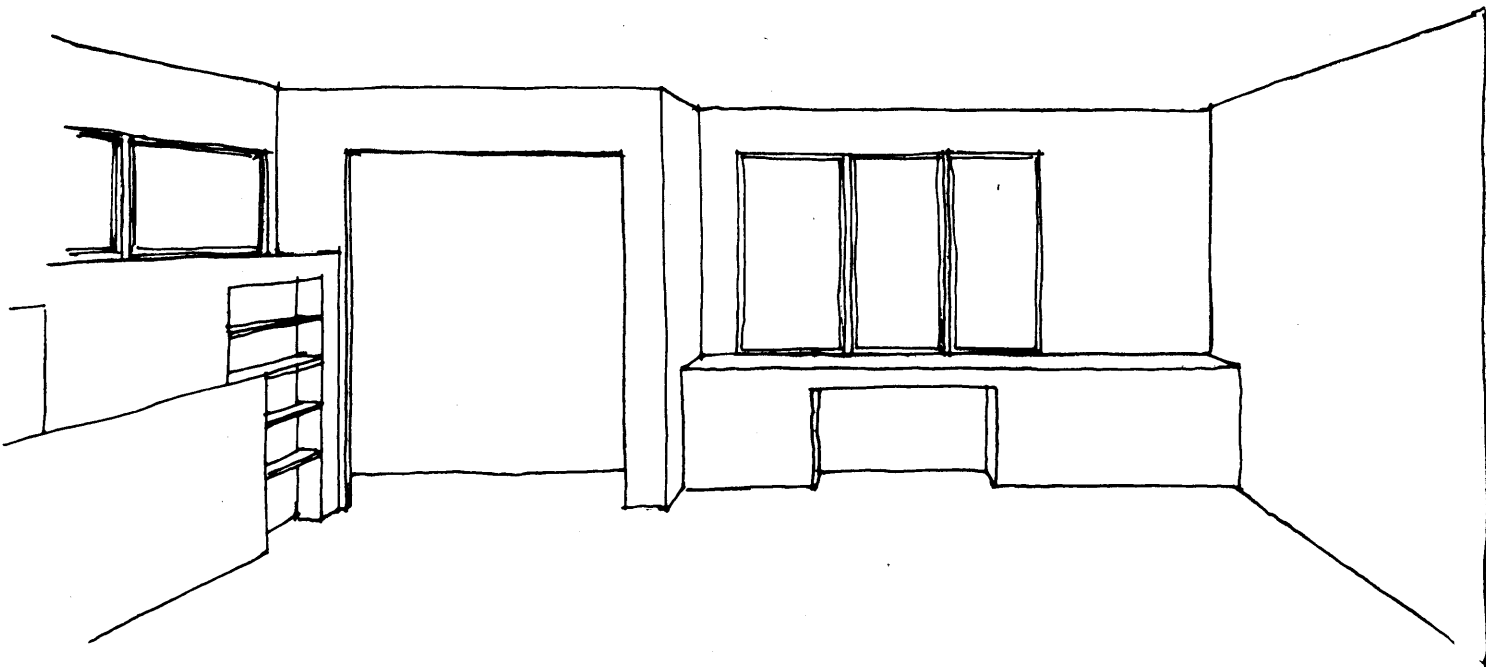

drawing P5 - P8

associative form

1. The most obvious design change made in drawings P5-P8 is building a spacial edge on the exterior walls. This is accomplished by moving the closet spaces to the exterior walls. This arrangement is similar to those found in plans for Japanese houses, drawings 78-85.
2. The use surfaces built in front of the windows allow strong association with spaces outside. The surfaces/spaces are directly adjacent to the windows and associate with both interior and exterior spaces. Association/use of these surfaces/spaces is, therefore, associative with external spaces. Note this affect at various scales in drawings 9, 69 & 72.
3. Creation of spacial zones for the windows has the affect of making the room space several closely associated spaces. Definition of the room space by associated spaces increases the numbers/types of activities that can occur in the spaces. Find similar spacial definition in drawings 65 & 66.
4. Note that the entrance to the rear bedroom in drawing P5 is defined by two walls and a partial wall. A person in the entrance zone/space can view the space as he enters. Conversely, persons in the space are afforded some privacy from the hall space. Refer to drawings 71, 73 & 74.
5. On the north wall, building a use zone in front of the windows allowed definition of storage shelves and spaces, serving alternately as a headboard if a bed is placed against it.
6. The redesign of the basement window under the front bedroom allows use of the window zone internally and externally. The stone steps and cantilevered floor form a small protected place for storage outside.

comments

The changes proposed could be made for little extra cost. The added use surfaces and foundation changes obviously require some additional cost. The changes of the closet locations which introduce major spacial changes are made at no added cost.

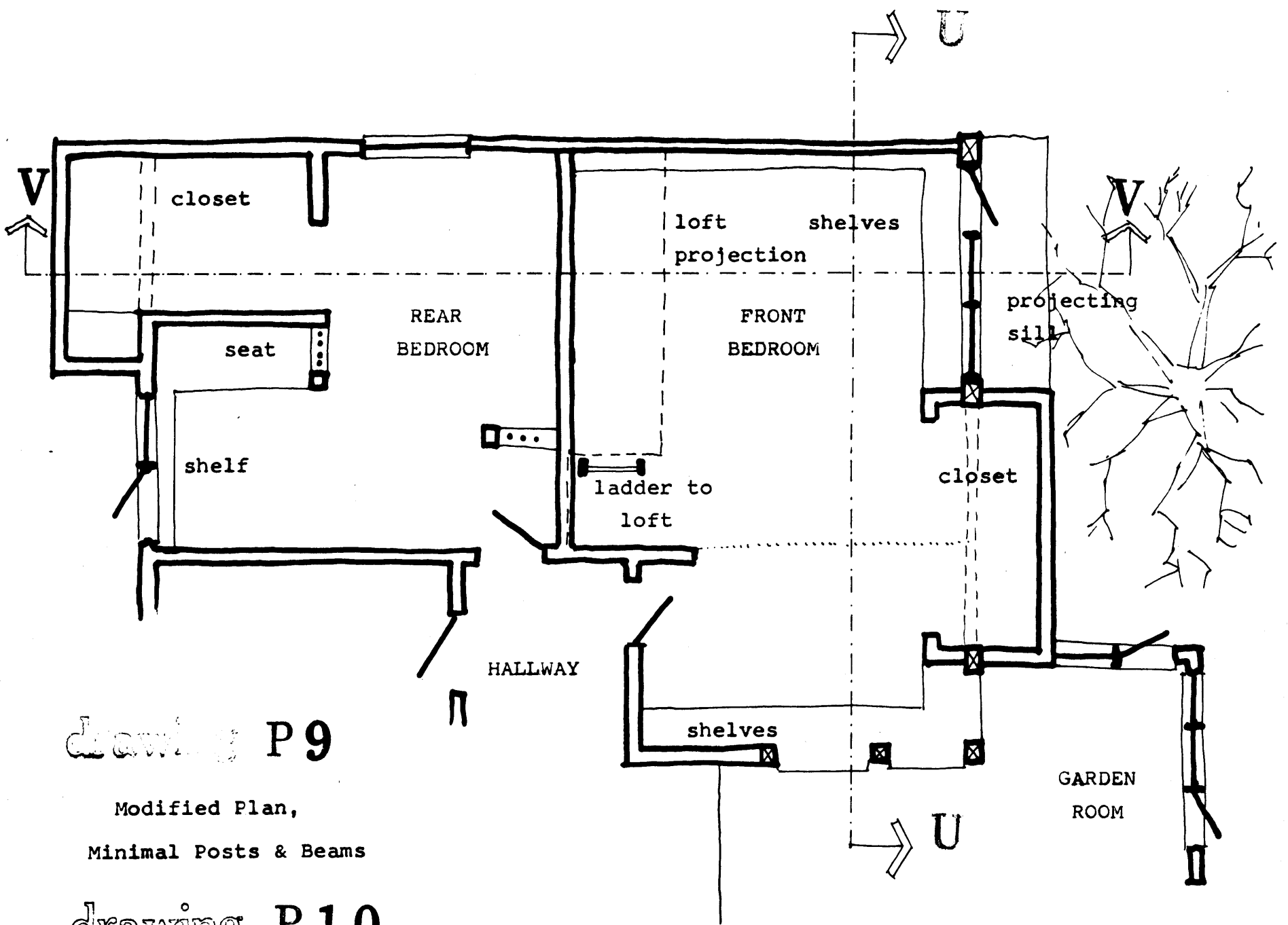

drawing P9

Modified Plan,
Minimal Posts & Beams

drawing P10

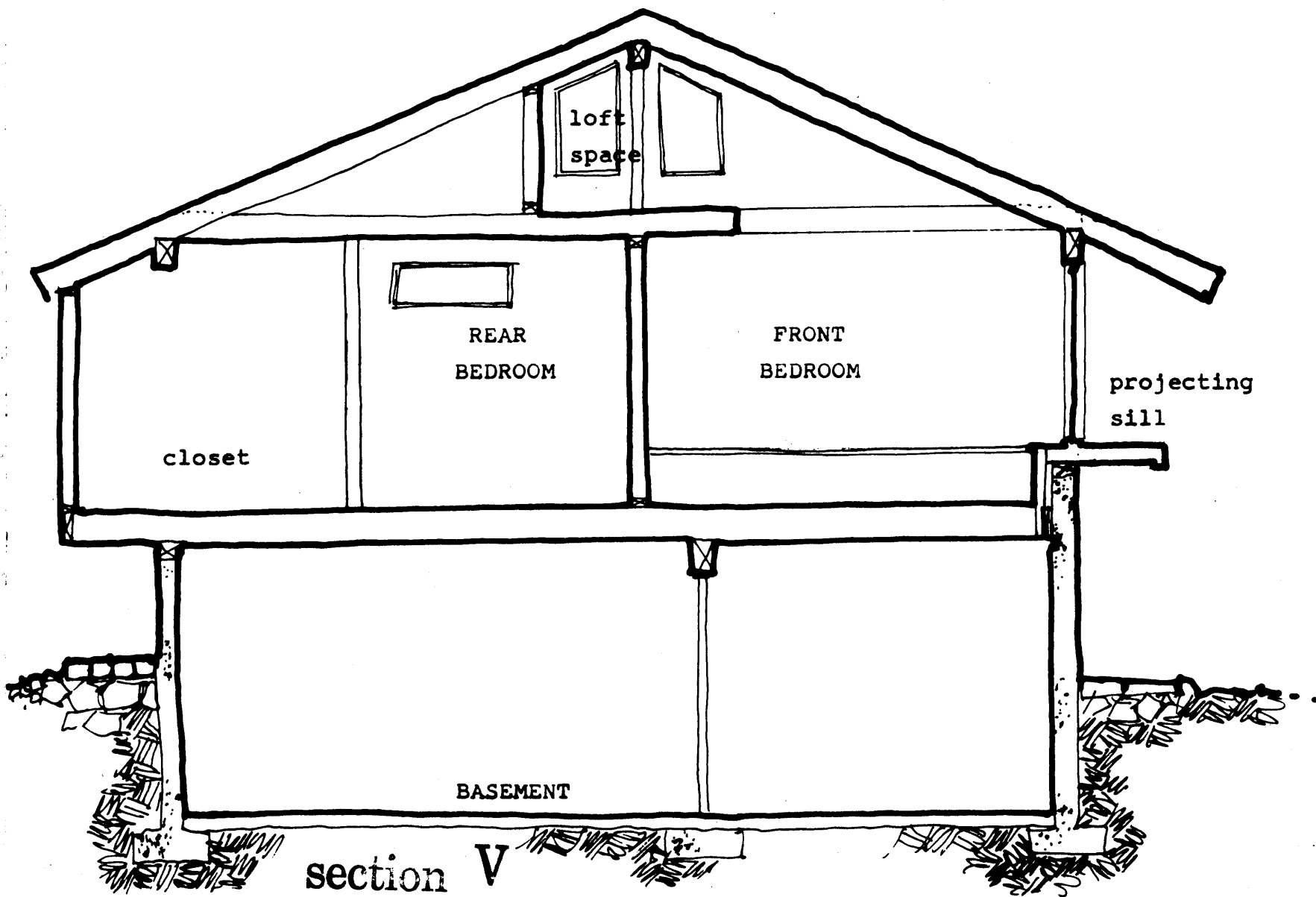

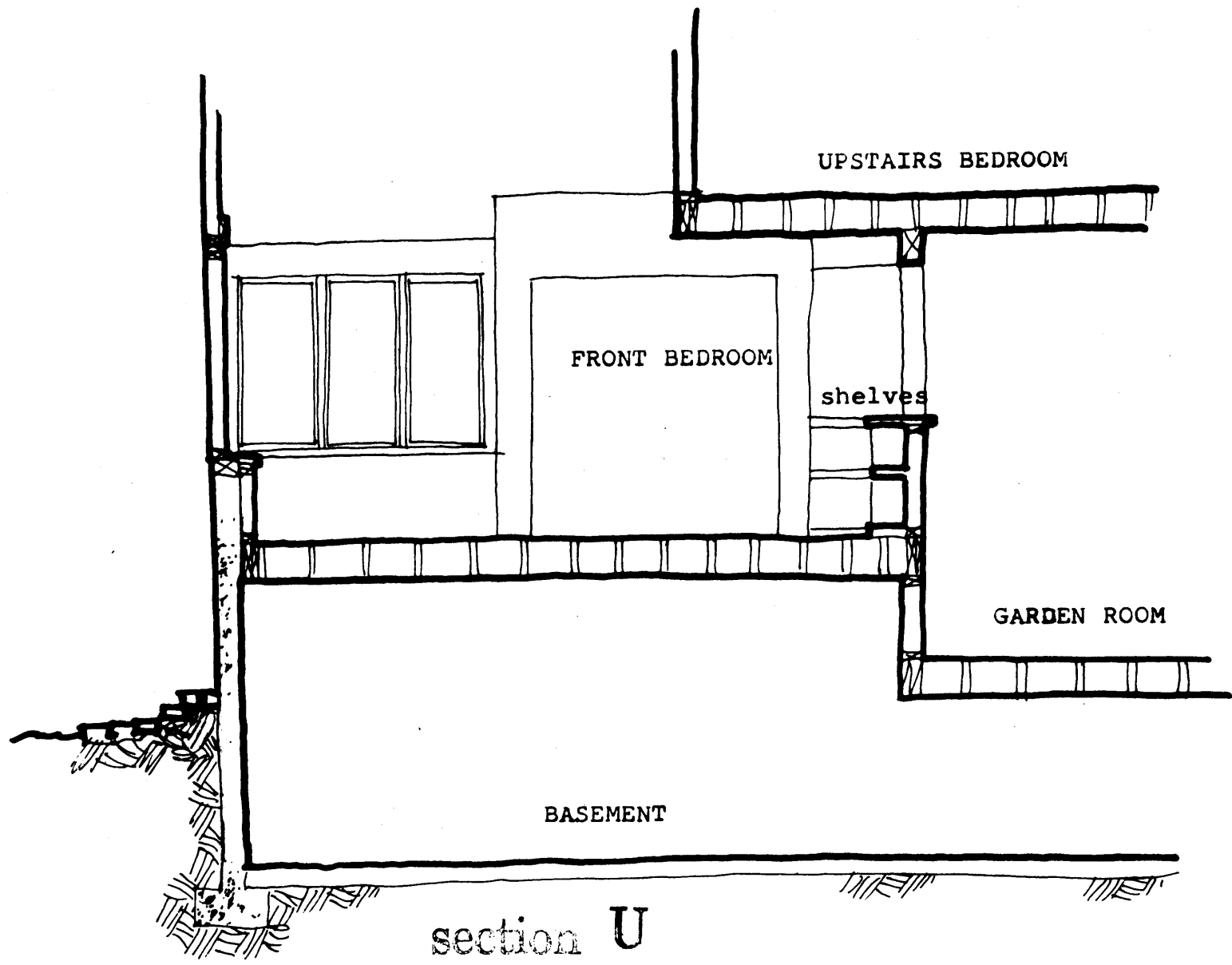

drawing P 1 1

drawing P9 - P11

associative form

1. The changes in the design in drawings P9-P11 indicate the possibilities of adding a post and beam system to standard platform framing techniques. It is possible to replace bearing walls with posts and beams to allow association between separate spaces. The roof can be supported by beams allowing vertical association. Support of the roof edge over the foundation wall allows greater floor cantilever since only the floor and wall loads need be supported by the cantilever. For similar mix of systems refer to drawings 53-56, 57-60.
2. In section U, the front bedroom spaces are now directly associated with the garden room space through an opening in the wall. A use zone defining the opening increases the separation of the spaces while allowing visual access. Similar associations are shown in drawings 34, 36, 37, 43, 71, 72, 74.
3. In the rear bedroom in drawing P9, the window space has a built-in seat next to the window allowing close association with the exterior space. In this example, the window space/zone has not yet moved beyond the main line of the exterior wall. A simple cantilever could be used to extend the window space beyond the wall as in drawing 68. The design shown is similar to drawing 66.
4. The projecting window sill in section V defines a spacial zone in the exterior wall. Association from the inside is first with the external sill and then the external space beyond. Refer to drawings 80, 85, & 103.
5. Note that under the projecting sill is a protected space large enough to stand or sit. This space, partially defined, associates with the exterior space near the wall. It becomes associative since it can be used. Refer to drawings 93-97 for further discussion.
6. The loft space provides a semiprivate space within the front bedroom. Being above the main space, the main space becomes less private.

comments

Used in moderation, posts and beams provide an added degree of design flexibility at a small/moderate cost increase. The added costs are concentrated mainly in the finish costs, i.e., plaster, wood trim, shelves, etc.

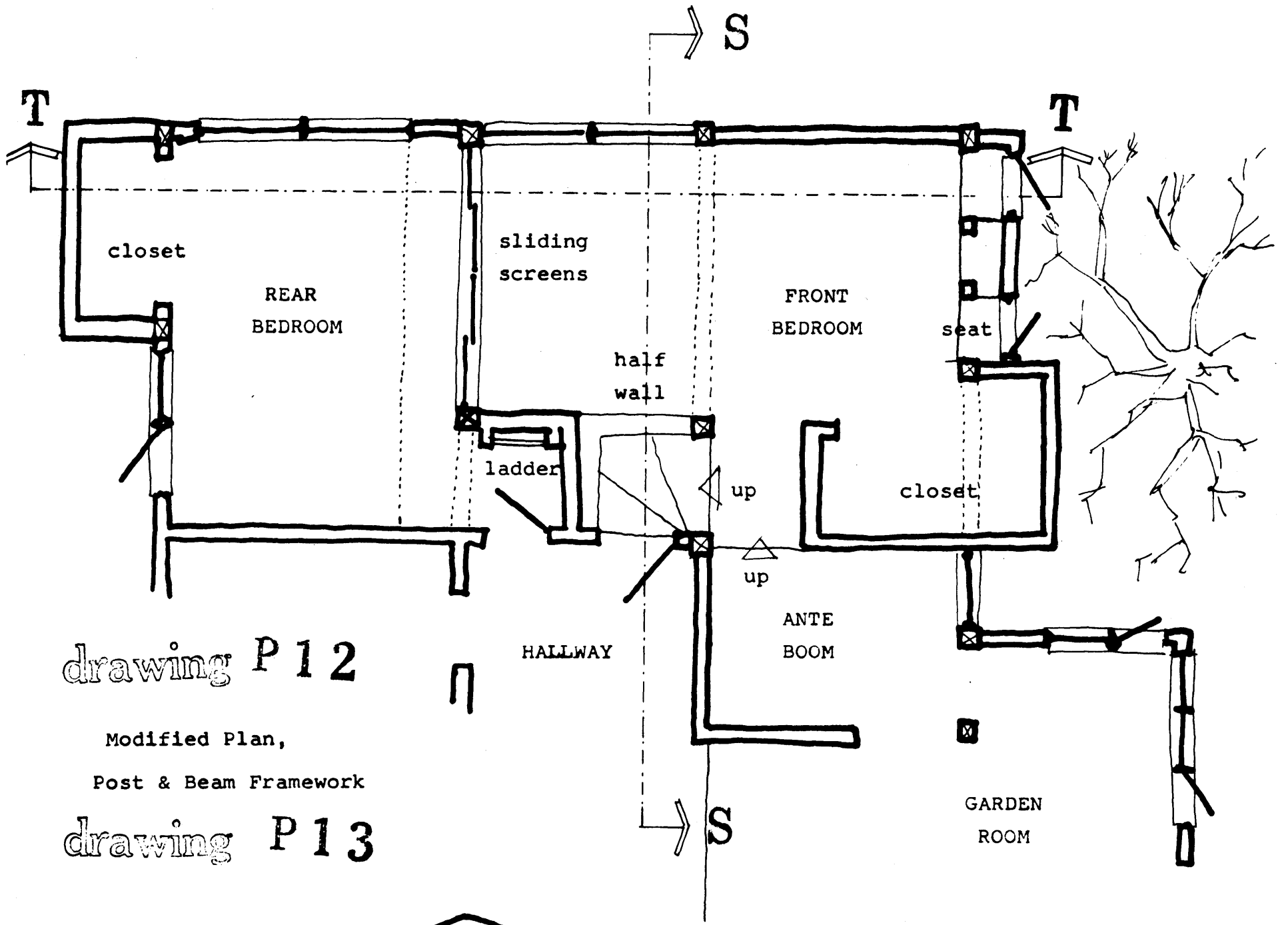

drawing P 12

Modified Plan,
Post & Beam Framework

drawing P 13

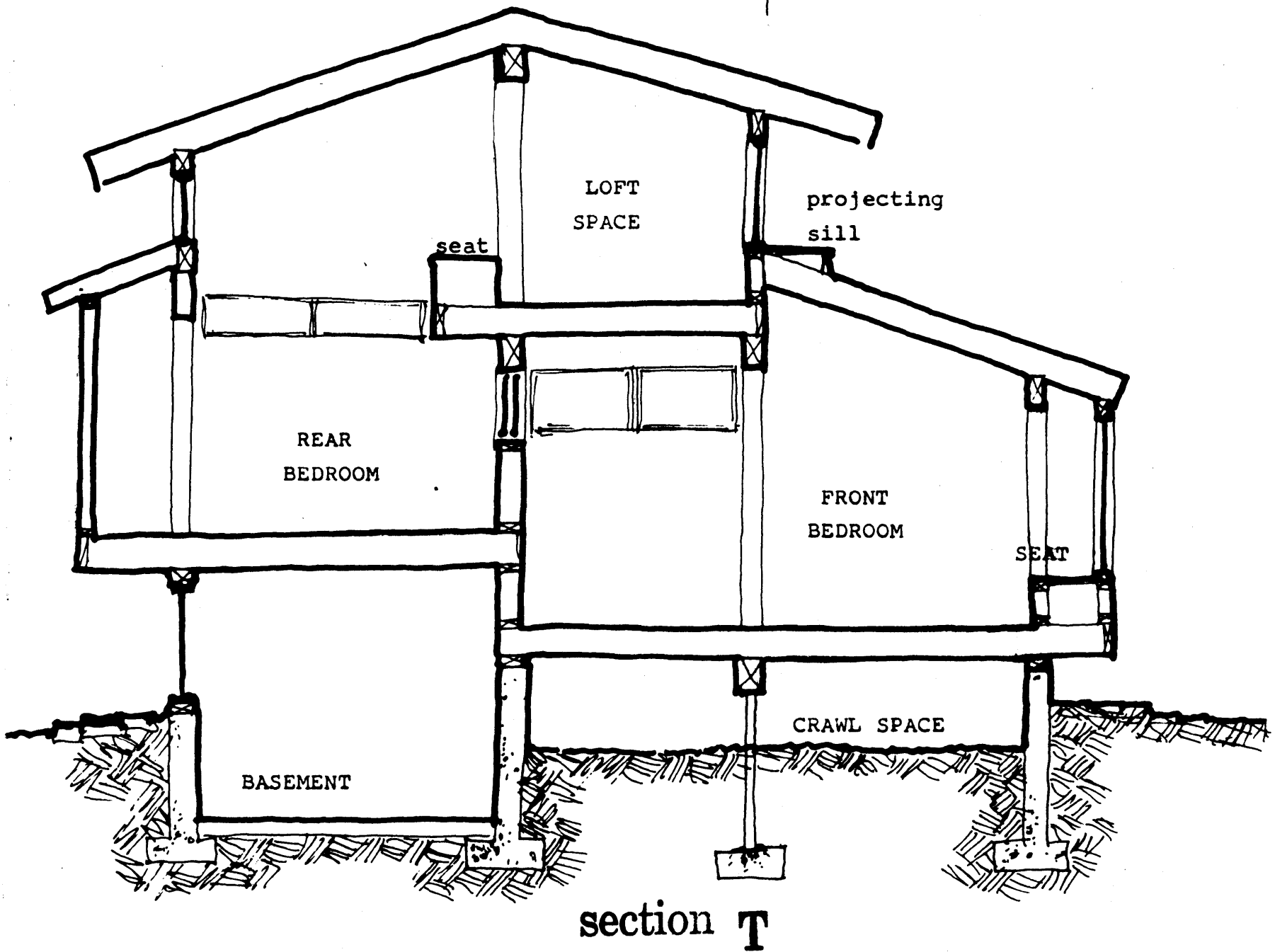

section T

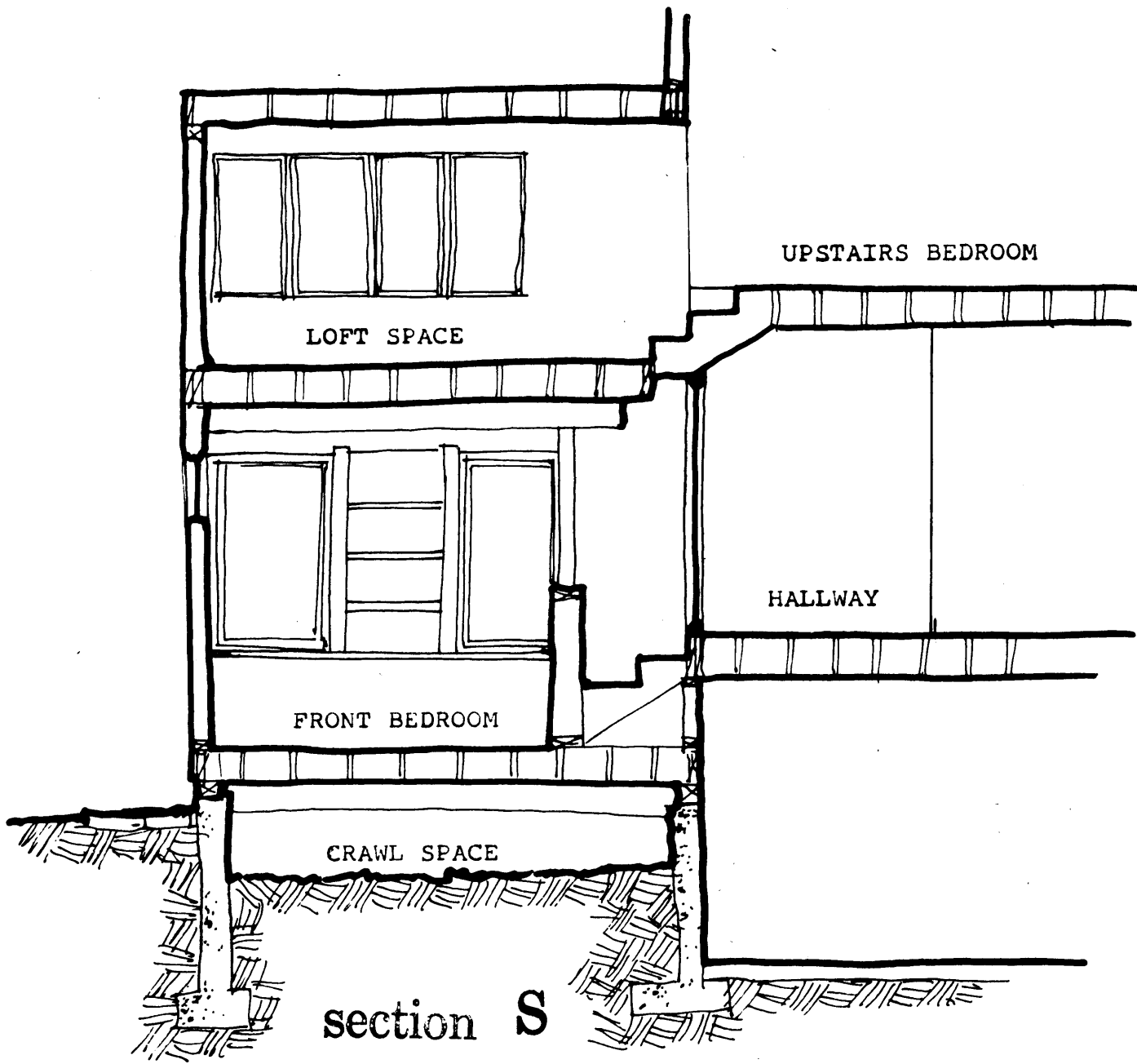

drawing P 14

drawing P12 P14

associative form

1. Carried to a further degree of complexity, posts and beams can be utilized to define a large framework within which spaces are further defined by structural panels/screens/windows. Drawings P12-P14 illustrate an example of such a design. Discussion of these issues is in reference to drawings 51,52, 53-56.
2. In drawing P12, rear and front bedrooms are associated through the sliding screens under the loft. The front bedroom is lowered to 6 inches above the garden room floor and is associated with the garden room space through various openings and the ante room space. Minimal access between spaces provides sufficient privacy for the bedroom.
3. The loft space serves as a connecting/dividing space between the upstairs bedroom and the rear bedroom, sections T & S. Although access is difficult, up the ladder, etc., the loft connection to the upstairs bedroom establishes an association between the first and second story levels.
4. The partial wall serving as a railing for the stairs leading from the hallway to the bedroom allows association with the bedroom space as a person descends the stairs. See drawings 45-47.
5. The window seat in the front bedroom defines a spacial zone along the edge of the wall. Large enough for sitting, the depth of the zone allows multiple use of the space. Similar spaces are illustrated in drawings 6 & 21.

Comments

The design illustrated represents a major cost increase. For this increase in cost, however, the floor area is increased and a rich set of associations between spaces has been established.

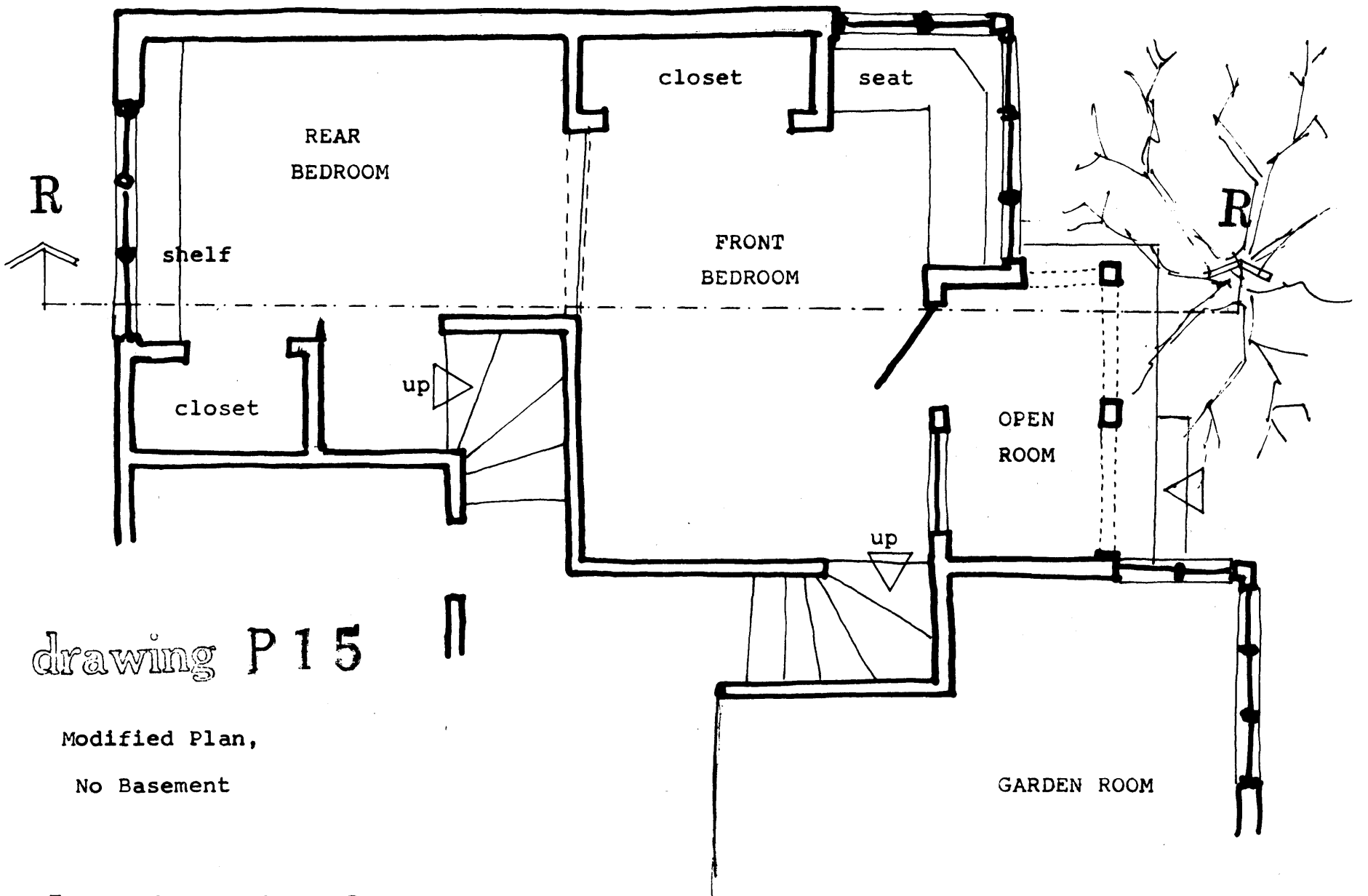

drawing P15

Modified Plan,
No Basement

drawing P16

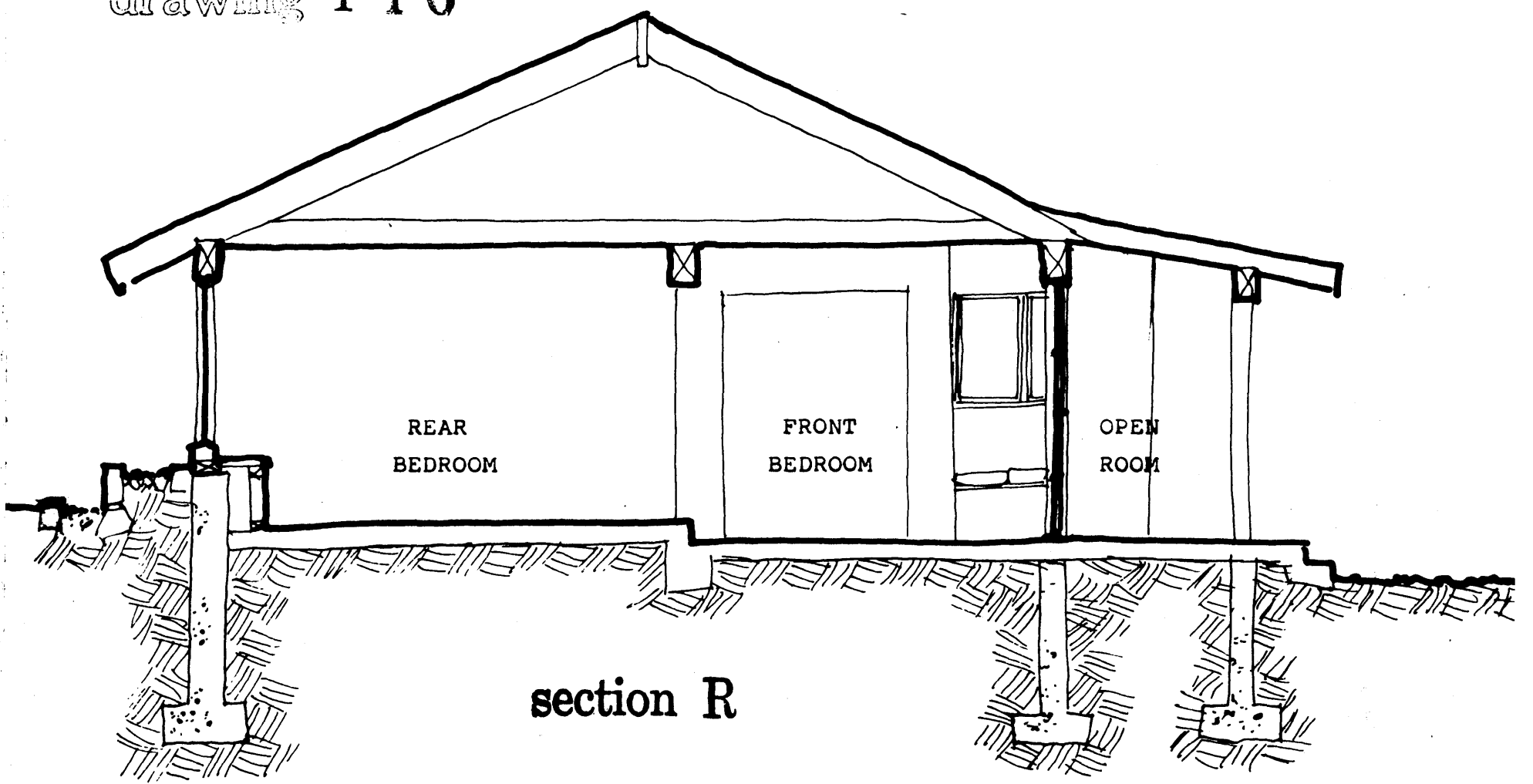

drawing P15 - P16

associative form

1. Drawings P15-P16 represent a major departure from the original design. In this design the basement has been eliminated. Further, the two bedroom spaces have been connected via a wide opening. In this case, a 6 inch level change and ceiling beam are used to define the change between the two spaces. As connected spaces, the rooms are similar in design to connected Japanese house spaces. Refer to drawings 43, 75-76, & 78-85.
2. The covered porch is an open room forming a exterior spacial zone in the line of the wall. Bringing the outside space inward provides a close association with the nearby tree. The exterior walls partially enclose the space which can be seen to be a partial enclosure of the space in the vicinity of the tree. Refer to drawing 44.
3. The window seat provides a protected sitting area within the larger space. The high windows over the seat are more useful for admitting light rather than encouraging an association with exterior space. Refer to drawings 20 & 68

comments

Built as a slab on grade or a wooden floor over a crawl space, this design does not represent a major cost increase over the initial design. In fact some saving might be in order. The design does indicate the potential of relating interior spaces/ levels to exterior ground spaces.

references:

1. The Japanese House and Garden,
Tetsuro Yoshida,
Praeger Publishers, N.Y. 1969
2. La Casa Colonial Venezolana,
Graziano Gasparini,
Centro Estudiantes de Arquitectura Universidad Central
de Venezuela, Caracas 1962
3. Schlesische Holzbauten,
Ludwig Loewe,
Werner-Verlag, Dusseldorf 1963
4. Design in Greece, Annual Review
Architecture in Greece Press,
Athens, Greece 1969
5. The Mexican House Old and New
Verna and Warren Shipway,
Architectural Book Publishing Co., Inc. N.Y. 1960
6. Landhaus Und Garten,
Hermann Muthesius F. Bruckmann,
A. G., Munchen 1910

drawing references:

Drawing No.

1. Ref. 4 Pg. 91
 2. Ref. 4 Pg. 91
 3. Ref. 4 Pg. 94
 4. Ref. 4 Pg. 96
 7. Ref. 4 Pg. 101
 8. Ref. 4 Pg. 105
 12. Ref. 4 Pg. 98
 13. Ref. 4 Pg. 98
 15. Ref. 4 Pg. 106
 16. Ref. 4 Pg. 111
 17. Ref. 4 Pg. 109
 18. Ref. 4 Pg. 110
 19. Ref. 4 Pg. 103
 22. Ref. 4 Pg. 113
 24. Ref. 5 Pg. 6
 25. Ref. 5 Pg. 7
 26. Ref. 5 Pg. 3
 27. Ref. 5 Pg. 47
 33. Ref. 5 Pg. 112
 34. Ref. 5 Pg. 113
 35. Ref. 2 Pg. 130
 36. Ref. 2 Pg. 126
 37. Ref. 2 Pg. 125
 38. Ref. 2 Pg. 136
 39. Ref. 2 Pg. 141
 40. Ref. 2 Pg. 152
 41. Ref. 5 Pg. 113
 42. Ref. 5 Pg. 111
 43. Ref. 5 Pg. 111
 44. Ref. 5 Pg. 115
 45. Ref. 5 Pg. 143
 46. Ref. 5 Pg. 143
 47. Ref. 5 Pg. 145
 48. Ref. 2 Pg. 135
 49. Ref. 2 Pg. 136
 50. Ref. 3 Pg. 110
 51. Ref. 3 Pg. 37
 52. Ref. 3 Pg. 63

Drawing No.

53. Ref. 3 Pg. 39
 54. Ref. 3 Pg. 55
 55. Ref. 3 Pg. 121
 56. Ref. 3 Pg. 150
 57. Ref. 3 Pg. 26
 58. Ref. 3 Pg. 105
 59. Ref. 3 Pg. 106
 60. Ref. 3 Pg. 91
 61. Ref. 3 Pg. 143
 62. Ref. 3 Pg. 131
 63. Ref. 3 Pg. 66
 64. Ref. 3 Pg. 66
 65. Ref. 6 Pg. 71
 66. Ref. 6 Pg. 69
 67. Ref. 6 Pg. 93
 68. Ref. 6 Pg. 87
 69. Ref. 6 Pg. 88
 70. Ref. 6 Pg. 91
 71. Ref. 6 Pg. 78
 72. Ref. 6 Pg. 73
 73. Ref. 6 Pg. 205
 74. Ref. 6 Pg. 202
 75. Ref. 6 Pg. 83
 76. Ref. 6 Pg. 84
 77. Ref. 6 Pg. 67
 79.-85. Ref. 1
 86. Ref. 1 Pg. 131
 87. Ref. 1 Pg. 143
 88. Ref. 1 Pg. 147
 89. Ref. 1 Pg. 160
 90. Ref. 1 Pg. 117
 91. Ref. 1 Pg. 110
 92. Ref. 1 Pg. 64
 93. Ref. 1 Pg. 53
 94. Ref. 1 Pg. 47
 95. Ref. 1 Pg. 49
 96. Ref. 1 Pg. 49
 97. Ref. 1 Pg. 190

Drawing No.

98. Ref. 1 Pg. 116
 99. Ref. 1 Pg. 89
 100. Ref. 1 Pg. 149
 101. Ref. 1 Pg. 164
 102. Ref. 1 Pg. 165
 103. Ref. 1 Pg. 150
 104. Ref. 1 Pg. 185
 105. Ref. 1 Pg. 182
 106. Ref. 1 Pg. 179
 107. Ref. 1 Pg. 181
 108. Ref. 1 Pg. 180

index

type of building system:

Stone With Heavy Framing

Drawings: 1 - 21

Masonry With Heavy Framing, Post & Beam

Drawings: 22 - 49

Log, Braced Frame, Frame and Boards

Drawings: 50 - 64

Heavy Framing, Light Framing, Masonry

Drawings: 65 - 77

Post & Beam, Light Panels, Screens

Drawings: 78 - 108

type of use / association:

Stair/Level Changes

Drawings: 1, 9, 14, 15, 24-25, 39, 41-44, 45-47, 61-63,
67-68, 72, 71, 73-74, 75-76, 77, 90, 93-97

Doors/Windows/Openings/Entrances

Drawings: 3-6, 7-9, 12-14, 16-20, 21, 22-23, 24-27, 41-44,
55-56, 63-64, 65-66, 68, 69-70, 71, 72, 73-74, 78-85, 86-89,
90-92, 98-103

Balconies/Terraces/Verandas/Exterior Spaces

Drawings: 1, 3-6, 15, 16-20, 22-23, 24-32, 33-34, 35-40,
41-44, 50, 53-56, 57-60, 78-85, 86-89, 93-97

Floors/Ceilings/Walls/Use Surfaces

Drawings: 3-6, 7-9, 10-11, 12-14, 21, 33-34, 39-40, 48-49,
51-52, 53-56, 104-108

Distribution of Major Spaces

Drawings: 1, 15, 22-23, 24-25, 35, 51-52, 59, 78-85

Building Materials/Systems

Drawings: 1, 3-6, 9, 15, 16-20, 22-23, 50, 51-52, 53-56,
57-60, 78-85, 90

Small Use Spaces/Zones

Drawings: 3-6, 7-8, 12-14, 16-20, 21, 23-34, 43, 45,
55-56, 65-66, 72, 78-85, 91, 98-103,

Habitable Spaces/Zones (Interior)

Drawings: 12-14, 16-19, 21, 65-66, 67, 71, 73-74, 75-76,
77, 78-85, 91-92

Habitable Spaces/Zones (Interior/Exterior)

Drawings: 7-9, 20, 24-32, 41-44, 68-76, 78-89, 98-103