



COMMISSION OF THE EUROPEAN COMMUNITIES

Nuclear Science and Technology

**THE COMMUNITY'S RESEARCH AND
DEVELOPMENT PROGRAMME ON
DECOMMISSIONING OF
NUCLEAR INSTALLATIONS (1989-93)**

Annual progress report 1990

EUR 14227 EN

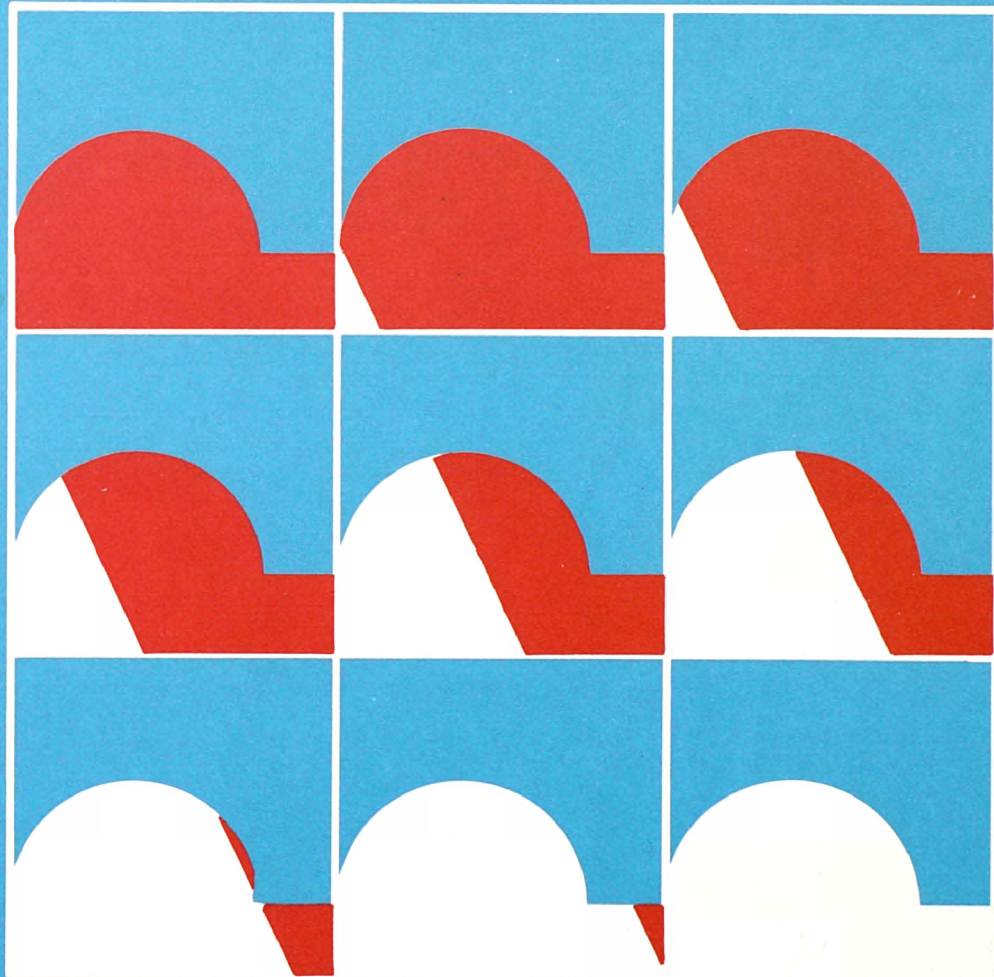

**RESEARCH PROGRAMME
DECOMMISSIONING OF NUCLEAR INSTALLATIONS**

Commission of the European Communities

Nuclear Science and Technology

**THE COMMUNITY'S RESEARCH AND
DEVELOPMENT PROGRAMME ON
DECOMMISSIONING OF
NUCLEAR INSTALLATIONS (1989-93)**

Annual progress report 1990

EUR 14227 EN

Directorate-General
Science, Research and Development

**Published by the
COMMISSION OF THE EUROPEAN COMMUNITIES
Directorate-General
Telecommunications, Information Industries and Innovation
L - 2920 Luxembourg**

LEGAL NOTICE

Neither the Commission of the European Communities nor any person acting on behalf of the Commission is responsible for the use which might be made of the following information

Catalogue number: CD-NA-14227-EN-C

© ECSC-EEC-EAEC, Brussels - Luxembourg, 1992

FOREWORD

This is the first Annual Progress Report of the European Community's 1989-1993 programme of research on the decommissioning of nuclear installations. It shows the status of implementation reached on 31 December 1990.

The Council of the European Communities adopted the programme in March 1989 /1/, considering: "Certain parts of nuclear installations inevitably become radioactive during operation; it is therefore essential to find effective solutions which are capable of ensuring the safety and protection of both mankind and the environment against the potential hazards involved in the decommissioning of these installations".

Also, the Council recognized that the 1984-88 programme of research on the decommissioning of nuclear installation, of which the current programme is a follow-up, "has yielded positive results and opened up encouraging prospects". The main publications relating to the results of the previous programmes are listed in Annex I.

The 1989-1993 programme covers the following areas:

A. Research and development projects concerning the following subjects:

- Area N° 1: Long-term integrity of building and systems;
- Area N° 2: Decontamination for decommissioning purposes;
- Area N° 3: Dismantling techniques;
- Area N° 4: Treatment of specific waste materials: steel, concrete and graphite;
- Area N° 5: Qualification and adaptation of remote-controlled semi-autonomous manipulator systems;
- Area N° 6: Estimation of the quantities of radioactive wastes arising from the decommissioning of nuclear installations in the Community.

B. Identification of guiding principles relating to:

- the design and operation of nuclear installations with a view to simplifying their subsequent decommissioning,
- the decommissioning operations with a view to making occupational radiation exposure as low as reasonably achievable,
- the technical elements of a Community policy in this field.

C. Testing of new techniques in practice:

- pilot projects,
- alternative tests,
- staff secondment.

The research is carried out by public organisations and private firms in the Community under cost-sharing contracts with the Commission of the European Communities. The Commission budget planned for this five-year programme amounts to 31.5 million ECU.

The Commission is responsible for managing the programme and is assisted in this task by the Management and Coordination Advisory Committee "Nuclear fission energy - Fuel cycle/processing and storage of waste" (see Annex II).

The 1989-93 programme has been started with the preparation of the four pilot dismantling projects, which concern:

- the Windscale Advanced Gas-cooled Reactor,
- the KRB-A Boiling Water Reactor (Gundremmingen),
- the BR-3 Pressurised Water Reactor (Mol),
- the AT-1 fuel reprocessing facility (La Hague).

Concerning Section A, R&D Projects, and Section C, Testing of New Techniques in Practice (other than the above-mentioned pilot projects), a Call for Research Proposals was published in June 1989 /2/, with a closing date of 30 September 1989.

Upon the Call for Research Proposals, 117 proposals were submitted, many of them jointly from proposers of different Member States. As the sum of EC participations exceeded the amount of funds to be allocated by a factor of 3.5, also valuable proposals were to be rejected or reduced. After the examination, 51 proposals were selected for contract negotiation.

By 31 December 1990, 41 research contracts had been concluded - they form the subject of the present report - and 12 contracts were at the stage of negotiation. Progress achieved in 1989, the starting year of the programme, was not important enough to form the subject of a separate report and has, therefore, been included in the present report.

This first progress report, covering the period of putting the programme into action, describes the work to be carried out under contracts concluded, as well as initial work performed and first results obtained.

For each contract, the Paragraph "C. Progress of Work and Obtained Results" was prepared by the contractor, under the responsibility of the Project Leader. The Commission wishes to express its gratitude to all scientists of the contractors who contributed to this report.

The Commission staff having edited the report are: E. Skupinski, R. Bisci, K. Pflugrad and R. Wampach.

B. HUBER(*)

R. SIMON(**)

References

- /1/ Council Decision of 14 March 1989 adopting a research and technological development programme for the European Atomic Energy Community in the field of the decommissioning of nuclear installations. OJ N° L 98, 11.04.1989, p. 33.
- /2/ Commission Communication concerning the research programme on the decommissioning of nuclear installations (1989 to 1993). Call for research proposals. OJ N° C 146, 13.06.1989, p. 12.

(*) Head of the Programme until January 1991.

(**) Head of the Programme since February 1991.

CONTENTS

	<u>Page</u>
1. AREA No. 1: LONG-TERM INTEGRITY OF BUILDINGS AND SYSTEMS	1
2. AREA No. 2: DECONTAMINATION FOR DECOMMISSIONING PURPOSES	2
2.1. On-line decontamination of complex components for unrestricted release, using ultrasonic waves in a flowing aggressive chemical agent	3
2.2. Development and optimisation of an easy-to-process electrolyte for electrochemical decontamination of stainless steel	7
2.3. Decontamination of large-volume nuclear components using foams	10
3. AREA No. 3: DISMANTLING TECHNIQUES	11
3.1. Effectiveness and long-term behaviour of cleanable high efficiency aerosol filters	12
3.2. Abrasive water jet cutting technique from the stage of laboratory into real application	18
3.3. Steel cutting using linear-shaped charges	23
3.4. Evaluation of the segmentation by various cutting techniques (plasma torch, arc saw, circular disc, etc.	28
3.5. Underwater thermal cutting techniques and associated remote-controlled manipulator systems	33
3.6. Development of a plasma arc torch and control/monitoring technique for the internal cutting of small bore pipework	39
3.7. Development of a steel cable to cut highly reinforced concrete with minimised water consumption	43
3.8. Assessment of state-of-the-art CO laser technology as an improved dismantling tool	45
3.9. Cutting of CO ₂ primary circuit pipes of G2/G3 reactors using explosive charges	47
4. AREA No. 4: TREATMENT OF SPECIFIC WASTE MATERIALS: STEEL, CONCRETE AND GRAPHITE	51
4.1. Development of a process for volume reduction of contaminated/activated concrete waste including pilot-scale testing with active waste	52
4.2. Investigations on recycling of radioactive non-ferrous aluminium and copper by melting process	57
4.3. Recycling of activated/contaminated reinforcement metal in concrete	59
4.4. Treatment and conditioning of radioactive graphite from nuclear installations	63
5. AREA No. 5: QUALIFICATION AND ADAPTATION OF REMOTE-CONTROLLED SEMI-AUTONOMOUS MANIPULATOR SYSTEMS	68
5.1. Robotic system for dismantling of the process cell of a reprocessing plant	69
5.2. Design, construction and testing of a manipulator for removing slag, measuring temperature and taking samples during melting of radioactive metal	72
5.3. Telerobotic monitoring, decontamination and size reduction system - TMDSRS	75
5.4. Adaptation and testing of a remotely controlled underwater vehicle	79
5.5. Test of long-range teleoperated handling equipment with different tools for concrete dismantling and radiation protection monitoring	81
5.6. Underwater qualification of RD 500 manipulator	85

6.	AREA No. 6: ESTIMATION OF THE QUANTITIES OF RADIOACTIVE WASTE ARISING FROM DECOMMISSIONING OF NUCLEAR INSTALLATIONS IN THE COMMUNITY	87
6.1.	Quick measuring methods of radionuclides in materials and wastes during decommissioning of nuclear installations	88
6.2.	Radiological aspects of recycling concrete debris from dismantling of nuclear installations	90
6.3.	Methodology to evaluate the risks of decommissioning operations on nuclear plants	93
6.4.	Definition of reference levels for exemption of concrete coming from dismantling	95
6.5.	Doses due to the reuse of very slightly radioactive steel	97
6.6.	Quantification of activity levels and optimisation of dose rate management to prepare stage 3 decommissioning of gas-cooled reactors	99
7.	SECTION C: TESTING OF NEW TECHNIQUES IN PRACTICE	100
7.1.	Pilot dismantling of the WAGR Phase 1: Dismantling of top bioshield refuelling standpipes, vessel top dome; trials of remote dismantling system	101
7.2.	Comparative assessment of alternative underwater remote operation and segmenting techniques for reactor vessel internals of KRB-A	107
7.3.	Pilot dismantling of the BR-3 PWR Phase 1: Decontamination of a primary circuit, realisation of cutting equipment, segmentation of first reactor internals	111
7.4.	Pilot dismantling of the FBR-fuel reprocessing facility AT-1 Phase 1: Dismantling of dissolution and extraction systems and of fission product storage tanks	121
7.5.	Pilot dismantling of the KRB-A BWR Phase 1: Dismantling of contaminated components of the reactor building and of activated internals of the reactor pressure vessel	127
7.6.	Decommissioning of the Risø hot cell facility	134
7.7.	Final clean-up of the PIVER prototype vitrification facility: decontamination of the hot cell	137
7.8.	Destruction of contaminated sodium of the primary circuit of experimental RAPSODIE reactor	141
7.9.	Decommissioning of the JEN-1 experimental reactor	146
7.10.	Development of segmenting tools and remote handling systems and application to the dismantling of VAK BWR reactor pressure vessel internals	151
7.11.	Melting of ferritic steel arising from the dismantling of the G2/G3 reactors at Marcoule in a furnace installed at the dismantling site	156
7.12.	Melting of alpha-contaminated steel scrap at industrial scale	158
7.13.	Demonstration of explosive dismantling techniques of the biological shield of the Niederaichbach nuclear power plant (KKN)	160
ANNEX I	List of publications relating to the results of the 1979-83 programme on the decommissioning of nuclear power plants	162
ANNEX II	List of publications relating to the results of the 1984-88 programme on the decommissioning of nuclear power plants	165
ANNEX III	Members of the Management and Coordination Advisory Committee "Nuclear Fission Energy - Fuel Cycle/Processing and Storage of Waste" ..	168

LIST OF ABBREVIATIONS - CONTRACTORS' NAMES AND ADDRESSES

AEA-Culch.	Atomic Energy Authority Technology Culcheth, Wigshaw Lane, UK-Cheshire WA3 4NE
AEA-Culh.	Atomic Energy Authority Technology Culham, UK-Abingdon, Oxfordshire OX14 3DB
AEA-Harw.	Atomic Energy Authority Technology Harwell, UK-Oxfordshire OX11 0RA
AEA-Wind.	Atomic Energy Authority Technology Windscale, UK-Seascale, Cumbria CA20 1PF
AEA-Winf.	Atomic Energy Authority Technology Winfrith, UK-Dorchester, Dorset DT2 8DH
BAI	Benelux Analytic Instruments, Vaartdijk 22, B-1800 Vilvoorde
BE	Battelle Europe - Battelle-Institut e.V. Frankfurt, Am Römerhof 35, Postfach 90 01 60, D-6000 Frankfurt am Main 90
BS	Brenk Systemplanung, Heinrichsallee 38, D-5100 Aachen
Bureau A+	Bureau A+, Godswaerdersingel 87, NL-6041 GK Roermond
CEA-Cad.	Commissariat à l'Energie atomique, Centre de Cadarache, B.P. N° 1, F-13108 St. Paul-lez-Durance
CEA-FAR	Commissariat à l'Energie atomique, Centre de Fontenay-aux-Roses, 60 Avenue du Général Leclerc, B.P. N° 6, F-92265 Fontenay-aux-Roses
CEA-Sac.	Commissariat à l'Energie atomique, Centre de Saclay, F-91191 Gif-sur-Yvette
CEA-Valrhô	Commissariat à l'Energie atomique, Centre de la Vallée du Rhône, B.P. N° 171, F-30205 Bagnols-sur-Cèze Cedex
CIEMAT	Centro de Investigaciones Energéticas Medioambientales y Tecnológicas, Avenida Complutense 22, E-28040 Madrid
COGEMA	Compagnie Générale des Matières nucléaires, B.P. 270, F-50107 Cherbourg
COMEX	Comex Nucléaire, 36 boulevard des Océans, F-13275 Marseille
DLR	Deutsche Forschungsanstalt für Luft- und Raumfahrt e.V., Pfaffenwaldring 38-40, D-7000 Stuttgart 80
ENEA	Ente per le Nuove Technologie, l'Energia e l'Ambiente, Viale Regina Margherita 125, I-00198 Roma
ENEL	Ente Nazionale per l'Energia Elettrica, Via R. Rubattino 54, I-20134 Milano
ENRESA	Empresa Nacional de Residuos Radioactivos S.A., Calle Emilio Vargas 7, E-28043 Madrid
ENSA	Equipos Nucleares S.A., Plaza del Marqués de Salamanca, E-28043 Madrid
EPC	Société anonyme d'Explosifs et Produits chimiques, rue de la Dynamite, F-13310 Saint-Martin de Crau
FHGF	Fachhochschule Giessen-Friedberg, Wiesenstrasse 14, D-6300 Giessen
Framatome	Framatome, Tour Fiat Cedex 16, F-92084 Paris-la-Défense
KA	Kraftanlagen Aktiengesellschaft, Im Breitspiel 7, Postfach 10 34 20, D-6900 Heidelberg
KEMA	N.V. Keuring van Elektrotechnische Materialen, Utrechtseweg 310, NL-6812 ET Arnhem
KfK	Kernforschungszentrum Karlsruhe, D-7514 Eggenstein-Leopoldshafen
KRB	Kernkraftwerk RWE-Bayernwerk GmbH, Postfach, D-8871 Gundremmingen

LAINSA	Limpiezas y Acondicionamientos Industriales S.A., El Payeter 13, E-46008 Valencia
NIS	NIS Ingenieurgesellschaft mbH, Donaustrasse 23, D-6450 Hanau
Noell	Noell GmbH-Nuklear Service, Postfach 6260, D-8700 Würzburg
NRPB	National Radiological Protection Board, Chilton, UK-Didcot, Oxfordshire OX11 0RQ
Radia	Radiacontrôle, Route de Lyon 44, F-38000 Grenoble
RNL	Risø National Laboratory, P.O. Box 49, DK-4000 Roskilde
RWE	Rheinisch-Westfälisches-Elektrizitätswerk AG, Kruppstrasse 5, D-4300 Essen
RWTHA	Rheinisch-Westfälische Technische Hochschule Aachen, Reutershagweg 4, D-5100 Aachen
SCK/CEN	Studiecentrum voor Kernenergie/Centre d'Etudes de l'Energie Nucléaire, Boeretang 200, B-2400 Mol
SG	Siempelkamp Giesserei GmbH & Co, Siempelkampstrasse 45, D-4150 Krefeld 1
Siemens- -KWU	Siemens AG, Bereich Energieerzeugung KWU, Hammerbacherstrasse 12-14, D-8520 Erlangen
Siemens- -BEW	Siemens AG Brennelementewerk Hanau, Rodenbacher Chaussee 6, D-6450 Hanau
SSP	Stangenberg, Schnellenbach und Partner GmbH, Postfach 10 28 69, D-4630 Bochum 1
Taywood	Taylor Woodrow Engineering Ltd., Ruislip Road 345, UK-Southall UB1 2QX
TNO	Netherlands Organization for Applied Scientific Research, P.O.Box 155, NL-2600 AD Delft
TÜV-Bay.	Technischer Überwachungsverein Bayern e.V., Westendstrasse 199, D-8000 München 21
TÜV-SWD	Technischer Überwachungsverein Südwestdeutschland e.V., Dudenstrasse 28, D-6800 Mannheim
UDA	Universidad de Alicante, Carretera de San Vicente del Raspeig s/n, E-03099 Alicante
UH-IW	Universität Hannover, Institut für Werkstoffkunde, PF 6009, D-3000 Hannover
VAK	Versuchsatomkraftwerk Kahl GmbH, Postfach 6, D-8756 Karlstein am Rhein

1. AREA No. 1: LONG-TERM INTEGRITY OF BUILDINGS AND SYSTEMS

A. Objective

It has been proposed that the dismantling of nuclear installations be delayed for periods ranging from several decades to about a hundred years. Thereupon, the radioactivity having largely died away, dismantling would be easier and the radiation exposure of the dismantling personnel would be less. The objective of this area is to determine the measures required for maintaining shut-down plants in a safe condition and to assess the radiological consequences of costs.

B. Research performed under the previous programmes (1979-1988)

The research work has been focused on the following main subjects:

- inspection of selected nuclear power plants and examination of materials as they exist therein, in order to determine the mode and pace of degradation;
- methodology studies of the measures necessary for maintaining plants in safe condition and for keeping the necessary ancillary equipment operable.

C. 1989-1993 Programme

Research in this area should be pursued with a constant moderate effort, enlarging the data base and exploiting the growing experience, in order to establish confidence in long-term forecasts. This involves in particular:

- collection of additional experimental data, e.g. repetition of past examinations after a time interval of about five years, in order to determine the rate of degradation and derive or check forecasting rules;
- comparison of confinement methods applied at specific shut-down nuclear installations in Member States;
- assessment of the merits of the Safe Storage option in the decommissioning of nuclear installations other than reactors.

D. Programme implementation

At the end of 1990, one research contract relating to Area No. 1 was at the stage of negotiation.

2. AREA No. 2: DECONTAMINATION FOR DECOMMISSIONING PURPOSES

A. Objective

The objective of this research is to develop and assess techniques for decontaminating surfaces of components and structures of nuclear installations that are past use. The main purpose of decontamination would be reduction of the occupational radiation exposure during dismantling of the contaminated item and/or reduction of the volume of radioactive waste.

B. Research performed under the previous programmes (1979-1988)

The following decontamination techniques have been developed and assessed:

- techniques using aggressive agents in liquid and gel-like form;
- electrochemical techniques using various electrolytes;
- hydromechanical techniques (high-pressure water lance, ultrasound);
- decontamination of concrete surfaces by flame jetting.

C. 1989-1993 Programme

Research in Area N° 2 should be pursued with a reduced effort focused on selected techniques. As a new subject, the use of liquid chemical agents carried by a large volume of air, in the form of foam or fog, should be developed with a view to decontaminating large-volume systems. Thermal techniques for removal of concrete surface layers should be investigated from a more general and fundamental view than in the past.

D. Programme implementation

At the end of 1990, three research contracts relating to Area No. 2 were at the stage of execution and three contracts were at the stage of negotiation.

2.1. ON-LINE DECONTAMINATION OF COMPLEX COMPONENTS FOR UNRESTRICTED RELEASE, USING ULTRASONIC WAVES IN A FLOWING AGGRESSIVE CHEMICAL AGENT

Contractor: ENEL, Milano
Contract No.: FI2D-0016
Work Period: July 1990 - June 1993
Project Manager: F BREGANI
Phone: 39/2/88 47 30 46 Fax: 39/2/88 47 39 15 or 88 47 34 96

A. OBJECTIVE AND SCOPE

Previous experiments made by ENEL on small valves, using aggressive chemicals, showed that zones with residual contamination remain inside the components.

The present work aims at solving this problem by enhancing the decontamination effectiveness with the action of focused ultrasonic waves. The main objective of the project is to set up and test in real conditions a new decontamination process based on the simultaneous use of ultrasonic waves and aggressive chemicals, with ultrasonic transducers applied outside the components.

This decontamination process, if its expected performances are confirmed, could become a useful tool in decommissioning activities. It should allow to increase the amount of decontaminable parts without having to spend many man-hours and man-rem (thus, without dismantling before decontamination).

The project is based on experimental investigations, mainly at laboratory scale but also in plant scale. It is the continuation of work performed by ENEL in the framework of previous EC programmes on decommissioning (contract DE-B-005, report EUR 9303; contract FI1D-0002, report EUR 12878).

B. WORK PROGRAMME

B.1. Evaluation, selection and acquisition of special ultrasonic transducers to be applied to complex components from outside.

B.2. Decontamination tests on specimens and components in the DECO loop.

B.2.1. Preparation of the DECO loop for testing; selection and characterisation of test specimens and components from Garigliano BWR.

B.2.2. Decontamination tests on contaminated specimens.

B.2.3. Decontamination tests on valves: radioactivity measurements, decontamination factor evaluation and secondary waste assessment.

B.2.4. Data analysis.

B.3. Decontamination and dismantling of a part of a real system of a nuclear power station

B.3.1. Preparation of the system part to be decontaminated.

B.3.2. Initial radioactivity characterisation.

B.3.3. Process design and configuration.

B.3.4. Decontamination.

B.3.5. Dismantling and final radioactivity measurements.

B.3.6. Evaluation of secondary wastes.

C. PROGRESS OF WORK AND OBTAINED RESULTS

Summary of main issues

The development of a new type of transducers which can be applied on the external surface of components of various geometry and thickness (e.g. valves, piping, fittings, etc.) has been started.

The type of transducers and wave generators to be used have been identified and their main design parameters have been defined. The executive design and the construction phases are in progress.

Progress and Results

1. Evaluation, selection and acquisition of special ultrasonic transducers (B.1.)

The ultrasonic transducers to be developed should basically meet these requirements:

- they should be applied on the external surfaces of components such piping of various diameters and thickness, fittings, valves etc.;
- they should be able to supply an high intensity ultrasound field inside the components above indicated; therefore the frequency and power of the ultrasound field should be varied as a function of the different operating parameters (e.g. component geometry and thickness).

Specifically for starting the present study, the following design parameters are considered:

- the transducers should be coupled to piping with a diameter ranging between 35 and 105 mm;
- the tubing thickness ranges between 5 to 20 mm;
- the power supply from the transducer inside the piping should be 300 W as a minimum and can be varied in a wide range;
- the ultrasound frequency should be between 20 to 40 kHz.

A market research, however, has evidenced that the transducers currently available do not meet contemporary all the requirements above indicated. As an example, high power commercial transducers are extensively used for metal surface working; however, in this application, the ultrasound transmission beyond the material surface is unimportant. Therefore key issues such as the determination of the characteristic resonance frequencies of the material in various working conditions are not commonly addressed.

Consequently the development of this new type of transducers requires a preliminary design study that has been committed to an ultrasonic laboratory which has developed a valuable experience in this field.

Specifically the design phase will address the following:

- simulation and design of the transducer and its coupler;
- simulation and design of the wave generator;
- coupling and calibration of the wave generator and the transducer.

The transducer will be of the Langevine type (e.g. precompressed) it basically consists (Fig. 1) of a piezoelectric ceramic material disc forced between two metallic blocks, it employs a conic wave guide to focus wave beam. The coupling to the piping surface will be made with an epossidic resin.

The optimum design configuration of the transducer will be defined by a computer study. Specifically the analysis of the equivalent loop of a piezoelectric transducer will be performed in order to define the working frequency which determines the highest coupling efficiency.

Similarly the design of the wave generator requires a computer modelling study (PS

pice programme). This program allows to evaluate the transducer impedance changes as a function of the different operating conditions. Moreover it simulates a coupling transformer which minimizes the impedance changes.

As a basis for the computer study the electric loop of a generator able to supply 3500 W either at 23 or at 40 kHz will be used.

An example of the study performed is shown in Fig. 2 where the calculated voltages as a function of the resonance frequencies in various transducer points are plotted. It can be noted that the lower voltages, e.g. the maximum coupling efficiencies, are obtained at a frequency of 22 kHz approximately.

Based on the finding of the computer simulation, the prototype transducer and generator will be then designed and built.

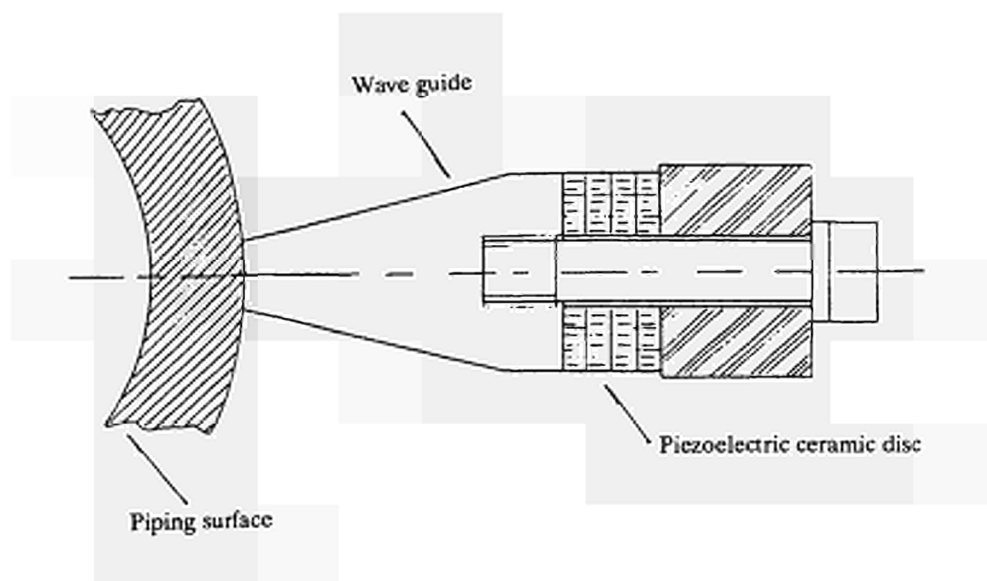

Figure 1 - Schemes of a piezoelectric transducers with a conic wave guide.

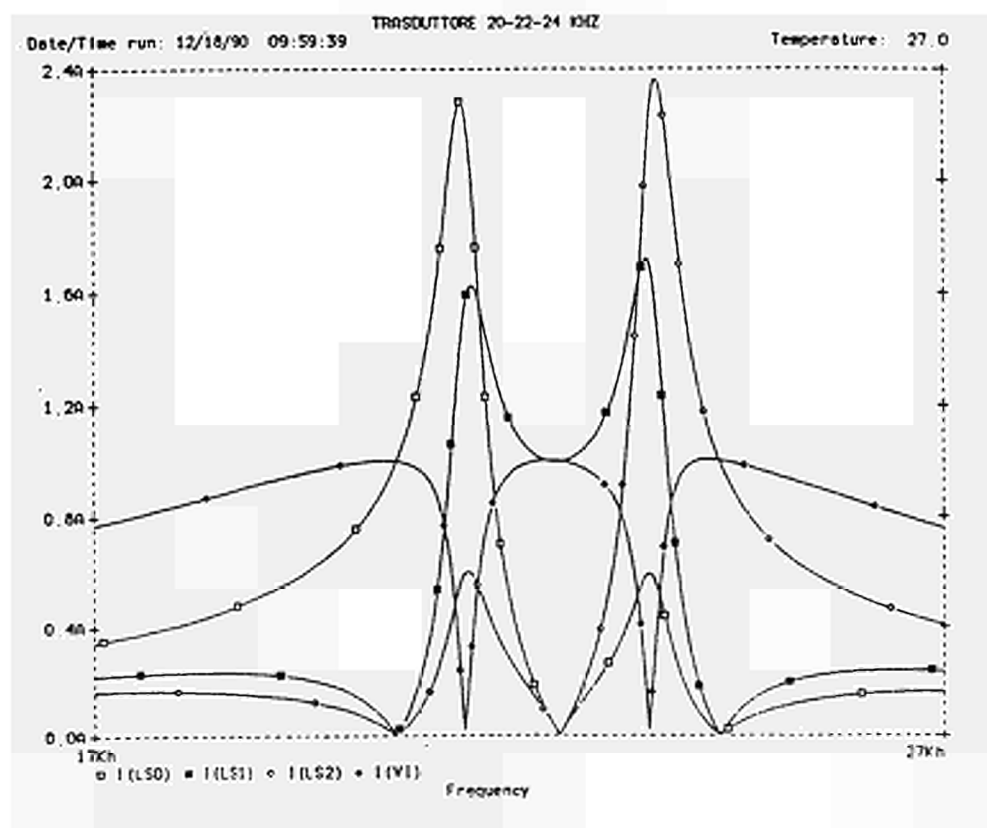

Figure 2 - Example of computer simulation studies. The calculated voltages vs. the resonance frequencies.

2.2. DEVELOPMENT AND OPTIMISATION OF AN EASY-TO-PROCESS ELECTROLYTE FOR ELECTROCHEMICAL DECONTAMINATION OF STAINLESS STEEL

Contractor: KA, Heidelberg
Contract No.: FI2D-0020
Work Period: July 1990 - June 1992
Project Manager: A STERINGER
Phone: 49/6221/39 42 50 Fax: 49/6221/39 47 07

A. OBJECTIVE AND SCOPE

This work aims at optimising an acetyl-acetone base electrolyte so that it can be used for electrochemical decontamination of stainless steels. Kraftanlagen Heidelberg developed the electrolyte under the preceding EC programme from 1984 to 1988, (contract No. FI1D-0004, report EUR 12383).

With regard to waste management and disposal, the obtained electrolyte came up to all expectations. An advantage of the organic electrolyte as compared to the phosphoric/sulphuric acid electrolyte is its long radiological service life (the activity settles out continuously). It is easy to convert the crystalline by-product (sediment) by high-pressure compaction into a form that is suitable for disposal. As only little residues of acetyl-acetonates are dissolved in the electrolyte, it is possible to considerably reduce the electrolyte volume by evaporation.

In tests with radioactive samples of carbon steel, the obtained results concerning removal effects, duration of treatment, surface quality, and decontamination factors, were satisfactory or good. However, pitting was stated in the tests with samples of stainless steel. As a consequence, the surface was not uniformly removed. Parts of the original surface were visible for a long time. This resulted in poor decontamination factors or long treatment times, respectively. In addition, larger volumes of secondary wastes were produced than with a uniformly removed surface. It is therefore required to optimise this electrolyte, if it is to be used for the treatment of stainless steel.

B. WORK PROGRAMME

- B.1. Quantitative investigations concerning the dissolution mechanism
- B.2. Optimisation of the aqueous electrolyte through replacing the potassium bromide by other conductive salts.
- B.3. Investigations into scattering and its effect on abrasion, surface quality and decontamination factor.
- B.4. Development of a water-free electrolyte.
- B.5. Decontamination tests with contaminated samples.
- B.6. Processing of spent electrolyte.

C. PROGRESS OF WORK AND OBTAINED RESULTS

Summary

Essentially, the analytical testing and practical experiments to develop a new electrolyte occur simultaneously. Only when the tests of dissolution mechanisms have been concluded, can the work of substituting the potassium bromide through other conductive salts, the examination of the scatter behaviour and the influence on removal efficiency, surface quality, decontamination effect and the development of a non-aqueous electrolyte be assessed.

There were many conductive salts that showed positive results. Satisfactory removal rates along with a good anode current yield could be achieved. It should be possible to improve the results through optimizing various parameters. A modified viscosity did not affect the electrolyte scattering, and the removal efficiency.

The investigations aiming at the development of a non-aqueous electrolyte are not to be restarted before completing positive tests with the aqueous electrolyte.

Progress and Results

In the course of this project, an electrolyte on the basis of acetylacetonate is to be optimized, for use in the electrochemical decontamination of stainless steels. Figure 1 shows the lists of the process parameters and the desirable process features of the easy-to-process electrolyte.

1. Quantitative investigation concerning the dissolution

In order to exclude selective dissolution mechanisms phases, it is necessary to determine the quantitative dissolution of the alloying constituents, dependent on the time of treatment. To review local corrosion, the corrosion current is measured.

The investigations of the dissolution mechanism are supported by galvanostatic and potentiostatic measuring methods.

1.1. Results to date

First investigations of the dissolution mechanisms showed that the metalion concentration corresponds at any point of time to the percentage of the stainless steel alloying constituents. The concentration of Cr, Ni and Fe, throughout the test time and at various strengths of the electrical current, is specified in Fig. 2.

Despite pitting, there were no signs of a selective dissolution of the various alloying constituents.

There are certain indications that, in the presence of inhibitor anions, the anodes are dissolved by halides, without any pitting.

1.2. Perspectives

The investigations of the selective dissolution mechanism should be continued.

Further investigations to analyse the influence of inhibitors on the pitting behaviour of specific anions at the anode.

The results obtained in the tests are to be compared to the tests described in the relevant technical literature.

2. Optimisation of aqueous electrolytes through replacing the potassium bromide by other conductive salts

This step is to investigate various measures that are likely to reduce or entirely eliminate the aqueous electrolyte's tendency to pitting. To this end new conductive salts are being investigated as a KBr replacement.

In addition, it is aimed at finding inhibitors which prevent pitting, and with the high removal rate remaining unchanged.

2.1. Results to date

Out of a great number of possible conductive salts and mixtures thereof used to replace KBr, satisfactory and even very good results were obtained in the test below. The results are shown in Table 1.

2.2. Perspectives

The positive effect of the various conductive salts and mixtures thereof remains to be analysed. The results obtained were checked for a possible solid separation in the form of the $\text{Me}^{+n}(\text{acac})_n$ which depends on the pH value. Moreover, the electrolyte service life must be investigated in more detail.

The results obtained during the investigation of the dissolution mechanism and the relevant factors will greatly influence any further steps in the development of an electrolyte where KBr is replaced by other conductive salts. The first results are expected by about mid-1991.

3. Investigations of scattering behaviour and the effects on removal efficiency, surface quality and decontamination factors

This step is to investigate the effect of viscosity on the scattering power and removal efficiency of the new aqueous and non-aqueous electrolytes. The respective tests are to accompany electrolyte development.

3.1. Results to date

To the electrolytes on the basis of acetylacetone containing KBr, CaCl_2 and FeCl_3 , gelatin and polyglycol was added in order to increase the viscosity. No effect on the scattering power and removal behaviour was determinable.

3.2. Perspectives

The tests will be continued only when the other work packets promise no success.

4. Development of a non-aqueous electrolyte

An electrolyte is to be developed in which the water is entirely replaced by an organic solvent, in order to preclude pitting.

4.1. Results to date

In this test series, the water was replaced by methanol. During the tests, the anode current yield lay from 89 to 94 %, whereas the thickness losses were between 50 and 75 % with removal rates of 1.5 - 3.4 $\mu\text{m min}^{-1}$. Methanol must be added from time to time, to make up for the evaporation losses. The service life of the electrolyte based on MeOH is extremely short.

4.2. Perspectives

For the time being, the investigations aiming at the development of a non-aqueous electrolyte have been stopped, because the dissolution mechanism in aqueous electrolytes must be defined. The tests will be made in parallel as long as this is possible. First results are expected in the second half of 1991.

Tab. 1

Results of the different conductive salts used to replace KBr

conductive salt	anode current yield %	removal rate $\mu\text{m min}^{-1}$	remark
Na_2SO_4	40	1,6 - 2,59	smooth surface
CaCl_2	96,5	2,13	smooth surface with shallow dimples
$\text{FeCl}_3 +$ $\text{CrCl}_3 +$ CaCl_2	108	3,86	smooth surface with a cavity
TBA-Br	< 90	> 1,5	short service life removal rate decreased continually
$\text{KH}_2\text{PO}_4 +$ $\text{Na}_2\text{SO}_4 +$ Ethanolin	55 - 100	0,05 - 0,57	good - very good
$\text{KH}_2\text{PO}_4 +$ Na_2SO_4	57 - 59	0,17 - 0,33	very good
$\text{Na}_2\text{SO}_4 +$ $\text{KH}_2\text{PO}_4 +$ Ethylendiamin	66	0,38	very good
$\text{KH}_2\text{PO}_4 +$ Na_2SO_4 Ethanolin KBr	67 - 73	0,28 - 0,48	good

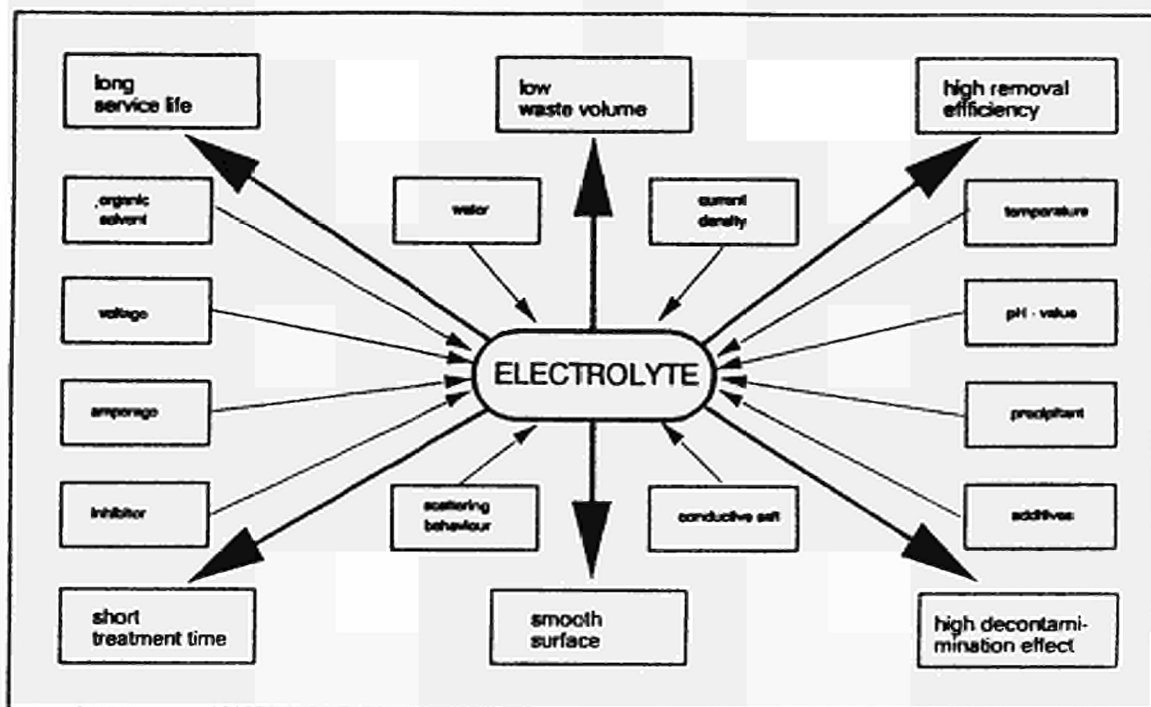

Fig. 1: The process parameters and the desirable process features of the optimized electrolyte

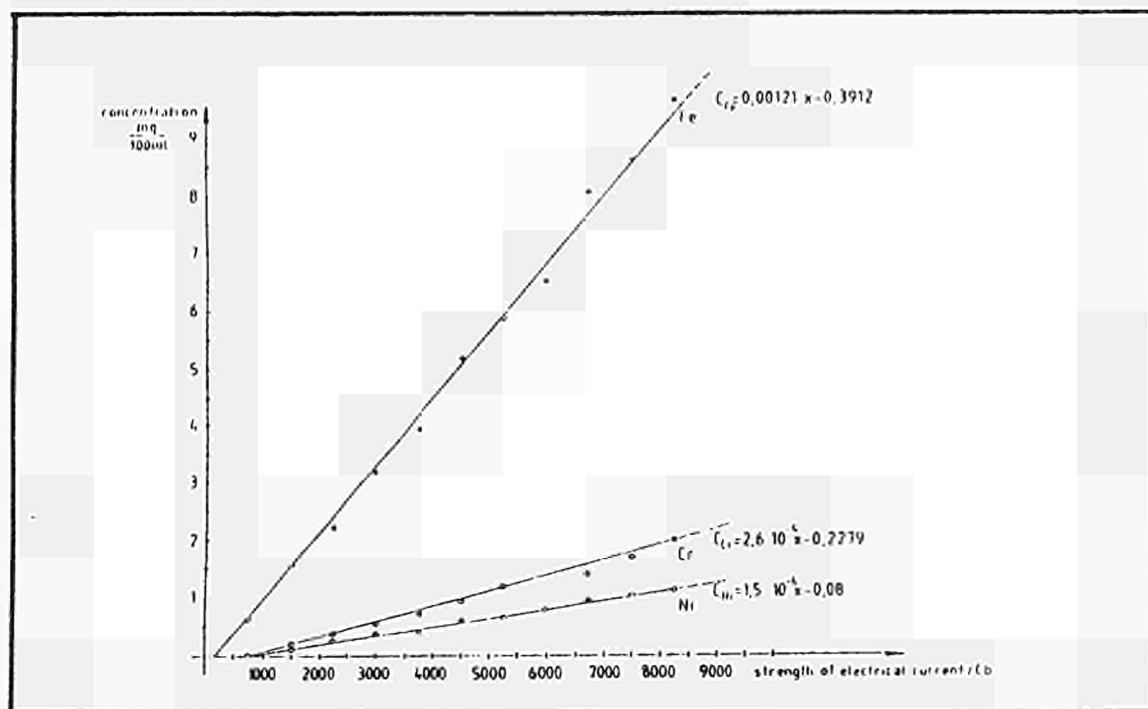

Fig. 2: Distribution of the Fe, Cr and Ni concentration over the time at various strengths of the electrical current

2.3. DECONTAMINATION OF LARGE-VOLUME NUCLEAR COMPONENTS USING FOAMS

Contractors: CEA-Cad, AEA Winf
Contract No.: FI2D-0035
Work Period: October 1990 - March 1993
Coordinator: J P GAUCHON, CEA-Cad
Phone: 33/42 25 61 93 Fax: 33/42 25 35 45

A. OBJECTIVE AND SCOPE

There are only a few methods for in-situ decontamination of very large components usually in complex forms, such as large valves, reservoirs, heat exchangers, turbines, vessels, boilers.

The foam application processes have the major advantage of using only small quantities of liquid and being able to forcefully penetrate everywhere. Suitable chemical reagents are added to the foam, which acts a dynamic carrier.

In this contract, a technique of permanent foam circulation will be sought, so that decontamination can last for several hours in order to be as effective as possible and to use only a minimum amount of liquid. Decontamination factors of over 100 are expected.

The objectives of the programme are to:

- develop and demonstrate an effective in-situ decontamination technique for large-volume components using chemical foams containing decontamination reagents;
- minimise the volume of secondary wastes produced and demonstrate a treatment and disposal route, e.g. electrolytic processes, wet oxidation.

B. WORK PROGRAMME

- B.1. **Chemical foam formulation containing decontamination reagents (AEA and CEA)**
- B.2. **Foam production and development of a circulation system (AEA and CEA)**
- B.3. **Small pilot tests to qualify the decontamination method (CEA)**
- B.4. **Secondary wastes treatment (AEA)**
- B.5. **Design, construction and operation of a prototype foam production and circulation rig; non-radioactive demonstration (AEA and CEA)**
- B.6. **Industrial application by radioactive tests on a 25 m³ contaminated vessel from Winfrith Steam Generating Heavy Water Reactor (AEA)**

C. PROGRESS OF WORK AND OBTAINED RESULTS

No significant work was performed in this just starting contract.

3. AREA No. 3: DISMANTLING TECHNIQUES

A. Objective

The objective of this research is the development of the special techniques needed for dismantling the large steel components (e.g. reactor pressure vessel) and reinforced-concrete structures (e.g. reactor shielding) of redundant nuclear installations, account being taken of the particular requirements due to radioactivity.

B. Subjects of the research performed under the previous programmes (1979-88)

The following main dismantling techniques were developed and tested:

- thermal techniques such as plasma-arc and oxygen cutting and cutting by laser beam;
- mechanical techniques such as abrasive water jet cutting;
- explosive techniques for the dismantling of concrete structures.

C. Programme 1989 to 1993

Research in this Area should be pursued vigorously with particular respect to the:

- development of the arc-saw technique for cutting thick-walled steel components;
- further development of the electrolytic technique for segmenting thick steel sections;
- comparative assessment of various segmenting techniques with reference to standard cutting tasks;
- full-scale testing of controlled explosive techniques for dismantling of concrete and metal structures.

D. Programme implementation

At the end of 1990, nine research contracts relating to Area No. 3 were at the stage of execution and two contracts were at the stage of negotiation.

3.1. EFFECTIVENESS AND LONG-TERM BEHAVIOUR OF CLEANABLE HIGH EFFICIENCY AEROSOL FILTERS

Contractor: TÜV Bayern
Contract No.: FI2D-0007
Work Period: July 1990 - June 1992
Project Manager: P BOEHM, TÜV Bayern.
Phone: 49/89/519 01 65 Fax: 49/89/519 02 80

A. OBJECTIVE AND SCOPE

Because of the high quantity of dust generated by various cutting/dismantling processes, frequent replacement of high-efficiency sub-micron particulate air filters is necessary. If such filters could be cleaned during service, costs for the replacement of the filters, radiation exposures and the amount of secondary waste could be reduced.

The effectiveness in long-term operation (approx. one year) of high-efficiency submicron particle air filters will be investigated in the framework of the dismantling of the Niederaichbach nuclear power station (KKN) in Germany.

A high-efficiency submicron particle air filter system will be exposed to heavy dust generation during the remote-controlled dismantling of KKN primary circuit pressure tubes, and therefore must be dedusted periodically. The dust is radioactively charged (essentially Co-60 and Fe-55). The radioactivity could amount to approx. 1.10^5 Bq/g (pressure tubes and moderator tank) and the dose rate to 0.1 Sv/h. There is at present no experience on the effectiveness and the long-term behaviour of high-efficiency submicron particle air filters that are dedustable during operation.

B. WORK PROGRAMME

B.1. Installation of the filters

B.2. Determination of the main parameters of the clean filter station

B.3. Continuous measurements (pressure pickups, air humidity and temperatures) during cutting of KKN primary cooling circuit (activated cooling channel tubes inside the reactor vessel)

B.4. Final evaluation including radiation exposure of workers, secondary waste arisings, specific costs, effectiveness and long-term behaviour of the filter system.

C. Progress of Work and Obtained Results

Summary

Putting the filter plant with cleaning equipment into operation was completed in November 1990. The measuring instruments for measuring the pressure differences of the high efficiency aerosol filters (S-filters) were installed in December 1990. Remote-controlled dismantling in the KKN commenced in January 1991. Measuring instruments for measuring relative air humidity and the temperature of clean air are currently being installed.

Progress and Results

The room ventilation plant in the Niederaichbach nuclear power plant consists of a supply air plant and various exhaust air plants.

In order to retain radioactive dust particles, the exhaust air is conducted through a filter plant with two filter stages (HFA). Both filter stages contain high efficiency aerosol filters. The filtered exhaust air is discharged into the environment through an outgoing air flue. The maximum exhaust air flow rate is 110,000 m³/h.

During remote controlled dismantling the exhaust air flow contains a high percentage of dust particles. This exhaust air flow is additionally sent through a filter plant with cleanable filters. This filter plant contains a filter stage with high efficiency aerosol filters.

This means that during remote controlled dismantling, the exhaust air volume flow, with its high dust particle content, is conducted first through the filter plant with the cleanable filters (ARFA), then through the filter plant with the two aerosol filter stages.

The maximum exhaust air volume flow through the ARFA is 30,000 m³/h.

The ARFA consists of six filter bank housings, each containing five filter bank units. Each filter bank unit has shut-off valves on the dust air side and on the clean air side. The shut-off valves on the clean air side are closed automatically when the ARFA is not running.

In each of the thirty filter bank units is a filter box with a high efficiency aerosol filter.

The flow circulation of the exhaust air being filtered is shown in the schematic representation of the plants (figures 1, 2 and 3).

The aerosol filters are cleaned with compressed air. Blast air supports moved by compressed air cylinders are moved back and forth along the entire width and length of the aerosol filters.

The compressed air emitted from the blast jets of the support blows the dust particles accumulated in the aerosol filters into dust boxes. The compressed air requires a maximum operating pressure of 6 bar.

The aerosol filters and blast jet supports can be inspected through windows in the filter bank housings.

An operating unit monitors the pressure differences

of the aerosol filters, using the pressure difference to control cleaning.

Only two aerosol filters are cleaned at any time. The shut-off valves on the clean air side are closed automatically during this process.

The starting period of the ARFA involved the following measurements and tests:

- Measurement of the supply and exhaust air flow rates.
- Measurement of the pressure differences at the clean aerosol filters.
- Measurement of the pressure in the reactor building and in the dismantling house.
- Measurement of the static pressures on the suction and pressure sides of the ventilators.
- Measurement of the temperatures and relative humidity of the supply and exhaust air flows.
- Leakage test on the filter bank housing.
- Leakage test on the shut-off valves on the clean air side.
- Leakage test of the sealing band of the filter boxes on the dust air side.
- Visual check of the function of the blast jet supports for cleaning the aerosol filters.
- Measurement of ventilator speed.
- Test of electrical locking functions.
- Test of fault indication.

There has been no automatic cleaning of the S-filters so far. Due to the dismantling schedule of KKN, increased dust in the waste air is not expected until mid-1991 (the beginning of the dismantling of the Moderator-Tank by grinding).

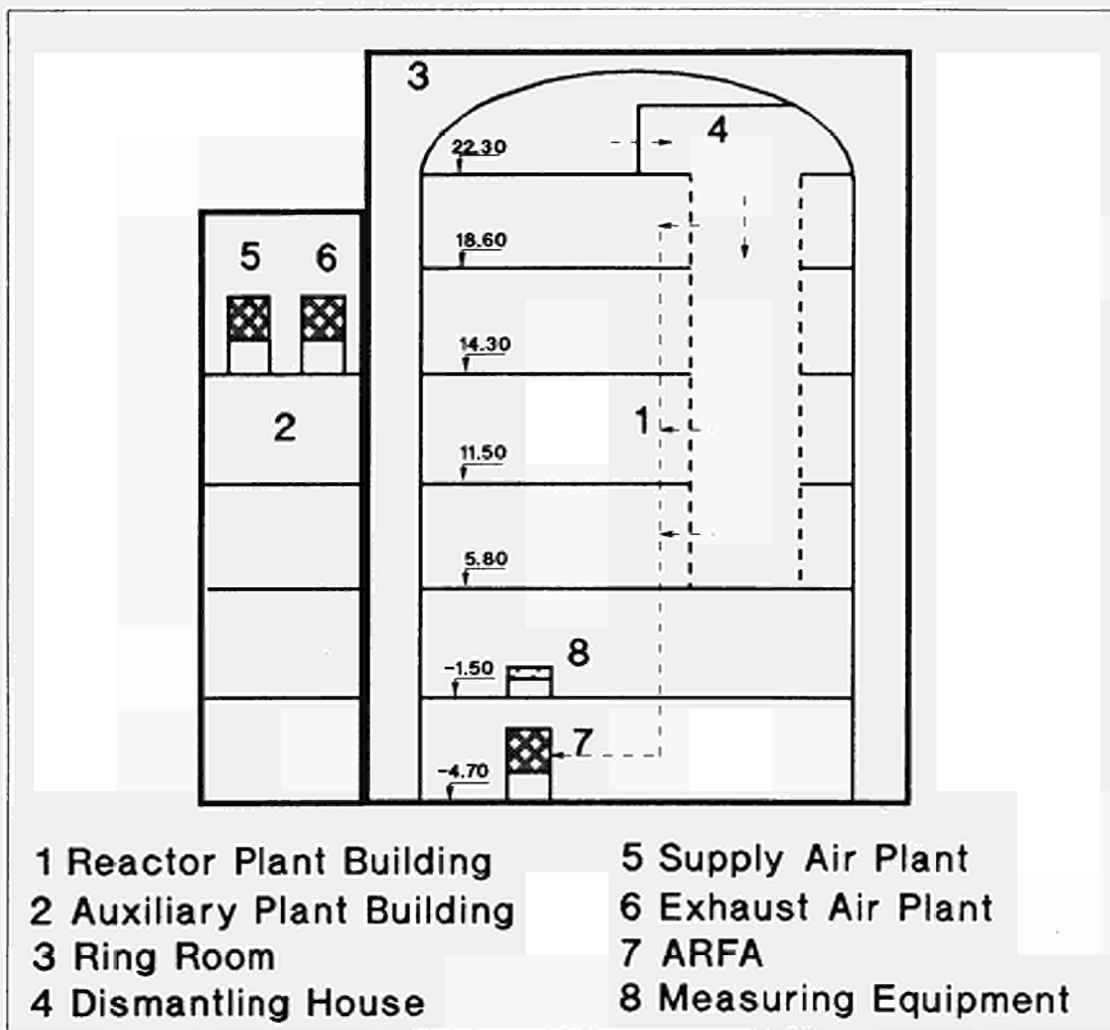
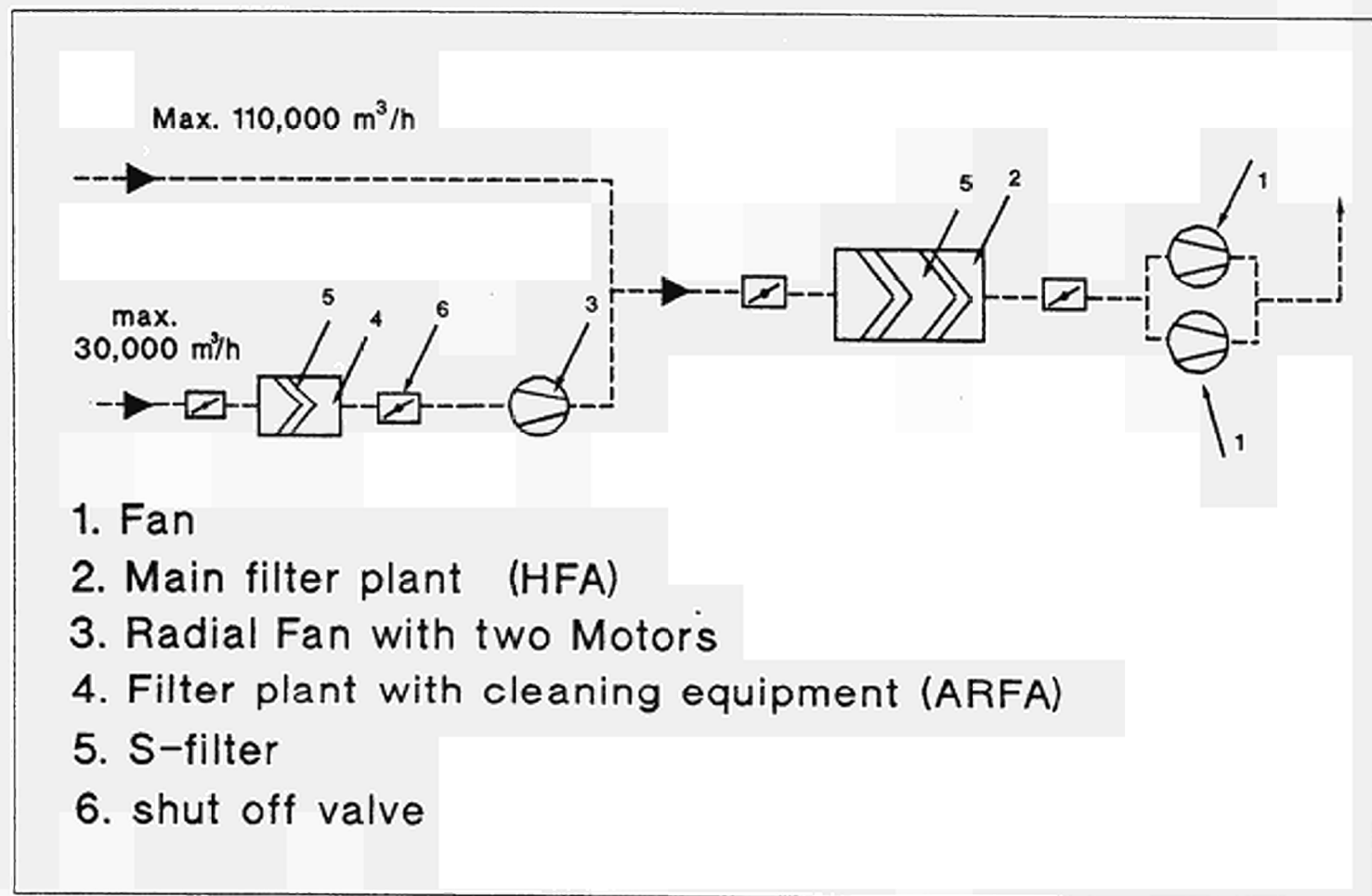

Figure 1: Reactor and auxiliary plant building



grafical symbols DIN 1946

Figure 2: Diagram of the air flow circulation

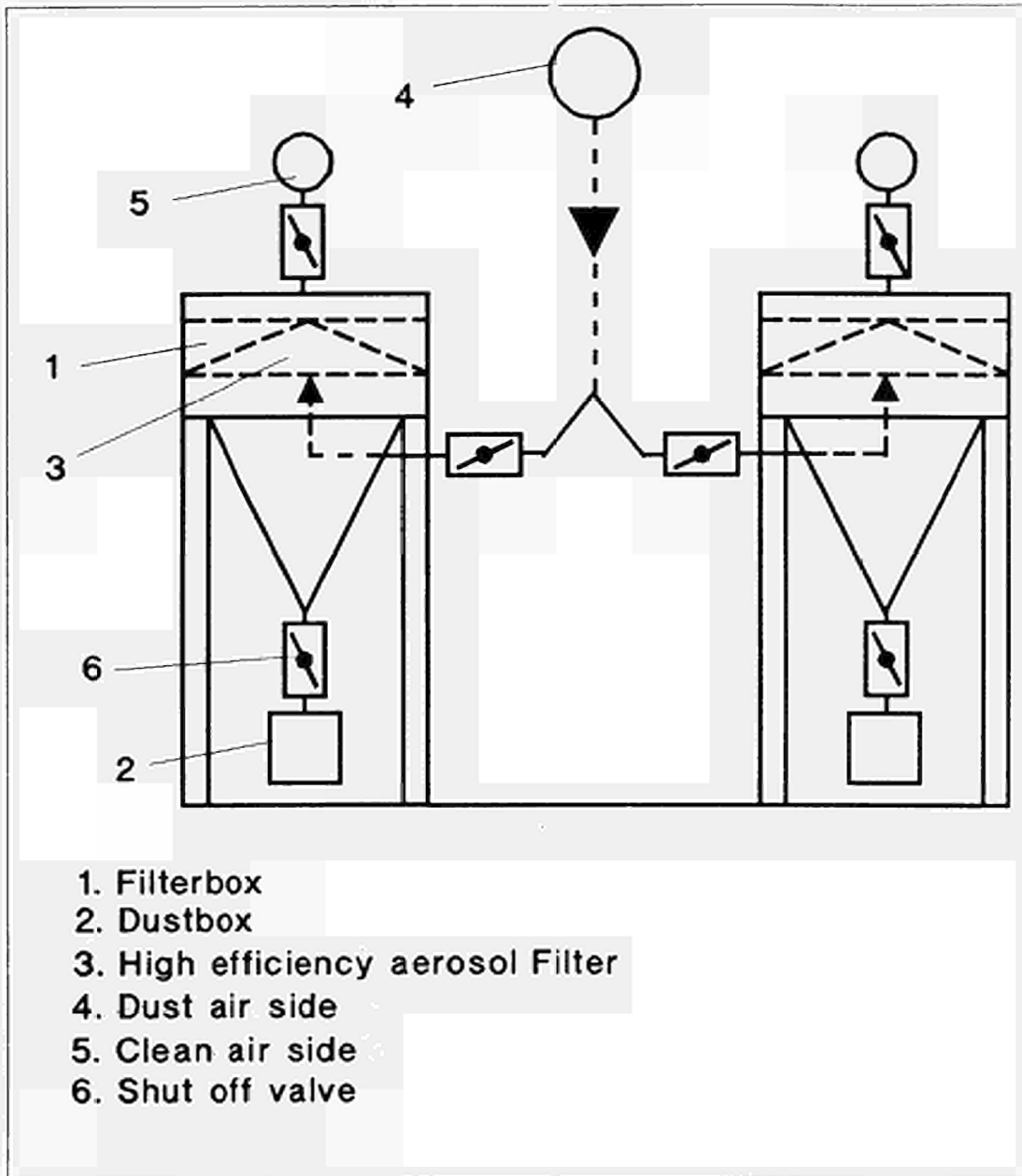

Figure 3: Diagram of the air flow circulation

3.2. ABRASIVE WATER JET CUTTING TECHNIQUE FROM THE STAGE OF LABORATORY INTO REAL APPLICATION

Contractors: UH-IW, CEA-Sac
Contract No.: FI2D-0009
Work Period: July 1990 - June 1992
Coordinator: H LOUIS, UH-IW,
Phone: 49/511/762 4320 Fax: 49/511/762 3456

A. OBJECTIVE AND SCOPE

In order to qualify the cutting by abrasive water jets for application in contaminated or activated environment, the cutting techniques developed for laboratory application (CEC contracts FI1D-0069 and FI1D-0067) are to be adapted for remote-controlled application. Secondly, concepts for the handling of the secondary waste are to be developed and proved.

First, the existing abrasive cutting head is to be adapted to remote-controlled work under a water shield up to 15 m, in an inaccessible environment. For this application, methods have to be implemented and proved to control the cutting operation, for instance the state of wear and the cutting results (e.g. depth of the kerf, cutting through). Additionally, parts showing wear are to be remotely replaced so as to allow long-term reproducible operation.

The second step concerns investigations on the secondary waste. Besides a calculation of the composition and amount of secondary waste depending on cutting parameters, strategies will be developed and tested to catch the waste as close as possible at the place of production. Filtration techniques to separate abrasives and cut material from water and air will be adapted from other cutting techniques and will be tested.

All tests will be carried out under non-radioactive conditions, but at real scale in special water basins. The aim of this research work is to set up a tool which is suitable for work under realistic conditions. A control system and the remote replacement of worn parts are further important aims of this research work.

B. WORK PROGRAMME

B.1. Definition of cutting parameters for decommissioning purposes (UH-IW)

B.2. Development of controlling systems for processes parameters and the cutting result (UH-IW)

- B.2.1. Preparation of a two-dimensional feeding mechanism for underwater cutting tests.
- B.2.2. Development of an on-line controlling system to detect the state of wear inside the cutting head.
- B.2.3. Development and adaptation of controlling methods to verify the cutting result during or just after cutting.
- B.2.4. Design of a cutting head which includes controlling systems, cutting tests to qualify the sensor systems.

B.3. Development of methods to remotely replace worn parts of the cutting head under water (UH-IW)

B.4. Characterisation and handling of secondary waste

- B.4.1. Preparation of test facilities for measuring aerosols and suspended particles when cutting in air and under water (UH-IW).
- B.4.2. Measurement and characterisation of the secondary emissions when cutting or kerfing in air or under water (CEA).
- B.4.3. Development of methods to lower the spreading out of emissions in air or under water (UH-IW).
- B.4.4. Cutting tests to determine the efficiency of measures to lower the emissions and to determine the filtration systems (UH-IW, CEA).

C. PROGRESS OF WORK AND OBTAINED RESULTS

Summary of main issues

In the first period parameters have been fixed for abrasive water jet cutting for decommissioning purposes. Special demands on the cutting technique like underwater applicability because of radiation protection and minimisation of waste must be noticed. To reach an optimal cutting efficiency regarding water and abrasive consumption it is useful to work on a high pressure level with a small nozzle diameter.

For dismantling jobs a remote-controlled operation is necessary, therefore sensor systems are required to supervise the tool function and the cutting result. A water basin was built to test sensor equipment. A method was found to control the diameter of the focusing nozzle (increasing by wear) by measuring the sucked-in air flow.

Further tests will be carried out to optimise the method of noise analysis for controlling the cutting result.

Progress and results

1. Definition of cutting parameters (B.1.)

For the application of abrasive water jets in contaminated environment the reduction of secondary waste is very important. So cutting parameters are useful which are quite different from "normal" industrial applications. Additionally also the use of the tool under water creates special demands on the cutting technique regarding the sensitiveness against changing the working distance, for example.

Results from contract FIID-0069 /ref. 1/ have shown that there is an optimal nozzle size to reach the best cutting efficiency regarding the used amount of water. This efficiency increases with increasing water pressure. Fig. 1 shows the optimal nozzle diameter for a water pressure of 2400 bar. The optimal nozzle size is 0.2 mm, increasing the diameter effects a decrease in cutting performance related to the used water flow rate /ref. 2/.

A similar effect is given for the abrasive flow rate. Increasing the flow rate effects an increase in cutting depth. But when this cutting depth is related on the used abrasive flow rate, there is an optimal flow rate at very low rates (fig. 2). Using for example only 2 g/s for a certain cut means the lowest production of abrasive waste, but the cut lasts longer than using a higher abrasive flow rate.

For the application in contaminated environment it is necessary to cut under the protection of a water shield. In that case the abrasive water jet is sensitive against the variation of the working distance. Fig. 3 gives the results of cutting tests comparing application in air and under water. The momentum loss under water is only small when using a short nozzle-sample distance. For distances about 25 mm there is only half the cutting performance than using 2 - 5 mm distance. This effect results in high demands on the handling system and the sensor system to keep and

control the working distance.

2. Development of controlling systems (B.2.)

2.1. Preparation of a two-dimensional feeding mechanism

An existing feeding mechanism had to be modified to carry out two-dimensional cutting tests with abrasive water jets under water. So a water basin was modified which allows the testing of sensor systems to detect the cutting result (cutting through or kerfing). Two-dimensional cutting tests are necessary to check the effect of changing the cutting direction on the sensor signals.

Additionally this equipment allows to filter the water and to analyse the suspended particles. Tests will be carried out together with CEA-Saclay to quantify the amount of waste (B.4.).

2.2. Development of an on-line controlling system to detect the state of wear inside the cutting head

When operating in inaccessible environment it is necessary to control the state of the tool. In the case where undue worn parts have to be removed water jet nozzle and focusing nozzle especially have to be controlled to reach a sufficient cutting efficiency at every time.

The wear of the water jet nozzle can be supervised by measuring the water flow rate. In case of wear or chipping the water flow rate increases when the pressure is constant.

The wear of the focusing nozzle can be calculated by controlling the air flow rate sucked-in by the injection cutting head. Fig. 4 shows the effect of the focusing diameter on the air flow sucked-in. To measure this air flow rate a flow meter is necessary in the transportation tube of the abrasives. So the abrasives have to pass the flow meter together with the air where it will be causing wear.

Otherwise the abrasives can be stored in a closed vessel and the air sucked-in in this vessel can be measured.

On the other hand the flow rate and so the diameter of the nozzle can be calculated by measuring the pressure drop in the transportation tube. This method is very easy to realise: Two pressure sensors are adapted in different positions of the transportation tube, the pressure drop is proportional to the flow rate.

References

/1/ Haferkamp, H.; Louis, H. and Meier, G.:

"Weiterentwicklung des Abrasivstrahl-Schneidverfahrens zum Trennen ferritischer und austenitischer Stähle unter Wasser", EUR 12684 DE

/2/ Haferkamp, H.; Louis, H. and Meier, G.:

"Submerged Cutting of Steel by Abrasive Water Jets"

Proc. of the 1989 Intern. Conf. on Decommissioning of Nuclear Installations, CEC, EUR 12690

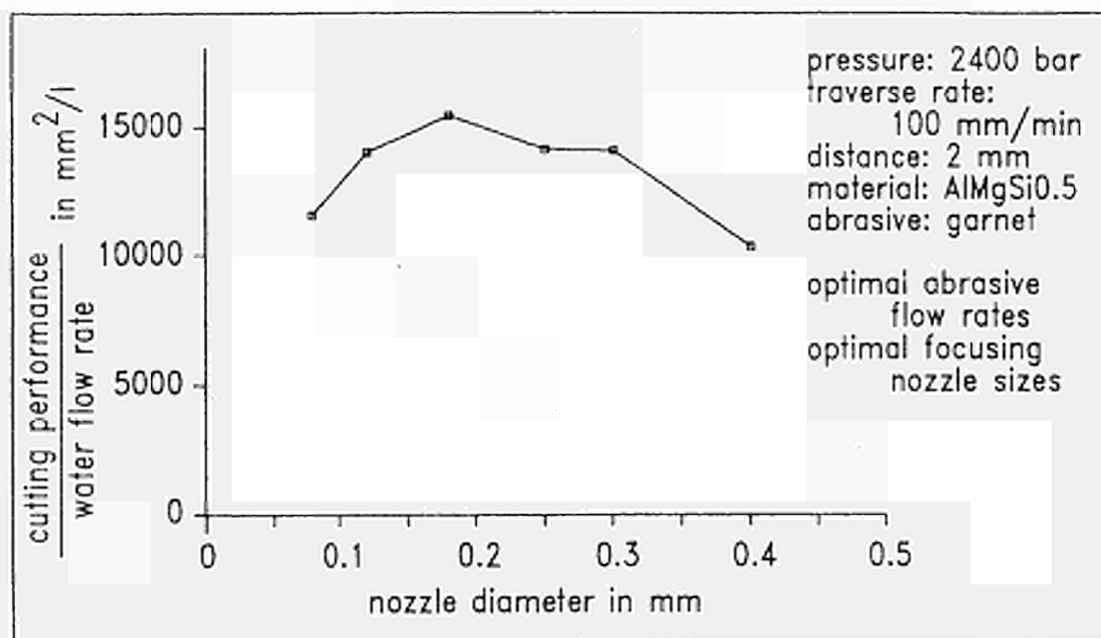

Figure 1 Effect of water flow rate on cutting efficiency

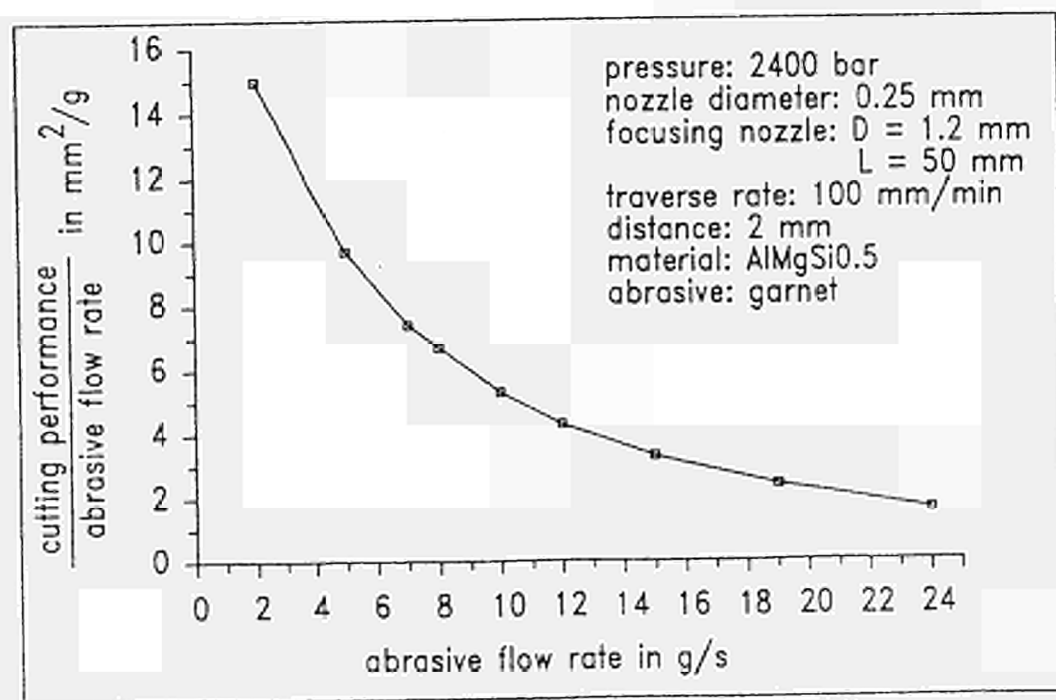

Figure 2 Effect of abrasive flow rate on cutting efficiency

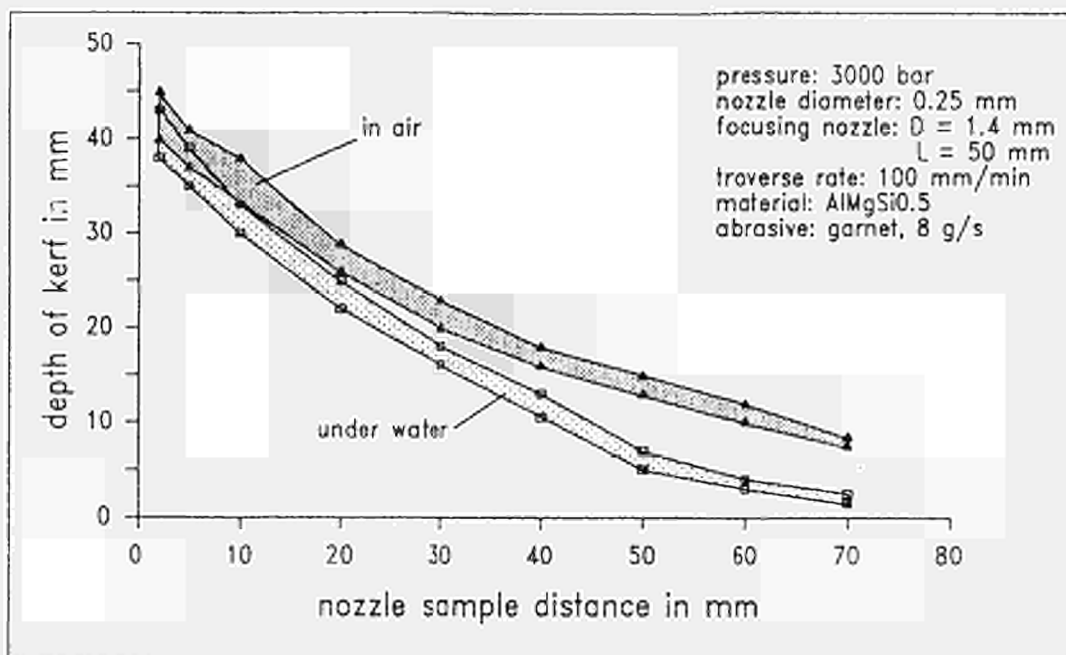

Figure 3 Effect of nozzle-sample distance on depth of kerf

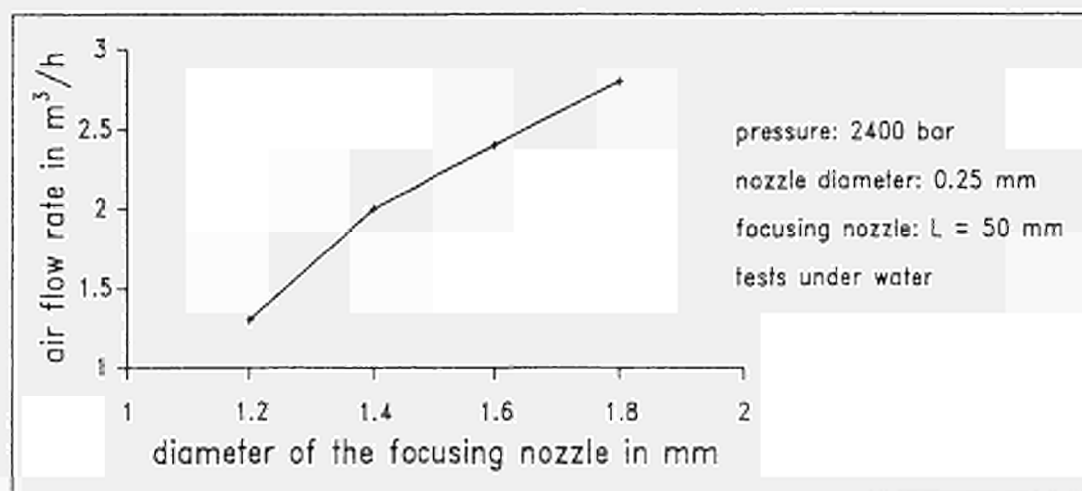

Figure 4 Effect of diameter of the focusing nozzle on the flow rate of the sucked-in air

3.3. STEEL CUTTING USING LINEAR-SHAPED CHARGES

Contractor: OTO MELARA
Contract No.: FI2D-0010
Work Period: July 1990 - June 1993
Project Manager: G PEZZICA,
Phone: 39/187/40 91 28 Fax: 39/187/42 10 26

A. OBJECTIVE AND SCOPE

Various types of cutting charges already exist, but mainly for cutting of few millimetres thick material.

The research work will therefore focus on the development of a high performance cutting charge minimising the damages to surrounding structures for the dismantling of thick-walled steel components (ranging between 10 to 250 mm thickness), e.g. pipes, reactor pressure vessels. The work will include studies and experiments at small and large scale, as well as a study to possibly eliminate or minimise undesired secondary effects caused by the projection of splinters at high speed.

Specific data will be produced on costs, work time and secondary waste arisings from the application of this steel cutting technique.

It is expected that the project will result in an economical and dose-rate tolerant cutting technique particularly suitable for dismantling work in inaccessible places.

B. WORK PROGRAMME

B.1. Determination of basic charge parameters

- B.1.1. Theoretical assessment to characterise high performance cutting charges.
- B.1.2. Manufacture of charges and execution of tests.
- B.1.3. Analyses of the experimental data compared with the theoretical results, conclusions on first phase.

B.2. Optimisation of the cutting charges

- B.2.1. Theoretical assessment to further optimise important parameters.
- B.2.2. Manufacture of charges and execution of tests with measurements of blast effects in the air, of ground vibrations, photographs from an ultra-rapid framing camera and of flash X-ray tubes.
- B.2.3. Analyses of the experimental data with a view to specify high-performance charges.

B.3. High-performance cutting charges specifications and tests.

- B.3.1. Theoretical assessment of the final configuration of high-performance cutting charges and specification of 8 tests (in order to determine the scaling law).
- B.3.2. Manufacture of charges and execution of large-scale tests in special areas allowing large amounts of explosives.

B.4. Final evaluation including specific data on costs, work time and secondary waste arisings.

C. Progress of Work and Obtained Results

Summary

The research work started in November 1990, with a delay of 4 months with respect to the contractual starting date (01.07.1990), due to the delayed contract signature.

The preliminary theoretical study, (B.1.1.), has been completed. By means of the non-linear finite-differences computer code PISCES 2D, six different fundamental configurations of cutting charges have been investigated. A detailed study has been performed by using the same hydrodynamic computer code PISCES 2D but linked with the analytical computer code OTOSC1 which was "ad hoc" developed for studies on shaped charges. During this second study eight different configurations have been investigated and eight cutting charges defined by using both the published data and the results of the computer simulations.

The manufacture of the two first batches of four charges each has been started. Every charge corresponds to a reference configuration. The best of two different manufacturing processes will be identified. This action, included in B.1.2. of the work programme, is in progress.

Progress and Results

1. Determination of basic charge parameters (B.1.)

The basic parameters characterising the reference cutting charge have been defined:

- base width 50 mm, charge depth 50 mm;
- copper liner: thickness 1.5 mm, angle 100 degree;
- high explosive: Octol;
- aluminium confinement;
- central initiation.

A sketch of the charge is shown in fig.1.

2. Numerical two-dimensional studies

By means of the Eulerian processor of the hydrodynamic computer code PISCES 2D [1], the processes of collapse and jet formation have been simulated for six different configurations of the cutting charge. The charges studied differ from the reference one in: plane detonation wave and lateral initiation (wave shaping); liner thickness; liner angle; charge depth. In fig.2 three contour plots of pressure and density at three different times are reported (reference charge).

The higher jet velocities have been obtained in the case of wave shaping and in the case of a thin liner.

3. Studies with an hybrid technique

To obtain more detailed information on the characteristics of the formed laminar jet, the PISCES 2D hydrocode was also used, linked with the analytical code OTOSC1, following the procedure described in [2] and [3]. The configurations analysed differ from the reference one (X0) in: liner thickness 1.0 mm (X1A) and 2.0 mm (X1B) [X0=1.5mm]; charge depth 30 mm (X2A) and 50 mm (X2B)

[X0=40mm]; liner angle 80 degree (X3A) and 120 degree (X3B); [X0=100degree]; lateral initiation (wave shaping) (X4A) [X0=central initiation].

Results:

- smaller liner thickness: higher jet velocity, but lower jet mass;
- larger charge depth: higher jet velocity and mass, but higher undesidered side effects;
- smaller liner angle: higher jet velocity, but lower jet mass;
- wave shaping gives an increase of both jet mass and velocity, but requires very high precision during manufacturing processes.

4. Definition of test configurations

In order to avoid as far as possible ambiguities arising from superimposition of different effects, it is planned to test charges which differ from the reference one, called C0, in a parameter only: liner thickness 1.0 mm (C1A) and 2.0 mm (C1B); liner angle 80 degree (C2A) and 120 degree (C2B); charge depth 40 mm (C3); wave shaper (C4); multiple detonators (C5).

5. Manufacture of reference charges (B.1.2.)

The manufacture of two batches of four reference charges each has been started. The following manufacturing processes are under investigation:

- a) the aluminium confinement is machined to a final thickness of 4 mm;
- b) the confinement is obtained by cold forging of a 1.5mm-thick aluminium sheet.

This work is presently in progress.

References

- /1/ M. Trigg, S. Hancock and H. Hancock, "PISCES 2D ELK User's Manual", (version 4), Physics International Company, San Leandro, California, USA, October 1985.
- /2/ G. Pezzica, G. Pazienza and G.M. Vignolo, "Numerical Modeling Of Shaped Charges With Wave-Shapers", 10th Int. Sym. on Ballistics, San Diego, California, 27-29 October 1987.
- /3/ G. Pezzica and G. Pazienza, "Shaped Charges: Discussion About Jet Formation And Jet Penetration Under Static And Dynamic Conditions", 11th Int. Sym. on Ballistics, Bruxelles, Belgium, 9-11 May 1989.

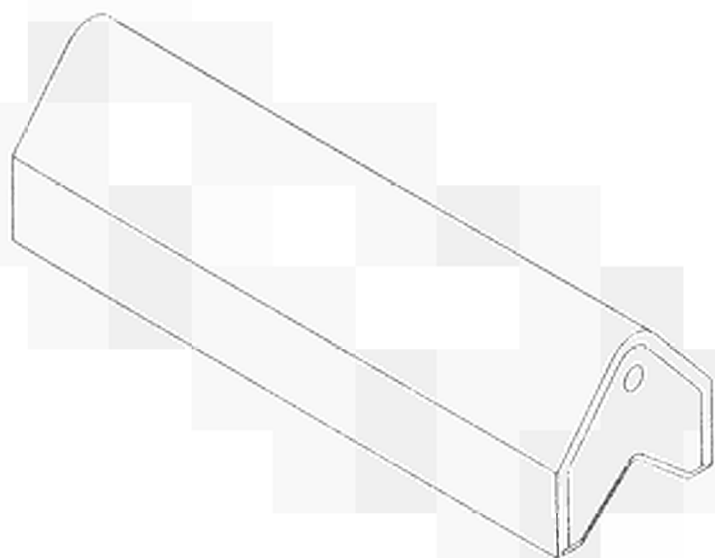
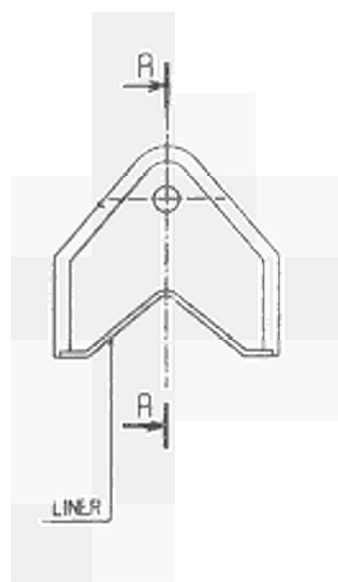
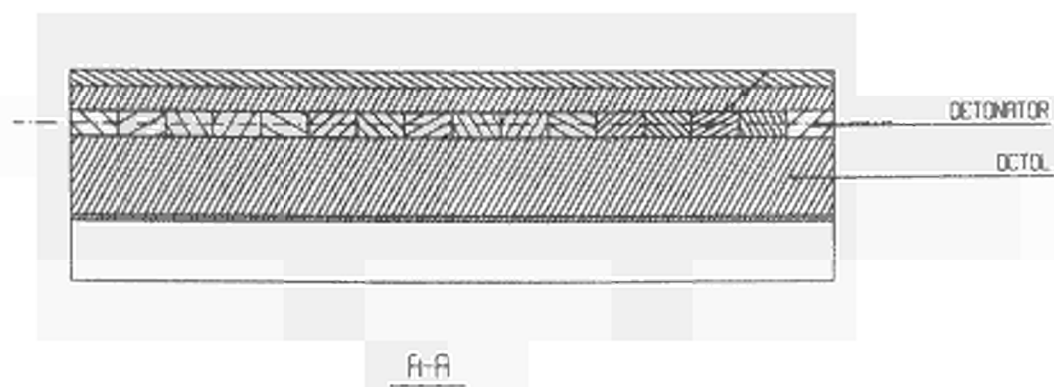

Figure 1: reference cutting charge

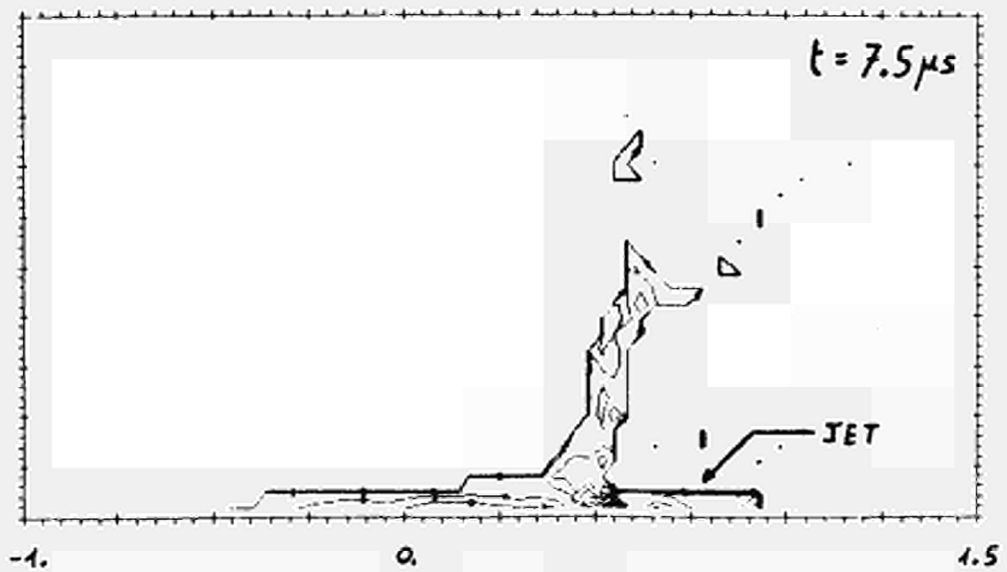
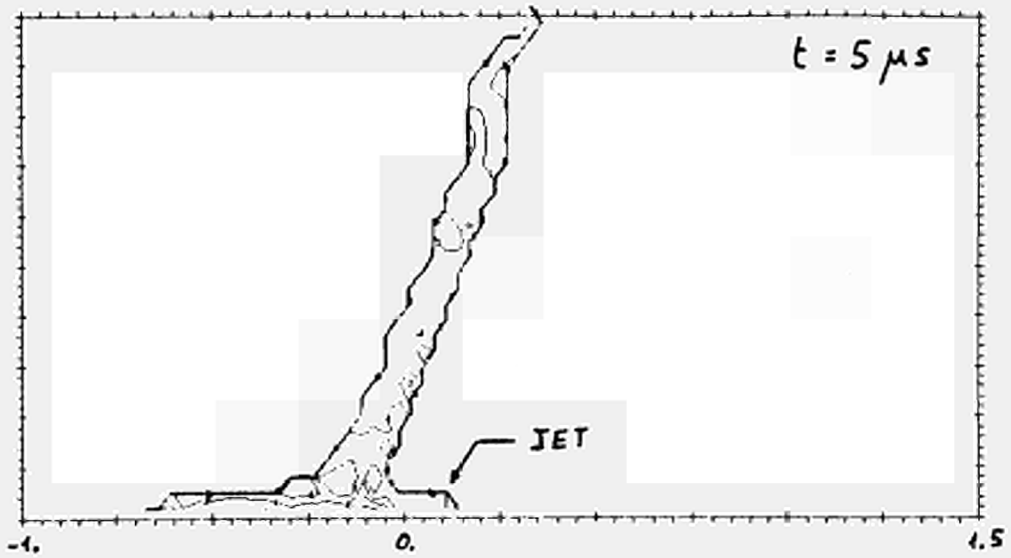
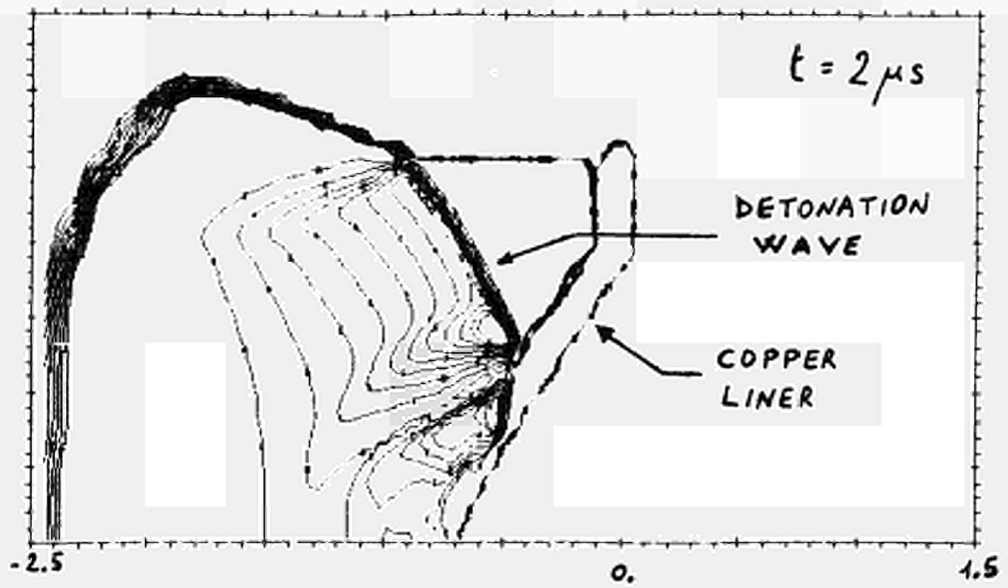

Figure 2: reference configuration, contour plots of pressure and density (PISCES 2D code)

3.4. EVALUATION OF THE SEGMENTATION BY VARIOUS CUTTING TECHNIQUES (PLASMA TORCH, ARC SAW, CIRCULAR DISC, ETC.)

Contractors: CEA Valrhô, CEA-Sac
Contract No.: FI2D-0013
Work Period: October 1990 - June 1992
Coordinator: Ch LORIN, CEA/DCC/UDIN
Phone: 33/66 79 63 04 Fax: 33/66 79 64 32

A. OBJECTIVE AND SCOPE

The project relates to industrial-scale testing in air of various relevant cutting tools. Its originality is a comparison between tools in the same normalised conditions of use.

The main purpose of this work is a comparison of different cutting techniques for the same working conditions in order to determine the real cutting time, to improve the knowledge of the cutting tools, and to evaluate the generated secondary wastes, cost aspects and the radiological impact.

The work requires an inactive testing cell, as well as appropriate materials and tools: the cell, located in an inactive testing station at CEA/Fontenay-aux-Roses, is an airtight room in which it is possible to work in a controlled atmosphere. Carbon and stainless steel plates with thicknesses of 10, 30 and 50 (or 60) mm with exactly known composition of the radioelements will be cut; the cutting tools which will be used are arc air, plasma torch, arc saw, circular disc and alternative saw.

Meetings will be arranged with partners after each tool test in order to improve their execution; therefore, the tests are carried out one after another. It is envisaged to cooperate in specific areas with the Universität Hannover and with the French industry.

The potential benefits of these tests are the protection and security of workers, a decrease of the volume of waste effluents and a better use of the tools themselves for future decommissioning work.

B. WORK PROGRAMME

- B.1. Preparation of the testing cell (CEA-Sac)**
- B.2. Cutting under inactive conditions with selected tools and materials (CEA-Valrhô)**
- B.3. Cutting under simulated radioactive conditions (CEA-Valrhô)**
- B.4. Secondary waste analysis after each specific cut (CEA-Sac)**
- B.5. Final evaluation of the cutting techniques assessed, including the cost of the basis tool, the associated logistic, the consumable part, the radiation exposure to workers and research of relevant radionuclides in the cell (All).**

C. Progress of work and obtained results

Summary

The facility where the cuts take place, the analytical techniques and the test specifications are described. In the first tests, made by automated mode, mild and stainless steel plates with thickness of 10 and 30 mm were cut by grinder and reciprocating saw.

The first results show that the sedimented dross is the major part of the secondary emissions (up to 99,9 % for alternative saw), the wear of the tool is not negligible (grinder disc), the cutting speed and the tool driving are very influent parameters in the production of secondary emissions and mainly on aerosol one.

Progress and Results

1. Preparation of the testing cell, analytical techniques and tests specifications (B1)

The test takes place in a 32 m³ cell composed of modular stainless steel panels. A cutting rig, motorized in XY, on which the tool and the workpiece can be adjusted, is located inside this cell (figure 1).

The workpiece is weighed before and after cutting. The sedimented dross is collected under the workpiece (figure 2) and weighed.

The attached slag is broken off manually or machined off and weighed.

The mass of particles on the walls of the cell is deduced from sample surfaces (figure 1) on which swabbing is carried out and weighed. The eventual wear of the tool is determined by weighing.

Nozzles are installed in the exhaust pipe connected to the cell to allow isokinetic sampling into (figure 3) :

- filters of 130 mm diameter and filters of 47 mm diameter upstream and downstream of the electrostatic filter.

- an inertial and diffusional spectrometer (SDI 2001).

Total aerosol mass concentrations are measured by filtration and weighing. The fiberglass filters used are 130 mm and 47 mm diameters and have a collection efficiency of more than 99.99 % for particles of size superior to 0.3 micron.

The SDI 2001 is an apparatus which combines an Andersen impactor with a diffusion battery containing beds of spheres of specified sizes. It allows determination of the size distribution of particles between 0.075 and 15 microns.

The flowrate in the exhaust duct, that can be adjusted by a valve located downstream the fan, is determined from the indication of a calibrated orifice plate.

The different steps of the tests (preparation of the sampling filters, of the cell and of the exhaust duct, cutting ventilation, sampling, swabbing, collection of secondary wastes, weighing) are repetitive and carried out with great care.

2. Results for cutting under inactive conditions (B.2)

Grinder - Stainless steel

The sedimented dross represents the major part of the solid secondary emissions, about 92 % for e (thickness) = 10 mm and 97 % for e = 30 mm.

The mass loss of the workpiece is in relation with the ratio of the thickness but the disk is worn more rapidly for e = 30 mm than for e = 10 mm (506 g/m for e = 30 mm and 54 g/m for e = 10 mm).

When the thickness is multiplied by 3, the aerosol mass is multiplied by 2 (6.4 g/m and 12.6 g/m) but the cutting speed is a very influent parameter on aerosol production and need a special study.

The size distribution of aerosols is bimodal with the main mode around 7 microns.

Reciprocating saw

The sedimented dross represents the major part of solid secondary emissions, up to 99.9 %. There is no attached slag. In one test, we have emphasized that the particles mass on the walls of the cell, the aerosols and the wear of the blade were more important than in similar tests, because the blade was blocked with an angle of 90° with the workpiece and thus resulted in a local raise of temperature.

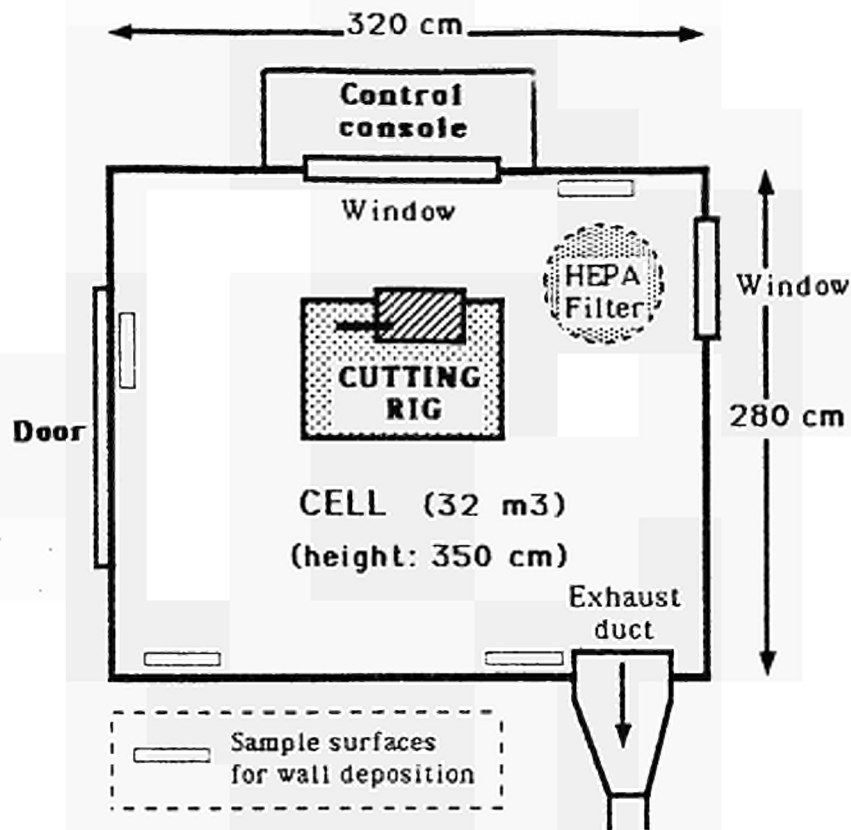

Figure 1 : Schematic view of cutting cell

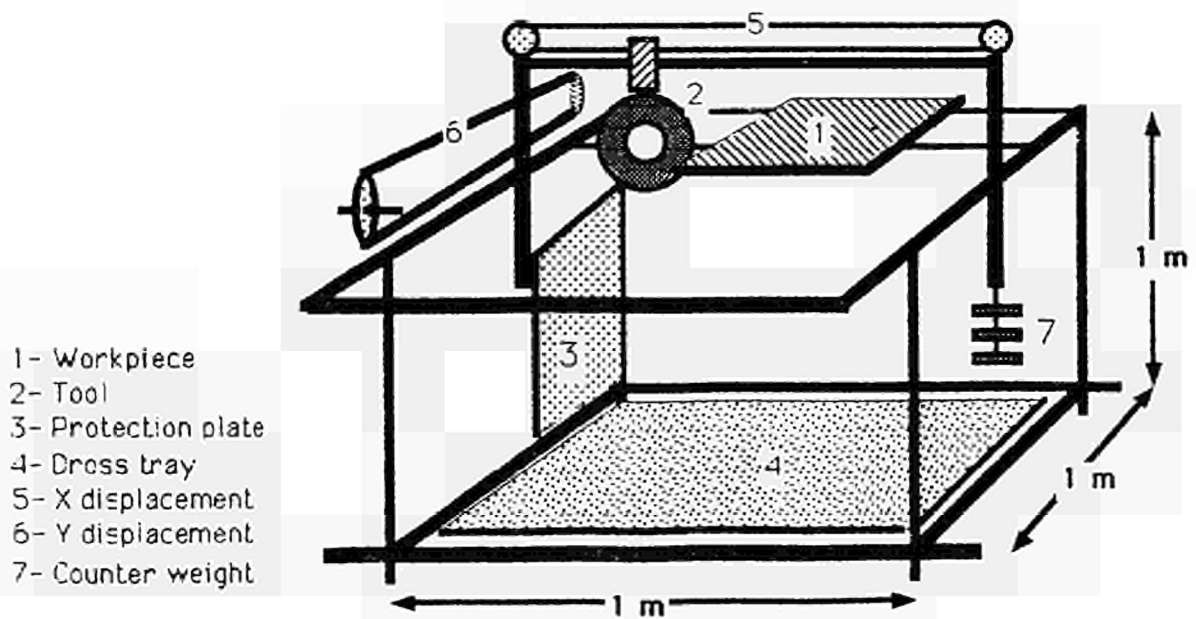

Figure 2 : Schematic view of cutting rig

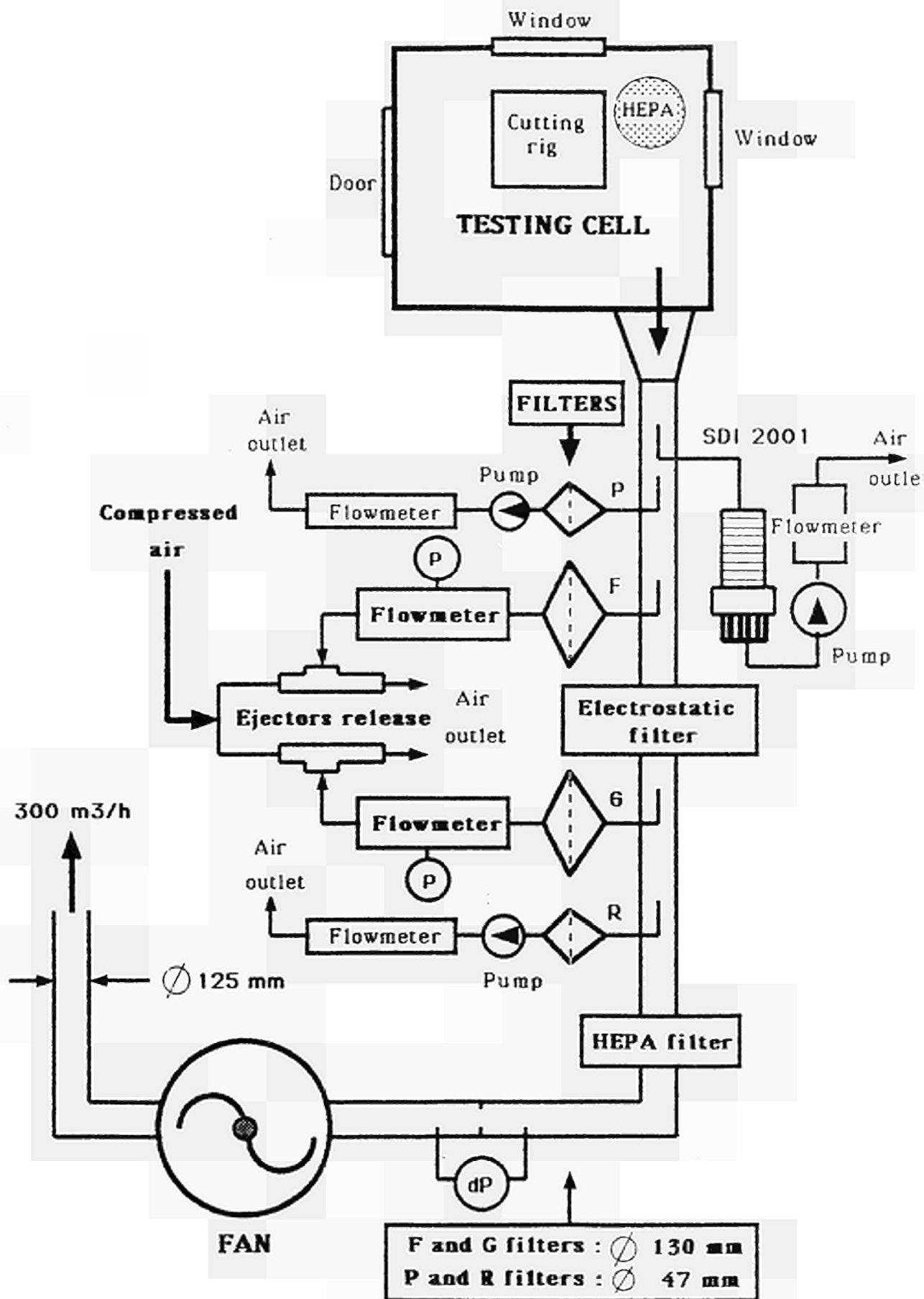

Figure 3 : Schematic view of the ventilation system and associated samplings

3.5. UNDERWATER THERMAL CUTTING TECHNIQUES AND ASSOCIATED REMOTE-CONTROLLED MANIPULATOR SYSTEMS

Contractors: CEA-Cad, UH-IW, RWTHA, CEA-Sac
Contract No.: FI2D-0019
Work Period: July 1990 - December 1993
Coordinator: R LEAUTIER, CEA Cad, SST/SMP/GP
Phone: 33/42 25 73 08 Fax: 33/42 25 32 62

A. OBJECTIVE AND SCOPE

This project aims at improving underwater thermal cutting techniques and their remote control. The main objectives are to cut greater thicknesses and improve the safety of operation, e.g. assess harmful by-products, protect workers, assist the operator during operations.

So far, underwater thermal cutting of steel has been achieved up to 70 mm thickness. This project has the objective of achieving cutting up to 200 mm. Sensors and associated systems studied in laboratory will be applied in a semi-industrial installation.

The work involves an experimental investigation in the laboratory of each contractor followed by real-case applications under non-radioactive and radioactive conditions in the former Pegase reactor in Cadarache.

The project is a follow-up of work performed in the 1984-88 EC programme (contracts FI1D-0037, -0007 and -0039).

B. WORK PROGRAMME

B.1. Preliminary tasks (CEA-Cad)

- B.1.1. Detailed requirements and objectives of the project
- B.1.2. List of parameters and ranges to be studied
- B.1.3. Specifications of sub-systems

B.2. Development of the plasma torch and adaptation of the moving device (CEA-Cad)

- B.2.1. Improvement of the performances of the plasma torch
- B.2.2. Adaptation of the moving device
- B.2.3. Integration of the sensors into the torch handling system
- B.2.4. Cutting tests with measurement of effluents

B.3. Development of other tools (UH-IW)

- B.3.1. Optimisation of cutting parameters of plasma saw and consumable electrode
- B.3.2. Control systems usable with the manipulator of CEA-Cad
- B.3.3. Cutting tests with measurement of effluents

B.4. Development of control systems for sensor-controlled piloting of the handling system for the tools and the process parameters (RWTHA)

- B.4.1. Improvement and application of inductive sensors
- B.4.2. Process control and piloting of the tool handling system
- B.4.3. Interfacing between the sensor system and the handling control system
- B.4.4. Function testing in the laboratory

B.5. Preparation of radioactive samples taken from nuclear installations (all)

B.6. Final tests in Cadarache (all)

- B.6.1. Transport of the systems to Cadarache and installation on the manipulator
- B.6.2. Cutting tests on non-radioactive representative models
- B.6.3. Tests with samples prepared under B.5.

B.7. Final evaluation and recommendations (all)

C . PROGRESS OF WORK AND OBTAINED RESULTS

Summary of main issues

The work carried out in 1990, was connected with four main aims, in relation to the topic of work programme packages B.1, B.2, B.3, B.4, B.5.

. Firstly the distribution of functions between the different partners involved in the contract, the definition of the models for final tests, the specifications and main features of the necessary equipment were drawn up.

. Secondly the following working steps have begun :

Development of the plasma torch, adaptation of the moving device and test tank.

Development of the plasma saw, the consumable electrode tool and the control systems.

Development of control systems for sensor-controlled piloting of the handling system for the tools and the process parameters.

Preparation of radioactive samples.

Progress and results

1 . Preliminary tasks (B.1)

With regards to the technical annex of the CEC contract, the distribution of functions and tasks was defined in close cooperation with CEA Cadarache, IW Hanover, RWTH Aachen, CEA Saclay, in order to specify the main features of the necessary equipment.

The models to cut at Cadarache during final tests come from the Rapsodie reactor, which is in its decommissioning phase.

These models represent the least accessible points encountered in the reactor and some of them are shown in Figures 1 to 3.

As regards each model and the conformity to the cutting capability, we have made a selection of adapted tools for each model to cut.

Also associated to the above, the control of the motor system was defined with a selection of manual, semi-automatic or automatic control for each displacement axis and rotational movement.

The distribution of the control system is given in Figure 4.

Regarding the requirements for final tests, specifications of the sensor system for measurement and distance guidance, detection of holes in the work-piece, recognition of edges, were drawn up.

Concerning the generated cutting effluents, specifications for ventilation and filtration, measurements of aerosols, suspended particles, sedimented dross, attached slag, gas, were defined.

2 . Development of the plasma torch, adaptation of the moving device and test tank (B.2)

As regards the accuracies required to position and move the tools in these thickness conditions, we have to design a new manipulator and motor system.

This design phase has begun.

Furthermore the dimensions and shape chosen for final tests have led to the realization of a tank greater than our current test tank ; its designing has also begun.

A first investigation concerning the improvement of the capability of the nuclearized torch has been made.

3 . Development of the plasma saw, the consumable electrode tool and the control systems (B.3)

The first cutting tests will take place in a water basin with a volume of 18 m³ and a working area of 4 m x 2 m x 1.5 m (l x b x h). To qualify the tools and control systems for cutting in 5 m water depth tests will then be done in a basin which is 5 m in diameter and 5.25 m in height.

The consumable electrode tool :

Stainless steel tubes (88.9 x 1.5 mm) were successfully cut with the consumable electrode torch in a water depth of 5 m with a cutting speed of 400 mm/min and a current of 900 A using a stainless steel consumable wire with a diameter of 3.2 mm. The equipment for these cuts was a 100 kW welding rectifier which supplies a max. current of 2500 A at 40 v.

With the same power source 100 mm thick stainless plates could be cut with a cutting speed of 135 mm/min and a current of 2500 A using a mild steel consumable wire of 4mm in diameter. Referring to these results it may be necessary to operate two rectifiers in parallel in order to reach greater section thicknesses.

A sketch of the consumable electrode tool is shown in figure 5.

The plasma saw :

A sketch of the working principle of the plasma saw torch is shown in figure 6. Its main characteristic is the slim rod with the nozzle positioned rectangular at the tip. This rod immerses into the kerf during the cutting process as shown in figure 6. To obtain a kerf wide enough for it to dip in, the torch is rotated by approximately 60° around its vertical axis at the top and the bottom dead center of the up and down motion. The motoring device required for the plasma torch is being designed.

The equipment for the plasma saw is a 30 kW power source. A mixture of argon and nitrogen is used as plasma gas.

The control systems :

Promising results were achieved using a small CCD-Camera (12V DC) during preliminary cutting tests with a plasma torch and the consumable electrode tool. The dimensions of this camera are 50 mm x 60 mm x 60 mm (l x b x h) and it is equipped with a selfadjusting iris. For underwater use it is mounted in a special water-resistant housing.

As there occurred some difficulties in positioning the tool to the workpiece in all three dimensions with the camera in a fixed position in relation to the torch holder it seems to be advisable to use a second camera. This camera may either be fixed to the torch holder or be manually movable around the torch.

4 . Development of control systems for sensor-controlled piloting of the handling system for the tools and the process parameters (B.4)

Inductive sensor :

Based upon tests made in the former Decommissioning project an inductive sensor for distance measurement was selected and proved the function of the device in the new application.

Investigations about the possibility of hole detection beared some problems because the diameter of the used sensor was too great. Therefore a sensor with a smaller diameter will be tested.

Process control :

The cutting process can be divided into several parts of automatic, semi-automatic and manual tasks under control of the operator. These tasks are :

Location of the torch to the starting point of the cutting trajectory by manual or semi-automatic operation, definition of cutting direction or ending point ;

Select all power source parameters such as cutting current and gas flow by manual operation ;

Select manipulator parameters such as distance between torch and workpiece (respectively between sensor and workpiece) and travel speed (manual operation) ;

Detection of the edge of the workpiece (automatic operation of manipulator control unit and inductive sensor) ;

Automatic teach-in operation for recognition of workpiece exact position, workpiece orientation and workpiece thickness along the cutting trajectory ;

Automatic return of the torch to the starting edge of the workpiece in correct cutting distance ;

Switch on plasma gas, cooling water and pilot arc (manual operation) ;

Start the cutting arc at the workpiece, wait until workpiece thickness has been burned through and start motion (manual) ;

Motion will be controlled automatically, the operator has the possibility of an on-line correction of process parameters and of interruption of the process in case of malfunction or reaching the end of the trajectory ;

Turn off all systems, i.e. gas flow and plasma power source (manual operation).

Interfacing :

For the purposes of controlling the complete unit a microcomputer system will be used. Figure 7 shows the schematic structure of the control system and interfaces.

The following interfaces will be developed for the control of the different subsystems :

Interface for control of motors

Analog interface for the inductive sensor

Analog or digital interface for the IW ultrasonic sensor

User interface for control of the whole system

5 . Preparation of radioactive samples (B.5)

Radioactive samples that come from dismantling of nuclear installations are welcome.

These radioactive samples have to be :

Free of α emitters ;

If possible, with no loose contamination ;

Within a radioactive range i.e. not too contaminated (or irradiated) in order to have no radioprotection problems and no liquid waste treatment but sufficiently contaminated (or irradiated) in order to get significative radioactive measurements for the different secondary emissions.

Thus, for example, according to previous experiments within the second programme of the CEC about decommissioning of nuclear installations, it would be necessary to have a surface contamination between 10^2 and 10^5 Bq. cm^{-2} for ^{137}Cs .

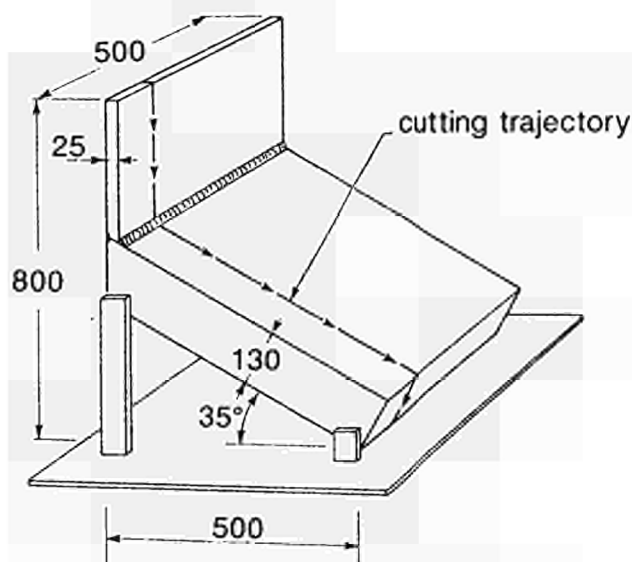

Figure 1: Vessel bottom head which is with variable thickness and requires change of tool orientation during cutting

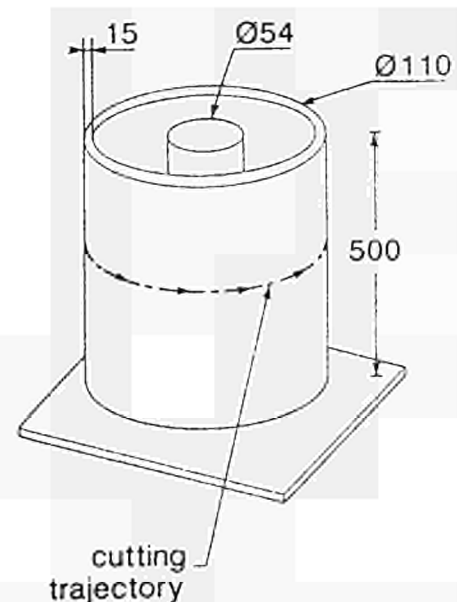

Figure 2: Stud and spacer to cut to separate the diaphragm from the vessel bottom head

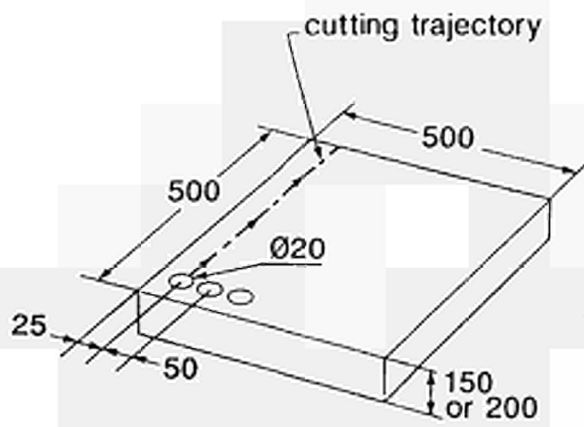

Figure 3: Diagrid

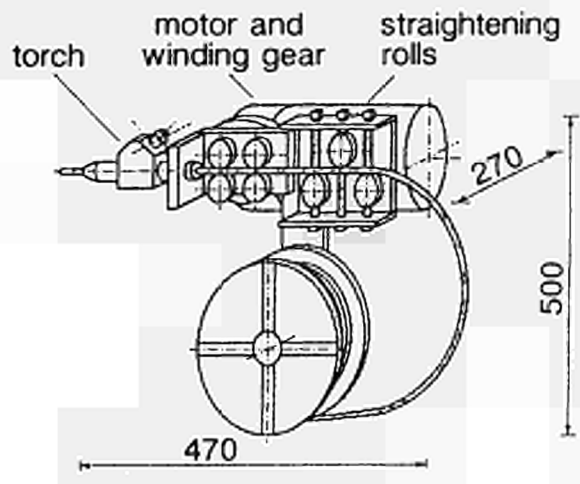

Figure 5: Sketch of the prototype consumable electrode tool

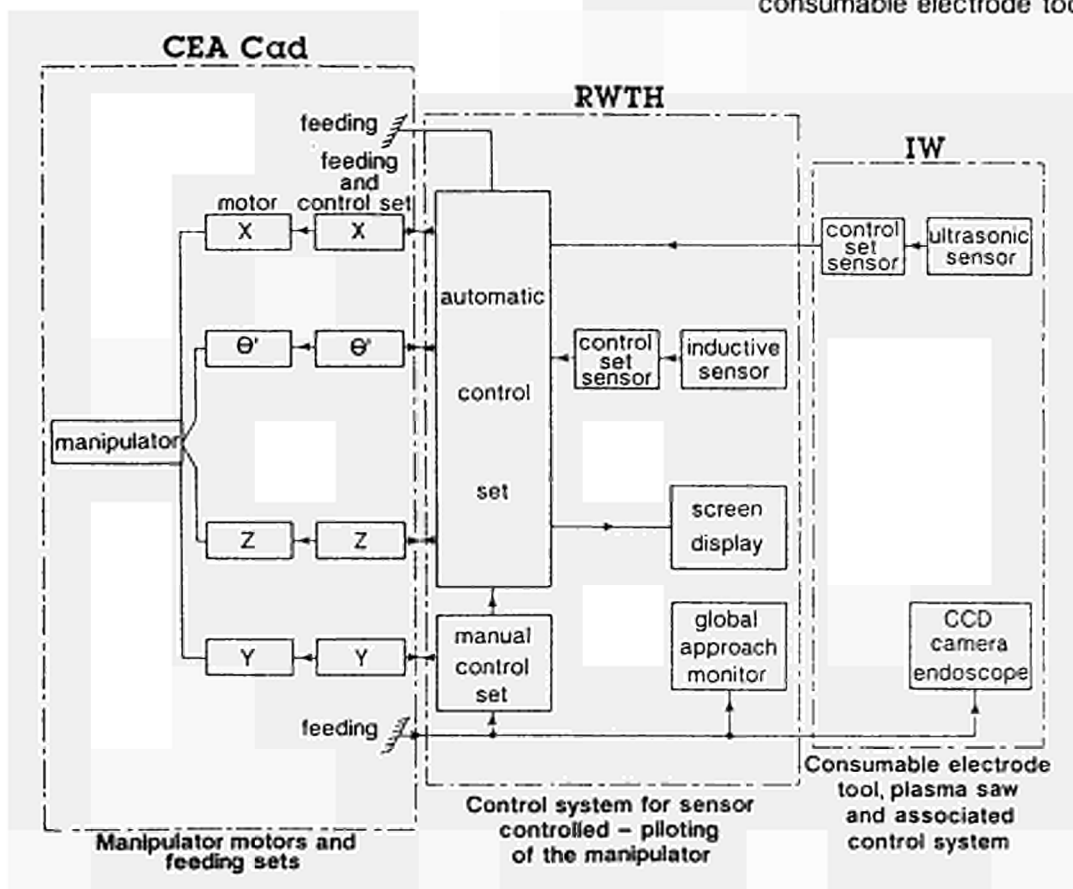

Figure 4: Distribution of the control system

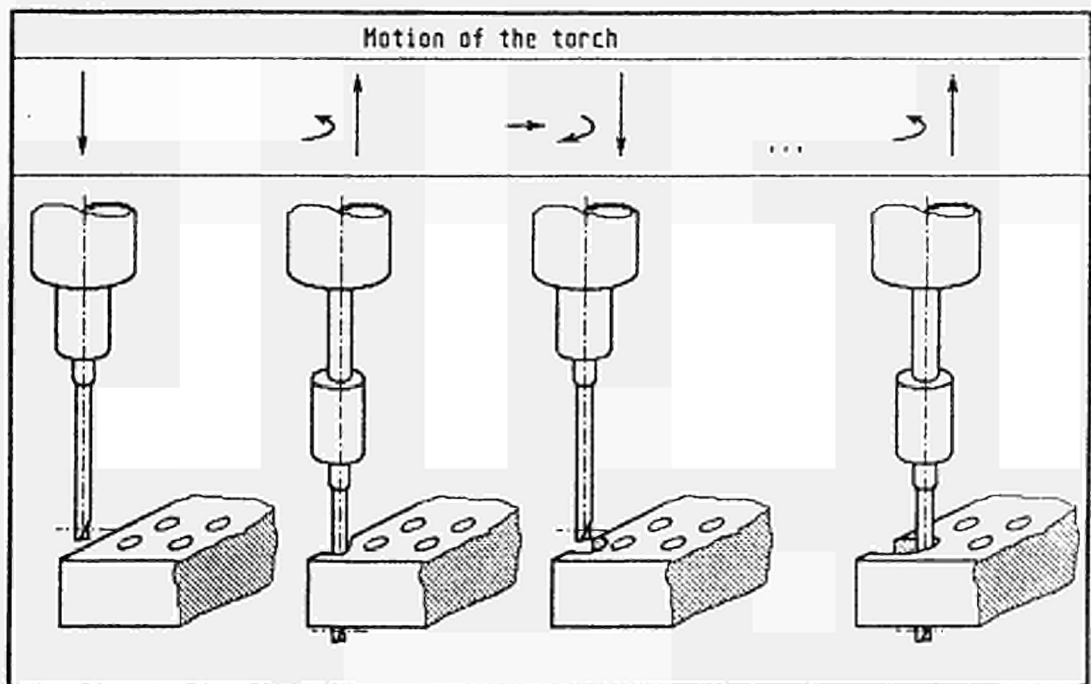

Figure 6: Working principle of the plasma saw

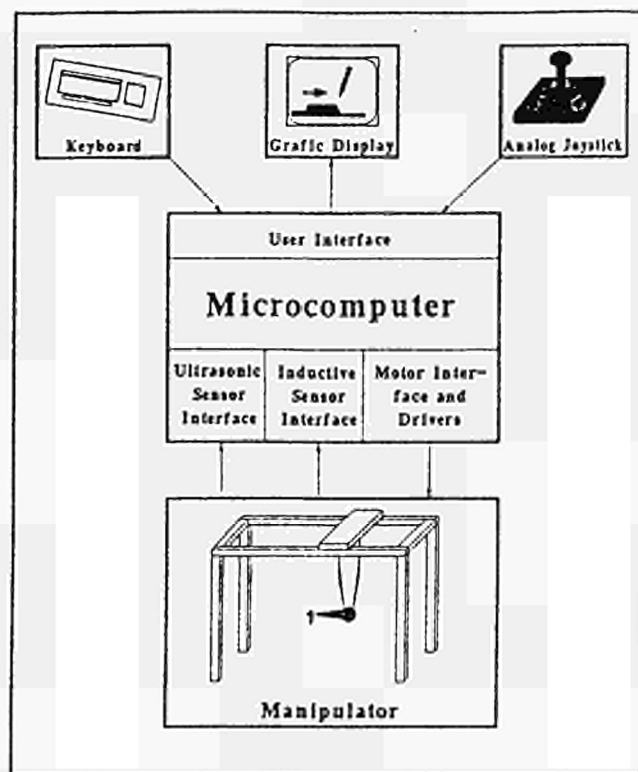

Figure 7: Structure of the control systems and interfaces

3.6. DEVELOPMENT OF A PLASMA ARC TORCH AND CONTROL/MONITORING TECHNIQUE FOR THE INTERNAL CUTTING OF SMALL BORE PIPEWORK

Contractors: AEA Wind
Contract No.: FI2D-0026
Work Period: July 1990 - June 1993
Project Manager: M T CROSS, AEA Wind.
Phone: 44/9467/72432 Fax: 44/9467/28023

A. OBJECTIVE AND SCOPE

During decommissioning of nuclear facilities, small bore pipework needs to be cut remotely up to distances of 10m with access through the top of the pile cap. Often, due to the close packing of the pipework, the cutting operation must be performed internally through the bore of the tube. In the absence of direct viewing and manual access, there is a requirement to develop techniques for the cutting process and methods for monitoring and remotely controlling its operation and ensuring its effectiveness. The plasma torch process has been selected as the cutting method based on economic considerations and on its reliability and effectiveness in remote and manual operations.

The objective of the project is to develop:

- techniques based on non-contact sensors which can monitor and remotely control the progress and effectiveness of the cutting process;
- a small plasma torch capable of being inserted in the bore of < 50 mm internal diameter pipework with remote deployment (up to 10 m distance) under automatic control;
- the deployment system which can be located on the pile cap, positioned above each pipe in turn and lowered to a predetermined depth to perform a complete circumferential severance of the tube in one pass.

The work will include cutting trials of the complete system in a full-size mock-up of a reactor gas manifold.

The AEA Northern Research Laboratories will take into account the experience gained elsewhere and particularly at the "Institut für Werkstoffkunde der Universität Hannover" on plasma arc torch cutting and its control/monitoring.

B. WORK PROGRAMME

- B.1. Literature survey to find the most suitable plasma cutting combination for this application.**
- B.2. Torch adaptation for remote deployment and automatically controlled rotation**
- B.3. Examination of the cutting parameters on representative pipework.**
- B.4. Control system developments; monitoring technique and feedback system will be designed, developed and interfaced for automatic control.**
- B.5. Preliminary testing of the deployment system in small-size mock-up**
 - B.5.1. To test the workability of the remote deployment system.
 - B.5.2. To check the feedback control system under remote operation conditions.
 - B.5.3. To optimise the equipment to commercial standards.
- B.6. Testing of the deployment system in full-size mock-up to evaluate the optimised system in a representative decommissioning environment.**
- B.7. Final evaluation including specific data on costs and radiological impact on work force and working area, working time and secondary waste arisings.**

C. Progress of Work and Obtained Results

Summary of main issues

Significant progress has been attained in the early phases of this contract following finalisation during September 1990. The Literature Review part of the work (Task B1) has now been completed and has suggested a range of sensors which could be adapted for control of the cutting process. An air plasma torch is considered to be the most suitable technology for a compact torch to be deployed in a small bore tube geometry. Work has now started on the development of an acoustic sensing monitor for controlling the progress of cutting and, of all the sensing technologies reviewed, we consider this technique to offer the best prospect for future development (Task B4).

Some preliminary testing has now been carried out using a prototype compact plasma torch to sever a range of mock-up tube sections. These tests have been encouraging and, on this basis, a multi-axis deployment rig has been designed for placement of the torch at distances up to 10 m. Tenders have now been invited for construction of the rig.

Progress and Results

1. Literature survey (Task B1)

The Literature Survey has included a systematic search through an Engineering Indexes Computer Database, containing details of Journal Articles published worldwide. Reference to Plasma Arc Cutting were found 172 times, going back to 1976 and the titles and synopses of these articles were obtained. From this information, a number were selected as being relevant to the task in hand and copies of the full article obtained. These have been grouped into the following areas.

- (a) Articles discussing the general principles and merits of Plasma Arc Cutting. Fifteen articles of this nature have been collected.
- (b) Articles which discuss the use of Plasma Arc Cutting in Decommissioning Projects. Plasma Arc Cutting has been used at Three Mile Island and on the Japanese JPDR. A total of nine articles come into this category, which together with the proceedings of the CEC Conference on the Decommissioning of Nuclear Installations in October 1989 and our own experience at Windscale have provided valuable background information.
- (c) Articles which focus on a particular aspect of the Plasma Arc Cutting process which could form the basis of a control mechanism. These include such topics as voltage calibration, kerf formation etc. Of particular interest has been a series of articles by scientists at several Russian Research Institutes. Their research seems to have concentrated on the physical processes taking place during cutting, particularly in the arc forming chamber. Eighteen such articles have been collected.

A Patent Survey has also been undertaken. In a similar exercise to the Literature Survey, a search of Patent Indexes was performed, covering worldwide patents going back to 1963. A total of 458 references to Plasma Arc Cutting were found. The search field was then restricted to the Control and Monitoring of the Plasma Arc Cutting process. A total of 110 references were found and a list of these obtained. This list is quite extensive and a good indication of previous work in this area.

Reports produced by RWTH Aachen and the "Institut für Werkstoffkunde" at "Universität Hannover" under previous CEC contracts have been received.

Part of the purpose of the Literature Survey has been to determine the types of Plasma Sets and Torches which are commercially available, to

enable selection of a Plasma Set suitable for this application. Considering the need to adapt a torch for operation within a small bore pipe, an air plasma torch has been identified as the most suitable for modification and has now been purchased and preliminary tests performed (see Section 2).

The Literature and Patent surveys have suggested that the following parameters are available for monitoring and control purposes: current, voltage, gas flow, stand-off distance, cutting speed, material thickness. The output current and voltage of the plasma set can be monitored by circuitry connected within the set. Similarly the Gas Flow rate can be measured by a flowmeter adjacent to the plasma set. Types of sensors which have previously been employed for the parameters measured external to the set and adjacent to the cut are inductive, ultrasonic, tactile and optical. Restrictions on the type of external sensors that may be employed are determined by the nature of the environment, particularly the excessive heat generated by the plasma arc, and the physical space available for sensors to be positioned internally within the pipework being cut.

However, it has been realised that there is a distinct difference in audible sound emitted by the cutting process when penetration of the material is achieved. It is intended to investigate this effect further as a possible parameter that could be monitored and incorporated into a control system (see Section 4). It is necessary to ensure that the commercial plasma set purchased will be suitable for adaptation for the incorporation of control equipment. It is envisaged that the standard parameters of plasma set output current and voltage will be monitored and so there should be sufficient space within the control unit for the insertion of extra component boards.

2. Torch Adaptation Design Study (Task B2)

A design study has been undertaken to determine the method for attaching, rotating, suspending and positioning the torch for accurate location inside the small bore pipework. Initially, different types of plasma cutting systems were assessed to determine a suitable plasma unit with a torch head capable of modification.

The survey of equipment has shown that gas plasma torches are too bulky to fit down the inside of pipes of bore less than 50 mm. This is because they require a higher operating current than air plasma torches to cut material of the same thickness which means their torches need to be larger. As an example, a typical air plasma set requires 30 Amps to cut through 6 mm mild steel, whilst a gas plasma set requires 100 Amps. An air plasma unit has therefore been selected as being suitable for cutting through small bore pipework. A specific torch has been chosen for its simplicity and compact design and has been modified in order to permit access to small bore pipework.

The design study has revealed that the position of the torch head will have to be made adjustable in order to maintain a fixed distance between the nozzle tip and the pipe surface and also to allow the same torch to be used for different bore pipework.

A solution to this problem is being examined based on the use of a spring loaded coupling between the torch head and the rest of the deployment system which forces the torch nozzle to make contact with the inside wall of the tube during the cutting operation thus ensuring a constant stand-off distance.

Following a detailed analysis of the requirements for a remote deployment system, a plasma torch deployment rig capable of four degrees of freedom in positioning the torch (x, y, z, θ) has been designed. The rig consists of a supporting framework constructed in conjunction with linear

slides which will be used to support and position a suspended plasma torch over the WAGR 'hot box' (hot gas manifold). Prior to active deployment, a series of optimisation trials to prove the workability/remote handling of this equipment is planned (Tasks B5, B6). Tenders have now been issued for construction of this deployment rig.

3. Examination of Cutting Parameters (Task B3)

The plasma set which has been selected is manufactured by Econocut and has a fixed output current of 30 Amps. Initial cutting tests have been carried out on single lengths of tube, both insulated and non-insulated. A rotary stepping motor has been used to vary the cutting speed, and an optimum cutting speed of three quarters of a revolution per second selected. It was discovered that increasing the speed beyond this point meant that full penetration of the insulated type of tube was not achieved at the point where the insulation overlapped.

Beyond this, no further investigation has yet been done on the tolerance of the system to variations in the cutting parameters, or an assessment made of nozzle wear and damage. This is scheduled for later on in the programme.

4. Control System (Task B4)

The requirements of the control system have been identified. These include:-

- (a) optimising the operation of the plasma cutter, by monitoring and controlling the cutting parameters, so as to reduce dross production, fume and spatter
- (b) ensuring the effectiveness of cut
- (c) detecting nozzle obstruction or damage

In addition to the monitoring techniques considered by RWTH Aachen under contract FIID-0039, some investigation using acoustic monitoring and non-contact sensors has been made. This has been carried out on a Plasma Arc Cutting facility at AEA Springfields.

The results so far appear encouraging and frequency spectrum analysis of the monitored signals suggest specific frequencies exist when satisfactory penetration of the metal is achieved with severe attenuation of these frequencies when penetration is lost.

5. Preliminary testing of the deployment system in a small-size mock-up (Task B5)

An experimental prototype of a small section of the WAGR hot box (gas manifold) containing tubing for test purposes has been designed. No deployment trials have yet been conducted.

3.7. DEVELOPMENT OF A STEEL CABLE TO CUT HIGHLY REINFORCED CONCRETE WITH MINIMISED WATER CONSUMPTION

Contractor: Diamond Service
Contract No.: FI2D-0027
Work Period: September 1990 - May 1992
Project Manager: A BOSELLI
Phone: 39/523/822 447 Fax: 39/523/822 630

A. OBJECTIVE AND SCOPE

The project is aimed at the development of a steel cable charged with diamond pearls with particular cutting qualities, considerable mechanical resistance and minimum consumption of water or other cooling mixtures. The cable should be particularly suitable for cutting highly reinforced concrete structures of nuclear installations. The main objective is the control of secondary waste generation (cooling and severed concrete) during the cutting operations. The cuts can be carried out at various distances from operator to structure and therefore offer considerable security and protection of work force. The cutting time and the derived radiation exposure to operators will be evaluated on a uncontaminated concrete structure.

The contractor will carry out cuts on concrete structures of a USSR nuclear plant; the obtained results will be compared with those obtained within the framework of this project.

B. WORK PROGRAMME

- B.1. Development of a high resistance diamond pearl**
- B.2. Development of suitable materials for the cable vulcanisation**
- B.3. Preparation of the test mock-up and of a representative concrete block**
- B.4. Selection and improvement of a suitable steel cable**
- B.5. Assembling of cable components (light steel cable, diamond pearls, springs and spacers)**
- B.6. Cutting tests on non-contaminated concrete structures**
- B.7. Final evaluation, taking into account cable consumption, costs of the technique, cooling water consumption, secondary waste arisings, radiation exposure, and a comparison with the cutting work carried out in the USSR.**

C. PROGRESS OF WORK AND OBTAINED RESULTS

Summary of main issues

During the period from September 90 to December 90, some Diamond pearls with various physical and mechanical features were manufactured. Furthermore, a highly reinforced concrete structure on which the cutting tests will be carried out has been built. During this first period, no considerable problems were encountered.

Progress and results

1. Development of a high-resistance diamond pearl (B.1.)

Before starting this programme, the diamond pearls for cutting concrete were made of synthetic diamond 50/60 Mesh or 40/50 Mesh grading. For this new project, a synthetic diamond 30/40 Mesh type SDA 100 S was used. It has the advantage over the previous one of a very high resistance both to mechanical impact and thermal shock, thus allowing the increase of the cutting speed.

The diamond powder has been mixed with particular bonds having the twofold function of being anti-abrasive and resistant to possible rise of the temperature due to poor water cooling during the cutting operations.

2. Preparation of the test mock-up and of a representative concrete block (B.3.)

For the cutting tests, a highly reinforced concrete structure with appropriate grading and strength (RBK 350) was built up (figure 1). The iron-cement ratio is Kg. 1850/c.m. Information about the cutting results will be given in the next progress report.

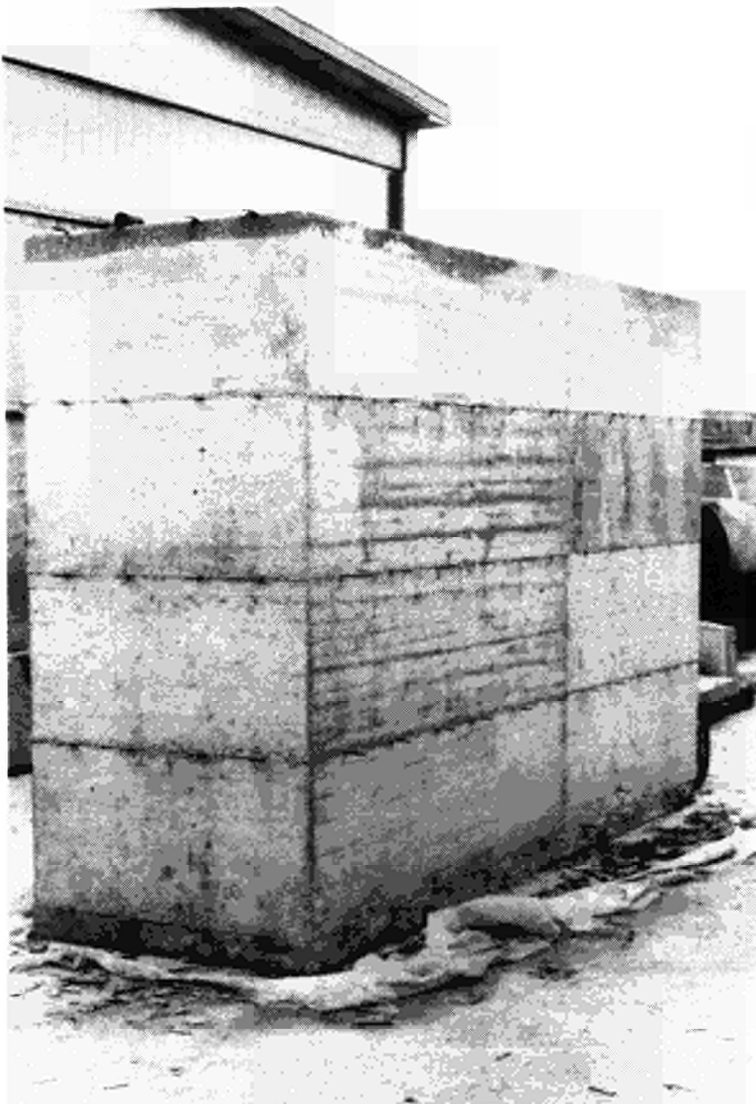

Figure 1: Concrete test mock-up.

3.8 ASSESSMENT OF STATE-OF-THE-ART CO LASER TECHNOLOGY AS AN IMPROVED DISMANTLING TOOL

Contractors: AEA Culh., DLR Stuttgart
Contract No.: FI2D-0028
Work Period: September 1990 - August 1992
Coordinator: J H MEGAW, AEA Culham
Phone: 44/235/46 42 15 Fax: 44/235/46 41 38

A. OBJECTIVE AND SCOPE

The main objective of this project is to carry out a laboratory-scale experimental investigation of the capabilities and potential advantages of carbon monoxide (CO) lasers, compared with carbon dioxide (CO₂) lasers. Previous studies on CO₂ lasers for decommissioning indicate that they can operate as elegant and flexible tools, but there are limitations with regard to cutting performance, and a need for articulated mirror-based beam delivery systems. The present project is motivated by: reported Japanese results indicating CO laser cutting performance significantly superior to that of CO₂; and the potential for use of optical fibre beam delivery at the shorter wavelength (5 µm cf 10.6 µm).

The partner organisations (which are currently engaged in developing CO lasers in the power range up to approximately 1 kW) will carry out complementary investigations, using CO and CO₂ beams, on steels, concrete and graphite concerning: the nature of the beam-workpiece interaction and how it differs at the two wavelengths; assessment of the respective cutting capabilities. It is expected that the work will: provide the sole European source of such information; enable quantification of possible technical and economic advantages of CO lasers for decommissioning; provide information on the parallel Japanese programme (where it is reported that CO lasers of ≥ 20 kW are under development); make recommendations on a strategy regarding possible future use of CO lasers for decommissioning and commercial exploitation thereof.

The responsible partners for work on structural steel and graphite and for work on stainless steel and concrete will be AEA and DLR, respectively.

B. WORK PROGRAMME

- B.1. Assessment of beam-workpiece interaction for CO laser, and comparisons with CO₂ laser (All)**
- B.2. Assessment of CO laser cutting capabilities and comparisons with CO₂ laser (All)**
- B.3. Final evaluation showing quantified differences in materials-processing capabilities of the two lasers, specific data on costs, secondary waste produced and radiological impact on workforce and working area (All)**

C. PROGRESS OF WORK

Summary of main issues

The opening four months of the project has been a period of scheduling and preparation, in which there has been as yet a very low commitment of resources, but which nevertheless contained the first joint meeting of the collaborators where the experimental programme has been discussed in detail, agreed and planned. Notwithstanding a somewhat delayed start to experimentation, progress is still fully consistent with the planned overall timespan of 15 months for Task B.1.

Planning

Beam-workpiece interaction for CO laser, and comparisons with CO₂ laser

The following conclusions and plans emerged from the first Project Meeting at DLR. Initial experiments will concentrate on the role of the coupling of the CO and CO₂ beams to the kerf wall, and on the role of plasma formation. As regards the former, analysis of laser-processed samples will feature careful characterisation of the kerf walls and in particular the inclination of its leading face as determined in a suddenly-stopped cut. A small amount of theoretical work will be carried out with the aim of modelling the energy deposition in the kerf as a function of depth, since this should enable prediction of the cut shape. The calculation will be based on estimation of Fresnel absorption for the relevant local angle of incidence, where this will vary due to beam divergence and kerf inclination. As regards the role of plasma in the coupling of beam energy, the methodology will employ what is expected to be a sensitive method for quantification of plasma effects (and their variation at the two laser wavelengths) viz: use of an ambient gas mixture of helium and argon. These respectively resist and promote plasma formation (ionisation potentials 24.6 eV and 15.8 eV) so that variation of the relative proportions will provide a controlled method to study plasma initiation and plasma absorption.

3.9. CUTTING OF CO₂ PRIMARY CIRCUIT PIPES OF G2/G3 REACTORS USING EXPLOSIVE CHARGES

Contractors: CEA Valrhô, COMEX, EPC
Contract No.: FI2D-0036
Work Period: September 1990 - April 1992
Coordinator: Ch LORIN, CEA/DCC/UDIN
Phone: 33/66 79 63 04 Fax: 33/66 79 64 32

A. OBJECTIVE AND SCOPE

The project is part of the dismantling of the primary cooling circuit (CO₂) of the G2/G3 gas-graphite reactors, composed of valves, blowers and tubes (diameters 800, 1200 and 1600 mm with respective thicknesses of 10, 15 and 20 mm), using explosive charges. It includes technical studies, experimental investigations and tests at industrial scale, carried out under real radioactive conditions.

The innovation of this project is the use of shock waves, produced by the explosive charges, to remove the inside contaminated oxide layer of the tubes.

The use of explosive charges seems beneficial because allowing to cut remotely large activated or contaminated items under improved protection and safety conditions for workers and with a minimum of secondary waste arisings.

The data output will mainly be related to:

- the necessary time to carry out dismantling operations using explosive charges and their respective costs,
- the safety and radiation exposure of personnel involved in the operations,
- the effectiveness of shock waves for decontamination purposes.

B. WORK PROGRAMME

B.1. Assessment of basic cutting parameters

- B.1.1. Definition of cutting power of dihedral-shaped charges (EPC)
- B.1.2. Establishment of the agreement files (All)
- B.1.3. Preliminary test series on flat steel plates (EPC)
- B.1.4. Calculation of the minimum quantity of explosive for each thickness (EPC)

B.2. Pre-test series with bounded steel samples (simulating tube sections) (EPC)

B.3. Definition of pyrotechnic devices (EPC, COMEX)

B.4. Detailed engineering study of validation tests

- B.4.1. General assessment of the test conditions (COMEX, EPC).
- B.4.2. Definition and design of auxiliary equipment required during cutting operations (COMEX, EPC)
- B.4.3. Selection of representative items to be cut (All)

B.5. Validation tests on G2/G3 tubes

- B.5.1. Definition of test procedure as needed for agreement by authority (CEA)
- B.5.2. Preparation of the test area (All)
- B.5.3. Validation tests: 27 cutting operations on 800, 1200 and 1600 diameter tubes) (All)

B.6. Final evaluation of all relevant data collected, e.g. specific data on costs, radioactive job doses, working time and secondary waste arisings (All).

C. Progress of work and obtained results

Summary of main issues

The three partners, CEA/UDIN, COMEX and NITROBICKFORD have already met three times since early November. The main directive lines of work have been defined. Three types of pipes have been chosen to be treated in the zone number 4 of G2 reactor, at the level of the CO2 turbo-pump n°1. This area has to be isolated before beginning the operations, but it will be possible only during 1992. The contamination and irradiation levels in the involved pipes and in the working area are known. The confining will be supplied by a depression inside the pipes. It is expected to be reinforced at the time of the external explosion.

An appropriate cutting device exploding around the pipe has been designed for each size.

Decontaminating and cutting tests will continue in 1991. They should allow to record stresses during an explosion and to evaluate the efficiency of decontaminating by explosive means. The study of the environment of pipes, and the elaboration of safety files have been initiated.

Progress and Results

1. Definition of the optimal device (B.1, B.2, B.3)

1.1. Presentation

The cutting device is a plastic ring supporting a circular hollow-shaped charge. The ring is divided into sectors which are filled up with an explosive (NITROROC). The internal side is made of a dihedral concave metallic part.

Three tests series of 27, 9 and 15 shots have been pursued to define :

- the metal, angle and thickness of the dihedral part,
- the most efficient kind of NITROROC : liquid or gel,
- the width, height and "stand-off" of the ring section.

1.2 Results (for a thickness of steel of 15 mm)

Dihedral part :	metal	Copper (Cu)
	angle	90°
	thickness	1.5 mm
Section of the ring :	width	20 mm
	height	24 mm
	"stand off"	10 mm
Minimal charges for flat steel plates :		
	thickness	10 mm needs 310 g/m of Nitroroc
	"	20 mm needs 520 g/m of Nitroroc
	"	25 mm needs 1100 g/m of Nitroroc

The liquid Nitroroc gives slightly better results than the gel. Although copper is more efficient for the dihedral part, steel will probably be used. Indeed copper is a poison for the re-melting of cut steel. See figures 1 and 2.

2. Trial zone and pipes (B.4.)

2.1. Selection

An experimental area has been specified in the zone number 4 of G2 reactor, at the level of the CO2 turbo-pump number 1.

This area contains samples of the following primary pipes, which have been chosen for the tests.

Diameter (mm)	Thickness (mm)
1600	25
1200	19
800	13

There are both aspiration and exhaust pipes, hanging at different heights.

2.2. Radiology of the trial zone

This zone is classified in the category "2B" (0.75 to 2.5 mrad/h i.e. 7.5 to 25 μ Gy/h, with risk of contamination) and will become "2C" during the trials (effective contamination). The zone is easily accessible for preliminary studies.

The confining system will be based on a dynamic depression inside the pipes : i.e. aspiration and filtration (electrostatic filters and very high efficiency filters).

2.3. Contamination and irradiation of selected pipes

Here contamination consists in a graphite layer on the lower part inside the pipes. It can be oily in the exhaust pipes. Contamination is due to Co60 (95 %) and Cs137 (5%) and is valued at 100 to 2000 Bq/cm². The irradiation in contact is valued at 0.5 to 10 mrad/h (5 to 100 μ Gy/h) with hot points at 10 to 50 mrad/h (100 to 500 μ Gy/h). The irradiation at a distance of 1 meter is below 1 mrad/h (10 μ Gy/h).

Contamination will be measured before and after cutting so as to value the efficiency of the method for decontaminating. It will be particularly paid attention to the scattering of aerosols at the time of explosions.

Pre-tests will be pursued at Saint-Martin-de-Crau to observe several parameters.

3. Conclusion

At the end of 1990, the zone and the conditions for the industrial phase have been specified. A cutting device using explosives has been designed. The work continues with the study of the environmental pipes and their supports. Tests will also be pursued to value the stresses and pressures during an explosion.

The first test in radioactive zone will take place in March 1991 on an isolated pipe with contamination. The partners and especially COMEX and CEA, will soon have to elaborate the safety files.

The industrial phase is expected to begin in 1992, after the dismantling of surrounding zones.

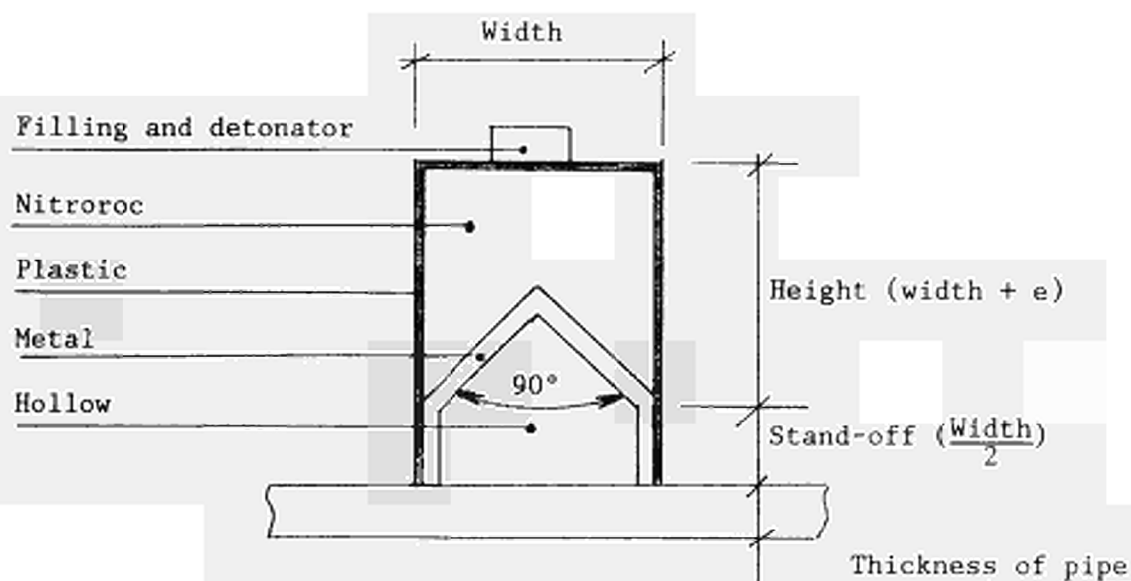

Figure 1 : RING SECTION

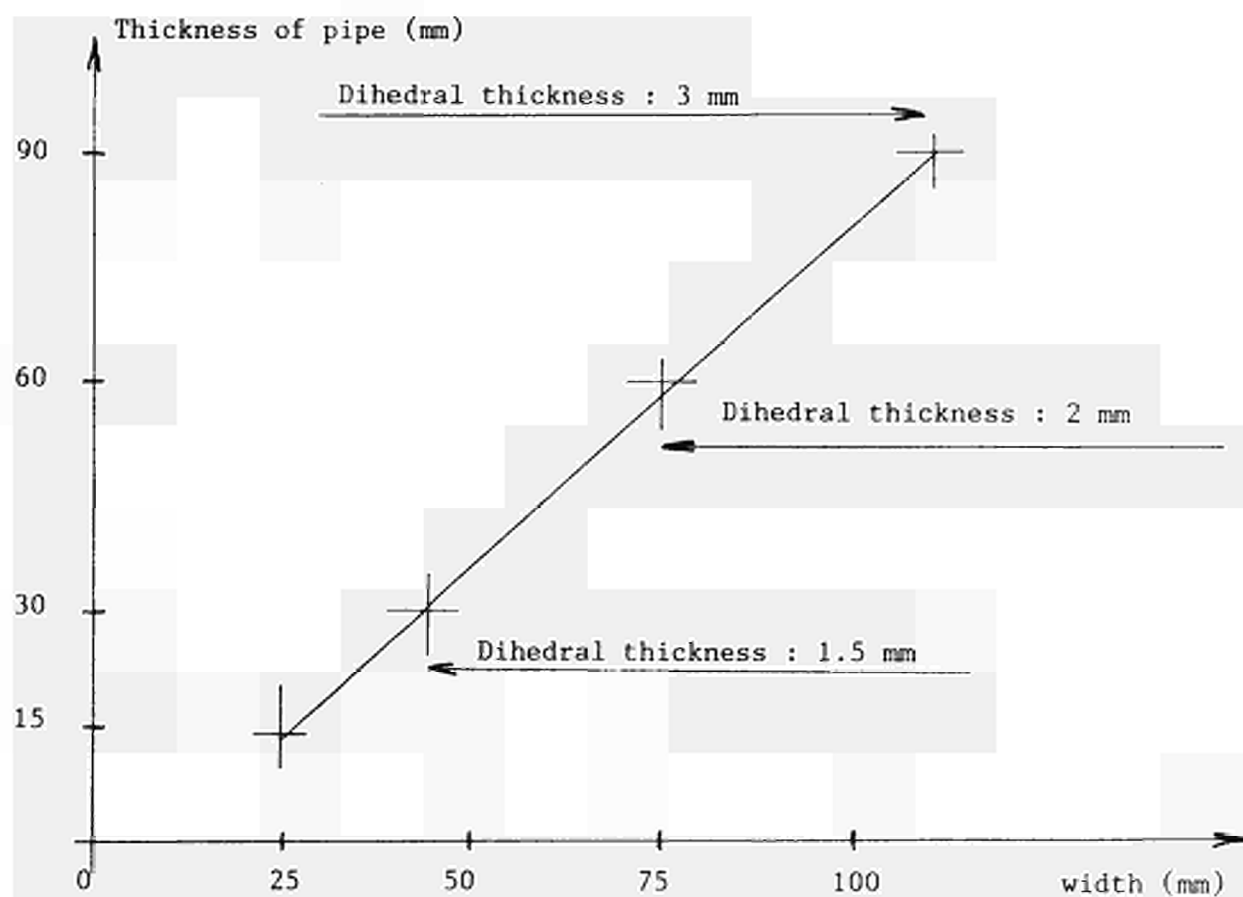

Figure 2 : EXTRAPOLATION

4. AREA No. 4: TREATMENT OF SPECIFIC WASTE MATERIALS: STEEL, CONCRETE AND GRAPHITE

A. Objective

In the dismantling of nuclear installations, large amounts of radioactive metal, concrete and - in the case of gas-cooled reactors - graphite will arise. This waste must be suitably conditioned for disposal or recycling. The area has been strictly delimited to preclude overlapping with the Community research programme on radioactive waste management.

B. Subjects of the research performed under the previous programmes (1979-88)

Research work performed mainly related to:

- the treatment of dismantled material such as steel, copper and brass by melting with a view to its possible recycling/reuse; the reduction of its volume; its decontamination (e.g. elimination of actinides);
- development and assessment of techniques for coating metal and concrete parts in order to immobilise surface contamination; assessment of treatment techniques for radioactive concrete;
- comparative assessment of various modes of treatment and disposal of radioactive graphite; development of a conditioning technique for radioactive graphite bricks for shallow land disposal.

In all these investigations, due attention has been paid to the necessity of adapting treatment techniques to final waste destinations.

C. Programme 1989 to 1993

Melting of very low-level radioactive steel scrap from Light Water Reactor components, to produce new nuclear components, is already becoming industrial practice and is not expected to need further research. Further work is required, however, in relation to steel scrap originating from other types of nuclear installation, e.g. alpha-contaminated material, and non-ferrous scrap.

Further development is also needed for concrete and graphite waste, i.e.:

- volume reduction of contaminated/activated concrete;
- metallic coating of graphite parts by ionic deposition to fix radionuclides;
- recycling of the reinforcement steel in concrete.

D. Programme implementation

At the end of 1990, four research contracts relating to Area No. 4 were at the stage of execution and one contract was at the stage of negotiation.

4.1. DEVELOPMENT OF A PROCESS FOR VOLUME REDUCTION OF CONTAMINATED/ACTIVATED CONCRETE WASTE INCLUDING PILOT-SCALE TESTING WITH ACTIVE WASTE

Contractors: KEMA, Taywood
Contract No.: FI2D-0015
Work Period: July 1990 - December 1993
Coordinator: H A W CORNELISSEN, KEMA, Arnhem
Phone: 31/85/56 61 04 Fax: 31/85/51 54 56

A. OBJECTIVE AND SCOPE

This work concerns the development of a semi-technical scale test installation for separation of concrete constituents. As only a relatively thin layer of concrete structures will be contaminated or activated, the proposed process consists in a further volume reduction of the material to dispose off by separation of the radioactive constituents (cementstone) from the supposed non-radioactive part (aggregates) of this removed concrete cover.

The material that will be conditioned originates from decommissioning activities at the Kahl nuclear power plant.

The research programme could be useful for developing an industrial-scale manufacturing process. Furthermore, the experience gained in this field by Taywood (CEC contract FI1D-0042) will be applied to solidification.

B. WORK PROGRAMME

- B.1. Selection of a separation technique: determined by the importance of the activation/contamination of the concrete constituents. (KEMA)**
- B.2. Determination of process variables for the conceptual design of the test installation.**
(KEMA)
- B.3. Design of a small-scale transportable test installation.** (KEMA)
- B.4. Construction of the test installation.** (KEMA)
- B.5. Testing and optimisation of the installation with non-radioactive concrete.** (KEMA)
- B.6. Verification with radioactive concrete.** (KEMA)
- B.7. Immobilisation and solidification of concrete debris.** (Taywood)
- B.8. Evaluation of the results with respect to equipment, costs, released activity etc.** (KEMA)

C. Progress of work and obtained results

Summary of main issues

In order to develop a test installation for volume reduction of contaminated/activated concrete, first the basic decision was made with respect to the separation technique. Based on laboratory tests it was concluded that separation by heating followed by milling was most favourable. This finding was supported by a feasibility study for the design of installations. More information can be found in Ref./1/.

Progress and results

1. Separation by cooling versus separation by heating (B.1)

From laboratory tests at KEMA it was concluded that heating of concrete followed by milling results in separation of concrete in cementstone and aggregates (> 1 mm). By TNO a research programme was executed with respect to separation by cooling of concrete in liquid nitrogen.

An important step for the development of a test installation is the decision whether it will be based on cooling or on heating. Therefore verification tests were performed with respect to separation by a thermal shock in liquid nitrogen. The results were compared with results obtained after a thermal treatment at 650 °C. In both cases the thermal shock was followed by milling for 4 hours. The results are expressed as the separation efficiency (Ed):

$$Ed = As/Ao$$

in which As is amount of separated material (≤ 1 mm) in a given grain size range, and Ao the corresponding original amount of fine material in the concrete.

In table I the results are presented for crushed portland cement concretes with maximum grain size of 31.5 mm (OPC 31.5).

It can be seen that separation (of material ≤ 1 mm) is much more effective after heating than after cooling.

Table I: Heating versus cooling for OPC 31.5 concretes

thermal treatment	separation efficiency (%)
<u>heating (4h; 650 °C)</u>	
test 1	82
test 2	84
test 3	74
<u>cooling (liquid N₂)</u>	
test 1 (5 min; 5.1*)	34
test 2 (12 min; 5.1)	45
test 3 (12 min; 0.8)	37

* concrete humidity (%)

Tests were also performed with portland cement concretes with maximum grain size of 4 mm (OPC 4). In order to improve milling, in some cases 16-25 mm aggregate particles were added to the mill, followed by another 1 hour milling. The results are expressed in table II.

Table II: Heating versus cooling for OPC 4 concretes

thermal treatment	separation efficiency	
	4h milling (%)	after 1 h additional (%)
heating (4h; 650 °C)	61	71
cooling (12 min; 5.1*)	36	36

* concrete humidity (%)

It can be seen that also for low maximum grain size concrete separation by heating gives better results. The addition of aggregate particles to the mill is only effective after heating.

From the laboratory tests it could be concluded that a pre-treatment of heating before milling has to be preferred to a thermal shock in liquid nitrogen.

2. Determination of process variables (B.2)

Based on separation by heating various important variables were studied.

2.1. Effect of heating temperature

Two concrete cubes were heated for four hours, one at 750 °C the other at 650 °C, and then milled for 8 hours. The results are given in table III. As shown, no significant differences were found.

Table III: The effect of oven temperature

cement type	temperature (%)	separation efficiency (%)
OPC 31.5	750	93
PBC 31.5	650	88

2.2. Effect of heating period

Three concrete cubes were heated at 750 °C. One for 8 hours, one for 4 hours and one for 2 hours and subsequently milled for 8 hours. The results are given in table IV. No significant differences could be observed.

Table IV: The effect of heating period

cement type	period (h)	separation efficiency (%)
OPC 31.5	8	79
OPC 31.5	4	93
PBC 31.5	2	91

2.3. Effect of milling period

The effect of the milling period was investigated by milling for 2, 4, 6 and 8 hours respectively. Every 2 hours the sieve curve of the specimen was determined.

It was found that there are only minor effects. Additional tests were performed with PBC 31.5 concretes heated for 4 hours at 650 °C and then milled for 5, 10, 20, 30, 60, 120 and 180 minutes. After each time step the separation efficiency was calculated for the sieve results.

Milling for 1-2 hours proved to give good results under the given test conditions.

2.4. Effect of dust on milling

Two cubes of OPC 31.5 were treated according to the same procedure as described before (heated at 750 °C for 8 hours). One specimen was milled for 8 hours without dust removal, whereas in the case of the other specimen the dust was removed every 2 hours followed by charge sieving.

The results indicate that dust removal leads to a slightly improved milling efficiency. Moreover in the case of milling without dust, a raise of efficiency as a function of milling period was observed.

3. Conceptual design (B.2)

Besides the physical aspects of separation and the resulting separation efficiencies, the consequences for the design of an installation have to be considered. Therefore global conceptual designs were made based on cooling as well as on heating. Basically four set-ups were analyzed:

- heating followed by water cooling
- heating followed by natural cooling in air
- cooling in liquid nitrogen
- parallel system of heating and cooling.

For economical and technical reasons the option based on heating followed by natural cooling in air was selected. This installation contains the following process steps:

- crushing
- sieving over 1 mm
- heating in an electrical furnace
- cooling in air
- milling
- sieving over 1 mm
- conditioning of dust; reuse of sand and gravel.

A schematic view of the set-up for the installation is shown in Figure 1.

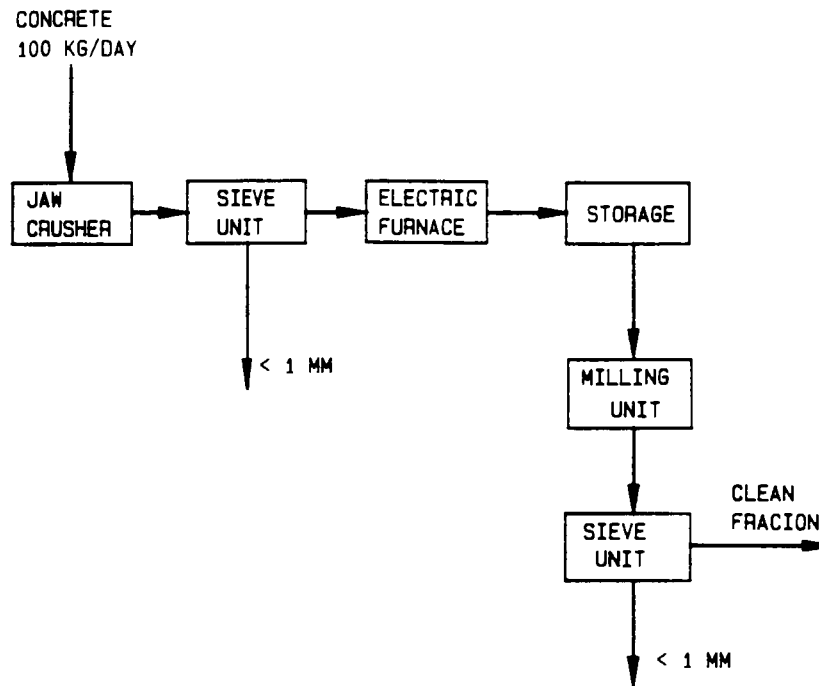

Figure 1: Set-up of the test-installation for separation of concrete

References

- /1/ Cornelissen, H A W, Test-installation for separation of contaminated/activated concrete; progress report 1 (period 900701-901231) - selection of separation technique - determination of process variables for the design. KEMA-report 10140-CBP 91-6, January 4, 1991.

4.2. INVESTIGATIONS ON RECYCLING OF RADIOACTIVE NON-FERROUS ALUMINIUM AND COPPER BY MELTING PROCESS

Contractors: Siemens-KWU, SG
Contract No.: FI2D-0037
Work Period: December 1990 - December 1993
Coordinator: K.H. GRÄBENER, Siemens-KWU
Phone: 49/69/807 36 45 Fax: 49/69/807 20 66

A. OBJECTIVE AND SCOPE

The research work aims principally at developing a method to refine contaminated Al and Cu scrap to a product that enables unrestricted reuse in conventional industrial process.

Parameters such as heating rate, temperature, slag former, surrounding atmosphere will be varied to get optimum conditions for decontamination by melting.

The behaviour of the most relevant isotopes will be investigated and the possibility of melt decontamination on Al and Cu will be examined. For the treatment of Al, co-operation with CIEMAT, Madrid, will be established (contract No. FI2D-0023).

The organic coatings on various Cu items represent a special handicap. Investigations will be made on how the radioactivity is distributed between metal and coatings, whether the separation prior to melting is necessary or not and how harmful gaseous effluents can be managed.

In preceding works, the melting technique was already assessed for steel (contracts Nos. FI1D-0044 and FI1D-0016).

B. WORK PROGRAMME

- B.1. Arrangement between CIEMAT, Madrid/Siemens-SG to co-operate in aluminium melting.**
- B.2. Installation of an inductively heated furnace with exhaust system. (SG)**
- B.3. Procurement of representative contaminated Al and Cu samples. (Siemens)**
- B.4. Treatment of Cu. (SG)**
 - B.4.1. Investigations on metal coating separation and gamma-nuclide distribution.
 - B.4.2. Basic melting experiments with observation of radiation and contamination of workers and working area.
 - B.4.3. Supplementary melting experiments with varying melting conditions.
 - B.4.4. Determination of radionuclide distribution in slag, metal, dust and coating.
- B.5. Laboratory-scale melting experiments with Al. (Siemens)**
 - B.5.1. Optimisation of melting conditions.
 - B.5.2. Determination of radionuclide distribution.
 - B.5.3. Investigations on recycling of the salt melts.
- B.6. Melting of Al in an industrial furnace. (SG)**
- B.7. Derivation of specific data on costs, radioactive job doses, working time and secondary waste arising from the above items. (all)**

C. Progress of Work and Obtained Results

Summary

The work was started in Dec. 1990 with a program arrangement between CIEMAT/Spain and Siemens-SG /Germany to co-operate in aluminium melting

The following conclusions have been adopted:

- Task B.5 of SIEMENS proposal and task B.3 of CIEMAT proposal have the same aim.
- Go ahead with co-operation on laboratory melting experiments with Al scraps, to avoid duplication of tests.
- SIEMENS and CIEMAT will receive information from one to another about the characteristics, composition and radionuclides content of the aluminium scraps to be melted.
- Referring to the timetables of the proposals subtasks, B.5.1 and B.5.2 of SIEMENS will be finished before 1992 and subtasks B.3.2, B.3.3 and B.3.4 of CIEMAT will start in 1992.
- As to the preceding, the activities of SIEMENS will be complemented by CIEMAT to avoid duplication of tests.
- There will be mutual information between SIEMENS and CIEMAT.
- There will be regular meetings between SIEMENS and CIEMAT to discuss the different aspects of co-operation.
- Each one of the participants will have to take over costs of their activities.

4.3. RECYCLING OF ACTIVATED/CONTAMINATED REINFORCEMENT METAL IN CONCRETE

Contractors Bureau A +
Contract No.: FI1D-0021
Work Period: September 1990 - February 1992
Coordinator: H H KOOLEN, Bureau A +
Phone: 31/47/50 17 400 Fax: 31/47/50 33 264

A. OBJECTIVE AND SCOPE

A large part of activated or contaminated steel and copper arising from decommissioning of nuclear installations could be recycled, as aggregate or reinforcement in concrete for new nuclear installations. The object of the study is:

- 1) choosing the type, amount and form of the metals to be used;
- 2) analysing the possible process to transform the metal into smaller particles and producing high grade concrete;
- 3) finding out the possible applications of different concrete qualities within the field of nuclear applications.

The first part will be a literature review, the second part will consist in laboratory experiments with non-radioactive metals, and the third part will be a desk study.

During the study, specific data about the process costs will be estimated. This research programme has a strong relationship with the melting technique developed by SGR (FI1D-0016 and 0059) and could have interactions with the separation technique studies by TNO/KEMA (FI1D-0068).

B. WORK PROGRAMME

- B.1. Literature study on metal waste types, quantities and activation/contamination levels in order to select potential processes for waste transformation.**
- B.2. Conduction of a specific test programme on combinations of different metals and metal forms with concrete and mortars.**
- B.3. Evaluation of the results and survey of possible applications.**

C. Progress of work and obtained results

Summary of main issues

In this first part of our program we have started with the desk-top study about the quality and amounts of the contaminated steel set free during nuclear plant decommissioning. From several sources (mainly Progress Reports from the European Community, 1987 International Decommissioning Symposium, Pittsburgh and the 1988 symposium Decommissioning of Nuclear facilities in London) the information on qualities and quantities from different decommissioning projects were sampled. Besides these sources there are some other sources from which information can be expected, but which are not available for the moment. We hope that within the next 6 months we will be able to gather all relevant public sources according to this subject. In order to become the necessary information, different companies and research institutes have been contacted. As soon as the different types of steel are known, we start the organisation for getting samples of these types of metal in 3 different shapes: fibres, granules and curls. The fibres will be produced according to our specification. For both, granules and curls, we are in contact with potential suppliers which might be able to produce the wanted quantity and quality.

Progress and results (B.1, B.2)

1. The quantity and quality of the contaminated metal scrap

From the literature /1/, /2/, /3/, /4/ it can be seen that the main types of metal are stainless steel and mild steel. There are some other types of non-ferrous metal like Copper. But these are, as far as the information in our literature sources confirms, only small in quantity compared with stainless and mild steel.

In table I some specific data about steel quantities and qualities are given, though it must be stated that we are still waiting for some reports. But from the different sources we already studied (/1/, /2/, /3/), there was no big difference in quantities and qualities.

It should be clear that the figures given in the table are general informations only. The amounts for each individual nuclear installation will depend on the time between shut down and start of the decommissioning, type of reactor, duration of operation, etc. Nevertheless, they are permitting to choose the types of metal for our research program:

- Stainless steel 304
- Stainless steel 316
- Mild steel (18% Cr, 8-10% Ni)

For reason of low quantities non-ferrous metal is excluded from the research program. About the amount of metal scrap

that will be released in the nearest future we are still waiting for further information.

Research on metal-concrete composites (B.2.)

Based on the results of the literature study we are preparing the metal-concrete tests by first doing some preliminary tests about the exact mixture of metal and concrete. Concerning fibres we found a company willing to produce these fibres according to our specifications. The application of steel fibres in concrete is well known, but investigations with different steel qualities have not yet been undertaken. Both steel granules and curls are new applications for which not only the mechanical properties but also the workability-aspects have to be looked at in the next step.

References

- /1/ CHAPUIS, A, Commission of the European Communities report EUR 10058 EN (1985).
- /2/ BOORMAN, T, International Seminar on Decommissioning of Nuclear Facilities, Proceedings Planning and Progress of the WAGR Decommissioning Project (1988).
- /3/ LOURME, et al, 1987 International Decommissioning Symposium, Pittsburgh, 4-8 october 1987, Proceedings p.p. V-34 V-55.
- /4/ ASHCROFT, et al, 1987 International Decommissioning Symposium, Pittsburgh, 4-8 october 1987, Proceedings p.p. VI-29-VI-47.

Table I: Amounts and activity of contaminated steel from several types of nuclear installations.

Steel type	Steel mass (t)	surface activity Bq/cm ²	total activity (Bq)
1 miscellaneous	800	37-370	8 * 10 ⁹
1 miscellaneous	1600	3.7-37	1.6 * 10 ⁹
1 miscellaneous	3200	0.37-3.7	0.3 * 10 ⁹
2 stainless steel	90	-	2.2 * 10 ⁹
2 mildsteel	760	-	0.5 * 10 ⁹
3 mild steel	2500	20	-
4 mild steel	420	-	85-1200*10 ⁹
4 stainless steel	20	-	1200-1700*10 ⁹

- 1 Results given for a PWR Reactor 1/
- 2 Results given for decommissioning of Windscale 2/
Advanced Gascooled Reactor 7 years after shut down

down

- 3 Results given for decommissioning G2-reactor 3/
- 4 Results given for decommissioning of Windscale 4/
Advanced Gascooled Reactor of the principal active
steel arisings (both activated and contaminated
steel)

4.4. TREATMENT AND CONDITIONING OF RADIOACTIVE GRAPHITE FROM NUCLEAR INSTALLATIONS

Contractors: CIEMAT, UDA
Contract No.: FI2D-0017
Work Period: July 1990 - December 1993
Coordinator: A ESTEBAN DUQUE, CIEMAT, Madrid
Phone: 34/1/346 62 19 Fax: 34/1/346 60 05

A. OBJECTIVE AND SCOPE

The objective of the laboratory-scale investigations is the development of chemical processes for the treatment of radioactive graphite for its safe storage. It consists in:

- previous extraction of radionuclides (mainly tritium) to decrease the radioactivity of graphite;
- fixation of radionuclides (mainly C-14) to avoid their leaching during the storage of graphite;
- impermeabilisation of graphite by metal coating for its transport and storage.

Extraction of the radionuclides with chemical agents will be done before the metallising process for fixation, in order to minimise leaching of radioactive products during storage, followed by standard leaching tests. The radioactive graphite will be procured from the experimental reactor JEN-1 and the gas-cooled reactor Vandellos-I.

B. WORK PROGRAMME

B.1. Removal and/or fixation of radionuclides

- B.1.1. Investigations on radioactive and inactive sample structure and texture using different analysing techniques. (all)
- B.1.2. Testing of appropriate chemical agents on samples with regard to their possible decontamination and/or immobilisation features. (UDA)
- B.1.3. Study of radionuclide removal, mainly titanium.
- B.1.4. Study of radionuclide fixation.
- B.1.5. Characterisation of treated samples using methods from subtask B.1.1.

B.2. Metal coating of graphite by ionic deposition.

- B.2.1. Characterisation of samples similar to B.1.1. (all)
- B.2.2. Performance of process parameter studies for metal coating applications on inactive samples. (all)
- B.2.3. Chemical modification of radioactive surfaces. (CIEMAT)
- B.2.4. Metallisation of inactive samples. (all)
- B.2.5. Metallisation of radioactive samples. (CIEMAT)
- B.2.6. Characterisation of the treated samples concerning chemical properties and thickness of the metal layer, porosity of the surface etc. (all)

B.3. Leaching experiments with the metallised specimen. (CIEMAT)

B.4. Assessment of results and conclusions.

C. PROGRESS OF WORK AND OBTAINED RESULTS

Summary of main issues

This period of the time has been devoted to the implementation of the project and the adjustment of laboratories, equipments and characterisation techniques. Samples of inactive and active graphite from experimental reactor JEN-1 and gas-cooled reactor Vandellos-I have been obtained.

The following characterisation studies have been achieved using inactive graphite samples:

- X-ray diffraction
- nitrogen adsorption
- mercury porosity
- water and carbon analysis.

Progress and results

1. Investigations on radioactive and inactive sample structure and texture using various analysing techniques (B.1.1., B.2.1.)

The inactive graphite samples originate from the reflector of JEN-1 experimental reactor (R-samples) and from the fuel shirts of Vandellos-I gas-cooled reactor (C-samples). The graphite dust samples had a grain size between 6-12 μm and 60-100 μm .

Analysis of the graphite structure

X-ray diffraction technique was applied to study the structure of graphite with a SEFER J50 equipment. The graphitisation grade is less on C-samples than on R-samples, where the graphitisation is non-homogeneous (Table I).

Study of the graphite surface

The active surface has been studied by adsorption isotherms of nitrogen with a COULTER OMNISORP 100 CX equipment. An example of these results is given on Figure 1. Very high specific surfaces 13-15 m^2/g were obtained on C-samples and less 6-8 m^2/g on R-samples. These values agree with the results obtained with X-ray diffraction study. The SBET parameter is similar on R and C-samples, therefore the interaction between N_2 and both graphites will be similar.

The porosity has been studied with a CARLO ERBA 2000 porosimeter. The results are given on Table II and an example of these results is depicted on Figure 2. The mesopores volume on dust and grain samples were 0.014 cm^3/g and 0.021 cm^3/g respectively for R-graphite and 0.040 cm^3/g and 0.083 cm^3/g for C-graphite. The macroporosity was 0.083 cm^3/g on R-graphite and 0.040 cm^3/g on C-graphite.

2. Testing of appropriate chemical agents on samples with regard to their possible decontamination and/or immobilisation features (B.1.2.)

The analysis of water and carbon content (Figure 3) have shown the presence of water and hydrocarbons on the surface as well as hydrocarbons inside the graphite structure. They were extracted at a temperature of about 400°C.

The adsorption and desorption of water and hydrogen have been studied. The obtained results show the adsorbed water on samples C is desorbed completely but on R-samples, part of it is retained.

3. Performance of process parameter studies for metal coating applications on inactive samples (B.2.2.)

A bibliographic study on the matter has been realised.

Table I: X Ray Diffraction of Graphite Samples R an C

Graphite Sample	2θ	D(Å)	Irel	Imax	Graphite Sample	2θ	D(Å)	Irel	Imax
R1	23.8	3.74	0.7	70	C1	23.8	3.74	1.8	177
	26.4	3.37	100.0	10416		26.4	3.38	100.0	9628
	27.2	3.27	1.5	160		27.2	3.28	3.1	300
	42.5	2.13	1.0	107		42.5	2.13	1.2	118
	44.3	2.04	1.6	171		44.1	2.05	1.6	156
	54.4	1.68	4.2	442		54.4	1.69	4.1	393
	77.4	1.23	1.0	105		77.4	1.23	1.2	115
R2	23.9	3.73	1.0	111	C2	23.8	3.74	1.3	112
	26.5	3.36	100.0	11314		26.4	3.38	100.0	8823
	27.3	3.26	1.6	178		27.2	3.28	2.2	195
	42.5	2.13	0.8	85		42.4	2.13	1.0	92
	44.4	2.04	1.3	150		44.4	2.05	1.4	125
	54.5	1.68	4.0	452		54.3	1.69	4.3	376
	77.5	1.23	0.9	102		77.4	1.23	0.9	83
R3	23.8	3.74	1.2	122	C3	23.8	3.74	1.3	122
	26.4	3.37	100.0	10332		26.4	3.37	100.0	9612
	27.2	3.27	1.9	195		27.2	3.27	2.2	212
	42.4	2.13	1.1	114		42.5	2.13	0.8	79
	44.3	2.04	1.8	189		44.2	2.05	1.1	110
	54.4	1.69	4.1	428		54.4	1.69	4.2	408
	77.4	1.23	1.0	10		77.5	1.23	0.8	72

Table II: Volume of Pores by Mercury Porosimetry

Graphite Sample	Volume of Mesopores (cm ³ /g)		Volume of Macropores (cm ³ /g)
	Dust (60-100 μ)	Grain (1-3 mm)	Grain (1-3 mm)
	R < 25 nm		R > 25 nm
R1	0.014	0.021	0.079
R2	0.014		
R3	0.016		
C1	0.018		
C2	0.018	0.030	0.040
C3	0.023		

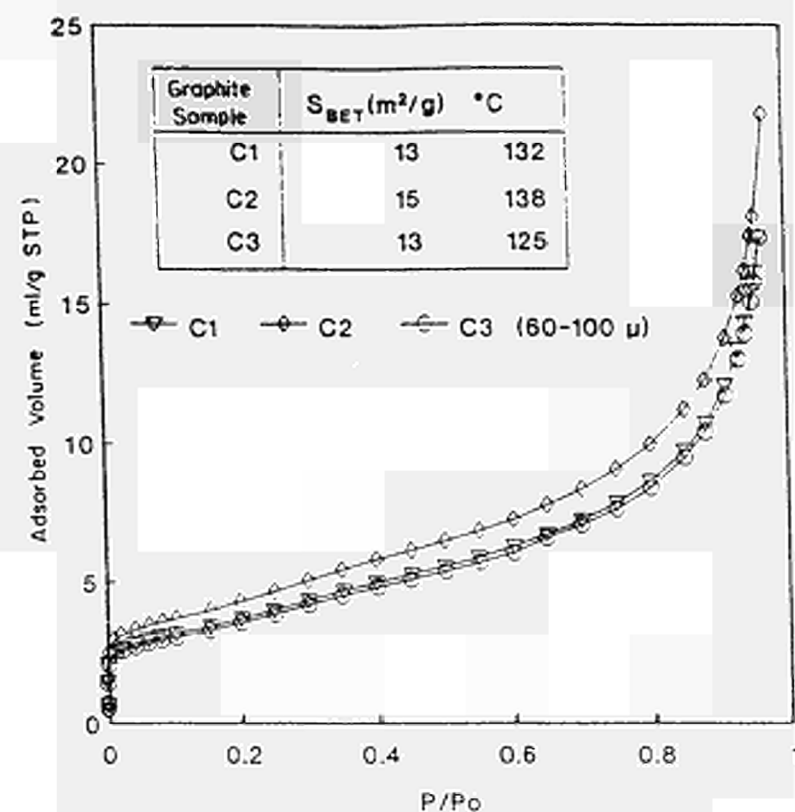

Fig. 1 : N_2 Adsorption Isotherms ($77^{\circ} K$)

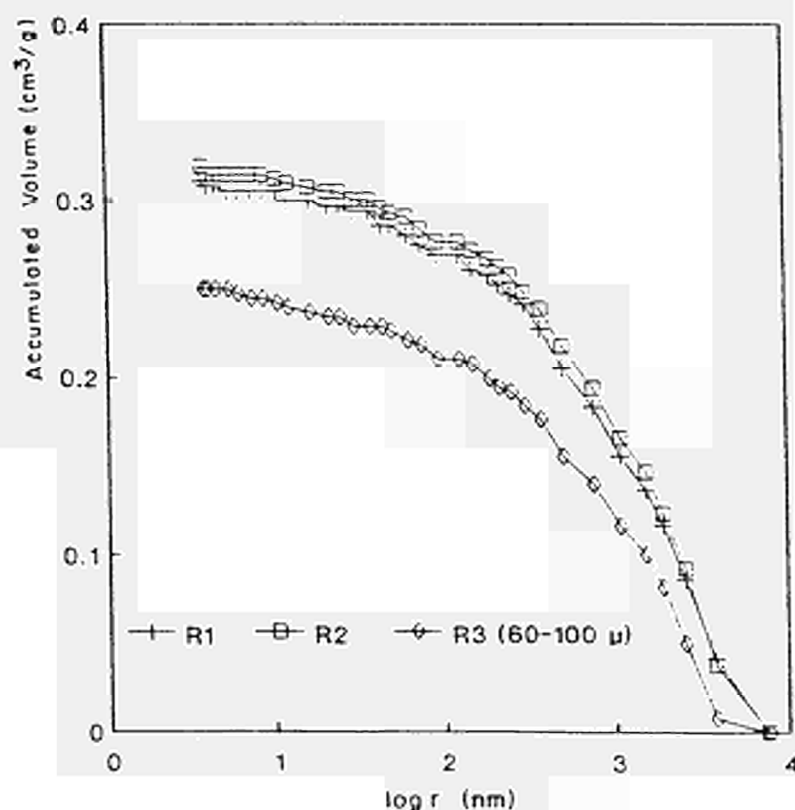

Fig. 2 : Mercury Porosimetry

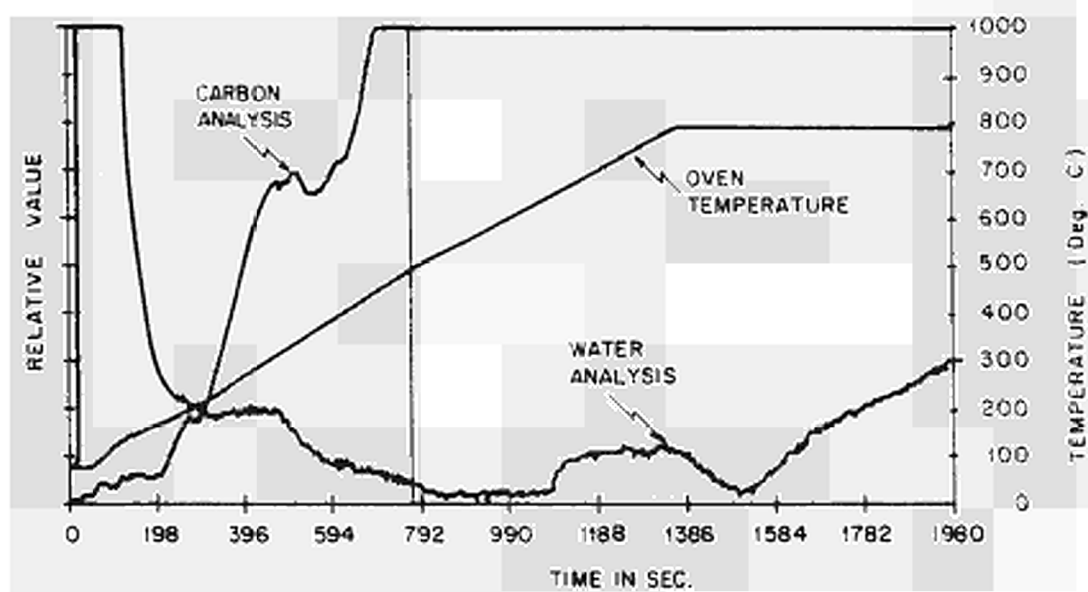

Fig. 3 - Carbon and Water Analysis

5. AREA No. 5: QUALIFICATION AND ADAPTATION OF REMOTE-CONTROLLED SEMI-AUTONOMOUS MANIPULATOR SYSTEMS

A. Objective

Because of radiation fields, some decommissioning tasks must be performed with remote control, in order to minimise occupational exposure. This requirement forms a major technical challenge in decommissioning.

The objective of this research is to qualify and adapt remote-controlled semi-autonomous systems for manipulation of decommissioning tools and instruments.

B. Subjects of the research performed under the previous programmes (1979-88)

Remote-controlled manipulation systems did not form the subject of a Project Area of its own, so far, but limited activities in this field were performed under Projects No. 2 (Decontamination) and No. 3 (Dismantling techniques).

C. Programme 1989 to 1993

Remote-controlled semi-autonomous manipulators should be adapted and tested, in order to qualify and improve their performances with typical decommissioning tasks and tools. For this purpose, existing components and sub-systems should be used and adapted as far as feasible. This concerns in particular sensing systems and computer programmes for semi-autonomous process control, which form important aspects of the research. Special attention should be paid to highly repetitive time-consuming operations, e.g. decontamination and clearance measurements of large surface areas of premises.

D. Programme implementation

At the end of 1990, six research contracts relating to Area No. 5 were at the stage of execution.

5.1. ROBOTIC SYSTEM FOR DISMANTLING OF THE PROCESS CELL OF A REPROCESSING PLANT

Contractor: ENEA, CRE Trisaia
Contract No.: FI2D-0006
Work Period: October 1990 - December 1993
Project Manager: P MATALONI
Phone: 39/835/97 43 94 Fax: 39/835/97 42 50

A. OBJECTIVE AND SCOPE

Most reprocessing plants, at the end of their lifetime, consist of small shielded cells, inside which the process equipment is installed. The plant philosophy required the operator to enter the cells for any maintenance interventions; the cells are usually accessible from a top corridor through openings closed by shielded plugs.

The present research projects aims at testing a robotic system that can dismantle the equipment of a small cell of this type and remove cut parts from the cell without any direct intervention of the operator. The envisaged robotic system consists in a servomanipulator (MASCOT IV) and a hoist installed inside a containment box; the box has the purpose of avoiding the dispersal of contamination both during the cutting operations and during the transfer of the cut parts to the conditioning cell.

The robotic system will be tested using a mock-up of the dissolution cell of the EUREX plant, built according to the criteria of small shielded cells.

B. WORK PROGRAMME

- B.1. Design and construction of a mock-up of the dissolution cell of the EUREX plant**
- B.2. Design and construction of a containment box and installation of the MASCOT IV servomanipulator**
- B.3. Non-radioactive testing of the robotic system with dismantling operations, using the cell mock-up.**
- B.4. Non-radioactive testing of the robotic system with simulated cell decontamination operations, including simulated smear tests.**
- B.5. Specific data on costs of the system and its radiological impact on work force and working area.**

C. Progress of Work and Obtained Results

Summary of main issues

The activity concerning the research has a commencement date of 1st December 1990. The contract between European Community and E.N.E.A. was signed at the beginning of 1991.

The activity has been centred on the design of the robotic system (Task B.2). The design criteria of the containment box have been fixed.

Progress and Results

1. Wording of the first title (B.2)

The robotic system consists of a servomanipulator (MASCOT IV) installed inside a containment box. The box communicates with the cell by means of a hole closed by a double lid system. A telescopic tube, mounted on a carriage, supports the MASCOT; its elongation is about 5 metres.

The box dimensions have been chosen according to the MASCOT dimensions; the height also according to the telescoping tube length.

The box preliminary design (Figure 1) is 4 metres long, 2.2 metres wide and 4 metres high; the possibility of reducing the dimensions is under consideration now (smaller dimensions simplify the box positioning).

A hole is present at the bottom of the box; it is square so as to allow box different orientations; it is about 1.2 metres wide.

The box dimensions allow the extraction of most of the appliances from the process cells; the bigger ones (e.g. the dissolver in the case of the dissolution cell) are cut inside the cell before they are extracted.

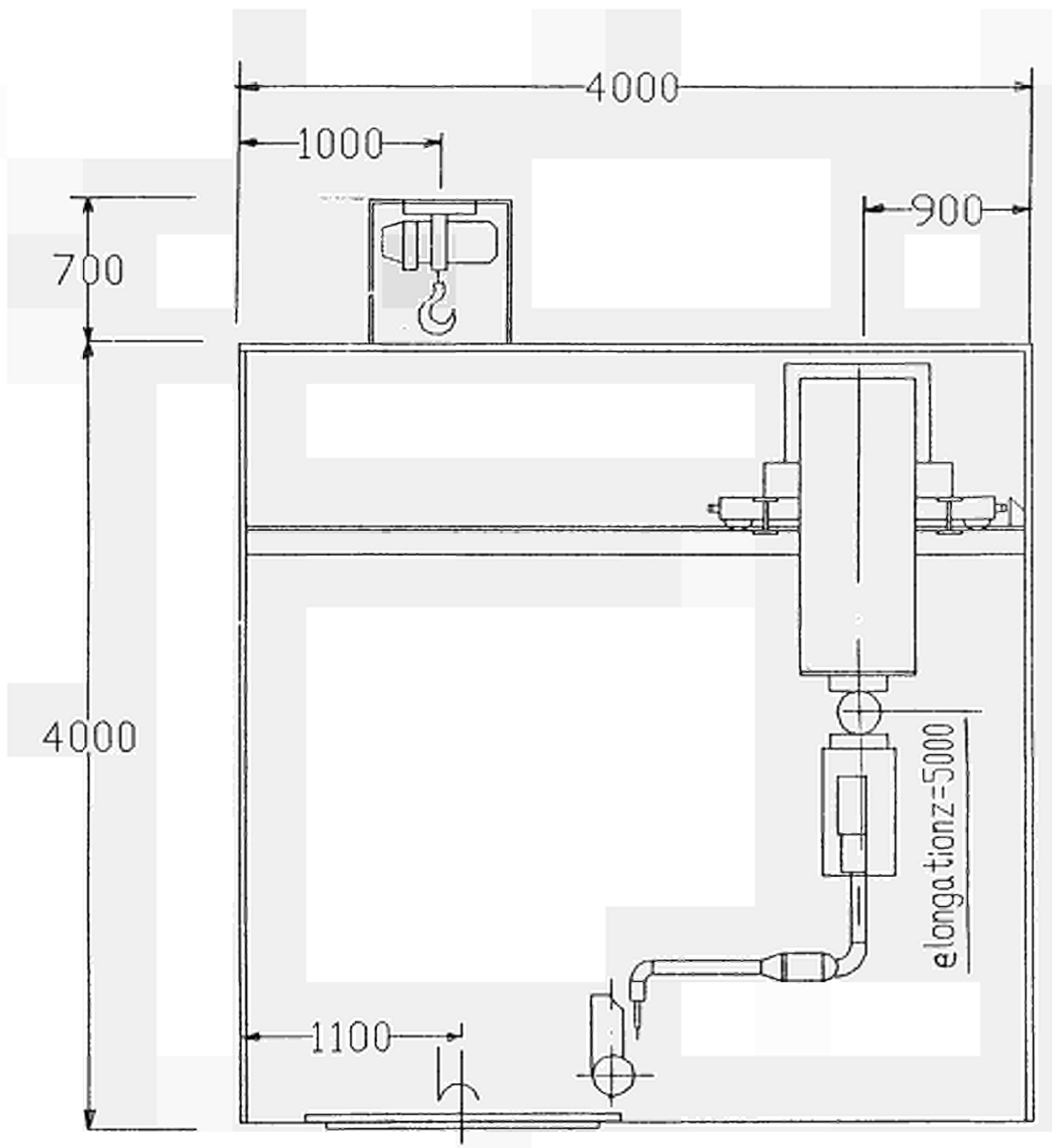

Fig.1 Robotic system-Preliminary Design

5.2 DESIGN, CONSTRUCTION AND TESTING OF A MANIPULATOR FOR REMOVING SLAG, MEASURING TEMPERATURE AND TAKING SAMPLES DURING MELTING OF RADIOACTIVE METAL

Contractors: ANSALDO, Siempelkamp
Contract No.: FI2D-0008
Work Period: July 1990 - March 1993
Coordinator: M CIARAVOLO, DNU/RTL, ANSALDO S.p.A.
Phone: 39/10/550 27 90 Fax: 39/10/550 20 32

A. OBJECTIVE AND SCOPE

The work consists essentially in the improvement of an existing melting procedure for radioactive materials and mainly relates to:

- a system specification including a preliminary study to identify the most appropriate manipulator system,
- the components design and manufacturing,
- modifications of the existing melting plant for components housing,
- installation of the components and testing of the system.

The expected benefits relate mainly to a reduction of the radiation dose to the melting staff and a reduction of the contamination in the area surrounding the furnace - operations such as slag removing, temperature measuring and samples taking being nowadays carried out completely manually. The manipulator should also increase the efficiency of the melting technique.

The manipulator developed here has thus to:

- keep people away from the furnace while it is open, in order to avoid their radiation/contamination by the melt, in particular through inhalation of radionuclides leaving the melt;
- reduce the contamination of the surroundings of the furnace (nuclides like the volatile caesium leave the open furnace);
- remove dust during melting of zinc-plated metal.

The work is a follow-up of previous EC contracts (FI1D-0016, -0047 and -0059) under which Siempelkamp and KGB Gundremmingen developed the melting facilities TAURUS I, II and CARLA.

B. WORK PROGRAMME

B.1. System requirements such as basic operations, environmental conditions, interfaces will be specified (Siempelkamp)

B.2. System definition (Ansaldo)

B.2.1. Selection of the basic concept, performing the three operations required, and comparison with a single-purpose device.

B.2.2. Definition of main manipulator operations required, i.e. scumming, sampling, and temperature measurements of the furnace melt bath.

B.3. Design of the defined system components (Ansaldo)

B.4. Manufacturing and shop testing of components (Ansaldo)

B.5. Modification of the existing facility (Siempelkamp)

B.6. System installation and testing in the Siempelkamp melt shop CARLA (All)

B.6.1. Cold tests, e.g. tool changing, manipulator working autonomy, at ambient temperature.

B.6.2. Tests at operational thermal conditions.

B.6.3. Tests with radioactive material < 74 Bq/g, i.e. carbon steel, stainless steel, steel plates covered with zinc, brass, copper and aluminium.

B.7. Final evaluation with regard to costs, melt time, safety, occupational radiation exposure and radioactive emissions to the environment (All)

C. Progress of work and obtained results summary of main issues

During the 1990 basic concepts of the system have been developed considering the main operations.

The layout of the manipulator and of the insulation system have been defined considering the Carla Plant interface dimensions.

Procedures for the process have been studied considering the main operations (Scumming, sampling and temperature measurements).

Progress and results.

1. System requirements such as basic operations, environmental conditions, interfaces will be specified (Siempelkamp) B.1.

System requirements and basic operations (Scumming, Sampling and temperature measurements) have been defined in the Spc. 915-000-000 index 0 issued by Siempelkamp.

In the specification, the environmental conditions as temperature radiations and pressure and the interface dimensions of the plant are considered. Other main interfaces such as barrel dimensions have been fixed.

The whole process has been examined identifying auxiliary operations (e.g. scumming tool, grab coating and cleaning), necessary for the melting process but not originally described.

These auxiliary operations have been introduced to permit the complete process and the insulation between the furnace and the Carla Plant.

2. System definition (Ansaldo) B.2.

2.1 Selection of the basic concept, performing the three operations required, and comparison with a single-purpose device. B.2.1.

Considering the three operations (scumming, sampling, and temperature measurements) a comparison between a multi-purpose manipulator and single-purpose devices has been performed. Due to the necessity of enclosing all the

facilities in an insulating box (to avoid decontamination speed in the plant environment) and to the space constraints of the existing plant, a multi-purpose manipulator has been preferred.

2.2 Definition of main manipulator operations required, i.e. scumming, sampling, and temperature measurements of the furnace melt bath. B.2.2

The manipulator is foreseen installed inside an insulation room to prevent contamination of the dust from the furnace in the Carla hall.

In the ANSALDO specification n. DEC SIE S001 Rev. 0 the manipulator is described. A telescopic mast has been chosen to permit a great stroke of the end effector.

The mast can rotate and translate to reach the furnace and the tools expositions inside the insulation room.

A particular slag grab has been studied to remove the slag from the edge of the crucible. The grab has two hemispherical jaws and an helical blade fixed at its periphery. The temperature measurement will be obtained using thermocouples automatically connected to the mast.

An optional pyrometer could be used to obtain a fast knowledge of the temperature.

The insulation room will be provided with auxiliary devices to change the slag barrel and tools, to clean and paint the grab and to take slag-samples.

Sensors will be installed to control the operations.

A TV camera will be placed for supervisors control during the process.

5.3. TELEROBOTIC MONITORING, DECONTAMINATION AND SIZE REDUCTION SYSTEM - TMDSRS

Contractors: AEA Harw., SCK/CEN
Contract No.: FI2D-0012
Work Period: July 1990 - December 1993
Coordinator: M H BROWN, AEA Harwell
Phone: 44/235/434 691 Fax: 44/235/436 138

A. OBJECTIVE AND SCOPE

The objective of this work is to use existing equipment developed under the Harwell Nuclear Robotics Programme to investigate and demonstrate the feasibility of telerobotic monitoring, decontamination and size-reduction systems (TMDSRS). The work will include experimental investigations at industrial scale, and use sample workpieces of an appropriate size and configuration similar to their active counterparts.

The work will proceed in two distinct stages. The first stage will involve the continued development of the Harwell Telerobotic Controller and its interface to NEATER, a Nuclear Engineered Advanced Telerobot, and ancillary equipment and mechanisms. This development will allow in-active trials of a TMDSRS system on each of the three sets of target workpieces (B.3., B.4. and B.5.). The work will be carried out in the Harwell Robotics Demonstration laboratory.

The second stage of the work (B.6.) will involve active trials of one of the areas demonstrated in the first stage. The selection of the appropriate application will ensure that a safe, useful and representative active trial can be accomplished.

This development will reduce man-Sv and costs of decommissioning projects. Greater efficiencies in placing or deploying decontamination tools and in cutting and packing waste will improve waste disposal strategies, and reduce waste arisings. Data on cost benefits will be produced in submissions made to justify the selection of a suitable project for the active trials (phase 2). Cooperation on sensors with SCK/CEN Mol is included in the work programme.

B. WORK PROGRAMME

B.1. Control system extension to work effectively with each of the three non-active applications.

B.2. Electropolishing head unit development and irradiation tests (AEA)

B.2.1. Requirements analysis for the electropolishing head unit (AEA)

B.2.2. Requirements analysis for the sensor functions (SCK/CEN)

B.2.3. Selection of sensors to meet the requirements analyses of B.2.1. and B.2.2. (SCK/CEN)

B.2.4. Design and construction of the integrated head unit (AEA)

B.2.5. Irradiation tests of the integrated head unit (SCK/CEN)

B.3. Decontamination of different surfaces; radiation monitoring, electropolishing and registration software (AEA)

B.4. Clearance monitoring developments (AEA)

B.5. Glovebox size reduction developments

B.5.1. Analysis of subsystems susceptible to radiation damage (SCK/CEN)

B.5.2. Tests on subsystem components in the gamma irradiation test facility at the BR2 reactor (SCK/CEN)

B.5.3. Tool and operational software development (AEA)

B.5.4. Tool change adaptation and cutting tasks demonstration jointly with a range of tools (AEA)

B.6. Active decommissioning trials in the appropriate active area

B.6.1. Pre-trial analysis of the radiation environment (AEA)

B.6.2. Active trials including the NEATER carrying out of a task or set of tasks (AEA)

B.6.3. Support for active trials to reduce the probability of failures (SCK/CEN)

B.7. Economic analysis of TMDSRS and its radiological impact on work force and working area

B.7.1. Pre-active trial cost-benefit analysis to establish economic advantages of telerobotic operations (AEA)

B.7.2. Post-active trials analysis on costs, incurred dose burdens, working and exposure times of ancillary operators, and estimates of secondary waste arisings (AEA).

C. Progress of Work and Obtained Results

Summary of main issues

An analysis of the Electropolishing Head Unit [EHU] requirements has started late because of the delay in issuing the contract amendment to incorporate CEN/SCK into the project. To compensate the Glovebox Size Reduction, work programme has been brought forward. The telerobotic control system software has been extended to host force control algorithms for bilateral [force reflecting] teleoperation and automatic drill bit alignment. Radiation monitoring and registration software to facilitate the detection and decontamination of radiation hot spots has been specified. To improve the cost effectiveness of the telerobotic size reduction of gloveboxes, compliant mounts for aggressive cutting tools have been developed and their performance evaluated.

Progress and Results

1. Background

The key elements of the TMDSRS are the Nuclear Engineered Advanced TeleRobot [NEATER], a TeleRobotic Controller [TRC] and a six degree-of-freedom input device to provide man-in-the-loop operation.

NEATER is based on Stäubli Unimation's clean room industrial robot, the PUMA 762 CR. To provide a cheap and reliable alternative to complex force reflecting manipulators, designed especially for the nuclear industry, deviations from the standard product have been kept to a minimum. It is modular for ease of maintenance, fully sealed for prevention of contamination and radiation tolerant to 1MGy. A prototype was delivered to Harwell in December 1989 on completion of an eighteen month development programme. Since then it has accumulated over 1500 hours of operation (figure 1).

The TRC has been designed to provide effective unilateral or bilateral teleoperation and a host for sensor-based control algorithms such as those required for decontamination and tool alignment. It runs on an IBM compatible 80486 based PC and is connected to Unimation's VAL II controller via a standard communications interface. A menu-driven touchscreen provides a user-friendly operator interface.

A six degree-of-freedom Cartesian Master Arm [CARMA] has also been developed, under separate funding, to provide, via the TRC, unilateral control of NEATER. Bilateral operation will be available in April 1991.

2. Control system extension (B1)

Recent extensions to the software provide the option to communicate with the robot controller via its SLAVE software. SLAVE facilitates robot control through singularities, telerobotic configuration changes and interfacing to other servomanipulators. Work has started on a high speed version of SLAVE to provide effective force control for bilateral teleoperation and telerobotic tool deployment. The new version, scheduled for completion in September 1991, will reduce control system cycle times from 28mS to 3.6mS. A prototype Ethernet link has been developed to support the faster data rates required for Enhanced SLAVE. The TRC will host the application specific software necessary to meet the requirements of the three TMDSRS applications.

To provide a more effective man machine interface than the standard two unilateral three degree-of-freedom joysticks the six degree-of-freedom CARMA has been interfaced to the TRC. The interface includes ADC hardware and scaling software to input cartesian

position data from CARMA and motor drive amplifiers to power the force reflecting motors. Bilateral force control algorithms are implemented in the TRC. A six degree-of-freedom force/torque sensor has also been interfaced to the TRC. This sensor provides robot end point force/torque data for a range of force control algorithms including bilateral tele-operation.

3. Electropolishing head unit (B2)

A list of candidate EHU materials requiring an assessment for chemical stability in the presence of nitric acid and ionising radiation has been produced. EHU sensor requirements have also been identified.

4. Surface decontamination (B3)

The robotic decontamination of flat surfaces using the electropolishing head unit will be controlled by radiation monitoring and registration software. A requirements analysis for this task has been completed and a software specification issued. The software is required to scan the EHU over a specified flat surface on a pre-programmed grid, pausing at each monitoring point for twenty seconds. Position and radiation measurements will be recorded at each monitoring point to enable the generation of a radiation map of the scanned area. The system must provide a graphical display at a monitor and a hard copy via a commercial spreadsheet. Position data storage will enable the robot to return to radiation hot spots with the EHU. The application software will be fully integrated with the TRC software and accessible through the touchscreen. Application and EHU specific parameters will be selectable to enable other decontamination heads to be deployed in this way.

5. Glovebox size reduction (B5)

Telerobotic cutting trials have been carried out on a wide range of tools. The main objective was to define a tool kit before the commencement of size reduction operations on typical gloveboxes to confirm or otherwise predicted decommissioning times. New tools have been tested and deployment techniques for existing tools developed. Passive compliant mounts have been designed to meet the specific telerobotic deployment requirements of a nibbler, bandsaw and reciprocating saw. The aim is to eliminate robot stalling by minimising the tool misalignment forces applied to the robot end effector.

Rotary drills are required to provide access holes for jigsaws and reciprocating saws. Trials have shown that it can take as long as five minutes to align the drill bit telerobotically. To reduce this time an algorithm has been developed to align a drill bit orthogonal to a surface. Maximum alignment time is 20 seconds and occurs when the approach angle is greater than 45° from the vertical. If an operator is able to align telerobotically the drill bit closer to the desired orthogonal position, then the execution time is reduced to ten seconds. These times are much faster than the typical manual alignment times. Automatic alignment is also much more accurate than manual methods and consequently cutting efficiency is improved. During the execution of the alignment algorithm the drill bit touches the surface and the force/torque vector is read from the sensor. The required position of the robot is then computed to ensure that there is a single force along the drill bit axis, other forces and torques being set to zero. To provide a robust algorithm, a dynamic model of the VAL II controller was obtained from Unimation.

Trials with proprietary pneumatic jaw grippers from Cleveland Guest showed that they were able to lift waste arising from glovebox decommissioning trials. Vacuum grippers were, however, much more effective at lifting flat plates. Prototype vacuum gripper trials

revealed the difficulty of aligning the pads with waste metal that was not resting in the horizontal plane. To overcome this problem the gripper mount was modified to provide compliance. The new mount accommodates over 45 degrees of misalignment between the component to be lifted and the wrist mounting face. Further trials have demonstrated that the modified system allows quick and easy pick and place of sawn-off plates.

To permit size reduction tools to be changed remotely, a tool change system has been purchased from Stäubli Unimation. A prototype tool change rack has been designed to meet glovebox decommissioning requirements/and manufacture is underway. Supporting tool change software has been specified; a prototype version is scheduled to be coded by March 1991.

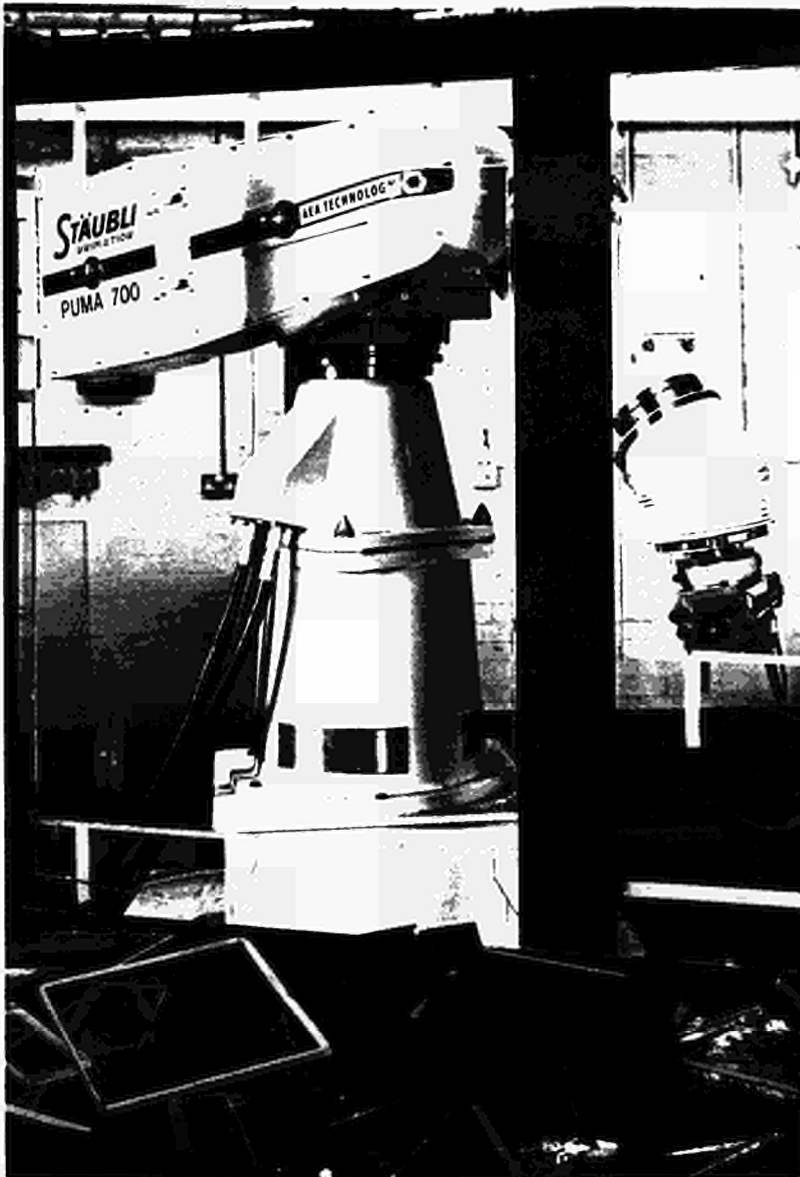

Figure 1: Adapted industrial robot.

5.4. ADAPTATION AND TESTING OF A REMOTELY CONTROLLED UNDERWATER VEHICLE

Contractor: AEA Winf.
Contract No.: FI2D-0025
Work Period: July 1990 - June 1993
Project Manager: P W WORTHINGTON, AEA Windscale
Phone: 44/9467/72414 Fax: 44/9467/28989

A. OBJECTIVE AND SCOPE

Preparatory work to decommission the Windscale piles is being carried out. As part of this work, fuel debris and contaminated silt is to be recovered from two water-filled, 100 m long, 2.7 m x 2.1 m section fuel transfer ducts which connect the piles to the fuel storage pond.

As no commercial equipment exists which has been purpose-designed for generic nuclear applications, the main object of this work is to adapt and test a remotely controlled underwater vehicle provided with manipulators, on-board television systems and remote sensors for surveillance purposes. This includes the development of an underwater remotely controlled vehicle for use in nuclear applications, the development of techniques for fuel handling and silt recovery, and the assessment of equipment durability, radiation tolerance and of decontamination problems, e.g. removal of concrete surfaces, etc.

The potential benefits of this work programme will be reduced doses to workers, decontamination and inspections, reduced secondary waste and reduced decommissioning costs due to lower labour input.

Information on costs, occupational exposure, work time and secondary waste arisings will be made available.

The work will include non-active trials in a full-size mock-up.

B. WORK PROGRAMME

- B.1. Specification of the underwater vehicle, to allow manufacturers to tender.**
- B.2. Vehicle manufacture, at the tenderer's work.**
- B.3. Preparation of the full-size test mock-up of the entrance area to the water duct.**
- B.4. Adaptation and testing in the mock-up of the vehicle/system on its ability to perform the various decommissioning tasks.**
 - B.4.1. Dry testing of the complete system.
 - B.4.2. Wet testing of the complete system.
- B.5. Development in the active environment of Windscale Pile No. 1.**
- B.6. Final evaluation will include specific data on costs, work time, occupational exposure and the secondary waste arising from the technique.**

C. Progress of work and obtained results

Summary of main issues

The main issues undertaken in this first year of the work programme are the preparation of the specification for the underwater vehicle, the manufacture of the vehicle and the preparation of a mock-up for vehicle development.

Progress and results

1. Specification of the underwater vehicle to allow manufacturers to tender (B.1.)

The detailed specification for the vehicle has been written and completed in accordance with the programme. The specification is divided into two main parts:

- (i) General contract conditions for all work carried out on behalf of AEA Technology;
- (ii) Technical requirements of the vehicle. This details minimum reach, minimum lift capacity and access restrictions.

This specification was used as the basis for suitable manufacturers to tender against. These tenders have been received and analysed.

2. Vehicle manufacture at the tenderer's works (B.2.)

The manufacture of the vehicle has been delayed because of changes in the financial sanctioning arrangements within AEA Technology. It is now forecast that vehicle manufacture will commence in March 1991.

3. Preparation of the test mock-up (B.3.)

The facility is under construction at Windscale Site and will be completed to programme.

4. Adaption and testing of the vehicle on its ability to perform the various decommissioning tasks (B.4.)

B.4.1. work schedules are being produced for fuel retrieval and operator training, and assessment programmes for vehicle and manipulator assessment are in preparation.

5.5. TEST OF LONG-RANGE TELEOPERATED HANDLING EQUIPMENT WITH DIFFERENT TOOLS FOR CONCRETE DISMANTLING AND RADIATION PROTECTION MONITORING

Contractors: KfK, KA, AEA Harw., BAI
Contract No.: FI2D-0032
Work Period: October 1990 - December 1992
Coordinator: K MÜLLER, PHDR/HT, KfK
Phone: 49/7247/824343 Fax: 49/7247/823718

A. OBJECTIVE AND SCOPE

An existing advanced handling system (EMIR) will be used as a carrier system for various devices for concrete dismantling and radiation protection monitoring. It combines the advantages of long reach and high payload with highly dexterous kinematics.

This system will be enhanced mechanically to allow the use of different tools. Tool attachment devices for automatic tool exchange will be investigated as well as interfaces (electric, hydraulic, compressed air, cooling water and signals).

The control system will be improved with regard to accuracy and sensor data processing. Programmable logic controller (PLC) functions for tool control will be incorporated. The free field of the EMIR will be used to build a mock-up that allows close simulation of that scenario without radioactive inventory. Aged concrete will be provided for the integration tests.

Finally, the economical and technical effectiveness of the different methods will be assessed/evaluated.

B. WORK PROGRAMME

B.1. Basic concept investigation

- B.1.1. Interface specification between tools and EMIR (KfK)
- B.1.2. Investigation of tool attachment devices for an automatic tool exchange system (KfK)
- B.1.3. Setting up of test parameters (All)
- B.1.4. Literature review concerning tool holders, adapters and tool replacement (KA)
- B.1.5. Selection of the tool replacement system (KA)
- B.1.6. Microwave equipment; design concept and interface specification (AEA)
- B.1.7. Literature review on automation and measuring (BAI)
- B.1.8. Selection of the type of radiation detector (BAI)
- B.1.9. Definition of contaminants (BAI)
- B.1.10 Design of the mechanics involved (BAI)
- B.1.11 Electronics design for a noisy and dirty environment (BAI)
- B.1.12 Conception of the hardware requirements for the computing system (BAI).

B.2. Development of tools

- B.2.1. Development of a tool positioning sensor (KfK)
- B.2.2. Design and manufacture of a sensor equipment (KfK)
- B.2.3. Examination of kinematic requirements (KfK)
- B.2.4. Enhancement of control system (KfK)
- B.2.5. EMIR hardware enhancement (mechanical and non-mechanical interfaces) (KfK)
- B.2.6. Setting up and optimisation of test parameters (KfK)
- B.2.7. Adaptation of a commercial tool replacement system or development of an appropriate system (KA).
- B.2.8. Development of a tool replacement adapter system suited to EMIR requirements (KA)
- B.2.9. Installation of radiation measuring instrument plug connectors in the adapter (KA, BAI)
- B.2.10 Tool holder rack design and development (KA)
- B.2.11 Tool adapter plates, tool store and tool replacement equipment manufacturing (KA)
- B.2.12 Assessment of treatment of specific cutting effluents (KA)
- B.2.13 Provision of representative microwave equipment (AEA)
- B.2.14 Manufacturing of measuring system for representative alpha-beta isotopes; software development adapted to detectors (BAI).

B.3. Adaptation of tools and experiments

B.3.1. Setting up of a representative test mock-up (KfK)

B.3.2. Tool integration and testing (All)

B.4. Data evaluation

B.4.1. Evaluation of test results concerning EMIR (KfK)

B.4.2. Evaluation of test results concerning mechanical tools (KA)

B.4.3. Microwave data evaluation (AEA)

B.4.4. Measuring system qualification (BAI)

B.4.5. Final evaluation and recommendations including specific data on costs, work time and occupational exposure and estimates of secondary waste arisings (All).

C. PROGRESS OF WORK AND OBTAINED RESULTS

Summary

Within 1990, the basic concept investigation B.1.1. - B.1.12. started and the integration parameters of all partners to the EMIR system were defined. The discussed basic concept was agreed at the first milestone meeting, end of February 1991.

Progress and results

KfK activities: EMIR has been equipped with a wrist, which replaces the arm 5. This wrist carries a flange plate to allow the attachment of tools and sensors. For the decommissioning work, it was agreed to construct a tool exchange system of two plates A and B; the A-plate attached to the EMIR wrist, the B-plates carrying the various tools and measuring devices (B.1.1., B.1.2.). Figure 1 shows the overall working capacity of EMIR.

KA will construct the plates and take care of the couplings beside their tool development. Various tools have been taken into account but core drill, chisel and hydraulic cutter are considered to be installed (B.1.4., B.1.5.).

AEA-microwave system was defined and introduced with its needs for demonstration in the free field (B.1.6.).

The microwave device consists of a large box (1600 x 900 x 800 mm) containing the magnetron, the circulator and the necessary electronic equipment. Attached to this box is a z-shape waveguide with a shroud that directs the microwave at the concrete (see Figure 2).

The input power of the microwave device will be 80 kW.

The output power is adjustable from 5 to 60 kW.

BAI contamination measurement device will consist of an array of six detectors. Existing detector technology will be used for that purpose. Developments of new detectors are under way. If they are finished in time, they will be integrated into the system. This detector array is protected by a frame against contact with surface (B.1.7., B.1.8., B.1.10., B.1.11., B.1.12.). Definition of contaminants is still open (B.1.9.).

Test layout: A rough estimate of test parameters was discussed and agreed to demonstrate the teleoperability of tools separately from the maneuvering capabilities of EMIR (B.1.3.).

Problems: The licensing procedure for microwave health impact and atmosphere disturbances by leakage has to be started as well as the licensing to use tracers in free field conditions.

An extensive microwave monitoring seems to be necessary for personnel protection.

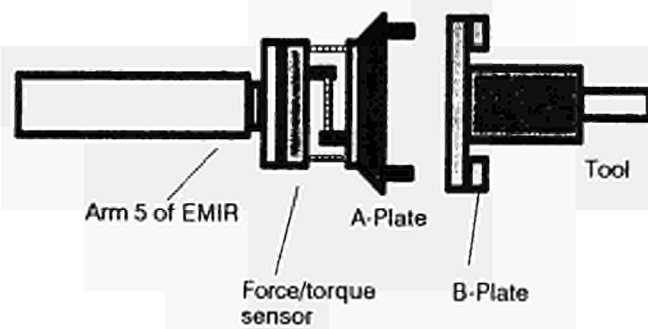
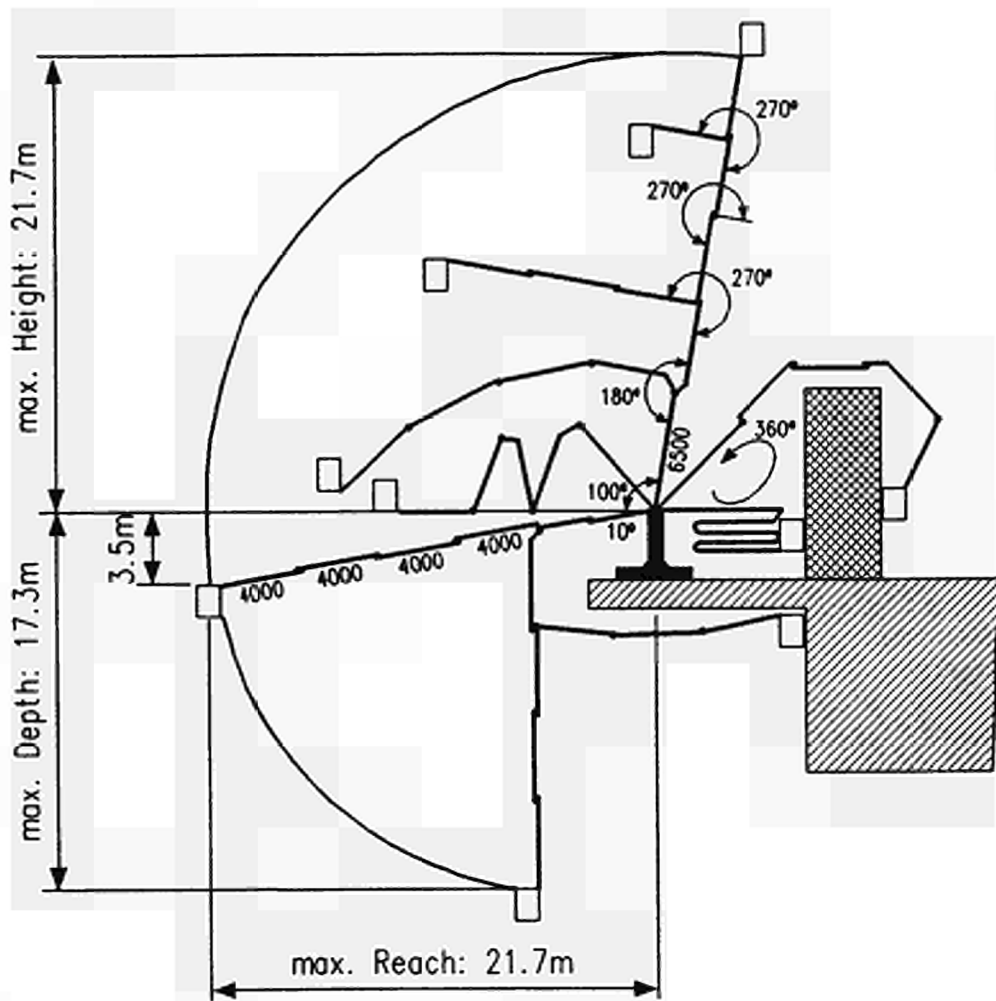

Figure 1:
Overall size of EMIR and
tool plate design

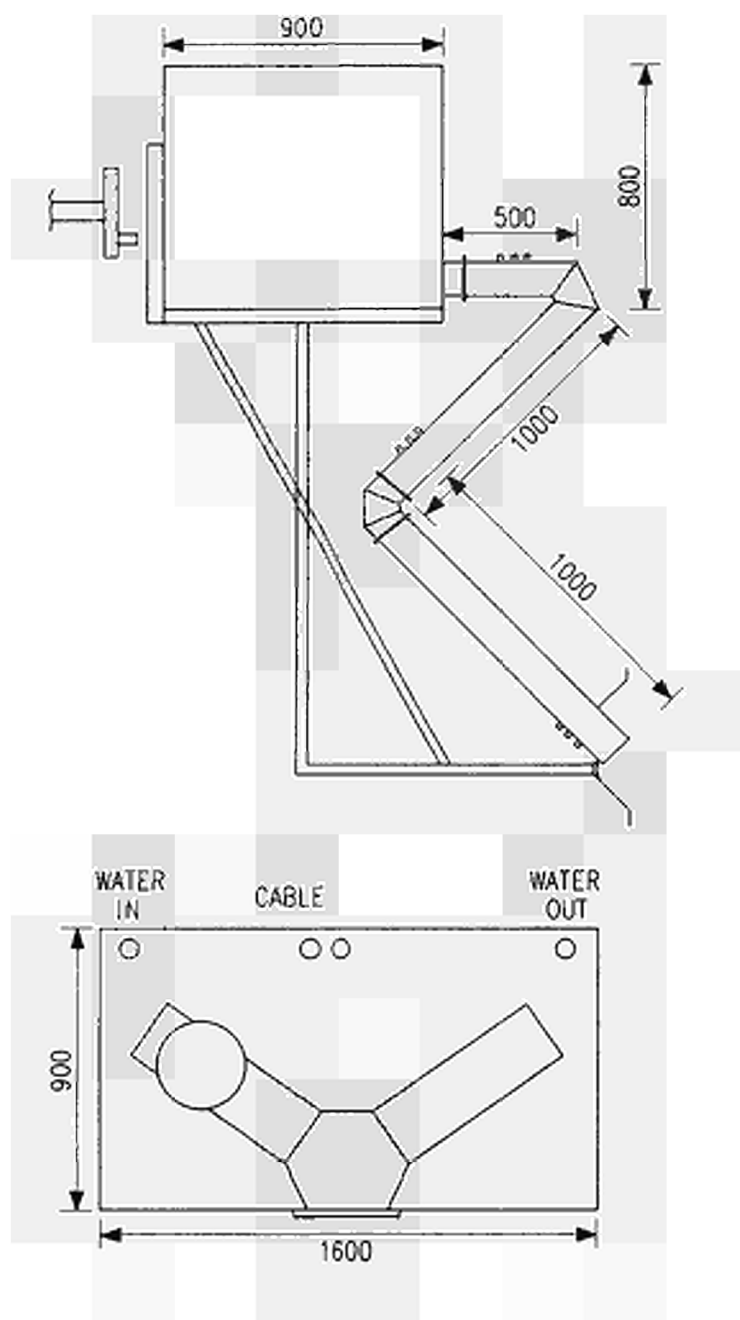

Figure 2: **AEA Micro-wave device**

5.6. UNDERWATER QUALIFICATION OF RD 500 MANIPULATOR

Contractors: CEA FAR, Framatome, TNO Delft
Contract No.: FI2D-0041
Work Period: October 1990 - January 1993
Coordinator: G CLEMENT, CEA/DTA/UR, CEN/FAR
Phone: 33/1/46 54 91 16 Fax: 33/1/46 54 02 36

A. OBJECTIVE AND SCOPE

The work concerns industrial-scale underwater experimentation in non-radioactive conditions of the RD 500 prototype telemanipulation system, which has been already extensively tested in air with various tools. The typical nuclear dismantling environment concerned is a LWR vessel and fuel storage pool.

The objectives are:

- Adaptation of the existing RD 500 manipulator for underwater dismantling tasks;
- Assessment of the capability of the RD 500 manipulator to operate under water with various tools;
- Underwater qualification and performance assessment of a new ultrasonic imaging system;
- Qualification of the complete system by an in-field application and definition of an industrial underwater RD 500 system.

The research work will assess the feasibility of underwater dismantling operations, the performance of the computer-assisted modes of control and the assumption that the RD 500 system can be more effective than hands-on work in relevant decommissioning environment.

The CEA will coordinate the research work. Subsidiary companies of the CEA and Framatome (SNE La Calhène and ATEA) will perform specific technical adaptations on the RD 500 systems and the underwater qualification tests.

B. WORK PROGRAMME

B.1. Identification of underwater requirements and specification to be done on the RD 500 and the vision system.

- B.1.1. Identification of relevant underwater tasks (CEA).
- B.1.2. Selection of appropriate tooling systems (plasma arc, abrasive disc, electro-erosion) (CEA).
- B.1.3. Definition of test mock-ups on which the tooling will be operated (Framatome, CEA).
- B.1.4. Specification of the auxiliary test equipment (Framatome).
- B.1.5. Specification of RD 500 adaptations, with particular view to its water-tightness (CEA).
- B.1.6. Specification of the optical vision systems (TNO, CEA).
- B.1.7. Drafting of a qualification procedure document based on relevant cutting operations (CEA).

B.2. Preparation of the preliminary tests in air and under water; the basic hardware and software will be developed/adapted, manufactured and assembled

- B.2.1. Study, manufacturing and shop test of adaptation of tooling selected in B.1.2. (Fr. + CEA)
- B.2.2. Design and manufacturing of RD 500 adaptations; preliminary underwater tests (CEA).
- B.2.3. Vision systems acquisition, adaptations and developments (TNO, CEA).
- B.2.4. Manufacturing of the auxiliary test equipment (Framatome).

B.3. Preliminary testing of the complete system

- B.3.1. Individual air and underwater testing at each partner's laboratory (All).
- B.3.2. Installation of simplified test mock-ups for main sub-system testing in air (Fr. + CEA).
- B.3.3. Main sub-systems testing (Framatome, CEA).
- B.3.4. Implementation of improvements (All).

B.4. Underwater qualification tests

- B.4.1. Installation of the various equipments in a water pool at ATEA/Framatome (Framatome).
- B.4.2. Operational verifications of the complete system (All).
- B.4.3. Performance of the qualification tests as defined in B.1.7. (Framatome)

B.5. Final evaluation and specifications with respect to conditions in real dismantling projects; evaluation of the costs of an industrial RD 500 system and of its radiological impact on work force and working area (All).

C. PROGRESS OF WORK AND OBTAINED RESULTS

Summary of main issues

The period was devoted to the review of the possible dismantling task and to the identification and analysis of the tasks which would best demonstrate and evaluate the capabilities of the RD500 manipulator system.

Progress and results

1. Identification of underwater requirements and specifications to be done on the RD500 and the wition system (B.1.)

FRAMATOME company has selected the electroerosion process in the context of the removal of a welded key securing the bolts that maintain heavy plates constituting PWR boiler internals. In this framework, the RD500 manipulator will demonstrate its ability to carry and position the tool in front of the welded key. Master-slave as well as automatic modes of controlling the arm will be evaluated in order to identify the most effective and fast combination to achieve the task. The operations will be performed with the help of video and ultrasonic feedbacks.

The electroerosion process requires to very accurately position and hold the tool head during operation. This constraint cannot be fulfilled when the tool is directly handled by the manipulator. This is due to the flexibility of the arm supports (amplifying vibrations) and the actual accuracy positioning limit of this type of manipulator. Consequently, a particular technique will be developed to render the process locally independent from the manipulator (the tool will be pressed by the manipulator on the support plate in order to bypass the vibrations). This technique may become generic and will be applicable to operate similar toolings.

CEA has selected two other underwater processes which correspond to the type of tools which are of common use in the decommissioning activities. These are the plasma torch and the disk grinding tool. The operation of these tools will address the evaluation of some other capabilities of the RD500 manipulator.

The first tool is a plasma torch underwater cutting head. The interests to consider plasma are numerous:

- the direct handling by the operator - in manual "master-slave" mode - of a plasma torch is very difficult. The operator is unable to perform acceptable work mainly because the accuracy and the regularity of the manually generated movements are poor, one needs some assistance in order to stabilize the motion and the speed of the torch, especially when segmenting thick metallic plates. The programme will consequently implement and evaluate the effectiveness of the computer-assisted teleoperation mode available in the control system of the RD500 manipulator;
- the visual control of the plasma segmentation process is difficult because of the arc illumination (blinding the cameras) and the production of gas bubbles. The computer assistance is one approach to overcome the problem (automatic movement generation and control), however the visual aid is still not available. To overcome this difficulty the programme will evaluate the help that can be provided by ultrasonic imaging techniques.

The second tool selected by CEA is a disk grinding machine which underwater test will address the field of geometric assistance (in order not to jam the disk) and the operation of heavy and strongly vibrating tools.

TNO has started the analysis of the task envisaged by CEA and FRAMATOME and their surrounding environment in order to define the required characteristics of the ultrasonic system. The nature of the work scene is different from past experience in the field of offshore applications, an adaptation study is necessary.

FRAMATOME has started with CEA the analysis of the implementation of the whole system on an experimental work site in the pool of ATEA company in Nantes.

6. AREA No. 6: ESTIMATION OF THE QUANTITIES OF RADIOACTIVE WASTE ARISING FROM DECOMMISSIONING OF NUCLEAR INSTALLATIONS IN THE COMMUNITY

A. Objective

The low-level radioactive waste produced in the dismantling of nuclear installations will ultimately constitute a substantial part of the overall volume of radioactive waste generated by nuclear industry. The objective of this area is to estimate the quantities of various categories of radioactive waste that will arise from the decommissioning of nuclear installations in the Community. This involves the definition of reference strategies for decommissioning and is therefore to be regarded as a long-term task.

B. Subjects of the research performed under the previous programmes (1979-88)

Research has been performed in the following main areas:

- estimate of the quantities of radioactive waste arising from the decommissioning of typical nuclear installations, based on analysis of radioactive metal and concrete samples;
- study of strategies for the decommissioning of typical nuclear installations and for the conditioning/management of the radioactive waste arising therefrom;
- characterisation of the radioactivity associated with components and structures of various nuclear installations, with emphasis on long-lived radionuclides; in situ measurement techniques for the localisation and identification of radionuclides, including the case of mixtures of alpha, beta and gamma emitters;
- assessment of residual activity levels below which activated and/or contaminated parts could be reused and corresponding measurement methods.

C. Programme 1989 to 1993

Radioactivity measuring techniques should be improved/developed with particular regard to clearance procedures for materials, buildings and sites, including the case of mixtures of alpha, beta and gamma emitters. The quality assurance of clearance procedures should also be considered.

Strategies for the decommissioning of typical nuclear installations should be further studied, account being taken of the waste disposal facilities existing or planned in various member countries. Safety being one of the aspects to be considered, a methodology for evaluating the risk of decommissioning operations should be developed.

The evaluation of residual activity levels below which materials from decommissioning could be reused should be pursued, including consideration of statistical aspects.

D. Programme implementation

At the end of 1990, six research contracts relating to Area No. 6 were at the stage of execution and three contracts were at the stage of negotiation.

6.1. QUICK MEASURING METHODS OF RADIONUCLIDES IN MATERIALS AND WASTES DURING DECOMMISSIONING OF NUCLEAR INSTALLATIONS

Contractors: TÜV-SWD, FHGF
Contract No.: FI2D-0033
Work Period: September 1990 - December 1993
Coordinator: L DIERKES, TÜV, Mannheim
Phone: 49/621/395 530 Fax: 49/621/395 299

A. OBJECTIVE AND SCOPE

Under the ALARA guidelines of the German Radiological Protection Ordinance, it is necessary to know the exact amount of radioactivity and the radiological potential of the materials of installations to be decommissioned.

The objective of this work programme is to determine a correlation between the gamma and beta emitters (electron capture nuclides) by analysing the activation products and contaminants in reactor materials and in waste products. These informations are essential for determining the radioactivity released to the environment and for radiological protection of the public and the personnel.

The extracted material (e.g. iron) will be submitted to beta-activity measurements, followed by a gamma-activity determination. The correlation of both measuring methods should make it possible to reduce the determination of the total radioactive material quantity to gamma-spectroscopic analyses.

The work programme will be performed in contact with the Chemistry Division, Harwell Laboratory UKAEA, especially concerning the exchange of measuring methods.

B. WORK PROGRAMME

- B.1. Acquisition of instrumentation (TÜV-SWD)**
- B.2. Choice and procurement of representative samples from the reactors MZFR, FR2, KNK and/or KWO (TÜV-SWD)**
- B.3. Laboratory activities, reference measurements and correlation calculations for nuclear determinations on decommissioning wastes (all)**
- B.4. Evaluation and documentation of the results (TÜV-SWD)**

C. PROGRESS OF WORK AND OBTAINED RESULTS

Progress and results

1. **Acquisition of instrumentation** (B.1.)

A coaxial Ge-detector with high resolution spectrometer and a low-level proportional counter are installed and are now working.

2. **Choice and procurement of representative samples** (B.2.)

Calibration procedures of photo-emitting nuclides and efficiency measurements are carried out. The low-level proportional counter is calibrated with Beta-emitting sources.

3. **Laboratory activities** (B.3.)

For the identification and separation of radionuclides (especially electron capture nuclides), a wet chemical separation procedure will be developed.

6.2. RADIOLOGICAL ASPECTS OF RECYCLING CONCRETE DEBRIS FROM DISMANTLING OF NUCLEAR INSTALLATIONS

Contractors: TÜV-Bay., RWE
Contract No.: FI2D-0039
Work Period: November 1990 - December 1993
Coordinator: F J SCHMID, TÜV-Bay.
Phone: 49/89/5791 1470 Fax: 49/89/5791 1551

A. OBJECTIVE AND SCOPE

Limiting values for the release of concrete with low-level residual radioactivity for the selective undangerous utilisation (e.g. for noise barriers, earth fill, earth bank or substitute for foundation material) are presently not defined. The research programme will examine whether it is possible to define limiting values for radioactively contaminated concrete in the range of the limiting values for steel. The effect of radioactively contaminated concrete on the soil (leach out of radionuclides) and on man (radiation exposure) will be determined.

The results of these studies will have an effect on the decommissioning activities as far as buildings of the controlled area and the kind and quantity of the radioactively contaminated concrete are concerned.

The advantage of the studies lies in an economic and safe recycling of large amounts of concrete with a low-level artificial residual radioactivity. Thereby, valuable ground storage space would be saved and natural gravel deposits would be preserved.

The research work will provide data concerning cost saving by recycling concrete from controlled areas, radiation exposure of the decommissioning workers and of the general public.

The research programme is performed in co-operation with CEA-IPSN, which has a research programme with a similar objective (see § 6.4.).

B. WORK PROGRAMME

B.1. Leach tests

- B.1.1. Design of the test facility and determination of concrete test specimen. (all)
- B.1.2. Construction and operation of the test facility. (TÜV-Bay.)
- B.1.3. Literature survey on leaching out problems of radionuclides in concrete. (TÜV-Bay.)
- B.1.4. Radiological measurements on concrete rubble before, during and after leach out tests. (TÜV-Bay.)

B.2. Natural radioactivity in concrete

- B.2.1. Procurement of samples from recently produced and aged concrete. (RWE)
- B.2.2. Measurement of alpha, beta and gamma radiation. (TÜV-Bay.)
- B.2.3. Literature survey concerning the natural radioactivity of concrete.

B.3. Development of methods for recycling concrete.

- B.3.1. Examination of concrete recycling possibilities by a literature study. (RWE)

B.4. Calculation of radiation exposure and determination of the artificial residual radioactivity

- B.4.1. Determination of radiation exposure scenarios. (TÜV-Bay.)
- B.4.2. Calculation of radiation exposure for man due to natural and artificial radioactivity. (TÜV-Bay.)
- B.4.3. Derivation of criteria for the safe use of concrete with artificial radioactivity. (TÜV-Bay.)

C. PROGRESS OF WORK AND OBTAINED RESULTS

Summary of main issues

Due to the late transfer of the research contract, the work programme started not earlier than November 90.

In November/December, the following activities were carried out:

- planning of the test facility for the leach tests;
- procurement of approximately 15 (out of 50) samples of aged concrete from conventional buildings and approximately 15 (out of 50) samples of recently produced concrete;
- preparation of the measurement of alpha, beta and gamma radiation.

Progress and results

1. Design of the test facility and determination of concrete test specimen (B.1.1.)

The layout of the six containers for the concrete test specimen and of the sprinkler system for the tests were planned (Figure 1). The amount of water for imitating the rain was defined as a precipitation of 1,000 mm per year. Using a time-lapse effect, the time for affecting the concrete by rain is reduced from 20 years to 20 months. 5 test specimen will be sprayed with 1,000 mm of water every month. The sixth test specimen is constantly under water.

The test facility is under construction at the moment. It will be installed in the turbine hall of the shut down nuclear power plant of Gundremmingen, unit A.

2. Procurement of samples from recently produced and aged concrete (B.2.1.)

In 1990, approximately 15 samples of recently produced concrete and aged concrete were collected in the state of Bavaria (FRG). At the moment, the remaining samples are being collected in various states of the Federal Republic of Germany.

3. Measurement of alpha, beta and gamma radiation (B.2.2.)

The preparations for the measurement of alpha, beta and gamma radiation will be carried out. The measurements will start early in 1991.

The research programme proceeds according to the schedule.

Figure 1 : Test facility for leach tests

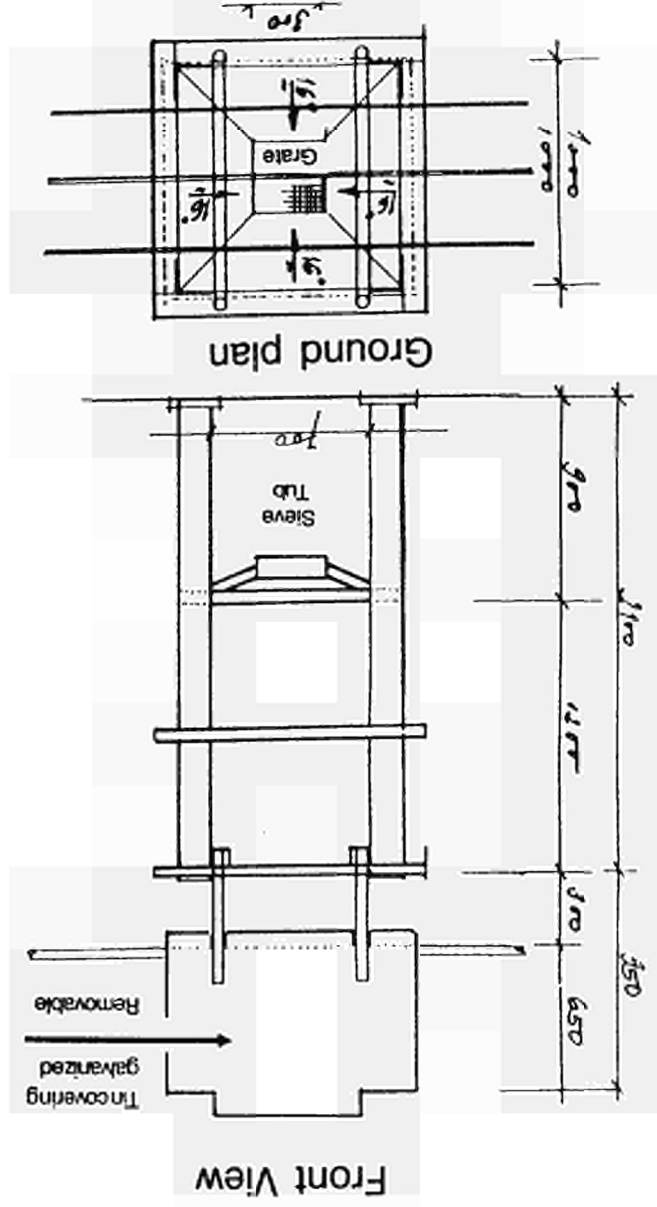
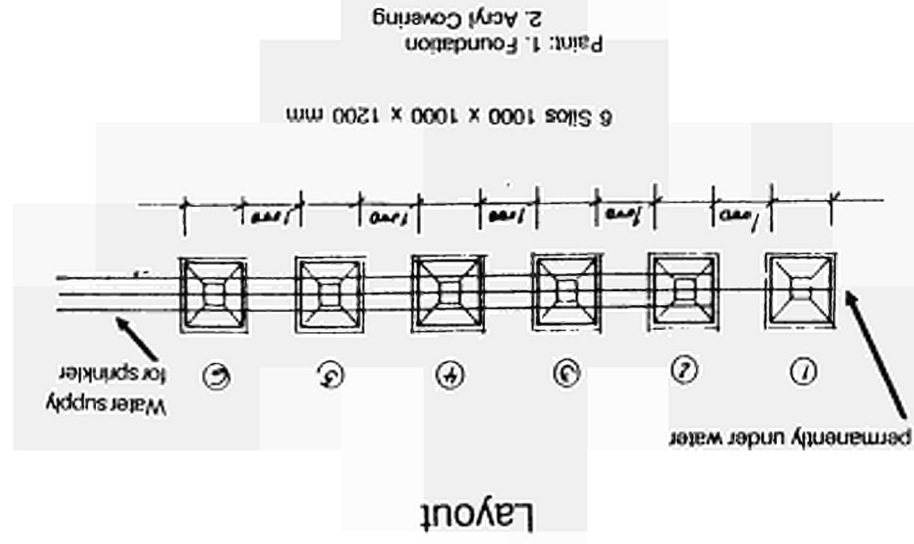

6.3. METHODOLOGY TO EVALUATE THE RISKS OF DECOMMISSIONING OPERATIONS ON NUCLEAR PLANTS

Contractors: AEA-Culch., NRPB, AEA-Wind.
Contract No.: FI2D-0030
Work Period: October 1990 - September 1992
Coordinator: G C MEGGITT, AEA-Culch.
Phone: 44/925/25 42 24 Fax: 44/925/25 45 44

A. OBJECTIVE AND SCOPE

The theoretical work is composed of two distinct but complementary studies:

- a) **Waste management options:** The theoretical study continues to develop an existing methodology to aid decommissioning waste management decisions, and to demonstrate the improved methodology by applying it to the prototype AGR Windscale reactor decommissioning waste for which the final management option has not yet been chosen. The main extension to the existing methodology (see final report on contract FI1D-0051 is to enable the incorporation of risks and uncertainties, rather than simply doses and environmental impact parameters. The improved methodology, like the existing one, will be applicable to decisions concerning the decommissioning of all types of nuclear reactors and could lead to reductions in radiation risks and financial costs, as well as promoting consistency between the approaches in various countries;
- b) **Decommissioning strategies:** The work will aim at developing a comprehensive methodology to evaluate radiological risks to the public and workers from decommissioning of non-reactor nuclear plants. Such a methodology will allow the comparison of different decommissioning strategies from a risk point of view so that the benefits associated with, for example, delay in decommissioning to more advanced stages could be assessed.

B. WORK PROGRAMME

- B.1.a. **Development of a radiological risk evaluation methodology (NRPB) considering the uncertainties in models and modelling parameters.**
- B.2.a. **Selection of the waste stream for an example application of the methodology (AEA)**
- B.3.a. **Definition of the radionuclides inventory and their distribution in the selected waste stream (AEA)**
- B.4.a. **Definition of waste management options (AEA)**
- B.5.a. **Estimation of financial costs for each of the management options. (AEA)**
- B.6.a. **Calculation of doses and risks for individuals and the public. (NRPB)**
- B.7.a. **Assessment of social and environmental impacts of waste management options. (NRPB)**
- B.8.a. **Demonstration of the methodology by identifying the optimal management options. (NRPB)**
- B.9.a. **Review of the results and check of their applicability to other decommissioning decisions. (all)**
- B.1.b. **Definition of decommissioning phases of non-reactor nuclear plants. (AEA-Culch. for the entire b-study)**
- B.2.b. **Identification of techniques for carrying out decommissioning operations and their risk-bearing elements.**
- B.3.b. **Identification of risk assessment procedures taking into account normal and possible accidental risks.**
- B.4.b. **Evaluation of procedures for assessing the risks associated with leaving the plant under care and maintenance;**
- B.5.b. **Examination of methods for the aggregation of risks associated with particular decommissioning strategies.**
- B.6.b. **Demonstration of the identified methodologies to a non-reactor facility.**
- B.7.b. **Final evaluation on the suitability and limitations of the identified methodologies.**

C. Progress of Work and Obtained Results

Summary of main issues

The contract was issued in November 1990 and the work undertaken by AEA in the calendar year was restricted to the preliminary definition of relevant stages and factors.

The other Contractors were not programmed to start until first Quarter 1991.

Progress and Results

1. Definition of decommissioning phases (B.1b)

The three decommissioning stages defined by IAEA have been taken as the basis for the project. They are, as defined for land-based reactors: storage with surveillance, restricted site release and unrestricted site use. It has become apparent that these categories are rather broad for the practical purposes of the project and Stage 1 has therefore been subdivided into a further 3 stages:

1A - Removal of active working material

1B - Decontamination to levels suitable for surveillance

1C - Decontamination to levels suitable for alternative active use

It is recognised that the 1C to some extent overlaps with Stage 2. It has been found important to make distinctions between:

Operations which are extensions of normal operations.

Operations which have been conducted as maintenance operations.

Operations which are not normally conducted.

Risks associated with the intended operations.

Risks associated with the plant not being in the expected state.

- The second of these is particularly important in decommissioning where information may be incorrect or incomplete and areas of plant are entered which may have been unmonitored for a long period.

Plant which has been shut-down after normal operation.

Plant which has been shut-down after an accident.

Accidental hazards.

Routine radiological hazards.

Hazards associated with hardware failures.

Hazards associated with faulty management procedures.

Operations which must be performed promptly.

Operations which can be delayed.

These preliminary classifications will be elaborated as a range of non-reactor plant decommissioning is considered.

6.4 DEFINITION OF REFERENCE LEVELS FOR EXEMPTION OF CONCRETE COMING FROM DISMANTLING

Contractors: CEA-FAR
Contract No.: FI2D-0040
Work Period: October 1990 - September 1992
Coordinator: Mr D. HARISTOY, CEA/IPSN/DPEI/SERGD, Fontenay-aux-Roses
Phone: 33/1/46 54 71 56 Fax: 33/1/47 35 14 23

A. OBJECTIVE AND SCOPE

The objective of the study is to propose activity limits below which very slightly radioactive concrete arising from nuclear facility dismantling could be treated in conventional industry, or slightly contaminated buildings could be reused or decommissioned.

The study is based on the evaluation of concerned concrete quantities and allows the identification of groups of people exposed to radiation hazards. From the evaluation of individual radiological risk, the derived limits for exemption of concrete will be deduced. The study is also meant to participate in the harmonisation of criteria and rules between countries of the European Community. Potential benefits in determining such limits are:

- limitation of the decontamination time and operations, i.e. decontamination and disposal costs;
- recycling of valuable material to preserve natural resources;

The research programme is performed in co-operation with TÜV Bayern and RWE (contract N° FI2D-0039), into which CEA-IPSN will bring in the following information: natural radioactivity in concrete; work programme and results of each period; results of other French experiments connected with the subject.

B. WORK PROGRAMME

B.1. Data collection

- B.1.1. Estimation of contaminated and activated concrete quantities.
- B.1.2. Identification of radionuclides spectra and activity levels.
- B.1.3. Estimation of concrete quantity which is recycled or disposed off.
- B.1.4. Determination of the state of the art to identify the critical group of workers and public.
- B.1.5. Investigations on the possibilities of exposure of the public to different concrete by-products.
- B.1.6. Dust measurements and analysis in different crushing stations.

B.2. Treatment of information and modelling.

- B.2.1. Collection and evaluation of parameters for the different by-product pathways.
- B.2.2. Modelling of the different realistic exposure situations for critical groups.

B.3. Calculation of the radiological impact using the collected parameters during the inquiries

B.4. Determination of the activity limits for each radionuclide on classes of them.

C. PROGRESS OF WORK AND OBTAINED RESULTS

Progress and results

Data Collection (B.1.)

1) **Determination of the state of the art to identify the critical group of workers and public (B.1.4.)**

Our inquiries into the civil engineering workers in France, shows that there are two kinds of concrete crushing installations.

The big one, with a capacity greater than 200,000 metric tons, is constituted by two crushers, several riddles and produces different qualities of aggregates.

The second one, with a capacity of 120,000 metric tons or more, could move from site to site. From the economical point of view, the transfer is made if there is a crushing capacity allowing three month of work.

2) **Investigations on the possibilities of exposure of the public to different concrete by-products (B.1.5.)**

In France, at the present time, concrete by-products are essentially used in civil engineering works, as aggregates mixed with cement in road basements or landing-strips, or without additive in lanes or carriage drives.

In the construction industry, the quality of the aggregates limits their use to by-products for manufacturing of building blocks.

6.5. DOSES DUE TO THE REUSE OF VERY SLIGHTLY RADIOACTIVE STEEL

Contractors: CEA-FAR, BS, SIEMENS BEW
Contract No.: FI2D-0031
Work Period: September 1990 - February 1993
Coordinator: Mrs H GARBAY, CEA-IPSN, Fontenay-aux-Roses
Phone: 33/1/46 54 73 41 Fax: 33/1/47 35 14 23

A. OBJECTIVE AND SCOPE

The scope of the study is the determination of doses due to the reuse or recycling of very slightly contaminated radioactive steel in case of mechanical and thermo-mechanical treatments applied to scrap when exempted from regulations.

The study will mainly be based on already available data both in the nuclear field and in the conventional scrap industry. Experimental investigations will be performed, as far as possible, on radioactive samples coming from nuclear installations being dismantled. The different treatments applied to scrap before its melting have not yet been studied and are of great interest. In particular, techniques used in scrapyards should be studied in the view of inhalation and external exposure injuries.

This study applies to a large quantity of steel arising from dismantling of nuclear installations (EUR 10052).

Benefits are expected as regards management and cost of radioactive waste arisings, protection still being secured. The results concerning contamination dispersion during cutting of scrap will be useful for the evaluation of future large-scale decommissioning operations.

B. WORK PROGRAMME

- B.1. Discussion and documentation of the present regulatory situation. (BS-CEA)**
- B.2. Performance of steel cutting and aerosol sampling experiments observing industrial conditions. (CEA-Siemens)**
- B.3. Evaluation of inhalation risk in realistic situations. (all)**
- B.4. Determination of the radiological impact based either on bibliographic data or on experimental results. (BS-CEA)**
- B.5. Development of a stochastic programme to obtain the individual dose distribution. (BS)**

C. PROGRESS OF WORK AND OBTAINED RESULTS

This progress report applies to the work done from september 1990 to december 1990.

The work performed by CEA was mainly bibliographic studies and collection of information on scrap recovery plants. Bibliographic studies were focused on the study of scrap market and on dust emission during cutting processes. Results were mainly obtained on oxygen cutting, dust concentration ranges from 4 mg.m^{-3} to 28 mg.m^{-3} ; experiments have been made on different types of steel (special steel, painted or not, various scraps of carbon steel and stainless steel, thick ingot). The average dust concentration for each type of steel is ranging from 8 mg.m^{-3} to 15 mg.m^{-3} (B1).

A scrap recovery plant has been visited, which uses a 900 tonnes scrap shearing in an open air area. It operates the cutting of concrete reinforcement bars and of metal girders. The cutting of concrete reinforcement bars is dusty, this dust comes mainly from remaining concrete; the cutting of metal girders is less dusty, this dust comes mainly from the rust. An agreement has been established for a measurement campaign in this plant (B1-B2).

The work performed by Brenk Systemplanung started with a survey of industrial exposure conditions for the cutting of slightly contaminated steel scrap. For alpha-emitters inhalation of aerosols produced by the cutting operations is the dominant pathway. The survey, therefore, was primarily directed to an assessment of the important parameters for the various cutting techniques employed in industry (B1).

In the lung models of ICRP the particle size of incorporated aerosols is considered as an important parameter. In order to deal with this factor of influence a formalism was developed that is capable introducing the particle sizes into the dose calculations (B3).

On the basis of this work first steps for the modeling of the radiation exposure have been taken.

The work performed by Siemens applied to characterization and treatment of scrap from the uranium processing division of the Siemens nuclear fuel fabrication facility in Hanau. By experience the following average scrap composition is known: ferritic steel : 85%; austenitic steel : 15%. The applied reduction techniques are the following: mechanical methods are sawing with a hacksaw and compass-saw, reduction using plate shears, compacting using hydraulic presses; the thermal method is oxy-acetylene cutting.

According to the work program, it is intended to divide the tasks into the following steps:

- Preparation of metallic scrap items with an alpha-activity in the range of about $0.05 - 10 \text{ Bq/cm}^2$. For the determination of the alpha-activity, the surfaces have to be as smooth as possible.
- Determination of the surface alpha-activity.
- Characterization of the material in terms of composition and surface roughness.
- Determination of the smearable proportion of the activity.
- Performance of the reduction operations with simultaneous sampling of alpha-aerosols for the determination of the released total quantity of alpha-active aerosols as well as the determination of relation between aerosol alpha-activity and the average particle size.
- Determination of the alpha-activity of aerosol samples using a suitable proportional counter (B1-B2).

6.6. QUANTIFICATION OF ACTIVITY LEVELS AND OPTIMISATION OF DOSE RATE MANAGEMENT TO PREPARE STAGE 3 DECOMMISSIONING OF GAS-COOLED REACTORS

Contractors: CEA-VALRHÔ, Radia
Contract No.: FI2D-0044
Work Period: October 1990 - September 1993
Coordinator: J R COSTES, CEA/DCC/UDIN, Bagnols-sur-Cèze
Phone: 33/66 79 13 Fax: 33/66 79 64 32

A. OBJECTIVE AND SCOPE

As part of the preparatory work for Stage 3 decommissioning of the G2/G3 gas-cooled reactors at Marcoule, the project involves:

- quantifying the activity levels of complex core structures based on theoretical analysis and on a large number of dose rate measurements;
- design of a software package to optimise the dismantling and related operations and best minimising of the dose rates incurred by the personnel.

It is important to determine the dose rates and time necessary on each manual dismantling operation, and to assess the material activity levels for optimum waste conditioning and disposal.

The development of suitable software tools and thorough examination of all the possible scenarios are very time-consuming undertakings requiring aid beyond national boundaries.

B. WORK PROGRAMME

- B.1. Dose rate measurements and analyses of core samples after a literature review (CEA).
- B.2. Analyses of geometric, physical and radiological data (Radia)
- B.3. Development of a computer programme to calculate gamma-activity levels in the entire core (Radia)
- B.4. Development of a computer programme to minimise dose rates during human interventions (CEA)
- B.5. Comparison of calculated and measured results (CEA).
- B.6. Examination of dismantling scenarios (CEA).
- B.7. Revision of expert software considering decommissioning time and doses (CEA).
- B.8. Evaluation of costs, radioactive job doses, working time and secondary waste arisings (All).

C. PROGRESS OF WORK AND OBTAINED RESULTS

No significant work was performed in this just starting contract.

7. SECTION C: TESTING OF NEW TECHNIQUES IN PRACTICE

A. Objective

The objective of this research is the assessment of new decommissioning techniques under real conditions of radioactivity, configuration, size, accessibility and state of components after long-term operation. Section C is focused on four outstanding pilot dismantling projects (WAGR in Windscale, BR-3 PWR in Mol, KRB-A BWR in Gundremmingen, AT-1 FBR fuel reprocessing facility in La Hague), but also includes alternative large-scale tests in nuclear installations other than the pilot projects.

Occupational radiation exposure and specific costs for typical unit operations, are important aspects to be considered besides technical assessment.

Work in the pilot projects should be complemented by large-scale testing of appropriate techniques proposed by other contractors from Member States.

B. Subjects of the research performed under the previous programmes (1979-88)

Large-scale investigations on various decommissioning techniques (such as decontamination, cutting, activity measurements) were performed in the 1984-88 decommissioning programme. These investigations concerned the dismantling of five reactors, three fuel fabrication facilities and one high-level waste vitrification facility.

C. Programme 1989 to 1993

Section C should include:

- the execution of four pilot dismantling projects
- alternative large-scale tests to be performed in nuclear installations other than the pilot dismantling projects.

Here are included other nuclear reactors and other installations of the nuclear fuel cycle having representative value for important upcoming decommissioning tasks in the EC, such as for fuel fabrication facilities, for fuel reprocessing plants and waste treatment facilities.

- secondment of scientific staff from Member States to the pilot dismantling projects.
The owners of pilot projects will receive staff from Member States for active cooperation within the framework of the project.
- large scale testing within the framework of the pilot dismantling projects of appropriate new techniques and procedures developed elsewhere in the Member States.
The possibility of accepting such demonstration tests on the components of the dismantling site is provided in the contracts concluded with the owners of pilot projects.

D. Programme implementation

At the end of 1990, thirteen research contracts relating to Section C were at the stage of execution and two contracts were at the stage of negotiation.

7.1. PILOT DISMANTLING OF THE WAGR. PHASE 1: DISMANTLING OF TOP BIOSHIELD REFUELLING STANDPIPES, VESSEL TOP DOME; TRIALS OF REMOTE DISMANTLING SYSTEM

Contractors: AEA-Wind.
Contract No.: FI2D-0001
Work Period: October 1989 - September 1992
Coordinator: T BOORMAN, AEA
Phone: 44/9467/72410 Fax: 44/9467/28986

A. OBJECTIVE AND SCOPE

The Windscale Advanced Gas-cooled Reactor (WAGR) had a capacity of 33 MWe and was operated from 1962 to 1981. Dismantling of the plant has started and is planned to be completed in 1996.

Considering that the experience to be gained from the dismantling of the first large-scale nuclear installations in the Community should be made available to all Member States, the Commission selected WAGR as a pilot dismantling project for the 1989-93 R&D programme on the decommissioning of nuclear installations. The Commission, through shared-cost participation in specific parts of the project, is promoting the use of advanced techniques and the performance of collateral investigations, in order to enhance the production of useful knowledge and experience to serve in subsequent decommissioning tasks. In particular, the generation of specific data on costs, working hours and job doses as well as on the amount of created secondary waste is an important objective of this project.

As a gas-cooled reactor, WAGR provides opportunities for testing decommissioning techniques against the specific requirements of such reactors, which represent the majority of the first-generation nuclear power reactors to be decommissioned in the Community in the near future. The present contract involves in particular the dismantling of the top biological shield, of refuelling standpipes and of the reactor pressure vessel top dome as well as inactive trials of the remote dismantling machine.

The estimated radioactive inventory is in the order of 10^5 Ci; estimated dose rates are in the range of 0,1 to 1,5 mSv/h.

B. WORK PROGRAMME

- B.1. Dismantling of the top biological shield (TBS), a 60 t disc-shaped steel and concrete structure, by thermic lancing after its moving into a ventilated containment placed on the refuelling floor.**
- B.2. Cutting and handling of the refuelling standpipes, i.e. 253 pipes of 6.3 m length penetrating the upper part of the reactor block, by four cuts, with an internally rotating plasma arc torch.**
- B.3. Cutting and dismantling of the pressure vessel top dome, a complex steel structure of 6.5 m diameter and 98 mm maximum thickness, by in-situ segmentation in two parts using a semi-remote operated oxy-gas cutter placed on a tractor followed by post-segmenting in a temporary containment placed on the refuelling floor.**
- B.4. Inactive trials of the remote dismantling system, comprising a rotating floor shield, an extendable mast carrying a telemanipulator arm, and a remotely operated conveying system, in a test facility representing a 30° sector of the reactor pressure vessel.**
- B.5. Generation of specific data on costs, radioactive job doses, working time and secondary waste arisings, derived from the execution of items B.1., B.2. and B.3.**

C. Progress of Work and Results Obtained

Summary of main issues

The reactor top biological shield was successfully removed from its recess in the refuelling floor by using hydraulic jacks attached to the gantry of the refuelling machine which had been retained for this purpose and was size-reduced for disposal as low-level waste using the thermic lancing process.

Refuelling standpipes (247) have been cut in three locations, using a family of internal plasma torch tools, to permit removal of the top bioshield and as part of the operation to release the reactor pressure vessel top dome. These operations will continue until all sections of the standpipe are removed.

The top dome of the reactor pressure vessel has been freed of all attachments and a circumferential cut has been made around the crown section using a tracked oxy-propane torch. Heavy duty flexible membranes have been attached to maintain containment when it is separated from the reactor.

A facility has been designed, to be constructed inside the reactor containment building, in which the remote dismantling system can be tested and the operations team trained in its use. Construction of the facility had to be postponed because of the methodology adopted for top dome dismantling.

Progress and Results

1. Dismantling of the top biological shield (TBS)

When this operation was planned initially the intention was to cut the structure, in-situ over the reactor, into six pieces which would then be light enough to be lifted by the building 25 tonne crane and small enough to negotiate the route out of the building. A fundamental objection to this approach was that debris from cutting would fall onto the reactor and possibly into the refuelling branches. Whilst the refuelling machine was being dismantled its gantry section was identified as a suitable platform from which to lift out the TBS whole. A specialist lifting contractor was engaged for this operation. Four synchronised 20 tonne hydro-mechanical jacks were fitted on beams running transversely across the gantry from which tie-bars were passed through four of the shutter tubes in the TBS. Supported in this manner the TBS was lifted as shown in Figure 1 and removed to an area prepared for the size-reduction operation.

Diamond cutting techniques, core drilling and wire sawing were the obvious choices for size reduction but the composition of the TBS, 50/50 steel to concrete by weight, resulted in a high degree of uncertainty regarding the time required. Thermic lancing was considered for size reduction as the high content worked to the advantage of the process. The disadvantage of this process is that it produces large amounts of fume. For this reason a temporary containment was built around the TBS to prevent the spread of any small amounts of contamination but more particularly to contain the fume generated when cutting, shown in Figure 2. Extract ventilation was provided by two $0.5 \text{ m}^3 \cdot \text{s}^{-1}$ HEPA filters using Electrostatic Precipitators as pre-filters. A $1 \text{ m}^3 \cdot \text{s}^{-1}$ air mover with a bag filter was used in a recirculating leg to improve working conditions.

The cutting process lasted fifteen working days with cutting occupying only three hours of each day. A total of 280 seven metre long lances were consumed to cut a cross sectional area of approximately 5.6 m^2 . The total mass of waste produced was 52 tonnes which was disposed of as low-level waste, dose uptake to operators was not raised above that for general operations.

The adoption of this methodology has proved very successful both in terms of minimising dose uptake, maintaining project timescales and demonstrating the use of standard industrial techniques in reactor dismantling.

2. Cutting and handling of the refuelling standpipes

The reactor was served by 247 refuelling standpipes which are being progressively cut and removed. Four vertical locations for cutting have currently been identified; just below the top biological shield, directly above the top dome, just inside the top dome and directly above the hot box of the reactor. An industrial water-cooled plasma arc cutting torch was adapted to use gas cooling and optimised to for minimum fume generation using a plasma gas of Argon with 5% Hydrogen. This torch is incorporated into a family of tools for internally cutting the standpipes. In all cases the tool is lowered from above the reactor into the standpipe.

The standpipes have an internal diameter of 143 mm and a wall thickness of 7 mm. Contamination on their inner surfaces results in a radiation dose of 20 $\mu\text{Sv.h}^{-1}$. Background dose from the reactor pressure vessel varied as the operations progressed. Prior to Top Bio-shield removal radiation levels in the general work area were very low at $\mu\text{Sv.hr}^{-1}$, following its removal radiation level rose to 5 $\mu\text{Sv.hr}^{-1}$ but planning estimates for standpipes cutting operations after removal of the top dome assume the value then to be 150 $\mu\text{Sv.hr}^{-1}$. Three phases of standpipe cutting have now been completed. Phase one using the plasma torch on an extension tube with a motor driven panning motion cut just below the Top Biological shield to enable its removal. Phase two used a modification to the original tool producing a cut above the Top Dome. For this operation the tool was deployed from a scaffolding platform erected across top top of the reactor vault. During this phase a combined torch and pipe grab was tested which will be used for later operations. Following phase two a temporary floor was erected across the top of the reactor vault and from this phase three cutting detached the standpipes from the inside of the Top Dome. The plasma torch tool for this operation incorporated a mechanical sensor to located the correct position of the cut, shown in Figure 3, and this operation was followed by a video inspection of the cut tube.

Dose uptake and waste arising for these operations is given below.

Table 1: Summary of dose uptake

Phase	1	2	3
Dose man mSv	3.6	7.4	7.1

The average activity on each standpipe was 0.14 GBq with a specific activity of 1.46 GBq.te⁻¹.

Table 2: Summary of waste quantities

Phase	1	2	3
number of cuts	247	247	247
weight of waste item	22 kg	75 kg	0
Total weight	55 te	18.5 te	0

The standpipe cutting technique has been developed and shown to be very successful during these early low dose operation. The future standpipe cutting operations following removal of the pressure vessel top dome will be planned with much tighter estimation and control of dose uptake.

3. Dismantling the pressure vessel top dome

The Top Dome is the upper hemispherical end of the steel reactor pressure vessel, approximately 70 mm thick. Six independent pressure loop tubes and the 247 standpipes pass through the crown section which is thickened to 98 mm. The weight of this structure is approximately 45 tonnes. It is not activated but is contaminated to 370 Bq/cm² and radiation levels at its inside surface from other reactor components are estimated to be in the order of 4 mSv.hr⁻¹. The original method of removal proposed was to cut it into sections small enough to remove through 1 m² openings in the temporary floor. Dose budgets showed this method to be impractical as operators would spend a large proportion of their time in the high radiator zone created as each section was removed. An alternative strategy has been formulated, this is to remove the top dome in two large pieces, the crown and the remaining plain section using a bulk posting technique to maintain the containment of the reactor and vault. Table 3 below summarised the results from the dose estimates for the two methods.

Table 3: Summary of estimates for dose uptake

Dose	Method 1	Method 2
Total man(mSv)	178	58
Highest individual (mSv)	32	5.4

This operation has begun with a tracked oxy-propane cutter being used to cut around the six loop tubes and completely around the crown section as shown in Figure 4. A series of studs have been welded adjacent to the cut edge and also along the lip of the vault to provide attachment points for the sealing membrane which is sufficiently baggy to permit the top dome to be lifted clear of the vault. The specially designed heavy duty plastic membrane has been attached between the edge of the crown section and the edge of the reactor vault. As this section is removed from the reactor vault the membrane can be tied off thus ensuring that containment of the reactor will be maintained.

A test lift of this part of the structure using the building crane has indicated a weight of 28.5 tonnes. Dose uptake for the cutting operations was 0.94 man.mSv compared with 0.87 man.mSv estimated for this part of the operation which gives confidence in the values calculated for the subsequent operations.

4. Inactive trials of the remote dismantling machine

Inactive trials of the WAGR remote dismantling system are to be carried out in a test facility to be constructed adjacent to the reactor bioshield. The position of the test facility has been chosen such that the Remote Dismantling Machine can be lifted out whole and positioned over the reactor on completion of the trials. With the design of the test facility for the remote dismantling system now complete, negotiations are currently in progress with selected contractors for its construction.

A change to the programme this task had been necessary as discussed

below. The methodology developed for the removal of the pressure vessel top dome requires a large area, at refuelling floor level, in the range of the overhead crane. The only suitable area is that to be occupied by the test facility. To meet this requirement construction of the test facility has been delayed.

The revised programme for the test facility resulted in a contract placed on 19 November 1990 for work to commence on site on 12 June 1991. To prevent delay to the WAGR decommissioning programme shortened contract programme has been agreed with the contractors to completed construction of the Facility in September 1991; the remote dismantling machine will be installed at that time. A testing and training schedule for the facility is being devised.

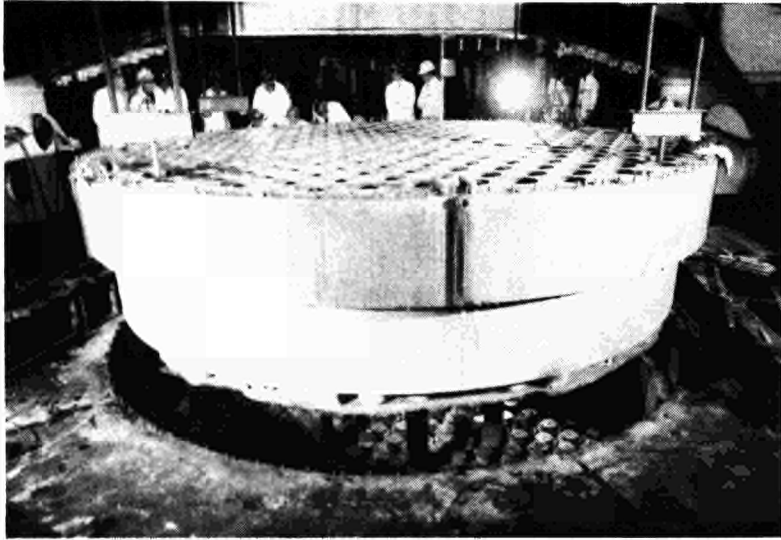

Figure 1: Lifting the Top Bioshield



Figure 2: Cutting the Top Bioshield

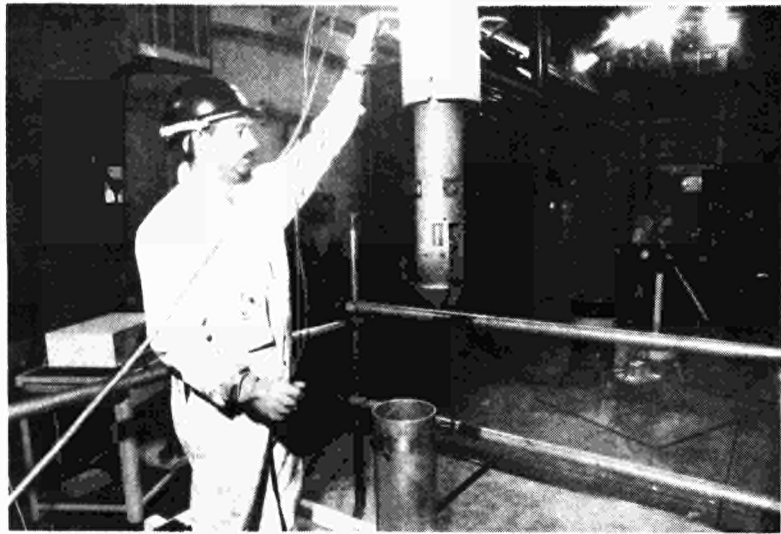

Figure 3: Phase 3 standpipe cutting tool

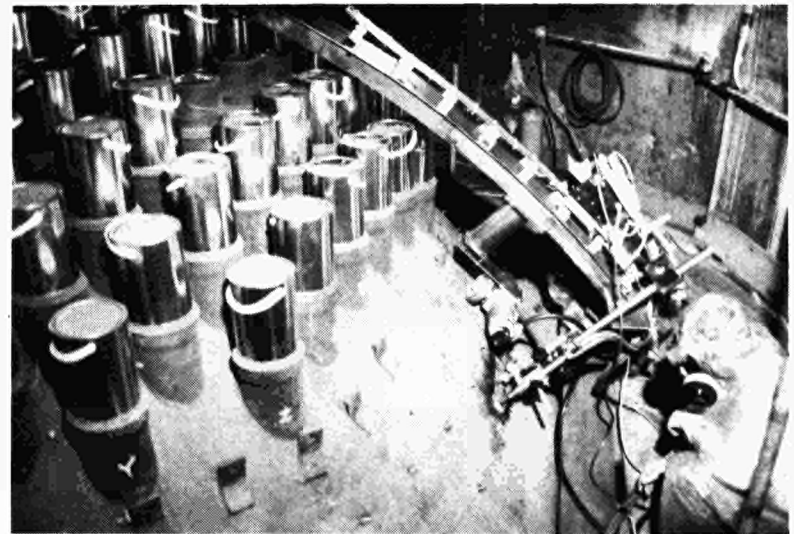

Figure 4: Cutting around the top dome

7.2. COMPARATIVE ASSESSMENT OF ALTERNATIVE UNDERWATER REMOTE OPERATION AND SEGMENTING TECHNIQUES FOR REACTOR VESSEL INTERNALS OF KRB-A

Contractors: KRB
Contract No.: FI2D-0002
Work Period: October 1989 - September 1990
Coordinator: W STANG, KRB
Phone: 49/8224/783 730 Fax: 49/8224/782 900

A. OBJECTIVE AND SCOPE

The Boiling Water Reactor plant Gundremmingen A (KRB-A) is one of the four pilot dismantling projects of the EC programme (see also § 7.5.).

The present contract is concerned by a preliminary design and assessment study of alternative remote operation and segmenting techniques for underwater dismantling of the pressure vessel internals of KRB-A. Occupational radiation exposure, costs, and the conditioning and minimisation of the radioactive waste will be considered in particular.

In the course of its implementation this study was extended to the case of the VAK BWR of Kahl.

B. WORK PROGRAMME

- B.1. **Inventory of KRB-A conditions**, e.g. materials and geometries of components, local dose rates and radioactivities, accessibility.
- B.2. **Literature study on the state-of-the-art**.
- B.3. **Analysis of underwater segmenting techniques** including thermal, mechanical, electrical and chemical techniques.
- B.4. **Investigation of remote-operation techniques** considering alternative manipulator designs and various degrees of automatisation.
- B.5. **Comparative evaluation of the alternative techniques investigated**, considering all relevant aspects; selection of the optimum technique(s); identification of experimental investigations needed, if any.

C. Progress of work and obtained results

Summary of main issues

It was the aim of the study to prepare a concept for the dismantling of the internals of the reactor pressure vessel and the vessel itself of KRB-A. This concept should base on the state of the art and should be feasible in consideration of the local circumstances. Therefore a work group was organized. This group consists of representatives of contracted companies, specialists in nuclear topics and technical staff of the nuclear power plant of Gundremmingen (KRB-A) and of the nuclear power plant of Kahl (VAK). The participation of VAK guarantees that the results will be not too specific but generally valid.

On the basis of all important data, drawings etc. of KRB-A and VAK, the contracted companies worked out different decommissioning concepts for the RPVs and their internals. Then a group of experts from KRB-A and VAK and some independent specialists evaluated the different concepts and made proposals for the further proceedings (definition of the dismantling strategy, planning of inactive tests, etc.).

At the same time a literature study on possible and generally used decommissioning techniques was accomplished and evaluated.

Progress and Results

1. Inventory of KRB-A conditions (B.1.)

On the basis of drawings, calculations and other dossiers available component lists of the RPVs and their internals were prepared. For each component or part of a component, weight, wall thickness, volume, dimensions, material, activation and contamination were noted. Furthermore handling and transportation facilities, storage areas, filtering and cleaning devices etc. were listed. These data were given to the contracted companies of the work group as basis for the planning.

In KRB-A, there is enough space at the operating platform (31,5 m) contrarily to the conditions in VAK. Furthermore the separate storage pool for fuel elements gives a significant advantage to decommissioning purposes. This pool can be used for a separate segmenting station or as storage area.

2. Dismantling techniques (B.2., B.3., B.4.)

In order to compare and to check the planned decommissioning proposals a literature study on the decommissioning of nuclear facilities and the applied techniques was accomplished. The literature sources can be divided into three main groups:

- reports about decommissioning work in nuclear facilities;
- reports about reparation work in nuclear facilities;
- reports about developments of special techniques in laboratory scale.

The big wall thicknesses, complex structures, often narrow space conditions and the high radioactivity require special cutting techniques. It must be possible to use them in atmosphere and/or under water as well as to operate them remotely controlled and in all cutting positions. Furthermore the primary and secondary cutting waste has to be captured safely. Mechanical and thermal cutting techniques are options for the application in decommissioning.

Mechanical techniques require heavy machines to handle the high restoring forces. Size and weight of the applied tools depend on the dimensions of the component to be cut. Application of mechanical cutting techniques is limited by complicated structures and narrow environment. Thermal cutting techniques cause smaller restoring forces, the handling equipment can be smaller. Therefore thermal cutting devices are generally more flexible in use. On the other hand much more secondary waste and aerosols are produced and extensive filtering and water purifying systems are necessary.

Only very few literature was found about handling and gripping techniques for decommissioning purposes. This problem seems to be neglected in case of handling pieces of scrap, so that there is no special development beside the normal handling instruments for nuclear facilities.

The development of remote handling techniques shows, that nowadays electrical master-slave manipulators are preferred to mechanically controlled manipulators. Obviously electrical controlled systems have been developed in the past and are reliable even in under water application. Electrical master-slave manipulators are quite expensive tools, but they are very flexible in their application.

For the control of the manipulators various systems are suggested in the literature. New concepts use sensors to follow the cutting path. They are mostly supported by teach-in-techniques.

3. Results of the study (B.5)

When working out the decommissioning concepts, some contracted companies of the working group had to respect not only the conditions given in the facility of KRB-A or VAK, but also specific options :

- a concept using minimal automation;
- a concept using maximal automation;
- a concept using the fuel element storage pool with a segmenting station.

The other contractors had to develop in their point of view an optimal decommissioning concept.

There were five studies related to the KRB-A decommissioning project. The main results of these studies (A to E) are listed in table I. Study A had to respect a minimal application of automated techniques, study B should concentrate on the use of the fuel element pool for a segmenting station. The studies C, D and E represent "optimal" decommissioning strategies.

All five concepts estimated about the same time requirement for the complete decommissioning of the RPV and its internals:

- | | |
|--|------------------|
| - preparation time
(development, planning etc.) | 1.3 - 2.5 years |
| - execution time | 2.2 - 3.0 years. |

In general the decommissioning work would be done with approximately 12 workers, but the resulting job dose was estimated very divergently. The minimum value is 270 mSv and the maximum is 3000 mSv! The costs were estimated between 12 and 26 million DM in total, excluded the costs for the waste disposal.

All five concepts distinguish dismantling and segmenting works; the free fuel element storage pool is always used with a separate segmenting station. Because of the different structures of the RPV and its internals in most concepts different decommissioning methods are proposed.

According to the notion of all contracted companies, the RPV internals should be dismantled and segmented under water. The plasma arc cutting technique is mostly found to be the preferable cutting technique, because only minor restoring forces will be occurring. Therefore it would be possible, to cut the RPV internals without heavy guidance and fixing machinery. Furthermore the use of master-slave-technology was estimated to offer enough flexibility to handle even complex geometries of the internals

Table I: Main data of the decommissioning concepts

	CONCEPT				
	A	B	C	D	E
total job dose [mSv]	412	3000	275	870	1000
number of workers	12	15	5-8	11	8-28
time required [y]					
preparation	1.3	1.75	2.0	2.5-3	2.3
execution	2.8	3.0	0.75	3.0	2.2
total	4.1	4.75	2.75	5.5-6	4.5
costs [Mio DM]					
hardware	4.8	6.5	2.0	13.0	14.8
personnel	7.5	13.5	0.8	13.0	6.9
total	12.3	20.0	2.8	26.0	21.7
waste [m ³]					
primary	140	-	191	233	225
secondary	7.8	-	936	113	-
total	147.8		1127	346	225

(e.g. the core support). Contrarily, concept D proposed a completely mechanical segmenting technique. Therefore a universal cutting unit was designed. This machine is able to segment not only the RPV internals but also the RPV itself.

The segmentation of the RPV wall is suggested to be done in atmosphere. consequently most concepts propose the use of mechanical cutting (sawing) to avoid production of aerosols.

The guiding of the tools is mainly done by special machines, which fit into the RPV and fix themselves to the wall by hydraulic plungers. These machines are transported by the crane and carry not only the cutting tool, but also serve as gripping device for the piece to be cut. The wall of the RPV is either segmented into rings and then transported into the fuel element storage pool for further segmentation, or it is cut into rectangular pieces in situ and then directly packed.

A proposal to maintain under water cutting of the RPV wall by installing a shirt around the RPV is being discussed. Because there is only little space between the RPV and the biological shield, all the pipes and its connection pieces have to be cut very closely to the RPV wall. The shirt has to be welded to the lower part of the RPV.

In order to find out the optimal techniques for the actual decommissioning of the RPV and its internals completeness, depth and diligent working up to the decommissioning concepts are valuated. Positive ideas and details of every concept are collected. The comparison of all proposed techniques and as well the information received by the literature study will give a good idea about the state of the art in decommissioning techniques. This will be the base to work out a feasible concept for KRB-A. Furthermore a lack of information will show up clearly and necessary inactive experiments can be defined.

7.3. PILOT DISMANTLING OF THE BR-3 PWR PHASE 1: DECONTAMINATION OF A PRIMARY CIRCUIT, REALISATION OF CUTTING EQUIPMENT, SEGMENTATION OF FIRST REACTOR INTERNALS

Contractors: SCK/CEN, Siemens-KWU, Framatome
Contract No.: FI2D-0003
Work Period: October 1989 - September 1991
Coordinator: F MOTTE, SCK/CEN
Phone: 32/14/33 21 11 Fax: 32/14/31 19 93

A. OBJECTIVE AND SCOPE

The BR-3 Pressurised Water Reactor had a capacity of 11 MWe and had been operated from 1962 to 1987. CEN/SCK has started the dismantling and decontamination of certain parts of the plant and is examining the possibility of its complete dismantling.

Considering that the experience to be gained from the dismantling of the first representative nuclear installations in the Community should be made available to all Member States, the Commission selected BR-3 as a pilot dismantling project for the 1989-93 R&D programme on the decommissioning of nuclear installations. The Commission, through shared-cost participation in specific parts of the project, intends promoting the use of advanced techniques and the performance of collateral investigations, in order to enhance the generation of useful knowledge and experience to serve in subsequent decommissioning tasks. In particular, the generation of specific data on costs, working hours and job doses as well as on the amount of created secondary waste is considered as an important objective of this project.

The assessment of techniques and procedures will be performed in collaboration with Kernkraftwerk RWE-Bayernwerk GmbH (Gundremmingen), which is decommissioning the Boiling Water Reactor KRB-A (see § 7.5) and with VAK GmbH which is decommissioning the VAK BWR (see § 7.10).

As a Pressurised Water Reactor, the BR-3 is representative of the reactor type most frequently used in the Community. In Phase 1, the contract involves the decontamination of the primary circuit of the reactor and the dismantling of the thermal shield, a highly radiating steel component (specific activity $10^8 - 10^9$ Bq/g, estimated contact dose rates $10^2 - 10^3$ Sv/h, estimated radioactive inventory $10^4 - 10^5$ Ci (at plant shut-down).

The contract is implemented in close cooperation between SCK/CEN as main contractor and Siemens-KWU (FRG) and Framatome (F) as associated contractors, with an agreement for cooperation with Belgatome.

B. WORK PROGRAMME

B.1. Chemical decontamination of the primary loop

- B.1.1. Cost benefit analysis and selection of a procedure
- B.1.2. Decontamination operation
- B.1.3. Treatment and removal of decontamination waste

B.2. Segmenting of the reactor internals

- B.2.1. Concept and design of the segmenting and remote operation equipment
- B.2.2. Manufacturing and procurement of the segmenting and remote-operating equipment
- B.2.3. Inactive testing and commissioning of the segmenting and remote operating equipment
- B.2.4. Segmenting of activated components
- B.2.5. Waste treatment and packaging

B.3. Generation of specific data on costs, radioactive job doses, working time and secondary waste arisings, derived from the execution of items B.1. and B.2.

C. Progress of work and obtained results

Summary of main issues

Chemical Decontamination of Primary Loop

Soft decon processes allowing to remove the activity by ion exchange were analysed and compared; the CORD process developed by SIEMENS was selected and tested on samples taken from the reactor system; it was concluded that a three-cycle application of the CORD process would allow a Decontamination Factor between 10 and 100 to be achieved, together with a minimization of the volume of ion exchange active resins. Preparation of the decon operation was undertaken, trying to minimize the modifications to be brought to the plant equipment.

Segmenting of Reactor Internals

The BR3 pilot dismantling project is centered on the under-water segmenting of the highly activated reactor internals with the objective of a high density packaging, evacuation and storage. During the Work Period, it is foreseen to design and construct equipment allowing to utilize three cutting methods (mechanical sawing, plasma arc torch cutting and electro-discharge machining) and to demonstrate this equipment at the occasion of the segmenting of a first reactor internal, the reactor vessel thermal shield. An important objective is a cost-benefit comparative analysis of these techniques, mainly mechanical sawing and plasma cutting, applied in the same conditions in a highly radioactive environment, radioprotection being an important aspect of this comparison.

During the reporting period, the cutting installations have been designed and constructed and the very first cold tests of this equipment were done on a mock-up of the BR3 thermal shield; in parallel, the optimization of the reactor refueling pool space occupation in which the reactor internals will be unloaded and the cutting equipment installed has been carried out together with the preparation of auxiliary devices, mainly for the evacuation of the segmented pieces; the radiological optimization of the thermal shield segmentation was also in preparation.

Progress and results

1. Chemical decontamination of the primary loop (B.1.)

The main objective of the chemical decontamination of the BR3 primary loop is to reduce the radiation dose rate in the vicinity of the low- or non-activated components of the primary loop (pipes, pumps, steam generator, etc.) and the dissemination of the surface contaminants during their dismantling.

The dismantling of the plant primary loop is not a subject of this pilot dismantling project but is intended to be executed in the framework of later BR3 plant dismantling activities. However, it is not wise to postpone for too long this decontamination operation as it implies that the primary loop in its entirety as well as its active components, the primary pumps in particular, are in a fully satisfactory operational condition.

It was decided to use a soft decontamination process using low chemical concentrations allowing to fulfil the following requirements :

- to reach a mean Decontamination Factor at least of the order of 10
- to minimize the radiation dose associated with the decon operation itself
- to concentrate the displaced contamination in a single form, active ion exchange resins with a minimum volume, not exceeding, if possible, the plant ion exchange normal capacity
- to use the plant as it is, without expensive additional equipment or modification.

From the comparative study of the decontamination processes on the market today, it was concluded that the CORD decon process (Fig. 1), developed by Siemens-KWU, was most satisfactorily fulfilling the previous requirements. As all the decon processes for PWR, CORD is first treating the surface oxide layers by oxidation, converting chromium from the insoluble CR(III) to soluble Cr(VI) state; in a second step, the surface layers are then removed by the decontamination solution, the displaced contaminants being trapped on the ion exchange resins; a third step, called the cleaning step, is devoted to the complete removal of the chemicals in solution before starting a new cyclus.

On the basis of laboratory decon tests, performed on small pieces removed from the reactor system, it was decided to apply the CORD process to the primary loop during three successive decon cycles : a three-step three-cycle process. The decon tests were performed on two types of samples taken from the reactor system; the first sample was a stainless steel internal piece of a few dm² located in the upper region of the reactor pressure vessel; the second set of samples were SS tubes which were situated during service close to the RPV; the specific surface contamination on these test samples was of the order of 1 E5 Bq/cm²; after decon test no activity removable by smear test was possible to detect.

The plant was prepared for this decon operation, the main important tasks being closing of the primary loop and maintenance of the active components, mostly pumps and valves.

The working parameters of the primary loop and of the purification system were defined :

- the primary loop will be operated at a pressure of 20 kg/cm²eff and at a temperature of (95±5)°C
- the purification system will operate at lower pressure, 5 to 6 kg/cm², and temperature (65°C).

The temperature of the primary loop will be raised to 95°C by the heat generated by running the two primary pumps and stabilized at (95±5)°C by circulating water on the secondary side of the plant steam generator, the excess calories being evacuated by exchange with tertiary external cold source water.

The total inner surface of the systems to be submitted to the decontamination process is of the order of 1000 m²; the water inventory in the primary loop and purification system is approximately 15 m .

The purification system will comprise the three BR3 operation ion exchange columns of 212 l capacity each, plus three additional SIEMENS mobile ion exchange columns of 100 l capacity : it is expected that this total capacity will allow to trap all the displaced activity.

Emptying the BR3 ion exchange columns still containing radioactive resins from the plant operation period relies since recently on a specialized evacuation container, the TN21; the availability of this container is the major cause for delaying the decontamination operation up to the beginning of 1991.

2. Segmentation of Reactor Internals (B.2.)

As it does appear that the so-called RPV-NST package method used at Shippingport, the first PWR reactor to be dismantled in the world, for the decommissioning of the reactor internals and reactor vessel is neither applicable to large commercial plants nor acceptable in Western Europe, the BR3 pilot project is dealing with the segmentation of the reactor internals with the objective of a high density packaging, evacuation and storage, trying to answer the question : "How much does it cost to carry out this job safely, with an acceptable radiation dose intake ?"

The first BR3 internal to be dismantled will be the reactor vessel Thermal Shield, a stainless steel cylinder of 76.2 mm (3 inches) wall thickness with a total height of 2432 mm; the thermal shield is the thickest and the heaviest (5.5 tons) of the reactor vessel internals. It will be segmented into forty pieces with an approximate size of (0.5 x 0.5)m and an individual weight of 150 kg.

Fig. 2 shows schematically how the three selected cutting methods [mechanical sawing, electro-discharge machining (EDM) and plasma arc torch cutting] will be applied in order to be compared; the segmentation will be done partly in-situ, it means inside the reactor vessel, as far as mechanical cutting and EDM are concerned; arc torch cutting will be performed inside a cutting chamber flooded into the plant refuelling pool, to cut into angular segments the rings separated from the thermal shield by the two first techniques.

The cutting equipment and the cutting procedure will be experimented in a highly radioactive environment, in preparation for the cutting of the other reactor internals and, later, of the reactor vessel itself.

At the end of 1990, 3.5 years after final plant shut-down, the total activity of the gamma-emitter (Co-60 mainly, Mn-54) in the whole thermal shield reaches approximately $1 \text{ E}14 \text{ Bq}$ (2600 Ci), which represents approximately half a curie per kg of stainless steel; the gamma radiation dose rate under water at the surface of the thermal shield was estimated to reach a maximum of $1 \text{ E}4 \text{ r/h}$ or 100 Sv/h.

The equipment designed and manufactured for mechanical cutting and for EDM is schematically shown on Fig. 3 in cutting position, lowered into the reactor vessel, inside the thermal shield; this equipment is composed of two main parts : - the lower part or cutting device
- the upper part or lifting device

The cutting device consists mainly of a ring which is, after centering, clamped inside the thermal shield by means of radial hydraulic pistons. Vertical positioning of this ring is accomplished by vertically adjustable tie rods. A table mounted on this ring is rotated at low speed by an electric motor/gear unit; this table is provided by a tool support for carrying the saw head which is moved in the radial direction by an hydraulic linear drive.

The design provides for remote disassembly of the saw head and for lifting of the saw head for changing the saw blade under water. Chips produced during cutting are drawn off by suction equipment and collected; the cutting operation is monitored by a TV-camera.

The electro-erosion head is designed to fit onto the support tool of the mechanical cutting saw head, both heads being therefore easily interchangeable.

The **lifting device** has two main tasks : the first one is to eliminate the own weight of the thermal shield ring to be cut to avoid the saw blade being jammed during cutting; the second one is to remove a cut ring from the reactor pressure vessel and to transfer it into the plasma arc torch cutting chamber.

This equipment has been submitted to first cutting tests on a full scale partial mock-up of the reactor pressure vessel and of the thermal shield; all the diameters and tolerances of the thermal shield mock-up are scaled 1:1; only the height is reduced to approximately 50%. The material is stainless steel identical to the composition and characteristics of the original material AISI 304. Analysis of the neutron irradiation of the thermal shield has shown that no considerable changes of the material mechanical properties are to be expected, at least not considerably affecting the cutting parameters.

The equipment designed and being manufactured for arc torch cutting of the annular rings separated from the Thermal Shield is shown on Fig. 4; this chamber flooded into the refuelling pool has been specially designed to extract and collect the secondary wastes generated in the form of gas, aerosols, suspended particles, sedimented dross, etc. during arc torch cutting.

A ring separated from the thermal shield is deposited into the chamber on a table fitted with holding devices maintaining the angular segments in position after cutting; the water level in the refuelling pool is about 2.5 meters above the ring. The conical cover of the cutting chamber is topped by an axial vertical chimney in which the torch displacement mechanism and the torch feedings are located.

The water level in the cutting chamber is kept low above the ring at the top of the cover of the cutting chamber, where pipes, check valves and suction fans allow to circulate an air flow carrying away the gas (H_2 , NO_x , ...) and the aerosols formed during cutting; the aerosols are trapped on absolute filters while the diluted gases are rejected into the plant container ventilation system.

During and after cutting, the water of the chamber is circulated by pumps into two filtering units made of coarse and fine filters and ion exchange columns, until the water quality in the chamber allows to reopen the chamber for unloading the cut segments. The larger sedimenting particles are collected by a cyclone effect into the lower part of the system where they form a cake to be evacuated as well.

In parallel with the design and construction of the arc torch cutting chamber, the optimization of the cutting parameters with the plasma torch (plasma current, torch stand-off, torch linear displacement speed, nature of the primary gas and of the secondary fluid) has been undertaken and organized in two successive series of tests :

- type 1 tests were dealing with cutting horizontal 75 mm thick stainless steel plates under a few centimeters of water. Besides the

optimization of the cutting parameters, different characterization measurements of the secondary waste produced by the process have been carried out; these measurements, in conjunction with data from the literature, have been used for dimensioning the water purification and filtration systems to be connected to the flooded chamber.

- type 2 tests are dealing with thermal shield cutting in realistic conditions : vertical thick SS plate, water depth between 0.3 and 1 m, automatic drive mechanism for the torch; this second series of tests required the construction of a special installation including a large stainless steel vessel which was installed in the machine hall of the BR3 plant; this installation will be used later in 1991 for cold testing of the complete cutting chamber which will be flooded into this vessel; a ring separated from the Thermal Shield mock-up will be segmented in these conditions, with full-scale testing of the water purification system and of the air (gas and aerosols) ventilation system.

CORD PROCESS for BR3 DECONTAMINATION
(CORD: Chemical Oxidizing Reducing Decontamination)
3 cycles (3 steps in each cycle)

1. OXIDATION STEP (Cr ³⁺ → Cr ⁶⁺)	:HMnO ₄ (permanganic acid) (0,3 g/l)
2. DECONTAMINATION STEP (dissolution of hematite)	:H ₂ C ₂ O ₄ (oxalic acid) (3 g/l)
3. CLEANING STEP	:Destruction of the excess of oxalic acid by oxidation

Low chemical concentrations
Low temperature (95°)
Contamination fixed on ion exchange beds

Figure 1

BR3 Thermal Shield Segmentation

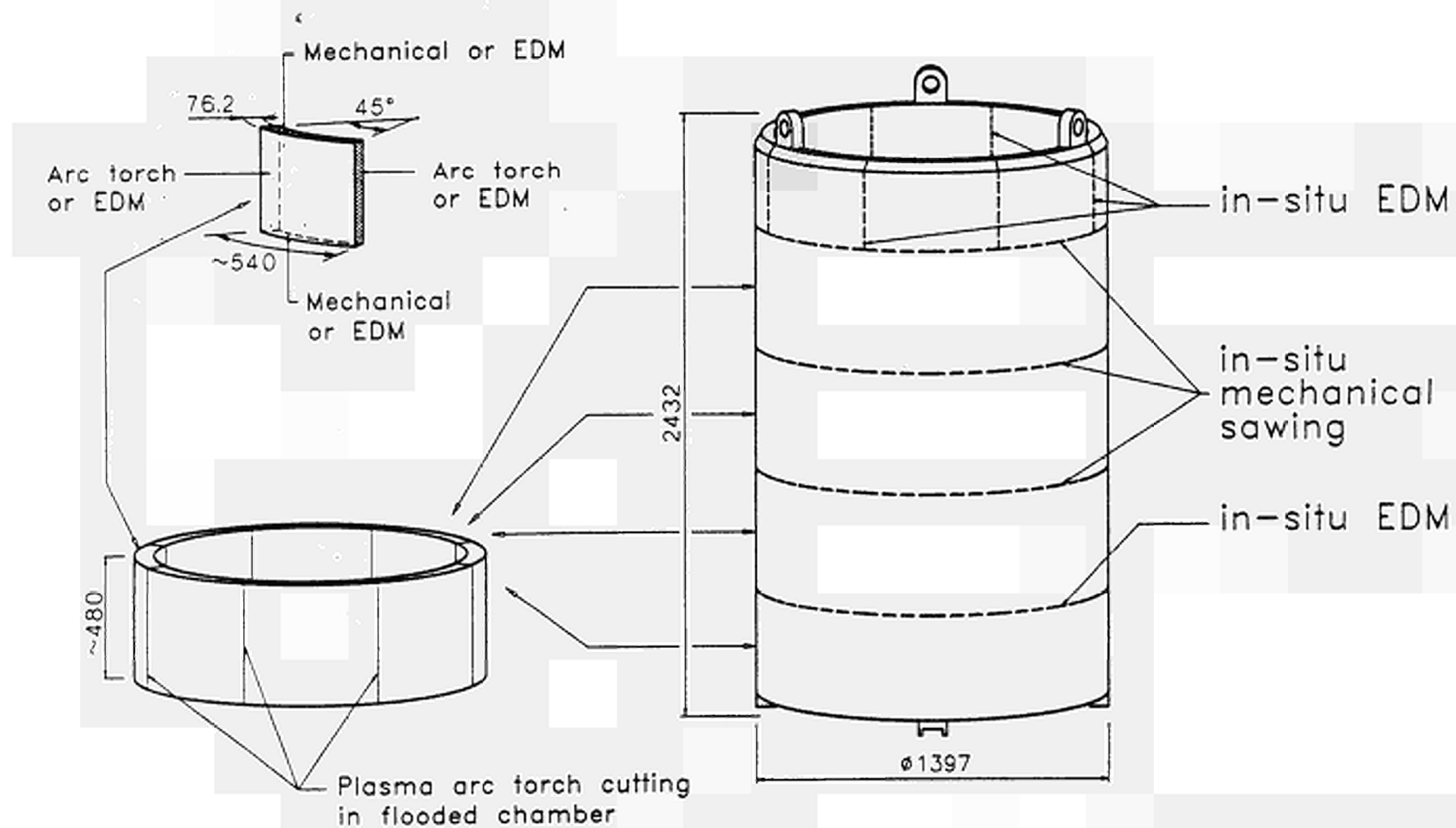

Figure 2

(All dimensions in millimeters)

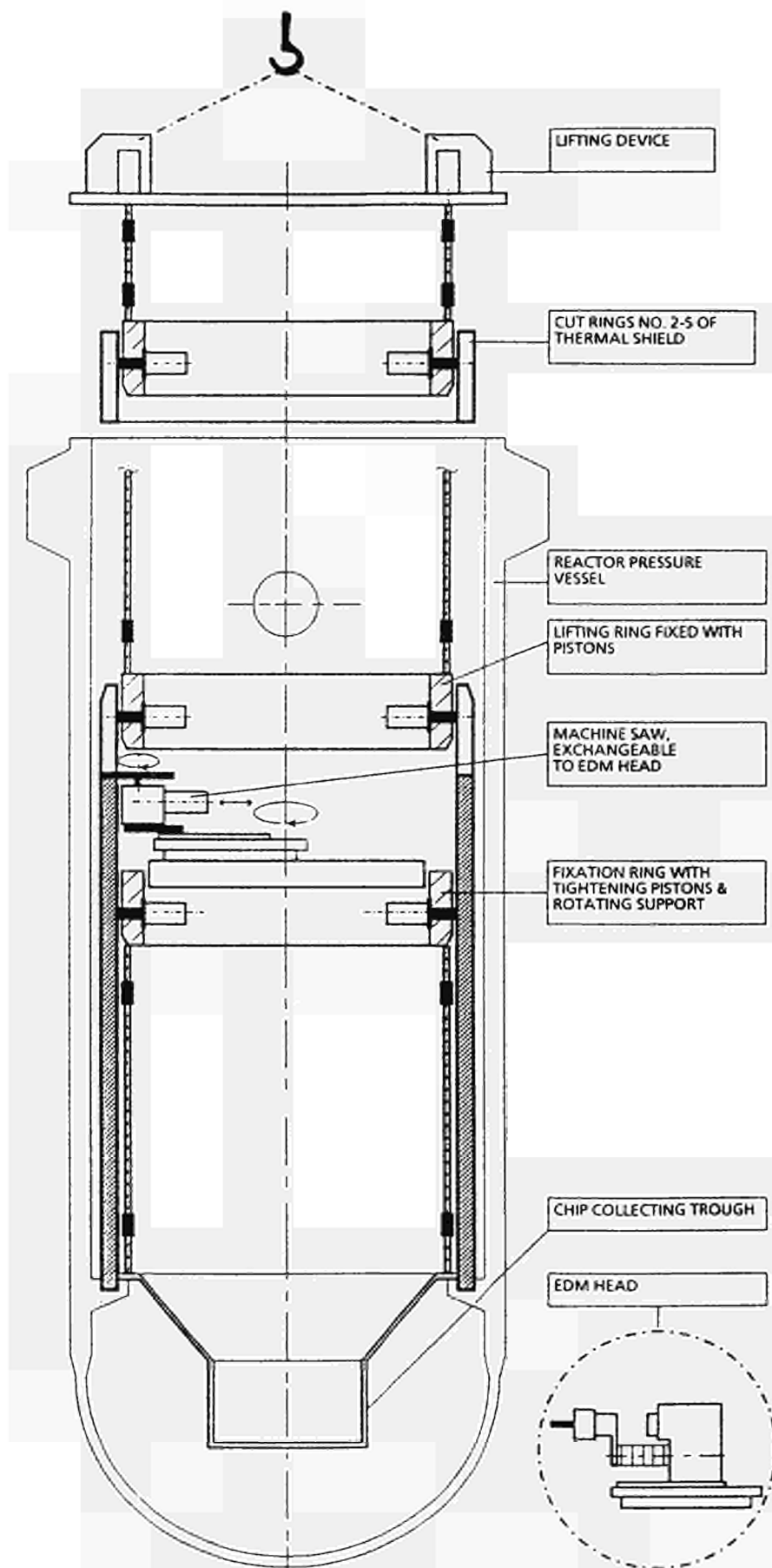

Figure 3: Mechanical cutting and EDM

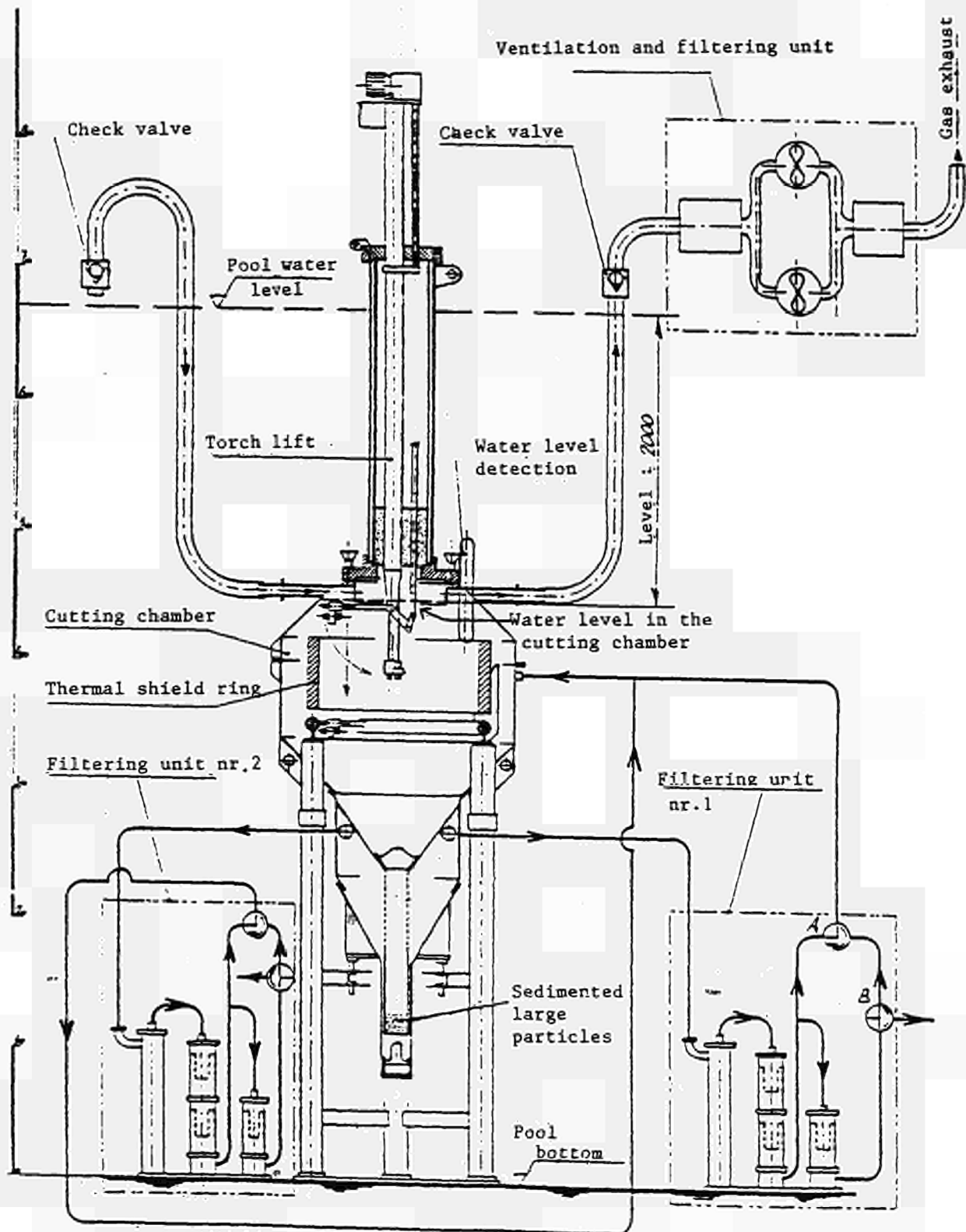

Figure 4: Arc torch cutting

7.4. PILOT DISMANTLING OF THE FBR-FUEL REPROCESSING FACILITY AT-1 PHASE 1: DISMANTLING OF DISSOLUTION AND EXTRACTION SYSTEMS AND OF FISSION PRODUCT STORAGE TANKS

Contractors: CEA-Valrhô
Contract No.: FI2D-0004
Work Period: October 1989 - September 1992
Coordinator: F CORNU, COGEMA, La Hague
Phone: 33/33 03 66 71 Fax: 33/33 03 60 14

A. OBJECTIVE AND SCOPE

The pilot facility AT-1 for the reprocessing of FBR-fuel had a capacity of 2 kg/day and had been operated from 1969 to 1979. Dismantling of the plant has started and is planned to be completed by 1992.

Considering that the experience to be gained from the dismantling of the first representative nuclear installations in the Community should be made available to all Member States, the Commission selected AT-1 as a pilot dismantling project for the 1989-93 R&D programme on the decommissioning of nuclear installations. The Commission, through shared-cost participation in specific parts of the project, intends promoting the use of advanced techniques and the performance of collateral investigations, in order to enhance the generation of useful knowledge and experience to serve in subsequent decommissioning tasks. In particular, the generation of specific data on costs, working hours and job doses as well as on the amount of created secondary waste is considered as an important objective of this project.

The dismantling of the AT-1 facility is concerned by specific problems associated to the reprocessing of irradiated fuel, namely the presence of a mixture of alpha, beta and gamma emitters. This necessitates the use of remotely operated and controlled equipment for the dismantling and decontamination, partly due to the specific conception of the cells, without direct viewing. For this, the carrier ATENA is used (telescope + polyarticulated arm) supporting the telemanipulators MA 23 or RD 500.

Specific problems are also encountered with radioactive measurements needed for the sorting and preconditioning of the arising dismantling waste. Estimated maximal values for the specific contamination and for dose rates are in the order of 10,000 Bq/cm² and 1 Gy/h, respectively.

B. WORK PROGRAMME

- B.1. Remote-operated dismantling of equipment out of the strongly contaminated cell 903 (used for dissolution), and of cells 904 and 905 (used for extraction).**
- B.2. Measurement of the radioactivity and conditioning of the waste arising from B.1.**
- B.3. Dismantling of tanks for the storage of fission products.**
- B.4. Generation of specific data on costs, radioactive job doses, working time and secondary waste arisings, derived from the execution of items B.1., B.2. and B.3.**

C - WORK PROGRESS AND RESULTS

Summary of main issues

After testing the dismantling machine ATENA and its auxiliaries were installed. Then dismantling operations started as expected in cell 905. However, as irradiation was very low in this cell it has been decided, after a short use, to transfer ATENA to cell 904 and to finish the dismantling of 905 in direct intervention.

Delay in the delivering of RD500 remote-manipulator N° 2, expected to be mounted on ATENA during the second half of 1990, resulted in a modification in the UDIN schedule. On one hand, the ATENA machine equipped with the MA23M was getting good results in the on-going operations, on the other hand, a complementary operation to couple RD500 with ATENA was necessary. It was then decided to avoid ATENA to be unavailable for 2 or 3 months, not to use RD500 coupled with ATENA but to integrate it in the waste treatment system to put it in real active conditions.

The preparation of the waste treatment cell, integrating the RD500 device was almost completed (90 %) at the end of last year.

Storage tanks for fission products have been dismantled using two processes :

- plasma torch was used to cut the tanks in the extension building (cell 920) with high contamination but no irradiation,
- linear-shaped explosive charges were used in cells 908 and 909 in the main building because of contamination and irradiation.

Progress and results

1. Remote - operated dismantling of equipment out of highly contaminated cells (B1)

The first extraction cycle is located in cell 904. Cell dimensions are : 7 m. height, 3 m. width, 6 m. length. Radioactive measurements done through penetration sleeves after shutdown of the cell and flushing (in 1981) showed "hot" points of 0,02 to 0,4Gy/h for an ambient dose rate of 0,03 to 0,04 Gy/h. A more precise mapping was carried out in July 1989 after removing the ceiling slabs of the cell, and resulted in values comprised between 0,001 and 0,05Gy/h.

Thus, it appeared necessary to identify as exactly as possible the "hot" points using the photographic gamma mapping system. Two operations were planned, the first one in November 1989 through the top of the cell and the second one in February 1990 through an opening made in the lateral corridor 802 at the bottom of the cell.

This took about 4 weeks (3 weeks were devoted to shooting). Several "hot" points were identified corresponding to the pre-cited values.

In addition, the whole of the recovery pan appeared to be more or less contaminated according to the different areas. As contamination is largely spread, total activity is high and the major part of the ambient dose rate comes from the floor.

The second and third extraction cycles are located in cell 905. Dimensions are : 7 m. height, 3 m. width, 9 m. length. Radioactive mapping carried out in July 1989, in the same conditions as in cell 904, showed values lower than 1 mGy/h.

The ATENA dismantling machine was designed for remote dismantling of the AT1 high-level cells based on the PIADF machine used to dismantle ELAN II B. It comprises a carrier and an electrically actuated telemanipulator.

The carrier includes a containment housing, a transfer lorry and a support arm with provisions for vertical motion and an articulated portion supporting the telemanipulator.

The carrier is designed to accommodate either a 20 daN MA 23 M telemanipulator or a 50 daN RD 500 telemanipulator.

The ATENA machine is located in room 800 above cells 904-905, with video control and monitoring equipment and consoles in rooms 725-728.

The lower biological shielding installed above cells 904-905 includes openings through which the carrier arm and telemanipulator can be introduced into the cell without breaking the containment integrity. Leaktightness is ensured by an obturator device set up at the selected work station. An other one provides for containment of ATENA at the maintenance station located at the South end of room 800.

Beneath the lower biological shielding, a twin-beam carriage with two hoists is used to sling heavy parts and remove waste materials. Collision prevention systems are provided on the articulated ATENA arm and on the carriage to avoid damaging them and the equipment being dismantled.

The first three months of contractual program (October - December 1989) were taken up by procurement, set up and test activities. Testing of the ATENA machine with the MA 23 M manipulator was completed. Auxiliary equipment (carriage and obturators) were received and set up on the site. The system was tested, tooling fixtures were installed in their glove boxes and the ATENA maintenance station was set up.

The first cuttings took place in January and February with the ATENA machine equipped with the remote manipulator MA23M. The purpose was to clear the top of cell 905 then to finish it in direct intervention.

ATENA was installed in cell 904 in March. Dismantling lasted less than 6 months, broke off by a short intervention in cell 905 for dismantling the mixer-settler batteries.

During the cutting operations with ATENA the wastes were dropped on the floor of the cell except for heavy parts which were removed

Wastes from cell 905 were removed during the direct intervention. Those from 904 will be removed after the start-up of the waste treatment cell (see N°2).

Shears were used for the first cuttings. The important weight of this tool (18 kg) compared with the capacity of the MA 23 led to the mounting of a weight-balance system on the take-up of the power cable to relieve the strain on the slave-arm.

Although the work was satisfactory, the use of a circular saw was then essential for its greater useability (7 kg) considering the difficult access to the cell and the shape of some of the parts to cut.

The most delicate step of the dismantling operation was the introduction of the MA23 into the cell, where the machine had to clear its way into a "jungle of pipes" choosing the right tool. Risks of collision between the poly-articulated arm out of its sheath and its environment had to be considered especially in cell 904. Difficulty was doubled because there was no direct vision of the operation, everything was carried out through a video-system. Collision however occurred proving the efficiency of the protection system of the poly-articulated arm.

The carrier was perfectly reliable. A part from a failure of the computer, occurring before the active operation - there were only a few oil leaks of no importance. After 6 months of operation the carrier was switched off for preventive maintenance.

The circular saw was much used by the remote-manipulator MA23. The main failures recorded were breaks of tape and belts and gear wear. The device went back each time to the maintenance station.

To shorten the immobilization period, a second slave arm was put in operation in June, one could then be repaired while the second was working.

The results in days of the ATENA machine operation for the dismantling of cells 905 and 904 are as follows :

	<u>905</u>	<u>904</u>
- Duration	39	95
- Active steps :		
. access and cutting	16	45
. equipment development and adjustment	3	6
- Silent steps :		
. level 1 maintenance (failures of little importance)	8	11
. level 2 maintenance (failures involving repair)	12	24
. other causes	-	9

During the considered laps of time the accumulated dose rate is as follows :

- ATENA and auxiliaries mounting and testing	: 1 mSV
- gamma photographic mapping	: 2 mSV
- 905-904 dismantling with ATENA	: <1 mSV
- direct dismantling	: 16 mSV

The dismantling of cell 905 resulted in about 6 tons of waste conditioned in vinyl protected parcels. We are presently carrying out radioactive measurements of these parcels and are storing them in containers.

2. Measurement of the radioactivity and conditioning of the waste (B2)

The high level waste treatment cell, also called "workshop cell", is located on the northern side of building 800, where the ATENA machine operates.

It is made of concrete walls and stainless-steel modular panels coming from the AT1 worksite. A part of this workshop cell is located above cell 905 allowing communication through removable slabs.

In the workshop cell, two articulated beams stuck in the wall, support 15 KN hoists allowing to reach out all parts of the cell.

The teleoperation tools include two M8 remote manipulators and the RD500 robot.

Tooling includes a circular saw and hydraulic shears hung above a mobile workplan by take-up reels.

Waste is removed by a transfer car through a hatch equipped with a hoist.

Waste from cells 904 or 903 are put in a bin then removed with a twin beam carriage to cell 905. The bin is then lifted by the 15 KN hoist of the workshop cell and tipped in the remote-manipulators area. A selection with an IF 104 probe is carried out according to the irradiation level of each waste. The wastes are cut again if necessary and placed in containers with various thickness according to their category.

The containers are removed through the waste exit hatch and transported to the measuring station.

At the end of 1990, the workshop cell was completely installed except for the exit-hatch which is in the process of being finished.

3. Dismantling of tanks for the storage of fission products (B3)

Cell 920 (extension building storage)

The tanks of cell 920 had been installed to increase the initial storage capacity of fission products solutions.

In 1986, the cell pipes were dismantled and the connections plugged by welding.

Inside remained two 30 m³ tanks (diameter : 3800, height: 3600 and thickness : 5 mm) including an internal cooling system, an homogenization pulsator, plunger-pipes for testing, input and draining of solutions.

Although this cell has never been put into operation, it was incidently contaminated during AT1 operation. The radioactive mapping carried out in 1986 showed a contamination of 100 to 4000 cps.

Decontamination of the recovery-pan and of the tanks was tempted with the hope of easing the dismantling and eventually of decommissioning the whole or part of the stainless steel. In spite of the effort, it turned out to be impossible to lower certain contamination points under 500 cps alpha on the recovery-pan then inside the tanks.

Dismantling of the tanks and the recovery-pan took place in the above-cited radiological situation with plasma torch cutting.

After cutting, a decontamination test with electro-polishing was carried out on a 1m² sample. This test proved to be satisfactory and it was then decided to apply the treatment to all the cut parts. Consequently 80 % of the metal sheets could have been decommissioned.

Cells 908-909 (main building storage)

The purpose of these cells was to store fission products solutions coming from the first extraction cycle (located in cell 904).

In both cells, there was a 15 m³ tank with an horizontal axis (diameter : 2100 mm, length : 1800 mm) and its associated pipes.

Each tank had a water cooling loop, a stirring ring with pressurized air and a vent-hole connected to a wash column located in another cell.

During shutdown operations, the fission products solutions were removed from the tanks to the UP2 facility. The tanks were then strongly rinsed and emptied.

Access to cells 908 and 909 is made from building 803 through two openings blocked by baryte bricks.

Irradiation measurements carried out in April 1989 showed ambient dose rates of about 0,25 mGy/h with hot points of 10 to 100 mGy/h.

Linear shaped explosive charges were made of lead wrapper filled with explosives.

This should be completed with a usual cutting technique with shears for small diameter pipes.

Each tank was cut in six steps totalizing 70 shooting with 1500 g of explosives. The operation has been done from December 5th to December 19th for both tanks and was very satisfactory. Prior to this, the pipes cutting took place during the month of October.

The integrated dose for all the 908 and 909 operations until December 31st was 10,2 mSV.

4. Generation of specific data (B4)

Results cited above for items B1, B2 and B3 are incomplete. A detailed analysis is under way. More information will be given in the next reports.

7.5. PILOT DISMANTLING OF THE KRB-A BWR PHASE 1: DISMANTLING OF CONTAMINATED COMPONENTS OF THE REACTOR BUILDING AND OF ACTIVATED INTERNALS OF THE REACTOR PRESSURE VESSEL

Contractors: KRB
Contract No.: FI2D-0005
Work Period: May 1990 - January 1993
Coordinator: W STANG, KRB
Phone: 49/8224/783 730 Fax: 49/8224/782 900

A. OBJECTIVE AND SCOPE

The prototype Boiling Water Reactor Gundremmingen A (KRB-A BWR) of the Kernkraftwerk RWE-Bayernwerk GmbH (KRB) had a capacity of 250 MWe and was operated from 1966 to 1977. Dismantling work has been started for some time (especially the turbine hall has been dismantled), and complete removal of the power station is foreseen to be completed by 2000. The two foregoing EC programmes have been involved by four R&D contracts in the past dismantling work on KRB-A. KRB-A dismantling is a European undertaking according to the definition of the Euratom Treaty.

Considering that the experience to be gained from the dismantling of the first representative nuclear installations in the Community should be made available to all Member States, the Commission selected KRB-A as a pilot dismantling project for the 1989-93 R&D programme on the decommissioning of nuclear installations. The Commission, through shared-cost participation in specific parts of the project, intends promoting the use of advanced techniques and the performance of collateral investigations, in order to enhance the generation of useful knowledge and experience to serve in subsequent decommissioning tasks. In particular, the generation of specific data on costs, working hours and job doses as well as on the amount of created secondary waste is considered as an important objective of this project.

The assessment of techniques and procedures will be performed in collaboration with CEN/SCK Mol and VAK-GmbH, which are decommissioning the Pressurised Water Reactor BR-3 and the VAK BWR, respectively (see § 7.3. and 7.10). The results and conclusions of the assessment work undertaken in contract FI2D-0002 (see § 7.2.) will be considered for the implementation of work in this contract.

As a BWR, KRB-A is representative for such reactors, existing elsewhere in the Community. The present contract involves the dismantling and segmenting of contaminated components of the reactor building in air (partly with subsequent decontamination), and of activated internals of the reactor pressure vessel (RPV) in remotely controlled underwater operation. Estimations of maximal values for specific contamination or activation are in the order of 4.10^4 and 10^6 Bq/cm², respectively.

B. WORK PROGRAMME

B.1. Dismantling in air of contaminated and low-activated components of the reactor building, partly with subsequent decontaminating/melting.

- B.1.1. Dismantling of a secondary steam generator with various tools (band saw, flame cutting)
- B.1.2. Dismantling of a primary circulation pump by band saw.
- B.1.3. Dismantling of a primary clean-up cooler with various tools (band saw, diamond-tipped wire saw)
- B.1.4. Dismantling of a shutdown cooler with various tools (band saw, shears, flame cutting)
- B.1.5. Dismantling of the RPV-cover by flame cutting
- B.1.6. Decontamination of segmented components by dipping technique and melting for recycling and disposal.

B.2. Underwater dismantling of activated and highly contaminated components of the RPV

B.2.1. Segmenting of the steam-dryer by various tools (shears, plasma-arc torch, consumable electric electrode torch)

B.2.2. Segmenting of the water-steam separator with the core head by various tools (saw, shears, plasma arc torch with special gripping system)

B.3. Generation of specific data on costs, radioactive job doses, working time and secondary waste arisings, derived from the execution of items B.1. and B.2.

C. Progress of work and obtained results

Summary of main issues

The aim of the work in this project is to test dismantling, cutting and decontamination techniques on contaminated and activated components of KRB-A.

The selected contaminated parts for the application of well known and new techniques are a secondary steam generator, a primary cooling pump, a primary cleanup cooler, a shut down cooler and the RPV cover. They will be dismantled and cut in air. A new cutting technique was developed for the dismantling of heat exchangers. The cutting is done with a good success under frozen conditions with a large band saw.

Highly contaminated and activated components of the RPV like steam dryer and water separator will be segmented by thermal cutting techniques (plasma arc and consumable electrode) under water by using remote controlled tools.

Progress of Work

1. Dismantling in air of contaminated and low-activated components (B.1.)

1.1 Dismantling of a secondary steam generator (B.1.1.; B.1.4.)

Three secondary steam generators have to be dismantled in-situ, inside of the loop rooms, because a transport of the complete components out of their installation places is not possible. It was decided to apply a new cutting technique for the in-situ segmenting of such a large component.

Following the strategy of KRB to apply in air only cutting techniques with low aerosol production, it was recommended to execute the segmenting of these components under frozen conditions by using a large mobile band saw (max. cutting diameter 2.2 m, weight appr. 8000 kg). For this purpose the heat exchanger will be filled with water and cooled down.

There are some significant advantages by using this cutting technique:

- the dose rate in the loop room will be reduced at least by a factor of four
- the tube bundles and other internals will be fixed for the subsequent sawing
- the saw blade will be cooled without the necessity of using other cooling fluids.

At first, a preliminary test with an inactive test model was carried out in order to prove the feasibility of this technique. For the test, a large shell with a diameter of 1.5 m and a wall thickness of 40 mm enclosing a heat exchanger bundle was filled with water to simulate the conditions in a scale nearly 1 : 1. Afterwards an insulating casing was used to cover the test model. By blowing cold air, produced by a commercial refrigerator, under the insulating casing the water in the test model began to freeze from the outside to the inside. After nearly four weeks, the temperature in the center of the model comes to - 14 °C and the cutting test could be started. The changing of the temperature during cooling is shown in figure 1.

Then the cooling and insulating system was removed. The horizontally operating band saw was fixed to the model in order to cut off slices of the shell. Three blocks have been cut without any problems.

Important parameters such as cutting velocity and feed rate have been investigated and optimized. The first cut could be done within 80 minutes. By increasing the feed rate, it was possible to cut the third block within 50 minutes.

Figure 2 indicates the increase of the temperature during sawing. Furthermore the problems of lifting the parts and the displacement of the saw could be studied. This tech-

nique will be applied also to the shut down cooler in the beginning of 1991. This cooler is relatively small (diameter of 1.1 m) and has a dose rate up to 4000 $\mu\text{Sv/h}$ at the surface.

1.2 Dismantling of the RPV cover (B.1.5)

The planning for the segmenting of the RPV-cover (figure 3) is now finished. It was decided to dismantle the cover partially at first by thermal cutting techniques inside the reactor building into three pieces to allow a transport through the narrow lock gate to the turbine hall. There the cutting into small pieces will take place in a special cell with a venting and aerosol filtration system.

Borings at the RPV cover indicated that the ferritic base material is not activated. Subsequent radioactivity investigations had to find out whether the austenitic cladding is contaminated or activated.

Further dismantling by applying different cutting techniques will make it possible to compare the cutting methods concerning costs, aerosol release and man dose. It is intended to test flame cutting, plasma cutting, oxy-arc cutting and sawing.

2. Underwater dismantling of activated and highly contaminated components of the RPV (B.2.)

It is foreseen in the frame of the research contract to dismantle the steam dryer and the water separator as examples for activated components. The steam dryer is already dis-mounted and placed in its storage pool, where it was placed in former times during the changing of the nuclear fuel. The position of the steam dryer inside the reactor pressure vessel is shown in figure 4. It is situated on top of the water separator, which will be dismantled in the next stage of the work.

Figure 5 gives some details about the design of the steam dryer. This component has a diameter of about 3.4 m and a total height of nearly 4 m. The outer shielding is made out of a 5 mm material. The vertical tubes at the inside of the dryer are placed on a ring, so that they are quite close together. This fact causes a dismantling from the outside to the inside of the steam dryer.

The tubes have various sizes between a diameter of 88 mm with a wall thickness of 2 mm and a diameter of 40 mm with a wall thickness of 4 mm.

For the cutting of this component an inactive model was constructed and installed at the University of Hannover. The cutting concept includes the cutting of the shielding with plasma arc under water. The tubes will be cut with consumable electrode with water jet. This technique allows the cutting of tubes from one side.

Figure 6 gives a side view of the cutting system, as it will be used in the storage pool of the steam dryer. The cutting will be done with a special equipment which is placed on a platform. The guiding of the tool carrier is adapted to the diameter of the dryer, so that it is simple to cut windows in the shell of the steam dryer in order to cut the tubes afterwards.

At the moment, this cutting system is under construction and testing at Hannover. The correct function will be checked there. After the permission of the authority and after a training of the KRB staff at the equipment, the transport to Gundremmingen will take place.

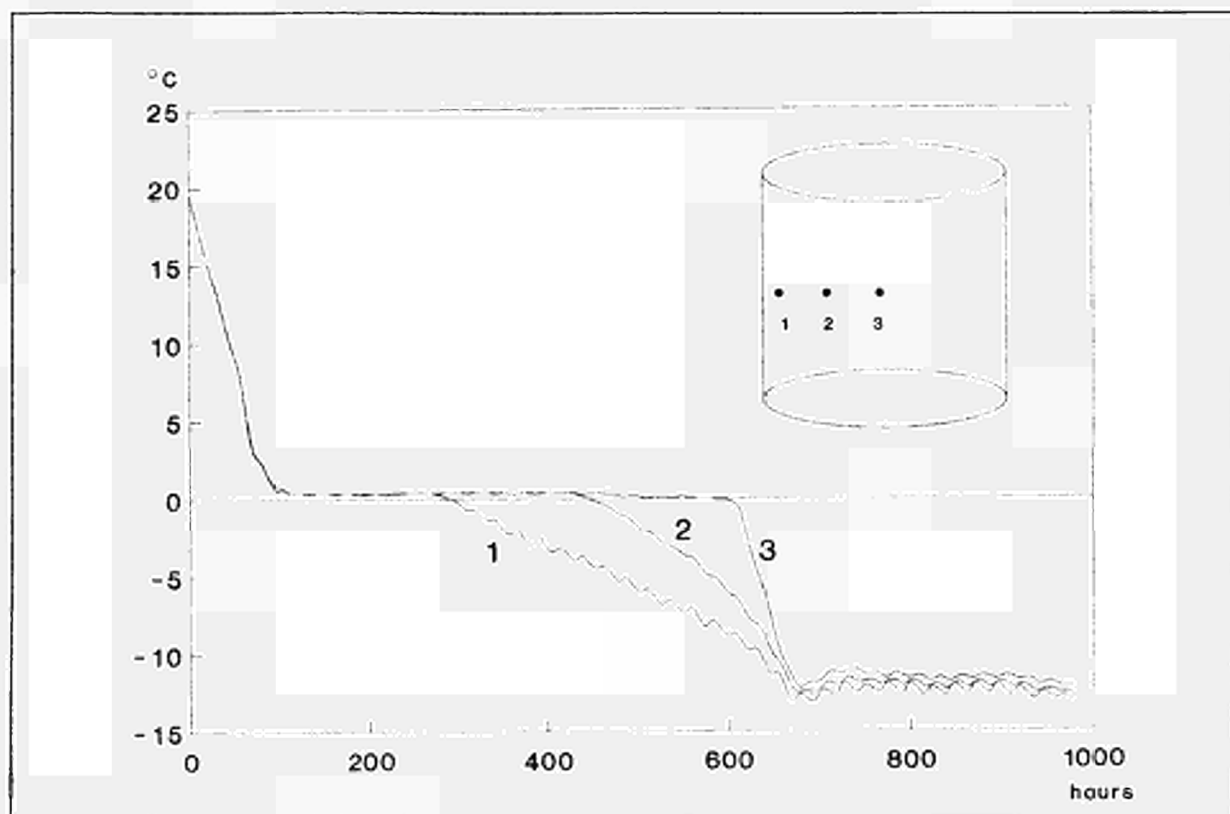

Figure 1: changing of the temperature during cooling

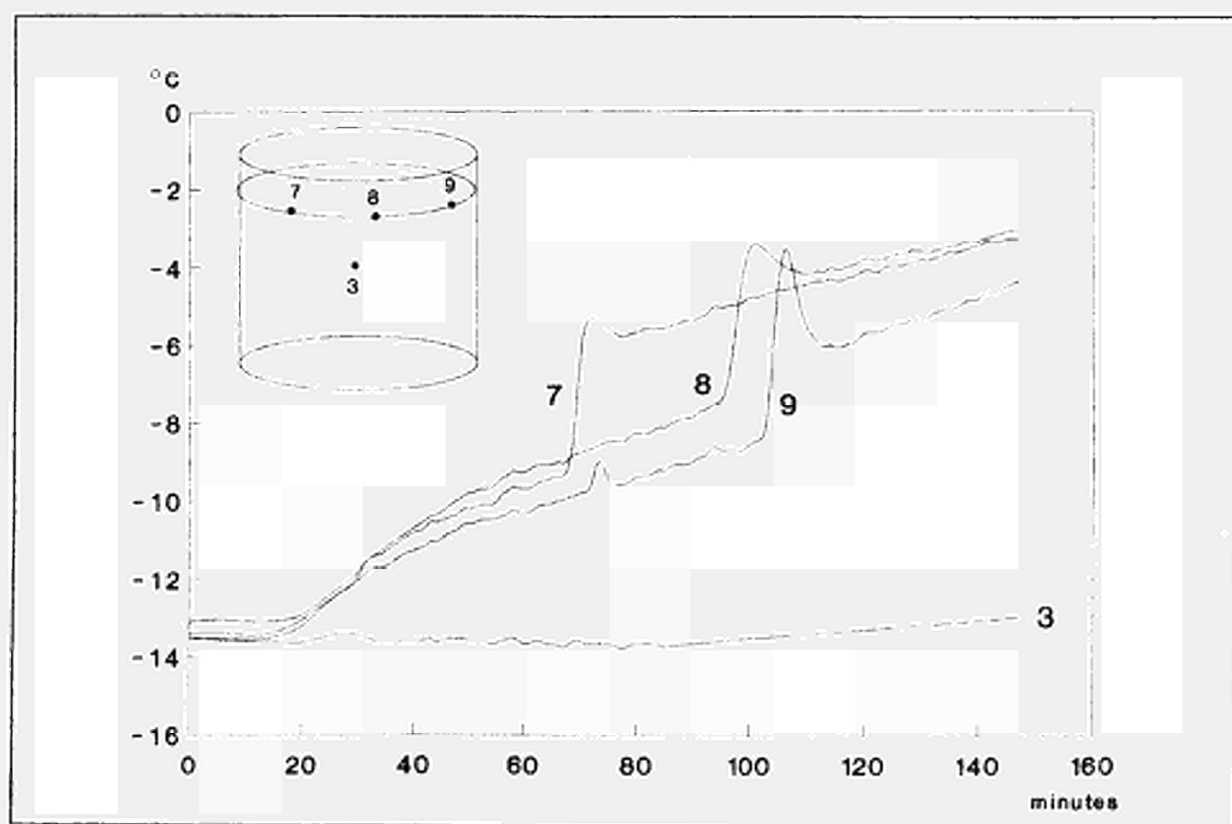

Figure 2: increase of the temperature during sawing

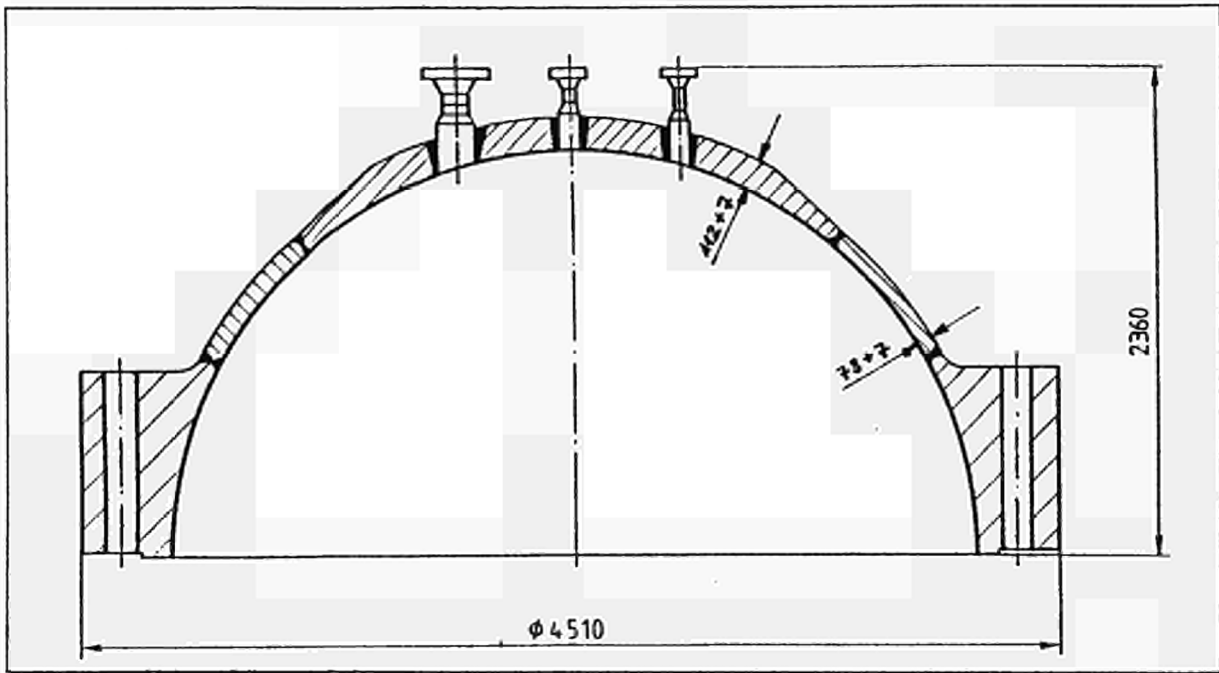

Figure 3: dimensions of the RPV-cover

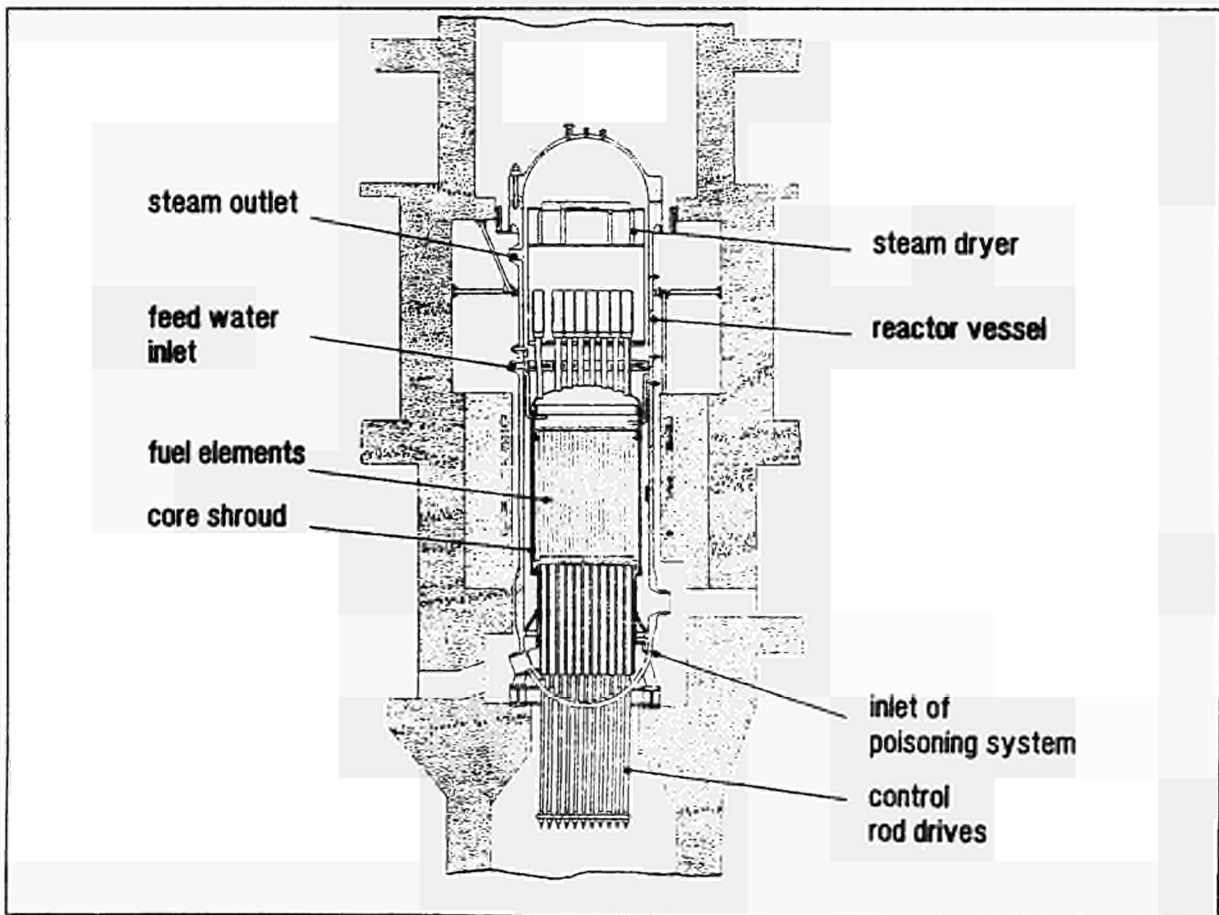

Figure 4: position of the steam dryer in the reactor pressure vessel

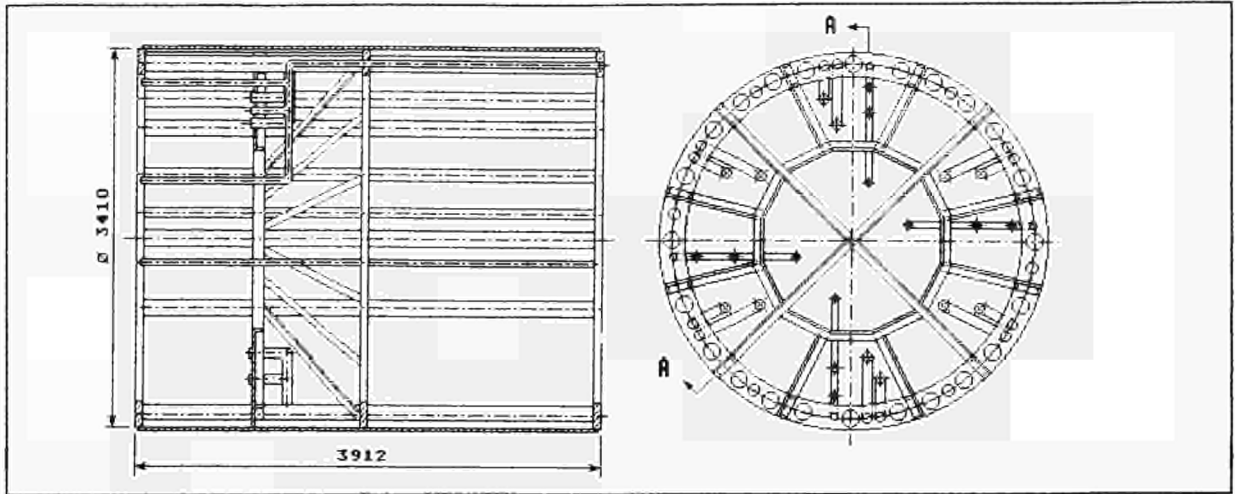

Figure 5: design of the steam dryer

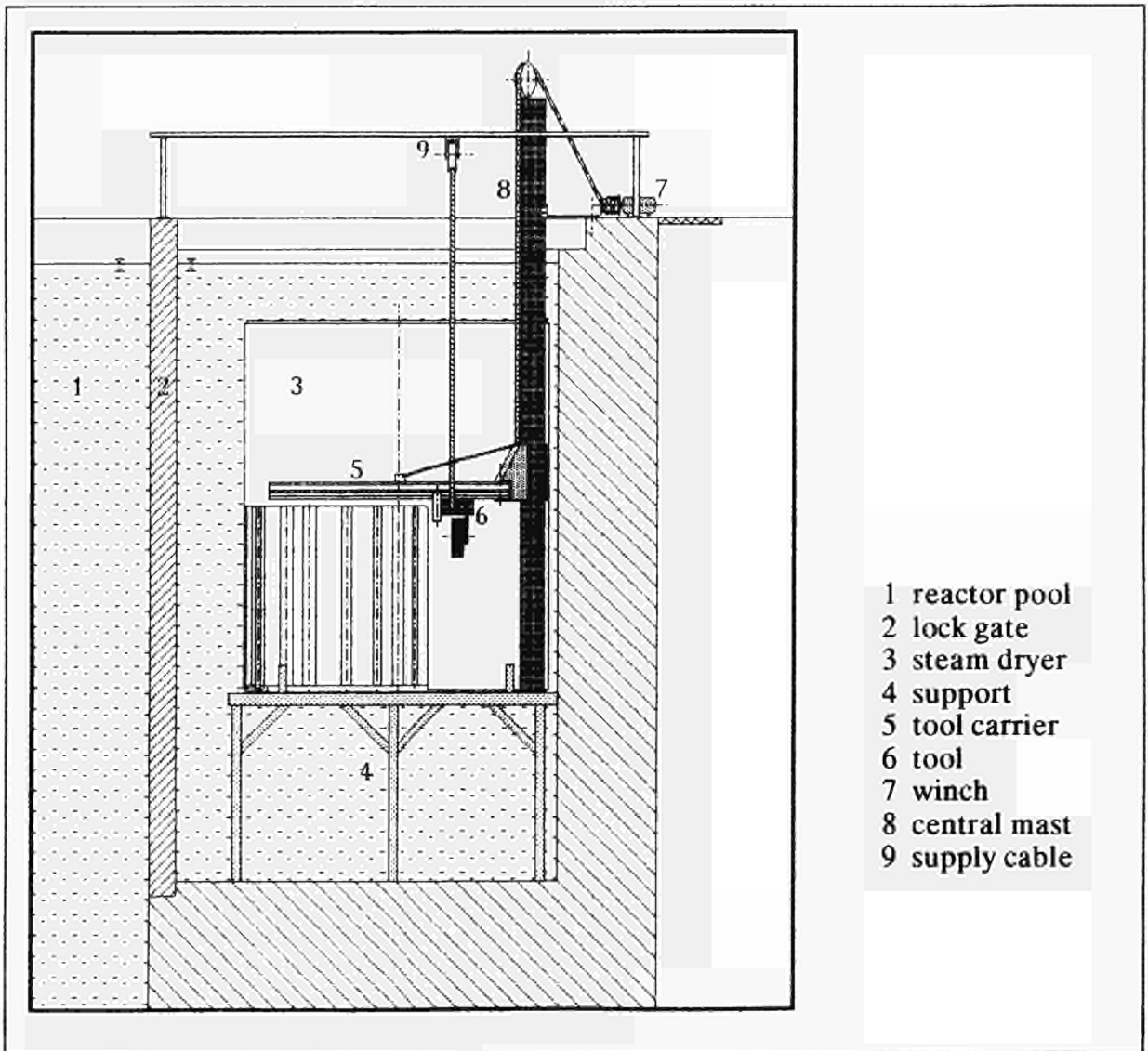

Figure 6: side view of the cutting system

7.6. DECOMMISSIONING OF THE RISØ HOT CELL FACILITY

Contractors: RNL
Contract No.: FI2D-0011
Work Period: July 1990 - December 1993
Coordinator: H CARLSEN, RNL
Phone: 45/423/712 12 Fax: 45/423/511 73

A. OBJECTIVE AND SCOPE

The Risø Hot Cell Facility, which was in operation for 26 years (1964-1990), comprises six concrete cells, lead cells, glove boxes, a shielded unit for temporary storage of waste until shipment, a frogman area, decontamination areas, workshops, various installations of importance for safe operation of the plant, offices, etc. The facility presented was used for physical and chemical post-irradiation investigations of various types of fuel pins (LWR, HTGR), including Pu-enriched pins.

The general objective of the decommissioning programme for the Hot Cell facility is to obtain a safe condition for the whole building that does not require the special safety provisions which were necessary for operation of the hot cell plant. As a result, the Hot Cell building will be usable for the other purposes.

Work includes the removal of all irradiated fuel items, of other radioactive items and of contaminated equipment, and decontamination of all cells and rooms. The project is expected to produce specific data on manpower, waste arisings and radiation exposures for the decommissioning of a total hot cell line.

The contractual work will lead to the identification of an assessed procedure appropriate for the decontamination and the dismantling of equipment of a hot cell line used for post-irradiation tests on nuclear fuel pins of different types.

The contractor will execute the work programme in co-operation with BNFL plc, Sellafield (UK), which is decommissioning the B 205 Fuel Reprocessing Pilot Plant, by using, to any suitable extent, common techniques, procedures and instrumentation.

The latest dose rate measurements determined after a former partial decontamination of a concrete cell were in the order of magnitude of 1-2 mGy/h.

B. WORK PROGRAMME

- B.1. Removal of fissile material** in the form of uranium oxides and uranium/plutonium mixed oxides
- B.2. Dismantling, transfer and decontamination of large cell internals**, including the power manipulator, the cell crane and all experimental equipment.
- B.3. Removal and decontamination of large equipment**, including all lead-shielded steel boxes and glove boxes, the shielded storage facility, the conveyer, the microscope cell.
- B.4. Decontamination of concrete cells** by various procedures, with preceding and subsequent radiation measurements
 - B.4.1. Initial mapping of radiation levels in remote operation
 - B.4.2. Coarse cleaning by vacuum cleaning, conventional washing and possibly by special techniques
 - B.4.3. Final cleaning with conventional methods
 - B.4.4. Hot spot removal by special techniques.
- B.5. Decontamination and radiological measurements of cell ventilators and ventilation ducts**
- B.6. Decontamination of room surfaces**
- B.7. Removal of active drains from various facilities**
- B.8. Generation of specific data** on costs, radioactive job doses, working time and secondary waste arisings, derived from the execution of items B.2. to B.7.

C. Progress of Work and Obtained Results

Summary of main issues

Most of the work performed has been of an initiating and conventional character, consisting mainly in removal of fissile and contaminated material.

Coarse cleaning of the lead shielded steel boxes and the glove boxes was initiated.

Some not contaminated equipment was removed from the facility, and areas not in use any more were allocated to other non-nuclear activities, where possible.

One experience has been gained. When planning to shut down on a nuclear site the only facility able to handle highly active material, it is most important to include all possible sources for such scrap material. Obviously, any voluminous scrap material must be delivered and processed in due time. We did not at the very starting point of our planning include all potential scrap material from the reactor site at Risø. An extra work effort on this task, however, resulted in acceptable remnants at the reactor site.

Progress and Results

1. Removal of fissile material (B.1.)

Packing of fissile fuel material in stainless steel containers has progressed well. Except for some acid solutions of fuel from burnup determinations, which will require chemical processing before being packed, all fuel has been packed, and most of it has been transferred to the Risø Waste Treatment facility for temporary storage.

2. Dismantling, transfer and decontamination of large cell internals (B.2.)

Packing of contaminated scrap material has progressed well. The material in the Hot Cell facility consists of various experimental and shop equipment, most of which is contaminated only at a lower level. Its form and surfaces is, however, of such a nature that decontamination is impossible. Besides the material in the Hot Cell facility we have processed large amounts of rigs etc. from the DR3 reactor at Risø, all of which was of a similar nature. Depending on size and the degree of radiation the material is packed in different types of containers; common to these containers is that they provide only little — if any — shielding; only their volume differ. Before being packed the material is cut into pieces that fit the form of the container as well as the position among other pieces in the container; further, any smaller items are put into larger, hollow items where possible. In this way an optimal degree of packing in each container is obtained, and similarly a minimum storage volume is required. The amount of material from outside the Hot Cell facility was underestimated at the very first step of the planning. All the packed material has been or will be transferred to the Risø Waste Treatment facility for temporary storage.

3. Removal and decontamination of large equipment (B.3.)

Coarse cleaning of the lead shielded steel boxes and the glove boxes was initiated. A delay in manpower employment caused limited progress on this task. Our plan is to put together heavily contaminated equipment from all of the glove boxes into one box and then consider this box as one heavily contaminated unit, which will be stored without further labour and dose commitments. The emptied boxes will be decontaminated.

4. Decontamination of concrete cells (B.4.)

Techniques for decontamination have been examined, in part by a study tour to the United Kingdom:

- High pressure water jetting equipment already purchased was tested in clean environments.

- Sand blasting techniques was purchased and tested in clean environments.
 - Foam cleaning technique was studied.
- All the above mentioned techniques were technically found suitable for the foreseen jobs. BNFL at Sellafield was visited in order to survey any possible cooperation on techniques, procedures and instrumentation as prescribed in the contract. No specific area of co-operation was identified at this occasion.

7.7. FINAL CLEAN-UP OF THE PIVER PROTOTYPE VITRIFICATION FACILITY: DECONTAMINATION OF THE HOT CELL

Contractors: CEA-Valrhô
Contract No.: FI2D-0018
Work Period: July 1990 - June 1991
Coordinator: A JOUAN, CEA-Valrhô
Phone: 33/66 79 60 00 Fax: 33/66 90 14 35

A. OBJECTIVE AND SCOPE

The PIVER pilot vitrification facility at Marcoule was operated between 1969 and 1980, first using a batch process to vitrify Gas-Cooled Reactor fuel element reprocessing waste, and then to develop a continuous process to vitrify Fast Breeder Reactor (FBR) fuel reprocessing waste. A total of 12 t of glass was treated. It was then decided to remove the equipment and clean up the cell in order to install new equipment for continuous vitrification of waste generated by reprocessing FBR fuel (PIVER II).

PIVER is the first vitrification cell for fission product solutions to be decommissioned. Under a previous contract (FI1D-0057), all process equipment items of the main cell were removed, followed by preliminary decontamination carried out in remote operation. So, the internal radiation level was reduced from several Gy/h to less than 10 mGy/h. The remaining radioactivity inventory is estimated at about $1.1 \cdot 10^{13}$ Bq (300 Ci). At this level, access to the cell is now possible for durations not exceeding about one minute; the cell remains highly contaminated and requires the use of ventilated protective clothing under severe working conditions.

The work to be carried out under this contract is aimed at continuing decontamination and dismantling work enabling further dismantling of in-cell equipment with hands-on techniques and finally to reach a radiation level allowing the installation of new equipment with standard working conditions for controlled zones. In particular, the generation of specific data on costs, working hours and job doses as well as on the amount of created secondary waste is considered as an important objective of this project.

The contractual work will result in assessed decontamination procedures for highly contaminated cells.

B. WORK PROGRAMME

- B.1. Dismantling of the telemanipulators in the PIVER cell including two MT 200 master-slave manipulators, a robot manipulator (CAROLINE) and a pantograph manipulator (ANTOINE).**
- B.2. Further decontamination of the PIVER cell with various decontamination techniques (chemicals using liquids, foams and gels, electropolishing, and cryogenics), accompanied by radiological measurements.**
 - B.2.1. First stage decontamination by short time in-cell work, aimed at strongly reducing the dose rates.**
 - B.2.2. Second stage decontamination by long time in-cell operators' work.**
 - B.2.3. Final decontamination aimed at obtaining standard working conditions for controlled areas in the cell (dose rate ≤ 0.1 mGy/h).**
- B.3. Dismantling of the remaining pipes not needed for the future use of the cells.**
- B.4. Identification of the remaining cell internals by photogrammetry for facilitating design work for the reuse of the cell.**
- B.5. Generation of specific data on costs, radioactive job doses, working time and secondary waste arisings, derived from the execution of items B.1. to B.3.**

C. PROGRESS OF WORK AND OBTAINED RESULTS

Summary of Main Issues

The irradiation level in the cell at the end of 1989 was less than 10 mGy·h⁻¹, and the cell has therefore been accessible to human operators since the beginning of 1990: first for only brief periods, then for up to one or two hours per operator beginning in May. This situation made it much easier to dismantle the remaining equipment and cut up the process lines.

Major accomplishments during 1990 included:

- dismantling of now unnecessary remote manipulators;
- installation of biological shielding on remaining irradiation sources;
- cleaning up the recovery pan, drain channel and walls;
- identification and cutting of pipes.

These operations further reduced the in-cell irradiation level to less than 0.2 mGy·h⁻¹ by the end of the year. The activity removed from the cell totaled 7.11×10^{12} Bq (192 Ci), including 3.15×10^{12} Bq (85 Ci) of solid waste and 3.96×10^{12} Bq (107 Ci) of liquid waste.

Progress and Results

1. Dismantling the telemanipulators (B.1)

Remote manipulation devices in the cell included:

- a heavy telemanipulator (*Caroline*),
- a pantograph handling device (*Antoine*),
- two *La Calhène* MT 200 master-slave manipulators.

The master-slave units were removed and the penetrations were sealed with lead plugs.

Caroline and *Antoine* were moved to utility room 712 where they were cut up and conditioned in ANDRA waste containers.

2. Decontaminating the cell (B.2.1 - B.2.2)

Several decontamination operations were completed in cell 74 using very high pressure (400 bar) and high pressure (150 bar) sprayers. At the beginning of the year, the recovery pan and drain channel were decontaminated from the cell entry door to reduce the in-cell irradiation level. Throughout the year, the cell walls were cleaned from scaffolding erected inside the cell, and the recovery pan and drain channel were cleaned at regular intervals.

3. Dismantling the pipes (B.3)

3.1 Installation of biological shielding

Despite the low irradiation level in the cell, several major irradiation sources remained: the filter casings (2 Gy·h⁻¹), the hopper connecting the cell to room 075, the drain channels, the vessel pulse chambers, etc.

In order to prevent delays in decommissioning, biological shielding was provided around the irradiation sources: barited brick walls around the filter casing, lead wool and sand on the connecting hopper, and other shielding as necessary.

3.2 Identification and cutting of pipes

Some process equipment and pipes must be retained to allow continued operation of the fission product liquid storage unit in an adjacent cell beneath the PIVER cell. The pipes were first identified in 1989 using a 3D imaging system based on photos taken through the cell viewing ports were compared with cell layout drawings for precise equipment identification. Pipes provided for cutting were selected and discriminated from those that had to remain in place.

This preliminary identification was used in 1990 to mark all the process vessels and pipes that had to be retained, in order to avoid any errors during the cutup phase, and to label all equipment items that were to remain in the cell. All cut pipes were sealed with welded end-caps; the weld seams were inspected by dye-penetrant examination.

4. Irradiation sources

The drain channel contained a major irradiation source even after several high-pressure spray cleaning operations. The source was located in the drain outlet leading to a tank in cell 075; the measured irradiation level appeared to be due to diffusion of γ radiation from inside the pipe. When the pipe was filled with water up to the shutoff valve and a lead plug was installed, the irradiation diminished, confirming this assumption.

Irradiation in the hopper appeared to be attributable to diffusion of γ radiation inside the pipes, since the level remained stable after repeated decontamination.

The shielding set up at the beginning of 1990 may therefore be considered permanent.

5. Results obtained

At the beginning of 1990, the activity in cell 74 was estimated at 1.11×10^{13} Bq (300 Ci).

5.1 Decontamination wastes

Cell cleaning operations conducted throughout the year resulted in the removal of 4×10^{12} Bq (108 Ci) and generated 22 m² of liquid waste that was transferred to the Liquid Waste Treatment Station at Marcoule.

5.2 Solid Waste Removal

Thirteen ANDRA waste packages (casings and shells) comprising 3.15×10^{12} Bq (85 Ci) were removed during 1990. They contained 27 drums of miscellaneous waste (tube scraps, vacuum cleaner wastes, cleaning swabs, etc.) and dismantled telemanipulator components.

At the end of the year, some wastes that were non irradiating and only slightly contaminated were transferred to the Radioactive Decontamination Section in double or triple vinyl wrapped packages without cement grout.

5.3 Occupational Doses

The collective doses sustained by the personnel are shown in Table I for each month of 1990.

It should be noted that the pipes were cut up during June and July: this operation required more personnel because of the difficult access and working conditions (ventilated protective clothing). Moreover, as the year went by, the work advanced farther into the cell where the strongest irradiation sources were found.

5.4 In-Cell Irradiation

A radiation sensor was installed in the cell in July 1990 to allow continuous monitoring of the in-cell irradiation level, which is displayed outside the cell. The measured irradiation diminished during the year, as indicated in Table II.

Outlook

The decontamination program will be completed in 1991. This will include accurate measurements of the effectiveness of the decontamination techniques implemented.

Table I:
Occupational dose log for 1991

Month (1990)	Collective Dose	
	mSv	mRem
January	4.25	425
February	5.07	507
March	8.69	869
April	8.21	821
May	10.07	1007
June	28.75	2875
July	40.37	4037
August	18.41	1841
September	16.27	1627
October	11.17	1117
November	10.58	1058
December	6.10	610

Table II:
Cell irradiation levels in 1991

Measurement Date	Irradiation mGy·h ⁻¹
January 1990	< 10
September 1990	< 0.6
December 1990	< 0.2

7.8. DESTRUCTION OF CONTAMINATED SODIUM OF THE PRIMARY CIRCUIT OF EXPERIMENTAL RAPSODIE REACTOR

Contractors: CEA-Cadarache
Contract No.: FI2D-0022
Work Period: July 1990 - June 1993
Coordinator: P ANTOINE, CEA-Cadarache
Phone: 33/42 25 43 95 Fax: 33/42 25 48 68

A. OBJECTIVE AND SCOPE

French regulations prohibit, for safety reasons, the disposal of sodium with other low-level radwaste in shallow land burial. The development of an industrial-scale procedure for the transformation of sodium into an acceptable product is thus a useful target generally for all LMFBRS.

The CEA has developed, at laboratory-scale, the so-called NOAH procedure transforming sodium by controlled addition of water into aqueous sodium hydroxide.

The objective of the present contract is to conceive and manufacture an industrial-scale facility (600 Kg/d), based on the NOAH process and its application to 13 t (out of a total of 37 t) of contaminated sodium (specific activity 4.1 KBq/g, mainly Cs-137) from the RAPSODIE pilot FBR. The facility will be conceived thus (mobile system, limited dimensions, easy adaptation), that it can be used on other FBR-sites.

The facility will be installed at the containment building of RAPSODIE (DESORA programme). Contractual work will be implemented in cooperation between two departments of the CEA-UDIN (Unité de Démantèlement des Installations Nucléaires) and LEPE (Laboratoire d'Etudes, de Procédés et d'Expertises).

In particular, the generation of specific data on costs, working hours and job doses as well as on the amount of created secondary waste is considered as an important objective of this project.

B. WORK PROGRAMME

B.1. Conceptional studies

- B.1.1. Studies for the industrial application of NOAH (LEPE)
- B.1.2. Studies for the installation of NOAH into the RAPSODIE containment building, including the needed auxiliary equipment (UDIN)

B.2. Manufacturing, installation and testing of equipment

- B.2.1. Manufacturing and installation of equipment (UDIN)
- B.2.2. Commissioning, testing of equipment and operator training with non-radioactive sodium (UDIN)

B.3. Main operation for the transformation of sodium (UDIN)

B.4. Conditioning and disposal of generated liquid waste

- B.4.1. Investigations into possible ways for utilisation or treatment of waste including associated costs (LEPE)
- B.4.2. Temporary storage of liquid waste (UDIN)

B.5. Technical and economical balance on the feasibility for an industrial application of NOAH (UDIN)

- B.5.1. Preliminary balance before main operation
- B.5.2. Final balance after main operation, including generation of specific data on costs, radioactive job doses, working time and secondary waste arisings, derived from the execution of items B.3. and B.4.

C - PROGRESS OF WORK AND OBTAINED RESULTS

Summary of main issues

Three studies have been started :

- for the industrialisation of the NOAH process in the nuclear field. This study takes into account the results from the testing period, the new working conditions necessity and the difficulty of NOAH's implantation in the RAPSODIE containment building. A specific study for the deshumidification of the gaseous waste was ordered.
- for the installation of the machine in Rapsodie's confinement building. Technical data-sheets for sub-contractors proposals and a draught of the safety report have been prepared.
- for treatment and removal of the liquid waste (or by-product).

Progress and results

B.1.1. Studies for the industrial application of NOAH

As the NOAH prototype was not satisfactory for the DESORA operation, so to meet the new operating requirements and for a better reliability and safety a new machine was designed - see diagram 1.

The same general operating principles were considered to gain from past experience. Technological improvements integrating information from test-periods were applied. They took into account the amount of contaminated sodium to treat new safety conditions related to the industrial application of the machine in a nuclear installation. These improvements are related to the design and the building of the machine as well as its maintenance and its functional operation.

Some of them improve the installation's safety :

- separation of sodium/sodium-hydroxide/control with a minimum of sodium neighbouring sodium-hydroxide.
- maintenance of sodium temperature to a minimal value regarding the demand of each step (transfer - storage - destruction).
- calculation and design principles for the sodium transportation equipment identical to the same equipment of a nuclear power plant.
- new deshumidification of the gaseous waste which is hydrogen resulting in a 3-step purification (figure 2) :
 - devesiculation in the internal double filter (A)
 - condensation in the frozen-water-condenser (B)
 - mist-coalescence and separation in the twin-partition filter (C).

These studies have been carried out with the Framatome/Novatome company.

B.1.2. Studies for the installation of NOAH into the RAPSODIE containment building including the needed auxiliary equipment

Novatome, in charge of the studies, wrote the technical specifications necessary for the design and development of the equipment and its installation by the contractors. A draught of the Safety Report has been issued.

The DESORA installation will be entirely set up in the Rapsodie containment building. It is mainly made of :

- the sodium destruction installation NOAH, as presented above in chapter B.1.1.
- the "upline-equipment" transporting sodium
- the "downline-equipment" receiving the liquid sodium hydroxide on one hand and transporting hydrogen from the reaction tank on the other hand.
- auxiliary fluids circuits
- an equipped programmable controller for the installation.

Figure 3 shows the installation with its existing auxiliary equipment.

B.4. Conditioning and disposal of generated liquid waste

B.4.1. Investigation into possible ways for utilisation or treatment of waste including associated costs

Refer to figure 4 for detailed presentation of investigated possibilities.

Liquid soda will be recycled instead of being treated as a waste, this because of its low level of residual contamination (figure 4). But in case of a higher contamination, this choice is reversible. Several ways were investigated.

Apart from the case where sodium could be treated in a waste treatment installation the solutions are as follows (figure 5) :

- cesium is neutralized and indissolvable with PPFNI, with double-decantation through phase separation and dehydration of the waste treated with Lea Flash.
- same as above but then with phase separation through tangential filtration.
- cesium is neutralized then fixed on bar-copper columns and waste is dehydrated with Lea Flash.

Total cost including reagents, investment and waste is of about 5000 KF. The cesium fixation solution appeared to be the most feasible one.

The study was partly conducted by the Waste Disposal Department (Département de Stockage des Déchets) of CEA (DCC - DSD - CEA).

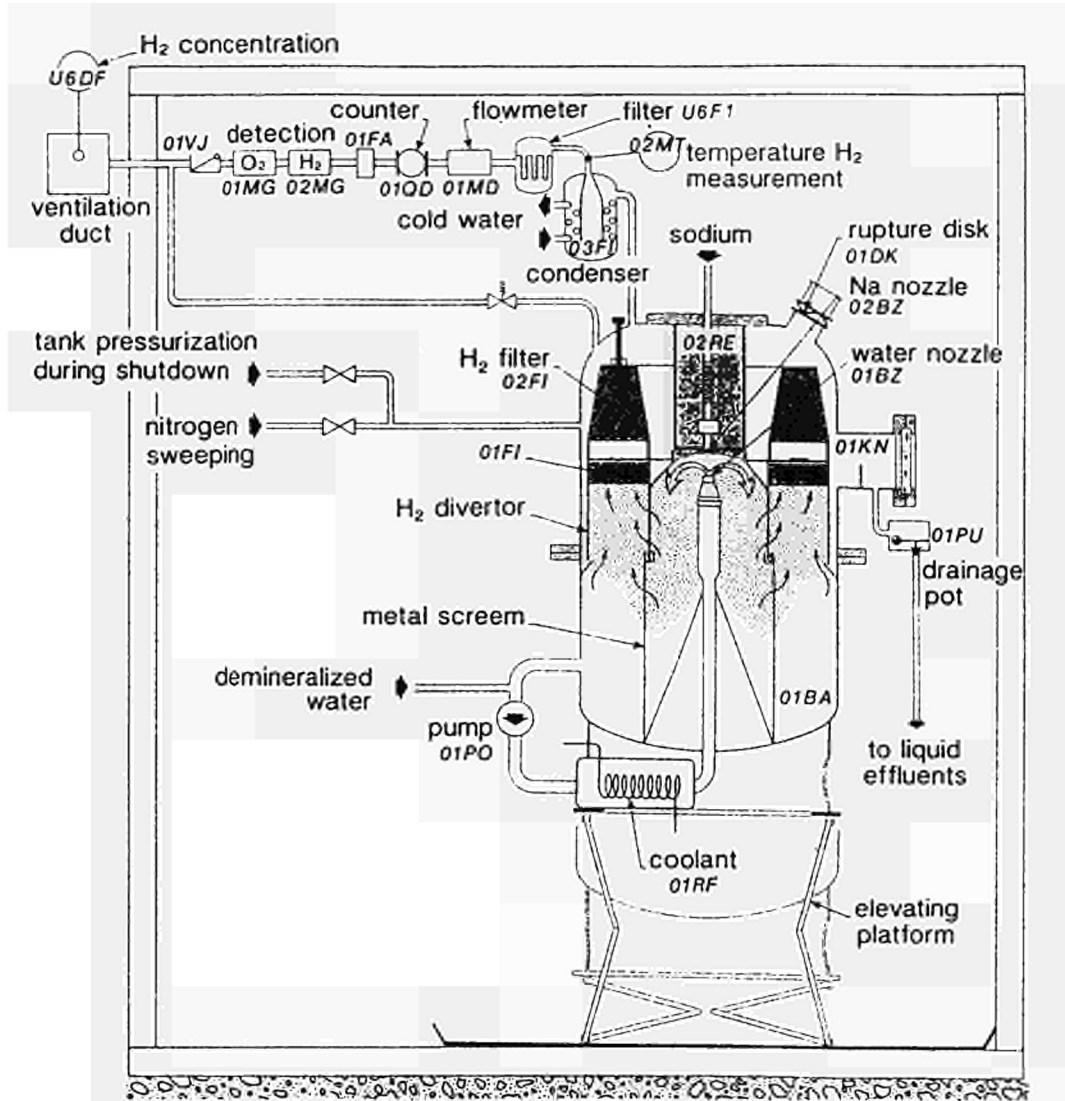

Figure 1 : NOAH sodium destruction facility
Reactor tank

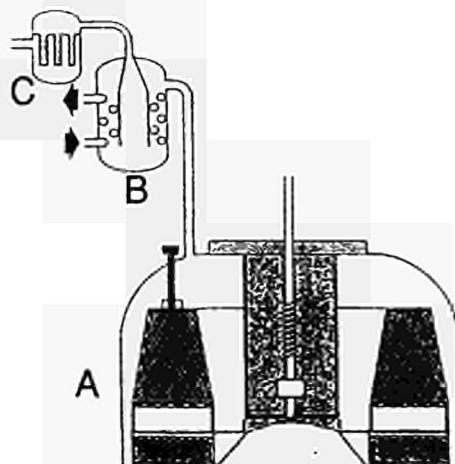

Figure 2 : Purification circuit of gaseous effluents

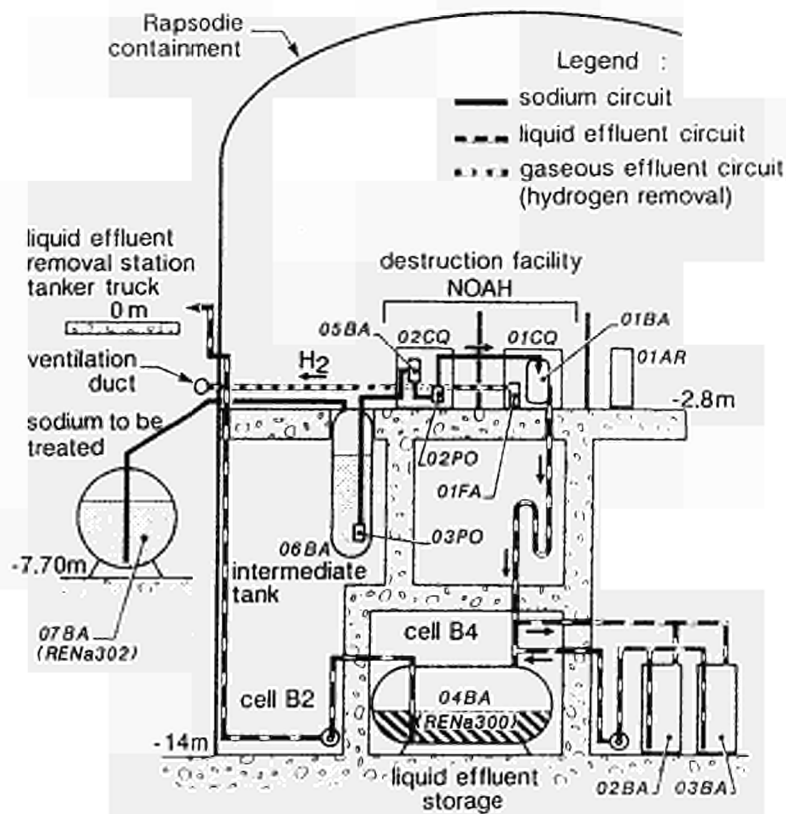

Figure 3 : Installation of DESORA in Rapsodie

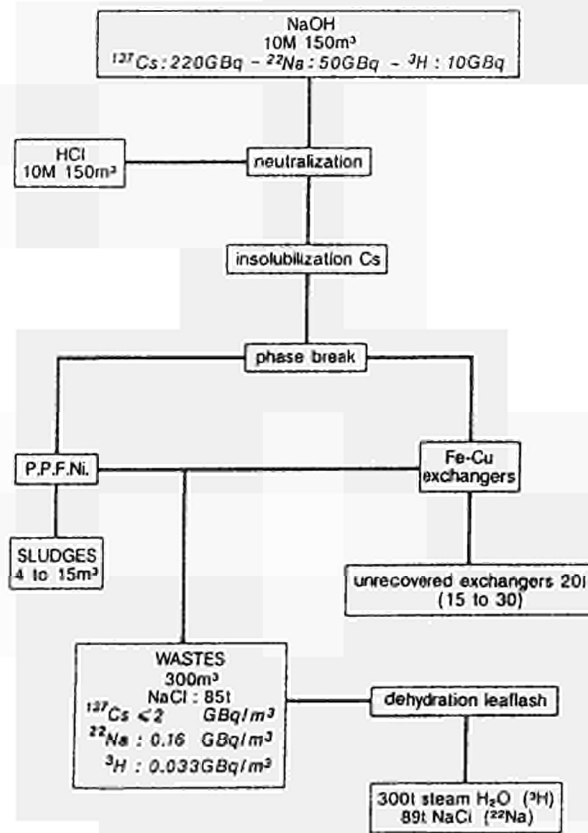

Figure 4 : Soda treatment

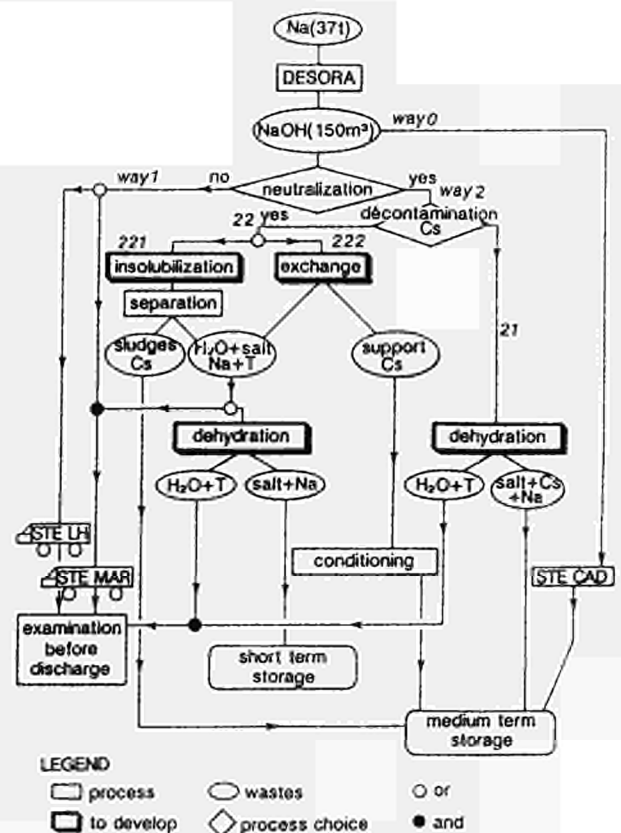

Figure 5 : Process selection

7.9. DECOMMISSIONING OF THE JEN-1 EXPERIMENTAL REACTOR

Contractors: CIEMAT, ENRESA, ENSA, LAINSA, UH-IW
Contract No.: FI2D-0023
Work Period: July 1990 - December 1993
Coordinator: L MAÑAS, CIEMAT
Phone: 34/1/346 60 00 Fax: 34/1/346 60 05

A. OBJECTIVE AND SCOPE

JEN-1 is an experimental reactor of the swimming-pool type, moderated and cooled by light water, with a power of 3 MWt. It was operated from 1958 till 1984 with a total generated energy of 2,700 MWd. The radioactive inventory is estimated in the order of 3.5.E.11 Bq (9.5 Ci), the dose rates are estimated in the range of 20 to 150 mGy/h.

The main aim of this project is the study and development of decontamination, cutting and melting techniques on contaminated or neutron-activated aluminium components of JEN-1.

Underwater segmenting of aluminium components still represents some problems to be solved, which consist especially in the limited visibility of the cutting environment, due to an important amount of very small suspended articles (10%, compared to steel 1%) and in the difficult filtration of these particles. An important aspect relevant to safety is the high H₂ generation rate due to a rather long lasting reaction of molten aluminium particles with the surrounding water.

Industrial-scale melting of aluminium components still needs development work for appropriate foundry techniques, especially concerning crucible material and slag formation.

Results obtained in this contract will be useful in the future for the dismantling of numerous research reactors with aluminium components.

The project is expected to produce specific data on costs, working time, waste arisings and radiation exposures to operators for the dismantling of the JEN-1 reactor.

The work programme will be implemented in co-operation between following Spanish organisations: CIEMAT, ENRESA, ENSA and LAINSA, and with Institut für Werkstoffkunde of Universität Hannover (UH/IW), CIEMAT being the coordinator. A close co-operation on aluminium melting will be installed with Siemens AG KWU Group and Siempelkamp Giesserei Krefeld (SG).

B. WORK PROGRAMME

B.1. Radiological characterisation of components to be dismantled, and of melting products (CIEMAT)

- B.1.1. Radiological characterisation of the grid and support grid.
- B.1.2. Radiological characterisation of the control blade housings.
- B.1.3. Radiological characterisation of the melting products.

B.2. Development, manufacturing, testing and subsequent installation in the JEN-1 reactor of an underwater cutting facility by plasma arc and by consumable electrode techniques (UH-IW, CIEMAT).

- B.2.1. Development and manufacturing of prototypes of plasma arc torch and consumable electrode torch (UH-IW)
- B.2.2. Cutting tests with both tools on representative aluminium sheets, aiming at defining optimal working parameters, cutting effluents and appropriate air and water filters (UH-IW, CIEMAT)
- B.2.3. Comparison of both tests with respect to cutting performance, generation and type of cutting effluents and tool handling abilities with subsequent selection of the most appropriate tool (CIEMAT + UH-IW)
- B.2.4. Design and manufacturing of a cutting facility, including the selected cutting tool, handling and sensor systems and the cutting cell (UH-IW)

- B.2.5. Testing at UH-IW and optimisation of the whole system in water depths of 5 m (UH-IW, CIEMAT)
- B.2.6. Training of the CIEMAT staff at UH-IW (UH-IW + CIEMAT)
- B.2.7. Transport and assistance for the installation of the cutting facility in the JEN-1 reactor (UH-IW)
- B.3. Underwater dismantling of reactor internals after preceding dismounting work (CIEMAT + UH-IW)**
 - B.3.1. Dismantling of the grid and grid support
 - B.3.2. Dismantling of the control blade housings
- B.4. Decontamination of reactor internals (ENSA, LAINSA).**
 - B.4.1. Selection of suitable procedures with respect to decontamination efficiency, amount and type of arising secondary wastes, reprocessing abilities and radiological impact
 - B.4.2. Decontamination of the grid and grid support
 - B.4.3. Decontamination of the control blade housings.
- B.5. Melting of aluminium waste (CIEMAT, ENRESA)**
 - B.5.1. Selection, manufacturing and adaptation of a melting furnace and implementation of cold melting tests.
 - B.5.2. Main melting programme, including generation of data on volume reduction and decontamination effects.
- B.6. Assessment of radiation protection including both the personal and the ambient radiological impact (CIEMAT, UH-IW)**
 - B.6.1. Assessment of radiological impact during dismantling operations (CIEMAT, UH-IW)
 - B.6.2. Assessment of radiological impact during decontamination operations (CIEMAT)
 - B.6.3. Assessment of radiological impact during melting operations (CIEMAT)
- B.7. Generation of specific data on costs, radioactive job doses, working time and secondary waste arisings, derived from the execution of items B.3., B.4., B.5. and B.6.**

C. Progress of Work and Obtained Results

The dismantling activities of the reactor core have not been started, due to the delay in the transfer of fuel elements out of the swimming pool of JEN-1.

For cutting operations, CIEMAT has received a plasma arc cutting facility, PAK45, 80 KVA of power and a maximum of 400A. Cutting operations with this unit have been started, mainly as training for the operators.

Design and development cutting activities are being performed by IW (Hannover University) about handling control of cutting operations, basin cutting and exhaust air system for aerosols control.

Concerning melting, as a recycling material method, design of melting installation and building, where the furnace is to be placed, has been achieved.

Progress and results

1. Characterization of components (B.1.)

Several analyses have been done on the same materials from which the reactor core was made up, in order to know the different impurities of these aluminium alloys. On Table I are given the results of these analyses.

2. Development and manufacturing of prototypes of plasma arc torch and consumable electrode torch (B.2.1.)

In order to protect personal against dose exposure, IW has designed a torch with a plug-in consumable part (nozzle and electrode mounted together) which can be exchanged all in one by a manipulator under water. A prototype of this torch has been already tested successfully at IW.

A sketch of the consumable electrode tool is shown in Fig. 1, which is composed of the torch body with a connection for the water hose, the motor and winding gear and wire straightening device.

3. Cutting tests (B.2.2.)

Cutting tests have been undertaken by IW on aluminium materials with the goal to obtain the optimal working parameters (speed and power cutting) using a mixture of argon and nitrogen as plasma gas and compressed air as secondary gas. In the same way cutting effluents and appropriate air and water filters are being studied. On the other hand, CIEMAT has started plasma arc cutting tests in a pool 1 m³ volume with a maximum water cutting depth of 1 m, as a training of people involved with plasma arc cutting operations.

4. Design and manufacturing of a cutting facility (B.2.4.)

IW is designing a handling control device for three axis to adapt body torches, which will be manufactured by CIEMAT, and a basin cutting where the above device will be placed. Concerning control of cutting, IW is investigating into ultrasonic sensors for the determination of the distance between tool and workpiece as well as the material thickness.

5. Melting of aluminium waste (B.5.1.)

Design is being carried out about the settlement of the building where the melting furnace will be placed.

An induction melting furnace has been acquired which main characteristics are the following: Type: induction heating; Nominal capacity: 50 Kg; Power: 65 KVA; Frequency: 3000 Hz.

The aim of this activity is the melting of aluminium scrap coming from cutting operations in order to study distribution of activity among ingots and slag, as a recycling material method.

6. Assessment of radiation protection (B.6.)

Radiological measurements have been made on different components of the reactor core, in order to get the first dose rate estimations. These measurements have been carried out at different levels of the JEN-1 reactor core, and the results are given on Table II.

Table I: Impurities Content of Aluminium (JEN-1 Reactor)

Elements (%)	Blade Control Housings (Al-99,5)	Grid and Support (Al-Mg)
Bi	0,003	0,002
Cr	0,0024	0,20
Cu	0,0085	0,024
Fe	0,38	0,34
Mn	0,043	0,09
Ni	< 0,002	< 0,003
Pb	0,0051	0,005
Si	0,12	0,36
Sn	< 0,003	< 0,03
Ti	0,0077	0,012
V	< 0,002	0,003
Zn	0,028	0,030
Mg	--	2,5

Table II: Dose Rates at Reactor Core JEN-1

Level	Dose Rate mSv/h
1.- Core grid	150
2.- Middle plane of the core	20
3.- Top of the blade housings	20
4.- Top of the thermal column	6
5.- Diffuser of coolant system	5

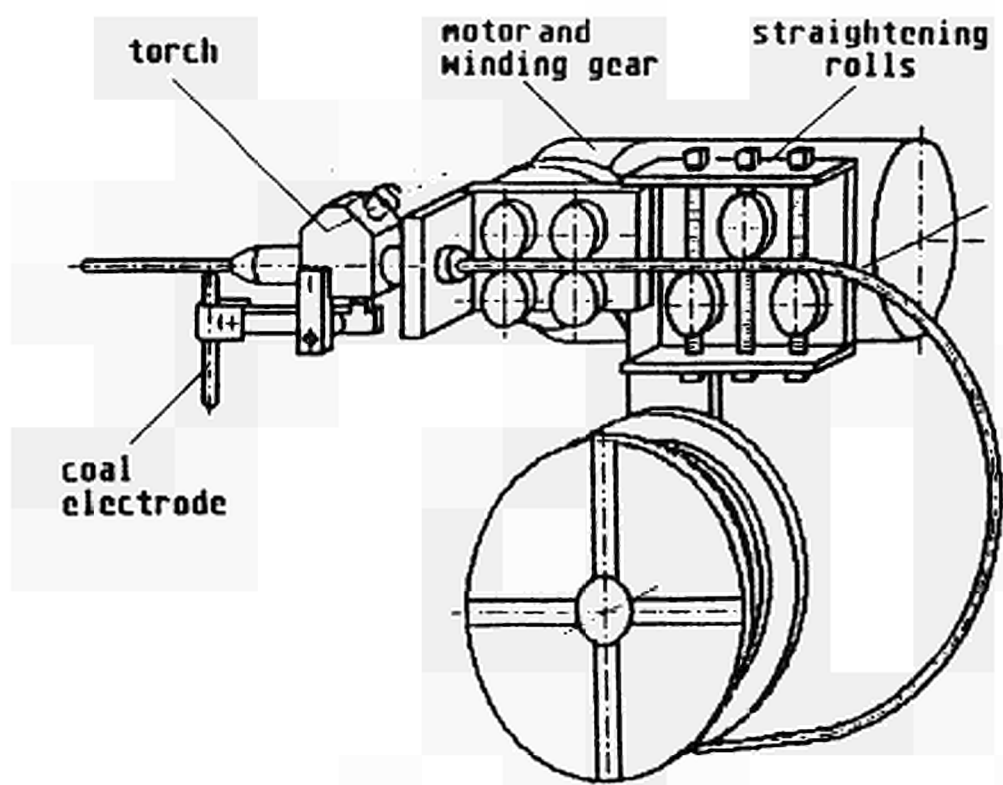

Fig. 1- Sketch of the consumable electrode tool

7.10. DEVELOPMENT OF SEGMENTING TOOLS AND REMOTE HANDLING SYSTEMS AND APPLICATION TO THE DISMANTLING OF VAK BWR REACTOR PRESSURE VESSEL INTERNALS

Contractors: VAK GmbH
Contract No.: FI2D-0029
Work Period: July 1990 - December 1993
Coordinator: L PACHL, VAK
Phone: 49/61/882 081 Fax: 49/61/883 861

A. OBJECTIVE AND SCOPE

The experimental Boiling Water Reactor Kahl (VAK-BWR) of 16 MWe has been shut down after 25 years of operation. Dismantling has been started for some time. The present estimation of the radioactive inventory of the reactor is in the order of $1.35 \cdot 10^5$ Ci.

The aim of the present contract is the development, qualification and practical application of different underwater (UW) segmenting and remote handling techniques on a series of internal components out of the reactor pressure vessel (RPV). Important targets are: minimisation of operators' dose uptake and of primary and secondary waste generation and economics of the procedure. Specific radioactivity of such components is in the order of magnitude of $10^5 - 10^8$ Bq/g (activation) and of $10^4 - 10^5$ Bq/g (contamination). Due to its long-term operation, VAK dismantling can be considered to a large extent (dose rates, activation, contamination, material ageing) as representative for the future decommissioning of LWRs. In particular, the generation of specific data on costs, working hours and job doses as well as on the amount of created secondary waste is considered as an important objective of this project.

Work will be implemented in close co-operation with the pilot dismantling projects BR-3/Mol (§ 7.3.) and KRB-A (§ 7.5.). The results of the comparative assessment study made by KRB (§ 7.2.) will be considered in the implementation of the contract.

B. WORK PROGRAMME

- B.1. Conceptional studies and construction of a 1:1 scale facility for UW testing of cutting tool and devices for remote operation**
- B.2. Preliminary tests on non-radioactive components, including devices for segmentation, remote operation techniques, definition of generated secondary waste and studies of dismantling scenarios**
- B.3. Qualification of dismantling procedures for an application to radioactive components**
- B.4. Dismantling of a series of RPV internals (upper grid plate, chimney above the core, control systems)**
- B.5. Generation of specific data on costs, radioactive job doses, working time and secondary waste arisings, derived from the execution of items B.2., B.3. and B.4.**

C. PROGRESS OF WORK AND OBTAINED RESULTS

Summary of main issues

An additional evaluation of 7 firm offers for the decommissioning of VAK and KRB-A, performed by NIS and NUKEM, resulted in a modified dismantling concept. Contrarily to the hardware configuration followed since, main attention is given now to such technologies, producing a minimum of aerosols. Reasons therefore are the matching of secondary waste and the consequent costs.

Thus plasma melt cutting for core internals was replaced by mechanical cutting techniques.

Though the means of a double arm EMSM (Electric Master Slave Manipulator) in the dismantling concept is still taken into consideration, it will no longer serve for handling of cutting tools. The new tasks for it are: handing of the video system, place sucking nozzles, change tools etc.

RPV wall and rotation symmetric components shall be cut with a circumferential support for mechanical tools.

For dismantling of core internals with complex geometries, special tools shall be used which allow their handling inside fuel elements and absorber shafts.

RPV as well as internals shall be cut to package size on site, the EMSM shall support this undertaking.

Progress and results

1. Conceptual studies and construction of a 1:1 scale facility for UW testing of cutting tool and devices for remote operation (B.1.)

For planning the test installation it is necessary to examine, which cutting technology (mechanical or thermal) in close connection with the cutting support technology (for instance electrical master-salve-manipulator, telescope mast, circumferential tool support etc.) and which handling technology for cut pieces, tools, containers etc. will probably be used.

The choice of the cutting- and handling technology was performed in two steps:

1.1. Performance of proposed concepts for decommissioning of VAK and KRB-A

The evaluation of 7 firm offers (2 for VAK and 5 for KRB-A) was performed without consideration of the specific differences between VAK and KRB-A, such as plant dimensions, fuel pool availability for additional dismantling, and was performed without consideration of different specific features like level of automatization, use of an outer "sleeve" for underwater dismantling of the RPV-wall, use of simple, well-known tools etc.

An independent evaluation team analysed all received offers for completeness by means of an assessment matrix.

Following criteria are considered as principal: technology, safety and costs. In Table I, the considered subcriteria for each main criterium are presented. The evaluation of considered subcriteria was made with a rating scale of 1 = worst mark and 6 = best mark, and with a weighing scale for their relative importance going from 1 = low to 3 = high. In figure 1, the mean results of the numerical evaluation are presented for the 7 proposed dismantling concepts; proposals A and B are concerned with the VAK-BWR dismantling proposals C to G with the KRB-A dismantling. As can be stated, the evaluation did not result in an outstanding or peak rating. Among the various proposed concepts, common approaches could be found or agreement on significant features. Common features for an optimized approach are summarized in Table II.

1.2. Evaluation of supplementary criteria

In a second approach, we have evaluated supplementary criteria which were insufficiently or not at all considered in the received offers, like local dose up-take during handling, secondary waste volume production, use of mechanical or thermal cutting tools, spreading of dust and aerosols into the containment, components of decommissioning equipment, especially air and water cleaning, crane communication, measurement of mass- and activity inventory, needed manpower and personal dose up-take, waste container logistics and detailed costs.

Based on the results of the additional evaluation performed by NIS and NUKEM we got a new optimized dismantling equipment (Table III), which is characterized mainly by a predominance of mechanic segmenting tools.

The test installation to be installed shall demonstrate the appropriateness of this equipment, consisting of a circumferential tool support for various but mainly mechanical tools and including an EMSM dedicated to specific tasks including the handling technology for the cut internals and RPV wall pieces, filter technique, TV-technique, container logistics, tool exchange, radiation protection etc.

This test installation shall be used for the assessment of the appropriate interaction between circumferential tool support or special tools and EMSM and will also be applied for training of the decommissioning team under cold conditions.

Tab. I: Considered main and sub-criteria for the evaluation

Main criteria	Sub-criteria
Technology	Completeness Reliability Maintainance and repair friendliness Universality Project relevance of preliminary tests Minimization of primary waste Minimization of secondary waste
Safety	Minimization of man dose (mSv) Design basis accident control Accident prevention
Costs	Hardware R&D and Personnel Dismantling time

Tab. II: Optimized dismantling equipment and tasks (1st step)

Equipment	Tasks
Circumferential tool support	<ul style="list-style-type: none"> - mechanical segmenting of rotation-symmetric <ul style="list-style-type: none"> - internals (thermal shield, core casing) - RPV-wall
EMSM	<ul style="list-style-type: none"> - support for the underwater plasma arc cutting of internals (core grids, chimney, rods and pipes), - positioning of TV-cameras, - construction of crane communication - exchange of tools

Tab. III:

Optimized dismantling equipment and tasks (2nd step)

Equipment	Tasks
Circumferential tool support	<ul style="list-style-type: none"> - mechanical segmenting of <ul style="list-style-type: none"> - rotation-symmetric internals (thermal shield, core casing) - RPV-wall
Special tool	<ul style="list-style-type: none"> - mechanical segmenting of <ul style="list-style-type: none"> - internals (core plates, chimney, rods, pipes)
EMSM	<ul style="list-style-type: none"> - positioning of <ul style="list-style-type: none"> - special tools, - TV-cameras, - aerosol captation devices - construction of crane communication, - exchange of tools, - support container handling

Evaluation mark

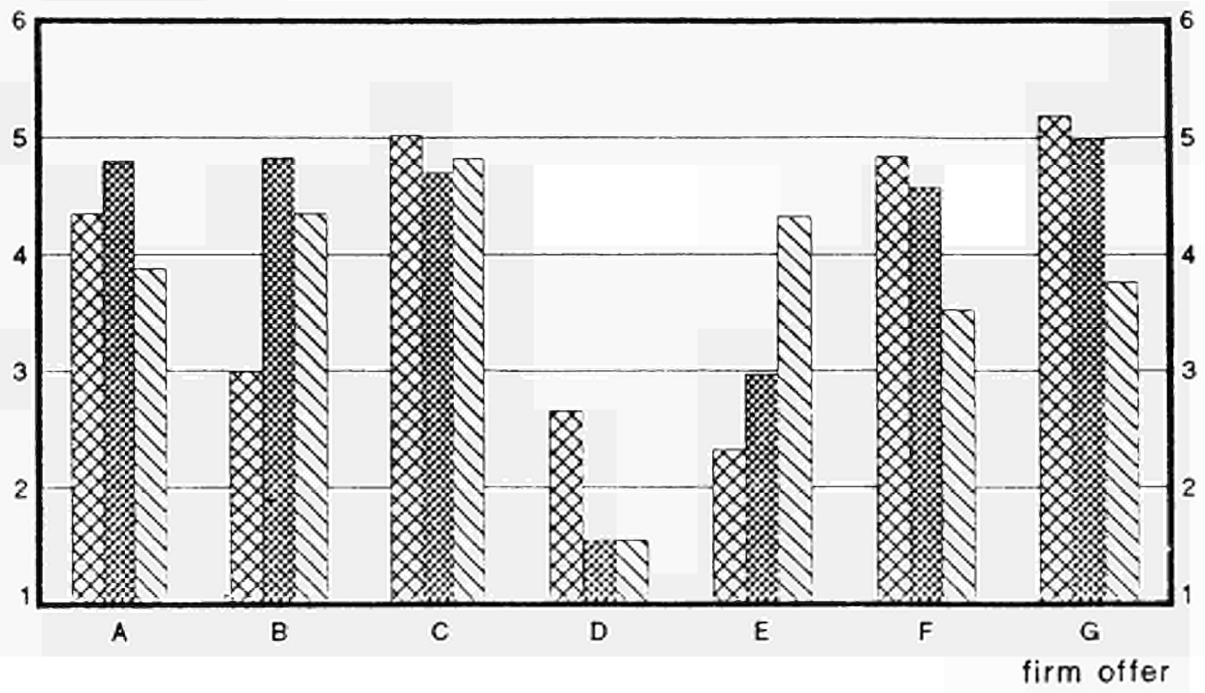

V1 (technology aspect)



V2 (safety aspect)



V3 (cost aspect)



Fig. 1: Mean results of evaluation

7.11. MELTING OF FERRITIC STEEL ARISING FROM THE DISMANTLING OF THE G2/G3 REACTORS AT MARCOULE IN A FURNACE INSTALLED AT THE DISMANTLING SITE

Contractors: CEA-Valrhô
Contract No.: FI2D-0034
Work Period: September 1990 - December 1991
Coordinator: J L DECITRE, CEA-Valrhô
Phone: 33/66 79 63 03 Fax: 33/66 79 64 32

A. OBJECTIVE AND SCOPE

In two foregoing EC R&D decommissioning programmes, a series of research contracts had been devoted to melting of metallic radwaste, mainly steel, going from laboratory scale to applications in adapted foundries, treating waste transported from the dismantling site to the melting facility.

The objective of the present contract is to conceive, manufacture and install a 15 t electric arc heated melting furnace on the dismantling site of the G2/G3 graphite/gas reactors at Marcoule, and to condition by melting 700 t (out of a total of 4,000 t) of ferritic steel having a specific contamination in the order of 20 - 40 Bq/cm².

The innovation lies mainly in the on-site installation of the furnace, avoiding packaging and transportation on public roads and in the large dimensions of the furnace (2 m), enabling feeding of pieces up to 1.7 m and reducing segmenting work. This should lead to economics by reducing the number of operations and by an optimised management of waste streams, enabling to a large extent unlimited recycling of steel.

In particular, the generation of specific data on costs, working hours and job doses as well as on the amount of created secondary waste is considered as an important objective of this project.

B. WORK PROGRAMME

B.1. Conceptual studies and categorisation of waste

- B.1.1. Studies for the installation of the melting furnace in the reactor building.
- B.1.2. Investigation into the management of waste streams before and after melting.

B.2. Manufacturing, installation and testing of equipment

- B.2.1. Manufacturing and installation of equipment including auxiliary and control systems.
- B.2.2. Commissioning testing of the melting facility.

B.3. Main operation for the melting of 700 t of dismantled steel

- B.4. **Generation of specific data** on costs, radioactive job doses, working time and secondary waste arisings, derived from the execution of items B.1., B.2. and B.3.

C. PROGRESS OF WORK AND OBTAINED RESULTS

Process and installation studies for the melting facility have been completed (B.1.1.).

Studies related to the definition and management of waste, before and after melting are nearly completed (up to 80 %). Studies of steel quantification methods before and after melting are almost totally done (up to 70 %). Preparatory works for the auxiliary equipment are finished. Civil works have been started (external buildings and structure strengthening for the melting facility).

Large equipment (furnace, power transformer, ingot-maker and travelling crane) is being developed with the manufacturers. It is expected that the furnace will be delivered to the site on May 1st, 1991. Apart from a slight delay at the start-up of the manufacturing and procurement of equipment, work is now on schedule.

Dismantling work of the pipes is completed, followed by the construction supplies for the melting facility representing several weeks of operation.

Fine quantification measurements of waste are satisfactory and show that 90 % of the steel to be melted has an activity of less than 1 Bq/g.

7.12 MELTING OF ALPHA-CONTAMINATED STEEL SCRAP AT INDUSTRIAL SCALE

Contractors: Siemens-KWU, SG
Contract No.: FI2D-0038
Work Period: October 1990 - December 1993
Coordinator: K H GRÄBENER, Siemens-KWU
Phone: 49/69/807 36 45 Fax: 49/69/807 20 66

A. OBJECTIVE AND SCOPE

The underlying large-scale investigation into melting of alpha-contaminated steel from nuclear facilities aims at demonstrating the feasibility of the unrestricted reuse of such radwaste within legal limits.

The work programme will be based on the results and experience obtained on melting of radwaste in former research contracts within the second EC programme on Decommissioning (1984-88), especially contract FI1D-0044 with Siemens AG and contract FI1D-0016 with Siempelkamp Giesserei GmbH.

Starting with laboratory-scale melts aimed at identifying the most suitable crucible material and slag former will be followed by large-scale melts with subsequent detailed analysis of the prevailing alpha-distribution in and between steel, slag and filter dust.

Based on the foregoing results, large-scale melts with about 100 t of uranium and Pu-contaminated material from Siemens fuel fabrication will be carried out and finally, by two large-scale melts of Pu- and Th-contaminated steel waste (5 t), will be assessed how these alpha-emitters will behave.

It is anticipated that extensive testing and radiological measurements will enable the assessment that alpha-contaminated steel can be conditioned by melting for safe unrestricted reuse and that the melting plant can be operated safely also with respect to radiation protection of workers and the environment of the foundry, with special consideration of the arising slag and filter dust. In particular, the generation of specific data on costs, working hours and job doses as well as on the amount of created secondary waste is considered as an important objective of this project.

The specific contamination of the treated radwaste is estimated to be in the range of ≤ 200 Bq/g (alpha/beta) and the anticipated fission product inventory for large-scale melting is estimated at about 200 g of U-235 and 1 g of Pu. Expected dose rates in the controlled melting area are in the order of magnitude of < 0.1 mGy/h.

Work will be executed in close co-operation between Siemens AG, KWU Erlangen (Siemens) acting as coordinator and Siempelkamp Giesserei (SG).

B. WORK PROGRAMME

- B.1. Identification of appropriate materials for crucible and slag formers and procurement of U, Th and Pu containing radwaste samples (SG)
- B.2. Installation of an induction-heated laboratory furnace and execution of reference tests with non-radioactive materials (Siemens)
- B.3. Laboratory-scale melting tests with U, Th and Pu-contaminated steel (selection of materials for crucible lining and slag formers) (Siemens)
- B.4. Procurement of U and Pu-contaminated material (Siemens) and Th-contaminated material (KEMA)
- B.5. Pilot melting tests aimed at determining the U (alpha)-content in ingot, slag and filter system (SG, Siemens)
- B.6. Main melting programme of about 100 t of U and Pu-contaminated radwaste with subsequent alpha-content determination in each ingot, slag and filter dust (SG)
- B.7. Execution of two large-scale melts with Pu and Th-contaminated steel (SG)
- B.8. Determination of the alpha-distribution in the crucible material (Siemens)
- B.9. Generation of specific data on costs, radioactive job doses, working time and secondary waste arisings, derived from the execution of items B.2. and B.6.

C. PROGRESS OF WORK AND OBTAINED RESULTS

No significant work was completed in this just starting contract.

7.13. DEMONSTRATION OF EXPLOSIVE DISMANTLING TECHNIQUES OF THE BIOLOGICAL SHIELD OF THE NIEDERAICHBACH NUCLEAR POWER PLANT (KKN)

Contractors: BE, Noell, Siemens-KWU
Contract No.: FI2D-0046
Work Period: November 1990 - October 1993
Coordinator: U FREUND, BE
Phone: 49/69/79 08 23 46 Fax: 49/69/790 880

A. OBJECTIVE AND SCOPE

This project aims at demonstrating explosive dismantling techniques on the biological shield of the nuclear power plant Niederaichbach (KKN), which was operated from 1972 to 1974 and is foreseen to be completely removed. The radioactive inventory of the shield is estimated in the order of $3.7 \cdot 10^9$ Bq (0.1 Ci). The level of activation is estimated to be in the order of 10 Bq/g, and the associated dose rates in the order of $10 \mu\text{Sv/h}$. Within this contract, blast peeling of the activated concrete from a 30° sector of the biological shield will be performed.

This technique will be applied as one of two main techniques (hydraulic hammer besides blast peeling) for the dismantling of the whole biological shield of KKN; for this, the licensing authorities have already given their agreement. This demonstration project will be conducted according to the guidelines of the ongoing total dismantling of KKN.

In particular, the generation of specific data on costs, working hours and job doses as well as on the amount of created secondary waste is considered as an important objective of this project. This will facilitate the application of this technology and acceptance from the safety point of view in future large-scale decommissioning operations.

The project is a follow-up of small-scale work on inactive samples performed jointly under contracts FI1D-0011 and FI1D-0012.

The work programme will be implemented jointly by three main contractors: Battelle Europe e.V./Frankfurt (BE), acting as coordinator, Noell/Würzburg (Noell) and Siemens/KWU (Siemens), as well as Stangenberg, Schnellenbach & Partner (SSP) as sub-contractor.

Further cooperation is foreseen with TÜV Bayern for the assessment of air filter systems.

B. WORK PROGRAMME

B.1. Preparatory planning and design work for on-site equipment and regulatory requirements (BE, Noell)

B.1.1. Layout of blasting patterns and of bore holes charging, according to the area of application (BE)

B.1.2. Design of blasting schemes according to the area of application (BE)

B.1.3. Definition of blasting area subcontainments for the retention of dust, including associated filter systems (Noell, BE)

B.2. Demonstration blasting on the KKN shield by manual handling (BE, Noell)

B.2.1. Site preparation for the installation of tools and measuring devices (BE, Noell)

B.2.2. Assessment and implementation of auxiliary techniques such as bore hole drilling, cutting of the reinforcement by hydraulic shears, use of a hydraulic ram (Noell)

B.2.3. Main operation and concrete removal, consisting of a sequence of about 10 individual blasts, including pre- and post-blast working (BE, Noell)

B.2.4. Assessment of blasting performance, with respect to predetermined criteria such as concrete removal rate, safety aspects, integrated doses and generation of secondary waste (BE, Noell)

B.3. Assessment of dust retention by industrial filter systems with respect to efficiency and safety of handling (Noell, BE)

B.4. Assessment of structural safety (BE, Noell)

- B.4.1. Modelling of shield response to the blast transient loading (BE)
- B.4.2. Modelling of building response by simple models and comparison to pre-evaluations at selected safety-relevant locations (BE)
- B.4.3. Safety control for compliance with limiting values by test accompanying measurements (BE, Noell)
- B.5. Final assessment of the blasting procedure (BE, Noell)**
 - B.5.1. Technical feasibility and reliability (BE, Noell)
 - B.5.2. Compliance with safety regulations concerning radiation protection, radioactivity release, contamination/decontamination and structural safety (BE, Noell)
 - B.5.3. Comparison with other concrete dismantling techniques, such as sawing by diamond or wire saw, core drilling, possibly combined with sawing, high pressure water jet with abrasives (Noell, BE)
 - B.5.4. Setting up of guidelines and rules for general application of the bore hole blasting technique to other shield structure, and of cost estimates (BE, Noell)
- B.6. Related investigations of general applicability to various types of nuclear power plants (BE, Siemens-KWU, SSP).**
 - B.6.1. Building response by advanced modelling for the reactor building (BE, SSP)
 - B.6.2. Local damage, prediction of cracks and material failure (BE, Siemens)
 - B.6.3. Blast loading limits with regard to the integrity of light structures in close vicinity to the charge location (BE)
- B.7. Generation of specific data on costs, radioactive job doses, working time and secondary waste arisings, derived from the execution of items B.2. and B.6.**

C. PROGRESS OF WORK AND OBTAINED RESULTS

No significant work was completed in this just starting contract.

ANNEX I

LIST OF PUBLICATIONS RELATING TO THE RESULTS OF THE 1979-83 PROGRAMME ON THE DECOMMISSIONING OF NUCLEAR INSTALLATIONS

A. Annual Progress Reports

"The Community's Research and Development Programme on Decommissioning of Nuclear Power Plants - First Annual Progress Report (year 1980)", **EUR 7440**, 1981.

"The Community's Research and Development Programme on Decommissioning of Nuclear Power Plants - Second Annual Progress Report (year 1981)", **EUR 8343**, 1983.

"The Community's Research and Development Programme on Decommissioning of Nuclear Power Plants - Third Annual Progress Report (year 1982)", **EUR 8963**, 1984.

"The Community's Research and Development Programme on Decommissioning of Nuclear Power Plants - Fourth Annual Progress Report (year 1983)", **EUR 9677**, 1985.

B. 1989 European Conference

Schaller, K.H., Huber, B. (ed). Decommissioning of nuclear power plants. Proceedings of a European Conference held in Luxembourg, 22-24 May 1984. Graham & Trotman Ltd, London. **EUR 8655**.

C. Final Contract Reports

Boothby, R M, William, T M (1983). The control of cobalt content in reactor grade steels. European Appl. Res. Rept., Nucl. Sci. Technol., Vol. 5, No 2, Harwood Academic Publishers. **EUR 8655**.

Lörcher, G, Piel, W (1983). Dekontamination von Komponenten stillgelegter Kernkraftwerke für die freie Beseitigung. **EUR 8704**.

Kloj, G, Tittel, G (1984). Thermische und mechanische Trennverfahren für Beton und Stahl. **EUR 8633**.

Harbecke, W, et al. (1984). Die Aktivierung des biologischen Schields im stillgelegten Kernkraftwerk Lingen. **EUR 8801**.

Verral, S, Fitzpatrick, J (1985). Design concepts to minimise the activation of the biological shield of light-water reactors. **EUR 8804**.

Eickelpasch, W, et al. (1984). Die Aktivierung des biologischen Schields im stillgelegten Kernkraftwerk Gundremmingen Block A. **EUR 8950**.

Verry, P, Lecoffre, Y (1984). Décontamination de surfaces par érosion de cavitation. **EUR 8956**.

- Allibert, M, Delabbaye, F (1984). Extraction du cobalt des aciers inoxydables. **EUR 8966.**
- Ebeling, W, et al. (1984). Dekontamination von Betonoberflächen durch Flammstrahlen. **EUR 8969.**
- Boulitrop, D, Rouet, D (1984). Etude de la décontamination au moyen de supports gélifiés. **EUR 9102.**
- Peselli, M (1984). Individuazione quantitativa delle impurezze del contenitore a pressione del reattore del Garigliano. **EUR 9167.**
- Avanzini, P G, et al. (1984). Valutazione delle caratteristiche di progetto che facilitano lo smantellamento delle centrali nucleari PWR. **EUR 9191.**
- Regan, J D, et al. (1984). Design features facilitating the decommissioning of Advanced Gas-Cooled Reactors. **EUR 9207.**
- May, S, Piccot, D (1984). Détermination analytique d'éléments traces dans des échantillons de bétons utilisés dans les réacteurs nucléaires de la Communauté européenne. **EUR 9208.**
- White, I F, et al. (1984). Assessment of management modes for graphite from reactor decommissioning. **EUR 9232.**
- Goddard, A J H, et al. (1984). Trace element assessment of low-alloy and stainless steels with reference to gamma activity. **EUR 9264.**
- Bregani, F, et al. (1984). Chemical decontamination for decommissioning purposes. **EUR 9303.**
- Larcombe, M H E, Halsall, D R (1984). Robotics in nuclear engineering. Graham & Trotman Ltd., London. **EUR 9312.**
- Glock, H -J, et al. (1984). Dokumentationssystem für den Abbau von Kernkraftwerken. **EUR 9343.**
- Ahlfänger, W (1984). Zusammensetzung von Kontaminationsschichten und Wirksamkeit der Dekontamination. **EUR 9352.**
- Brambilla, G, et al. (1984). Vernici per la fissazione della contaminazione superficiale dei materiali. **EUR 9358.**
- Paton, A A, et al. (1984). Civil engineering design for decommissioning of nuclear installations. Graham & Trotman Ltd, London. **EUR 9399.**
- Bittner, A, et al. (1985). Konzepte zur Minimierung der Aktivierung des biologischen Schilfs. **EUR 9442.**
- Brambilla, G, Beaulardi, L (1985). Rivestimenti rimovibili per la protezione di superfici in calcestruzzo dalla contaminazione. **EUR 9463.**
- Arndt, K -D, et al. (1984). Thermisches Trennen von plattierten Komponenten des Primärkreises von Kernkraftwerken. **EUR 9479.**
- Rawlings, G W (1985). Development of large diamond-tipped saws and their application to cutting large radioactive reinforced concrete structures. **EUR 9499.**

Barody, I I, et al. (1985). Treatment of active concrete waste arising from dismantling of nuclear facilities. **EUR 9568.**

Bernard, A, Gerland, H (1985). Recherche et caractérisation de revêtements pour la protection des structures en béton. **EUR 9595.**

De Tassigny, C (1985). Mise au point et essais d'une méthode pour le revêtement de déchets métalliques contaminés, par des résines thermodurcissables. **EUR 9666.**

Migliorati, B, et al. (1985). Smantellamento di componenti metallici e di strutture in calcestruzzo mediante raggio laser. **EUR 9715.**

Fleischer, C C (1985). A study of explosive demolition techniques for heavy reinforced and prestressed concrete structures. **EUR 9862.**

Wieling, N, Hofmann, P J (1985). Erosionskorrosionsversuche mit kobaltfreien Werkstoffen. **EUR 9865.**

Antoine, P, et al. (1985). Intégrité à long terme des bâtiments et des systèmes. **EUR 9928.**

Lewis, G NH (1985). Degradation of building materials over a lifespan of 30-100 years. **EUR 10020.**

Hasselhoff, H, Seidler, M (1985). Anlage zum Einschmelzen von radioaktiven metallischen Abfällen aus der Stilllegung. **EUR 10021.**

Chavand, J, et al. (1985). Découpage de composants métalliques par fissuration intergranulaire. **EUR 10037.**

Gauchon, J P, et al. (1986). Décontamination par des méthodes chimiques, électrochimiques et au jet d'eau. **EUR 10043.**

Smith, G M, et al. (1985). Methodology for evaluating radiological consequences of the management of very low-level solid waste arising from decommissioning of nuclear power plants. **EUR 10058.**

Gomer, C R, Lambley, J T (1985). Melting of contaminated steel scrap arising in the dismantling of nuclear power plants. **EUR 10188.**

Da Costa, L, et al. (1985). Systems for remotely-controlled decommissioning operations. Graham & Trotman Ltd, London. **EUR 10197.**

Price, M S T, Lafontaine, I (1985). System of large transport containers for waste from dismantling light water and gas-cooled nuclear reactors. **EUR 10232.**

Bargagliotti, A, et al. (1986). Plasma arc and thermal lance techniques for cutting concrete and steel. **EUR 10402.**

Lasch, M (1986). Entwicklung von wirtschaftlichen Dekontaminationsverfahren. **EUR 10519.**

Hulot, M, et al. (1986). State-of-the-art review on technology for measuring and controlling very low-level radioactivity in relation to the decommissioning of nuclear power plants. **EUR 10643.**

ANNEX II

LIST OF PUBLICATIONS RELATING TO THE RESULTS OF THE 1984-88 PROGRAMME ON THE DECOMMISSIONING OF NUCLEAR INSTALLATIONS

A. Annual Progress Reports

"The Community's Research and Development Programme on Decommissioning of Nuclear Installations - First Annual Progress Report (year 1985)", EUR 10740, 1986.

"The Community's Research and Development Programme on Decommissioning of Nuclear Installations - Second Annual Progress Report (year 1986)", EUR 11112, 1987.

"The Community's Research and Development Programme on Decommissioning of Nuclear Installations - Third Annual Progress Report (year 1987)", EUR 11715, 1987.

B. 1989 European Conference

Pflugrad, K., et al (ed). Decommissioning of nuclear installations. Proceedings of an international conference held in Brussels, 24-27 October 1989, Elsevier, London, UK. EUR 12690.

C. Final Contract Reports

Janberg, K. (1987). Economic comparison of management modes for contaminated metal scrap. EUR 11149.

Allibert, M. et al. (1987). Séparation par transport en phase vapeur des constituants d'aciers inoxydables. EUR 11296.

Ahlfänger, W. (1988). Vollständige Dekontamination einer Primärdampfleitung des Kernkraftwerks Lingen. EUR 11435.

Ebeling, W. et al. (1989). Untersuchung und Optimierung von Filtersystemen zur Abscheidung von Stäuben und Aerosolen bei der Dekontamination von Betonoberflächen. EUR 11995.

Gray, P W C (1989). The assessment of low-level contamination from gamma-emitting radionuclides. EUR 12183.

Hills, D L (1989). The removal of concrete layers from biological shields by microwaves. EUR 12185.

Lewis, C J A, Vibert, C J T (1989). Adaptation of a robot and tools for dismantling of a gas-cooled reactor. EUR 12186.

Hermanns, B (1989). Entwicklung von Mess-Systemen für Kontaminationsmessungen an räumlich schwer zugänglichen Stellen. **EUR 12236.**

Bishop, A (1989). Ventilation and filtration techniques for handling aerosols produced by thermal cutting operations. **EUR 12321.**

Steringer, A, Moser, T (1989). Auswahl und Entwicklung eines leicht zu verarbeitenden Elektrolyten für die Dekontamination durch Elektropolieren. **EUR 12383.**

Morillon, C, Pilot, G (1989). Décontamination du béton par fusion superficielle à l'aide d'un nouveau brûleur associé à un plasma (étude de faisabilité). **EUR 12489.**

Rouvière, R, et al. (1989). Adaptation des jets d'eau haute pression avec abrasif au démantèlement des installations nucléaires. **EUR 12490.**

Dawson, P, et al. (1989). Pre-stressed concrete reactor vessel with built-in planes of weakness. **EUR 12518.**

Alary, C, et al. (1990). Inventaire des composants activés d'un réacteur à neutrons rapides de puissance. **EUR 12539.**

Bakiewicz, J L, Reymer, A P S (1990). Separation of contaminated concrete. **EUR 12562.**

Jaouen, C (1990). Etude de conteneurs fibro-ciment de grandes dimensions pour déchets solides de démantèlement. **EUR 12563.**

Gasc, B (1990). Extension à la téléopération d'un atelier modulaire étanche pour le démantèlement de composants radioactifs. **EUR 12604.**

Harvey, D S (1990). Research into the melting/refining of contaminated steel scrap arising in the dismantling of nuclear installations. **EUR 12605.**

Haferkamp, H, et al. (1990). Weiterentwicklung des Abrasivstrahl-Schneidverfahrens zum Trennen ferritischer und austenitischer Stähle unter Wasser. **EUR 12684.**

Davis, J P, et al. (1990). Methodology for assessing suitable systems for management of reactor decommissioning wastes. **EUR 12701.**

Pocock, D C, et al. (1990). Long-term performance of structures comprising nuclear power plants. **EUR 12758.**

Deipenau, H, Seidler, M (1990). Cast-iron containers out of low radioactive steel. **EUR 12795.**

Costes, J R, et al. (1990). Conditionnement pour le stockage définitif des briques de graphite radioactif provenant du déclasserement des réacteurs. **EUR 12815.**

Drews, P, Fuchs, K (1990). Development of measuring and control systems for underwater cutting of radioactive components. **EUR 12869.**

de Tassigny, C, Signoret, C (1990). Immobilisation de la contamination par revêtement de polymères sur des déchets radioactifs de grandes dimensions en vue de leur stockage. **EUR 12874.**

Schuster, E, Haas, E W (1990). Behaviour of actinides and other radionuclides that are difficult to measure in the melting of contaminated steel. **EUR 12875.**

Bregani, F, Borroni, P A (1990). Aggressive chemical decontamination tests on small valves from the Garigliano BWR. **EUR 12878.**

Thomé, P (1990). Méthode de coupage de tubes par l'intérieur par scie à l'arc électrique. **EUR 12883.**

Migliorati, B, et al. (1990). Investigation of specific applications of laser cutting for dismantling of nuclear power plants. **EUR 12947.**

Fournié, J L, et al. (1990). Influence des caractéristiques de conception des installations sur le déclassement des Réacteurs à Neutrons Rapides. **EUR 12991.**

Pellecchia, V, et al. (1990). Trattamento "in situ" di superfici in calcestruzzo mediante impregnazione e polimerizzazione con resine organiche. **EUR 13008.**

Buck, S, Colquhoun, A (1990). Decommissioning of a mixed-oxide fuel fabrication facility. **EUR 13057.**

McMahon, T D, et al. (1990). Monitoring gamma radioactivity over large land areas using portable equipment. **EUR 13071.**

ANNEX III

MEMBERS OF THE MANAGEMENT AND COORDINATION ADVISORY COMMITTEE NUCLEAR FISSION ENERGY FUEL CYCLE/PROCESSING AND STORAGE OF WASTE (*)

(during 1990)

<u>BELGIUM</u>	J.P.	HIRSCHBUHLER
	G.	DEDEURWAERDER
<u>DENMARK</u>	K.	BRODERSEN
	T.	NILSEN
<u>FRANCE</u>	J.	LEFEVRE
	L.S.	JOLY
<u>GERMANY</u>	W.	BUSCH
	R.	SCHMIDT
<u>GREECE</u>	S.	AMARANTOS
	G.	KOUTZOUKOS
<u>IRELAND</u>	J.	CUNNINGHAM
	F.	TURVEY
<u>ITALY</u>	F.	MORSELLI
	P.	VENDITTI
<u>LUXEMBOURG</u>	P.	KAYSER
<u>THE NETHERLANDS</u>	H.	CORNELISSEN
	S.	KOOMEN
<u>PORTUGAL</u>	H.J.P.	CARREIRA PICH
	C.	RAMALHO CARLOS
<u>SPAIN</u>	M.	RODRIGUEZ PARRA (Chairman)
	J.	ARANA LANDA
	A.	RODRIGUEZ BECEIRO
<u>UNITED KINGDOM</u>	S.	BROWN
	J.T.	BRITTON
<u>COMMISSION</u>	S.	FINZI
	J.	VAN GEEL

(*) This Committee was established by the Council Decision of 29 June 1984 dealing with structures and procedures for the management and coordination of Community research, development and demonstration activities (OJ N° L 177, 4.7. 1984, p. 25).

European Communities - Commission

**EUR 14227 - The Community's research and development programme on decommissioning of nuclear installations (1989-93).
Annual progress report 1990.**

This is the first annual progress report of the European Community's programme (1989-93) of research on decommissioning of nuclear installations. It shows the status of the programme on 31 december 1990.

This first progress report, covering the period of putting the programme into action, describes the work to be carried out under the 41 research contracts concluded, as well as initial work performed and first results obtained.

