

A Normative Method to Analyse Workarounds in a Healthcare Environment

Motivations, Consequences, and Constraints

Nada Nadhrah¹, Vaughan Michell¹

¹ *Informatics Research Centre, University of Reading, Whiteknights, Reading, UK*

² *Business Informatics, Systems and Accounting Department of Computing, University of Reading, Whiteknights, Reading, UK*
n.nadhrah@pgr.reading.ac.uk, v.a.michell@henley.reading.ac.uk

Keywords: Healthcare IS; Workarounds; Issues; Benefits; Semiotic; Behaviour; Norms; Business; process; Clinical workflow Fitting; Electronic Medication Administration; Patient safety.

Abstract: Healthcare information systems have the potential to enhance productivity, lower costs, and reduce medication errors by automating business processes. However, various issues such as system complexity and system abilities in a relation to user requirements as well as rapid changes in business needs have an impact on the use of these systems. In many cases failure of a system to meet business process needs has pushed users to develop alternative work processes (workarounds) to fill this gap. Some research has been undertaken on why users are motivated to perform and create workarounds. However, very little research has assessed the consequences on patient safety. Moreover, the impact of performing these workarounds on the organisation and how to quantify risks and benefits is not well analysed. Generally, there is a lack of rigorous understanding and qualitative and quantitative studies on healthcare IS workarounds and their outcomes. This project applies A Normative Approach for Modelling Workarounds to develop A Model of Motivation, Constraints, and Consequences. It aims to understand the phenomenon in-depth and provide guidelines to organisations on how to deal with workarounds. Finally the method is demonstrated on a case study example and its relative merits discussed.

1 INTRODUCTION

Healthcare Information Systems (HIS) are important systems that automate and support physicians work processes and are increasingly being adopted in almost all departments within a hospital. These processes supported include optimizing documentation of patient activity, providing communication and access to patient medical information, reduction of medical error, optimizing billing and related settlement payment services, and provide data for research purposes (Kuhn and Giuse, 2000). HIS type systems should enhance the medical decision making process, optimise manual processes and lead to a better prescribing practice. Barriers include high cost, lack of standardization, security and privacy concerns, lack in connection between who pays and who profit from the system (Boonstra, and Broekhuis, 2010; Castillo et al., 2010). However there is also a range of informal factors. Using the system is time consuming (Ash and Bates, 2005; Chaudhry, 2007); it can interfere with the doctor-patient relationship (Boonstra, and Broekhuis, 2010;

Trivedi et al., 2009). Some physicians felt that hospital administration is forcing (Ash and Bates, 2005) adoption of systems regardless of contextual factors relating to physicians' concerning follow the medical guidelines (Trivedi et al., 2009).

Other human social factors which may lead to unwillingness to use a system were neglected by researchers or were briefly mentioned such as organizational related; structure and culture readiness to change (Ash and Bates, 2005; Horan et al., 2004). Some Physicians cite negative perceptions, for example that using the system will threaten their professional autonomy (Moxey et al., 2010), and (Chaudhry, 2007; and Walsh, 2004), and perceived negative impact on their workflow, physicians felt a paper based prescribing is faster (Poon et al., 2004), Personal beliefs also play a part such as, lack of belief in the system benefits and need for personal control of actions, not system control (Boonstra, and Broekhuis, 2010). Moreover, some studies have shown that physicians will not use a system if it interferes with their workflow, changes their practices (Moxey et al., 2010; Poon et

al., 2004). Given these perceived threats and concerns of the imposition of a system, numerous clinicians have found their way to overcome these obstacles by creating alternative ways to get the job done via an alternative process or workaround (Kobayashi et al., 2005; Niazkhani et al., 2011; Saleem et al., 2011).

The imposition of systems has led to unintended consequences and can increase the resistance to their use by users (Lapointe and Rivard, 2005). Other factors driving the search for alternatives to systems use include; inefficient process design, poor system usability, inadequate user training, and inflexible clinical guidelines (Halbesleben et al., 2008; Vogelsmeier et al., 2008) However, whilst satisfying the needs of the clinician, workarounds can have possible negative impacts on patient safety. A workaround sometimes leads to violations or deviation from a safe operating policy and procedures. As a key objective of implementing HIS, is to support these patient safety standards i.e., reducing medication error, this is counterproductive (Zhou et al., 2011; Runciman et al., 2007). On the other hand, workarounds can have positive impacts. Some workarounds are developed because they save the clinician users' time, to enable more focus on patient needs (see Appendix SN4). Despite the occurrence of workarounds in healthcare IS implementations and the potentially severe implications particular to patient safety (Carthey et al., 2009). Previous literature has dedicated little attention to them and there is limited understanding of their impacts on the organization (Nemeth and Cook, 2005).

The paper aims to develop a method that can model the work and workaround process in sufficient detail to measure the actual value of workaround time and effort compared with the original process. We also seek a more robust method to model the workaround behaviour and to understand the motivation and the rules that govern the original process and its workaround. This will enable a more reliable estimate of the true cost and impact of the workaround on clinical processes and patient safety. The remaining sections of the paper first discuss definitions of workaround and the current theoretical background. The motivations, benefits and current issues are identified and the level of classification. We also assess the current empirical models and identify the requirements for our modelling method. We then discuss the application of organisational semiotic and normative methods in conjunction with process modelling and analysis techniques to form a workaround model.

The model is applied to a case study from a Saudi hospital. This model is then used together with an analysis of examples from the literature to extend the classification of workaround process and behaviour features.

2 WORKAROUND DEFINITIONS

The lack of clear definition has added some complexity to the subject (Halbesleben et al. 2008; Kobayashi et al., 2005). Another definition sees workarounds as informal temporary practices developed by users for conducting exceptions to workflow (Niazkhani et al., (2011) and Saleem et al., 2011). This highlights the temporary and informal/voluntary use of the workaround vs. the formal use of the original process prescribed by the organisation.

A workaround is also work patterns that are created by an individual or a group to accomplish a work goal within a system of non-adaptive i.e. dysfunctional work processes that fail to meet task goals (Morath and Tumbull, 2005; Zhou et al., 2011). That definition associates a workaround with work processes that have failed to keep up with changes in expected goals that are supposed to be met from the original work process. This echoes the earlier discussion, where clinicians felt some systems did not support their professional work practices. However, as use of systems is effectively mandated by hospitals part of the workaround may involve using the mandatory system minimally so they are seen to comply whilst focusing their efforts and data on their workaround.

Interestingly none of the definitions include the people driving the workaround or any relationship to the benefit that influences the motivation for the workaround. However, as we have seen workarounds are driven by the motivations of clinical users. Therefore, for our purpose we define a workaround as: 'an alternative work process created by individuals or groups to achieve a benefit over the use of the existing processes.

3 THEORETICAL BACKGROUND

Niazkhani et al (2011) also identified that the formal HIS system process caused rather than cured problems. Cognitive overload on both physicians and nurses was recorded and, information needs and requirements were unmet by HIS, there were order miscommunications and difficult coordination

between co-working professionals in their interrelated tasks, a potential of fault in the administration phase, and poor monitoring of medication plans. Further root cause demonstrated the lack of portable computer devices, poor integration between the paper-based and electronic systems, poor usability of the system, and certain organizational factors in obtaining drugs were a cause. This clearly suggests good reasons for a workaround to HIS. The workarounds created as an alternative to the system included phone calls, using paper forms for taking notes and issuing orders instead of data entry into the system, the use of verbal orders, and modifying and annotating the printed orders.

Rathert et al (2012) demonstrated that work characteristics can influence exhaustion in health care workers, particularly nurses. Based on Halbesleben's (2008) work which highlighted Exhaustion is positively associated with and a driver for workarounds, i.e. nurses may choose a less tiring workaround over the formal system. Also they found that when the physical environment is uncomfortable or inadequate, clinicians may be more likely to 'workaround' perceived blockages in work processes. They assessed the workaround environment quality in terms of noise levels, and temperature) and by equipment working functionality and adequate workspace of the work place.

Unfortunately the work focused on analyzing these problems and workaround behavior created, however, not on the motivations or benefits behind these workarounds. Moreover, in this study there was no direct comparison between the pre-implementation medication processes and workaround processes and their activities. Such analysis is needed to identify the benefits behind these workarounds and the amount of work effort and time to quantify the impact and risk of the workaround. Such information would enable adoption of some of the positive benefits of the workaround or sanctions on the riskier and dangerous aspects of the workaround. It would also enable the business case for investment and improvement in the formal system to obviate the need for the workaround.

3.1 Workaround Motivations, Benefits and Impacts

Workarounds are a manifestation of incompatibilities between Health Information Systems (HIS) and human factors (Lawler et al., 2009). It is important to understand the motivation or cause of workarounds in the context of the

perceived barrier that is being avoided in the original work process and also the structure and activities in the workaround process to appreciate the relative benefits. Motivation has been used in some literature as a way to identify a workaround or to categorize those (Halbesleben et al. 2008). They have suggested that the definition of workarounds should be limited to only those behaviours that violate the original work processes to get the job done, with self-gain a secondary motive. On the other hand, they argue that workaround can be differentiated or categorized based on motive.

Motives can be driven due to error or mistake and shortcut. They differentiate between deviations, where deviance is motivated by factors that include self-gain, whereas, in their view workarounds are primarily motivated by a need to get around a blockage to complete a task (Halbesleben et al. 2008). For example, lack of skills and knowledge about Electronic Health Records (EHR), part of the HIS, and perceived efficacy of paper were motivations to rely on the old paper workaround (Saleem et al., 2009). Whether motive is used as a definition or as a workaround categorization tool, it is important to include motivation in studying workarounds as this drives behaviour, content and the expected benefit of the workaround (Saleem et al., 2011). Also used benefit to define workaround, where workarounds instead of computer use gave benefits of ease of use and flexibility.

Another advantage is that workarounds can sometimes more efficiently or effectively meet a task goal processes (Lawler et al. 2011; Saleem et al., 2011). Often in high-pressure situations workarounds assist work processes to get the job done in a timelier manner, i.e. workarounds can promote work efficiency (Kobayashi et al. 2005; Ferneley and Sobreperez 2006; and Hakimzada et al. 2008). Also as we have seen, workarounds are often an economic practice that addresses systems malfunctions (Varpio et al. 2006; Saleem et al. 2009; and Mohr and Arora 2004).

A workaround can benefit either clinician or patients or both. Participants in a study by Debono et al. (2010) identified some workarounds that benefit only the patient (e.g. breaching protocols to administer required medication to a needy patient), others benefit only the clinician (e.g. overstocking procedure trolleys to reduce effort). But are some other benefits apply to both (e.g. marking non urgent blood test orders as urgent).

Koppel et al. (2008) described the occurrences, causes and threats of workarounds to patient safety. The empirical study observed that patient safety could be compromised by users omitting process steps, performing them out of sequence, or performing unauthorized steps. For example, nurses

sometimes administered medicine without checking the system, to speed up the serving process. Further, they found that workarounds could be driven by technology, organization, patient, task and environment related factors (Koppel et al., 2008).

Assert that motive and beneficiary are important variables needed to be considered when studying workarounds. Workarounds that are superior to some aspects of HIS implementations might be considered as benefits and improvements to poor systems design. For example Niazkhani et al (2011) reported that as soon as physicians entered an order into the HIS, it regenerated a number for the sample, assuming that the sample has been taken from the patient and sent to the laboratory when in fact it has not (Georgiou et al., 2007). This confused the laboratory staff. The existence of the workaround then had a positive benefit and prompted the development of a new procedure to check and cancel these orders after three days (Niazkhani et al., 2011). A qualitative empirical study of part of an HIS, Vogelsmeier et al., (2008), found that workarounds were consistently observed across all nursing homes. These workloads were introduced by staff to counter system workflow blocks that prevented improved medication being entered into the system and threatened patient safety. Hence in this case the motivation was professional and actually benefitted patient safety.

3.2 Disadvantages of Workarounds

Niazkhani et al. (2011), illustrated that unsatisfactory workarounds that include verbal exchange may result in miscommunication and adverse impact on the patient. Also manual documentation in workarounds is more prone to error controlled data entry offered by HIS.

Intentional technical blocks are system processes that force a specific set of data input and raise alarms if not followed to protect patient safety. Some workarounds are created to avoid these sometimes inconvenient and time consuming alarms. This can be an advantage or a disadvantage depending on whether the physician has superior or inferior knowledge and/or workaround motive. Unintentional blocks are caused by poor technology design, e.g. fixed system medication dosage requirements can be dangerous or inefficient and hence workarounds can be more efficient and beneficial as they are more flexible and up to date (Vogelsmeier et al., 2008). However, workarounds to both types of blocks can have negative impacts as data entry may be delayed or forgotten.

As seen above, much work has been done on motivations and benefits and classifications relating to these. Previous studies, either conceptual or empirical, on workarounds, whilst they are helpful to describe the nature of workarounds, they are limited. There limitation is in the focus on general descriptions, lack of a model to compare the original process and workflow to the workaround process, and express the different types of behaviour. There is also a lack of qualitative understanding about the effects of workarounds on the impact of Healthcare Information System (Nemeth and Cook, 2005; Halbesleben et al., 2008). Therefore, this study aims to investigate this gap based on workaround concepts from the IS literature.

4 WORKAROUND CONCEPTUAL MODEL

To provide a more structured qualitative and quantitative comparison and understanding of the workaround process vs. the original process and its impact and benefits we use the previous discussion to develop a workaround conceptual model. We define the original formalised process required by the healthcare organisation as the work process 'WP' with a defined goal 'G'. We define the informal workaround process as WA. As we have seen, each workaround has a problem that prevents WP from being carried. This problem is temporarily resolved as a result of a motivation by the workaround agents to seek an alternative process 'WA' where the workaround actor is an individual that participates in a workaround. The workaround process has a benefit to the agent(s) that is greater than the threat of sanctions or constraints. We define the workaround driver as the motivation to

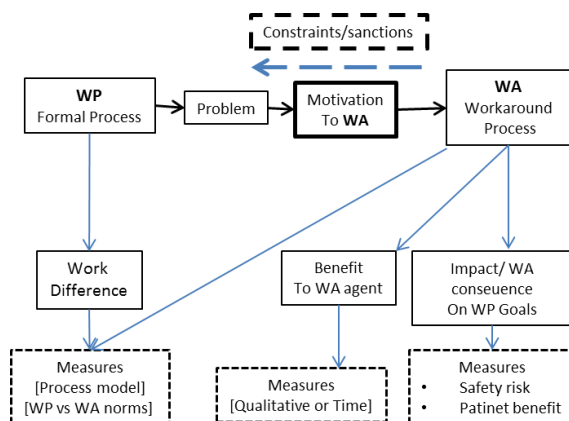

Fig 1: Workaround Conceptual Model

perform the workaround and in specific cases there may be a driving resource (Michell, 2011) that manages and drives the workaround. As the WA is different in terms of the activities, workload and timings compared to the WP we need to consider and measure these factors in order to qualify and quantify the impact in terms of safety risk. We also need to consider the beneficiary e.g. the workaround agents, the patient, the organisation.

5 METHODOLOGY

5.1 Behaviour Modelling Using ‘Organisational Onion’

Workarounds can be most usefully studied from the perspective of human behaviour as it influences motivation to ‘workaround’ behaviour and consequently the workaround process. We apply the theories of Organisational semiotics (Stamper and Liu, 1994) as these enable the study of work systems at three levels (Stamper et al., 2000). These three levels were identified by Liu, (2000) as formal, informal, and technical layers which known as ‘Organizational Onion’. Organisational onion (Liu, 2000) enables us to identify the formal level as the policy and procedures of the hospital that guidance the formal work process WP, the informal level where human social interaction creates and drives the informal workaround process WP, and finally the technical level of automated systems that support the formal level and finally.

5.2 PROCESS MODELLING

To enable the comparison and measurement of WA compared to WP in detail we propose a process modelling approach. Various methods have been used for process modelling. (PM86), but we require to model both the actors and the specific formal, informal and technical activities. We also require modelling the effort and time taken in both WP and WA as effort/exhaustion is a known driver of WA. For this reason a cross function process map using swim-lanes based on Business Process Modelling Notation (BPMN) is used (Owen, et al., 2003; and White, 2004). We apply process time analysis methods (Fasth et al., 2008) to identify cycle times and any waiting times that affect WP and WA. We employ work effort analysis methods to identify the effort in for example man hours to enable

comparisons between the formal WP and the informal workaround WA (Khaswala, and Irani, 2001). We also apply value stream analysis (Bahensky and Bolton, 2004) and 6 Sigma analysis methods (Fairbanks, 2007) to identify any actions in both WP and WA that do not add value to the organisation or client e.g. patient or process goals G mentioned earlier.

5.3 Norm Analysis

Any process is governed by a series of rules that define what to do and when. As most process are human driven, these rules can be considered as norms. Norms are an invariant repertoire of human rules. They also define how the interaction and control between social organisms occurs (Liu et al., 2000). In human processes the human may be obliged to take an action but may not actually carry it out i.e. the rule is deontic (optional) unlike a deterministic computer system that must or must not conduct an action (Stamper et al., 2004). In normative behaviour and reasoning, the deontic logic has traditionally been used to analyse these rules. The deontic constructs of organisational semiotics and Norm analysis (Liu, 2000) are therefore ideal for the analysis of workarounds. There are different types of norms that can be used to illustrate workaround behaviour. *Behavioural norms*, there are three types of behavioural norm – substantive i.e. a process action, communication norms (rules for human communication) and control norms which control of the performance of any work activity or process w WP to meet its goal ‘G’ (Stamper et al., 2000).

The standard behavioural norm specification (SE4) is:

Whenever <context> (when the norm can be applied)

If <condition>

Then <agent/ norm subject > (e.g. a person or system responsible for taking action)

Is <deontic attitude> (obliged – should/must, or prohibited (must not) is permitted (May))

Towards <action>

For example (see Table 1:SN1)

Whenever <a clinician is using the HIS>

Then <physician>

Is <obliged>

To enter the relevant data into the system

We use the Norm Analysis method (NAM), to identify the process events and norm rules, their triggers and constraints in both the WP and WA

workaround processes. Another part enables stakeholders and their motivation types to be identified. However it should be noted that it is less reliable in identifying the informal norms used in the workaround WA as these are tacit and highly unlikely to be codified and may vary with human whim and learning.

6 INTEGRATED METHODOLOGY

We define our workaround analysis method by combining both process mapping and semiotic approaches. This method enables the effort in both WP and WA to be measured, the rules driving both processes and the motivations. This involves using interviewing materials available in the literature for both formal WP actors and WA actors and the following steps:

1. Identify the formal work process WP and informal workaround process WA.
2. Identify stakeholders in WP and WA.
3. Develop cross-functional process maps of WP and WA.
4. Identify the effort and time taken in both WA and WP.
5. Using NAM identify the formal norms in WP and informal norms governing the workaround process WA.
6. Identify the motivation, driver and constraint norms and sanctions.
7. Identify the overall cost and risk.

6.1 Example Case

This section shows how the method can be applied to an example. The example is based on a structured interview case study of a workaround at a public hospital in Saudi Arabia. The case concerns a workaround to an HIS implementation problem. Due to limited space we will use other workaround examples from the literature to illustrate appropriate points at each stage of the method

Step 1 is to identify the formal and informal layers. The work process involved a consultant examining patients as part of his rounds and then entering data into the HIS. The workaround process was devised by the consultant when he was not physically able to be present to examine the patient (meeting the formal layer requirement). He developed an informal process using a junior doctor to conduct the examination and an interest use of a smart phone application to ensure he had a good visible set of information to enable his perceptive,

cognitive and evaluative norms to make a judgement on treatment (informal layer).

After the work process and the workaround were identified (step1) the stakeholders need to be identified. From the example we have a consultant, patient and a computer system the HIS as the only stakeholders in the work process. In contrast the workaround involves an additional process actor, the junior doctor and a different communication application 'What's App'. What's App is a cross-platform mobile messaging app which enables the exchange of messages, photographs, text and voice notes without having to pay for SMS (<http://www.whatsapp.com/>).

In step 3 the cross functional process map figure 4 above shows the different stakeholders and their activities. In step 4 we also identify the different cycle times and waiting times and the different amount of work effort in terms of time. We note that WP involves three steps but varies in time depending on the physician's perception and evaluation of the patient status and his cognitive norms and knowledge. However, the workaround includes two, far more complex stages (WA1/2) with many more activities. WA1 involves the junior doctor – JD examining the patient and writing texts and sending pictures to the consultant to communicate the patients state and medical condition. The consultant ensures that with more complicated cases the text and pictures are sent whilst the JD is still with the patient to enable additional evaluation and knowledge of the consultant to be used by the JD to capture more relevant information and ensure a higher quality evaluation. However the benefit is clearly not just for the JD, the consultant is clearly thinking about the patient and ensuring a timely diagnosis and perhaps helping to train the JD whilst fully supported, although at a distance.

This interestingly shows that some workarounds are not just done to save time and actually may take longer, if it is still in the best interests of the actor (as in Table 1 case number SN1). In this case the actor's professional obligations are driving the workaround. Moreover, the number of the steps involved in the WP are less than the number of the steps in WA. Both processes are to achieve the same goal, of assessing the patient's condition and defining appropriate treatment. We would ideally need to measure the average time and work effort for each step in both the original and WA processes to provide an accurate estimation of the different workload and timescales in both WP and WA1/2. Also we would need to check the variation in activities and complexity, but this was an isolated case to illustrate the method and hence further studies are required.

Process name: WP Saudi case study Consultant examine patient and perform HIS data entry

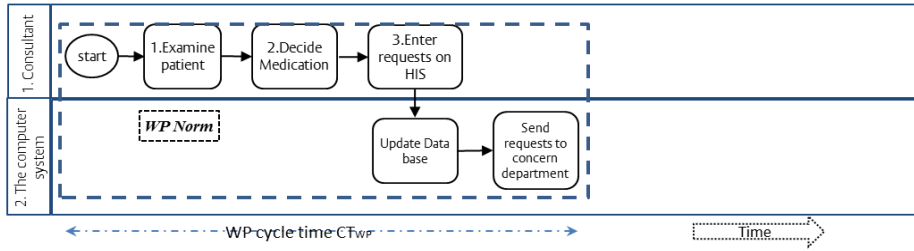

Process name: WP Saudi case study - Consultant workaround (WA1+WA2) when not present

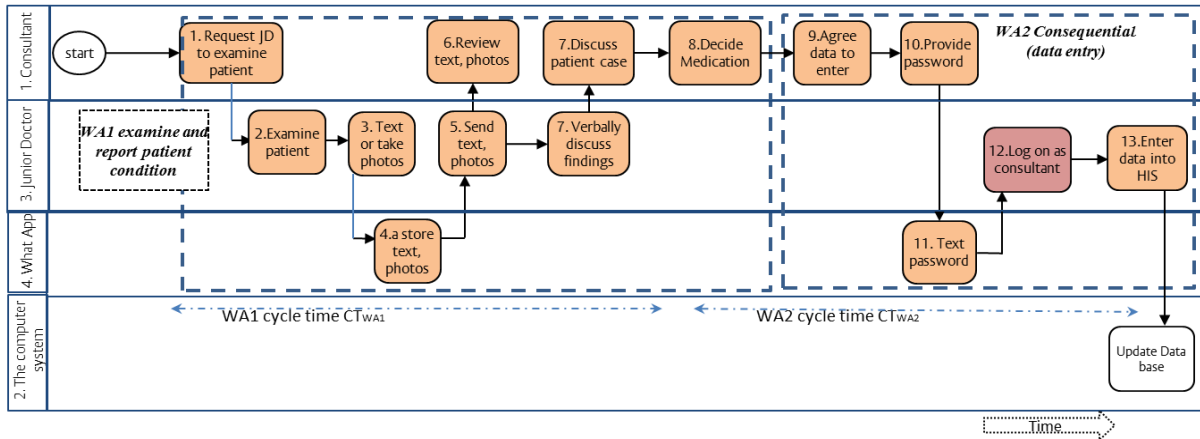

Figure 2: Workaround for WP Saudi case Study

6.1.1 Norm Analysis

In step 5 we use NAM to identify the critical WP norms and the informal norms relating to the workaround WA1 and WA2 (see Table 1). The WP represents the formal layer that the consultant is obliged to follow to perform the process through the system. However, the consultant is often not able to be present and hence the patient either waits or the consultant is motivated to find a workaround. The behavioural norm motivating the workaround action is defined as the driver norm that the process actor uses to decide to deviate from the process. Table 2 shows the formal norm obliging the physician to follow WP, and also the informal WA driver norm that or rule that he uses to ask the JD to follow an alternative workaround process.

We also give an example of an informal norm in the workaround process set up by the physician. In this case the physician specifies the use of 'what's app' to provide a fast and easy to use method of communicating the patient information. We note that once the medication has been specified and agreed for the patient an additional or consequential workaround process is required to get the data into

the formal system to meet the original and valid WP goal.

| Table 1 | Norm Specification |
|-----------------------|--|
| WP Norm | Whenever consultant conducts patient rounds |
| | Then consultant |
| | Is obliged To enter examine patient and enter findings into HIS |
| WA Driver Norm | Whenever consultant is not able to see patient |
| | Then consultant |
| | might ask JD To use examine the patient |
| WA Process Norms | Whenever JD communicates patient examination results |
| | Then consultant |
| | Is obliged to use (What's App) by consultant To use (What's App) to communicate patient information |
| Consequential WA Norm | Whenever consultant JD performs workaround |
| | Then consultant |
| | Is obliged To give user name and password to enable data entry |

In WP2 the consultant is obliged to give the JD his system access so he can enter the medication data on the consultant's behalf. Our workaround process and norm analysis must ensure that all stakeholders and their roles and actors in the workaround are understood. Note; we have excluded the details of pre and post conditions of the norms for space reasons.

6.1.2 Motivation and Constraint

WA's are driven by WA actors and the benefit value is defined and determined by the WA actors. In Step 6 the motivation for the norms any sanctions and constraints and reasons for overriding them need to be established from interviews with the actors The driver of the workaround can be clearly seen to be the consultant as he drives the JD to carry out the agreed informal workaround steps. The beneficiary of the workaround is mainly the patient as waiting time is saved for the patient. Also the JD benefits by potential increased experience. Safety is somewhat managed by providing the benefit of pictures, notes and voice communication. However, there are constraints, as the consultant violates the hospital norm of not giving away his password. The consultant's evaluative norm suggests the benefit to the patient is greater and hence drives the workaround.

6.1.3 Benefit and Risk Analysis

We establish the overall benefit of the workaround by identifying and comparing the work time and effort for WP and WA in man hours or by the number of steps and actors involved establishing the same goal. Clearly the workaround effort $WA1+WA2$ effort \gg WP. However although data entry work is less for the consultant the work involved in managing the JD and checking the data may also be greater. The key benefit of saving patient time and training the JD and extending the working time of the consultant seems to override this. The risk of the workaround is particularly important in the medical area of patient safety. In this case there may be a risk to patient information confidentiality and also of misdiagnosis if the JD perhaps fails to send all the information.

7. WORKAROUND PROCESS STRUCTURES

The case study above and the earlier workaround examples enable us to identify four new process structures

that are used in workarounds. First, we define a simple workaround as a workaround with a continuous workaround process and one owner or driver (see Table 1: SN2). Second, a compound workaround is a workaround with two or more distinct sub-processes as in the example case SN3/A-B. Often there is a primary workaround that leads to another workaround in a separate process with a separate owner in order to achieve the original WP goal. (E.g. nurse having to scan one medicine package multiple times to meet the required dose (Table 1: SN5-A, B).

In some cases the impact of one workaround implicitly forces a normal process agent to create a new workaround in order to convert the output of a previous workaround back to the form required by the original work process and meet the WP goal G. For example SN1-A, B is a good illustration, where a nurse transcribes the data back into the original system that should have been transcribed by the pharmacist.

7.1 Motivation: Driven vs. Self-Motivated Workaround

The examples suggest that there is a difference between a workaround that is driven by a person in authority asking subordinates to perform the workaround (Table 1: SN1-A, B), and a workaround that is driven by the users of WP and executed by the same people. We therefore define a self-motivated workaround as a workaround which is mutually agreed by all the workaround as distinct from the driven workaround. See example (Table 1: SN1-A, B) vs. a self-motivated compound workaround that is motivated and driven by the process actor physician (Table 1: SN5-A, B).

8. CONCLUSIONS

We have explored a range of current literature on workarounds. We have identified that whilst there are many examples of workarounds and a number of models describing the type and behaviour there is no framework for capturing both the social aspects of behaviour and motivation and the means to measure the effort and benefit involved. We have developed an integrated method based on organisational semiotics, norm analysis and process mapping to enable the identification of these features and hence qualitatively and quantitatively evaluate both the mechanism and benefits/risk involved in the workaround. This enables more specific comparison of the outcomes of the workaround to enable either

adoption as a formal process or the development of countermeasures to prevent dangerous workarounds. We have also developed a number of workaround process structures that enable us to reliably describe the form of the workaround and how it is managed. Such an analysis also has sufficient detail to identify what is wrong/ missing with the formal system and process design. Further work has started on gathering further case studies to enable further detailed process models to be developed and also data to understand and quantify the average times and work effort involved in repeated workarounds. Other examples are being collected to determine additional types and motivations for workarounds. The impact on patient safety and related factors will also be addressed and modelled.

9. REFERENCES

- Ash, J. and Bates, D. (2005) 'Factors and forces affecting EHR system adoption: report of a 2004 ACMI discussion'. *Journal of American Med Inform Assoc.*, 12, pp. 8–12.
- Bahensky, J. A., Roe, J. and Bolton, R. (2005) 'Lean Sigma— Will It Work for Healthcare?'. *Journal of Healthcare Information Management*, 19, pp.39-44.
- Boonstra, A. and Broekhuis, M. (2010) 'Barriers to the acceptance of electronic medical records by physicians from systematic review to taxonomy and interventions'. *BMC Health Services Research*, 10 (231), pp. 1-17.
- Castillo, V., Martínez-García, A., and Pulido, J. (2010) 'A knowledge-based taxonomy of critical factors for adopting electronic health record systems by physicians: a systematic literature review'. *BMC Med Inform Decis Mak.* 10 (60).
- Chaudhry, B. (2007) 'Computerized clinical decision support: will it transform healthcare?'. *J Gen Intern Med* 2007, 23(1), pp. 85-87.
- Debono, D., Greenfield, D. Black, D. and Braithwaite, J. (2010) 'Workarounds: straddling or widening gaps in the safe delivery of healthcare.' In *Conference Proceedings of Mind the Gap. The Seventh Biennial Conference in Organisational Behaviour in Health Care*, pp. 11-14.
- Fairbanks, C. B. (2007) 'Using Six Sigma and Lean Methodologies to Improve OR Throughput'. *Aorn Journal*, 86, pp.73-82.
- Fasth, Å., Stahre, J. and Dencker, K. "Analysing changeability and time parameters due to levels of Automation in an assembly system." In *Proceedings of the 18th conference on Flexible Automation and Intelligent Manufacturing-FAIM*. 2008.
- Ferneley, E., and Sobrepey, P. (2006) 'Resist, comply or workaround? An examination of different facets of user engagement with information systems.' *European Journal of Information Systems*, 15, 345-356.
- Georgiou, J. Westbrook, J. Braithwaite, R. Iedema, S. Ray, R. Forsyth, et al. (2007) 'When requests become orders—a formative investigation into the impact of a computerized physician order entry system on a pathology laboratory service', *Int. J. Med. Inform.* 76, pp.583–591.
- Hakimzada, A. F., Green, R. A., Sayan, O. R., Zhang, J. and Patel, V. L., (2008), 'The nature and occurrence of registration errors in the emergency department', *International Journal of Medical Informatics*, 77(3), pp.169 175.
- Halbesleben, Jonathon RB, Douglas S. Wakefield, and Bonnie J. Wakefield. "Work-arounds in health care settings: Literature review and research agenda." *Health Care Management Review* 33, no. 1 (2008): 2.
- Khaswala, Z. N., and Shahrukh, A. I. "Value network mapping (VNM): visualization and analysis of multiple flows in value stream maps." In *Proceedings of the Lean Management Solutions Conference*. 2001.
- Kobayashi, M., Fussell, S. R., Xiao, Y. and Seagull, J. (2005) 'Work Coordination, Workflow, and Workarounds in a Medical Context'.
- Koppel, R., Wetterneck, T., Telles, J. L. and Karsh, B.-T. (2008) 'Workarounds to Barcode Medication Administration Systems: Their Occurrences, Causes, and Threats to Patient Safety'. *J Am Med Inform Assoc.*, 15, pp.408–423.
- Kuhn, K. A., and D. A. Giuse. "From hospital information systems to health information systems." *Methods of information in medicine* 40, no. 4 (2001): 275-287.
- Lalley, C. and Malloch, K. (2010) Workarounds: The Hidden Pathway to Excellence.
- Lapointe, L. and Rivard, S. (2005) A multilevel model of resistance to Information Technology Implementation. *MIS Quarterly*, 29, pp.461-491.
- Lawler, E. K., Hedge, A. and Pavlovic-Veselinovic, S. (2011) 'Cognitive ergonomics, socio-technical systems, and the impact of healthcare information technologies'. *International Journal of Industrial Ergonomics*, 41, pp.336-344.
- Michell, V., A focussed approach to business capability. First International Symposium on Business Modelling and Software Design BMSD Bulgaria pp105-113. 2011.
- Mohr, J. and Arora, V., (2004), 'Break the Cycle: Rooting out the Workaround', *ACGME Bulletin*, Nov, 6-7.
- Morath, J. and Turnbull, J., (2005), *To Do No Harm*, Jossey-Bass A Wiley Imprint, San Francisco.
- Moxey, A., Robertson, J., Newby, D., Hains I., and Williamson, M., (2010) 'Computerized clinical decision support for prescribing: provision does not guarantee uptake', *J Am Med Inform Assoc*, 17, pp. 25–33.
- Nemeth, C.P., O'Connor, M., Nunnally, M. and Cook, R.I., Re-presenting reality: the human factors of health care information, in: P. Carayon (Ed.), *Handbook of Human Factors and Ergonomics in Health Care and Patient Safety*, Lawrence Erlbaum Associates, Mahwah, NJ, 2007, pp. 439–455.

- Niazkhani, Z., Pirnejad, H., Sijs, H. V. D. and Aartsa, J. (2011) 'Evaluating the medication process in the context of CPOE use: The significance of working around the system'. *international journal of medical informatics*, 80, pp.490–506.
- Owen, M. and Raj, J. (2003) BPMN and Business Process Management, Popking Software.
- Poon, E., Blumenthal, D., Jaggi, T., Honour, M., Bates, D. and Kaushal, R. (2004) 'Overcoming barriers to adopting and implementing computerized physicians order entry systems in U.S. hospitals', *Health Affairs*, 23(4), pp.184-190.
- Rathert, C., Williams, E. S., Lawrence, E. R. and Halbesleben, J. R. B. (2012) 'Emotional exhaustion and workarounds in acute care: Cross sectional tests of a theoretical framework'. *International Journal of Nursing Studies*, 49, pp.969–977.
- Runciman, B., Merry, A. and Walton, M., (2007), *Safety and Ethics in Healthcare A Guide to Getting it Right*, Ashgate Publishing Limited, Hampshire.
- Stamper, R., Liu, K., Hafkamp, M. and Ads, Y. (2000) 'Understanding the role of signs and norms in organisations'. *Journal of Behaviour and Information Technology*, 19, pp.15-27.
- Stamper, R. and Liu, K. Organisational Dynamics, Social Norms and Information Systems. *In Proceeding of the Twenty-Seventh Hawaii International Conference*. Twente Univ., Enschede, Netherlands. 1994.
- Stamper, R., Liu, K., Sun, L., Tan, S., Shah, H., Sharp, B. and Dong, D. Semiotic Methods for Enterprise Design and IT Applications. *In Proceeding of the 7th International Workshop on Organisational Semiotics*. 2004.
- Trivedi, M., Daly, E., Kern, J., Grannemann, B., Sunderajan, P., and Claassen, C (2009) 'Barriers to implementation of a computerized decision support system for depression: an observational report on lessons learned in "real world" clinical settings'. *BMC Medical Informatics and Decision Making*, 9 (6).
- Varpio, L., Schryer, C. F., Lehou, P. and Lingard, L. (2006) 'Working Off the Record: Physicians' and Nurses' Transformations of Electronic Patient Record-Based Patient Information'. *Acad Med.*, 81, pp.35-39.
- Vogelsmeier, A. A., Halbesleben, J. R. B. and Scott-Cawiezell, J. R. (2008) 'Technology Implementation and Workarounds in the Nursing Home'. *J Am Med Inform Assoc.*, 15, pp.114–119.
- Walsh S., (2004) 'The clinician's perspective on electronic health records and how they can affect patient care'. *British Medical Journal*, 328(7449), pp. 1184-1187.
- White, S. A. "Introduction to BPMN." *IBM Cooperation* (2004): 2008-029.
- Yang, Z., Ng, B., Kankanhally, A. and Luenyip, J. W. (2012) 'Workarounds in the use of IS in healthcare: A case study of an electronic medication administration system'. *Int. J. Human-Computer Studies*, 70, pp.43–65.
- Zhou, X., Ackerman, M. S. and Zheng, K. (2011) 'CPOE Workarounds, Boundary Objects, and Assemblages'. 7-12.

APPENDIX

Table 1: Workaround cases from literature.

| SN | Work process | Problem | Motivation to Workaround | Workaround process | Impact on WP goals/consequence (risks) | Types of WA processes | Source |
|-----|--|---|---|--|--|--|-------------------|
| 1-A | Physicians must enter data into HIS system to order any patient analysis and tests | Physicians not familiar with system | Use more familiar paper based solution he is familiar with. | Physician enters data onto pre-system paper-based sheet to order the patient analysis | Extra work, wasted nurse time | Consequential workaround with driven motivation: WA1.a-Physician drives WA1.b i.e. nurses must transcribe patient orders into the system if it was found on a paper | Yang et al., 2012 |
| 1-B | Physicians obliged to use computer on wheels (COW) to enter notes | COW may not be at bedside, not charged (due to space) | Obtaining a working charged COW takes valuable patient time | If cow not available physician writes manual notes. Manual notes need to be transcribed | Extra work, wasted nurse time | Consequential workaround-Physician or nurses must transcribe the data into the system if it was found on a paper | Yang et al., 2012 |
| 2 | Physician must enter valid data into system fields | Entering valid data takes more time | Entering N/A in some fields (check) achieves the same result with less time | Physicians filling up "N.A" in several fields to get around the requirement | Increased medication errors due to wrong dose and/or route served. | Simple workaround | Yang et al., 2012 |
| 3-A | To order medication for a patient, physician must enter the details of the dose. Enter 'Dose' in numbers. | Prescribing certain orders that were often very intuitive with natural language but difficult with the structured format prescription required by the system. | Because the box allowed free-text, this convenience fitted well with doctors 'order practices inherited from previous paper-based operations. | Doctors started to rely on the comment box to prescribe certain complicated orders. | Resulted in missing and misplaced orders. | Consequential workaround with driven motivation: WA3.a-Physicians deliberately (drives) insert the order in the free text WA3.b i.e. pharmacist must place the order in the right slots to be processed. | Zhou et al., 2011 |
| 3-B | Medication orders always need to be verified by pharmacists and then executed by nurses. | When an order was placed in comment box | To complete the order that was not completed right by physicians. | Pharmacists may spot the message, and then they re-prescribe it and place it in the right place. | Extra work, wasted pharmacist time | Consequential workaround pharmacist must place the order in the right slots to be processed. | Zhou et al., 2011 |
| 4 | Physicians obliged to log-in into their account to order any analysis or medication for patients which increases the accountability | Failure of previous users to log out from the system after use Slowness of log-in process leading to sharing of account | Sharing someone else's already active log in reduces time to log in/out Faster to accomplish certain activity. | Physicians shared log in account/use account of who is already logged in. | Decreases accountability. Enhances the activity speed | Simple workaround | Yang et al., 2012 |
| 5-A | Pharmacist should create orders for medications in the systems when needed exact dose order is not available, pharmacist should prepare medications for scanning, and should provide the exact medication dose needed for the order. | Hospital policy may not fit with the system procedures, e.g., pharmacist should prepare the medicine dose that fit the order but they are not. | Hospital policy may not fit with the system procedures | Pharmacist does not prepare the exact required dose and sent multiple medication packages. | Extra work, wasted nurse time | Compound workaround self-motivated: WA5.a-Pharmacist followed the hospital procedure which lack consistency with HIS procedure. | Zhou et al., 2011 |
| 5-B | Nurse has multiple med packages for full dose and scans the same med package multiple times (to avoid multiple scans for same operation (e.g., several tablets for one dose). | Viewed as another's job | Hospital policy may not fit with the system procedures | A nurse has multiple medication packages to deliver a full dose of medication and scans one of the packages multiple times instead of scanning each package. | Extra work, wasted nurse time | Compound workaround self-motivated: | Zhou et al., 2011 |