

REVIEW AND EXTENSION OF THE McCABE-THIELE METHOD COVERING MULTIPLE FEEDS, PRODUCTS AND HEAT TRANSFER STAGES

A. Marcilla, M.D. Serrano and J.A. Reyes-Labarta

Abstract

The McCabe-Thiele method is a classical approximate graphical method for the conceptual design of binary distillation columns which is still widely used, mainly for didactical purposes, though it is also valuable for quick preliminary calculations.

Nevertheless, no complete description of the method has been found and situations such as different thermal feed conditions, multiple feeds, possibilities to extract by-products or to add or remove heat, are not always considered.

In the present work we provide a systematic analysis of such situations by developing the generalized equations for: a) the operating lines (OL) of each sector, and b) the changeover line that provides the connection between two consecutive trays of the corresponding sectors separated by a lateral stream of feed, product, or a heat removal or addition.

1. Introduction

Multistage distillation is the most widely used industrial method for separating chemical mixtures with high energy consumption especially when the relative volatility of the key components being separated is lower than 1.5. In this sense, many references dealing with the optimal design of binary distillation columns, describe the McCabe-Thiele method, that although less rigorous than the Ponchon and Savarit method is nevertheless

most useful for initial calculations, since it does not require detailed enthalpy data by assuming the condition of constant molar overflow (CMO).

Furthermore, the optimum point of feed introduction, which yields the least total number of trays at a particular reflux, is generally considered as the intersection point between the operative lines of the sector above and below, in order to use always at each step, the operative line that lies farther from the equilibrium curve to obtain the maximum enrichment per stage (i.e. lowest vapor composition if we start at the top of the column). Therefore, when a mass feed stream is considered, whatever its thermal condition q_F [2, 4, 6-11], such optimum feed location consideration is consequent with the assumption that the feed is introduced in bulk to a single tray where it mixes with the vapor of the tray below and with the liquid of the tray above. The streams leaving this feeding stage are considered to be in equilibrium, as in any other theoretical stage (Figure 1a).

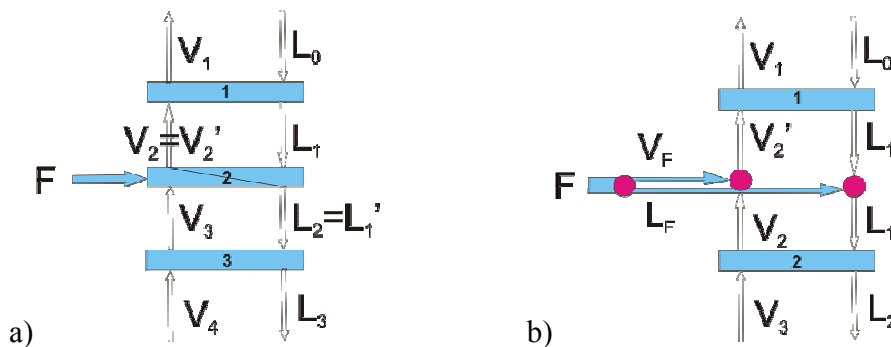

Figure 1. Scheme of the streams at the zone connecting two consecutive sectors using a) the classical FP approach; b) the FOL approach.

However, this approach can be somewhat far from the physical reality, that does not allow to exactly locate all the streams involved in the changing zone of two consecutive

sectors in the McCabe-Thiele diagram, and that can introduce some significant deviations in the equilibrium compositions obtained for the different trays of the column below each particular feed, especially in systems of high relative volatility and when the feed is a subcooled liquid, a partly vaporized mixture or a superheated vapor. Thus, it is more likely to consider that when a feed stream is introduced in the distillation column, it flashes adiabatically and spontaneously to the feed stage pressure, generating a vapor phase (V_F) that flows to the tray immediately above, and a liquid phase (L_F) that flows to the tray immediately below (Figure 1b) [2, 6].

Nevertheless, in many cases, the separate introduction of the liquid and vapor feed portions is considered to have a small influence in the calculations of the theoretical number of trays, and therefore the classical approach may be a sufficient approximation for an already approximate method such as the McCabe-Thiele one, taking into account additionally that in the final design it is necessary to apply the efficiency of the equilibrium trays [6, 8, 13]. Consequently, the equation that defines the actual change between two consecutive sectors in a column (feed operative line) is not usually developed and the stage of such change of sector is not represented, presenting an ambiguous analysis of the feed zone [1-22]. In this sense, Lenadois and Olivera-Fuentes [23] studied the use of the feed operative line for distillation of a two-phase feed stream, coherently solving this problem by the McCabe-Thiele and Ponchon-Savarit methods.

Thus, the objective of this paper is to point out and analyze, the application of the McCabe-Thiele Method using generalized equations for the Operative Lines for the different sectors in a column having multiple feeds, products and/or heat removals or

additions, as well as the corresponding generalized Changeover Lines for the changes between consecutive sectors due to different side streams.

Finally it is interesting to remark that the tray by tray methods present some attractive characteristic for the more effectively and optimal design of separation units such as their robustness due to the fact that the convergence for a feasible postulated separation is almost always guaranteed, and a near optimal design is obtained at each iteration. Additionally some references can be found in the literature dealing with transformation of variables, such as composition, so that the McCabe-Thiele method becomes applicable in special cases of traditional distillation, reactive distillation, absorption, liquid-liquid extraction and multicomponent mixtures [6, 11, 24-36]. The extension of the McCabe-Thiele method can also be used to analyze quickly, the effects and drawbacks of different configurations for internal heat integration in a single distillation column (HIDiC), to obtain more suitable chemical processes [37-40].

2. McCabe-Thiele method review

The McCabe-Thiele method for the conceptual design of binary distillation columns is an approximate graphical method based on the combination of material balances and equilibrium to calculate for a given binary mixture and column operating pressure, the number of equilibrium stages or reflux for a desired degree of separation of the feed components. This method accepts the following simplifications [11]:

- constant molar latent heat of the mixture; i.e., the molar latent heats of both components in the mixture are equal and constant

- negligible component sensible-enthalpy changes and heat of mixing compared to the latent heat changes (i.e. components with a similar chemical nature and molecular weights)
- adiabatic column, i.e. the column is well insulated so that the heat loss is negligible
- uniform pressure through the column, no pressure drop (if not, the equilibrium curve needs adjustment for pressure variable)

These simplifications can be resumed as identical amounts of energy are required to condensed or vaporize a mole of the mixture, and therefore to substitute the energy balances.

Accepting all these simplifications, the liquid and vapor molar flow rates within each column section are considered constant in each section of the column (condition of constant molar overflow, CMO). Consequently, the graphical method can be implemented in a y/x diagram, where y is the vapor composition and x is the liquid composition in equilibrium, both in molar basis.

The most widely analyzed case is that of a column with a partial reboiler, a total condenser and a single feed. The feed condition is also analyzed in several texts [2, 4, 6-11]. Two OLs are normally calculated, i.e. the upper or rectifying section OL (UOL) and the lower or stripping section OL (LOL). The UOL intercepts the diagonal of the y/x diagram at $x=y=x_D$, and the slope is $L_D/(L_D+D)$ (or the liquid molar flow rate divided by the vapor molar flow rate in the rectifying section), where L_D is the liquid reflux to the column and D is the distillate flow rate of composition x_D . The LOL intercepts the diagonal at $x=y=x_R$ and the slope is the liquid molar flow rate divided by the vapor molar flow rate in the stripping section. The feed line (FL), i.e.: that intercepting the diagonal at $x=y=z_F$, and having the slope of $-q_F/(1-q_F)$, where z_F is the overall composition and q_F is the thermal

condition of the mass feed stream, is also represented in the y/x diagram and the three lines (UOL, UOL and FL) cross each other at the point FP (Figure 6a). This point is normally used as the reference for the graphical step-by-step calculation procedure and the corresponding OL is used alternating with the equilibrium curve to draw the equilibrium stages. Initiating the calculation from the condenser, the UOL is used until a liquid composition calculated is the first below the composition x_{FP} [1-11].

y_F and x_F are the compositions of the vapor V_F and liquid L_F portions, respectively, that are generated when the feed stream with a initial enthalpy of H_F , flashed adiabatically to the feed stage pressure inside the column. Thus, the thermal condition of the feed stream q_F is normally defined as the enthalpy change to bring the feed stream from its initial condition to a saturated vapor divided by the molar latent heat or enthalpy of vaporization of the feed λ_F (dew-point vapor enthalpy, H_F , minus bubble point liquid enthalpy, h_F):

$$q_F = \frac{H_F - H_F}{H_F - h_F} = \frac{H_F - H_F}{\lambda_F} \quad (\text{S.1a})$$

If the feed is a saturated liquid or a saturated vapor, the corresponding value of q_F will be 1 and 0, respectively. In the especial cases of undercooled liquid or superheated vapor, the thermal condition of the feed can be calculated as follows:

$$q_{F(\text{undercooled liquid})} = \frac{H_F - [h_F + C_{PL} \cdot (T_F - T_{\text{boiling point}})]}{\lambda_F} = 1 + \frac{C_{PL} \cdot (T_{\text{boiling point}} - T_F)}{\lambda_F} > 1 \quad (\text{S.1b})$$

$$q_{F(\text{superheated vapor})} = \frac{H_F - [H_F + C_{PV} \cdot (T_F - T_{\text{dew point}})]}{\lambda_F} = \frac{-C_{PV} \cdot (T_F - T_{\text{dew point}})}{\lambda_F} < 0 \quad (\text{S.1c})$$

where C_{PL} and C_{PV} are the specific heats of liquid and vapor, T_F is the temperature of the feed.

3. Generalized equations for the corresponding OLs

Figure 2 shows a generalized distillation column containing equivalent theoretical stages and the nomenclature used to generalize the OLs for each sector. We use two sub-indexes to specify any tray i in any sector of the column (e.g. sector $k+1$, where k is the number of generalized side feed streams that the sector contains). The i tray index increases by one when adding one tray in the same sector, and the sector index increase by one after the addition of each generalized feed. Thus, both indexes increase as we descend through the column (similar deductions could be obtained by ascending). The liquid L and vapor V streams have the sub-indexes of the tray they leave, i.e.: $L_{k+1,i}$ is the liquid flow of composition $x_{k+1,i}$ that leaves tray i of sector $k+1$, $V_{k+1,i+1}$ is the vapor flow of composition $y_{k+1,i+1}$ that leaves tray $i+1$ of sector $k+1$, in equilibrium with $L_{k+1,i+1}$. The column has a partial reboiler (in which liquid from the bottom stage is partially vaporized to give the liquid bottoms product and the vapor boilup that is returned to the bottom stage), a total condenser (in which the overhead vapor leaving the top stage is totally condensed to give a liquid distillate product and liquid reflux that is returned to the top stage) and a number of adiabatic sectors, where the net flows of mass and enthalpy are constant (i.e. without any new mass or heat generalized feed entering the column between any of their corresponding trays). D is the distillate flow of composition x_D , R is the residue flow of composition x_R , and L_D is the liquid reflux to the column.

Two consecutive sectors k and $k+1$ are separated by a generalized feed side stream (GF_k) and we consider that only a single GF_k at the feed stage pressure can be added or removed between two consecutive sectors.

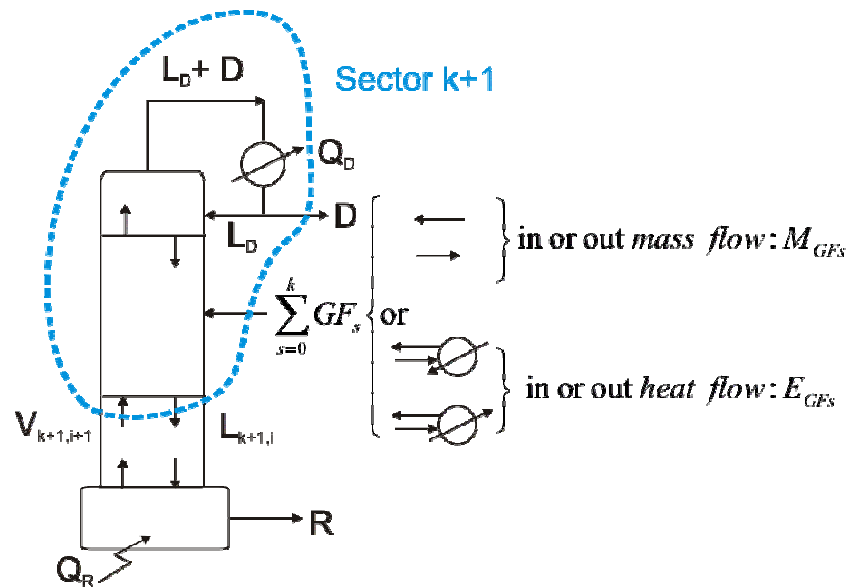

Figure 2. Generalized scheme of a distillation column.

Such a generalized feed stream, GF_k , can be either a mass stream (M_{GFk}) or an enthalpy stream (E_{GFk}), involving different cases:

a) Mass side stream

If GF_k is a positive mass stream, we consider M_{GFk} the *mass flow rate* that is entering the column, z_{GFk} the overall mole-fraction composition, and q_{GFk} the thermal condition [2, 4, 6-11] of such stream, i.e. we are dealing with a *conventional feed* (Figure 3a-e). Such a feed may be a superheated vapor ($q_{GFk} < 0$), a saturated vapor ($q_{GFk} = 0$), a mixture of liquid and vapor in equilibrium ($0 \leq q_{GFk} \leq 1$), a saturated liquid ($q_{GFk} = 1$) or a undercooled liquid ($q_{GFk} > 1$). Obviously, the thermal condition of the feed stream determines the difference between the vapor and liquid flow rates in the corresponding above and below sections of the column.

The corresponding liquid (L_{GFk}) and vapor (V_{GFk}) fractions, of compositions x_{GFk} and y_{GFk} respectively, that generates the feed stream inside the column can be easily obtained by simple flash calculations using q_{GFk} . Note that when $q_{GFk} < 0$ or $q_{GFk} > 1$, for superheated vapor or undercooled liquid (see Supplementary Material), it would be necessary to consider the conversion of sensible enthalpy into latent enthalpy of phase change (Figures 3b and 3c).

If GF_k is a negative mass stream, we are considering a M_{GFk} *product leaving the column* (Figures 4a-b), and we will only consider a liquid in equilibrium product or a vapor in equilibrium product, since they must be streams present in the column (equilibrium streams).

b) Heat side stream

Sometimes intermediate reboilers and/or intermediate condensers are used in distillation columns, normally to adjust an existing distillation column to new separation requirements or feeds. Thus for instance, a wide gap between the component balance line and the equilibrium curve in the stripping section or enriching indicates a potential for an interreboiler or an intercondenser, respectively. Obviously, the intermediate heat supply and/or heat removal causes changes of internal vapor and liquid flows.

Thus, in the case of heat side streams, where there is not a net mass flow in or out the column (i.e., the corresponding M_{GFk} is 0), we consider that E_{GFk} is the *effective heat flow added or removed* to the column by an intermediate heat exchanger (reboiler or condenser that we consider having a 100% efficiency, Figures 5a-b) to a liquid or a vapor stream, respectively. When a liquid stream of x_{GFk} molar fraction is heated, a vapor stream of a flow rate given by $V_{GFk} = E_{GFk} / \lambda_{GFk}$, where λ_{GFk} is the enthalpy of vaporization of the

feed, will be generated. Obviously, such a vapor stream, that has the same molar fraction as that of the liquid it comes from (i.e. $y_{GFk}=x_{GFk}$), will join the vapor ascending from the stage below that where the heat is added.

When heat is removed from a vapor stream of molar fraction y_{GFk} , it will generate a liquid stream of a flow rate given by $L_{GFk} = E_{GFk} / \lambda_{GFk}$ that will join the liquid descending from the stage above where the heat is removed, in a similar way to the previous case.

Considering all these possibilities, the expressions for the vapor and liquid feed portions of the generalized feed $GF_k = V_{GFk} + L_{GFk}$ are expressed as:

$$V_{GFk} = \begin{cases} (1 - q_{GFk}) M_{GFk} & \text{if } GF_k = \text{mass side stream} \\ + E_{GFk} / \lambda_{GFk} & \text{if } GF_k = \text{heat side stream} \end{cases} \quad (1)$$

$$L_{GFk} = \begin{cases} q_{GFk} \cdot M_{GFk} & \text{if } GF_k = \text{mass side stream} \\ - E_{GFk} / \lambda_{GFk} & \text{if } GF_k = \text{heat side stream} \end{cases} \quad (2)$$

As a summary the generalized in or out feed side stream considered (GF_k) and their characteristics and sign are shown in Table 1:

Table 1. Compilation of the different cases presented for a GF_k and its characteristics.

Name	Enthalpy flow rate	Molar flow rate	Thermal condition	Molar fraction (Z_{GFk})	V_{GFk} [molar fraction]	L_{GFk} [molar fraction]
Feed	$M_{GFk} \cdot H_{GFk}$	$M_{GFk} > 0$	$-\infty < q_{GFk} < \infty$	Z_{GFk}	$(1 - q_{GFk}) \cdot M_{GFk}$ [y_{GFk}] _{equilibrium}	$q_{GFk} \cdot M_{GFk}$ [x_{GFk}] _{equilibrium}
Product	$M_{GFk} \cdot H_{GFk}$	$M_{GFk} < 0$	$q_{GFk} = 0$	y_{GFk}	$(1 - q_{GFk}) \cdot M_{GFk}$ [y_{GFk}] _{equilibrium}	$q_{GFk} \cdot M_{GFk}$ [x_{GFk}] _{equilibrium}
	$M_{GFk} \cdot h_{GFk}$	$M_{GFk} < 0$	$q_{GFk} = 1$	x_{GFk}	$(1 - q_{GFk}) \cdot M_{GFk}$ [y_{GFk}] _{equilibrium}	$q_{GFk} \cdot M_{GFk}$ [x_{GFk}] _{equilibrium}
Heat addition	$E_{GFk} > 0$	$M_{GFk} = 0$	--	x_{GFk}	$E_{GFk} / \lambda_{GFk} > 0$ [$y_{GFk} = x_{GFk}$]	$-E_{GFk} / \lambda_{GFk} < 0$ [x_{GFk}]
Heat removal	$E_{GFk} < 0$	$M_{GFk} = 0$	--	y_{GFk}	$E_{GFk} / \lambda_{GFk} < 0$ [y_{GFk}]	$-E_{GFk} / \lambda_{GFk} > 0$ [$x_{GFk} = y_{GFk}$]

Apart from the situations presented in Table 1, other possibilities can be devised for a generalized feed such as simultaneous mass and heat addition or removal, but the bases for their analysis could be clearly stated from the cases considered and extended if necessary. Detailed schemes of the different situations with all the streams involved are described in Section 4.

4. Generalized Operative Line (GOL_k) calculation

Applying the previous considerations and the classical McCabe-Thiele derivation, it is possible to obtain the following expression for the Generalized Operative Line of sector k+1 that includes k generalized feed streams. This OL_{k+1} relates the counterflowing vapor and liquid compositions in sector k+1 (Figure 2):

$$\begin{aligned}
 \text{OL}_{k+1}: y_{k+1,i+1} &= \frac{L_{k+1,i}}{V_{k+1,i+1}} \cdot x_{k+1,i} + \frac{D \cdot x_D - \sum_{s=0}^k M_{GFs} \cdot z_{GFs}}{V_{k+1,i+1}} \quad \therefore \\
 y_{k+1,i+1} &= \frac{L_D + \sum_{s=0}^k L_{GFs}}{L_D + \sum_{s=0}^k L_{GFs} + D - \sum_{s=0}^k M_{GFs}} \cdot x_{k+1,i} + \frac{D \cdot x_D - \sum_{s=0}^k M_{GFs} \cdot z_{GFs}}{L_D + \sum_{s=0}^k L_{GFs} + D - \sum_{s=0}^k M_{GFs}} \quad (3)
 \end{aligned}$$

where $L_{k+1,i} = L_D + \sum_{s=0}^k L_{GFs}$, according to the condition of constant molar overflow. It should be noted that L_{GFs} also introduce the effect of the possible heat side streams (Table 1).

In order to obtain the previous relationship between the composition of a vapor stream ascending from a stage and that of the liquid descending from the next upper stage, a total mass balance between tray i of section $k+1$ and the condenser is written:

$$V_{k+1,i+1} - L_{k+1,i} = D - \sum_{s=0}^k M_{GFs} \quad (S.2)$$

For the more volatile component:

$$V_{k+1,i+1} \cdot y_{k+1,i+1} - L_{k+1,i} \cdot x_{k+1,i} = D \cdot x_D - \sum_{s=0}^k M_{GFs} \cdot z_{GFs} \quad (S.3)$$

Thus, the relation between the molar vapor stream composition ($y_{k+1,i+1}$) and that of the liquid ($x_{k+1,i}$) that descends from the next upper stage is:

$$y_{k+1,i+1} = \frac{L_{k+1,i} \cdot x_{k+1,i}}{V_{k+1,i+1}} + \frac{D \cdot x_D - \sum_{s=0}^k M_{GFs} \cdot z_{GFs}}{V_{k+1,i+1}} \quad (S.4)$$

This is the expression for the *operative line* corresponding to sector $k+1$ (OL_{k+1}) in the y/x diagram in the method of McCabe-Thiele. The slope of this OL is the molar liquid flow rate divided by the molar vapor flow rate in the corresponding sector, that applying the condition of constant overflow (CMO) are constant at each section of the column and results:

$$m_{k+1} = \frac{L_{k+1,i}}{V_{k+1,i+1}} = \frac{L_{k+1,i}}{L_{k+1,i} + D - \sum_{s=0}^k M_{GFs}} = \frac{L_D + \sum_{s=0}^k L_{GFs}}{L_D + \sum_{s=0}^k L_{GFs} + D - \sum_{s=1}^k M_{GFs}} \quad (S.5)$$

And the ordinate at the origin is given by:

$$b_{k+1} = \frac{D \cdot x_D - \sum_{s=0}^k M_{GFs} \cdot z_{GFs}}{V_{k+1,i+1}} = \frac{D \cdot x_D - \sum_{s=0}^k M_{GFs} \cdot z_{GFs}}{L_D + \sum_{s=0}^k L_{GFs} + D - \sum_{s=0}^k M_{GFs}} \quad (\text{S.6})$$

Obviously, both the slope and the ordinate at the origin are constant for a given sector and equation (S.4) represents a straight line in the y/x diagram.

Additionally, it can be obtained the intersection point between the OL_{k+1} and the diagonal line $y=x$:

$$y_{k+1,diagonal} = x_{k+1,diagonal} = \frac{D \cdot x_D - \sum_{s=0}^k M_{GFs} \cdot z_{GFs}}{D - \sum_{s=0}^k M_{GFs}} \quad (4) \text{ ó } (\text{S.7})$$

Regarding eqs. (S.5-S.7), we can deduce that the existence of a heat side stream affects to the slope and ordinate at the origin of the corresponding operative line (by the corresponding $L_{GFs} = -E_{GFs}/\lambda_{GFs}$ from Table 1), but it does not affect to the interception point with the diagonal.

5. Intersection between the OLs corresponding to two consecutive sectors (FP point)

The balances in the feed zone (Figures 3-5) provide the relationship between the vapor and liquid streams corresponding to two consecutive sectors, according to the nomenclature presented; it is evident that for a generalized feed:

$$L_{k+1,0} = L_{k,NTk} + L_{GFk} \quad (\text{S.8})$$

$$V_{k,0} = V_{k+1,1} + V_{GFk} \quad (\text{S.9})$$

We use the subscript 0 for the streams entering the last or first stages of a sector, and NTk for those leaving the last tray of a sector. Applying equation (S.4) to sectors k and k+1, and equations (S.8)-(S.9) gives:

$$\text{OL}_k: y_{k,0} = \frac{L_{k,NTk} \cdot x_{k,NTk}}{V_{k,0}} + \frac{D \cdot x_D - \sum_{s=0}^{k-1} M_{GFs} \cdot z_{GFs}}{V_{k,0}} \quad (\text{S.10})$$

$$\begin{aligned} \text{OL}_{k+1}: y_{k+1,1} &= \frac{L_{k+1,0} \cdot x_{k+1,0}}{V_{k+1,1}} + \frac{D \cdot x_D - \sum_{s=0}^{k-1} M_{GFs} \cdot z_{GFs} - M_{GFk} \cdot z_{GFk}}{V_{k+1,1}} = \\ &= \frac{(L_{k,NTk} + L_{GFk}) \cdot x_{k+1,0}}{V_{k,0} - V_{GFk}} + \frac{D \cdot x_D - \sum_{s=0}^k M_{GFs} \cdot z_{GFs}}{V_{k,0} - V_{GFk}} \end{aligned} \quad (\text{S.11})$$

In the case of a mass stream, solving the above system of equations provides the coordinates of the intersection point between these two operative lines (point FP in all the McCabe-Thiele diagrams shown in this paper). Moreover, it can be demonstrated, according to the definitions of L_{GFk} and V_{GFk} in eqs. (1, 2), that this intersection point is located over a characteristic so-called q-line or feed line [2, 4, 6-11] of equation:

$$\text{Ec. (S.10)-Ec. (S.11): } y \cdot V_{GFk} = -L_{GFk} \cdot x + M_{GFk} \cdot z_{GFk} \quad \therefore$$

$$\text{FL}_k: y = \frac{-L_{GFk}}{V_{GFk}} \cdot x + \frac{M_{GFk}}{V_{GFk}} \cdot z_{GFk} \quad \therefore y = \frac{-q_{GFk}}{(1-q_{GFk})} \cdot x + \frac{z_{GFk}}{(1-q_{GFk})} \quad (\text{S.12})$$

This equation represents a straight line in the y/x diagram that intercepts the diagonal at $y = x = z_{GFk}$, pass at the point (x_{GFk}, y_{GFk}) and that defines the loci of all possible points of intersection of the two operative lines in the above and below sections of the column.

The coordinates of the FP intersection point would be:

$$x_{FP(\text{mass feed stream})} = \frac{V_{k,0} \cdot M_{GFk} \cdot z_{GFk} - (D \cdot x_D - \sum_{s=0}^{k-1} M_{GFs} \cdot z_{GFs}) \cdot V_{GFk}}{V_{k,0} \cdot L_{GFk} + V_{GFk} \cdot L_{k,NTk}} \quad (\text{S.13a})$$

$$y_{FP(\text{mass feed stream})} = \frac{M_{GFk} \cdot z_{GFk} - (D \cdot x_D - \sum_{s=0}^{k-1} M_{GFs} \cdot z_{GFs}) \cdot \frac{V_{GFk}}{V_{k,0}}}{V_{k,0} \cdot \frac{L_{GFk}}{L_{k,NTk}} + V_{GFk}} + \frac{D \cdot x_D - \sum_{s=0}^{k-1} M_{GFs} \cdot z_{GFs}}{V_{k,0}} \quad (\text{S13b})$$

Obviously, equations (S.10-S.11) include all the cases considered in the referenced text books and some others considered herein. In the case of heat addition or removal a similar procedure with eqs. (S.10) and (S.11), where $V_{GFk} = E_{GFk}/\lambda_{GFk}$ and $L_{GFk} = -E_{GFk}/\lambda_{GFk}$ (eq. 1-2), yields:

$$y_{FP(\text{heat feed stream})} = x_{FP(\text{heat feed stream})} \quad (\text{S.14})$$

In other words, in the case of heat side streams, the operative lines of the two consecutive sectors intercept each other on the diagonal (eq. S.7).

6. Changeover operating line of a generalized feed side stream GF_k

a. Single feed (F) operative line

As it is very well know, the staircase construction of the McCabe-Thiele method alternates graphically the use of equilibrium and mass balances. Nevertheless, consecutive sectors must be connected in the column and it must be specified where to use each one of the corresponding OL and how to calculate the vapor stream leaving the first stage of each new sector when that of the liquid leaving the last stage of the upper sector is known, in order to obtain the minimum number of stages for the specified separation.

As stated above, the analysis of the change of sector in most references of the McCabe-Thiele method is limited to the location of the operative lines intersection point that we have named as FP, to obtain the least number of trays. Nevertheless, such analysis provides acceptable approximation of the number of trays, though the location of the streams involved in such zone remains a certain degree of ambiguity. This treatment does not allow a clear understanding of the different processes that may be involved whenever a generalized feed is introduced into a distillation column.

Before dealing with the general case, the differences of the classical and strict approach in the case of a single feed stream are shown in Figures 6a-b (corresponding to the schemes presented in Figure 1a-b), with a simplified nomenclature. With the classical approach, the feed is considered to be introduced to the column in bulk to a feeding stage (stage number 2 in Figure 1a) where it mixes with the vapor of the tray below and with the liquid of the tray above, and then the streams leaving this stage $V_2=V_2'$ and $L_2=L_1'$ are considered to be in equilibrium [23], i.e. when the step by step construction arrives to the composition $y_2 = y_2'$ by using UOL, the liquid composition x_2 is obtained directly from the equilibrium curve. The composition of the next vapor y_3 is located in the OL of the following sector, LOL (Figure 6a).

In an alternative approach, what is supposed to occur is that when a feed stream is introduced between two plates in the distillation column (1 and 2 in Figure 1b), it flashes adiabatically. The vapor fraction V_F will join the vapor coming from the stage below V_2 , whereas the feed liquid fraction L_F will join the liquid coming from the plate immediately above L_1 providing two streams (V_2' and L_1') that are not in equilibrium: $V_2' = V_2 + V_F = V_2 + F - L_F$ and $L_1' = L_1 + L_F$ (Figure 1b) [2, 6, 23], since they are the sum of two different

streams that are in equilibrium. In this case, all the streams involved in the change of sector zone can be unambiguously located in the McCabe-Thiele diagram.

Obviously in this case, the compositions of the stream L_1 and V_2 cannot be related applying directly any of the operative lines of the sector above or below the feed stream. Thus, the following expression can be obtained for the feed operating line (represented by FOL in the y/x diagram of Figure 6b) as the difference between the vapor stream ascending (V_2) from the first stage of the sector below the feed and the liquid stream (L_1) descending from the last stage of the sector above the feed [23]:

$$OL_2 : y_2 = \frac{L'_1 \cdot x'_1}{V_2} + \frac{D \cdot x_D - F \cdot z_F}{V_2} = \frac{L_1 \cdot x_1 + L_F \cdot x_F}{V'_2 - V_F} + \frac{D \cdot x_D - F \cdot z_F}{V'_2 - V_F}$$

$$FOL : y_2 = \frac{L_1}{L_1 + D - F + L_F} \cdot x_1 + \frac{D \cdot x_D - F \cdot z_F + L_F \cdot x_F}{L_1 + D - F + L_F} \quad (5)$$

Comparison of y/x diagrams in Figures 6a-b, where all streams involved are located, evidences the limitations of the classical method in what respects the change of sector stage. Both approaches would give the same results for the case where x_F coincided with x_1 or y_F coincided with y_2 , but the FOL is necessary when there are differences between x_F and x_1 and between y_F and y_2 . The use of the FOL guarantees an improved and reality coherent construction of the column with the hypothesis considered. If FP is used to define the change of sector and the feed is introduced between IP_1 and IP_2 , the calculated streams predict a poorer mixture separation compared to what would really happen in the column, if the alternative approach is considered.

Nevertheless, differences between the two approaches are not so considerable and they depend on the thermal condition of the feed stream, the relative volatility of the system

and other parameters, such as the reflux ratio, and also the position of the feed. For saturated liquid and vapor feeds both approaches would have given the same results, as we will see in section 4. For the rest of cases there are two limiting situations (minimum and maximum L_D/D reflux ratios) where the results obtained are also the same. For intermediate situations between minimum and maximum L_D/D reflux ratios calculated differences (always lower than one tray but that can be relevant if we consider the compositions of the following trays) depend on the column characteristics and the system equilibrium. As we can see in Figures 7a-c, the stage number tends to rise quickly in the first case (a) but for intermediate situations (b) we can see that differences are higher (especially if the last liquid descending from the previous sector lies nearly in the middle of the FOL). For the limiting case (c) both approaches tend to the same result.

b. Generalized feed operative line (GFOL)

When dealing with generalized feeds (Table1: feed, product or heat stream), applying eq. (3) to the stage 1 of the k+1 sector and considering that:

1. the streams entering the first tray of a sector come from an hypothetical tray 0 above and have, consequently the 0 tray index,
2. the sector k has a NT_k total number of trays,
3. the liquid flow rate in that sector is given by:

$$L_{k+1,0} = L_{k,NTk} + L_{GFk} \quad (6a)$$

4. the more volatile component molar flow rate is given by:

$$L_{k+1,0} \cdot x_{k+1,0} = L_{k,NTk} \cdot x_{k,NTk} + L_{GFk} \cdot x_{GFk} \quad (6b)$$

the expression for the generalized OL of the feed stream k, that we will call GFOL_k for the general case, and that relates $x_{k,NTK}$ (the composition of the liquid leaving the last tray NTK of sector k) with $y_{k+1,1}$ (the composition of the vapor leaving the first tray of sector k+1), can be written as follows:

$$y_{k+1,1} = \frac{L_{k+1,0} \cdot x_{k+1,0}}{V_{k+1,1}} + \frac{D \cdot x_D - \sum_{s=0}^k M_{GFs} \cdot z_{GFs}}{V_{k+1,1}} = \frac{L_{k+1,0} \cdot x_{k+1,0}}{L_{k+1,0} + D - \sum_{s=0}^k M_{GFs}} + \frac{D \cdot x_D - \sum_{s=0}^k M_{GFs} \cdot z_{GFs}}{L_{k+1,0} + D - \sum_{s=0}^k M_{GFs}} \quad \therefore$$

$$y_{k+1,1} = \frac{L_{k,NTk}}{L_{k,NTk} + L_{GFk} + D - \sum_{s=0}^k M_{GFs}} \cdot x_{k,NTk} + \frac{D \cdot x_D - \sum_{s=0}^k M_{GFs} \cdot z_{GFs} + L_{GFk} \cdot x_{GFk}}{L_{k,NTk} + L_{GFk} + D - \sum_{s=0}^k M_{GFs}} \quad \therefore$$

$$\text{GFOL}_k: y_{k+1,1} = \frac{L_D + \sum_{s=0}^{k-1} L_{GFs}}{L_D + \sum_{s=0}^k L_{GFs} + D - \sum_{s=0}^k M_{GFs}} \cdot x_{k,NTk} + \frac{D \cdot x_D - \sum_{s=0}^k M_{GFs} \cdot z_{GFs} + L_{GFk} \cdot x_{GFk}}{L_D + \sum_{s=0}^k L_{GFs} + D - \sum_{s=0}^k M_{GFs}} \quad (7)$$

The characteristic points IP_k and IP_{k+1} , where the GFOL_k (eq. 7) intercepts the operative lines of the consecutive sectors that the generalized feed GF_k separates, OL_k and OL_{k+1}, can be easily calculated:

$$\text{Ec.(6)-Ec. (3)}_{\text{sector } k}: y_{IP_k} = y_{GFk}$$

$$\text{Ec.(6)-Ec. (3)}_{\text{sector } k+1}: x_{IP_{k+1}} = x_{GFk}$$

These two intercepts allow every GFOL_k to be easily drawn in the McCabe-Thiele diagram, once the OLs that they connect and the x_{GFk} , y_{GFk} coordinates (Table 1) are known.

The x coordinate of the point IP_k , must be considered as the composition at the optimal change point of sector k , e.i. this $x_{opt,k}$ indicates the optimal location of the generalized side stream k .

$$x_{opt,k} = x_{IPk} = \frac{y_{GFk} \cdot (L_{k,NTk} + D - \sum_{s=0}^{k-1} MF_s)}{L_{k,NTk}} - \frac{D \cdot x_D - \sum_{s=0}^{k-1} MF_s \cdot z_{GFs}}{L_{k,NTk}} \quad (8)$$

The $GFO L_k$ must be used only once in the graphical McCabe-Thiele staircase construction, with the meaning that the feed has entered the column and the new liquid and vapor streams must be correspondingly updated. To obtain the minimum number of stages such a calculation (i.e., the use of $GFO L_k$ in the step by step calculations) must be done the first time a liquid stream composition in the k sector ($x_{k,NTk}$) is lower or equal than $x_{opt,k}$.

In the following section we will analyze in detail the different possibilities of generalized feeds GF_k : mass feeds, considering their thermal conditions, the removal of a liquid or vapor product as well as the heat addition to a liquid stream or heat removal from a vapor stream in a rectifying sector, i.e.: a sector above the main mass feed.

7. Classical calculation of the number of trays of a sector in the McCabe-Thiele Method (staircase construction)

In the y/x -composition diagram, the algorithm for the calculation of the number of trays of the column in sector $k+1$, proceeds according the following scheme:

1. First, a liquid of a certain composition ($x_{k+1,i}$) descending from the stage i of sector $k+1$ is located on the OL_{k+1} . This composition coincides with x_D (composition of the

distillate and reflux for a total condenser) if the first stage of the first sector is considered ($k=0$).

2. The composition of the vapor ($y_{k+1,i+1}$) leaving the next stage is obtained by using the OL_{k+1} (eqs. S.4-S.6) connecting stages i and $i+1$ in sector $k+1$. This vapor is represented by the horizontal line constructed from $x_{k+1,i}$, located on the OL_{k+1} .
3. The liquid $x_{k+1,i+1}$, leaving the same stage $i+1$ as the vapor of composition $y_{k+1,i+1}$, is given by the equilibrium curve. Through the point $(x_{k+1,i+1}, y_{k+1,i+1})$ a vertical line is drawn to obtain $(x_{k+1,i+1}, y_{k+1,i+2})$ at the intersection with the OL_{k+1} .

This algorithm describes the construction of stages in a sector.

Nevertheless, as it is described previously, consecutive sectors must be connected in the column and it must be specified where to use each one of the corresponding OL and how to calculate the vapor stream leaving the first stage of each new sector when that of the liquid leaving the last stage of the upper sector is known, in order to obtain the minimum number of stages for the specified separation.

5. Conclusions

The McCabe-Thiele method is an approximate graphical tray by tray method for the design of distillation columns that may provide a clear picture of what is happening in a distillation column.

Generalized equations for the corresponding OL for the different sectors in a column as well as those for the changes of sectors are presented.

Acknowledgments: We gratefully acknowledge financial support from the Vice-Presidency of Research (University of Alicante, Spain).

Supplementary Material

Marcilla, Serrano and Reyes-Labarta (Analysys of the coneccting zone of the McCabe-Thiele method, covering generalized side streams: multiple feeds, products and heat. AIChE J. 2012, in review) presents a complete analysis of what may happen when changing sector in the column due to generalized mass or heat feed side streams. All the streams involved in the stages corresponding to these changes of sectors, as well as the operating and changeover lines are unambiguously located in the McCabe-Thiele diagram, thus facilitating the comprehension of the method. The analysis of several examples reveals that significant differences in the composition of the trays below the generalized feeds may be obtained when comparing the traditional McCabe Thiele method.

Notation

D	Distillate stream (kmole/h)
E_{GFk}	Heat addition or extraction after sector k (kcal/h)
FL_k	Feed line of feed stream k
	$y = \frac{-L_{GFk}}{V_{GFk}} \cdot x + \frac{M_{GFk}}{V_{GFk}} \cdot z_{GFk} = \frac{-q_{GFk}}{(1-q_{GFk})} \cdot x + \frac{z_{GFk}}{(1-q_{GFk})}$
FOL	Feed operating line
FP	Feed point
GF_k	Generalized feed that separates sector k and k+1 (kmole/h)
$GFOL_k$	Generalized feed operating line
H_F	Specific enthalpy of the feed mixture stream (kcal/kmole)
H_F	Dew-point vapor enthalpy (kcal/kmole)

h_F	Bubble point liquid enthalpy (kcal/kmole)
IP_k	Intersection point between OL_k and $GFOl_k$
IP_{k+1}	Intersection point between OL_{k+1} and $GFOl_k$
L_D	Liquid reflux to the column (kmole/h)
L_F, L_{GFk}	Liquid portion of the feed stream or generalized feed stream k
$L_{k,i}$	Liquid from stage i of sector k (kmole/h)
LOL	Lower section operating line
λ_F, λ_{GFk}	Enthalpy of vaporization or latent heat (kcal/kmole) of the feed stream
M_{GFk}	Mass feed or product stream that separates sector k and k+1 (kmole/h)
OL_{k+1}	Operating line of sector k+1:
q_F, q_{GFk}	Thermal condition of the feed stream or generalized feed stream k
Q_D	Heat extracted from the condenser (kcal/h)
Q_R	Heat added to the reboiler (kcal/h)
R	Residue stream (kmole/h)
UOL	Upper section operating line
V_F, V_{GFk}	Vapor portion of the feed stream or generalized feed stream k
$V_{k,i}$	Vapor from stage i of sector k (kmole/h)
x_D	Composition of the distillate and the liquid reflux stream (mole fraction)
x_{FP}	Composition of the intersection point FP (mole fraction)
x_F, x_{GFk}	Liquid feed composition of the volatile component (mole fraction)
x_{IPk}	x coordinate of the point IP_k ($=x_{opt,k}$)
x_{IPk+1}	x coordinate of the point IP_{k+1} ($=x_{GFk}$)
$x_{k,diagonal}$	x coordinate of the intersection point between OL_k and the diagonal, in the McCabe-Thiele diagram
$x_{k,i}$	Composition of liquid falling from stage i of sector k (kmole/h)
$x_{opt,k}$	x coordinate of the optimal location of the generalized stream k (when the staircase calculation is started from the top of the column)
x_R	Composition of the residue (mole fraction)
y_F, y_{GFk}	Vapor feed composition of the volatile component (mole fraction)

$y_{k,diagonal}$	y coordinate of the intersection point between OL_k and the diagonal, in the McCabe-Thiele diagram
$y_{k,i}$	Composition of vapor ascending from stage i of sector k (kmole/h)
y_{IPk}	y coordinate of the point $IP_k (=y_{GFk})$
z_F, z_{GFk}	Generalized feed composition of the volatile component (mole fraction)
<i>Subscripts</i>	
i	Stage
k	Sector
N_{Tk}	Number of plates of the sector k

Literature cited

1. McCabe WL, Thiele WE. Graphical design of fractional columns. Ind. Eng. Chem. 1925;17:605-611.
2. Seader JD, Henley EJ, Roper DK. Separations Process Principle. Chemical and Biochemical Operations (3th edition). New York:John Willey & Sons,Inc. 2011.
3. Petlyuk FB. Distillation Theory and its Application to Optimal Design of Separations Units. Cambridge Series in Chemical Engineering. 2004.
4. Stichmair JG, Fair JR. Distillation: Principles and Practice. New York:Willey-VCH, 1998.
5. Biegler LT, Grossmann IE, Westerberg AW. Systematic Methods of Chemical Process Design. New Jersey:Prentice Hall, 1997.
6. McCabe WL, Smith JC, Harriot P. Unit Operations of Chemical Engineering (5th edition). New York:McGraw-Hill. 1993.
7. Kister HZ. Distillation Design. New York:McGraw-Hill. 1992.
8. King CJ. Chemical Engineering Series. Separation Processes. New York:McGraw-Hill. 1980.

9. Treybal RE. Mass Transfer Operations, Chemical Engineering Series (3th edition). New York:McGraw Hill. 1981.
10. Henley EJ, Seader JD. Equilibrium-Stage Separation Operatins in Chemical Engineering. New York:John Willey & Sons. 1988.
11. Doherty MF, Malone MF. Conceptual design of distillation systems. New York:McGraw-Hill. 2001.
12. Kister HZ. Graphically find theoretical trays and minimum reflux for complex binary distillation. Chemical Engineering. 1985, January 21, 97-104.
13. Khoury FM. Predicting the performance of multistage separation processes. Florida:Boca Raton CRC Press. 2000.
14. Benitez J. Principles and modern applications of mass transfer operations. New York:Wiley-Interscience. 2002.
15. Van Winkle M. Distillation. Chemical Engineering Series. New York:McGraw-Hill. 1967.
16. Noble RD, Terry PA. Principles of Chemical Separations with Environmental Applications. Cambridge (UK):Cambridge University Press. 2004.
17. Rousseau RW. Handbook of Separation Process Technology. New York:Wiley-Interscience. 1987.
18. Thompson RE. McCabe-Thiele Methods-Simple Columns. AIChEMI. Modular Instruction. Series B: Stagewise and mass transfer operations. Binary Distillation. AIChE. Module B1.6. 1980, 27.
19. Thompson RE. McCabe-Thiele Methods-Advanced Topics; AIChEMI. Modular Instruction. Series B: Stagewise and mass transfer operations. Binary Distillation. AIChE. Module B1.7. 1980, 35.
20. [online] <http://demonstrations.wolfram.com/McCabeThieleGraphicalMethod/>
21. [online] <http://www.mathworks.com/matlabcentral/fileexchange/4472>

22. [online] http://www.prosim.net/en/resources/examples/helpfiles_en_sth.html
23. Ledanois JM, Olivera-Fuentes C. Modified Ponchon-Savarit and McCabe-Thiele methods for distillation of Two-Phase Feeds. *Ind. Eng. Chem. Process Des. Dev.* 1984, 23, 1-6.
24. Reyes-Labarta JA, Caballero JA, Marcilla A. novel hybrid simulation-optimization approach for the optimal design of multicomponent distillation columns. *Computer Aided Chemical Engineering.* 2012, 30: 1257:1261.
25. Reyes-Labarta, J.A.; Grossmann, I.E. Disjunctive optimisation Design Models for Complex Liquid-Liquid Multistage Extractors. *AIChE J.* 2001; 47(10): 2243-2252.
26. Reyes-Labarta, J.A.; Grossmann I.E. Optimal Synthesis of Liquid-Liquid Multistage Extractors using Mixed Integer Nonlinear Programming Techniques. *Computer Aided Chemical Engineering* **2001**; 9: 487-492 (European Symposium of Computer Aided Process Engineering-11).
27. Ravi R. Transformations for a generalized McCabe-Thiele method: A retrospective and a new perspective. *International Communications in Heat and Mass Transfer.* 2008, 35: 860-866.
28. Wankat PC. *Equilibrium Staged Operations.* New Jersey:Prentice Hall. 1988.
29. Lee JW, Hauan S, Lien KM, Westerberg AW. A graphical method for designing reactive distillation columns: I. the Ponchon-Savarit method, *Proc. of the Royal Society A: Mathematical, Physical & Engineering Sciences.* 2000, 456, 1953-1964.
30. Marcilla A, Gómez A, Reyes JA, Olaya MM. New method for quaternary systems liquid-liquid extraction tray to tray design. *Ind. Eng. Chem. Res.* 1999, 38(8): 3083-3095.
31. Marcilla A, Gómez A, Reyes J. New method for designing distillation columns of multicomponent mixtures. *Latin American Applied Research International Journal on Chemical Engineering.* 1997, 27, 51-60.

32. Reyes-Labarta, J.A. Resume of the Extension of the Ponchon and Savarit Method for Designing Ternary Rectification Columns (RUA 1998). <http://hdl.handle.net/10045/14600>.
33. Marcilla, A.; Serrano, M.D.; Reyes-Labarta, J.A. Analysis of the Zone Connecting Consecutive Sectors in Distillation Columns by the Ponchon-Savarit Method. 12th Mediterranean Congress of Chemical Engineering (EXPOQUIMIA'11). 2011. <http://hdl.handle.net/10045/19864>.
34. Yaws CL, Li KY, Fang CS. How to find the minimum reflux for binary systems in multiple-feed columns. Chemical Engineering. 1981, May 18, 153-156.
35. Reyes JA, Gómez A, Marcilla A. Graphical concepts to orient the Minimum Reflux Ratio Calculation on Ternary Mixtures Distillation. Ind. Eng. Chem. Res. 2000, 39, 3912-3919.
36. Johnson JE, Morgan DJ. Graphical techniques for process engineering. Chemical Engineering. 1985, July 8, 72-83.
37. Nakaiwa M, Huang MK, Endo A, Ohmori T, Akiya T, Takamatsu T. Internally heat integrated distillation columns: A review. Chem. Eng. Res. Des. 2003;81:162-177.
38. Shenvi AA, Herron DM, Agrawal R. Energy efficiency limitations of the conventional heat integrated distillation column (HIDiC) configuration for binary distillation. Ind. Eng. Chem. Res. 2011;50:119-130.
39. Huang K, Matsuda K, Iwakabe K, Takamatsu T, Nakaiwa M. Graphical Synthesis of an Internally Heat-Integrated Distillation Column. J. Chem. Eng. Jpn. 2006, 39, 703.
40. Ho TJ, Huang CT, Lee LS, Chen CT. Extended Ponchon-Savarit method for graphically analyzing and designing internally heat-integrated distillation columns. Ind. Eng. Chem. Res. 2010;49:350-358.