









## Open Archive Toulouse Archive Ouverte (OATAO)

OATAO is an open access repository that collects the work of Toulouse researchers and makes it freely available over the web where possible

This is an author's version published in: <http://oatao.univ-toulouse.fr/20295>

**Official URL:** <https://doi.org/10.1007/s10811-013-0212-3>

### To cite this version:

Safi, Carl  and Camy, Séverine  and Frances, Christine  and Varela, Mateo Montero  and Badia, Enrique  and Pontalier, Pierre-Yves  and Vaca-Garcia, Carlos  *Extraction of lipids and pigments of *Chlorella vulgaris* by supercritical carbon dioxide: influence of bead milling on extraction performance.* (2014) *Journal of Applied Psychology*, 26 (4). 1711-1718. ISSN 0921-8971

Any correspondence concerning this service should be sent to the repository administrator: [tech-oatao@listes-diff.inp-toulouse.fr](mailto:tech-oatao@listes-diff.inp-toulouse.fr)

# Extraction of lipids and pigments of *Chlorella vulgaris* by supercritical carbon dioxide: influence of bead milling on extraction performance

Carl Safi · Séverine Camy · Christine Frances ·  
Mateo Montero Varela · Enrique Calvo Badia ·  
Pierre-Yves Pontalier · Carlos Vaca-Garcia

**Abstract** The influence of bead milling on the extraction of lipids and pigments by supercritical carbon dioxide was investigated in this study. Different operating parameters for the 3-h process were first tested on raw *Chlorella vulgaris*; 600 bar was the optimum pressure at 60 °C with a carbon dioxide flow rate of 30 g min<sup>-1</sup>. Under these operating conditions, 10 % of total lipid containing chlorophyll and carotenoids with 1.61 and 1.72 mg g<sup>-1</sup> dry weight of microalga, respectively, has been recovered. Microscopic observation was used to assess a cell wall breakage through bead milling, which produced positive results in terms of increasing the yield of biomolecules of interest. Thus, under the same operating conditions, the yield of total lipid extract, chlorophyll and carotenoids increased significantly. Moreover, the addition of a polar co-solvent to a raw microalga had a considerable effect on the final extract. Overall, the addition of 5 % w v<sup>-1</sup> ethanol to a raw microalga increased the total extract yield by 27 %, and bead milling increased the total extract

yield by 16 %. Chlorophyll and carotenoids were also significantly affected by the addition of ethanol, with an 81 and 65 % increase with a raw microalga and a 61 and 52 % increase using bead milling, respectively.

**Keywords** Lipids · Chlorophyll · Carotenoids · Bead milling · Supercritical carbon dioxide · Co-solvent

## Introduction

Microalgae represent considerable feedstock diversity in terms of the isolation of natural biomolecules of significant commercial interest (Spolaore et al. 2006) for the pharmaceutical (Kitada et al. 2009), cosmetics (Raposo et al. 2013), animal nutrition and aquaculture (Becker 2007) and bioenergy (Chisti 2007; Demirbas 2011; Gouveia 2011; Li et al. 2008) industries. Thus, they reflect a biomass composed of multiple high-added value components. Over the last decade, many different industries have become increasingly interested in natural products that are beneficial for human health and environmentally friendly, and microalgae are potential candidates that could contribute to satisfy this growing demand.

*Chlorella vulgaris*, a green microscopic microalga with a rigid cell wall (Nemkova and Kalina 2000), is an important species with an interesting composition that has attracted the attention of scientists over the last century. It is rich in chlorophyll and proteins, and if it is grown under specific conditions, it can accumulate large amounts of lipids (Mallick et al. 2012; Mizuno et al. 2012; Widjaja et al. 2009) and valuable carotenoids such as astaxanthin,  $\beta$ -carotene and canthaxanthin (Mendes et al. 1995). Like all microalgae, there are two types of lipids in *C. vulgaris*, neutral and polar lipids. Phospholipids and glycolipids are polar lipids that are present on the cell wall as well as on the membranes of internal

---

C. Safi (✉) · M. M. Varela · E. C. Badia · P.-Y. Pontalier ·  
C. Vaca-Garcia

Laboratoire de Chimie Agro-Industrielle (LCA), INP-ENSIACET,  
Université de Toulouse, 31030 Toulouse, France  
e-mail: carl.safi@ensiacet.fr

C. Safi · M. M. Varela · E. C. Badia · P.-Y. Pontalier · C. Vaca-Garcia  
UMR 1010 CAI, INRA, 31030 Toulouse, France

S. Camy · C. Frances  
Laboratoire de Génie Chimique (LGC), INP, UPS, Université de  
Toulouse, B.P. 84234, 4, Allée Emile Monso, 31432 Cedex 4, France

S. Camy · C. Frances  
LGC, CNRS, 31432 Cedex 4, France

C. Vaca-Garcia  
Center of Excellence for Advanced Materials Research, King  
Abdulaziz University, Jeddah, Saudi Arabia

organelles such as the chloroplasts and the mitochondria (Solomon et al. 1999). Conversely, neutral lipids such as triacylglycerol are in the form of lipid droplets in the chloroplast matrix and can also be present in the cytoplasm (Hu et al. 2008) if the microalga is grown under nitrogen limitation and other harsh conditions. Chlorophyll and primary carotenoids are concentrated in thylakoids, but some carotenoids such as  $\beta$ -carotene exist inside lipid droplets. These biomolecules are of great nutritional interest because they are known to have antioxidant activities, can reduce the risk of cardiovascular diseases, and have antitumor activities (Konishi et al. 1985) and other health benefits (Lordan et al. 2011).

Demand from the food industry for additives natural in origin, and with characteristics contributing to increase health benefits, is growing every year. In addition, legislation has imposed further quality enhancement on products destined for human consumption, while systematically restricting the use of conventional methods with potentially harmful consequences on human health. Thus, obtaining a product free from contaminants and solvents is extremely important to maintain the added value of the final product. In this framework, supercritical CO<sub>2</sub> extraction is a processing technique that respects the requirements imposed by the legislation as well as the environment and improves the quality of the final product by providing an additional argument for commercializing a healthy product without the expected side effects. Hence, several studies have reported results of lipid fraction extraction using the supercritical CO<sub>2</sub> process, by focusing on different aspects and the ultimate parameters that would maximize yield (Mendes et al. 2003).

The literature covers a range of studies that have used supercritical carbon dioxide, in order to determine the best parameters for extracting valuable biomolecules such as lipids and pigments from microalgae. Among the latter should be noted are two studies that aimed to show the beneficial effect of cell crushing before supercritical extraction (Gouveia 2011; Mendes et al. 1995; Crampon et al. 2013) and succeeded in at least doubling the extraction yield. The article of Crampon et al. (2011) presents an overview of compounds of interest obtained from supercritical CO<sub>2</sub> extraction of microalgae. The present study proposes the use of ethanol as a co-solvent in supercritical extraction, to avoid additional energy input in terms of a supplementary unit operation of cell disruption.

## Materials and methods

Sueoka culture medium was used for growing *Chlorella vulgaris* (strain SAG 211-19) in batch mode in an indoor tubular air-lift photobioreactor (PBR, 10 L) at 25 °C, inoculated from a prior culture in a flat panel air-lift PBR (1 L). Culture homogenization was achieved by sterile air injection at the bottom of the PBR. The pH and temperature were recorded

using a pH/temperature probe (Mettler Toledo SG 3253 sensor) monitored using LabVIEW acquisition software. The pH was maintained at 7.5 with CO<sub>2</sub> bubbling. The microalgae were harvested by centrifugation during the exponential growth phase and supplied as frozen paste from Alpha Biotech (Asserac, France). The harvested biomass contained 20.0 % dry matter; total lipids represented 15.2 % of dry matter (obtained by Bligh and Dyer method), chlorophyll 1.8 % of dry matter (UV-Vis spectroscopic analysis) and carotenoids 1.3 % of dry matter (UV-Vis spectroscopic analysis).

### Mechanical cell disruption

Cells were treated in a stirred bead mill (LabStar, Netzsch). Disruption was conducted using 0.3–0.5 mm Y<sub>2</sub>O<sub>3</sub>-stabilized ZrO<sub>2</sub> grinding beads. Milling time for both trials was 1–60 min with a 1:13 solid water ratio (w v<sup>-1</sup>). The process was performed in batch mode. The initial cell suspension was placed in a pre-dispersion tank and stirred at 350 rpm in order to avoid cell sedimentation and ensure a good homogeneity of the solid concentration. During the experiments, the suspension was continuously pumped from the tank to the mill inlet using a peristaltic pump at a flow rate of about 30 L h<sup>-1</sup> and sent back again into the dispersion tank through a cartridge to keep the beads inside the chamber. Stirring speed of the cell suspension and the beads within the grinding chamber was 2,500 rpm. The bead mill contained an integrated cooling system to prevent overheating, and thus, after 1 h of milling, the temperature did not exceed 33 °C. At the end, the broken cells were recovered for further processing.

### Freeze-drying

The frozen paste of raw microalga and cells treated by bead milling was introduced directly into a Fisher Bioblock Scientific Alpha 2-4 LD Plus device (Illkirch, France). The pressure was reduced to 0.010 bar, the temperature further decreased to –80 °C, and freeze-drying was conducted under vacuum for 48 h to give a completely dry biomass. After freeze-drying, the mean diameter of particles, measured using a Mastersizer 2000 granulometer (Malvern Instruments Ltd.) was around 250  $\mu$ m. Freeze-dried aggregates were then slightly crushed with a laboratory knife grinder to give a final size of 200  $\mu$ m.

### Supercritical carbon dioxide extraction setup

The experimental setup used for supercritical extraction (Fig. 1) was a SFE100 from Separex Chimie fine (France). It was composed of a 25-mL tubular extractor (internal diameter 2 cm, height 8 cm) which could be operated up to 1,000 bar and 200 °C. One separator was connected to the extractor outlet, and the pressure in the extractor was adjusted by a backpressure regulator. At the beginning of the experiment,

**Fig. 1** Schematic representation of the supercritical carbon dioxide pilot experiment (*CG* cooling unit, *HG* heating unit, *Ex* extractor, *S* separator)

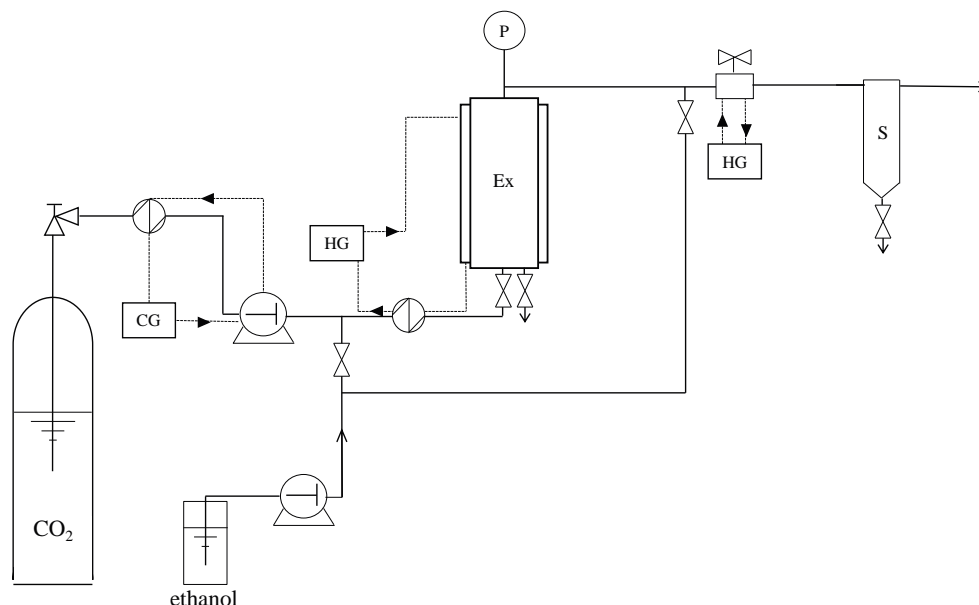

the extractor was filled with powdered freeze-dried microalgae (6 g), and CO<sub>2</sub> was introduced at the bottom. The sample was left for 20 min at the desired operating temperature and pressure, and CO<sub>2</sub> was then introduced at a constant flow rate (30 g min<sup>-1</sup>). Ethanol can be used as a co-solvent and mixed with CO<sub>2</sub> at the extractor inlet and can also be used as a washing co-solvent. In this case, it is mixed with the extract (CO<sub>2</sub> and solutes) at the extractor outlet. This procedure gives an efficient solute recovery in the separator, and extraction time was set at 180 min for all samples. The extracts were collected in the separator and then stored in the dark at 4 °C to prevent degradation of samples awaiting analyses. The extractor and the separator were cleaned after each run. Extraction yield is calculated after isolation of lipid extract using

$$Y(\%) = \frac{m \text{ extract (g)}}{m \text{ dry microalgae (g)}} \times 100.$$

As supercritical CO<sub>2</sub> is a nonpolar solvent, the extract is assumed to contain only neutral lipids and pigments, and in view of the very low amount of pigments, the global yield is thus assumed to be the neutral lipid yield. When ethanol is used as a co-solvent, the polarity of the mixture is increased, and therefore, polar lipids are presumed to be extracted at the same time, in which case, the global yield is assumed to be the total lipid yield.

#### Analysis of pigments

Aqueous extract (200 μL) were mixed with 1,300 μL acetone and then incubated in the dark for 1 h at 45 °C. The samples were then centrifuged at 10,000g for 10 min at 20 °C. The

organic phase containing the pigments was then recovered and analysed by UV–Vis spectroscopy and then quantified using the following equations (Ritchie 2006):

$$\begin{aligned} \text{Total chlorophyll } (\mu\text{g mL}^{-1}) &= 24.1209A_{632} + 11.2884A_{649} \\ &\quad + 3.7620A_{665} + 5.8338A_{696} \\ \text{Total carotenoids } (\mu\text{g mL}^{-1}) &= 4.744_{466} \end{aligned}$$

#### Confocal microscopy

Cells were observed using a SP2-AOBS confocal laser-scanning microscope from Leica Microsystems (Nanterre, France). Fluorochrome calcofluor white that binds to the cell wall was added to the samples. With an excitation wavelength of 488 nm, the cell walls appear light blue, and at 633 nm, the internal parts of the cells are red.

#### Results

The lipophilic fraction (lipids and pigments) of the green microalga *C. vulgaris* was extracted by supercritical CO<sub>2</sub>. For raw *C. vulgaris*, two different pressures (350 and 600 bar) were tested during 3 h at 60 °C, and the results are shown in Fig. 2 where it can be noticed that 600 bar was more effective in terms of the quantity of lipids and carotenoids extracted. However, the quantity of chlorophyll extracted was not significantly different for both pressures applied.

Bead milling was carried out for 1 h, and then, confocal microscopy was carried out in order to follow up with the state of cells after cell disruption. It can be seen in Fig. 3 that cells

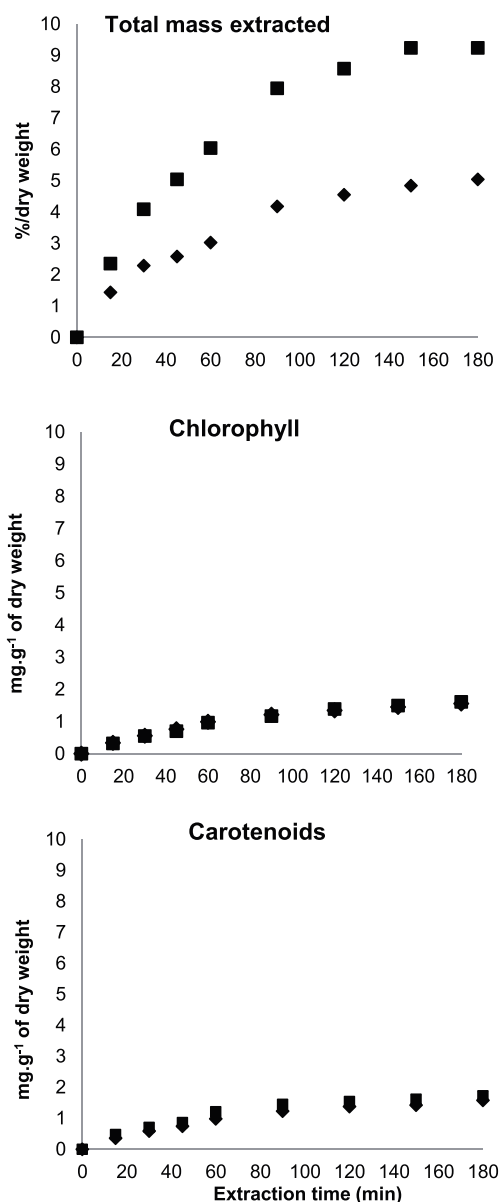

**Fig. 2** Influence of pressure on the extraction process of total lipids and pigments. *Diamond* indicates raw microalga (350 bar, 30 g min<sup>-1</sup> CO<sub>2</sub> flow rate, 60 °C), and *square* indicates raw microalga (600 bar, 30 g min<sup>-1</sup> CO<sub>2</sub> flow rate, 60 °C)

were broken after 1 h of bead milling. The same parameters chosen previously for raw *C. vulgaris* were used to extract the lipophilic part after bead milling. Therefore, aspects, such as the recovery yield, slightly increased for lipids and pigments compared to the results obtained on raw microalga without pretreatment (Fig. 4).

Figure 5 shows the results obtained after adding ethanol to supercritical CO<sub>2</sub> in order to increase the polarity of the solvent. Thus, on a dry weight basis, the recovery yield of lipids and pigments significantly increased and was the highest recovery compared to the treatments applied previously.

## Discussion

The present study focuses on using supercritical CO<sub>2</sub> on *C. vulgaris*, to assess the influence of operating parameters and pretreatment of the cell by bead milling on the recovery of lipids and pigments. Supercritical extraction was carried out on raw cells and cells treated by bead milling, and both were extracted using only CO<sub>2</sub> and CO<sub>2</sub> with ethanol as a co-solvent. To our knowledge, these three aspects have been tested separately on *C. vulgaris*, but not in a single study, and the main objective of this work was to analyse whether bead milling can be used to break down the cell wall efficiently before submitting *C. vulgaris* to supercritical carbon dioxide extraction.

Firstly, the operating conditions for supercritical extraction were determined. By changing its density, pressure and temperature define the extraction power of supercritical carbon dioxide. While an increase of pressure directly improves the solvent power by increasing CO<sub>2</sub> density, the effect of temperature is not equally predictable. Indeed, temperature is influencing the solvent density as a solute vapour pressure. Thus, the solubility of solute in CO<sub>2</sub> may be positively or negatively influenced by a temperature increase, depending on the pressure. In the present study, the pressure selected is high (more than 350 bar), and at the same time, the operating temperature set at 60 °C is expected to have a positive influence on the extraction yield (Mendes et al. 1995). The extraction kinetics of lipids and pigments (carotenoids and chlorophyll) obtained at 600 bar and 60 °C are shown in Fig. 2. The shape of the curves is typical of supercritical extraction processes, comprising a first linear part where extraction is limited by apparent solubility of solute(s) into scCO<sub>2</sub> (constant rate of extraction) and a second part where the rate of extraction is diminishing progressively, mostly limited by an internal mass transfer of the solute out of the cell. Considering the slope of the linear part of the curve (very restricted here), it can be assumed that the lipids are loosely linked to the structure of the cell. After 180 min of extraction, the recovery yield is 9 % w v<sup>-1</sup>, which means that, as expected, the total lipids (15.2 % w v<sup>-1</sup>) are not being recovered. Moreover, without specific pretreatment of the raw material, it is well known that, because of the cell structure (Kapaun and Reisser 1995), a part of the lipids remains inaccessible to the solvent. The shape of the curves corresponding to the extraction kinetics of pigments is very similar to that for lipid extraction. As expected from the literature, a part of lipophilic carotenoids are extracted, although the yield is quite low (0.17 % w v<sup>-1</sup> compared to 1.3 % w v<sup>-1</sup> obtained using Soxhlet extraction), and a very similar result is obtained for chlorophyll (0.18 % w v<sup>-1</sup> compared to 1.8 % w v<sup>-1</sup>). Although it is well known that the latter compound is not soluble in scCO<sub>2</sub>, its extraction from microalgae has already been reported at high pressure (Crampon et al. 2011). In addition, it can be observed that,

**Fig. 3** Confocal microscopic observations before bead milling (*upper pictures*) and after bead milling (*lower pictures*). The pictures on the left with a 488-nm excitation wavelength show the cell walls in *light blue*. The pictures on the right at 633 nm show the internal parts of the cells in *red*

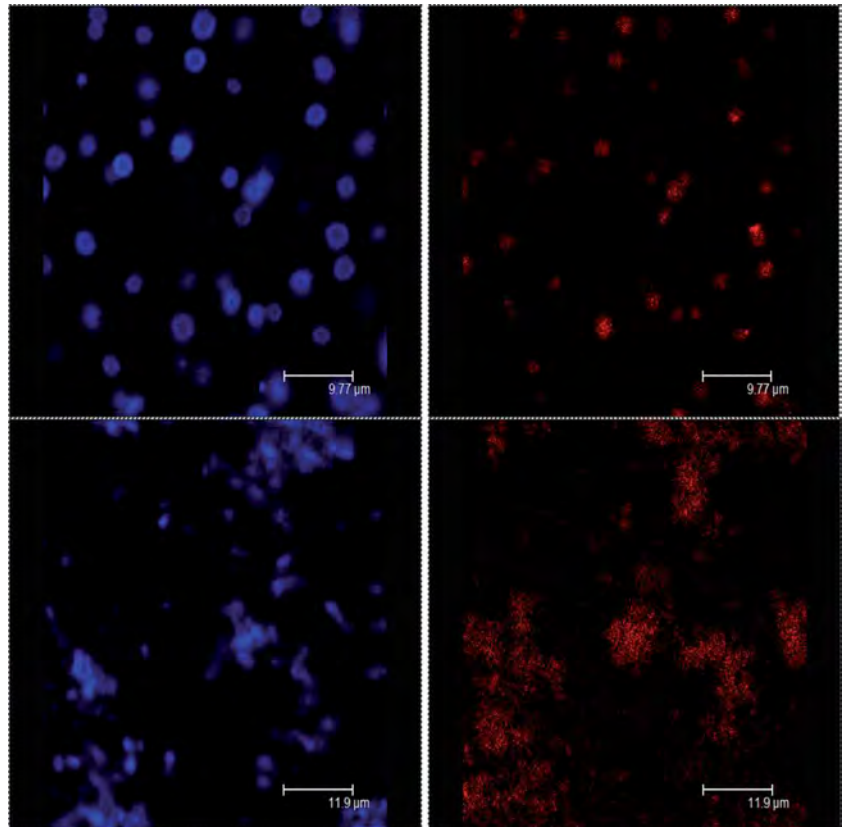

at 600 bar, the extraction yield obtained after 180 min increased by 46 % compared to that at 350 bar. At the latter pressure, the plateau is not reached after 180 min of extraction, which is still in progress. The gradient of the linear part is lower, which is consistent with lower lipid solubility at this pressure. The significant improvement in the total yield observed at high pressure may be because of modifications of the algal wall due to high-pressure extraction of some structural components. The carotenoid yield is slightly improved at 600 bar (8 %), and the pressure has no significant influence on the chlorophyll extraction yield.

#### Pretreatment by bead milling

One of the important characteristics of *C. vulgaris* is the rigidity of its cell wall; it is composed of cellulose, hemicellulose, glucosamine, proteins, lipids and ash (Abo-Shady et al. 1993; Payne and Rippingale 2000). Thus, breaking this cell wall allows solvent accessibility to the intracellular compartments generally leading to an increase in the total extract yield. Microscopic observations revealed complete disruption of the cell wall as shown in Fig. 3, where it can be seen that the cells have completely lost their globular shape after bead milling for 1 h. Microalgae treated by bead milling have then been extracted using pure scCO<sub>2</sub> under the same operating

conditions as for raw microalga, and the extraction kinetics for lipids and pigments are shown in Fig. 4. Although final global yields are almost the same (slightly higher than 10 %), the extraction kinetics are clearly improved by bead milling. At 600 bar, the maximum yield is obtained after 90 min, although 180 min is necessary for a raw material, and the same behaviour is observed for pigments. This result confirms the hypothesis concerning the efficiency of cell disruption with bead milling, because solutes become easily accessible to the solvent, and diffusion limitations are alleviated. Pigment recovery is also significantly affected by bead milling, meaning that this unit operation allows the solvent to access the phospholipid bilayer of the chloroplast where the pigments are mainly located in the thylakoids. Moreover, the global extraction kinetics observed at 350 and 600 bar are, in the case of bead milling, very similar, supporting the hypothesis of extraction being limited by internal diffusion within the cell. Indeed, when the cells are broken open, the lipids are more easily accessible to the solvent, in which case the influence of pressure concerns solute solubility only. Results obtained after bead milling, also confirm conclusions from other studies using different cell disruption methods to crush the *C. vulgaris* cell wall before conducting the extraction by supercritical carbon dioxide (Dejose et al. 2011; Gouveia et al. 2007; Mendes et al. 1995).

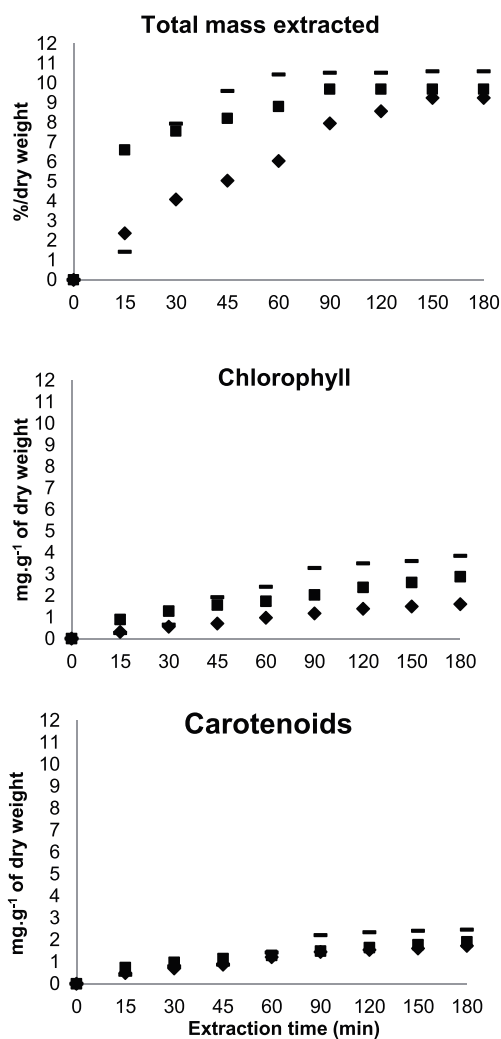
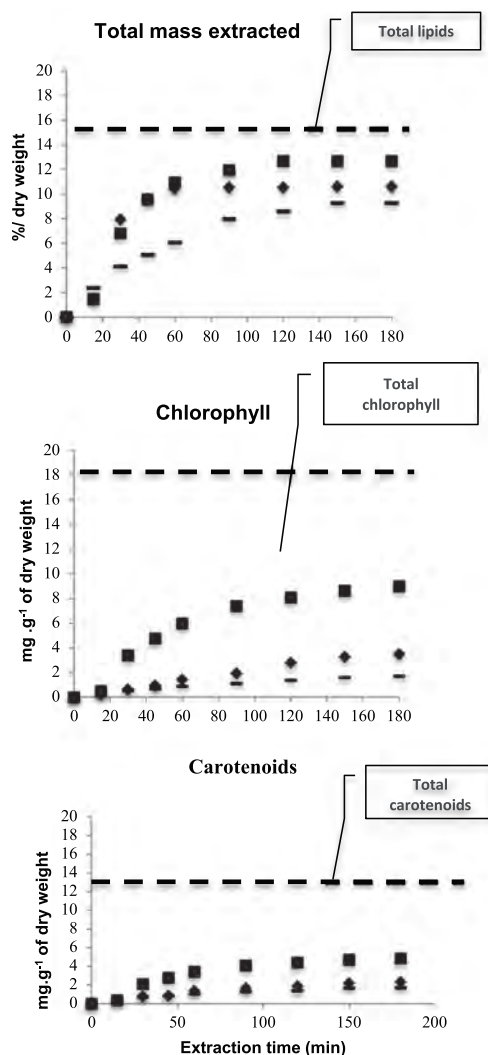

**Fig. 4** Assessing the effect of bead milling on the extraction of the biomolecules: bead milling (600 bar, 30 g min<sup>-1</sup> CO<sub>2</sub> flow rate, 60 °C), bead milling (350 bar, 30 g min<sup>-1</sup> CO<sub>2</sub> flow rate, 60 °C) (square), and raw microalga (600 bar, 30 g min<sup>-1</sup> CO<sub>2</sub> flow rate, 60 °C) (diamond)

#### Extraction with ethanol as a co-solvent

It should be mentioned that *C. vulgaris* was grown under normal growth conditions and was thus expected to have a low lipid content mainly composed of polar lipids. Therefore, given the relatively high polarity of the lipid fraction, it seems pertinent to consider the addition of ethanol as a co-solvent to enhance the solubility of these biomolecules (Fig. 5) as well as that of pigments. Thus, by using the same operating conditions as previously, the addition of 5 % w v<sup>-1</sup> ethanol to scCO<sub>2</sub> when treating raw microalga increased the total extract yield by 27 and 16 % compared to the experiment conducted on raw microalga (without ethanol) and disrupted cells (by bead milling), respectively. Chlorophyll and carotenoids were also significantly affected by the addition of the co-solvent on the raw microalga, with 81 and 65 % enhancement, respectively, compared to the experiment using raw microalga without ethanol,

and by 61 and 52 %, respectively, compared to cells disrupted by bead milling. Furthermore, the concentration of both pigments in the final extract changed according to the treatment applied, and in this respect, the increasing concentration of chlorophyll in the extract followed the trend: no pretreatment (18 %) < bead milling (33 %) < co-solvent (78 %). Similarly, the increasing concentration of carotenoids followed the same trend, but with lower concentrations: no pretreatment (18 %) < bead milling (22 %) < co-solvent (37 %). The effectiveness of adding a co-solvent was also covered in other studies. For instance, these results parallel those by Kitada et al. (2009) on *C. vulgaris* and Nobre et al. (2013) on *Nannochloropsis* sp, where the effect of co-solvent on the solubility of a carotenoid was explained by the presence of highly polar alcohol with carbon dioxide that modifies the characteristics of the solvent, leading to an enhancement of pigment recovery. In addition,



**Fig. 5** Comparison of the effect of different treatments on the extraction of the biomolecules: raw microalga (600 bar, 30 g min<sup>-1</sup> CO<sub>2</sub> flow rate, 5 % ethanol, 60 °C) (square), bead milling (600 bar, 30 g min<sup>-1</sup> CO<sub>2</sub> flow rate, 60 °C) (diamond), and raw microalgae (600 bar, 30 g min<sup>-1</sup> CO<sub>2</sub> flow rate, 60 °C)

although the use of supercritical carbon dioxide without a co-solvent leads to lower extraction yields, the selectivity for carotenoids such as lutein can be slightly improved.

In conclusion, according to the results described above, it can be deduced that high pressure inflicts some damage to the cell wall allowing supercritical carbon dioxide to reach the intracellular space as well as the intra-organelle matrix where the target biomolecules are located. Bead milling is a very effective cell disruption technique that completely breaks down the cells but requires high-energy input that must be considered in the case of future process development. Optimization of bead milling conditions is thus necessary to minimize production costs. Supercritical carbon dioxide is an interesting and selective extraction process, which is still considered costly compared to conventional methods. However, the degree of selectivity is an extremely important factor since it is a key element to bypass multiple unit operations of purification that would decrease the final production cost and simultaneously increase the added value of the final product and compensate for its high production cost. Moreover, regarding the cleanliness of the final product, which is highly important, the presence of ethanol in trace quantities presents no problems as to its implementation in nutritional or pharmaceutical applications.

The study also gathered additional information regarding the necessity for conducting a preliminary cell disruption operation before supercritical carbon dioxide extraction. It was shown that the addition of 5 % w v<sup>-1</sup> ethanol into the supercritical device allowed better recovery of the lipid extract, chlorophyll and carotenoids, compared to the use of preliminary bead milling of *C. vulgaris*. These results were obtained at 600 bar, with a flow rate 30 g min<sup>-1</sup>, at 60 °C, with a 3-h extraction time. However, optimization of extraction conditions may lead to shorter extraction times, and such a perspective will have to be considered with regard to the energy required by the entire purification process. Thus, it would appear worthwhile to conduct additional studies, concerning optimization and implementation of the coupling of both bead milling and supercritical technology on a large scale, in order to achieve reasonable production costs in the near future.

**Acknowledgments** This study was supported by the French National Research Agency (ANR) within the framework of the “Algoraffinerie” project. The authors would like to gratefully thank Alpha Biotech for providing the biomass.

## References

- Abo-Shady AM, Mohamed YA, Lasheen T (1993) Chemical composition of the cell wall in some green algae species. *Biol Plant* 35:629–632
- Becker EW (2007) Micro-algae as a source of protein. *Biotechnol Adv* 25:207–210
- Chisti Y (2007) Biodiesel from microalgae. *Biotechnol Adv* 25:294–306
- Crampon C, Boutin O, Badens E (2011) Supercritical carbon dioxide extraction of molecules of interest from microalgae and seaweeds. *Ind Eng Chem Res* 50:8941–8953
- Crampon C, Mouahid A, Toudji SAA, Lépine O, Badens E (2013) Influence of pretreatment on supercritical CO<sub>2</sub> extraction from *Nannochloropsis oculata*. *J Supercrit Fluids* 79: 337–344
- Dejoye C, Vian MA, Lumia G, Bouscarle C, Charton F, Chemat F (2011) Combined extraction processes of lipid from *Chlorella vulgaris* microalgae: microwave prior to supercritical carbon dioxide extraction. *Int J Mol Sci* 12:9332–9341
- Demirbas MF (2011) Biofuels from algae for sustainable development. *Appl Energy* 88:3473–3480
- Gouveia L (2011) Microalgae as a feedstock for biofuels. *SpringerBriefs in Microbiology*. V, p 68
- Gouveia L, Nobre BP, Marcelo FM, Mrejen S, Cardoso MT, Palavra AF, Mendes RL (2007) Functional food oil coloured by pigments extracted from microalgae with supercritical CO<sub>2</sub>. *Food Chem* 101: 717–723
- Hu Q, Sommerfeld M, Jarvis E, Ghirardi M, Posewitz M, Seibert M, Darzins A (2008) Microalgal triacylglycerols as feedstocks for biofuel production: perspectives and advances. *Plant J* 54:621–639
- Kapaun E, Reisser W (1995) A chitin-like glycan in the cell wall of a *Chlorella* sp. (Chlorococcales, Chlorophyceae). *Planta* 197:577–582
- Kitada K, Machmudah S, Sasaki M, Goto M, Nakashima Y, Kumamoto S, Hasegawa T (2009) Supercritical CO<sub>2</sub> extraction of pigment components with pharmaceutical importance from *Chlorella vulgaris*. *J Chem Technol Biotechnol* 84:657–661
- Konishi F, Tanaka K, Himeno K, Taniguchi K, Nomoto K (1985) Antitumor effect induced by a hot water extract of *Chlorella vulgaris* (CE): resistance to Meth-A tumor growth mediated by CE-induced polymorphonuclear leukocytes. *Cancer Immunol Immunother* 19:73–78
- Li Y, Horsman M, Wu N, Lan CQ, Dubois-Calero N (2008) Biofuels from microalgae. *Biotechnol Progr* 24:815–820
- Lordan S, Ross RP, Stanton C (2011) Marine bioactives as functional food ingredients: potential to reduce the incidence of chronic diseases. *Mar Drugs* 9:1056–1100
- Mallick N, Mandal S, Singh AK, Bishai M, Dash A (2012) Green microalga *Chlorella vulgaris* as a potential feedstock for biodiesel. *J Chem Technol Biotechnol* 87:137–145
- Mendes RL, Fernandes HL, Coelho J, Reis EC, Cabral JMS, Novais JM, Palavra AF (1995) Supercritical CO<sub>2</sub> extraction of carotenoids and other lipids from *Chlorella vulgaris*. *Food Chem* 53:99–103
- Mendes RL, Nobre BP, Cardoso MT, Pereira AP, Palavra AF (2003) Supercritical carbon dioxide extraction of compounds with pharmaceutical importance from microalgae. *Inorg Chim Acta* 356:328–334
- Mizuno Y, Sato A, Watanabe K, Hirata A, Takeshita T, Ota S, Sato N, Zachleder V, Tsuzuki M, Kawano S (2012) Sequential accumulation of starch and lipid induced by sulfur deficiency in *Chlorella* and *Parachlorella* species. *Bioresour Technol* 129C:150–155
- Nemkova Y, Kalina T (2000) Cell wall development, microfibril and pyrenoid structure in type strains of *Chlorella vulgaris*, *C. kessleri*, *C. sorokiniana* compared with *C. luteoviridis* (Trebouxiophyceae, Chlorophyta). *Arch Hydrobiol* 100:95–105
- Nobre BP, Villalobos F, Barragan BE, Oliveira AC, Batista AP, Marques PA, Mendes RL, Sovoda H, Palavra AF, Gouveia L (2013) A biorefinery from *Nannochloropsis* sp. microalga-extraction of oils and pigments. Production of biohydrogen from the leftover biomass. *Bioresour Technol* 135:128–136



- Payne MF, Ripplingale RJ (2000) Evaluation of diets for culture of the calanoid copepod *Gladioferens imparipes*. *Aquaculture* 187:85–96
- Raposo MF, de Morais RM, Bernardo de Morais AM (2013) Bioactivity and applications of sulphated polysaccharides from marine microalgae. *Mar Drugs* 11:233–252
- Ritchie RJ (2006) Consistent sets of spectrophotometric chlorophyll equations for acetone, methanol and ethanol solvents. *Photosynth Res* 89:27–41
- Solomon EP, Berg LR, Martin DW (1999) *Biology*, 5th edn. Saunders College, Fort Worth
- Spolaore P, Joannis-Cassan C, Duran E, Isambert A (2006) Commercial applications of microalgae. *J Biosci Bioeng* 101:87–96
- Widjaja A, Chien C-C, Ju Y-H (2009) Study of increasing lipid production from fresh water microalgae *Chlorella vulgaris*. *J Taiwan Inst Chem E* 40:13–20