

International Institute of Welding
Hungarian Delegation



Institut International de la Soudure
Délégation Hongroise

Optimum design and cost comparison of a welded plate stiffened on one side and a cellular plate both loaded by uniaxial compression

Farkas, J. & Jármai, K.

University of Miskolc, Hungary

IIW-Doc. XV-1191-05, XV-WG9-31-05

Prague, 2005

Abstract

Two types of stiffened plates are used in welded structures as follows: plates stiffened on one side and cellular ones, which consist of stiffeners welded between two deck plates. For a realistic cost comparison each type is optimized for minimum cost in the case of axial compression. Both plates are longitudinally stiffened by halved rolled I-section ribs. The deck plate thickness as well as the dimensions and number of stiffeners are sought, which minimize the cost function and fulfil the design and fabrication constraints. The cost function includes the material and fabrication costs. The design constraints relate to the overall and local plate buckling. It is shown that the cellular plate is cheaper than the plate stiffened on one side, since its large torsional stiffness enables us to use smaller plate thicknesses and smaller stiffener height.

Key words: stiffened plates, minimum cost design, structural optimization, fabrication cost calculation, overall and local plate buckling, economy of welded structures

1. Introduction

Stiffened plate is one of the most frequently used structural component in welded structures. Two types of stiffened plates can be constructed: plate stiffened on one side (in the following briefly *stiffened plate*) and cellular plate (Figs 1 and 2). Cellular plates have some advantages over stiffened ones as follows. (a) their torsional stiffness contributes to the overall buckling strength significantly, therefore their dimensions (height and thickness) can be smaller, (b) their symmetry eliminates the large residual welding distortions, which can occur in stiffened plates due to shrinkage of eccentric welds.

In the present study it is shown that the cellular plates can be cheaper than the stiffened ones. This economy is caused by the advantage mentioned above in (a).

The stiffened and cellular plates have the following structural characteristics:

- loads: uniaxial and biaxial compression, lateral loads, hydrostatic load, static and dynamic (variable) forces;
- material: normal or high-strength steel, aluminium alloys, fiber-reinforced plastics (FRP);
- stiffening topology: stiffening on one, two or more directions;
- stiffener type: flat plate, halved rolled I-section, cold-formed L-shape, trapezoidal;
- fabrication technology: welding, bolting, riveting, bonding (FRP).

In the present study the load is uniaxial compression, the stiffening is constructed with longitudinal halved rolled I-section stiffeners, the material is a higher-strength steel with yield stress of 355 MPa, the fabrication technology is welding (continuous longitudinal fillet submerged arc – SAW-welds).

We have developed a cost calculation method mainly for welded structures [1, 2, 3], by which it is possible to give a realistic cost comparison of optimized structural versions. The cost function includes the costs of material, assembly, welding, post-welding works and painting.

The analysis and optimization of cellular plates have been first treated in the doctoral dissertation of Farkas [4, 5]. The large torsional stiffness of cellular plates is demonstrated by deflection measurements in a welded steel cellular plate model and in a glued plexiglas model. A detailed literature survey is worked out for cellular plates in the book [1]. The book [3] contains studies on stiffened and cellular plates relating to hydrostatic loads, ship deck panels, different kinds of stiffeners, combination of axial compression and lateral load.

This study is a part of our systematic research on economy of welded structures. The economy of some structural types is demonstrated by the comparison of minimum costs of different structural versions. Such a comparison has been performed for various kinds of stiffened cylindrical shells as follows: ring stiffeners, external pressure [6], ring stiffeners, bending [7], stringer stiffeners, axial compression and bending [8], stringer stiffeners, bending [9], ring and stringer stiffeners, axial compression and external pressure [10].

2. Overall buckling strength of orthogonally stiffened uniaxially compressed plates

The Huber's differential equation of uniaxially compressed orthotropic plates is given by

$$B_x w'''' + 2Hw'''' + B_y w'''' + N_x w'' = 0 \quad (1)$$

where the prime (') and dot (·) superscripts denote partial derivatives with respect to x and y respectively. The corresponding bending and torsional stiffnesses are defined as

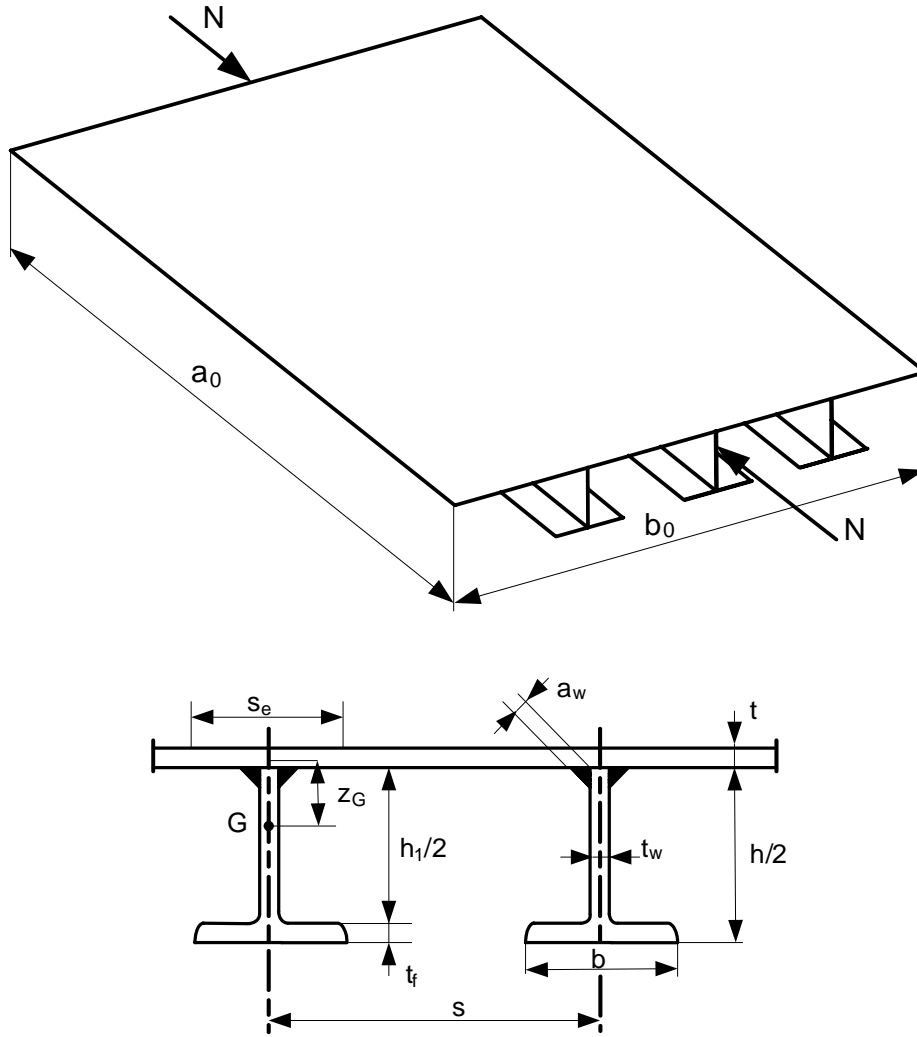

Fig.1. A plate longitudinally stiffened on one side

$$B_x = \frac{E_1 I_y}{a_y}; B_y = \frac{E_1 I_x}{a_x}; E_1 = \frac{E}{1-\nu^2} \quad (2)$$

for cellular plates in the calculation of B_{xy} and B_{yx} the moments of inertia I_y and I_x can be used, since the shear stresses act similarly than the normal stresses due to bending as it is shown in the Appendix in Fig.A2(c).

$$B_{xy} = \frac{GI_y}{a_y}; B_{yx} = \frac{GI_x}{a_x}; G = \frac{E}{2(1+\nu)} \quad (3)$$

$$H = B_{xy} + B_{yx} + \frac{\nu}{2}(B_x + B_y) = \frac{E_1}{2} \left(\frac{I_y}{a_y} + \frac{I_x}{a_x} \right) \quad (4)$$

for plates of quadratic symmetry $H = B_x = B_y$ (4a)

i.e. this calculation of the torsional stiffness shows that it equals to the mean value of bending stiffnesses. This fact is verified by a torsional test of a welded steel cellular plate described in Appendix.

For stiffened plates with open-section stiffeners $B_{xy} = B_{yx} = H \approx 0$

The solution of Eq (1) yields the classic buckling formula for critical force of a simply supported rectangular plate

$$N_E = \frac{\pi^2}{b_0^2} \left(B_x \frac{b_0^2}{a_0^2} + 2H + B_y \frac{a_0^2}{b_0^2} \right) \quad (5)$$

For a cellular plate with longitudinal stiffeners only

$$B_y = E_1 \frac{t(h+2t)^2}{8}, B_{yx} \approx 0, \\ B_{xy} = \frac{Gt(h+2t)^2}{8}, H = B_{xy} + \frac{\nu}{2} B_y + \frac{\nu}{2} B_x \quad (6)$$

For stiffened plates with longitudinal ribs only

$$B_y = 0; N_E = \frac{\pi^2 B_x}{a_0^2} \quad (7)$$

3. The plate stiffened on one side by longitudinal stiffeners (Fig.1)

The buckling constraint according to DNV [11] is given by

$$\sigma = \frac{N}{nA_e} \leq \sigma_{cr} = \frac{f_{y1}}{\sqrt{1+\lambda^4}}, f_{y1} = \frac{f_y}{1.1} \quad (8)$$

$$A_e = \frac{h_1 t_w}{2} + b t_f + s_e t, s = \frac{b_0}{n}, s_E = 1.9t \sqrt{\frac{E}{f_y}} \quad (9)$$

$$\begin{aligned} \text{When } s_E < s \quad s_e &= s_E \\ \text{when } s_E > s \quad s_e &= s \end{aligned} \quad (10)$$

$$\lambda = \sqrt{\frac{f_{y1}}{\sigma_E}}, \sigma_E = \frac{N_E s}{A_e}, N_E = \frac{\pi^2 B_x}{a_0^2} \quad (11)$$

The bending stiffness is defined by

$$B_x = \frac{EI_y}{s} \quad (12)$$

The distance of the gravity centre is

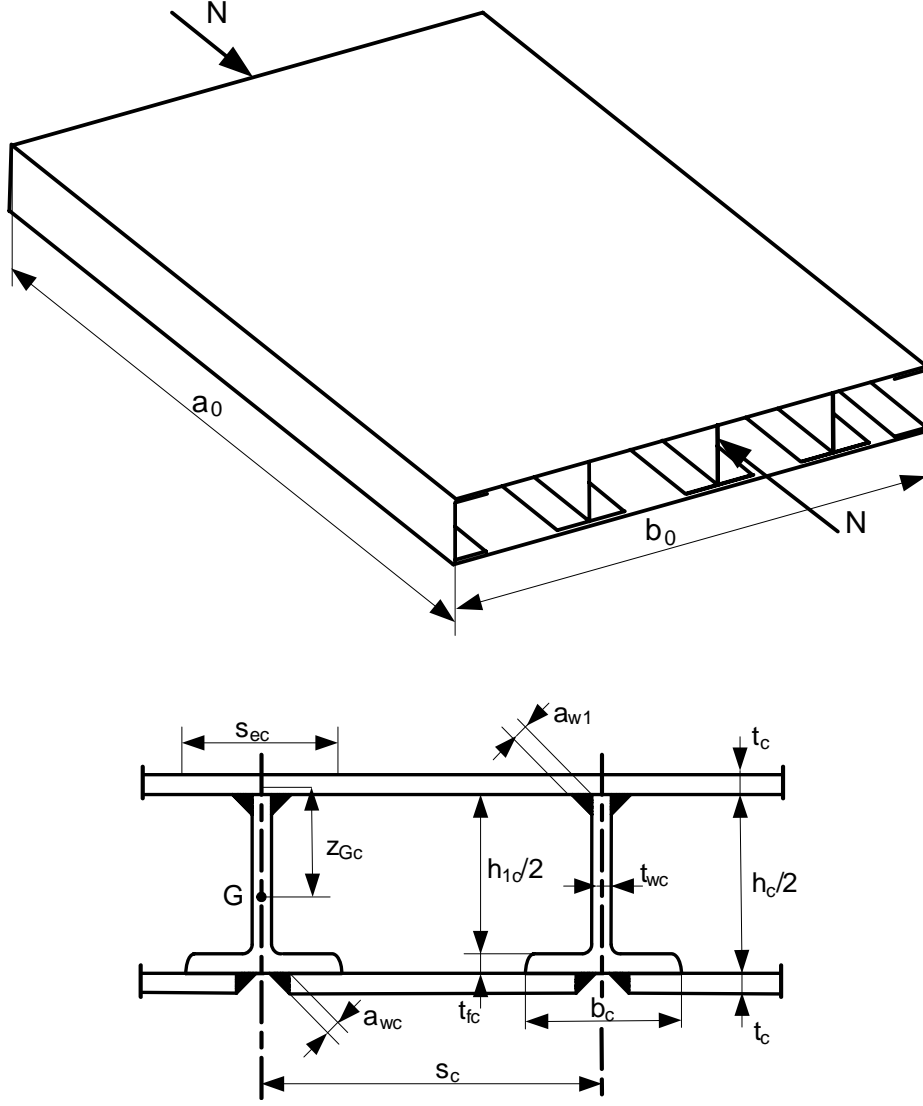

Fig.2. A cellular plate with longitudinal stiffeners

$$z_G = \frac{1}{A_e} \left[\frac{h_1 t_w}{2} \left(\frac{h_1}{4} + \frac{t}{2} \right) + b t_f \left(\frac{h+t-t_f}{2} \right) \right] \quad (13)$$

The moment of inertia is

$$I_y = s_e t z_G^2 + \frac{h_1^3 t_w}{96} + \frac{h_1 t_w}{2} \left(\frac{h_1}{4} + \frac{t}{2} - z_G \right)^2 + b t_f \left(\frac{h+t-t_f}{2} - z_G \right)^2 \quad (14)$$

The fabrication constraint is expressed as

$$s - b \geq 300 \text{ mm} \quad (15)$$

The cost function includes the cost of material and welding

$$K = K_M + K_W \quad (16)$$

$$K_M = k_M \rho V, k_M = 1 \$/kg, \rho = 7.85 \times 10^{-6} \text{ kg/mm}^3 \quad (17)$$

$$V = a_0 b_0 t + (n-1) a_0 \left(\frac{h_1 t_w}{2} + b t_f \right) \quad (18)$$

$$K_w = k_w \left[\Theta \sqrt{n \rho V} + 1.3 C a_w^2 (n-1) 2 a_0 \right] \quad (19)$$

where

$$\Theta = 2, k_w = 1.0 \$/\text{min}, a_w = 0.4 t_w, C = 0.3394 \times 10^{-3} \text{ min/mm}^3$$

The unknowns are as follows: h , n and t .

The other dimensions of a halved rolled I-section are expressed by the main height h according [12] as follows:

$$t_f = \sqrt{33.20533808 + 0.0006701288 h^2}, \quad (20)$$

$$b = \sqrt{5851.784768098 + 0.01671843845 h^2 \ln(h)}, \quad (21)$$

$$t_w = \sqrt{15.62577015376 + 4.358946969 \times 10^{-5} h^2 \ln(h)}, \quad (22)$$

$$h_1 = h - 2t_f. \quad (23)$$

The discrete values of h are according to [13] as follows: 152.4, 177.8, 203.2, 257.2, 308.7, 353.4, 403.2, 454.6, 533.1, 607.6, 683.5, 762.2, 840.7, 910.4 mm.

4. The longitudinally stiffened cellular plate (Fig.2)

The buckling constraint is given by

$$\frac{N}{n_c A_{ec}} \leq \sigma_{crc} = \frac{f_{y1}}{\sqrt{1 + \lambda_c^4}} \quad (24)$$

where

$$A_{ec} = \frac{h_{1c} t_{wc}}{2} + b_c t_{fc} + 2s_{ec} t_c \quad (25)$$

$$s_c = \frac{b_0}{n_c}, s_{Ec} = 1.9 t_c \sqrt{\frac{E}{f_y}} \quad (26)$$

$$\text{when } s_{Ec} < s_c \quad s_{ec} = s_{Ec} \quad (27)$$

$$\text{when } s_{Ec} \geq s_c \quad s_{ec} = s_c$$

$$\lambda_c = \sqrt{\frac{f_{y1}}{\sigma_{Ec}}}, \sigma_{Ec} = \frac{N_{Ec}s}{A_{ec}} \quad (28)$$

$$N_{Ec} = \frac{\pi^2}{b_0^2} \left[B_{xc} \left(\frac{b_0}{a_0} \right)^2 + 2H_c + B_{yc} \left(\frac{a_0}{b_0} \right)^2 \right] \quad (29)$$

where

$$B_{xc} = \frac{E_1 I_{yc}}{s_{1c}}, E_1 = \frac{E}{1-\nu^2} \quad (30)$$

using Eqs (2) and (6)

$$B_{yc} = \frac{E_1 t_c (h_c + 2t_c)^2}{8}, H_c = \frac{B_{yc}}{2} + \frac{\nu B_{xc}}{2} \quad (31)$$

The distance of the gravity centre is

$$z_{Gc} = \frac{1}{A_{ec}} \left[s_{ec} t_c \left(\frac{h_c}{2} + t_c \right) + \frac{h_{1c} t_{wc}}{2} \left(\frac{h_{1c}}{4} + \frac{t_c}{2} \right) + b_c t_{fc} \left(\frac{h_c + t_c - t_{fc}}{2} \right) \right] \quad (32)$$

and the moment of inertia is expressed as

$$I_{yc} = s_{ec} t_c z_{Gc}^2 + s_{ec} t_c \left(\frac{h_c}{2} + t_c - z_{Gc} \right)^2 + \frac{h_{1c}^3 t_{wc}}{96} + \frac{h_{1c} t_{wc}}{2} \left(\frac{h_{1c}}{4} + \frac{t_c}{2} - z_{Gc} \right)^2 + b_c t_{fc} \left(\frac{h_c + t_c - t_{fc}}{2} - z_{Gc} \right)^2 \quad (33)$$

The fabrication constraint is given by

$$s_c - b_c \geq 300mm \quad (34)$$

The cost function includes the material and fabrication costs as follows:

$$K_c = K_{Mc} + K_{Wc} \quad (35)$$

where

$$K_{Mc} = k_M \rho V_c, V_c = 2a_0 b_0 t_c + a_0 (n_c - 1) \left(\frac{h_{1c} t_{wc}}{2} + b_c t_{fc} \right) \quad (36)$$

$$K_{Wc} = k_W \left[\Theta \sqrt{n_c \rho V} + 1.3Ca_{w1}^2 2(n_c - 1)a_0 \right] + k_W \left[\Theta \sqrt{n_c \rho V_c} + 1.3Ca_{wc}^2 2n_c a_0 \right] \quad (37)$$

$$a_{w1} = 0.4t_{wc}, a_{wc} = 0.5t_c, a_{w1\min} = 3mm$$

The unknowns are as follows: n_c, h_c, t_c .

The other dimensions of a halved rolled I-section are expressed by the main height h as follows:

$$t_{fc} = \sqrt{33.20533808 + 0.0006701288 h_c^2}, \quad (38)$$

$$b_c = \sqrt{5851.784768098 + 0.01671843845 h_c^2 \ln(h_c)}, \quad (39)$$

$$t_{wc} = \sqrt{15.62577015376 + 4.358946969 \times 10^{-5} h_c^2 \ln(h_c)}, \quad (40)$$

$$h_{1c} = h_c - 2t_{fc}. \quad (41)$$

5. Numerical data

$b_0 = 8000$, $a_0 = 24000$ mm, $N = 3 \times 10^7$ [N], $f_y = 355$ MPa, $E = 2.1 \times 10^5$ MPa.

Ranges of variables are as follows: $t = 4 - 40$ mm, $h = 152.4 - 910.4$ mm, the maximum value of n is given by the fabrication constraint (Eq.15 or 34)

$$n_{\max} = \frac{b_0}{b + 300} \quad (42)$$

The n_{\max} values are given in the Table 1.

Table 1. n_{\max} - values for rolled I-sections – dimensions in mm

h	152.4	177.8	203.2	257.2	308.7	353.4	403.2	454.6	533.1	607.6	683.5	762.2	840.7	910.4
b	88.7	101.2	133.2	101.9	101.8	126.0	142.2	152.9	209.3	228.2	253.7	266.7	292.4	304.1
n	20	19	18	19	19	18	18	17	15	15	14	14	13	13

6. Minimum cost design of the stiffened plate

The optimal values of unknowns are sought, which minimize the cost K and fulfil the design and fabrication constraints. In the ranges defined above it is easy to find these values by a systematic search. The following tables show the details of this search.

Table 2. Cost K for $h = 910.4$ mm

n	t mm	constraint MPa	K \$
13	11	117<125	60380
12	12	120<128	58290
11	13	124<130	56200
10	14	128<131	54100
9	16	128<131	53540
8	18	128.8<129.0	52970
7	22	117<120	55440
6	27	104<105	59400
5	40	76<77	75500

Table 3. Cost K for $h = 840.7$ mm

n	t mm	constraint MPa	K \$
13	14	110<115	59070
12	15	112<115	57470
11	17	111<113	57400
10	19	109<110	57330
9	23	102<103	60300

Table 4. Cost K for $h = 762.2$ mm

n	t mm	constraint MPa	K \$
14	20	95.9<96.1	67600
13	23	92<93	69380
12	26	88<89	71120
11	30	83.3<83.7	74380
10	38	72<74	83700

In the case of $h = 683.5$ mm the constraint is violated for the maximum $n = 14$ and $t = 40$ mm. Thus, the optimum is $h = 910.4$, $t = 18$ mm, $n = 8$ and $K = 52970$ \$.

7. Minimum cost design of the cellular plate

Similar systematic search can be performed for the cellular plate. The results are summarized in Table 5. It should be mentioned that, for $h \leq 403.2$ mm the fabrication constraint of $a_{wl} \geq 3mm$ is governing instead of $a_{wl} = 0.4t_{wC}$.

Table 5. Optimum values of n_C and t_C (mm) as well as the minimum cost for different values of h_C (mm). The optimum is marked by bold letters

h_C	t_C	n_C	constraint MPa	K_C \$
152.4	7	19	286<292	35214
177.8	7	18	291<304	35173
203.2	7	16	307<312	34816
257.2	7	16	307<318	33355
308.7	6	19	310<319	34115
353.4	6	17	305<320	33561
403.2	5	18	320.6<321.2	32365
454.6	5	16	308<321	33532
533.1	4	13	317<321	32560
607.6	4	11	317<322	32578
683.5	4	10	291<322	34509
762.2	4	8	302.9<322.5	33691
840.7	4	7	313.2<322.6	32437
910.4	4	6	320.4<322.6	31617

8. Comparison of the stiffened and the cellular plate

It can be seen from Tables 2, 3, 4 and 5 that the minimum cost for the stiffened plate is $K_{min} = 52970$ \$ and for the cellular plate is $K_{Cmin} = 31617$ \$, i.e. the cellular version is 41% cheaper than

the stiffened one. This great difference is caused by the different torsional stiffnesses of the two structural types, which allows for the cellular plate to use much more smaller plate thickness and smaller stiffeners than for the plate stiffened on one side. Table 5 shows that there are several local minima available for the cellular plate. Differences between local optima are 3-10 %.

Acknowledgements

The research work was supported by the Hungarian Scientific Research Foundation grants OTKA T38058, T37941.

References

1. Farkas,J., Jármai,K. *Analysis and optimum design of metal structures*. Balkema, Rotterdam-Brookfield, 1997.
2. Jármai,K., Farkas,J. Cost calculation and optimization of welded steel structures. *Journal of Constructional Steel Research* Vol.50. 1999. 115-135.
3. Farkas,J., Jármai,K. *Economic design of metal structures*. Rotterdam, Millpress, 2003.
4. Farkas,J. *Optimum design of metal structures*. Budapest, Akadémiai Kiadó, Chichester, Ellis Horwood, 1984.
5. Farkas,J. *Optimum design of metal structures*. Dissertation for academic degree of doctor of technical science. In Hungarian. Budapest, 1977.
6. Farkas,J., Jármai,K., Snyman,J.A., Gondos,Gy. Minimum cost design of ring-stiffened welded steel cylindrical shells subject to external pressure. *Proc. 3rd European Conf. Steel Structures*, Coimbra, 2002, eds. Lamas,A. and Simoes da Silva, L. Universidade de Coimbra, 2002. 513-522.
7. Farkas,J., Jármai,K., Virág,Z.: Optimum design of a belt-conveyor bridge constructed as a welded ring-stiffened cylindrical shell. *Welding in the World* 48(2004) No.1-2. 37-41.
8. Farkas,J. & Jármai,K.: Optimum design of a welded stringer-stiffened cylindrical shell subject to axial compression and bending. *IIW-Doc. XV-1167-04, XV-WG9-26-04*. Osaka, 2004.
9. Farkas,J., Jármai,K. Optimum design of a welded stringer stiffened cylindrical steel shell loaded by bending. *Eurosteel 2005*, Maastricht, 2005.
10. Jármai,K., Snyman,J.A., Farkas,J. Minimum cost design of a welded orthogonally stiffened cylindrical shell. *Journal of Computers and Structures*, Elsevier Science, 21 p. (under publication)
11. Det Norske Veritas (DNV): *Buckling strength analysis*. Classification Notes No.30.1. Hovik, Norway, 1995.
12. TableCurve 2D: *Users' manual*, Systat Software Inc., 2003.
13. Profil Arbed *Sales program, Structural shapes*. Arcelor Long Commercial, 2001.

Appendix

Verification of the torsional stiffness of cellular plates

A1. Derivation of the fundamental differential equation of an orthotropic plate in the case of a uniform transverse load

On the basis of the theory of plates [A1], the relationships between the in-plane strains and the derivatives of the transverse deflection w are as follows:

$$\varepsilon_x = -z w'', \varepsilon_y = -z w'', \gamma_{xy} = -2z w'' \quad (A1)$$

The formulae for stress components are

$$\sigma_x = E_1(\varepsilon_x + \nu \varepsilon_y) = -E_1 z (w'' + \nu w'') \quad (A2)$$

$$\sigma_y = -E_1 z (w'' + \nu w''), \tau_{xy} = -2G w'' \quad (A3)$$

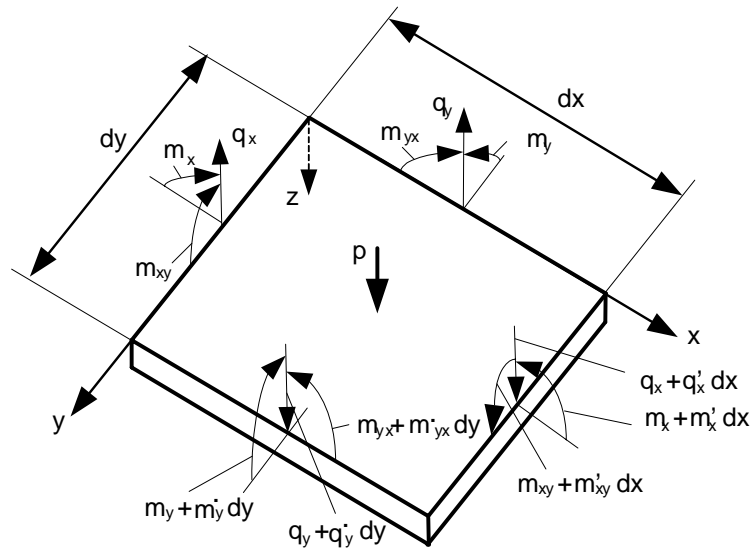

Fig.A1. Equilibrium of an orthotropic plate element

The formulae for the bending and twisting moments per unit length are as follows:

$$m_x = \int \sigma_x z dA = -B_x (w'' + \nu w'') \quad (A4)$$

$$m_y = -B_y (w'' + \nu w'') \quad (A5)$$

$$m_{xy} = \int \tau_{xy} z dA = 2B_{xy} w'', m_{yx} = -2B_{yx} w'' \quad (A6)$$

From the equilibrium equations of a plate element (Fig.A1) one obtains

$$q_x = m_x' + m_{xy}' = -[B_x w'''' + (2B_{yx} + \nu B_x) w'''] \quad (A7)$$

$$q_y = m_y - m_{xy} = -[B_y w'''' + (2B_{xy} + \nu B_y) w'''] \quad (A8)$$

and $q_x + q_y + p = 0$ (A9)

Inserting (A7) and (A8) into (A9) yields the Huber's equation for orthotropic plates in the case of a uniform transverse load

$$B_x w'''' + 2H w'''' + B_y w'''' = p \quad (A10)$$

where $H = B_{xy} + B_{yx} + \frac{\nu}{2}(B_x + B_y)$ (A11)

is the torsional stiffness of an orthotropic plate [A2].

A2. Verification of the torsional stiffness by a torsional test on a welded steel cellular plate model

The torsional stiffness of an anisotropic plate can be experimentally determined by measuring the deflection of the free corner of a quadratic plate supported at four corners (Fig.A2). For this purpose a welded steel cellular plate model has been used (Fig.A3) [A3, A4].

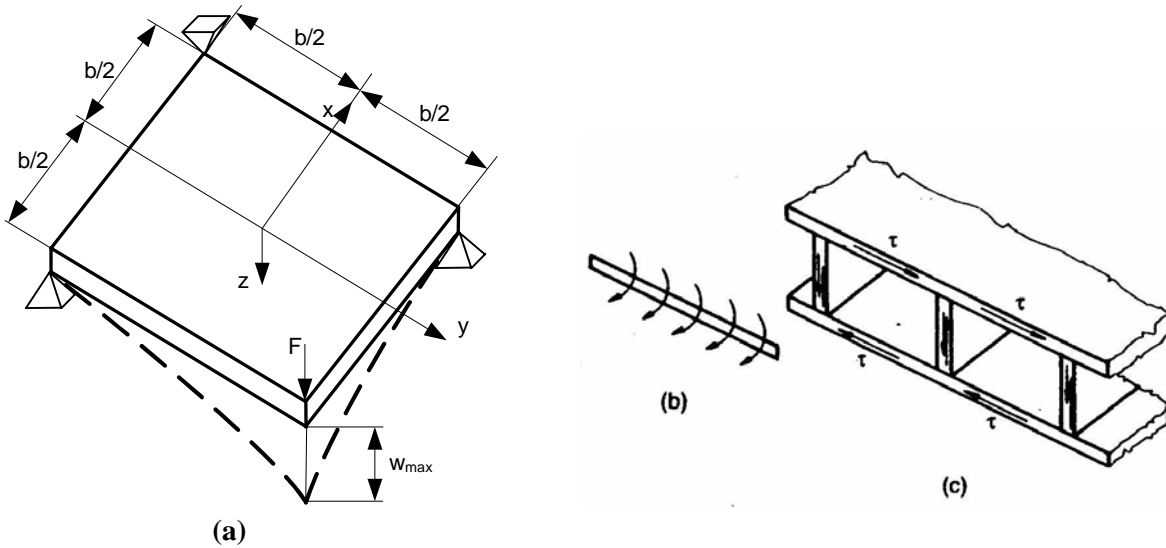

Fig.A2. (a) A quadratic plate supported at four corners, (b) torsional moments acting on a side, (c) shear stresses in a cellular plate due to torsion

The corner deflection can be derived as follows. Using a force F acting on the free corner, the specific torsional moment in one direction is $m_{xy} = -F/2$. In the case of quadratic symmetry the torsional stiffness (A11) is

$$H = 2B_{xy} + \nu B_x \quad (A12)$$

and from (A12) one obtains

$$2B_{xy} = H - \nu B_x \quad (A13)$$

Our aim is to verify that the torsional stiffness of a cellular plate equals to its bending stiffness i.e.

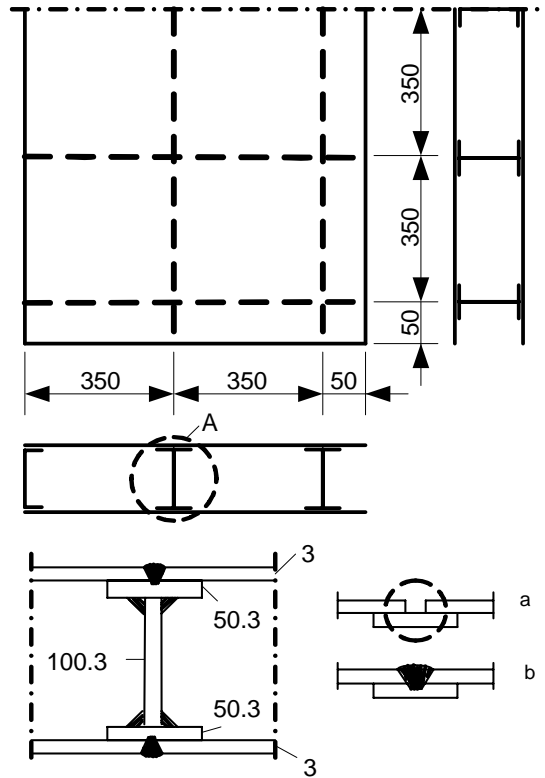

Fig.A3. Dimensions of the welded steel cellular plate model

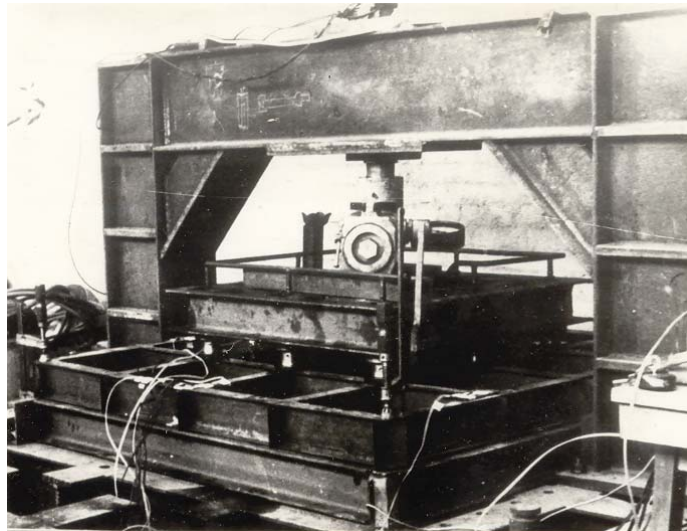

Fig.A4. Measurement of the cellular plate model

$H = B_x$ as it is calculated using formulae of Eq.(4) and (4a). In this case (A6) can be written as

$$m_{xy} = H(1-\nu)w'' = -F/2 \quad (\text{A14})$$

$$\text{or } w'' = \frac{F}{2H(1-\nu)} \quad (\text{A15})$$

Integrating (A15) two times and using the boundary conditions

$$w(x = y = b/2) = 0, w(x = y = -b/2) = 0, w(x = -y = b/2) = 0 \quad (\text{A16})$$

one obtains

$$w = -\frac{F}{2H(1-\nu)} \left(xy + \frac{b}{2}x - \frac{b}{2}y - \frac{b^2}{4} \right) \quad (\text{A17})$$

The deflection due to bending of the point $x = y = -b/2$ is

$$w_{b.\max} = \frac{Fb^2}{2H(1-\nu)} \quad (\text{A18})$$

and the whole deflection considering also the shear deflection is

$$w_{\max} = \frac{Fb^2}{2H(1-\nu)} + \frac{Fb}{2A_w G} = w_{b.\max} + w_q \quad (\text{A19})$$

where A_w is the cross-sectional area of a stiffener web. If w_{\max} is measured, the torsional stiffness can be calculated from (A19) as

$$H = \frac{Fb^2}{2(w_{\max} - w_q)(1-\nu)} \quad (\text{A20})$$

The deflection due to a force $F = 40$ kN was $w_{\max} = 12.94$ mm, $b = 1400$ mm, $w_q = 1.17$ mm, from (A20) one obtains

$$H = 4.76 \times 10^9 \text{ Nmm.}$$

Since the stresses in the plate due to $F = 40$ kN are small, it is not necessary to consider an effective plate width for the deck plates.

The moment of inertia of a stiffener is

$$I_{xs} = \frac{3 \times 100^3}{12} + 2 \times 150 \times 51.5^2 = 1.0457 \times 10^6 \text{ mm}^4.$$

The value of H obtained from measurement can be compared to the following bending stiffness

$$B_x = E \left(\frac{I_{xs}}{a} + \frac{t_f h_1^2}{2(1-\nu^2)} \right) = 2.1 \times 10^5 \left(\frac{1.0457 \times 10^6}{350} + \frac{3 \times 109^2}{0.91 \times 2} \right) = 4.74 \times 10^9 \text{ Nmm.}$$

It can be seen that the measured torsional stiffness equals to the calculated bending stiffness, thus, it is verified that the torsional stiffness of a cellular plate equals to its bending stiffness. Therefore a cellular plate can be calculated as an isotropic one.

References

- A1. Timoshenko, S.P. & Woinowsky-Krieger, S. Theory of plates and shells. 2nd ed. McGraw Hill, New York, 1959.
- A2. Farkas, J. Structural synthesis of welded cell-type plates. Acta Techn. Acad. Sci. Hungaricae 83 (1976) No.1-2. 117-131.
- A3. Farkas, J. Static investigations and optimum design of welded cell-type plates. In Hungarian. Gép 26 (1974) 233-238.