

ISBN : 978-1-4799-64314



2014

The 1st International Conference
on Information Technology,
Computer, and Electrical Engineering

ICITACEE

Semarang, 8-9 November 2014

PROCEEDINGS

*Green Technology and its Applications
for a Better Future*



UNDIP | UNIVERSITAS
DIPONEGORO
becomes an excellent research university



IEEE



Kyutech
Kyushu Institute of Technology

GREETINGS FROM THE GENERAL CHAIR

Welcome to 2014 1st International Conference on Information Technology, Computer, And Electrical Engineering (ICITACEE) held in Semarang, the capital city of Central Java! This conference provides a forum for researchers, academicians, professionals, and students from various engineering backgrounds and also from cross-disciplinary research in the development and the design of Information Technology & Computer, Power System, Circuit & Control, and Communication Systems, as well as the Interdisciplinary topics to interact and to disseminate the latest issues and research.

The ICITACEE 2014 is held in the ICT building of Diponegoro University on November, 8. Three distinguished scholars will start the session as keynote speakers: Prof. Hiroshi Ochi as a wireless expert from Kyushu Institute of Technology Japan, Dr. Trio Adiono as an IC design expert from Bandung Institute of Technology, and Mr. Adi Rahman Adiwoso as an aeronautics expert from PT Pasific Satellite Nusantara. We are very grateful for them to share their knowledge, experience, and their motivation for always doing the best. We recently received more than 140 papers, however only of 87 high quality papers were accepted and being presented in this event. All the accepted and presented papers will be then published in the IEEE Xplore (ISBN 978-1-4799-6432-1). We will select the best papers of each categories mentioned above.

Organizing such an ambitious conference has always been incredibly challenging and would have been impossible to happen without our outstanding committee supports. I would like to thanks all staffs of Department of Electrical Engineering and Department of Computer System as well as IEEE Student Branch of Diponegoro University. They have been working very hard and been always providing me with unprecedented support, advice, and kind assistance on all aspects of the conference. Special thanks goes to the IEEE Indonesia Section, Cisco, Des Net, and PSN for all support to ICITACEE 2014. I also would like to thank all of the steering committee, technical program committee, reviewers, authors, session organizers and chairs, and other volunteers and participants. I expect that everyone is able to enjoy some of what Semarang City has to offer! Hopefully The ICITACEE 2014 conference would become the event of our best deeds.



Wahyul Amien Syafei

General Chair,

2014 1st International Conference of Information Technology,
Computer and Electrical Engineering (ICITACEE)

FOREWORD FROM HEAD OF DEPARTMENT OF ELECTRICAL ENGINEERING, UNIVERSITAS DIPONEGORO, SEMARANG-INDONESIA

It is pleasant to welcome all the participants in the International Conference on Information Technology, Computer, and Electrical Engineering (ICITACEE 2014) at Semarang. This is the second conference held together by Electrical Engineering Department and Computer System Department of Engineering Faculty Universitas Diponegoro. I would like to welcome several keynote speakers from Kyushu Institute of Technology Japan and Institut Teknologi Bandung.

As the Chief of Electrical Engineering Department Universitas Diponegoro, I would like to appreciate the vast work in this conference as collaborative effort among Electrical Engineering Department, Computer System Department Universitas Diponegoro, IEEE Student Branch of Universitas Diponegoro and IEEE Indonesia Section. I also wish that this conference to be a needed forum for engineers and scientist to communicate and sharing their findings and precious researches.

I would like to express hearty gratitude to Organizing Committee members, staffs, and students of Electrical Engineering and Computer System Department of Universitas Diponegoro for their efforts and supports. I do expect that this conference will give important contribution to development of Electrical Engineering and Computer Science locally and internationally.



Ir. Agung Warsito. D.H.E.T

Head, Department of Electrical Engineering – Faculty of Engineering
Universitas Diponegoro, Semarang – Indonesia
and
Vice Chairman of FORTEI (Indonesia Electrical Engineering Forum)

FOREWORD FROM DEAN OF FACULTY OF ENGINEERING UNIVERSITAS DIPONEGORO, SEMARANG – INDONESIA

The International Conference on Information Technology, Computer, and Electrical Engineering (ICITACEE 2014) is now held in Semarang, Indonesia and being organized under the collaborative committee effort among Electrical Engineering and Computer System Department Diponegoro University and IEEE (Institute of Electrical and Electronics Engineers) Indonesia Section. This event also becomes a part of 56th Faculty of Engineering Dies Natalis and 57th Diponegoro University Dies Natalis agenda

The goals of the conference are to obtain and extend the knowledge of the recent issues, opinions, bright ideas about the development of a comprehensive green technology constructively from distinguish scholars, researchers, and academics. Furthermore, this forum is expected to bring new innovations in technology for a better future, especially in the field of information technology, computers, and electrical engineerings and also create cooperation between institutions of science at the college level, industries and government.

It is a great pleasure to welcome all the participants of this conference and also several keynote speakers from Kyushu Institute of Technology Japan, Bandung Institute of Technology and Pasific Satelite Nusantara.

I do hope that this conference to be a valuable forum for engineers and scientist to share their precious researches and this event will give significant contributions to the development of Electrical Engineering and Computer Science. It is hope that this conference will rise the awareness of scientific community members in bringing better life.

I hope that the conference will be stimulating and memorable for you. So, enjoy your time in Semarang.



Ir. Bambang Pudjianto, M.T.
Dean, Faculty of Engineering
Universitas Diponegoro, Semarang – Indonesia

ICITACEE COMMITTEE

General Chair : Wahyul Amien Syafei

Co- Chair : R. Rizal Isnanto

ORGANIZING COMMITTEE:

Adian Fatchur Rochim

Sukiswo

Mochammad Facta

Ajub Ajulian Zahra

Aris Triwiyatno

Eko Didik Widiyanto

Sumardi

Achmad Hidayatno

Yuli Christyono

Munawar Agus Riyadi

Dania Eridani

Darjat

STEERING COMMITTEE :

Muhammad Nuh (Indonesian Ministry of National Education)

Trio Adiono (IEEE Solid State Circuit Indonesian Chapter)

Wahyul Amien Syafei (Diponegoro University)

Hiroshi Ochi (Kyushu Institute of Technology, Japan)

Hiroshi Furukawa (Kyushu University, Japan)

Kuncoro Wastuwibowo, Ir. MSc. (IEEE Indonesian Section)

Onil Nazra Persada (France)

Mauridhi Heri Purnomo (Sepuluh November Institute of Technology)

Razali Ismail (University Teknologi Malaysia, Malaysia)

Taufik (California Polytechnic State, USA)

TECHNICAL PROGRAM COMMITTEE :

Masayuki Kurosaki (Kyushu Institute of Technology)
Eko Handoyo (Utrecht University, Netherland)
R. Rizal Isnanto (Diponegoro University)
Mochammad Facta (Diponegoro University)
Munawar Agus Riyadi (Diponegoro University) Aris
Triwiyatno (Diponegoro University)
Sidiq Syamsul H (State Polytechnics of Semarang) Trio
Adiono (Bandung Institute of Technology)
Adhi Susanto (Gadjah Mada University)
Paulus Insap Santosa(Gadjah Mada University)
Ismail Sa'ad (University Technology Malaysia) Azli
Yahya (University Technology Malaysia) Hendra
Setiawan (Indonesian Islamic University)
Slamet Riyadi (Soegijapranoto Catholic University)
Supari (Semarang University)
Onil Nazra Persada (CEA, France)
M. Hadin (Sultan Agung Islamic University)
Teguh Prakoso (Diponegoro University)
Sri Ratna Sulistiyanti (Lampung University)
Ratna Wardani (Yogyakarta State University)
Suryani Alifah (Sultan Agung Islamic University)
Florentinus Budi Setiawan (Soegijapranoto Catholic University)
Rahmat Budiarto (Al Baha University, Saudi Arabia)
Abdul Kadir (Gajah Mada University)
Junaidi (Universiti Teknologi Malaysia)
Muhammad Aziz Muslim (Brawijaya University)
Muhammad Amjad (The Islamia University of Bahawalpur, Pakistan)
Bahniman Ghosh (Indian Institute of Technology Kanpur, India)

2014 1st International Conference on Information Technology, Computer and
Electrical Engineering (ICITACEE)

CONFERENCE PROGRAM

SATURDAY, 8 NOVEMBER 2014

7:30 - 8:00	Registration			
8:00- 8:45	Opening ceremony			
	Photo session			
8:45 - 9:00	Coffee break			
9:00 - 9:50	Invited speaker 1: Prof. Hiroshi Ochi (<i>Kyushu Institute of Technology, JAPAN</i>) <i>Multi-MIMO Wireless System - from Theory to Chip Design</i>			
9:50 - 10:40	Invited speaker 2: Prof. Dr. Trio Adiono (Institut Teknologi Bandung) <i>Challenges and Opportunities in Designing Internet of Things</i>			
10:40 - 11:30	Invited speaker 3: Dr. Adi Rahman Adiwoso (PT. Pasifik Satelit Nusantara) <i>Role of Satellite Telecommunication in Indonesia</i>			
11:30 - 12:30	LUNCH BREAK			
12:30 - 15:00	Parallel session 1			
	ROOM A	ROOM B	ROOM C	ROOM D
15:00 - 15:15	coffee break			
15:15 - 17:30	Parallel session 2			
	ROOM A	ROOM B	ROOM C	ROOM D
18:30 - 20:00	GALA DINNER			

SUNDAY, 9 NOVEMBER 2014

8:00 - ...	<i>cultural program (city tours) (*with additional arrangements)</i>
------------	--

PARALLEL SESSION

TIME	NO	ROOM A (HALL, 5th FLOOR)		ROOM B (5th FLOOR)		ROOM C (4th FLOOR)		ROOM D (4th FLOOR)	
		CODE	TITLE	CODE	TITLE	CODE	TITLE	CODE	TITLE
12.30 - 15.00	1	PS01	Design and Implementation of Solar Power as Battery Charger Using Incremental Conductance Current Control Method based on dsPIC30F4012	IP01	Visual Object Tracking using Particle Clustering	CC01	Enhancement of DRAMs Performance using Resonant Tunneling Diode Buffer	ITC01	The Development of 3D Educational Game to Maximize Children's Memory
	2	PS02	An Adaptive Neuro Fuzzy Inference System for Fault Detection in Transformers by Analyzing Dissolved Gases	IP02	Selective Encryption of video MPEG use RSA Algorithm	CC02	Real-time SoC Architecture and Implementation of Variable Speech PDF based Noise Cancellation System	ITC02	The Influence of Knowledge Management to Successful Collaborative Design
	3	PS03	Optimal Power Flow based upon Genetic Algorithm deploying Optimum Mutation and Elitism	IP03	Analytical Hierarchy Process for Land Suitability Analysis	CC03	Application of Supervised Learning in Grain Dryer Technology Recirculation Type Cooperated with Wireless Sensor Network	ITC03	Knowledge and Protocol on Collaborative Design Selection
	4	PS04	Design Analysis and Optimization of Ground Grid Mesh of Extra High Voltage Substation Using an Intelligent Software	IP04	Training Support for Pouring Task in Casting Process using Stereoscopic Video See-through Display - Presentation of Molten Metal Flow Simulation Based on Captured Task Motion -	CC04	Design of Real-Time Gas Monitoring System Based-on Wireless Sensor Networks for Merapi Volcano	ITC04	Mobile-Based Learning Design with Android Development Tools
	5	PS05	Design and Simulation of Neural Network Predictive Controller Pitch-Angle Permanent Magnetic Synchronous Generator Wind Turbine Variable Pitch System	IP05	Feature Extraction and Classification of Heart Sound based on Autoregressive Power Spectral Density	CC05	ANFIS Application for Calculating Inverse Kinematics of Programmable Universal Machine for Assembly (PUMA) Robot	ITC05	A mobile diabetes educational system for Fasting Type 2 Diabetes in Saudi Arabia
	6	PS06	Inverse Clarke Transformation based Control Method of a Three-Phase Inverter for PV-Grid Systems	IP06	Smart-Meter based on current transient signal signature and constructive backpropagation method	CC06	MRC NN Controller for Arm Robot Manipulator	ITC06	Aggressive Web Application Honeypot for Exposing Attacker's Identity
	7	PS07	Control of a Single Phase Boost Inverter with the Combination of Proportional Integrator and Hysteresis Controller	IP07	AUTOMATIC DOORSTOP SAFETY SYSTEM BASED ON IMAGE PROCESSING WITH WEBCAM AND SCANNER	CC07	Development of Microcontroller-based Stereoscopic Camera Rig Positioning System	ITC07	Adjustment Levels for Intelligent Tutoring System using Modified Items Response Theory
	8	PS08	A Simple Three-phase Three-wire Voltage Disturbance Compensator	IP08	Palprint Identification for User Verification based on Line Detection and Local Standard Deviation	CC08	Design of A Digital PI Controller for Room Temperature on Wireless Sensor and Actuator Network (WSAN) System	ITC08	Smile Recognition System based on Lip Corners Identification
	9	PS09	Analysis of Protection Failure Effect and Relay Coordination on Reliability Index	IP09	Cerebellar Model Articulation Controller (CMAC) for Sequential Images Coding	CC09	Display and Interface of wireless EMG measurements	ITC09	An Integrated Framework for Measuring Information System Success Considering the Impact of Culture in Indonesia
	10	PS10	Extreme Learning Machine Approach to Estimate Hourly Solar Radiation On Horizontal Surface (PV) in Surabaya - East Java	IP10	A Comparative Study on Signature Recognition	CC10	Accuracy Enhancement of Pickett Tunnelling Barrier Memristor Model	ITC10	Pre-Processing Optimization on Sound Detector Application AudiTion (Android Based Supporting Media for the Deaf)
COFFEE BREAK									
15.15 - 17.30	11	PS11	Maximum Power Point Tracking Control for Stand-Alone Photovoltaic System using Fuzzy Sliding Mode Control Maximum Power Point Tracking Control for Stand-Alone Photovoltaic System using Fuzzy Sliding Mode Control	IP11	Study of Environmental Condition Using Wavelet Decomposition Based on Infrared Image	CC11	Data Fusion and Switching Function For UAV Quadrotor Navigation System	ITC11	EVALUATION OF DISTRIBUTION NETWORK RELIABILITY INDEX USING LOOP RESTORATION SCHEME
	12	PS12	The Influence of Meteorological Parameters under Tropical Condition on Electricity Demand Characteristic: Indonesia Case Study	IP12	Very High Throughput WLAN System for Ultra HD 4K Video Streaming	CC12	Data logger Management Software Design for Maintenance and Utility in Remote	ITC12	Efficient Message Security Based Hyper Elliptic Curve Cryptosystem (HECC) for Mobile Instant Messenger
	13	PS13	Optimal Distribution Network Reconfiguration with Penetration of Distributed Energy Resources	IP13	Iris Recognition Analysis Using Biorthogonal Wavelets Transform for Feature Extraction	CC13	Investigation of Electrical Properties of Nanofibre Polyaniline Synthesize as Material for Sensor	ITC13	Application of Web-Based Information System in Production Process of Batik Industry Design Division
	14	PS14	Maximum Power Point Tracking Photovoltaic Using Root Finding Modified Bisection Algorithm	TE01	Data Rate of Connections Versus Packet Delivery of Wireless Mesh Network with Hybrid Wireless Mesh Protocol and Optimized Link State Routing Protocol	CC14	Reconfigurable Floating Point Adder	ITC14	Managing and Retrieval of Cultural Heritage Multimedia Collection Using Ontology
	15	PS15	Design of LLC Resonant Converter for Street Lamp Based On Photovoltaic Power Source	TE02	Empirical Studies of Wireless Sensor Network Energy Consumption for Designing RF Energy Harvesting	CC15	HOVER POSITION CONTROL WITH FUZZY LOGIC	ITC15	Individual Decision Model for Urban Regional Land Planning

16	PS16	Power Loss Reduction Strategy of Distribution Network with Distributed Generator Integration	TE03	Modulation Performance in Wireless Avionics Intra Communications (WAIC)	CC16	METHODOLOGY OF FUZZY LOGIC WITH MAMDANI FUZZI MODELS APPLIED TO THE MICROCONTROLLER	ITC16	Enhancing Online Expert System Consultation Service with Short Message Service Interface
17	PS17	Double Dielectric Barrier Discharge Chamber for Ozone Generation	TE04	Implementation and Performance Analysis of Alamouti Algorithm for MIMO 2 ¹ —2 Using Wireless Open-Access Research Platform (WARP)	CC17	Fall Detection System Using Accelerometer and Gyroscope Based on Smartphone	ITC17	Mobile Nutrition Recommendation System For 0-2 Year Infant
18	PS18	Leakage Current Characteristics at Different Shed of Epoxy Resin Insulator under Rain Contaminants	TE05	Period Information Deviation on the Segmental Sinusoidal Model	CC18	Design and Implementation of Sensor Fusion for Inertia Measurement on Flying Robot Case Study: Hexacopter	ITC18	Comparison of Distance and Dissimilarity Measures for Clustering Data with Mix Attribute Types
19	PS19	Transformer monitoring using harmonic current based on wavelet transformation and probabilistic neural network (PNN)	TE06	A Compact Dual-band Antenna Design using Meander-line Slots for WiMAX Application in Indonesia	CC19	Triple Band Bandpass Filter With Cascade Tri Section Stepped Impedance Resonator	ITC19	Determining E-commerce Adoption Level by SMEs in Indonesia Based on Customer-Oriented Benefits
20			TE07	Design and Analysis of Dualband J-Pole Antenna with Variation in T-Shape for Transceiver Radio Communication at VHF and UHF Band	CC20	Temperature Response Analysis Based on Pulse Width Irradiation of 2.45 GHz Microwave Hyperthermia	ITC20	Providing Information Sources Domain for Information Seeking Agent From Organizing Knowledge
21			TE08	Low Cost Implementation for Synchronization in Distributed Multi Antenna Using USRP/GNU-Radio	ITC24	Visualization of Condition Irrigation Building and Canal Using Web GIS Application	ITC21	Decision Support System For Stock Trading Using Decision Tree Technical Analysis Indicators and Its Sensitivity Profitability Analysis
22			TE09	Development of the First Indonesian S-Band Radar	ITC25	Comparison of three back-propagation architectures for interactive animal names utterance learning	ITC22	Design Web Service Academic Information System Based Multiplatform
23					ITC26	WORK IN PROGRESS - OPEN EDUCATION METRIC (OEM) : DEVELOPING WEB-BASED METRIC TO MEASURE OPEN EDUCATION SERVICES QUALITY	ITC23	Effects of VANET's Attributes on Network Performance

TABLE OF CONTENTS

[Cover](#)

[Greetings and Thanks from the General Chair](#)

[Foreword from Head of Department of Electrical Engineering,](#)

[Foreword from Dean, Faculty of Engineering](#)

[Organizing Committee](#)

[Steering Committee](#)

[Technical Program Committee](#)

[Keynote Speaker's Biography](#)

[Conference Program](#)

[Keynote's Papers](#)

[Author Index](#)

KEYNOTE SPEAKERS

I-1	Multi-User MIMO Wireless System -From Theory to Chip Design <i>Prof. Hiroshi Ochi</i>	1
I-2	Challenges and Opportunities in Designing Internet of Things <i>Prof. Dr. Trio Adiono</i>	11
I-3	Role of Telecommunication Satellite in Indonesia <i>Adi Rahman Adiwoso</i>	13

CIRCUITS AND SYSTEMS

CC1	Enhancement of DRAMs Performance using Resonant Tunneling Diode Buffer <i>Ahmed LutfiElgreatly, Ahmed AhmedShaaban, El-Sayed M. El-Rabaie</i>	14
CC2	Real-time SoC Architecture and Implementation of Variable Speech PDF based Noise Cancellation System <i>Aditya Ferry Ardyanto, Idham Hafizh, Septian Gilang Permana Putra, Trio Adiono</i>	19
CC3	Application of Supervised Learning in Grain Dryer Technology Recirculation Type Cooperated with Wireless Sensor Network <i>Sidiq Syamsul Hidayat, TotokPrasetyo, Amin Suharjono, Kurnianingsih, Muhammad Anif</i>	24
CC4	Design of Real-Time Gas Monitoring System Based-on Wireless Sensor Networks for Merapi Volcano <i>B. Supriyo, S.S.Hidayat, A. Suharjono, M.Anif, Sorja Koesuma</i>	28
CC5	ANFIS Application for Calculating Inverse Kinematics of Programmable Universal Machine for Assembly (PUMA) Robot <i>Hugo Adeodatus Hendarto, Munadi, Joga Dharma Setiawan</i>	33
CC6	MRC NN Controller for Arm Robot Manipulator <i>Hugo Adeodatus Hendarto, Munadi, Joga Dharma Setiawan</i>	39

CC7	<u>Development of Microcontroller-based Stereoscopic Camera Rig Positioning System</u> <i>Julian Ilham, Wan-Young Chung</i>	44
CC8	<u>Design of A Digital PI Controller for Room Temperature on Wireless Sensor and Actuator Network (WSAN) System</u> <i>Bambang Sugiarto, ElanDjaelani</i>	50
CC9	<u>Display and Interface of wireless EMG measurements</u> <i>Kevin Eka Pramudita, F. Budi Setiawan, Siswanto</i>	56
CC10	<u>Accuracy Enhancement of Pickett Tunnelling Barrier Memristor Model</u> <i>Ahmad A. Daoud, Ahmed A. Shaaban, Sherif M. Abuelenin</i>	61
CC11	<u>Data Fusion and Switching Function For UAV Quadrotor Navigation System</u> <i>Muhammad Faris, Adha Imam Cahyadi, Hanung Adi Nugroho</i>	66
CC12	<u>Data logger Management Software Design for Maintenance and Utility in Remote</u> <i>Devi Munandar, Djohar Syamsi</i>	72
CC13	<u>Investigation of Electrical Properties of NanofibrePolyaniline Synthesize as Material for Sensor</u> <i>Ngurah Ayu Ketut Umiati, Siti Nurrahmi, Kuwat Triyana, Kamsul Abraha</i>	77
CC14	<u>Reconfigurable Floating Point Adder</u> <i>Vipin Gemini</i>	81
CC15	<u>HOVER POSITION CONTROL WITH FUZZY LOGIC</u> <i>Nia Maharani Raharja ,Iswanto, Muhammad Faris, Adha Imam Cahyadi.</i>	87
CC16	<u>METHODOLOGY OF FUZZY LOGIC WITH MAMDANI FUZZI MODELS APPLIED TO THE MICROCONTROLLER</u> <i>Indra Sakti</i>	91
CC17	<u>Fall Detection System Using Accelerometer and Gyroscope Based on Smartphone</u> <i>Arkham Zahri Rakhman, Lukito Edi Nugroho, Widyawan, Kurnianingsih</i>	97
CC18	<u>Design and Implementation of Sensor Fusion for Inertia Measurement on Flying Robot Case Study: Hexacopter</u> <i>Huda Ubaya, Afdhal Akrom</i>	103
CC19	<u>Triple Band Bandpass Filter With Cascade Tri Section Stepped Impedance Resonator</u> <i>Gunawan Wibisono, Tierta Syafraditya</i>	109
CC20	<u>Temperature Response Analysis Based on Pulse Width Irradiation of 2.45 GHz Microwave Hyperthermia</u> <i>Imam Santoso, Thomas Sri Widodo, Adhi Susanto, Maesadjie Tjokronagoro</i>	113
 IMAGE PROCESSING AND MULTIMEDIA		
IP1	<u>Visual Object Tracking using Particle Clustering</u> <i>Harindra Wisnu Pradhana</i>	117

IP2	Selective Encryption of video MPEG use RSA Algorithm <i>Prati Hutari Gani, Maman Abdurohman</i>	122
IP3	Analytical Hierarchy Process for Land Suitability Analysis <i>Rahmat Sholeh, Fahrul Agus, and Heliza Rahmania Hatta</i>	127
IP4	Training Support for Pouring Task in Casting Process using Stereoscopic Video See-through Display - Presentation of Molten Metal Flow Simulation Based on Captured Task Motion <i>Kazuyo IWAMOTO, Hitoshi TOKUNAGA, Toshimitsu OKANE</i>	131
IP5	Feature Extraction and Classification of Heart Sound based on Autoregressive Power Spectral Density <i>Laurentius Kuncoro Probo Saputra, Hanung Adi Nugroho, Meirista Wulandari</i>	137
IP6	Smart-Meter based on current transient signal signature and constructive backpropagation method <i>Mat Syai'in, M.F. Adiatmoko, Isa Rachman, L. Subiyanto, Koko Hutoro, Ontoseno Penangsang, Adi Soeprijanto</i>	142
IP7	AUTOMATIC DOORSTOP SAFETY SYSTEM BASED ON IMAGE PROCESSING WITH WEBCAM AND SCANNER <i>Stanley Suryono Wibisono, Florentinus Budi Setiawan</i>	148
IP8	Palmprint Identification for User Verification based on Line Detection and Local Standard Deviation <i>Bagas Sakamulia Prakoso, Ivanna K. Timotius, Iwan Setyawan</i>	153
IP9	Cerebellar Model Articulation Controller (CMAC) for Sequential Images Coding <i>Muhamad Iradat Achmad, Hanung Adinugroho, Adhi Susanto</i>	158
IP10	A Comparative Study on Signature Recognition <i>Ignatia Dhian Estu Karisma Ratri, Hanung Adi Nugroho, Teguh Bharata Adji</i>	165
IP11	Study of Environmental Condition Using Wavelet Decomposition Based on Infrared Image <i>S. R. Sulistiyanti, M. Komarudin, L. Hakim, A. Yudamson</i>	170
IP12	Very High Throughput WLAN System for Ultra HD 4K Video Streaming <i>Wahyul Amien Syafei, Masayuki Kurosaki, and Hiroshi Ochi</i>	175
IP13	Iris Recognition Analysis Using Biorthogonal Wavelets Tranform for Feature Extraction <i>R. Rizal Isnanto</i>	181
INFORMATION AND COMPUTER TECHNOLOGIES		
ICT1	The Development of 3D Educational Game to Maximize Children's Memory <i>Dania Eridani, Paulus Insap Santosa</i>	187
ICT2	The Influence of Knowledge Management to Succesful Collaborative Design <i>Yani Rahmawati, Christiono Utomo</i>	192

ICT3	<u>Knowledge and Protocol on Collaborative Design Selection</u> <i>Christiono Utomo, Yani Rahmawati</i>	198
ICT4	<u>Mobile-Based Learning Design with Android Development Tools</u> <i>Okky Dwi Nurhayati, Kurniawan Teguh M</i>	202
ICT5	<u>A mobile diabetes educational system for Fasting Type 2 Diabetes in Saudi Arabia</u> <i>Mohammed Alotaibi</i>	207
ICT6	<u>Aggressive Web Application HoneyPot for Exposing Attacker's Identity</u> <i>Supeno Djanali, FX Arunanto, Baskoro Adi Pratomo, Abdurrazak Baihaqi, Hudan Studiawan, Ary Mazharuddin Shiddiqi</i>	211
ICT7	<u>Adjustment Levels for Intelligent Tutoring System using Modified Items Response Theory</u> <i>Ika Widiastuti, Nurul Zainal Fanani</i>	216
ICT8	<u>Smile Recognition System based on Lip Corners Identification</u> <i>Eduard Royce, Iwan Setyawan, Ivanna K. Timotius</i>	221
ICT9	<u>An Integrated Framework for Measuring Information System Success Considering the Impact of Culture in Indonesia</u> <i>Siti Mardiana</i>	225
ICT10	<u>Pre-Processing Optimization on Sound Detector Application AudiTion (Android Based Supporting Media for the Deaf)</u> <i>Gian Gautama, Imanuel Widjaja, Michael Aditya Sutiono, Jovan Anggara, Hugeng</i>	232
ICT11	<u>EVALUATION OF DISTRIBUTION NETWORK RELIABILITY INDEX USING LOOP RESTORATION SCHEME</u> <i>Daniar Fahmi, Abdillah F. I., IGN Satriyadi Hernanda, Dimas Anton Asfani</i>	238
ICT12	<u>Efficient Message Security Based Hyper Elliptic Curve Cryptosystem (HECC) for Mobile Instant Messenger</u> <i>Putra Wanda, Selo, Bimo Sunafri Hantono</i>	244
ICT13	<u>Application of Web-Based Information System in Production Process of Batik Industry Design Division</u> <i>Indah Soesanti</i>	249
ICT14	<u>Managing and Retrieval of Cultural Heritage Multimedia Collection Using Ontology</u> <i>Albaar Rubhasy, A.A.G. Yudhi Paramartha, Indra Budi, Zainal A. Hasibuan</i>	254
ICT15	<u>Individual Decision Model for Urban Regional Land Planning</u> <i>Agus Fahrul, Sumaryono, Subagyo Lambang, Ruchaemi Afif</i>	259
ICT16	<u>Enhancing Online Expert System Consultation Service with Short Message Service Interface</u> <i>Istiadi, Emma Budi Sulistiarini, Guntur Dharma Putra</i>	265
ICT17	<u>Mobile Nutrition Recommendation System For 0-2 Year Infant</u> <i>Ratih Nur Esti Anggraini, Siti Rochimah, Kessya Din Dalmi</i>	271

ICT18	<u>Comparison of Distance and Dissimilarity Measures for Clustering Data with Mix Attribute Types</u> <i>Hermawan Prasetyo, Ayu Purwarianti</i>	275
ICT19	<u>Determining E-commerce Adoption Level by SMEs in Indonesia Based on Customer-Oriented Benefits</u> <i>Evi Triandini, Daniel Siahaan, Arif Djunaidy</i>	280
ICT20	<u>Providing Information Sources Domain for Information Seeking Agent From Organizing Knowledge</u> <i>Istiadi, Lukito Edi Nugroho, Paulus Insap Santosa</i>	285
ICT21	<u>Decision Support System For Stock Trading Using Decision Tree Technical Analysis Indicators and Its Sensitivity Profitability Analysis</u> <i>F.X. Satriyo D. Nugroho, Teguh Bharata Adji, Silmi Fauziati</i>	290
ICT22	<u>Design Web Service Academic Information System Based Multiplatform</u> <i>Meta Lara Pandini, Zainal Arifin and Dyna Marisa Khairina</i>	296
ICT23	<u>Effects of VANET's Attributes on Network Performance</u> <i>Agung B. Prasetijo, Sami S. Alwakeel and Hesham A. Altwaijry</i>	302
ICT24	<u>Visualization of Condition Irrigation Building and Canal Using Web GIS Application</u> <i>Falahah, Defrin Karisia Ayuningtias</i>	308
ICT25	<u>Comparison of three back-propagation architectures for interactive animal names utterance learning</u> <i>Ajub Ajulian Zahra Macrina and Achmad Hidayatno</i>	314
ICT26	<u>WORK IN PROGRESS “ OPEN EDUCATION METRIC (OEM) : DEVELOPING WEB-BASED METRIC TO MEASURE OPEN EDUCATION SERVICES QUALITY</u> <i>Priyogi B., Nan Cenka B. A., Paramartha A.A.G.Y. &Rubhasy A.</i>	318

POWER SYSTEMS

PS1	<u>Design and Implementation of Solar Power as Battery Charger Using Incremental Conductance Current Control Method based on dsPIC30F4012</u> <i>Ahmad Musa, Leonardus H. Pratomo, Felix Y. Setiono</i>	323
PS2	<u>An Adaptive Neuro Fuzzy Inference System for Fault Detection in Transformers by Analyzing Dissolved Gases</u> <i>Ms. Alamuru Vani, Dr. Pessapaty Sree Rama Chandra Murthy</i>	327
PS3	<u>Optimal Power Flow based upon Genetic Algorithm deploying Optimum Mutation and Elitism</u> <i>M. Usman Aslam, Muhammad Usman Cheema, Muhammad Samran, Muhammad Bilal Cheema</i>	333
PS4	<u>Design Analysis and Optimization of Ground Grid Mesh of Extra High Voltage Substation Using an Intelligent Software</u> <i>M. Usman Aslam, Muhammad Usman Cheema, Muhammad Samran, Muhammad Bilal Cheema</i>	338

PS5	<u>Design and Simulation of Neural Network Predictive Controller Pitch-Angle Permanent Magnetic Synchronous Generator Wind Turbine Variable Pitch System</u> <i>Suyanto, Soedibyo, Aji Akbar Firdaus</i>	345
PS6	<u>Inverse Clarke Transformation based Control Method of a Three-Phase Inverter for PV-Grid Systems</u> <i>Slamet Riyadi</i>	350
PS7	<u>Control of a Single Phase Boost Inverter with the Combination of Proportional Integrator and Hysteresis Controller</u> <i>Felix Yustian Setiono</i>	355
PS8	<u>A Simple Three-phase Three-wire Voltage Disturbance Compensator</u> <i>Hanny H. Tumbelaka</i>	360
PS9	<u>Analysis of Protection Failure Effect and Relay Coordination on Reliability Index</u> <i>I.G.N Satriyadi Hernanda, Evril N. Kartinisari, Dimas Anton Asfani, Daniar Fahmi</i>	365
PS10	<u>Extreme Learning Machine Approach to Estimate Hourly Solar Radiation On Horizontal Surface (PV) in Surabaya –East Java</u> <i>Imam Abadi, Adi Soeprijanto, Ali Musyafa'</i>	370
PS11	<u>Maximum Power Point Tracking Control for Stand-Alone Photovoltaic System using Fuzzy Sliding Mode Control Maximum Power Point Tracking Control for Stand-Alone Photovoltaic System using Fuzzy Sliding Mode Control</u> <i>Antonius Rajagukguk, Mochamad Ashari, Dedet Candra Riawan</i>	375
PS12	<u>The Influence of Meteorological Parameters under Tropical Condition on Electricity Demand Characteristic: Indonesia Case Study</u> <i>Yusri Syam Akil, Syafaruddin, Tajuddin Waris, A. A. Halik Lateko</i>	381
PS13	<u>Optimal Distribution Network Reconfiguration with Penetration of Distributed Energy Resources</u> <i>Ramadoni Syahputra, Imam Robandi, Mochamad Ashari</i>	386
PS14	<u>Maximum Power Point Tracking Photovoltaic Using Root Finding Modified Bisection Algorithm</u> <i>Soedibyo, Ciptian Weriend Priananda, Muhammad Agil Haikal</i>	392
PS15	<u>Design of LLC Resonant Converter for Street Lamp Based On Photovoltaic Power Source</u> <i>Idreis Abdualgader , Eflita Yohana, Mochammad Facta</i>	398
PS16	<u>Power Loss Reduction Strategy of Distribution Network with Distributed Generator Integration</u> <i>Soedibyo, Mochamad Ashari, Ramadoni Syahputra</i>	402
PS17	<u>Double Dielectric Barrier Discharge Chamber for Ozone Generation</u> <i>Mochammad Facta, Hermawan, Karnoto, Zainal Salam, Zolkafle Buntat</i>	407
PS18	<u>Leakage Current Characteristics at Different Shed of Epoxy Resin Insulator under Rain Contaminants</u> <i>Abdul Syakur, Hermawan</i>	411

PS19	<u>Transformer monitoring using harmonic current based on wavelet transformation and probabilistic neural network (PNN)</u> <i>Imam Wahyudi F., Wisnu Kuntjoro Adi, Ardyono Priyadi, Margo Pujiantara, Mauridhi Hery P</i>	417
------	---	-----

TELECOMUNICATIONS

TE1	<u>Data Rate of Connections Versus Packet Delivery of Wireless Mesh Network with Hybrid Wireless Mesh Protocol and Optimized Link State Routing Protocol</u> <i>Alexander William Setiawan Putra, Antonius Suhartomo</i>	422
TE2	<u>Empirical Studies of Wireless Sensor Network Energy Consumption for Designing RF Energy Harvesting</u> <i>Eva Yovita Dwi Utami, Deddy Susilo, Budihardja Murtianta</i>	427
TE3	<u>Modulation Performance in Wireless Avionics Intra Communications (WAIC)</u> <i>Muhammad Suryanegara, Naufan Raharya</i>	432
TE4	<u>Implementation and Performance Analysis of Alamouti Algorithm for MIMO 2^t—2 Using Wireless Open-Access Research Platform (WARP)</u> <i>Rizadi Sasmita Darwis, Suwadi, Wirawan, Endroyono, Titiiek Suryani, Prasetyono Hari Mukti</i>	436
TE5	<u>Period Information Deviation on the Segmental Sinusoidal Model</u> <i>Florentinus Budi Setiawan</i>	441
TE6	<u>A Compact Dual-band Antenna Design using Meander-line Slots for WiMAX Application in Indonesia</u> <i>Prasetyono Hari Mukti, Eko Setijadi, Nancy Ardelina</i>	445
TE7	<u>Design and Analysis of Dualband J-Pole Antenna with Variation in “T” Shape for Transceiver Radio Communication at VHF and UHF Band</u> <i>Yoga Krismawardana, Yuli Christyono, Munawar A. Riyadi</i>	449
TE8	<u>Low Cost Implementation for Synchronization in Distributed Multi Antenna Using USRP/GNU-Radio</u> <i>Savitri Galih, Marc Hoffmann, Thomas Kaiser</i>	455
TE9	<u>Development of the First Indonesian S-Band Radar</u> <i>Andrian Andaya Lestari, Oktanto Dedi Winarko, Herlinda Serliningtyas, Deni Yulian</i>	459
	<u>Back Cover</u>	

AUTHOR INDEX

Abadi, Imam	370	Galih, Savitri	455
Abdillah F. I.	238	Gani, Prati Hutari	122
Abdualgader, Dreis	398	Gautama, Gian	232
Abdurohman, Maman	122	Gemini, Vipin	81
Abraha, Kamsul	77	Hafizh, Idham	19
Abuelenin, Sherif M.	61	Haikal, Muhammad Agil	392
Achmad, Muhamad Iradat	158	Hakim, L.	170
Adi, Wisnu Kuntjoro	417	Hantono, Bimo Sunafri	244
Adiatmoko, M.F.	142	Hasibuan, Zainal A.	254
Adiono, Trio	19	Hatta, Heliza Rahmania	127
Adji, Teguh Bharata	165,290	Hendarto, Hugo Adeodatus	33, 39
Afif, Ruchaemi	259	Hermawan	407, 411
Agus, Fahrul	127	Hernanda, IGN Satriyadi	238, 365
Akil, Yusri Syam	381	Hery P, Mauridhi	417
Akrom, Afdhal	103	Hidayat, S.S.	28
Alotaibi, Mohammed	207	Hidayat, Sidiq Syamsul	24
Altwaijry, Hesham A.	302	Hidayatno, Achmad	314
Alwakeel, Sami S.	302	Hoffmann, Marc	455
Anggara, Jovan	232	Hugeng	232
Anggraini, Ratih Nur Esti	271	Hutoro, Koko	142
Anif, M.	28	Ilham, Julian	44
Anif, Muhammad	24	Isnanto, R. Rizal	181
Ardelina, Nancy	445	Istiadi	265, 285
Ardyanto, Aditya Ferry	19	Iswanto	87
Arifin, Zainal	296	Iwamoto, Kazuyo	131
Asfani, Dimas Anton	238, 365	Kaiser, Thomas	455
Ashari, Mochamad	375,386,402	Karnoto	407
Aslam, M. Usman	333	Kartinisari, Evril N.	365
Ayuningtias, Defrin Karisia	308	Khairina, Dyna Marisa	296
Budi, Indra	254	Koesuma, Sorja	28
Buntat, Zolkafle	407	Komarudin, M.	170
Cahyadi, Adha Imam	66, 87	Krismawardana, Yoga	449
Cheema, Muhammad Bilal	333,338	Kurnianingsih	24, 97
Cheema, Muhammad Usman	333	Kurosaki, Masayuki	175
Christyono, Yuli	449	Lambang, Subagyo	259
Chung, Wan-Young	44	Lestari, Andrian Andaya	459
Dalmi, Kessya Din	271	Macrina, Ajub Ajulian Zahra	314
Daoud, Ahmad A.	61	Mardiana, Siti	225
Darwis, Rizadi Sasmita	436	Mukti, Prasetyono Hari	436,445
Djaelani, Elan	50	Munadi	33,39
Djunaidy, Arif	280	Munandar, Devi	72
El-Rabaie, El-Sayed M.	14	Murthy, Pessapaty S.R Chandra	327
Elgreatly, Ahmed Lutfi	14	Murtianta, Budihardja	427
Endroyono	436	Musa, Ahmad	323
Eridani, Dania	187	Musyafa', Ali	370
Facta, Mochammad	398, 407	Nan Cenka, B. A.	318
Fahmi, Daniar	238, 365	Nugroho, F.X. Satriyo D.	290
Fahrul, Agus	259	Nugroho, Hanung Adi	66, 137, 158, 165
Falahah	308	Nugroho, Lukito Edi	97,285
Fanani, Nurul Zainal	216	Nurhayati, Oky Dwi	202
Faris, Muhammad	66,87	Nurrahmi, Siti	77
Fauziati, Silmi	290	Ochi, Hiroshi	175
Firdaus, Aji Akbar	345	Okane, Toshimitsu	131

Pandini, Meta Lara	296	Soesanti, Indah	249
Paramartha A.A.G. Y.	318	Studiawan, Hudan	211
Paramartha, A.A.G. Yudhi	254	Subiyanto, L.	142
Penangsang, Ontoseno	142	Sugiarto, Bambang	50
Pradhana, Harindra Wisnu	117	Suharjono, A.	28
Prakoso, Bagas Sakamulia	153	Suharjono, Amin	24
Pramudita, Kevin Eka	56	Suharjono, Lateko	381
Prasetijo, Agung B.	302	Suhartomo, Antonius	422
Prasetyo, Hermawan	275	Sulistiarini, Emma Budi	265
Prasetyo, Totok	24	Sulistiyanti, S. R.	170
Pratomo, Leonardus H.	323	Sumaryono	259
Priananda, Ciptian Wieried	392	Supriyo, B.	28
Priyadi, Ardyono	417	Suryanegara, Muhammad	432
Priyogi B.	318	Suryani, Titiek	436
Pujiantara, Margo	417	Susanto, Adhi	113, 158
Purwarianti, Ayu	275	Susilo, Deddy	427
Putra, Alexander W Setiawan	422	Sutiono, Michael Aditya	232
Putra, Guntur Dharma	265	Suwadi	436
Putra, Septian Gilang Permana	19	Suyanto	345
Rachman, Isa	142	Syafaruddin	381
Raharja , Nia Maharani	87	Syafei, Wahyul Amien	175
Raharya, Naufan	432	Syafraditya, Tierta	109
Rahmawati, Yani	192,198	Syahputra, Ramadoni	386,402
Rajagukguk, Antonius	375	Syai'in, Mat	142
Rakhman, Arkham Zahri	97	Syakur, Abdul	411
Ratri, Ignatia Dhian Estu Karisma	165	Syamsi, Djohar	72
Riawan, Dedet Candra	375	Teguh M, Kurniawan	202
Riyadi, Munawar A.	449	Timotius, Ivanna K.	153, 221
Riyadi, Slamet	350	Tjokronagoro, Maesadjie	113
Robandi, Imam	386	Tokunaga, Hitoshi	131
Rochimah, Siti	271	Triandini, Evi	280
Royce, Eduard	221	Triyana, Kuwat	77
Rubhasy A.	318	Tumbelaka, Hanny H.	360
Rubhasy, Albaar	254	Ubaya, Huda	103
Sakti, Indra	91	Umiati, Ngurah Ayu Ketut	77
Salam, Zainal	407	Utami, Eva Yovita Dwi	427
Samran	338	Utomo, Christiono	192, 198
Samran, Muhammad	333	Vani, Alamuru	327
Santosa, Paulus Insap	187,285	Wahyudi F., Imam	417
Santoso, Imam	113	Wanda, Putra	244
Saputra, Laurentius Kuncoro Probo	137	Waris, Tajuddin	381
Selo	244	Wibisono, Gunawan	109
Serliningtyas, Herlinda	459	Wibisono, Stanley Suryono	148
Setiawan, F. Budi	56	Widiastuti, Ika	216
Setiawan, Florentinus Budi	148, 441	Widjaja, Imanuel	232
Setiawan, Joga Dharma	33, 39	Widodo, Thomas Sri	113
Setijadi, Eko	445	Widyawan	97
Setiono, Felix Y.	323, 355	Winarko, Oktanto Dedi	459
Setyawan, Iwan	153, 221	Wirawan	436
Shaaban, Ahmed A.	14, 61	Wulandari, Meirista	137
Shiddiqi, Ary Mazharuddin	211	Yohana, Eflita	398
Sholeh, Rahmat	127	Yudamson, A.	170
Siahaan, Daniel	280	Yulian, Deni	459
Siswanto	56		
Soedibyoy	345,392,402		
Soeprijanto, Adi	142, 370		

A Simple Three-phase Three-wire Voltage Disturbance Compensator

Hanny H. Tumbelaka,

Member, IEEE

Electrical Engineering Department, Petra Christian University

Surabaya, Indonesia

E-mail: tumbekh@petra.ac.id

Abstract – The two-leg four-switch VC-VSI with a direct load voltage controller has been developed as a three-phase multi-functional voltage disturbance compensator for a three-phase three-wire system. By controlling only two legs (two phases) of the inverter, the third leg automatically generates the correct third voltage. The VC-VSI is connected in series between the PCC and loads by three single-phase matching transformers. The transformer primary windings are connected in delta. The VC-VSI operates to directly control the load voltage rather than its output voltage using a simple PI controller. The VC-VSI is able to produce automatically a three-phase compensation voltage so that the load voltage is sinusoidal, symmetrical and constant at a nominal value. Computer simulation verifies that the VC-VSI is able to perform well as a voltage disturbance compensator, although there is still an insignificant deviation (around 1%). The THD of the load voltage reduces to 1.4%.

Keywords – Voltage sag/swell, Harmonic Voltage, Unbalanced Voltage, Three-phase Two-leg Inverter

I. INTRODUCTION

A high quality of an electric source is important for an electric equipment to operate properly. A good three-phase AC voltage supply should be constant, sinusoidal and symmetrical. However, a real AC voltage supply experiences disturbances such as voltage sag and swell, harmonic distortion and unsymmetrical. The quality of the AC voltage supply decreases. Consequently, the electric equipment could be broken down.

There are many ways to deal with the voltage problems. One of the solutions is to install a superior electric equipment that is reliable and tolerant to disturbance. The equipment would be expensive because it is not easy to produce it. Another possible solution is to mitigate the voltage disturbances by installing a voltage compensator at the point of common coupling (PCC). The equipment compensates for disturbances so that electric loads will receive a high quality AC voltage. The examples of a voltage compensator are a series active power-filter (SAPF) and a dynamic voltage restorer (DVR), which are made of power electronic devices

SAPF is generally used to reduce voltage harmonics from an electric source. The filter consists of power electronic

devices (commonly six transistors as switches) to form a voltage source inverter (VSI). The VSI is connected in series between the distorted source and loads using a matching transformer. Then the VSI injects an equal-but-opposite voltage harmonics according to its reference harmonic voltage [1,2]. As a result, the terminal voltage of loads will receive a sinusoidal voltage waveform. Losses due to voltage harmonics will be minimized. SAPF could also compensate for voltage harmonics generated by a non-linear load. In this case, the filter is inserted between the load and PCC so that other loads connected at PCC will receive a clean voltage.

DVR is mostly used to mitigate voltage sag and swell. In voltage sag or swell, the voltage of the power system fluctuates exceeding a tolerable working voltage of equipment in a period of 0.5 cycles to a few seconds. Voltage sag/swell usually happens when a load with high power is on/off or a fault occurs/disappears on the power system. Similar to SAPF, DVR is an inverter (VSI), which is connected in series between the PCC and loads using a matching transformer [3,4,5]. DVR compensates for a voltage drop/rise (ΔV) according to voltage deviations detected at the PCC so that the load voltage will be maintained at a nominal voltage.

To improve the mitigation strategy, it is a challenge to eliminate voltage harmonic and voltage sag/swell as well as voltage unbalance with one multi-functional compensator rather than applying one compensator for one specific voltage disturbance. The simultaneous compensation is possible because voltage disturbances need a series type of a compensator. However, the problem is to create an inclusive control strategy especially to generate a single reference voltage for handling several types of voltage disturbances. Therefore, a different approach is chosen, which is directly controlling the load voltage.

Moreover, since three-phase loads such as fixed- or variable-speed induction motors are the most common equipment in industries, the application of the compensator will focus on a three-phase three-wire system (a delta system). Therefore, it is a challenge to use a four-switch VSI as the main power circuit. Reducing the number of switches may reduce the cost and simplify the controller.

Hence, this paper proposes a simple and low cost three-phase voltage disturbance compensator for protection of sensitive or critical loads from voltage harmonics and voltage sag/swell as well as voltage unbalance. The expected outcome would be a constant, sinusoidal and symmetrical load voltage so that the electric equipment will operate properly within a permissible working voltage.

II. VOLTAGE COMPENSATOR CONFIGURATION

Similar to SAPF and DVR, the proposed three-phase voltage compensator is comprised of a Voltage Source Inverter (VSI) with an energy storage element or a DC source (e.g. battery) at the DC bus and a simple LC high-pass filter at the AC side to filter out switching harmonics [4,5]. The VSI is supported by a simple controller for switching transistors.

Commonly, the VSI consists of six switches (i.e. six IGBTs with anti-parallel Diodes). However, for a three-phase three-wire configuration, the number of switches can be reduced to four switches in order to reduce the cost and to simplify the controller. As a result, the power circuit of the VSI becomes two legs of switches (phase A and B) and a split capacitor in the third leg (phase C) [6]. The two-leg four-switch VSI is shown in figure 1. By controlling the two legs, the output voltage of the third leg (phase C) will be generated instantaneously following the voltage summation rule for a three-phase system:

$$V_A + V_B + V_C = 0 \tag{1}$$

$$V_{AC} + V_{BA} + V_{CB} = 0 \tag{2}$$

The VSI is connected in series between the source and loads by three single-phase matching transformers. The AC side (output) of the VSI is connected to the primary side of matching transformers. The secondary side of the transformers is inserted into an electrical network between the PCC and loads. For three-phase three-wire system, the transformer primary-windings are connected in delta (Fig. 2).

III. COMPENSATION PROCESS

For voltage compensation, the VSI is operated as a voltage-controlled VSI (VC-VSI). A controller regulates the switches of the VC-VSI so that the VSI generates a proper output voltage for eliminating the voltage disturbances. To simplify the process, the VC-VSI directly controls the load voltage ($V_{Load, Ph-Ph}$) rather than its output voltage (V_{OUT}). In this case, the load voltage is sensed and directly compared to a symmetrical sinusoidal reference signal ($V_{REF, Ph-Ph}$).

For the two-leg VSI, two voltage sensors detect two phase-phase load voltages (V_{AC} and V_{BA}). V_{AC} and V_{BA} are compared to the same phase of the reference voltages to generate error signals. The magnitude of the reference voltage should be constant at a normal value (e.g 380V_{rms}). Its phase angle should be synchronized to the fundamental component of PCC

voltage (using a phase-lock-loop – PLL circuit) so that a phase jump will not occur during compensation [3,5].

Then, the error signals are modulated by a triangular carrier signal ($f = 20\text{kHz}$) to generate Pulse Width Modulation (PWM) for controlling the switching operation of four IGBTs as described in figure 3. A simple PI controller is employed to make the error signal become zero. As a result, the load voltage equals to the reference voltage. A simple and direct controller for the VC-VSI can be seen in figure 3. A simple LC high-pass filter is used to eliminate high frequency ripples so that V_{Load} will be the same as V_{REF} .

Hence, by directly controlling the load voltage, the VC-VSI automatically generates an output voltage as a compensation voltage.

$$V_{PCC} - V_{Load} = V_{Compensation} \tag{3}$$

$$V_{Compensation} = V_{OUT} \tag{4}$$

$$V_{Load} = V_{REF} \tag{5}$$

The output (compensation) voltage will be injected to the electrical network to eliminate voltage disturbances by using matching transformers. The winding ratio of the matching transformer is selected according to a working voltage of the system and the VC-VSI.

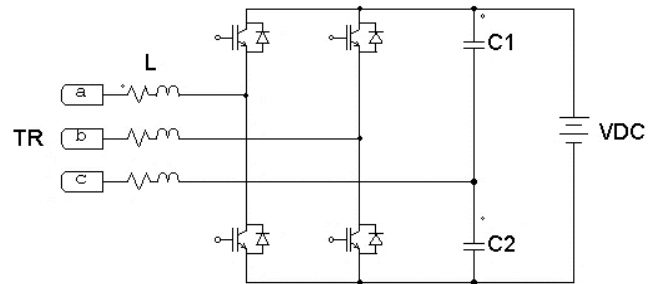

Fig. 1. Two-leg four-switch VC-VSI

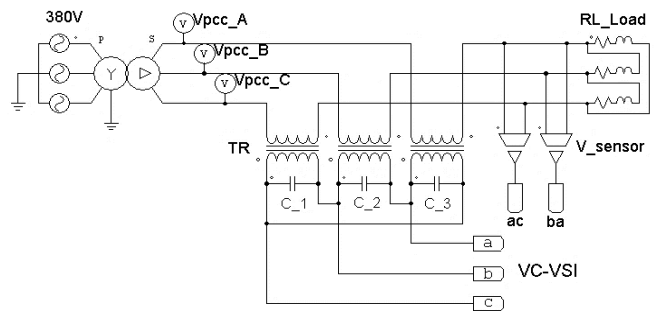

Fig. 2. Voltage Disturbance Compensator Configuration

Moreover, DC-bus capacitor voltages of the split capacitor (C1 and C2) in the third leg could be unbalance, especially at the initial condition. To minimize the capacitor voltage unbalance, a quantity (D_{VC}) proportional to the capacitor

voltage difference ($D_{VC} = k \Delta V_C$) is added to the error signals [6]. This method is useful to improve the performance of the phase C output voltage.

The compensation process will be successful when the load voltage is the same as the reference voltage. The VC-VSI injects the compensation voltage as needed through matching transformers.

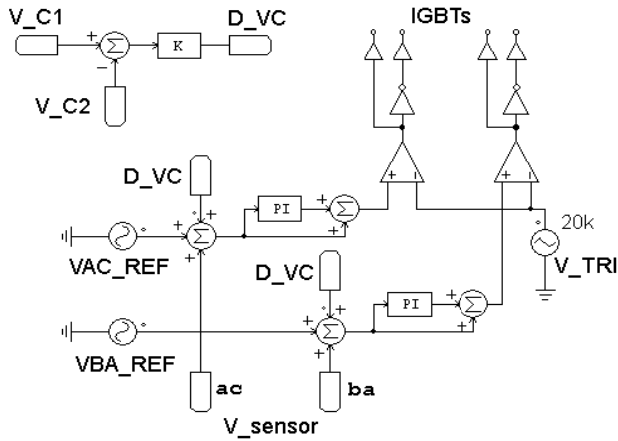

Fig. 3. A Simple and Direct Load Voltage Controller

IV. SIMULATION AND DISCUSSION

A. Simulation Parameter

To verify the concept of the three-phase three-wire voltage disturbance compensator, the proposed circuits (Fig. 1 to Fig. 3) have been built and simulated using PSIM® simulator. Then, the performance of the circuits will be evaluated.

The compensator is working on a three-phase three-wire system. The source voltage (phase-phase) has a fundamental component of $380V_{rms}$ ($f_1 = 50\text{Hz}$) and a fifth harmonic. The load is a three-phase RL load and connected in delta. Without compensation and additional voltage disturbances, the three-phase load voltage, which is the same as the voltage at the PCC, and the three-phase load current can be seen in figure 4. Total Harmonic Distortion (THD) of $V_{PCC} = 6.2\%$.

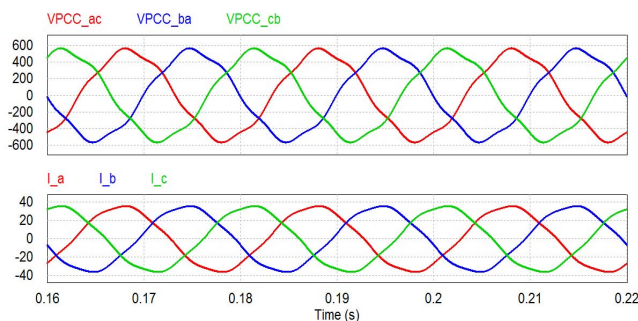

Fig. 4. The three-phase PCC voltage (= load voltage) (top) and load current (bottom) without compensation

At the DC side of the VC-VSI, there is a DC source of 575V. The split capacitor $C1 = C2 = 10\text{mF}$. The AC side has a high-pass filter $L = 0.14\text{mH}$ and $C = 100\mu\text{F}$. Constants of the PI controller, $K_P = 10$, $T_i = 0.45$. The frequency of a triangular carrier signal = 20kHz. Winding ratio of the matching transformer = 1. Winding connection: delta/open-wye

B. Simulation Results

When there is no additional voltage disturbance, the voltage compensator is working as a harmonic filter to eliminate the harmonic voltage at the load from the source. As a result, figure 5 shows the clean load voltage and current. The three-phase load voltage is sinusoidal, symmetrical and constant around $377V_{rms}$ identical to the reference voltage. THD of V_{Load} decreases significantly to 1.3%. The load voltage is also in-phase with the PCC voltage. Figure 6 shows the compensation voltage at the secondary side of the matching transformers generated by the VC-VSI, which is the same as the harmonic voltage produced by the source.

Thus, by controlling only two legs of the inverter, the third leg automatically produces the proper third voltage (phase C). Moreover, by directly controlling the load voltage, automatically the VC-VSI is able to generate a three-phase anti-harmonic voltage and to eliminate the distortion at the load through the matching transformers.

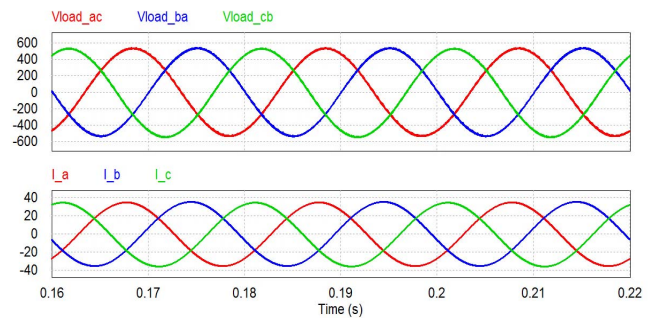

Fig. 5. The load voltage (top) and the load current (bottom) after harmonic compensation

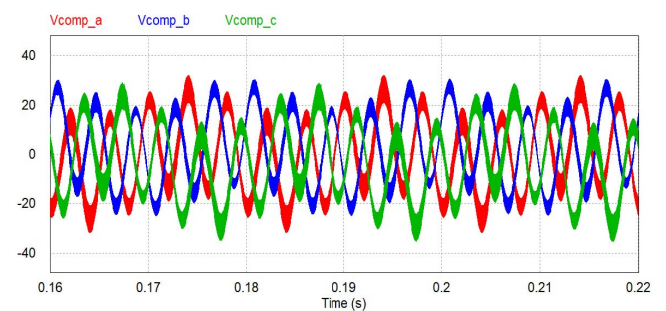

Fig. 6. Compensation for harmonic voltage

Another case, when there is a sudden voltage drop at the PCC, the voltage compensator should be able to operate as both a harmonic filter and a voltage restorer. The voltage drop could be balanced or unbalanced. The unbalanced voltage drop could be single phase or two phases.

The three-phase balanced voltage drop can be seen in figure 7. In this case, the three-phase PCC voltage decreases to 278V_{rms}. Similar to the previous case, by controlling the load voltage to be sinusoidal, symmetrical and constant at a normal value, the VC-VSI is able to produce the compensation voltage (Fig. 8) so that the load voltage would stay at a normal value and balance. The rms value of the load voltage are as follows: $V_{AC} = 370V$, $V_{BA} = 379V$, $V_{CB} = 368V$.

The performance of the load voltage can be improved by balancing the split-capacitor voltage on the third leg of the VSI. By adjusting the value of $k = -0.2$, the rms value of the load voltage becomes as follows: $V_{AC} = 375V$, $V_{BA} = 379V$, $V_{CB} = 376V$. There is still a voltage drop (ΔV_{max} 1.3%) and a voltage unbalance (1.05%). But, the deviation is small and considered insignificant. The harmonic voltage is also eliminated (THD $V_{Load} = 1.4\%$). The value of $k = -0.2$ will be applied to all cases of voltage disturbances.

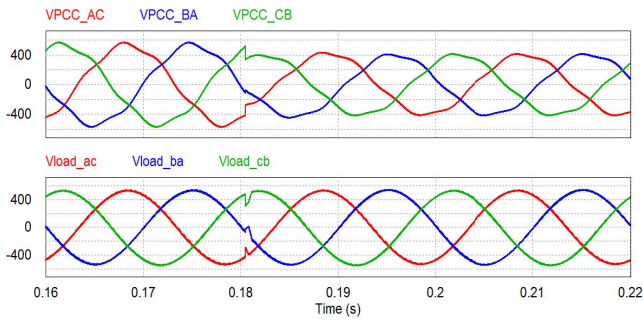

Fig. 7. The PCC voltage (top) and the load voltage (bottom) after compensation for a balanced fault

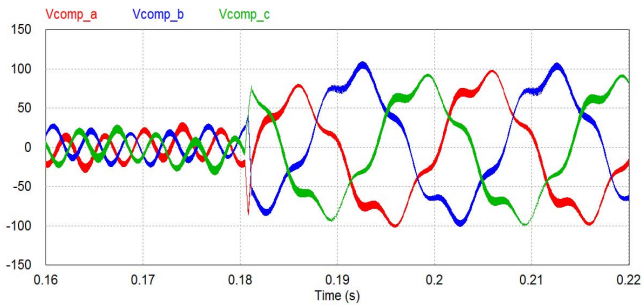

Fig. 8. Compensation for harmonic and voltage drop due to a balanced fault

From figure 7, it can be seen at $t = 0.18ms$, when a fault occurs, there is a notch on the load voltage waveforms. It seems that the response of a PI controller with triangular modulation is not quick enough for the sudden voltage drop so that the compensation is not successful. However, the process

takes only 0.6ms, which is considered insignificant. For the fast response, a sliding mode type of controllers such as a hysteresis or a ramp-time controller [5,7] might be an option. The sliding mode controller may also be able to enhance the steady state performance of a direct load voltage control system.

To prove the ability of the voltage disturbance compensator to handle the unbalanced voltage drop is described in figure 9 and 10. In this case, the two-phase unbalanced voltage drop due to a phase-to-phase fault is selected for a three-phase three-wire system.

Figure 9 shows that, after compensation, the load voltage becomes sinusoidal, symmetrical and constant. $V_{AC} = 375V$, $V_{BA} = 378V$, $V_{CB} = 376V$. The performance of the controller is the same as the previous case. There is still a voltage drop (ΔV_{max} 1.3%) and a voltage unbalance (0.8%). But, the deviation is small and considered insignificant. The harmonic voltage is also eliminated (THD $V_{Load} = 1.4\%$). The VC-VSI generates the compensation voltage (Fig. 10) to maintain the load voltage at a normal value and to eliminate the harmonics. Compared to figure 8, it is proved that the VC-VSI is automatically able to generate a different compensation voltage for a different disturbance voltage as long as its operation satisfies (1) to (5).

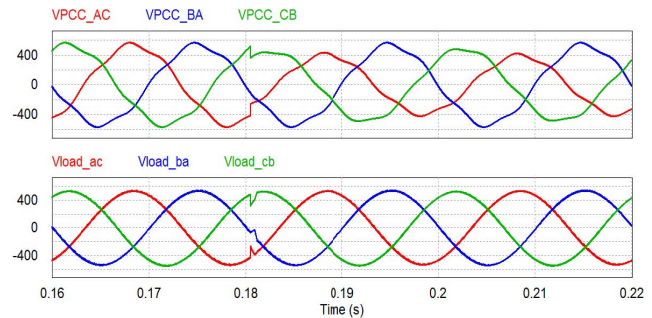

Fig. 9. The PCC voltage (top) and the load voltage (bottom) after compensation for an unbalanced (phase-to-phase) fault

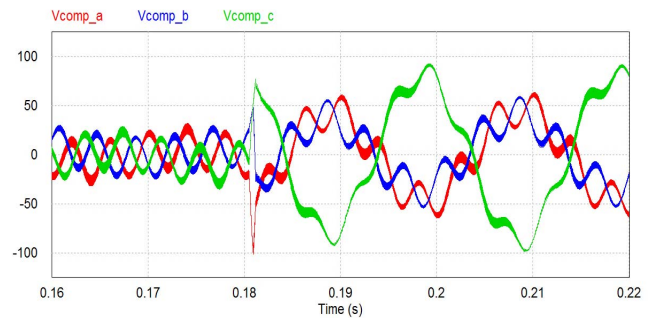

Fig. 10. Compensation for harmonic and voltage drop due to an unbalanced (phase-to-phase) fault.

The voltage compensator is also able to compensate for the voltage rise, although this phenomenon is less common than

the voltage sag. In this case, a balanced voltage rise is selected for a three-phase three-wire system.

Figure 11 shows that the three-phase PCC voltage increases from a normal voltage at $t = 0.18\text{ms}$ to become 443V_{rms} . Then, automatically the VC-VSI generates the compensation voltage (Fig. 12) to subtract the voltage rise. The load voltage is kept at a normal value. The controller performs well to handle the voltage rise. In this case, its transient response is better than the response for handling the voltage sag. The load voltage becomes sinusoidal, symmetrical and constant. $V_{AC} = 377\text{V}_{\text{rms}}$, $V_{BA} = 376\text{V}_{\text{rms}}$, $V_{CB} = 378\text{V}_{\text{rms}}$. The harmonic voltage is eliminated as well (THD $V_{\text{Load}} = 1.4\%$).

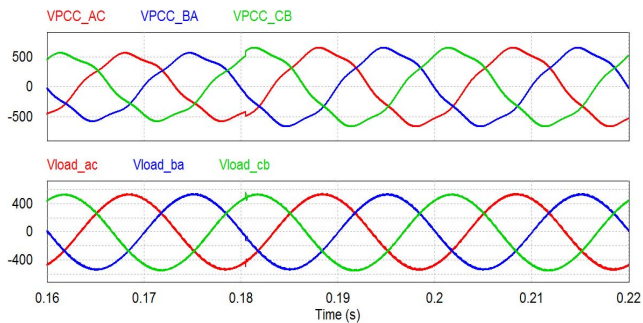

Fig. 11. The PCC voltage (top) and the load voltage (bottom) after compensation for a voltage rise

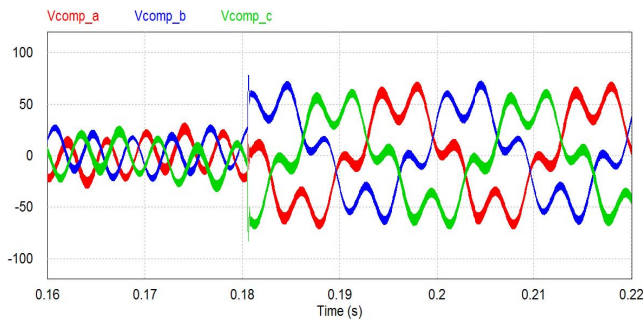

Fig. 12. Compensation for harmonic and voltage rise

V. CONCLUSION

The two-leg four-switch VSI has been proven to be used as a three-phase multi-functional voltage disturbance compensator for a three-phase three-wire system. For voltage compensation, the VSI is operated as a voltage-controlled VSI (VC-VSI). A controller regulates the VC-VSI to generate a proper output voltage for eliminating the voltage disturbances. The VC-VSI is connected in series between the PCC and loads by three single-phase matching transformers. The transformer primary windings are connected in delta.

By controlling only two legs of the inverter, the third leg automatically generates the correct third voltage (phase C) so

that the VC-VSI produces a complete three-phase compensation voltage. Moreover, by directly controlling the load voltage rather than its output voltage, the VC-VSI is automatically able to generate the compensation voltage. As a result, the load voltage is sinusoidal, symmetrical and constant at a normal value.

Computer simulation verifies that the VC-VSI is able to compensate harmonic voltage and balanced/unbalanced voltage sag/swell. The performance of the VC-VSI supported by a simple PI controller is satisfied. Although there is still a voltage drop and a voltage unbalance, but the deviation is small (around 1%) and considered insignificant. The THD of the load voltage reduces to 1.4%.

REFERENCES

- [1] Bhim Singh, K. Al-Haddad, and A. Chandra, *A Review of Active Filters for Power Quality Improvement*. IEEE Trans. On Industrial Electronics, Vol. 46, No. 5, October 1999, pp.960 - 971.
- [2] Juan W. Dixon, G. Venegas, and L.A. Mor'an. *A Series Active Power Filter Based on a Sinusoidal Current-Controlled Voltage-Source Inverter*, IEEE Trans. On Industrial Electronics, Vol. 44, No. 5, October 1997, pp 612 - 620
- [3] Tarek I. El-Shennawy et.al., *A Dynamic Voltage Restorer for Voltage Sag Mitigation in a Refinery with Induction Motors Loads*, American J. of Engineering and Applied Sciences, 3 (1): 144-151, 2010
- [4] John G. Nielsen and Frede Blaabjerg, *A Detailed Comparison of System Topologies for Dynamic Voltage Restorers*, IEEE Trans. On Industry Applications, Vol. 41, No. 5, September 2005, pp. 1272 -1280
- [5] H. Ezojie et.al., *Simulation of Dynamic Voltage Restorer Using Hysteresis Voltage Control*, European Journal of Scientific Research, Vol.27 No.1, 2009, pp.152-166
- [6] Huang-Jen Chiu et.al., *Three-Phase Active Power Filter for Power Quality Compensation*, IEEE PEDS, 2003, pp. 1540 - 1542
- [7] Tumbelaka, H.H, Borle, L.J., *Harmonic Mitigation Using a Polarized Ramp-time Current-Controlled Inverter*, TELKOMNIKA, vol.8, no.3, 2010



2014

The 1st International Conference
on Information Technology,
Computer, and Electrical Engineering

ICITACEE



**DEPARTMENT OF ELECTRICAL ENGINEERING
DIPONEGORO UNIVERSITY**
Jalan Prof. Sudarto, SH, Tembalang
Semarang, 50275, Indonesia

