



City Research Online

City, University of London Institutional Repository

Citation: Liu, Y., Wang, J., Li, Z., Wang, J., Ning, Y., Liu, T. and Grattan, K. T. V. ORCID: 0000-0003-2250-3832 (2018). Enhanced Raman Detection System based on a Hollow-core Fiber Probe design. IEEE Sensors Journal, doi: 10.1109/JSEN.2018.2877967

This is the accepted version of the paper.

This version of the publication may differ from the final published version.

Permanent repository link: <http://openaccess.city.ac.uk/21095/>

Link to published version: <http://dx.doi.org/10.1109/JSEN.2018.2877967>

Copyright and reuse: City Research Online aims to make research outputs of City, University of London available to a wider audience. Copyright and Moral Rights remain with the author(s) and/or copyright holders. URLs from City Research Online may be freely distributed and linked to.

City Research Online:

<http://openaccess.city.ac.uk/>

publications@city.ac.uk

Enhanced Raman Detection System based on a Hollow-core Fiber Probe design

Yuan Liu, Jinyu Wang, Zhen Li, Jiqiang Wang, Yanong Ning, Tongyu Liu, and Kenneth T.V. Grattan

Abstract—In this paper, an enhanced Raman-based detection system that employs a hollow-core fiber as the basis of an innovative probe design to allow liquid micro-samples to be analyzed has been developed and its performance evaluated. The hollow-core fiber is used both to transmit the light signal used to excite the sample and to collect the Raman scattering signal received from the micro-sample under analysis. In order to maximize the performance of the system, various parameters have been studied experimentally, including the diameter and the length of the hollow-core fiber used and the height of the liquid sample in the probe. The aim has been optimizing both as a means to enhance the Raman scattering signal received from the liquid sample. As a result, a Raman-based detection probe using a reflector approach was developed and evaluated, this design enabling a greater area for interaction with the sample to be formed and to concentrate the excitation light into it. This then increases the efficiency of the light-liquid interaction and improves the collection efficiently of the forward Raman scattering light signal. With the use of this design, the detected Raman scattering signal was increased by a factor of 10^3 – 10^4 over what otherwise would be achieved. A key feature is that with the use of a hollow-core fiber to collect the liquid sample, only a very small volume is needed, making this well suited to practical applications where limited amounts of material are available e.g. biofluids or high value liquids. The system designed and evaluated thus provides the basis of an effective all-fiber Raman-based detection system, capable of being incorporated into portable analysis equipment for rapid detection and in-the-field use.

Index Terms—Hollow-core fiber (HF), Raman detection probe, enhanced structure, small liquid sample measuring method

I. INTRODUCTION

RAMAN spectroscopy is a well-known molecular structure characterization technology based on the Raman scattering phenomenon which can be used to identify the chemical functional groups of various molecules [1], [2]. Since in traditional use, Raman scattering signals are weak, demonstrating only a small fraction of the Rayleigh scattering light intensity, applications are limited to situations where light intensities are high, samples are large and sensitive detection is

used. In order to improve the signal intensity in Raman spectroscopy, enhancement techniques such as Surface Enhanced Raman Spectroscopy (SERS), Resonance Raman Spectroscopy (RRS), and Raman microscopy have been developed and are widely used [3], [4], [5]. In recent years, optical fiber-based techniques have been employed with Raman spectroscopy as probes then can be made very small, and potentially only a smaller volume of sample only is needed. This makes on-line detection methods much easier to use, especially for in-the-field measurements and when sample sizes are limited [6], [7]. Therefore, combining advanced Raman enhancement technology and specialty fiber or using specially-designed enhancement structures for fiber-optic-based trace samples Raman detection has the potential to allow more compact and versatile instruments to be designed [8]. Amongst the specialty fibers available, hollow-core fiber (HF), which is an optical waveguide with its central core filled with air, has significant potential. The design of the probe system can be such that when a hollow-core fiber is used, the liquid sample under analysis can be sucked into the core itself, allowing the fiber to be both light guide and liquid micro-cuvette. At the same time, the excitation light guided by the hollow-core will experience multiple reflections within the liquid micro-sample in the core which therefore will increase the effective length of the excitation light-sample interaction. This additionally enhances the intensity of the excited Raman scatter light signal created and guided by the fiber, thereby increasing the intensity of the spontaneous Raman spectrum that can be detected. Li et al [9], in work carried out in the 1990s, used a liquid core optical fiber to develop a new experimental method for trace sample analysis, thereby taking advantage of the small liquid volumes that could be used. With such an approach, the intensity of the Raman spectra intensity was enhanced by 10^3 . However, the method reported was relative complex to implement for actual sample measurement applications. Gu et al [10] reported the first quantitative Raman detection of glucose in the physiological concentration range (0–25 mM) with a low laser power (2 mW), and an extremely small sampling volume (~50 nL) using a liquid-filled photonic crystal fiber (PCF) probe.

This work was partly supported by the Natural Science Foundation of Shandong Province (No. 2016ZRC01104), the National Key Research and Development Programs of China (2017YFC0804403 and 2016YFC0801405). The support of the Royal Academy of Engineering and the George Daniels Educational Trust is greatly appreciated (*Corresponding author: Tongyu Liu and Yuan. Liu*).

Y. Liu, J. Y. Wang, Z. Li, J. Q. Wang, Y. N. Ning, and T. Y. Liu are with the Laser Institute, Qilu University of technology (Shandong Academy of

Sciences), Jinan, China (e-mail: yuan.liu@sdllaser.cn; jinyu.wang@sdllaser.cn; zhen.li@sdllaser.cn; jiqiang.wang@sdllaser.cn; yanong_ning@hotmail.com; tongyu.liu@vip.iss-ms.com).

Kenneth T.V. Grattan is with the School of Mathematics, Computer Science & Engineering, City University of London, London, United Kingdom, (e-mail: k.t.v.grattan@city.ac.uk).

However, the absorption and the propagation loss of PCF was large, but he pointed out the PCF probe can be integrated with SERS techniques to further improve the sensitivity. In 2016, Guo [11] reported a study of a gas detection method based on hollow fiber enhanced Raman spectroscopy where, using a hollow-core capillary silver-coated on the inner wall, the signal intensity received was enhanced by more than 60 times, and the signal-to-noise ratio by about 6 times. In 2017, Fan [12] used two kinds of hollow-core fiber to develop an on-line Raman detection system, in work which reported mainly on how best to couple the hollow fiber to conventional fiber in such a practical Raman measurement system. This paper builds on that previously reported research to demonstrate an innovative probe design and show its performance for micro-sample analysis.

II. KEY UNDERPINNING PRINCIPLES

A. Raman scattering - key principles

Whilst the principles of Raman spectroscopy are well known, the key issues underpinning the design of the system used in this work are summarized below. Raman spectroscopy is commonly used to provide a structural fingerprint by which molecules can be identified through an inelastic light scattering process, shown schematically as in Figure 1. If the energy of the final state is higher than that of the initial state, the scattered photon will be shifted to a lower frequency (lower energy) – the Stokes shift. If the energy at the final state is lower, the scattered photon will be shifted to a higher frequency – the anti-Stokes shift [13], [14], [15], [16].

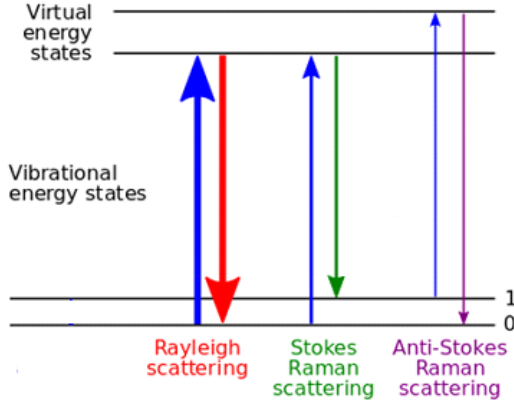

Fig. 1. Schematic diagram of the Raman scattering process

B. Light transmission mechanism of hollow-core fiber

The principle of light transmission in a hollow-core, air filled fiber is governed by Fresnel's law, as illustrated in Figure 2. This hollow core also serves as the cavity in which the sample to be analyzed is placed. Incident light is refracted at the wall of the quartz fiber and the refracted light further undergoes total internal reflection at the silicone rubber cladding, as shown in Figure 3. This process will be affected by the sample to be studied being inserted in the fiber hollow core, as discussed later in the paper [17], [18].

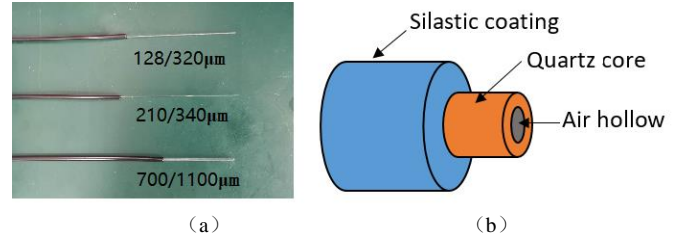

Fig. 2. (a) Photograph of three different hollow core fibers evaluated in this work. (b) Generic structure of the hollow-core fiber used

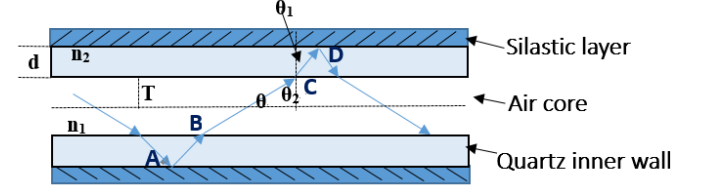

Fig. 3. Light transmitted in the hollow-core fiber

With reference to the schematic of the light transmission shown in Figure 3, a simple model of the operation of the hollow-core fiber can be used, taking into account the angle of incidence of the light and the energy distribution. The optical path 'AB' is the same as 'CD', which is given by $\frac{d}{\sin \theta_2}$, where 'BC' is $\frac{2T}{\sin \theta}$. Therefore, the effective optical path of the sample cavity in the hollow-core fiber K can be given by:

$$K = \frac{BC}{AB+BC+CD} = \frac{\frac{T}{\cos \theta_1}}{\frac{T}{\cos \theta} + \frac{d}{\cos \theta_2}} \quad (1)$$

Under the conditions where the angle between the incident light and the central axis is θ , the core diameter of the air core layer is T, and the thickness of the quartz layer is d, the refractive index in the sample cavity is n_1 , and the refractive index of the quartz fiber layer is n_2 .

According to the Beer-Lambert law:

$$n_1 \cdot \sin \theta_1 = n_2 \cdot \sin \theta_2 \quad (2)$$

$$\sin \theta = \cos \theta_1 \quad (3)$$

Combining the above equations gives:

$$K = \frac{\frac{T}{\sin \theta} \frac{1}{d}}{\frac{T}{\sin \theta} + \frac{1}{\sqrt{1 - \frac{n_1^2}{n_2^2} \times \cos^2 \theta}}} = \frac{T \sqrt{n_2^2 - n_1^2 \cos^2 \theta}}{T \sqrt{n_2^2 - n_1^2 \cos^2 \theta} + n_2 d \sin \theta} \quad (4)$$

Therefore the effective optical efficiency, K, of hollow fiber can be related to key parameters which are the incident angle θ , n_1 and n_2 .

III. RAMAN SIGNAL DETECTION SYSTEM

The Raman system developed consists of a laser, a marine optical Raman spectrometer, a Raman light-dividing device created using a hollow-core fiber, an optical mount and a fiber coupling sleeve. The specifications of the Raman spectrometer set up used are as shown in Table 1:

TABLE I
THE RAMAN SIGNAL DETECTION SYSTEM USED

Parameter	Value
Laser wavelength	785nm
Laser power range used	0-400mW
Raman spectrum detection probe design	Based on hollow-core fiber
Hollow-core fiber diameters used (the first figure is the diameter of the optical fiber air core / the second is the external diameter of quartz fiber)	(a)128/320 μ m (b)210/340 μ m (c)700/1100 μ m
Scanned Wavelength Range	400~2000 nm
Hollow-core fiber Length	0.5m
Fiber Joint Type	SMA905

Figure 4 shows a schematic of the Raman Signal Detection System used in this work, illustrating the hollow core fiber sensor itself as well as the laser, the spectrograph and the lenses and filters used to create the overall detection system.

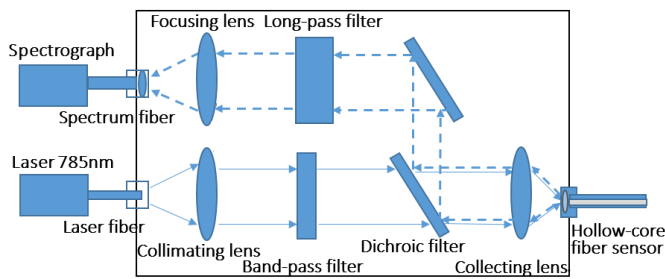

Fig. 4. Schematic diagram of the design and structure of the Raman system

IV. TEST RESULTS AND ANALYSIS

A. Effect of fiber core diameter on excitation light output power

In order to determine the effect of the fiber core diameter on the excitation light, three significantly different diameters of hollow-core fiber of 128 μ m, 210 μ m and 700 μ m respectively (as noted in Table 1) were used with a hollow-core fiber of length 0.5m.

In the test setup (a photograph of which is seen in Figure 5), the hollow-core fiber is placed in a black box and clipped vertically at the middle position of the adjustment frame, following which the two fiber ends were cut and flattened. As can be seen from Figure 4, the input end of the hollow-core fiber is connected to the focusing mirror of the Raman light-dividing device through a coupling sleeve where the focal spot size of the Raman light-dividing device is 158 μ m, and the lens focal length is 7.5mm. The output end of the hollow-core is connected to an optical power meter and the laser source is adjusted, using different output optical powers – then the coupled optical power is measured at the output end with the use of a commercial optical power meter.

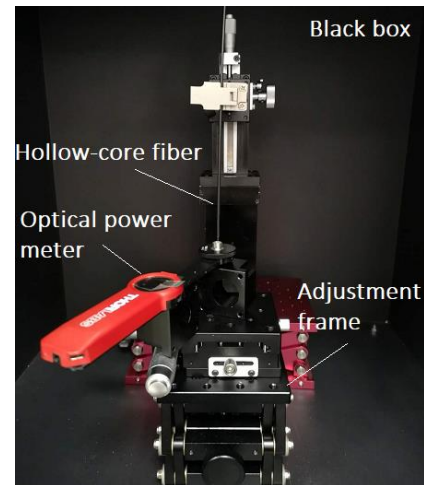

Fig. 5. Fiber optic probe measurement adjustment frame showing the key components of the measurement system

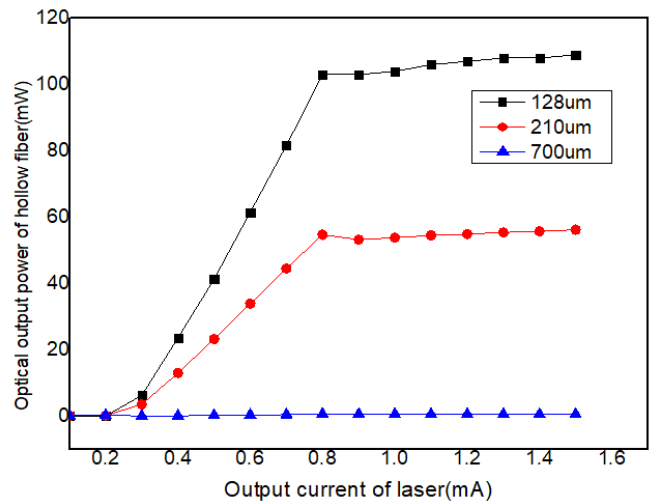

Fig. 6. Output optical power detection with 3 different fiber-types used (see Table 1)

Figure 6 shows the measured output optical power (at different input optical powers) with three different hollow-core fibers (as noted in Table 1). It can be seen that the 128 μ m fiber shows the maximum output light power because as the laser spot size is larger than the 128 μ m fiber air core diameter, the incident angle of the light is larger than the total internal reflection angle θ of the fiber. As result, a portion of the light beam is transmitted through the fiber wall, and the transmission loss of the light is reduced. The result seen from the 700 μ m hollow core shows that all input light power is lost through the fiber, regardless the intensity of the input power.

B. Influence of siphon sample time for liquid in the hollow core

In the experiment carried out, a sample of cyclohexane, (regularly used as a standard test sample for Raman detection), was used to optimize the key parameters and determine the best conditions for practical Raman spectroscopy with this set up and the hollow-core fiber probe described.

The setup used firstly to measure the sample penetration into the fiber – the sample ‘depth’ – is shown in Figure 7. The hollow-core fiber is normally inserted into the liquid sample,

and the liquid is gradually sucked into the hollow core through siphon action. The liquid height thus achieved is L_1 , this consisting of h_1 and h_2 , (where h_1 is the siphon height in the bare hollow fiber outside the fiber sleeve and h_2 is the siphon height within the fiber sleeve – thus the total siphon height, $L_1=h_1+h_2$).

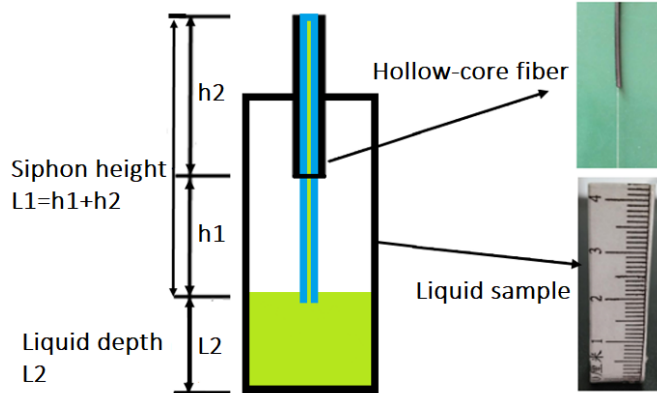

Fig. 7. Schematic of the experimental device showing the use of the siphon effect to draw the liquid into the fiber

With the use of this setup, the Raman Scattering light signal from the sample can be measured, noting any changes with time – that is, the change in the intensity of Raman characteristic peak produced by L_1 height over time. The liquid is gradually sucked into the hollow core through the siphon action, this changing with time. By measuring the intensity variation of the received signal at the known Raman characteristic wavelengths of 799nm and 802nm for the cyclohexane sample used, the relationship between these two parameters can be obtained, as shown in Figure 8.

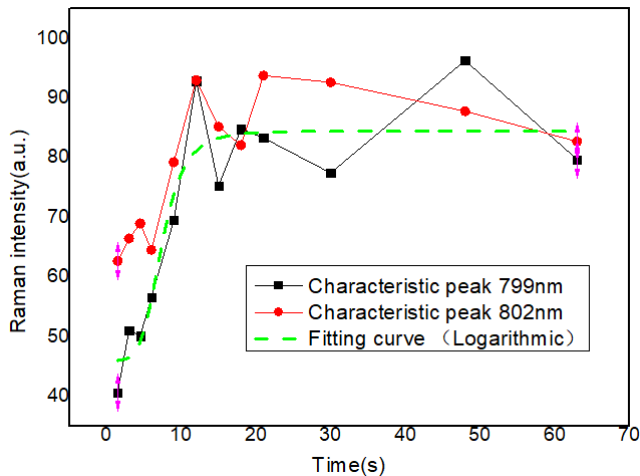

Fig. 8. Raman characteristic peak intensity of siphon process

From Figure 8, it can be seen that within the first 20 seconds, the intensities of the Raman characteristic lines at the two wavelengths noted increase as a function of time. After 20 seconds, the intensity essentially stabilizes. However, during the first 10 seconds, the height of the liquid in the hollow fiber rises and hence the volume of the sample increases as well, with consequent increase in the Raman scattering light signal. Beyond 20 seconds, the siphon effect saturates and the height of the liquid in the fiber does not change over time, resulting in a stable Raman signal intensity.

C. Influence of the sample depth outside the hollow-core fiber

An experiment was carried out to determine the influence of the sample depth outside the hollow-core fiber. In order to eliminate the effect induced by the sample within the hollow fiber, for each measurement the fiber was inserted into the sample liquid for at least 20 seconds to ensure that the siphon in the hollow-core fiber is complete and the same liquid height level was achieved. Then, for each sample depth outside hollow-core fiber, L_2 , the Raman spectral intensity was measured, as shown in Figures 9 and 10.

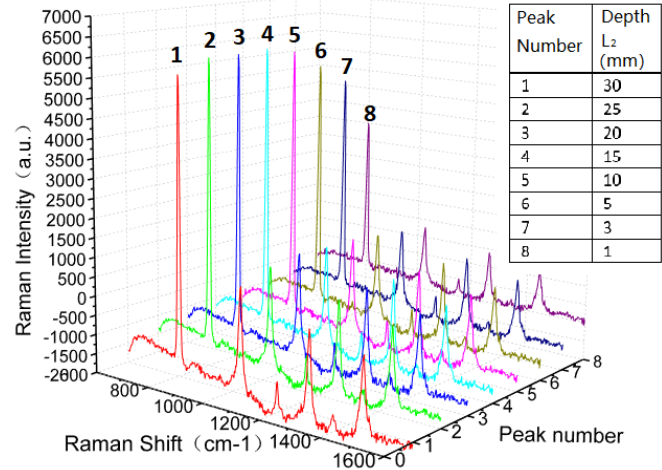

Fig. 9. Raman signal intensity from cyclohexane obtained at different sample depths, L_2

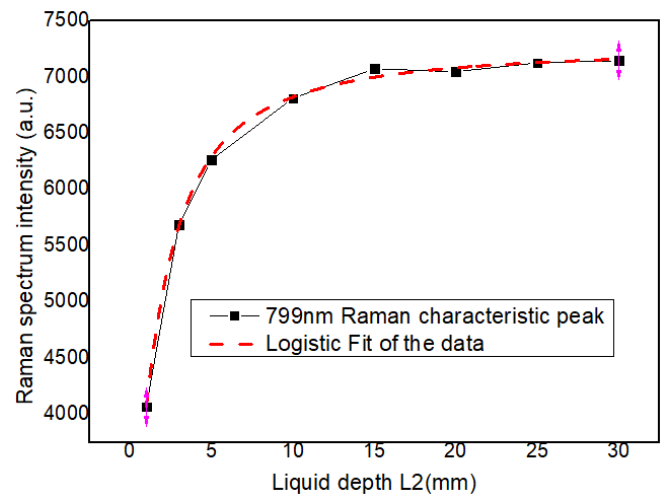

Fig. 10. Raman characteristic peak intensity as a function of liquid depth, L_2 (solid line) with a fitting curve (dashed line)

From Figures 9 and 10, it can be seen that when the sample depth outside the hollow-core fiber, L_2 , increases from 0 to 15mm, the Raman signal intensity increases with the depth of the liquid L_2 , while it saturates beyond that (as can be seen for L_2 changing from 15 to 30 mm). Thus it is not only the sample within the hollow-core fiber that contributes to the Raman scattering intensity, but also the same liquid that is outside and at the tip of the hollow-core fiber, within the range of values of L_2 that can contribute the scattering intensity. Raman signals can be expressed under certain conditions [19] by:

$$I = K\phi^0 C \int_0^b e^{-(\ln 10)(k_0+k)z} h(z) dz \quad (5)$$

Under the conditions where the Raman intensity is I , the Raman Scattering Cross Section is K , the laser incident power on sample surface is Φ^0 , the sample concentration is C , the absorption coefficient of incident light is k_0 , the absorption coefficient of scattered light is given by k . Further, the distance between the incident light and scattered light paths is z and the transmission coefficient of the optical system is $h(z)$. Here the width of sample pool is given by b .

It can be seen from Equation (5) that under the same sample and test conditions, the Raman scattering cross section and the incident laser power etc. are constant, so the Raman intensity is related to the distance between the incident light and the scattered light paths. Due to the siphon effect, the height of the sample in the hollow fiber is given by a variable L_1 and the sample depth outside the hollow-core fiber is given by L_2 . When the value of L_1 is unchanged, it can be seen from Equation (5) that the Raman intensity is the integral of L_2 in the range of $0 \sim b$ and saturation occurs at $b=15\text{mm}$.

D. Design of the enhanced Raman probe

Based on the results described above, it was clear that a greater sensitivity from the probe design was desirable and so a new design of an enhanced Raman sensor probe using the hollow-core fiber to measure the liquid samples was developed. The structure of the probe is shown in Figure 11, where the hollow fiber was inserted into a fiber sleeve, at the end of which is a metal reflector, with a fixed base. For this probe to be used to make similar measurements on a liquid sample, the hollow-core fiber is inserted into the sample and, waiting for 20 seconds or more ensures the sample fully fills the inside of the hollow fiber. Then the hollow fiber is inserted into the fiber sleeve, the metal reflector is then attached to the end of the fiber sleeve and attached to the fixed base. The signal is enhanced in this case where the forward Raman scattering light is reflected and collected together with the backward Raman scattering light, thereby increasing the Raman scatter signal.

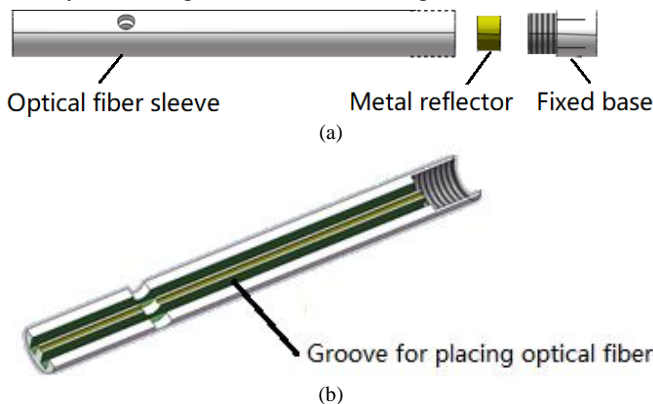

Fig. 11. (a) is the schematic diagram of the design and structure of the Raman Probe; (b) is the structure shown in cross section.

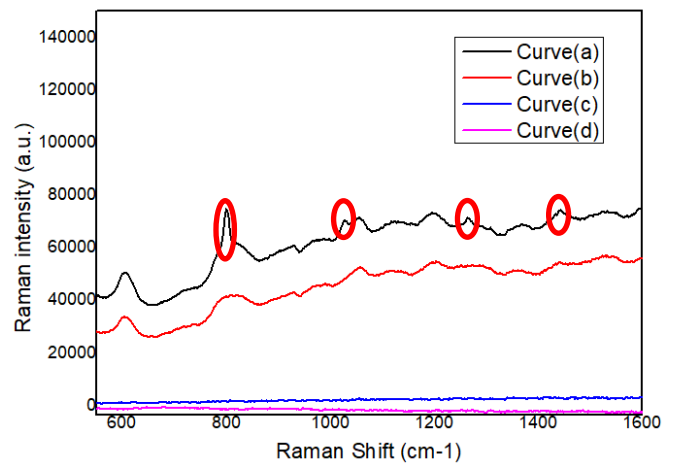

Fig. 12. Results of the enhanced reflection tests carried out using the hollow-core fiber optic probe. Curve (a) is the Raman intensity with the use of the sample and reflector, Curve (b) is the Raman intensity with the use of the reflector only, Curve (c) is the Raman intensity measured without either the sample and the reflector, and Curve (d) is the Raman intensity with the use of the sample but no reflector. Red ellipses on Figure (a) show the major peaks in the spectrum.

In Figure 12, curves (a) to (d) shows the results of a series of measurements made with the enhanced probe shown in Figure 11. Curve (a) shows the results obtained with the use of the sample and reflector, whilst curve (b) shows the data obtained with the use of the reflector only. Comparing the spectral intensity at the Raman characteristic peaks (highlighted by the red circles on the figure) with those at the non-Raman peaks, it can be seen that the Raman characteristic peaks are considerably enhanced in the first case, Curve (a). Further, curve (c) shows results obtained on measurements made without both the sample and the reflector, and hence only background light from the hollow fiber can be seen. Finally, curve (d) shows data obtained with use of the sample but no reflector and in this case the Raman characteristic spectrum detected from the sample is very weak. Taking these results together, it can be concluded that the intensity of the Raman characteristic peak of the sample, for example that at 800 cm^{-1} and measured using the probe, is at least 10^3 times greater than that without use of the reflector.

Looking more closely at the data obtained and shown in Figures 12, curves (a) and (b), the background noise can be removed by subtracting the data which were obtained with the use of the reflector but without the sample and then subtracting the background baseline, allowing in that way the enhanced Raman spectrum of cyclohexane to be obtained. The result of this is shown in Figure 13, from which the enhanced Raman spectrum, and in particular the characteristic peak at a wavelength shift of 800 cm^{-1} can be seen clearly.

This result shows that the enhanced probe design described in Figure 11 can be seen to significantly enhance the Raman scattered intensity. This arises because the hollow-core fiber is used as the sample cavity itself, and the combination of the hollow core structure and its excellent light guiding performance increases the area of interaction between the exciting light and sample. With the use of the reflector at the end of the fiber, it not only reflects the excitation light back into

the sample, but also reflect the forward Raman scattering light back to the detector. As a result, this probe combines the advantages of the hollow-core fiber of small size, a small volume of sample used, ease of operation and thus simplicity for in-situ detection.

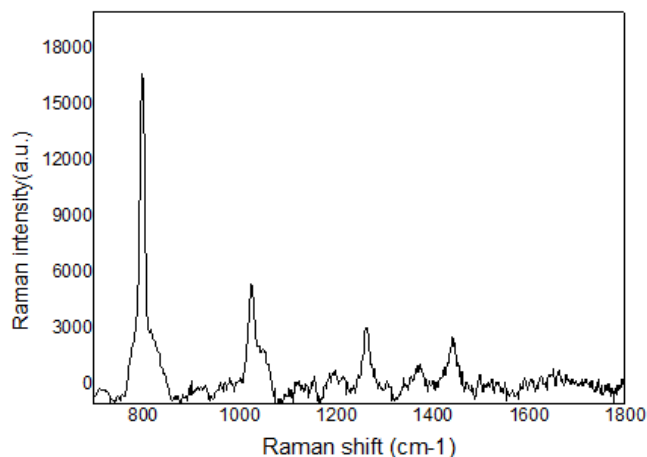

Fig. 13. Raman spectrum obtained from the test sample but with the reflected background signal removed

V. CONCLUSIONS

In this paper, a series of experiments has been carried out to develop an innovative hollow-core fiber-based measurement system. Through a systematic series of experiments with different probes which were designed, the relationships between the core diameter of the hollow-core fiber in the probe and the output optical power were measured and the effect of the siphon time and probe depth inserted into the sample were experimentally studied. Building on those results, an enhanced hollow-core fiber probe design was created, the experimental results obtained show that the enhanced Raman probe developed in this work can thus improve the Raman detection sensitivity by a factor of $10^3\sim 10^4$. This enhanced probe has the advantage of high detection sensitivity, small sample volume, simple design and potential for mass production. Indeed, it could be disposable for use in biomedical monitoring applications, where only very small samples of biofluids may be available, where probes are can be kept sterilized until use. This design presented provides an efficient, cost-effective detection approach using an innovative all-fiber Raman detection system.

REFERENCES

- [1] D. L. Jeanmaire, R. P. Vanduyne, "Surface Raman spectro electrochemistry Part I. Heterocyclic, aromatic and aliphatic amines adsorbed on the anodized silver electrode". *Electroanal Chem*, vol. 84, no.1, pp. 1-20, 1977.
- [2] M. Moskovits, "Surface-enhanced spectroscopy: a brief retrospective". *Journal of Raman Spectroscopy*, vol. 36, no.6-7, pp.485-496, 2010.
- [3] A. Matikainen, T. Nuutinen, P.& S. Honkanen, "A solution to the fabrication and tarnishing problem of surface-enhanced Raman spectroscopy(SERS) fiber probes", *Sci.Rep.*vol.5, 8320, pp.1-2, 2015.
- [4] J. C. Wang, W.H. Lin, E. Cao, X. F. Xu, W. J. Liang, X. F. Zhang, "Surface Plasmon Resonance Sensors on Raman and Fluorescence Spectroscopy", *Sensors*, vol.17, no.12, pp. 2719, 2017.

- [5] G. F. S. Andrade, J. G. Hayashi, M. M. Rahman, W. J. Salcedo, C. M. B. Cordeiro, A. G. Brolo, "Surface-Enhanced Resonance Raman Scattering (SERRS) Using Au Nanohole Arrays on Optical Fiber Tips", *Plasmonics*, vol.8, no.2, pp.1113-1121,2013.
- [6] L. T. Yu, J. M. Hu, X. H. Wang, J. K. Shen, Z.S. Xu "A Capillary /dual-optic Fiber Sensor for Raman Spectra Study", *Chinese Journal of light scattering*, vol.11, no.4, pp.305-309,2000.
- [7] T. Suzuki, Y. Kitahama, Y. Matsuura, "Development of a flexible fiber surface-enhanced Raman scattering (SERS) probe using a hollow optical fiber and gold nanoparticles", *Applied Spectroscopy*, vol.66, no.9, pp. 1022-1026,2012.
- [8] A. Lucotti, A. Pesapane, G. Zerbi, "Use of geometry optimized fiber-optic surface-enhanced Raman scattering sensor in trace detection" *Applied Spectroscopy*, Vol.61, no.3, pp:260-268,2007.
- [9] Z.W. Li, S.Q. Gao, W. Zhang, C.L. Sun, "Study on trace analysis by means of optical fiber resonance Raman spectra", *Chinese Journal of Analytical Chemistry*, vol.27, no.5, pp.570-573, 1999.
- [10] X. Yang, A. Y. Zhang, D. A. Wheeler, T. C. Bond, C. Gu, "Direct molecule-specific glucose detection by Raman spectroscopy based on photonic crystal fiber", *Anal Bioanal Chem*, vol. 402, pp.687-691, 2012.
- [11] J. Y. Guo, D.W. Yang, C.H. Liu, "Raman signal enhancement for gas detection using a hollow core optical fiber", *Spectroscopy and spectral analysis*, vol. 36, no.1, pp.96-98, 2016.
- [12] D. Y. Fan, "Research on on-line Raman detecting system", Nanjing university, 2017, pp. 42-54.
- [13] F.J. Garcia-Vidal, J. Pendry, "Collective theory for surface enhanced Raman scattering", *Physical Review Letters*, vol.77, no.6, pp.1163-1166, 1996.
- [14] G.C. Schatz, M.A. Young, R.P. Van Duyne, "Electromagnetic mechanism of SERS", *physics and applications*. vol.103, pp.19-45, 2006.
- [15] Y. Wei, Y.Y. Zhu, M.L. Wang, "A facile surface-enhanced Raman spectroscopy detection of pesticide residues with Au nanoparticles/dragonfly wing arrays", *Optik Optics*. vol.127, no.22, pp.10735-10739, 2016.
- [16] Y. Liu, J. Y. Wang, J. Q. Wang. "Preparation of Surface Enhanced Raman Substrate and its characteristic". *Applied Optics and Photonics China*, Beijing, vol.10460, pp.104601K-1—104601K-6, Sep.2017.
- [17] H. Yang, X.H. Sun, M.D. Zhang, "Experiment and theory analysis of hollow optical fiber", *Electronic components & materials*, vol.22, no.5, pp. 17-20, 2003.
- [18] J. J. Guo, D. W. Yang, C. H. Chun, "Raman signal enhancement for gas detection using a hollow core fiber". *Spectroscopy and spectral analysis*, vol.36, no.1, pp.96-98, 2016.
- [19] J. H, J. M. H. Application progress of Raman Techniques in Analytical chemistry. *Chinese Journal of Analytical Chemistry*. Vol.28, no.6, pp.764-771, 2000.



Yuan Liu was born in Shandong province, China, in 1981. She received the M.S. degrees from the China University of Petroleum (Huadong) in 2007 and then worked in the Laser institute of Shandong Academy of Science.

She has engaged in research in optical fiber sensing technology in the Laser Institute of THE Shandong Academy of Sciences, mainly on distributed temperature sensing and systems based on Raman scattering, using the Raman scattering principle to analyze the precision of temperature monitoring and researching into mathematical methods to improve the spatial resolution and the accuracy of its positioning. At present, she is engaged in spectroscopic analysis based on molecular absorption, Raman scattering and fluorescence spectra for trace matter detection in food safety. She has published 12 articles and 3 patents and holds 4 provincial science and technology awards, and has participated in scientific research work on a number of national and provincial projects.



Jinyu Wang received the B. Sc. degree in Measurement & Control Technology and Instrument and the M.Sc. degree in Detection Technology from Shandong University, in China, in 2004 and 2007 respectively. Afterwards, she became an assistant research fellow in optical fiber sensing with Laser Institute of Shandong Academy of Science until the end of 2016. She is currently an associate research fellow with Laser Institute, Qilu University. Her research interests are in the field of optical fiber sensors, SERS substrate, and molecular recognition.



Zhen Li received the B.Eng. degree in vehicle engineering from Shandong Agricultural University, Taian, China, in 2012. He also received a M.S. degree in mechanical engineering from Shandong Agricultural University, in 2014. In 2015, he entered Laser Institute of Shandong Academy of Sciences. His research interests include the mechanical design and the design of optical fiber sensors.



Jiqiang Wang received the B.Eng. degree, M.S. degree in measurement technology and instruments from Shandong University of Science and Technology, Taian, China, in 2002 and 2005, respectively. He also received the Ph.D. degree in precision instrument and mechanics from Beihang University, Beijing, China, in 2010. In 2010, he joined Laser Institute of Shandong Academy of Sciences, Jinan, China, where he has been working on the development of optical fiber sensors for structural health monitoring. His research focuses on various structural monitoring issues raised by industry, e.g. leak identification of oil/gas/water pipes, using optical fiber sensing technologies.



Yanong Ning graduated from Xian Jiaotong University, China, with a BSc degree in Physics. He gained his PhD in Measurement and Instrumentation from City, University of London, UK. He held research fellowships at the University of Kent and City London University respectively. Dr. Ning currently is a Senior Research Fellow of Laser Institute, Qilu University of technology (Shandong Academy of Sciences). He has had a wide range of careers in R&D of optic fiber sensors technologies and their industrial applications/business, the management of optical fiber sensor manufacture, sales, marketing and business development in the optical sensor industry. He worked as a business development manager/director and marketing director, responsible for sales,

marketing and business development of optical communications semiconductors and sensor in the Asia Pacific region. Dr. Ning has extensive experience in fiber optical sensor technology development, industrial application and commercialization in China, Asia and UK.



Tongyu Liu received the B. Eng. degree in radio electronics from Shandong University, Jinan, China, in 1983, and the Ph.D. degree in materials science from Brunel University London, U.K., in 1999. After 14 years of study and work in U.K., he joined Laser Institute of Shandong Academy of Sciences in 2004, undertaking research in novel optical fiber sensor development for physical and gas sensing. His recent research interests have been focused on fiber optic sensors for safety monitoring in coal mine, petrochemical, and power industries. He has authored and co-authored more than 150 journal and conference papers and more than 20 patents.



Kenneth T.V. Grattan received the B.S degree in physics and the Ph.D. degree from Queen's University, Belfast, U.K., in 1974 and 1978, respectively. He became a Postdoctoral Research Assistant at Imperial College, London, U.K. His research during that period was on laser systems for photophysical systems investigations, and he and his colleagues constructed some of the first of the then new category of excimer lasers (XeF, KrF) in Europe in 1976. His work in the field continued with research using ultraviolet and vacuum ultraviolet lasers for photolytic laser fusion driver systems and studies on the photophysics of atomic and molecular systems. In 1983, he joined City University, London, after five years at Imperial College, undertaking research in novel optical instrumentation, especially in fiber optic sensor development for physical and chemical sensing. The work has led into several fields, including luminescence-based thermometry, Bragg-grating based strain sensor systems, white light interferometry, optical system modeling, and design and optical sensors for water quality monitoring. The work has been extensively published in the major journals and at international conferences in the field, where regularly he has been an invited speaker, and over 1300 journal and conference papers have been authored to date. Multimillion dollar sponsorship for the work has come from industry, the research councils in the U.K., the European Union, and the Professional Bodies, with over 30 Ph.D. students graduating during that time. He was awarded the degree of Doctor of Science by City University in 1992. Dr. Grattan was awarded the degree of Doctor of Science by City University in 1992. He was Chairman of the Applied Optics Division of the U.K. Institute of Physics and President of the Institute of Measurement and Control in 2000. He is a fellow of the UK's national academy of engineering, the Royal Academy of Engineering

