

Surviving the Ship Airwake

Towards a Scalable Turbulence Response
Model For the Helicopter-Ship Dynamic
Interface

*RAeS International Power Lift Conference,
November 2018*

Mr. T. Fell

Dr. M. Jump mjump1@liverpool.ac.uk

Dr. M. White mdw@liverpool.ac.uk

Prof. I. Owen i.owen@liverpool.ac.uk



UNIVERSITY OF
LIVERPOOL



@drmikejump



drjumpjets

Introduction

- Considerable research effort has been expended on research to reduce the time and cost associated with manned helicopter-ship operations, largely via simulation techniques
- Interest is growing in the use of unmanned vehicles from naval vessels
- The range of platforms in terms of size/shape etc. that could be used is far greater than current manned piloted platforms
- It would be helpful for designers to know in advance what the environment will be that their platform and its control system will have to contend with
- This could be to assess the capability of an existing platform or when designing from scratch
- The following introduces a project **that has created a novel scalable turbulence response model (STM)** to inform this design/assessment process

Method Overview

- The main activity of the project has been to create a scalable turbulence response model (STM)
- The aim here was to provide an empirical method that will allow rotorcraft control system designers to estimate the perturbations likely to be encountered in each axis when operating in a ship air wake
- A wide-ranging simulation study has been conducted to generate this empirical method, using a variety of tools and techniques, some unique to the University of Liverpool.
- The key steps in the process are indicated in the flow chart shown here

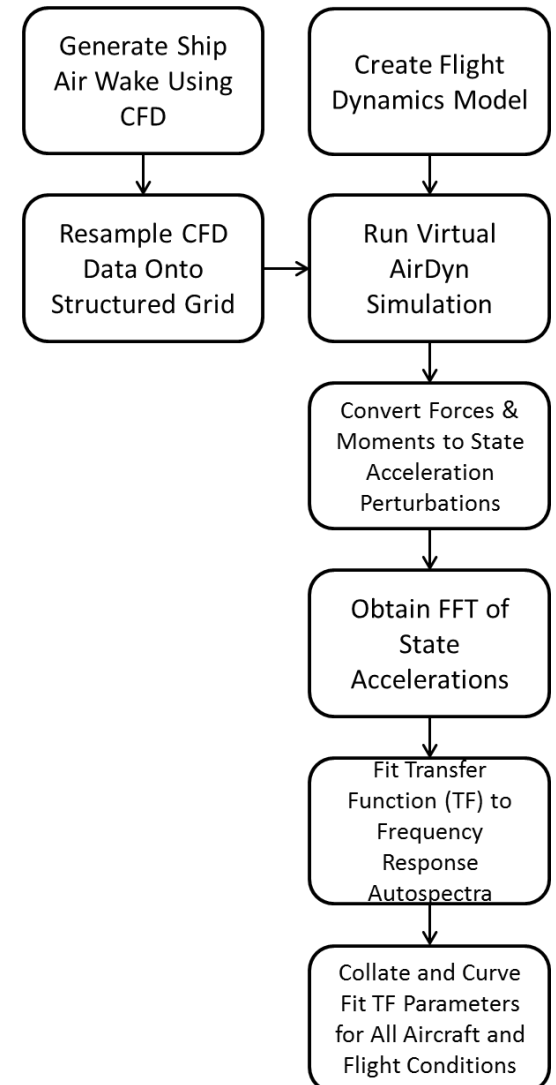

Flight Dynamics Models

- Four *representative* FLIGHTLAB flight dynamics rotorcraft models have been used for the study that cover a broad range of UAS classes/sizes/masses that might conceivably be operated from a naval vessel
- These were based upon data from:
 - Sikorsky Seahawk SH-60B;
 - Northrop Grumman Firescout MQ-8B;
 - Yamaha R-MAX
 - Align T-REX 700
- Each model was modified to allow it to interact with the simulated air wake

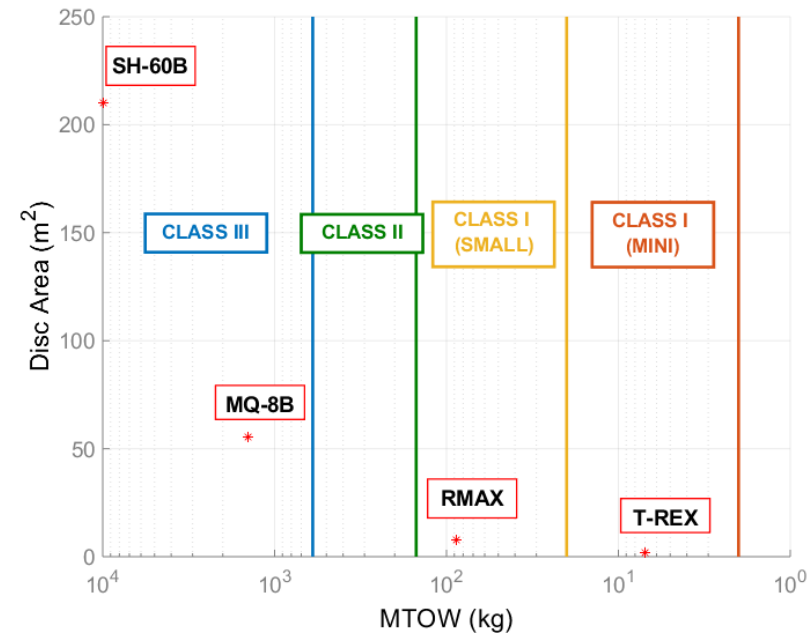

Ship Air Wake Generation

- The air wakes used in the study were generated using a time-accurate Computational Fluid Dynamics (CFD) Detached Eddy Simulation (DES)
- This provides three air wake velocity components (u,v,w) in an unstructured grid for 105 seconds at 100Hz. The first 15 seconds are discarded to allow the unsteady solution to settle. A sensitivity study was conducted to establish the appropriate parameters c.f. UoL manned simulation studies.
- Solutions computed for Headwind case with free stream velocity of 15, 20, 30 and 40kts using a ship model similar to a Type-45 class destroyer

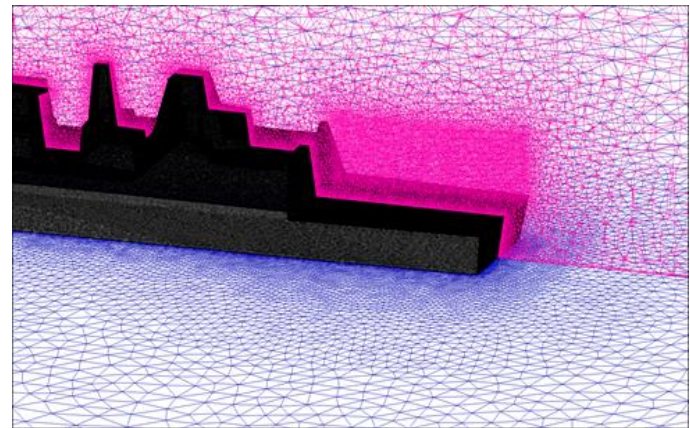
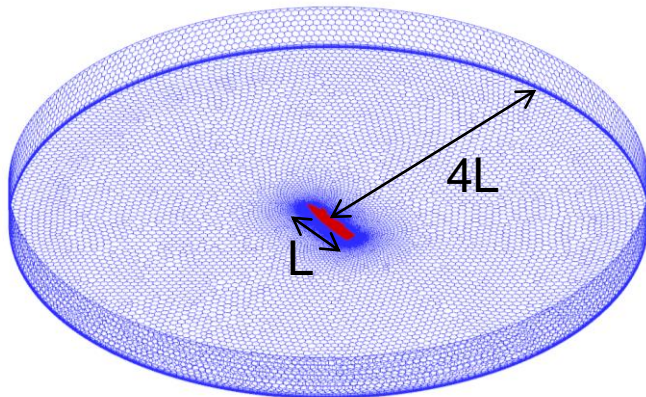

Map CFD Solution to Structured Grid

- The CFD solution is computed using an unstructured grid
- For processing with the FLIGHTLAB rotorcraft models, this needs to be interpolated to a structured grid
- Default grid is a cubic lattice structure with 1m node spacing

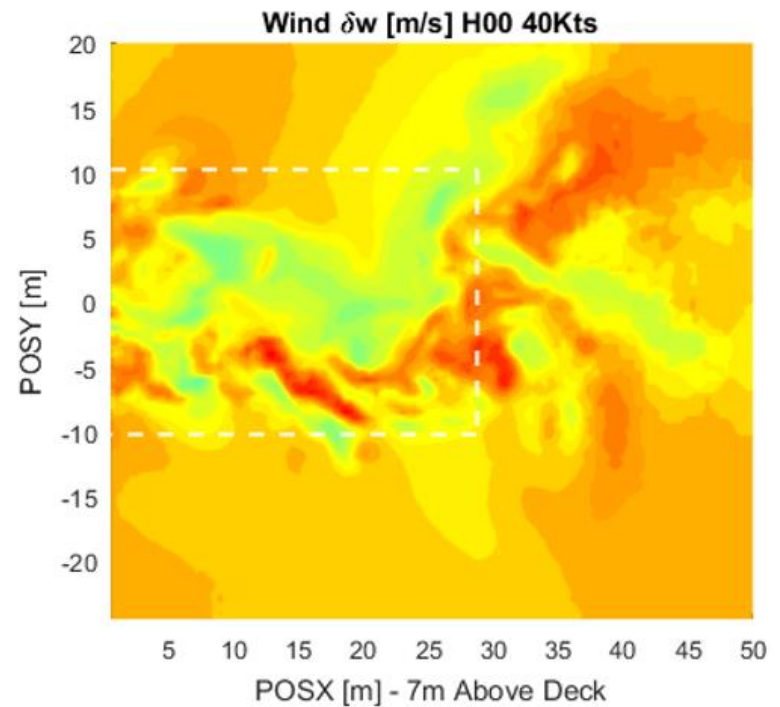
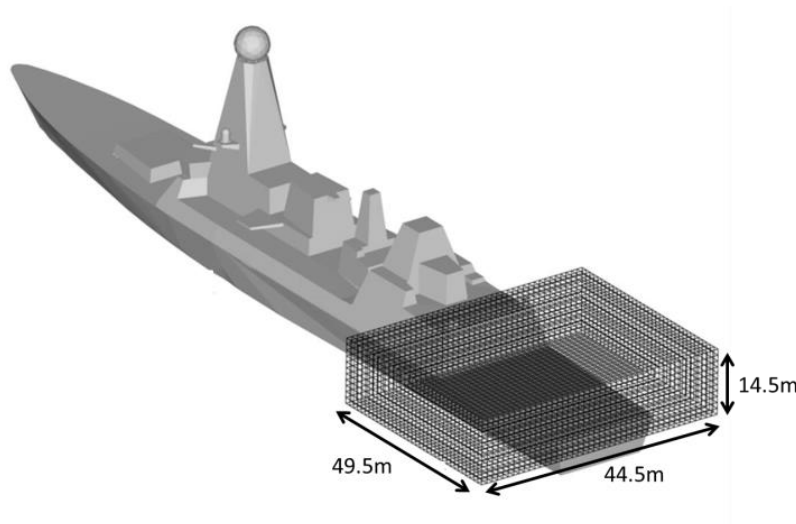

Virtual AirDyn(amometer)

- Each rotorcraft model was immersed in the simulated air wake at fixed locations. The model was held rigidly at each point to allow it to ‘measure’ the force perturbations experienced in the wake at that point in each translational and rotational axis
- Figure below shows an example (worst case) heave perturbation on the SH-60B
- These then converted to state acceleration perturbations by removing the mean and dividing by the aircraft mass/inertia tensor

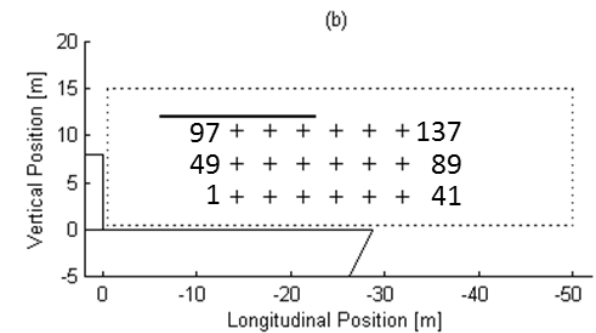
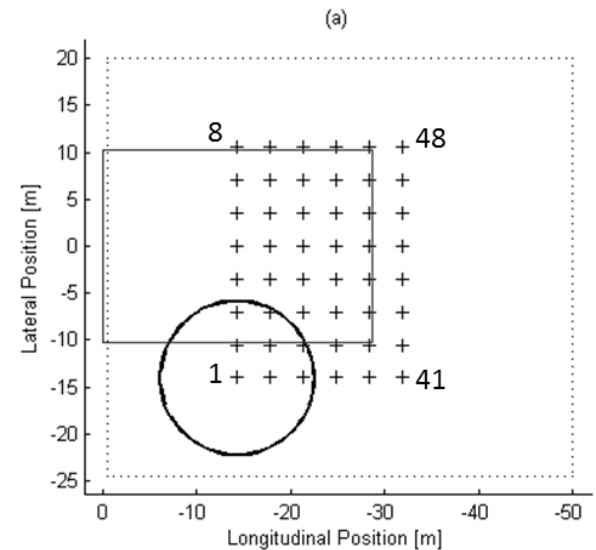
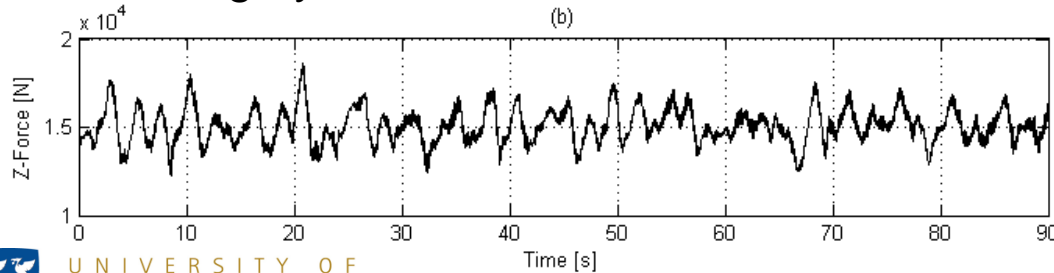

Obtain FFT of State Accelerations

- Each state acceleration is passed through the multi-window frequency response identification routine used by CIPHER[®]
- The lower frequency range is limited by the total signal length used in the identification. In CIPHER[®], this is based on there being at least two full oscillations present in the largest window size used.
- The upper frequency range was extended to 40 rad/s to accommodate the small UAS models whose turbulence cut-off frequencies were generally found to be much higher than the larger manned helicopters
- The FFT of the previous state acceleration response is shown below

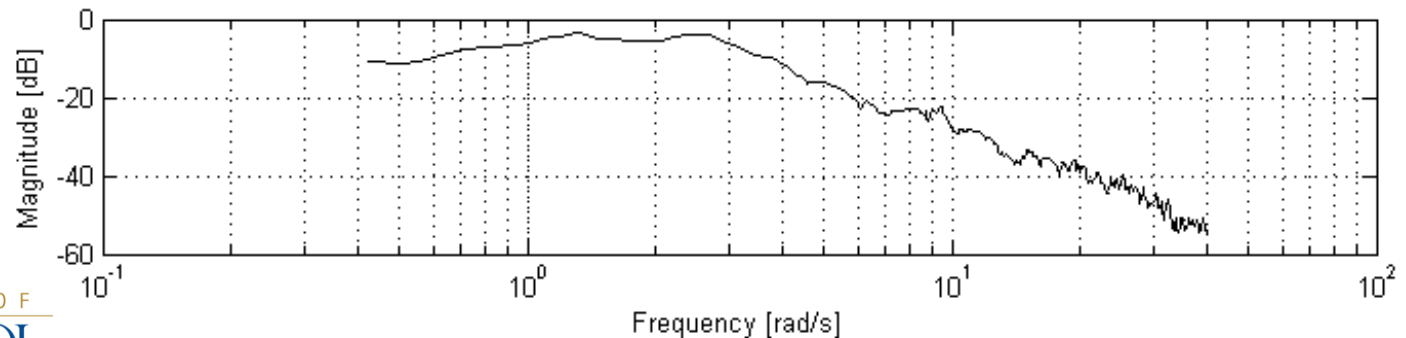

Non-Parametric Response Autospectra

- The output of the CIFER[®] system identification is the non-parametric turbulence frequency response autospectra for each translational (AX, AY, AZ) and rotational (RAX, RAY, RAZ) axis for each helicopter
- The autospectra were then approximated by a parametric 2nd order transfer function which was found to have the closest least-squares fit to the non-parametric response

$$G_a(s) = \frac{\sigma \omega^2}{(s + \omega)^2}$$

- This simple form was chosen to more easily facilitate the development of a scaling law based on the scaling of just two parameters; the perturbation break frequency, ω , and the perturbation magnitude standard deviation from the mean, σ
- The output data was ‘smoothed’ by using the perturbations from the deck position where the rotorcraft model was stationed and the 8 points that surround it

Non-Parametric Response Autospectra

- An acceptable fit was achieved for all aircraft by limiting the fit to the frequency range that contained the majority of the turbulent energy
- The upper frequency limit of the fit was set by calculating the frequency at 95% of the cumulative RMS of the relevant translational or rotational perturbation accelerations with the remaining frequency response information discounted

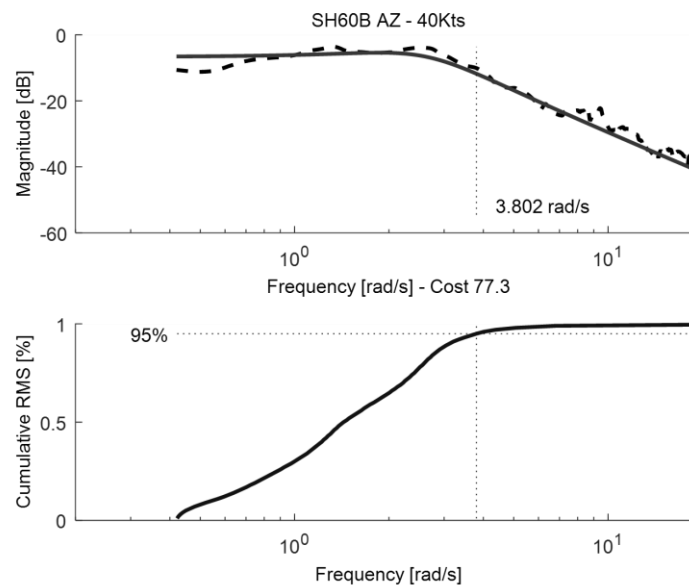

Fit Transfer Function Parameters

- The final goal of the process was to define a set of transfer functions to describe the turbulent response of an aircraft for a given disk loading
- To do this, the describing parameters for σ and ω needed to be defined in terms of the parameters that had been varied i.e. the ambient freestream wind speed, U , and the rotorcraft disk loading (representing the variation in aircraft size)
- The form of the curves to which the data has been fit, with the coefficients 'a', 'b' and 'c' obtained using a least squares regression, is shown below

$$\sigma = a_{\sigma} U^{b_{\sigma}} \left(\frac{M}{\pi R^2} \right)^{c_{\sigma}}$$

$$\omega = a_{\omega} U^{b_{\omega}} \left(\frac{M}{\pi R^2} \right)^{c_{\omega}}$$

Transfer Function Fits

- Three fits have been performed to try to ‘bound’ the results
 1. An ‘optimistic fit’, where the two lowest perturbation datasets have been considered
 2. A ‘standard fit’ where all data are considered equally
 3. A ‘conservative fit’ where only the two worst case rotorcraft datasets have been considered

Results of Transfer Function Standard Fit

- State Perturbation Standard Deviation (σ)

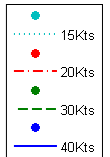
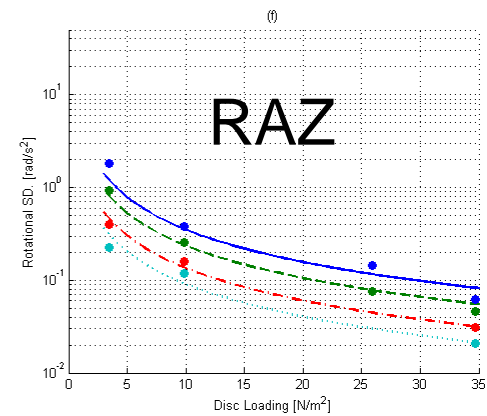
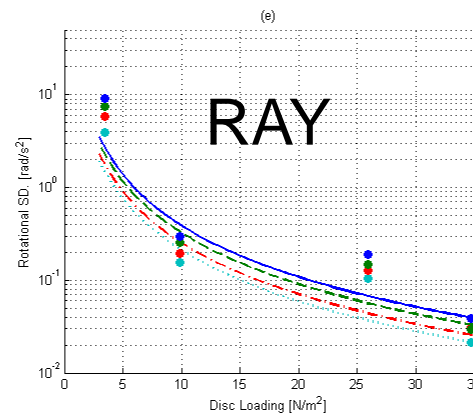
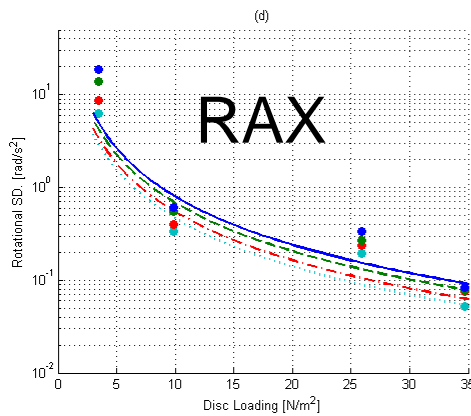
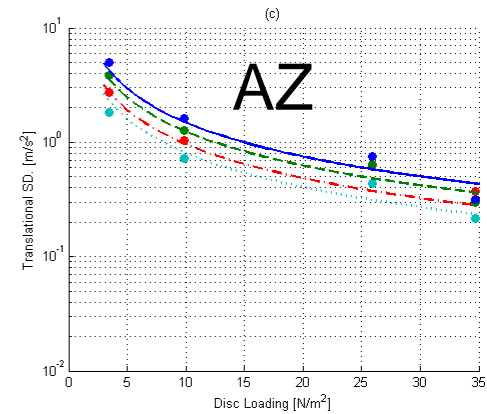
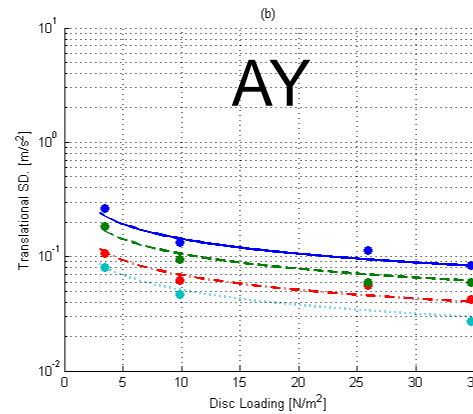
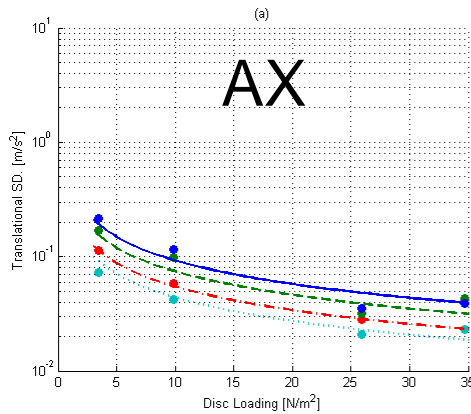

Results of Transfer Function Standard Fit

- State Perturbation Frequency (ω)

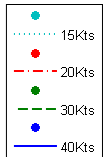
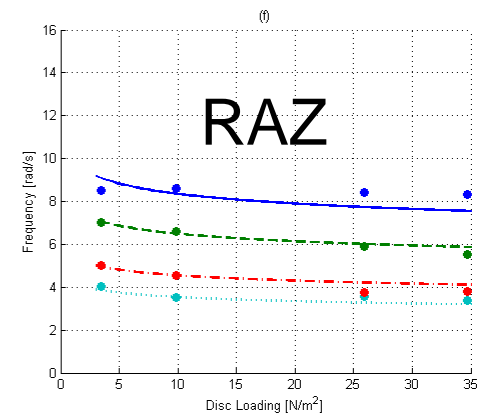
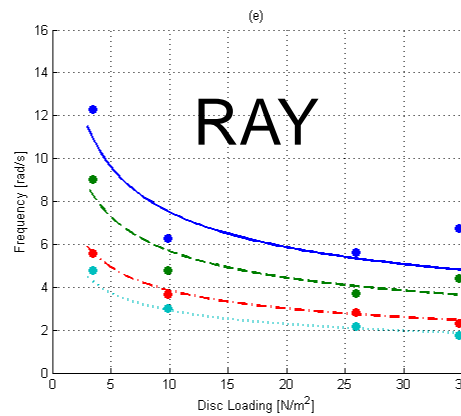
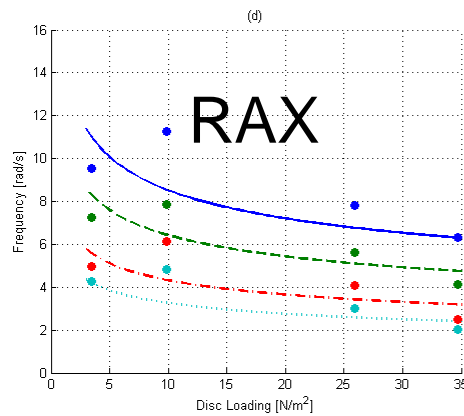
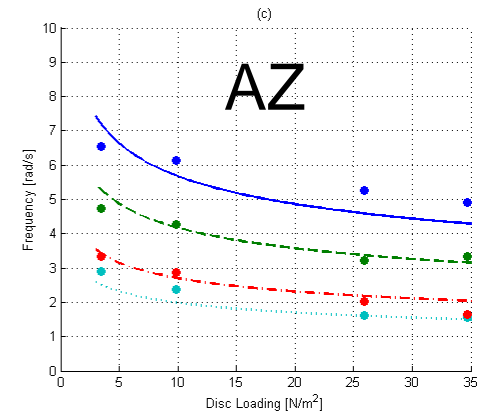
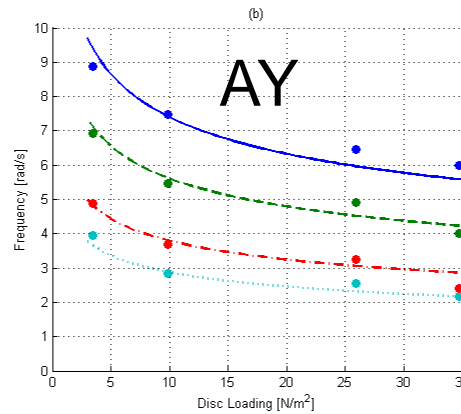
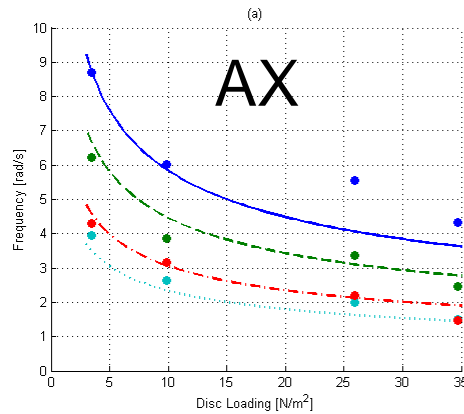

Scalable Turbulence Model Goodness of Fit

- None of the 'fits' fit the data perfectly
- The fitting routine is trying to fit all of the data monotonically increasing with wind speed
- However, not all of the data trends are monotonic – e.g. AZ SH60B Conservative Fit, σ
- Here, the largest σ arises for the 20kt wind, not 40kt wind
- This is likely to be due to a localised effect due to the flow conditions across the rotor
- This observation to be investigated further
- Also, remember that σ is the standard deviation of the perturbations about the mean, not the magnitude of the perturbation itself

Identified Data vs Original Dataset

- The STM data can be converted back into time-history data by playing a white noise signal through the scalable turbulence model transfer function with the appropriate σ and ω
- Plot below compares the original AirDyn data with the data recreated from the identified data
- As would be expected, the transfer function has acted as a low pass filter and has introduced a small phase shift

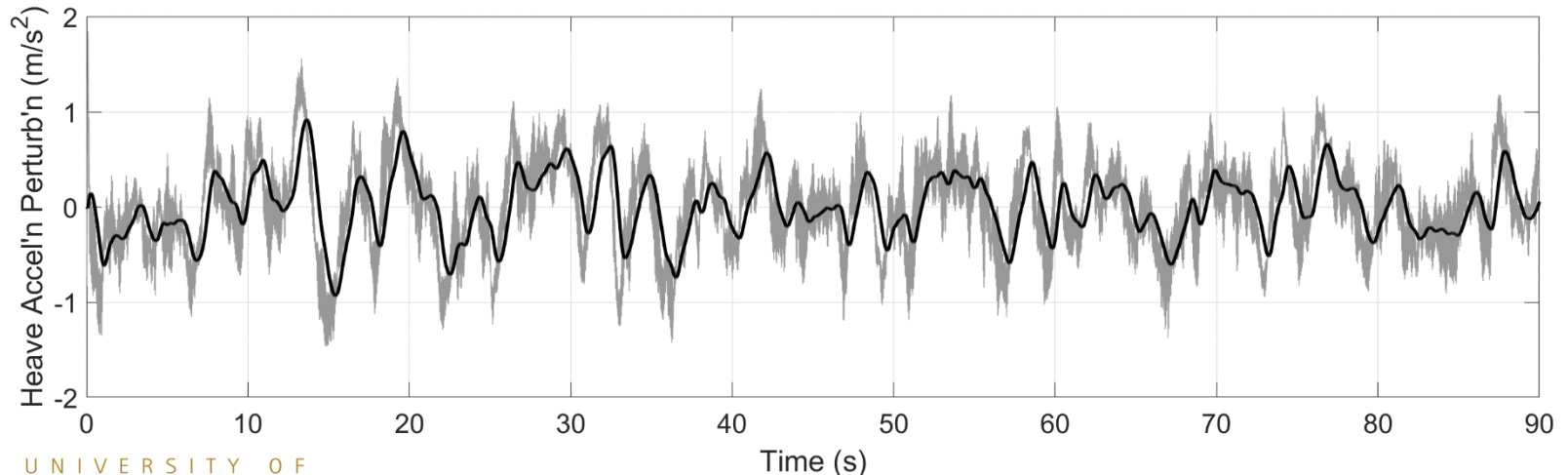

Unseen Data

- Two ‘unseen’ representative rotorcraft models were used to test the efficacy of the curves produced based upon data available for:
 1. Bell B412 (articulated rotor system)
 2. Airbus Helicopters BO-105 (hingeless rotor system)
- These models were used as they were readily available to the UoL.
Note: both fall within Class III
- Both have similar disk loadings

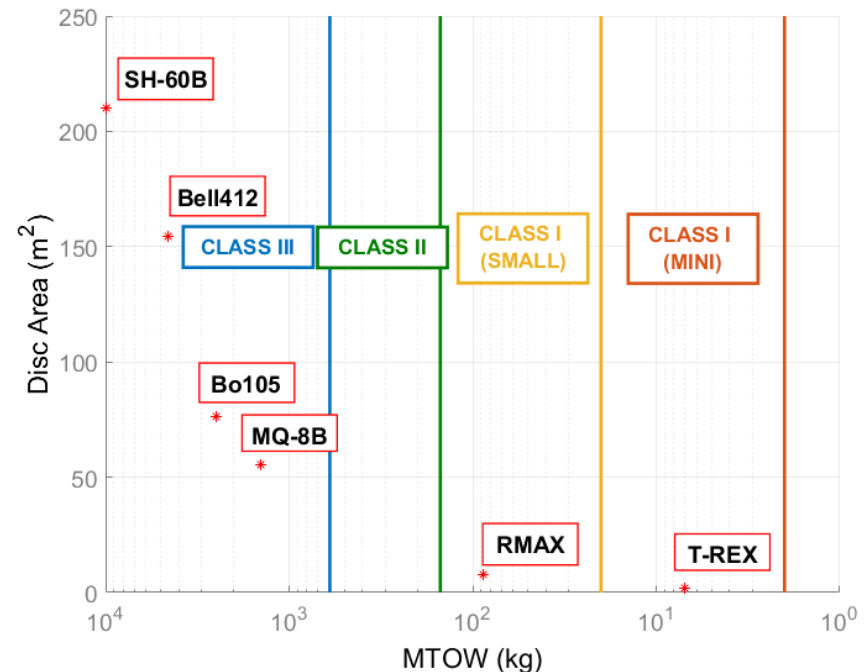

Unseen Data

- State Perturbation Standard Deviation, σ , (Standard Fit)

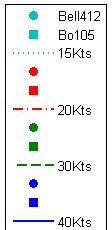
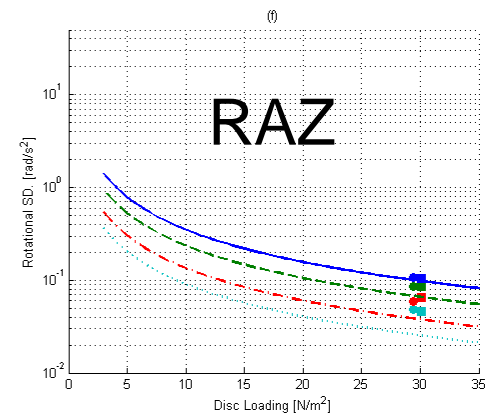
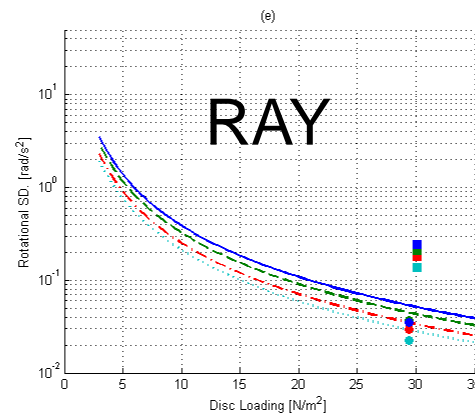
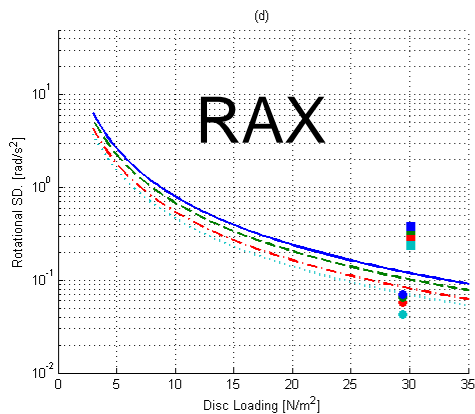
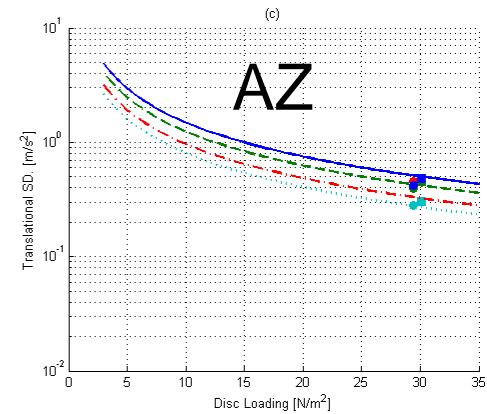
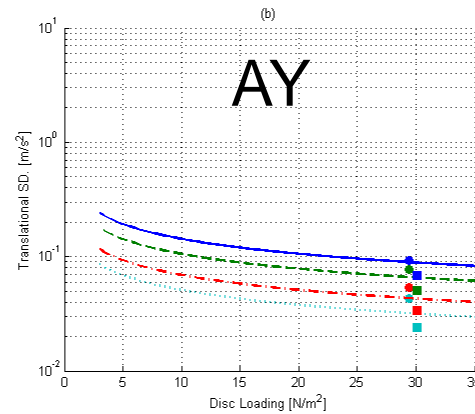
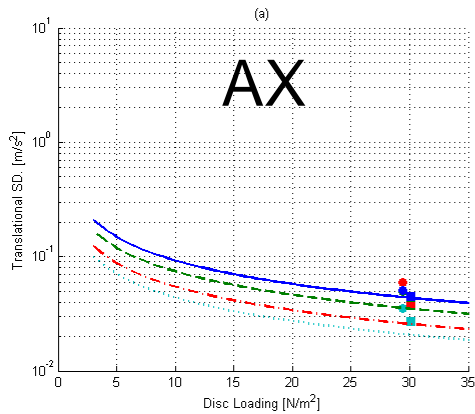

Unseen Data

- State Perturbation Frequency, ω , (Standard Fit)

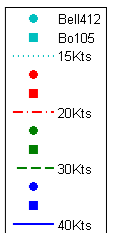
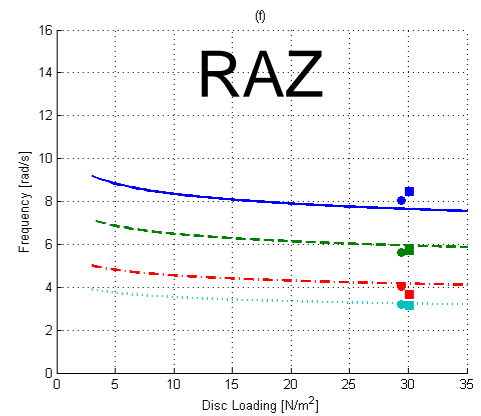
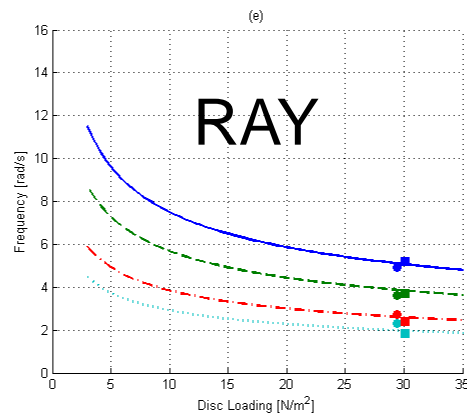
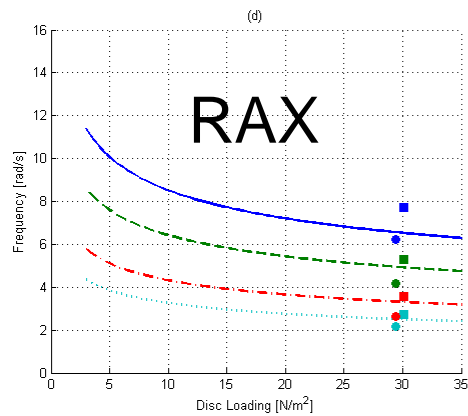
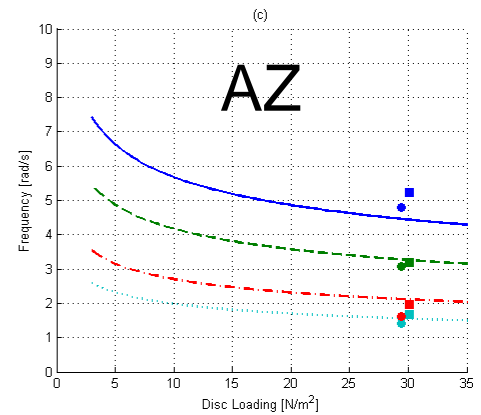
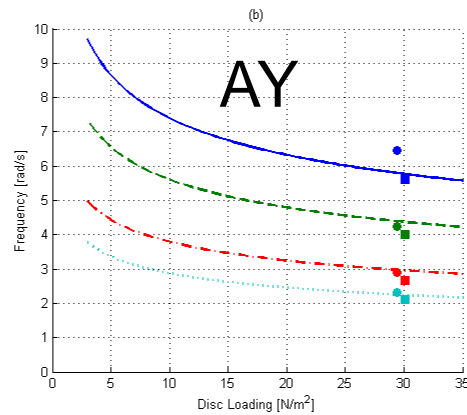
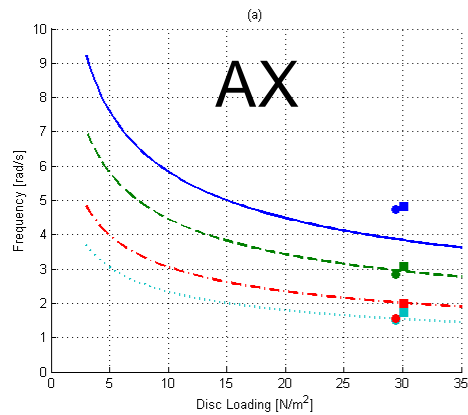

Using the STM

- The STM can be applied directly to an aircraft state space model, in a similar manner to the Dryden turbulence model
- Alternatively, the turbulence model can be fed through an inverse aircraft model to generate CETI type turbulence inputs to drive a state space or non-linear aircraft model (limited to 4 states AZ, RAX, RAY, RAZ due helicopter control inputs)

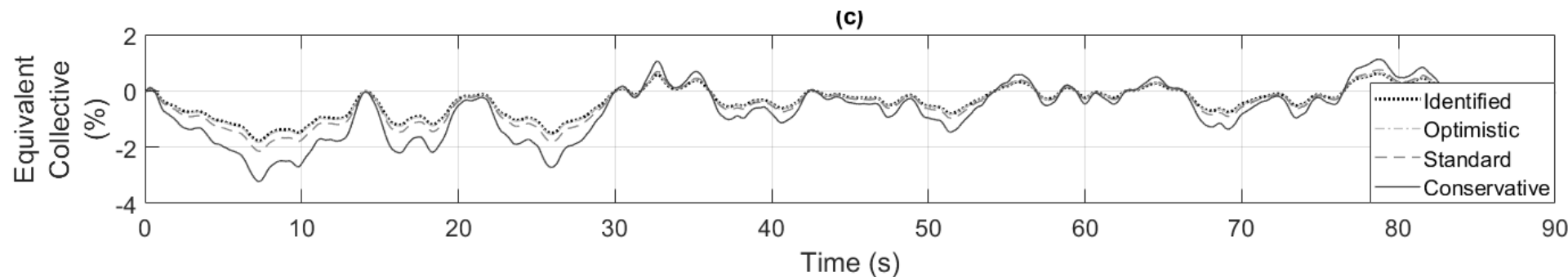

Concluding Remarks

- A process has been created to generate a novel predictive method for the turbulence/perturbations that would be experienced by a rotorcraft in a ship air wake for each rigid body translational and rotational state.
- For conventional articulated rotorcraft, the σ term (standard deviation of the response magnitude from the mean) seems to be well modelled by the standard fit curves.
- For hingeless, stiffer rotors, the σ term seems to be better modelled by the conservative fit curves for the RAX and RAY states. The standard fit curves appear to be satisfactory for the other states for this class of rotor head.
- For the break frequency term in the model, ω , the conservative fit curves appear to be the better model for both types of rotorcraft. The STM is not always truly conservative but this term is the less important of the two.

Limitations

- The process has been developed using conventional rotorcraft configurations only i.e. main and tail rotor aircraft
- *It is therefore uncertain how these results would pertain to novel vehicle configurations*
- The process has only been exercised and analysed using a Headwind data case.
- *This is ok provided off-beam winds do not generate larger u,v,w perturbations in the operational area of interest*
- The process has been developed and tested in a simulation environment only.
- *It would benefit from real world validation data*

Future Work

- Consider effect of the magnitude of the errors between the different STM fits and simulated aircraft data
- Undertake a control system design using STM as the guideline and test its efficacy using real-time simulation

| Any Questions?



The work reported in this paper was funded by DSTL under contract DSTLX1000074725. The authors would also like to thank both the National Research Council of Canada for providing data and specifications for the T-REX helicopter model and DSTG for providing the RMAX model and their assistance for this study as part of TTCP.