



PHD

Cardiovascular effects of beta-blockers in the central nervous system.

Sheridan, Robert

Award date:
1982

Awarding institution:
University of Bath

[Link to publication](#)

Alternative formats

If you require this document in an alternative format, please contact:
openaccess@bath.ac.uk

General rights

Copyright and moral rights for the publications made accessible in the public portal are retained by the authors and/or other copyright owners and it is a condition of accessing publications that users recognise and abide by the legal requirements associated with these rights.

- Users may download and print one copy of any publication from the public portal for the purpose of private study or research.
- You may not further distribute the material or use it for any profit-making activity or commercial gain
- You may freely distribute the URL identifying the publication in the public portal ?

Take down policy

If you believe that this document breaches copyright please contact us providing details, and we will remove access to the work immediately and investigate your claim.

CARDIOVASCULAR EFFECTS OF β -BLOCKERS

IN THE CENTRAL NERVOUS SYSTEM

Submitted by Robert Sheridan
for the degree of
Doctor of Philosophy
of the University of Bath

1982

Attention is drawn to the fact that copyright of this thesis rests with its author. This copy of the thesis has been supplied on condition that anyone who consults it is understood to recognise that its copyright rests with its author and that no quotation from the thesis and no information derived from it may be published without the prior written consent of the author.

This thesis may be made available for consultation within the University library and may be photocopied or lent to other libraries for the purposes of consultation.

Robert Sheridan

ProQuest Number: U336003

All rights reserved

INFORMATION TO ALL USERS

The quality of this reproduction is dependent upon the quality of the copy submitted.

In the unlikely event that the author did not send a complete manuscript and there are missing pages, these will be noted. Also, if material had to be removed, a note will indicate the deletion.

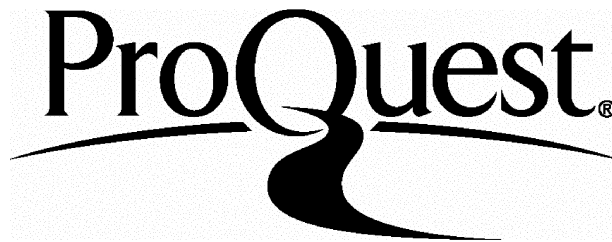

ProQuest U336003

Published by ProQuest LLC(2015). Copyright of the Dissertation is held by the Author.

All rights reserved.

This work is protected against unauthorized copying under Title 17, United States Code.
Microform Edition © ProQuest LLC.

ProQuest LLC
789 East Eisenhower Parkway
P.O. Box 1346
Ann Arbor, MI 48106-1346

UNIVERSITY OF BATH
LIBRARY

23

-3 SEP 1982

FRD

PHD

ACKNOWLEDGEMENTS

Firstly, I would like to thank my 2 academic supervisors, Dr. Peter Redfern and Mr. Tony Draper, and my industrial supervisor, Dr. David Clough of ICI, without whom none of this work would have been possible. I am particularly indebted to Dr. Clough and Messrs. Paul Marshall and Chris Allott, also of ICI, all 3 of whom gave freely of their time and effort either to advise me on my experimental method or to discuss matters pharmacological.

I thank the Science Research Council for financial support in the form of a CASE award with ICI plc, with whom I spent 6 months of the duration of this study.

I am most grateful to Professor M. Manning of the Medical College of Ohio for the gracious gift of arginine-vasopressin antagonist.

I am also grateful to my many colleagues in the Pharmacology Department at Bath with whom I've had innumerable stimulating discussions, occasionally concerning pharmacology. In particular, I would like to thank Dr. Alan Daugherty who critically read much of the final manuscript.

Finally, and most importantly, I am greatly indebted to my Mother for continuing support, in every sense of the word, throughout my academic years.

Everything has been thought of before,
but the problem is to think of it again.

- Johann W. von Goethe

(1742-1839)

SUMMARY

1. The present study was concerned with the effects on the cardiovascular system of centrally injected β -blockers. Several lines of approach were used.
2. Intracerebroventricular (icv) injections of dl-propranolol lowered blood pressure and heart rate in halothane (H)-anaesthetised rats, whereas similar injections in thiobutobarbitone (T)-anaesthetised rats only lowered heart rate. The hypotensive effect icv dl-propranolol in H-anaesthetised rats is discussed in terms of a systemic action of the drug following leakage from CSF to the circulation.
3. In H-anaesthetised rats intrahippocampal (i.h.) injections of l-propranolol (but not d-propranolol) produced dose-related falls in blood pressure and heart rate which were of greater magnitude than those seen after intravenous injection of similar doses. I.h. injection of atenolol and timolol failed to affect blood pressure and heart rate. The hypotensive action of l-propranolol in the hippocampus appeared to be unrelated to β -blockade or membrane stabilising activity.
4. In T-anaesthetised rats icv pretreatment with β -blockers unmasked a pressor response to icv adrenaline. Icv adrenaline alone produced no significant changes in blood pressure. The order of potency of the β -blockers was ICI 118551 > dl-propranolol > atenolol, suggesting that central β_2 -blockade was necessary for the effect

to be expressed. d-Propranolol was ineffective in this respect. Various pharmacological manipulations suggested that the pressor response to adrenaline following icv injection of β -blockers was due to a central action of the drug, although this was not proved conclusively.

5. In T-anaesthetised rats icv β -blockers generally failed to modify the pressor responses evoked by electrical stimulation in the anterior hypothalamus, posterior hypothalamus, amygdala and median raphe nucleus.
6. Third ventricle infusions of propranolol in the chloralose anaesthetised cat modified the pressor responses produced by electrical stimulation in the ansa lenticularis. The return of blood pressure to pre-stimulation levels following cessation of stimulation was delayed by centrally, but not intravenously, injected propranolol. This effect appeared to be related to the membrane stabilising properties of the β -blocker.

CONTENTS

Chapter 1	INTRODUCTION	1
1.1	β -adrenoceptor blockers - an historical note.....	2
1.2	Characteristics of primary hypertension.....	2
1.3	Haemodynamic profile of β -blocker-induced hypotension.....	3
1.4	Potential mechanisms of β -blocker-induced hypotension.....	5
1.5	The hypotensive action of β -blockers - an effect within the CNS?	11
1.6	Cardiovascular effects of centrally injected isoprenaline.....	27
1.7	β -adrenoceptors in the CNS.....	30
1.8	Cardiovascular effects of centrally injected α -adrenergic agonists and adrenaline.....	32
1.9	Aims of the present study.....	35
Chapter 2	MATERIALS AND METHODS	36
2.1.1	General considerations.....	37
2.1.2	The stereotaxic technique.....	37
2.1.3	Histological techniques.....	39
2.2.1	Central injection of β -blockers in halothane anaesthetised rats.....	40
2.2.2	Icv injection of propranolol.....	41
2.2.3	Intrahippocampal injection of β -blockers.....	43

2.2.4	Anatomical localisation of the responses to intrahippocampal injection of β -blocker.....	43
2.3.1	Icv injection of drugs in thiobutobarbitone anaesthetised rats.....	43
2.3.2	Effect of icv β -blocker pretreatment on the response to icv adrenergic agonists.....	44
2.3.3	Effect of icv β -blocker pretreatment on the response to icv adrenergic agonist - consequence of prior icv injection of phentolamine.....	45
2.4.1	Effect of icv β -blockers on the cardiovascular responses to monopolar electrical stimulation in various brain areas in thiobutobarbitone anaesthetised rats.....	45
2.4.2	Electrical stimulation.....	47
2.4.3	Protocol for electrical stimulation experiments.....	48
2.4.4	Verification of stimulation site.....	48
2.5.1	Preparation of anaesthetised cats for third ventricle infusion and electrical stimulation.....	49
2.5.2	Monopolar electrical stimulation in the ansa lenticularis.....	50
2.5.3	Third ventricle infusion of drugs.....	51
2.5.4	The effect of drugs on the cardiovascular responses to ansa lenticularis stimulation.....	51
2.6.1	Drugs and general chemicals.....	52
2.6.2	Doses of drugs.....	53
2.7.1	Data analysis.....	53

Chapter 3	RESULTS	55
3.1	General considerations.....	56
3.2	Resting blood pressure and heart rates of anaesthetised rats.....	56
3.3	Icv injection of β -blockers.....	56
3.4	Leakage of dl-propranolol from CSF.....	57
3.5	Intravenous injection of dl-propranolol.....	58
3.6	Intrahippocampal injection of propranolol.....	58
3.7	Anatomical localisation of the hippocampal response.....	59
3.8	Intravenous v. intrahippocampal l-propranolol.....	59
	TABLE 1.....	60
3.9	Intrahippocampal injection of timolol, atenolol and isoprenaline.....	61
3.10	Icv injection of β -blockers and adrenaline.....	61
3.11	Icv v. intravenous atenolol on the response to icv adrenaline.....	62
3.12	Further analysis of the responses to icv β -blockers and adrenaline.....	62
3.13	Intravenous injections of ICI 118551 and adrenaline.....	63
3.14	Icv injections of phentolamine, ICI 118551 and adrenaline.....	63
3.15	Intravenous phenylephrine and icv phentolamine.....	64
3.16	Intravenous hexamethonium and vasopressin antagonist on the response to icv adrenaline.....	64

3.17	Icv 118551 on the response to icv noradrenaline and phenylephrine.....	64
3.18	Electrical stimulation in the rat CNS.....	65
3.19	Icv β -blockers on the pressor responses to central stimulation.....	65
	TABLE 2.....	66
3.20	Electrical stimulation in the cat CNS.....	67
3.21	Third ventricle infusion of dl-propranolol on cardiovascular response to ansa lenticularis stimulation.....	67
3.22	Intravenous dl-propranolol on the responses to ansa lenticularis stimulation.....	69
3.23	Intravenous and third ventricle dl-propranolol on resting blood pressure and heart rate.....	69
	FIGURES 1-42	70 et seq.
Chapter 4	DISCUSSION	118
4.1	Resting blood pressure and heart rate of anaesthetised rats.....	119
4.2	Icv injection of β -blockers.....	119
4.3	Intrahippocampal injection of β -blockers.....	123
4.4	Icv injection of β -blockers and adrenaline.....	126
4.5	Icv β -blockers and electrical stimulation in the rat CNS.....	132

4.6 Icv β -blockers and electrical
stimulation in the cat CNS.....135

4.7 General conclusions.....137

4.8 Addendum: Conscious v.
anaesthetised preparations.....139

REFERENCES.....145 et seq.

APPENDIX.....167 et seq.

INTRODUCTION

Chapter 1

1.1 β -adrenoceptor blockers - an historical note

β -adrenoceptor blocking drugs or, more commonly, β -blockers have been used for many years in the clinical management of essential or primary hypertension. The first β -blocker, dichloroisoprenaline, was synthesised in 1958 during the search for a long-acting bronchodilator. However, in addition to having marked intrinsic sympathomimetic (partial agonist) activity, dichloroisoprenaline was also found to block the inhibitory effects of adrenaline and isoprenaline in a variety of preparations (Powell & Slater, 1958). Shortly afterwards pronethalol was synthesised and was demonstrated to suppress the effects of sympathomimetic amines and sympathetic nerve stimulation on the heart, but with less potent partial agonist effects (Black & Stephenson, 1962). Unfortunately, pronethalol possessed carcinogenic activity in mice. The next β -blocker to be developed was propranolol which, as well as being more active than pronethalol, did not display carcinogenic activity (Black, Duncan & Shanks, 1965).

One of the first reports on the blood pressure lowering action of propranolol in man was that of Prichard & Gillam (1964). These findings were to be amply confirmed during the next few years. By the early 1970s propranolol was firmly established as an antihypertensive drug and there are currently more than eleven β -blockers listed in the British National Formulary, although the number of compounds of known β -blocking capability is, of course, much higher.

1.2 Characteristics of primary hypertension

Although a detailed discussion of the haemodynamic alterations which accompany primary hypertension is not pertinent to this thesis, a knowledge of the major changes is relevant to the understanding of

how β -blockers may lower blood pressure (Sections 1.3-1.5).

Primary hypertension refers to the disease state in which the blood pressure is elevated through no apparent reason (Cf. pheochromocytoma, aortic coarctation and various forms of kidney disease). In its early phase in man the disease is characterised by an intermittently elevated cardiac output with little change in total peripheral resistance (so-called labile, or borderline hypertension). As the hypertension develops peripheral resistance progressively increases while cardiac output usually remains normal.

For a thorough review of the haemodynamic findings in hypertension the reader is directed to Frohlich (1977).

1.3 Haemodynamic profile of β -blocker-induced hypotension

The most obvious reaction to intravenously injected propranolol in man and animals is the fall in heart rate due to competitive blockade of cardiac β_1 -adrenoceptors. The extent of the reduction is variable, depending as it does on the level of sympathetic activity at the time of the injection. A fall in cardiac output parallels the decrease in heart rate. In hypertensive man (Tarazi & Dustan, 1972) and conscious animals (for example, spontaneously hypertensive rats - Smits et al, 1979) the reduction in cardiac output is met by an initial reflex increase in total peripheral resistance (TPR), with the nett result that no change in blood pressure is observed. However, after 3-12 hours in man (Galloway et al, 1976; Fitzgerald et al, 1979) the initially raised TPR begins to decline while cardiac output remains depressed, with the consequence that blood pressure falls. A similar sequence of events has been observed in the spontaneously hypertensive

rat (Smits et al, 1979), although it has generally been proved difficult to demonstrate the antihypertensive effect of β -blockers in many animal species.

The cause(s) of the initial elevation of TPR and its subsequent reduction are the source of much controversy. The adrenal cortex has been implicated by Nijkamp et al (1979) for the failure to demonstrate the hypotensive effect of propranolol in conscious spontaneously hypertensive rats. The latter group did not observe a fall in blood pressure after subcutaneous propranolol in either intact or adrenal demedullated animals. However, propranolol elicited a hypotension after bilateral adrenalectomy, an effect which was abolished by concurrent treatment with corticosterone. Alternatively, Sugawara et al (1980), using conscious normotensive rats, concluded that adrenal medullary catecholamine secretion was the cause of the masking of the hypotensive response to pindolol and propranolol. It seems likely that the initial elevation of TPR is due to a variety of factors (including adrenal catecholamines, adrenal steroids and enhanced activity of the sympathetic innervation to the vasculature) and probably represents a homeostatic reflex to counteract the initial cardiovascular effects of cardiac β -blockade.

It has been shown in man that the secondary fall in TPR is necessary for the expression of the hypotensive response to propranolol, since it is not observed in the proportion of hypertensive patients who do not respond to β -blocker therapy (Tarazi & Dustan, 1972). The various mechanisms which have been postulated to account for this fall are discussed in the following Section (1.4).

1.4 Potential mechanisms of β -blocker-induced hypotension

Despite much investigation into how β -blockers lower blood pressure none of the proposed mechanisms of action, of which 7 are discussed in the present Section, is entirely satisfactory. Although the β -blocking drugs as a group display considerable differences in their properties (e.g., β_1 -adrenoceptor selectivity, membrane stabilising activity and partial agonist activity), it is generally accepted that the prerequisite for antihypertensive activity is blockade of β -adrenoceptors, since all β -blockers lower blood pressure in man.

Reduction of cardiac output

In man cardiac output is lowered immediately by intravenous propranolol (Ulrych et al, 1968) while blood pressure remains unchanged. Decreased cardiac output is also associated with chronic β -blocker therapy and occurs some time before any lowering of blood pressure is seen (Tarazi & Dustan, 1972). That the decreased cardiac output is unlikely to represent the prime mechanism of action of β -blockers is suggested by the following observations: firstly, Tarazi & Dustan (1972) showed that patients who did not respond to β -blockade by a lowering of blood pressure still experienced significant decreases in cardiac output of similar magnitude to those seen in the responders and, secondly, β -blockers which possess partial agonist activity (such as practolol and pindolol) are effective antihypertensives but only lower cardiac output to a limited extent. It is likely that chronic cardiac β -blockade may reduce the elevations in cardiac output resulting from raised sympathetic activity associated with, say, emotional stress, but whether this is of any consequence in the antihypertensive action of

β -blockers remains to be investigated.

Inhibition of renin secretion

The proteolytic enzyme renin is secreted by the kidney in response to at least 3 separate stimuli - decreased intra-arteriolar pressure at the level of the juxtaglomerular apparatus, a reduced concentration of Na^+ in the macula densa segment of the distal tubule, and sympathetic stimulation. The latter is mediated both by way of increased circulating catecholamines and by way of the renal sympathetic nerves (Aoi et al, 1976). The effects of sympathetic stimulation on renin secretion appear to be mediated by intrarenal β -adrenoceptors, since catecholamine- and renal nerve stimulation-induced renin release can be blocked by propranolol (Taher et al, 1976). In vitro studies using kidney slices and renal cell suspensions have demonstrated that catecholamine-induced renin release is blocked by l-propranolol, but is unaffected by d-propranolol (Weinberger et al, 1975).

Following its release into the blood renin acts on the α_2 globulin fraction of the plasma proteins to produce the physiologically inactive angiotensin I. This in turn is converted to the active angiotensin II by an enzyme found mostly in the lungs. Angiotensin II is the most potent naturally occurring vasoconstrictor known, producing vasoconstriction and a rise in systolic and diastolic blood pressure.

A number of clinical investigators have failed to observe a correlation between plasma renin activity and the hypotensive effects of propranolol (Morgan et al, 1975; Amery et al, 1976). Furthermore, it has been shown that higher doses of propranolol than are needed to reduce plasma renin activity are required to produce an antihypertensive response (Michelakis & McAllister, 1972). β -blockers with partial

agonist activity (e.g., pindolol) may even elevate plasma renin (Stokes et al, 1975).

Therefore, while inhibition of renin secretion may be an important mode of action of β -blockers in the small proportion of hypertensives characterised by a high plasma renin activity, it seems unlikely that this represents the primary mechanism in the majority of cases.

Presynaptic inhibition of sympathetic transmission

Evidence has accumulated for the existence of presynaptic β -adrenoceptors the stimulation of which by neuronally released noradrenaline facilitates the release of further transmitter. These receptors have been demonstrated in isolated, sympathetically innervated guinea-pig atria (Adler-Graschinsky & Langer, 1975) and isolated human omental arteries and veins (Stjärne & Brundin, 1976). The latter authors concluded that these receptors were of the β_2 -subtype.

It is possible, therefore, that β -blockers may lead to a reduced availability of noradrenaline in the synaptic cleft in vivo, partly as a result of blockade of facilitatory presynaptic β -adrenoceptors and partly as a result of unopposed feedback inhibition of transmitter release by the well-documented presynaptic α -adrenoceptors (Langer, 1977). While the idea seems attractive it remains to be seen whether these receptors serve a physiological function or are merely an experimental oddity. Furthermore, if the receptors are of the β_2 -subtype then β_1 -selective blockers (which are effective antihypertensives) would exert minimal blockade.

Reduced enzymatic activity in sympathetic ganglia

Raine & Chubb (1977) demonstrated in rabbits the effect of chronic subcutaneous dosing with dl-propranolol (8 mg/kg/day) on the levels of the noradrenaline-synthesising enzymes tyrosine hydroxylase and dopamine β -hydroxylase in the superior cervical ganglion. After 6-24 days treatment the activities of both these enzymes were reduced, the d-isomer of propranolol being ineffective. Equipotent doses of metoprolol, acebutolol and practolol also reduced enzyme activities. It is likely, therefore, that noradrenaline available for neurotransmission is also reduced since tyrosine hydroxylase is the rate-limiting enzyme in its synthesis.

The crucial question here is whether the decreases in the enzyme activities reflect an action on the ganglion directly or whether they are mediated by a reduction in sympathetic outflow from the central nervous system, perhaps subsequent to blockade of central β -adrenoceptors. In this respect it is interesting to note that denervation of the ganglia for 12 days produced similar falls in enzyme activities (Raine & Chubb, 1977). The cardioselective β -blockers metoprolol, acebutolol and practolol are known only to enter the central nervous system poorly (see Section 1.5) but were nearly as effective as propranolol in the above study. However, after chronic (12 days) dosing it is possible that these β -blockers may have achieved the required steady-state concentration in the brain. The mechanism of a possible direct effect of the β -blockers on the ganglion is unknown but may be related to blockade of presynaptic β -adrenoceptors (see above). Finally, it is possible that the β -blockers may reduce autonomic afferent traffic by an action in the periphery. In turn, this may lead to a decrease in efferent sympathetic activity and so account for the enzyme changes seen in the ganglia.

Restoration of vascular relaxation sensitivity

Following the observations that vascular β -adrenoceptor sensitivity seems to be impaired in hypertension (Triner et al, 1975; Cohen & Berkowitz, 1976), Amer (1975) suggested that β -blockers may act by reversing this desensitisation. The decreased β -adrenoceptor sensitivity may arise from continual interaction with the receptors by endogenous agonists, since a reduced β -adrenoceptor sensitivity has been observed in the heart and vessels of acute, neurogenically hypertensive rats (Amer et al, 1975) in which sympathetic tone is inappropriately high.

Vascular smooth muscle is responsive to a variety of vasodilatory agents including β -adrenoceptor agonists, histamine, PGE₂, 5-hydroxytryptamine and adenosine, and in each case the response is mediated by cyclic AMP (Amer, 1977). It is also known that when a cyclic AMP-mediated response is maximally stimulated by one agonist (e.g., adrenaline) no additional effect is seen with a second agonist (e.g., histamine) (Robison et al, 1971). Amer (1977) postulated that if the source of relaxation subsensitivity lay in a reduced responsiveness of a proposed membrane-bound coupler common to all the vasodilator agonists then removal of the continual stimulus causing the subsensitivity (e.g., circulating adrenaline) would re-establish the vascular relaxation sensitivity to other circulating vasodilators.

The above theory is no less plausible than any of the others advanced in this and the next Section and merits further investigation.

An effect on baroreceptor reflex sensitivity

It has been suggested that propranolol increases baroreceptor reflex sensitivity both in normotensive (Pickering et al, 1972) and

hypertensive (Takeshita et al, 1978) subjects, such that pressor responses would be buffered at lower pressures. However, Simon et al (1977) and Krediet & Dunning (1979) failed to confirm these results in hypertensive patients. In conscious spontaneously hypertensive and normotensive rats Smits et al (1980) failed to observe an effect of acute intravenous administration of propranolol (5 mg/kg) on baroreceptor reflex sensitivity. Watson et al (1979) found a significantly increased baroreflex sensitivity in hypertensive patients (<40 years old) following chronic β -blocker therapy but not after acute treatment. Furthermore, they could not correlate the falls in blood pressure after chronic treatment with the alterations in baroreceptor reflex sensitivity.

Clearly, data on this matter are conflicting and further experimentation is required to clarify the issue. It will also be important to discriminate between an action at the level of the baroreceptors and an action on the baroreflex integrative mechanisms in the central nervous system.

A central nervous system effect

The present study was undertaken to investigate possible central effects of β -blockers on blood pressure and, because of the fundamental relevance of this issue, the question of an action within the central nervous system will be considered separately in the following Section (1.5).

1.5 The hypotensive action of β -blockers - an effect within the CNS ?

The failure of investigators to confirm a primary peripheral site of action of β -adrenoceptor blocking drugs in lowering blood pressure has led to studies of a possible central nervous system (CNS) involvement. Various hypotheses have been put forward to explain how this may be achieved - for example, an attenuation of sympathetic drive to the vasculature, a potentiation of parasympathetic outflow, a hormonal effect (for example, on vasopressin-elaborating neurones in the hypothalamus) or an enhancement of cardiovascular 'buffer' reflexes.

In this Section I wish to discuss firstly, the entry of β -blockers into the brain and secondly, the evidence for and against an action of these drugs within the CNS. The central effects on blood pressure of the β -adrenergic agonist, isoprenaline, are covered in the following Section (1.6).

Brain penetration of β -blockers

Before entertaining the idea of a central hypotensive action of β -blockers it is crucial to establish that these drugs actually enter the brain under normal physiological conditions.

It has long been known that a number of substances which are found in the blood do not appear in the cerebrospinal fluid (CSF). To explain this phenomenon it has been necessary to postulate a barrier to these materials interposed between the blood and the CNS - the so-called blood-brain barrier (for reviews see: Oldendorf, 1974; Bradbury, 1979). Briefly, the barrier restricts the passage of ions and the protein-bound fraction of a compound from gaining access to the CNS. The rate of entry of β -blockers, for example, would therefore

depend most closely on the lipid solubility of the non-protein-bound unionised fraction of the substance. In other words, the 3 factors governing the extent and rate of penetration of a drug into the CNS are lipid solubility, degree of protein binding, and the drug's pK_a .

A variety of β -blockers have been demonstrated to enter the CNS of animals and man to greater or lesser extents. For example, following intravenous injection of radiolabelled propranolol, oxprenolol, practolol and atenolol in rats, Day et al (1977) found brain:blood ratios of these compounds of 8.37, 3.26, 0.18 and 0.054, respectively. These data are consistent with the degrees of lipophilicity of the drugs (Wiethold et al, 1973). Bianchetti et al (1980) found that after intravenous injection in rats propranolol was rapidly distributed to various brain areas. Interestingly, the distribution profile closely followed the level of vascularisation of the brain, cortex containing the greatest amounts after 30 minutes, followed by hippocampus, amygdala, hypothalamus and medulla. The latter observation may indicate that some of the drug may have been present in blood trapped in the brain tissue and would not reflect specific uptake into these brain areas. Further experiments in which the brains are flushed with saline prior to assay would be required to establish the contribution of drug in entrapped blood.

In rats, Garvey & Ram (1975a) demonstrated the appearance of both propranolol and pindolol in the limbic system after 14 days oral or subcutaneous administration. Their finding that propranolol was concentrated in the hippocampus while pindolol was concentrated in the septum may reflect the different physicochemical characteristics of the drugs as well as differences in vascularisation of the brain areas. Here again, the brain was not cleared of blood prior to assay.

Evidence for the CNS penetration of β -blockers in man is two-fold. Firstly, Taylor et al (1981) found that after oral dosing of propranolol, pindolol and atenolol, all 3 compounds appeared in lumbar CSF. Similarly, Cruickshank et al (1980) noted the presence of propranolol, metoprolol and atenolol in brain and lumbar CSF of neurosurgical patients following oral administration for 3-22 days. Secondly, the incidence, albeit low, of CNS-related side-effects reported in patients on β -blocker therapy. These include depression, hallucinations, confusion and vivid dreams.

Thus, there is good evidence that β -blocking drugs are able to gain access to the brain. Once in the CNS these drugs probably interact with β -adrenoceptors. The major question, however, is whether blockade of these central adrenoceptors is responsible, at least in part, for the observed hypotensive action of the β -blocking drugs.

β -blockade, hypotensive activity and the CNS

Many mechanisms have been proposed to explain the antihypertensive action of the β -blocking drugs, and the most popular of these have been discussed in Section 1.4. In the present Section I will discuss the evidence for a site of action of these compounds within the CNS.

The stimulus to the search for a CNS site of action of β -blockers was provided by the observation of the centrally-mediated hypotensive activity of clonidine (Boissier et al, 1968), the rationale being that if central α -adrenoceptor stimulation can lower blood pressure then perhaps central β -adrenoceptor blockade would result in unopposed α -adrenoceptor-mediated effects. This schema is clearly an oversimplification, but at least it provides a conceptual framework upon which experiments may be based.

For ease of discussion I will consider separately the evidence for a central hypotensive action of β -blockers in dog, cat, rabbit and rat, respectively.

Dog

In 1971 Stern et al, using anaesthetised dogs, reported that dl-propranolol produced a lowering of blood pressure following intra-vertebral artery injection and they concluded that the hypotension was due to an action of the propranolol in the CNS. Similarly, Srivastava et al (1973) obtained prolonged depressor and bradycardic responses after injection of dl-propranolol into the lateral cerebral ventricle (icv) of anaesthetised dogs. However, the latter workers also noted an initial short-lived pressor response with associated tachycardia which they attributed to a centrally-mediated release of adrenal catecholamines, since both spinal transection at C₂ or adrenalectomy abolished these responses. Spinal transection also abolished the prolonged depressor and bradycardic responses. The latter observation does not provide conclusive evidence for a central action of propranolol since one would expect the animals to be in a state of spinal shock (see Liddell, 1934), a condition partly characterised by a drop in blood pressure and heart rate. If, as demonstrated by Anderson et al (1977) in rabbits, the propranolol was leaking out of the CNS and exerting its hypotensive effects by an action directly on the heart, then one might expect a minimal effect in the spinalectomised animals since cardiac sympathetic tone would be abolished.

In anaesthetised dogs Privitera et al (1979) demonstrated dose-dependent decreases in plasma renin activity and blood pressure after intracisternally injected dl-propranolol, an effect not mimicked by intravenous injection of identical doses. Moreover, acute renal

denervation abolished the renin-suppressing action of intracisternal propranolol, an effect one would not expect if it were due to a direct action of propranolol on the kidney following leakage from the CSF into the systemic circulation. However, both d- and l-propranolol injected intracisternally significantly lowered plasma renin activity and arterial pressure to a similar degree. Since both isomers possess equivalent local anaesthetic potencies while the d-isomer has about 1/100th the β -blocking potency of the l-isomer (Barrett & Cullum, 1968), the responses do not appear to be mediated by central β -blockade.

Montastruc & Montastruc (1980) investigated the central effects of propranolol on blood pressure in anaesthetised dogs which had been made hypertensive by sectioning of the sino-aortic buffer nerves. In this model they found that intracisternally injected propranolol decreased both the rise in blood pressure and the tachycardia induced by deafferentation, but that this protective effect was abolished by pretreatment with intracisternal 6-hydroxydopamine, a neurotoxin which produces selective destruction of adrenergic nerve terminals. However, this group only used one dose of dl-propranolol and failed to investigate the effects of the d- and l-isomers so that meaningful conclusions are difficult to draw.

An interesting observation was sketchily reported by Bogaert & Schepper (1979) in anaesthetised 'debuffered' dogs. In such animals electrical stimulation of the paraventricular nucleus of the hypothalamus led to a hypotension and bradycardia which was enhanced by prior injection of propranolol into this area. Again, whether this effect was due to β -blockade or to some ancillary property of propranolol was not investigated.

Cat

In anaesthetised cats icv dl-propranolol produced a hypotension and bradycardia (Kelliher & Buckley, 1970). However, d-propranolol elicited a similar response and so it is unlikely that the response to the racemate was due to β -adrenoceptor blockade.

Using anaesthetised cats, Share (1973) investigated the effects of icv dl-propranolol and sotalol (MJ 1999) on directly (electrical of the dorsal medullary reticular formation) and reflexly (bilateral electrical stimulation of the cut central ends of the ulnar nerves) induced pressor and tachycardic responses. While having no effect on the pressor responses, the β -blockers significantly inhibited the rise in heart rate following both types of stimulation. The effect was apparently not mediated by blockade of cardiac β -adrenoceptors by 'leaked' β -blocker since the tachycardic response to intravenous adrenaline was not affected. Sotalol, unlike propranolol, does not have significant membrane stabilising activity and it is therefore possible that central β -blockade was responsible for the observed effects.

Day & Roach (1974b), using conscious cats, investigated the effects on the cardiovascular system of a selection of centrally injected β -blocking agents. Practolol, dl-propranolol, l-propranolol (but not d-propranolol), dl-alprenolol (but not d-alprenolol), pindolol, sotalol, ICI 66082 (atenolol) and oxprenolol all produced sustained falls in blood pressure and heart rate following icv injection. A short-lived pressor response and tachycardia preceded the falls except following ICI 66082 and this was attributed to a membrane stabilising action since d-propranolol, d-alprenolol, procaine and lignocaine all evoked the initial increases but failed to elicit the

subsequent depressor responses and bradycardia. That the depressor and bradycardic responses were not mediated by an action of the β -blockers in the periphery following leakage from the CSF was suggested by the lack of alteration of the responses to intravenous isoprenaline in these animals.

Offerhaus & Van Zwieten (1974) compared the effects of the isomers of propranolol and alprenolol following injection into either a vertebral artery or peripheral vein of the anaesthetised cat. They found that dl- and d-propranolol could produce hypotensive responses of similar magnitude irrespective of the route of administration. On the other hand, l-, dl- and d-alprenolol always produced a significantly larger hypotension upon intravertebral artery injection. The conclusions were firstly, that the response to alprenolol had a marked central component whereas that to propranolol had not and secondly, that the blood pressure lowering action of β -blockers in cats was probably independent of β -blockade, since the d-isomers of both drugs were active hypotensives.

Garvey & Ram (1975b) investigated the effects on blood pressure and heart rate of intrahippocampal injections of propranolol in the anaesthetised cat. Propranolol administered in this way elicited dose-dependent reductions of blood pressure and heart rate. The ganglion blocker, hexamethonium, abolished these changes, but this may be explained by the lower initial values of blood pressure and heart rate. These investigators failed to observe any significant changes in blood pressure and heart rate following icv injections of dl-propranolol in these animals.

Klevans et al (1976), using anaesthetised cats, compared the effects of icv and intravenous injections of dl-sotalol, dl-pindolol,

dl- and d-propranolol on the blood pressure and renal sympathetic nerve discharge (reflexly evoked by electrical stimulation of the cut central end of the sciatic nerve). They found that dl-pindolol, dl- and d-propranolol, but not dl-sotalol, reduced both blood pressure and renal nerve evoked potentials following either icv or intravenous injection, but that the reductions were much greater after the central injections. The characteristic common to the 3 active compounds is membrane stabilising activity and it would therefore appear that although an action on central 'sympathetic structures' was demonstrated, it was independent of β -adrenoceptor blockade.

Sharma et al (1979) have studied the effects of microionophoretically applied β -blockers on the firing rates of medullary cardiovascular neurones in anaesthetised mid-collicular decerebrate cats. The neurones were identified by their firing rate responses to intravenous noradrenaline, a decreased rate of excitatory neurones and an enhanced firing rate of inhibitory neurones. A non-cardiovascular neurone was identified if its firing rate remained unchanged during the pressor response to noradrenaline. They found that ionophoretically applied dl-propranolol and dl-sotalol reduced the spontaneous firing rates of excitatory cardiovascular neurones but had no effects on the firing rates of inhibitory and non-cardiovascular neurones. They concluded that: "While these results cannot exclude the possibility of a peripheral influence in β -adrenergic blocker-induced hypotension, it is concluded that the major hypotensive effect is a result of their action on β -adrenergic receptors of bulbar cardiovascular neurones." Clearly, these conclusions are untenable for 2 major reasons - firstly, the identification of β -adrenoceptors responsive to ionophoresed β -blockers on central neurones in a small region of the medulla does not necessarily imply a hypotensive role for them and

secondly, the conclusions exclude the potential contribution of cardiovascular neurones elsewhere in the medulla and in other regions of the CNS (for example, spinal cord and hypothalamus). However, further studies of this type may lead to a better understanding of the functions of β -adrenoceptors on central cardiovascular neurones.

Philippu & Kittel (1977) and Philippu & Stroehl (1978), using anaesthetised cats, analysed the effects of β -blockers superfused through the posterior hypothalamus by means of a push-pull cannula (electrically insulated except for the tip) on the pressor response and tachycardia produced by electrical stimulation through the tip of the cannula. They found that atenolol, practolol and metoprolol (β_1 -selective), propranolol and sotalol (non-selective), and butoxamine (β_2 -selective) caused a dose-dependent inhibition of the pressor and tachycardic responses. Both d-propranolol and an equipotent local anaesthetic concentration of procaine were ineffective in this respect. Conversely, hypothalamic superfusion with isoprenaline produced a dose-dependent enhancement of the pressor responses to electrical stimulation. Thus, both β_1 - and β_2 -adrenoceptors were implicated in these studies and suggests a possible hypothalamic target for the hypotensive action of β -blockers.

Rabbit

In conscious rabbits Reid et al (1974) provided evidence of a central antihypertensive effect of propranolol. Icv injections of l- and dl-propranolol (500 μ g) produced an initial rise in blood pressure followed by a prolonged fall, the hypotensive response to the l-isomer being greater. Central administration of an identical dose of d-propranolol only produced the initial pressor response, as did icv procaine. Since the intravenous injection of

l-propranolol (500 µg) did not affect blood pressure, the authors concluded that propranolol can lower blood pressure by an action within the CNS.

Anderson et al (1977) obtained a similar pattern of response following icv injection of dl-propranolol (500 µg) in the conscious rabbit. However, in contrast to Reid et al (1974), the same dose injected intravenously elicited a hypotension which was greater than that after icv injection. This group also demonstrated rapid leakage of propranolol from the CSF into the bloodstream, an icv injected dose achieving a plasma concentration after 10 minutes of 80% of the level reached after giving the same dose intravenously. Also, after icv injection there was significant blockade of cardiac β -adrenoceptors for at least 2 hours, as determined from the degree of attenuation of isoprenaline-induced tachycardia. This investigation does not exclude a central hypotensive action of propranolol but demonstrates one of the major problems associated with icv injection - namely, attempting to discriminate central from systemic actions, especially where one action does not greatly predominate over the other. The reader interested in the mechanisms by which substances may leave the CSF and enter the bloodstream should consult Rothman et al (1961) and Schanker (1962).

Lewis & Haeusler (1975) investigated the effects of intravenous propranolol on splanchnic nerve discharge and blood pressure in the conscious rabbit. Both these parameters were reduced by dl- but not by d-propranolol. Moreover, the reductions paralleled one another in time course. The authors concluded that the reduction of sympathetic activity was mediated by blockade of central β -adrenoceptors, since the splanchnic is a preganglionic nerve. However, some criticism

has been levelled at this conclusion as it is possible that the propranolol was acting peripherally on the afferent limb of this autonomic response to modify input to the CNS. Some evidence for such an effect in anaesthetised cats has been provided by Scott (1981), who investigated the effect of intravenous atenolol on efferent discharges in the lumbar trunk and renal nerves. After atenolol, blood pressure, heart rate and sympathetic efferent activity were all significantly reduced. Scott concluded that the atenolol had effected this response by an action outside the CNS, since atenolol has a low lipid solubility and therefore is not likely to cross the blood-brain barrier to any great extent (Barrett, 1977). Unfortunately, the measurements in these experiments were made from nerves containing both pre- and postganglionic fibres and it is therefore impossible to rule out an action of the atenolol at the ganglionic level. It would be useful if these experiments were to be repeated in conscious rabbits under similar conditions to those used by Lewis & Haeusler (1975). It is interesting to note that Lewis (1976) obtained a decrease in blood pressure but an increase in sympathetic efferent activity following intravenous injection of another β -blocker having a low lipid solubility, practolol, in the conscious rabbit.

In conscious rabbits Korner et al (1980) showed that high plasma concentrations of propranolol lowered the threshold pressure for inhibiting renal sympathetic nerve activity. (Arterial pressure was manipulated by means of balloons placed around the aorta and inferior vena cava and the effect of different levels of pressure on renal sympathetic nerve activity was studied. With mean arterial pressure as abscissa and nerve activity as ordinate the resulting curve has a negatively-sloped sigmoidal shape. This curve was shifted to the left by propranolol such that at any given pressure the renal nerve activity

was less than that before the drug). Similar plasma concentrations of propranolol had little effect on aortic nerve baroreceptor activity. Thus, the authors concluded that the propranolol was acting centrally to 'reset' the renal sympathetic baroreflex. A similar 'resetting' of baroreflex properties has been demonstrated with the centrally-acting antihypertensive, clonidine (Dorward & Korner, 1978).

Rat

Lavy & Stern (1970), using anaesthetised rats, reported that the direct application of propranolol (1000 µg) in powdered form into various CNS structures elicited a decrease in heart rate and that this effect was most powerfully evoked from the anterior hypothalamus and reticular formation. However, this group made no attempt to evaluate the extent of drug leakage into the systemic circulation and consequently, no firm conclusions may be reached.

Intracisternally administered propranolol produced dose-related decreases in heart rate in anaesthetised rats (Ito & Schanberg, 1974). At lower doses intracisternal propranolol produced a pressor response but this was converted to a depressor response at larger doses. The pressor response was antagonised by subsequent intracisternal injection of isoprenaline but potentiated by similarly administered noradrenaline. Isoprenaline alone caused a decrease in blood pressure while noradrenaline produced a transient increase. Whether these findings demonstrate a pharmacological interaction of the drugs at central adrenoceptors remains unknown. Moreover, neither the effects of d-propranolol nor the contribution of 'leaked' propranolol to the responses were investigated.

Sweet & Wenger (1976) studied the effects of centrally injected

propranolol in the conscious spontaneously hypertensive rat. Both dl- and d-propranolol (100 µg) injected icv produced a transient increase in arterial pressure which was followed by a significant lowering of blood pressure at 24 hours. Neither systemically injected propranolol nor icv injected procaine (100 µg) mimicked these responses. Before assuming, as the authors did, that the hypotension produced by icv propranolol was independent of β -blockade and membrane stabilising activity, it is important to realise that procaine is some 3-times less potent than propranolol as a local anaesthetic, at least in the isolated frog nerve preparation (Barrett & Cullum, 1968). Indeed, Sweet & Wenger did note a decrease in arterial pressure after icv procaine but this did not achieve statistical significance. If the centrally-mediated hypotension produced by dl- and d-propranolol was dependent on membrane stabilising activity, then this result would be in line with that of Kelliher & Buckley (1970) in the anaesthetised cat.

Kleinrok & Ksiazek (1977) investigated the effects of a variety of centrally injected β -blocking agents on the hypertension produced by icv noradrenaline in the anaesthetised rat. Pretreatment with propranolol, alprenolol, sotalol and practolol abolished the noradrenaline-induced pressor response. Since both practolol and sotalol lack membrane stabilising activity it is possible that blockade of central β -adrenoceptors was responsible for the effect. The β -blockers themselves did not affect blood pressure. Leakage of the β -blockers and noradrenaline into the systemic circulation was not examined in this study.

Ram et al (1977) implicated the hippocampus in the hypotensive response to orally administered propranolol in conscious rats. Chronic oral administration of propranolol to intact rats produced a significant

decrease in systolic blood pressure. However, in hippocampal-lesioned animals similar treatment produced significant elevations of blood pressure. It is not clear from the paper exactly how much of the hippocampus was ablated, but caution should be exercised in the interpretation of results from experiments where gross damage is inflicted in the CNS, especially in a structure such as the hippocampus, which is known to have important behavioural and endocrine functions.

Wepierre et al (1978), using anaesthetised rats, examined the blood pressure responses to icv pindolol, propranolol, practolol, INPEA and alprenolol. All the drugs except INPEA produced dose-related falls in blood pressure. That this effect was centrally-mediated was suggested by the relatively weak hypotensive action of these β -blockers following intravenous injection. The effectiveness of practolol suggests that the responses were not due to the membrane stabilising actions of the other drugs.

In a later study by the same group (Cohen et al, 1979), d- and l-propranolol and pindolol were shown to exert hypotensive actions following icv injection in anaesthetised rats. However, d-propranolol was less active than the other 2 compounds.

Lack of a central hypotensive action of propranolol in the conscious spontaneously hypertensive rat was reported by Smits et al (1980a). The latter group established that after icv infusion of propranolol for 5 days (by means of osmotic minipumps), brain concentrations reached values that were approximately 100-fold higher than those achieved after subcutaneous infusion of equal doses. Since upon icv infusion the dose of propranolol needed for a blood pressure lowering effect was the same as that needed for a subcutaneous infusion, the authors reasoned that the antihypertensive effect of

propranolol was not caused by an action of the drug within the CNS.

Recently, Allott et al (1982) investigated in anaesthetised rats the effects of β -blockers (injected through a stainless steel cannula electrically insulated except for the tip) on the pressor response to electrical stimulation of an area immediately dorsal to the posterior hypothalamus. They found that l-, dl- and d-propranolol inhibited the pressor responses but that the β_1 -selective blocker, atenolol, did not. The l-isomer was more active than the racemate but only about 4-times more potent than the d-isomer. These results therefore suggest a contribution of both β_2 -blockade and membrane stabilising activity to the inhibition of the responses, since d-propranolol has about 1/100th the β -blocking potency of the l-isomer (Barrett & Cullum, 1968).

Conclusion

It is apparent from the foregoing that the general findings after central injection of β -blockers are hypotension and bradycardia, although whether the effects are due to blockade at the β -adrenoceptor or to a non-specific membrane stabilising action of the drugs is not entirely clear. To confound the issue further, leakage of drug from CSF to the systemic circulation is a constant problem and not all investigators have designed experiments in which peripheral effects may be distinguished from central effects. It is also evident that the cardiovascular effects of centrally administered β -blockers are weak compared to those of, say, the powerful centrally acting antihypertensive α -adrenergic agonist, clonidine (Kobinger, 1978).

The variability in results between groups is sometimes puzzling, although generally this may be explained by the use of conscious or anaesthetised animals, choice of anaesthetic, route of administration

(for example, intracisternal, icv, third ventricle) and even the location of an injection within a single ventricle. Moreover, there are no a priori grounds for assuming that the populations of β -adrenoceptors in the various parts of the CNS are functionally homogeneous. That is, β -adrenoceptors in, say, the hypothalamus may mediate antagonistic effects on the cardiovascular system to β -adrenoceptors in the brain stem. Whether a particular response to centrally injected β -blockers is seen may thus depend on the relative activities of such functionally opposing neuronal pools which, in turn, may be dependent on the type of anaesthetic used or, in the case of unanaesthetised animals, on the level of arousal (vide infra). General anaesthetics obviously depress 'higher' brain function more than the 'lower' brain vegetative functions. It is possible, therefore, to attribute an exaggerated importance to such 'lower' brain sites.

The use of the term 'conscious' to describe an animal's condition is misleading and should be replaced by the term 'unanaesthetised'. The reason for this is that the injection of substances into the brain and CSF of such animals may lead to changes in arousal state ranging from overt sedation to hyperexcitability, such that changes in cardiovascular parameters may be secondary to the behavioural alteration and not as a direct result of an interaction of the drug with the 'cardiovascular' receptor. Rarely does one find even cursory mention of the animal's state of arousal in reports where drugs have been injected into the CSF of unanaesthetised animals.

The weak central action of β -blockers on the cardiovascular system together with their more obvious (and perhaps synergistic) systemic effects, underline the need for rigorous control of experimental design and the measurement of as many parameters of

cardiovascular function as is technically feasible. This is exemplified by Korner et al (1980) who observed a reduction of blood pressure but no change in renal sympathetic nerve activity following intravenous infusion of propranolol in unanaesthetised rabbits. Renal baroreflex curves, however, were dramatically shifted in the absence of any significant change in baroreceptor activity (see earlier).

The central effects of α - and β -adrenergic agonists and antagonists on the cardiovascular system have been reviewed by Philippu (1980).

A detailed discussion of the anatomical and physiological organisation of central cardiovascular control is not within the scope of this thesis. However, there are several excellent reviews on these topics to which the interested reader is directed: Hilton (1975), Calaresu et al (1975), Antonaccio (1977), Loewy & McKellar (1980) and Dampney (1981).

1.6 Cardiovascular effects of centrally injected isoprenaline

Studies of the cardiovascular effects of centrally injected isoprenaline have led to more variable results than those in which β -blockers have been used (Section 1.5).

In anaesthetised cats Gagnon & Melville (1967) obtained a fall in blood pressure and a tachycardia following icv injection of isoprenaline, effects which were abolished by spinal cord transection at C₂. Similar results were obtained by Toda et al (1969) in anaesthetised rabbits. Bhargava et al (1972) obtained a hypotension and tachycardia following icv injection of isoprenaline in

anaesthetised dogs. This response was blocked by the prior icv injection of either propranolol or N-isopropyl-p-nitrophenylethanolamine (INPEA). These authors therefore concluded that central β -adrenoceptors were mediators of tachycardia and hypotension. Conway & Lang (1974) obtained similar results after icv injection of isoprenaline in unanaesthetised dogs. However, in the latter study the responses were potentiated by ganglion blockade suggesting that they were probably mediated via 'leaked' isoprenaline. In anaesthetised cats and dogs Schmitt & Fenard (1971) obtained a hypotension and, in contrast to the above reports, a decrease in heart rate.

Both pressor and depressor responses to icv isoprenaline have been observed in anaesthetised dogs (R.H.Poyser, personal communication cited in Day & Roach, 1974c).

Day & Roach (1973) obtained pressor and tachycardic responses following icv injection of isoprenaline in unanaesthetised cats. That these effects were of central origin and mediated by the sympathetic nervous system was demonstrated by their abolition following either ganglion blockade or adrenergic neurone blockade. Furthermore, the responses to icv isoprenaline were abolished by prior icv injection of propranolol while the peripheral responses to intravenous isoprenaline remained unaffected, indicating that the propranolol had not leaked out of the CNS. Similar doses of icv propranolol alone elicited falls in both blood pressure and heart rate.

The above results were largely verified by a later, more extensive investigation also in unanaesthetised cats (Day & Roach, 1974a). In this study icv isoprenaline always produced a tachycardia

but had variable effects on blood pressure, although in the majority of animals (12/20) a dose-dependent increase in blood pressure was seen. Nevertheless, the responses to centrally injected isoprenaline were always abolished by prior icv injection of either dl-propranolol or dl-alprenolol. Confirmation of the central mediation of the responses was by similar means to that described by Day & Roach (1973). That the inhibition of the pressor response to icv isoprenaline by propranolol was mediated by blockade of central β -adrenoceptors was suggested by the lack of effect of d-propranolol.

In unanaesthetised rabbits Day and Roach (1974c) obtained small increases in blood pressure and tachycardia after icv isoprenaline. In contrast, Dollery et al (1973), who also used unanaesthetised rabbits, obtained a hypotension following icv isoprenaline. In the latter study no mention was made of concurrent changes in heart rate.

It is difficult to reconcile the variability in results from investigations where isoprenaline has been centrally injected with the more uniform effects obtained with centrally injected β -blockers (Section 1.5). Part of this variability will undoubtedly be due to the systemic effects of 'leaked' isoprenaline, and the final cardiovascular response may reflect a balance between central and peripheral actions. Even so, the observation in the unanaesthetised cat of both pressor and depressor responses to icv isoprenaline (Day & Roach, 1974a) serves to illustrate both the complex nature of central cardiovascular control and possibly also between-animal differences in the distribution of drug following icv injection. Also, it is apparent from microelectrophoretic studies that isoprenaline is able to stimulate both α - and β -adrenoceptors in the brain (Szabadi, 1979).

1.7 β -adrenoceptors in the CNS

In this Section I shall discuss the evidence for the presence of β -adrenoceptors in the CNS and consider the potential endogenous agonists which may interact with them.

Kakiuchi & Rall (1968) were the first to demonstrate biochemically the presence of β -adrenoceptors in the brain. They showed that an adenylate cyclase from rabbit cerebellum produced an increase in cyclic AMP when stimulated by isoprenaline. This effect was blocked by dichloroisoprenaline, a phenomenon not observed with α -adrenoceptors in the CNS which appear also to respond to stimulation by an increase in cyclic AMP (Chasin et al, 1971).

The later introduction of high-affinity radiolabelled ligands has led to more quantitative determinations of central β -adrenoceptors. For example, Bylund & Snyder (1976), using membrane preparations from rat and monkey brain, investigated the ability of β -adrenergic agonists to displace (^3H)-dihydroalprenolol. The order of potency of the agonists was isoprenaline > adrenaline \approx noradrenaline, thus satisfying the criteria for β -adrenoceptors. These authors also investigated the regional distribution of (^3H)-dihydroalprenolol binding in the rat and monkey brain. In both species binding was higher in the cerebral cortex and limbic system than in the hypothalamus, pons and medulla.

The technique of microelectrophoresis has enabled the pharmacological characterisation of β -adrenoceptors in various parts of the CNS, mainly in the rat (for review see Szabadi, 1979). Usually, noradrenaline is ionophoresed onto central neurones and the effect of β -blockers on either firing rate (extracellular recording)

or graded membrane response (intracellular) to the noradrenaline is investigated. In this way β -adrenoceptors have been identified on neurones in the brain stem, cerebellum, hypothalamus, limbic system, corpus striatum and cortex.

Although the above techniques have provided firm evidence for the presence of β -adrenoceptors in the brain, none of them casts light on their function, if any, in the central regulation of blood pressure.

Of the putative transmitters in the brain the most likely candidates for agonists at the β -adrenoceptor are noradrenaline and adrenaline, the distributions of which have been mapped by means of fluorescence histochemical and immunohistochemical methods (Ungerstedt, 1971; Hökfelt et al, 1973, 1974 - respectively). It seems unlikely that dopamine is an endogenous agonist at the β -adrenoceptor since Bylund & Snyder (1976) showed it to be at least 100-fold less potent than noradrenaline and adrenaline at inhibition of (^3H)-dihydroalprenolol binding in mammalian brain membrane preparations. A comprehensive review of the anatomy and physiology of central noradrenaline and adrenaline systems may be found in Moore & Bloom (1979).

While β -blocking drugs may be expected to interact with brain β -adrenoceptors, the possibility of an interaction of these compounds with central 5-hydroxytryptamine (5-HT) receptors has been suggested by Middlemiss et al (1977), who investigated the inhibition of (^3H)-5-HT binding by a number of β -blockers in crude synaptic membranes of rat brain. In this respect, 1-propranolol was more effective than the 5-HT antagonist, methysergide. Racemates of propranolol, alprenolol, oxprenolol and pindolol were also effective.

Least potent were d-propranolol, dl-practolol and dl-atenolol. Recently, however, Blackburn & Heapy (1982) failed to obtain an inhibition by propranolol of 5-HT-induced rat body shake behaviour. Furthermore, microelectrophoretic (Bradley & Gladman, 1981) and neurophysiological (Cox et al, 1981) studies have failed to support the suggestion that propranolol is a postsynaptic 5-HT antagonist.

1.8 Cardiovascular effects of centrally injected α -adrenergic agonists and adrenaline

Following icv injection of noradrenaline in anaesthetised dogs, McCubbin et al (1960) obtained a bradycardia and hypotension. Similarly, Nashold et al (1962) and Share & Melville (1963) obtained hypotension and bradycardia after icv injections of noradrenaline in anaesthetised cats. Day & Roach (1974a) reported falls in blood pressure and heart rate after icv injections of α -methylnoradrenaline, clonidine and noradrenaline in unanaesthetised cats. The effects were abolished by pretreatment with icv phentolamine. In anaesthetised rats the injection of noradrenaline into specific areas in the anterior hypothalamus and brain stem produced hypotension and bradycardia (Struyker Boudier et al, 1975), the greatest brain stem responses being evoked by injections into the nucleus tractus solitarii. Similar responses were obtained by De Jong et al (1975) following nucleus tractus solitarii injections of noradrenaline in anaesthetised rats. In the latter report prior injection of phentolamine into the nucleus prevented the hypotension and bradycardia produced by the subsequent injection of noradrenaline.

However, that the sole effect of centrally injected noradrenaline is not cardiovascular depression is suggested by the

following reports. Third ventricular infusions of noradrenaline have been shown to evoke pressor responses in unanaesthetised monkeys (Forsyth & Pesout, 1978). Furthermore, pretreatment with icv 6-hydroxydopamine, a chemical causing selective degeneration of catecholamine neurones (Jonsson et al, 1975), as well as exerting a hypotension and bradycardia by itself, also blocked the pressor responses to subsequent third ventricular injections of noradrenaline. Systemic responses to intravenous noradrenaline were not modified (Forsyth & Pesout, 1978).

Day et al (1980) obtained differential effects of noradrenaline depending on whether the amine was injected into the lateral cerebral ventricle or the third ventricle of the unanaesthetised cat. Thus, a low dose of noradrenaline injected into the third ventricle produced a marked pressor response, whereas the same dose injected icv had no effect. However, a higher dose of noradrenaline injected icv evoked a long-lasting hypotension.

In anaesthetised rats, Kleinrok & Ksiazek (1977) obtained only pressor responses to icv noradrenaline.

The first report of a central cardiovascular effect of adrenaline was probably that of Heller (1933) who obtained marked falls in blood pressure and heart rate following intracisternal injection in anaesthetised cats. More recently, Borkowski & Clough (1981), using unanaesthetised dogs, demonstrated a hypotension and bradycardia after icv injection of adrenaline. These responses were not modified by icv pretreatment with the α -adrenergic antagonists, phentolamine and yohimbine, but were inhibited by icv pretreatment with propranolol, atenolol and metoprolol. However,

the effects of the β -blockers themselves on blood pressure and heart rate were not reported, thus making it difficult to draw firm conclusions.

In unanaesthetised cats icv adrenaline produced variable effects on blood pressure and heart rate (Day & Roach, 1974a). However, in cats which had been pretreated with icv propranolol, adrenaline produced only a hypotension and bradycardia. After pretreatment with icv phentolamine, adrenaline produced dose-related increases in blood pressure and heart rate.

In anaesthetised rats, intracisternal injections of adrenaline elicited an initial pressor response followed by a hypotension (Ozawa & Uematsu, 1975). Struyker Boudier & Bekers (1975) obtained decreases in blood pressure and heart rate after injections of adrenaline into the anterior hypothalamus of anaesthetised rats. The hypotension was preceded by a small, but significant, increase in blood pressure but this was attributed to a peripheral action of the amine since intravenous adrenaline produced only a pressor response.

Icv adrenaline produced hypotension and bradycardia in anaesthetised rats (Borkowski & Finch, 1979) and in anaesthetised (Borkowski & Finch, 1978) and unanaesthetised (Borkowski & Finch, 1977, 1978) spontaneously hypertensive rats. In these experiments pretreatment with icv β -blockers antagonised the cardiovascular depression produced by icv adrenaline, whereas icv pretreatment with α -adrenergic antagonists was ineffective.

Thus, the general cardiovascular effects of centrally administered adrenaline appear to be hypotension and bradycardia,

at least in the rat and dog. Moreover, the ability of β -, but not α -blockers to antagonise these responses suggests a hypotensive and bradycardic function of central β -adrenoceptors in these animals.

1.9 Aims of the present study

The present study was designed to investigate further the possible role of brain β -adrenoceptors in the central regulation of blood pressure. The problem was tackled at 3 levels:

1. The effects on the cardiovascular system of β -blockers injected into the cerebral ventricle and into the brain substance of the rat;
2. The effect of centrally injected β -blockers on the cardiovascular responses to icv α - and β -adrenergic agonists in the rat;
3. The effect of centrally injected β -blockers on the cardiovascular responses to electrical stimulation in various areas of the rat and cat brain.

The first approach is that most commonly encountered in studies of this nature (see Section 1.5). However, its major limitation lies in the assumption that there is β -adrenoceptor-mediated activity during the course of the experiment and that this activity has a rôle in the maintenance of resting blood pressure and heart rate. The second and third approaches were designed to help circumvent this limitation.

MATERIALS AND METHODS

Chapter 2

2.1.1 General considerations

Each of the Sections in this Chapter has been allocated a 3 figure number. The first number refers to the Chapter while the second number denotes a major sub-division within the Chapter. The final number denotes a division within a sub-division. Thus, Sections 2.2.1 to 2.2.4, for example, are linked by virtue of the similar techniques and protocols described within them. In this first Section I shall discuss the stereotaxic technique, which has been used in most of the experiments, and the histological methods used to verify cannula and electrode placements in the animals' brains.

2.1.2 The stereotaxic technique

For the following discussion the reader should refer to Figure 1. The stereotaxic instrument consists of a rigid metal frame on which is mounted a carrier whose travel may be finely controlled in 3 planes. A cannula or electrode is clamped firmly onto the carrier and its tip located at the mid-point of the ear bars, the tips of which have been previously separated by 1mm. The cannula or electrode tip is now at stereotaxic zero and the following coordinates are recorded:

- AP (anterior-posterior plane)
- L (lateral plane)
- H (horizontal plane)

Each stereotaxic atlas has an arbitrary horizontal zero plane which differs from the horizontal (H) plane determined above. In the instance of the rat brain atlas of König & Klippel (1963) the horizontal zero plane lies 4.9mm above the interaural line when the upper incisor bar is 2.4mm below the interaural line (see below). (The interaural line is an imaginary line passing through the centre of the two ear bars).

For the cat brain atlas of Snider & Niemer (1961) the horizontal plane lies 10mm above the interaural line.

Three coordinates are taken from the stereotaxic atlas and these describe the position of most areas of the brain relative to instrument zero. (Instrument zero uses the AP and L coordinates obtained by the method described on the previous page, and the modified H coordinate). The final position of the cannula or electrode tip is then determined as follows:

$$\text{atlas coordinate} \pm \text{instrument zero coordinate} = \text{final instrument coordinate}$$

In the case of the rat, the animal is mounted in the instrument by manoeuvring the head of the animal so that the ear bars lie in the external auditory meatus of each ear. The head is then centralised within the frame by reference to the calibrations on the ear bars. The upper teeth are hooked over the incisor bar and the nose clamp gently tightened. The incisor has a vertical adjustment and its final position depends on the stereotaxic atlas being used. For the atlas of König & Klippel (1963) the incisor bar is set 2.4mm below the interaural line.

The cat stereotaxic instrument is equipped with a head-holder that has two eye bars (which are rested on the infra-orbital ridges) and two teeth bars (which are set firmly against the canine teeth). Unlike the rat instrument the cat frame allows only horizontal positioning of the animal's head.

A more detailed discussion of the stereotaxic technique may be found in Pellegrino & Cushman (1971).

2.1.3 Histological techniques

Although the stereotaxic technique allows highly accurate and reproducible electrode and cannula placements, the inevitable variation between animals requires that placements are verified following experimentation.

For the verification of icv injections in rats, 10 μl of a 1% w/v aqueous solution of Evans Blue dye were injected at the end of every fifth experiment. The ventricle is a relatively large target and verification in every animal was considered unnecessary. A lethal dose of anaesthetic (either pentobarbitone or thiobutobarbitone) was injected intravenously and the animal removed from the stereotaxic instrument. The chest was opened and a 19 gauge hypodermic needle inserted and clamped into the left ventricle. The right ventricle was cut to allow blood to leave the cardiovascular system. Twenty ml of a 0.9% w/v NaCl solution was injected into the left ventricle followed by 40 ml of 10% formol saline (9 g NaCl + 100 ml of 40% formaldehyde, made up to 1 litre with distilled water). The latter procedure enabled in vivo fixation of the brain. The brain was removed from the skull and verification of successful icv injection performed by gross dissection.

Intrahippocampal injections were verified by a similar procedure to that described above, except that only 0.4 μl of dye was injected and the brain kept for at least 4 days in 10% formol saline after removal from the skull. Verifications were performed in every other animal. Sections of 70 μm thickness were cut on a freezing microtome from a block of brain containing the injection site. Sections were examined under low-power microscopy and

compared with the appropriate coronal section in the stereotaxic atlas. An example of a section is shown in Figure 5.

Verification of electrode placements in rats is discussed in Section 2.4.4.

In cats, verification of ansa lenticularis electrode placement was achieved at the end of the experiment by passing anodal dc current (1 mA, 40 seconds) through the stimulating electrode. The resulting lesion was visualised by gross dissection following removal of the brain and fixation in 10% formol saline. Third ventricle injections were verified at the same time following the infusion of 500 μ l of a 1% w/v aqueous solution of Evans Blue dye at the end of each experiment.

2.2.1 Central injection of β -blockers in halothane anaesthetised rats

During the early stages of this study rats were anaesthetised with the gaseous anaesthetic, halothane (Fluothane, ICI plc). Male Wistar rats (University of Bath strain), weighing 140 - 170 g, were placed in a perspex chamber through which was blown a mixture of 5% halothane in oxygen. The concentration of halothane in the inspired gas was regulated by means of a Flutec III vapouriser (Cyprane Ltd) incorporated in a Boyles anaesthetic apparatus. Gas flow was always maintained at 1 litre/minute. When unconscious, the rats were removed from the chamber and placed on a heated operating table. Thereafter, open circuit anaesthesia was maintained by blowing a mixture of 1% halothane in oxygen over the animal's nose by way of a mask fashioned from a 5 ml plastic syringe. Depth of anaesthesia was adjusted by varying the concentration of halothane in the inspired gas, the range being from about 1%-2%.

The left carotid artery was catheterised with a polyethylene tube (ref: 200/300/030, Portex Ltd) connected to a physiological pressure transducer (Type 4-442, Bell & Howell Ltd), the whole unit being filled with heparinised saline (200 Units heparin/ml 0.9% w/v NaCl). The transducer was coupled to a blood pressure pre-amplifier (Devices 3552), the output of which was fed to a 2-channel pen recorder (Devices MX2) and to a heart rate conditioning unit (Devices 4521) which derived heart rate from the blood pressure pulse. The heart rate was displayed on the second channel of the pen recorder.

The left jugular vein was catheterised with a saline-filled polyethylene tube (ref: 200/300/020, Portex Ltd) to enable the intravenous injection of drugs.

After insertion of arterial and venous catheters the rat was positioned in a small animal stereotaxic instrument (DKI 900, David Kopf Instruments) on which a feedback-controlled heating blanket had been placed (C.F. Palmer Ltd). Feedback was provided by a probe located in the rat's rectum, body temperature being maintained at 37 °C. The anaesthetic mask was replaced over the animal's nose and its blood pressure allowed to stabilise before any further surgery.

The animal's skull was exposed by a dorsal midline incision extending about 15 mm back from the eyes. Underlying tissue adhering to the skull was scraped away.

2.2.2 Intracerebroventricular (icv) injection of propranolol

The injection unit of the stereotaxic instrument carried a 30 gauge stainless steel cannula to which was attached about 20 cm of polyethylene tubing. The tip of the cannula was manoeuvred to a

position on the skull directly over the area to be injected and a hole was drilled in the bone by means of a dental burr. The tough dura mater underlying the burr hole was scraped away with the blunted tip of a 23 gauge syringe needle to allow unrestricted entry of the cannula into the brain substance. The following coordinates were used to locate the tip of the cannula into the left lateral cerebral ventricle: A +3.29, L +4.4, H -0.4 mm (König & Klippel, 1963).

The polyethylene tubing and cannula were loaded with a 10 mg/ml solution of propranolol hydrochloride in saline. A 10 μ l microsyringe (Hamilton) was filled with 70% alcohol and the syringe attached to the polyethylene tubing. The cannula was lowered to the injection site and blood pressure and heart rate allowed to stabilise before commencing the injection.

The propranolol solution was injected at a rate of 1 μ l/minute until a total volume of 10 μ l had been administered. A total dose of 100 μ g of propranolol HCl was therefore contained in the injectate.

Blood pressure and heart rate were monitored for a period of 30 minutes following the injection.

The region of brain in which the propranolol was injected is shown diagrammatically in Figure 2.

Leakage of propranolol from the ventricular CSF to the systemic circulation was investigated in a separate series of experiments by comparing the heart rate response to intravenous isoprenaline (0.1 μ g) 5 minutes before and 15 minutes after the start of the icv propranolol injection.

2.2.3 Intrahippocampal injection of β -blockers

For the unilateral administration of drugs into the hippocampus a similar procedure to that described in Section 2.2.1 was carried out. However, the dose of drug was contained in 0.4 μl of saline and a 1 μl microsyringe (Hamilton) was used to inject the solution at a rate of 0.1 $\mu\text{l}/\text{minute}$. The following coordinates were used to locate the tip of the cannula in the subiculum of the dorsal hippocampus: A +1.27, L +3.1, H +1.4 mm (König & Klippel, 1963). Figure 3 shows diagrammatically the region of brain in which the drugs were injected.

2.2.4 Anatomical localisation of the responses to intrahippocampal injection of β -blocker

To investigate whether the responses to the above injections were specific to the dorsal hippocampus, injections were made in 5 brain regions at small distances away from the original site. The coordinates of these areas relative to the dorsal hippocampal injection site are given in Figure 4.

2.3.1 Icv injection of drugs in thiobutobarbitone anaesthetised rats

Male Wistar rats (Alderley Park SPF strain), weighing 200-300 g, were anaesthetised with thiobutobarbitone sodium (Inactin, BYK; 150 mg/kg i.p.). Thereafter, surgical preparation was similar to that described in Section 2.2.1. Further anaesthetic was administered as and when necessary via the intravenous catheter, although the initial dose was usually sufficient for the duration of the experiment (about 1 hour). For most of these series of experiments

an Elcomatic EM751 transducer was used to record blood pressure and this was coupled to a Devices 3552 pre-amplifier located in a Devices M19 recorder. Heart rate was derived from the blood pressure pulse using a cardiometer manufactured by ICI.

The following coordinates were used to locate the injection cannula in the left lateral cerebral ventricle: A +3.29, L +4.4, H -0.4 mm (König & Klippel, 1963).

All drugs for central injection were dissolved in an artificial CSF of the following composition (mM): NaCl 127.65, KCl 2.55, CaCl₂.2H₂O 1.26, MgCl₂.6H₂O 0.93, NaHCO₃ 23.7, NaH₂PO₄ 1.51, glucose 3.38. This recipe is a modification of that used by Merlis (1940).

2.3.2 Effect of icv β -blocker pretreatment on the response to icv adrenergic agonists

Drugs were injected according to the following schedule:

time (mins)	β -blocker icv =====		adrenergic agonist icv =====	
		↑	↑	↑
	-15	-10	0	2.5

The dose of β -blocker was contained in 10 μ l artificial CSF and injected at a rate of 2 μ l/minute. The dose of adrenergic agonist was contained in 5 μ l artificial CSF and also injected at 2 μ l/minute. At -5 minutes the cannula with attached tubing was removed from the animal, flushed with distilled water and loaded with the appropriate solution of adrenergic agonist before being relocated in the ventricle.

The following β -blockers were used: l-, dl- and d-propranolol, atenolol and ICI 118551. Adrenergic agonists used were adrenaline, noradrenaline and phenylephrine.

2.3.3 Effect of icv β -blocker pretreatment on the response to icv adrenergic agonist - consequence of prior icv injection of phentolamine

For this series of experiments the α -blocker, phentolamine, was injected icv before repeating the injection schedule described in Section 2.3.2:

phentolamine icv =====	β -blocker icv =====	adrenergic agonist icv =====	
↑ ↑	↑ ↑	↑ ↑	time (mins)
-25 -22.5	-15 -10	0 2.5	

The dose of phentolamine was contained in 5 μ l artificial CSF and was injected over a period of 2.5 minutes.

Leakage of phentolamine from ventricular CSF to the systemic circulation was investigated in a separate series of experiments by comparing the diastolic pressor responses to increasing doses of intravenously injected phenylephrine before and 25 minutes after the central injection of phentolamine.

2.4.1 Effect of icv β -blockers on the cardiovascular responses to monopolar electrical stimulation in various brain areas in thiobutobarbitone anaesthetised rats

Animals were prepared as described in Section 2.3.1. Electrodes

for electrical stimulation were made by Mr.P.W.Marshall of ICI plc. However, a description of their preparation is pertinent to this Section.

Precut lengths (about 7.5 cm) of stainless steel wire (cat.no. SS20-3, Clark Electromedical Instruments) were electrolytically sharpened in a mixture containing 34 ml H₂SO₄ and 42 ml phosphoric acid, made up to 100 ml with distilled water. A number of the wires were placed in a holder and attached to the slowly revolving drive shaft of a horizontally positioned kymograph. The wires were immersed in the electrolyte to a depth of 1-2 cm and electrolysis initiated by applying a dc potential of 6 Volts across the wires (anode) and a carbon rod dipped in the electrolyte (cathode).

When sharpened, the electrodes were immersed successively in 10% HCl, distilled water, absolute alcohol, acetone, and xylene, in which they were stored until insulated. To insulate, the electrodes were dipped in epoxy resin (EPR-4, Clark Electromedical Instruments) to a depth of about 3 cm and then slowly and evenly withdrawn by an electrically driven motor. They were then baked for 30 minutes in an oven at a temperature of about 150 °C.

To check the uninsulated tip length each electrode was placed in saline and viewed under a microscope with calibrated eyepiece. A 6 Volt dc potential applied across the electrode (cathode) and the saline (anode) caused bubbles to appear along the uninsulated surface of the electrode tip. Electrodes with tip lengths of 10-40 µm were used in subsequent experiments. Electrodes were bubble-tested before each experiment.

Electrodes were mounted in an electrode carrier on the

stereotaxic instrument. A typical set-up is shown in Figure 6, with an electrode and injection cannula in position in the rat's brain.

2.4.2 Electrical stimulation

Negative-going square wave pulses were delivered to the electrode from either a Grass S48 or Farnell stimulator. Constant current stimulation was ensured by the interposition of a constant current device between stimulator and electrode. One of 3 types of devices was used: a Grass Instruments CCU 1A, a unit made by ICI plc, or a unit made by the author (Sheridan, 1982). The indifferent anodal electrode was attached via an alligator clip to the subcutaneous tissue exposed by the scalp incision. Electrical stimulation was effected by positioning of the electrode tip in the desired brain region and stimulating at 20-100 Hz, 200-300 μ A, the final frequency range and current depending on the magnitude of the pressor responses obtained at each site. Pulse width was kept at 2 msec and train duration was 5 seconds.

The following brain regions were electrically stimulated (coordinates according to König & Klippel, 1963):

anterior hypothalamic nucleus	A +6.28	L 0.6	H -2.5	mm
posterior hypothalamus	A +3.50	L 1.0	H -2.5	mm
central amygdaloid nucleus	A +5.66	L 3.5	H -2.5	mm
median raphe nucleus	A +0.35	L 0	H -2.5	mm

2.4.3 Protocol for electrical stimulation experiments

The injection cannula was filled with the appropriate drug solution and located in the lateral cerebral ventricle as described in Section 2.2.2. The electrode was positioned in one of the 4 regions described above (Section 2.4.2). Test stimulations (60 Hz, 200 μ A, 2 msec pulse width, 5 second train duration) were made at various horizontal (H) coordinates near to those given in Section 2.4.2 until a position was found where the blood pressure response was maximal. A frequency-response analysis was then made using stimulation frequencies within the range 20-100 Hz. β -blocker (dissolved in 10 μ l artificial CSF) was then injected icv at a rate of 2 μ l/minute and the frequency-response curve repeated 10 minutes after the injection.

2.4.4 Verification of stimulation site

At the end of each experiment anodal dc current (0.5 mA, 20 seconds) was passed through the stimulating electrode to deposit iron ions in the brain tissue surrounding the electrode tip. Ten μ l of a 1% w/v aqueous solution of Evans Blue dye was injected through the icv injection cannula. Following cardiac perfusion with saline and formalin and fixation of the brain (see Section 2.1.3), the site of stimulation was visualised by immersion of a block of brain containing the stimulated area in a saturated solution of potassium ferrocyanide. Iron(III) ions in the tissue react with the ferrocyanide to yield a blue-coloured complex. Histological preparation of tissues was then as described previously (Section 2.1.3).

2.5.1 Preparation of anaesthetised cats for third ventricle infusion and electrical stimulation

Male cats (Alderley Park SPF), weighing 1.9-3.5 kg, were anaesthetised with α -chloralose (80 mg/kg i.p.). The trachea was cannulated and the animal artificially respired ('Ideal' respiration pump, C.F.Palmer - 12 ml air/kg/stroke, 20 strokes/minute). A femoral artery and vein were catheterised for the measurement of blood pressure and intravenous injection of drug, respectively. The animal was positioned in a stereotaxic instrument (DKI 1204, David Kopf Instruments). A 4-5 cm dorsal midline incision was made on the animals head and the underlying tissue cleared to reveal the skull bone. Electrocautery was used throughout to minimise bleeding.

Two burr holes, each about 5 mm diameter, were drilled into the skull at positions vertically above the ansa lenticularis and the third ventricle. The tough dura mater was scraped away to facilitate unrestricted entry of the cannula and electrode into the brain substance. The bone of the skull is highly vascularised and bleeding was a continual problem. However, this was effectively controlled by the application of a haemostatic gauze ('Surgicel', Ethicon) to the area of bleeding.

The stereotaxic instrument bore two carriers - one held a 23 gauge stainless steel cannula for the infusion of drug while the other held a stainless steel electrode of the type described in Section 2.4.1. The following coordinates from the stereotaxic atlas of Snider & Niemer (1961) were used:

ansa lenticularis	A +10	L -6.5	H -2.5	mm
third ventricle	A +10	L +1.0	H +6.5	mm

A coronal section of the cat brain at the A +10 mm coordinate is shown in Figure 42.

End expiratory $p\text{CO}_2$ was monitored throughout the experiment by means of a Beckman LB-2 Medical Gas Analyser. The stroke of the respiration pump was adjusted to maintain the $p\text{CO}_2$ within the range 26-31 mmHg. Blood gas analysis was performed every 60 minutes on a 1 ml sample of femoral artery blood (Corning 175 automatic pH/blood gas system). Acidosis was corrected by intravenous injection of the appropriate volume of an 8.4% w/v solution of sodium bicarbonate. Body temperature was maintained at 37 °C by means of radiant heat.

2.5.2 Monopolar electrical stimulation in the ansa lenticularis

The electrode was lowered to instrument zero (Section 2.1.2) and test stimulations (60 Hz, 200 μA , 2 msec pulse width, 5 second train duration) were made at successively more ventral positions of the electrode tip, the electrode being moved downwards in steps of 0.3 mm. Ansa lenticularis stimulation yielded characteristic cardiovascular and somatic responses including an increase in blood pressure and tachycardia, pupillary dilatation and retraction of the nictitating membranes.

Negative-going square wave pulses were delivered to the stimulating electrode via a constant current device, the indifferent (anodal) electrode being attached to the subcutaneous tissue exposed by the scalp incision.

2.5.3 Third ventricle infusion of drugs

A syringe was filled with the appropriate drug solution, placed in the holder of an infusion pump (Harvard Apparatus), and attached to the injection cannula via a length of polyethylene tubing. The pump delivered drug solution at a rate of 0.08 ml/minute. The tubing and cannula were allowed to fill with drug solution and the pump switched off. The infusion cannula was lowered into the third ventricle (2.5.1).

dl-Propranolol hydrochloride and procaine hydrochloride were dissolved in artificial CSF (2.3.1) to give final concentrations of 0.5 and 2.4 mg/ml, respectively.

2.5.4 The effect of drugs on the cardiovascular responses to ansa lenticularis stimulation

Control blood pressure and heart rate responses to stimulation in the ansa lenticularis were obtained (60 Hz, 200 μ A, 2 msec pulse width, 5 second train duration). Drug was then either injected intravenously or infused into the third ventricle. Propranolol was administered to give final total doses of 30, 100, 300 and 500 μ g/kg. The cardiovascular response to ansa lenticularis stimulation was recorded 5 minutes after the administration of each dose.

In one animal procaine hydrochloride (400 μ g) was infused into the third ventricle and its effect on the response to ansa lenticularis stimulation recorded.

Verification of the location of the cannula in the third ventricle was performed by infusing 500 μ l of a 1% w/v aqueous

solution of Evans Blue dye, followed by post mortem gross dissection of the brain (see Section 2.1.3). Verification of electrode placement in the ansa lenticularis was as described in Section 2.1.3.

2.6.1 Drugs and general chemicals

† phentolamine mesylate	CIBA
† 1-noradrenaline bitartrate	Sigma
† adrenaline hydrogen tartrate	BDH
† phenylephrine hydrochloride	Sigma
† isoprenaline sulphate	BDH
† procaine hydrochloride	Sigma
1-,dl-,d-propranolol hydrochloride	ICI
atenolol	ICI
†† ICI 118551 hydrochloride	ICI
timolol maleate	Merck Sharp & Dohme
hexamethonium bromide	Koch-Light
halothane ('Fluothane')	ICI
thiobutobarbitone Na ('Inactin')	BYK
††† arginine vasopressin antagonist	
†††† α-chloralose	Aldrich
heparin ('Pularin' 25000 U/ml)	Duncan Flockhart
formalin	BDH
polyethylene glycol 400	BDH
Evans Blue	Sigma
potassium ferrocyanide	May & Baker

† Prepared immediately before use.

†† ICI 118551 = erythro-DL-(7-methylindan-4-yloxy)-3-isopropyl-

aminobutan-2-ol. ICI 118551 is a highly β_2 -selective blocking agent (Bilski et al, 1980; O'Donnell & Wanstall, 1980). At the concentrations used in the present study the ICI 118551 was not readily soluble in artificial CSF. Consequently, the compound was dissolved in 1/5th the final volume of warmed polyethylene glycol 400. The solution was then made up to final volume with artificial CSF. The solvent had no effect on the control cardiovascular response to icv adrenaline.

††† arginine vasopressin antagonist = $d(CH_2)_5Tyr(Me)arginine$ vasopressin. The compound is an inhibitor of the pressor actions of arginine vasopressin (Kruszynski et al, 1980) and was a gift from Professor M.Manning, Department of Biochemistry, Medical College of Ohio, Toledo, Ohio 43699.

†††† α -chloralose was made up to give a 5% w/v solution -
1 g α -chloralose was dissolved in 10 ml warmed polyethylene glycol 400. The solution was made up to a final volume of 20 ml with saline. The anaesthetic was used while still warm.

2.6.2 Doses of drugs

Doses of drugs given in the text (with the exception of bases) are expressed in terms of the salt.

2.7.1 Data analysis

The blood pressure pulse does not take the form of a sine

wave and, consequently, mean arterial pressure cannot be derived by arithmetic averaging of the systolic and diastolic blood pressure values. A routinely used approximation of the mean arterial pressure (MAP) was therefore used in the present study:

$$\text{MAP} = \frac{\text{systolic blood pressure} - \text{diastolic blood pressure}}{3} + \text{diastolic BP}$$

Data were analysed for statistical significance with Student's t test for paired or unpaired comparisons, depending on the experimental design.

RESULTS

Chapter 3

3.1 General considerations

Throughout this Chapter doses of drugs (except bases) are expressed in terms of the salt. Group data are expressed as means \pm standard errors of the means. The following abbreviations are used: MAP - mean arterial pressure, SBP - systolic blood pressure, bpm - beats per minute. For ease of cross-reference, the appropriate Section in the Materials and Methods Chapter has been indicated in parenthesis at the end of most of the headings in this Chapter.

3.2 Resting blood pressure and heart rates of anaesthetised rats (2.2.1 and 2.3.1)

The resting blood pressures of the halothane anaesthetised rats (81 ± 1 mmHg; $n = 113$) were lower than those of the thiobutobarbitone anaesthetised rats (117 ± 1.5 mmHg; $n = 200$). Similarly, heart rates of the former group (370 ± 4 bpm; $n = 91$) were lower than those of the latter group (421 ± 4 bpm; $n = 154$).

3.3 Intracerebroventricular (icv) injection of β -blockers (2.2.2)

In halothane anaesthetised animals icv dl-propranolol (100 μ g) produced a significant ($P < 0.01$) decrease in MAP, the response being fully developed 5 minutes after completion of the injection, by which time MAP had fallen by 12 ± 2.9 mmHg (Figures 7 and 8).

In thiobutobarbitone anaesthetised rats icv injection of dl-propranolol, atenolol and ICI 118551 (100 μ g) failed to lower blood pressure (Figure 9). In fact, the two lower doses of

dl-propranolol (10 and 30 μg) produced small but significant ($P < 0.05$) elevations in MAP which lasted for at least 10 minutes after completion of the injection (Figure 9). Icv injections of vehicle (artificial CSF), dl-propranolol (100 μg), d-propranolol (30 μg), atenolol (100 μg) and the β_2 -selective blocker, ICI 118551 (100 μg), did not significantly alter blood pressure (Figure 9).

dl-Propranolol (100 μg) significantly ($P < 0.05$) lowered heart rate by 59 ± 21 bpm following icv injection in halothane anaesthetised rats (Figures 7 and 8). The time course of the fall in blood pressure paralleled that of the fall in heart rate in these animals.

In thiobutobarbitone anaesthetised rats icv dl-propranolol (10, 30 and 100 μg) produced significant ($P < 0.01$) dose-related reductions in heart rate (22 ± 5 , 53 ± 6 , 57 ± 9 bpm, respectively; Figure 10). Significant ($P < 0.01$) reductions in heart rate (66 ± 10 bpm) were also seen after icv injection of 100 μg atenolol (Figure 10). Vehicle, d-propranolol (30 μg) and ICI 118551 (100 μg) failed to affect heart rate significantly (Figure 10).

3.4 Leakage of dl-propranolol from CSF (2.2.2)

In halothane anaesthetised animals the possible leakage of icv injected dl-propranolol from the CSF to the systemic circulation was investigated by comparing the tachycardic responses to intravenous isoprenaline (0.1 μg) before and after icv injection of 100 μg dl-propranolol (Figure 11B). Five minutes after the icv injection the tachycardia was reduced to 15.3 ± 5 % of its control level.

In a separate series of experiments the inhibition of isoprenaline-induced tachycardia by intravenous injections of dl-propranolol (5, 10, 20 and 40 μg) was studied (Figure 11A). Comparison of Figures 11A and 11B indicated that nearly 40% of the centrally injected dose of dl-propranolol had leaked into the circulation 5 minutes after the icv injection.

3.5 Intravenous injection of dl-propranolol

Intravenous injection of dl-propranolol (50 μg) produced significant ($P < 0.05$) falls in blood pressure (10 ± 3.2 mmHg) and heart rate (47 ± 5 bpm) in halothane anaesthetised rats. These responses occurred immediately following the injection and both parameters decreased with a similar time course.

The falls in blood pressure and heart rate produced by intravenous propranolol (50 μg) were not statistically different from those produced by icv propranolol (100 μg).

3.6 Intrahippocampal injection of propranolol (2.2.3)

Unilateral intrahippocampal injection of l-propranolol (1 and 2 μg) produced significant dose-dependent reductions in MAP in halothane anaesthetised rats (Figure 12). At 15 minutes after the start of the injection l-propranolol (1 and 2 μg) produced falls in MAP of 4.2 ± 2.9 and 6.8 ± 1.6 mmHg, respectively. Intrahippocampal injections of either saline vehicle (0.4 μl) or d-propranolol (2 μg) did not significantly affect MAP at this time (Figure 12).

Heart rate was significantly lowered by intrahippocampal injections of 1 and 2 μg l-propranolol (18 ± 5 and 31 ± 8 bpm, respectively; Figure 13). Saline vehicle (0.4 μl) or d-propranolol (2 μg) failed to affect heart rate significantly except at 15 minutes after the start of the injection, where saline produced a small, but significant ($P < 0.05$) reduction in heart rate (Figure 13).

3.7 Anatomical localisation of the hippocampal response (2.2.4)

Injections of l-propranolol (2 μg) were made in 5 brain regions at small distances away from the original injection site. The coordinates of these areas relative to the dorsal hippocampal injection site are given in Figure 4. For these experiments only the changes in MAP and heart rate at 15 minutes after the start of the icv injections were compared with pretreatment controls (that is, ΔMAP_{15} and ΔHR_{15} , respectively). Results are tabulated in Table 1 (overpage).

3.8 Intravenous v. intrahippocampal l-propranolol

The cardiovascular effects of intrahippocampal and intravenously injected l-propranolol (2 μg) are shown in Figure 14. Intrahippocampal injections produced a significant lowering of MAP at 5 (5.6 ± 1.2 mmHg), 10 (7.4 ± 0.5 mmHg) and 15 (6.8 ± 1.2 mmHg) minutes after the injection. Intravenous injection of l-propranolol (2 μg), however, produced a significant lowering of MAP only at 5 minutes after the injection (5.8 ± 1.5 mmHg).

<u>Approximate anatomical location</u>	<u>Coordinates (mm)</u>		<u>ΔMAP₁₅ (mmHg)</u>	<u>ΔHR₁₅ (bpm)</u>
DORSAL HIPPOCAMPUS	AP +1.27	L +3.1 H +1.4	-6.8 ± 1.2 ***	-31 ± 8 *
DENTATE GYRUS OF HIPPOCAMPUS	AP +1.27	L +3.1 H -0.6	-7.1 ± 2.3 *	-32 ± 12
CORTEX	AP +1.27	L +5.1 H +1.4	+0.5 ± 2.1	-14 ± 5
SUPERIOR COLLICULUS	AP +1.27	L +1.1 H +1.4	-6.6 ± 2.8	-22 ± 8
HIPPOCAMPUS	AP +2.27	L +3.1 H +1.4	-8.4 ± 2.6 **	-43 ± 9 ***
COMMISSURE OF THE DORSAL FORNIX	AP -0.10	L +3.1 H +1.4	-4.9 ± 1.1	-31 ± 8 ***

(Coordinates according to König & Klippel, 1963)

Significant differences from pretreatment control values are denoted: * P < 0.05 ** P < 0.02 *** P < 0.01

TABLE 1 Anatomical localisation of the intrahippocampal response (see Section 3.7)

Intrahippocampal 1-propranolol (2 μg) produced a significant lowering of heart rate at all 3 time points (16 ± 5 , 25 ± 7 and 31 ± 8 bpm at 5, 10 and 15 minutes, respectively). Intravenous injection of the same dose did not significantly affect heart rate (Figure 14).

3.9 Intrahippocampal injection of timolol, atenolol and isoprenaline

(2.2.3)

Intrahippocampal injection of timolol (2 μg), atenolol (2 μg) and isoprenaline (1 and 2 μg) failed to affect MAP significantly, although isoprenaline appeared to raise MAP in a dose-related fashion (Figure 15).

Heart rates were not significantly altered by any of the above injections except isoprenaline (2 μg), which significantly ($P < 0.05$) increased heart rate at 5 minutes after the start of the injection (Figure 16).

3.10 Icv injection of β -blockers and adrenaline (2.3.2)

In thiobutobarbitone anaesthetised rats icv injection of adrenaline (20 μg) had no significant effect on MAP (Figures 17 and 19). However, heart rate was significantly ($P < 0.05$) lowered by 24 ± 9 bpm ($n = 12$). The fall in heart rate either began during the course of or within 1 minute after the adrenaline injection (for example, see Figure 17). The magnitude of the bradycardia was unaffected by any of the icv pretreatments described below and no further reference to it will be made in this Chapter.

Following icv pretreatment with dl-propranolol (30 μg), icv adrenaline produced a marked pressor response (Figure 18). The response was dependent on the dose of dl-propranolol within the range 10-100 μg (Figure 19). (Pressor responses: 10 μg - 21 ± 2.8 mmHg, 30 μg - 32.1 ± 2.6 mmHg, 100 μg - 41.6 ± 3.4 mmHg).

Figure 20 shows the effect of icv pretreatment with dl-propranolol (100 μg), atenolol (100 μg) and ICI 118551 (100 μg) on the subsequent pressor response produced by icv adrenaline (20 μg). Adrenaline produced significant increases in MAP following icv pretreatment with all 3 β -blockers (Figure 20). No significant change in MAP was observed after icv pretreatment with vehicle (10 μl artificial CSF).

3.11 Icv v. intravenous atenolol on the response to icv adrenaline

The MAP changes produced by icv adrenaline (20 μg) following either icv or intravenous pretreatment with atenolol (100 μg) are shown in Figure 21, in which the injection schedules are also indicated. After intravenous injection of atenolol, icv adrenaline did not produce any change in MAP.

3.12 Further analysis of the responses to icv β -blockers and adrenaline (2.3.2)

The pressor responses to icv adrenaline (20 μg) following icv pretreatment with 30 μg of β -blocker are shown in Figure 22. At 4 minutes from the start of the adrenaline injection the following MAP changes were recorded (see also Figure 22):

ICI 118551 - 47.3 ± 3.6 mmHg, dl-propranolol - 32.1 ± 2.6 mmHg,
atenolol - 11.1 ± 4.5 mmHg, d-propranolol - 3.9 ± 1.8 mmHg.

Only the pressor responses to ICI 118551 and dl-propranolol were statistically significant at the 3 blood pressure sampling times of the experiment.

The pressor response to ICI 118551 was significantly ($P < 0.01$) greater than that to dl-propranolol at the 4 minute MAP sampling point (Figure 22).

The interrelationship between the dose of ICI 118551 (3, 10 and 30 μ g) pretreatment and the pressor response to icv adrenaline (1.8, 6 and 20 μ g) was explored, and the results are shown in Figure 23.

3.13 Intravenous injections of ICI 118551 and adrenaline

Intravenous adrenaline (0.3 and 1 μ g) produced dose-dependent increases in MAP which were significantly ($P < 0.001$) enhanced by the prior intravenous injection of 30 μ g ICI 118551 (Figure 24). For comparison, the pressor response to icv adrenaline (20 μ g) after pretreatment with icv ICI 118551 (30 μ g) has been included in Figure 24.

These doses of intravenous adrenaline only produced tachycardia (Cf. Section 3.10).

3.14 Icv injections of phentolamine, ICI 118551 and adrenaline (2.3.3)

The pressor response to icv adrenaline (20 μ g) following pretreatment with icv ICI 118551 (6 μ g) was inhibited in a dose-dependent manner by the prior icv injection of phentolamine

(15 and 50 μg) (Figure 25). The injection schedule is also shown in the Figure.

3.15 Intravenous phenylephrine and icv phentolamine

Intravenous phenylephrine (1, 3 and 10 μg) produced dose-dependent increases in diastolic blood pressure. Following pretreatment with icv phentolamine (50 μg) 25 minutes earlier, the pressor responses to intravenous phenylephrine were unaffected (Figure 26).

3.16 Intravenous hexamethonium and vasopressin antagonist on the response to icv adrenaline

The pressor response to icv adrenaline (20 μg) following pretreatment with icv ICI 118551 (30 μg) was significantly ($P < 0.001$) enhanced by the intravenous injection of 3 mg hexamethonium.

Intravenous vasopressin antagonist (20 μg) failed to modify the adrenaline pressor response (Figure 27).

Resting MAP was considerably lower in the hexamethonium treated animals (74 ± 4.7 mmHg compared to 119 ± 3.3 mmHg in the control group).

3.17 Icv ICI 118551 on the response to icv noradrenaline and phenylephrine

Icv injections of noradrenaline (20 μg) and phenylephrine (20 and 60 μg) produced significant elevations of MAP (34.5 ± 5.6 mmHg, 8.8 ± 2.3 mmHg and 14.2 ± 2.7 mmHg, respectively). However, these

responses were not significantly altered by icv pretreatment with 30 µg ICI 118551 (Figure 28).

3.18 Electrical stimulation in the rat CNS (2.4.2)

Electrical stimulation in the anterior hypothalamus, posterior hypothalamus, amygdala and median raphe nucleus produced frequency-dependent increases in systolic blood pressure (Figures 29A, 30A, 31A and 32, respectively, and Table 2 (overpage)). Stimulation in the posterior hypothalamic site evoked the greatest changes in systolic blood pressure (Figure 30A and Table 2). Rats were anaesthetised with thiobutobarbitone. Heart rate changes during all these stimulations were small and variable.

3.19 Icv β-blockers on the pressor responses to central stimulation (2.4.3)

Icv dl-propranolol (50 µg) appeared to enhance the pressor responses produced by stimulation in the anterior hypothalamus. However, statistical significance ($P < 0.01$) was achieved only at the lowest frequency of stimulation (Figure 29B).

Pressor responses to electrical stimulation in the posterior hypothalamus were unaffected by the icv injection of 100 µg dl-propranolol (Figure 30B).

Similarly, icv dl-propranolol (50 µg) failed to modify the pressor responses produced by stimulation in the amygdala (Figure 31B) or median raphe nucleus (Figure 33).

Frequency † ‡Location	Increase in systolic blood pressure (mmHg)				
	20	40	60	80	100
ANTERIOR HYPOTHALAMUS	-	12 ± 3	25 ± 3	30 ± 3	36 ± 2
POSTERIOR HYPOTHALAMUS	3 ± 1	34 ± 4	66 ± 5	-	-
AMYGDALA	-	12 ± 3	24 ± 3	37 ± 5	-
MEDIAN RAPHE NUCLEUS	-	16 ± 2	42 ± 2	57 ± 4	-

TABLE 2 Pressor responses to electrical stimulation in the rat CNS. See Section 3.18.

Icv atenolol (50 μ g) did not affect the pressor responses to stimulation in the median raphe nucleus except at the highest frequency of stimulation, where the response was significantly ($P < 0.05$) potentiated (Figure 33).

3.20 Electrical stimulation in the cat CNS (2.5.2)

Electrical stimulation in the ansa lenticularis of the chloralose anaesthetised cat evoked an increase in blood pressure (Figures 34 - top trace and 41A). On cessation of stimulation there was an immediate bradycardia of 52 ± 11 bpm ($n = 6$); see Figures 35 - top trace, 38B and 39B. During this time blood pressure returned to pre-stimulation levels (Figures 34 - top trace and 41A). Accompanying these cardiovascular alterations were a number of other autonomic changes including bilateral pupillary dilatation and retraction of the nictitating membranes during the period of stimulation.

3.21 Third ventricle (VIII) infusion of dl-propranolol on the cardiovascular response to ansa lenticularis stimulation (2.5.4)

The effects of VIII infusion of dl-propranolol (30, 100, 300 and 500 μ g/kg) on the blood pressure changes associated with ansa lenticularis stimulation are shown in Figures 34 and 36B. The increases in systolic blood pressure appeared to be diminished by the dl-propranolol infusions but these did not achieve significance.

The bradycardia accompanying cessation of stimulation was also reduced by VIII infusion of dl-propranolol and this was significant

($P < 0.05$) at the 300 $\mu\text{g}/\text{kg}$ dose (Figure 38B).

Increasing doses of VIII dl-propranolol appeared to impede the return of blood pressure to pre-stimulation levels following cessation of stimulation (Figure 34). This was particularly noticeable at doses of 300 $\mu\text{g}/\text{kg}$ and higher. To quantify this effect it was decided to compare the systolic blood pressure at 60 seconds after stimulation with the pre-stimulation systolic blood pressure. The resulting value was termed ΔSBP_{60} . Thus, a ΔSBP_{60} of zero implied that systolic blood pressure had returned to pre-stimulation levels by 60 seconds post-stimulation. Positive values of ΔSBP_{60} implied a delay in the return of the raised systolic blood pressure to pre-stimulation levels.

Figure 40A shows the effect of VIII infusions of dl-propranolol (30-500 $\mu\text{g}/\text{kg}$) on the ΔSBP_{60} . Although none of the values was significantly different from control, there appeared to be a steady increase in the ΔSBP_{60} with increasing doses of dl-propranolol.

In one animal procaine (375 μg) was infused into the third ventricle and the responses to ansa lenticularis stimulation recorded (Figure 41B). This treatment abolished the bradycardia normally associated with cessation of stimulation and blood pressure remained elevated for at least 40 seconds following stimulation.

3.22 Intravenous dl-propranolol on the responses to ansa lenticularis stimulation

Intravenous injections of dl-propranolol (30, 100, 300 and 500 $\mu\text{g}/\text{kg}$) produced significant ($P < 0.05$) inhibition of the systolic pressor response to ansa lenticularis stimulation except at the 300 $\mu\text{g}/\text{kg}$ dose (Figure 37B).

These doses did not significantly affect the bradycardia associated with cessation of stimulation, although there was a trend towards a reduction in the magnitude of the bradycardia (Figure 39B).

ΔSBP_{60} was not significantly changed from pretreatment control (Figure 40B).

3.23 Intravenous and VIII dl-propranolol on resting blood pressure and heart rate

Intravenous injection and VIII infusion of dl-propranolol (30, 100, 300 and 500 $\mu\text{g}/\text{kg}$) did not significantly alter resting systolic blood pressure although there was a trend towards a hypotension in both cases (Figures 36A and 37A).

All doses of intravenous dl-propranolol significantly ($P < 0.02$) lowered heart rate (Figure 39A). Although VIII infusion of dl-propranolol appeared to lower resting heart rate, none of the points was statistically different from pretreatment control (Figure 38A).

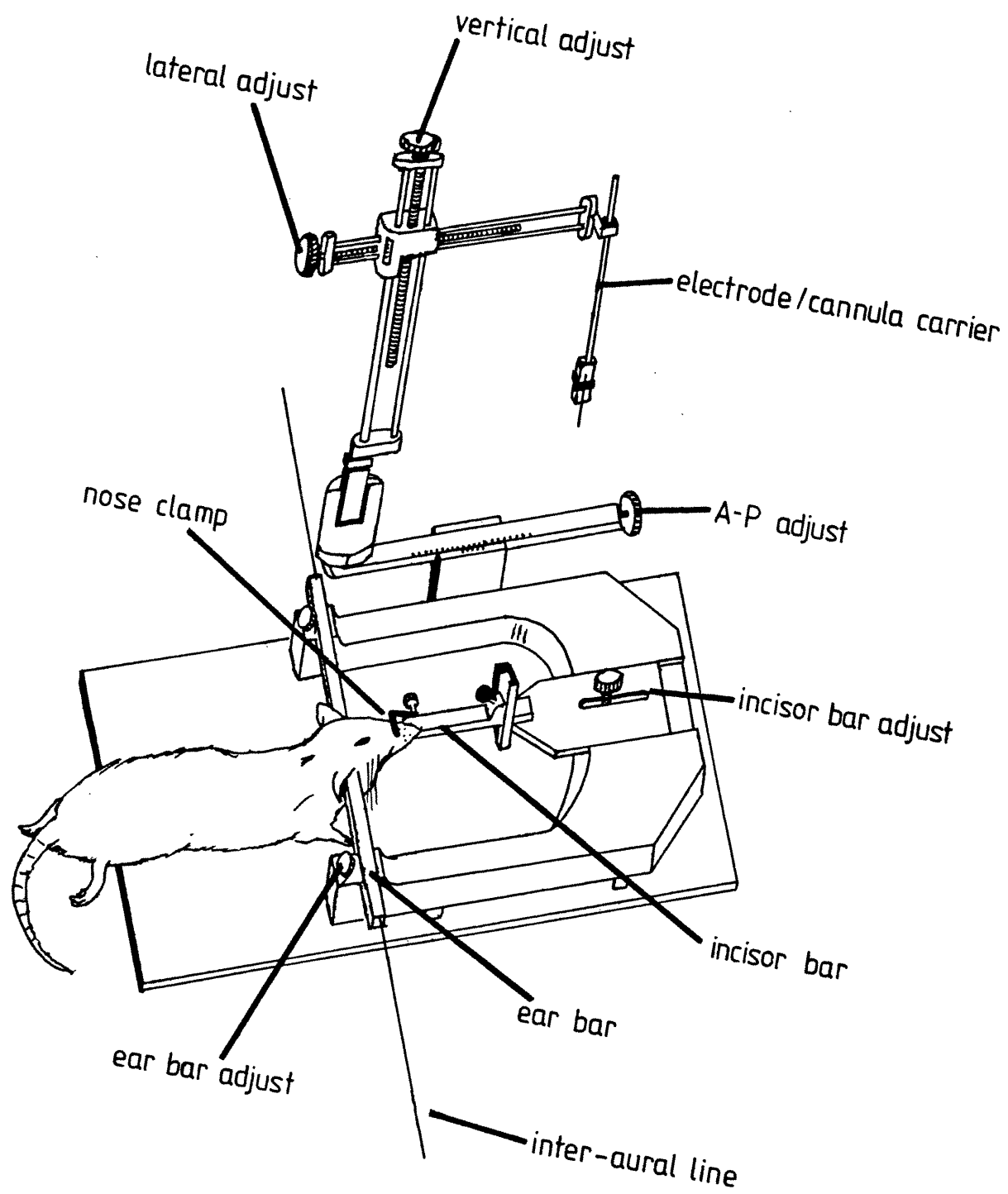

FIGURE 1

The David Kopf small animal stereotaxic instrument.
Explanation may be found in text (Section 2.1.2).

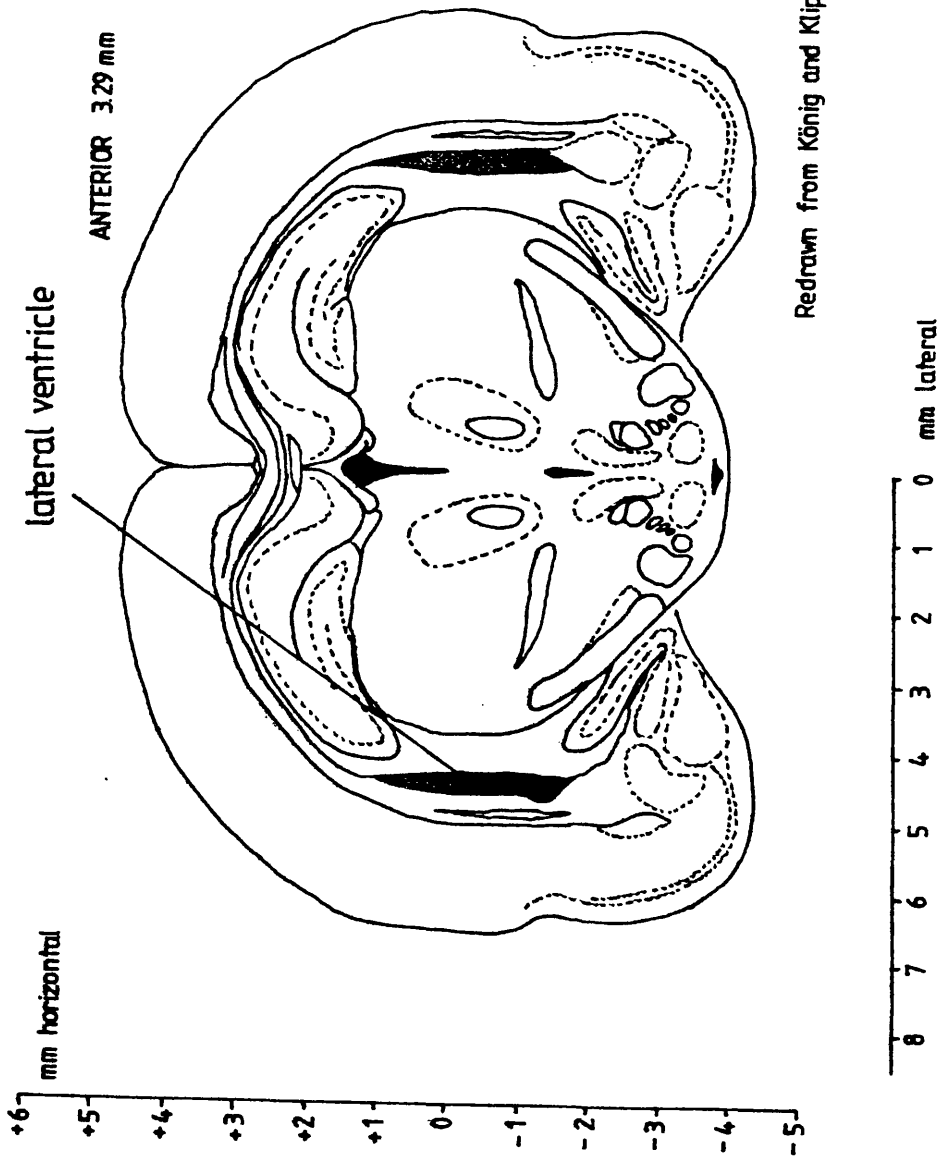
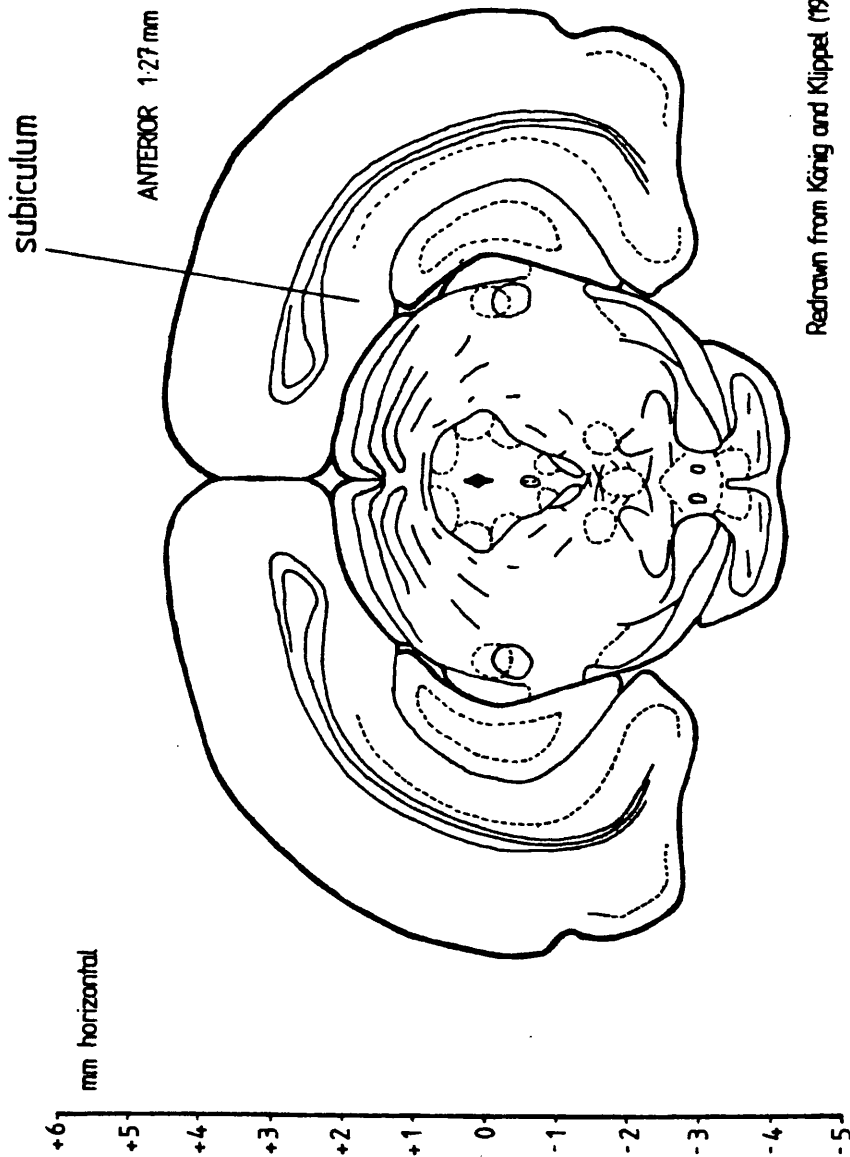

FIGURE 2

Coronal section of rat brain at the AP coordinate used to locate injections in the lateral cerebral ventricle. Redrawn from König & Klippel 1963.

Redrawn from König and Klippel (1963)



Redrawn from König and Klippel (1963)

FIGURE 3

Coronal section of rat brain at the AP coordinate used to locate injections in the subiculum of the dorsal hippocampus. Redrawn from König & Klippel, 1963.

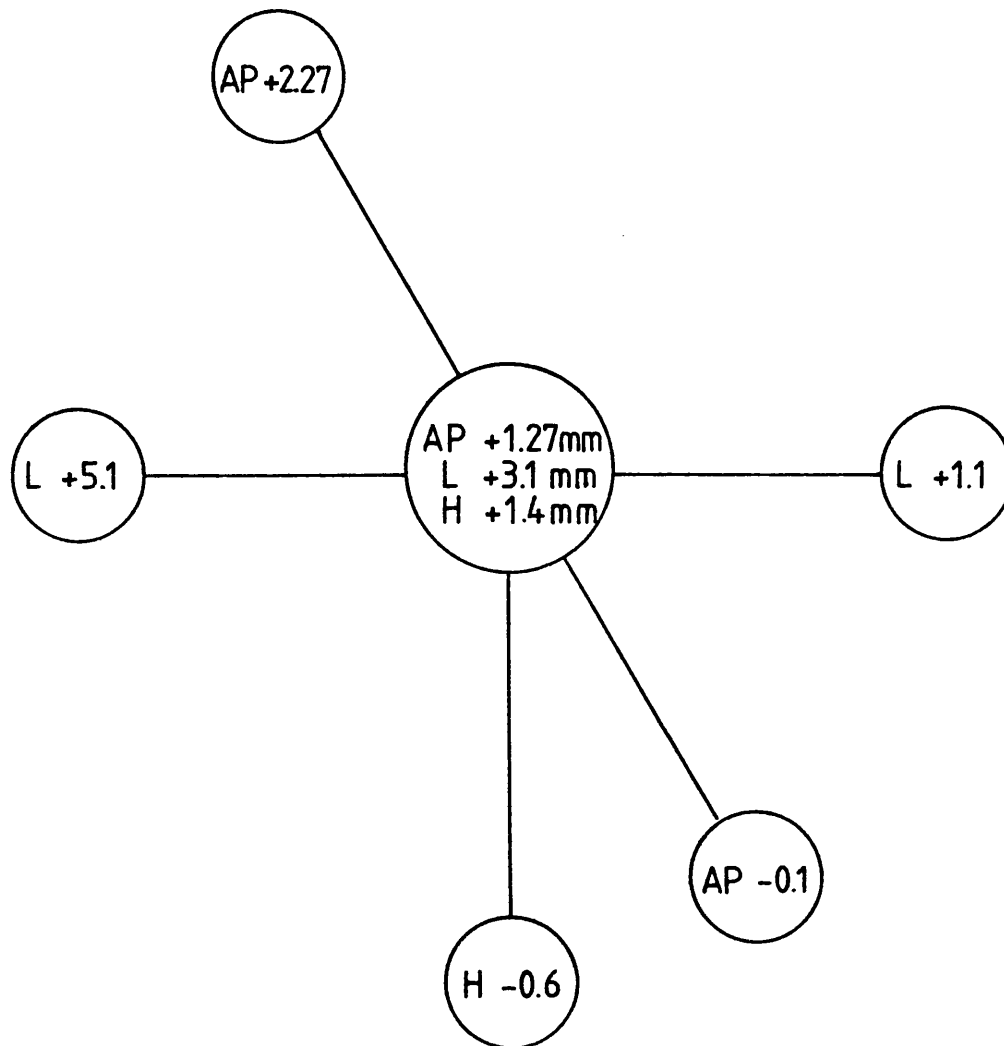
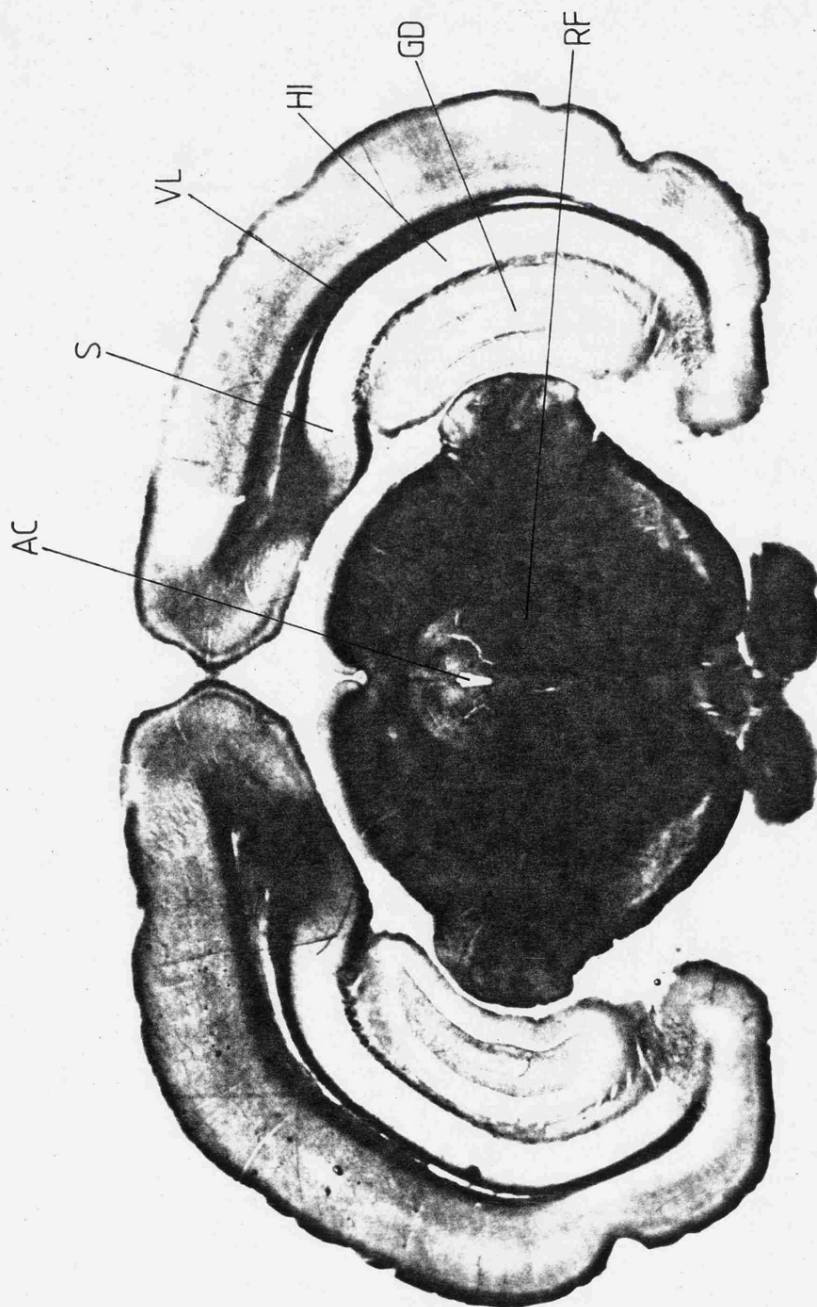

FIGURE 4

Anatomical localisation of the cardiovascular responses to dorsal hippocampal injections. Changes in blood pressure and heart rate are given in Table 1. The dorsal hippocampal injection site is represented by the coordinates in the larger central circle. Anterior-posterior, lateral and horizontal changes in the position of the injection site are indicated by the coordinates in the satellite circles. Coordinates according to König & Klippel, 1963. See text Sections 2.2.3 and 2.2.4.

FIGURE 5 70 μ m frozen section of rat brain at the AP coordinate shown diagrammatically in Figure 3. Major landmarks are indicated. The more intense shading in the left subiculum is the result of the injection of 0.4 μ l of a 1% solution of Evans Blue.



Key S - subiculum
 VL - lateral ventricle
 GD - dentate gyrus
 AC - cerebral aqueduct
 HI - hippocampus
 RF - reticular formation

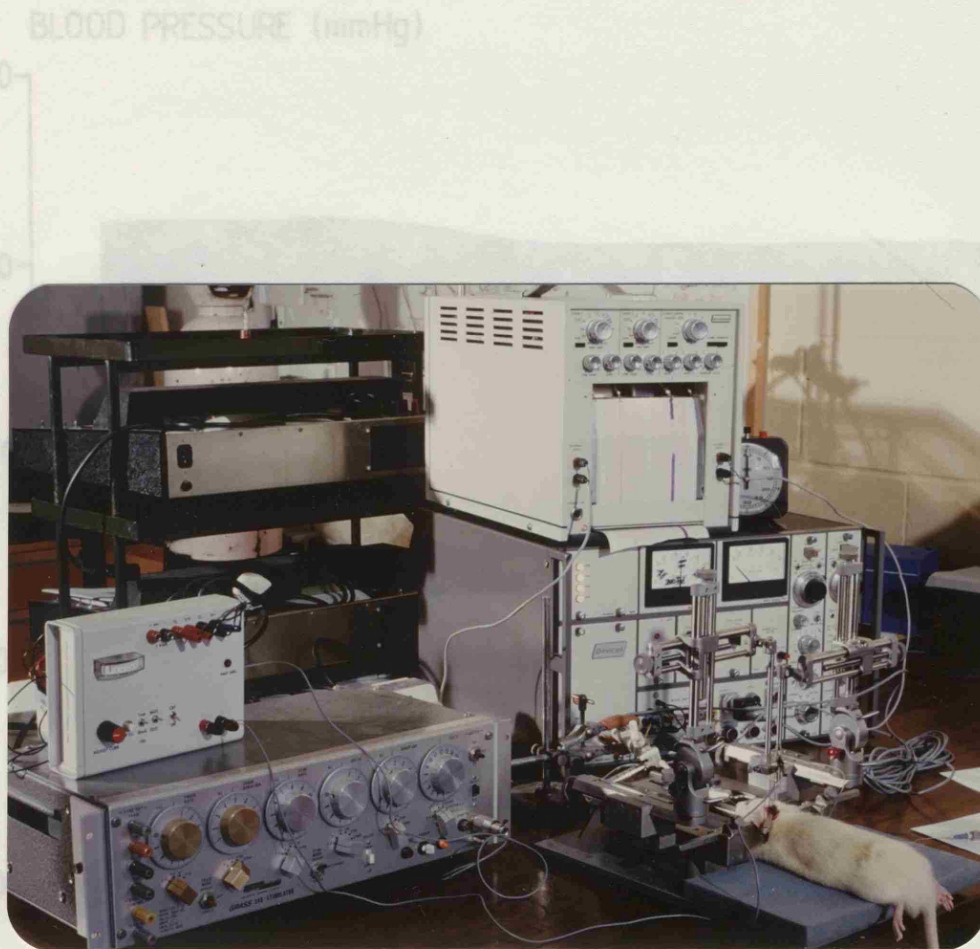

FIGURE 6

The experimental set-up used in the rat brain stimulation experiments. The lower left hand quadrant shows the constant current device resting on the stimulator. The left hand carrier on the stereotaxic instrument holds the electrode while the other holds the injection cannula (located in the lateral cerebral ventricle). The blood pressure and heart rate recording apparatus lies behind the stereotaxic instrument.

FIGURE 7

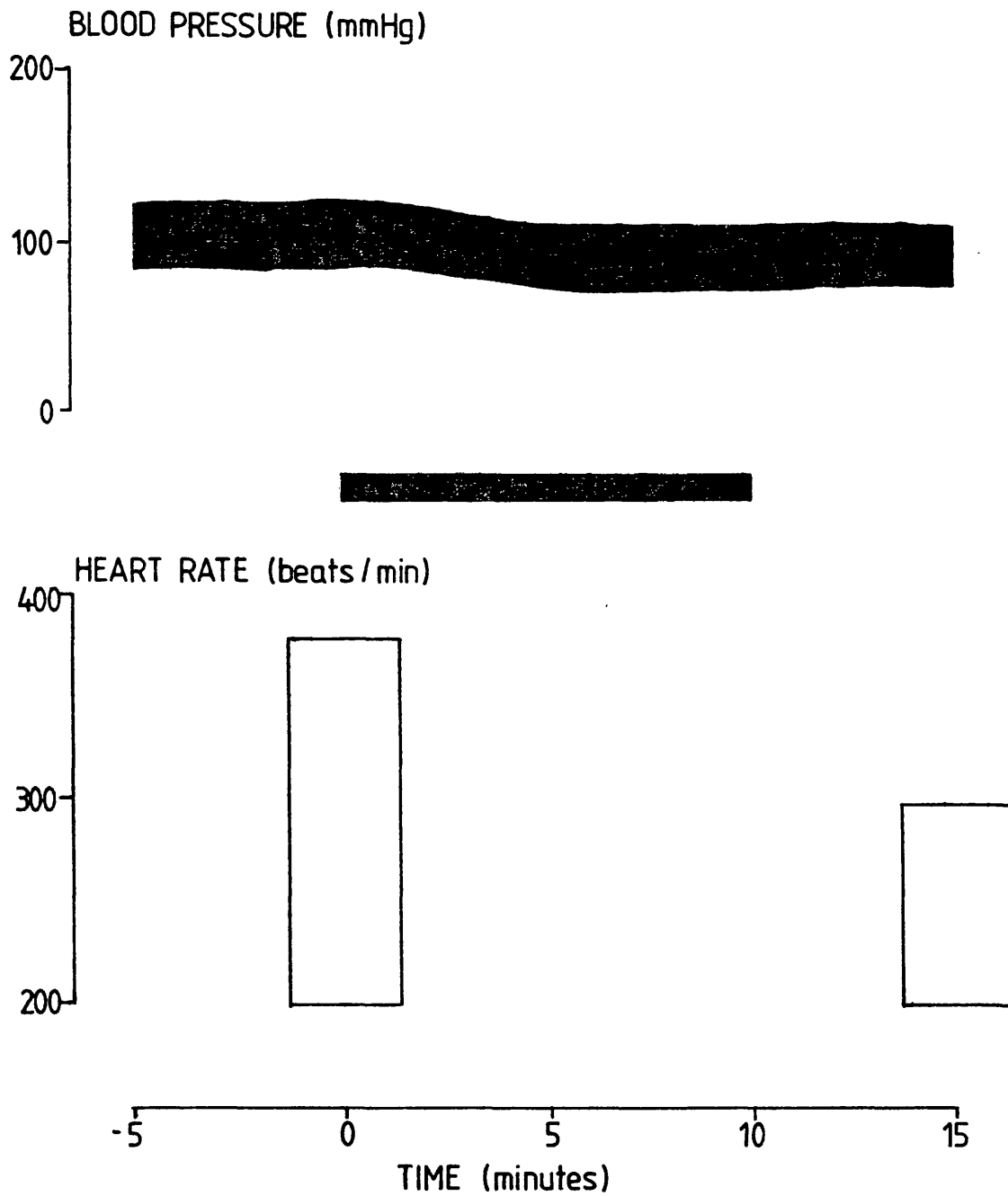

FIGURE 7

Effect on blood pressure (top) and heart rate of 100 μg dl-propranolol icv (injected in 10 μl saline during the period indicated by the horizontal bar) in a halothane anaesthetised rat. Heart rates were obtained by manual counting of the blood pressure pulses.

FIGURE 8

(Overpage) Effect on blood pressure and heart rate of icv vehicle (10 μ l saline) and 100 μ g dl-propranolol in the halothane anaesthetised rat (mean \pm sem). Saline (S) or propranolol (P) injection was started at 0 minutes and completed by 10 minutes. Figures in parentheses indicate the numbers of animals. Only values at 15 minutes were compared to pretreatment controls: * P < 0.05 ** P < 0.01

FIGURE 8

MEAN ARTERIAL PRESSURE (mmHg)

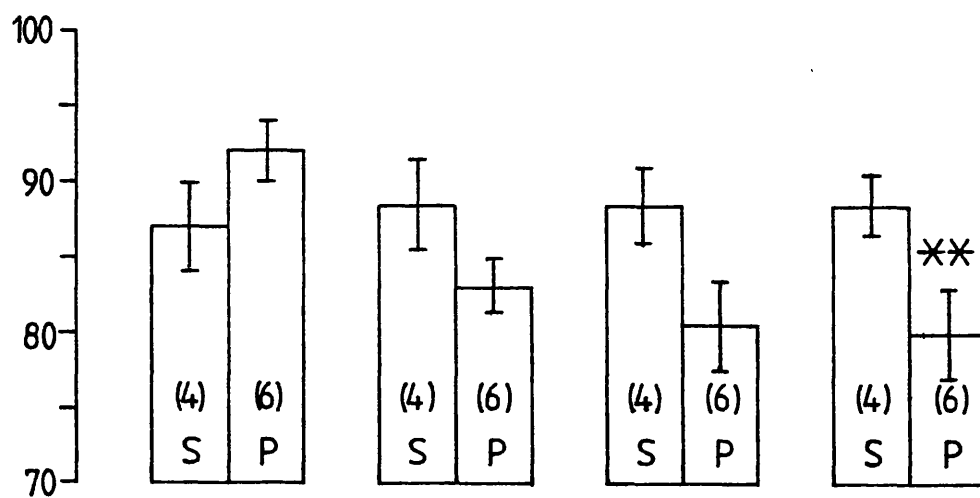

HEART RATE (beats/min)

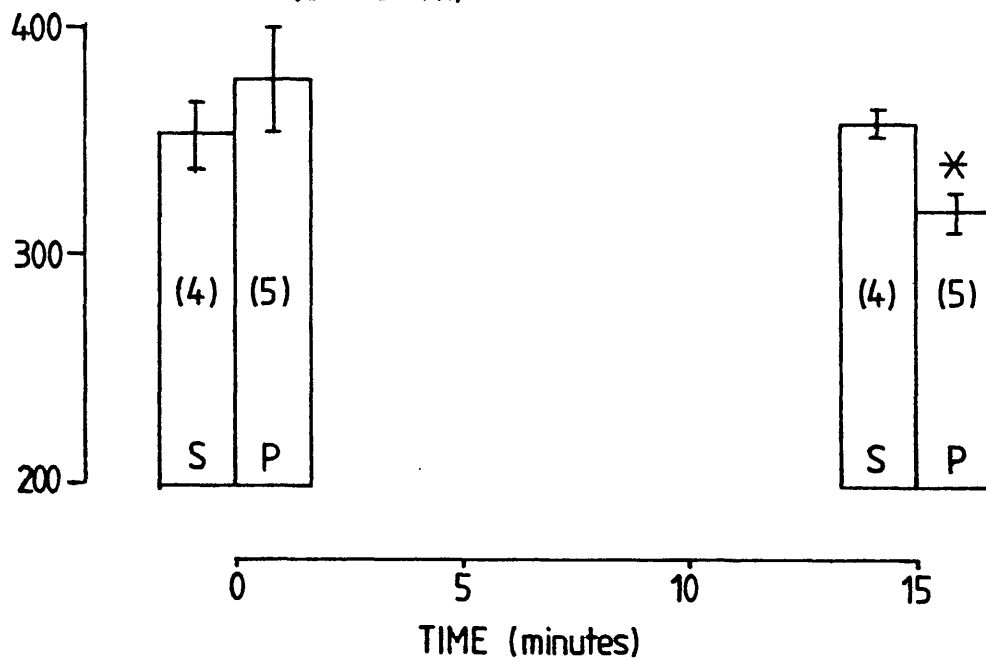

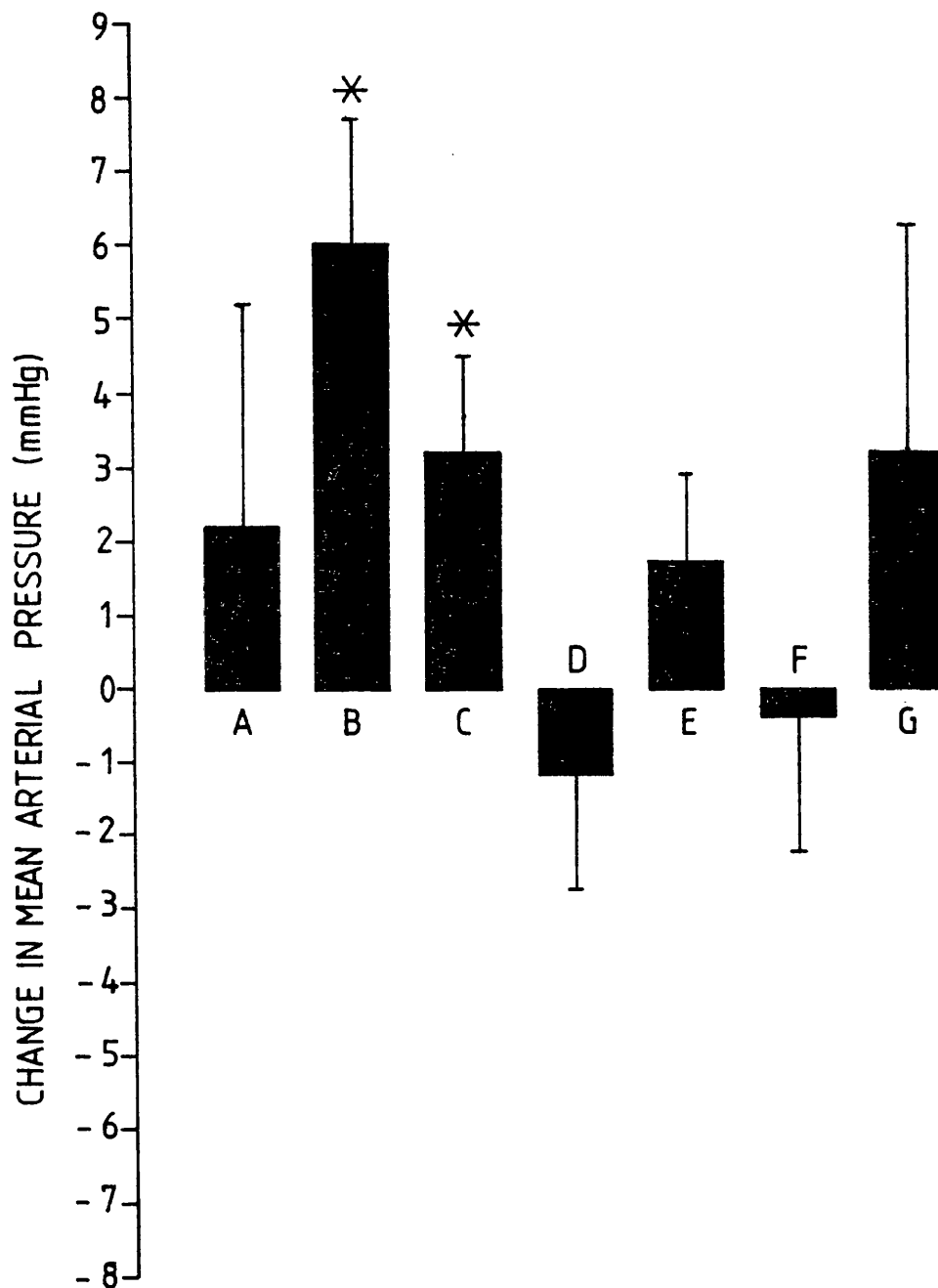

FIGURE 9 Effect on mean arterial pressure of thiobutobarbitone anaesthetised rats of icv injections of:

- A artificial CSF vehicle (10 μ l)
- B dl-propranolol (10 μ g)
- C dl-propranolol (30 μ g)
- D dl-propranolol (100 μ g)
- E d-propranolol (30 μ g)
- F atenolol (100 μ g)
- G ICI 118551 (100 μ g)

The change in mean arterial pressure (\pm sem) from pretreatment control value is shown at 15 minutes after the start of the injection. Injections lasted 5 minutes. Groups consisted of 7 animals except the atenolol (6) and d-propranolol (5) groups. Significant difference from pretreatment control denoted: * $P < 0.05$

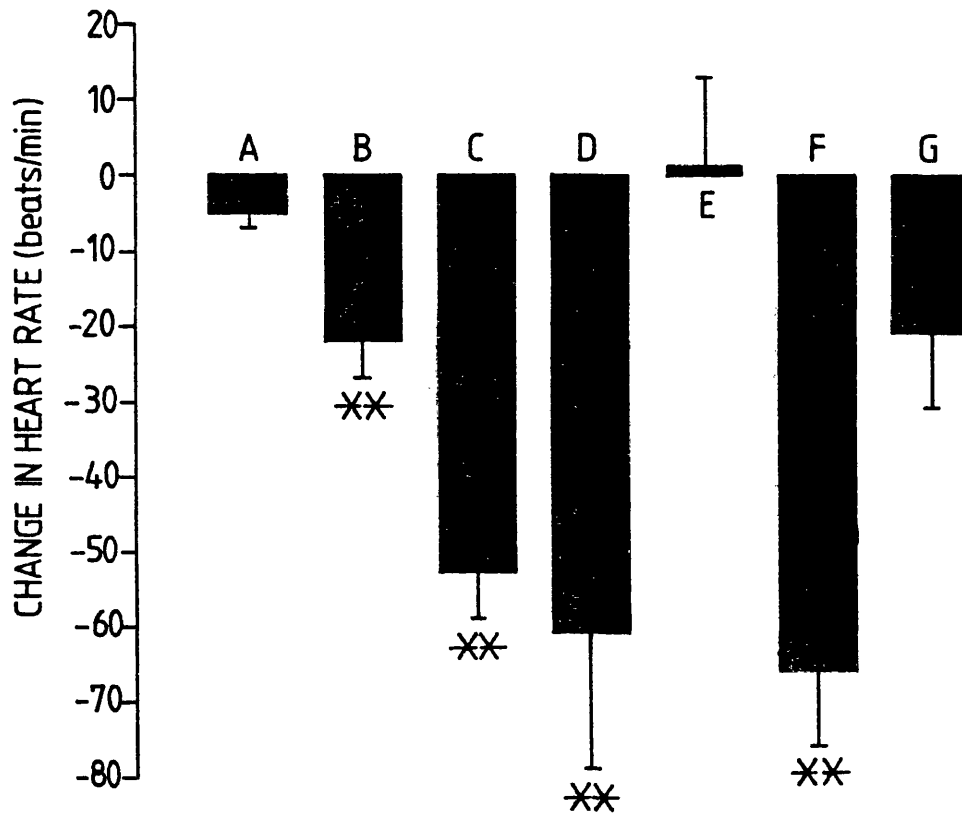

FIGURE 10 Effect on heart rate of thiobutobarbitone anaesthetised rats of icv injections of:

- A artificial CSF vehicle (10 µl)
- B dl-propranolol (10 µg)
- C dl-propranolol (30 µg)
- D dl-propranolol (100 µg)
- E d-propranolol (30 µg)
- F atenolol (100 µg)
- G ICI 118551 (100 µg)

The change in heart rate (\pm sem) from pretreatment control value is shown at 15 minutes after the start of the injection. The injection lasted 5 minutes. Groups consisted of 7 animals except the atenolol (6) and d-propranolol (5) groups. Significant difference from pretreatment control denoted: * $P < 0.05$ ** $P < 0.01$

FIGURE 11 (Overpage)

- A Effect of intravenous propranolol on the tachycardic response to intravenous isoprenaline (0.1 μ g)
- B Tachycardic response to intravenous isoprenaline (0.1 μ g) five minutes after the icv injection of 100 μ g dl-propranolol (equivalent to time 15 minutes in Figure 8).

Animals were anaesthetised with halothane.
Figures in parentheses indicate the number of animals.
Values expressed as mean \pm sem.

FIGURE 11

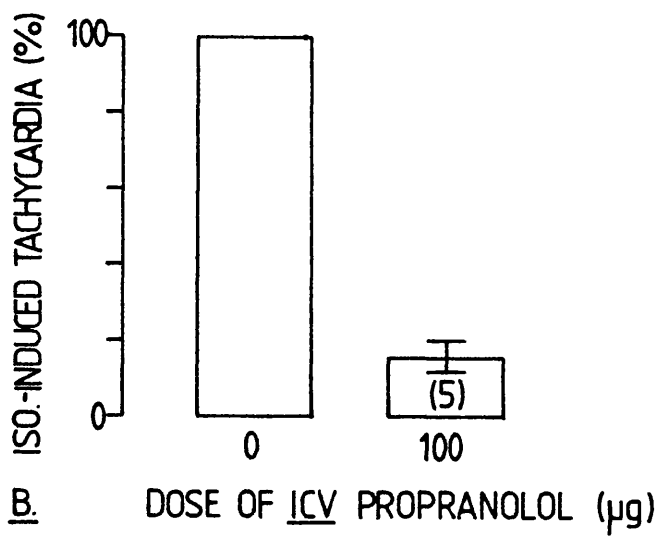
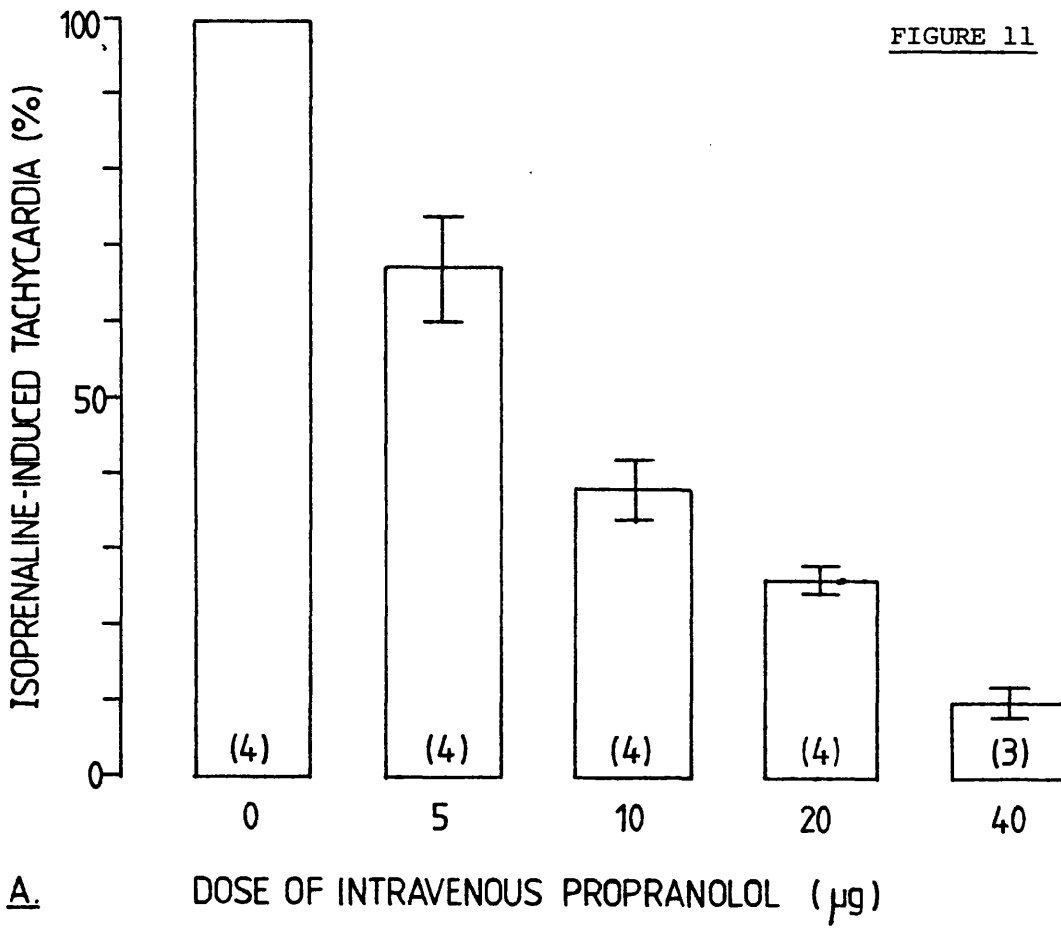

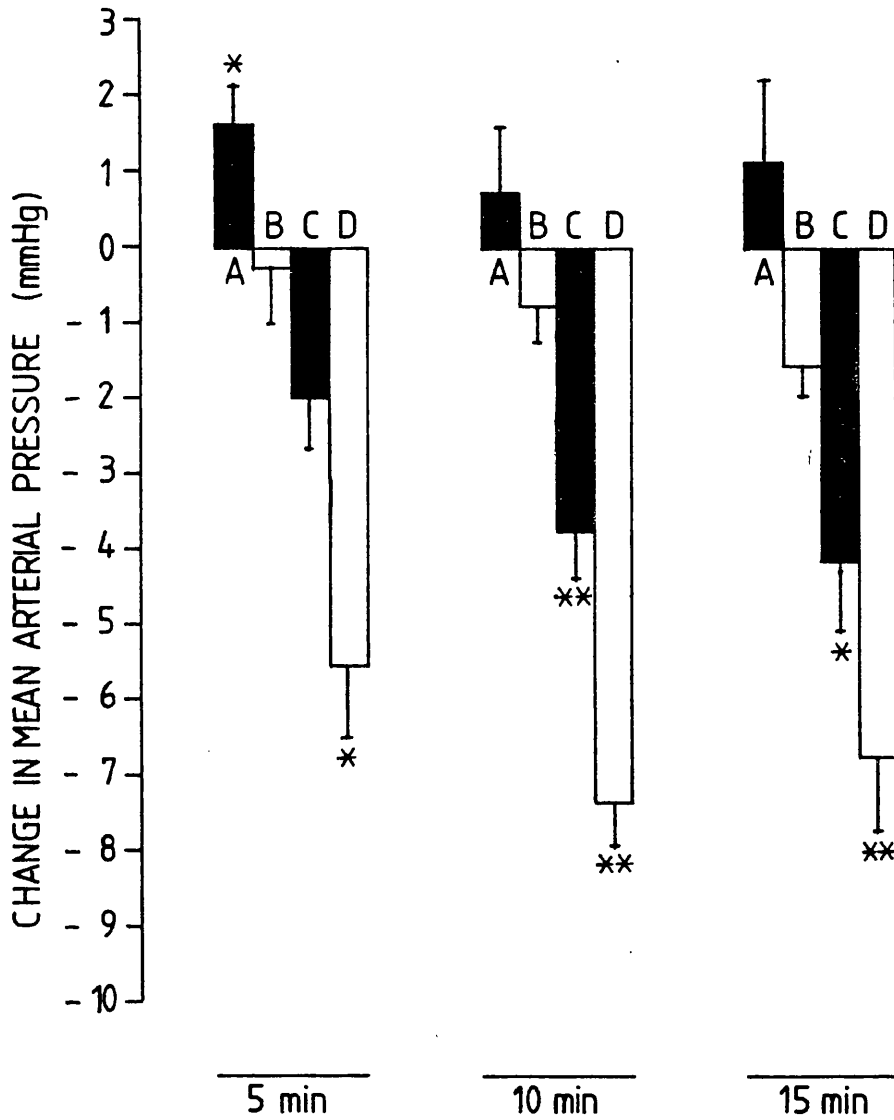

FIGURE 12

Effect of 0.4 μ l saline vehicle (A), 2 μ g d-propranolol (B), 1 μ g l-propranolol (C) and 2 μ g l-propranolol (D) on mean arterial pressure following intrahippocampal injection in halothane anaesthetised rats. Changes in mean pressure (\pm sem) are shown 5, 10 and 15 minutes after the start of the injection. Injections lasted 4 minutes. 5 animals in each group. Significant difference from pretreatment control denoted: * $P < 0.05$ ** $P < 0.01$

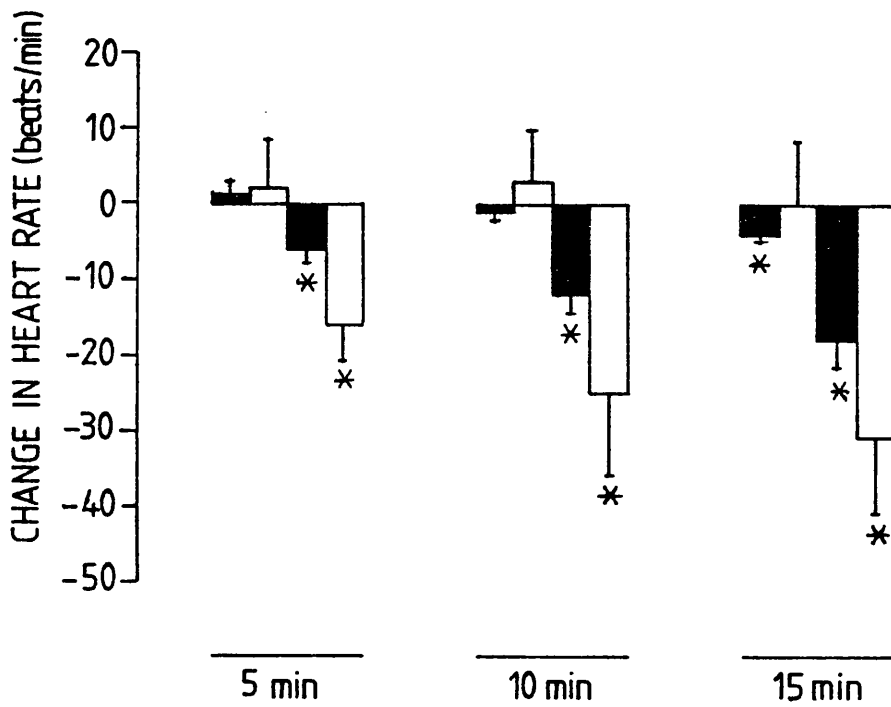

FIGURE 13 Effect of 0.4 µl saline vehicle (A), 2 µg d-propranolol (B), 1 µg l-propranolol (C) and 2 µg l-propranolol (D) on heart rate following intrahippocampal injection in halothane anaesthetised rats. Changes in heart rate (\pm sem) are shown 5, 10 and 15 minutes after the start of the injection. Injections lasted 4 minutes. 5 animals in each group. Significant difference from pretreatment control denoted: * $P < 0.05$

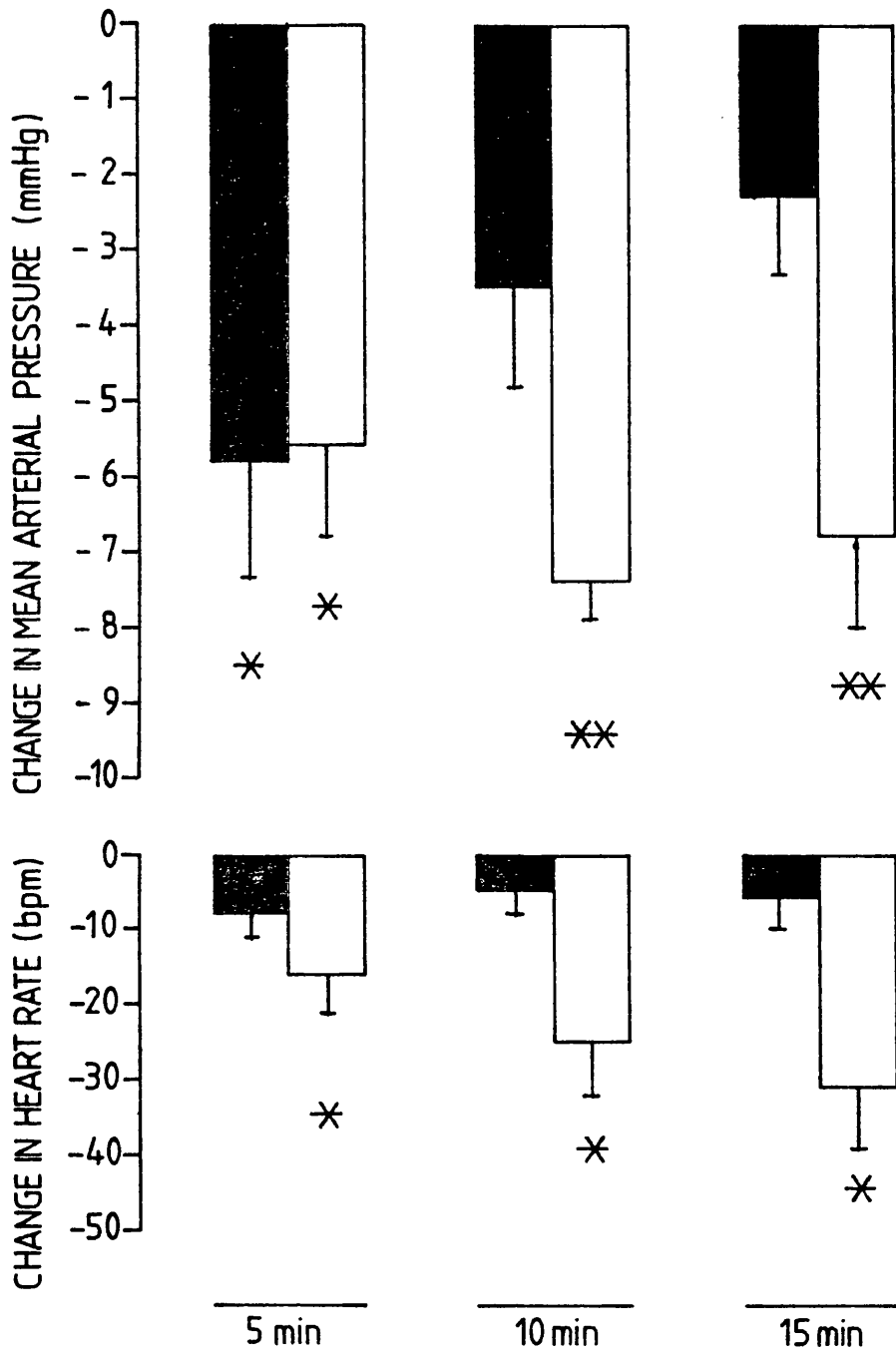

FIGURE 14

Comparison of effects of intravenous (shaded histograms) and intrahippocampal (open histograms) injections of 2 µg l-propranolol on mean arterial pressure and heart rate in the halothane anaesthetised rat. Changes in both parameters (\pm sem) are shown 5, 10 and 15 minutes after the start of the injection. Central injections lasted 4 minutes. 5 animals in each group. Significant difference from pretreatment control denoted: * $P < 0.05$ ** $P < 0.01$

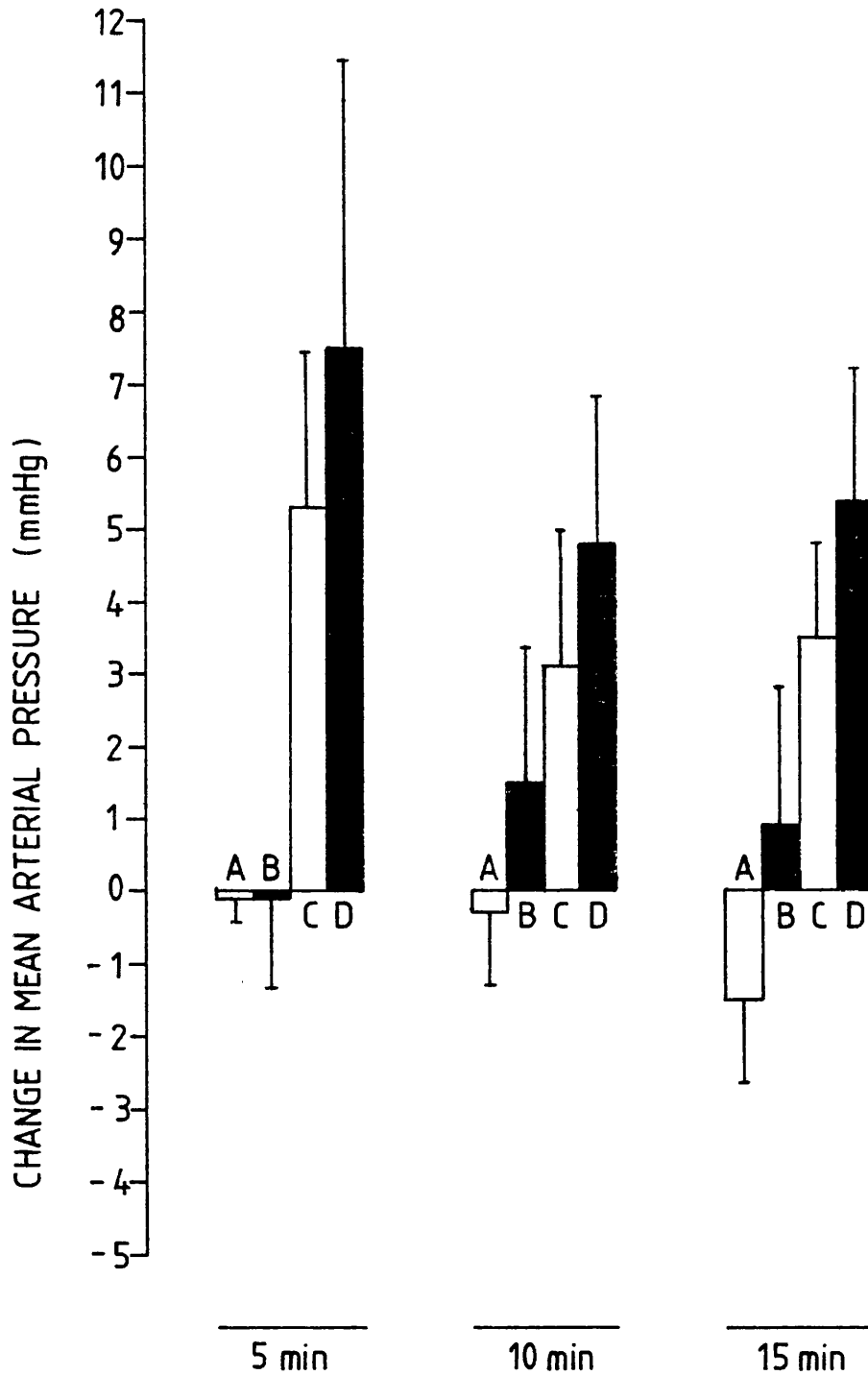

FIGURE 15

Effect on mean arterial pressure of intrahippocampal injection of 2 µg timolol (A), 2 µg atenolol (B), 1 µg isoprenaline (C) and 2 µg isoprenaline (D) in the halothane anaesthetised rat. Vehicle = 0.4 µl saline. Changes in mean arterial pressure (\pm sem) are shown 5, 10 and 15 minutes after the start of injection. Injections lasted 4 minutes. 5 animals in each group. No significant changes were observed following any of the treatments.

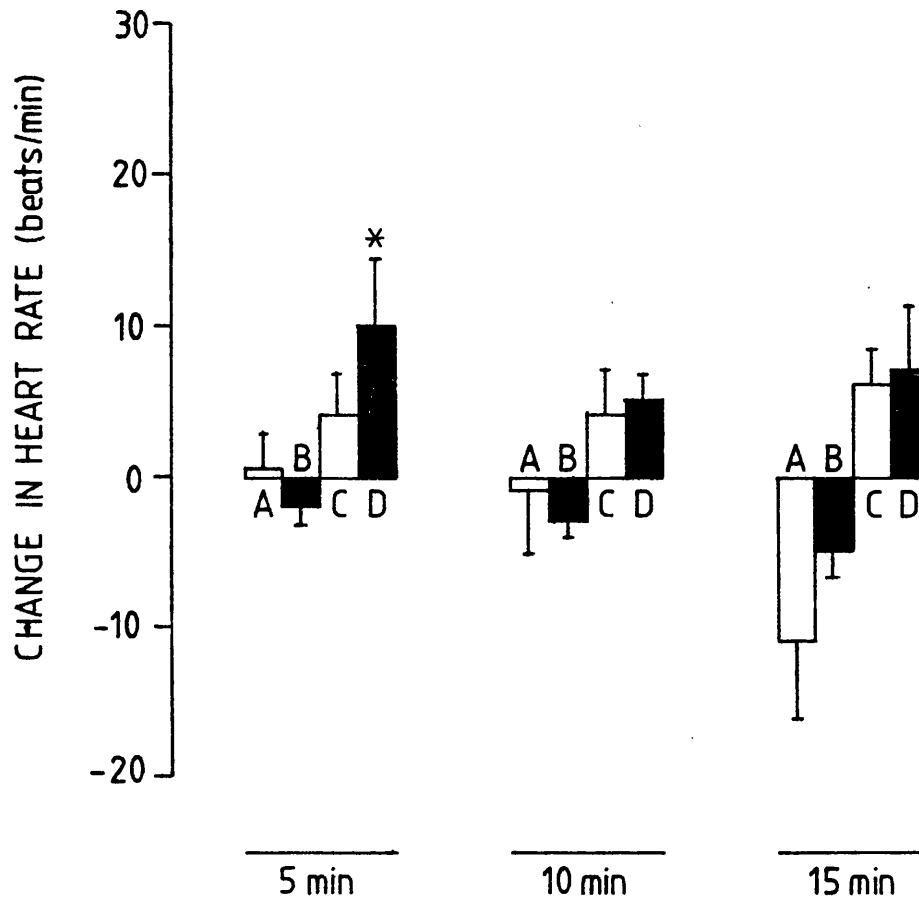

FIGURE 16 Effect on heart rate of intrahippocampal injections of 2 µg timolol (A), 2 µg atenolol (B), 1 µg isoprenaline (C) and 2 µg isoprenaline (D) in the halothane anaesthetised rat. Vehicle = 0.4 µl saline. Changes in heart rate (\pm sem) are shown 5, 10 and 15 minutes after the start of the injection. Injections lasted 4 minutes. 5 animals in each group. Significant difference from pretreatment control is denoted: * $P < 0.05$

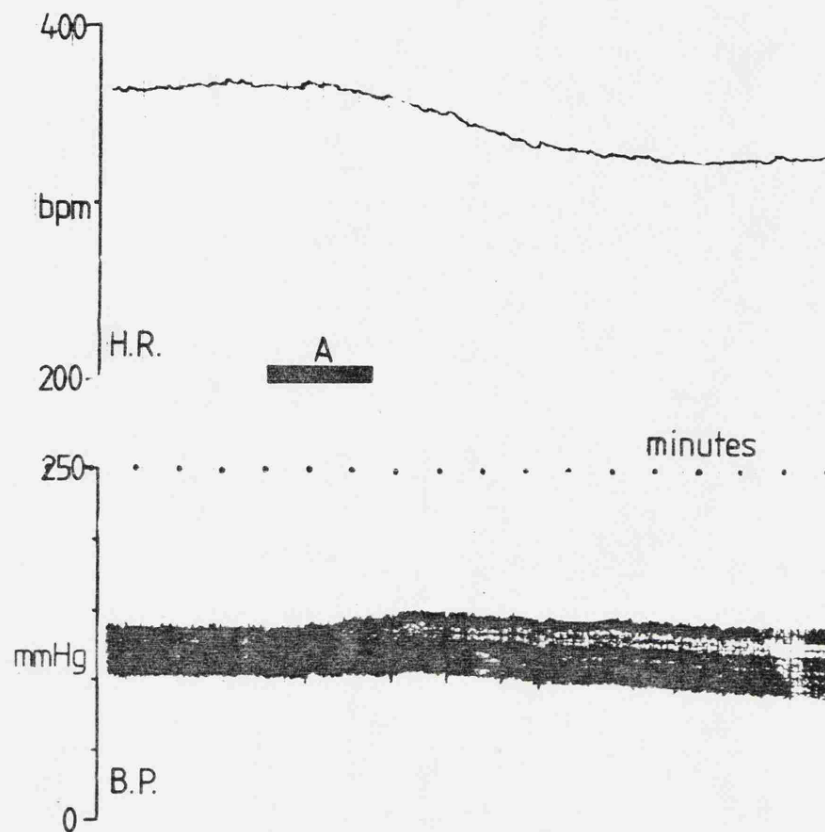

FIGURE 17 Effect on heart rate (HR) and blood pressure (BP) of a thiobutobarbitone anaesthetised rat of an icv injection of adrenaline (20 μ g) following pretreatment with icv artificial CSF (10 μ l). Adrenaline (A) injection indicated by horizontal bar.

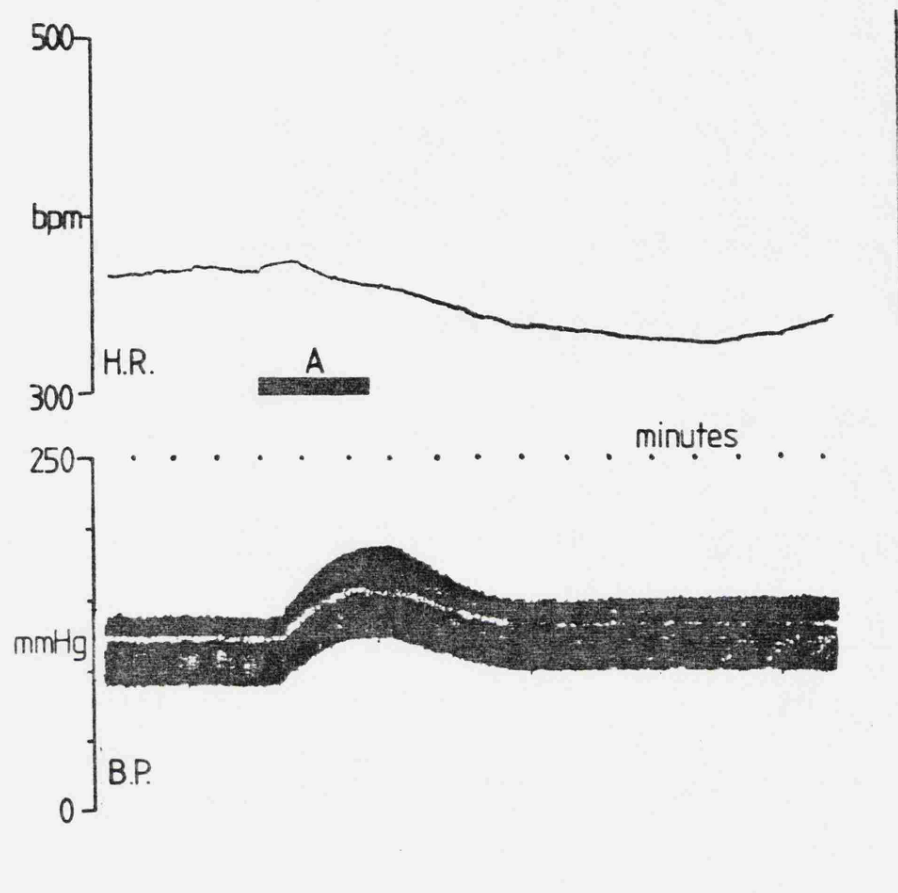

FIGURE 18 Effect on heart rate (HR) and blood pressure (BP) of a thiobutobarbitone anaesthetised rat of an icv injection of adrenaline (20 μ g) following pretreatment with icv dl-propranolol (30 μ g). Adrenaline (A) injection indicated by horizontal bar.

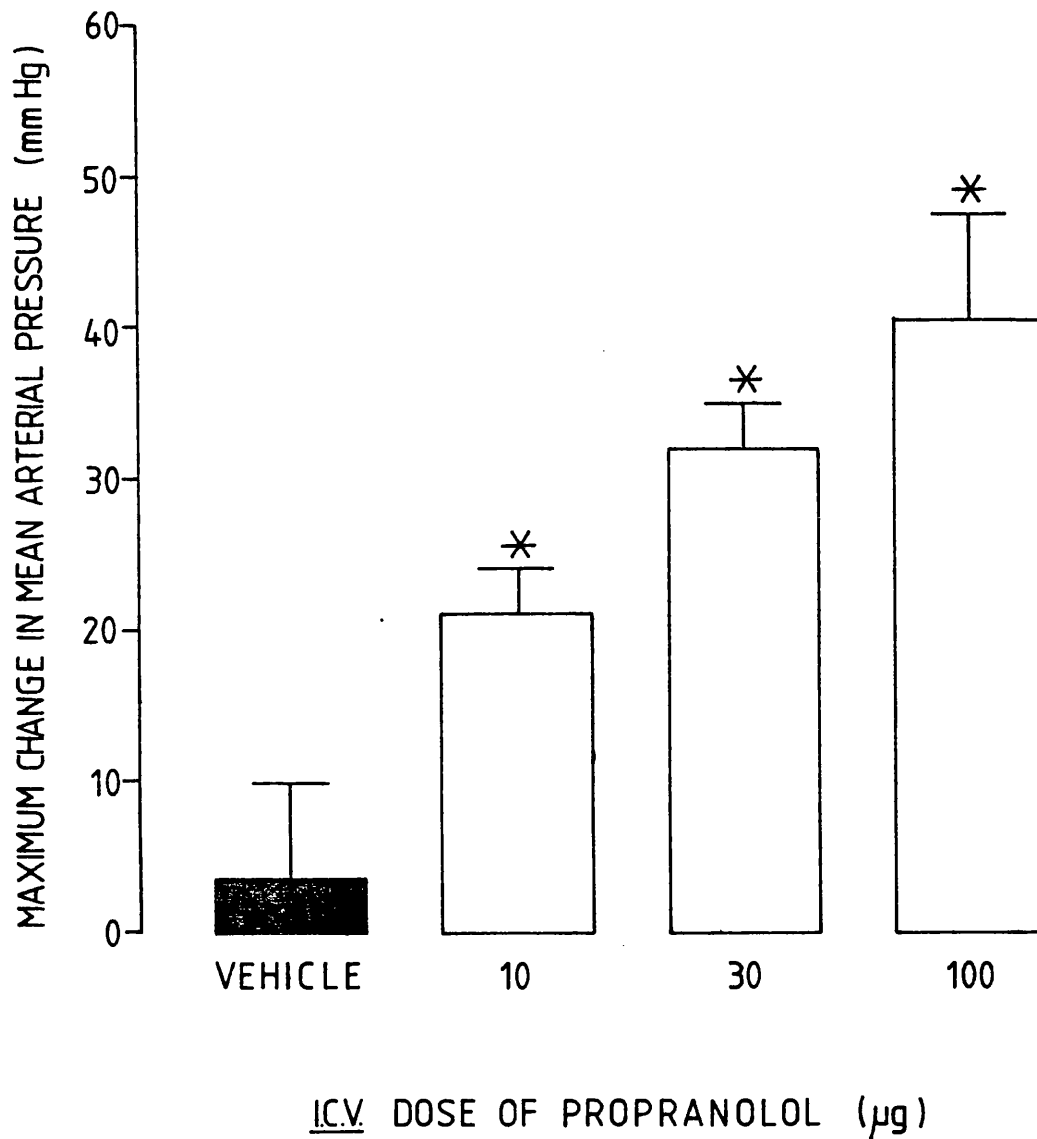

FIGURE 19

Maximum mean arterial pressure changes evoked by icv adrenaline ($20 \mu\text{g}$) following icv pretreatment with vehicle ($10 \mu\text{l}$ artificial CSF) and 10, 30 and $100 \mu\text{g}$ dl-propranolol. Thiobutobarbitone anaesthetised rats, 7 animals per group. Significant difference from pretreatment control denoted: * $P < 0.001$

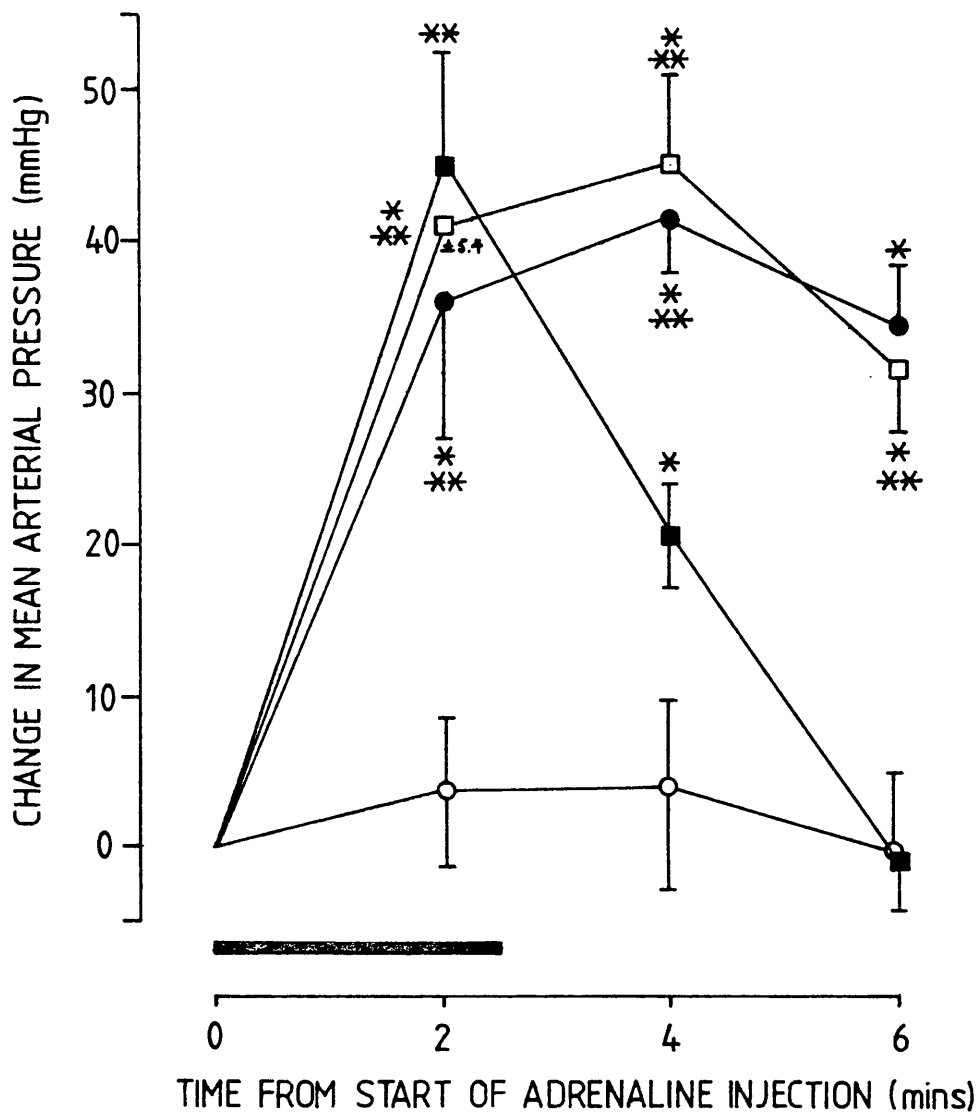

FIGURE 20

Time course and magnitude of the mean arterial pressure changes (\pm sem) evoked by icv adrenaline (20 μ g) following icv pretreatment with 100 μ g atenolol (■), 100 μ g dl-propranolol (●), 100 μ g ICI 118551 (□) and vehicle (10 μ l artificial CSF, ○). Thiobutobarbitone anaesthetised rats, 7 animals per group. Adrenaline injection indicated by horizontal bar. Significant difference from pretreatment control denoted: * $P < 0.02$ ** $P < 0.01$ *** $P < 0.001$

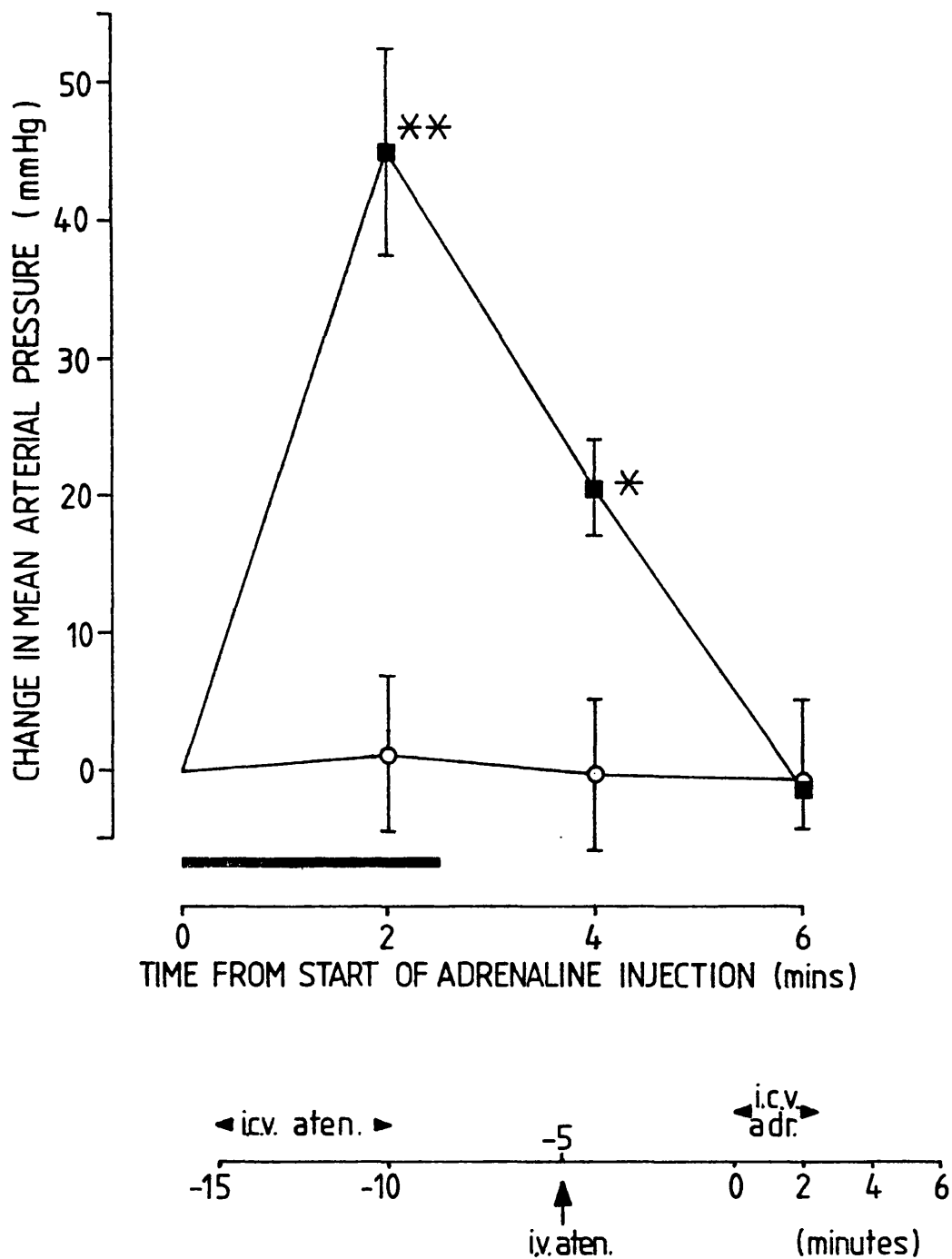

FIGURE 21 Time course and magnitude of the mean arterial pressure changes (\pm sem) evoked by icv adrenaline (20 μ g) following either pretreatment with 100 μ g atenolol icv (■) or pretreatment with 100 μ g atenolol i.v. (o). Injection schedules are indicated. Adrenaline injection indicated by horizontal bar. Thiobutobarbitone anaesthetised rats, 7 animals per group. Significant difference from pretreatment control denoted:
 * $P < 0.02$ ** $P < 0.01$

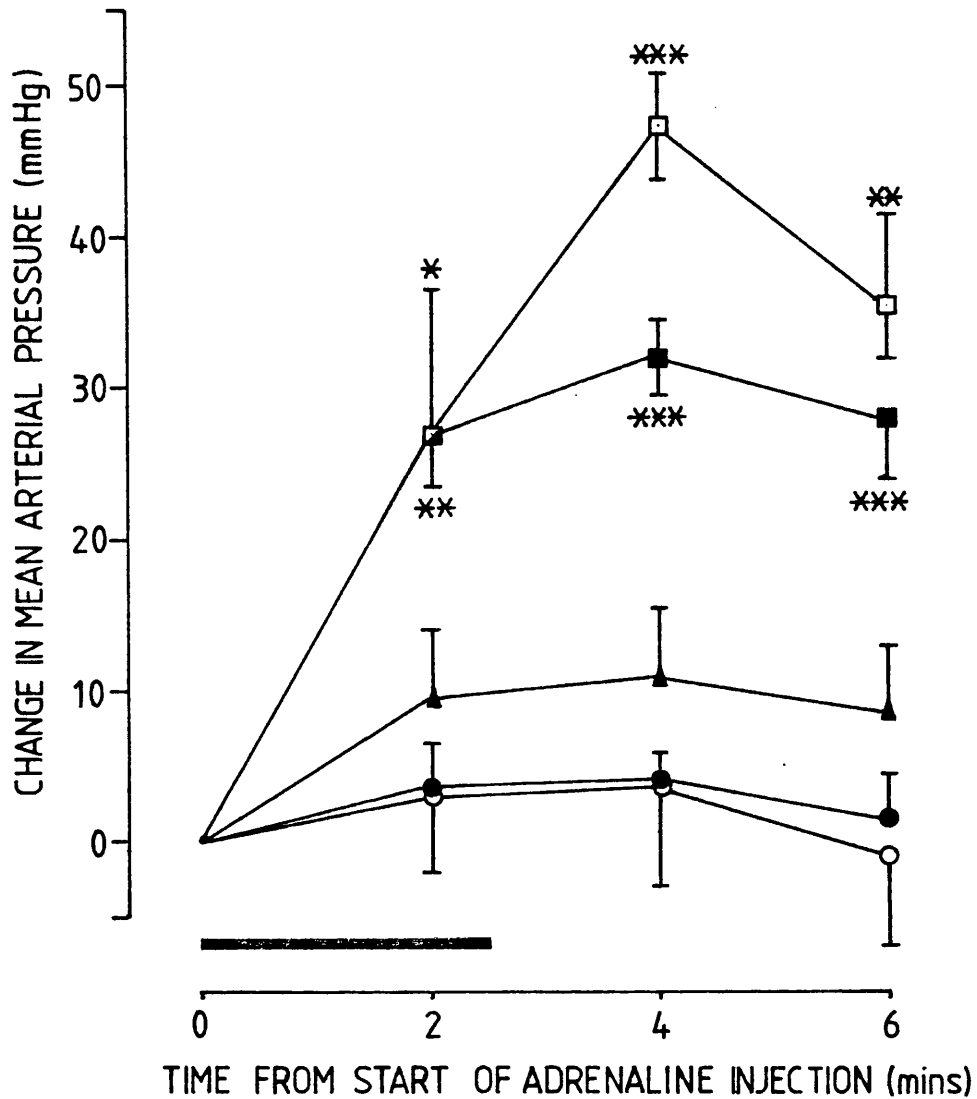

FIGURE 22 Time course and magnitude of the mean arterial pressure changes (\pm sem) evoked by icv adrenaline (20 μ g) following icv pretreatment with 30 μ g ICI 118551 (□), 30 μ g dl-propranolol (■), 30 μ g atenolol (▲), 30 μ g d-propranolol (●) and vehicle (10 μ l artificial CSF, ○). Adrenaline injection indicated by horizontal bar. Thiobutobarbitone anaesthetised rats, 6 animals per group except the dl- (7) and d-propranolol (5) groups. Significant difference from pretreatment control denoted: * $P < 0.05$ ** $P < 0.01$ *** $P < 0.001$

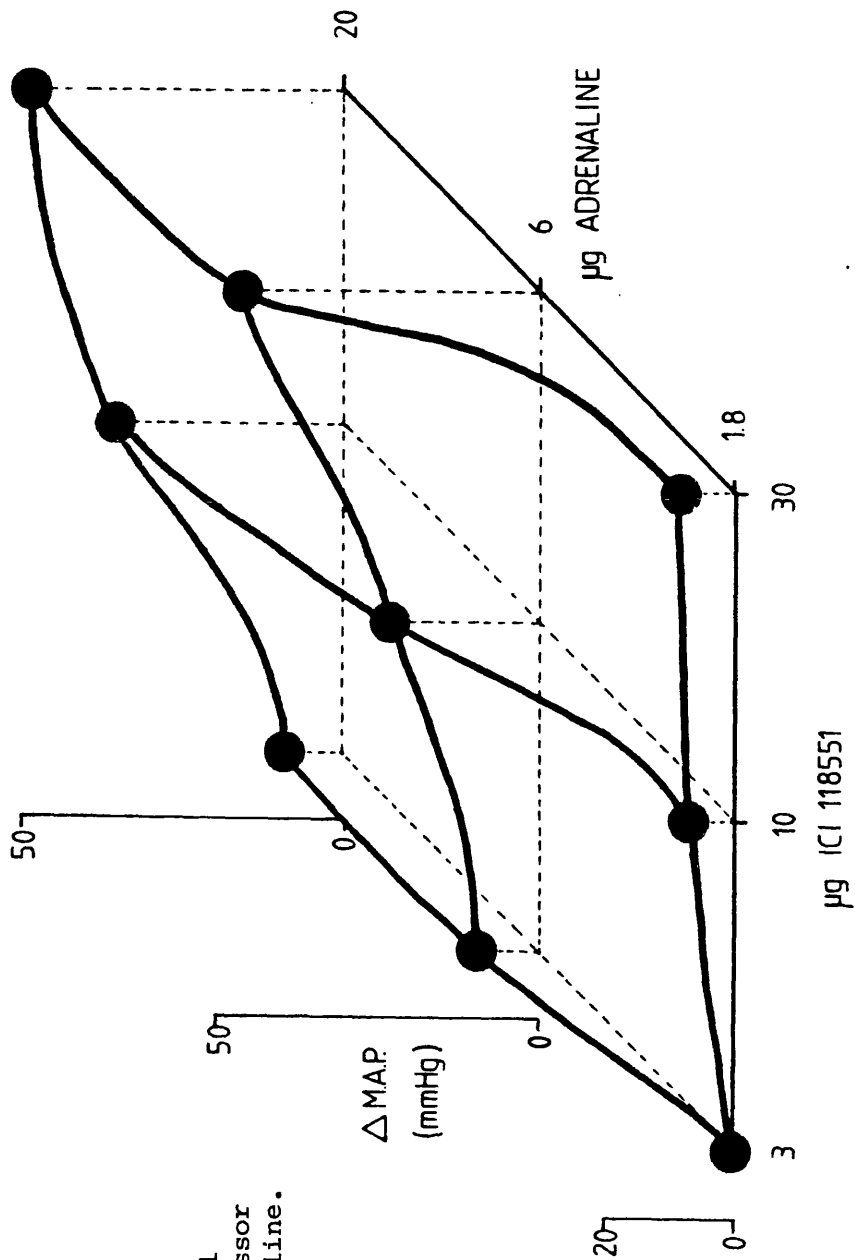

FIGURE 23 Effect of icv ICI 118551 pretreatment on the pressor responses to icv adrenaline. Change in mean arterial pressure from pre-adrenaline injection control is denoted Δ MAP. Thiobutobarbitone anaesthetised rats, 4-7 animals per group.

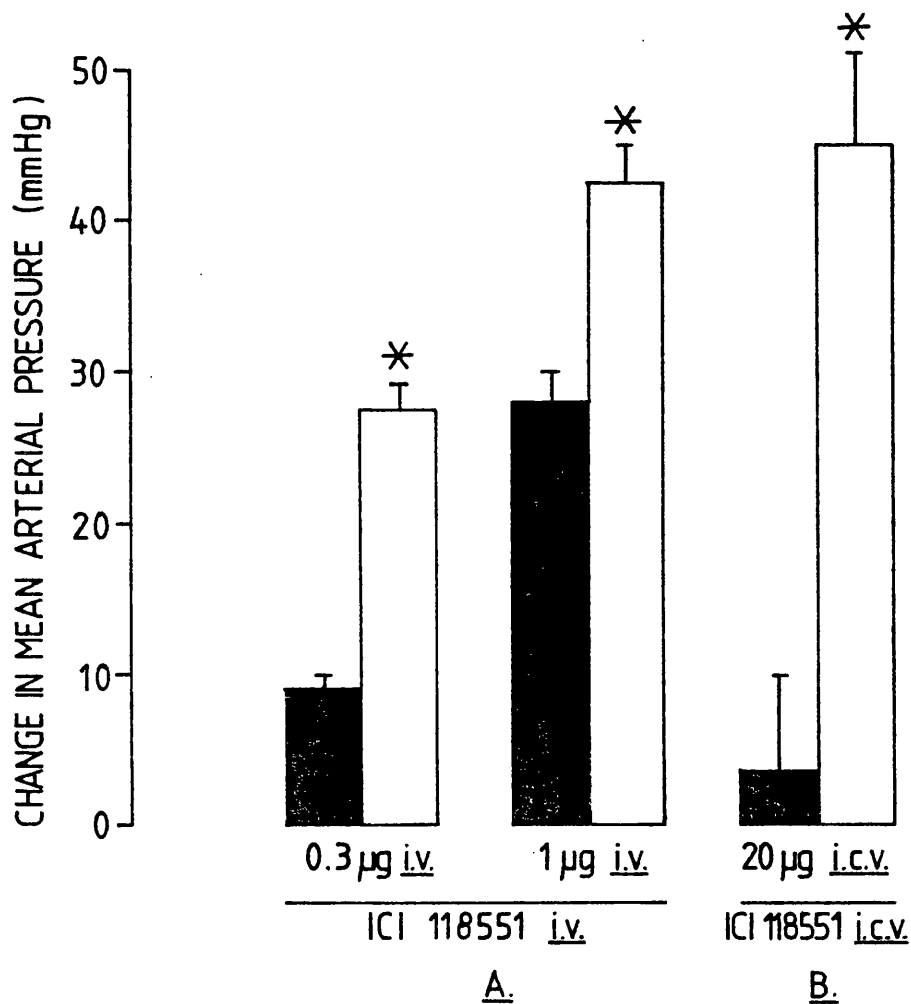

FIGURE 24 A. Change in mean arterial pressure (\pm sem) evoked by intravenous adrenaline (0.3, 1.0 μ g) before (shaded histobars) and after (open histobars) intravenous ICI 118551 (30 μ g).
 B. Change in mean arterial pressure (\pm sem) evoked by icv adrenaline (20 μ g) after icv pretreatment with either vehicle (10 μ l artificial CSF - shaded histobar) or 30 μ g ICI 118551 (open histobar).

Thiobutobarbitone anaesthetised rats, 7 animals per group. Significant increases in the response to adrenaline following ICI 118551 treatment are denoted: * $P < 0.001$

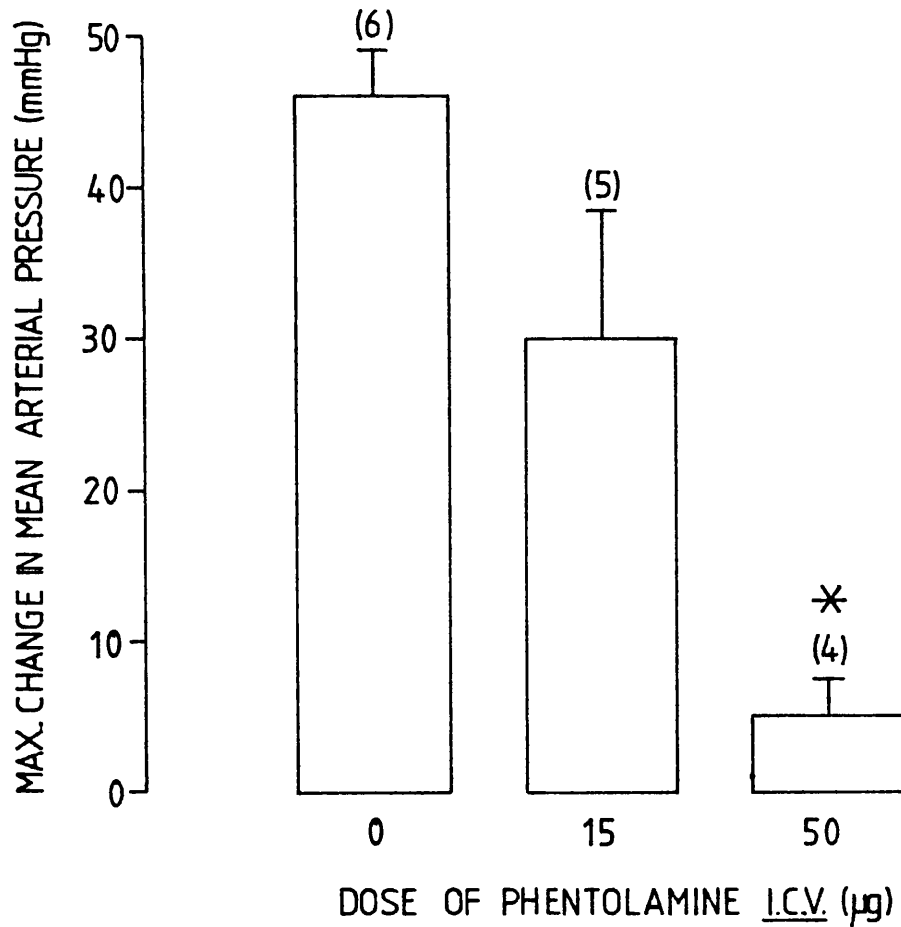

FIGURE 25

Effect of icv phentolamine (15, 50 µg) on the maximum change in mean arterial pressure (\pm sem) produced by icv adrenaline (6 µg) following pretreatment with ICI 118551 (30 µg).

Injection schedule: 0-2.5 min - phentolamine
 10-15 min - ICI 118551
 25-27.5 min - adrenaline

Thiobutobarbitone anaesthetised rats; numbers of animals per group indicated by figures in parentheses. Significant decrease in the pressor response to icv adrenaline denoted: * $P < 0.001$

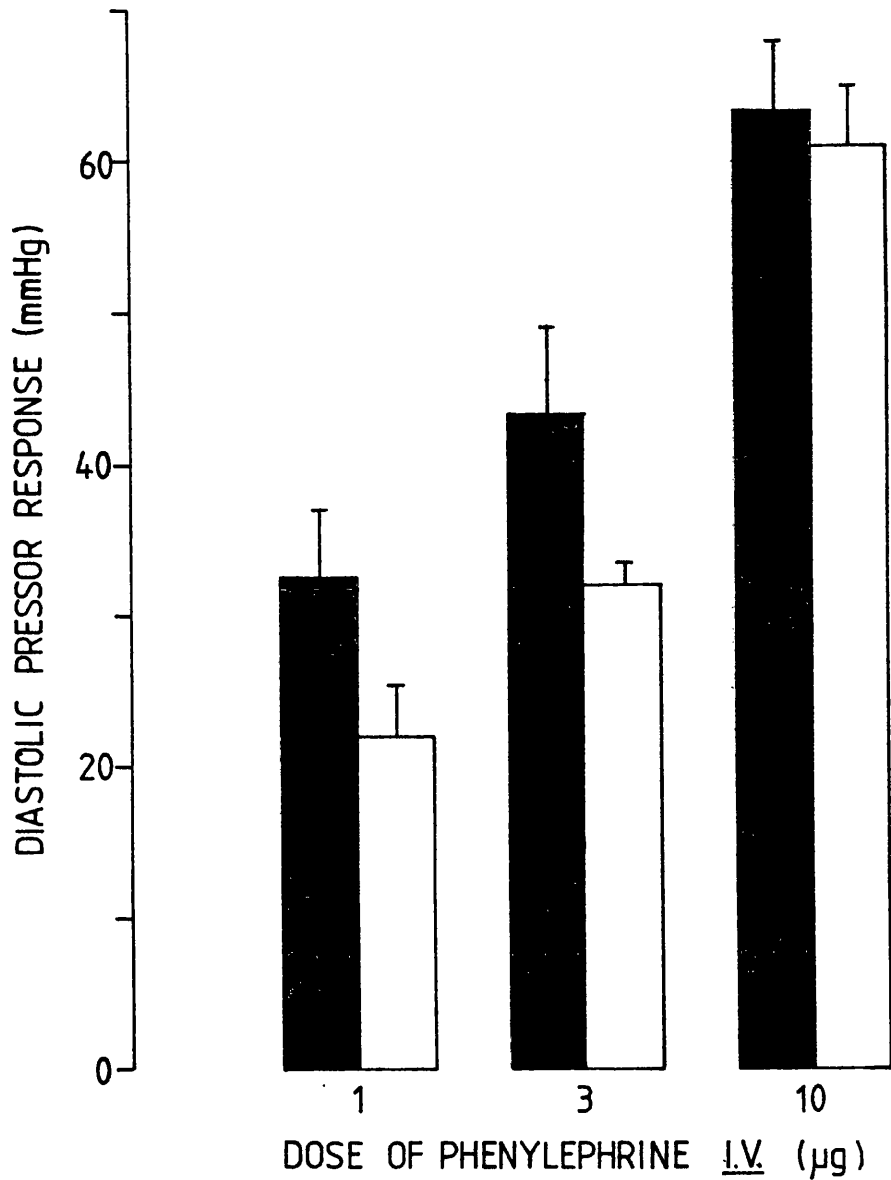

FIGURE 26 Effect of intravenous phenylephrine (1, 3 and 10 μg) on diastolic blood pressure ($\pm\text{sem}$) before (shaded histobars) and 25 minutes after (open histobars) icv injection of 50 μg phentolamine (Cf. injection schedule outlined in Figure 25). Thiobutobarbitone anaesthetised rats, 3 animals per group. No significant differences detected between groups at each dose level.

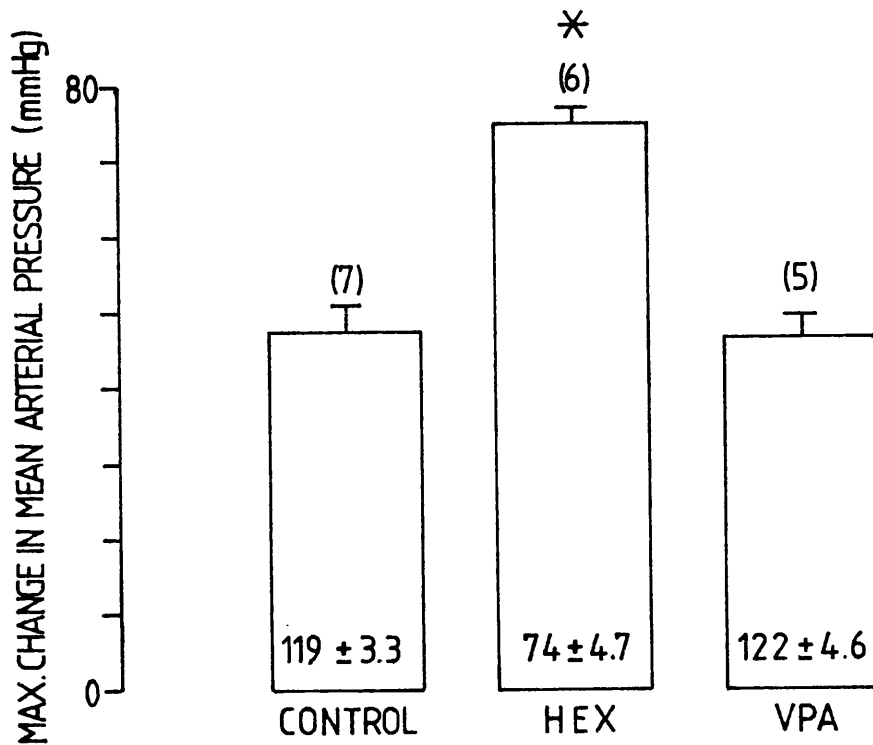

FIGURE 27 CONTROL Maximum change in mean arterial pressure (\pm sem) evoked by icv adrenaline (20 μ g) following pretreatment with icv ICI 118551 (30 μ g).

HEX Effect of intravenous hexamethonium (3 mg) on the CONTROL response.

VPA Effect of intravenous vasopressin antagonist (20 μ g) on the CONTROL response.

Injection schedule: 0 - 5 min icv ICI 118551
 10 min i.v. HEX or VPA
 15 - 17.5 min icv adrenaline

Mean arterial pressures (\pm sem) immediately before the adrenaline injections are indicated in the histograms. Thiobutobarbitone anaesthetised rats; figures in parentheses indicate numbers of animals per group. Significant difference from control pressor response is denoted * $P < 0.001$

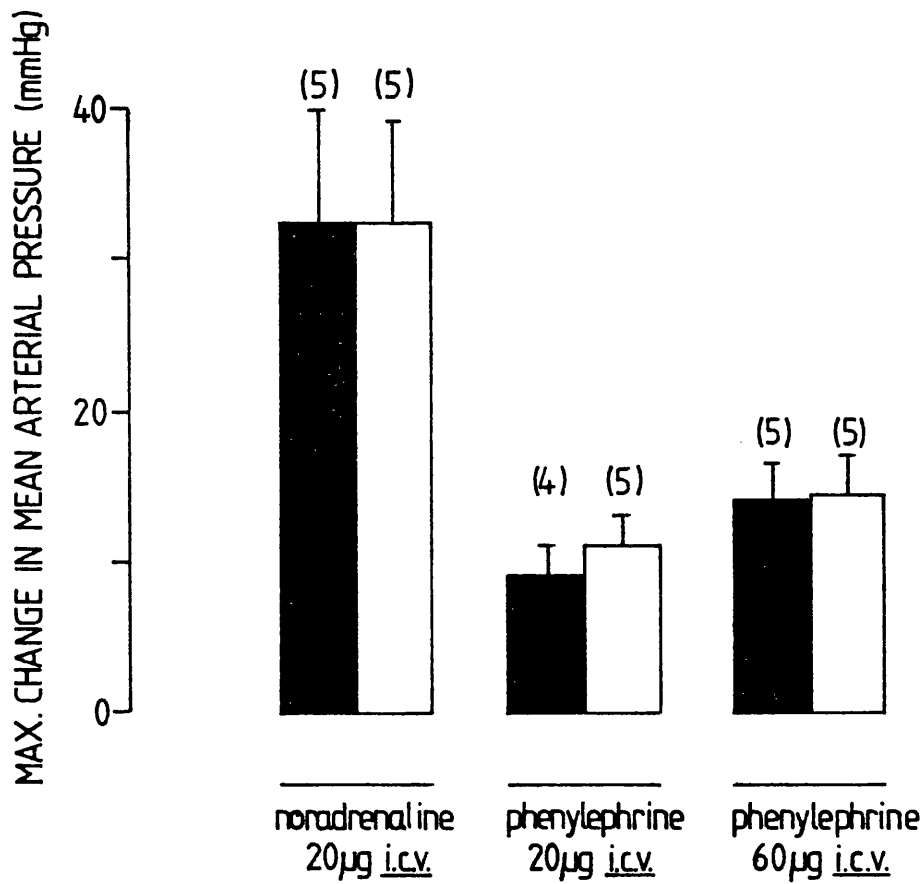

FIGURE 28

Maximum changes in mean arterial pressure (\pm sem) produced by icv noradrenaline (20 μ g) and icv phenylephrine (20,60 μ g) following icv pretreatment with either vehicle (10 μ l artificial CSF - shaded histobars) or 30 μ g ICI 118551 (open histobars).

ICI 118551 did not influence the responses to either of the agonists.

Thiobutobarbitone anaesthetised rats; figures in parentheses indicate numbers of animals in each group.

(Overpage)

- FIGURE 29 A. Effect on systolic blood pressure (\pm sem) of electrical stimulation in the anterior hypothalamus.
- B. Effect on systolic blood pressure (\pm sem) of electrical stimulation in the anterior hypothalamus before (shaded histobars) and after (open histobars) icv injection of dl-propranolol (50 μ g)

Thiobutobarbitone anaesthetised rats, 3 animals per group.

Significant difference from pretreatment control response denoted: * $P < 0.01$

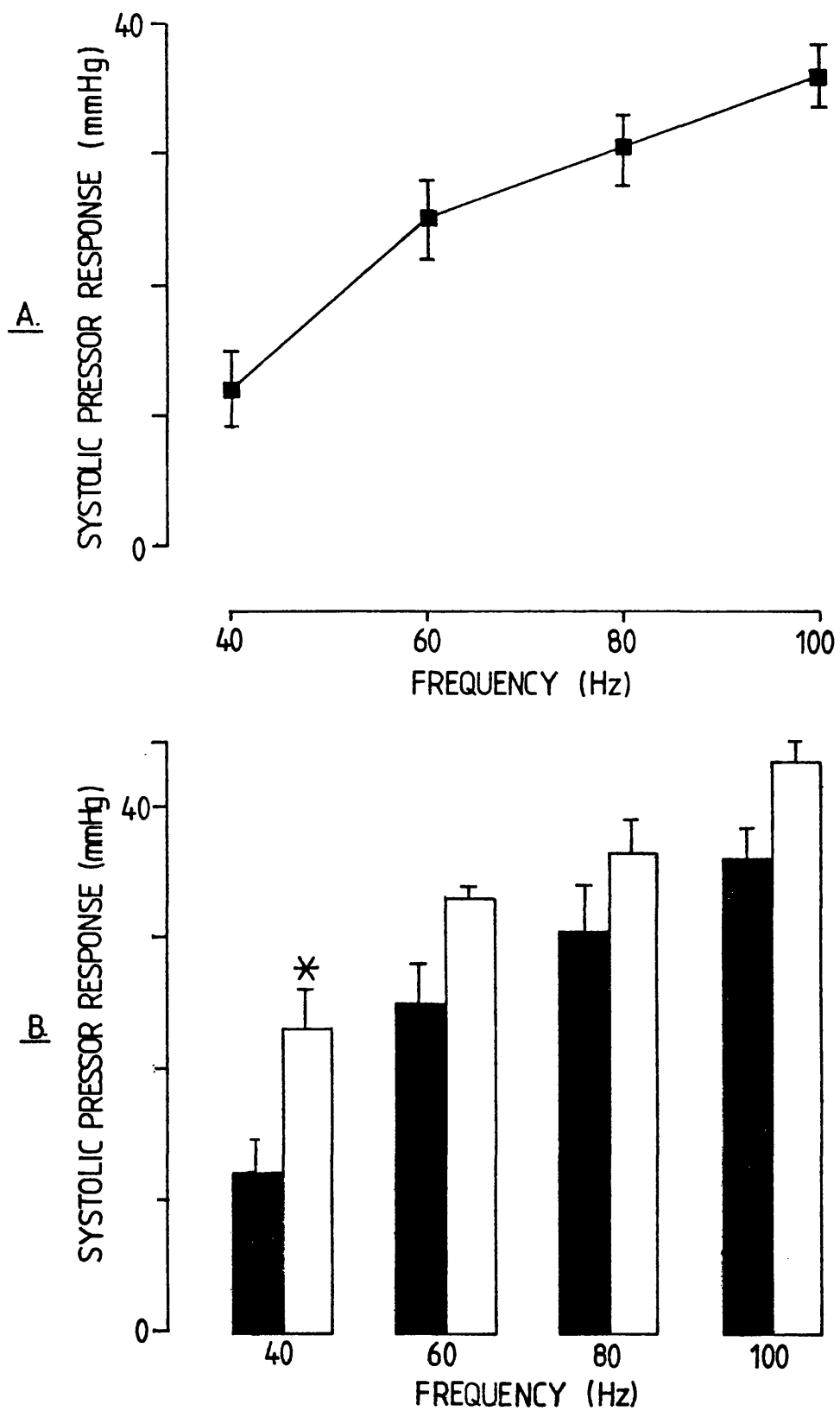

FIGURE 29

(Overpage)

- FIGURE 30 A. Effect on systolic blood pressure (\pm sem) of electrical stimulation in the posterior hypothalamus.
- B. Effect on systolic blood pressure (\pm sem) of electrical stimulation in the posterior hypothalamus before (shaded histobars) and after (open histobars) icv injection of dl-propranolol (100 μ g).

Thiobutobarbitone anaesthetised rats, 5 animals per group.

No statistical differences were detected.

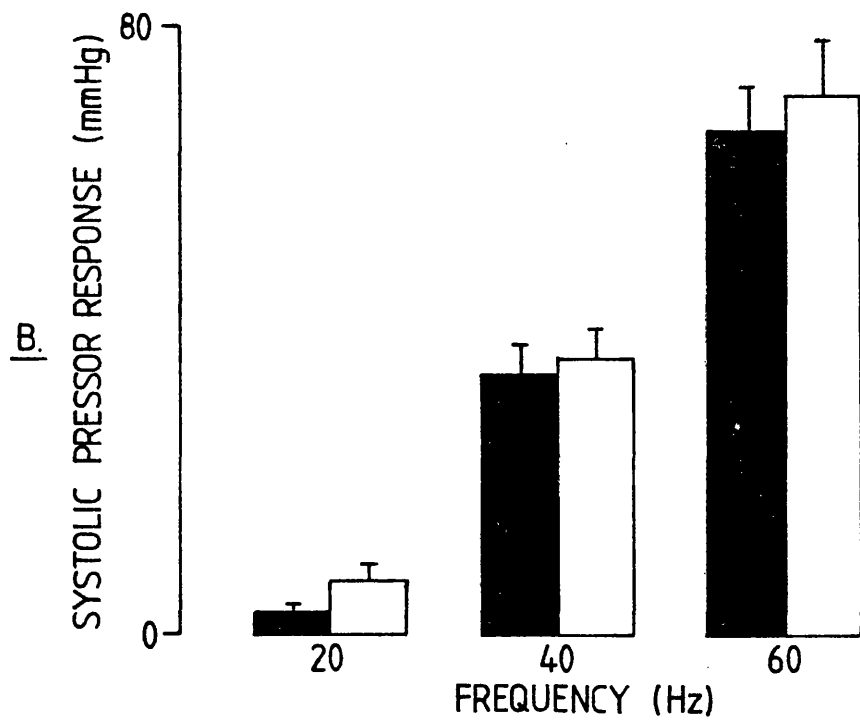
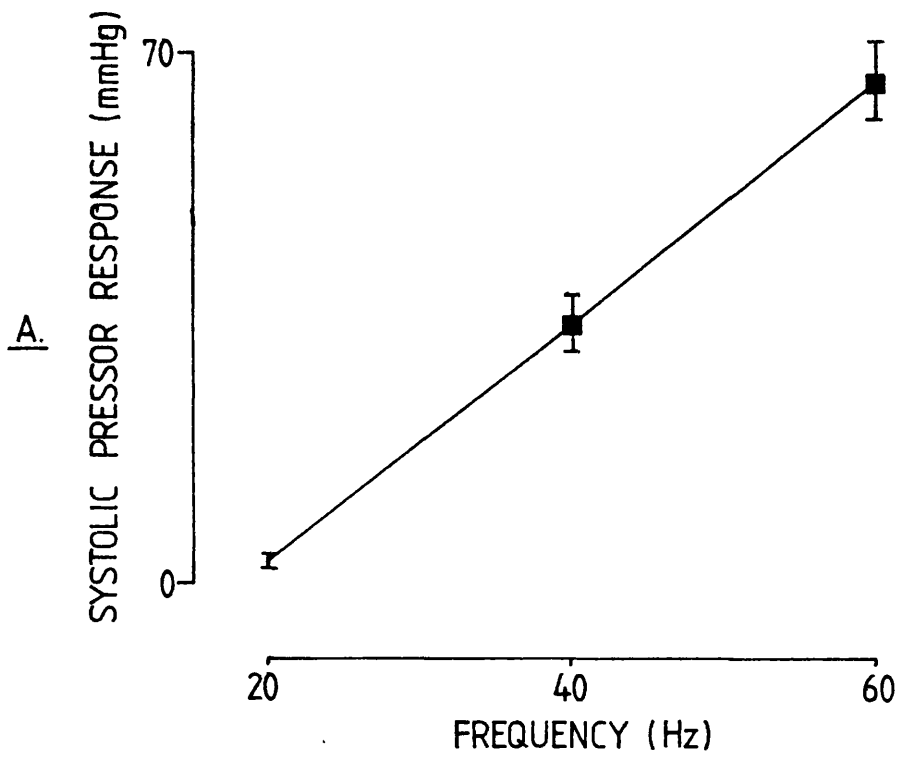
FIGURE 30

(Overpage)

- FIGURE 31 A. Effect on systolic blood pressure (\pm sem) of electrical stimulation in the amygdala.
- B. Effect on systolic blood pressure (\pm sem) of electrical stimulation in the amygdala before (shaded histobars) and after (open histobars) icv injection of dl-propranolol (50 μ g)

Thiobutobarbitone anaesthetised rats, 4 animals per group.

No statistical differences were detected between responses in treated and untreated groups.

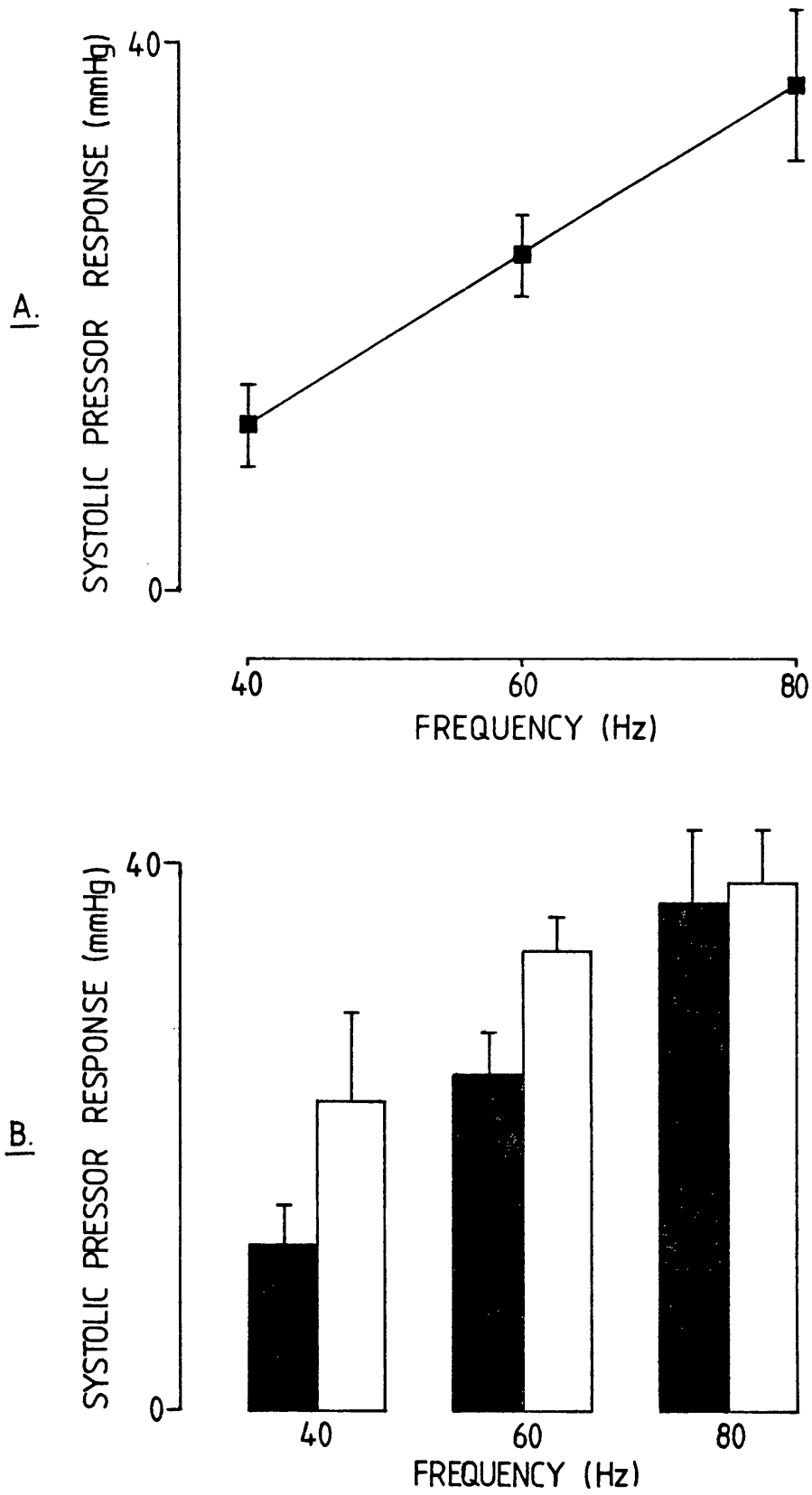

FIGURE 31

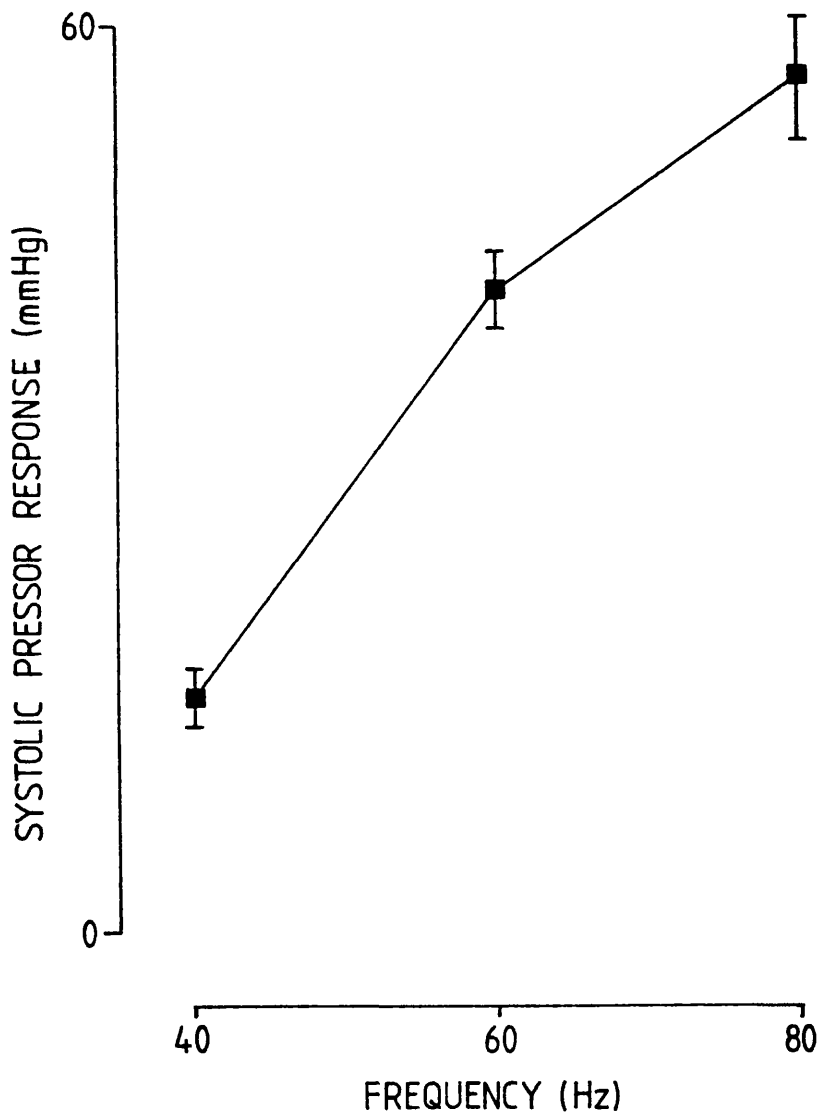

FIGURE 32 Effect on systolic blood pressure (\pm sem) of electrical stimulation in the median raphe nucleus.

Thiobutobarbitone anaesthetised rats, 15 animals per determination.

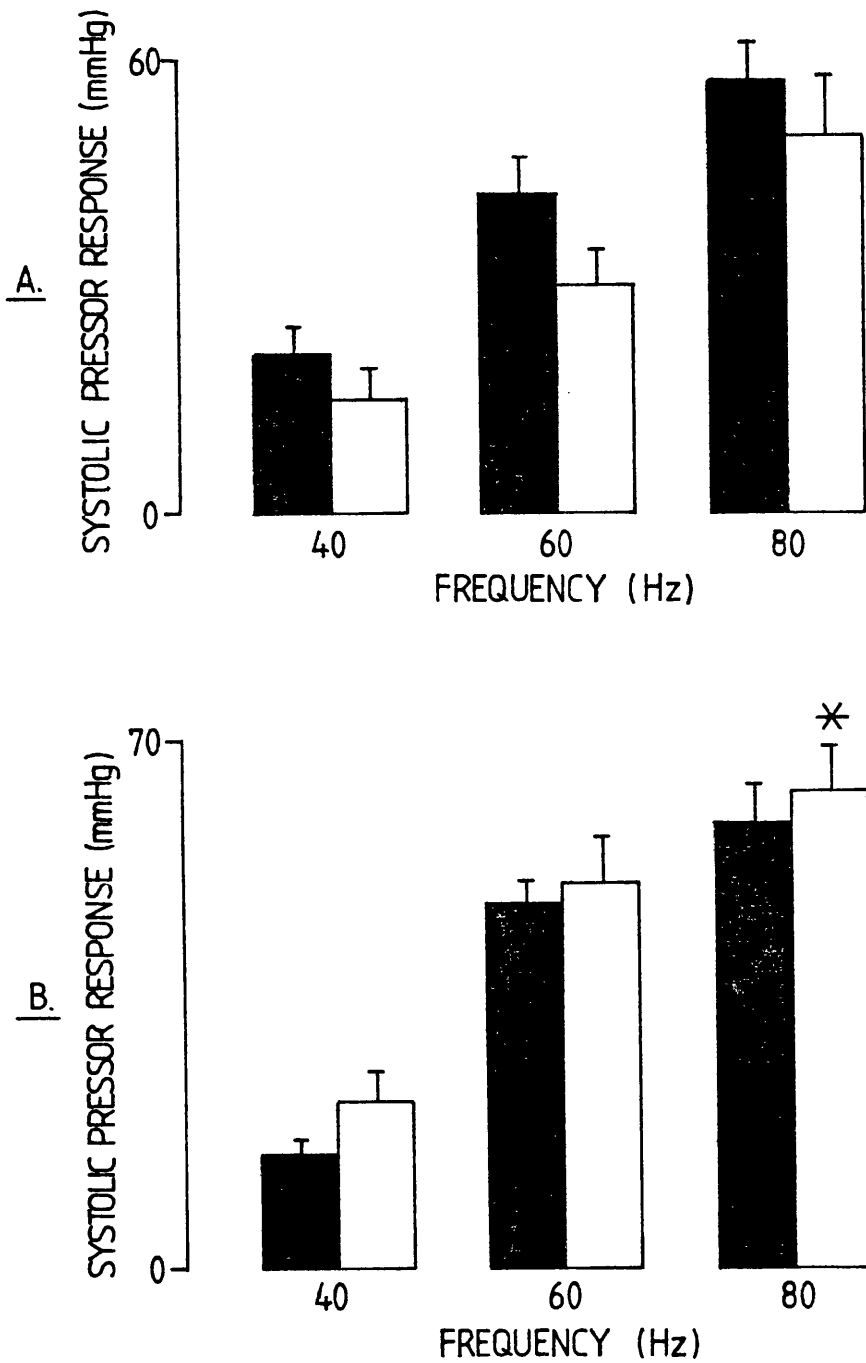

FIGURE 33 Effect on systolic blood pressure (\pm sem) of electrical stimulation in the median raphe nucleus before (shaded histobars) and after (open histobars) icv injection of either 50 μ g dl-propranolol (A) or 50 μ g atenolol (B).

Significant difference from pretreatment control denoted: * $P < 0.05$.

Thiobutobarbitone anaesthetised rats, 5 animals per group.

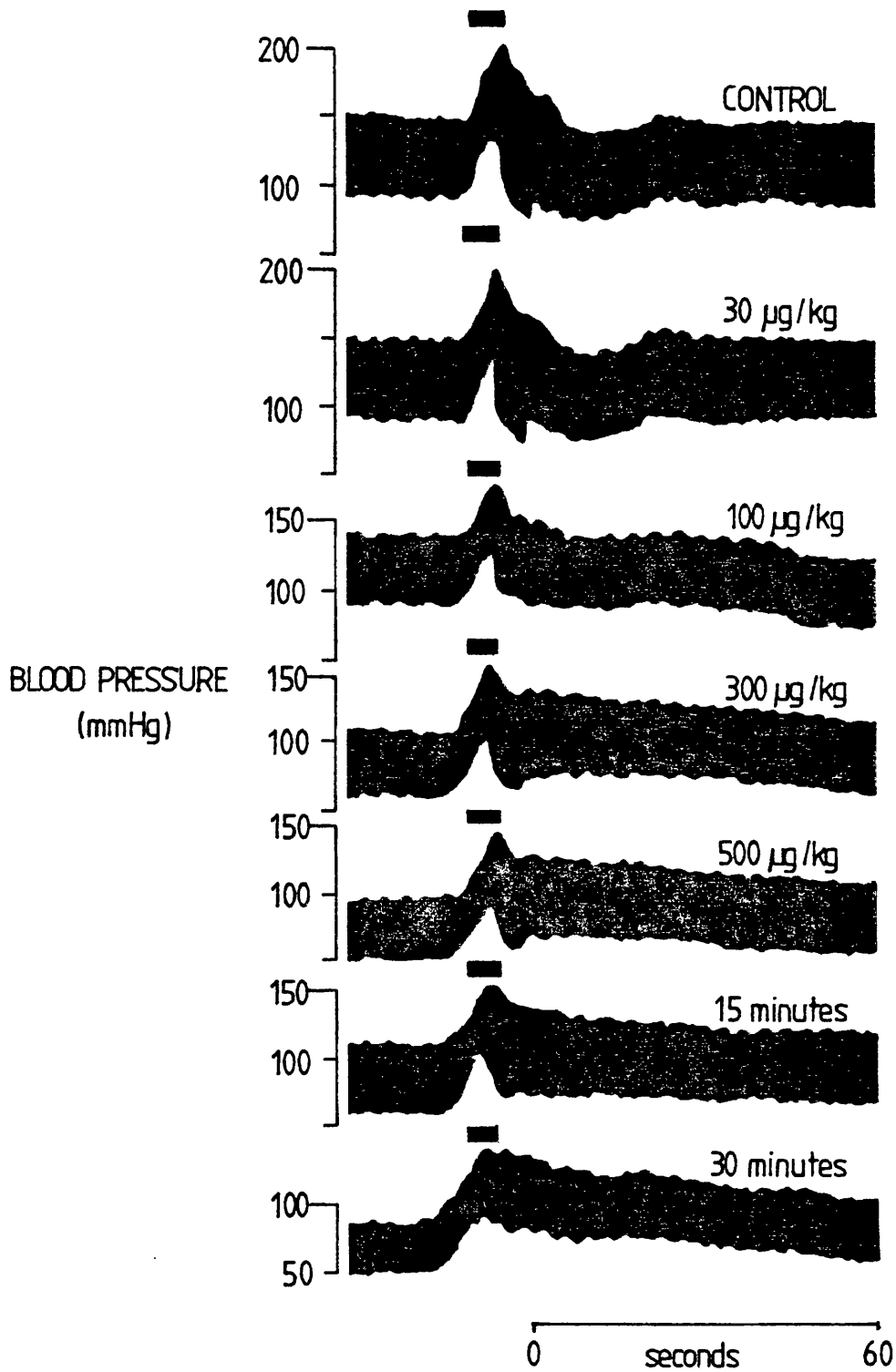

FIGURE 34

Top trace shows effect on blood pressure of electrical stimulation (60 Hz, 2msec pulse width, 200 μ A, 5 second train duration) in the ansa lenticularis of a chloralose anaesthetised cat. Lower traces show the effect of third ventricle infusions of dl-propranolol (30-500 μ g/kg) on the blood pressure response to stimulation. Bottom traces show the response 15 and 30 minutes after the final infusion. Horizontal bars indicate stimulation.

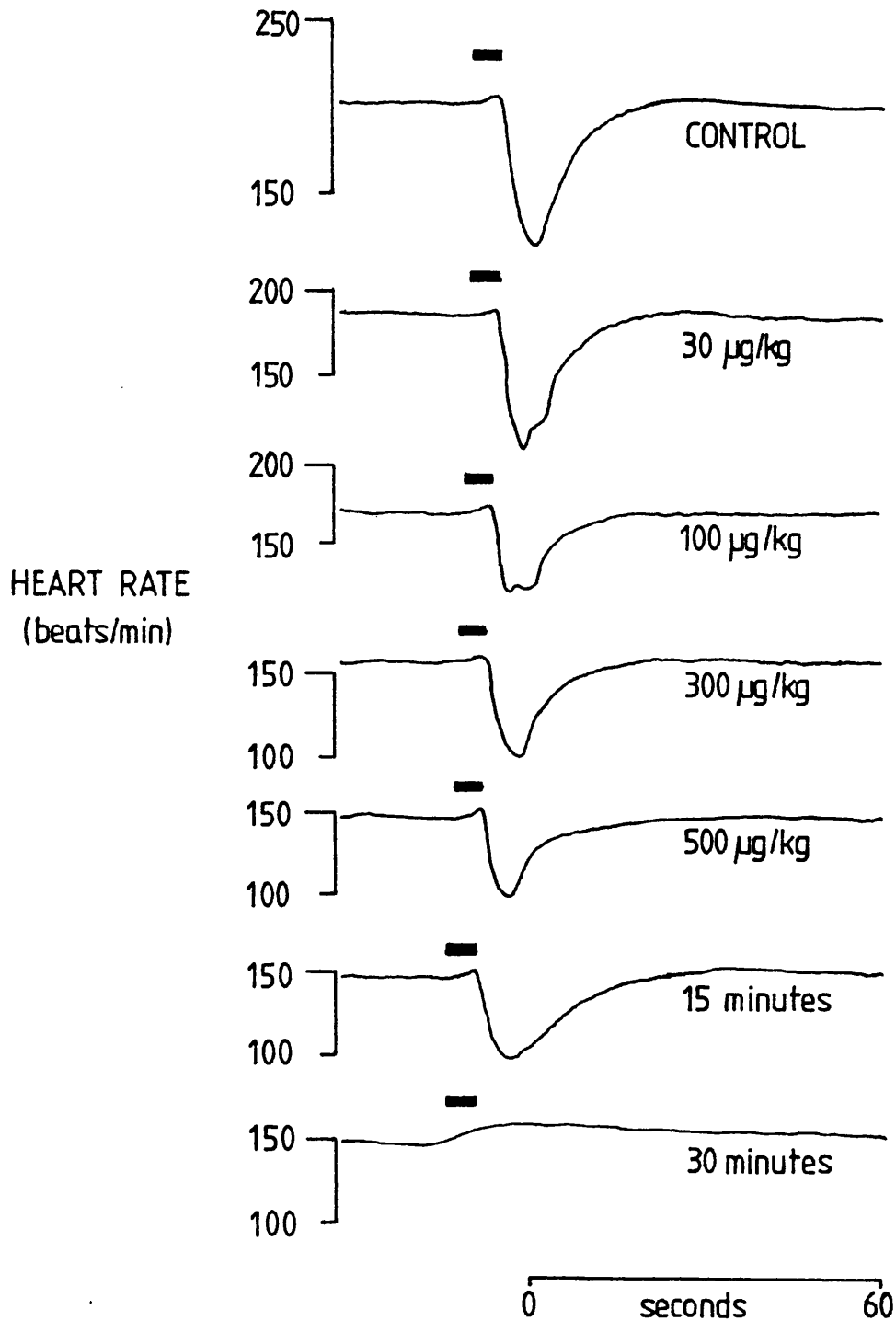

FIGURE 35

Top trace shows effect on heart rate of electrical stimulation (60 Hz, 2 msec pulse width, 200 μ A, 5 second train duration) in the ansa lenticularis of a chloralose anaesthetised cat. Lower traces show the effect of third ventricle infusions of dl-propranolol (30-500 μ g/kg) on the heart rate response to stimulation. Bottom 2 traces show the response 15 and 30 minutes after the final infusion. Horizontal bars indicate stimulation.

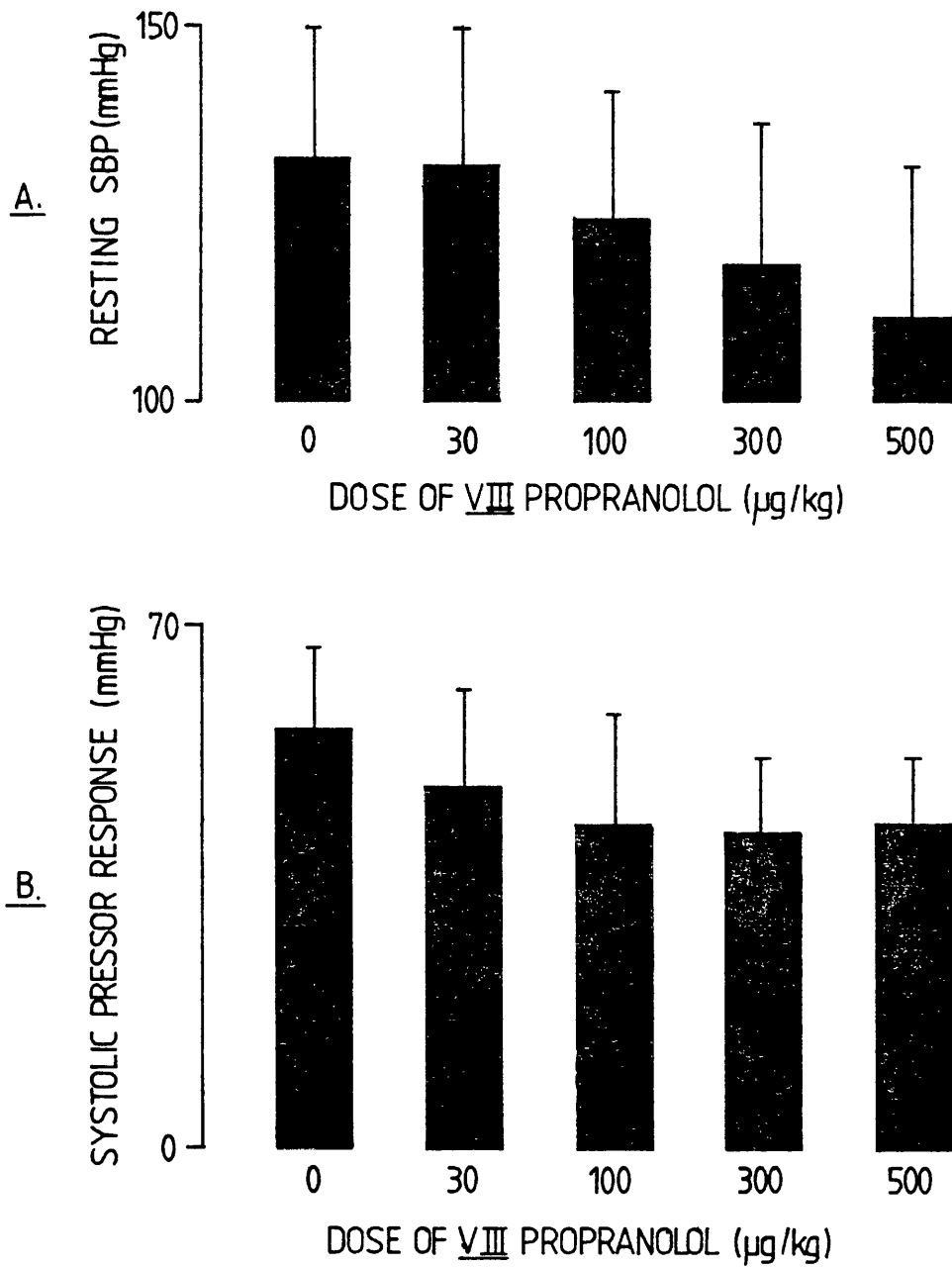

FIGURE 36

- A. Effect of third ventricle (VIII) infusions of dl-propranolol on resting systolic blood pressure (SBP).
 B. Effect of VIII infusions of dl-propranolol on the systolic pressor response to electrical stimulation in the ansa lenticularis.

Each point represents the mean from 3 chloralose anaesthetised cats.

No changes were significant.

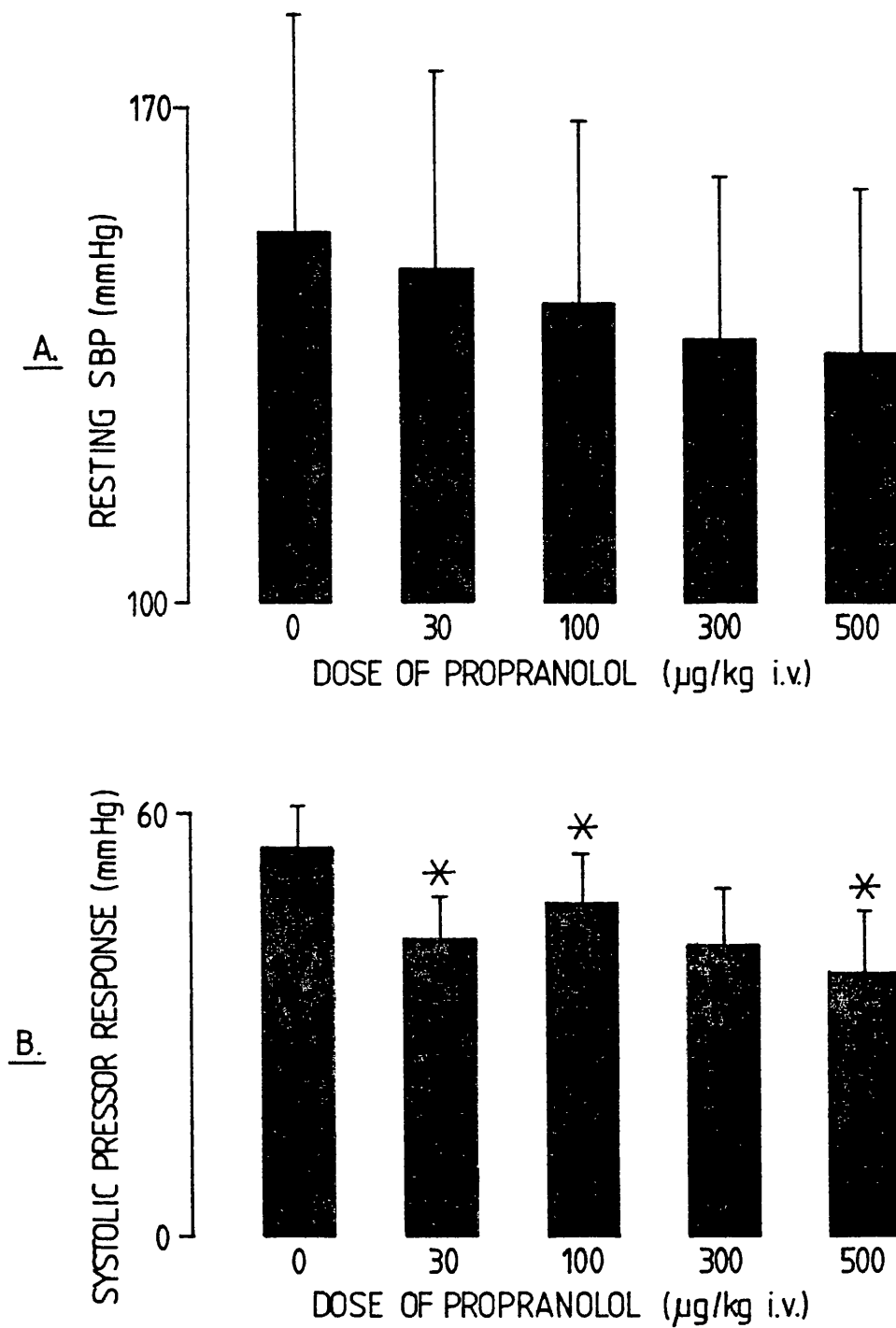

FIGURE 37 A. Effect of intravenous injection of dl-propranolol on resting systolic blood pressure (SBP).
 B. Effect of intravenous dl-propranolol on the systolic pressor responses to electrical stimulation in ansa lenticularis.

Each point represents the mean from 3 chloralose anaesthetised cats. Significant difference from pretreatment control denoted: * $P < 0.05$

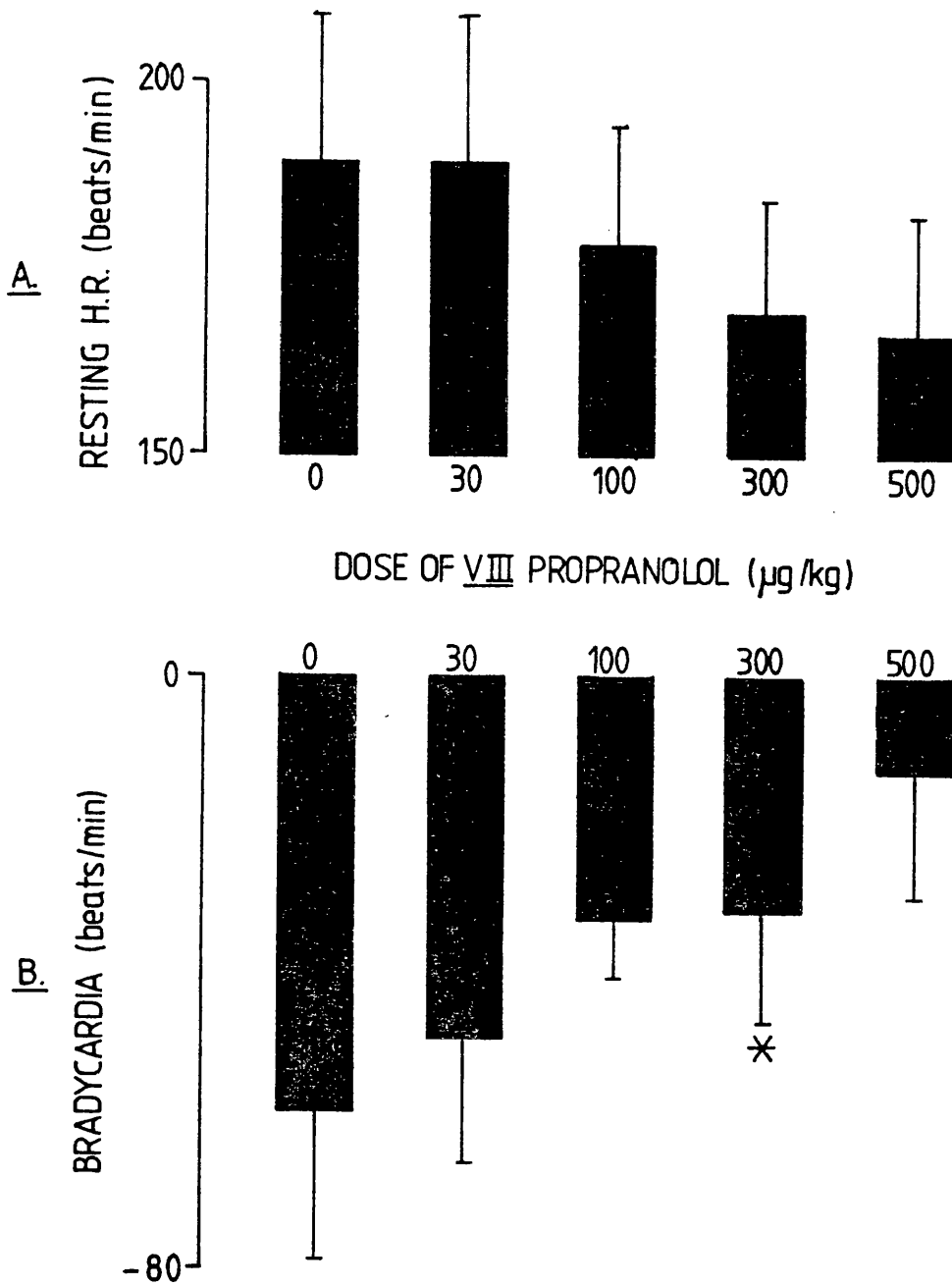

FIGURE 38

- A. Effect of third ventricle (VIII) infusions of dl-propranolol on resting heart rate (HR).
- B. Effect of VIII infusions of dl-propranolol on the bradycardia immediately following electrical stimulation in the ansa lenticularis.

Each point represents the mean from 3 chloralose anaesthetised cats. Significant difference from pretreatment control denoted: * $P < 0.05$

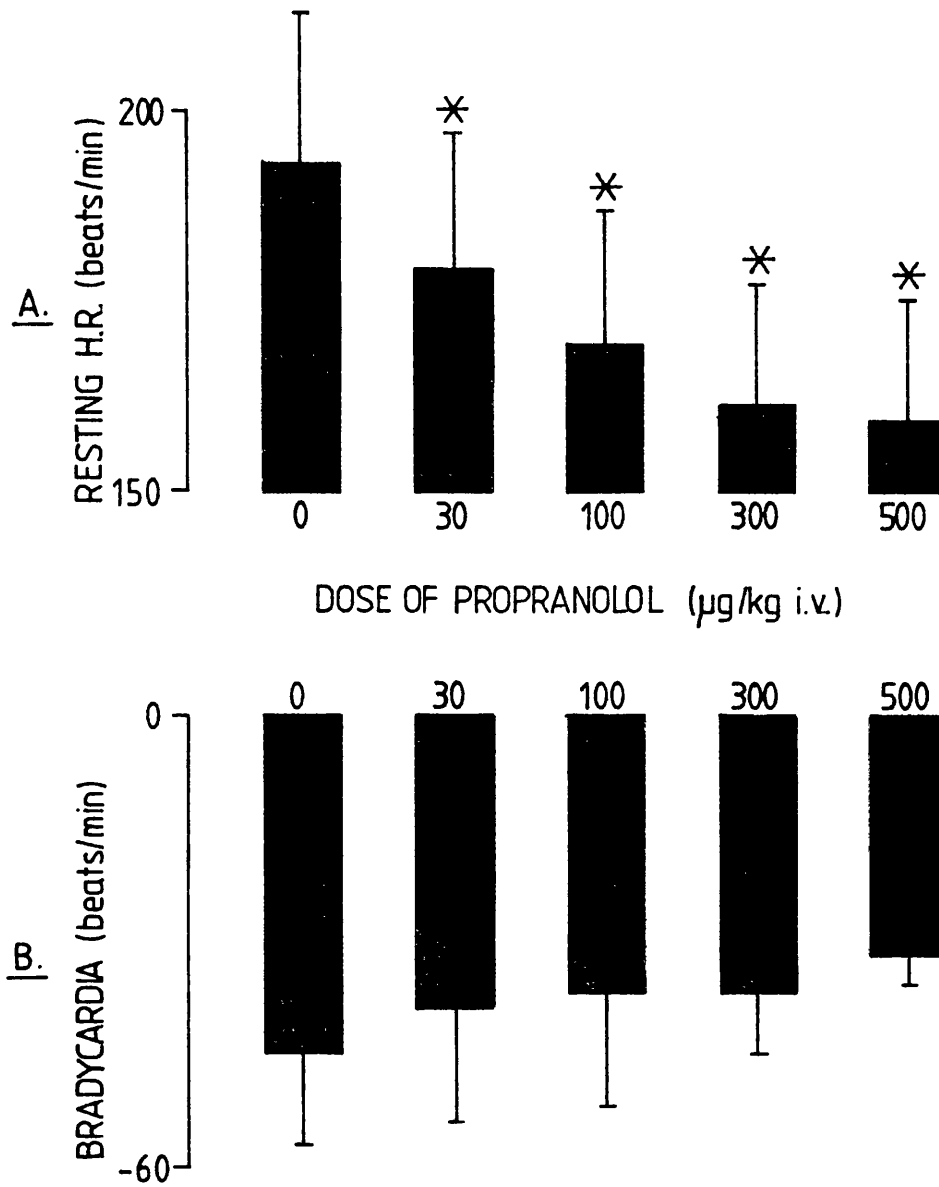

FIGURE 39 A. Effect of intravenous dl-propranolol on resting heart rate (HR).

B. Effect of intravenous dl-propranolol on the bradycardia immediately following electrical stimulation in the ansa lenticularis.

Each point represents the mean from 3 chloralose anaesthetised cats. Significant difference from pretreatment control denoted: * $P < 0.02$

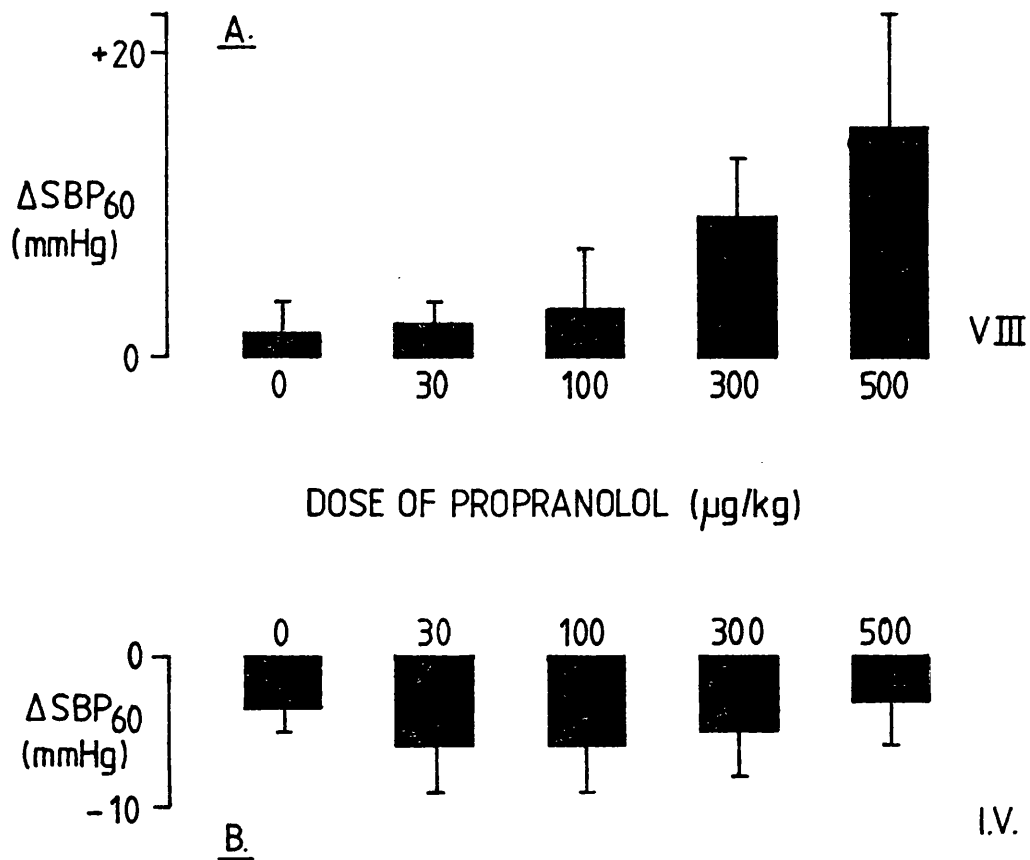

FIGURE 40 Effect of either third ventricle infusion (A) or intravenous injection (B) of dl-propranolol on ΔSBP_{60} following ansa lenticularis stimulation.

ΔSBP_{60} is defined as the difference between systolic blood pressure at 60 seconds following stimulation and the systolic blood pressure immediately before stimulation.

Each point represents the mean from 3 chloralose anaesthetised cats. No statistical differences from pretreatment controls were detected.

(Overpage)

FIGURE 41 Cardiovascular responses to electrical stimulation in the ansa lenticularis.

A. Control

B. One minute after third ventricle infusion of 375 μ g procaine.

Electrical stimulation (60 Hz, 2 msec, 200 μ A, 5 second train duration) indicated by horizontal bar.

Chloralose anaesthetised cat.

B. VIII PROCAINE

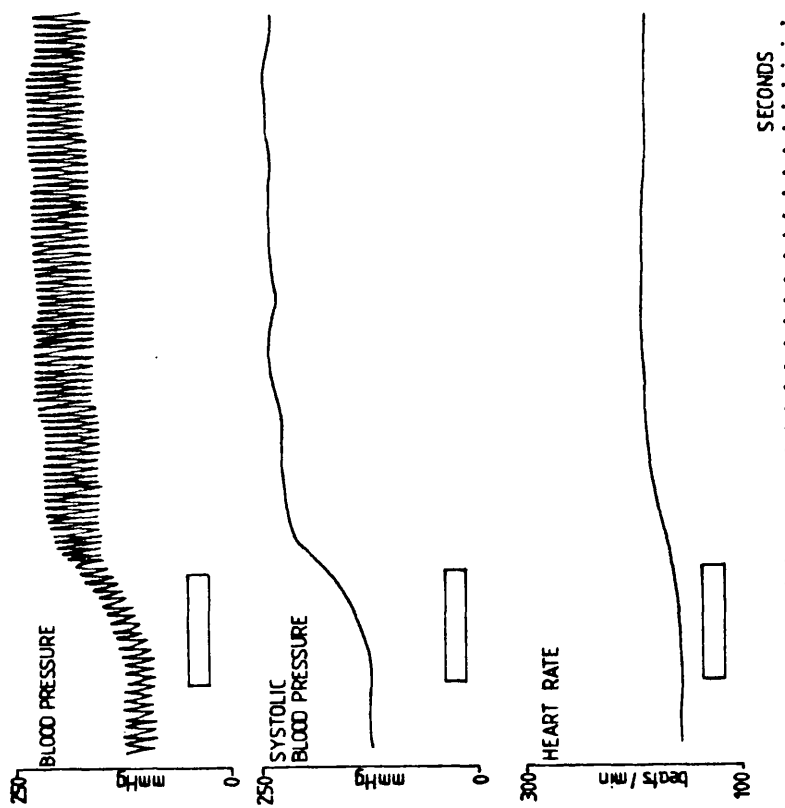

A. CONTROL

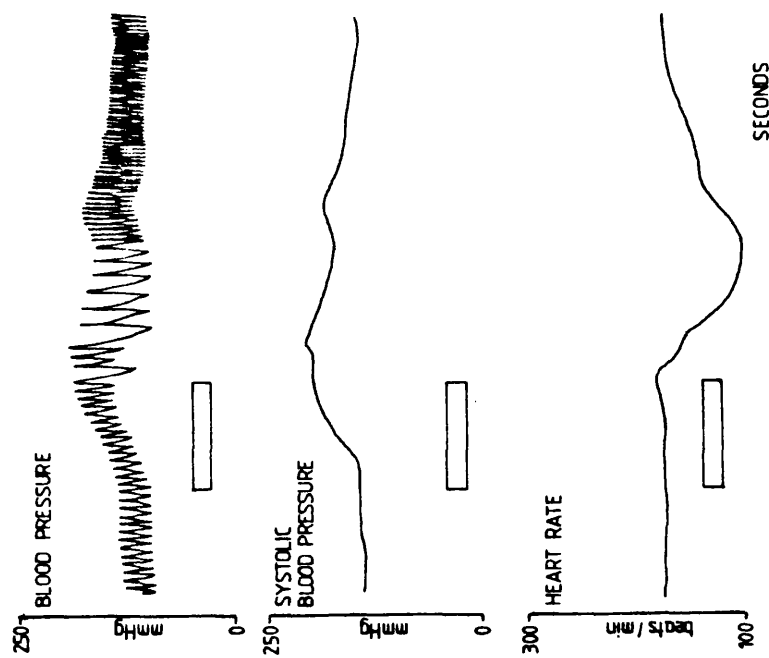

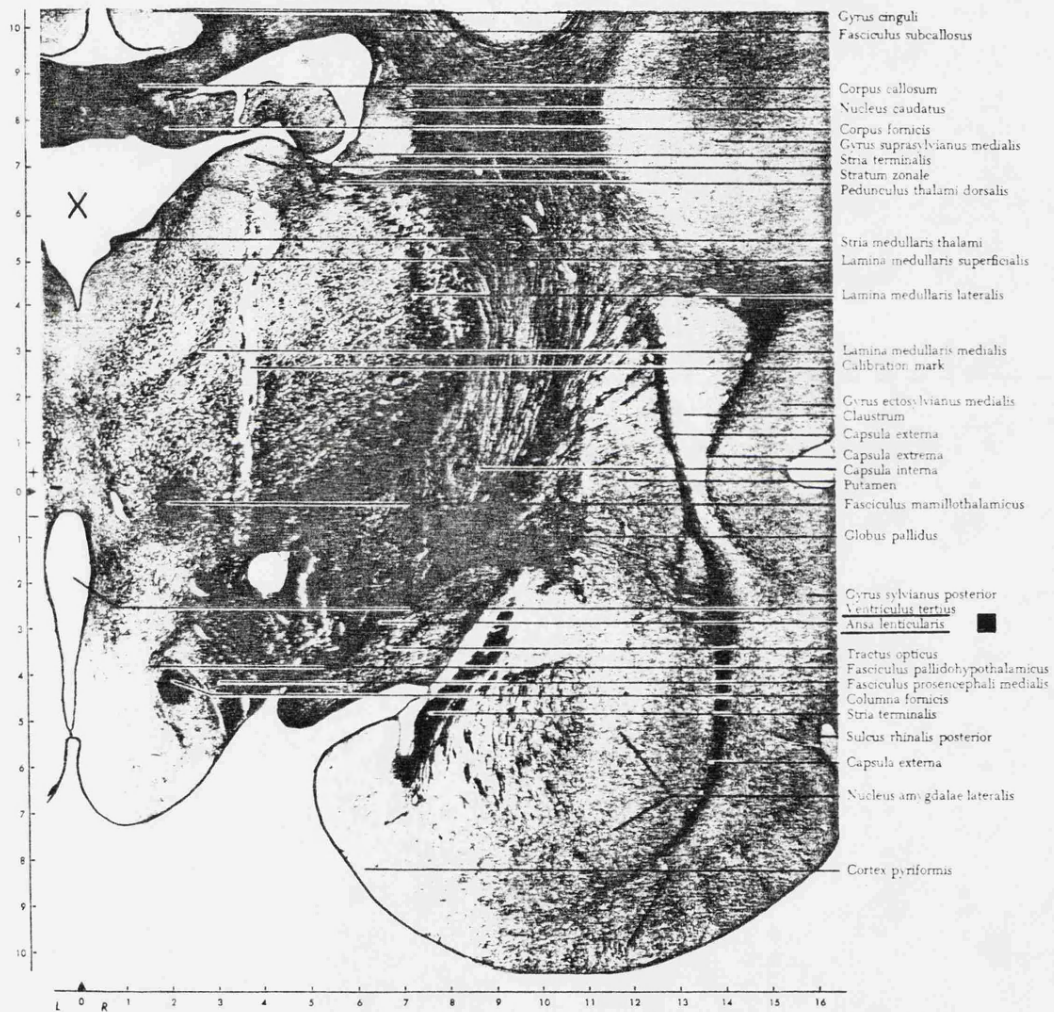

FIGURE 42 Section of cat brain at anterior coordinate (A +10 mm) showing location of the ansa lenticularis and the dorsal (X) and ventral parts of the third ventricle.

(From Snider & Niemer, 1961)

DISCUSSION

Chapter 4

4.1 Resting blood pressure and heart rate of anaesthetised rats

The observation that the blood pressures and heart rates of the halothane anaesthetised rats were considerably lower than those of the thiobutobarbitone anaesthetised animals is in accord with the findings of other workers that halothane induces hypotension (for review see Black, 1971). Although no single factor has been implicated in the production of this hypotension, the following 3 principal mechanisms have been proposed: ganglionic blockade (Raventos, 1956), centrally mediated depression of sympathetic drive (Burn, 1957), and suppression of the peripheral actions of noradrenaline (Price & Price, 1966). The depression of cardiac output with halothane is no greater than that seen with other anaesthetics (Black, 1971), but the cardiovascular consequences of such a depression are more fully expressed since they occur in association with vasodilatation produced in part by the 3 mechanisms outlined above.

4.2 Icv injection of β -blockers

Icv injection of dl-propranolol (100 μ g) produced a significant hypotension in halothane anaesthetised rats (Figure 8) but no change in blood pressure in thiobutobarbitone anaesthetised animals (Figure 9). In fact, in the latter animals lower doses of dl-propranolol (10 and 30 μ g) produced small, but significant, elevations of blood pressure, an effect not seen with 30 μ g d-propranolol (Figure 9). Similarly conflicting results have been obtained by other authors. For example, Wepierre et al (1978) and Cohen et al (1979), using anaesthetised rats, obtained falls in blood pressure after icv injection of 100 μ g

propranolol (dl- and l-forms, respectively), whereas Ito & Schanberg (1974) obtained pressor responses to lower doses of intracisternally injected dl-propranolol (2-40 μ g) in anaesthetised rats. Sweet & Wenger (1976), using unanaesthetised spontaneously hypertensive rats, obtained pressor responses to icv dl-propranolol (10, 50 and 100 μ g) but this was converted to a significant hypotension by 24 hours after the injection.

The observation by Ito & Schanberg (1974) that higher doses of intracisternal dl-propranolol (100-200 μ g) produced depressor responses but that lower doses (2-40 μ g) had a pressor action compares favourably with the present results in thiobutobarbitone anaesthetised animals (Figure 9).

Icv injections of dl-propranolol produced a significant bradycardia in both halothane and thiobutobarbitone anaesthetised rats (Figures 8 and 10). In the latter group of animals the bradycardia was dose-dependent and was not seen with the d-isomer of propranolol (Figure 10). The finding of a bradycardia following central administration of propranolol is common to all the investigations reported above. Thus, regardless of the effects on blood pressure of centrally injected propranolol, a decrease in heart rate is always obtained. The question remains whether the bradycardia is centrally mediated or due to a direct action of the drug on cardiac β -adrenoceptors following leakage from ventricular CSF into the systemic circulation.

The leakage of propranolol from CSF to the bloodstream was investigated in halothane anaesthetised rats by comparing the tachycardic response to intravenous isoprenaline before the icv

injection of dl-propranolol (100 µg) and after the injection, at a time when the bradycardia was fully developed. By this means it was shown that the isoprenaline-induced tachycardia was inhibited by about 85%, and that this level of inhibition was consistent with the leakage of nearly 40 µg of dl-propranolol into the systemic circulation (Section 3.4 and Figure 11). Moreover, intravenous injection of dl-propranolol (50 µg) produced similar falls in blood pressure and heart rate to those produced by icv dl-propranolol (100 µg) in rats anaesthetised with halothane. It would appear, therefore, that the effects on blood pressure and heart rate produced in halothane anaesthetised rats by the icv injection of dl-propranolol may be explained by a solely peripheral action.

That the hypotensive response was only observed in the halothane anaesthetised animals might be explained by the following. The resting blood pressures and heart rates of halothane anaesthetised rats are lower than those of thiobutobarbitone anaesthetised rats (Section 3.2), and the likely reasons for this have been outlined in Section 4.1. Propranolol lowered heart rate in both groups of animals and it is possible that in the thiobutobarbitone anaesthetised rats the fall in heart rate (and probably also cardiac output) produced by leaked propranolol was met by a reflex increase in total peripheral resistance, with the nett result that no change in blood pressure was seen (Cf. in man, Tarazi & Dustan, 1972). In halothane anaesthetised rats, however, restorative reflexes would be impaired (see Section 4.1) and blood pressure may then fall parri passu with cardiac output.

In support of the above theory was the observation in halothane anaesthetised rats that heart rate and blood pressure fell

with similar time courses following icv and intravenous injection of propranolol. Leakage of drugs from the CSF into the systemic circulation is by the process of bulk flow (Rothman et al, 1961; Schanker, 1962) and it seems likely that drugs with low lipid solubility, such as atenolol, will leave the CSF with equal or greater facility than those drugs with high lipid solubility, such as propranolol (see Section 1.5). Since the brain is composed mainly of fatty tissue, highly lipid soluble compounds may be expected to be distributed in the CNS to a greater extent than substances of low lipid solubility following icv injection, with the consequence that more of the low lipid soluble substance will be available to leak out. This lies in contrast to the movement of β -blockers from the circulation into the brain (via the blood-brain barrier), when the greater the lipid solubility of the drug the more readily it enters the brain (Day et al, 1977).

The comparable bradycardic actions of icv atenolol and dl-propranolol in thiobutobarbitone anaesthetised rats (Figure 10) is further cause to suspect a purely systemic action of the drugs since these substances are almost equipotent at in vivo inhibition of isoprenaline-induced tachycardia (Phillips, 1980). Furthermore, that icv atenolol and not the β_2 -selective blocker, ICI 118551, significantly lowered heart rate (Figure 10) might also suggest that the bradycardia is produced by a direct action on the heart following leakage from the CSF. Although a central bradycardic action cannot be excluded, it would seem too coincidental that both central β_1 - and peripheral β_1 -blockade are able to produce bradycardia. Leakage of atenolol from CSF to the circulation was not investigated in the present study.

In none of the investigations cited earlier (Ito & Schanberg, 1974; Sweet & Wenger, 1976; Wepierre et al, 1978; Cohen et al, 1979) was the leakage of centrally injected β -blocker into the systemic circulation investigated by means of determinations of isoprenaline-induced tachycardia before and after injection.

The contention by some authors (for example: Day & Roach, 1974b; Reid et al, 1974) that the membrane stabilising actions of d-propranolol are responsible for an initial pressor response following icv injection of this drug was not borne out in the present investigation.

To the author's knowledge no similar experiments where β -blockers have been centrally injected have been performed in halothane anaesthetised rats.

4.3 Intrahippocampal injection of β -blockers

Following the suggestion by Garvey & Ram (1975a,b) and Ram et al (1977) that the hippocampus is an important central site for the hypotensive action of propranolol, it was decided to investigate the effects of intrahippocampally injected β -blockers on blood pressure and heart rate in halothane anaesthetised rats. The hippocampus is a large structure in the rat having a rostro-caudal extent of some 5 mm and possessing several cytoarchitectonically distinct subdivisions (König & Klippel, 1963). Since there have been no reports in rats where similar experiments have been performed, the choice of the hippocampal subiculum (Figure 3) as the site of drug injection was an empirical one.

Unilateral intrahippocampal injections of l-propranolol (1 and 2 μ g)

produced significant dose-related reductions in blood pressure and heart rate (Figures 12 and 13, respectively). d-Propranolol (2 µg) was ineffective in this respect.

That the hypotension was probably centrally mediated was suggested by the weaker action of intravenous l-propranolol (2 µg) on blood pressure (Figure 14). Furthermore, intravenous l-propranolol (2 µg) had no significant effect on heart rate (Figure 14). However, intrahippocampal injections of atenolol (2 µg) and timolol (2 µg) did not affect blood pressure (Figure 15) or heart rate (Figure 16), even though timolol has been reported to be some four-times more potent than propranolol, at least in respect of its in vivo inhibition of isoprenaline-induced tachycardia (Phillips, 1980).

Intrahippocampal injections of isoprenaline (1 and 2 µg) had no significant effects on blood pressure, although there appeared to be a trend towards a dose-related increase with these doses (Figure 15). Small and non-significant increases in heart rate were produced by these injections except at one sampling point, where isoprenaline (2 µg) evoked a significant tachycardia (Figure 16).

The localisation of the cardiovascular responses to intrahippocampal propranolol was moderately successful (Table 1), significant reductions in blood pressure being obtained after injection in the hippocampus but after injections in the superior colliculus, cortex, or the commissure of the dorsal fornix. However, injections at all sites produced reductions in heart rate but these achieved significance only in the hippocampus and commissure of the dorsal fornix (Table 1).

From the foregoing it would appear that the hypotensive and

and bradycardic effects of intrahippocampal propranolol are unrelated to its β -blocking or membrane stabilising properties, although further work using a larger variety of β -blockers is necessary before any firm conclusions may be drawn.

Although there appeared to be a certain degree of anatomical localisation within the hippocampus of the responses to propranolol, the effects may still have been the result of leakage of the β -blocker into the systemic circulation. The hippocampus is highly vascularised (see Section 1.5) and it is conceivable that the highly lipid soluble propranolol may have reached the periphery by way of hippocampal capillaries. This might explain the lack of effect of atenolol and timolol, two substances having much lower lipid solubility than propranolol (Barrett, 1977 and Tocco et al, 1980, respectively). Although comparison of the cardiovascular responses to intravenously and intrahippocampally injected propranolol suggested that there was an additional central hypotensive action of the drug, leakage of propranolol into the systemic circulation was not excluded by experimentation.

Following injection of propranolol into the carotid artery of the anaesthetised cat, Garvey & Ram (1975b) found the highest post-mortem concentrations of the drug in the hippocampus. On this basis they went on to inject propranolol into the hippocampus of the anaesthetised cat, whereupon they obtained dose-dependent decreases in blood pressure and heart rate. Larger doses injected intra-arterially (carotid) also significantly lowered blood pressure and heart rate but much less effectively. The latter results are therefore consistent with those of the present study.

However, the role of the hippocampus in cardiovascular control is much disputed. For example, in the cat and dog, electrical stimulation of the fimbria, the main efferent tract from the hippocampus, has been recorded to give rise to no detectable autonomic changes (Kaada, 1951). Similarly, Kaada et al (1971) failed to observe any autonomic changes following electrical stimulation of the dorsal or ventral hippocampus in rabbits. In contrast, Cragg (1958), also using rabbits, reported pressor responses upon electrical stimulation in the ventral part of the fimbria, but depressor responses in the dorsal part. In mice with mainly dorsal hippocampal lesions Ely et al (1977) reported the development of high blood pressure, thus implying an inhibitory role of the ablated structure.

Because of the more obvious effects of chemical injection, electrical stimulation and lesioning in brain structures phylogenetically older than the limbic system (for example, brain stem and hypothalamus), it is possible to underestimate the contribution of limbic areas to cardiovascular control. However, the results of the present study, together with those of Garvey & Ram (1975a,b) and Ram et al (1977), suggest that the hippocampus deserves further investigation with respect to the ability of injected β -blockers to modify blood pressure.

4.4 Icv injection of β -blockers and adrenaline

In thiobutobarbitone anaesthetised rats the icv injection of adrenaline produced small and non-significant increases in mean arterial pressure (Figures 17, 19 and 20) and a bradycardia

(Figure 17 and Section 3.10). The finding of a bradycardia is consistent with that of Borkowski & Finch (1977, 1978, 1979), who injected icv adrenaline in anaesthetised and unanaesthetised rats. However, in contrast to the present study, the latter authors reported a hypotension following the central injection of adrenaline, an effect which began about 10 minutes after the injection and was fully developed by about 40 minutes (Borkowski & Finch, 1979). Because of this long time interval before the response was fully expressed it is not clear whether it represents an effect of the adrenaline or, perhaps, an action of a metabolite of the catecholamine. It is difficult to see how a dose of injected adrenaline could retain its chemical integrity for such a long time, especially in the slightly alkaline and warm environment which the CSF provides. (The instability of adrenaline solutions is widely recognised and it is common practice to add small quantities of ascorbate to the solution to delay oxidation of the amine. This protection is all but lost after injection of the adrenaline solution into the CSF). In the present experiments the blood pressure and heart rate were sampled only during the 6 minute period following the start of the adrenaline injection, and no hypotension was apparent during that time.

Following icv pretreatment with dl-propranolol, icv adrenaline injections produced marked increases in blood pressure (Figures 18, 19 and 20), and this effect of propranolol was dose-related within the range 10-100 μ g (Figure 19). The bradycardia caused by the adrenaline injections was unaffected by dl-propranolol pretreatment and, indeed, by all the pretreatments used in the present investigation.

After icv pretreatments with 100 µg each of the β_1 -selective blocker, atenolol, and the β_2 -selective blocker, ICI 118551 (Bilski et al, 1980; O'Donnell & Wanstall, 1980), similar pressor responses to icv adrenaline were obtained (Figure 20).

To investigate the possibility that this unmasking of a pressor response to icv administered adrenaline was centrally mediated, the blood pressure response to icv adrenaline following pretreatment with intravenous atenolol (100 µg) was studied. In this instance, no pressor response to centrally injected adrenaline was observed (Figure 21). Atenolol is a poorly lipid soluble compound which does not readily enter the central nervous system of rats after systemic administration (Day et al, 1977). The lack of a pressor response to icv adrenaline following intravenous atenolol therefore suggests that blockade of central β -adrenoceptors is necessary for the pressor response to adrenaline to be expressed.

At lower icv doses (30 µg) of dl-propranolol, atenolol and ICI 118551, similar pressor responses to icv adrenaline were obtained (Figure 22). However, only dl-propranolol and ICI 118551 produced statistically significant mean arterial pressure changes and, of the two, ICI 118551 appeared to be the most potent (Figure 22 and Section 3.12). The pressor responses to icv adrenaline were subsequently analysed further using a variety of doses of ICI 118551 and adrenaline (Figure 23).

That d-propranolol (30 µg) was ineffective (Figure 22) suggested that the pressor response to icv adrenaline was not dependent on the membrane stabilising properties of either

propranolol (Barrett & Cullum, 1968) or ICI 118551 (Bilski et al, 1980).

Further evidence that central β -adrenoceptor blockade was a requirement for the unmasking of a pressor response to icv adrenaline was provided by the investigations in which both adrenaline and ICI 118551 were injected intravenously (Section 3.13). The increases in blood pressure produced by intravenous injections of adrenaline (0.3 and 1 μ g) were potentiated by intravenous injection of 30 μ g ICI 118551 (Figure 24). This effect was to be expected since blockade of vascular β_2 -adrenoceptors (mediating vasodilatation) would allow the mainly α -adrenoceptor-mediated actions of adrenaline to be expressed (i.e., vasoconstriction). However, it is clear from Figure 24 that the enhancing effect of intravenous ICI 118551 on the pressor response to intravenous adrenaline is of a much smaller magnitude than that produced by icv injections of both these substances.

In rats, Borkowski & Finch (1977, 1978, 1979) obtained an inhibition by icv β -blockers of the hypotension and bradycardia produced by the subsequent icv injection of adrenaline. They therefore concluded that central β -adrenoceptors subserved an inhibitory rôle in central cardiovascular regulation. This conclusion is consistent with that of the present study. The following scheme may be inferred from the present results: icv injected adrenaline exerts effects on blood pressure which are a result of an interaction of the catecholamine with central α - and β -adrenoceptors. Blockade of central β -adrenoceptors would therefore enable the expression of mainly α -adrenoceptor-mediated effects, that is, increases in blood pressure.

Consistent with the above hypothesis was the observation of a dose-related inhibition by icv phentolamine of the pressor response to icv adrenaline following icv pretreatment with ICI 118551 (Figure 25). It appears unlikely that this inhibition by phentolamine was mediated by peripheral α -adrenoceptor blockade (consequent upon leakage of the phentolamine from the ventricular CSF) since the pressor responses to intravenous phenylephrine were only slightly inhibited after the icv injection of 50 μ g phentolamine (Section 3.15 and Figure 26). In contrast, the pressor response to icv adrenaline following pretreatment with icv ICI 118551 was almost abolished by this dose of icv phentolamine (Figure 25).

The observation that the pressor responses to icv injection of either noradrenaline or phenylephrine were unaffected by icv pretreatment with ICI 118551 (Section 3.17 and Figure 28) further supports the above contentions, assuming that noradrenaline and phenylephrine only stimulate α -adrenoceptors in the central nervous system.

In anaesthetised rats Kleinrok & Ksiazek (1977) investigated the effect of icv β -blocker pretreatments on the pressor response to icv noradrenaline (100 μ g). In these experiments the authors obtained an inhibition of the noradrenaline-induced pressor response by icv pretreatment with propranolol (100 μ g), sotalol (100 μ g) and practolol (20 μ g). This inhibition was probably due to an interaction of the drugs within the central nervous system, since it is difficult to see how such results could be obtained by a peripheral action of the drugs following leakage from the CSF (unless the pressor responses were brought about by a direct action of leaked noradrenaline on the heart).

The results of the present study agree with those of Kleinrok & Ksiazek (1977) in so far as both investigations found pressor responses to icv noradrenaline. However, no evidence of an inhibition of the noradrenaline pressor response by icv ICI 118551 was obtained in the present investigation. The apparently greater potency of practolol at inhibiting the noradrenaline-induced pressor responses obtained by Kleinrok & Ksiazek (1977) might suggest that central β_1 -blockade is necessary for expression of the effect. However, this possibility was not investigated in the present report.

If the pressor response to icv adrenaline following central β -blocker pretreatment was of central origin, then one might expect the effect to be mediated by the sympathetic nervous system. However, intravenous hexamethonium only potentiated these responses (Figure 27).

The potentiation of the effects of pressor agents in ganglion-blocked animals is a common finding and is probably due to a combination of the lower initial blood pressure and the compromisation of cardiovascular reflexes which might otherwise tend to limit such excursions of the blood pressure. However, these experiments indicated that the pressor response to icv adrenaline following ICI 118551 pretreatment was likely not to have been effected by way of the sympathetic nervous system.

The possibility existed that the pressor response to icv adrenaline following central β -blockade was mediated by an agent released from the brain into the circulation. Of the possible candidates, vasopressin from the neurohypophysis seemed the most likely, since α -adrenergic mediation and β -adrenergic inhibition

of vasopressin release has been demonstrated in rats (Urano & Kobayashi, 1978). However, intravenous injections of an inhibitor of the pressor actions of vasopressin (Kruszynski et al, 1980) failed to modify the pressor responses to icv adrenaline (Figure 27).

The origin of the pressor response to icv adrenaline following icv pretreatment with β -blockers therefore remains obscure, and the possibility that the effect is mediated, at least in part, by a peripheral action of the drugs cannot be totally excluded.

4.5 Icv β -blockers and electrical stimulation in the rat CNS

Unilateral monopolar electrical stimulation in the anterior hypothalamus, posterior hypothalamus, amygdala and median raphe nucleus of the thiobutobarbitone anaesthetised rat produced frequency-dependent increases in blood pressure (Figures 29A, 30A, 31A and 32, respectively, and Table 2) and variable effects on heart rate.

Pressor responses to electrical stimulation in these areas have been obtained by other authors in a variety of species - anterior hypothalamus (Cragg, 1958; Evans & Williamson, 1981), posterior hypothalamus (Karplus & Kreidl, 1909; Folkow & Rubinstein, 1966), amygdala (Torii & Kawamura, 1960; Heinemann et al, 1973), median raphe nucleus (Smits et al, 1978; Kuhn et al, 1980).

The pressor responses to electrical stimulation in the posterior hypothalamus (Figure 30B), amygdala (Figure 31B) and median raphe nucleus (Figure 33A) were unaffected by icv injection of dl-propranolol (100, 50 and 50 μ g, respectively). In the anterior

hypothalamus pressor responses to electrical stimulation were enhanced by icv dl-propranolol (50 μ g), but only at the lowest frequency of stimulation did this achieve statistical significance (Figure 29B). Icv atenolol (50 μ g) potentiated the pressor responses to electrical stimulation in the median raphe nucleus but this was significant only at the highest frequency of stimulation (Figure 33B).

It is possible that the weak and inconsistent effects produced by central β -blocker injection on the responses to electrical stimulation in these 4 brain regions reflect the minor rôle of brain β -adrenoceptors in the mediation of the responses, assuming, of course, that β -adrenoceptors do in fact lie in the pressor effector pathways from these brain sites. On the other hand, the possibility that β -blockers injected icv do not reach a potential site of action cannot be excluded.

It is difficult to discuss these results in the light of other people's findings since, to the author's knowledge, no similar experiments have hitherto been performed.

In anaesthetised rats Allott et al (1982) investigated the effects of propranolol and atenolol on the pressor responses evoked by electrical stimulation (through the tip of an injection cannula) in an area immediately above the posterior hypothalamus. The β -blockers were injected through the cannula into the area of stimulation. The pressor responses were inhibited by l-, dl- and d-propranolol but not by the β_1 -selective blocker, atenolol. The l-isomer of propranolol was some 4-times more potent than the d-isomer. Thus, both β_2 -blockade and membrane stabilising

activity may account for the suppression of the pressor responses, since d-propranolol has about 1/100th the β -blocking potency of the l-isomer (Barrett & Cullum, 1968).

The above type of experiment using focal stimulation and injection is probably more sensitive than the type used in the current study, although the present study does allow for a potential interaction of the β -blocker at various loci along the pressor effector pathway originating from the stimulated region, assuming that such a pathway is a multi-synaptic one. Moreover, the present design may have greater utility in the screening of potential centrally-acting antihypertensives since, in the therapeutic sense, the drug will have access to most of the brain (assuming that it can enter the central nervous system in the first instance).

Philippu & Kittel (1977) and Philippu & Stroehl (1978) used a similar technique to that used by Allott et al (1982) but in the anaesthetised cat. In this way they demonstrated the inhibition of the pressor responses to electrical stimulation in the posterior hypothalamus by atenolol, practolol, metoprolol, propranolol, sotalol and butoxamine. Membrane stabilising activity was not important in this inhibition since d-propranolol and procaine were ineffective in this respect.

The dependence of the response evoked by electrical stimulation in the median raphe nucleus on brain 5-hydroxytryptamine has been previously demonstrated (Smits et al, 1978), and the present findings may lend further weight to the evidence against an in vivo interaction of β -blockers with the 5-HT receptor (see for example, Blackburn & Heapy, 1982).

4.6 Icv β -blockers and electrical stimulation in the cat CNS

It has been known for some time that electrical stimulation in certain areas of the posterior hypothalamus of unanaesthetised cats leads to a behavioural response which has been termed the defence reaction (Hess & Brügger, 1943). Abrahams et al (1960) showed that electrical stimulation of these areas in anaesthetised cats led to a pattern of autonomic changes which included vasodilatation in skeletal muscle (mediated by cholinergic sympathetic fibres), elevations of blood pressure, tachycardia, pupillary dilatation and retraction of the nictitating membrane. Hilton & Zbrozyna (1963) later showed that the defence reaction (including all its autonomic and somatic events) could be elicited by electrical stimulation in "any part of the connecting band, which extends as a thin sheet between the amygdala and the whole length of the hypothalamus". Although not referred to in the report by its anatomical name, the points in the connecting band from where stimulation produced the defence reaction undoubtedly lie along the ansa lenticularis. All the above mentioned autonomic events have subsequently been observed by P.W.Marshall (personal communication) following stimulation in the ansa lenticularis in althesin anaesthetised cats.

In the chloralose anaesthetised cats used in the present study, stimulation in the ansa lenticularis led to an increase in blood pressure (Figure 34) and a small tachycardia (Figure 35). When stimulation was stopped there was an abrupt bradycardia (Figure 35) and a gradual return of blood pressure to pre-stimulation levels (Figure 34). The combined changes in blood pressure and heart rate are best demonstrated in Figure 41A. Pupillary dilatation and

retraction of the nictitating membrane accompanied these stimulations.

Third ventricle infusions of dl-propranolol produced small but non-significant reductions in the pressor response to ansa.....pto

lenticularis stimulation (Figure 36B), whereas intravenous dl-propranolol significantly reduced these responses (Figure 37B). In contrast, third ventricle infusions of dl-propranolol attenuated the 'off-bradycardia' associated with cessation of stimulation (Figure 38B), an effect which was not seen with intravenous dl-propranolol (Figure 39B).

The return of blood pressure to pre-stimulation levels was not affected by intravenous dl-propranolol but was markedly delayed after third ventricle infusions of the β -blocker (Figure 40 and Section 3.21). This effect is also shown in the traces from one animal in Figure 34. The 'off-bradycardia' was also diminished by third ventricle dl-propranolol infusions and at one point was abolished (Figure 35). Intravenous dl-propranolol did not affect the magnitude of the 'off-bradycardia' as markedly as did third ventricle infusions of the drug (Figure 39B).

In one animal the effect of third ventricle infusion of procaine on the cardiovascular changes associated with ansa lenticularis stimulation was examined. In this instance, both blood pressure and heart rate remained elevated following cessation of stimulation (Figure 41 and Section 3.21).

It would therefore appear from the foregoing that the differential effects of centrally and systemically administered dl-propranolol on the cardiovascular changes accompanying stimulation in the ansa lenticularis may be explained solely by the membrane stabilising properties of the drug. Confirmation of this would require third ventricle infusions of d-propranolol, although this was not attempted in the present study.

The effects of lateral ventricle infusions of procaine in chloralose anaesthetised dogs have been described by Haranath et al. (1965). These authors found that procaine induced a rise in blood pressure of about 70 mmHg. That the response took about 3 minutes to begin suggests that the site of action of the local anaesthetic was some distance away from the injection site.

The results from the present study may indicate an action of third ventricle infusions of dl-propranolol and procaine on a central component of the baroreflex arc for the following reasons. During stimulation there appears to be an inhibition of the baroreceptor reflex since heart rate does not reflexly fall during stimulation. However, immediately after stimulation heart rate drops profoundly, presumably as a result of the raised blood pressure. The qualitative similarity between the effects of the dl-propranolol and procaine may imply a similar site of action.

Both central and systemic injections of dl-propranolol reduced resting blood pressure and heart rate in these animals (Figures 36A, 37A, 38A and 39A).

The results discussed in this section were derived from a total of 7 animals and the conclusions to be drawn from such a low number of experiments are necessarily few. Even so, every effort was made to ensure that the animals remained in a good physiological condition throughout the experiment (with particular attention to acid-base balance).

4.7 General conclusions

In none of the experiments performed during the course of this

study was the view upheld that central β -blockade can lower blood pressure and heart rate. In fact, the converse appeared to be true, at least in the experiments where β -blockade unmasked a pressor response to centrally injected adrenaline.

It is apparent from electrophysiological studies that central α - and β -adrenoceptors differ from their peripheral counterparts in a number of respects. For example, in the central nervous system isoprenaline can stimulate both α - and β -adrenoceptors (Szabadi, 1979) and that central β -adrenoceptors are capable of being stimulated by both noradrenaline and adrenaline (see Section 1.7). Furthermore, central α -adrenoceptors are stimulated by noradrenaline (Szabadi, 1979) and probably also adrenaline. In some areas of the central nervous system neuronal responses to noradrenaline and isoprenaline can be blocked by both α - and β -adrenoceptor blocking agents (Szabadi, 1979). Thus, the effects of conventional α - and β -blocking compounds injected into the central nervous system should be considered with caution, and care taken not to assume that central administration of say, a β -blocking drug, will lead solely to blockade of β -adrenoceptors.

Possible future lines of research in this field will now be considered. Lebel & Weeks (1982) demonstrated the potentiation of the carotid occlusion pressor response by central α_2 -adrenoceptor blockade in dogs. Similar experiments with β -adrenoceptor blocking agents may yield useful information as to their possible central actions on the cardiovascular system. More extensive work similar to that of Allott et al (1982 - see Section 4.5) may give valuable information concerning the effects of β -blocking drugs on electrically evoked pressor and depressor responses in various brain areas.

In cats, Brazenor & Bentley (1981) investigated the effects of centrally administered α -adrenoceptor agonists on the pressor responses reflexly produced by stimulation of the cut central ends of the brachial nerves. Adrenaline and phenylephrine reduced the size of the pressor responses. Centrally injected β -blockers may also influence this response.

Clearly, there is much scope for future investigation and there remains good reason to believe that brain β -adrenoceptors may play a rôle, albeit minor compared to central α -adrenoceptors, in the central regulation of the cardiovascular system.

4.8 Addendum: Conscious v. anaesthetised preparations

Throughout the present study only anaesthetised preparations were used, although an aborted attempt was made to investigate the effects of intrahippocampally injected propranolol in two unanaesthetised dogs equipped with chronic indwelling intracranial cannulae. However, in both animals, as soon as the injections were begun the animals became restless and even diverted their gaze upwards as if aware that the injection was being made. In consequence, the blood pressure traces contained too much noise (produced by movement of the animal) and the attempt was abandoned. It is arguable that the animals could have been trained to accept the injections but this was not possible given the relatively short time available. Nevertheless, the physical presence of the injectate in the brain of the animal and/or a pharmacological action of the β -blocker were having noticeable effects on the animal's behaviour.

The use of conscious animals in experiments where drugs are injected centrally has already been preliminarily discussed in the Introduction (Section 1.5), where it was mentioned that some substances may produce changes in the state of arousal of the animal.

An example of a centrally acting hypotensive drug which can produce sedation after central injection is clonidine. In rats, Drew et al (1979) demonstrated the sedative effects of clonidine following both icv and parenteral injections in rats. The latter group also demonstrated sedative actions of xylazine, naphazoline and methoxamine following similar injections. In their introduction to the report the authors state: "It was further considered that the sedation could be secondary to a hypothermic action of the drugs and so their effects on core temperature were also recorded. In case the sedation was secondary to a fall in blood pressure the effects of hydrallazine, a potent, peripherally-acting hypotensive agent, were also determined in both sedation tests" (Drew et al 1979). In the event, neither of these effects was shown to influence the sedation, although the caution expressed by the authors illustrates the kind of problems associated with multiple actions of drugs.

At the other end of the arousal spectrum piperoxan, a drug which can reduce the sedative and blood pressure lowering actions of clonidine (Schmitt et al, 1971; Delbarre & Schmitt, 1973), also produced significant increases in wakefulness in rats (Fuxe et al, 1974).

In the case of clonidine the sedative and hypotensive effects

appear to be mediated by pharmacologically distinct populations of receptors (Drew et al, 1979; Clough & Hatton, 1981).

Nevertheless, a dose of clonidine injected centrally will be expected to interact with both of these populations.

In man, sleep is associated with a lower blood pressure than that seen during waking (Floras et al, 1978; Mann et al, 1979), the sleep blood pressure being about 20 mmHg lower. It seems likely that the reduced blood pressure seen during sleep is part of the generalised switching-off of brain stem activating mechanisms and that neither precedes the other in cause-and-effect terms.

Thus, problems may arise in experiments in unanaesthetised animals if a centrally administered compound has effects on arousal and/or cardiovascular mechanisms in the brain. A drug having an action predominantly on arousal may have secondary effects on blood pressure which might be misconstrued as a primary action on central cardiovascular regulation.

To illustrate the problem further the following analogy is proposed. Suppose a new drug, X, is given to 2 investigators to analyse its biological actions. Investigator 'A' is interested in the neuropharmacology of arousal whereas investigator 'B' is interested in the pharmacology of the central regulation of blood pressure. Both use 'conscious' preparations. Subsequently, 'A' will report the actions of the centrally injected drug on arousal and 'B' will report its effects on blood pressure. It is unlikely that 'B' will mention any changes in the arousal state of the animal and it is almost certain that 'A' will not

have even measured blood pressure. If we are now told that the 'new' drug was in fact pentobarbitone the problem becomes clear: how we view a drug's actions depends on the investigator's viewpoint. Thus, any change in blood pressure seen after icv pentobarbitone may have been the result of incipient general anaesthesia.

Although general anaesthesia may alleviate the difficulties associated with alterations in arousal consequent upon central injection of drugs, it introduces a new set of problems. The following is taken from the review of Calaresu et al (1975): "Anaesthetics are commonly used in experimental studies, although it is frequently assumed that data obtained from awake animals are a better indication of the normal operation of the central regulation of the cardiovascular system. It has been suggested that experiments in anaesthetised animals are 'probably distorted by absence or distortion of nervous compensating mechanisms presumably active in conscious animals' (Uvnäs, 1960). There is also a different sensitivity of different parts of the neuraxis to anaesthetic agents which complicates the interpretation of experimental results. The most widely recognized differential effect of anaesthetics is their greater suppression of cortical and diencephalic function than of medullary function; this could result in a systematic bias towards assigning to the medulla an exaggerated role in the regulation of the cardiovascular system."

The effects of different general anaesthetics on the electrophysiology of central neurones has been reviewed by Szabasi (1979). For example, chloralose markedly reduces the sensitivity of cortical neurones to acetylcholine and excitant

amino acids, whereas urethane, nitrous oxide, trichloroethylene and halothane have little effect. Also, excitatory responses to noradrenaline in the cortex are rarely observed in preparations anaesthetised with barbiturates and urethane, but are commonly seen in preparations anaesthetised with halothane (Szabadi, 1979).

A study of the cardiorespiratory changes during electrical stimulation of the septum in the rat under chloralose or urethane anaesthesia revealed that blood pressure was changed in opposite directions under the 2 anaesthetics (Calaresu & Mogenson, 1972).

Day et al (1980) obtained greater pressor responses to third ventricle infusions of noradrenaline in unanaesthetised cats than in chloralose anaesthetised animals.

Although Haranath et al (1965) obtained pressor responses to icv injections of procaine in unanaesthetised and chloralose anaesthetised dogs, only a gradual fall in blood pressure was seen in pentobarbitone anaesthetised animals.

There is no ideal anaesthetic but perhaps one of the better ones is althesin ('Saffan', Glaxo). This drug is infused continuously into a peripheral vein and depth of anaesthesia can be regulated moment-to-moment by varying the rate of infusion. In this way it is possible to maintain the lightest level of anaesthesia consistent with unconsciousness and the requirements of law. Such fine control of depth of anaesthesia is impossible with chloralose, pentobarbitone and thiobutobarbitone, for example.

The value of the anaesthetised preparation rests in the ability of the investigator to measure many variables under

carefully controlled experimental conditions that are not often possible in the unanaesthetised animal. Blood pressure and heart rate are at their most stable under anaesthesia and this allows the measurement of small changes in both parameters which might otherwise be obscured by noise caused by, say, movement of the animal.

The question remains whether a change that is observed under anaesthesia will also be observed in the unanaesthetised preparation.

REFERENCES

- ABRAHAMS, VC, HILTON, S.M. & ZBROZYNA, A. (1960)
Active muscle vasodilatation produced by stimulation of the brain stem: its significance in the defence reaction.
J. PHYSIOL. 154, 491-513
- ADLER-GRASCHINSKY, E. & LANGER, S.Z. (1975)
Possible role of a β -adrenoceptor in the regulation of noradrenaline release by nerve stimulation through a positive feedback mechanism.
BR. J. PHARMAC. 53, 43-50
- ALLOTT, C.P., GREENWOOD, D.T. & MARSHALL, P.W. (1982)
The involvement of central β -adrenoceptors in blood pressure control in the rat.
BR. J. PHARMAC. 75, (Suppl.), 69P
- AMER, M.S. (1975)
Cyclic nucleotides in disease: on the biochemical etiology of hypertension.
LIFE SCI. 17, 1021-1038
- AMER, M.S. (1977)
Mechanism of action of β -blockers in hypertension.
BIOCHEM. PHARMAC. 26, 171-175
- AMER, M.S., DOBA, N. & REIS, D.J. (1975)
Changes in cyclic nucleotide metabolism in aorta and heart of neurogenically hypertensive rats: possible trigger mechanism of hypertension.
PROC. NAT. ACAD. SCI. (USA) 72, 2135-2139
- AMERY, A., FAGARD, R., DePLAEN, J.F., LIJNEN, P. & REYBROUCK, T. (1976)
The relationship between beta-blockade, hyporeninaemic and hypotensive effect of two beta-blocking agents.
POSTGRAD. MED. J. 52, (Suppl. 4), 102-108
- ANDERSON, W.P., KORNER, P.I., BOBIK, A. & CHALMERS, J.P. (1977)
Leakage of dl-propranolol from cerebrospinal fluid to bloodstream in the rabbit.
J. PHARMACOL. EXP. THER. 202, 320-325

ANTONACCIO, M.J. (1977)

Neuropharmacology of central mechanisms governing the circulation.
In: Cardiovascular Pharmacology. Ed: M. Antonaccio. Pp. 131-165.
Raven Press, New York.

AOI, W., HENRY, D.P. & WEINBERGER, M.H. (1976)

Evidence for a physiological role of renal sympathetic nerves in
adrenergic stimulation of renin release in the rat.
CIRC.RES. 38, 123-129

BARRETT, A.M. (1977)

The pharmacology of atenolol.
POSTGRAD.MED.J. 53, (Suppl.3), 58-64

BARRETT, A.M. & CULLUM, V.A. (1968)

The biological properties of the optical isomers of propranolol and
their effects on cardiac arrhythmias.
BR.J.PHARMAC. 34, 43-55

BHARGAVA, K.P., MISHRA, N. & TANGRI, K.K. (1972)

An analysis of central adrenoceptors for control of cardiovascular
function.
BR.J.PHARMAC. 45, 596-602

BIANCHETTI, G., ELGHOZI, J.L., GOMENI, R., MEYER, P. & MORSELLI, P.L. (1980)

Kinetics of distribution of dl-propranolol in various organs and
discrete brain areas of the rat.
J.PHARMACOL.EXP.THER. 214, 682-687

BILSKI, A., DORRIES, S., FITZGERALD, J.D., JESSUP, R., TUCKER, H. &
WALE, J. (1980)

ICI 118551, a potent β_2 -adrenoceptor antagonist.
BR.J.PHARMAC. 69, 292P-293P

BLACK, G.W. (1971)

Circulatory, respiratory and metabolic effects of inhalational
anaesthetics. In: General Anaesthesia, Vol.1 Eds: T.C.Gray and
J.F.Nunn. Pp: 465-482. Butterworth, London.

- BLACK, J.W., DUNCAN, W.A.M. & SHANKS, R.G. (1965)
Comparison of some properties of pronethalol and propranolol.
BR.J.PHARMAC. 25, 577-591
- BLACK, J.W. & STEPHENSON, J.S. (1962)
Pharmacology of a new adrenergic beta-receptor blocking compound
(nethalide).
LANCET II, 311-314
- BLACKBURN, T.P. & HEAPY, C.G. (1982)
(-)-propranolol is not an antagonist of 5-HT in vivo.
BR.J.PHARMAC. 75, (Suppl.), 99P
- BOGAERT, A. van & SCHEPPER, J. de (1979)
Influence of some hypotensive drugs on the effects of hypothalamic
stimulation.
CARDIOLOGY 64, 162-169
- BOISSIER, J.R., GIUDICELLI, J.F., FICHELLE, J., SCHMITT, H. &
SCHMITT, H. (1968)
Cardiovascular effects of 2-(2,6-dichlorophenylamino)-2-imidazoline-
hydrochloride (St 155). I. Peripheral sympathetic system.
EUR.J.PHARMACOL. 2, 333-339
- BORKOWSKI, K.R. & CLOUGH, D.P. (1981)
Adrenaline-induced cardiovascular depressor effects in conscious dogs.
BR.J.PHARMAC. 72, 52OP
- BORKOWSKI, K.R. & FINCH, L. (1977)
Cardiovascular responses to centrally administered adrenaline in
spontaneous hypertensive rats.
BR.J.PHARMAC. 61, 13OP
- BORKOWSKI, K.R. & FINCH, L. (1978)
Cardiovascular responses to intraventricular adrenaline in
spontaneous hypertensive rats.
EUR.J.PHARMACOL. 47, 281-290

BORKOWSKI, K.R. & FINCH, L. (1979)

A comparison of the cardiovascular effects of centrally administered clonidine and adrenaline in the anaesthetised rat.

J.PHARM.PHARMACOL. 31,16-19

BRADBURY, M. (1979)

The Concept of a Blood-Brain Barrier. Wiley, New York.

BRADLEY, P.B. & GLADMAN, J.R.F. (1981)

Microiontophoretic study of the interaction between β -adrenoceptor antagonists and 5-hydroxytryptamine in the rat brain stem.

BR.J.PHARMAC. 73,245P

BRAZENOR, R.M. & BENTLEY, G.A. (1981)

Central effects of α -adrenoceptor agonist drugs on a cardiovascular reflex evoked by stimulation of somatic afferents.

EUR.J.PHARMACOL. 73,213-215

BURN, J.H., EPSTEIN, H.G., FEIGAN, G.A. & PATON, W.D.M. (1957)

Some pharmacological actions of Fluothane.

BR.MED.J. 2,479-483

BYLUND, D.B. & SNYDER, S.H. (1976)

Beta adrenergic receptor binding in membrane preparations from mammalian brain.

MOL.PHARMACOL. 12,568-580

CALARESU, F.R., FAIERS, A.A., & MOGENSEN, G.J. (1975)

Central neural regulation of heart and blood vessels in mammals.

PROG.NEUROBIOL. 5,3-35

CALARESU, F.R. & MOGENSEN, G.J. (1972)

Cardiovascular responses to electrical stimulation of the septum in the rat.

AMER.J.PHYSIOL. 223,777-782

CHASIN, M., RIVKIN, I., MAMRAK, F., SAMANIEGO, S.G. & HESS, S.M. (1971)

α - and β -adrenergic receptors as mediators of accumulation of cyclic adenosine 3',5'-monophosphate in specific areas of guinea pig brain.

J.BIOL.CHEM. 246,3037-3041

- CLOUGH, D.P. & HATTON, R. (1981)
Hypotensive and sedative effects of α -adrenoceptor agonists:
relationship to α_1 - and α_2 -adrenoceptor potency. 150
BR.J.PHARMAC. 73, 595-604
- COHEN, M.L. & BERKOWITZ, B.A. (1976)
Decreased vascular relaxation in hypertension.
J.PHARMAC.EXP.THER. 196, 396-406
- COHEN, Y., LINDENBAUM, A., MIDOL-MONNET, M., PORQUET, D. &
WEPIERRE, J. (1979)
 β -adrenoceptor blocking drugs and isoprenaline: central effects
on cardiovascular parameters.
BR.J.PHARMAC. 65, 389-394
- CONWAY, E.L. & LANG, W.J. (1974)
Cardiovascular responses produced by the injection of isoprenaline
into the cerebral ventricles of the unanaesthetised dog.
CLIN.EXP.PHARMACOL.PHYSIOL. 1, 59-64
- COX, B., LEE, T.F. & MARTIN, D. (1981)
Different hypothalamic receptors mediate 5-hydroxytryptamine and
tryptamine-induced core temperature changes in the rat.
BR.J.PHARMAC. 72, 477-482
- CRAGG, B.G. (1958)
Autonomic functions of the hippocampus.
NATURE 182, 675-676
- CRUICKSHANK, J.M., NEIL-DWYER, G., CAMERON, M.M. & McAINSH, J. (1980)
 β -adrenoceptor-blocking agents and the blood-brain barrier.
CLIN.SCI. 59, 453s-455s
- DAMPNEY, R.A.L. (1981)
Functional organisation of central cardiovascular pathways.
CLIN.EXP.PHARMACOL.PHYSIOL. 8, 241-259
- DAY, M.D., HEMSWORTH, B.A. & STREET, J.A. (1977)
The central uptake of β -adrenoceptor antagonists.
J.PHARM.PHARMAC. 29, (Suppl.), 52P

DAY, M.D., POYSER, R.H. & SEMPIK, J. (1980)

Drug administration into the third ventricle of the brain of anaesthetised and conscious cats.

J. PHARMACOL. METHODS 4, 71-78

DAY, M.D. & ROACH, A.G. (1973)

β -adrenergic receptors in the central nervous system of the cat concerned with control of arterial blood pressure and heart rate.

NATURE 242, 30-31

DAY, M.D. & ROACH, A.G. (1974a)

Central α - and β -adrenoceptors modifying arterial blood pressure and heart rate in conscious cats.

BR. J. PHARMAC. 51, 325-333

DAY, M.D. & ROACH, A.G. (1974b)

Cardiovascular effects of β -adrenoceptor blocking agents after intracerebroventricular administration in conscious normotensive cats.

CLIN. EXP. PHARMACOL. PHYSIOL. 1, 333-339

DAY, M.D. & ROACH, A.G. (1974c)

Central adrenoceptors and the control of arterial blood pressure.

CLIN. EXP. PHARMACOL. PHYSIOL. 1, 347-360

DE JONG, W., NIJKAMP, F.P. & BOHUS, B. (1975)

Role of noradrenaline and serotonin in the central control of blood pressure in normotensive and spontaneously hypertensive rats.

ARCH. INT. PHARMACODYN. 213, 272-284

DELBARRE, B. & SCHMITT, H. (1973) A further attempt to characterise sedative receptors activated by clonidine in chickens and mice. EUR. J. PHARM. 22, 355-9

DOLLERY, C.T., LEWIS, P.J., MYERS, M.G. & REID, J.L. (1973)

Central hypotensive effect of propranolol in the rabbit.

BR. J. PHARMAC. 48, 343P

DORWARD, P.K. & KORNER, P.I. (1978)

Effect of dl-propranolol on renal sympathetic baroreflex properties and aortic baroreceptor activity.

EUR. J. PHARMACOL. 52, 61-71

DREW, G.M., GOWER, A.J. & MARRIOT, A.S. (1979)

α_2 -adrenoceptors mediate clonidine-induced sedation in the rat.

BR. J. PHARMAC. 67, 133-141

ELY, D.L., GREENE, E.G. & HENRY, J.P. (1977)

Effects of hippocampal lesion on cardiovascular, adrenocortical and behavioural response patterns in mice.

PHYSIOL.BEHAV. 18, 1075-1083

EVANS, M.H. & WILLIAMSON, N.M. (1981)

Attenuation of the rabbit hypothalamo-cardioinhibitory response by α -adrenoceptor blocking drugs.

BR.J.PHARMAC. 72, 515P-516P

FITZGERALD, J.D., RUFFIN, R., SMEDSTAD, K.G., ROBERTS, R.

& McAINSH, J. (1978)

Studies on the pharmacokinetics and pharmacodynamics of atenolol in man.

EUR.J.CLIN.PHARMACOL. 13, 81-89

FLORAS, J.S., JONES, J.V., JOHNSTON, J.A., BROOKS, D.E., HASSAN, M.O. & SLEIGHT, P. (1978)

Arousal and the circadian rhythm of blood pressure. CLIN.SCI.MOL.MED. 55, 395s-7s

FOLKOW, B. & RUBINSTEIN, E.H. (1966)

Cardiovascular effects of acute and chronic stimulations of the hypothalamic defence area in the rat.

ACTA PHYSIOL.SCAND. 68, 48-57

Forsyth (1978)

FROHLICH, E.D. (1977)

Haemodynamics of hypertension.

In: Hypertension. Eds: Genest, J., Koiw, E. & Kuchel, O. Pp: 15-49
McGraw-Hill, New York.

↑ FORSYTH, R.P. & PESOUT, J. (1978)

Cardiovascular effects of intracerebroventricular norepinephrine in conscious and anaesthetised monkeys.

NEUROPHARMACOL. 17, 103-108

FUXE, K., LIDBRINK, P., HOKFELT, T., BOLME, P. & GOLDSTEIN, M. (1974)

Effects of piperoxane on sleep and waking in the rat. Evidence for increased waking by blocking of inhibitory adrenaline receptors on the locus coeruleus. ACTA PHYSIOL.SCAND. 91, 566-567

GAGNON, D.J. & MELVILLE, K.I. (1967)

Centrally mediated cardiovascular responses to isoprenaline.

INT.J.NEUROPHARMACOL. 6, 245-251

GALLOWAY, D.B., GLOVER, S.C., HENDRY, W.G., LOGIE, A.W., PETRIE, J.C., SMITH, M.C., LEWIS, J.A. & SIMPSON, W.T. (1976)

Propranolol in hypertension: a dose-response study.

BR.MED.J. 2, 140-142

GARVEY, H.L. & RAM, N. (1975a)

Comparative antihypertensive effects and tissue distribution of beta adrenergic blocking drugs.

J.PHARMACOL.EXP.THER. 194, 220-233

GARVEY, H.L. & RAM, N. (1975b)

Centrally induced hypotensive effects of β -adrenergic blocking drugs.

EUR.J.PHARMACOL. 33, 283-294

HARANATH, P.S.R.K., BEGUM, N.A. & SITARAMAYYA, G.V. (1965)

The effects of procaine injected into the cerebral ventricles of conscious and anaesthetised dogs.

BR.J.PHARMAC. 24, 339-347

HEINEMANN, H., STOCK, G. & SCHAEFER, H. (1973)

Temporal correlation of responses in blood pressure and motor reaction under electrical stimulation of limbic structures in unanaesthetised, unrestrained cats.

Pflügers Arch. 343, 27-40

HELLER, H. (1933)

Über die zentrale Blutdruckwirkung des Adrenalins.

NAUNYN-SCHMIEDEBERG'S ARCH.PHARMAKOL.EXP.PATHOL. 173, 291-300

HENNEMAN, E. (1980)

Motor functions of the brain stem and basal ganglia.

In: Medical Physiology. Ed: V.B.Mountcastle. 14th Edition.

Mosby, St.Louis.

HESS,W.R. & BRUGGER,M. (1943)

Das subkortikale Zentrum der affektiven Abwehrreaktion.
HELV.PHYSIOL.ACTA 1,33-52

HILTON,S.M. (1975)

Ways of viewing the central nervous control of the circulation -
old and new.

BRAIN RES. 87,213-219

HILTON,S.M. & ZBROZYNA,A.W. (1963) Amygdaloid region for defence reactions
and its efferent pathway to the brain stem. J.PHYSIOL. 165,160-173

HOKFELT,T., FUXE,K.,GOLDSTEIN,M. & JOHANSSON,O. (1973)

Evidence for adrenaline neurons in the rat brain.

ACTA PHYSIOL.SCAND. 89,286-288

HOKFELT,T., FUXE,K., GOLDSTEIN,M. & JOHANSSON,O. (1974)

Immunohistochemical evidence for the existence of adrenaline
neurons in the rat brain.

BRAIN RES. 66,235-251

ITO,A. & SCHANBERG,S.M. (1974)

Maintenance of tonic vasomotor activity by alpha and beta adrenergic
mechanisms in medullary cardiovascular centers.

J.PHARMACOL.EXP.THER. 189,392-404

JONSSON,G., MALMFORS,T. & SACHS,Ch. (1975)

Eds Chemical Tools in Catecholamine Research. Vol 1.
North-Holland Publishing Company.

KAADA,B.R. (1951)

Somato-motor, autonomic and electrocorticographic responses to
electrical stimulation of "rhinencephalic" and other structures
in primates, cat and dog.

ACTA PHYSIOL.SCAND. 24,Suppl.83

KAADA, B.R., FELDMAN, R.S. & LANGFELDT, T. (1971)
Failure to modulate autonomic reflex discharge by
hippocampal stimulation in rabbits.
PHYSIOL.BEHAV. 7, 225-231

Kakiuchi (1968)

KARPLUS, J.P. & KREIDL, A. (1909)
Gehirn und Sympathicus, I. Zwischenhirnbasis
und Halssympathicus.
PFLUGERS ARCH. 129, 138-144

KAKIUCHI, S. & RALL, T.W. (1968)
The influence of chemical agents on the accumulation of adenosine
3',5'-phosphate in slices of rabbit cerebellum.
MOL.PHARMACOL. 4, 367-378

KELLIHER, G.J. & BUCKLEY, J.P. (1970)
Central hypotensive activity of dl- and d-propranolol.
J.PHARM.SCI. 59, 1276-1280

KLEINROK, Z. & KSIAZEK, A. (1977)
The effect of β -adrenergic receptor blocking agents on
hypertensive action of noradrenaline injected into the
lateral ventricle of rat brain.
POL.J.PHARMACOL.PHARM. 29, 405-409

KLEVANS, L.R., KOVACS, J.L. & KELLY, R. (1976)
Central effect of beta adrenergic blocking agents on
arterial blood pressure.
J.PHARMACOL.EXP.THER. 196, 389-395

KOBINGER, W. (1978)
Central α -adrenergic systems as targets for hypotensive drugs.
REV.PHYSIOL.BIOCHEM.PHARMACOL. 81, 39-100

KONIG, J.F.R. & KLIPPEL, R.A. (1963)
The Rat Brain: A Stereotaxic Atlas of the Forebrain and
Lower Parts of the Brain Stem.
Williams and Wilkins, Baltimore, Maryland, USA.

KORNER,PI, DORWARD,PK, BLOMBERRY,PA & FREAN,GJ (1980)
Central nervous β -adrenoceptors and their role in the cardiovascular
action of propranolol in rabbits.
CIRC.RES. 46, (Suppl.1), 26-32

KREDIET,RT & DUNNING,AJ (1979)
Baroreceptor reflex sensitivity in hypertension
during beta-adrenergic blockade.
BR.HEART.J. 41, 106-110

KRUSZYNSKI,M, LAMMEK,B, MANNING,M, SETO,J, HALDAR,J & SAWYER,WH (1980)
(1-(β -mercapto- β , β -cyclopentamethylenepropionic acid), 2-(O-methyl
tyrosine)arginine-vasopressin and (1-(β -mercapto- β , β -cyclopenta
methylenepropionic acid)arginine-vasopressin, two highly potent
antagonists of the vasopressor response to arginine-vasopressin.
J.MED.CHEM. 23, 364-368

KUHN,DM, WOLF,WA & LOVENBERG,W (1980)
Pressor effects of electrical stimulation of the dorsal
and median raphe nuclei in anesthetised rats.
J.PHARMACOL.EXP.THER. 214, 403-409

LANGER,SZ (1977)
Presynaptic receptors and their role in
the regulation of transmitter release.
BR.J.PHARMAC. 60, 481-497

LAVY,S & STERN,S (1970)
Bradycardic effect of propranolol administered
into the central nervous system.
ARCH.INT.PHARMACODYN. 184, 257-266

LEBEL,W & WEEKS,RA (1982)
Blockade of central α_2 -adrenoceptors enhances
the carotid occlusion response in dogs.
EUR.J.PHARMACOL. 79, 79-89

LEWIS,P (1976)

The essential action of propranolol in hypertension.
AM.J.MED. 60,837-852

LEWIS,PJ & HAEUSLER,G (1975)

Reduction in sympathetic nervous activity as a
mechanism for hypotensive effect of propranolol.
NATURE 256,440

LIDDELL,EGT (1934)

Spinal shock and some features in isolation-
alteration of the spinal cord in cats.
BRAIN 57,386

LOEWY,AD & McKELLAR,S (1980)

The neuroanatomical basis of central cardiovascular control.
FED.PROC. 39,2495-2503

MANN,S, MILLAR CRAIG,MW, MELVILLE,DI, BALASUBRAMANIAN,V
& RAFTERY,EB (1979)

Physical activity and the circadian rhythm of blood pressure.
CLIN.SCI. 57,291s-294s

McCUBBIN,JW, KANEKO,Y & PAGE,IH (1960)

Ability of serotonin and norepinephrine to mimic the
central effects of reserpine on vasomotor activity.
CIRC.RES. 8,849-858

MERLIS,JK (1940)

The effect of changes in the calcium content of cerebrospinal
fluid on spinal reflex activity in the dog.
AM.J.PHYSIOL. 13,67-72

MICHELAKIS,AM & McALLISTER,RG (1972)

The effect of chronic adrenergic receptor blockade on plasma renin activity in man.

J.CLIN.ENDOCRINOL.METAB. 34, 386-394

MIDDLEMISS, DN, BLAKEBOROUGH, L & LEATHER, SR (1977)

Direct evidence for an interaction of β -adrenergic blockers with the 5-HT receptor.

NATURE 267, 289-290

MONTASTRUC, J-L & MONTASTRUC, P (1980)

Effect of intracisternal application of 6-hydroxydopamine on the antihypertensive action of propranolol in the dog.

EUR.J.PHARMACOL. 63, 103-116

MOORE, RY & BLOOM, FE (1979)

Central catecholamine neuron systems: anatomy and physiology of the norepinephrine and epinephrine systems.

ANN.REV.NEUROSCI. 2, 113-168

MORGAN, TO, ROBERTS, R, CARNEY, SL, LOUIS, WJ & DOYLE, AE (1975)

β -adrenergic receptor blocking drugs, hypertension and plasma renin.

BR.J.CLIN.PHARMACOL. 2, 159-164

NASHOLD, BS, MANNARINO, E & WUNDERLICH, M (1962)

Pressor-depressor blood pressure responses in the cat after intraventricular injection of drugs.

NATURE 193, 1297-1298

NIJKAMP, FP, VAN DEN BOSCH, R & DE JONG, W (1979)

An opposing role for the adrenals in the hypotensive effects of propranolol in the spontaneously hypertensive rat.

EUR.J.PHARMACOL. 56, 187-195

O'DONNELL,SR & WANSTALL,JC (1980)

Evidence that ICI 118551 is a potent, highly beta₂-selective adrenoceptor antagonist and can be used to characterize beta-adrenoceptor populations in tissues.

LIFE SCIENCES 27,671-677

OFFERHAUS,L & VAN ZWIETEN,PA (1974)

Comparative studies on central factors contributing to the hypotensive action of propranolol, alprenolol, and their enantiomers.

CARDIOVAS.RES. 8,488-495

OLDENDORF,WH (1974)

Blood-brain barrier permeability to drugs.

ANN.REV.PHARMACOL. 14,239-248

OZAWA,H & UEMATSU,T (1975)

Centrally mediated cardiovascular responses to intracisternal injections of sympathomimetic amines in anaesthetised rats.

JAP.J.PHARMAC. 26,45-56

PELLEGRINO,L & CUSHMAN,AJ (1971)

Use of the stereotaxic technique.

In: Methods in Psychobiology, Vol.1. Ed: RD Myers.

Academic Press, New York.

PHILIPPU,A (1980)

Regulation of the arterial blood pressure.

In: Handbook of Experimental Pharmacology, Vol.54, Pp: 521-548

Ed: L Szekeres. Springer-Verlag, Berlin.

PHILIPPU,A & KITTEL,E (1977)

Presence of beta-adrenoceptors in the hypothalamus; their importance for the pressor response to hypothalamic stimulation.

NAUNYN-SCHMIEDEBERG'S ARCH.PHARMACOL. 297,219-225

PHILIPPU,A & STROEHL,U (1978)

Beta-adrenoreceptors of the posterior hypothalamus.
CLIN.EXP.HYPERTENSION 1,25-38

PHILLIPS,DK (1980)

Chemistry of alpha- and beta-adrenoceptor agonists and antagonists. In: Adrenergic Activators and Inhibitors, Part 1.
Pp: 3-61. Ed: L Szekeres. Springer-Verlag, Berlin.

PICKERING,TG, GRIBBEN,B, PETERSON,ES, CUNNINGHAM,DJC
& SLEIGHT,P (1972)

Effects of autonomic blockade on the baroreflex in man
at rest and during exercise.
CIRC.RES. 30,177-185

POWELL,CE & SLATER,IH (1958)

Blocking of inhibitory adrenergic receptors by a
dichloro analog of isoproterenol.
J.PHARMACOL.EXP.THER. 122,480-488

PRICE,HL. & PRICE,ML (1966)

Effects of general anaesthetics on contractile
response of rabbit aortic strips.
ANESTHESIOLOGY 23,16-20

PRICHARD,BNC & GILLAM,PMS (1964)

The use of propranolol in the treatment of hypertension.
BR.MED.J. 2,725-727

PRIVITERA,PJ, WEBB,JG & WALLE,T (1979)

Effects of centrally administered propranolol on plasma renin
activity, plasma norepinephrine and arterial pressure.
EUR.J.PHARMACOL. 54,51-60

RAINE,AEG & CHUBB,IW (1977)

Long term β -adrenergic blockade reduces tyrosine hydroxylase and dopamine β -hydroxylase activities in sympathetic ganglia. NATURE 267,265-267

RAM,N, HESSE,UC & HEILMAN,RD (1977)

The effects of propranolol HCl in hippocampal-lesioned rats. ARCH.INT.PHARMACODYN. 229,138-143

RAVENTOS,J (1956)

The action of Fluothane - a new volatile anaesthetic. BR.J.PHARMAC. 11,394-410

REID,JL, LEWIS,PJ, MYERS,MG & DOLLERY,CT (1974)

Cardiovascular effects of intracerebroventricular d-,l- and dl-propranolol in the conscious rabbit. J.PHARMACOL.EXP.THER. 188,394-399

ROBISON,GA, BUTCHER,RW & SUTHERLAND,EW (1971)

Cyclic AMP
Academic Press, New York.

ROTHMAN,AR, FREIREICH,EJ, GASKINS,JR, PATLAK,CS & RALL,DP (1961)

Exchange of inulin and dextran between blood and cerebrospinal fluid. AM.J.PHYSIOL. 201,1145-1148

SCHANKER,LS (1962)

Passage of drugs across body membranes. PHARMACOL.REV. 14,501-530

SCHMITT,H & FENARD,S (1971)

Effets des substances sympathomimetiques sur les centres vasomoteurs. ARCH.INT.PHARMACODYN. 190,229-240

SCHMITT,H, SCHMITT,H & FENARD,S (1971)

Evidence for an α -sympathomimetic component in the effects of catapresan on vasomotor centres: antagonism by piperoxane. EUR.J.PHARMACOL. 14,98-100

SCOTT,EM (1981)

The effects of atenolol on spontaneous and reflex activity of the sympathetic nerves in the anaesthetised cat. BR.J.PHARMAC. 73,609-616

SHARE,NN (1973)

"Alpha" and "beta" adrenergic receptors in the medullary vasomotor center of the cat. ARCH.INT.PHARMACODYN. 202,362-373

SHARE,NN & MELVILLE,KI (1963)

Centrally mediated sympathetic cardiovascular responses induced by intraventricular norepinephrine. J.PHARMACOL.EXP.THER. 141,15-21

SHARMA,JN, SANDREW,BB & WANG,SC (1979)

CNS site of β -adrenergic blocker-induced hypotension in the cat: a microiontophoretic study of bulbar cardiovascular neurones. NEUROPHARMACOLOGY 18,1-5

SHERIDAN,RD (1982)

A relatively inexpensive combined stimulus isolation/constant current device. BR.J.PHARMAC. 75, (Suppl.), 115P

SIMON,G, KIOWSKI,W & JULIUS,S (1977)

Effect of beta-adrenoceptor antagonists on baroreceptor reflex sensitivity in hypertension. CLIN.PHARMAC.THER. 22,293-298

SMITS, JFM, STRUYKER BOUDIER, HAJ & VAN ESSEN, H (1980)
Effects of propranolol on baroreceptor reflex sensitivity
in the conscious spontaneously hypertensive rat (SHR).
BR. J. PHARMAC. 68, 109P

SMITS, JFM, VAN ESSEN, H & STRUYKER BOUDIER, HAJ (1978)
Serotonin-mediated cardiovascular responses to electrical
stimulation of the raphe nuclei in the rat.
LIFE SCI. 23, 173-178

SMITS, JFM, VAN ESSEN, H & STRUYKER BOUDIER, HAJ (1979)
Propranolol in conscious spontaneously hypertensive rats.
I. Cardiovascular effects after subcutaneous and intracerebro-
ventricular administration.
NAUNYN-SCHMIEDEBERG'S ARCH. PHARMACOL. 309, 13-18

SMITS, JFM, VAN ESSEN, H & STRUYKER BOUDIER, HAJ (1980a)
Is the antihypertensive effect of propranolol caused by an
action within the central nervous system?
J. PHARMACOL. EXP. THER. 215, 221-225

SNIDER, RS & NIEMER, WT (1961)
A Stereotaxic Atlas of the Cat Brain.
University of Chicago Press, Chicago.

SRIVASTAVA, RK, KULSHRESTHA, VK, SINGH, N & BHARGAVA, KP (1973)
Central cardiovascular effects of
intracerebroventricular propranolol.
EUR. J. PHARMACOL. 21, 222-229

STERN, S, HOFFMAN, M & BRAUN, K (1971)
Cardiovascular response to carotid and vertebral artery
infusion of propranolol.
CARDIOVAS. RES. 5, 425-430

STJARNE, L & BRUNDIN, J (1976)
 β_2 -adrenoceptors facilitating noradrenaline secretion
from human vasoconstrictor nerves.
ACTA PHYSIOL. SCAND. 97, 88-93

- STOKES,GS, WEBER,MA & THORNELL,IR (1974)
 β -blockers and plasma renin activity in hypertension.
BR.MED.J. 1,60-62
- STRUYKER BOUDIER,HAJ & BEKERS,AD (1975)
Adrenaline-induced cardiovascular changes after
intra-hypothalamic administration to rats.
EUR.J.PHARMACOL. 31,153-155
- STRUYKER BOUDIER,HAJ, SMEETS,G, BROUWER,G, & VAN ROSSUM,JM (1975)
Central nervous system α -adrenergic mechanisms
and cardiovascular regulation in rats.
ARCH.INT.PHARMACODYN. 213,285-293
- SUGAWARA,K, TAKAMI,N, MAEMURA,S, NIWA,M & OZAKI,M (1980)
 β -adrenoceptor blocking agents release catecholamines
from rat adrenal medulla.
EUR.J.PHARMACOL. 62,287-295
- SWEET,CS & WENGER,HC (1976)
Central antihypertensive effects of propranolol
in the spontaneously hypertensive rat.
NEUROPHARMACOLOGY 15,511-513
- SZABADI,E (1979)
Adrenoceptors on central neurones: microelectrophoretic studies.
NEUROPHARMACOLOGY 18,831-843
- TAHER,MS, McLAIN,LG, McDONALD,KM & SCHRIER,RW (1976)
Effect of beta adrenergic blockade on renin response
to renal nerve stimulation.
J.CLIN.INVEST. 57,459-465

TAKESHITA,A, TANAKA,S & NAKAMURA,M (1978)

Effects of propranolol on baroreflex sensitivity
in borderline hypertension.

CARDIOVAS.RES. 12,148-151

TARAZI,RC & DUSTAN,HP (1972)

Beta adrenergic blockade in hypertension.

AM.J.CARDIOL. 29,633-640

TAYLOR,EA, JEFFERSON,D, CARROLL,JD & TURNER,P (1981)

Cerebrospinal fluid concentrations of propranolol, pindolol
and atenolol in man: Evidence for central actions of
 β -adrenoceptor antagonists.

BR.J.CLIN.PHARMAC. 12,549-559

TOCCO,DJ, CLINESCHMIDT,BV, DUNCAN,AEW, deLUNA,FA & BAER,JE (1980)

Uptake of the beta-adrenergic blocking agents propranolol
and timolol by rodent brain: relationship to
central pharmacological actions.

J.CARDIOVAS.PHARMACOL. 2,133-143

TODA,N, MATSUDA,Y & SHIMAMOTO,K (1969)

Cardiovascular effects of sympathomimetic amines
injected into the cerebral ventricles of rabbits.

INT.J.NEUROPHARMACOL. 8,451-461

TORII,S & KAWAMURA,H (1960)

Effects of amygdaloid stimulation on blood pressure
and electrical activity of hippocampus.

JAP.J.PHYSIOL. 10,374-384

TRINER,L, VULLIEMOZ,Y, VEROSKY,M & MANGER,WM (1975)

Cyclic adenosine monophosphate and vascular reactivity
in spontaneously hypertensive rats.

BIOCHEM.PHARMAC. 24,743-745

ULRYCH,M, FROHLICH,ED, DUSTAN,HP & PAGE,IH (1968)
Immediate hemodynamic effects of beta-adrenergic blockade
with propranolol in normotensive and hypertensive man.
CIRCULATION 37,411-416

UNGERSTEDT,U (1971)
Stereotaxic mapping of the monoamine pathways
in the rat brain.
ACTA PHYSIOL.SCAND. 367,1-48

URANO,A & KOBAYASHI,H (1978)
Effects of noradrenaline and dopamine injected into the
supraoptic nucleus on urine flow in hydrated rats.
EXP.NEUROL. 60,140-150

UVNAS,B (1960)
Central cardiovascular control.
In: Handbook of Physiology, Section 1, Neurophysiology, Vol.II.
Pp: 1131-1162. Eds: J.Field, HW Magoun & VE Hall.
American Physiological Society, Washington DC.

WEINBERGER,MH, AOI,W & HENRY,DP (1975)
Direct effect of beta adrenergic stimulation
on renin release by the rat kidney in vitro.
CIRC.RES. 37,318-324

WEPIERRE,J, LINDENBAUM,A, PORQUET,D & COHEN,Y (1978)
Hypotensive action of beta-blocking drugs injected
into the cerebral ventricle of the rat.
ARCH.INT.PHARMACODYN. 232,158-165

WIETHOLD,G, HELLENBRECHT,D, LEMMER,B & PALM,D (1973)
Membrane effects of beta-adrenergic blocking agents:
investigations with the fluorescence probe 1-anilino-8-naphthalene
sulfonate (ANS) and antihemolytic activities.
BIOCHEM.PHARMAC. 22,1437-1449

APPENDIX

Publications

In order of inclusion in the Appendix:

SHERIDAN, RD (1979)

Blood pressure - the heart of the matter.

NEW SCIENTIST 84, 529-531

CLOUGH, DP, DRAPER, AJ, REDFERN, PH & SHERIDAN, RD (1981)

The effect of β -blockade on the cardiovascular responses to centrally-administered adrenaline in the rat.

BR.J.PHARMAC. 74, 934P-935P

CLOUGH, DP, DRAPER, AJ, REDFERN, PH & SHERIDAN, RD (1981)

The effects of centrally-administered adrenaline on rat blood pressure - modification by selective β -adrenoceptor blockade.

J.PHARM.PHARMAC. 33, (Suppl.), 41P

CLOUGH, DP, DRAPER, AJ, REDFERN, PH & SHERIDAN, RD (1981)

Effects of centrally-injected β -blockers on the pressor responses to electrical stimulation in the posterior hypothalamus and medial raphe nucleus of the anaesthetised.

J.PHARM.PHARMAC. 33, (Suppl.), 91P

SHERIDAN, RD (1982)

A relatively inexpensive combined stimulus isolation/constant current device.

BR.J.PHARMAC. 75, (Suppl.), 115P

Blood pressure — the heart of the matter

Diseases of the heart and circulation are major killers in affluent society. One mysterious complaint is known as essential hypertension—high blood pressure with no obvious cause

Robert Sheridan is in the Department of Pharmacology at the University of Bath

Our understanding of the way blood circulates has advanced enormously since William Harvey made his pioneering observations some 350 years ago. But there are aspects of the cardiovascular system that puzzle us still. Essential hypertension, in which blood pressure is raised for no obvious reason, is one such puzzle. In this article I want to look at blood pressure in some detail. If we know how the body controls blood pressure we can understand how it becomes elevated and how to control that elevation.

When a person is at rest his heart beats roughly 70 times each minute. In doing so it provides the driving force that propels blood around two linked circuits: the pulmonary circulation, which sends spent blood to the lungs where it absorbs oxygen; and the systemic circulation, which ensures that oxygenated blood gets to all parts of the body.

The heart is a double pump at the centre of the two circuits (Figure 1). Each time the heart contracts (called systole), the left ventricle pumps about 75 millilitres of oxygen-saturated blood into the aorta, the first and largest artery in the systemic circulation. The maximum pressure that is reached in the aorta, known as the systolic blood pressure (Figure 2), will depend on the amount of blood ejected, the rate at which it is ejected, and the "stretchability" (compliance) of the muscular wall of the aorta. A large volume of blood ejected quickly into a rigid aorta will produce a higher maximum systolic pressure than a smaller amount of blood pumped more slowly into a compliant aorta.

After each contraction the heart relaxes. This is called diastole. During this time the left atrium, which receives oxygenated blood from the lungs, empties into the left ventricle. The valve between the aorta and the ventricle shuts and the pressure in the aorta falls. The rate at which the pressure falls depends on the systolic pressure and on the resistance to flow of the smaller vessels downstream. Pressure in the aorta keeps dropping until the next contraction, when a fresh volume of blood is pumped into the vessels. The minimum pressure, just before a contraction, is called the diastolic blood pressure (Figure 2).

Doctors normally measure both systolic and diastolic pressures, and refer to blood pressure by the two figures. Thus a blood pressure of 120/80 represents a maximum (systolic) pressure of 120 mm of mercury and a minimum (diastolic) pressure of 80 mm of mercury.

The pressure in the blood vessels falls continuously from the aorta to the end of the systemic circulation in the right atrium. If it did not, blood would not flow around the body. But the pressure drop is not linear along the circulation path; the greatest drop occurs in the smallest arteries, the arterioles, just upstream of the capillaries. Because the precapillary arterioles are small, they offer a great resistance to flow through them, but relatively small changes in the diameter of the arterioles can dramatically alter the rate of flow. For these reasons the arterioles and other so-called precapillary resistance vessels are ideal places at which to regulate arterial blood pressure. Not surprisingly then, this is their major function.

The precapillary resistance vessels receive nerves from the sympathetic division of the autonomic nervous system. (The autonomic nervous system regulates bodily functions over which most people have little voluntary control. It is divided into the sympathetic and parasympathetic systems, and these normally act in opposition. For example,

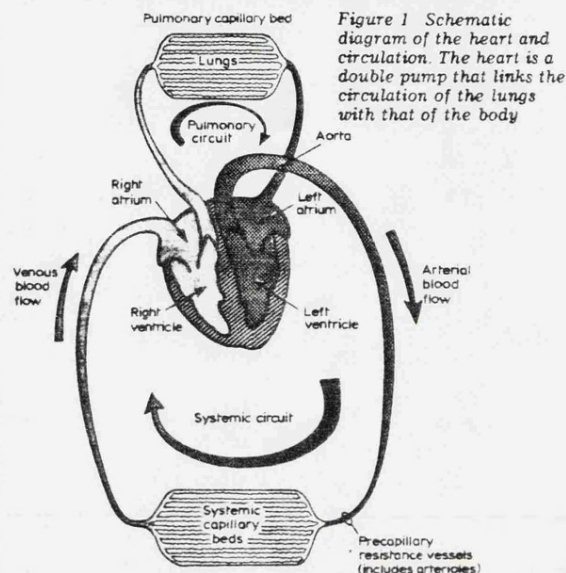

Figure 1 Schematic diagram of the heart and circulation. The heart is a double pump that links the circulation of the lungs with that of the body

activity in the sympathetic nerves causes the heart to beat faster, while the parasympathetic nerves cause it to slow down.) When the nerves to the blood vessels "fire", the muscles in the arteriole walls contract. This reduces the diameter of the vessel and so increases its resistance to blood flow. If the precapillary resistance vessels contract there is an increase in total peripheral resistance, which means that a higher arterial blood pressure is needed to move an amount of blood through the system at a particular speed.

After this gallop around the circulatory system we can pause to consider just what might cause high blood pressure. We know that the speed at which the pressure falls from systolic maximum depends partly on the total peripheral resistance to flow. When this resistance is high the pressure falls slowly and the diastolic pressure is correspondingly higher. Sustained diastolic hypertension (raised minimum blood pressure) is a common symptom of a variety of diseases, for example kidney disease, but in over 95 per cent of people the cause for elevated diastolic pressure remains unknown. It is this condition that goes by the name of primary, or essential, hypertension.

One thing consistent to all cases of essential hyper-

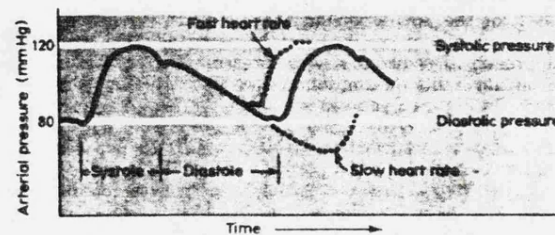

Figure 2 Pressure in the main arteries rises and falls as the heart contracts and relaxes

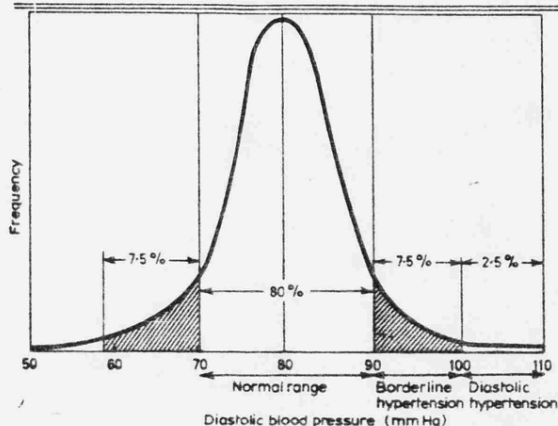

Figure 3 Frequency curve for diastolic blood pressure in the population reveals the limits doctors commonly use to make their diagnoses

tension is that resistance vessels all over the body are more constricted than they are in a normal person. The cause of this generalised constriction is not known, but one general hypothesis is that some people have a genetic predisposition to over-react to the chemicals that constrict the blood vessels. In these people the peripheral resistance vessels might, because of their reactivity and prolonged exposure to constricting influences, undergo some permanent change that results in them presenting a higher than normal total peripheral resistance.

Blood pressure must stay within certain limits for molecular exchange between cells and blood to take place in the capillaries. Without knowing why this is so, we do know from life assurance statistics that life expectancy varies inversely with blood pressure; the higher your blood pressure the sooner you are likely to die.

One consequence of a raised total peripheral resistance is that the heart must work harder to maintain a normal flow of blood through the tissues. The heart is a muscle, and when muscles are forced to work they grow. Bigger muscles need more oxygen, as do muscles that are working hard. So any interruption to the supply of blood to the heart itself—the so-called coronary blood supply—will be much more serious in the overgrown overworked heart of a hypertensive than in the smaller heart of a normal person. It is for this reason that one of the major problems of uncontrolled high blood pressure is the death of a block of heart muscle as a result of the blood supply being blocked (myocardial infarction). Other problems include stroke and kidney damage. It is because of these complications that high blood pressure must be lowered.

How high is high?

It is all very well to say that we should treat high blood pressure, but first we must decide what level constitutes "high". Blood pressure varies from person to person, so that for the population as a whole there is a distribution of blood pressures. We can therefore adopt a statistical approach. If someone's blood pressure lies outside certain arbitrary limits we can define it as too high, and act accordingly. In Figure 3 you can see a distribution curve for blood pressure in a hypothetical population. Eighty per cent of all observations are said to be normal; 15 per cent are then "borderline" and 5 per cent are either hypo- or hypertensive. Of course you need different curves for different populations—defined according to age, sex, and so on—but with such a family of curves it is possible to get a rough guide to the abnormality of an individual's blood pressure. The doctor must, however, also be prepared to temper his

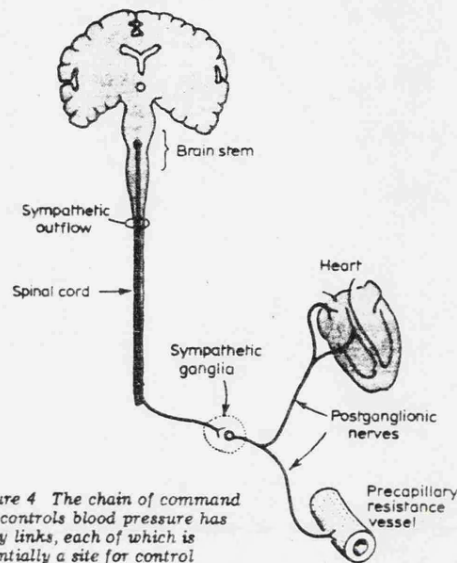

Figure 4 The chain of command that controls blood pressure has many links, each of which is potentially a site for control

statistical observations with knowledge of the patient.

Doctors normally speak of three increasingly dangerous classes of hypertension; mild, moderate, and severe. In mild hypertension there is no clinically detectable impairment of either the heart or the kidneys; blood pressure is higher than normal, but otherwise nothing seems to be wrong. Increasingly high blood pressures bring increased complications. In moderate hypertension the kidneys are not doing their job well and the heart is having to work harder in the face of increased total peripheral resistance. Finally, in severe hypertension, the heart is very enlarged, the kidneys have deteriorated further, and total peripheral resistance is even higher.

The prime purpose of drug treatment to combat hypertension is to bring the blood pressure down to more normal values. The idea is to lower the total peripheral resistance, which should take the load off the heart and improve blood flow through the kidneys.

The first weapon in the anti-hypertensive arsenal is usually a drug that increases the production of urine; this also eliminates sodium from the body and lowers blood pressure, though exactly how is unclear. If this doesn't work, more powerful weapons are available. These drugs act at a variety of different sites in the body; they may act directly, to relax the muscles in the resistance vessels; they may affect the transmission of impulses down the sympathetic nerves to the vessels; they may inhibit the sympathetic nerve ganglia; or they may act in the brain to reduce sympathetic activity centrally. All these actions will bring down blood pressure by opening out the arterioles, thereby lowering total peripheral resistance (Figure 4).

There remains the problem of whether it is actually worth treating the patient who suffers only mild hypertension. Every available anti-hypertensive drug has some side-effects, and the doctor has to balance the risks and benefits of drug treatment against the risk of untreated hypertension, albeit mild hypertension. At present we just don't have all the information we need to perform this balancing act. There is a distinct shortage of evidence from long-term drug trials in mild hypertension, so that doctors are more or less on their own in deciding whether to put someone whose high blood pressure is mild, rather than severe, onto anti-hypertensive drugs.

Side-effects pose one set of problems. Another arises because patients won't take their drugs. The trouble is that the milder forms of hypertension are notoriously asymptomatic; they cause the patient very little, if any, discomfort so there is a great temptation to stop taking the prescribed medication. And if the patient does stop taking the tablets he is unlikely to *feel* any worse. Indeed, because of side-effects, the patient may actually feel better when he stops taking the drugs. Doctors can not do very much about this. They have to make sure that they get the maximum lowering of blood pressure with minimum side-effects, and stress to the patient the importance of continuing therapy.

An astonishing number of studies have tried to discover just what causes some people to develop essential hypertension. Studies of hypertensive families confirm that there may well be a strong hereditary component to the disease, but the actual mode of inheritance remains, to put it kindly, obscure. A multitude of factors play a part in the development of the disease, and as far as genetics is concerned perhaps all we can safely say is that if both parents are hypertensive there is significantly greater risk that their children will eventually also develop high blood pressure.

Predisposing factors

Other predisposing factors are more obvious. Doctors have long known that obese people tend to have high blood pressure, just as hypertensives tend to be overweight. What isn't clear is whether the increased body fat itself causes hypertension or whether there is some other factor that relates to both obesity and blood pressure.

Salt has been implicated in hypertension, and one of the first effective ways to lower blood pressure was to restrict the amount of salt a patient ate. The problem here is that a salt-free diet is unutterably boring, and requires enormous will-power from the patient.

Smoking, too, is a definite danger in all things to do with the heart and circulation. Hypertensives should not smoke because nicotine mimics the action of the sympathetic nerves, constricting the arterioles and thereby raising the total peripheral resistance.

Obesity, salt and tobacco all play their part in high blood pressure, as do a number of other factors. There is some evidence that a certain type of person tends to become hypertensive. These are people who respond to stress to a greater degree than normal. There is no doubt that stress activates the sympathetic nervous system, and if this activation is prolonged it could lead to more or less permanent changes in the cardiovascular system. As an example, let me mention the body's own pressure receptors. These "baroreceptors" are found in the aorta and in the main artery leading to the brain. They respond to changes in blood pressure, and send information to the centres in the brain that control blood pressure to adjust the pressure back to normal, just one of many negative feedback systems common in physiology. It is possible that prolonged stress eventually causes the baroreceptors to become reset to a lower sensitivity level, so that a greater change in blood pressure must take place before the reflex feedback system swings into operation.

Whatever the causes of essential hypertension, its prevalence in affluent societies means that the market for anti-hypertensive drugs is enormous. The pharmaceutical companies are in intense competition to develop safer, more effective drugs, and they pour a huge amount of money into research. Currently there is a lot of interest in drugs that lower blood pressure by acting on selected sites in the brain, and this looks to be a very promising area. There is even a strain of genetically hypertensive rats that makes testing new compounds a little easier. In all, it seems that though we still don't really understand essential hypertension, the outlook for the hypertensive patient can only improve. □

The TECHNOLOGY WRITERS' Awards

Entries are now requested for the 1979 Awards. If you write professionally about technology for professional periodicals, trade or technical magazines, national or regional newspapers, radio or television, you should enter now for the 1979 Technology Writers' Awards. Sponsored by ITT Business Systems under the auspices of the Association of British Science Writers, the Awards will be presented in three categories:

- (i) an overall winner from any medium - prize £1500
- (ii) a specialist publication award - prize £750
- (iii) a broadcasting award - prize £750

Entrants are required to submit six legible copies of the articles or in the case of radio and television, scripts they wish the judges to consider. In the case of radio and television work, tapes will be required to be available at the second stage of judging. If a radio or television entry wins the overall award, the award of £750 can be made, at the judges' discretion, to another category.

Any material published or broadcast in the United Kingdom between 1st January and December 31st, 1979, is eligible for the Awards.

Entry is by submission and should be sent by 31st January 1980 to:

The Organiser,
The Technology Writers' Awards,
MPR Limited,
293 Gray's Inn Road,
London WC1X 8QR.

The
TECHNOLOGY WRITERS'
Awards

Sponsored by ITT Business Systems under the auspices of the Association of British Science Writers.

CELESTRON ASTRONOMICAL TELESCOPES



Astronomy is one of today's most rewarding and fascinating pastimes. Even with the smallest of our telescopes you will be able to view the planets and star systems in remarkable detail and clarity. Charles Frank have over 80 years experience in the field of astronomy and are renowned for their sound and knowledgeable advice on telescope systems for the beginner right up to the experienced enthusiast. Send now for the beautifully illustrated Celestron Catalogue: £1.00. Details of Charles Frank's own binoculars, terrestrial telescopes and astro components are available free on request.

Prices from **£705** (3½" model) to **£5,400** (14" model)

Sole UK Distributors

Charles Frank LTD.
DEPT. NS, P.O. Box 5, RONALD LANE,
SAXMUNDHAM, SUFFOLK IP17 2NL
TEL: 0728 3506

Table 1 The interaction of clonidine with yohimbine and its diastereoisomers in the conscious SHR

Dose given i.c.v.	Max % Δ from resting levels		n
	B.P. \pm s.e.mean	H.R. \pm s.e.mean	
Clonidine (1 μ g)	-14.2 \pm 5.2	-8.2 \pm 4.1	6
Clonidine (2 μ g)	-20.4 \pm 5.1	-14.5 \pm 3.3	6
Clonidine (4 μ g) + vehicle	-33.7 \pm 4.2	-23.7 \pm 4.2	6
Clonidine (8 μ g)	-40.0 \pm 1.9	-35.4 \pm 3.3	6
Clonidine (4 μ g)			
+ corynanthine (25 μ g)	-30.1 \pm 4.1	-23.2 \pm 4.1	6
corynanthine (50 μ g)	-23.2 \pm 2.8	-19.2 \pm 4.3	6
corynanthine (100 μ g)	-14.8 \pm 1.8**	-7.8 \pm 6.7	6
+ yohimbine (25 μ g)	-21.2 \pm 2.1*	-14.5 \pm 2.4	6
yohimbine (50 μ g)	-17.5 \pm 4.3*	-9.1 \pm 4.2*	6
yohimbine (100 μ g)	-7.8 \pm 1.8**	-3.8 \pm 1.9**	6
+ rauwolscine (25 μ g)	-15.4 \pm 1.6**	-11.7 \pm 2.7*	6
rauwolscine (50 μ g)	-6.3 \pm 2.0**	-4.4 \pm 3.2**	6
rauwolscine (100 μ g)	-2.6 \pm 3.8**	+3.6 \pm 4.1**	6

*Significantly different from controls $P < 0.05$, unpaired students t -test.

**Significantly different from controls $P < 0.01$, unpaired students t -test.

Resting M.A.P. and H.R. = 168.9 \pm 10.3 mmHg and 379.3 \pm 16.3 beats/min respectively (Mean \pm s.e.mean, $n = 15$).

P.J.B. is supported by a S.R.C. CASE award with Pfizer Ltd.

References

- BECKETT, P.J. & FINCH, L. (1981). The involvement of central α_1 and α_2 adrenoceptors in the cardiovascular effects of clonidine and R28935 in the conscious cat. British Pharmacological Society meeting, Bradford, April, 1981.
- BORKOWSKI, K.R. & FINCH, L. (1978). Cardiovascular responses to intraventricular adrenaline in spontaneously hypertensive rats. *Eur. J. Pharmac.*, **47**, 281-290.
- KOBINGER, W. (1978). Central α -adrenergic systems as targets for hypotensive drugs. *Rev. Physiol. Biochem. Pharmac.*, **81**, 39-100.
- ROCKHOLD, R.W. & GROSS, F. (1981). Yohimbine Diastereoisomers: Cardiovascular effects after central and peripheral application in the rat. *Naunyn-Schmiedeberg's Arch. Pharmac.*, **315**, 227-231.
- TIMMERMANS, P.B.W.M., SCHOOP, A.M.C., KWA, H.Y. & VAN ZWIETEN, P.A. (1981). Characterisation of α -adrenoceptors participating in the central hypotensive and sedative effects of clonidine using yohimbine, rauwolscine and corynanthine. *Eur. J. Pharmac.*, **70**, 7-15.
- WEITZELL, R., TANAKA, T. & STARKE, K. (1979). Pre- and postsynaptic effects of yohimbine stereoisomers on noradrenaline transmission in the pulmonary artery of the rabbit. *Naunyn-Schmiedeberg's Arch. Pharmac.*, **308**, 127-136.

The effect of β -blockade on the cardiovascular responses to centrally-administered adrenaline in the rat

D.P. CLOUGH*, A.J. DRAPER,
P.H. REDFERN & R.D. SHERIDAN

*Pharmacology Group, School of Pharmacy and Pharmacology, University of Bath, Claverton Down, Bath BA2 7AY and *Bioscience Department II, Imperial Chemical Industries Ltd, Pharmaceuticals Division, Alderley Park, Macclesfield, Cheshire*

Although a considerable body of circumstantial evidence points to a central component in the anti-hypertensive action of β -blocking drugs, the results of experiments designed to test this hypothesis are equivocal. For example, intracerebroventricular (i.c.v.) injection of propranolol in the rat was reported by Wepierre, Lindenbaum, Porquet & Cohen (1978) to cause a fall in blood pressure, whereas Sweet, Scriabine, Wenger, Ludden & Stone (1976) reported a transient rise. Similar experiments with other species have yielded equally ambivalent results. In an attempt to delineate further the central

actions of β -blocking drugs on the cardiovascular system, we have used i.c.v. adrenaline as an agonist capable of stimulating both α and β receptors, and possibly even specific adrenaline-receptors, and have investigated the ability of centrally-administered β -blocking drugs to modify the cardiovascular responses to i.c.v. adrenaline.

Male Wistar rats (Alderley Park strain) weighing 220-270 g were anaesthetized with thiobutobarbitone sodium ('Inactin', BYK Ltd) i.p. at a dose of 100 mg/kg. Blood pressure was recorded from a carotid artery and heart rate was derived from the blood pressure pulse. All drugs were injected through a 30 gauge stainless steel cannula inserted by means of a David Kopf stereotaxic instrument into the left lateral cerebral ventricle (co-ordinates A 3.29, L 4.4, H-O. 4 mm; König & Klippel, 1963). Adrenaline hydrogen tartrate (BDH), freshly dissolved in artificial CSF at a concentration of 4 mg/ml, was injected at a rate of 2 μ l/min. The total dose of 20 μ g was thus contained in 5 μ l. The β -blockers (\pm -propranolol HCl, \pm -atenolol; I.C.I. Ltd), or +-propranolol HCl (I.C.I. Ltd) were administered by the same route in a volume of 10 μ l, the injections beginning 15 min and ending 10 min before the adrenaline injection.

Administered in this way 20 μ g adrenaline alone was without effect on mean arterial pressure (MAP) but reduced heart rate by some 20-30 beats per min. When preceded by 30 μ g \pm -propranolol, however, the same dose of adrenaline produced a sustained rise in MAP of 32 ± 3 mmHg ($n = 7$). This pressor response was dependent on the dose of propranolol within the range 10-100 μ g; these doses of propranolol did not themselves alter MAP. A similar dose-relationship was observed with atenolol pre-treatment; after atenolol (100 μ g), adrenaline (20 μ g) increased MAP by 45 ± 8 mmHg ($n = 7$), an effect comparable in magnitude to that seen after the same dose of propranolol, though of shorter duration.

That the ability of propranolol to unmask the pressor response to adrenaline was dependent on blockade of β -receptors was shown by the lack of

response to adrenaline following 30 μ g d-propranolol.

That the effect of the β -blockers is mediated centrally was shown by comparing the effect of atenolol, which does not readily cross the blood-brain barrier (Day, Hemsworth & Street, 1977), administered intravenously and i.c.v.; centrally injected adrenaline produced no pressor response after atenolol (100 μ g i.v.).

Assuming, therefore, a central locus of action for both adrenaline and the β -blocking drugs, these results suggest that adrenaline may exert both an inhibitory and an excitatory action on MAP. The inhibitory effect appears to be mediated via an action on β -receptors and when this effect is prevented by central β -receptor blockade, the pressor response is revealed. The identity and location of the receptors responsible for this pressor response are currently being investigated.

Support from S.R.C. and I.C.I. Ltd, in the form of a CASE studentship to R.D. Sheridan, is gratefully acknowledged.

References

- DAY, M.D., HEMSWORTH, B.A. & STREET, J.A. (1977). The central uptake of β -adrenoceptor antagonists. *J. Pharm. Pharmacol.*, **29**, Suppl. 52P.
- KÖNIG, J.F.R. & KLIPPEL, R.A. (1963). *The Rat Brain*. Williams and Wilkins, Baltimore.
- SWEET, C.S., SCRIBINE, A., WENGER, H.C., LUDDEN, C.T. & STONE, C.A. (1976). Comparative antihypertensive effects of i.c.v. injection versus oral administration of β -adrenergic receptor blocking drugs in the spontaneously hypertensive rat. In: *Regulation of blood pressure by the central nervous system*. eds Onesti, G., Fernandes, M. & Kim, K. pp. 317-334. New York: Grune and Stratton.
- WEPIERRE, J., LINDENBAUM, A., PORQUET, D. & COHEN, Y. (1978). Hypotensive action of beta-blocking drugs injected into the cerebral ventricle of the rat. *Arch. Int. Pharmacodyn.*, **232**, 158-165.

The relationship between *in vivo* pressor responses to alpha adrenoceptor agonists and *in vitro* receptor binding after phenoxybenzamine

C.A. HAMILTON, J.L. REID & D.J. SUMNER
Departments of Materia Medica and Nuclear Medicine, University of Glasgow, Great Britain

Decreases in α adrenoceptor number which may be related to altered *in vivo* responses have been observed under a variety of conditions (Williams & Lefkowitz, 1977; 1979; Elliot, Peters & Grahame-Smith, 1980).

We have compared the changes observed *in vitro* in radioligand binding and *in vivo* in responses to α adrenoceptor agonists in male White New Zealand

THE EFFECTS OF CENTRALLY-ADMINISTERED ADRENALINE ON RAT BLOOD PRESSURE - MODIFICATION BY SELECTIVE β -ADRENORECEPTOR BLOCKADE

D.P. Clough*, A.J. Draper, P.H. Redfern, R.D. Sheridan. Pharmacology Group, School of Pharmacy & Pharmacology, University of Bath, Claverton Down, Bath, and *Bioscience Department II, I.C.I. Ltd., Pharmaceuticals Division, Alderley Park, Cheshire.

Drugs like propranolol, whose major pharmacological property is a competitive blockade of β -adrenoreceptors, play an important part in the management of essential hypertension, although the precise mechanism, or mechanisms by which they lower blood pressure remains obscure. In the course of investigating the possibility of a centrally-mediated component in the antihypertensive process, we have recently shown (Clough et al 1981) that when introduced into the lateral cerebral ventricles (i.c.v.) of the anaesthetised rat, doses of adrenaline that are ineffective alone produce a marked pressor response in the presence of central β -receptor blockade. These results suggest that adrenaline exerts within the brain both an excitatory and an inhibitory effect on blood pressure, and that the inhibitory effect is mediated via β -receptors; the experiments reported here explore further the central interaction between β -receptor blocking drugs and adrenaline.

Male Wistar rats (Alderley Park strain) weighing 220-270g were anaesthetised with thiobutobarbitone sodium ('Inactin', BYK Ltd.) 150mg kg⁻¹ i.p. Blood pressure was recorded from a carotid artery and heart rate was derived from the blood pressure pulse. All drugs were injected through a 30 gauge stainless steel cannula inserted by means of a David Kopf stereotaxic instrument into the left lateral cerebral ventricle (co-ordinates A3.29, L4.4, H-0.4mm, König & Klippel); they were dissolved in artificial C.S.F. and injected at a rate of 2 μ l min⁻¹ in volumes not exceeding 10 μ l. Figure 1 illustrates the effect on mean arterial pressure (MAP) of 20 μ g adrenaline i.c.v., alone and 10 minutes after the i.c.v. injection of propranolol, atenolol and ICI 118551, 30 μ g. Propranolol is considered to be equipotent on β_1 and β_2 receptors, while atenolol has some selectivity for β_1 receptors (Ablad et al 1973). On the other hand ICI 118551 has a selective action on β_2 receptors (O'Donnell & Wanstall 1980). These results therefore suggest that the central inhibitory effect of adrenaline on cardiovascular responses may be mediated by adrenoreceptors of the β_2 type.

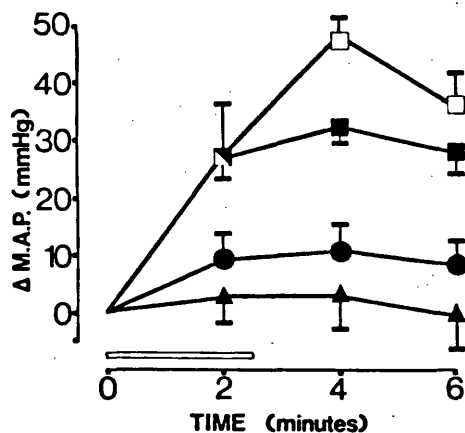

Figure 1.

Effect of 20 μ g i.c.v. adrenaline on blood pressure. Pretreatment with artificial CSF - \blacktriangle (n=7); 30 μ g ICI 118551 HCl - \square (n=6); 30 μ g propranolol HCl - \blacksquare (n=7); 30 μ g atenolol - \bullet (n=6). Means \pm SEM. Horizontal bar = adrenaline injection.

The support of I.C.I. Ltd and S.R.C. in the form of a CASE studentship to RDS is gratefully acknowledged.

Ablad, B. et al (1973) Life Sci 12: 107-119.

Clough, D.P. et al (1981) Br. J. Pharmac., in press.

O'Donnell, S.R. & Wanstall, J.C. (1980) Life Sci 27: 671-677.

0022-3573/81/120041 P-01\$02.50/0

© 1981 J. Pharm. Pharmacol.

EFFECTS OF CENTRALLY INJECTED β -BLOCKERS ON THE PRESSOR RESPONSES TO ELECTRICAL STIMULATION IN THE POSTERIOR HYPOTHALAMUS AND MEDIAL RAPHE NUCLEUS OF THE ANAESTHETISED RAT

D.P. Clough*, A.J. Draper, P.H. Redfern, R.D. Sheridan, Pharmacology Group, School of Pharmacy & Pharmacology, University of Bath, Claverton Down, Bath, and *Bioscience Department II, ICI Ltd., Pharmaceuticals, Divn., Alderley Park, Cheshire.

Although β -blockers have been used for many years to control high blood pressure, their mechanism of action remains unknown. One possibility is that at least part of their antihypertensive activity is mediated via the central nervous system. For example, Lewis & Haeusler (1975), using conscious rabbits, observed a decrease in preganglionic sympathetic nerve activity and blood pressure following intravenous propranolol. However, in the rat, experiments in which β -blockers have been injected into the cerebral ventricles (i.c.v.) have yielded conflicting results with respect to blood pressure modulation. It has long been recognised that the hypothalamus is intimately involved in the autonomic control of the circulation and that electrical stimulation in the posterior hypothalamus (PH) can evoke elevations of blood pressure (Folkow & Rubinstein 1966). More recently, Smits et al (1978), using anaesthetised rats, obtained pressor responses following stimulation in the medial raphe nucleus (MRN). In the present investigation we have looked at the effects of i.c.v. β -blockers on the pressor responses produced by electrical stimulation in these two brain areas.

Male Wistar rats (Alderley Park strain) weighing 220-270g were prepared as described previously (Clough et al 1981). Monopolar electrodes fashioned from electrolytically sharpened and insulated stainless steel wire, had exposed tip lengths of 20-40 μ m. Negative-going square-wave pulses, delivered via a constant current device, were applied to the stimulating electrode, the indifferent electrode being secured to the subcutaneous tissue exposed by the scalp incision. Stimulus parameters were—pulse width 2msec; current 200 μ A; train duration 5 seconds; frequency 20-80Hz. Coordinates of the PH and MRN were A3.5, L1.0, H-2.5mm and A0.35, L0, H-2.5mm, respectively (König & Klippel). Stimulation at both sites induced frequency-dependent increases in systolic blood pressure - Table 1.

Table 1. Pressor responses to electrical stimulation (mean \pm SEM).

AREA	SYSTOLIC PRESSOR RESPONSE (mmHg)				
	Frequency (Hz)				
	20	40	60	80	
Posterior hypothalamus	3 \pm 1	34 \pm 4	66 \pm 5	—	(n = 5)
Medial raphe nucleus	—	16 \pm 2	42 \pm 2	57 \pm 4	(n = 15)

Propranolol HCl, 100 μ g i.c.v., failed to affect the pressor responses to PH stimulation, while 50 μ g failed to modify the responses to MRN stimulation. Atenolol, 50 μ g i.c.v., did not alter the responses to MRN stimulation except at the highest frequency (80Hz), where the response was significantly increased (paired t-test; $P < 0.05$). These results suggest that any β -receptor capable of modifying pressor responses evoked in this way are not accessible to drugs injected i.c.v.

The support of ICI Ltd., and S.R.C in the form of a CASE studentship to RDS is gratefully acknowledged.

Clough, D.P. et al (1981) Br. J. Pharmac. In press.

Folkow, B. & Rubinstein, E.H. (1966) Acta physiol. scand. 68: 48-57.

Lewis, P.J. & Haeusler, G. (1975) Nature 256: 440.

Smits, J.F.M. et al (1978) Life Sci. 23: 173-178.

0022-3573/81/120091P-01\$02.50/0

© 1981 J. Pharm. Pharmacol.

A RELATIVELY INEXPENSIVE COMBINED STIMULUS ISOLATION/CONSTANT CURRENT DEVICE

R.D.Sheridan (Introduced by P.H.Redfern), Pharmacology Group, School of Pharmacy and Pharmacology, University of Bath, Claverton Down, BATH BA2 7AY.

The circuit described enables the construction of a combined stimulus isolation (SI) / constant current (CC) device at a small fraction of the cost of comparable commercial units. The complete circuit is shown in Figure 1 and the components in Table 1. SI is achieved by IC1, wherein the stimulus pulse is converted to light. R1 serves to limit the current through IC1 and is based on a 9 Volt input from a dry cell battery. The isolated side of IC1 is connected as a photodiode and light falling on this causes a potential difference (pd) of about 1.2 Volts to appear across RV1. The whole or part of this pd is tapped at pin 3 of IC2, which is a general purpose operational amplifier connected as a voltage follower. Its purpose is to bias TR1 variably, and to maintain a pd across R2 equal to that seen at pin 3 of IC2. If this pd is 0.6 Volt, for example, and R2 is 1.2 k ohm, then a current of 0.5 mA will flow through R2. If a voltage, V_s , is now applied to the collector of TR1, then a current will start to flow through TR1 and R2 towards the 0 Volt line. In so doing, however, the pd across R2 is raised from its initial value (set by RV1) and this in turn causes the output of IC2 to fall. Thus, the base bias of TR1 is reduced and current flow through the transistor is decreased until the pd across R2 is returned to that value seen by pin 3 of IC2. At this point the current in the collector circuit of TR1 is the same as that in R2. This holds true for increasing values of resistance in the collector circuit provided that V_s is sufficiently high. In practice we have found 60 Volts to be suitable for our purposes.

To set up, set the stimulator voltage dial to 10 Volts and, with PB1 closed and RV1 wiper set to maximum tapped voltage, increase the stimulator output until a current of 1 mA is seen by a milliammeter placed in series between V_s and the TR1 collector. This stimulator voltage is utilised throughout subsequent use of the SI/CC unit. Currents greater than 1 mA may be obtained by reducing the value of R2. Stimulating current is adjusted by means of RV1.

Figure 1. SI/CC unit circuit. IC pin numbers are shown

Table 1. Components

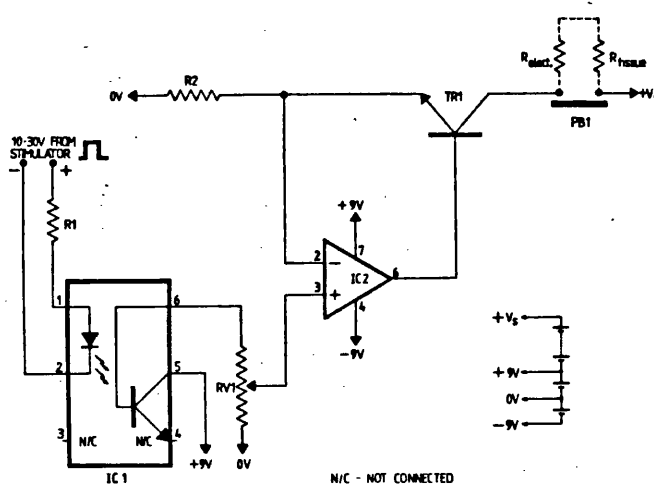

R1	400 ohm
R2	1 - 1.5 k ohm
RV1	Linear 50 k ohm
TR1	BFX 85
IC1	OPTO-ISOLATOR *
IC2	μ A 741

* This component (order code WL35Q) available from Maplin Electronic Supplies, London, England. (Tel: 01 - 748 0926).