

phys. stat. sol. (a) **98**, 107 (1986)

Subject classification: 61.55; 64.75; 71.25; S1.2

*Institute for Solid State Physics, Eötvös University Budapest¹⁾ (a)
and Department of Solid State Physics, Lomonosov State University Moscow (b)*

Study of Crystal and Electronic Structure of Ti-Cr Alloys during Decomposition of β -Solid Solution

By

L. KERTÉSZ (a), A. SZÁSZ (a), M. I. ZAKHAROVA (b), and A. G. KHUNDZHUA (b)

Changes in the crystal structure of Ti alloys, containing 23.5 and 17 at% Cr are studied during the decomposition of β -solid solution by means of X-ray and electron diffraction (XRD and TEM) methods. Parallel to these tests, the electronic structure and chemical bonds of the alloys are investigated by soft X-ray emission (SXES) as well as by soft X-ray fluorescent (SXFS) methods. Attention is drawn to the structures of the metastable as well as equilibrium α and TiCr_2 phases.

Änderungen in der Kristallstruktur von Ti-Legierungen mit 23,5 und 17 At% Cr, werden während des Zerfalls der β -Festkörperlösung mittels Röntgen- und Elektronenbeugungs(XRD und TEM)-Methoden untersucht und parallel dazu die Elektronenstruktur und chemischen Bindungen der Legierungen, sowohl mittels weicher Röntgenemission (SXES) als auch weicher Röntgenfluoreszenz (SXFS). Insbesondere die Strukturen der metastabilen sowie der α - und TiCr_2 -Gleichgewichtsphasen werden untersucht.

1. Introduction

In the binary Ti-Cr alloy in the high temperature region, a β -solid solution having a disordered b.c.c. structure (see Fig. 1a) can be frozen in partly or totally in a metastable state by quenching.

The decomposition of this metastable β -solid solution depending on the actual heat treatments and concentrations can happen in three different ways,



where β_0 is a metastable β -solid solution enriched in the Cr component by diffusion.

The decomposition shown in (3) can occur also through different intermediate stages and the formation of the metastable ω -phase from the β -solid solution [1, 2],

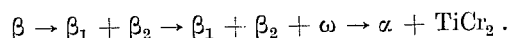

During the formation of a metastable ω -phase by decomposition of β -phases in many titanium-based alloys a hexagonal ω -phase was observed with three atoms in the elementary cell and $c/a = 0.612$ [1].

In the present paper the phase transformation of Ti-17 at% Cr and Ti-23.5 at% Cr is considered.

¹⁾ Muzeum krt. 6-8, H-1088 Budapest VIII, Hungary.

2. Experimental

The Ti-Cr prealloys were made in an arc furnace under protective argon atmosphere and were six times remelted. The purities of the starting components were: Ti 99.9 at% and Cr 99.5 at%.

Stabilizing heat treatments were carried out before ageing of the Ti-17 at% Cr and Ti-23.5 at% Cr alloys, i.e. they were heated at 1100 °C for 24 h and quenched into oil for stabilization of the b.c.c. β -matrix at room temperature, in vacuum at a pressure of 10^{-3} Pa.

The precipitation process of the TiCr_2 intermetallic compound from the β -phase of the Ti-23.5 at% Cr alloy was studied, after quenching and annealing at 850 and 750 °C, respectively.

The $\beta \rightarrow \alpha + \text{TiCr}_2$ decomposition was investigated after ageing at temperatures of 350 and 550 °C.

The measurements were carried out by using commercial equipments USR-40, TESLA-BS613, and RSM-500 for the XRD, TEM, and SXES methods, respectively. The XRD investigations were performed on a stationary single crystal and also on polycrystals, the thin foil-type sample for the selected-area electron diffraction method was prepared by electropolishing.

During the initial states of ageing the precipitation of low amounts of very fine crystallites of a metastable ω -phase was observed. In the second stage of ageing, the α -crystal also appears. The XRD reflections of ω - and α -crystals in the first stage of the ageing process are very weak, consequently the identification of ω - and α -phases by the Debye method is difficult, therefore, the single crystal method was used. The crystals were oriented with $\langle 110 \rangle$ or $\langle 100 \rangle$ direction parallel to the X-ray beam after each ageing process. The X-ray diffraction patterns of single crystals were compared

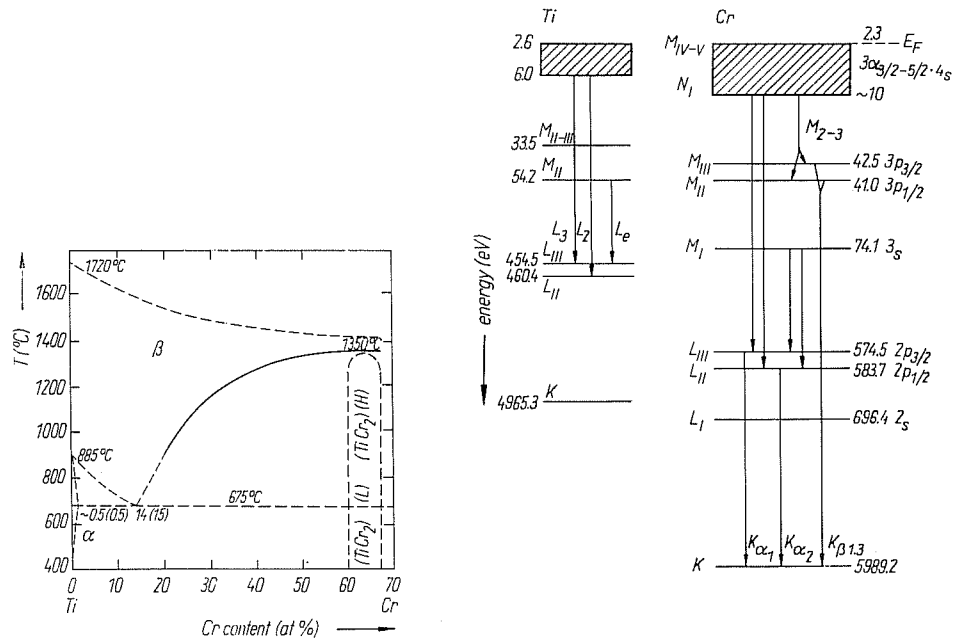

Fig. 1. a) Phase diagram of Ti-Cr binary alloy and b) schematic energy level diagrams of Ti and Cr

with calculated positions of ω and α reflections. The method for calculating the diffraction pattern of a single crystal was described in [3].

The SXES measurements were performed by using the $M_{2,3}$ and $L_{2,3}$ spectra of Cr and Ti, respectively. For checking of the intensities and the energy scale, the internal lines (L_1) and for the monitoring of the surface contaminations the oxygen emission (K_α) peak were also measured. The schematic level scheme with the measured transitions is shown on Fig. 1 b.

The reference measurements were carried out on pure Ti and Cr samples with 99.9 at% and 99.5 at% purity, respectively.

3. Experimental Results

3.1 Ti-23.5 at% Cr alloy

On the diffraction pattern of polycrystals of Ti-23.5 at% Cr after quenching from 1100 °C only the b.c.c. lines of the β -solid solution are observed with the lattice parameter $a = 0.318$ nm (Fig. 2). On the diffraction pattern of the stationary crystal after the quenching besides the reflection of the β -solid solution there are diffuse reflections of the ω -phase. The crystallite size is 2.5 nm as inferred from TEM.

The process of transformation of $\beta \rightarrow \alpha + \text{TiCr}_2$ after ageing at 350 and 550 °C was also studied. On the diffraction patterns of a stationary crystal reflections of the ω -phase appeared after 10 min ageing at 350 °C. These lines are however not the only ones, which appeared. The extra lines are very similar to those (Fig. 3a) discovered by Prasetto [4] in the Cu-Zn and some other alloys [5] too; this new phase was named as ω_2 . The positions of the reflections of the ω_2 -phase were calculated on the diffraction pattern of the single crystal.

The comparison of experimental and calculated diffraction patterns has indicated a precipitation of the ω -phase in the Ti-23.5 at% Cr alloy. This new phase has six

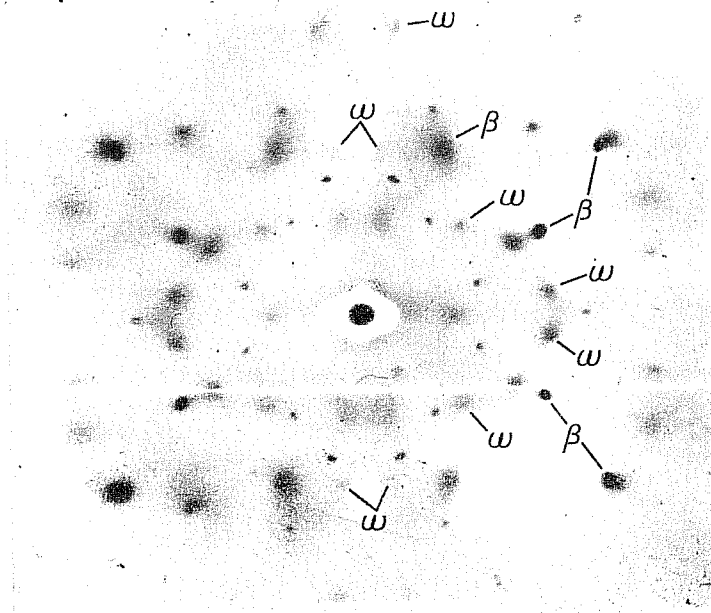

Fig. 2. Diffraction pattern of polycrystalline Ti-23.5 at% Cr alloy after quenching from 1100 °C

atoms in its elementary cell. The electron diffraction patterns confirm an ordered CsCl-type structure of β -solid solution and ω_2 -phase.

After 30 min ageing at 350 °C the crystal reflections of TiCr_2 appeared in the diffraction patterns (Fig. 3 b).

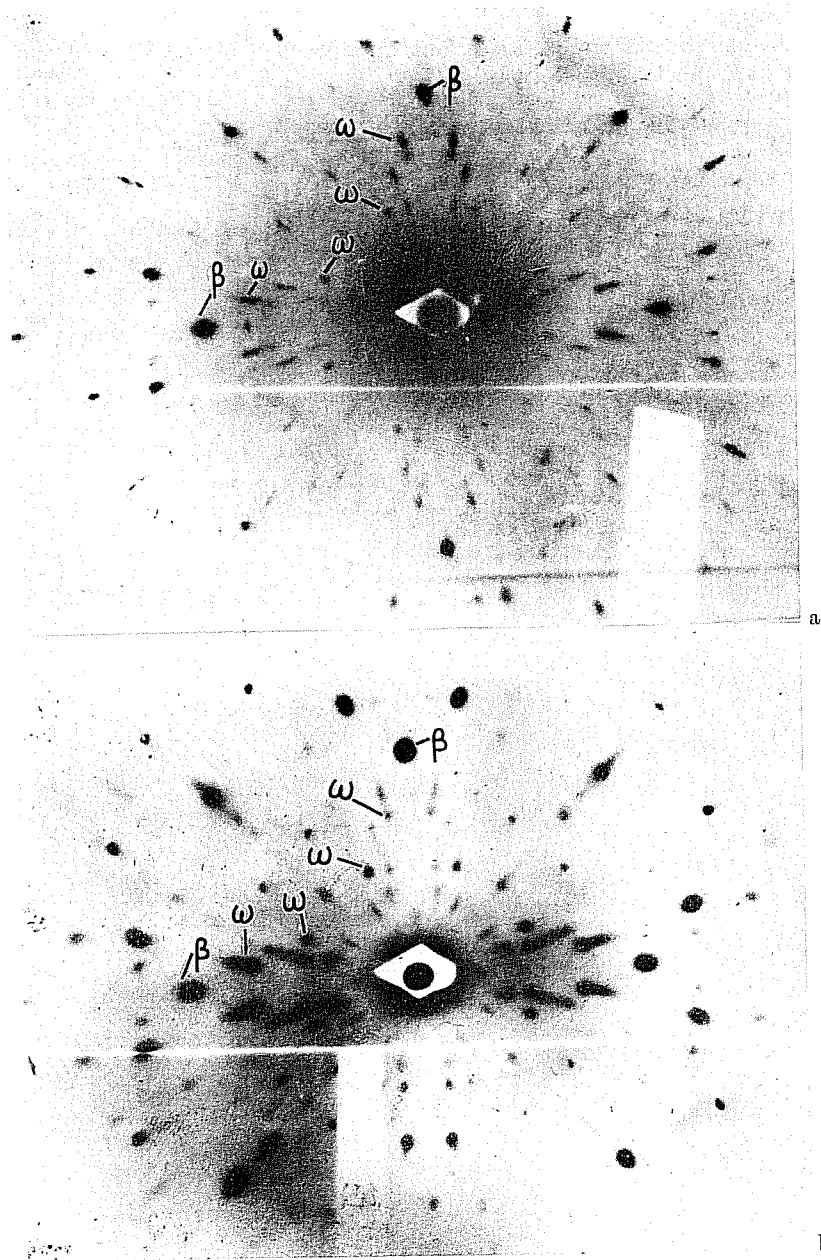

Fig. 3. Diffraction pattern of Ti-23.5 at% Cr alloy after ageing at 350 °C a) for 10 and b) for 30 min

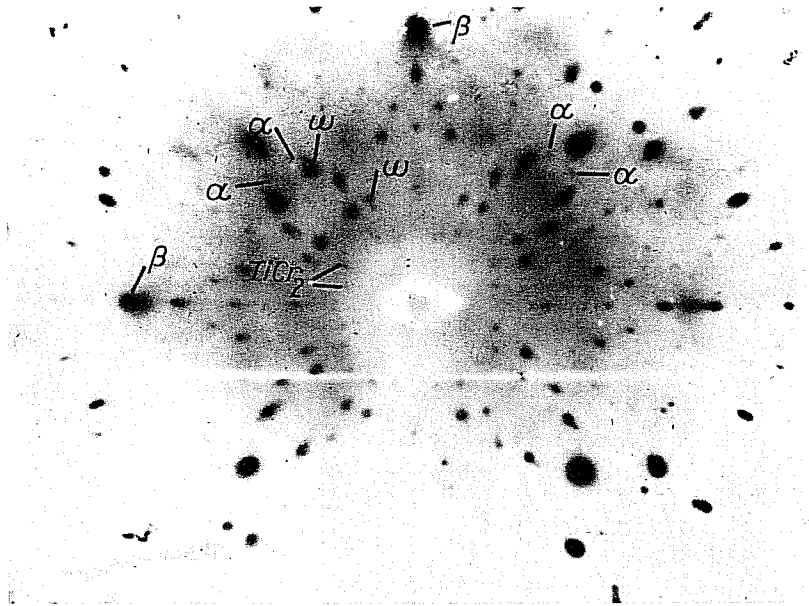

Fig. 4. Single crystal reflections of Ti-23.5 at% Cr alloy after ageing at 550 °C for 3.5 h

Ageing of the quenched Ti-23.5 at% Cr single crystals at 550 °C for 3.5 h leads to the appearance of single crystal reflections of β -, ω_2 -, α -, and TiCr_2 -phases (Fig. 4). The β -solid solution and ω_2 -phase have an ordered arrangement of atoms. The increase of ageing time to 16 h at the temperature of 550 °C does not change the diffraction pattern. Consequently, the $\beta \rightarrow \alpha + \text{TiCr}_2$ transformation at 550 °C occurs very slowly.

In the case of the Ti-Cr systems containing 15 to 60% Cr above 670 °C the $\alpha + \text{TiCr}_2$ phases are found. The investigations of the precipitation process of TiCr_2 from the β -solid solution at 850 °C show that after heating for 20 h the reflections of β -solid solution and TiCr_2 appear on the diffraction pattern of the crystal.

The increase of ageing time at 550 °C does not cause any changes in the diffraction patterns. Ageing of the alloy Ti-23.5 at% Cr at 750 °C for 17 h also brings about a $\beta + \text{TiCr}_2$ structure.

The microphotography of the alloy of Ti-23.5 at% Cr after ageing at 850 °C for 20 h shows that the grains of TiCr_2 have an oblong shape of a length of 0.02 to 0.05 μm (Fig. 5 a). The corresponding diffraction pattern is shown on Fig. 5 b.

The SXES L_3 -spectrum of titanium is much more sensitive for phase changes than that of chromium, as can be seen on Fig. 6. Chemical shifts and peak shape changes are both observable. The internal L_1 peaks (Fig. 7 a and Fig. 7 b) do not show any remarkable changes except on the CrL_1 peak in the stable $\alpha + \beta$ states.

3.2 Ti-17 at% Cr alloy

After quenching the alloy from 1100 °C, it consists of only one phase, the β -solid solution. On the X-ray and electron diffraction patterns of stationary single crystal and β -solid solution besides β -reflections some diffuse effects are present which indicate the displacement of atoms in the $\langle 111 \rangle$ direction.

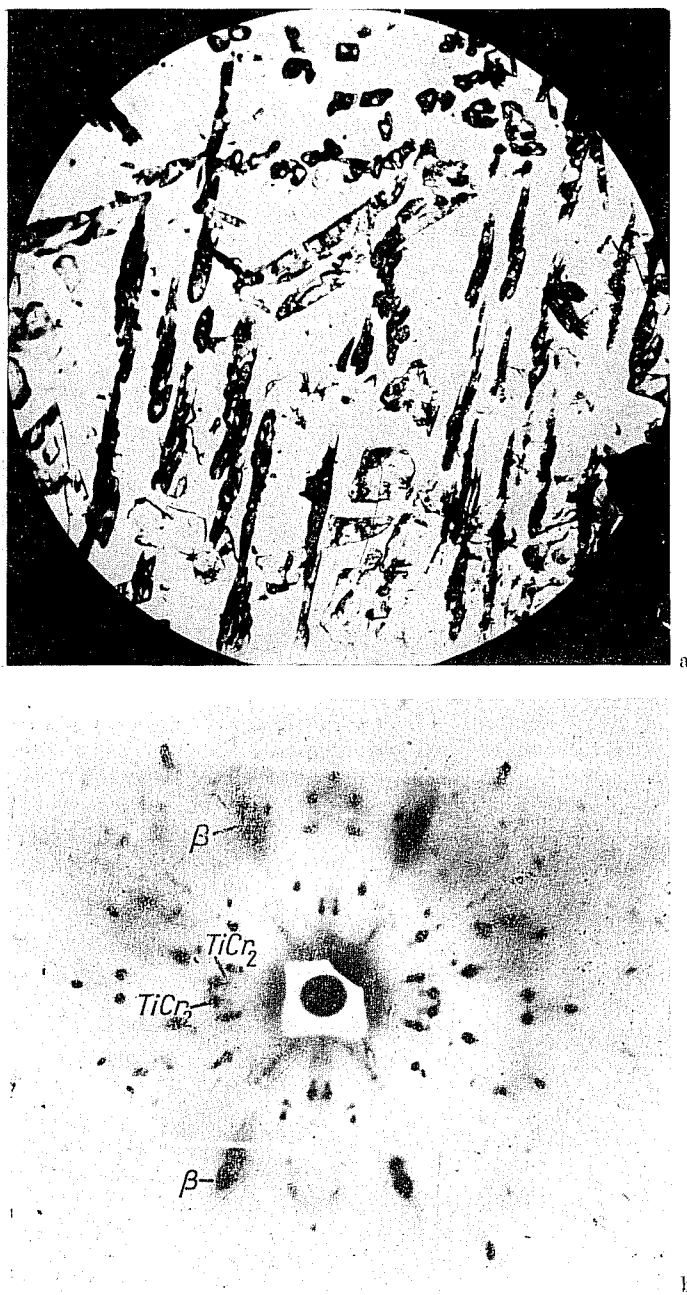

Fig. 5. a) Microphotograph (magnification: $\times 440$) and b) diffraction pattern of Ti-23.5 at% Cr after ageing at 850 °C for 20 h

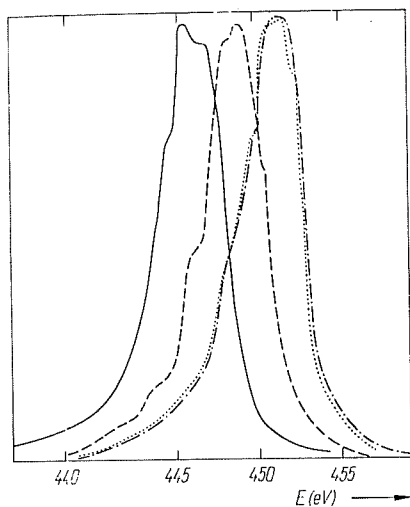
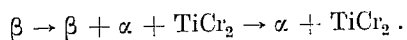

Fig. 6. Ti L_3 SXES-spectra of Ti-23.5 at% Cr alloy. — $\alpha + \beta$, --- $\alpha + \omega$, - · - β , · · · · pure Ti

The β -solid solution in the process of ageing at 550 °C is transformed in the following way:



After ageing at 550 °C for 15 h polycrystals of α and TiCr_2 can be observed on the diffraction patterns.

Comparing the SXES Ti L_3 -spectra in the Ti-23.5 at% Cr and Ti-17 at% Cr alloys some changes of the intensity ratios of the subpeaks can be observed (Fig. 8). The

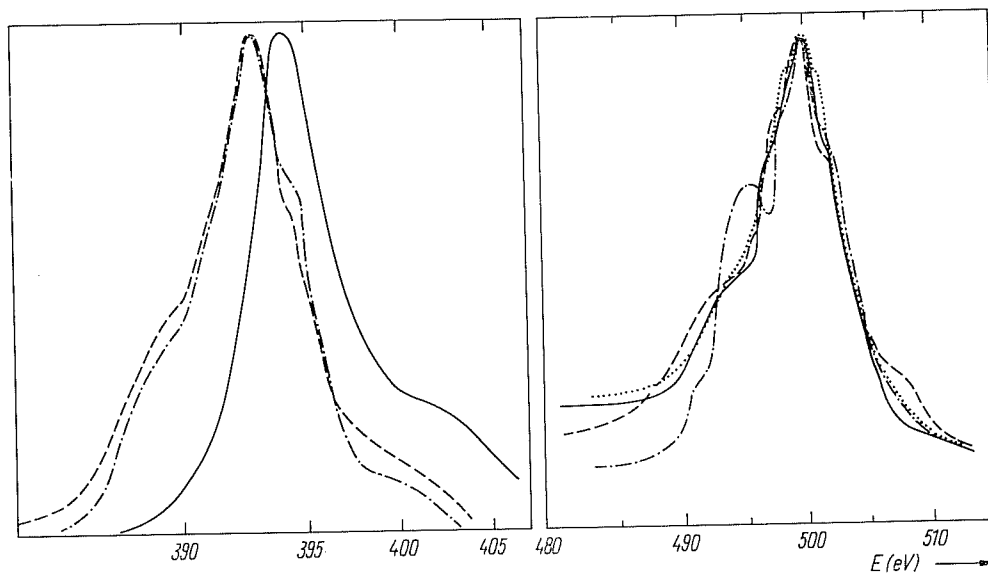

Fig. 7. a) Ti L_1 -spectra of Ti-23.5 at% Cr alloy compared to pure Ti. — pure Ti, --- $\alpha + \beta$, - · - $\beta + \omega$. b) Cr L_1 -spectra of Ti-23.5 at% Cr alloy compared to pure Cr. — pure Cr, --- $\beta + \omega$, · · · · β , - · - $\alpha + \beta$

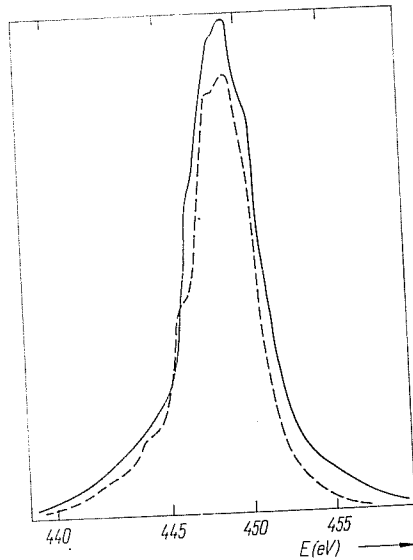

Fig. 8

Fig. 8. Comparison of the Ti-Cr alloys containing 17 at% (—) and 23.5 at% Cr (---) ($\text{Ti L}_{2,3}$ -spectra, $\beta + \omega$ phase)

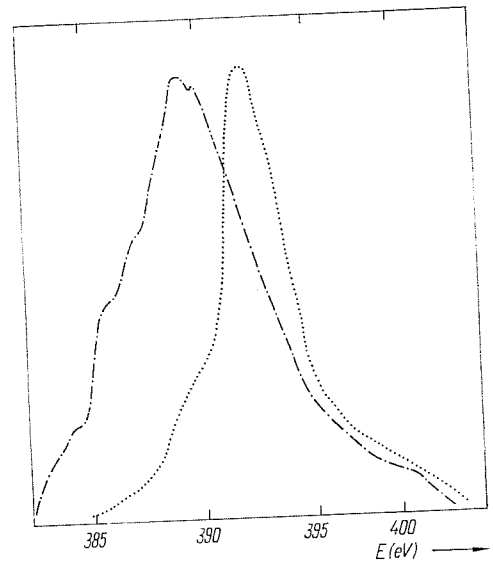

Fig. 9

Fig. 9. Chemical shift of L-spectra of the Ti-17 at% Cr alloy. $\alpha + \beta$, -.- $\beta + \omega$

chemical shift of L-spectra is considerably larger for the 17 at% Cr alloy composition (Fig. 9).

Concerning the changes of the electronic structure, depending on the decomposition of the β -solid solution measured by SXES, the following can be observed:

- (i) The decomposition process obtained by TEM has some fine steps, without any observable effect on the electronic density of states within our experimental resolution.
- (ii) The solubility of the chromium component in the α -phase is very small (≈ 1 to 2 at%), so the chromium atoms remain in the β -phase at the decomposition, transforming directly to the equilibrium TiCr_2 compound. During this transformation the

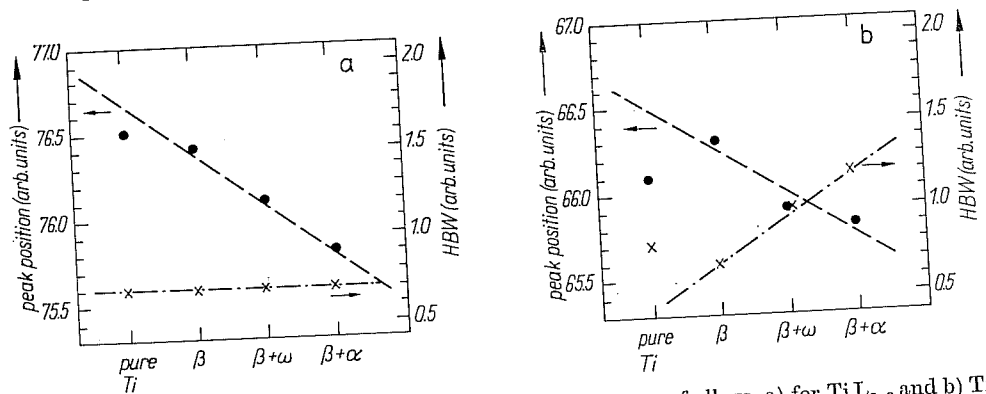

Fig. 10. The summary of SXES data depending on the phases of alloys. a) for $\text{Ti L}_{2,3}$ and b) Ti L_1 for Ti-23.5 at% Cr

Cr $L_{2,3}$ emission line does not change, so the local electronic structure around the chromium atoms is unchanged for $\beta \rightarrow \alpha + \text{TiCr}_2$ decomposition, showing a similar short-range order in the first coordination sphere of Cr.

(iii) The first coordination sphere of titanium atoms in the β -phase is considerably different from the α -phase one, so that at the $\beta \rightarrow \alpha + \text{TiCr}_2$ transition electronic structure changes are observable. The peak shift and half-band width of Ti $L_{2,3}$ and L_1 lines are summarised on Fig. 10. The same slopes of the peak position dependence for the different states of the alloy suggest the moving of only the L_{II} and L_{III} internal levels. The unchanged HBV at the $L_{2,3}$ line indicates the unperturbed conduction states. The chemical bonds are located first of all at the M_{II} and M_{III} levels in this transformation processes.

(iv) The decomposition of the β -solid solution to the stable $\alpha + \text{TiCr}_2$ phases occurs at a higher rate in Ti-17 at% Cr than in Ti-23.5 at% Cr alloys at 550 °C.

Acknowledgements

The authors are very grateful to J. Kojnok for the help in SXES measurements, and to Ministries of Education of Hungary and USSR for financial support.

References

- [1] M. K. McQUILLAM, *Metals Rev.* 8, 41 (1963).
- [2] V. CHANDRASEKARAN, R. TAGGART, and D. H. POLONIS, *Metallography* 6, 313 (1973).
- [3] N. I. ZAKHAROVA, A. V. SOROKHIN, and A. G. KHUNDZHUA, *Vestnik Moskovskogo Univ. Ser. Fiz. Abstr.* 25, 80 (1984).
- [4] A. PRASETTO, F. REYNAUD, and H. WARLIMONT, *Acta metall.* 24, 1009 (1976).
- [5] M. I. ZAKHAROVA and A. A. AMINOV, *Fiz. Metallov i Metallovedenie* 51, 332 (1981).

(Received June 18, 1986)