



Durham E-Theses

A reassessment of the early medieval stone crosses and related sculpture of offaly, Kilkenny and Tipperary

Edwards, Nancy

How to cite:

Edwards, Nancy (1982) *A reassessment of the early medieval stone crosses and related sculpture of offaly, Kilkenny and Tipperary*, Durham theses, Durham University. Available at Durham E-Theses Online: <http://etheses.dur.ac.uk/7418/>

Use policy

The full-text may be used and/or reproduced, and given to third parties in any format or medium, without prior permission or charge, for personal research or study, educational, or not-for-profit purposes provided that:

- a full bibliographic reference is made to the original source
- a [link](#) is made to the metadata record in Durham E-Theses
- the full-text is not changed in any way

The full-text must not be sold in any format or medium without the formal permission of the copyright holders.

Please consult the [full Durham E-Theses policy](#) for further details.

Academic Support Office, Durham University, University Office, Old Elvet, Durham DH1 3HP
e-mail: e-theses.admin@dur.ac.uk Tel: +44 0191 334 6107
<http://etheses.dur.ac.uk>



a
reassessment
of the early
medieval stone
crosses and
related sculpture
of offaly
kilkenny and
tipperary

nancy edwards

Abstract

This study is concerned with the Early Medieval freestanding stone crosses and related sculpture of three Irish counties, Offaly, Kilkenny and Tipperary. These monuments are recorded both descriptively and photographically and particular emphasis has been placed on a detailed analysis of the Hiberno-Saxon abstract ornament, the patterns used and, where possible, the way in which they were constructed.

The discussion begins with a survey of the origins and morphology of the freestanding cross in Ireland examining both archaeological and documentary evidence. The monuments are then divided into groups according to similarity. Each group is discussed, the form and layout of the monuments, their abstract and iconographical ornament, and these are compared with sculpture elsewhere, objects in other media, and the origins of the various motives are also considered where appropriate.

Chronologically, three main groups emerge. In the late eighth and early ninth centuries there are several local groups making use of a wide variety of abstract ornament, often influenced by metalwork and manuscript motives, but with little figural iconography. Close links have also been noted with sculpture in Scotland. During the ninth century the abstract ornament gives way to an increasing use of Scriptural iconography, probably popularised by contact with Carolingian Europe, which may first be detected on some 'Transitional' monuments. Finally, the figural iconography predominates, giving rise to the distinctive 'Scripture' crosses of the late ninth and tenth centuries.

A Reassessment of the Early Medieval
Stone Crosses and Related Sculpture
of Offaly, Kilkenny and Tipperary

by

Nancy Edwards

Vol. I

Thesis submitted for the degree of Doctor of Philosophy at the
University of Durham, 1982.

Archaeology Department

The copyright of this thesis rests with the author.
No quotation from it should be published without
his prior written consent and information derived
from it should be acknowledged.



22 MAY 1984

Declaration

I hereby declare that none of the material in this thesis has previously been submitted for a degree in this or any other university.

Copyright

The copyright of this thesis rests with the author. No quotations from it should be published without her prior written consent, and information derived from it should be acknowledged.

CONTENTS

	<u>Page</u>
Vol. I.	
List of Maps and Figures	
Acknowledgements	
CH. I. <u>INTRODUCTION</u>	1
CH. II. <u>INTRODUCTION TO THE ORNAMENT</u>	6
1. Interlace	7
2. Spirals	10
3. Frets	13
4. Step and Chequer Board Patterns	15
5. Zoomorphic and Anthropomorphic Patterns	16
CH. III. <u>THE ORIGINS AND MORPHOLOGY OF THE FREESTANDING CROSS IN IRELAND</u>	21
1. The Prehistoric Period	21
2. The Beginnings of Early Christian Sculpture in Ireland	22
3. The Development of the Freestanding Cross in Ireland	29
4. Origins of the Wheelhead	34
5. Origins of the Capstone	37
6. The Purpose of the Crosses	38
CH. IV. <u>THE CLONMACNOISE GROUP</u>	45
1. The Form and Layout of the Monuments	46
2. Stone	49
3. The Ornament	50
a) Interlace	
Bealin (51), Clonmacnoise I (54), Banagher (55), Clonmacnoise II and III (56), Clonmacnoise IV (57), Conclusions (60).	
b) Zoomorphic Ornament	62
Confronted Dragonlike Beasts with interlocking beaks (62), Serpents with Interlaced Bodies (64), Birds and Animals with Spiralled Bodies (65), Interlace Panels with Bird's Head Terminals (68), Anthropomorphic Motives (68), Inhabited Vine- scroll (72), Conclusions (75).	
c) Spirals	75
Bealin, Banagher and Clonmacnoise II (76), Clonmacnoise IV (77), Conclusions (78).	
d) Step Patterns	78
e) Fret Patterns	79

4.	Beasts	81
	a) Lions and Griffins	81
	b) Fantastic Beasts	84
5.	Figural Iconography	84
	a) Horsemen and Hunting Scenes	84
	b) Scriptural Iconography	86
	The Crucifixion (86), The Fall (88),	
	Conclusions (88).	
6.	The Bealin Inscription	88
7.	The Dating of the Monuments	89
CH. V.	<u>THE OSSORY GROUP</u>	95
1.	The Form and Layout of the Monuments	96
	The Mouldings (97), Bosses (98), The Form of	
	Kilkieran I (99)	
2.	The Ornament	100
	a) Spirals	100
	Ahenny I (100), Ahenny II (102), Kilkieran II	
	(103), Lorrha I (103), Kilkieran I (103),	
	Conclusions (104).	
	b) Interlace	104
	Ahenny I (106), Ahenny II (106), Kilkieran II	
	(107), Lorrha I, Lorrha II and Seir Kieran (110),	
	Conclusions (110).	
	c) Fret Patterns and Related Ornament	112
	d) Step Patterns and Related Designs	113
	e) Zoomorphic Ornament	114
3.	Figural Panels	116
	a) Ahenny I	116
	b) The Help of God Symbolic Cycle	121
	c) Hunting Scenes and Related Iconography	123
4.	The Dating of the Monuments	128
CH. VI	<u>KILREE AND KILLAMERY</u>	133
1.	The Form and Layout of the Monuments	133
2.	The Ornament	135
	a) Fret Patterns and Related Ornament	135
	b) Step Patterns and Related Ornament	137
	c) Zoomorphic Ornament	138
	Dragonesque Motives (138), The Displayed Beast	
	(140).	
	d) Interlace	141
	e) Spirals	144
3.	Figural Panels	145
	a) Scriptural Iconography	146

	The Crucifixion (146), Daniel in the Lions' Den (147), Jacob and the Angel (149), The David Cycle (149).	
	b) Religious Processions and Hunting Scenes	152
4.	Fantastic Beasts	153
5.	The Killamery Inscription	153
6.	The Dating of the Monuments	153
CH. VII	<u>THE TYBROUGHNEY AND ROSCREA SHAFTS</u>	157
1.	The Form and Layout of the Monuments	158
2.	The Ornament	159
	a) Beasts	159
	b) Spirals	165
3.	The Dating of the Monuments	166
CH. VIII	<u>KINNITTY, TIHILLY AND DRUMCULLIN</u>	169
1.	The Form and Layout of the Monuments	170
2.	The Ornament	171
	a) Interlace	172
	b) Zoomorphic Ornament	174
	Processions of Quadrupeds with Spiralled Bodies (174), Confronted Quadrupeds (175), Confronted Birds with Interlaced Necks (175), Serpentine Beasts with Interlace Bodies (176), Anthropomorphic Motives (177).	
	c) Spirals	177
	d) Fret Patterns	178
3.	Scriptural Iconography	179
	a) The Crucifixion	180
	b) The Fall	181
	c) The David Cycle	182
4.	The Inscription on Kinnitty I	182
5.	The Dating of the Monuments	183
CH. IX	<u>GRANITE CROSSES FROM THE BARROW VALLEY</u>	186
1.	The Form and Layout of the Monuments	187
2.	Figural Iconography	188
	a) The Crucifixion	188
	b) The Twelve Apostles	190
	c) The Massacre of the Innocents	192
	d) The Fall	193
	e) The Sacrifice of Isaac	193
	f) David Playing the Harp	194
	g) Miscellaneous Iconography	194
	h) Conclusions	194

3.	Abstract Ornament	195
	a) Spirals	195
	b) Interlace	196
	c) Frets	196
	d) Conclusion	197
4.	Conclusions	197
CH. X.	<u>CLONMACNOISE V AND DURROW I</u>	201
1.	The Form of the Monuments	202
2.	The Layout of the Monuments	204
3.	The Figural Panels	205
	a) The Passion Cycle and Related Iconography (205), The Entry into Jerusalem (206), The Arrest of Christ and Related Scenes (207), The Denial of Peter (209), Pilate Washing his Hands (209), The Crucifixion (210), The Soldiers Guarding the Tomb and the Three Marys (214), Traditio Legis (216), Other Scenes (217), Conclusions (217).	
	b) The Last Judgement	218
	c) The David Cycle David and Musicians (222), David Breaking the Jaws of the Lion (226), David the Warrior (226), Goliath (227), Conclusions (227).	222
	d) The Evangelist Figures	228
	e) Old Testament Iconography The Fall, The Murder of Abel (230), The Sacrifice of Isaac (231), Jacob and the Angel (233).	230
	f) Manus Dei	233
	g) Other Figural Iconography Clonmacnoise V C 14 and 15 (234), Clonmacnoise V D 12 (235), Durrow I D 8 (236), Durrow I D 2 (237), Clonmacnoise V A 17 (237).	234
4.	Beasts	239
	a) Fantastic Beasts	239
	b) Cats	240
5.	The Ornament	240
	a) Spiral Ornament	241
	b) Interlace	242
	c) Zoomorphic Motives	243
	d) Anthropomorphic Motives	244
	e) Inhabited Vine=Scroll	245
	f) Frets	246
6.	The Inscriptions	246
7.	The Dating of the Monuments	249
	Addendum	256

CH. XI	<u>MISCELLANEOUS MONUMENTS</u>	257
	1. Clonmacnoise VI	257
	2. Dunnamaggan	259
	3. Durrow II and III	260
	a) Durrow I	260
	The Original Form of the Monument (260), The Decoration (261), Conclusions (262).	
	b) Durrow III	263
	4. Gallen Priory I and II	263
	a) Gallen Priory I	264
	The Form and Layout of the Monument (264), The Ornament (265), Conclusions (267).	
	b) Gallen Priory II	267
	5. Kilkieran IV	268
	6. Leggettsrath I and II	268
	7. Templeneiry	270
	a) Templeneiry I	270
	b) Templeneiry II	271
	c) Templeneiry III	272
	8. Thomastown	272
	9. Toureen Peakaun	273
CH. XII	<u>CONCLUSIONS</u>	275

APPENDICES

1.	The Circular Device in the Book of Mulling	281
2.	Some Aspects of Hiberno-Saxon Metalwork	283
	1. Vernacular Style Metalwork, some Problems and Techniques	283
	2. The Impact of the Vikings on Irish Metalworking	285
	3. Comparisons between the Abstract Ornament on Clonmacnoise I-IV, Banagher and Bealin and that on the Clonmacnoise Grave-Slabs.	287
	4. The Texts of the Prayers for Deliverance	288
	1. Féilire Óengusso, The Martyrology of Oengus	288
	2. Hymnus S. Colmani Mic Uí Clusaigh	292
	3. The Stowe Missal (R.I.A. Ms. D.II.3)	294

BIBLIOGRAPHY

295

CATALOGUE

323

PHOTOGRAPHS

LIST OF MAPS AND FIGURES

Maps

I	Ireland: Location of Offaly, Kilkenny and Tipperary	after 461
II	Early groups of sculpture, distribution	after 461
III	'Transitional' Crosses, distribution	after 461
IV	Location of 'Scripture' Crosses	after 461
V	Late and Miscellaneous Monuments, distribution	after 461

Figures

1.1-1.8	Interlace Patterns, catalogue	7-8
2.1-2.3	Spiral Patterns, catalogue	11-12
3	Construction of Spiral Patterns	12-13
4.1-4.3	Fret Patterns, catalogue	13-14
5	Example of construction of Fret Patterns: Kilree C 10	14-15
6.1-6.2	Step Patterns, catalogue	15-16
7	Table to compare the dimensions of the shafts amongst the Clonmacnoise Group	48
8	Table showing Interlace unit measures amongst the Clonmacnoise Group	50
9	Table showing repertoire of Interlace Ornament amongst the Clonmacnoise Group	51
10	Clonmacnoise I Face A, reconstruction of interlace	54-55
11	Clonmacnoise III Faces B and D, reconstruction of interlace	56-57
12	Clonmacnoise IV, interlace patterns on B 4 and D7	58-59
13	Confronted Dragonisque Beasts with interlocking beaks:- (1) Bealin A2 (2) Copenhagen Mount (after Wilson) (3) Benty Grange Mount (after Henry) (4) Book of Durrow (5) Durham A.II.17 (after Åberg) (6) Monkwearmouth porch (after Taylor and Taylor)	62-63
14	Serpents with interlaced bodies:- (1) Bealin D 5 (2) Meigle IV (3) and (4) Hunterston Brooch (after Stevenson)	64-65
15.1	Birds and Animals with Spiralled Bodies:- (1) Bealin C 4 (after H.S. Crawford) (2) Torshov Fragment (after Bakka) (3) Detail of Bealin C 4 (after Henry) (4) Detail of Torshov Mount	65-66
15.2	Birds and Animals with Spiralled Bodies:- (1) Clonmacnoise I D 3 (2) Lindisfarne Gospels (after Bruce-Mitford) (3) Aberlemno II (4) Book of Mac Regol	65-66

16	Processions of Animals with Interlaced Bodies, reconstruction of Clonmacnoise IV D 8 and Tihilly D 2	66-67
17.1	Anthropomorphic Motives:- (1) Banagher C 3 (2) and (3) Halsan Mount (after Bakka) (4) Book of Kells (5) Book of Mac Regol	69-70
17.2	Anthropomorphic Motives:- (1) Ahenny I A 2 (2) Market Cross, Kells (after Henry) (3) Meigle XXVI (4) Togherstown Mount (after Henry) (5) Old Kilcullen (after Henry)	69-70
18	Inhabited Vine-Scroll:- (1) Clonmacnoise IV C 3 (2) South Cross, Kells (after Henry) (3) Book of Kells (after Henry)	72-73
19	Inscription on Bealin A 4 (after Macalister)	88-89
20.1-20.2	Diagrams to show the form of Kilkieran I	99-100
21	Ahenny A 1, construction of spirals	100-101
22	Step Patterns:- (1) Ahenny I C 3 (2) and (3) Ekerö Crozier (4) Copenhagen Shrine	113-114
23	Table showing the incidence of the Help of God iconographic cycle	121-122
24	Seir Kieran D 3: reconstruction of iconography	122-123
25.1-25.2	Comparisons of the dimensions of Kilree and Killamery	133-134
26.1	Dragonesque Motives:- (1) Killamery C 1 (2) St Germain Plaques (3) Ekerö Crozier	
26.2	Dragonesque Motives:- (1) Halsan Mount (2) Tessem Mount (3) Killamery Brooch (detail)	133-134
27	Displayed Beasts:- (1) Killamery C 1 (2) Steeple Bumpstead Boss (3) Vatne Mount (4) St Ninian's Isle Hanging Bowl (after Small <u>et al</u>) (5) Meløy Mount	140-141
28	Kilree B 4, interlace grid	141-142
29	Kilree and Killamery, David Iconography	149-150
30	Tihilly, reconstruction of the crosshead	170-171
31	Table showing the repertoire of interlace ornament on Kinnitty I and Tihilly	173
32	Table showing the Iconography of the Granite Crosses	188-189
33	Table showing the incidence of Passion Cycle iconography	223

34	Table showing Harp and Lyre types used in David iconography	223
35	Clonmacnoise V: Inscriptions on A 16 and C 16 (after Petrie and Ó Murchadha)	248-249
36	Diagram in the Book of Mulling (after Lawlor)	281
37	Diagram to show terms used to describe parts of a cross	324-325
38	Capstone Types	324-325
39	Crosshead Types	324-325
40	Moulding Types	324-326
41.1-41.4	Glossary	325-326

Acknowledgements

There are many people without whose help this study would never have been contemplated, let alone completed.

In Ireland I would particularly like to thank Clare Bancroft, Mary Gibson, Katherine O'Herlihy, Mrs. Mitchell and Mick and Clare Moore for their constant generosity in providing me with accommodation during prolonged fieldwork. I would also like to thank the staff of the National Museum of Ireland, the Board of Works, the Keeper of the Manuscript Room in Trinity College, Dublin and my friends in the Archaeology Department in University College, Dublin.

In Durham I would first like to thank those who shared the Archaeology Department graduate room with me 1976-9 for their constant advice and encouragement. I am also grateful to Tom Middlemass for help with the photographs, the staff in charge of inter library loans at Palace Green for their very real efficiency and the staff of the Cathedral Library.

There are many others I would like to thank: particularly Professor Kenneth Jackson for help with the inscriptions, Tomos Bemgttsson and Stuart Edwards for help with photographs, Gwynedd Williams and the staff of U.C.N.W. print unit for help with production, and my typist, June Hughes; also Ian Fisher, Robert Stevenson, John Hood, Frances Lynch and my parents for their discussion and encouragement.

Lastly, to my supervisor, Rosemary Cramp, whose enthusiasm for the subject is so infectious, I offer my heartfelt thanks.

Chapter I. INTRODUCTION

It is now fifty years since Françoise Henry wrote La Sculpture Irlandaise pendant les Douze Premiers siècles de l'ère Chrétienne (1933). However it remains the only substantial work devoted entirely to the Irish sculpture of the Early Medieval Period. It consists of a detailed discussion of the development and use of the various types of decoration, both ornamental and figural, found on Irish sculpture and in particular the stone crosses, a classification into groups of monuments and a consideration of their chronology. It also includes a valuable set of plates illustrating both the monuments themselves and some of the comparative material.

The background to this book can be seen in the gradual re-awakening of interest in Irish antiquities which had taken place in the previous hundred years. One or two pieces of sculpture had been recorded before this, for example the crosses at Clonmacnoise by James Ware (1658), but the real beginning of Irish archaeology may be seen with the inauguration of the Ordnance Survey of Ireland in 1828. The men engaged in this enterprise, for example Petrie, O'Donovan and O'Curry, were employed amongst other things to record antiquities and it was as a result of their fieldwork that many of the Irish crosses were first recognised (Kenney 1929, 62-4). This part of the Ordnance Survey was unfortunately abandoned in 1839 but the impetus had now been given for many of the crosses to be recorded in detail. Amongst those who undertook this the work of George Petrie (1872, 1878), Margaret Stokes and H.S. Crawford is the most important. H.S. Crawford in particular was responsible for producing the only catalogue of Irish sculpture so far attempted (1907a, 1908a, 1912, 1913, 1916) and a detailed record of some of the ornament (1926a). As Françoise Henry (1933, 12) acknowledged in La Sculpture Irlandaise her debt to him was great.

The only other early book is A. Kingsley Porter's The Crosses and Culture of Ireland (1931). This is an impressionistic account and should be used with care as it frequently lacks accurate observations and is inclined to opt for obscure mythological interpretations of quite clearly Scriptural iconography.

Since 1933 Françoise Henry has dominated research in Early Medieval



Irish Art. As well as writing many specialist papers she has been very successful at imparting her enthusiasm for the subject to a wider audience in more general but scholarly books (e.g. 1940, 1964, 1965, 1967, 1970). The work of Helen Roe, likewise spanning the last fifty years, concentrating on specific aspects of iconography and the monuments is also important.

However, apart from Crawford's provisional lists and a rather superficial compilation of views on Irish figure sculpture (Sexton 1946) there is still no systematic corpus of Early Medieval sculpture for Ireland. There is nothing to approach the monumental studies which have been undertaken in other parts of the British Isles, Scotland (Allen and Anderson 1903), the Isle of Man (Kermode 1910), Wales (Nash-Williams 1950) and the much awaited British Academy series for England (Cramp forthcoming). The first aim of this thesis is to provide a small contribution to a systematic and detailed corpus of the Irish sculptural material of the Early Medieval Period. The second is to re-examine work done in the past on this sculpture by Françoise Henry and others and to re-assess it in the light of recent excavation and research, which, in the past few years, has so much broadened and changed our view of the Early Medieval Archaeology of the British Isles.

It was decided that if the sculpture was to be studied properly it would not be possible either to tackle the whole of Ireland at once or to look at every type of monument. Therefore after some consideration it was decided firstly to concentrate on the Early Medieval sculpture of Offaly, Kilkenny and Tipperary and secondly to limit the study to the crosses and related sculpture only.

The geographical area chosen (Map I), delineated as it is by modern boundaries, is not ideal but ancient land divisions are frequently difficult to define accurately. The principle reason why this area was chosen is because a considerable number of large stone crosses are located within these three counties. In fact the majority of the crosses are found within the ancient Kingdom of Ossory (see p 95) with the addition of the important monastery of Clonmacnoise in the North West and some of the granite crosses of the Barrow Valley to the East. The decoration of the crosses in these three counties covers almost the entire range of both abstract ornament and figural representation and therefore it was thought to be a good area to study in depth in order to attempt a re-assessment of the chronology. More particularly, in this area are concentrated the crosses decorated primarily with Hiberno-Saxon abstract ornament. This ornament has

never been recorded systematically or studied in depth and it was thought that by doing this it might be possible to make more detailed comparisons between the monuments themselves, with Hiberno-Saxon metalwork, manuscripts and sculpture elsewhere, and with more distant objects such as Eastern textiles or Continental ivories.

The counties of Offaly, Kilkenny and Tipperary contain a very broad range of Early Medieval sculpture. The types studied here have been restricted primarily to freestanding crosses. In common parlance these monuments are frequently referred to as 'high' crosses. In this study the word 'high' has been omitted as it is thought to be superfluous. Other monuments discussed include freestanding shafts, a couple of miscellaneous fragments which may once have been part of crosses or shafts, and a single large freestanding slab, Gallen Priory I. These monument types were chosen primarily because they are usually copiously decorated. Although a wide variety of grave markers are also found in this area with large concentrations at Clonmacnoise and Gallen Priory, it was decided not to include them within this study. The range of ornament on them is on the whole rather different (see Appendix 3) and they deserve more detailed recording and consideration in their own right. This has already been undertaken to some extent by Petrie (1872, 1878), Macalister (1909) and Lionard (1960-1).

Originally it had been intended that within these three counties every cross and related piece of sculpture belonging to the Early Medieval Period should be discussed in detail. In this context the Early Medieval Period is considered to be c400-c1200 A.D. However it was realised that within this time-span three crosses in this area, Cashel, Mona Incha II and Roscrea II, had already been discussed recently and very competently by two different people, Richard Raleigh (1975) and Elisabeth Farnes (1975). These crosses are principally decorated with a combination of figures carved in very high relief and Viking Urnes ornament in much lower relief. They belong to a period when Viking art styles had become assimilated into Irish art (see Appendix 2) and they are generally considered to demonstrate a revival of interest in the freestanding cross which may be seen as an artistic manifestation of the Reform Movement which brought the Irish church into line with that on the Continent (Hughes 1966, 253ff). They are generally agreed to date to the second quarter of the twelfth century. It would seem superfluous to re-iterate this work so, although they are described and illustrated in the catalogue for the sake of completeness, they are not discussed further.

There are also a number of little known monuments of very uncertain date which may very well be later than c 1200. These monuments are also included in the catalogue and are discussed briefly in Chapter XI.

In Ireland nearly all the crosses and related sculpture are known to be associated with monastic sites. This may be contrasted with the English material which, although it is monastic during the Anglo-Saxon period, is more frequently associated with ordinary church sites during the Anglo-Scandinavian (Bailey 1980, 81-4). In Scotland some of the sites are also monastic, for example Iona, but the status of others, particularly in Pictland, is largely unknown. The Irish monuments, like a large number of those in Scotland, still mostly remain as field monuments. They usually stand in the open, frequently within the bounds of a monastery, the archaeological remains of which can often be traced. Sometimes they stand in a more modern enclosure with a church (frequently abandoned) and graveyard which are thought to have been situated on the focus of an older site. Many are thought to be still in their original position. Only two (Banagher and Clonmacnoise II) have been removed to the National Museum in Dublin. Most of the crosses are National monuments (Harbison 1975). By contrast in England monuments actually in situ such as the Bewcastle Cross are rare. Although they are usually associated with churches and are, very often, church property. They have frequently been brought inside at some point or incorporated into the church fabric, perhaps once they had gone out of fashion, to be rediscovered in some nineteenth century restoration.

This study seeks to concentrate on the monuments themselves, their iconography and ornamental repertoire. It is not intended to go into the rest of the history or archaeology of the sites where the sculpture is found in any detail. The author is not familiar with old Irish. For this reason the surviving inscriptions on the crosses have been examined with the help of Professor Kenneth Jackson. Where possible quotes from the source material have been given in both the original language and in translation.

This study is arranged in the following way. Firstly, there are two general chapters, the first an explanation of the techniques used in the study of the abstract ornament and a categorisation of it, the second a general introduction to the emergence of the freestanding cross in Ireland. The monuments are then discussed in groups according to similarity, those which do not fall into any particular group being dealt with together in Chapter XI. Within each chapter there is a

brief introduction to the monastic sites where the sculpture is situated followed by a discussion of the form and layout of each monument. The decoration, both figural and ornamental, is then discussed in detail, the order of this varying according to what is considered important within a particular group of monuments. Each chapter terminates with a consideration of the chronology of the group and how it fits into the development of Irish Early Medieval sculpture as a whole. Following the final conclusions is a catalogue providing a systematic description of each monument and corresponding plates. This study has taken cognisance of relevant material published up to July 1981.

Chapter II. INTRODUCTION TO THE ORNAMENT

The majority of crosses in Offaly, Kilkenny and Tipperary are decorated chiefly with abstract ornament rather than figural representation. Therefore, one of the aims of this study must be to make a permanent record of what is often very complex decoration in a way which will facilitate comparative study both with sculpture elsewhere and with similar patterns in other media. The object of this chapter is to explain the methods used in the study of this ornament and to attempt to provide a reasonably simple vocabulary for the description of the various types of pattern used in the decoration of Irish sculpture. (Definitions of other special vocabulary are provided in the Glossary.)

All work on Hiberno - Saxon ornament owes a tremendous debt to Romilly Allen's monumental study of the Early Christian Monuments of Scotland (Allen and Anderson 1903, II and III). As an accompaniment to the complete corpus of Scottish sculpture he also provided a detailed discussion of the ornament. The variations of each interlace knot, each spiral and each fret motif were carefully recorded explaining where each were found, both in Scottish sculpture and elsewhere. Furthermore, he also looked behind the actual lines of the pattern in order to determine how such ornament might have been constructed. Although his corpus was completed nearly eighty years ago it is still the most complete study of Hiberno-Saxon ornament attempted and has provided the starting point for all work since (Bain 1951; Bruce-Mitford 1960a, 221-231; Adcock 1974, 1978).

In Ireland the ornamental aspect of the sculpture has been little considered. The main contribution was provided by Henry Crawford's Handbook of Carved Ornament (1926a). The aim of this book was to provide illustrations of the great variety of decoration, both ornamental and figural, found on Irish sculpture of the Early Christian Period, each accompanied by a brief description. As Macalister (op cit, VI) said in his preface to this volume, it provides a suitable stepping off point for a more detailed corpus; unfortunately no more. Similarly, in Françoise Henry's La Sculpture Irlandaise (1933), although it is

divided into different chapters according to different types of ornament, the various patterns are never discussed in more than a general way and no complete corpus or description of ornament is attempted.

Here the different types of Hiberno-Saxon ornament will be treated one by one with the aim of demonstrating both the repertoire used and the constructional methods employed.

1) Interlace

Although it may seem more logical to discuss spiral patterns at the beginning, since they provide the foundation on which other motives in Hiberno-Saxon art are built, here interlace will be treated first as much of the work done on other ornamental types seems to spring from the initial study of interlace. Much ink has been spilt on the problem of the origins of Hiberno-Saxon interlace and where and when it was introduced¹. However, this is not the place to go into these difficulties. Suffice it to say that interlace was becoming a characteristic part of the Hiberno-Saxon ornamental repertoire by the time that the seventh century Durham (Cath. Lib) A.II.10 was illuminated (Nordenfalk 1947, 162ff) and that by the ^{time the} Lindisfarne Gospels (B.M. Cotton, Nero D. iv s III in) were illuminated (c 698-721) the repertoire of interlace ornament had reached its full complexity (Adcock 1974, 60).

In modern times Romilly Allen (Allen and Anderson 1903, II, 202-307) was the first to attempt the study of interlace motives in detail. He made a catalogue of the different interlace knots used and showed how each might be elaborated to produce a different pattern. The basis of this original categorisation was retained by Gwenda Adcock (1974, 64²; 1978) being merely simplified to establish six basic pattern elements (A to F) which each had various elaborations. The increased simplicity of the scheme achieved by Adcock is also used here. A few pattern groups found on the Irish sculpture do not fit into her categorisations and have therefore been added. The first of these is Plaitwork (RA Nos. 501-506) which may be simply categorised according to the number of strands used in each pattern. Secondly, there are a number of 'Closed Circuit' patterns based on elements other than Adcock's A to F. These are the Triquetra Knot (RA No. 798) and patterns composed of circular, oval and hooped rings (RA Nos. 766-776).

The interlace patterns found on the sculpture of Offaly, Kilkenny and Tipperary which are discussed in this study may be found in Fig. 1.

INTERLACE PATTERNS

Fig 1.1

2 STRAND TWIST



Ahenny I A3
 Ahenny II A2, B1, C1, D1
 Drumcullin I A2, C5
 Kilkieran II A1, B1, 2, 4, 5
 C1, D1, 2, 4, 5
 Killamery B1, 6, D1
 Tihilly A2, D1
 Bealin A1

3 STRAND PLAIT



Ahenny I C1

4 STRAND PLAIT



Ahenny I C1
 Ahenny II A2
 Gallen Priory II C
 Kilkieran II B1, 5, 9
 Killamery D7
 Kilree D7
 Kinnitty II
 Seir Kieran A2, B2
 Templeneiry I A1

6 STRAND PLAIT



Ahenny I B1, C1
 Ahenny II B5, C1
 Bealin A2
 Clonmacnoise III B
 Graiguenamanagh II A2
 Kilkieran II A9, B8, D3, 5, 10
 Kilree A1, B4, 5
 Lorrha I D1(?)
 Lorrha II B1, D2
 Ullard A14

8 STRAND PLAIT

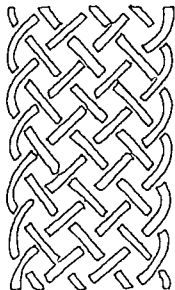

Ahenny II C1
 Clonmacnoise IV B7
 Kilkieran II C1, D10
 Lorrha II D1

10 STRAND PLAIT

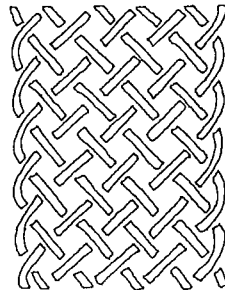

Ahenny IC1
 Kilkieran II D10
 Ullard A11(?)

12 STRAND PLAIT

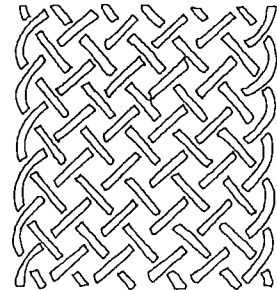

Kilkieran II A7, D10
 Lorrha II A1, B2

16 STRAND PLAIT

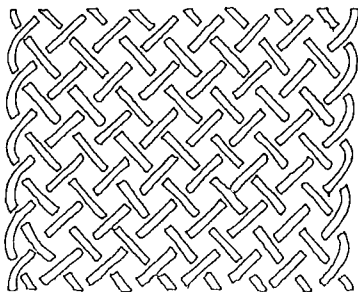

Kilkieran II C3
 Lorrha I A3

22 STRAND PLAIT

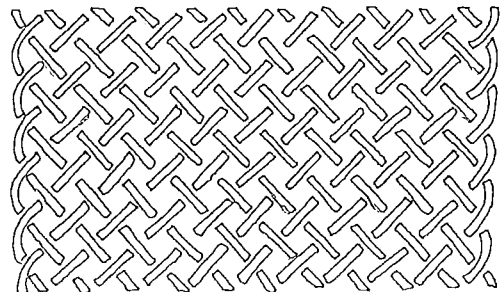

Kilkieran II B10, D9

TRIANGULAR PLAITWORK MOTIF



Killamery B8

A

B

C

D

E

F

BASIC PATTERNS

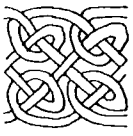

Bealín D3
Clonmacnoise IV B9
Tihilly B5



Clonmacnoise III B1
(adaptation)



Ahenny IC1
Bealín C1
AS A ROUNDEL:-
Bealín A1
Ahenny IA1
Clonmacnoise IA1
Clonmacnoise IV C1

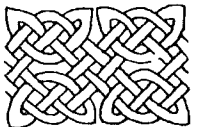

Bealín B1
Clonmacnoise VI B, D
Ahenny IC1 (adaptation)

TURNED PATTERNS

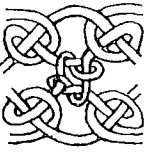

Kinnitty IC7



Clonmacnoise I B3
Clonmacnoise III B1
Clonmacnoise IV B7



Clonmacnoise I B3
Clonmacnoise II B1
Clonmacnoise III B1



Ahenny IC1
Clonmacnoise IV B7



Clonmacnoise III D1
Clonmacnoise IV B7

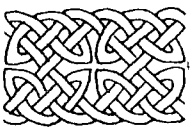

Tihilly D1

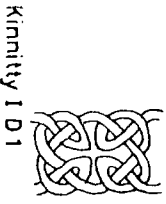
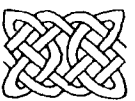

Kinnitty ID1

Fig 1.2

A

B

C

D

E

F

BASIC AND TURNED PATTERNS WITH ADDED OUTSIDE STRANDS OR DIAGONALS

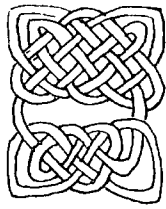

Ciommacnoise IV B 4

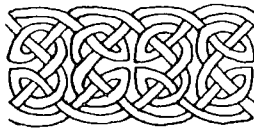

Bangher D 3

SPIRALLED AND SURROUNDED PATTERNS

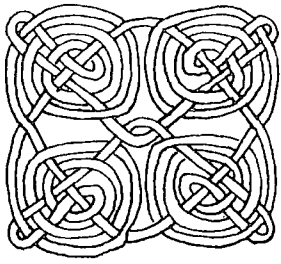

Ciommacnoise I A 4

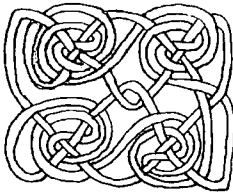

Ciommacnoise IV A 4

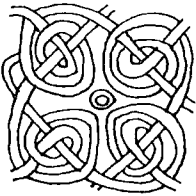

Ciommacnoise I A 2

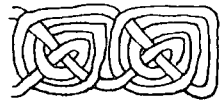

Ciommacnoise IV D 10

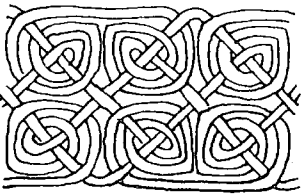

Ciommacnoise IV A 10

Fig 1.3

ENCIRCLED PATTERNS

A

B

C

D

E

F

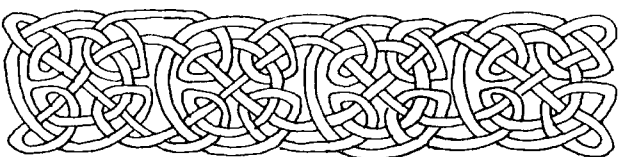

Ciommacnoise IV C 7

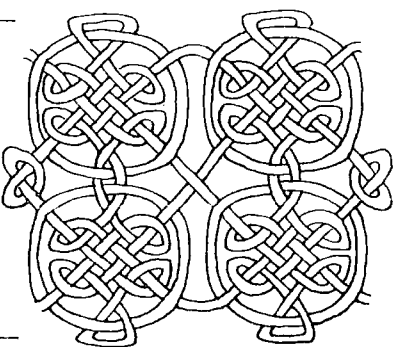

Kinnitty IA 2
Durrow I C 10 (similar)

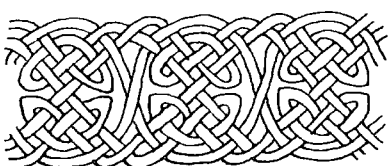

Banagher D 3

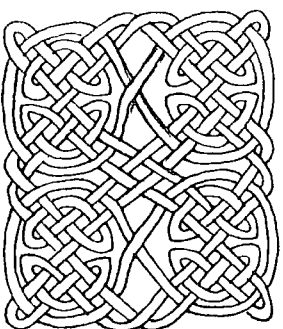

Bealín A 3
Ciommacnoise IA 5

Fig 1.4

A

B

C

D

E

F

DOUBLE STRANDED PATTERNS

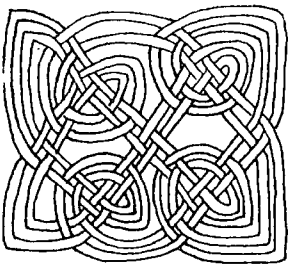

BASIC A
Kinnitty 1A 4
Tihilly C8

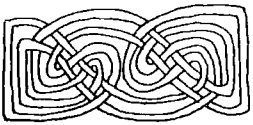

HALF B
Kinnitty 1C9
Tihilly D 4

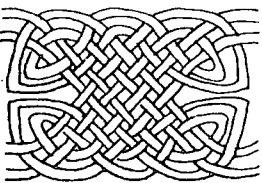

TURNED D
Banagher C3

PATTERNS WITH MORE THAN TWO ELEMENTS ABREAST

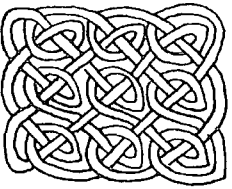

BASIC A
Banagher C1

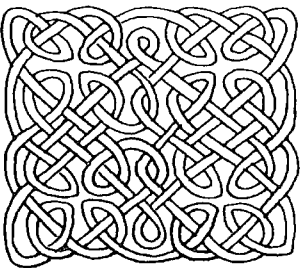

BASIC C
Clonmacnoise 1A 3
Clonmacnoise V1 C
(adaptation)

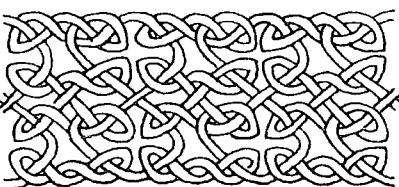

VARIATION OF TURNED D
Banagher B 3

Fig 1.5

A

B

C

D

E

F

HALF PATTERNS



Clonmacnoise V D 7,8
Drumculin I B1(?)



Beclin D1,2
Graiguenamanagh II A 4
Kinnitty I B 2
Kinnitty II

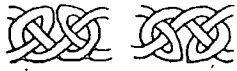

Ahenny I C 1

SIMPLE PATTERNS



Clonmacnoise IV B6
Kinnitty I D 3



WITH OUTSIDE STRANDS
Clonmacnoise IV D 5
Tihilly B 2



Ahenny I C 1
Durrrow I C 2
Killamery C 6, D 8
Kinnitty I A 2
Tourreen Pedcaun A 2



Ahenny I C 1



Ahenny I D 1
Ahenny II B1, D1



Ahenny I C 1
Banagher C 3
Kinnitty I C 5



Ahenny I D 4
Ahenny II A 3, 4, B 5, C 1, D 4, 5

Fig 1.6

SIMPLE PATTERNS cont'd

A

B

C

D

E

F



Ahenny II A1



Ahenny IA 3



Killamery A 15



Ullard A 15



Ahenny IA 6

AS A ROUNDEL

Ahenny IA 1

Bedlin A 1

Kilree C 2



VARIATIONS

Kilree B 5



Killamery D 8



Clonmacnoise II E 1

Fig 1.7

MISCELLANEOUS INTERLACE PATTERNS

CLOSED CIRCUIT PATTERNS

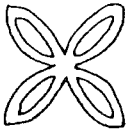

FOUR PETAL MARIGOLDS
Killemery C 6



Kilkieeran II B9

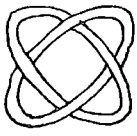

RA No. 766
Graiguenamanagh IB3,C2
Graiguenamanagh II C1
Lorrha II C1

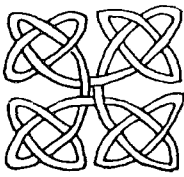

RA No. 692
Ullard A 16

OTHERS

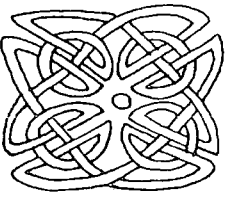

ELEMENT C AS
A RECTANGLE
Durrow I D4

TRIQUETRA KNOTS

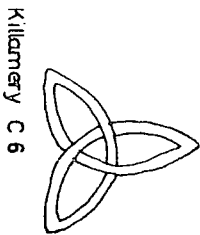

Killemery C 6

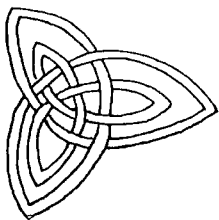

DOUBLE TRIQUETRA
Bealin C 2

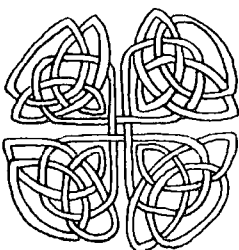

ROUNDEL
Clonmacnoise IV C1

INTERLOCKING PATTERNS

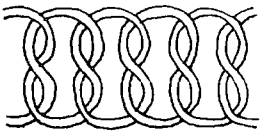

RA No. 573
Kilree D5

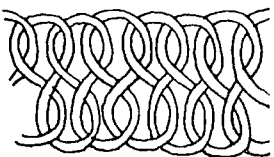

Banagher B1
Bealin D5



RA No. 519
Clonmacnoise IV B2

Fig 1.8

It will be noted that the complete repertoire of interlace ornament is surprisingly small even though a wide variety of patterns are included. This is interesting because the repertoire of interlace displayed in both Pictland and Northumbria (Allen and Anderson, II, 202-307; Adcock 1974) is much greater. Whether this difference is significant seems more difficult to determine.

One other thing which should be pointed out is that the voids made between interlace knots frequently make the form of a cross. It seems likely that these cross symbols are intentional and a particularly good example of this may be seen on Clonmacnoise I A 2 (see p 54). Robert Stevenson³ (1974, 39-40) has hinted at the possible Christian significance of the cruciform shape on the Hunterston Brooch and the cross shape is certainly extremely important in manuscript illumination. It provides the foundation for the display of ornament on many carpet pages from the Book of Durrow onwards (Åberg 1943, 101-2). A good example of the moulding of the ornament to fill the cross shape is provided by the only surviving carpet page from the Lichfield Gospels (Lichfield Cath. Lib. s VIII') (Nordenfalk 1977, pl.26).

Romilly Allen (Allen and Anderson 1903, II, 143ff) believed that interlace was constructed on a diagonal grid of squares. He traced the artistic origin of such interlace patterns back to simple plaitwork designs which may be logically constructed on a diagonal grid (see Glossary) since the lines of the plaitwork strands actually follow the lines of the grid. George Bain (1951, 25-55) examined the problems of the construction of interlace with the eye of an artist eager to adapt them to modern usage. Like Allen he suggested diagonal grids might be used but he also indicated that the points where interlace strands were to cross, at least on the simpler patterns, could be indicated merely by a dot. The presence of constructional grids for interlace ornament was actually proved by Bruce-Mitford (1960a), who demonstrated that the abstract decoration of the Lindisfarne Gospels was drawn out using geometric grids for guidance, some of these being still traceable as pinpricks on the other side of the page. He discovered that elaborate interlace patterns were here built up on square rather than diagonal grids as Romilly Allen had first suggested. Furthermore, he also put forward the idea that an investigation of the scale of the constructional grids used might indicate a particular series of measurements in use amongst a particular group of artists. The germs of these ideas have since been worked on and borne out by

Gwenda Adcock in her study of Northumbrian sculptural interlace (1974). Firstly, she discovered that the interlace patterns found on Northumbrian sculpture were being constructed on square grids. Such grids could be used in one of two ways. Either the crossing points of the grid lines could mark the points where the strands of interlace would actually cross (crossing points) or they could be used to indicate the voids (hole points) between the strands of the pattern. Secondly, she found that the dimensions of such grids could be calculated by measuring the horizontal or vertical distance between the crossing points of pairs of interlace strands (or hole points). The distance between two crossing points is called the 'unit measure'. She also realised that some groups of sculpture not only used a similar ornamental repertoire but also that certain monuments were using the same grid measurements for the construction of these patterns. Wherever possible I have applied these principals to the study of the construction of the interlace ornament on Irish sculpture with the following results.

Firstly, many interlace patterns seem to have been constructed on square grids, the crossing points of the grid indicating the crossing points of pairs of interlace strands. Although no visible signs of a square grid have survived, evidence for this was obtained by making careful measurements of each interlace panel and noting where the distances between the crossing points of the strands were consistently similar⁴. In some instances the distances between the crossing points, the unit measure, was found to be the same for a number of patterns on different monuments within a particular group of sculpture, thereby suggesting that a group of monuments might be linked by their constructional dimensions as well as their ornamental repertoire. This may be demonstrated particularly well amongst the Clonmacnoise monuments (see p 50 ff). Some interlace patterns may have been constructed on square grids where the crossing points of the grid indicate the hole points between the strands. However no evidence has been found for this.

Secondly, as Romilly Allen originally suggested, there seems to be some indication that diagonal grids were used for the construction of interlace ornament on some monuments. The possibility of diagonal grids is most apparent amongst the Ossory crosses (see p105) where hardly any complex knotwork is used, the interlace being confined to simple plaitwork patterns which could logically be constructed on a diagonal grid. The possibility of interlace patterns set out on diagonal grids first presented itself when examining the plaitwork on Ahenny II (see p107). It was noted that patterns contained within

regular areas were tackled with a fair degree of competence but that where irregular areas were decorated, for example Ahenny II C 1, the sculptor has experienced obvious difficulties which resulted in an uneven pattern. It is impossible to be absolutely certain whether any grid more complex than a mark indicating the crossing points of pairs of strands was attempted but when careful measurements were taken it was noted that the diagonal distances between the crossing points were consistently more even than the horizontal or vertical ones. On Lorrha II (see pl10) a diagonal grid is suggested by the fact that the plaitwork strands do not cross at right angles. The horizontal and vertical distances between the strands thereby differ considerably but the diagonal unit measurements remain surprisingly even. On Kilree B 4 the use of a diagonal grid as the constructional basis of a plaitwork pattern can perhaps actually be demonstrated since fragments of the original grid system may still be in existence (see pl41).

One suspects that many of the simpler patterns may have been constructed merely by marking the crossing points of pairs of strands as Bain (1951, 29) has suggested. 'Motif pieces' also give some clues since sometimes traces of the constructional process are still visible. Rough divisions using a square grid may be seen on a slate from Gransha Mound, Co Down (O'Meadhra 1979, No. 75). There is a vertical line down the centre of a plaitwork pattern and hole points are used to construct a simple interlace motif on two pieces from High Street, Dublin (op cit, Nos. 37, 43). Certainly some kind of constructional aids seem to have been essential for achieving an even interlace pattern free of mistakes. The possible results of failing to do this may be seen at Kilkieran II (see pl09).

2) Spirals

Unlike interlace, which becomes a characteristic ornamental element of Hiberno-Saxon art in the Post Roman period, the use of the spiral in both Britain and Ireland has a much longer history since it is also an important ornamental element of the Celtic Iron Age. During the long period of its usage the motif changed and evolved but never entirely lost sight of its La Tène origins. In the early period Celtic spiral ornament, which was ultimately derived from the Greek palmette and tendril scroll, maintained a delicate balance, combining separate asymmetrical elements to produce an overall composition which gave the impression of symmetry (Kendrick 1938, 8ff).⁵ However, the

influence of Rome brought changes to Celtic art in Britain, the adoption of symmetrical patterns and classical elements such as volutes and peltas. 'Cet art qui n'était que lignes fluides, courbes imprévues, le voici tout à coup converti à la logique des ordonnances classiques' (Henry 1933, 39). Towards the end of the Roman Period in Britain native art, which never entirely died, can be seen to re-assert itself taking ornamental elements from the Romano-British milieu and adapting them to produce the characteristic spiral ornament of the Early Christian Period (Kendrick 1938, 59). However, in Ireland such an evolution is more difficult to trace. Classical influence is apparent although there was no physical intervention. Therefore, as Françoise Henry says (1965, 9) in Ireland it seems unlikely that there was ever any chronological gap between the late La Tène objects and the brooches and pins of the fifth and sixth centuries.

The grammar of Dark Age spiral ornament is very much less complex than that of the Iron Age since there are only two basic elements, the 'S' scroll and the 'C' scroll (see Fig. 2), both of which are used to join adjacent spirals. As Romilly Allen said (Allen and Anderson 1903, II, 337, No. 1025)



'There are only two ways of connecting together two adjacent spirals. If the two spirals have an opposite direction of twist, the curve will be C shaped; but if they have the same direction of curve, it will be S shaped.'

He went on (op cit, 387 ff) to catalogue the spiral patterns found amongst the Pictish sculpture. The broad principals of this classification have been retained here with some modifications. As will be seen in Fig. 2, the patterns containing only 'C' scrolls and those containing only 'S' scrolls have been placed in separate columns. The third column contains patterns which combine both elements. The two simple elements, used either separately or together, may be elaborated in a number of different ways. In this Romilly Allen's classification has been followed:-

- | | | |
|-----|--|---|
| I. | <u>Single Borders</u> | ie Patterns using a single row of spirals (RA Nos. 1042-1048). |
| Ia. | <u>Borders composed of Large and Small Spirals</u> | ie Patterns using a single row of spirals but other small spirals are included as accessories in the pattern (RA Nos. 1049-50). |
| II. | <u>Double Borders</u> | ie Patterns using a double row of spirals (RA Nos. 1051-1063). |

SPIRAL PATTERNS

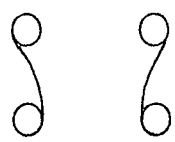
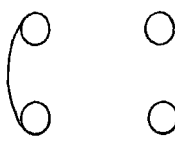
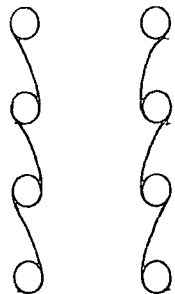
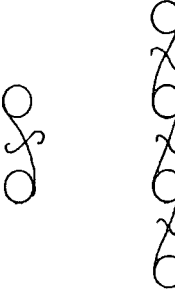
Fig 2.1

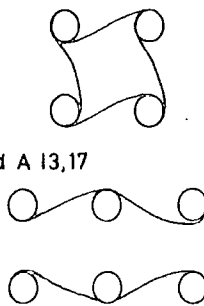
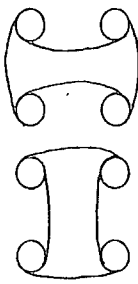
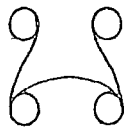
'S'	'C'	COMBINED
<p>SIMPLE ELEMENT</p>  <p>Clonmacnoise I D 2 Kilree A 1</p>	<p>'C'</p>  <p>Clonmacnoise I B 1 Gallen Priory I A 1</p>	
<p>I SINGLE BORDERS</p>  <p>Ahenny I A 1, B 5, C 4, D 5 Clonmacnoise V A 5, 6 Durrow I A 5, 6 Killamery B 5 Kitree B 5 Kinnitty I B 3</p> <p>Ia</p>  <p>Clonmacnoise IV B 8 Kinnitty I D 2 Tihilly B 2</p>	 <p>Ahenny II A 5, 6 Clonmacnoise V B 7, 8</p>	
<p>II DOUBLE BORDERS</p>  <p>Ullard A 13, 17</p> <p>Killamery A 14</p>	 <p>Ahenny I A 1</p>	 <p>Bealin D 4</p>

'S'

'C'

COMBINED

DOUBLE BORDERS contd.

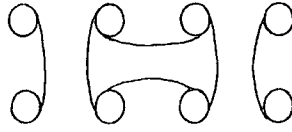

Ahenny I B6,D6

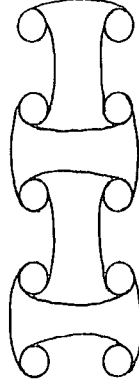

Durrow I D9
Kilkieran I C

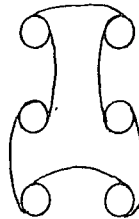

Ahenny II B 5,D 5

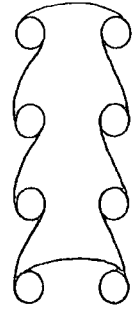

Clonmacnoise II A
Tihilly D 3

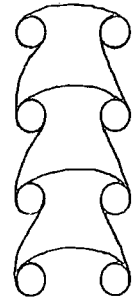

Banagher B 2,D 3

III PATTERNS WITH MORE THAN TWO ROWS OF SPIRALS

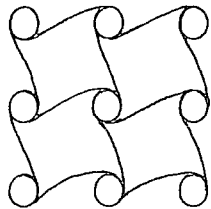

Graiguenamanagh I C 2

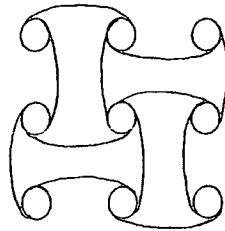

Kinnitty I C 8

V SQUARE PANEL PATTERNS

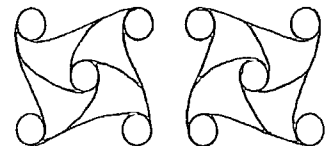

Ahenny I B3,C2,D 3
Ahenny II A7,8,B3,C2,D3
Clonmacnoise V A 1
Kilkieran II A 8
ELABORATIONS
Clonmacnoise IV C 2
Clonmacnoise V B 1

Fig 2.2

'S'

VI ROUNDELS

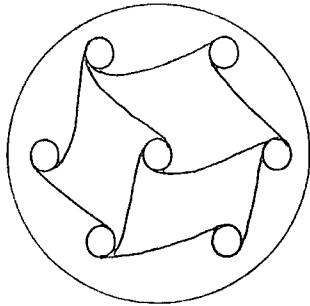

Tybroughney A

'C'

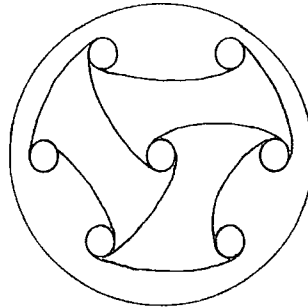

Drumcullin I C1

COMBINED

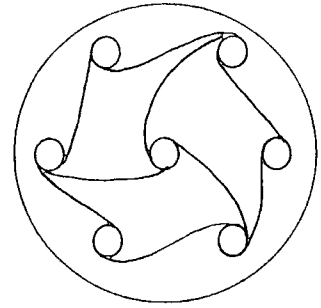

Kinnitty I C1
Tihilly C1

Fig. 2.3

- III. Rectangular Panels with Spirals arranged in Rows
(Patterns with more than two rows of spirals)
(RA Nos. 1064-1066)
- IV. Rectangular Panels with Spirals arranged symmetrically on each side of an axis in the Plane of the Paper.
(Mirror Image Patterns)
(RA Nos. 1067-1071)
- V. Spiral ornament filling square spaces.
(Square panel patterns)
(RA Nos. 1072-1085)
- VI. Spiral ornament filling circular spaces.
(Roundels)
(RA Nos. 1086-1111)

Romilly Allen's seventh category 'Spiral ornament filling Semi-Circular, Crescent-shaped and Triangular Spaces' does not apply as it relates to the ornament of Pictish symbols and therefore is not included.

As can be seen (Fig. 2) the actual repertoire of spiral ornament amongst the monuments of Offaly, Kilkenny and Tipperary is surprisingly small and most of the patterns are relatively simple. The complex 'mirror image' patterns are not found in this area of Ireland at all although there are examples on crosses further to the north, for example Kells West (Roe 1966, Pl XVIII), and here one suspects Scottish influence as patterns of this type were very much more common in Pictland and Dalriada.

The techniques of construction of spiral patterns must have evolved with the advent of spiral ornament itself as the execution of its complexities would have been impossible without some kind of mechanical aid. Compasses were used to obtain the intricate series of circles necessary to construct such patterns and Jope and Wilson's study (1957, Fig. 2) of the Bann Disc demonstrates the great care with which the curves and spirals were mapped out, the result being the apparently effortless lines of the finished ornament. Françoise Henry (1965, 218-20, Fig. 31) has gone on to show the methods of construction employed in the spiral composition on the Lough Crew bone slips. Here a grid of rectangles was ruled out to provide the basis for the ornament, the centres of the spirals being placed at crossing points on the grid. The spiral patterns in the Early Christian Period seem to have been constructed in a similar way. Bruce-Mitford (1960a, 226), in his study of the Lindisfarne Gospels, found lines and prick marks on the reverse of f26V indicating the spiral ornament had been constructed on a rectangular grid with additional diagonals. It therefore seemed likely that the spiral patterns on Irish sculpture might be constructed

Fig 3 CONSTRUCTION OF SPIRAL PATTERNS

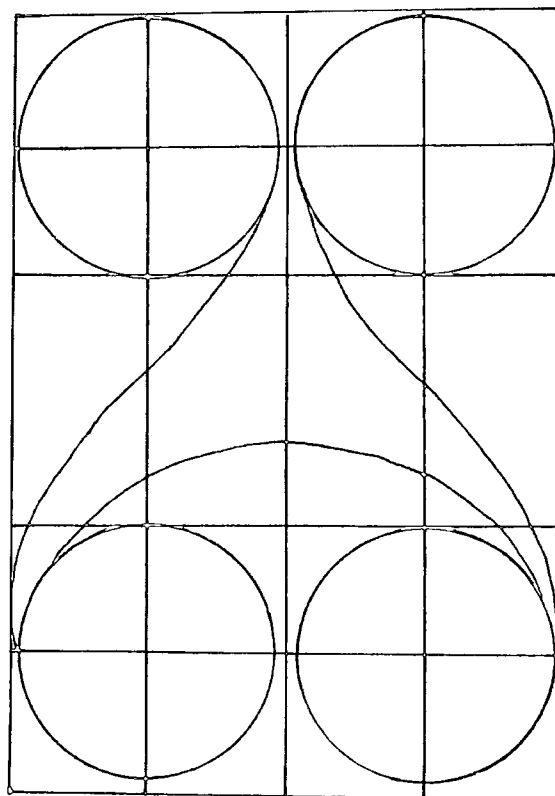
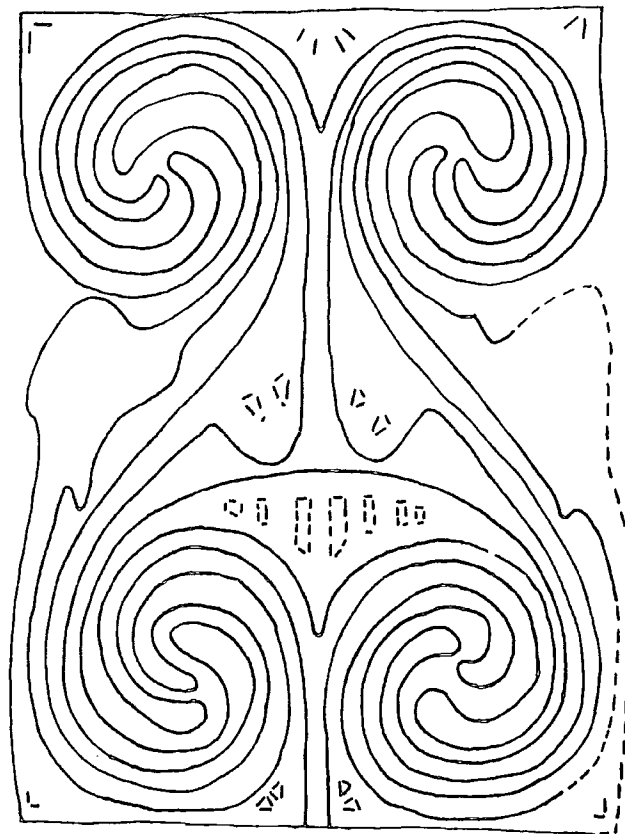

0 5 10 15 20 cm

in a similar way and the question also arose as to whether, like the interlace, the grids might be of significant dimensions, perhaps linking patterns on a particular cross or a group of monuments. Close observation suggests that the Irish sculptural patterns may have been constructed using both square and diagonal grids. An example of the former is provided by Baragher D 2 (see p 76), of the latter by Ahenny I C 2 (see p101). It seems likely that the grid lines would have been placed so their crossing points marked the centres of the spirals, perhaps with further lines acting as a guide for the spiral scrolls and the edges of the spirals themselves (Fig. 3). The arcs of the spirals could then have been constructed using a compass. Whether specific dimensions were being used for either the grids or the diameters of the spirals is more difficult to determine although some results were obtained. The most impressive of these was the realisation that the spiral ornament on Ahenny I A 1 was constructed on a square grid using a unit measure of 2.5 cm and that this also tied in with the unit measure used for the plaitwork on C 1 and the dimensions of the crosshead itself (see pp101,106). More work on this could lead to further discoveries along these lines.

Roundel spiral patterns were probably constructed in a rather different way using a mixture of lines radiating from the centre point of the roundel and concentric circles (Fig. 3).

3) Frets

Fret patterns, which are also sometimes called key patterns because of their superficial resemblance to slots cut in an old fashioned key, have a long and varied history, similar ornament having evolved as far apart as Greece, Mexico and China (Allen and Anderson 1903, II, 308-9). In Ireland it first appeared during the Iron Age, where it may be exemplified by the border pattern on the Turoe Stone (Duignan 1976, Fig. 1). Quite how it re-emerged in the Early Christian Period is rather obscure. Suffice it to say here that by the time the Book of Durrow (Dublin TCD 57) was illuminated it had become an important element of the Hiberno-Saxon ornamental repertoire.

Romilly Allen (Allen and Anderson 1903, - II, 312 ff) discussed in some detail the various elements which make up fret ornament and the ways in which it was constructed. The patterns could be constructed either on a square or a diagonal grid or a combination of the two (RA Nos. 859-60, Nos. 871-4). In his view only the main pattern elements were drawn with the aid of a grid, the terminals being added afterwards

FRET PATTERNS

Fig 4.1

BASIC ELEMENTS



SUBORDINATE PATTERN ELEMENTS USED IN CONJUNCTION WITH BASIC ELEMENTS

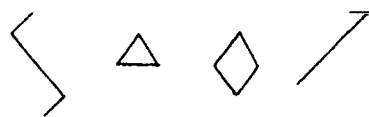
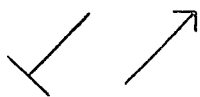

PATTERNS WITH BASIC ELEMENTS USED BY THEMSELVES



Graiguenamanagh I B2
Killamery D11
Kilree C12
Mona Incha II C2

Kilree B5

BASIC AND SUBORDINATE ELEMENTS, BORDER PATTERNS (RA Nos.932-954)



Clonmacnoise IV D6



Kilree D7



Ahenny IA1

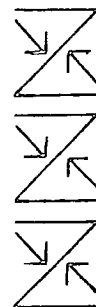

Kilree D7

BASIC ELEMENTS CROSSED AT RIGHT-ANGLES

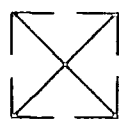

Clonmacnoise IV D11, B1

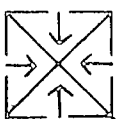

Ahenny II B5, D5



PATTERNS USING HALF ELEMENTS (RA Nos. 924-931)

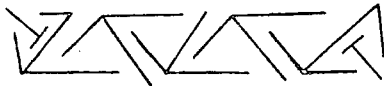

Clonmacnoise IV B5

CARPET PATTERNS (RA Nos. 973-984)

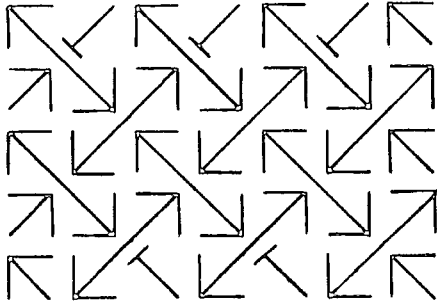

Gallen Priory I A2
Killamery A11

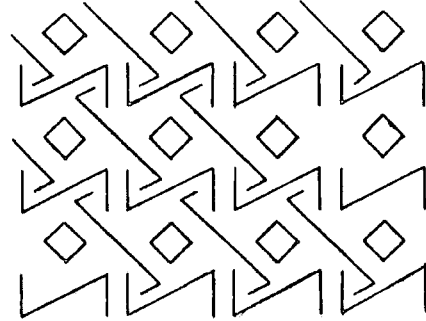

Ahenny I A3

COMBINED ELEMENTS

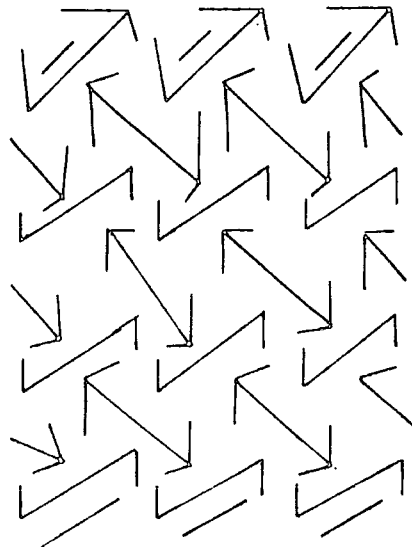

Kilree C10

BASIC ELEMENT

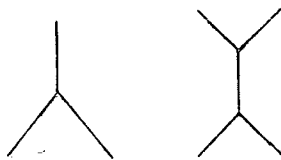

CARPET PATTERN:
Clonmacnoise IV C1

Fig 4.2

BASIC ELEMENTS



Kinnitty I D 4

CARPET PATTERNS (RA Nos. 966-971)

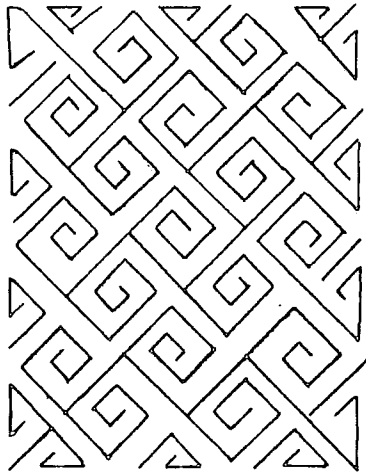

Killamery A 12
Kilree C 9
VARIATION ON SQUARE GRID
Graigenamanagh I A 9
BORDER PATTERNS WITH CURVED
TERMINALS
Graigenamanagh I B 2

MISCELLANEOUS PATTERNS RELATED TO FRETS

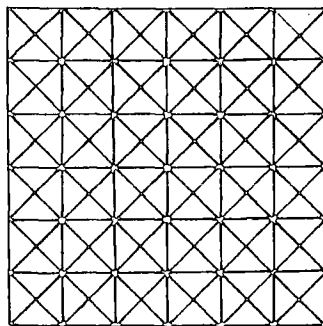

Kilkieran II B 3

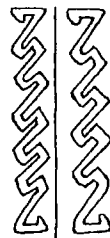

Ahenny II D 4

Fig 4.3

freehand. However, George Bain (1951, 75-81) suggested that the constructional grids for fret ornament were very much more complex and that they would have been used as a basis for every detail of the pattern. This implies very complex grids on a small scale but it would certainly seem to make the drawing of the more complicated patterns easier. However, the need for these has been disproved, at least for the Lindisfarne Gospels, since Bruce-Mitford's examination (1960a, 224) of the surviving grids used in the construction of the fret ornament has demonstrated that a grid was only used for the construction of the major elements. A 'motif piece' from Ballinderry I also shows patterns set out in this way (O'Meadhra 1979, No. 10).

Romilly Allen (Allen and Anderson 1903, II, 312ff) showed that the type of grid used is crucial to the type of fret pattern drawn and the elements it contains. The basic elements are \lfloor and \lrcorner which are the straight line equivalents of 'S' and 'C' scrolls in spiral patterns. \lfloor elements are usually placed in pairs so as to form a \lrcorner . The terminals of these can be elaborated to produce much more complex patterns (RA Nos. 827-832). Where a diagonal or a combination of square and diagonal grids are used the elements may become distorted; \lrcorner may become \sum and \lrcorner \curvearrowright or \wedge ⁶. The terminals of these elements may also be elaborated, frequently with a series of small triangles but sometimes spirals are also introduced into the pattern (RA Nos. 881-5B).

Romilly Allen (ibid, 331-363) went on to catalogue the wide variety of fret patterns which are found on the Scottish monuments and elsewhere. Indeed the variety, complexity and profusion of this type of ornament in Pictland could suggest that it was developed here. Both square and diagonal grids are used and a combination of the two but the first is used less often than the others. The fret patterns on Welsh sculpture, although on the whole less accomplished, are quite common and all types are characteristic (Nash-Williams 1950) and it is interesting to note that those constructed on a square grid are more common here than in the north (Allen and Anderson 1903, II, 340). However, in Anglo-Saxon England there are very few fret patterns (Cramp forthcoming). In Ireland the number of fret patterns is not great (Fig. 4) and the repertoire of ornament seems fairly limited. Diagonal and a combination of diagonal and square grids are favoured and the only exception to this so far noted apart from simple crenelated patterns is Kinnitty I D 4 (see p 179).

The fret patterns on the Irish sculpture were examined for signs



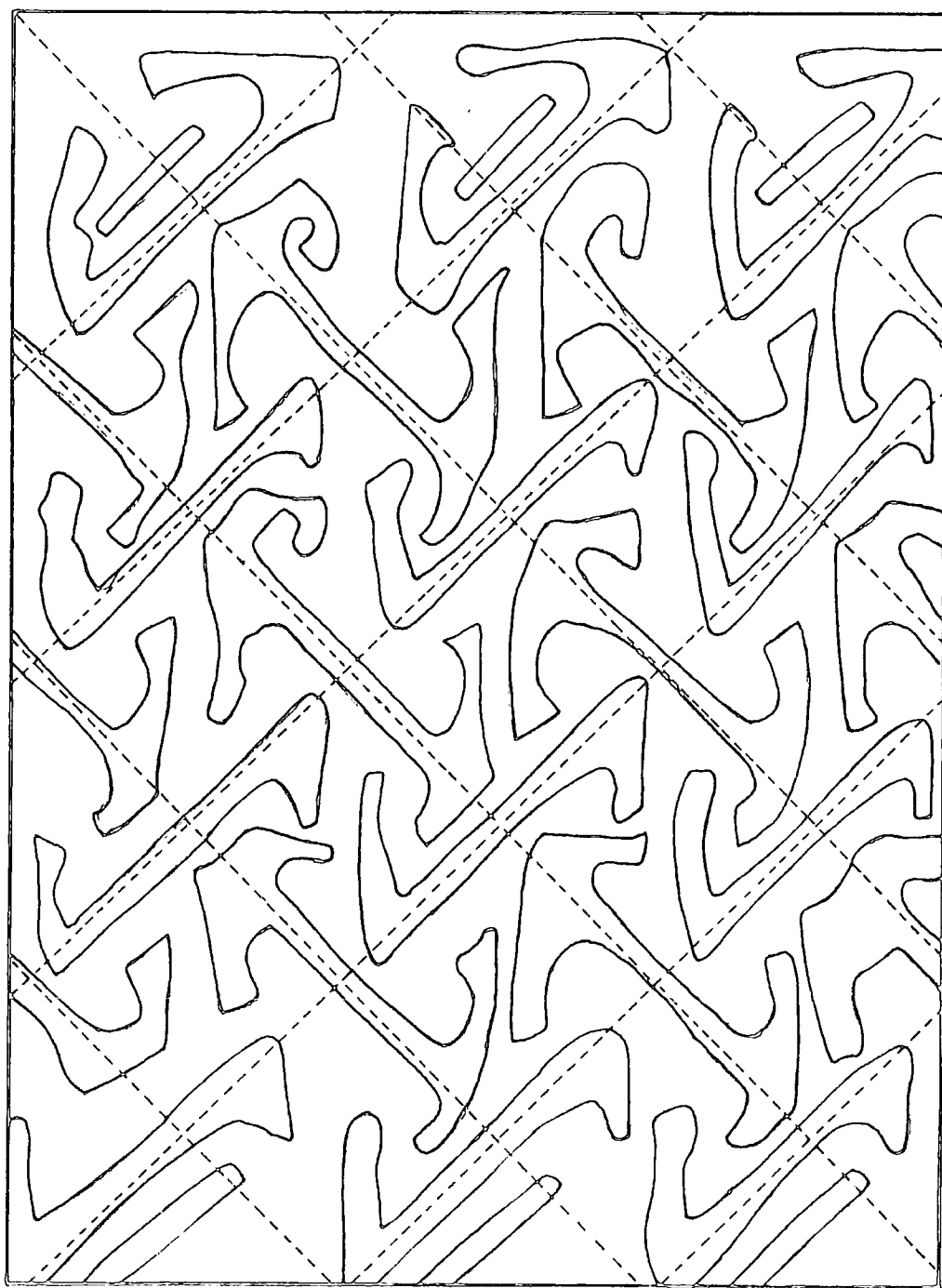

Fig 5 EXAMPLE OF CONSTRUCTION
OF FRET PATTERNS:
KILREE C 10



0 10 20 30 40cm

Diagonal Unit Measure: 9cm

of constructional grids. This was done by measuring along the lines of the elements (Fig. 5) and the likelihood of a grid may be seen very clearly on Kilree C 10 where the pattern elements almost seem to be joined by ruled lines. It seems likely that, at least in some instances, grids with specific unit measures were preferred and this may best be illustrated by the fret patterns on Kilree and Killamery (see p135).

Romilly Allen divided his catalogue into two principal groups of patterns: those based on a square grid (RA Nos. 886-923) and those based on a diagonal grid or a combination of the two (RA Nos. 924-1012). In Offaly, Kilkenny and Tipperary the majority of patterns are made up of  and  elements although there are also one or two examples of  and . An attempt has been made to simplify Romilly Allen's categorisation as his numbering system is not very easy to use because the patterns on the Irish crosses are seldom identical to those in Scotland. Fig. 4 demonstrates this categorisation. The different pattern elements have been placed in columns and the different variations drawn out. The single pattern where a combination of units is used has been placed at the end. In this categorisation no account has been taken of the different types of terminal (RA Nos. 881-885B). Romilly Allen's equivalent pattern numbers have been included where applicable.

4) Step and Chequer Board Patterns

Chequer board patterns consist of a square grid where alternate squares are the same in a similar way to a chess or draughts board. Step patterns are a more complex version of this theme where, instead of alternate squares the same, groups of squares are linked so as to form a unit with a varying size of stepped perimeter (Fig. 6). Such units may be placed singly, used as a border or may be used on larger panels to cover the entire surface with a carpet of ornament. Frequently a cruciform void is formed in the centre of a step unit or between the units where there is a carpet of ornament. This may be seen as a parallel to the frequent breaking and rejoining of the strands in interlace patterns to form cruciform voids (see p 8). These patterns have their background in Vernacular Style metalworking techniques, particularly objects decorated with millefiori and champlevé enamel (see Appendix 2), for example the mount from the Micklebostad and hanging bowl on the Copenhagen shrine (Henry 1965, Pl B; Mahr 1932, Pl 16) (Fig. 22).

STEP PATTERNS

Fig 6.1

SINGLE STEP PATTERNS AND RELATED ORNAMENT

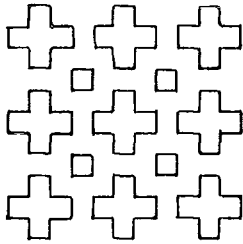

Killamery A1
Kitree C1

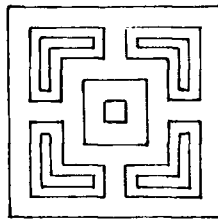

Kilkieran I A2

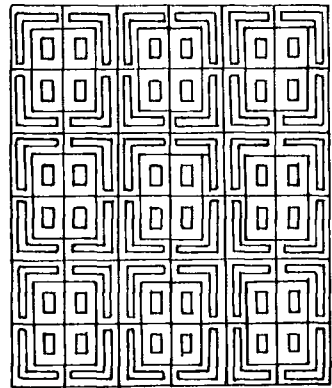

Ahenny IC3



Kilkieran I A1

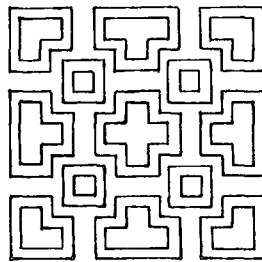

Cashel B2

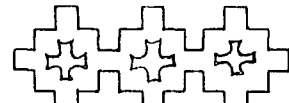

Killamery C8

DOUBLE STEP PATTERNS

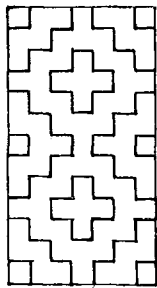

Clonmacnoise II B

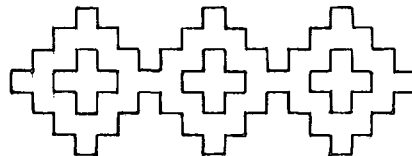

Kitree D8
Mona Incha I D2

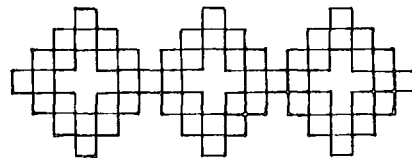

Killamery B8

TRIPLE STEP PATTERNS

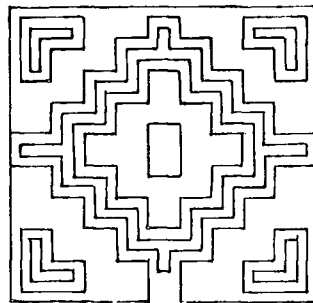

Bealin B2

CHEQUER PATTERNS

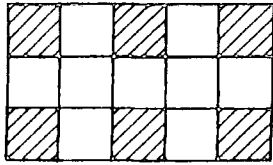

Killamery A 15

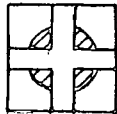

Ahenny I A5, B5, C5, D5

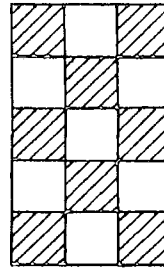

Leggettsrath I D

(See also Kilkieran II B 3)

MISCELLANEOUS PATTERNS

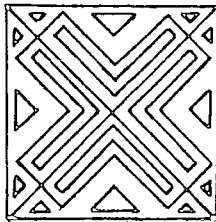

Ahenny I A 4

They are early adopted into the ornamental repertoire of manuscripts being represented in the Book of Durrow, the Lindisfarne Gospels, the Durham Cassiodorus (Durham Cath. Lib. B.II.30) and the Book of Kells (Dublin TCD 58) (Nordenfalk 1977, Pls 2, 15, 28, 43) but at all times their style clearly betrays their metalwork origins. Metalwork of the eleventh and twelfth centuries sees a revival in the popularity of such patterns which are used in cut out form to decorate the backs of shrines, for example the Soicél Molaise and the Shrine of the Stowe Missal (Mahr 1932, Pls 57, 67; Crawford, H.S. 1923, Fig. 2).

In sculpture they are not so common. In Pictland there is only one example on Rosemarkie I where the stepped cross seems to be derived from manuscript ornament (Henderson 1978, 50). Therefore they are not included in Romilly Allen's analysis of ornament. They are equally rare in Anglo-Saxon England, there being one example from Irton in Cumbria (Collingwood 1927, 83, 119). In Ireland there are a number of examples particularly on the crosses at Kilree and Killamery (see p 137).

As one might expect, step patterns are constructed on square grids and Bruce-Mitford (1960a, 223) has found examples of these in the Book of Lindisfarne. Evidence of a grid which has been adapted as an integral part of the pattern may also be seen on Killamery B 8 (see p 137). Patterns of this kind are relatively easy to measure to see if they are constructed with a standard unit measure as this is simply the width of the square. It was discovered in one or two instances, for example Clonmacnoise II (see p 79), that the unit measures were the same for more than one type of pattern, for example step patterns and interlace patterns.

The repertoire of chequer and step patterns is not great. They are catalogued in Fig. 6. The single patterns composed of triangles, Kilkieran II B 3, and the patterns composed of 'L' shaped elements, Ahenny I C 3, may also be included here.

5) Zoomorphic and Anthropomorphic Patterns

The origins of such ornament are complex. There are zoomorphic elements in Irish manuscript art as far back as the possibly late sixth century Cathach of St Columba (Dublin R.I.A.) (Nordenfalk 1947, Fig. 14C) but the real boost to its proliferation seems to have come during the second half of the seventh century with the adoption of Germanic beasts derived from Salin Style II into the repertoire of Hiberno-Saxon manuscript illumination as demonstrated by the St John carpet page in the Book of Durrow (f192) (Nordenfalk 1977, Pl.8). By the time the Lindisfarne

Gospels were illuminated c698-721 zoomorphic ornament had become a characteristic element in Hiberno-Saxon art. Anthropomorphic ornament enters the repertoire slightly later as exemplified in the Book of Kells (see p 71).

There are two sorts of zoomorphic and anthropomorphic pattern. In the first the terminal strands of ordinary interlace patterns, instead of joining together in the normal way, end in zoomorphic or anthropomorphic elements, for example Banagher C 3. Such terminals may also be used in spiral patterns. In the second the pattern is formed by the interlacement of the entire body of a bird, quadruped or man as in Banagher A 3. The actual repertoire of zoomorphic and anthropomorphic elements is very wide and, there being fewer mechanical strictures than in the purely abstract ornament, it is open to a very broad range of interpretations on the part of the artist. For this reason it does not seem practicable to catalogue each pattern here but each motif together with its comparisons is discussed in some detail in the course of the text.

It is easy to see that interlace or spiral patterns with zoomorphic terminals would be constructed along the same lines as ordinary interlace or spiral patterns. However, designs in which the entire body of the creature is interlaced are more problematical. Romilly Allen did not approach this difficulty and unfortunately Bruce-Mitford (1960a, 227-30) was not successful in finding any traces of construction lines for zoomorphic patterns in the Book of Lindisfarne. The majority of work on this was done by George Bain (1951, 104-115) and, although the advice on pattern construction in this book is aimed at the practising artist rather than the student of Hiberno-Saxon art, one must conclude, as Bruce-Mitford did, that his methods provide a likely basis. The constructional methods he suggests are similar to those used in other types of ornament: grids of squares, dots marking strategic points in the pattern and the division of panels using a mixture of ruler and compass, the ornament then being applied freehand. This view is supported by a shale 'motif piece' from Garryduff which shows two incomplete versions of a similar anthropomorphic design (O'Kelly 1962-4, 89-80, Fig. 15, Pl X; O'Meadhra 1979, No. 71, Figs. 377-80). This design was constructed in the following manner. Firstly, a rectangular frame was lightly incised using freehand strokes and this was divided into four also using freehand. Compass drawn curves were then placed at strategic points to aid construction. The design was then drawn

freehand very lightly taking no notice of the correct under and over of the individual interlace elements. Finally these light lines were deepened and the interlace crossings were correctly arranged. Unfortunately the zoomorphic and anthropomorphic patterns on the crosses of Offaly, Kilkenny and Tipperary have yielded no indications of how they were constructed but one suspects that techniques similar to those outlined above would have been used.

* * * * *



Having discussed at some length the repertoire of ornament and the way in which it was constructed one should now ask how such ornament was actually applied to the stone. If complex ornament is to be competently carried out there must be some kind of preliminary stage, possibly a pattern book, or perhaps the design was simply sketched out on a 'motif piece' of stone, bone, wood or vellum. Once the pattern had been decided on it had to be transferred on to the roughed out panel on the cross.⁷ In many instances a grid could have been applied to the stone with chalk and then the pattern drawn freehand. However, this does not account for the fact that certain monuments or groups of monuments seem to favour grids of certain size. Recently Richard Bailey (1978b, 179ff; 1980, 246-53) argued convincingly that templates had been used as the basis for motives on a variety of Anglo-Scandinavian sculpture in South Durham and North Yorkshire. A template used to produce a motif on one monument could be used to produce the same motif again on another. He has also carried out a detailed examination of the Durham Cassiodorus (Durham Cath. Lib. B.II.30) and suggested that the two figures of David, which are quite clearly by different artists, were constructed with the aid of the same templates (1979, 14-7). In this case the entire design was not drawn with a single template but certain curves on each of the figures are the same and could have been reproduced with the aid of a template working rather like a French curve. Gwenda Adcock (1974, p 39) has suggested that a template made of lead used for drawing out interlace may still be in existence, having been excavated at Monkwearmouth although Rosemary Cramp (1970, 329, Pl LIV f) has suggested that it may have been placed in front of coloured window glass to produce a patterned effect. One suspects, but one cannot at the moment prove, that sculptors in Ireland were also using templates. It is possible, where patterns are identical in size as well as design, for example Bealin

A 3 and Clonmacnoise I A 5 (see pp 52, 54), that a template of the entire pattern might have been produced in sheet metal or leather, used for one monument and then put away until it was needed again. However, what seems most likely at the moment is the idea that just one design element, for example a single interlace knot, might be made up as a template and then, by turning this round in different directions or turning it over, an entire pattern could be constructed. Loose strands could be joined together at the end or others added with the aid of a ruler or a template curve. This method of construction is a possibility on Kinnitty I A 4 (see p 172). Again the template could be stored and then used as necessary elsewhere. One should also consider whether template curves could have been used as in the Durham Cassiodorus. Certainly one might expect the 'S' and 'C' curves on spiral patterns to have been produced in this way although an entire interlace pattern seems unlikely as the method would be very cumbersome.

Undoubtedly the methods of construction and execution of Hiberno-Saxon ornament is a field of research which is developing quickly and one would expect ideas to change rapidly in the next few years. It is possible that the best results may come to light by looking not at sculpture, where the subsequent carving and weather usually destroy any signs there may have been of the original lay out, but at manuscripts or 'motif pieces' where that evidence is likely to be still extant. Bruce Mitford's study (1960a) of the grids in the Lindisfarne Gospels was pioneering for the art of the British Isles and has since been followed up by Gwenda Adcock (1974) in the case of the Durham (Cath. Lib.) A.II.10 and by Richard Bailey for the Durham Cassiodorus (1979, 12-17). Work on other manuscripts along these lines would undoubtedly be profitable. Uainnin O'Meadhra's recent catalogue of Irish 'motif pieces' (1979) shows the potential for telling us a great deal more about construction techniques and how the actual carving was carried out. Some reference has already been made to pieces which show evidence of constructional techniques. The discovery of other 'motif pieces' in future excavation may very well tell us a lot more.

Chapter II. FOOTNOTES

1. For a summary of current thinking on this subject see Edwards 1976.
2. Adcock 1974, 64.
Relationship of Adcock's categorisation to Allen's.

Pattern A:	RA Nos. 653 - 664;	Basic A;	No. 658
Pattern B:	Nos. 524 - 548;	Basic B;	No. 526
Pattern C:	Nos. 632 - 652;	Basic C;	No. 638
Pattern D:	Nos. 589 - 594;	Basic D;	No. 590
Pattern E:	Nos. 595 - 618;	Basic E;	No. 611
Pattern F:	Nos. 549 - 588;	Basic F:	No. 557
3. I am grateful to Robert Stevenson for his very helpful discussion with me of the importance of the cross-symbol in Hiberno-Saxon art.
4. The problem of whether rubbings of the patterns should be taken was carefully considered but rejected because many of the crosses are severely weathered making this difficult. In some instances the patterns were better preserved but the high relief of parts of the monuments, for example bosses and mouldings, again made rubbing difficult.
5. A grammar of spiral elements in use in this period has been drawn up by Fox (1958, xxvii, Figs. 82, 83).
6. This variation (RA No. 880) at first looks rather peculiar but presumably it is arrived at by changing  to .
7. For an example of an unfinished cross at this stage see Kells East (Roe 1966, Pl XIX).

Chapter III. THE ORIGINS AND MORPHOLOGY OF THE FREESTANDING CROSS IN IRELAND.

1) The Prehistoric Period

The stone sculpture of the Early Medieval Period is by no means the first venture into this medium found in Ireland. Indeed, the earliest experiments may be seen during the mid to late Neolithic in the prolific and accomplished carving found in the passage grave art of the Boyne Valley (Herity 1974, 93 ff). The geometric quality of this, as Françoise Henry (1965, 1) has stressed, seems to set the tone for much of the work that followed, both in the Iron Age and in the Early Medieval Period. In the Bronze Age, however, there seems to have been very little stone sculpture. The only class of monument which may perhaps be mentioned is the cup and ring marked stone which is traditionally ascribed to this period (Mac White 1945).

During the Iron Age, with the development of La Tène art in Ireland, three principal types of stone sculpture may be noted. Firstly, there are monumental blocks of stone, the surfaces of which are carved with an intricate carpet of spiral ornament in low relief. The most famous of these is the Turoe Stone, Co Galway, undoubtedly a very accomplished piece, which has generally been considered early, between 500 and 300 B.C. (Raftery J. 1944, 45). However, recently Michael Duignan (1976), in a detailed analysis of the ornament, has concluded that 'the Turoe stone shows us a mixture of insular traditions and styles, and represents an advanced stage of insular La Tène art (op. cit, 210) and, in the light of current opinion (op cit, 214), this would seem to be the more acceptable suggestion. Other stones decorated with spiral ornament have been found at Castlestrange, Co. Roscommon, which Duignan (ibid 215) regards as a 'degenerate' piece of work compared with Turoe, and the Killycluggin stone from Co. Cavan, the ornament on the upper part of which is now missing (Macalister 1922, 113-6). The spiral decoration on these monuments is asymmetrical but ornament of this type may undoubtedly be regarded as the forerunner of the Early Christian spiral patterns (see p 10). In addition there is a little known stone from Mullaghmast, Co. Kildare, now in the National Museum (Coffey 1902-4,

263-66, Pl XXII). This seems to be a late example of this type of monument and is decorated in low relief with a triskele on the top and spiral ornament on two sides resembling early enamelwork. The other two surviving patterns are incised showing a symmetrical pattern of 'S' and 'C' scrolls.

The second type of stone sculpture which evolves during the Irish Iron Age is connected with the cult of the head. As Anne Ross (1967, 149-153) has stated these objects are often very difficult to date because an interest in the head is maintained long after the advent of the Early Christian Period (see p 71). However, the type may be exemplified by the fine tricephalos from Corleck, Co. Cavan (op cit. 108-110).

The third type, the monumental figure, is centred on Northern Ireland with a concentration in the area of Lough Erne. Undoubtedly, the most dramatic of these is the horned figure from Tanderagee but two other important examples have been found on Boa and Lustymore Islands¹ (op cit, 191-3, Pl XI). Again one should point out the retention of this type of sculpture into the Early Christian Period. Such continuity may be seen clearly in the statues from White Island, also in Lough Erne, which carry undoubtedly Christian attributes although their facial and bodily features bear many of the same stylistic details as their Boa and Lustymore Island neighbours (Hickey 1977). Further evidence of continuity may be seen in the figures from Killadeas, Co. Fermanagh and the small shafts from Carndonagh, Co. Donegal (Henry 1967, Pl 9; 1965, Pl 59). Therefore, at the advent of the Early Medieval Period, stone sculpture was not an entirely new medium, one that had to be introduced from outside, but one which had already been experimented with over a long period of time. The evidence of this would, without doubt, have been available for the monastic sculptor to draw upon and the inspiration of these earlier monuments may be inferred in some of the stylistic details of the later material. The Irish sculptor, with the advent of Christianity, does not seem to have tossed away his former pagan artistic vocabulary, but, rather, blended it with a Christian artistic repertoire which was introduced from abroad.

2) The Beginnings of Early Christian Sculpture in Ireland

This is an almost impossibly difficult subject to tackle, especially as it is an area which would benefit from a far more concentrated research effort than it has received in the past (see p 1).

However, it does seem appropriate to (at least) attempt a brief survey of the different classes of sculpture which were current during the Early Medieval Period in Ireland, especially at the beginning, in order to better understand the background to the advent of the freestanding cross form and to see what sources of inspiration may have been available at the time.

The earliest stone monuments in Ireland which have Christian associations are the ogam stones (Macalister 1945). These are undoubtedly commemorative. They are concentrated in the South West and, although they were probably current from the fourth to eighth centuries, they seem chiefly to belong to the fifth and sixth (Jackson 1953, 152-3). These monuments are, however, extremely difficult to date precisely and it is by no means clear whether they are all Christian (Thomas 1971, 96). Despite these uncertainties it seems important to draw attention to the form of these monuments, rough pillars or boulders, the origins of which may lie in the Prehistoric past, while the inscriptions were probably inspired by Roman tombstones (op cit 94, Henry 1965, 56). Such pillars and boulders with the addition of slabs, whether they are shaped and dressed or left entirely rough, provide much of the raw material for Irish sculpture during the Early Medieval Period.

One or two ogam stones, for example Arraglen, Co. Kerry (Macalister 1945, 140²; Hamlin 1972, 26) are ornamented with a small 'monogram' chi-rho³. Others, for example Aglish, Co. Kerry (Henry 1965, Pl 14), are decorated with a small cross. From these humble beginnings, perhaps inspired by such things as the use of crosses and chi-rhos⁴ on imported pottery (Thomas 1971, Fig. 55) or in manuscripts (Lionard 1960-1, 101), the cross form seems to grow rapidly in importance to dominate every aspect of Irish stone sculpture. In this atmosphere the climax is reached by the advent of the freestanding cross, itself a monumental cross symbol.

There are a great variety of pillars, slabs and boulders decorated with variations on the cross theme. They are concentrated on the western seaboard of Ireland, their distribution in the east being very much more restricted (Henry 1965, 137). The purpose of such monuments is not always clear. Some are gravemarkers; others, which stand within some early monastic or ecclesiastical enclosure may have acted as some other focus or demarcation. However, many, which appear to survive in situ, do not seem to be connected with any ecclesiastical remains. This has led to various suggestions. It is possible they could have marked routes or boundaries or perhaps even commemorated some event

(Hamlin 1972, 24). Such monuments have been regarded (Henry 1965, 57, 117ff) as preceding the freestanding cross series. While some are undoubtedly early, for example Reask, Co. Kerry, which is regarded as late sixth or early seventh century on account of its archaic inscription and the elaboration of the cross motif, which dominates the stone, with curvilinear and spiral ornament, which is both reminiscent of the earliest Irish manuscripts and derived from La Tène spiral decoration (Ibid), it seems unwise to assume that all pillars, slabs and boulders decorated with variations on the cross theme are also early. Given the simplicity and crudeness of some of the monuments, the conservative nature of Irish art and the fact that, apart from a few late examples in Clare and Aran (de Paor, L. 1955-6), the freestanding cross is not found in western Ireland, there seems no reason for thinking that the manufacture of pillars, slabs and boulders decorated with crosses might not have continued in the west for a very long time.

During the seventh century the Irish monasteries were establishing themselves as centres of learning (Hughes 1963, 64-5) both at home and abroad. Such foundations as Bobbio must have brought Ireland into far greater contact with the Continent, Iona with Pictland and the importance of Lindisfarne in the innovative cauldron of Northumbria in the seventh and early eighth centuries cannot be over-emphasised. The artistic output of the Irish monasteries in this period is more difficult to gauge but during the eighth century the increasing prosperity of many becomes apparent and with it the establishment of the great Irish scriptoria (Hughes 1958, 249 ff). It seems likely that developments in stone sculpture, leading ultimately to the advent of the freestanding cross, would also have come about in this atmosphere.

Françoise Henry has remarked (1965, 118) that two different classes of stone sculpture seem to evolve. Firstly, there is the recumbent grave slab. According to Lionard (1960-1, 156) this class of monument was first used during the seventh century and it remained important right up until the eleventh. The slabs, which were either placed over the grave or, in the case of some of the smaller examples, within the grave fill, are dominated by the form of the cross, the stone sometimes being elaborated further by the name of the person commemorated or some other short inscription. This class of monument never reaches beyond the fairly routine standard of artistic achievement (see Appendix 3), and, most important, it is always two dimensional. However,

concentrations undoubtedly act as indicators of monasteries, Clonmacnoise for example (Macalister 1909), where a stone mason's yard was one of the standard monastic workshops and it was surely where such facilities were already available that there would be room to experiment with more ambitious sculptural projects. Charles Thomas (1971, 124-5) views the similar 'primary' grave slabs and markers found on the western seaboard of Britain as a feature of the Irish monastic church abroad and further Irish evidence may perhaps also be seen in the Northumbrian monasteries (Brown 1921, V, 59 ff; Collingwood 1927, 10ff; Lionard 1960-1, 130-1) although, in this instance, Continental influence may also be an important factor (Cramp 1965, 2).

The second class of monument Françoise Henry (1965, 118 ff) discusses is the upright slab or pillar which assumes an increasing monumentality and elaborateness. In her attempt to establish this very diverse group of monuments as the direct antecedents of the freestanding cross, she has sought to date them all to the late seventh and early eighth centuries. She has noted two main groups. The first has incised ornament, some figural, and includes the monuments at Kilnasaggart, Co. Armagh, Kilaghtee, Co. Donegal, Iniskea North and Duvillaun, Co. Mayo, the Innismurray slabs with interlace crosses, Co. Sligo, Killeen Cormac, Co. Kildare and Ballyvourney, Co. Cork. The second group consists of monuments in low relief: Glendalough, Co. Wicklow, Gallen Priory I, Co. Offaly (see p 264) and Fahan Mura, Drumhallagh, Carndonagh and Iniskeel, Co. Donegal.

The problems of dating these monuments, and indeed the difficulty of whether they form any real coherent group, may be illustrated on several counts. For example widely differing views have been expressed as to the date of the monuments at Fahan Mura and Carndonagh. Françoise Henry (1930a, 95; 1940, 59) sees these as belonging to the second half of the seventh century on the grounds that the broad band interlacing may be compared with the Book of Durrow. In agreement with this Carl Nordenfalk (1947, 170) has added a comparison with the interlace in Durham A. II.10 and this early date has also been supported by Macalister's reading (1929, 89ff; Henry 1965, 126-7) of the inscription on Fahan Mura which seems to give a terminus postquem of 633. In contrast Robert Stevenson (1956, 93-6) believes the monuments to be much later, indeed of the Viking period, on account of their resemblance to the slab from Ardchattan, Argyle, which shows bifurcation of some of the interlace strands and the use of pellets in the interlace mesh. These are supposedly Viking features which Fahan Mura and

Carndonagh do not display. However, in the case of Fahan Mura Henry's and Nordenfalk's comparisons of the broadband interlace with the Book of Durrow and Durham A.II.10 seem entirely reasonable and, in addition, quite close comparisons may be made with the early class II Pictish slabs. The shape of Fahan Mura with its gabled top is very similar to this group and it is almost identical in height to Glamis II (Allen and Anderson 1903, III, 221). Both Fahan Mura and the Pictish slabs are dominated by the form of the cross decorated with abstract ornament, although with the latter this is only found on the front of the monument. Both are carved in low relief with incised lines to bring out the detail. On one side of the Fahan Mura slab (Henry 1965, Pl. 52) traces of wheel arcs may be seen beneath the horizontal cross arms. Such tentative indications of the wheelhead may also be seen on Glamis II. Therefore the Fahan Mura slab would seem to fit into the late seventh or early eighth century context into which Françoise Henry first placed it, although, in view of its similarities with the Pictish monuments, it could be slightly later.

In contrast with the Fahan Mura slab the monument at Carndonagh, in the shape of a freestanding cross (Henry 1965, 128-131, Fig. 16), is a much less accomplished piece of work. The contour lines characteristic of the Book of Durrow interlace are not included, the slab shape has been abandoned in favour of a crude freestanding cross and the Crucifixion scene has much in common with the granite crosses of the Barrow Valley (see p 188). Judith Calvert (1977), while believing the Fahan Mura slab is early, suggests the Carndonagh monument may be as late as the tenth century. The dating she gives may be too precise, but that the Carndonagh cross is considerably later seems very likely.

This example illustrates clearly the problems of regarding these monuments as a well defined group of approximately the same date. In addition, Gallen Priory I (see p 267) may well be contemporary with the early Clonmacnoise shafts and the cross at Bealin. It would also be surprising if the crude Crucifixion on the slabs from Duvillaun and Iniskea North (Henry 1937, 272-3, Pls XXI, XXIV.1) are as early as the late seventh or early eighth century since both show Christ either naked or clothed in a loin cloth. The earliest example of the revival of the Crucifixion type with Christ in a loin cloth is the Sacramentary of Gellone, admittedly a manuscript with strong Hiberno-Saxon ornamental influence, which may be dated to the third quarter of the eighth century (Schiller 1972, 102, Fig. 349). Otherwise the robed

Christ is almost ubiquitous before the ninth century (Coatsworth 1979, 177ff).

While it is true that these monuments are linked by their slab or pillar shape and incised or low relief ornament, they otherwise display great variety and the comparative simplicity of many of them may not necessarily mean they are all early. They also appear to cluster in the North West of Ireland, an area where the slab form may have been favoured if the stone was unsuitable for more three dimensional sculpture, and therefore it would again seem unwise to regard this group as approximately contemporary. Indeed the only monument in this group which can be dated with any certainty at all is the Kilnasaggart Pillar. This shows the survival of a pillar with inscription and relatively simple cross ornament at least until the period around 700 (Henry 1965, 119; Macalister 1949, 114).

From this brief discussion it may be seen that the monuments which Françoise Henry regards as the direct antecedents of the freestanding cross are perhaps not such a coherent group as has been thought in the past. Some, like Fahan Mura and Kilnasaggart, are likely to be early; with some of the others an early date is far more questionable. In this light the immediate forerunners of the free-standing cross form in Ireland become fewer and much more difficult to identify. Indeed, there is a tremendous leap between the cross marked slabs, pillars and recumbent grave markers, mostly comparatively simple, and the monumental freestanding cross with its great range of abstract ornament and iconography.

A related skill which may have influenced Irish monumental stone carving is the art of building churches in stone but this too is a subject fraught with difficulty. Such buildings, because of their simple plan, are extremely problematical to date (Leask 1955, 1). It had been thought that stone churches might be found in the west of Ireland from an early period (op cit, 17 ff) but Peter Harbison (1970), in his study of the Gallarus oratory, Co. Kerry, has called this into question and suggested that the earliest Irish stone churches may be those which display wooden skeuomorphic features and which begin to become common c900 (op cit. 58).

Whatever the date of their inception, one important thing to notice is that, in contrast with the early stone churches of Northumbria (Cramp 1965, 2ff), there is very little architectural carving on Irish stone churches of the pre-Romanesque period. What there is does not, on the whole, seem very ambitious, being confined to gable finials

carved with a simple figure or abstract motif (Leask 1955, Fig. 20; Harbison 1970, Fig. 18) and door lintels incised with a cross symbol. The only other possibly architectural sculptures which have up to now been recognised are the mysterious White Island figures. Helen Hickey (1977, 15) noticed that these have sockets on the top and therefore could have had a function as supporting pillars or caryatids, possibly for a pulpit. This lack of architectural stone sculpture may be a significant lacuna considering the important position which Northumbrian architectural sculpture holds in the development of monumental stone carving in Anglo-Saxon England (Cramp 1965).

However, the really great unknown in the early development of Irish stone sculpture is the role of the woodcarver and what influences his craft may have had on the medium of stone. It is impossible to gauge the number of wooden slabs, pillars, grave markers and indeed freestanding crosses which may once have existed and one may only hint at the original importance of this medium. The Ballinderry gaming board is almost the only carved wooden object to survive from the Early Medieval Period (Hencken 1935-7, 175-90, Pl. XXV). Otherwise one is reliant on skeumorphic details such as the gable finials on stone churches. The use of incised line decoration on stone, a technique well suited to wood, as may be demonstrated by the carving on St. Cuthbert's coffin (Battiscombe 1956, 280), also points towards the craft of the woodcarver. A good example of this is the incised figure on the Kileen Cormac Pillar, Co. Kildare (Henry 1965, Pl. IV). Early literature also suggests the importance of woodcarving in Ireland in the form of the much quoted passage describing the church at Kildare, in the seventh century Life of Brigit by Cogitosus. He says the church, which is almost certainly of wood, has an 'ornatam portam' (Migne 1844-64, LXXII, col. 789), thus implying that it may have been carved. A further indication of the decoration of wooden churches with carving is provided by the Life of St. Maedóc.⁵ Here it is recorded that the church at Ferns was decorated with

'wondrous carvings and brave ornaments'

'go ndealbhadhaibh iongantachaibh

to ngresaibh bregha'

(Plummer 1922, I, 188, para. 34; II, 182; Murray 1979, 85)

From this short discussion it is possible to see the sculptural background which led up to the advent of the freestanding cross and also to note the apparent lack of monumental antecedents in the areas

where crosses became a characteristic feature of the monastic landscape. It now remains to examine the origins of the freestanding cross itself.

3) The Development of the Freestanding Cross in Ireland

This is a very difficult question which in the past has given rise to considerable controversy, discussion and speculation. It seems unlikely that it will ever be solved satisfactorily. However, it is necessary at this point to try to draw together the various strands of thought on the subject since the bulk of this work is concerned with the earlier examples of the freestanding cross in Ireland. The problem has arisen because the class of monument conveniently known as the 'High' cross, which is found throughout the British Isles in the Early Medieval Period, is virtually unique. The only possible parallels which have been cited (Henry 1965, 132) are fragmentary freestanding shafts, probably dating to the fifth or sixth centuries AD, found at Adiaman, Haritch and Thalia in Armenia⁶ (Baltrušaitis 1929, Pls LXX and LXXI; Stryzygowski 1918, II, Figs. 678-85). This is an area remote from the British Isles and their superficial resemblance is probably purely fortuitous.

Without doubt the origins of the freestanding cross in Ireland may be sought in a number of different factors. Firstly, there is the importance of the cross as a symbol, a sign of Victory. Michael Swanton (1970, 42-52) has shown how the cult of the cross grew from the Constantinian period onwards and how, during the course of the seventh century, it spread rapidly across the West with the increasing popularity of relics and the movement of churchmen. In Anglo-Saxon England the importance of the cross symbol is amply illustrated by the Dream of the Rood and there are also hints of an interest in the cult of the cross amongst the Irish literature. For example they may be traced in Adomnan's descriptions of the veneration of the relics of the Cross in Byzantium in De Locis Sanctis (Meehan 1958, 108-111) and in a poem on the Cross of Christ (Meyer 1904). The freestanding crosses aside there is a preoccupation with the cross symbol in Hiberno-Saxon art in general. It is a recurrent motif in the early Irish sculptural patterns (see pp 8, 15) and it is also extremely important in the manuscript medium. An early example of this may be seen in the Codex Usserianus Primus (Dublin T.C.D. 46. MS.55), a manuscript which is dated to the beginning of the seventh century and which has Irish associations. The only surviving ornament consists of a rectangular panel decorated with a cross with a chi-rho hook, an alpha and an omega (Henry 1950; 1965, 62)

In later manuscripts, the Lindisfarne Gospels for example, the cross symbol dominates many of the carpet pages and in the medium of metal-work there have also been hints at the importance of the cross symbol, (see p 8), for example the cruciform mount on the Moylough belt shrine (O'Kelly 1964, 157-162, Pls. 11 and 14).

The second factor which must be considered is the role that wood carving played in the evolution of the freestanding cross form. This has already been touched upon briefly and it is undoubtedly an important problem. In Adomnan's Life of St. Columba, written probably between 688 and 692, he describes a freestanding cross which had been set up in a millstone and he says that this was still extant in his own day.

'In quo loco postea crux molari infixā lapidi hodieque stans in margine cernitur viae'.

(Anderson A.O. and Anderson M.O. 1961, 522-3).

As Collingwood has commented,

'Now a cross that would stand in a quern must have been a slender thing of wood' (1927, 5).⁷

and from this it may be seen that the freestanding wooden cross was in existence by the late seventh century in Iona and probably for some time before. As Bede tells us, in Northumbria a freestanding wooden cross was set up by Oswald in 633 before the Battle of Heavenfield:

'Denique fertur quia facta citato opere cruce, ac fouea praeparata in quia statui deberet, ipse fide feruens hanc arripuerit ac foueae imposuerit atque utraque manu erectari tenuerit, donec adgesto a militibus puluere terrae figeretur'.

(Colgrave and Mynors 1969, 214-5)⁸

In this act it is possible that Oswald was influenced by the Iona practice of erecting wooden crosses as he had himself spent time at Iona.

The impetus for these freestanding wooden crosses could have come ultimately from the east. For example in De Locis Sanctis Adomnan mentions a 'tall wooden cross' which had been erected in the spot where Christ was baptized:

'in eodem sacrasancto loco lignea crux summa infixā est'

(Meehan 1958, 86-7).

Charles Thomas (1971, 118, Fig. 57) has also suggested very persuasively that incised crosses, which are found on primary cross slabs from Ardwall Isle, the Holm of Noss, Shetland, and Staplegorton, Dumfries⁹,

are a skeuomorphic depiction of a simple wooden cross made up of two wooden slats joined together at right angles to each other. Thomas (op cit, 123) sees such simple wooden crosses being placed on, in or at graves from the seventh century onwards. In Ireland an extension of this idea may possibly be recognised on recumbent grave slabs which show incised crosses with spikes on the end which suggest they were intended to be driven into the ground (Macalister 1909, Figs. 25, 29, 87, 96, 97, 103, 112, 118; Collingwood 1927, 11).¹⁰ The most important of these is a slab from Clonmacnoise with the inscription 'OR AR CHUINDULESS' which has been linked, without much confidence, with the abbot who died 720-4 (Macalister 1909, 101; Lionard 1960-1, 157). This cross has a wheelhead, and therefore, if the dating is correct, it suggests that freestanding wooden crosses with wheelheads were known at this time (O'Riórdáin, S.P. 1947, 111). However, it would be a very early example of the wheelhead cross on recumbent grave slabs of a type which seems to be current during the ninth century (Lionard 1960-1, 126-7, 156). Whether this early date is acceptable or not, it does seem likely that the crosses with spikes on recumbent graveslabs are skeuomorphic of wooden freestanding crosses, some of which would have had wheelheads.

The likely existence of wooden freestanding crosses, perhaps forerunners of their stone counterparts, is suggested in Robert Stevenson's (1956, 85-9) important article which shows that the Iona crosses were constructed of several pieces of stone linked by mortice and tenon joints. At Iona a considerable amount of experimentation seems to have gone on using carpentry techniques to produce stone crosses, both with and without rings and, in the case of St. Martin's Cross, the slots at the ends of the horizontal cross arms may have been made to receive extensions which could have been of wood or metal rather than stone (Robertson 1974-5, 115-7). The use of carpentry techniques in the production of these stone monuments seems of the greatest importance in attempting to evaluate the contribution which wood carving and carpentry offered to the evolution of the freestanding cross of stone.

The third factor to consider is the role of metalwork crosses. Their probable importance immediately springs to mind when looking at the crosses of the Ossory group, particularly Ahenny I and II (see Ch. V), which have the striking appearance of being metal crosses cast in stone. It seems very likely that the origins of these may be traced in the crux gemmata the cross which was set up by Theodosius on the site of Calvary in Jerusalem in 417 and which was later encased

in gold and jewels (Swanton 1970, 44). Indeed a copy of this survives on the late fourth or early fifth century apse mosaic in Santa Pudenziana in Rome which shows Christ enthroned against a Jerusalem skyline dominated by the cross encrusted with gems (Gough 1973, Fig. 69), a possible source of inspiration for any pilgrim in Rome. Adomnan also records a cross on the site of Calvary in De Locis Sanctis. However, by the time Arculf saw it in the early 680's the original may have been replaced by a version in silver:

'Alia uero pergrandis ecclesia orientem uersus in illo fabricata loco qui Ebraicae Golgotha uocitatur; cuius in superioribus grandis quaedam aera cum lampadibus rota in finibus pendit, infra quam magna argentea crux infixata statua est eodem in loco ubi quondam lignea crux in qua passus est humani generis saluator infix stetit.'¹¹ (Meehan 1958, 48-9)

In Britain far more information about the popularity of metalwork crosses comes from Anglo-Saxon England than from Ireland but a glance at the Anglo-Saxon material does perhaps give some indication of what may have been available in Ireland in the same period. For example Bede describes the use of processional crosses. When St. Augustine and his monks met King Ethelbert in 597 they came 'crucem pro uexillo argenteam' (Colgrave and Mynors 1969, 74-5) and in 633, when Paulinus returned to Kent, amongst the treasure he brought was a 'Crucem Magnam auream' (Ibid, 204-5). A cross from Bischofshofen in Austria, which has a wooden core covered in gilt copper sheets and decorated with bosses and glass settings, may be Anglo-Saxon and is dateable to the second half of the eighth century (Lasko 1971, 124-5; Harbison 1978, 283-6). The popularity of pectoral crosses during the seventh century may be exemplified by that of St. Cuthbert which has some particularly Hiberno-Saxon features (Battiscombe 1956, 306-325). It is also possible to see metalwork features translated into stone on Hexham I ('Acca's' Cross) (Cramp 1974, 129, 135).

In Ireland the use of a processional cross with a wheelhead, made of wood or metal or perhaps a combination of the two may be seen at the front of the procession on Ahenny I B 9. (see pl18), but no actual metalwork crosses have survived until the Cross of Cong in the twelfth century (Henry 1970, 106ff). Helen Roe (1965, 222-3) has suggested the influence of the crux gemmata on some of the Donegal slabs, particularly the west face of the slab at Drumhallagh. She has also put forward an interesting hypothesis that the crux florida may

well have been the ultimate inspiration of stone crosses with abstract ornament, the classical motives being transformed to suit Hiberno-Saxon taste.¹² Small metalwork crosses are easily portable and there is every likelihood that examples would have reached Ireland from abroad in this period to act as sources of inspiration.

A fourth factor which should at least be mentioned is the role Northumbria and Pictland may have played in the transmission of the freestanding stone cross to Ireland. Rosemary Cramp (1965, 5) has argued for 'a parallel development, inspired in both areas perhaps from the Middle East'. This may be so but perhaps one should also speculate as to where the knowledge of working large freestanding monuments in stone in Ireland came from. As Bede tells us in the Historia Abbatum and as the Anonymous Life of Ceolfrith also states (King 1963, 400-3) Benedict Biscop, when founding the monastery at Monkwearmouth in 674, had to seek the assistance of Gaulish stone masons and, as Rosemary Cramp (1965) has shown, it is from this period that the early Northumbrian architectural stone sculpture stems. As has already been mentioned there is a distinct absence in our knowledge concerning the early development of Irish stone architecture and also the comparative lack of complex monumental stone carving which can be proved to predate the advent of the freestanding cross. It may be dangerous to argue from negative evidence but one should perhaps speculate as to whether the knowledge of working large blocks of stone could have been transmitted from Northumbria, perhaps via Pictland and Dalriada, to Ireland. After all Bede tells us that architectural expertise to build a stone church 'according to the Roman manner' was requested from Abbot Ceolfrith by King Nechtan of the Picts (Colgrave and Mynors 1969, 532-3).

In addition, perhaps the possible experimentation with various forms of stone cross at Iona alluded to by Robert Stevenson (1956, 85-9) should also be considered in this light, especially as a number of features on them have close Northumbrian comparisons. In the early Northumbrian crosses, particularly Hexham I, Bewcastle and Ruthwell, the vine-scroll and the Scriptural iconography clearly do not spring from an insular milieu. The closest parallels for the Hexham vine-scroll are in the Middle East (Cramp 1974, 135) and it has even been suggested that it is the work of an Eastern craftsman. The figural scenes on Bewcastle and Ruthwell would also seem to spring from a Mediterranean background (Saxl 1943, 7-15). This suggests an atmosphere of innovation in Northumbria and seems to provide a clear

contrast with the Hiberno-Saxon material, both Pictish and Irish, where the accent is on the adaptation of indigenous ornament both from metalwork and manuscripts to a new art form. Iconography is at first sparingly used and vine-scroll is rare. The combination of the fact that in Northumbria it was known how to quarry and fashion large blocks of stone and the innovative ornamental repertoire would tend to suggest that Northumbria may have been the initiator, the Celtic west the receiver.

Having examined briefly the various factors which may have conspired to produce the advent of the freestanding stone cross in Ireland it now seems apposite to discuss the origins of two specific features of the high cross form, the wheelhead and the capstone.

4) Origins of the Wheelhead

The wheel, or Celtic ring head as it is often called, is the most characteristic feature of the Irish cross. The term describes the practise of linking the arms of the cross with arcs of a circle and this feature is almost universal amongst the Irish crosses.¹³ It is also characteristic of Manx, Welsh and Cornish sculpture and is frequently used in Scotland. In the Viking period it is also adopted in England (Collingwood 1926).

The ultimate origins of the wheel have already been discussed in some detail by Helen Roe (1965, 213ff). She rightly dismisses the widely held view (e.g. Coffey 1910, 86) that the wheelhead has either any solar connections or an origin in the Prehistoric past. A far more tenable suggestion was made by Romilly Allen (1887, 92) who thought the wheelhead might be derived from the sacred chi-rho monogram which is frequently enclosed in a victory wreath (Gough 1973, Pl 91) and he went on to connect it with the idea of Eternity. In addition Helen Roe (1965, 217-224) has shown that the Celtic wheel may have its ultimate origins in the Roman triumph where a portrait of the victorious general encircled by a garland of bay was displayed on a shield which was affixed to his standard. This may be translated into Christian terms as the Scutum Fidei or Shield of Faith where the chi-rho, cross, or occasionally a portrait of Christ, are shown encircled and sometimes affixed to a cruciform 'standard'. A particularly good example of this is to be found on one of the pilgrim flasks from Bobbio (op cit, Fig. 7.2). Small portable objects of this kind could well have provided suitable models in the Celtic West.

The encircled cross and chi-rho make their appearance in the British Isles at an early date. There is a sherd of pottery probably imported from the Mediterranean from Dinas Emrys, Gwynedd, which may be reconstructed to show an encircled monogram chi-rho with an alpha and omega and a sun and moon (Savory 1960, 61-2, Pl VIIIb; Thomas 1971, Fig. 55). There are examples of encircled monogram chi-rhos in early sculpture both on the Western seaboard of Britain and the West coast of Ireland (Hamlin 1972, Fig. 3) and incised encircled crosses are also found on many pillars (e.g. Macalister 1945, II; Kermodé 1910, Nos. 25, 27, 117¹⁴). Thus the ultimate origin of the Celtic wheel head seems reasonably clear.

However, the question remains as to why it was adopted on the freestanding cross in Ireland. It does not seem to have been in general use on the recumbent grave slabs until the ninth century (Lionard 1960-1, 156). It is possible that some symbolic reason played a part but, from the structural point of view, S.P. Ó Riordáin (1947, 113-4) may have been on the right track when he suggests that with wooden crosses the attachment of struts to form a kind of wheel may have solved the problem of how to attach the transom of the cross firmly to the shaft. However, the examples he cites of this being translated into stone and shown on recumbent graveslabs from Inis Cealtra (op cit. Fig. 4) are not very helpful since these are both late and atypical of their kind. A better example is perhaps provided by the freestanding crosses from Iona. Robert Stevenson (1956, 85-9) showed both that the Ionan sculptors were using carpentry techniques in the assembly of these monuments and that the Celtic ring was not yet an essential feature. From Stevenson's reconstruction (op cit, Fig. 1) it may be seen that St. Oran's cross, which is ringless, is a very top heavy construction which would have been unlikely to have remained standing very long. The inclusion of the wheel arcs on St. John's cross help to spread the load considerably and a close study of this cross has recently revealed (Personal Communication, Ian Fisher, August 1980) that it may originally have been constructed without a wheel but it fell down and so on its re-erection wheel arcs were added to strengthen the structure. St. Martin's Cross and the cross at Kildalton, Islay (Allen and Anderson 1903, III, Fig. 410), are monolithic, the wheel arcs being an integral part of the original design. It may be noted also that the crossheads of St. John's and Kildalton, although they are identical in shape to the Northumbrian crosses with the addition of the wheel arcs, are very different in overall proportions. For example the Ruthwell cross has a very much

longer, more robust shaft and a very much smaller crosshead than either St. John's or Kildalton where the shaft is quite short and the width across the horizontal cross arms considerable. Thus the inclusion of wheel arcs on the crosses at Iona may have been an important factor in achieving the overall stability of these large freestanding stone monuments. The wheel may have been adopted in Ireland to answer a similar problem.

Where the Celtic wheel evolved seems an insuperable problem. Robert Stevenson (1956, 89) has gone on to speculate as to whether the Ionan sculptors could have borrowed the wheel from their Pictish counterparts. It is true that the early Pictish Class II slabs show a rather ambivalent attitude towards the wheel,¹⁵ which is shown as cusped rather than truly circular, but in Ireland a similar attitude seems to prevail on the Fahan Mura slab where one face has no wheel while traces of two wheel arcs only may be seen on the other (Henry 1965, Pls. 54, 52).

Finally, a word should be said on the origin of the circular rolls which appear on many of the Irish crosses, either on the crosshead at the intersections of the cross arms or at the centre of each wheel arc. Helen Roe (1965, 224) is of the opinion that these are 'a last reminiscence of the star-filled cosmos' as represented by the cross set against the starry heavens in the mosaic at S. Apollinare in Classe in Ravenna. This seems to be taking things too far, although the more general influence of the crux gemmata cannot be ruled out. However, a more likely origin in the metalwork crosses nearer home may be seen on St. Cuthbert's Pectoral Cross (Battiscombe 1956, Pl. XV) which has small semi-circular cusps at the intersections of the cross arms, and also on the altar crosses from St. Denis (Elbern 1965, 120-4). In Ireland identical cusps or rolls are a relatively common feature amongst the Northern 'Scripture' crosses, for example Kells South (Roe 1966, Pl. II). On some 'Scripture' crosses, Clonmacnoise V and Durrow I for example, these rolls are placed on the wheel arcs, possibly because on monuments where the emphasis was on figural iconography the design was improved by their movement. One could also speculate as to whether there is any connection between these rolls and the bosses on the cross arms of many of the Midland crosses, the Ossory group for example.

In addition the use of rolls or cusps may be noted in Pictish sculpture. The quadrilobate ring on the early Class II slabs may be an enlarged version of the cusps on St. Cuthbert's cross (Stevenson

1956, 89). On Aberlemno III these cusps have been raised into bosses with the addition of a Celtic wheel (Allen and Anderson 1903, III, Pl. 228A). On Cossins (op cit, Pl. 230A) there are small circular cusps at the intersections of the cross arms very much in the manner of Kells South.

5) Origins of the Capstone

On Irish crosses which have survived intact the capstone, either placed on top of the upper cross arm, or sometimes, actually part of it, is a characteristic feature. Amongst freestanding crosses it appears to be essentially Irish, the only exception being St. John's Cross, Iona, which has a small rectangular capstone decorated with animal ornament (Robertson 1974-5, Pl. 11).

There are three different types of capstone to be found amongst the Irish monuments. The first, a conical shape, is characteristic of the Ossory crosses. There is some doubt about its authenticity and its origins, if original, remain completely obscure (see p 96). The second and third types are linked. The second is a small roof shaped capstone affixed to the top cross arm by means of a mortice and tenon joint. Examples of this may be found on Clonmacnoise IV and Killamery and amongst the late crosses of Co. Clare, which on the whole do not have capstones, at Dysert o Dea (Henry 1970, Pl. 60). The ornament of the top cross arm is not linked with that of the capstone. The third type, a house-shaped capstone is found on the 'Scripture' crosses. Sometimes this stone is mounted on the top cross arm which has been considerably shortened in order that the heavy capstone should be secure. A good example of this is provided by Monasterboice South (Henry 1967, Pl. 83). In other cases, for example Clonmacnoise V and Durrow I, the effect of a house-shaped capstone is maintained but it is not actually separate from the top cross arm.

There are a number of areas in which the origins of the roof and house-shaped capstones may be sought. Firstly, some of the Pictish Class II slabs, Nigg, Aberlemno II and Glamis II (Allen and Anderson 1903, III, Figs. 72, 227A, 334A) have a gable shaped top to the stone and the slab at Fahan Mura, Co. Donegal, is also of this shape. In addition one of the crosses on the Fahan Mura slab has a roof-shaped capstone (Henry 1965, Pl. 52). The background to these features may well lie, as Françoise Henry (op cit, 126) suggested, in the grave slabs of Continental Europe or possibly Coptic Egypt. For example, the seventh century tomb of Boethius at Verasco in Italy shows a jewelled cross

surmounted by a house shaped feature, the roof being adorned with rosettes while the commemorative inscription is placed beneath (Baum 1937, Pl. LXXII). A number of Coptic stele also have gable shaped roofs, for example the tombstone of Rhodia now in Berlin (Beckwith 1963, Pl. 114¹⁶). It seems possible that the roof-shaped capstones on Clonmacnoise IV and Killamery could be three dimensional versions of the cap on the Fahan Mura cross-slab.

Secondly, Helen Roe (1965, 223-4) has suggested that 'the house-cap with ornate roof, gables and sides [is] the simulacrum of the Holy Sepulchre'. This seems somewhat of an overstatement but the Anastasis which Constantine built over the Holy Sepulchre in Jerusalem undoubtedly acted as a model for the ornament of many different kinds of portable object, for example the ampullae which found their way to Bobbio (Grabar 1958, 42). On these, because the representation is two-dimensional, the circularity of the original monument is lost and the impression is of a small house. The Anastasis may also have influenced the development of the house-shaped reliquary shrines which became so popular amongst Irish ecclesiastical metalworkers. It is these metal house shrines which, translated into stone and complete with ornamented gable finials, obviously influence the capstones on crosses such as Monasterboice South (Thomas 1971, Pl. II).

Lastly, from a purely practical point of view, the sloping faces of the roof or house-shaped capstones may have enabled rain water to run away more freely from the tops of the monuments.

6) The Purpose of the Crosses

First and foremost these large freestanding crosses must have stood out as a symbol to the Glory of God and as a physical sign of the Christian life of the monastery. Otherwise they may have been erected for a number of reasons and it is probable that a single monument could have fulfilled several different purposes.

Firstly, the position of the cross may have been important. The crosses which survive in situ are always aligned fairly precisely with the broad faces orientated West/East. Certain figural representations, particularly the Crucifixion (see p210), are always found on the same side of the cross.

It is known from the written sources that crosses were dotted around the monastery, apparently both inside and outside the monastic enclosure. A cross at the monastery of Slane is described as being 'on the green' (AFM, 848) and another at Tallayght as

'in front of the enclosure'.¹⁷ Baldwin Brown (1921, 156) mentions several other examples of crosses being placed before the door of a house or at the gate of a monastery or by a church. A reference in the Life of St. Comgall simply says the cross was in the western part of the monastery (Plummer 1910, II, 4). This is also backed up by the archaeological evidence. Crosses at Clonmacnoise, Castlekieran (Lawlor 1897, 175) and Ferns (Conway 1975, 105) are dotted about the monastic enclosure; others such as the Market Cross, Kells and Kilree (see p133) are situated a little way away from the modern focus of the monastic remains and an early seventeenth century plan of Armagh shows a cross beside the entrance immediately outside the inner enclosure (Henry 1967, Fig. 2).

There has been considerable discussion (Lawlor 1894-5, 36ff; 1897, 167ff; Stokes, M.M. 1898, XII-XIII; Henry 1965, 134-5; Hughes 1966, 148-9) as to whether a diagram in the ninth century Book of Mulling (Dublin TCD 60, f94V) actually represents the plan of a monastery showing the positions of crosses. (A copy of the diagram together with transcriptions of the lettering and a translation will be found in Appendix 1.) It has even been suggested (Lawlor 1894-5, 42-3) that the diagram could be a plan of the monastery of St. Mullins itself and that the cross at St. Mullins is the 'Cross of Christ and the Apostles' mentioned on the 'plan' (Stokes, M.M. 1898, XIII). Even though the cross at St. Mullins probably shows the twelve Apostles (see p190) this can only be speculation as the 'plan' cannot possibly be related to the extant archaeological remains at St. Mullins. But the idea that some more general monastic plan may be intended is undoubtedly a possibility. The reason for this is that each of the crosses outside the double circle is related to a point of the compass. It seems less likely that these would have been included if the diagram had not been intended to relate to something on the ground. However, it is also a possibility that this diagram could have a liturgical meaning. On the upper part of the page (Lawlor 1897, 161) there seems to be a directory for what should be included in the daily monastic office. On the diagram below the crosses outside the double circle, which are named after the four Evangelists and the four major Old Testament Prophets, may also have a connection with a prayer of Colgá Ua Duinchda in the Yellow Book of Lecan (T.C.D. H.2.16, col. 336). Lawlor (1894-5, 40-1) says that, although this manuscript is fourteenth century, the prayer is much older. The prayer is an invocation to the

four Evangelists and the same four Prophets (Plummer 1925, 31). This could suggest that the circular device is also some kind of diagrammatic invocation but it could also, as Lawlor (1894-5, 40-1) suggests, relate to the monastic 'plan' suggesting that these crosses are protective.

Certainly, the idea that crosses gave some kind of protection against evil is found several times amongst the source material and may have been one of the main reasons for erecting them. For example, the poem about Oengus included immediately after the Féilire Oengusso (see p 122) in the Lebar Brecc (R.I.A.) says:-

2. Dísert Bethech a mbói in fer
 gus ticdis airrdi [leg. airbri] aingel,
 cathair credlach iar cuairt cross
 a mbid mac Oiblen Aengos.

Dísert Bethech wherein dwelt the man
 whom hosts of angels used to visit,
 a pious cloister behind a circle of crosses,
 wherein Oengus son of Oiblén used to be.

* * *

4. Is a Cluain Eidnech ro alt
 hi Clúain Eidnech ro adnacht
 hi Clúain Eidnech ilar cross
 ro lég a salmu ar tuoss.

'Tis in Cluain Eidnech he was reared:
 in Cluain Eidnech he was buried:
 in Cluain Eidnech of many crosses
 he studied his psalms at first.

(Stokes, W.1905b, XXIV-V)

In more practical terms this concept of protection may be linked with the idea of sanctuary. It is known that each monastery had an inviolable area or precinct called a térmon and, according to seventh century church legislators, this area should be clearly marked out by crosses (Hughes 1966, 148; Lucas 1967, 183ff). This is strongly supported by two references to térmon crosses at Clonmacnoise (see p202) and in the second example the cross undoubtedly indicates a place of sanctuary. Therefore, it seems likely that many of the Irish crosses may have acted as térmon or boundary crosses demarcating area of sanctuary. Unfortunately it is not now possible to recognise any of

these crosses in the field with certainty.¹⁸

Secondly, it is likely that some crosses may have had a liturgical use. The difficulty is that there is no real evidence for this and so it is impossible to do anything more than speculate on the possibilities. It has been put forward (Henry 1965, 118) that crosses could have acted as a focus for worship and some of the figural scenes on the crosses themselves also suggest some kind of liturgical use. The popularity of the Passion Cycle on some of the 'Scripture' crosses (see p 217) could mean that they might have been involved in some kind of Holy Week ritual. Similarly one wonders whether the popularity of the Help of God symbolic cycle (see p 121) might denote anything to do with either funerary contexts or possibly merely an extension of the idea of protection outlined above.¹⁹ Finally some crosses, for example Templeneiry I-III, still act as a place of pilgrimage and perhaps one should seriously consider how far crosses may have been a focus of attention for pilgrims visiting monasteries, perhaps on a patron saint's day or some other important religious festival, in the Early Medieval Period.²⁰

Stemming from the idea that the figural representations on these crosses may have been part of some liturgical purpose is the concept that they may have been didactic. The best reason for thinking this is provided by Bede when he wrote about Benedict Biscop bringing back pictures from Rome to decorate the church at Monkwearmouth. He says that the purpose of these pictures was:-

'in order that all men which entered the church, even if they might not read, should either look (whatsoever way they turned) upon the gracious countenance of Christ and His saints, though it were but in a picture; or might call to mind a more lively sense of the blessing of the Lord's incarnation, or bearing, as it were before their eyes, the peril of the last judgement might remember more closely to examine themselves.'²¹

(King 1963, 404-7)

Thirdly, crosses are known to have been set up to commemorate either events or persons. Baldwin Brown (1921, 157-61) has listed many different examples from the source material, and although he is right to be wary of accepting these stories without question as they may merely be a way of explaining the history of a monument which was already in existence, they do nevertheless record the types of event which may have merited commemoration with a cross. They may have recorded meetings between saints or miracles and there is also the cross that King Oswald of Northumbria set up after the Battle of Heavenfield (see p 30). On the monuments themselves Clonmacnoise V C 15, Dysert O Dea and Clones have

panels which could show scenes of foundation (see p234) and therefore it is possible that the crosses could have been erected to commemorate an event of this kind. To what extent freestanding crosses may have been funerary is unknown and no excavation has been carried out in Ireland to test the idea although one example is mentioned in the source material (Brown 1921, 160-1). Obviously cross slabs would have been the usual monument for this purpose. However, a funeral procession is actually pictured on Ahenny I B 9 (see p118) and for this reason one would suspect that this monument may be funerary. There is archaeological evidence from Anglo-Saxon England to support this idea, for example Hexham I ('Acca's' Cross) which by repute was in association with a grave (Cramp 1974, 127).

Alternatively, there is definite evidence to suggest that some crosses were set up by churchmen during their own lifetimes. Inscriptions on Bealin A 4 and Monasterboice South (see pp 88, 249) undoubtedly record this. Other crosses seem to be associated with saints. For example, an inscription on Kells South tells us that it is the Cross of Patrick and Columba ('PATRICII ET COLUMBE CRUX') (Macalister 1949, 36-7). It is possible also that, if the circular device in the Book of Mulling is a plan, that the crosses were named after the four Evangelists, four of the Prophets, Christ and His Apostles, etc.

Therefore, freestanding crosses may have served a variety of purposes and it is probable that a single monument could have been used for more than one. Apart from their obvious function as monuments to the Glory of God they could also have marked monastic boundaries or areas of sanctuary, been used in the liturgy or erected to commemorate events or people.

Chapter III. FOOTNOTES

1. It is perhaps interesting to note that both these figures are associated with Christian graveyards (Lowry-Corry 1932-4, 200, 204).
2. Note: Macalister's drawing is inaccurate.
3. A cross with a hook.
4. It is interesting to note that nearly all examples of chi-rhos found on sculpture within the British Isles are on the western seaway routes (Hamlin 1972, Fig. 3).

5. In this context the description of the wooden oratory in the mid seventh century (?) Hisperica Famina should perhaps also be noted. (Herren 1974, 108-9).
6. These shafts are mainly decorated with figural representations. Immediately identifiable are the figures of the Virgin and Child and an Angel on the shaft from Thalin and Daniel in the Lions' Den on the base of a shaft from Haritch. In addition there are some examples of abstract ornament on the bases from both Thalin and Haritch. This includes crosses with expanded terminals, the interstices decorated with a kind of scroll ornament, and simple interlocking devices similar to fret patterns.
7. Collingwood dubs this type of monument a 'staff rod' and sees it as the basis for a number of Northumbrian freestanding stone crosses with circular shafts.
8. Translation: 'In fact it is related that when the cross had been hastily made and the hole dug in which it was to stand, he seized the cross himself in the ardour of his faith, placed it in the hole, and held it upright with both hands until the soldiers had heaped up the earth and fixed in in position.'
9. There is perhaps a further example from Clonmacnoise (Macalister 1909, 36).
10. Many others have features which seem to be derived from such a spike. Macalister 1909, Fig. 33 shows a slab where the cross almost has the appearance of having been stuck in the ground.
11. Translation: 'Towards the east, in the place that is called in Hebrew Golgotha, another very large church has been erected. In the upper regions of this a great round bronze chandelier with lamps is suspended by ropes and underneath it is placed a large cross of silver, erected in the selfsame place where once the wooden cross stood embedded, on which suffered the Saviour of the human race.'
12. This view accords well with R.B.K. Stevenson's suggestion (Personal Communication) that some of the shafts on the crosses on the early Class II Pictish slabs, Meigle I for example (Allen and Anderson 1903, III, Fig. 310A), decorated with interlace roundels springing from a triangular 'root' may be inspired by vine scroll ornament.
13. The wheel has disappeared in some of the late crosses dateable to the first half of the twelfth century, for example Dysert O Dea and the cross from Inis Cealtra, Co. Clare (Henry 1970, 123, 130, Pls. 60, 50). At Cashel the wheel arcs are not present but the horizontal cross arms are supported by a 'crutch' (Leask 1951).
14. Collingwood (1926) sees the Isle of Man as a possible starting point for the wheelhead cross which was then transferred elsewhere within the British Isles along the western seaways. Since cross slabs of this type may now be seen to have an overall western distribution this view may now be discounted.
15. The crossheads on Aberlemno II, Eassie, Meigle I and the front of Rossie have quadrolobate wheels. On Glamis II only two quadrants of the wheel have been carved. On St. Vigeans VII there are spiral terminals rather than a wheel. There is no wheel on Glamis I and

the back of Rossie. (Allen and Anderson 1903, III, Figs. 227A, 231A, 310A, 322A, 234A, 278, 233A, 322B).

16. For other examples see Bober 1967, Figs. 8, 9.
17. This appears in a ninth century tract (R.I.A. MS 3.B.23) describing the traditions of Tallaght and the teachings and practices of its founder Maelruain and his disciple Maeldithruib. 'anacaldaim iarum for aulaid oc cros ind dorus lis' 'and it is right to converse with them (the nuns) standing on the slab in front of the enclosure'.
(Gwynn and Purton 1911-2, 151).
18. There is one possible example at St. Buryan, Cornwall, where a very large number of crosses are dotted about the parish. However, it is equally likely that they could be intended to mark roads and footpaths rather than areas of sanctuary (Personal Communication, Ann Preston-Jones, Jan. 1979).
19. It is interesting to note that a litany, beginning with a plea for the Help of God (See Appendix 4(3)) was sung in Early Christian Rome before setting out on the Great Litany Procession through the city on April 25th (Ní Chatháin 1980, 132-3).
20. For a detailed discussion of pattens in their modern context see Evans 1957, 262-6.
21. 'quatenus intrantes ecclesiam omnes etiam literarum ignari, quaquaversum intenderent, vel semper amabilem Christi sanctorumque eius, quamvis in imagine, contemplarentur aspectum; vel Dominicae incarnationis gratiam vigilantiore mente recolerent; vel extremi discrimen examinis, quasi, coram oculis habentes, districtius se ipsi examinare meminissent. (King 1963, 404-7).

Chapter IV. THE CLONMACNOISE GROUP

The monuments discussed in this chapter form a closely linked group of sculpture centred on the important monastic 'city' of Clonmacnoise (Map II). The group consists of six monuments, Clonmacnoise I - IV¹, Banagher and Bealin. The first four are clearly associated with Clonmacnoise; the other two were found nearby². Surprisingly little work has been done on this group in the past (see bibliography for each monument in gazetteer) the only significant discussion being in Françoise Henry's Irish Art (1965, 143-7, 154-6),³ and its importance has probably been underestimated. In the past Clonmacnoise IV has been included with the Ossory crosses (op cit 139; Roe 1962, 9) but the detailed breakdown of the ornament attempted here will demonstrate that it is essentially a part of the Clonmacnoise group.

According to tradition Clonmacnoise was founded by St. Ciarán, probably in the decade 540-550 (Kenney 1929, 378). The early history of the monastery is obscure and Kathleen Hughes (1958, 253-4) has suggested that it did not really emerge into the limelight until the seventh century. It is not known whether there was a scriptorium there in this period, as there was at Bangor and Kildare, but undoubtedly its power was increasing. Ultimately it became one of the most important monasteries in Ireland, perhaps surpassing even Armagh as a centre of learning and literature (Kenney 1929, 377). Such prestige was attained partly by an alliance with the Southern Uí Néill which gradually brought Connaught within its sphere of influence and evidence for the increasing benefit and power derived from this may be seen in the annals. For example, in 744 the lex Ciarán and the lex Brendain, laws of protection which had to be arranged in agreement with the secular rulers of the territory, were both enacted in Connaught (ibid; Mac Niocaill 1972, 148). By 788 however, it is only the lex Ciarán which is recorded as having any sway in this area (Hughes 1958, 254). At the same time the obits of scribes noted in the annals show the increasing importance of Clonmacnoise as a cultural centre and it has also been suggested that regular annals may have been kept there from the mid eighth century

onwards (Hughes 1972, 138-40). In addition a number of early grave-slabs from Clonmacnoise testify to the activity of sculptors during this period (Lionard 1960-1, 145; Petrie 1872; Macalister 1909) (see Appendix 3). Therefore, by the end of the eighth century Clonmacnoise seems to have been an important monastic centre possessing a suitable environment in which a sculptural workshop producing larger monuments might flourish.

The geographical situation of Clonmacnoise also helped the monastery's rise to power. At first sight its position on the flat bogland of the eastern bank of the Shannon seems somewhat remote but in practice it was a focus of routes using both the river and the ancient land highways along the eskers (Hughes 1972, 21; Hughes and Hamlin 1977, Fig. 2). Thus the monastic 'city' was clearly open to outside influences. There is even a reference to Gallic merchants sailing up the Shannon to bring wine to the monastery (Kenney 1929, 379).

Today the archaeological remains at Clonmacnoise are impressive. No excavation has taken place but substantial parts of the vallum monasterii are still visible (Thomas 1971, Fig. 7). Inside this is a modern enclosure within which is the core of the monastic remains, the Cathedral, seven stone churches, two round towers, a great number of pieces of sculpture and a little way to the east is the Nuns' Church, a fine example of the Irish Romanesque (Harbison 1975, 202-4).

1) The Form and Layout of the Monuments

A variety of monument types are represented amongst the Clonmacnoise group. Bealin and Clonmacnoise IV are crosses, Banagher and Clonmacnoise I are tall shafts while Clonmacnoise II and III are considerably smaller. The original form and use of the shafts is unclear. Clonmacnoise I is obviously no longer complete since it has a tenon projecting from the top onto which another piece of stone, wood or metal may originally have been fitted. Françoise Henry (1965, 144) has suggested that it could have been one vertical side of a rectangular door frame in which case the tenon would be for the attachment of a lintel. This is not impossible, though the frame would have to project sufficiently from the wall of the building to render all three sculptural faces visible. In view of the fact that the crosses on Iona are not monolithic (Stevenson 1956, 86-7, Fig 1⁴) (see pp 31, 35) one should also entertain the possibility that a crosshead, with or without a wheel, could have been joined to the top of the shaft. Since the shaft is only decorated

on three sides it may have stood against a vertical façade of some kind.

The Banagher shaft, however, is decorated on all four sides and is therefore entirely freestanding. There is a small mortice hole in the centre of the top of the shaft but this seems hardly large enough to support a superstructure of any size. In addition the function of the shaft seems to have been altered at some point. A rectangular slot has been cut out of the top panel on both narrow faces. This seems to be secondary as the slot on B 1 appears to be cut straight through the zoomorphic ornament.

Clonmacnoise II and III are only carved on three faces. They may have been freestanding but it is also possible that they may have formed part of more complex structures, perhaps a shrine or a piece of furniture, although there are no mortices or tenons to support this.

Both Bealin and Clonmacnoise IV have Type I crossheads (Fig. 39). The Bealin crosshead appears large and heavy compared with the size of the shaft though, if the cross ever had a base, this may have made the proportions more even. The layout of the ornament on A 1 and C 1 - 3 seems clumsy, especially the use of a triquetra knot in the rectangular space of the upper cross arm of C 2. The crosshead of Clonmacnoise IV is much smaller and the ornament, although arranged in a similar way to Bealin A 1, more accomplished. The use of bosses against a background of abstract ornament on the crosshead is also characteristic of the Ossory crosses (see p 98) and Kilree Face A (see p 134). It is unknown whether Bealin ever had a capstone. The roofshaped capstone on Clonmacnoise IV may be compared with Killamery (see p 134).

The Type I crosshead is found elsewhere in Ireland at Kilree and Killamery, Termonfechin and Castledermot North and South (Roe 1954, Pl XI; Henry 1967, Pls. 66, 71). More interestingly it is much more common in Pictland and Dalriada (Allen and Anderson 1903, II, No. 102A). It is found on some of the early Class II slabs, Aberlemno II, Meigle I, Rossie and Eassie, although here the wheelarcs are thin and cusp-like (op cit, III, Figs. 227A, 310A, 322A, 231A). Aberlemno II has particularly close similarities with Clonmacnoise IV and Bealin, having a slightly elongated upper cross arm crowned by a small triangular pediment (see p 37) and the crosshead ornament also extends part of the way down the shaft. Romilly Allen (op cit, III, 269; Cruden 1964, Pl 44, background reconstruction) has suggested the same crosshead form for the fragmentary freestanding cross St. Vigean IX⁵. In Dalriada, St. Martin's Cross, Iona also has a Type I crosshead. Henry (1965, Pl. 85)

has already alluded to the similarity between this and Clonmacnoise IV though caution should be exercised since slots at the ends of the horizontal cross arms indicate that these were once longer although their original form is unknown. The position of the bosses on the crosshead on some of the Iona monuments (see p 99) is also found on Bealin and Clonmacnoise IV.

The form and layout of the shafts on Banagher, Bealin and Clonmacnoise I, II and III may be closely compared. Clonmacnoise IV is not similar and therefore is discussed separately. The dimensions of the shafts may best be summarised in tabular form (Fig. 7):-

Monument	Width at Bottom	Depth at Bottom	Height
Bealin	33 cm	26 cm	
Clonmacnoise I	40 cm	32 cm	
Banagher	39 cm	17 cm	
Clonmacnoise II	37 cm	18 cm	92.5 cm
Clonmacnoise III	38 cm	18 cm	91.5 cm

Fig. 7.

On Bealin and Clonmacnoise I the dimensions are not identical but the ratio of width to depth is approximately the same, being just over 4:3. Banagher and Clonmacnoise II and III have almost identical dimensions, the width being similar to Clonmacnoise I, while the depth has become greatly reduced to make the ratio 2:1. The height of the two smaller shafts is also similar.

The dimensions of the shafts undoubtedly affect the layout of the ornament. On Bealin and Clonmacnoise I only some of the motives are placed in panels. The shaft panels on Bealin Face A may be compared in size with those on Clonmacnoise I Face A, all being approximately 30cm x 30cm. On Bealin the shaft panels decorated with abstract ornament on Faces B and D are also fairly constant at approximately 21cm x 30cm. On Banagher and Clonmacnoise II and III the depth of the narrow faces, compared with Bealin and Clonmacnoise I, is much less with the result that the panels on these faces are much longer and thinner.

The appearance of Clonmacnoise IV is rather different from other monuments in the Clonmacnoise group, since the emphasis in the layout is not upon individual decorative motives but rather on the monumental

cross form itself. This, together with the high relief rope mouldings, the correspondingly recessed faces of the cross and the large base are all characteristic of the Ossory crosses (see p 96) and it is this superficial appearance rather than the actual decoration which has led to Clonmacnoise IV being grouped with these monuments (Henry 1965, 139; Roe 1962, 9). The rope mouldings on Clonmacnoise IV are decorated with a herring-bone effect which may be compared with Killamery (see p134). However, its ultimate origins are to be traced back to Vernacular Style metalwork and in particular to trichinopoly examples of which may be seen on the Tara Brooch and on the Derrynavlan⁶ paten where the metalwork bindings are actually executed in this technique (Henry 1965, Pl 38; Ryan, M. 1980, 1).

2) Stone

It is interesting to note that amongst the Clonmacnoise monuments both limestone and sandstone are used. Clonmacnoise is situated on a limestone esker and it would therefore seem natural to use this as transportation of stone over long distances is difficult.⁷ Bealin and Clonmacnoise I and II are all carved from limestone which is presumably local to the area. The face of the limestone on these monuments is now badly weathered. However, on Banagher and Clonmacnoise III and IV (also V and VI) and nearly all the surviving grave slabs sandstone is employed. Padraig Lionard (1960-1, 145) has suggested that this may have been sailed up the Shannon from South Clare. There is one small outcrop of sandstone some miles from Clonmacnoise (Geological Survey, Sheet 108) but, if Lionard is correct, the stone was being transported over a considerable distance.⁸ This is interesting as other sculpture in this period, inasmuch as it has been studied, appears to have been using the nearest suitable stone (Personal Communication, Dr. John Jackson, August 1977). The sandstone is of high quality and has weathered well so perhaps a prestigious monastery like Clonmacnoise could afford to transport it a considerable distance.

3) The Ornament

The majority of the decoration on these monuments consists of a great variety of mainly abstract patterns. Figural representation is used much less and is less prominently placed.

a) Interlace

Interlace is used extensively on all the Clonmacnoise monuments, and it is amongst this group that evidence for the principles of construction of interlace patterns has proved easiest to trace (see p 9). Careful measurement of all the interlace patterns has suggested that with one possible exception, Clonmacnoise IV C 6, they are constructed on a square grid. Secondly, the group seems to be bound together by the use of certain unit measures, and proportions of these, for the construction of the patterns. The unit measures may best be summarised in tabular form:-

Monument	Unit measures						
	1.5	3	6	1	2	1.25	2.5 cm
Bealin	X	X	X				
Clonmacnoise I	X	X			X		
Banagher	X	X		X	X		
Clonmacnoise II		X			X		
Clonmacnoise III		X			X		X
Clonmacnoise IV	X	X			X	X	

Fig. 8

As can be seen by far the most common is 3cm. 2cm is also common although it is not found on Bealin. 1.25 and 2.5 cm are little used since they are only found on Clonmacnoise III and IV. The strand width is usually either the same as the unit measure or one half. On the whole the group shows a preference for the use of a rounded strand in fairly low relief. In one instance, Clonmacnoise III D 1, a bumped strand is employed.

This group is also bound together by its repertoire of interlace ornament. Indeed the Clonmacnoise monuments exhibit the greatest variety of interlace patterns used on any group of crosses in Ireland. However, despite this the repertoire is surprisingly small. It may be summarised in tabular form:-

MONUMENTS

PATTERN		BEALIN	CLONMACNOISE I	BANAGHER	CLONMACNOISE II	CLONMACNOISE III	CLONMACNOISE IV
Plaitwork	{ 4 strand plait						✓
	{ 6 strand plait	✓			✓		
A	{ Basic A	✓		✓	✓		✓
	{ Spiralled A		✓				✓
B	{ Basic B					✓	✓
	{ Turned B		✓				✓
	{ Half B	✓					
	{ Simple B						✓
	{ Spiralled B						✓
C	{ Basic C	✓	✓				✓
	{ Turned C			✓	✓	✓	✓
	{ Encircled C						✓
D	{ Turned D			✓		✓	✓
E	{ Basic E	✓		✓			
	{ Turned E				✓		
	{ Encircled & Turned E	✓		✓	✓		
	{ Simple F	✓					
	{ Closed Circuit F					✓	
	Triquetra	✓					✓

Fig. 9

Bealin Interlace patterns are used on this cross in several different ways. Firstly, they are employed to decorate square and rectangular panels both on the shaft, A 2 and 3, B 1 and D 3, and on the crosshead, C 1 and 2 and D 1. Secondly, there is one example of a long thin rectangular panel, D 2. Interlace is also used to decorate the low bosses, the flat roundel and the background of the crosshead, A 1.

The only unit measures used on Bealin are 3cm and proportions of it 1.5cm and 6cm. The width of the unit measure, the size and type of the strand,

and the complexity of the pattern produce different stylistic effects.

Firstly, a single example of a complicated pattern on Bealin A 3 gives a 'lace-like' appearance which Françoise Henry (1965, 144) has picked out as one of the hall-marks of this group of monuments. This effect is achieved by the combination of a complex pattern, Encircled and Turned E, with a small unit measure, 1.5 cm, and a slender strand width of .75 cm.

Otherwise the patterns are less complex. Bealin B 1 and D 3, which are placed in corresponding positions on the narrow faces of the shaft, are decorated with simple patterns, Basic E and Basic A. On D 3 the sculptor seems to have encountered some difficulty in fitting in a third register of pattern, as the height of the panel, 30.5 cm. is insufficient and therefore the terminal strand has become thin and squashed. However, compared with Bealin A 3 these patterns have a much sturdier appearance. This is achieved by the simplicity of the pattern and the use of a larger unit measure, 3cm, and broader strand width, 1.5 cm.

There are other simple patterns conceived on a much larger scale. Three of these, A 2, D 1 and C 1, make use of a strand type consisting of two strands placed side by side forming a median groove between them. This gives the patterns a heavy appearance but the strand type does add interest to a very simple pattern. The unit measure employed is quite large, 3 or 6cm. Thus the heavy appearance of A 2, a simple six strand plait with zoomorphic terminals (see p 62), contrasts well with the much more delicate strands of A 3 placed immediately below. On D 1 the entire panel (H: 27 cm; W:15 cm) is decorated with a single large interlace knot, Half B, the same pattern being continued on D 2 on a much smaller scale. The use of a single pattern element to decorate such a large surface area does not seem to be paralleled elsewhere. The placing of C 1, a large square panel with a single unit of Basic C, at the centre of the crosshead is also very unusual. The pattern appears somewhat nearer on the right-hand side but perhaps this is accentuated by the large size of the interlace loops. Square panels decorated with spiral ornament are found elsewhere in Ireland, for example Kinnitty I C 1 (see p 177). However, there are no Irish parallels for the use of interlace in this way though it is sometimes found on Pictish sculpture, for example Nigg (Allen and Anderson 1903, III, Fig. 72), although here the interlace pattern is much more closely knit.

The Triquetra knot on Bealin C 2 is also conceived on a large scale but the appearance is more delicate because a double strand has been employed giving it a rather lop-sided appearance. The use of a triangular motif on the rectangular field of the top cross arm, which means leaving quite a large area uncarved, is also unusual especially considering the distinct horror vacui which is a characteristic feature of Hiberno-Saxon art. The origin of the motif, which is not often found in sculpture, may be derived from one used to decorate a single quadrant of a roundel. In metalwork there is an example on one of the quadrants of a boss on the Tessem mount (Bakka 1963, Fig. 57) and in the Book of Kells a number of triquetra knots are found interlinked to decorate a roundel (e.g. f 29 R).

The crosshead of Face A is decorated entirely with interlace. The use of Basic C, here adapted as a roundel, on the surviving bosses and central roundel may be compared with C 1 although the delicate appearance of the ornament has much more in common with A 3. The central roundel has been made larger by the addition of a border of Simple F elements. The sculptor has skilfully managed to adapt the pattern to a circular shape. The constructional grid for this probably consists of straight lines radiating from the centre of the roundel crossed by concentric circles drawn from the same point. An identical use of Simple F is found on Kilree C 2 (see p143). The background to the bosses and roundel is formed by an uneven two strand twist. The incompetence of the execution of the pattern suggests that, having placed the bosses in the centres of the cross arms, the sculptor had to devise a way of filling the area round them, an area which did not have a constant width. This is the same problem that is encountered by the sculptors of the Ossory crosses with which Bealin A 1 may be compared (see p.107). In this instance it seems unlikely that any constructional grid was used; probably only the crossing points of the strands were indicated.

Therefore the interlace patterns on Bealin, though they are used in a number of different contexts, display a unity of construction since they all conform to proportions of the 3cm unit measure. With one exception the patterns are uncomplicated. The great variation in the appearance of the patterns is achieved by the differing scale and changes in the strand type. The placing of some of the patterns on the cross-head is unusual and in some cases the sculptor seems to have had difficulty in working out the arrangement of the ornament which could suggest a certain amount of experiment.

Clonmacnoise I The majority of the interlace is found on the most prominent face, A, where it is used to decorate all five panels. There are two further interlace panels on the narrow faces B 3 and D 4.

The interlace panels on Face A are badly weathered but they may be reconstructed with a fair degree of certainty (Fig. 10). The reconstruction shows a series of complex patterns of a delicate appearance which may be immediately compared with Bealin A 3. Indeed the pattern on Clonmacnoise I A 5 is almost identical to Bealin A 3 including the unit measure. The only difference is that the height of Clonmacnoise I A 5 is 2cm greater than Bealin A 3, the loops at the top of the pattern having been arched considerably to fill the increase in space. The roundels decorated with Basic C on Clonmacnoise I A 1 may also be directly compared with Bealin A 1, the same unit measure being used.

Overall Clonmacnoise I Face A uses two unit measures, 1.5 and 2 cm, and these combined with the rounded strand and low relief produce a delicate lace-like effect. Element C is also used extensively. Several features may be noted. Firstly, on A 1 each roundel has been placed within a square panel. The sculptor seems to have tried to alleviate the emptiness round the roundels by introducing curious strands which cut across the corners of the moulding. This is also found on A 2 but otherwise seems unparalleled in sculpture. The clue to the origin of this stylistic detail may lie in manuscript illumination. The extension of the frame of a panel into the space around a motif so as to give the impression that it is not floating in mid air is found in the Echternach Gospels (MS: BN 9389) where the frame projects into the area around the Evangelist symbols of St. Matthew, St. Mark and St. John (Nordenfalk 1977, Pls. 9, 10, 11). There is a further example in the Lichfield Gospels where semi-circular projections similar to those on Clonmacnoise I are found on the St. Mark Portrait page (op cit, Pl. 24).

Secondly, as has already been noted (see p 8), on many interlace patterns the strands naturally break and rejoin to form cruciform voids. The pattern on A 2, Spiralled and Surrounded C, is a particularly good example of this since the sculptor seems to have attempted to emphasise the cruciform shape. The panel has a rather disorganised appearance. The four C elements have been carefully constructed but the sculptor appears to have had problems in tying up the loose ends. This has led him to introduce not only extra strands linking up the corners but also semi-circular projections in the centre of the perimeter on each side.

Fig 10

CLONMACNOISE I

Face A

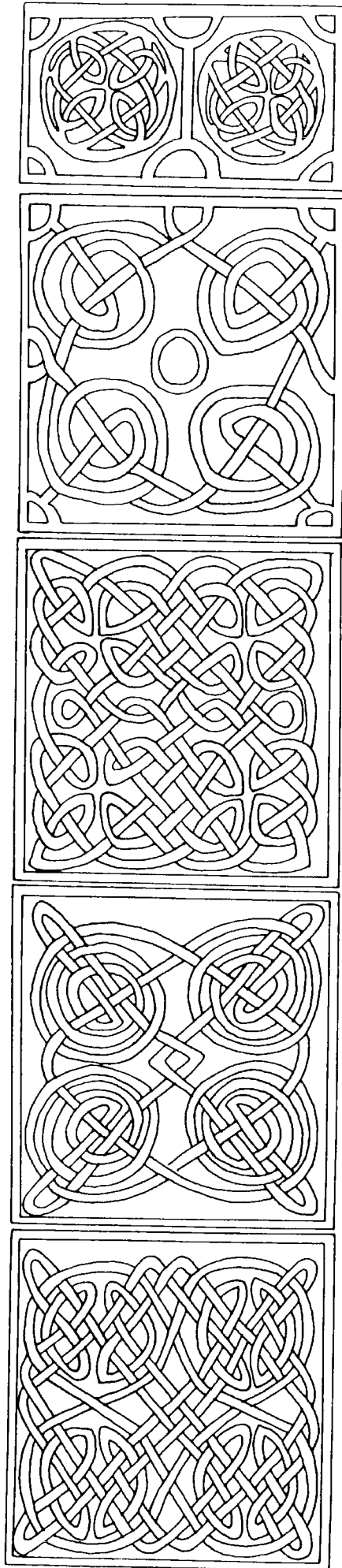

At the bottom of one panel one strand terminates simply by being abutted against another. A second feature, which is unique, is the circle in the centre of the panel, which is not attached to the rest of the pattern in any way. It has been substituted for the diagonal strands crossing in the centre of the pattern. Both these features draw attention to the cruciform shape in the centre of the panel at the expense of the actual pattern. In the early group of Pictish Class II monuments St. Vigeans VII (Cruden 1964, Pls. 48, 49) shows a similar use of a Spiralled and Surrounded pattern, in this case F, in two registers of two units where the diagonals have been retained still bearing a large cruciform shape in the centre.

Thirdly, on Clonmacnoise I A 3 a simple Basic C pattern has been increased in complexity by placing it four elements abreast. Because the panel is slightly longer than it is wide (33 x 30cm) a two strand twist has been introduced as a filler. This may be compared with Ahenny I A 3 and Tihilly D 1 (see pl73).

In contrast the patterns on B 3 and D 4 are on a much larger scale. B 3 in particular may be compared with Bealin D 1 and C 1 since a 3cm unit measure and a thick strand with a median line are used. The dimensions of the panel too are almost identical to Bealin B 1 and D 3. The relief of the panel is unusually high, rising to 1 cm in places. Both panels are examples of changing patterns which are fairly common amongst the Clonmacnoise monuments but are not found on Bealin.

Therefore on the whole the interlace on Clonmacnoise I may be closely compared with Bealin. The same unit measure of 3cm and proportions of it is employed but a 2cm unit measure is also used. The emphasis seems to be on the delicate 'lace-like' effect found on A 1, which is one of the most complex series of interlace found on Irish sculpture, the larger scale designs being confined to the narrow faces.

Banagher Interlace ornament is used extensively on this shaft, being found in square and rectangular panels on B 3; C 1 and 3 and D 1 and D 3. Zoomorphic terminals are a characteristic feature of the interlace ornament on this shaft.

Banagher C 1 and C 3 are large scale patterns similar to those already noted on Bealin and Clonmacnoise I, a 3cm unit measure and a strand with a median line being employed. On C 1 the Basic A pattern is three elements abreast and three registers high which gives a rather

clumsy appearance which is increased by the lack of gaps between the strands. C 3, a single unit of Turned D on a large scale uses a different strand variation, a double strand with a median line. There is a similar pattern on Kells South (Roe 1966, 15).

The patterns on the narrow faces of the shaft are rather different. As has already been noted (see p 48) the depth of the Banagher shaft is much less than Bealin or Clonmacnoise I. In consequence the shaft has been broken up into much longer thinner panels. The repertoire of ornament available is similar to that of Bealin and Clonmacnoise I but the patterns have had to be adapted to more slender dimensions. The sculptor has tackled this problem in two different ways. Firstly, on B 3 and D 1, the patterns are executed on a very small scale using a small unit measure, 1 cm. The effect is to give the panels a cramped, over-filled appearance. The patterns themselves are accurately executed but there are hardly any gaps between the strands which makes the actual line of the design very difficult to follow.

Secondly, on Banagher D 3 a larger unit measure of 1.5 cm is used but the number of strands making up the design has been decreased, thereby reducing the width of the pattern as a whole. The effect is similar to the lace-like patterns on Bealin and Clonmacnoise I and the upper half of the pattern, Encircled and Turned E, is identical to Bealin A 3 and Clonmacnoise I A 5 except that the pattern is only one unit wide.

Therefore the interlace is similar to Bealin and Clonmacnoise I except for the small scale patterns on the narrow faces. Most of the patterns are not very complex, variety being added by changes in the strand type and the frequent use of zoomorphic terminals.

Clonmacnoise II and III On these two shafts, which have almost identical dimensions, the depth being similar to that of Banagher (see p 48), interlace is restricted to the narrow faces. These, apart from the insertion of a step pattern on Clonmacnoise II B 1, are decorated exclusively with interlace. The narrow faces of Clonmacnoise III have been badly damaged but may be reconstructed with a fair degree of certainty (see Fig. 11).

Like Banagher the depth of the shaft is bound to affect the form of the interlace ornament. The solution adopted here is the use of simple patterns composed of six strands. The use of only six strands is bound to limit the complexity of the pattern and if repeated over a long panel

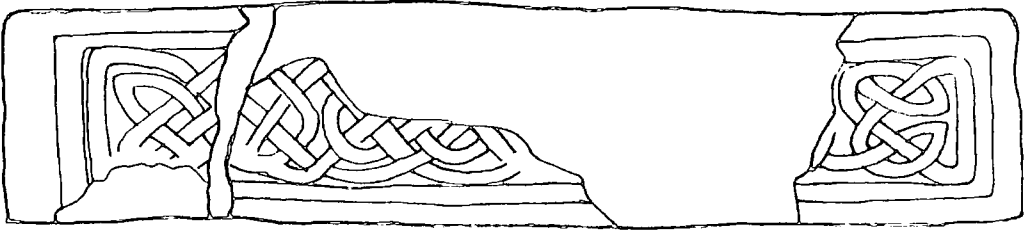

B

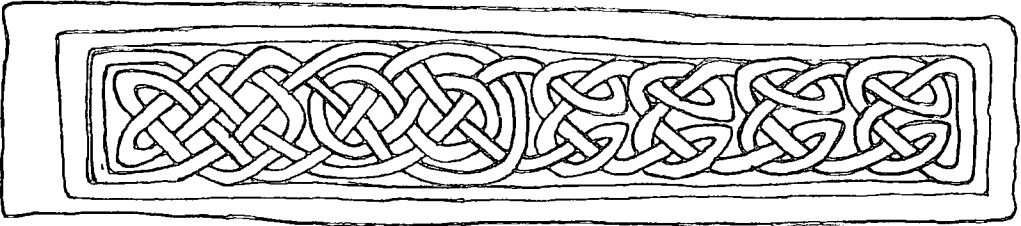

Reconstruction

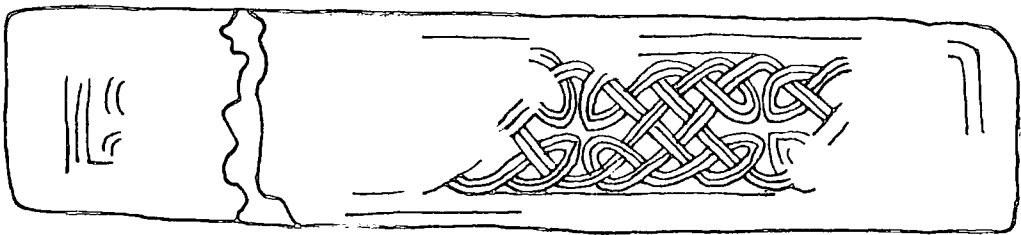

D

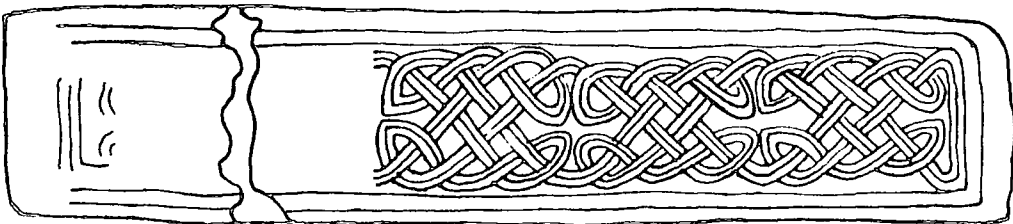

Reconstruction

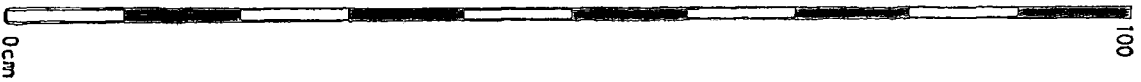

0cm

Fig 11 CLONMACNOISE III

it may become monotonous. This has been avoided by the use of changing patterns and the rapid interchange of a variety of interlace elements without a break in the pattern. Three unit measures are used, 2cm, 3cm and on Clonmacnoise III D 1 a rare example amongst the Clonmacnoise monuments of 2.5cm. A variety of strand types are also used, Clonmacnoise III D 1 being again unusual in that it has the only example of a humped strand. The strand width on the whole gives the patterns a robust appearance, the exception being Clonmacnoise II B 1 where the strand is thinner and in consequence the pattern appears rather weak. Of the patterns used Turned C is common, being found on Clonmacnoise II B 1, Clonmacnoise III B 1 and also Banagher D 3. The second pattern on Clonmacnoise III B 1 may be reconstructed to show a closed circuit F pattern (Fig. 11). Element F is rarely used on Irish sculpture and when it is, it usually appears as a simple carrick bend and therefore this pattern is unusual. This panel has three pattern changes in only 38 cm of length which gives it a rather disordered appearance.

Clonmacnoise IV As has already been noted (see p 48) the appearance of this cross is rather different from the rest of the monuments in the group. However, interlace ornament is employed extensively and the similarity of this, both in the designs and in the unit measures, is the major reason for classifying Clonmacnoise IV with the rest of the group. Due to weathering it has not been possible to recover all the patterns. However, like Bealin, interlace is used to fulfil a number of different functions. Firstly, it is used to decorate several long, thin rectangular panels on the shaft, B 7 and D 7, the wheelarcs, B 2, B 6, D 3 and D 5 and the base, C 6 and D 10. Secondly, there are square and rectangular panels on the broad faces of the shaft, A 3 and A 4, the ends of the horizontal cross arms, B 4 and D 4, the butt, B 9 and D 9, and the base, A 8 and A 10. Thirdly, interlace is used to ornament bosses both on the crosshead, A 1 and C 1, and on the spiral panels, B 8 and C 2.

On this cross there is a wide variety of interlace ornament, the patterns ranging from the very simple to the complex. Several different styles of carving are also employed. In the first the strand is highly modelled. This high relief may have been favoured because of the large size of the perimeter mouldings which makes the panels look recessed. The greater depth of carving helps to make the patterns stand out. Many

of the long, thin rectangular panels are carried out in this fashion. A good example is B 7 which has a complex changing pattern similar to those on Clonmacnoise II and III. Four different pattern units are used, the third being particularly interesting since an eight strand pattern unit has been introduced into what is otherwise a six strand pattern. This is achieved by the unusual introduction of a bar terminal at the bottom of the unit in order to link the two loose strands. Other examples are found on the wheel arcs B 6 and D 5. On both of these it may be seen that the sculptor has had difficulty in fitting the patterns into panels, the length of which is predetermined by the length of the wheel arcs. For example B 6 has a series of somewhat untidy loops at the bottom as there is insufficient room for a complete register of pattern. Again, like Clonmacnoise II and III, the patterns are simple and composed of only six strands.

A further difficulty in the adaptation of a pattern to the cross form may be seen on the rectangular panel B 4 (Fig. 12). Here a single unit of pattern B with outside strands was not sufficiently wide to fill the entire panel. Therefore the sculptor joined all the loose strands except two, one at the top and one at the bottom, which he used to graft on a further half unit. This looks clumsy because of the almost complete break between the two sides of the pattern. Furthermore the U bends forming the B elements have been lost in the centre and at the top right hand corner of the panel. With some thought the pattern could easily have been stretched to cover the entire panel by the introduction of an area of plaitwork in the centre (Fig 12). This would seem to suggest that although the sculptor was skilful at copying patterns he was not very capable of inventing them.

Secondly, there are two long thin rectangular panels, D 7 and D 10, in slightly lower relief. D 7 may be compared with Banagher D 3 as both show versions of Encircled patterns adapted to a single row of units. The slight asymmetry of Clonmacnoise IV D 7 is interesting (Fig. 12). This can be seen where the top register is joined to the second and the third to the fourth. In each case on one side the strands are crossed and at the other they are not. It is unnecessary to introduce this extra crossing point in order to maintain the pattern and unusual when one considers the normal attention to symmetry in interlace. The pattern, Encircled C, is also slightly unusual because the upper pair of the C element loops in each register is an extension of the encircling

**CLONMACNOISE IV
B 4**

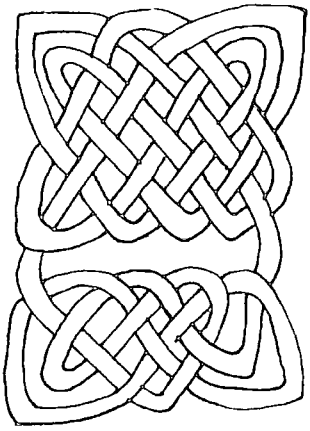

ACTUAL PATTERN

**SIMPLE PATTERN,
B WITH OUTSIDE STRANDS**

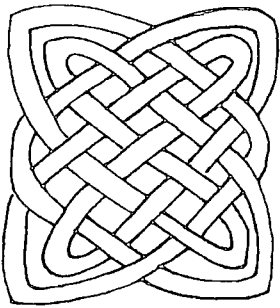

CORRECTED PATTERN

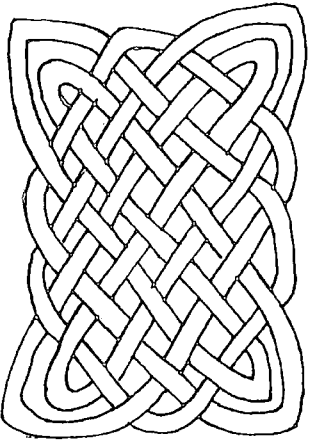

**CLONMACNOISE IV
D 7**

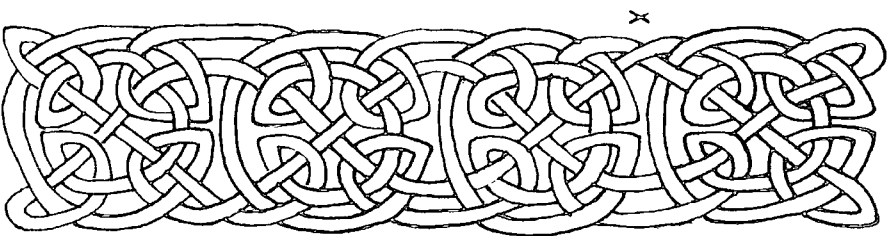

X = ASYMMETRICAL CROSSING POINTS

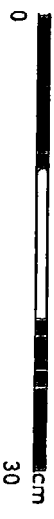

Fig 12

strand rather than being contained within it. The extensions from the lower loops in each case form extra diagonals across the upper loops and then join. This feature is found elsewhere in Ireland on Tihilly A 2 (see p 173) and Monasterboice South (Macalister 1946, Fig. 9.24). It is also used in Pictland at Gask, Meigle IV and Iona II (RA Nos. 701, 701A). D 3, Spiralled and Surrounded A, also only one unit abreast, may be compared with Clonmacnoise I.

Thirdly, the two interlace panels on the Broad faces of the shaft, A 3 and 4, are in very low relief and, because of the prominent perimeter mouldings, seem inconspicuous. A 3 especially is on a very small scale with a minute strand width and must have a correspondingly small unit measure. The precise pattern is impossible to reconstruct but it may be possible to compare it with an Enclosed C pattern on a similarly small scale on Kells South (Roe 1966, Pl. II). A 4 is on a larger scale. The delicate style of carving and the Spiralled pattern may be compared with Clonmacnoise I A 2 and A 4. It is possible that Clonmacnoise IV A 8 and A 10 also fit into this category. They are badly weathered and the patterns cannot be precisely reconstructed. However, although they are large base panels, the patterns are of a similar complexity and may also be comparable with Clonmacnoise I Face A.

Fourthly, there is a simple plaitwork panel on Clonmacnoise IV C 6 which is typical of the interlace on the Ossory crosses (see p104), but is not otherwise found amongst the Clonmacnoise group. The diagonal measurements between the crossing points were consistently more even than those on the horizontal or vertical so the pattern may be constructed on a diagonal grid.

Finally, two different types of interlace are used to decorate the bosses on this monument. The interlace on the bosses on the crosshead, A 1 and C 1, where reconstructable, may be compared with those in a similar position on Bealin A 1. Basic C adapted as a roundel is also found on the bosses on Ahenny I A 1 and the cross at Kilmartin, Argyle (Allen and Anderson 1903, III, Fig. 411). The triquetra knot motif on the central boss of Clonmacnoise IV C 1 may be compared with Bealin C 2. The meshed bosses on Clonmacnoise IV B 8 and C 2 are discussed in connection with the spiral ornament of which they are a part.

Therefore, apart from C 6, the interlace is in the same tradition as that in use elsewhere in the Clonmacnoise group. The variety of styles of carving and the great variation in the quality of the patterns

may indicate that more than one sculptor may have been employed to carve what is, after all, a large scale monument.

Conclusions Therefore, although the interlace repertoire amongst these monuments is not great, there is, nevertheless, considerable variation. Much of this is obtained by the style in which the pattern is carved and three distinctive styles may be recognised amongst this group. Firstly Bealin, Banagher and Clonmacnoise I all make use of large scale patterns where a single pattern element or unit is enlarged to decorate an entire panel. The thick strands are broken up by the use of a median line or groove or by doubling the strand. Secondly, there is a distinctive delicate lace-like style using complex patterns which may be typified by Clonmacnoise Face A but is also found on Bealin, Banagher and something similar on Clonmacnoise IV. Thirdly, six or eight strand patterns are used to decorate long, narrow panels, the monotony being broken by the use of changing patterns. These may be typified by Clonmacnoise II and III but examples are also found on Banagher and Clonmacnoise IV. Apart from these there are several other patterns and styles of carving but these are less characteristic of the group as a whole.

The closest comparisons for this repertoire of interlace ornament is found on Tihilly and Kinnitty (see p173). Connections between the interlace on the Clonmacnoise monuments and Kells South are less easily demonstrable, as interlace at Kells is not a major part of the ornament, but it seems to show a preference for the same sorts of patterns, for example Turned D and Encircled C (Roe 1966, Pl. 7, II). It may also be possible to make some comparisons with the Pictish Early Class II slabs although the majority of the patterns on these are more complex. In particular the large scale patterns using a strand with a median line on Glamis II (Allen and Anderson, 1903, III, Fig. 234A) may be compared with similar large scale designs on Bealin, Banagher and Clonmacnoise I.

The delicate style of many of the Clonmacnoise group patterns, especially Clonmacnoise I Face A, is undoubtedly reminiscent of the manuscript medium. Close comparisons are difficult but some general parallels may be drawn with the Book of Kells. Françoise Henry (1974, 205) describes the interlace ornament of the Book of Kells as 'the stock in trade of insular illumination and lacking in any great virtuosity'. For the most part this is also true of the Clonmacnoise monuments. A

number of the simpler Clonmacnoise patterns are also found in the Book of Kells. For example the trick of adapting Basic C to the roundel form is closely paralleled in the Canon Tables (eg f2V). In one case (f5R) the Basic C pattern is surrounded by an outer band of interlace almost identical to the roundel on Bealin A 1. Basic A, Half B, Basic C and Turned D are also characteristic Book of Kells patterns (eg f8R, f3R, f34R top left, f129 V, f2V). The illuminators also show a tendency to fill long thin panels with simple changing patterns which may be compared with Clonmacnoise III and IV (eg f12V, f15V). Changing patterns are not confined to the Book of Kells. They are found as early as the Book of Durrow (Nordenfalk 1977, Pl. 5) and therefore are possibly a manuscript convention. Turned D and Turned E are also frequently found in the Gospels of MacRegol (MS Bodl. Auc. D.ii.19) for example on the carpet page at the beginning of St. Mark (Hemphill 1911, Pl. II) and there is a further example using a rather robust strand uncharacteristic of manuscript illumination at the beginning of St. Matthew (op cit, Pl. I).

On the whole the Clonmacnoise interlace is not reminiscent of metal working techniques. However, one or two comparisons can be made with the 'engraved' group of Vernacular Style metalwork (see Appendix 2). One of the rectangular plates on the Domnach Airgid (Raftery, J. 1941, Pl. 117), a multi-period shrine of Irish provenance, shows a length of Spiralled A, using a rather thick strand but in a delicate engraved technique, the strands standing out against the hatched background. This may be compared with the Copenhagen Shrine which is also decorated with a delicate double stranded Basic A pattern and a rather careless two strand twist (Bakka 1965, 29-31; Petersen 1940, 79). The choice of the patterns and the fineness of line are both reminiscent of the delicate interlace on Bealin and Clonmacnoise I. In particular the two strand twist used as a filler round the discs on the Copenhagen Shrine may be compared with Bealin A 1 (Mahr 1932, Pl. 16).

b) Zoomorphic Ornament

Zoomorphic ornament is used fairly extensively being found on Banagher, Bealin and Clonmacnoise I and IV but not Clonmacnoise II and III. The ornament on Banagher, Bealin and Clonmacnoise I is very similar employing many of the same motives, but that on Clonmacnoise IV stands slightly apart.

Confronted Dragonesque Beasts with Interlocking Beaks A great variety of dragonesque beast motives are to be found in the repertoire of Hiberno-Saxon ornament (see pp 114, 138) but that on Bealin A 2 where the two dragonesque beasts form terminals to a six strand plaitwork pattern is unusual (Fig. 13). A similar use of confronted dragonesque beasts may be found on Ahenny II A 2. Here the beasts are not formed from the extended strands of an interlace panel but rather their upper jaws have become stretched to form two of the strands of a four strand plaitwork pattern (see p 114). The features of these beasts are not comparable with Bealin but the function they are fulfilling is identical; they are used as a method of decorating an area of awkward shape.

There is one close parallel for the Bealin motif, on a small dome shaped gilt bronze mount (Diam. 5.8cm) now in the National Museum in Copenhagen which David Wilson (1955) has suggested could be Irish and late eighth century. Amongst other motives this mount exhibits three pairs of confronted beasts with long interlocking beaks almost identical to those on Bealin (Fig. 13). On the mount the necks of the beasts spring from relief bosses. They expand towards the head and are decorated in a herring-bone pattern with a central mid-rib. These beasts do not have paws as on Bealin because the top of their bodies is hidden by the arms of a human figure which reaches across to clutch the body of a third serpentine beast below. These beasts have no eyes but there is a suggestion of a curved ear (op cit, 165), though this does not project as on Bealin. At the time David Wilson was unable to provide any parallels for this motif but Bealin provides one such parallel.

There is a second piece of Irish metalwork which should be compared with both Bealin and the Copenhagen Mount. This is the ridge piece of a house-shrine now in the National Museum, Dublin (Mahr 1932, Pl. 18.1). Forming the finial at either end of the ridge is a beast cast in the high

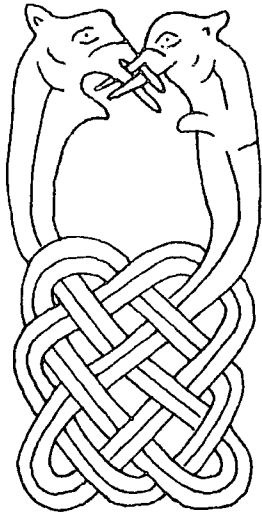

1

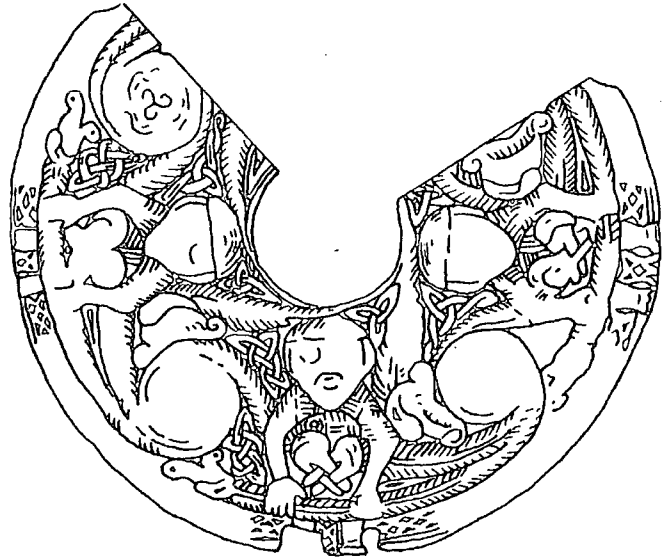

2



3

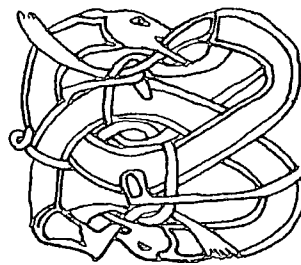

4

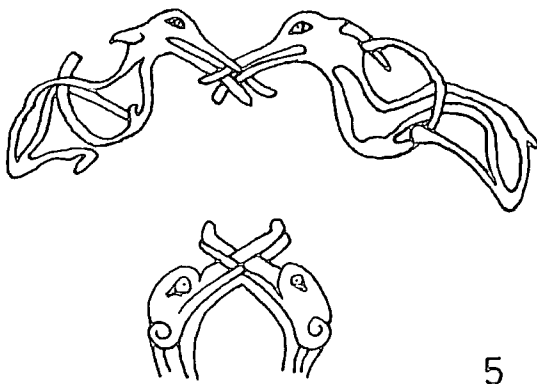

5

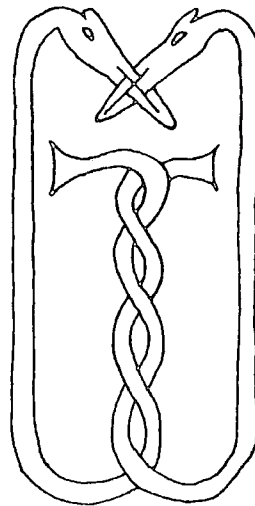

6

Fig 13

1 BEALIN

2 COPENHAGEN MOUNT

3 BENTY GRANGE MOUNT

4 BOOK OF DURROW

5 DURHAM A.II.17

6 MONKWEARMOUTH

relief characteristic of the 'Plastic' style of Vernacular Style metalwork (see Appendix 2). It has small paws and a long open beak. The two beasts confront each other on either side of a human mask set at the centre of the ridge piece.

The origins of this motif are interesting. They can be traced back to the development of Salin's Style II animal on metalwork in Anglo-Saxon England during the sixth and the first half of the seventh century as exemplified by the biting creatures on the Benty Grange hanging bowl escutcheon (Fig. 13), the biting quadrupeds on the Crundalé sword pommel (Henry 1965, Fig 21d) and the dragonsque mount from the Sutton Hoo shield (Bruce-Mitford 1972, Pl 5a) which has two small fins protruding from the top of the body in a similar manner to the paw on the Bealin beast. These metalwork motives are transferred into the manuscript medium and are found in two early Northumbrian Gospel Books. Françoise Henry (1965, Fig. 20) has compared the serpentine initial in Durham A.II.10 with the Benty Grange escutcheon and a more developed version of both the serpent and the quadruped may be seen in the late seventh or early eighth century Durham A.II.17 where there are several examples of pairs of confronted beasts with long interlocking beaks (Fig. 13) (op cit, Fig. 21h, Pl 62; Nordenfalk 1977, Pl.13; Åberg 1943, Fig. 84.9 and 10). Similar creatures are also apparent in the more Celtic milieu of the Book of Durrow dated to the second half of the seventh century. Here the zoomorphic ornament is not mixed with other motives, being confined to the carpet page opposite the beginning of St. John's gospel (Henry 1965, 170-1 and note 1; Kendrick 1938, 100-1). Although the Book of Durrow is early the serpentine beast on this page provides a surprisingly good parallel for the Bealin beast (Fig. 13). Its beak bites its own back leg rather than interlocking with that of another beast but the form of the head, which is clearly separated from the body, with its pointed ear and almond shaped eye is very similar. In architectural sculpture a further surprisingly close parallel is provided by the confronted beasts with interlocking necks on the door jambs at Monkwearmouth which may be dated to the eighth century (Fig. 13) (Taylor and Taylor 1965, 437-8). These have small pointed crests or ears. Their bodies coil into a two strand twist terminating in fish tails.

Turning to Pictland, Isobel Henderson (Pers. Comm) has commented on the similarity of the quadruped in Durham A.II.17 to the Pictish 'elephant' symbol and she has also compared (1967, 120, Fig. 21) the

dragonesque head from the Sutton Hoo shield to a curious Pictish beast with a long snout, pointed ear and flippers (Bruce-Mitford 1972, Pl 5a). Both symbols have features in common with the Bealin beast. However, the hippocamp symbol, found only on Class II monuments (Allen and Anderson 1903, II, 105) provides a closer analogy. A good example of this may be found on Monifieth III (op cit, III, Fig. 243 B) where the hippocamp has a body with a median line, a long, pointed snout and projecting flippers. There are two confronted hippocamps on the Brodie slab (op cit, III, Fig. 136A). A further parallel is provided by a different beast on the early class II slab, Glamis II (op cit III, Fig. 234A). On the horizontal cross arms there are two slender beaked beasts with almond shaped eyes and the suggestion of an ear which emerge from interlace patterns to confront each other either side of the large central roundel.

Serpents with Interlaced Bodies. On Bealin D 5 is an unusual interlocking figure of eight interlace pattern which is designed so as to use only one interlace strand. The upper end terminates in a snake's head, the lower in a slashed fish tail (Fig. 14). This pattern does not fit into Gwenda Adcock's elemental scheme, though an adapted form using two strands so the figure of eight twist becomes even rather than lopsided as on Kilree B 5 is catalogued by Romilly Allen (No. 573).

On Banagher B 1 is a much less elegant version squashed into a panel only 12 cm in width. The upper part of the panel is missing but a serpent's head terminal seems probable since a thin forked fish tail terminal is clearly visible at the bottom.

On Clonmacnoise I D 4 an interlace pattern with zoomorphic terminals also includes a register of this figure of eight twist.

Serpents and other related dragonesque motives are extremely popular in Hiberno-Saxon art (see pp 114, 140). In Pictland they are an essential element of 'Boss' Style which may be exemplified by Nigg and the St. Andrew's Sarcophagus (Stevenson 1955, 117-23; 1956, 84-5) and they are also found on the Iona crosses (Allen and Anderson 1903, III, Figs. 397, 399, 400). The serpent and boss motif is also popular on Irish sculpture, being found on the fragmentary crosshead from Dromiskin (Roe 1954, 113-4, Pls XII and XIII) and many of the 'Scripture' crosses (see p243). In metalwork similar motives are found on such pieces as the Romfohjellen Mount (Mahr 1932, Pl 32.1). In its two dimension^{al} form in manuscripts the serpent is a more unusual motif but interlaced serpents with fish

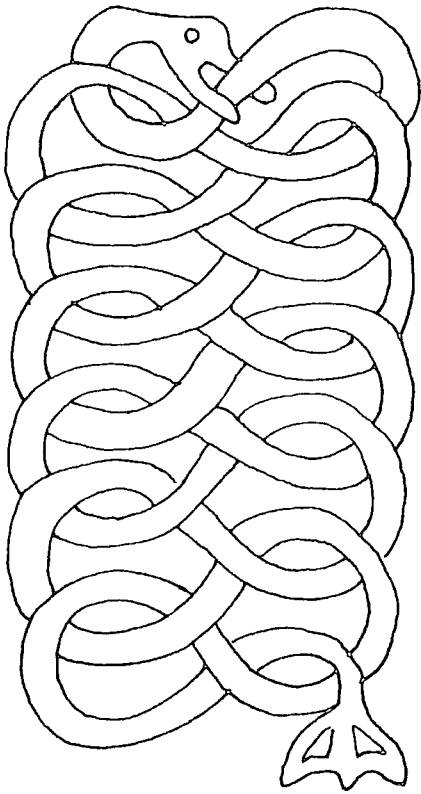

1

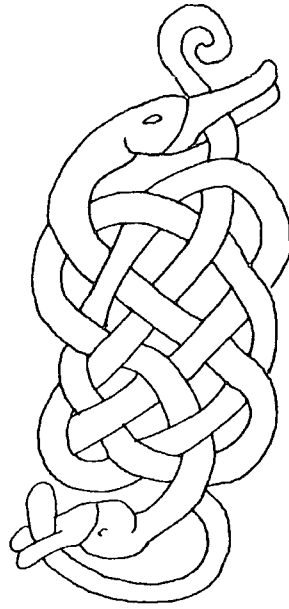

2

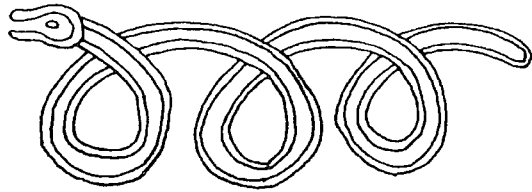

3

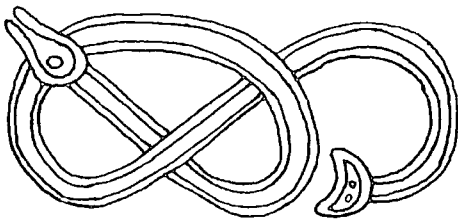

4

Fig 14 SERPENTS WITH INTERLACED BODIES

1 BEALIN D 5

3 HUNTERSTON BROOCH

2 MEIGLE IV

4 HUNTERSTON BROOCH

tails, not unlike Bealin but with their heads seen from above instead of in profile, are an important element in the ornamental repertoire of the Book of Kells (e.g. f130R; Henry 1974, 208, 212).

However, as well as this turbulent 'plastic' style, serpents can also be depicted with a much more delicate filigree approach on objects such as the Hunterston Brooch (Stevenson 1974, Fig. 2, Nos. 8, 10, 12, 14). Here (Fig. 14) the serpents, with or without fish-tails, are shown singly or in pairs in simple interlace coils. In Pictish sculpture there is also a more delicate serpent and this perhaps provides the best parallel for the Clonmacnoise examples. These serpents, or similar beasts with fish-tails, appear on a number of Pictish stones which show a preference for monsters, for example Meigle IV, (Fig 14), a slab with debased Pictish symbols (Allen and Anderson 1903, III, Fig. 331 B)⁹. An example of a similar serpent in Irish sculpture is found on Duleek North (Crawford, H.S. 1926b, Fig. 1).

Birds and Animals with Spiralled Bodies On Bealin C 4 (Fig. 15) is a fine example of Zoomorphic interlace, a procession of three birds with spiralled bodies. The motif runs the entire length of the shaft, in itself an unusual feature which is only paralleled on Killamery C 2 (see p 142). The panel is so well designed that, although each register is slightly different, a perfect balance is maintained. The technique of carving is surprisingly simple. The background is cut away to a consistent level, leaving the pattern in low flat relief. Details, such as the birds' eyes are then picked out with the aid of incised lines. The effect is at once delicate but firm.

On Banagher B 4 there is an almost identical motif but it is so confused as to be barely recognisable. In order to squash it into the long, thin panel the spiral has been reduced to a single coil with the diagonal elements forming a melée in the centre. The effect is clumsy and disjointed.

Thirdly, on Clonmacnoise I D 2 is a very much simpler but nevertheless related version where all the diagonals and appendages have been abolished leaving a single vertical 'S' scroll terminating in the centre with a bird's head. This may be compared with the bird's head spiral terminal on Kilree A 1 (see p138). It is interesting to note that the width of the spiral strand is 1.5 cm and the distance between the centres of the strands 3cm, unit measurements which are common in the Clonmacnoise



1

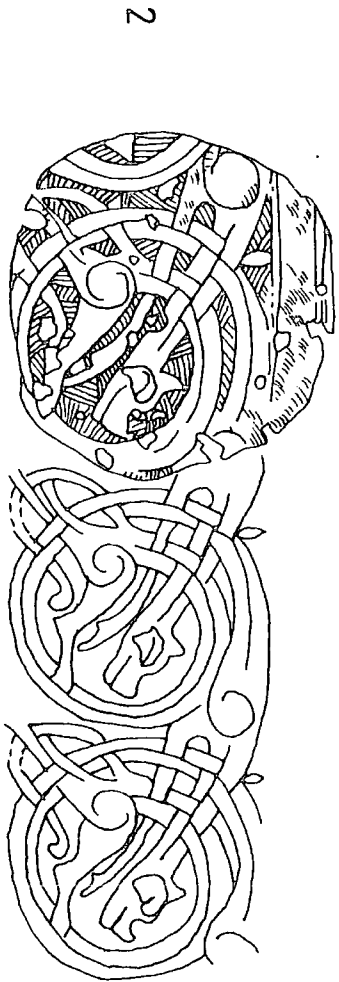

2

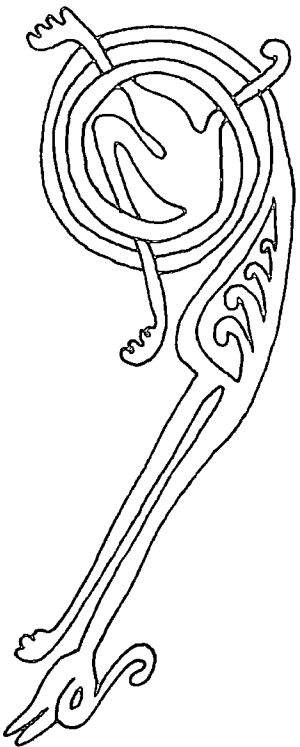

3

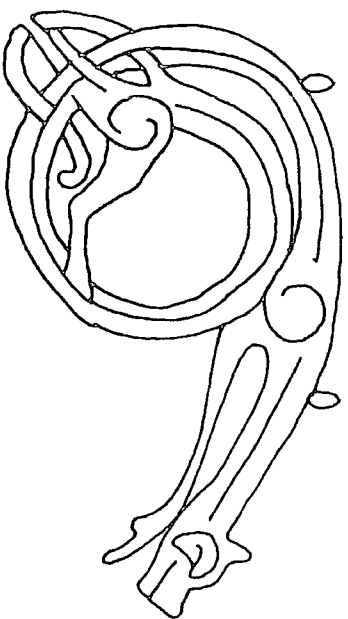

4

**Fig 15.1 BIRDS AND
ANIMALS WITH
SPIRALLED BODIES**
1 BEALIN C 4
2 TORSHOV FRAGMENT
3,4 DETAILS

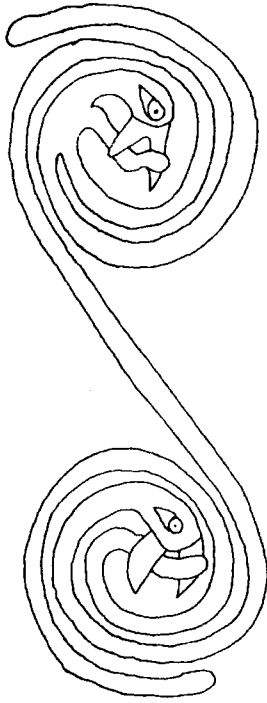

1

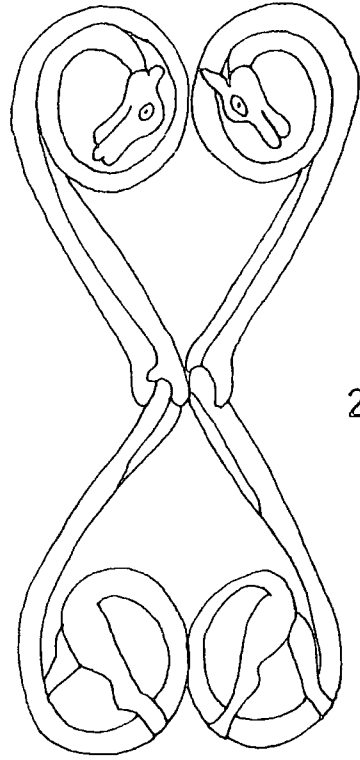

2

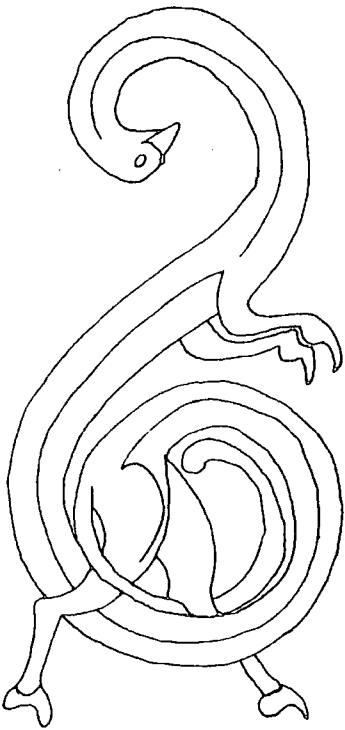

3

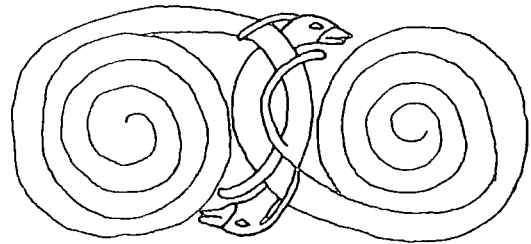
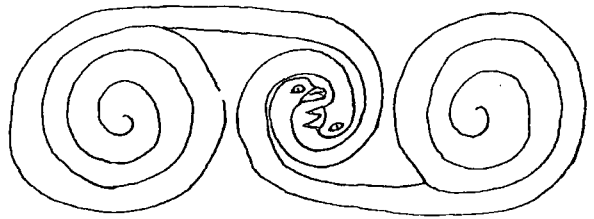

4

Fig 15.2 BIRDS AND ANIMALS WITH SPIRALLED BODIES

1 CLONMACNOISE I D 3

2 LINDISFARNE GOSPELS

3 ABERLEMNO II

4 BOOK OF MAC REGOL

Group interlace patterns (see p 50).

Fourthly, on Clonmacnoise I B 3 is a pair of confronted beasts with spiralled bodies.

Finally, on Clonmacnoise IV D 8, there is a further variation of the procession theme. The panel is badly weathered but it may be reconstructed (Fig. 16) to show a procession of quadrupeds with spiralled bodies. However, there is one important difference between this and Bealin C 4 and this could be an indication of a more developed motif. On Clonmacnoise D 8, instead of the entire quadruped's body being spiralled, each beast is formed of a number of disjointed body elements which are fitted together so as to give the impression of a quadruped with a spiralled body. There are similar quadruped processions on the wheel arc, C 1, but here a reconstruction is not possible.

The origins of these motives may be seen better if the panels are turned on their sides. At this point Bealin closely resembles some of the bird and quadruped freizes found on the 'engraved' group of Vernacular Style metalwork, chiefly associated with the Viking graves in Norway (Bakka 1963, 28-33) (See Appendix 2). The closest parallel for the Bealin bird is provided by a fragmentary piece of bronze sheet from Torshov (Fig 15) (Petersen 1940, 15, Fig 2). Here, although a quadruped is shown, the layout is almost identical to the Bealin bird. In each case the creature stretches across two spiral units. Their heads and one leg form the diagonal elements across the spiral unit in front. On Bealin the head and leg project beyond the spiral while on the Torshov fragment they are contained within it. In both cases the body of the creature expands between the two spiral units forming a wing on Bealin and a spiralled leg joint on Torshov before curving round to form the second spiral unit. On Torshov the spiral and the neck of the quadruped are further complicated by being double stranded. On both the spirals terminate in an expanded hip with two projecting limbs, the Torshov mount having a spiralled hip joint. This mount also provides the closest parallel for the quadrupeds on Clonmacnoise IV D 8. Another comparison may be made with the pairs of adorsed bipeds with spiralled bodies and feline faces on the Vinjum object (Mahr 1932, Pl 30; Bakka 1963, 33) where the shoulder of one animal is part of the hip of the other. However, there do not seem to be any exact parallels for the use of separate body elements to make up the beast.

Birds and animals with spiralled bodies are also frequently found in Hiberno-Saxon manuscripts. An early example may be seen on f26V of the Lindisfarne Gospels where 'S' scrolls with zoomorphic terminals have been combined with interlaced birds whose necks form the diagonals to the

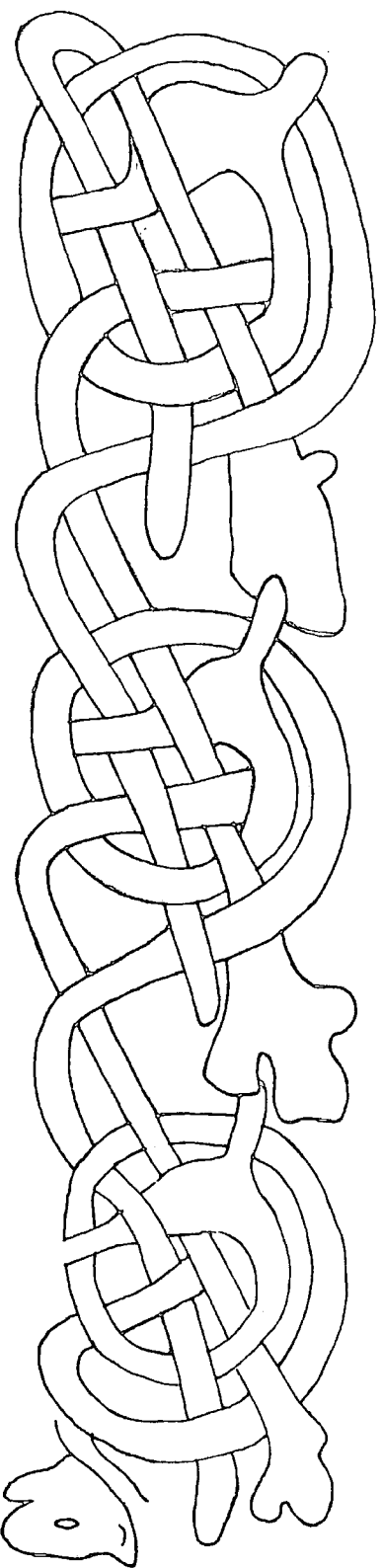

CLONMACNOISE IV D 8

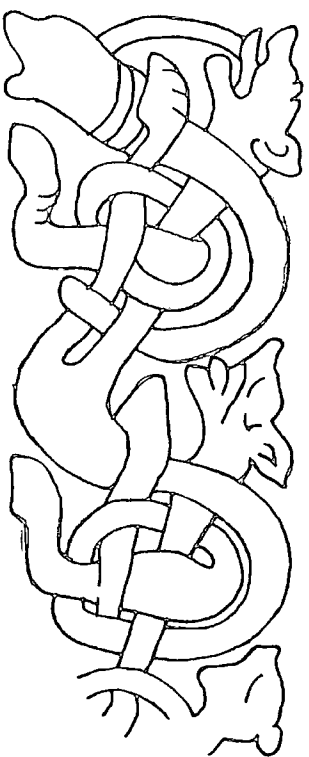

THILLY D 2



Fig 16

spirals. The 'S' scrolls with bird's head terminals on this page provide a good if early parallel for Clonmacnoise I D 2. Processions of birds and animals with spiralled bodies are also frequently found in the Book of Kells. A typical bird procession may be seen on f23V where each bird, instead of stretching over two spiral units as on Bealin C 4, forms a single unit, its head and front leg forming the diagonals to the body spiral of the same bird. On f202V there is a complex procession of birds and quadrupeds where each motif stretches over two registers of the pattern, the head and neck forming the diagonals of the first unit, the body coiling into the second.

In the Book of MacRegol on f84V and the In Principio erat Verbum page (Masai 1947, Pl XXX; Hemphill 1911, Pl. IV) there are panels consisting of interlocking 'C' scrolls with birds' head terminals. The birds' bodies form the spirals which terminate in the centre with a short diagonal leg. Using birds' head terminals in this way is similar to the 'S' scroll on Clonmacnoise I D 2.

Turning to Pictish sculpture there are also examples of birds and animals with spiralled bodies on the early Class II slabs. There are two isolated animals on Meigle I and on Aberlemno II there is an impressive bird procession which has much in common with Bealin C 4 and Clonmacnoise I D 2 (Allen and Anderson 1903, III, Figs. 310A and B, 227A; Curle 1939-40, Fig. 5). The Aberlemno motif is placed to one side of the cross on the front of the slab. It is planned on a large scale, almost equal to the entire length of the shaft, and therefore the dimensions in themselves may be compared with Bealin although the style of carving is less delicate. Like Clonmacnoise I each bird is formed from an 'S' scroll and like Bealin each bird stretches over two spiral units, the lower end of each spiral terminating in a hip and two feet. Each bird has four limbs rather than three as on Bealin. They bite at the body of the bird above. The units at the top and bottom are incomplete.

The ultimate origins and early development of Bird Processions and similar motives in Hiberno-Saxon art have been keenly discussed. Françoise Henry (1933, 63-5; 1965, 188-90, Fig. 25) traced its origin back to inhabited vine-scroll which she believed became gradually abstracted to form processions of birds intermeshed with spiralled vine stems, the vegetal element being finally abolished causing the bird's body to become extended to form the spiral. However, Åberg (1943, 120) and Bruce-Mitford (1960b 253-4) followed by Bakka (1963, 31-2) have argued much more plausibly that bird processions have their origins in the Mediterranean.

Bruce-Mitford (1960b, 253) has suggested that the bird processions in the Lindisfarne Gospels are 'clearly traceable to the unmixed bird processions of imported East Christian Canon Tables or textiles' and that once they had reached Britain these birds were adapted to Hiberno-Saxon taste as may clearly be seen on f26V where 'S' scrolls with zoomorphic terminals have been combined with interlaced birds whose necks form the diagonals to the spirals. It is a further developed and more complex version of the Lindisfarne bird procession which appears on the Farmen (Sondre) bucket (Henry 1965, Fig. 25c) and Bealin C 4. In this light the processions of birds with vine-scroll elements exemplified by the Birka pail (Bakka 1963, Fig 23) and the Stromness Mount seem merely adaptations of the essentially Northumbrian inhabited vine-scroll to Hiberno-Saxon taste which took place during the second half of the eighth century (Bruce-Mitford 1960b, 254).

Interlace Panels with Bird's Head Terminals Banagher D 1 and D 3 and Clonmacnoise I D 4 are interlace patterns with bird's head terminals similar to those found on the bird processions. Banagher D 3 has birds' heads almost identical to Bealin C 4 except that their crests are less emphasized. They hold interlace strands in their beaks in the same way as one of the Bealin birds holds onto its fellow's back leg. The birds' heads on Clonmacnoise I D 4 are also very similar although their crests are hardly visible while the almond shaped eye and a line between the head and beak are emphasized. The tiny birds' head terminals on Banagher D 1 hold strands in their beaks but they do not have crests.

Parallels for birds with strands in their beaks used as terminals for interlace panels may be found elsewhere. On the Kells South they form the terminals to a Turned D pattern holding their own necks in their beaks (Roe 1966, Pl III). They are crestless. In Northern Pictland on the narrow faces of Rosemarkie I are three interlace panels using bird's head terminals (Allen and Anderson 1903, III, Figs, 64, 65; Henderson 1978, 49-52). In one case the birds have small crests and hold interlace strands in their beaks. In the other examples the crests are absent and their beaks are empty. Birds' heads with hooked beaks and crests are also found in the Lichfield Gospels (Henry 1965, Pl. 89), where they hold their own necks in their beaks and similar crestless birds are found on the Barhaug Mount (Petersen 1940, 28, Fig. 21).

Anthropomorphic Motives Anthropomorphic motives are found on Banagher C 3 (Fig. 17) where the terminals to an interlace pattern are

anthropomorphic and Banagher A 3 where the entire panel is decorated with interlaced men. The seated figure on Clonmacnoise I D 3 is also an unusual version of an anthropomorphic motif. The carving on Clonmacnoise I B 1 is badly weathered but it is possible that an anthropomorphic motif was once represented since the two appendages at the bottom have the appearance of human legs.

The best parallels for Banagher A 3 and C 3 undoubtedly come from manuscript illumination and especially in the Book of Kells where countless human figures have been incorporated into the ornament. The use of men's heads for interlace terminals may be seen on the small panel on f33R (Henry 1974, Pl. 108). There are men placed one above the other in many of the long thin panels of the canon tables (eg f3V, f1V and f2R). These figures may be closely compared with both Banagher panels as they too have thin elongated bodies, flat tops to their heads and frequently long hair, beards and forelocks which have become extended into interlace strands which they clutch in their fists. Like Banagher A 3 their long thin legs are frequently flexed rather than extended. For the most part these figures are interlaced with delicate tendrils rather than with one another but in wider rectangular and circular panels there are examples of complete anthropomorphic figures with their limbs interlaced. One example on the chi-rho page (f34R; Bain 1951, 115) shows a rectangular panel with two pairs of seated figures, their legs interlaced and their long forelocks and beards interlaced. They hold their beards in their clenched fists. Another example, f253V, (Fig. 17) shows two confronted interlaced men, their forelocks interlaced and one with his legs in a very similar position to Banagher A 3. The detail of the way the hair and beard tendrils loop round the men's arms and are caught up in their hands on A 3 is closely paralleled on f2V where the figure of God at the top of the canon table is confronted either side by a lion. He grasps their lolling tongues, which loop round his wrists, in His hands.

The Banagher panels may also be compared with the anthropomorphic ornament in the Book of MacRegol (Henry 1965, 199) though here the design and style of the illumination is much less accomplished than in the Book of Kells. The page at the beginning of St. Mark's Gospel (Hemphill 1911, Pl II) shows two rectangular panels containing two men (Fig. 17). Their heads are at either end of the panel; their long, thin legs, are flexed, one extended as an A 3, interlace in the centre. Their bodies are foreshortened and their heads large but they have long hair, forelocks and beards which curl into fine interlace tendrils in the manner of the

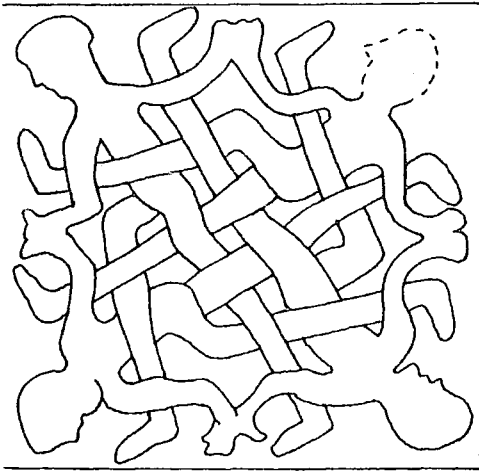

1

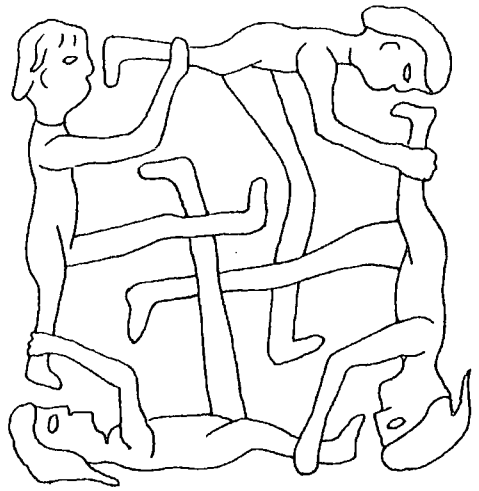

2

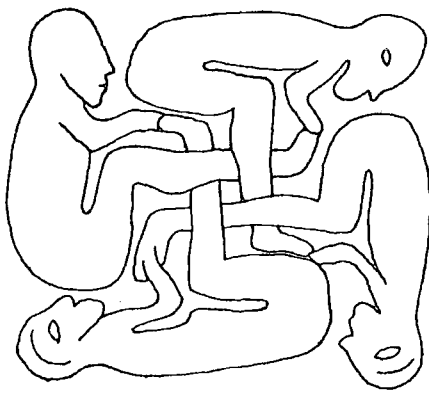

3



4

Fig 17.2

1 AHENNY I A 2

2 MARKET CROSS, KELLS

3 MEIGLE XXVI

4 TOGHERSTOWN MOUNT

5 OLD KILCULLEN

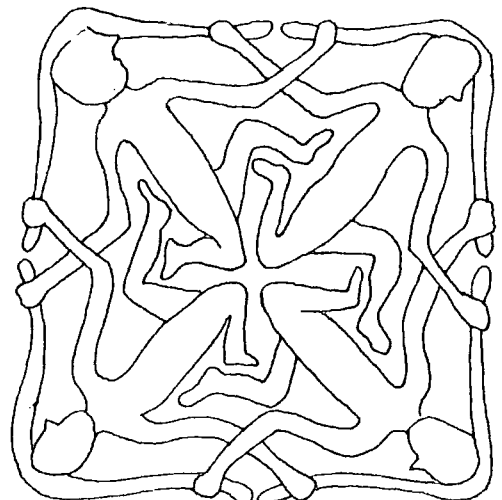

5

Banagher panels. They have prominent noses and large almond shaped eyes which are characteristic of A 3.

There are examples of patterns incorporating anthropomorphic designs on both Irish and Pictish sculpture but their stylistic affinities are less close to Banagher A 3 and C 3 than manuscript illumination. Kells South provides one comparison (Roe 1966, Pl. IV, 19). On the west face are two confronted men with their bodies and limbs interlaced. They pull each other's long beards. This motif is repeated on the Kells Market cross (op cit, 34). The cross at Old Kilcullen provides a further comparison (Fig. 17). Four figures, their heads in the corners as on Banagher A 3, are placed so as to form a cruciform shape in the centre of the panel although in this case their legs do not actually interlace and therefore have a foreshortened appearance. Like Banagher A 3 also their heads are in profile¹⁰ and their long hair is caught up in the hand of the man on either side. The Old Kilcullen panel is much simpler than Banagher A 3. This is necessitated because the stone is granite but a similar panel on the sandstone cross Ahenny I A 2 (see p 115) (Fig 17) is also simplified, the lacertine details of the beard and hair having been totally eliminated. There is a further simpler variation on the Kells Market cross (Henry 1932, Fig. 46d). In Southern Pictland there is one example of a simple anthropomorphic pattern on Meigle XXVI (Allen and Anderson 1903, III, Figs. 318B, 319).

In metalwork anthropomorphic motives are not common. However a fragmentary Hiberno-Saxon gilt bronze mount from Halsan in Norway may be reconstructed to show a design which is comparable in many aspects with the Banagher panels (Bakka 1965, 39, Figs 4-6) (Fig. 17). The mount is rectangular. Four men are shown, two at either end, with their legs interlaced in the centre and their heads bent forward. The shape of the head is very similar to Banagher C 3 being flat on the top with a pointed chin. Here there is no forelock or beard but the strand of hair at the back has been extended to form a plaitwork motif. A second good comparison has recently come to light in the Derrynavlan hoard. One of the gold filigree mounts on the rim of the paten (Ó Riadaín, B. 1980b, 18) shows two adorning kneeling figures. Their long hair locks are interlaced and their beards also form interlace ornament. The only other known metalwork piece incorporating interlaced men is a gilt brooch from Togherstown, Co. Westmeath (Mahr 1932, Pl. 19.4) (Fig. 17).

Banagher A 3 may also be compared with the 'motif piece' showing anthropomorphic ornament from Garryduff (see p 17).

Clonmacnoise I D 3 shows a figure seated face on with mask-like facial features. Although the panel is badly weathered strands may be seen issuing from the figure's head. These, which have been interpreted as stag's antlers, together with the face-mask have led to the belief that this panel may have pagan connotations in a Christian context (Henry 1965, 155; Ross 1967, 147). Anne Ross draws far ranging comparisons between the Clonmacnoise representation and depictions of the Celtic god Cernunnos, the lord of the animals, who is shown on the Gundestrup Cauldron in a cross legged position with mask-like features and antlers crowning his head (Hatt 1980, Pl. 2). This comparison seems far fetched since the 'antlers' on Clonmacnoise I D 3 are probably illusory. Françoise Henry has sought equally suspect parallels for anthropomorphic interlace patterns in objects, such as an ancient bronze from Luristan, which are far removed from the Hiberno-Saxon milieu (1933, 85, Fig. 45a; 1967, 91, Fig. 9a).

It is much easier to discuss Clonmacnoise I D 3 with Banagher A 3 and C 3 as a development of the Hiberno-Saxon artist's love of elaborating birds and animals by interlacing their bodies and enhancing the design with a fine mesh of strands. The addition of men to this kind of ornamental repertoire may first be recognised in manuscript illumination in the Book of Kells where anthropomorphic patterns of the type already discussed are frequently included and human figures are also frequently used to fill up spaces or weave in and out of the letters (e.g. f188R; Henry 1974, 200). The best parallel for Clonmacnoise I D 3 is provided by an anthropomorphic motif from the Turin Gospels (Turin Univ. Lib. MS O.IV.20) which Françoise Henry (1967, 95-9) sees as an early ninth century continuation of the luxury manuscript tradition. One of the two surviving carpet pages shows two rectangular panels each containing a face on figure (op cit, 97; Henry 1964, Fig. 30). The head has the same mask like appearance and staring eyes as Clonmacnoise I D 3. Likewise bunches of fine interlace strands issue from his head to fill the spaces on either side. The figure's arms cross in the same way but he does not have any legs; a pair of adorned birds, their necks interlaced with the figure's arms, are adopted instead.

However, one cannot completely ignore Anne Ross' comparisons between the figure on Clonmacnoise I D 3 and pagan Celtic representations. The mask-like face is a characteristic feature of pagan Celtic art. The cult of the head is an important aspect of pagan Celtic religion (see p 22) and carved representations of the head with its mask-like features are common

throughout Celtic Europe. There are a number from Ireland which may be exemplified by a group currently housed in Armagh Cathedral (Ross 1967, 113-8, Pls 39, 40a). Anne Ross emphasizes the difficulty of dating the Irish material because the human face-mask remains a persistent feature which is still used in the Irish Romanesque, for example on the door at Clonfert Cathedral (see p244). However, rather than a clear retention of pagan ideology in a Christian context, it is far more likely that the conventions for representing the human head in Pagan Celtic art survived, as did the spiral, throughout the Early Christian Period and were quickly adapted for use in a Christian ornamental repertoire. This adaptation is most clearly shown by Christ's face on the Athlone Crucifixion plaque (Henry 1965, 204-5, Pl. 46). Other examples are provided by the face-mask on the Oseburg bucket, which may be a secular or religious object, where the escutcheon is formed from a small human figure seated cross-legged in a very similar manner to the figure on Clonmacnoise I D 3 (Petersen 1940, Fig. 94; Henry 1965, Pl. 91) and the crouched figure on the Copenhagen Mount (Fig. 13) (Wilson 1955, 165-6). In sculpture the retention of the pagan style of figure representation into the Early Christian Period may be seen on a number of monuments among them the ecclesiastic with his bell, book and crozier on one of the Carndonagh pillars and the White Island statues (Henry 1965, 130; 1967, Pls. 12-14). Helen Hickey (1977, 12) says of the man who carved the White Island figures that he was a 'local sculptor whose particular genius lay in the way he blended new ideas from Christian iconography with earlier sculptural modes'. Therefore Clonmacnoise I D 3 should probably also be seen in the light of this adaptation of the pagan Celtic style of figure representation into the Christian context.

The figure may also be compared with a small anthropomorphic figure with raised arms, a double fish tail and a series of curly tendrils sprouting from its head on Meigle XXII (Allen and Anderson 1903, III, Fig. 350). The pagan connotations suggested for this seem equally unfounded (Ross 1967, 140).

Inhabited Vine-Scroll Vine-scroll, inhabited or otherwise, is unusual on Irish sculpture. Amongst this group there is a single example on Clonmacnoise IV C 3. This panel may be closely compared with an inhabited vine-scroll pattern on Kells South (Fig 18). Each consists of five registers of pattern. The vertical height of the two panels is almost identical (Clonmacnoise IV 57 cm, Kells South 58 cm) but Clonmacnoise IV

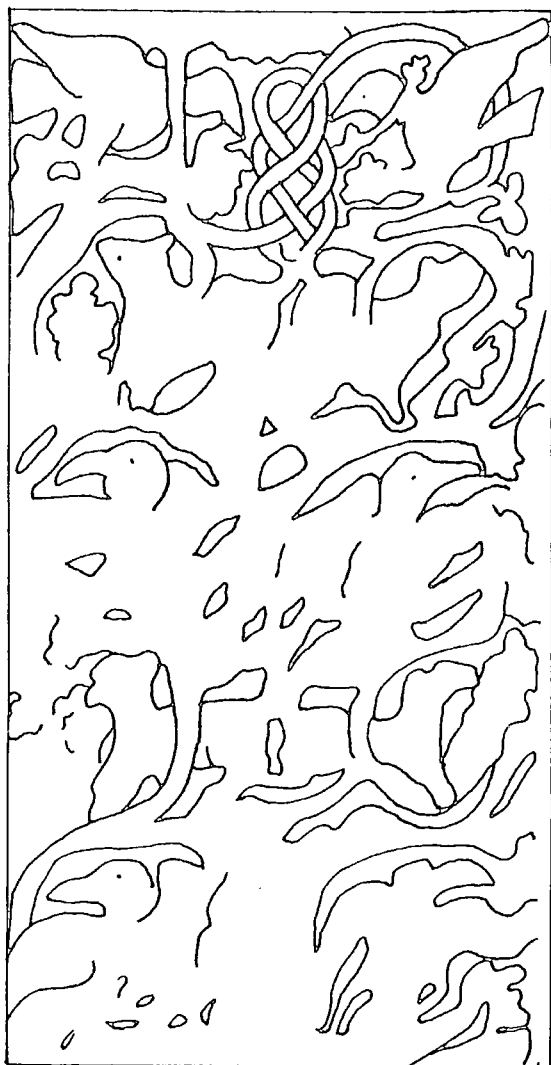

1



2

Fig 18

INHABITED VINE
SCROLL

1 CLONMACNOISE IV C 3

2 SOUTH CROSS, KELLS

(after Henry)

3 BOOK OF KELLS

(after Henry)

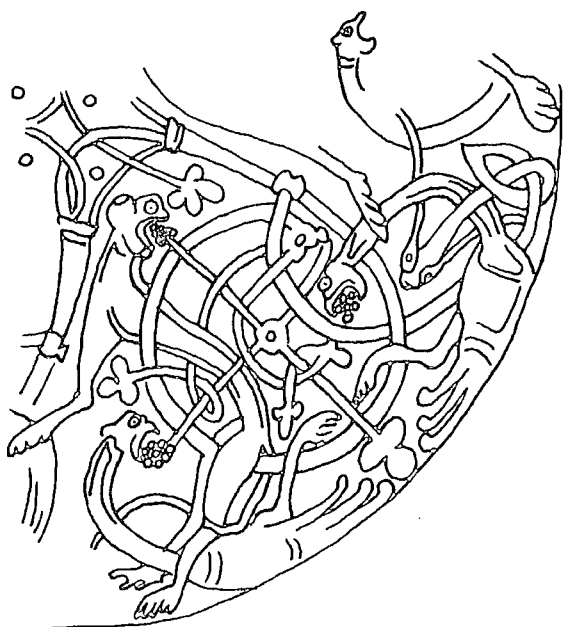

3

is 4cm wider than Kells South (28 cm; 24 cm) which possibly accounts for the introduction of a small area of plaitwork at the top of the panel. On Clonmacnoise IV C 3 the registers are very closely set whereas on Kells South only the top register is squashed. On Kells South the vine springs from a triangular knot; this is too weathered to see on Clonmacnoise IV but on both the central stem of the vine is not continuous after the first register. On both also each register is formed by two plant stems which each encircle a bird or quadruped which is shown pecking at berry bunches. The birds and quadrupeds are similar on both monuments except that the Clonmacnoise IV quadrupeds have shorter legs, probably owing to lack of space. The two panels therefore are very alike suggesting that a similar if not identical model was used for both.

Other examples of inhabited vine-scroll may be seen on Old Kilcullen and Monasterboice South (Macalister 1946, Pl. VI). The former is dissimilar but the latter shows a simplification of the two panels already discussed. This well illustrates the conservatism of the Irish sculptor; once a model was adopted it seems to have been little changed. Related inhabited vine-scroll motives may also be seen on Durrow I B 11 and Clonmacnoise V B 13 and D 13 (see p 245).

There is a noticeable lack of actual vegetation on either the Clonmacnoise IV or Kells South panels. However, in the top right hand corner of Clonmacnoise IV C 3 is a single trefoil shaped leaf. This leaf type is unparalleled either in the Northumbrian sculptural vine-scroll (Cramp forthcoming, Fig. 9) or on the few Pictish examples (Bakka 1963, 33, Note 71; Crawford, O.G.S., 1936), although it is found on the Mercian architectural vine friezes at Breedon (Cramp 1977, Fig. 50). It seems more characteristic of some of the foliage in manuscript illumination, particularly that in the Book of Kells¹¹. In this manuscript there are several different versions of vine-scroll (e.g. f188R, f19V, f202R) but at no time is its form very close to that of Clonmacnoise IV C 3, perhaps because the rectangular shape of the sculptural field does not really lend itself to the complexity of forms found in manuscripts. However, a number of details do correspond including the trefoil shaped leaves and the shape of the berry bunches. On f188R (Fig. 18) the birds with their hooked beaks and the facial features of the quadrupeds are also comparable though the limbs of Book of Kells creatures have been elongated and twisted round to complement the flowing composition of the roundel. The small rectangular panels on f129R show a single register of vine scroll with trefoil shaped leaves with two stems issuing from a vase, each surrounding one of a pair

of confronted birds with hooked beaks.

Trefoil shaped leaves are also found on foliage ornament on some of the mid eighth century Anglo-Saxon manuscripts, for example the Barbarini Gospels (Vat. Barb. lat. 570) (Henry 1974, 214, Fig. 66), usually associated with Lindisfarne, and the Leningrad Bede (Publ. Lib. Q.v.1) associated with the Jarrow-Wearmouth Scriptorium and dated 731-5. Meyer Schapiro (1958, 193-4, Pl. 23b and e; Ward-Perkins 1937, Pl. XXXII 1 and 2) has suggested that the origins of this type of vegetal ornament may be found on seventh century Visigothic sculpture.

As Egil Bakka (1963, 32, Note 71) has pointed out vine-scroll is primarily a Northumbrian motif, probably only being adapted to fit the Hiberno-Saxon ornamental repertoire at a later date. The form of the inhabited vine on Clonmacnoise IV C 3 may be seen as a development of the bush and tree vines found mainly on Northumbrian sculpture. The trunk divides into a number of branches at the top of the first register but, because of the height of the panel, the central axis of the vine is abandoned and the branches simply pass back and forth across the centre of the panel curving round to form perches for the birds and animals. The form of the vine, the delicate rendering and the small scale of the representation may be compared with the fragmentary cross shaft from Croft, North Yorkshire (Kendrick 1938, 149, Pl. 61). Here, on one broad face, is a tall scroll of three registers rising from a triangular root. Alternate registers are occupied by pairs of birds and quadrupeds. The pairs of birds with open wings and hooked beaks are mirror images of each other. They peck at small berry bunches. Like Clonmacnoise IV C 3, the vegetation is reduced to a minimum, the spear shaped leaves being used as fillers. On the other broad face are two further vine-scroll panels. The upper shows two birds enmeshed in a bush vine; the second shows the abandonment of the structure of the vine so the birds and quadrupeds merely perch amongst the vine stems rather in the manner of the upper registers on Clonmacnoise IV C 3. Rosemary Cramp (1978, 8, Fig. 1.1e) sees such 'miniature animated carvings' as the adaptation of oriental animals and plants to already established idioms in the first quarter of the ninth century.

In metalwork one possible comparison is provided by the Ormside Bowl which has pairs of mirror image birds and quadrupeds perched amongst the vine stems¹². In a Hiberno-Saxon milieu the Birka Pail provides a more abstracted version of such vine motives (Bakka 1963, Fig. 23; Henry 1965, Figs. 25a and b) again executed on a small scale and in a delicate engraved technique. The upper frieze shows a vine with a central trunk expanding

into a half circular knot at the bottom. Two pairs of vine stems project from the trunk, each pair being inhabited by two birds with hooked beaks, one the mirror image of the other. Below is a procession of birds encircled by vine stems again showing the abandonment of the strict vine structure. The part played by the foliage is insignificant.

Conclusions Thus zoomorphic ornament and related motives are an important and characteristic aspect of the Clonmacnoise Group. The variety and complexity of these designs are striking and are unrivalled by other groups of Irish sculpture. It is noticeable that the models used by the sculptors for such motives do not seem to be sculptural. As Françoise Henry (1967, 195-6) has pointed out, like interlace, key and spiral patterns in the Vernacular Period, zoomorphic motives in this case are common to sculpture, metalwork and manuscripts.

Undoubtedly the most important comparisons may be made with manuscripts and particularly with the Book of Kells which shows the constant employment of a number of the same motives, especially anthropomorphic designs. The influence of manuscripts may also account for both the complexity of conception and the fineness of line found on some of the Clonmacnoise zoomorphic motives.

These two features are also characteristic of the Hiberno-Saxon metalwork objects decorated in an engraved technique which have been frequently alluded to. One or two comparisons have also been made with Hiberno-Saxon metalwork objects of the more plastic style characterized by the Romfohjellen mount.

The locus faciendi of the metalwork and manuscripts which use these motives has been constantly disputed (Appendix 2), so the adoption of such designs on the Clonmacnoise monuments must therefore provide one of the few fixed points where these motives are known to have been part of the ornamental repertoire. This, however, does not mean the motives are Irish, they are rather characteristic of the Hiberno-Saxon milieu. There is one exception to this, inhabited vine-scroll. It cannot be included with the rest as its Northumbrian origin is plain and its Hiberno-Saxon adoption is probably later and of a rather 'episodic character' (Bakka 1963, 33, Note 71).

c) Spirals

Spiral patterns, although not extensively used on the Clonmacnoise monuments, are nevertheless, characteristic, being found on Bealin, Banagher,

Clonmacnoise II and Clonmacnoise IV. There is no spiral ornament on Clonmacnoise III and the only example on Clonmacnoise I is a row of incised 'C' scrolls used as a filler on B 1.

Bealin, Banagher and Clonmacnoise II The spiral patterns on Bealin D 4, Banagher B 2 and D 2 and Clonmacnoise II A 1 are all variations on the same double border pattern. These patterns seem to have been constructed on square grids (see p 13) and in each case a vertical line is clearly visible down the centre of the panel and on Bealin D 4 and Banagher B 2 and D 2 the spirals have been squared at the corners of the panels. On Bealin and Clonmacnoise II it seems possible that similar constructional grids could have been in use. On Bealin the horizontal distance between the centres of the spirals is 10.25 cm; on Clonmacnoise II it is 15.5cm, that is approximately half as much again. On Banagher the patterns are on the narrow faces of the shaft and are therefore on a much smaller scale. Here a 3cm unit measure seems likely which, of course, is frequently used for the interlace ornament on these monuments (see p 50).

The style of carving and the details of the ornament on Bealin D 4 and Clonmacnoise II A 1 may be closely compared. The field has been cut away to a consistent level leaving delicate spiral strands in low rounded relief. The slashes on the expansions tend to be cut more deeply than the field. The closest parallel for this double border pattern is provided by Tihilly D 3 (see p 178) and there is a further example on the South Pillar, Carndonagh (Henry 1933, Pl. 7).

The striking feature about Bealin D 4 and Clonmacnoise II A is the details of the vegetal ornament. In each case the outer 'S' scroll expansions are leaf shaped. On Clonmacnoise II they appear to actually grow from a stalk and then drop forward over the line of the 'S' scroll terminating in a small knob. The spiral terminals on Clonmacnoise II are slashed so as to give almost the appearance of berry bunches. On this too the curious shape of the 'C' scroll expansions with their funnel shaped slash marks and the round knob hanging down from the centre seem to have a flower-like quality and at the bottom of the panel the small projections either side of the spiral strands are reminiscent of the point where a plant stalk issues from the earth.

Although the vegetal details, especially leaf shaped expansions are frequently found elsewhere in spiral ornament from the Turœ stone onwards (Duignan 1976) their concentration here is unusual and certain details which recall vine-scroll, the spiral terminals, which have the appearance of berry bunches and the triangular projection at the base of Clonmacnoise II A, cannot be totally ignored. While it is possible that these vegetal

details may have been adapted into the spiral pattern simply because they appealed to the sculptor it could also be interpreted as a method by which the Hiberno-Saxon artist might adapt vine-scroll into a Celtic ornamental repertoire. Both Egil Bakka (1963, 32) and Françoise Henry (1965, 188) have discussed this 'style creating factor' which transformed such motives as the Germanic Style II animal to suit Hiberno-Saxon taste (see p 63). There are a number of Hiberno-Saxon objects which show the stylization of vine-scroll. These may be exemplified by the Birka Pail with its spiralled vine-stems (Raftery, J. 1941, pl.103). The vegetation, which is used merely as a filler, and the roots on the upper vine frieze may both be compared with Clonmacnoise II A. A similar spiralling of the vine stems, which terminate in berry bunches, is found on Duleek North (Crawford, H.S. 1926b, Fig. 1). In manuscripts Françoise Henry (1974, 205) has drawn attention to the 'vegetable aspect' of the spiral ornament in the way it spreads across the page in the Book of Kells. She has also suggested (1967, 91-2) the possible interchangeability of the spiral and vine-scroll motives¹³ in the mind of the Celtic artist while the symbolic eucharistic meaning of the vine is retained. It seems possible that this could also be true of the spiral ornament on Bealin and Clonmacnoise II.

Clonmacnoise IV The spiral ornament on this cross is rather different from that already discussed. Two different types of spiral ornament are used. On C 2 and B 8 the spirals are raised into bosses while in contrast the background ornament on the crosshead of face A is in very low relief.

The characteristic features of C 2 and B 8 are the bosses decorated with an interlace mesh, the incised 'S' and 'C' scrolls and the small slashed triangular and spiral expansions. The pattern of C 2, set on the diagonal (see p13), is common amongst the Ossory crosses for example Ahenny I C 2, Ahenny II A 7 and 8 (see p101) although the style of execution is completely different. B 8, however, may be compared with Kinnitty I D 2 and Tihilly B 3 and here the stylistic details are very similar. A similar pattern is also commonly found in the Book of Kells (eg f4V, f5R).

The important feature of these patterns is the meshed bosses. The best parallels for these are to be found in Scotland in the distinctive 'Boss Style' and it seems likely that elements of this style could have been passed on to Ireland from here.¹⁴ Flat roundels decorated with a tight interlace mesh similar to Clonmacnoise I A 1 are paralleled amongst

the early Class II slabs of Southern Pictland at Glamis II and St. Vigeans VII (Allen and Anderson 1903, III, Figs. 234A, 278). The same feature may be seen in Northern Pictland on the more highly developed Class II slab at Hilton of Cadbol (op cit Fig. 59) which Stevenson (1955, 116) dates c 800 although Isobel Henderson (Pers. Comm. April 1977) would tend to see it as earlier. The fully developed high relief 'Boss Style' is represented by Nigg in Northern Pictland and Aberlemno III and the St. Andrew's Sarcophagus in the south (Allen and Anderson 1903, III, Figs. 72, 228A and 365). One of the characteristics of these three monuments is the high relief bosses decorated with interlace mesh similar to those on Clonmacnoise IV. However, here they are not associated with spirals but either appear singly surrounded by a raised moulding, as on Aberlemno III, or combined with writhing snakes (see p 99) as on Nigg and St. Andrews. Meshed bosses, sometimes accompanied by snakes, are also a prominent stylistic feature of the Ionan sculptural workshop where they are particularly found on St. Martin's Cross and the cross at Kidalton, Islay (op cit, Figs. 397B, 410).

In Irish sculpture smaller bosses combined with spiral ornament are a feature of Kinnitty I C 1 (see p 177) and bosses combined with snakes are characteristic of many of the 'Scripture' crosses (see p243).

In contrast the spiral pattern used as a background ornament to the bosses on the crosshead of A 1 is carved in very low relief. The pattern is now impossible to reconstruct but such a pattern successfully solves the problem of how to ornament an irregularly shaped area. The closest parallel for this is provided by Ahenny I A 1 (see p 100) which shows an identical use of spiral ornament although the style of carving is completely different. There is a long tradition in Irish sculpture of covering large areas with a carpet of spiral ornament which may early be seen on La Tène monuments such as the Turoe and Mullaghmast stones (see p 21).

Conclusions Therefore three distinctive styles of spiral ornament are found on the Clonmacnoise monuments. Bealin, Banagher and Clonmacnoise I have spiral panels carved in delicate low relief, the details of the pattern being reminiscent of vegetation. However, the spiral ornament on Clonmacnoise IV is completely different consisting of spiral patterns raised into meshed bosses which may be compared with Scottish 'Boss Style' and a carpet of spiral ornament in very low relief.

d) Step Patterns

Step patterns do not form a major part of the ornament of the



Clonmacnoise group. In fact there are only two examples, Bealin B 2 and Clonmacnoise II B 1. These panels are not prominently placed.

The lengths of the steps (see p 16) on Bealin B 2 are surprisingly uneven suggesting it may have been drawn out freehand. However, the lengths of the steps are more consistent on Clonmacnoise II B 1. The width of the step is approximately 1.5 cm, the length being somewhat longer in places in order to fill the required length of the panel. 1.5 cm. is a common unit measure for the Clonmacnoise interlace ornament (see p 50) and this may be related. The panel is probably unfinished, since, although the cruciform centres of the lower panel have been sunken, the rest of the pattern is merely incised.

The origins and use of step patterns have already been discussed (see p15). Suffice it here to draw attention to close parallels. The way in which Bealin B 2 has been executed with the lines of the steps standing out in low relief while the background has been cut away to a consistent level is reminiscent of metal working techniques and in particular it may be compared with the step pattern on the front of the Emly house-shrine, an object of known Irish provenance. Joseph Raftery (1941, 109) has suggested a date of c 750 while Swarzenski (1954, 62) has suggested it could be as early as the late seventh century. Swarzenski (op cit, 60) has also remarked upon the uniqueness of the technique used for the execution of the step pattern on this shrine. The lines of the pattern have first been cut out of the wood and then silver hammered into them so that it protrudes, giving a contrasting effect between the shining silver and the dark wood. A very similar effect is achieved in Bealin when oblique sunlight shines on the relief lines of the step pattern set against the darker cut away background and such an effect might originally have been accentuated with the use of paint. Other comparisons may be made with glass studs such as that from Lagore (Hencken 1950-1, 129-30) which was made by placing a metal grille into a mould and then dropping molten glass on top (Henry 1965, 95, Pl. 36) thereby producing a similar effect. In manuscripts step patterns showing a similar contrast between the line of the pattern and the background may be seen on the David as Victor page of the Durham Cassiodorous (Durham Cath. Lib. MS B.II.30) (Nordenfalk 1977, Pl.28).

e) Fret Patterns

Amongst this group fret patterns are only found on Clonmacnoise IV where they are used fairly prolifically being found on B 1, B 5, C 4, D 6 and D 11 and as the background ornament on the crosshead C 1.

Three different kinds of pattern may be noted. The first of these is a border pattern of interlocking fret elements on B 5 and C 4. The first of these, a half  pattern (RA Nos. 926-9) is fairly common on both manuscripts and sculpture throughout the British Isles over a long period and therefore close parallels are difficult to suggest. However close parallels may be cited with an identical pattern on Kells South (Roe 1966, Pl. V) and there is also a similar pattern on Monasterboice South (Macalister 1946, Fig. 13, Panel 53). In metalwork the same pattern forms a border to the interlace pattern on the Phase I part of the Domnach Airgid (Henry 1965, Pl. 55, Bakka 1963, 30). The pattern on C 4 is rather unusual. It is a rather crude design of  elements where the terminals have become curved.

The second type is a border pattern consisting of a number of different units placed side by side and is found on D 6 and D 11. A single fret pattern unit is found on B 1. It may be that the practice of placing fret units side by side rather than interlocking them may have arisen in order to keep the pattern simple. This practice is also found on Ahenny I A 1 and a similar style of execution is also used, each element being outlined in relief leaving the centre cut away, a sharp metallic effect being produced thereby (see pl12). There are parallels on Kilree D 7 and on f3V in the Book of Kells and there is a more complex version on Monasterboice South (Crawford, H.S. 1926a, 39; Macalister 1946, Fig. 13, Panel 63).

The pattern on C 1 is in similar low relief to the spiral pattern on A 1. The exact nature of the pattern is difficult to be sure of but it seems to be a rare example of the use of the fret element . The only other Irish example is on the East face of Castledermot South (Henry 1932, Pl.46). A fret pattern used in this position on the crosshead is also unusual, the only other examples being again Castledermot South, where there are no bosses and so three border patterns have been simply linked together to fill the entire crosshead, and the crude ringless cross at Kilbroney, Co. Down (Henry 1964, Pl.26). The use of fret patterns on the crosshead is more popular in Pictland. There are examples of straight line spirals on the early Class I slabs, Aberlemno II and St. Vigeans VII, and on more developed Class II monuments at Dunfallandy, Fowlis Wester and Meigle II it is combined with bosses on the crosshead (Allen and Anderson 1903, III, Figs. 227A, 278, 305A, 306A, 311A; Henderson 1978, 53).

4) Beastsa) Lions and Griffins

Several examples of these two beasts are depicted on the Clonmacnoise monuments. The lion is found on Bealin C 4, Clonmacnoise I D 1, Banagher A 1 and C 2 and Clonmacnoise III A 1, the griffin on Bealin C 3, Clonmacnoise I B 1 and probably Clonmacnoise III A 1.

The lions on Bealin C 4 and Clonmacnoise I D 1 are closely comparable except that in the latter version the curl of the upper lip has been reduced to a knob. The lion on Banagher A 1 is also similar but is more prominently placed, is on a larger scale, its head is square and its body less arched. The size of its paws has also been accentuated. This stylistic feature is characteristic of manuscript illumination from which it is probably derived. Examples may be seen in the Book of Kells (e.g. f271R) and the Book of Armagh (Dublin R.I.A.) (Henry 1974, Fig. 51). Another sculptural example may be seen on Tihilly D 2 (see p 174). The second lion on Banagher C 2 is much smaller. The extension of its tongue and possibly its mane and tail into lacertine knots acting as fillers is also suggestive of manuscript influence, examples of which may be seen in the Durham Cassiodorus (Bailey 1978b, 20, Fig. 6; Nordenfalk 1977, Pl. 27) and the Book of Kells (f24R, f33R; Henry 1974, 207-8).

The griffins bear many of the same physical characteristics as the lions. The griffin on Bealin C 3, except for its bird-like head with prominent beak, is almost indistinguishable from the lion on the same cross. The positioning of this creature, like the placing of the interlace panels on the crosshead of Face C, seems rather curious. Presumably the lost motif on the right hand horizontal cross arm would have balanced the ornament but the fact that the griffin faces left, that is away from the centre of the crosshead, is surely unexpected. On other crosses the ornament of the crosshead is either organised as a whole, for example Ahenny I (see p100), or, as on the 'Scripture' crosses the figural scenes are designed to focus attention on the centre of the crosshead.¹⁵

On Clonmacnoise III A 1 the bodily stance of the beasts is identical and repetitive. Equally the beast types have become somewhat muddled and it is rather difficult to tell whether lions or griffins are intended and it seems possible that the sculptor may have been copying, rather badly, beasts already available to him on other Clonmacnoise monuments. The leonine creature at the top of the shaft has an almost identical stance to

the lion on Banagher A 1 although on Clonmacnoise III the floriate tail is longer and the jaws are closed. The beast below, which turns its head to grasp its tail in its beak, is similar to the griffin on Clonmacnoise I D 1, which turns its head to grasp the leg of the creature above. A similar beast has been squashed onto the bottom of the shaft.

These lions and griffins are likely to have been imbued with Christian symbolism although their exact meaning or meanings in this context are difficult to tell. The lion is chiefly a symbol of strength, strength that can be turned to good or evil. The Early Christian Fathers sometimes associate the lion with Christ (Cadbrol and Leclercq 1907-53, IX.1, 1198-9). In other contexts it is definitely a symbol of evil as, for example, when David, a pre-figure of Christ, is shown breaking the jaws of the lion (see p149) (Réau 1955, 92 ff) Christ may also be shown trampling the beasts including a lion. In other Early Christian texts the lion took on different values. In the Physiologus it symbolizes the Incarnation (see p163) while in Byzantine theological writings it is associated with the Resurrection. The lion is also associated with the tribe of Judah (Cadbrol and Leclercq 1907-53, IX.1, 1199) and is the Evangelist symbol of St. Mark although the latter meaning seems unlikely in this context as the Lion of St. Mark is shown with wings in other representations on Irish sculpture at Kells South and Duleek North (Roe 1966, Pl. V; Crawford, H.S. 1926b, Fig. 1).

Griffins, although primarily an ancient mythical beast, do come into Christian iconography where they seem to be associated with both Christ and the Devil although the latter seems more usual (Réau 1955, 88, 117; Cadbrol and Leclercq 1907-53, VI.2, 1814-8).

There are a number of other Irish and Pictish monuments which include lions and griffins in their repertoire. In Ireland there are two slender feline creatures with squared jaws which have very much the appearance of lions on Gallen Priory I (see p266), two elegant lions on Tybroughmey B 2 and C 1 and other possible examples in Roscrea I C 1 (see p160) and Lorrha I C 4 (see p121) as well as those depicted in representations of Daniel in the Lions' Den (see pp 121,147). On Pictish monuments the species of beasts represented is frequently difficult to be sure of but lions may be securely identified on Pappil, Golspie and Glamis II (Allen and Anderson 1903, III, Figs. 6, 48 B, 234A). The curious shape of the feet of the Glamis II lion, a distinctive feature of Pictish animal representations (see p161), is also found on the lion and griffin on Bealin. In Pictland the griffin is quite commonly represented particularly on monuments from Meigle and St. Vigean. There is a particularly lively example on Meigle XXVI (op cit,

III, Fig. 318C).

In manuscripts the lion but not the griffin is a distinctive ornamental element in the Book of Kells (Henry 1974, 206-7). These lions, though considerably more elegant, with their pointed ears, large almond shaped eyes, spiralled snouts and curly manes, have many features in common with those on the Clonmacnoise monuments (eg f3R, f187V, f212R).

In Anglo-Saxon England Rosemary Cramp (1978, 13) has commented on the introduction of exotic oriental beasts into the sculptural repertoire during the last quarter of the eighth century and their continued use during the ninth and tenth. The influx was due to the opening up of Western Europe to Eastern influences as a result of the re-establishment of Orthodoxy by the Empress Irene (op cit, 8). The lion and the griffin became popular motives on both Northumbrian and Mercian Sculpture. The types may be exemplified by the prancing lion at Breedon (op cit, Fig. 1.2; Cramp 1977, 206-7), the more classical winged lion entangled in a vine at Dacre (Collingwood 1927, Fig. 58) and the Otley griffins (Cramp 1978, Fig. 1.2).

On the Continent examples of exotic beasts are found in the sculptural repertoire of eighth century Lombardic Friuli (Hubert et al 1967, 247) and seventh century Visigothic France, for example a lion carved on a stele from Oupia (Durliat 1953, 100, Pl.3) and two confronted griffins on a sarcophagus at Charenton-Sur-Cher (Le Blant 1886, Pl. 15). There are also many examples of griffins, sometimes drinking out of vases, on barbarian style brooches from Gaul, Germany, Switzerland and Northern Italy. Some include definite Christian symbolism (Cadbrol and Leclercq 1907-53, VI.2, Figs. 5469-5474).

However, the ultimate origins of these lion and griffin motives would seem to lie in the East. In what precise form they reached the west is difficult to be sure of but designs on textiles or similar portable objects seem likely. These may be exemplified by a sixth or seventh century textile depicting pairs of confronted lions found at Sancta Sanctorum in Rome (Dalton 1911, Fig. 373). Quite how such models reached Ireland is unknown. The Clonmacnoise sculptors may have been open to the same oriental influences as their Northumbrian and Mercian counterparts. After all it is known that St. Cuthbert's body was wrapped in oriental textiles (Battiscombe 1956, 484-525) and Irish churchmen could have acquired similar objects. However it is also possible that the Irish did not receive the impetus directly from the Continent or the Mediterranean but rather via Anglo-Saxon England and Pictland.

b) Fantastic Beasts

Amongst the Clonmacnoise monuments there is a single example of a fantastic beast on Clonmacnoise I B 1. This four legged bird cannot be identified as any particular mythical species but it may be compared with the fantastic beasts discussed in connection with Roscréa I and Tybroughney (see p161) and it probably originates from a similar source.

5) Figural Iconography

Figural scenes are little used amongst the Clonmacnoise group. They may be divided into two types, horsemen and hunting scenes and Scriptural iconography.

a) Horsemen and Hunting Scenes

Only one hunting scene may be securely identified on the Clonmacnoise monuments, that is Bealin B 3. Otherwise there is a horseman and a stag on two separate panels on Banagher A 1 and A 2, a horseman on Clonmacnoise III A 1 and there are traces of horsemen on Clonmacnoise IV A 7 and C 7.

Bealin B 3 is inconspicuously placed at the bottom of the shaft on a narrow face. Such a position is unusual as hunting scenes on Irish crosses are usually found on the base (see p124) (it is unknown whether Bealin ever had a base) though there are also three examples of its placement on the crosshead (see p152). One of these, Dromiskin, provides the only close parallel for Bealin B 3 (Roe 1954, Pl. XII). Here there is a stag being chased by a hound and followed by a horseman, this time placed on the horizontal rather than adapted to a vertical panel.

As Françoise Henry (1965, 145) has pointed out the composition of the Bealin panel has much in common with the way in which hunting scenes are set out on the backs of Class II slabs in Pictland and this is also true of similar scenes on the Ossory monuments (see p124). The style of carving of the early Class II slabs such as Aberlemno II (Allen and Anderson 1903, III, Fig 227B) with its low, flat relief with some of the details picked out by incised lines may also be compared with Bealin. Although the actual composition is not paralleled in Pictland, hunting scenes with horsemen, hounds and stags are common. Thus scenes rendered in a similar spirit to Bealin may be pointed out on a fragment from Elgin (op.cit, III, Fig. 138), which shows a bounding stag with a lolling tongue being ravaged by a pair of hounds, though in this example they gore its breast and back. On Meigle XII (op.cit, III, Fig. 346C) there is a stag shown in profile fleeing

towards the left with a rather plump hound behind biting its left hind leg. On these two examples there are no horsemen but there are many other Pictish stones with stags being attacked by hounds and pursued by horsemen, for example Hilton of Cadbol (*op. cit.*, III, Fig. 59).

There is a second possible hunting scene situated in a more usual position on the base on Clonmacnoise IV C 7. It is badly weathered but the fragmentary horses suggest a hunting scene on a much grander scale than Bealin B 3 perhaps comparable with Kilree C 3 and 4 or Killamery A 4 (see p152) or even some of the more complex Pictish representations (see p124).

On Banagher A 2 is a stag placed in a panel by itself. It seems to be drawn from the same model as the Bealin example, the positioning of the legs, the two branched antlers and the lolling tongue being the most characteristic features. However, perhaps owing to lack of space, there is no hound in the composition. Instead the stag's right foreleg is shown caught in a rectangular frame which Patrick Gillespie (1918-19, 165-7) has plausibly suggested is a deer trap¹⁶ and this would fulfil a similar function to the ravening hound. The religious and other possible meanings of both stags and hunting scenes are discussed in detail elsewhere (see p125). Suffice it here to draw attention to the wording of Psalm 90 verse 3 which is interesting and could be directly relevant to the Banagher carving since the Psalmist pleads to be freed from the 'snare' (laqueo) of the huntsman.

The stag by itself but without the trap is found elsewhere in Irish sculpture on Gallen Priory I A 2 and Tybroughney B 1 (see pp266,160) and the cross at Moone (Henry 1965, Pl. 68).

Since the stag on Banagher A 2 is in a panel by itself and is separated from the horseman who shares the panel above, A 1, with a lion it is unclear whether the two motives are related. It is tempting to see the huntsman armed with a spear on Bealin B 3 transposed into the ecclesiastic armed with a crozier here represented thereby adding to the suggestion of Christian symbolism but this is not clear. However, this jaunty little figure finds its closest comparisons with inter-textural illustrations on f89R and f255V in the Book of Kells (Henry 1974, Pl. 121). Mounted ecclesiastics, though not closely comparable with Banagher, are also found in Pictland and may be exemplified by Dunfallandy (Allen and Anderson 1903, III, Fig. 305B). The elegant prancing horses on Ahenny I D 9 (see p119) are also similar to those on Bealin and Banagher. The horseman on Clonmacnoise III A 1 is almost identical to Banagher A 1 except that he is

without a crozier.

The procession of quadrupeds on Clonmacnoise IV A 7 may be identified as horses in the light of their close comparison with less weathered processions of horses on Lorrha I A 2, B 2, C 2 and D 2 and Kilkieran II C 5 and 6 (see p124).

b) Scriptural Iconography

Scenes from the Bible are not common in this group. In fact they are only found on Clonmacnoise IV, again placing it slightly apart from the rest. The scenes are on a small scale, in low relief, and are not prominently placed. They are definitely subordinate to the abstract ornament. The scenes depicted are the Crucifixion on A 2 and the Fall on B 12.

The Crucifixion The representation of the Crucifixion on crosses where abstract ornament is in the majority is rare, the only other example being Killamery A 10 (see p146). Amongst the 'Scripture' crosses it is customary to place the Crucifixion on the crosshead of the west face (see p 210). However, on both Clonmacnoise IV and Killamery it is placed at the top of the shaft on the west face and not on the crosshead. This is also true of Kells South (Roe 1966, Pl. IV). In all three instances, the placing of the Crucifixion in this position would seem to indicate that the crosses belong to a period before it was customary to place it on the crosshead. In Anglo-Saxon England Crucifixions are equally rare amongst the early sculpture; nor are they placed on the crosshead (Coatsworth 1979, 200-1).

The Crucifixions on Clonmacnoise IV and Kells South are closely comparable suggesting a common model. However, the Kells version is more competently carved and shows a better grasp of the potential of relief. In contrast the Clonmacnoise Crucifixion is in very low relief and the sculptor seems to have had some difficulty in fitting the various elements into a rectangular panel. The main elements of the composition are the same on both crosses. Christ is shown face on and erect. The head is large in comparison with the body; He has short hair and is beardless. He is clad in a knee length tunic with conspicuous vertical drapery folds in the skirt. The Kells version also has drapery folds over the upper half of the body. The length of the arms is determined by the width of the shaft and traces of the cross can be seen behind. On Kells the feet point downwards,

whereas at Clonmacnoise they are turned to either side. Stephaton, the sponge bearer, and Longinus, the spear bearer, placed on either side of Christ, are characteristic of insular representations (see p212). In both cases Stephaton, on Christ's left, is shown offering Christ a cup rather than a sponge which is a specifically insular feature (Gougaud 1920, 136). On Kells Longinus is depicted with his head held back so the stream of Blood may fall in his eyes¹⁷ presumably indicating the miracle whereby his sight was restored (Roe 1966, 19; Schiller 1972, 102). At Clonmacnoise both figures are kneeling with their heads tipped back.

On Kells South there is a further pair of figures placed either side of Christ's head, that on the left facing Him, that on the right turned away. On Clonmacnoise IV there are two similar figures but they are placed the other way round. In her discussion of the possible attributes of the Kells figures, Helen Roe has suggested (1966, 19-22; Henry 1967, 162) they represent Sol and Luna, the latter turning her head away thus conforming to the tradition that at the Crucifixion the Moon turned back her course lest she saw the Death of the Son of God. This is an interesting hypothesis but unfortunately it cannot be proved because the Kells figures are not sufficiently well preserved to make their identification definite and their Clonmacnoise counterparts have no attributes suggesting the sculptor may not have completely understood his model. However, if Helen Roe is correct, this could have an important bearing on the dating of the two pieces. Sol and Luna as symbols frequently accompany the Crucifixion from as early as c 600 and may be exemplified by an ampulla from Monza (Hauteceur 1921, 15). However the Sun and Moon personified in this position is extremely unusual at an early date, a rare example being another of the Monza ampullae (Schiller 1972, Fig. 324). It is a characteristically Carolingian feature (op cit, 109, Fig. 362) and it is not until the mid ninth century that the figures turn away or express their grief by covering their faces. It therefore seems possible that the Crucifixion on Clonmacnoise IV, Killamery A 10 and Kells South may be early examples demonstrating the increasing importance attached to this scene on the Carolingian Continent during the ninth century (see p217).

However they may also be compared with other probably earlier depictions in insular metalwork, manuscripts and possibly sculpture. The Athlone Crucifixion plaque, usually attributed to the mid eighth century (Raftery, J. 1941, 106; Henry 1965, Pl. 46) has much in common with Clonmacnoise IV except that Longinus and Stephaton are standing and the figures on either side of Christ's head may be angels or seraphim. Illustrations in

manuscripts demonstrate the wide variety of models available in Early Christian Britain. These may be exemplified by St. Gall MS 61 (op cit, 196-8; Masai 1947, Pl. XXI.2) and Durham A.II.17 (Nordenfalk 1977, Pl.14). In sculpture Françoise Henry (1965, 128) has pointed out possibly early Crucifixion types at Carndonagh, Iniskea North and Caher Island (op cit, Figs. 16, 14a, Pl. IV; Thomas 1971, Fig. 61) although these may be considerably later (see p25). In Northumbria there are two early examples from Hexham and another from St. Andrew Aukland (Coatsworth 1974; 1979, 116 ff).

In nearly all these examples Christ is shown dressed in a knee length tunic or an ankle length robe with or without sleeves. Ultimately these variations would all seem to be derived from the sleeveless colobium, the earliest surviving example of which may be seen in the Mesopotamian Rabula Gospels dated to 586 (Schiller 1972, 91-2, Fig. 327). An early example of a sleeved robe may be seen on a sixth or seventh century silver plate from Syria (op cit, Fig. 322).

The Fall The carving on Clonmacnoise IV B 12 is fragmentary but the Fall may be securely identified on the left as two figures, one placed either side of a tree, are quite clear. However, no detail survives so it is impossible to tell which type (see p181) was originally depicted. It seems possible to suggest that the right hand side of the panel may once have shown Cain and Abel. These scenes are frequently depicted together on other Irish crosses (see p230).

Conclusions These sculptural scenes, though rather insignificant, are undoubtedly a foretaste of the complex iconography of the 'Scripture' crosses. A possible parallel for this development may be sought in manuscript illumination, where occasional iconographical plates were introduced at a relatively early date, but it was not until the Book of Kells that a number of episodes are illustrated and Françoise Henry (1974, 212) has suggested that one of the blank pages in that manuscript may have been intended to show a Crucifixion scene.

6) The Bealin Inscription

H.S. Crawford (1927, 2-4) (Fig. 19) was the first to comment on the existence of an inscription on Bealin A 4 and it has since been studied in detail by Françoise Henry (1930b). She interpreted the meaning of the inscription as:-

ORO IT
αΡ ΤΥ α
ΤΗΤΑΚ
λαζδεν
ναττιν
χρροζα

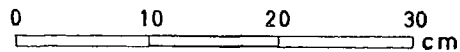

Fig 19

BEALIN A4

(After Macalister)

'Pray for Tuathgall who caused this cross to be made'

and she has gone on to link the name 'Tuathgall' with an abbot of Clonmacnoise who died in 811.¹⁸ This led her to believe that the cross was erected between 798 (A.U.), when the obit of the previous abbot is recorded and 811 (Henry 1965, 143-4). Her argument was backed up by a study of the letter forms (1930b, 111-113). If her supposition is correct this provides one of the very few fixed points in the early period of Hiberno-Saxon art with all the potential implications for the dating of stylistically related objects.

This inscription has been re-examined by Kenneth Jackson (letter, April 1978) who, although he disagrees with details of Françoise Henry's argument, is prepared to accept the possibility of the broad outline of her hypothesis. Firstly, Françoise Henry's reading of the inscription as:-

'OROI^T AR TUATHGALL LAS DERNATH IN CHROSSA'

is not entirely correct. The correct version is given by Macalister (1949, II, No. 871) (Fig. 19) who records:-

'OROI^T AR TUATHGAIL LAS DERNATH IN CHROSSA'

'Tuathgail' is the correct reading as it is the dative of Tuathgal dependent on the proposition 'ar'. Secondly, Professor Jackson is of the opinion that paleographically the inscription is suggestive of the eighth century rather than the ninth, though the early ninth century is 'not at all impossible'.¹⁹

It is interesting to note that this inscription is carved in relief. The only other known inscriptions in relief are Killamery A 13 (see p 153) and an inscription from Tarbat in Ross (Allen and Anderson 1903, III, 94-5, Fig. 96). Inscriptions on the 'Scripture' crosses are incised (see p246).

Professor Jackson sees the name of Tuathgal as being rare, although not, as Françoise Henry (1930b, 113) has suggested, unique. Padraig Lionard (1960-1, 160, Fig. 19.7) has identified a grave-slab from Clonmacnoise bearing the inscription 'TUATHGAL' using similar letter forms to Bealin with the same Abbot Tuathgal. Again this is impossible to prove.

Therefore, although the attribution of the inscription on Bealin A 4 to Abbot Tuathgal of Clonmacnoise who died in 811 can never be satisfactorily proved, the possibility that Françoise Henry's identification is correct should be taken into account and may perhaps be used in conjunction with the art historical evidence.

7) The Dating of the Monuments

As has been shown above, it is not possible to prove that the inscription on Bealin A 4 really relates to Abbot Tuathgal of Clonmacnoise

who died in 811 and therefore one is forced to consider the art historical evidence as the only other way of attempting to date these monuments.

The most important comparisons may be made with sculpture in Scotland. These similarities were first noted by Romilly Allen (1896-7, 309) and have since been remarked upon by Robert Stevenson (1956, 91-3) and Françoise Henry (1965, 145). Firstly, parallels may be drawn between the Clonmacnoise group and the early Class II slabs of Southern Pictland.²⁰ This group has many factors in common with the Clonmacnoise monuments which may best be illustrated by comparing the layout and ornamental repertoire of Aberlemno II (Allen and Anderson 1903, III, Figs. 227A and B) with Bealin. The low relief, the shape of the crosshead with its central roundel, the large scale motives, some of the interlace types, the preference for decorating the length of the shaft with a single pattern, the procession of birds with spiralled, interlaced bodies and the use of figural scenes which could be secular or have religious symbolism are all common to both monuments. Secondly, similarities have also been noted between Clonmacnoise IV and the high relief 'Boss Style' of both Pictland and Dalriada.

Isobel Henderson (1967, 132-3) has suggested that the Class II Pictish monuments developed during the early eighth century immediately following the Northumbrian/Pictish rapprochement of c.710. However, Robert Stevenson (1955, 112-6), although he would agree with the Northumbrian stimulus, has suggested a slightly later date of development during the second half of the eighth century and recently further credence has been lent to this because of Rosemary Cramp's views (1978, 6-7) on the beginning of freestanding crosses in Northumbria which she would date c 740 (see p 33). Robert Stevenson (1955, 117-20) has gone on to suggest the gradual development of relief carving culminating in monuments like Nigg, the St Andrew's Sarcophagus and the Iona crosses which are likely to date c 800, as Iona was evacuated in 806, and it is unlikely that the crosses would have been executed after this. It seems very probable that influences from Pictland could have been passed on to Ireland possibly by way of Iona (Stevenson 1956, 84 ff) although one should not ignore the possibility of reciprocation. It also seems likely that the increased emphasis on relief which may be seen between the early Class II Pictish slabs and Scottish 'Boss Style' may be paralleled in Ireland in the difference between Bealin and Clonmacnoise IV.

Comparisons between the Clonmacnoise monuments and other Irish sculpture are more difficult to make. In particular Bealin, Banagher and Clonmacnoise

I, II and III have their own distinctive ornamental repertoire and style of carving which is not really paralleled elsewhere although certain motives such as interlace and spiral patterns may be compared with Kinnitty I and Tihilly (see pp173,178) and the use of anthropomorphic ornament may also be compared with Kells South. In contrast Clonmacnoise IV, although it shares many characteristics with the other Clonmacnoise monuments, also has many aspects in common with other groups of Irish sculpture. Firstly, the form of the monument, which distinctly shows the influence of metalworking techniques, and the high relief may be closely compared with the Ossory crosses (see p 96). Secondly, some motives on Clonmacnoise IV, particularly the inhabited vine - scroll and the Crucifixion, may be directly compared with Kells South, a cross which is most unlikely to have been carved before 806, when the Ionan community moved to Kells (Brown, T.J. 1972, 241), and could, if Helen Roe's analysis of the Crucifixion iconography is correct (see p 87), date to the mid ninth century or later.

Important comparisons may also be drawn between the Clonmacnoise monuments and elements in the repertoire and style of Hiberno-Saxon manuscript illumination and the Book of Kells²¹ in particular. Françoise Henry (1965, 144-5) has noted the similarity between the little figures dotted round the text and the figures on Bealin and Banagher but the parallels go much deeper. They can be seen in certain aspects of the interlace repertoire and its execution, in the zoomorphic ornament with its processions of creatures and dragonesque and leonine beasts and in the anthropomorphic designs. The use of inhabited vine-scroll and Scriptural iconography may be compared with Clonmacnoise IV. Therefore, it seems certain that the sculptors of the Clonmacnoise monuments were well acquainted with and influenced by the ornamental repertoire and style of luxury Hiberno-Saxon manuscripts like the Book of Kells, whenever and wherever it may have been illuminated.

Various similarities have also been suggested between the Clonmacnoise monuments and pieces of Hiberno-Saxon Vernacular Style metalwork. A large number of comparisons have been made with a group of engraved objects but certain parallels may also be drawn with objects cast in high plastic relief (see Appendix 2).

The form of the Clonmacnoise monuments, the repertoire of ornament and the comparisons that have been made do suggest some progression within the group. Bealin, Banagher and Clonmacnoise I, II and III have a very similar repertoire of ornament although the actual monument types range from a freestanding

cross through large and small shafts. The similarities that have been noted between them and the early Class II Pictish slabs would suggest a date during the second half of the eighth century. The Bealin inscription would lead one to believe a date at the end of the eighth or the beginning of the ninth century but this could be misleading. This sculpture is heavily influenced by manuscript illumination and to a lesser extent by metalworking techniques.

Clonmacnoise IV, although it has many features in common with the other Clonmacnoise monuments, would seem to be a later development. It seems to have been carved at a time when Clonmacnoise was losing the distinctive style associated with the rest of the group and was now also influenced by sculptural traditions elsewhere in Ireland and by Kells South and the Ossory crosses in particular. The comparisons which have been made between Clonmacnoise IV and Scottish 'Boss Style' suggest a later date, perhaps during the early ninth century. However, if the identification of Sol and Luna on the Kells South and Clonmacnoise Crucifixions is correct, Clonmacnoise IV could be as late as mid ninth century although the first recorded Viking raid on Clonmacnoise is 834 (A.U.) and the more extensive onslaught during the 840's may have tended to preclude major artistic projects (see p250).

Ch. IV. FOONOTES

1. This group does not include Clonmacnoise V and VI as their ornament is very different (see Chs. X, XI (1)).
2. It is thought that Bealin could originally have come from Clonmacnoise although it is now situated about 15 miles to the North East. Françoise Henry (1965, 143 note 1) has suggested that it is marked on a seventeenth century map of the monastery (Ware 1658, 304). In the revised version of this map (Ware and Harris 1739, II, 46) four crosses are shown. Clonmacnoise IV and V are situated as they are today and a third monument is in the approximate position of Clonmacnoise I. However, a fourth cross is also indicated approximately 70 feet to the South East of Temple Rí. This could be Bealin but obviously it cannot be proved.
3. It should be noted that since the completion of the text Carola Hicks' article 'A Clonmacnoise workshop in Stone' in JRSAI 1980, Vol. 110, 5-35 has been published.
4. It is interesting to note that with both St. Oran's and St John's crosses the shaft is carved from a single piece of stone with a tenon at the top and the crosshead consists of a number of pieces joined onto this.

5. In this context the fragmentary freestanding ringless cross from Edzell, Angus, which may be compared with Aberlemno II should also be noted (Stevenson 1958-9, 42).
6. The Derrynavlan hoard, discovered in March 1980, is undoubtedly an extremely important find of Vernacular Style metalwork. It had been hoped to give more detailed comparisons between the sculpture and this hoard which is a major find in the region covered by this thesis. Unfortunately it has proved impossible to obtain photographs of sufficient detail to make such comparisons. Where possible comparisons have been made using available published photographs (Ó Riordáin, B. 1980a; 1980b; Ryan, M. 1980) and from notes taken during a visit to the National Museum, Dublin in March 1980.
7. This is abundantly illustrated in the seventh century Life of St Brigid by Cogitosus where millstones are conveyed down a hill by the miraculous power of the Saint. There is also a roughed-out shaft still lying at the quarry site near Bewcastle (Brown, G.B. 1921, 315-6).
8. It has not been possible to have the stone petrologically examined. In the case of Clonmacnoise this could prove informative.
9. Stevenson (1955, 122) dates Meigle IV as probably earlier than Meigle II, one of the major examples of Late 'Boss Style'.
10. In Henry's illustration (1933, Fig. 45) the heads of the men on the Old Kilcullen panel are mistakenly shown face on.
11. In its use of vine-scroll and other vegetal ornament the Book of Kells stands slightly apart from other Hiberno-Saxon manuscripts.
12. The date and provenance of the bowl are controversial. Bruce-Mitford (1960b) and Bakka (1963, 9) both see it as early, contemporary with the Ruthwell and Bewcastle crosses. Kendrick (1938, 150, Pl. 60) prefers to see it as later and contemporary with Croft.
13. Robert Stevenson (Pers.Comm. Feb. 1979) has also suggested the possible parallel transformation of vine-scroll into interlace roundels on some of the Pictish early Class II slabs, for example Meigle I (Allen and Anderson 1903, III, Fig. 310A) which has a kind of interlace root at the bottom.
14. Cecil Curle (1939-40, 98) has suggested that 'Boss Style' may have evolved in Iona and then spread eastwards but Robert Stevenson's (1955, 119; 1956, 90) view that the style may have begun in Fife and Angus passing to Iona via Ross and Cromarty seems more likely. See also (Henderson 1967, 134). Isobel Henderson has also suggested (Pers. Comm. April 1977) that the ultimate origins of this style could lie in Northumbria.
15. It is also interesting to note that on the Hunterston Brooch, Robert Stevenson (1974; 39-40, Pl. IX) has suggested the possible Christian significance of the menagerie of animals which all face towards the cross shape at the point where the penannular terminals join.
16. Several examples of these are currently displayed in the National Museum, Dublin.

17. The story of Longinus' blindness is apocryphal but seems to appear in Ireland at an early date. It is first found in the writings of Blathmac (lines 217-32) whose floruit may be regarded as mid eighth century (Dumville 1973, 305; Carney 1964). This text provides the earliest literary reference to this story in the west.
18. AU 810 (recte 811) 'Tuathgal, a most wise abbot of Cluain died' ('Tuathgal, abbas sruithe Cluaná mortuus est').
19. Professor Jackson would, however, disagree with the emphasis Françoise Henry (1930b, 113) places on the reversed 'S' and the form of 'DERNATH' in the inscription, and believes them to be chronologically insignificant.
20. An 'early group of Eastern cross-slabs' was first identified by Cecil Curle (1939-40, 82) and at the same time she noticed that they seemed to show 'strong Irish influence'. The definition of this group was refined by Robert Stevenson (1955, 112-6). The group consists of Aberlemno II, Eassie, Glamis I and II, Meigle I, Rossie and St. Vigean VII.
21. A great amount of ink has been spilt in discussing the origin and date of the Book of Kells, problems which are unlikely to ever be solved satisfactorily. The best recent considerations of this manuscript are provided by Julian Brown (1972) and Françoise Henry (1974).

Chapter V. THE OSSORY GROUP

This group of monuments clusters on the two sites of Ahenny and Kilkieran situated about a mile apart in the Slievanamon Hills to the north of the River Suir (Map II). In the Early Medieval Period this area was part of the ancient Kingdom of Ossory which acted as a buffer state between the Laigin to the North and the Eoghanacht to the West (MacNiocaill 1972, 85) and by the end of the eighth century it had become a powerful border kingdom which controlled all routes between Leinster and Munster (Ó Corraín 1972, 6). St Ciarán of Saighir was the patron saint of Ossory, though the importance of his monastery at Seir Kieran gradually faded in favour of Ághadoe in the latter part of the period (Carrigan 1905, I, vii, 1-2; Kenney 1929, 316, 318, 394).

Nothing is known about the monasteries which must once have flourished at Ahenny and Kilkieran; they cannot even be identified as names in the annals. This anonymity led Françoise Henry (1965, 138) to suggest a link with the important monastic centre of Lismore to the South West, which has no surviving diagnostic sculpture, and, by an even more devious route, with the monastery of Ferns in Wexford (op cit, 141; Curle 1939-40, 103-4). Liam De Paor (Pers. Comm. Sept. 1977) has also suggested that the area may have been connected with the Columban Church and Iona. These postulated links are at present untenable due to lack of sound evidence. The Lismore connection seems particularly unlikely as its sphere of influence was concentrated on South Munster. However, these monasteries may rather have looked towards Seir Kieran, the foundation of the local saint. At this site there are still extensive archaeological remains including impressive remains of the vallum monasterii (Hughes and Hamlin 1977, 124). Amongst several pieces of sculpture is a cross base which may be included in this group.

There are further outliers which also have significant links with the Slievanamon crosses at Lorrha. This monastery, situated on the borders of Munster and Connaught (Gleeson, J. 1915, 230-3), was founded by St. Rúadán and was amongst the most important monasteries of Munster (Kenney 1929, 391-2).

A base fragment, Mona Incha I, will also be included in this group. Mona Incha, the dísert of the monastery at Roscrea, was an important element in the Reform Movement in the late eighth century (Kenney 1929, 469).

Therefore the Ossory group consists of four complete crosses: Ahenny I and II and Kilkieran II and III. In addition there is a fragmentary monument, Kilkieran I, two cross bases with shaft fragments, Lorrha I and II, and cross bases from Seir Kieran and Mona Incha (I).

1) The Form and Layout of the Monuments

Amongst this group the form of the cross is extremely important. The sculptor does not merely display his repertoire upon a monumental cross, but rather the layout of the ornament is completely dictated by that form and is designed to fulfil particular functions in relation to it.

The forms of the complete surviving crosses are closely comparable. They are characterised by a very large crosshead in comparison with the length of the shaft, which often has a butt, and the tendency towards a very large base.

In each case the crosshead is Type II (Fig.39). The upper crossarm is elongated and bosses are placed at the centre of the crosshead, on the crossarms and at the top of the shaft. This type does not have other parallels in Ireland but the position of the wheel may be compared with some of the more developed Pictish Class II monuments (Stevenson 1955, 120-3). The best parallel is provided by Aberlemno III (Allen and Anderson 1903, III, Fig. 228A), where the wide wheel arcs and the use of bosses is very similar to the Ossory monuments. Isobel Henderson (1978, 53) has suggested that this Pictish crosshead form may have developed under Irish influence, and this is possible, but it is also interesting to note (see p 36) that in Pictish sculpture the wheel arcs begin as thin cusps on Aberlemno II, for example, (Allen and Anderson 1903, III, Fig. 227A), possibly passing onto freestanding crosses at Iona (Stevenson 1956, 89) before reaching their maximum development on the later Class II and III monuments exemplified by Aberlemno III.

The conical capstones placed on the top of the surviving crossheads of the Ossory monuments have always been problematical. The caps, which had been found nearby, were placed on the crossheads at Kilkieran and 'restored to their proper place' at Ahenny during the nineteenth century (O'Neill 1857, II, Pl. XXVI; Carrigan 1905, IV, 243)¹ and, since none can be proved without doubt to have had caps before this, much discussion

has resulted as to whether the caps are original. Henry Crawford (1909c, 256) was inclined to believe they were genuine since they fitted and the plaitwork on the cap of Ahenny I was in keeping with the rest of the ornament but Helen Roe (1962, 13), disagreeing with both these points is more doubtful. The question would probably be satisfactorily answered if the capstones were removed to see if there was a tenon protruding from the upper crossarm to support the capstone as at Kilree (ibid) but in the meantime their originality seems the more promising hypothesis for a number of reasons. Firstly, there are no horizontal perimeter mouldings along the top of the upper crossarm on the narrow faces of the crosses. This suggests the use of a capstone since otherwise the top crossarms would have appeared unfinished. Secondly, the proportions of the monuments with their large bases would have looked unbalanced without a cap, and finally the adoption of the capstone is commonplace amongst the Irish monuments (see p 37); it is merely the conical form which is unique to this group.

The proportions of the surviving shafts are approximately similar. A characteristic stylistic detail is the division of the narrow faces of the shaft vertically into three panels. This may be seen on Ahenny I, Ahenny II and Kilkieran II and is repeated elsewhere at Kilree and Killamery (see p 11). The practice of dividing the wheelarcs into two panels is also characteristic of Ahenny I to II and Kilkieran II although it is also found on Clonmacnoise IV.

The bases in this group are shaped like a truncated pyramid. On Ahenny I there are two steps, the upper being very much shallower than the lower, and the butt acting as a further gradine before the commencement of the shaft. On Kilkieran II there are three steps and on Seir Kieran and Lorrha I the base is of even more monumental proportions, the latter leaving a sort of plinth placed on the top of the utmost step. The shape of the base of Clonmacnoise IV is similar (see p 49). The bases of Ahenny II, Kilkieran III and Mona Incha I are much smaller, having only one step.

The Mouldings The perimeter rope mouldings carved in high relief are a characteristic of this group which immediately catches the eye. As Françoise Henry recognised (1965, 140) these are clearly derivative of metalwork bindings such as those on the Copenhagen Shrine (Fig. 22). There is an early example on the perimeters of the mounts on the hanging bowl from Sutton Hoo (Bruce-Mitford 1972, Pl. 9) and cabled hoops are also common on penannular brooches. One of the most complex examples of this is found on a brooch from Ballinderry II which Kilbride-Jones (1937, 443)

dates 750-800. Similar bindings are also found on the Ardagh Chalice and on such objects as the Tara Brooch delicate filigree cables are frequently used to frame panels of ornament (Henry 1965, Pls. 39-41).

The metalwork derivation of the perimeter mouldings is most clear on Ahenny I and II. On Kilkieran II they seem much heavier and therefore lose much of their metallic quality. Perimeter rope mouldings are also found on Killamery and Clonmacnoise IV (see pp134, 49) where they are decorated with a herringbone pattern.

The use of perimeter rope mouldings in high relief results in the corresponding recession of the ornamental areas on the shafts and cross-heads. The recession is less on the broad than on the narrow faces and on Lorrha I and II only the narrow faces are recessed. The use of recessed panels but with less emphasis on the mouldings is a feature of Pictish 'Boss Style' best exemplified by Nigg and is continued on the developed Class II slab, Rosemarkie I (Allen and Anderson 1903, III, Figs. 72, 60 and 60A). The practice of using frames decorated with tight meshes of interlace which is also found on Rosemarkie I and the St. Andrews Shrine (op cit, Fig. 365) may be distinguished on the base of Ahenny II where there are traces of a plaitwork mesh on Face D. Helen Roe (1962, Fig. 3) has suggested that the crosses on the mouldings which project into the sculptural field on this cross may be derived from the end panels of Christian sarcophagi which may be divided vertically in a similar fashion as for example on a possible sarcophagus fragment from Breedon in Mercia (Cramp 1977, Fig. 57a). This is not impossible but it may be merely a further example (see p 8) of the constant use of the cross symbol as a whole.

Bosses The bosses placed at the centre of the crosshead, at the ends of the crossarms and the top of the shaft are a characteristic feature of the Ossory crosses appearing on Ahenny I and II and Kilkieran II. On Kilkieran III there is a single boss in the centre of the crosshead. On Ahenny I there are both small domed bosses, decorated with interlace patterns, and 'nailhead' bosses. The former may be compared with bosses in similar positions on Bealin A 1, Clonmacnoise IV A 1 and C 1 and Kilree Face A (see pp47, 134) but the latter undoubtedly owe their origins to metalwork and it is their resemblance to 'les boutons couvre - clous émaillés' (Henry 1933, 50) which has caused them to be termed 'nailhead' bosses. The central 'nailhead' boss on A 1, with its raised cruciform centre composed of possibly zoomorphic heads is particularly elaborate. On Ahenny II the bosses

are less complex, retaining much of their metallic quality, but on Kilkieran II they are much heavier and more bulbous and their metallic origins are no longer clear.

The development of such bosses in both sculpture and metalwork is an important aid in the placing of the Ossory crosses in the wider context of Hiberno-Saxon art. Their ultimate origin may perhaps be traced back to Northumbrian metalwork (Henderson, pers. comm. April 1977) where domed bosses are found on the base of the Ormside bowl (Kendrick 1938, Pl. 60). They are also taken up by Hiberno-Saxon metalworkers attaining their most complex and sophisticated forms on the Ardagh Chalice, the St. Germain plaques and many of the more developed penannular brooches. It is with these, and the Tara brooch in particular (Henry 1965; Pls. 38, 40, 41) with its wide variety of 'nailhead' bosses, that the Ahenny I and II bosses have most in common.

In Pictish sculpture Cecil Curle (1939-40, 97 ff) and Robert Stevenson (1955, 117 ff) have traced the parallel development of the high relief 'Boss Style' culminating in Aberlemno III, the St. Andrew's Shrine, Nigg and fragments from Tarbat (Allen and Anderson 1903, III, Figs. 228A, 365, 72, 91, 92) amongst others. However, it is the Dalriadic 'Boss Style' crosses centred on Iona which provide the closest comparisons for the Ahenny bosses (Stevenson 1956, 91-2). The layout of the bosses on the crossheads of St John's, St. Martin's and Kildalton in Islay are identical (Allen and Anderson 1903, III, Figs. 399A, 397B, 410). It is possible that these three crosses show a gradual development from small 'nailhead' bosses on St John's cross, through the meshed bosses on St Martin's to the bulbous domed bosses elaborated by zoomorphic ornament on the Kildalton Cross. There could be a similar development between the bosses on Ahenny I with their clear metalwork origins and their more bulbous counterparts on Kilkieran II. 'Nailhead' bosses are also translated into two dimensions for the manuscript medium where they appear in the Book of Kells (eg f2V; Henry 1940, 148).

The Form of Kilkieran I (Fig. 20) Kilkieran I is incomplete. The nature of the surviving fragments make the original form of the monument difficult to reconstruct but a freestanding cross seems likely. Fragments a and b have been correctly re-aligned but they do not join. It seems likely that Fragment a is part of a cross arm while b and c form the shaft of the monument. Faces A and C are presumably the original broad faces although some of their width is now lost. The recessed panels on Faces B and C may

Fig 20.2 KILKIERAN I

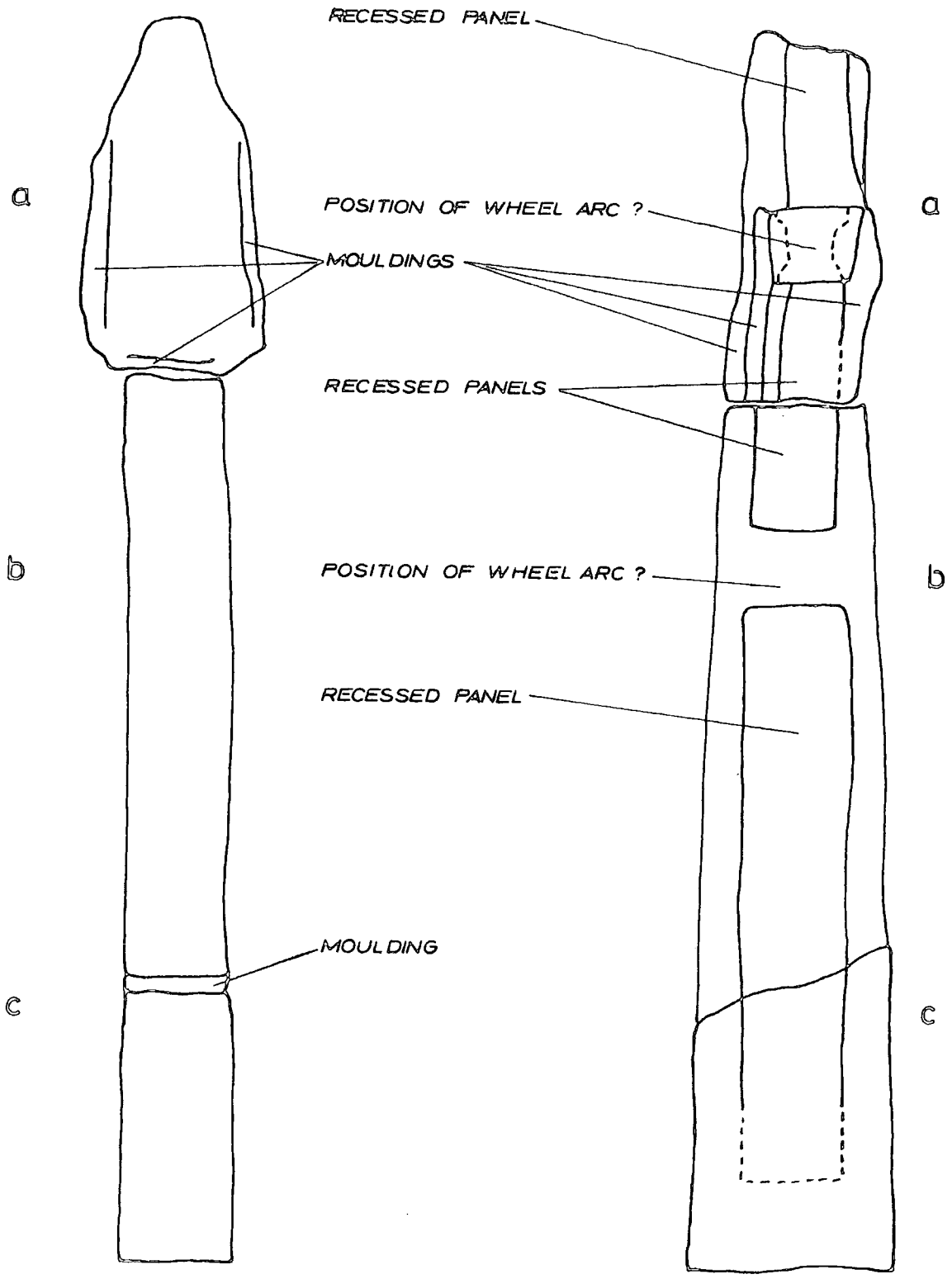

indicate large perimeter mouldings which would tie in with the rest of the group, and the protruding areas on a and b could be the stumps of wheel arcs.

2) The Ornament

Apart from Kilkieran III, which is undecorated, these crosses are dominated by abstract ornament. As Françoise Henry said 'not a square inch of the surface remains unadorned; ornaments run on the stone, covering it like embroidery' (1965, 140). There are figural motives but these are confined to the bases of the monuments.

a) Spirals

Spirals are not the most prolific ornament amongst the Ossory crosses but the manner in which they are executed picks them out as one of the distinctive features of the group well illustrating the important influence exerted by both the techniques and the ornamental repertoire of Vernacular Style metalwork. Spiral patterns are used extensively on the Ahenny crosses and Kilkieran I but on Kilkieran II and Lorrha I their role is less conspicuous. There is no surviving spiral ornament on Lorrha II, Seir Kieran or Mona Incha I.

Ahenny I The unique skill of the sculptor of this monument is amply illustrated by the accomplishment of the spiral ornament. Spiral patterns are used extensively to decorate large prominent areas on the crosshead, A 1, and shaft C 2, B 5 and D 5 and smaller, less conspicuous panels at the ends of the horizontal cross arms, B 3 and D 3 and the butt B 6, C 4 and D 6.

The sculptor's complete mastery of design is demonstrated by the complex spiral patterns which form the background decoration round the bosses on A 1. The entire crosshead has been planned on a horizontal/vertical grid of squares (Fig. 21). Two lines, one passing vertically down the centre of the cross, the other horizontally along the cross arms can be seen quite clearly. If horizontal and vertical lines are added so the centre of each spiral is constructed it will be found that a complex grid based on a 2.5 cm unit measure is attained. All the spirals have diameters which are multiples of this unit ranging from 5 cm to 12.5 cm. The diameters of the bosses also correspond to this system: for example the diameter of the central boss is approximately 20 cm at the bottom decreasing to 15 cm.

Fig 21 AHENNY I A1: CONSTRUCTION OF SPIRALS

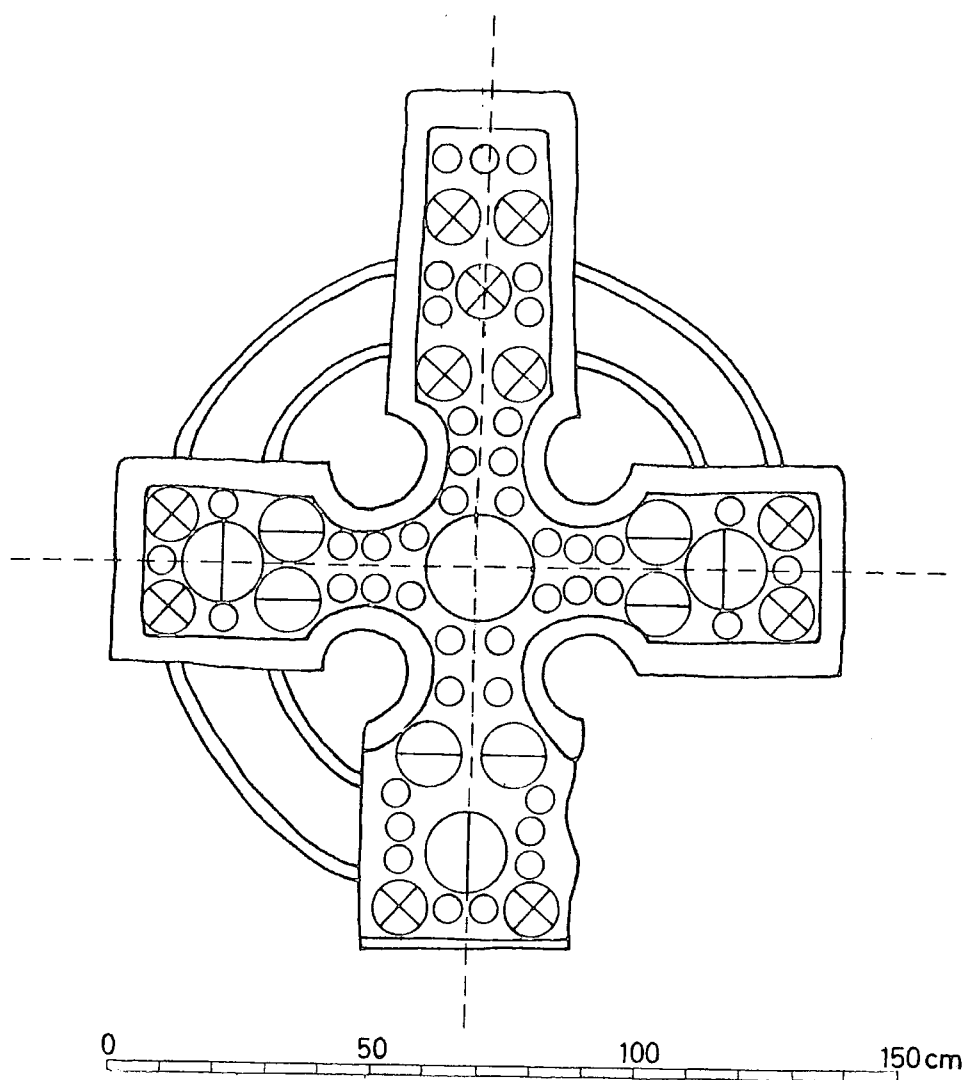

SPIRAL AND BOSS DIAMETERS



5cm



10cm



12.5cm



15cm

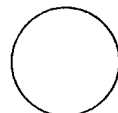

20cm

across the top. Furthermore, the crosshead dimensions, in as much as this is possible on a large monument, also conform to the grid. For example, the width of the top cross arm is 25 cm; on the left hand horizontal cross arm it has become increased to 29 cm. but to account for this there is a corresponding gap between the bottom of the carving and the perimeter moulding. The perimeter mouldings too fit into this general pattern, being approximately 5 cm. in width although they do vary somewhat in places, presumably to provide the required width for the pattern on the cross face.

This grid gave the sculptor the basis for the execution of a pattern where subtle changes in the dimensions of the spiral account for the perfection with which the uneven field of the crosshead is decorated. The pattern is simple but the variety is achieved by the constant change in the size of the spiral according to its position and by the interchange of the spiral terminals.

The whole is unified by a style of carving clearly reminiscent of chip-carved ornament in Vernacular Style metalwork. The actual spirals are conceived in a fairly flat relief but they are caught in an intricate web of deep cut triangular expansions causing the pattern to stand out. A good parallel for this kind of pattern is provided by a round flat bronze mount from a grave at Fonbekk in Norway (Petersen 1940, 16). The raised round setting in the centre of the mount is surrounded by a background carpet of interlocking 'C' scrolls with triangular expansions executed in a chip-carved technique. The triple spiral cluster terminals may be compared with the Kommes mount (op cit, 22, Fig. 12). In Pictish sculpture a further comparison may be sought with a large rectangular panel in low relief of a metallic appearance on the back of the 'Boss Style' slab at Shandwick (Allen and Anderson 1903, III, Figs. 66A, 70). Here the panel is decorated with a series of interlocking units of four 'C' scrolls of varying size, in this case radiating from a central point.

The shaft panel, C 2², is decorated with a square panel pattern of fine spirals which is particularly characteristic of the Ossory crosses. The pattern is not found very frequently elsewhere. There is an early example in an incised technique in the Mullaghmast Stone (see p21). It also appears on Clonmacnoise IV C 2, where the spirals are raised into bosses (see p 77), on Clonmacnoise V B 1 (see p241), Castledermot South, East face and in Pictland on Meigle V (Allen and Anderson 1903, III, Fig. 314A). In metalwork there are examples on the Moylough Belt Shrine (O'Kelly 1964, Pls. 21-2). There are no precise parallels for the style of carving although



spiral ornament is used in a similar way on St Vigean VII (Allen and Anderson 1903, III, Fig. 278) and the recently discovered fragment from Applecross (Unpublished) which has deeply slashed triangular expansions reminiscent of metalworking techniques. The birds' head terminals on Ahenny C 2 may be compared with those on St Vigean VII and Applecross and in Irish sculpture with Tybroughney A 1, Kilree A 1 and Clonmacnoise I D 3. The triangular 'C' scroll expansions on Ahenny I C 2 are similar to those on Clonmacnoise II A 1. (see p 76).

The central long vertical shaft panels, B 5 and D 5, are decorated with a single border of 'S' scrolls whose dimensions enlarge with the increasing width of the panel. This pattern is a frequent occurrence in metalwork borders exemplified by those on the St Germain plaques, the base of the Ardagh Chalice (Mahr 1932, Pls. 26, 52), the Prestgarden Mount (Petersen 1940, 15, Fig. 3) and the paten stand from the Derrynavlan Hoard (Ryan, M. 1980, 1).

In contrast the spiral panels on Ahenny I B 3, B 6, C 4, D 3 and D 6 are less conspicuously placed and much simpler.

Ahenny II Spiral ornament is used extensively on this monument but the repertoire is small. It is used to decorate several shaft panels on the broad faces, A 7 and 8 and C 2, spiral elements on the narrow faces of the shaft, B 5, D 5, the panels at the ends of the horizontal cross arms, B 3 and D 3, and the wheel arcs A 5 and 6.

The square panel pattern with five spirals, which is so characteristic of the Ossory monuments, is frequently used on this cross, being found on A 7 and 8, C 2, B 3 and D 3. C 2 in particular may be compared with Ahenny I C 2. However, the stylistic details of Ahenny II A 7 and 8 are rather different. These variations are achieved by constant changes in the diameters of the spirals, the use of spiral curlicues on the expansions of A 7, a detail paralleled on Tybroughney A 1 and Clonmacnoise IV C 2 (see pp165, 77), and the use of foliaceous spiral terminals. These feathery leaves are also found in metalwork. The best comparison is provided by a rectangular silver mount decorated in an openwork technique from a Norwegian grave at Vindalen (Petersen 1940, 26). Here two hair-spring spirals terminate in flowing foliage, a further spiral curlicue being tucked between the two. Other comparisons may be made with the roundels on the Copenhagen shrine and the St Germain plaques (Mahr 1932, Pls. 16, 26). In addition the spirals are not carved on a flat façade but hollowed out. This, again, is

found on Tybroughney A 1 but is apparently unparalleled on surviving metalwork. As Françoise Henry has commented the sculptors of these crosses were fascinated by the complexities of perspective (1965, 140) and these 'hollowed bosses' provide a further example of this.

The five spiral patterns on Ahenny II B 3 and D 3 may be compared with those in a similar position on Ahenny I B 3 and D 3. The long, central shaft panels, B 5 and D 5, are decorated with several units of a somewhat crude pattern of interlocking 'C' scrolls similar to Ahenny I B 6 and D 6.

Kilkieran II There is much less spiral ornament on this cross. It is confined to two shaft panels, A 2 and C 2, and a single panel on the base. The influence of metalworking techniques, especially chip-carving, is far less apparent.

The shaft panels A 2 and C 2 are placed in similar positions to those on Ahenny I and II. Both panels are badly weathered but they may consist of two single borders of 'S' scrolls, a common way of filling wide borders on metal objects exemplified by the border pattern on Christ's robe on the Athlone Crucifixion plaque (Mahr 1932, Pl. 28). The spirals seem to have been executed in low, rather flat relief, the mesh of strands down the centre of A 2 being the only surviving stylistic detail reminiscent of metalworking techniques.

A 8 is a further example of the square panel pattern with five spirals. The simple style of execution may be compared with Ahenny I B 3 and D 3 and Ahenny II B 3 and D 3.

Lorrha I There is only one surviving spiral pattern on this monument, A 4, placed in an identical position on the base to Kilkieran II A 8. The style of carving is rather crude and there is no indication of the influence of metalworking techniques. The pattern, which is badly weathered, is now difficult to reconstruct, but it may fall into the same category as roundels containing spiral patterns, sometimes set in a square frame found on Kells South (Roe 1966, Pl. II), Tihilly C 1, Kinnitty I C 1 (see p137) and Aberlemno II (Allen and Anderson 1903, III, Fig. 227A).

Kilkieran I The spiral ornament on this monument is rather different from that already discussed. The spiral pattern on Face C of fragments a and b, a double border pattern of 'C' scrolls, may be compared with Ahenny I A 1 but the style of carving is different since there are no indications of the influence of chip-carving. The style adopted is much more delicate. The simple curves and low relief of fragment a recall stamped metalwork spirals such as those on the Moylough Belt Shrine (O'Kelly 1964, Pl. 18) while the

ornament on fragment b may be compared with 'engraved' Vernacular Style metalwork. It is interesting to note that at the bottom of this panel is a single spiral which breaks the symmetry of the pattern. Such asymmetry, though common in La Tène Celtic art (Fox 1958, 141), is rare in Early Christian spiral patterns (see p 10). The Vinjum object is decorated with a band of engraved 'C' scrolls which also have a tendency to be asymmetrical (Mahr 1932, Pl. 30).

Conclusions Therefore, although there is quite a lot of spiral ornament on these crosses, the repertoire of patterns is surprisingly small. The ornament appears at its most complex on Ahenny I where three different types of spiral pattern are used: a square panel pattern of five spirals, a hallmark of the group, a double border of 'C' scrolls and single border patterns of 'S' and 'C' scrolls. The rest of the group have similar patterns but they are executed more simply and less well.

It is unclear whether common constructional grids were in use amongst these monuments. The sculptor of Ahenny I A 1 undoubtedly used a complex constructional system based on multiples of 2.5 cm and it is possible that a similar grid was also used on Ahenny II A 8. However, no other measurements seem very consistent so the pattern may merely have been adapted to the size of the panel. Some patterns, especially the smaller panels which are inconspicuously placed, have a distinctly freehand appearance: for example Ahenny I B 5 and D 5 and Kilkieran I C 1 where the diameters of the spirals and the lengths of the scrolls vary considerably from unit to unit.

As has been noted the distinctive style of carving on Ahenny I and II is heavily influenced by Vernacular Style chip-carved metalwork. Less close parallels may also be suggested in Pictland, particularly in the north, where there are several monuments which show the influence of metalworking techniques. Shandwick and Applecross have already been mentioned but the most striking parallels with metalwork may be made with a variety of small fragments from Tarbat (Allen and Anderson 1903, III, Figs. 92, 93, 95, 96) and it is this resemblance which led Cecil Curle (1939-40, 103-4) and Françoise Henry (1965, 141) to suggest the unlikely link between the monasteries of Nova Ferna at Tarbat and Ferns in Wexford.

b) Interlace

Interlace ornament is used prolifically throughout the group with the exceptions of Kilkieran I and Mona Incha I.

The repertoire of patterns is extremely simple. Almost every pattern is

made up entirely of simple plaitwork motives incorporating a varying number of strands. The patterns only rarely incorporate interlace elements A - F and knotwork designs are almost completely unknown apart from the most elementary stafford knots (E) and carrick bends (F). Since large areas are covered with a simple plaitwork mesh the immediate problem is one of repetition and monotony. This is alleviated in a variety of ways by the introduction of simple knotwork elements into the plaitwork design, the breaking and rejoining of strands to lessen the density of the plaitwork mesh and, in some cases, the constant variation in the number of strands used.

An immediate question arises as to how these patterns were constructed. The even plaitwork mesh on Ahenny I C 1 testifies to the use of constructional aids but with other monuments in the group this is much more difficult to ascertain. Many of the patterns appear uneven and the orderliness of the plaitwork mesh on some of the Kilkieran II panels breaks down completely. This suggests that much less forethought was exercised before the patterns were executed. The key to the problem seems to lie in whether a constructional grid was used and if so whether it was a square or diagonal grid. As has already been shown (see p 9) the likelihood of a square or diagonal grid is established by measuring the vertical, horizontal and diagonal distances between the crossing points of the strands. On these crosses, except for Ahenny I, the diagonal measurement between the crossing points is frequently more consistent than those on the horizontal or vertical, thereby suggesting a diagonal grid. Therefore it appears that both square and diagonal grids were used. However, in some cases the patterns are so uneven, it seems likely that no constructional grid was adopted. Perhaps the crossing points were merely worked out in advance by eye.

There are no very consistent unit measures for the interlace amongst this group although many of the interlace patterns on Ahenny I make use of a 2.5 cm square grid, the same as for the spirals on A 1 and thereby displaying an overall unity of design for the monument. It is possible that the unit measures on Ahenny II are related to this. On Kilkieran II, Lorrha I and Lorrha II there are a number of patterns using diagonal grids which have unit measures of 1.5, 3 or 4.5 cm. The interlace strands are rounded and carved in quite high relief. Usually the strand is plain, the only exceptions being on Ahenny II A 1, B 5 and C 1 where a strand with a median groove is employed.

Ahenny I

On this cross interlace fulfils a number of functions. It is used as the background ornament on the crosshead, C 1, and to decorate the bosses on A 1. Otherwise its use is confined to small panels in less conspicuous positions on the shaft, A 3, the base, A 5 and C 5, and under the wheel arc, D 4.

The background ornament on the crosshead, C 1, shows the sculptor's grasp of interlace is infinitely superior compared with the sculptors of other monuments in this group. The layout of the interlace re-iterates the care taken over the design already illustrated by the spiral patterns on A 1. The careful planning has eliminated the problem of how to fill an irregular area with an even carpet of ornament. However in some places the unit measure, 2.5 cm, and strand width become slightly stretched or decreased in order to fit the pattern into the space available. One example of this is the slightly uneven patch of interlace on the left hand horizontal cross arm at the point where it broadens out. However, the changes are so subtle that the unevenness of the pattern is barely noticeable.

At first glance the pattern appears as a continuous mesh of plaitwork strands. However, on closer inspection it will be seen that the monotony is constantly broken by the introduction of a variety of simple knotwork devices and two cut-out cruciform shapes are introduced on the top cross arm. These details illustrate the fact that the sculptor, although he favoured the use of basic plaitwork designs, was also acquainted with proper knotwork patterns.

The interlace patterns on two of the bosses on A 1 may be compared with the flat central roundel on Bealin A 1 (see p 53).

Otherwise the interlace patterns employed are very simple, seeming frequently to act as fillers. The patterns consist entirely of combinations of Simple E or F elements or small areas of plaitwork. The use of two parallel bands on the lower wheel arc, D 4, is particularly characteristic of the Ossory monuments. Here the size of the pattern is altered according to the area to be covered. A 1.25 cm unit measure is used horizontally but it is lengthened on the vertical. Thus the strands do not cross at right angles. There are also glides of 2.5 cm introduced between some of the units.

Ahenny II Interlace ornament is used extensively on this monument but, compared with Ahenny I, it is not nearly so competent or elegant. Patterns contained within rectangular areas are tackled with a fair degree of confidence but as soon as an irregular space is to be decorated the sculptor

seems to have encountered difficulties resulting in an uneven pattern. It is uncertain whether any constructional grids were used, although the distance between the diagonal crossing points is more even suggesting a diagonal grid is the most likely. This is perhaps underlined by the use of a strand with a median groove. On the diagonal a unit measurement of approximately 5cm. is frequently obtained combined with a strand width of 2.5 cm. which suggests links with Ahenny I.

The patterns used are extremely simple being almost entirely plaitwork meshes. The only knotwork used at all are Simple E and F elements and this could suggest that the sculptor's knowledge of knotwork patterns may have been severely limited.

Large areas of plaitwork are prominently placed being used as background ornament on the crosshead A 1, A 2 and C 1; it is also found on the wheel arcs, A 3, A 4 and C 1. On the narrow faces, B and D, the patterns, though used prolifically, are very scrappy being confined to short lengths of plaitwork and combinations of Simple E or F elements used as fillers. They are always subordinate to the actual form of the shaft.

On the crosshead the sculptor has immediately encountered the problem of how to decorate an irregular area with an even mesh of plaitwork strands. On A 2 the strands are somewhat uneven but, by the introduction of pairs of confronted dragonesque heads at the four points where the cross arms broaden out (see p114) the sculptor has eliminated the worst difficulty of how to convert the plaitwork pattern to the greater width of the panel. The interlace is thereby reduced to small areas of four strand plaitwork on the narrow parts of the crossarms which divide to form short lengths of two strand twist round the bosses.

On C 1 the same problem has not been solved with so much dexterity because the sculptor has attempted to cover the whole area without a break in the plaitwork mesh. The actual line of the pattern has, on the whole, been maintained, but it has a clumsy uneven appearance. The sculptor has encountered particular difficulties at the points where the crossarms broaden out. On the upper cross arm there is a bold six strand plaitwork design with large gaps between the strands and a deeply cut field. Here the vertical unit measure is double that of the horizontal, this giving the pattern the appearance of having been stretched. This elongation of patterns is a common characteristic of plaitwork patterns on monuments in this group.

Kilkieran II Interlace ornament is extremely prolific on this cross. Nearly every panel is decorated with a great number of very simple plaitwork

panels, but there are no knotwork elements included. The patterns are used in a similar way to the interlace on Ahenny I and II. They are used to decorate large areas of the crosshead, A 1 and C 1, one of the broad shaft panels C 3 and nearly the entire surface of Faces B and D. In addition there are also plaitwork panels on the bottom step of the base, A 7, A 9, B 9, B 10, C 9 and C 10. On Ahenny I and II figural panels are found in this position.

Many of the plaitwork patterns are very uneven and therefore it is very difficult to tell whether any type of constructional grid was used. However, a diagonal grid seems likely in some cases since if the diagonal distances between the crossing points are measured they are frequently found to be reasonably even. Furthermore the diagonal unit measurements are often found to be 4.5 or 3 cm. with a strand width of 1.5 cm. suggesting that distinctive unit measures could have been used.

In decorating the uneven field of the crosshead, A 1 and C 1, the sculptor has encountered the same problems as the sculptor of Ahenny II. The pattern on the upper part of the top cross arm of C 1 is relatively even with an approximate diagonal unit measure of $4 < 4.5$ cm. but as soon as the task of decorating the more irregular area in the centre of the crosshead is attempted the pattern becomes a riot of uneven strands. The sculptor seems to have concentrated his skills entirely on filling every inch of the available space rather than maintaining an even pattern. The result suggests very little forethought in the planning of the design.

He has fared better on A 1. The background plaitwork has the appearance of being fairly competent because the strands are very close together. Therefore the pattern is on a very small scale making the transition between broad and narrow passages very much easier to achieve. To aid this the strand width and the diagonal unit measure vary according to the size of the area to be covered. The transition between broad and narrow is particularly apparent on the top cross arm. Occasionally the strands are broken and rejoined, presumably to ease the monotony of the continuous plaitwork mesh. These breaks can be clearly seen in the upper part of the crosshead.

The plaitwork ornament on Faces B and D and the base is very simple indeed and the problem facing the sculptor may have been the prospect of monotonous uniformity which may be illustrated by the unbroken mesh of strands on C 3. It seems that the sculptor has attempted to break this potential monotony in a number of ways, some far more successful than others.

Firstly, as on A 1, some of the plaitwork strands have been broken and rejoined. One successful example of this is found on the central vertical panel, D 5, where cruciform shapes have been introduced into the six strand plaitwork. Other examples may be seen on A 7 and D 9.

Secondly, some panels have been broken up into different sized blocks each decorated with a plaitwork pattern made up of a different number of strands. The density of the plaitwork mesh and the width of the strands vary from block to block. There is a good example of such a pattern which has been competently executed on D 10 but on B 10 the line of the pattern has been completely lost. On the latter the sculptor seems to have been attempting to construct a plaitwork mesh with a cruciform shape in the centre but in the bottom right hand corner he seems to have tried to introduce an area of less dense plaitwork with a greater distance between the crossing points. The attempt is a complete failure although why remains inexplicable since a plaitwork mesh is relatively easy to construct. There are a number of such blunders on this monument, particularly on the base which led Helen Roe to suggest (1962, 40) that an apprentice was let loose on the base while the actual cross was the work of the master. This is completely unprovable but obviously some of the difficulties must have arisen because the ornament on the monument was not sufficiently planned in advance. B 10 gives the impression of having been altered actually in the course of execution.

Thirdly, on B 9 four and five petal marigolds have been introduced into the plaitwork pattern. This is perhaps the only motif on the monument which betrays any spark of originality since the marigold motif, though long run, is unusual on monumental sculpture, the only other Irish example being found on Killamery C 2 (see p 142). Part of the background of the five petal marigold in the bottom right hand corner has not been cut away suggesting the panel is unfinished.

A fourth way of breaking the repetitiveness of a plaitwork mesh is by the introduction of glides. A good example of these may be seen on B 8 where short lengths of plaitwork are interspersed with long glides.

Finally, there is a tendency which has already been noted on Ahenny I and II, to elongate the plaitwork pattern by lengthening the vertical distance between the crossing points so the strands do not cross at right angles. The central panel of B 5 provides an example of this since the widely spaced four strand plaitwork becomes increasingly uneven and elongated with the increasing width of the panel.

Lorrha I, Lorrha II and Seir Kieran

The plaitwork ornament on all three fragments shows close links with Kilkieran II and the patterns appear equally simple.

The bottom step of the base on Lorrha I is divided into panels in much the same way as Kilkieran II and there are traces of plaitwork on B 4, C 3 and D 3 indicating that like Kilkieran II large areas were covered with a mesh of plaitwork strands. The pattern on A 3 is much better preserved. This panel shows the characteristic trick used by the Kilkieran sculptor of breaking and rejoining the interlace strands; a horizontal line can be distinctly seen across the centre of the panel. Furthermore this pattern seems to be constructed on a similar scale to some of the Kilkieran II patterns since the diagonal unit measure is 3 cm. and the strand width is 1.5 cm.

The extant plaitwork ornament on Seir Kieran is extremely fragmentary but the way in which the bottom step of Face C is divided into panels and the traces of plaitwork on B 2, C 4 and C 5 indicate its close affinities with both Kilkieran II and Lorrha I.

On Lorrha II the base is undecorated but the plaitwork meshes on the shaft have very much the same appearance as those on Kilkieran II although the narrow faces, B and D, do not seem to be divided vertically into three panels. Like Kilkieran II also the plaitwork meshes vary in density, there is a tendency towards the elongation of the pattern and a number of patterns make use of an approximate diagonal unit measure of 4.5 cm. and a strand width of 1.5 cm. The plaitwork on C 1 demonstrates a further variation whereby the plaitwork strands may be broken and rejoined in order to break up the plaitwork mesh. Here an inset has been introduced of simple interlocking semi-circles (RA No. 766), a motif which is also found amongst the Barrow Valley crosses (see p 196).

Conclusions Therefore, while the repertoire of interlace ornament is very similar on these crosses, the standard of execution varies considerably. The sculptor of Ahenny I had a clear grasp of the constructional methods of interlace and some knowledge of the possibilities of knotwork designs. The skill of the men who carved Kilkieran II, Lorrha I and II and Seir Kieran is undoubtedly inferior.

As with the spirals the parallels for these simple plaitwork patterns, and those on Ahenny I and II in particular, are to be found on Vernacular Style metalwork, especially objects carried out in a chip-carved technique. The concept of using interlace strands to fill the background of a

given shape, in the same way that the area round the bosses on the crosshead is decorated on the Ahenny crosses, is early found on the Lullingstone hanging bowl, where an axe shaped mount with a flat central roundel is filled in with a broad two strand twist so as to block out the background completely (Haseloff 1958, 74, 80). This broad band interlace becomes adapted to manuscript illumination and also to sculpture, where it is used to decorate the entire crosshead on both faces of the Fahan Mura slab (op cit, 84, 87) (see p 25). Gradually the interlace strands become finer and in Vernacular Style metalwork this is represented in filigree, engraved and chip-carved techniques. A good example of chip-carved plaitwork, here used to decorate the background between writhing snakes and bosses, may be seen on the St Germain Plaques (Mahr 1932, Pls. 25, 26). It is interesting to note that, like many of the plaitwork patterns on the Ossory crosses, the strands of the plaitwork on these plaques are frequently broken and rejoined in order to break up the density of the interlace mesh. A further example is provided by the engraved interlace which is used as a background to the roundels on the Copenhagen shrine (op cit, Pl. 16). Here some knot-work is used since Basic C is incorporated with a two strand twist. Background plaitwork meshes are also found on many more mundane chip-carved pieces which may be exemplified by three fragments from Viking graves in Hordaland: a rectangular mount from Seim, a mount from Førde and a cruciform mount from Støle (Petersen 1940, Figs. 45, 47, 48).

Metallic border patterns have also been adapted to decorate the narrow faces of the shafts and the wheel arcs of the Ossory crosses. The practice of dividing the shaft vertically into three panels, the central one approximately double the width of the other two, is found on the St Germain plaques (Mahr 1932, Pls. 25, 26). The ornamental repertoire of short lengths of plaitwork interspersed with Simple E and F elements is also a feature of such metalwork borders and is particularly found on penannular brooches. For example, the ring of the Snåsa brooch is divided into panels of six strand plaitwork (Petersen 1940, 66) while the borders of the Bergøy brooch show a variety of plaitwork and Simple E element designs (op cit, Fig. 43a). Simple F elements are found on the border panels of the large brooch from Ardagh (Mahr 1932, Pl. 54) and the habit of decorating a panel with the repeated pattern either side of a central midrib as on the wheel arcs on Faces B and D of Ahenny I, Ahenny II and Kilkieran II is paralleled on the pin of the Tara brooch (op cit, Pl. 13). The stylistic detail of elongating the plaitwork patterns is also a metalwork trait, examples being evident on the St Germain Plaques and the Loch Erne shrine (op cit Pls. 25, 26, 9).

On Kilkieran II the comparisons with chip-carved plaitwork are not apparent but other parallels with metalwork are. The simplicity of the pattern, the unevenness of the strand and the unaccountable mistakes are also found in later metalwork where spirals are a rare commodity and interlacings become 'dry and monotonous' (Henry 1967, 131). Some of the interlace designs belonging to the late ninth or early tenth century phase of the Kells Crozier (MacDermott 1955, 106, 81) are surprisingly similar to patterns on Kilkieran II. The panel on the lower binding strip (op cit Pl. XXXIb, 96) shows a small wheel-head cross. The cross-head is decorated with an uneven mesh of plaitwork strands similar to Kilkieran II C 1 and the four strand plait below is similar to some of the strands which are broken and rejoined on Kilkieran II D 5.

c) Fret Patterns and Related Ornament

Fret patterns are not used extensively amongst the Ossory crosses. Proper fret ornament is confined to Ahenny I and II but there are also related angular designs on Kilkieran II and possibly Lorrha I.

On Ahenny I fret patterns are used to decorate the shaft panel, A 3, and the wheel arcs on A 1. The pattern on A 3 is complex since the Z and auxiliary  elements are outlined in relief while the diamonds, which are used as fillers, are recessed. The effect is to obscure the actual form of the fret elements at the same time as giving the pattern a similar sharp metallic style to the interlace and spiral ornament on this cross. This stylistic feature is paralleled on Clonmacnoise IV (see p 80) and also on some of the Pictish monuments, for example border patterns on the backs of Rosemarkie I and Nigg and a pattern on Tarbat VIII (Allen and Anderson 1903, III, Figs. 60A, 72A, 94; Henderson 1978, Pl. 3.2). The pattern itself has no close comparisons but similar fret patterns covering large rectangular areas are found on Gallen Priory I A 2 (see p266), Kilree and Killamery (see p135) and some of the more developed Pictish monuments, for example Rosemarkie I and Tarbat VIII.

The border pattern on the wheel arcs of A 1 is not continuous but is made up of separate units skilfully adapted to coincide with the curve of the wheel arc. The use of single units rather than an interlocking pattern may be compared with Clonmacnoise IV D 6 (see p 80). The actual pattern elements are identical to A 3; they are simply adapted to fulfil a different function.

The fret ornament on Ahenny II B 5 and D 5 is again made up of single units of pattern rather crudely carved.

The angular pattern on Kilkieran II B 3, although it has become much simplified, may be classified with the other fret motives (Bruce-Mitford 1960a, 225). The pattern on Lorrha I A 5, though severely weathered, may be similar. The pattern seems merely to consist of square and diagonal grids superimposed one on another but no further ornament has been added. The effect on the eye is of diamond shapes slashed with triangles. The dimensions of each diamond shape, 4.5 cm x 4.5 cm, may be significant since this is also the diagonal measurement between the crossing points on many of the plaitwork designs on this monument. This sort of pattern seems to demonstrate the sculptor's knowledge of constructional grids even if he did not choose to employ them elsewhere. The closest parallels for such designs lie in manuscript illumination. There are examples identical with Kilkieran II B 3 in the Lindisfarne Gospels (f95 R) and similar patterns in the Book of Durrow (e.g. Nordenfalk 1977, Pl. 14). It is possible that the background to this kind of ornament could lie in millefiori patterns which may be exemplified by examples on the Oseburg Bucket and the Moylough Belt Shrine (Henry 1965, Pl. 91; O'Kelly 1964, Pl. 30).

d) Step Patterns and Related Designs

There are few step patterns on the Ossory monuments. Indeed, there are only two monuments which may be described as having proper step ornament, the single step unit on Kilkieran I a A 1 and the row of double step units on Mona Incha I A. These may be compared with the repertoire of step ornament on Kilree and Killamery where such patterns are far more prolific (see p137). The stylistic detail of ornamenting the centre of the step unit with a spiral as on Kilkieran I a A 1 is paralleled on Killamery A 15. The position of the pattern on the base of Mona Incha I may be compared with Killamery C 8 and Kilree D 8.

There are several designs which may be described as relating to step patterns. These consist of combinations of square, rectangular and 'L' shaped blocks which are found on Ahenny I, Kilkieran I and Lorrha I. In addition there is an unusual crenellated pattern on Ahenny II B 4.

On Ahenny I these patterns are used to decorate one shaft panel, C 3, and less conspicuously areas of the butt, A 4, and base, A5. C 3 (Fig. 21) is very simply constructed each square and 'L' shaped block being outlined in relief making the pattern appear sharp and clear cut. However, unlike most of the abstract ornament on this cross, these patterns do not owe their origins to chip-carved metalwork but rather to a type of Vernacular Style

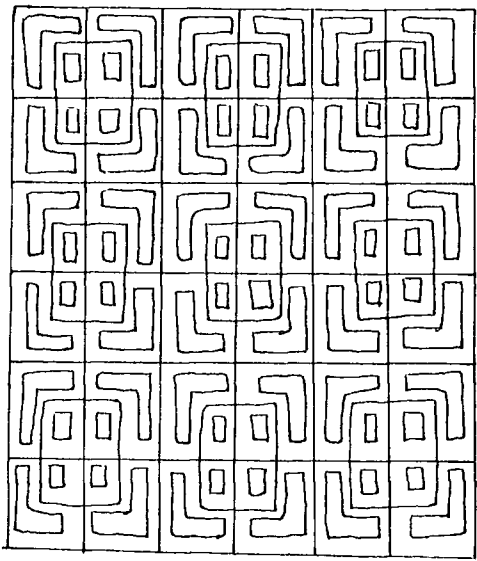

1

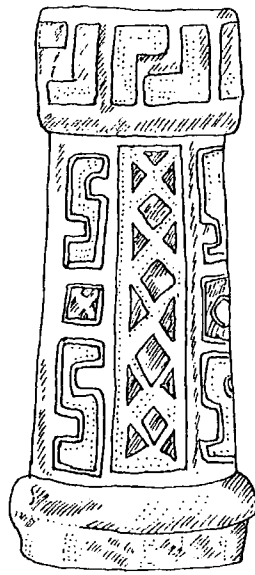

2

Fig 22

1 AHENNY I C 3

2,3 EKERÖ CROZIER

4 COPENHAGEN SHRINE

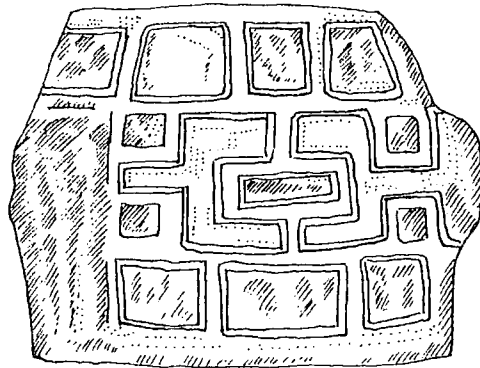

3

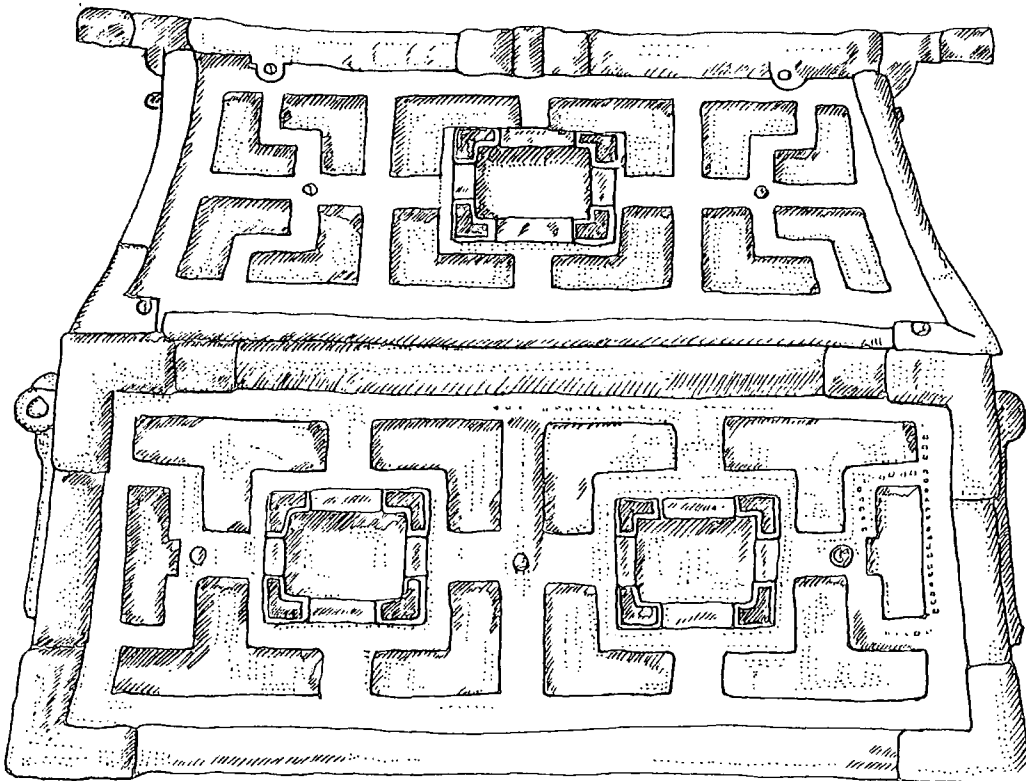

4

metalwork which make use of millefiori and champlevé enamel combined with high relief castings (Henry 1965, 104-6) (Appendix 2). The Ekerö crozier (Holmquist 1955) (Fig. 22) provides a good example of an object which makes use of both enamel work and chip-carved ornament in the same way as Ahenny I does in stone. The shaft and surviving knop are decorated with 'L' and 'S' blocks and step pattern shapes all inlaid with yellow enamel. However the actual form of the Ahenny pattern comes closest to that on the Copenhagen shrine (Mahr 1932, Pl. 16) (Fig. 22). Similar effects are found on the Moylough Belt Shrine (O'Kelly 1964, Pl. 13) and on the handles of the Ardagh chalice (Henry 1965, Pl. C).

The other patterns in this grouping, Ahenny I A 4 and 5, Lorrha I C 5 and Kilkieran I a A 2, are all much simpler. They may be compared with a similar background and in particular with the small mounts decorated with enamel and millefiori mainly associated with hanging bowls and buckets. These may be exemplified by the escutcheon mounts on the Mikebostad bowl and Oseburg bucket (Petersen 1940, 100, 87). Ahenny I A 4 also has parallels in manuscript illumination on f94V of the Lindisfarne Gospels.

The crenellated pattern on Ahenny II B 4 is unparalleled in sculpture, metalwork or manuscripts and therefore its origins remain obscure. It is slightly different from other patterns in this section as it seems to be constructed on the diagonal.

e) Zoomorphic Ornament

Zoomorphic ornament is little used amongst the Ossory monuments. Only three motives are represented: pairs of confronted dragonesque heads on Kilkieran I b A 3 and Ahenny II A 2, bird-like creatures with spiralled bodies on Kilkieran II A 3 and an anthropomorphic panel on Ahenny I A 2. In addition there are possible zoomorphic heads on the central boss of Ahenny I A 1.

The pairs of confronted dragonesque heads on Kilkieran I b A 3 and Ahenny II A 2 have many aspects in common even though they are carved in two very different styles. They both belong to a much broader spectrum of dragonesque and related serpentine motives (see pp 62, 138). Suffice it here to draw attention to the main analogies. The dragons on Ahenny II A 2 clearly owe their origins to Vernacular Style chip-carved metalwork. The best parallel is provided by the top from a bell shrine, now in the National Museum, Dublin (Henry 1965, Pl. 90). Here the dragons confront each other either side of a human orans figure. Like the Ahenny II dragons these have curled jaws and their necks are hatched, either

diagonally or with herring bone ornament. There is a spiral inset at the base of the neck. The necks of pairs of confronted dragonesque quadrupeds on the ends of the St Germain plaques (Mahr 1932, Pls. 25, 26) and the serpentine beasts on the Romfohjellen mount (Henry 1965, Pl. 90) are also ornamented in this way. The placement of the motif at the top of the shaft on Ahenny II A 2, used in conjunction with bosses and plaitwork patterns, may be compared with Bealin A 2, a similar dragonesque motif placed in an identical position (see p 62).

The Kilkieran I dragons are much more snake-like with their long almost beak like snouts and slender necks. It is not clear whether the rectangular grill placed between them is part of or distinct from them. If the former is so this motif may perhaps be compared with a pair of confronted birds with a similar object placed between them on Ahenny I C 6. Otherwise their form has more in common with the serpents on the Romfohjellen mount.

Both the Ahenny II and the Kilkieran I dragonesque heads have a round object placed between their gaping jaws. Similar motives are not uncommon in Pictish sculpture, for example Aberlemno II, Monifieth and Dunfallandy (Allen and Anderson, 1903, III, Figs. 227B, 242B and 305 B). It is, however, unclear what the round object is but it may be derived from a motif consisting of two confronted dragonesque heads with a human head placed between their gaping jaws. This feature has already been noted on the bell shrine fragment from the National Museum, Dublin and there are variations on the St. Germain Plaques (Mahr 1932, Pls. 25, 26), a cross slab from Gallen Priory (Henry 1965, Pl. 65) and the Ardchatten slab from Argyle (Allen and Anderson 1903, III, Fig. 393).

The bird-like creatures with spiralled bodies on Kilkieran II A 3 are closely related to the processions of birds and quadrupeds with spiralled bodies so characteristic of the Clonmacnoise group (see p 65). Here the motif, which should probably be turned through 90°, is very much simpler but the essential spiralled body element is still quite clear. It may be compared with the border pattern on the chi-rho page in the Lichfield Gospels (Nordenfalk 1947, Pl. 23) which is decorated with pairs of quadrupeds with long spiralled bodies and crossed necks.

The anthropomorphic interlace pattern, Ahenny I A 2, is similar to that on Banagher A 3 (see p 69). However the men on Ahenny I A 2 do not have long hair or beards. Nor are they reminiscent of manuscript illumination. They have more in common with other sculptural panels on the Market Cross, Kells (Roe 1966, 42; Henry 1933, Fig. 46d) and Meigle XXVI (Allen and Anderson 1903, III, Fig. 319). The only other parallel is

provided by a metalwork mount from Togherstown, Co Westmeath, where the three crouched figures also have short hair and are beardless (Fig. 17).

It is possible that the cruciform motif on the central boss on Ahenny I A 1 is composed of four zoomorphic heads with open mouths viewed from above. The use of zoomorphic ornament in such a position is also found on the cross at Kildalton, Islay (op cit, Fig. 410) where the animals are also viewed from above. Parallels for this motif are discussed in detail in connection with the displayed beast on Killamery C 1 (see p140).

3) Figural Panels

Figural scenes on these monuments are confined to the cross bases and therefore they always appear subordinate to the abstract ornament. On Ahenny I and II all the large base panels are figural but on Kilkieran II, Lorrha I, Seir Kieran and Mona Incha I there is a mixture of figural and abstract ornament. This mixture may be compared with Clonmacnoise IV (see p 86).

The figural panels on Ahenny I are relatively well preserved but the bases of the other Ossory monuments have suffered severe weathering and the fragmentary remains of figural iconography is not always easily identifiable. Sier Kieran D 3 in particular at first sight appears completely incoherent but upon close examination in good oblique light a number of scenes may be identified (Fig. 23). It is also evident by examining old photographs (e.g. Henry 1933, Pl. 34) that the carving on the base of Ahenny II has deteriorated considerably in recent years. This renders Helen Roe's (1962, 23-4) interpretations of the iconography unverifiable.

The figural scenes represented may be divided into three different types. Firstly, there are scenes which are undoubtedly Scriptural. Secondly, there are some scenes which are unlikely to be Scriptural but which do appear to have some kind of Christian significance. Lastly, there are several panels where the iconography, chiefly hunting scenes, could be of a more secular nature although one cannot rule out the idea of religious symbolism or allegorical significance.

a) Ahenny I

The iconography on the base of Ahenny I is complex and problematical and for this reason it has given rise to much discussion.³

The identity of A 7 has been the subject of several fanciful speculations. Porter (1931, 22) suggested that it showed Bishop Cormac mac Cuillennin, a bishop of Cashel at the turn of the tenth century, and six other bishops who were his supporters. Elizabeth Hickey (1955, 118-21)

interpreted it as part of a cycle of scenes on the cross depicting various episodes from the Life of Art, son of Conn and King of Tara who, according to the Book of Leinster, died c 195 AD. In local tradition it is associated with the story of seven bishops, who were murdered in the area (Stokes, M.M. 1901, 576 ff; Henry 1945, 257-60). But more likely than any of these is Helen Roe's suggestion (1962, 19; Henry 1965, 151) that the panel shows Christ's Mission to the Apostles. She suggests also (op cit, 23-4) that there is a similar scene on Ahenny II C 4 but this is now unverifiable ^{owing} due to weathering. Another possible parallel is to be found on Clonmacnoise V A 17 (see p237) and there are related scenes amongst the Barrow Valley crosses (see p190).

This, together with similar scenes showing Christ Enthroned with His Apostles or teaching them, are common in Early Christian iconography. For example, on the late fourth century Sarcophagus of Stilicho (?) from Milan Christ is shown standing face on, with six Apostles seated on either side looking towards Him (Beckwith 1979, Fig. 30). He may also be shown standing face on with the Apostles standing either side of Him placed between pillars (e.g. Gough 1973, Fig. 89).⁴ There are also several examples on the Gaulish sarcophagi where Christ, the central figure, is shown face on either standing or seated while the Apostles, frequently standing in ones or twos under arches to either side, process towards him (Le Blant 1886; e.g. Pls. 19, 22).

Therefore Ahenny A 7, if the identification is correct, would seem to be a version adapted to the Early Christian Irish environment, the Apostles being represented as ecclesiastics with croziers. They are dressed in long robes and cloaks with hoods. The form of the latter suggests they are wearing a kind of chasuble called a casula which was a common form of outdoor dress for clergy and monks of certain monasteries from the fifth to the eighth centuries (Norris 1949, 60-2), being retained in some places into the Carolingian period (Cadbrol and Leclercq 1907-53, III.1, 1192). Ecclesiastics wearing similar apparel are also quite common on the Pictish Class II and III monuments (Allen and Anderson 1903, II, 407), the best comparison being provided by two ecclesiastics shown in profile, processing one behind the other, on St Vigeans VII (op cit, III, Fig. 278).

Ahenny I C 7 has been variously identified as Adam naming the animals (Crawford H.S. 1909c, 259) or a hermit in retreat (Henry 1965, 152-3) as well as rather wilder attributions (Porter 1931, 12 note; Hickey E. 1955, 121). The first, better entitled the Garden of Eden, is by far the most likely even though Helen Roe (1962, 14-15) was dissatisfied with it because

the figure is clothed and the beasts have much in common with oriental decorative motives and Bestiary illustrations. The best parallel is provided by a scene from the Genesis Cycle of the Bamberg Bible now in Tours dated to the second quarter of the ninth century (Beckwith 1969, 61, Fig. 50) (see p231). This scene, which may be derived from a late antique manuscript, depicts God showing Adam the animals in the Garden of Eden. On the left hand edge of the scene is a tree. Immediately to the right of this God is shown in long robes and a halo pointing to the animals with an outstretched right arm. In the centre are a jumble of animals including a snake, a stag, a camel and a variety of birds. On the right side is Adam shown in profile facing left. Perhaps the clothed figure on Ahenny IC7 would make more sense if it is interpreted as God rather than Adam who has perhaps been left out owing to lack of space. A second possible parallel may be cited with a North Italian ivory diptych dating to the end of the fourth century now in the Museo Nazionale, Florence (Gaborit-Chopin 1978, Fig. 13). Here Adam is shown reclining, grasping a tree in his left hand, and viewing a number of animals grouped before him: an eagle, lions an elephant, a boar, a goat, a horse, an ox, a snake and a stag.

The iconography of B 9 and D 9 is even more problematical. The former is clearly a funeral procession (see p 42) but to whom it relates is unknown. Porter (1931, 112) associated it with the funeral of Cormac mac Cuillenain who died in 908, a theory which is untenable because of the form of the abstract ornament on the cross. Helen Roe (1962, 22) suggested that it could show the funeral of a saint or King Saul who was murdered by the Philistines, an episode from the David Cycle. All one can really say is that this scene may provide a valuable illustration of a funeral procession as it might have been conducted in Early Medieval Ireland. The leading figures, the first clad in similar garments to the figures on A 7, the second carrying a processional cross (see p 32) and possibly a third with his staff or crozier would seem to be ecclesiastics. The headless figure preyed on by crows or ravens is a pictorial example of events described in Celtic heroic literature such as the Táin (Kin}sella 1969, 238) and the Gododdin (Jackson, 1969, 41, 99, 117, 126). The decapitation of the slain on the battlefield is accepted as a Celtic custom and Anne Ross (1967, 122; 61-126) has fully explored the pagan religious significance of the cult of the head. Ravens and crows are also connected with pagan Celtic religion, particularly with a trio of Irish war goddesses, one of whom is frequently called baeb or 'crow' after the form she took while another, the Mórrígan, is associated with ravens (op cit, 219, 244, 294). These goddesses in

their bird forms were prophetic of death or disaster on the battlefield (op cit, 247, 257) and in the same guise are also associated with severed heads (op cit, 244, 122). Thus the appearance of the decapitated body preyed on by crows or ravens on Ahenny I B 9 may indicate a hangover into the Early Christian Period of earlier but deep rooted beliefs.

Both the headless body slung over the horse or ass and birds devouring bodies are found elsewhere in Hiberno-Saxon art. The former appears in a simplified version on the crosshead at Dromiskin, Co Louth (Henry 1965, Pl. 82; Roe 1954, 113) and also in Pictland on St Vigean's XXV (Allen and Anderson 1903, III, Fig. 296) where it is not entirely clear whether the body is decapitated. The latter is found on the famous battle-scene on Aberlemno II (op cit, III, Fig. 227B) where the fallen warrior is preyed upon by an eagle-like bird and crow-like birds are also depicted on the curious insular Crucifixion scene in the Würzburg Gospels (Würzburg Universitätsbibl. M.p.th.f61) (Masai 1947, Pl.34).

Both B 9 and D 9 have been connected with the cult of relics (Henry 1965, 152; Roe 1962, 16, 45, Fig. 6). For the latter, a procession with horsemen and a chariot, this association seems slightly more plausible. Helen Roe compared it with a probably sixth century Byzantine ivory showing a translation of relics in Constantinople now in Trier Cathedral Treasury (Beckwith 1979, Fig. 74). On this a procession of footmen and a cross bearer, set against the background of a crowded street, lead a chariot with two occupants, one clearly holding a house-shaped shrine. Unfortunately no shrine is visible on Ahenny I D 9, although it is known that in Ireland relics were taken round for exhibition (commutatio) (Hughes 1966, 167-9) so the parallel will remain unproven. In addition Peter Harbison (1969, 53-4) has suggested that this panel may follow on from the funerary scene on B 9, although the two panels are not on adjacent faces, and may represent the mourners accompanying the procession. However, whatever the precise meaning of the procession, it is undoubtedly of religious significance as the leading horsemen are clad in clerical garb. It is unclear whether the two figures in the chariot are secular or clerical.

The form of the chariot represented has led to a considerable amount of discussion since it appears to be a depiction of the chariot which first came into use in Ireland during the Iron Age. Peter Harbison (1971, 174) has suggested that there is a fundamental difference between the fast moving Continental chariot which may be exemplified in Britain by Llyn Cerrig Bach and the more cart like vehicle adopted in Ireland. David Greene's study of the early Irish literary references to chariots has

described the chariot or 'carpat'

'as a simple two wheeled cart, containing two simple seats in tandem in a light wooden frame and drawn by two horses harnessed by bridles to a yoke attached to the chariot pole; the wheels were shod with iron tyres'
(1972, 70)

This seems to fit the Ahenny representation exactly. One feature shown on the crosses but not mentioned in the literature is the very large spoked wheels which Harbison (1971, 173) believes indicate that the chariots were drawn by ponies rather than horses and also that the chariots must have been very high off the ground, perhaps a metre. The idea of the spoked wheel may have been transmitted from the Celtic chariot or via Roman influence. He has also indicated that 'the Ahenny chariot shows the earliest known appearance in Europe of the Chinese invention of the breast strap or 'postillion harness' (op cit, 174). The prancing horses are reminiscent of Banagher A 1 (see p 85).

In addition Greene (1972, 60) and Harbison (1969, 50-1) have shown that such chariots were not only used in war. They were rather a method of transportation for the upper classes, kings, nobles and, in the Early Medieval Period, ecclesiastics also. Indeed it is recorded in the Annals of Ulster (1020) that a chariot was still used by the Abbot of Armagh in the eleventh century.

Similar processions with horsemen and chariots are also found on other Irish crosses where they usually appear on the base. The version on Kells South seems to be a simplification of Ahenny I D 9 (Roe 1966, Pl. IV). Two horsemen, a dog and a chariot are shown but on a very much smaller scale. There are other chariot scenes on Killamery A 5 (see p152) and Clonmacnoise V C 18 (see p238). In Pictland there is a single example of a chariot of more complex structure with a canopy on Meigle X (Allen and Anderson 1903, III, Fig. 344).

On a more general note Peter Harbison (1978, 288ff) has attempted to demonstrate strong affinities between the style of the figural panels on Ahenny I and English bone carving as exemplified by the Franks Casket. Both have wide ranging iconography and a sense of horror vacui but it does not really seem possible to compare them more closely. All that can be said is that they must have been subject to similar influences. What is interesting however is the range of models that must have been available for the craftsman of the Franks' casket to draw upon (Becker 1973, Kendrick 1938, 122). Presumably a similar variety would also have been available in Ireland.

b) The Help of God Symbolic Cycle

Several Old Testament scenes may be identified on Seir Kieran D 3: The Fall, the Sacrifice of Isaac and the Three Children in the Fiery Furnace (Fig. 24). The figures of (iv) have now been almost completely obliterated but Helen Roe, who helped excavate the stone in 1937 when it was apparently less weathered (Cunningham 1976, 68) suggested (1949, 51, Fig. 7) this scene was David, the figure on the right, handing the head of Goliath to King Saul. There is no evidence for a representation of Jonah and the Whale as has been suggested by Françoise Henry (1965, 147). Helen Roe (1962, 23-4) identified other Old Testament scenes on Ahenny II. The fragments which survive on C 3 may be Daniel in the Lions' Den (op cit, Pl. 10) but B 6, which she suggested was the Fall, is now completely lost. It seems possible that Lorrha I C 4 could be a misunderstood version of Daniel in the Lions' Den where the figure of Daniel has been placed at one end. The beasts are probably lions; they are clearly not horses as Françoise Henry (1933, 115; 1940, 105) has suggested. If the suggestion of Daniel is incorrect these beasts may be compared with the exotic beasts found on the Clonmacnoise monuments (see p81). Françoise Henry's suggestion (ibid) that it is Noah summoning the animals into the Ark is unlikely as only one species of animal is represented and there is no indication of the Ark.

Representations of the Fall, the Sacrifice of Isaac, the three Children in the Fiery Furnace and Daniel in the Lions' Den are all frequently found on the Irish crosses (Fig. 23). The closest parallels for those on Seir Kieran D 3 are provided by Kells South (Roe 1966, Pl. II). The Fall on Kells South is accompanied by the Death of Abel and it seems possible that this may once have been shown to the right of Adam and Eve on Seir Kieran as well (see p230). The Children in the Furnace on Seir Kieran is a rather mangled version of that on Kells South where the two torch bearers are placed one on either side of the children who are grouped under the protection of the angel's wings. On Seir Kieran there are three torch bearers and they are all placed to the left of the children. The sacrifice of Isaac is also very similar on both monuments. The placing of such scenes on the base may be compared with Clonmacnoise IV B 12 (see p 88) and Bray (Conway 1975, 53-4).

These four scenes, together with Noah's Ark which is found elsewhere on Irish sculpture (Fig. 23), all belong to the Help of God Iconographical Cycle. Their use goes right back to the beginnings of Christianity. The

	The Fall	Sacrifice of Isaac	The Three Children in the Furnace	Daniel	Noah's Ark
Ahenny II	?			?	
Arboe	✓	✓	✓	✓	
Armagh	✓	✓	✓		✓
Bray	✓			✓	
Castledermot S	✓	✓		✓	
Castledermot N	✓	✓		✓	
Clonmacnoise IV	✓				
Donaghmore	✓	✓			
Durrow I	✓	✓			
Galloon East		✓			
Galloon West	✓		✓	✓	?
Galloon Crosshead				✓	
Graiguenamanagh I	✓	✓			
Kells South	✓	✓	✓	✓	
Kells Market	✓	✓		✓	
Kells West	✓				✓
Kilree				✓	
Kinnitty I	✓				
Lisnaskea	✓				
Lorrha I				?	
Monasterboice S	✓				
Monasterboice W		✓	✓		
Moone	✓	✓	✓	✓	
Seir Kieran	✓	✓	✓		
Ullard	✓	✓			

Fig. 23

Fall is depicted from a very early date because this is what made the Redemption necessary. Very early examples may be seen in the Catacomb of Janiarius in Naples and in the Baptistery at Dura (Gough 1973, 33, Fig. 27). Noah's Ark, the Sacrifice of Isaac, the Three Children in the Furnace, and Daniel in the Lions' Den, all scenes of deliverance, are frequently found either grouped or singly in the catacomb paintings and on sarcophagi both in Italy and Gaul (op cit, Figs. 29-31, 34-5; Le Blant 1886, 93). Other scenes of deliverance not found in Ireland are also depicted particularly scenes from the Life of Jonah and the Accusation of Susannah (Gough 1973, Figs. 34, 36-7; Beckwith 1979, Fig. 10).

The reason why these scenes of deliverance were so popular in the funerary context may be seen immediately when the liturgical background is examined. This has been studied in some detail by Le Blant (1878) in connection with his study of the iconography of the Christian Gaulish sarcophagi. The episodes illustrated are all part of the ordo commendationis animae, the prayer for deliverance said to the dying which was adapted by Cyprian of Antioch during the second century AD from a Jewish prayer recited on fast days (Michel, K. 1902). The earliest version of the ordo commendationis animae in Latin survives in the eleventh century⁵ Troyes Pontifical (Troyes Bibl. Municipale cod. 2272) (Flower 1954, 92; Vogel 1975, 205).

However three versions of a similar prayer for deliverance are also known from Ireland. They have become separated from the ordo commendationis animae and in two cases they have been translated into Irish but their ultimate roots in the Latin ordo remain perfectly clear. In the Irish context they seem to be used 'as a general apotropaic formula against all evil' (Flower 1954, 92) (see p 41). The first version forms the latter part of the Epilogue to the Félire Oengusso (Martyrology of Oengus) which Whitley Stokes (1905, VII) dated to c 800. It is known that the author, Oengus, was for some time a follower of St Maelruain or Tallaght a leader of the Céli Dé movement.

The second is the Hymn of St Colman, a prayer for protection against plague, from the Liber Hymnorum which linguistically would seem to be of approximately the same date as the Félire Oengusso (Flower 1954, 92). The prayer is followed by a Latin collect which suggests it was used liturgically. The third example, in Latin rather than Irish, is also liturgical since it forms the preface to the Ordo Missae. It survives in the Stowe Missal (Dublin, R.I.A. Ms. D.II.3), an early service book possibly associated with some monastery in Tipperary founded by St Ruadhan of Lo rha (Warren 1881, 198ff) Most of the service book has been ascribed on liturgical grounds



(iv) DAVID PRESENTING THE HEAD OF GOLIATH TO SAUL (?)
(After Roe)

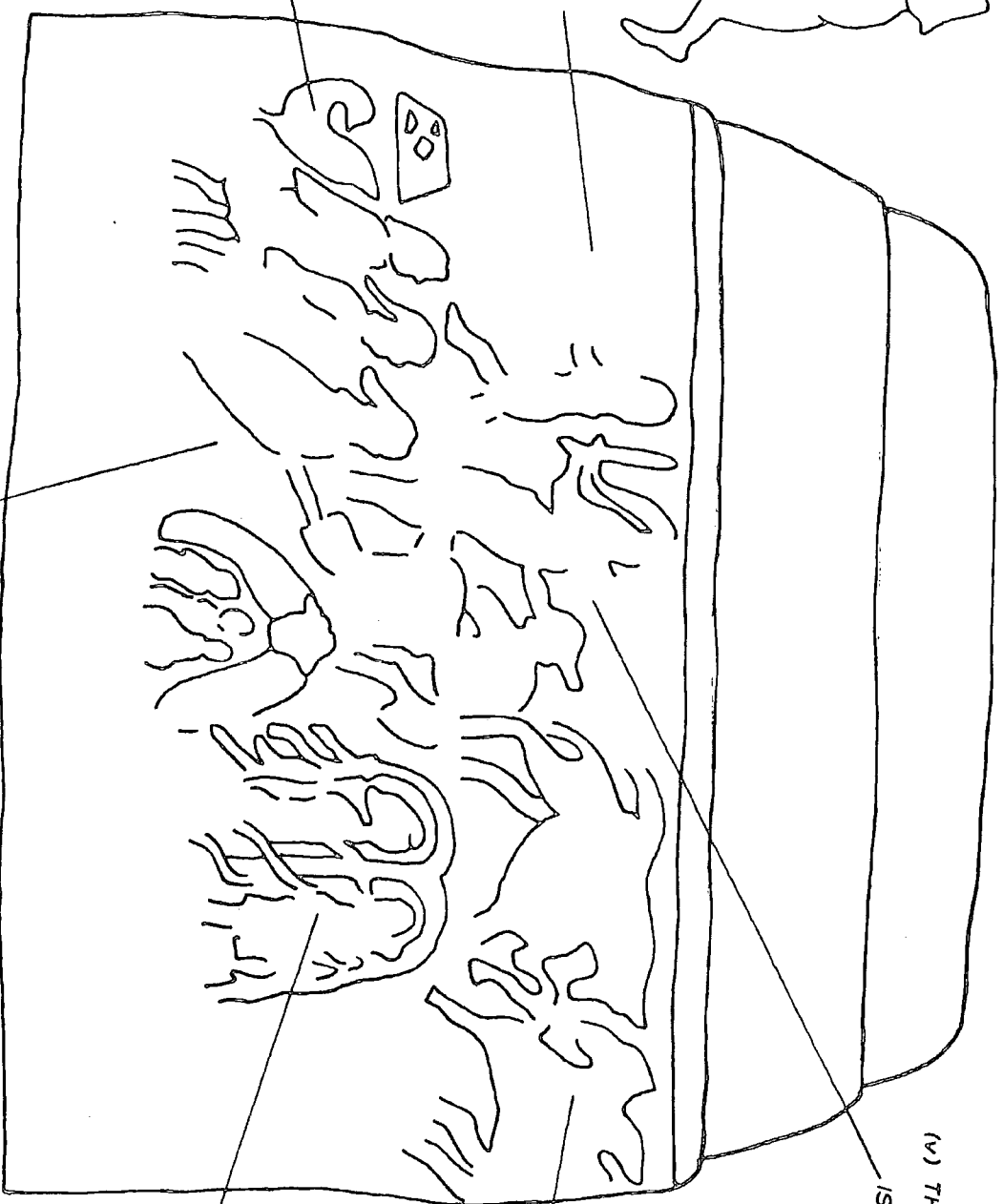

(v) THE SACRIFICE OF

ISAAC

(vi) WINGED (?) HORSES

(i) THE FALL

(iii) BIRD

(ii) THE CHILDREN IN THE FIERY FURNACE

Fig 24 SEIR KIERAN D 3

to the ninth or tenth centuries. The relevant passages of all three texts are quoted in full in Appendix 4. Other aspects of the importance of the deliverance theme may also be hinted at, for example in some of the canticles in the Antiphony of Bangor and in Anglo-Saxon England aspects of the Exodus and Daniel also show its significance (McLoughlin 1969). It is interesting to note that the emphasis in Daniel is on the narrative portions of the story including Daniel's struggles and deliverance from the Lions' Den and the Three Children's deliverance from the Fiery Furnace.

The survival of these texts suggests, as Françoise Henry (1967, 144) has already stated, that various theories of deliverance would have been familiar to the Irish churchman and generally recognisable in the iconographic context. However, the idea that the sculptor was actually illustrating such prayers seems unlikely as only the same few scenes are repeated over and over again and these are the ones also found in the Early Christian art of Italy and Gaul. Where the precise models came from for their representation in Irish art is more problematical. Although generally popular in the early days of Christianity they seem to fall into disuse during the seventh and eighth centuries. Radford (1977, 114) has suggested that the insular world could have received such iconography in the fifth or sixth centuries and kept it alive on wooden sculpture up until its appearance on stone. This seems most unlikely. Far more possible explanations may be sought in the idea that Irish churchmen visiting the Continent or Rome could have brought back with them early ivories or other portable objects or at least seen paintings or sarcophagi with these subjects depicted on them.

The Fall, the Sacrifice of Isaac and Daniel in the Lions' Den may also have other meanings as well as their significance within this cycle. This is discussed in detail on pages 181, 230, 231, 147.

If Helen Roe's interpretation of Seir Kieran D 3 (iv) as David presenting the head of Goliath to King Saul is correct, although it may be considered as part of the David cycle (see p151) its placement with the Help of God scenes is not completely anomalous as God's aid is sought in the Féilire Óengusso (1483-4) and the Hymn of Colman for the deliverance of David from Goliath. This aspect of the David Cycle is unparalleled elsewhere in Ireland but the act of presenting a severed head might well continue to appeal to the Celtic mind (see p118).

c) Hunting Scenes and Related Iconography

These are found on Ahenny II B 7, D 6 and D 7 and Mona Incha I A.

The scenes on both cross bases are badly weathered but from the fragmentary carvings which survive it is clear that they show elements from hunting scenes set out in a somewhat haphazard manner. The aim of the sculptors seem to have been to fill the available space with huntsmen and animals but a coherent picture is not necessarily created in so doing. On Ahenny II D 6 the course of the hunt has been reversed; the bears are now pursuing the horsemen.

This kind of hunting scene is well represented on many of the Irish crosses, usually appearing on the base and, like the hunting scenes on the Clonmacnoise monuments (see p 84), they fit into the same milieu as those in Pictland, although it is not possible to cite particular parallels. However, the bears on Ahenny II D 6 are unusual. They are not paralleled elsewhere in Ireland but in Pictland there are three bears on Meigle XXVI (Allen and Anderson, 1903, III, Fig. 318B) although here they are not connected with a hunting scene. It seems that in Ireland the bear was extinct before the beginning of the historic period (Harting 1880, 16ff) although it would still have been possible to hunt bears in the rest of the British Isles during the eighth century. It is not impossible that the sculptor was acquainted with wild bears but it seems far more likely he was drawing on a foreign model, perhaps some Roman venatio or amphitheatre scene which frequently includes bears (e.g. Dorigo 1971, Pl. 148).

On the base panels of Kilkieran II C 5 and C 6 there are eight horsemen. On Lorrha I this motif has been simplified to form a procession of miniature horses which parade round the second step of the base on all four faces: A 2, B 2, C 2 and D 2. The same horse procession has already been pointed out on Clonmacnoise IV A 7 (see p 86). They may perhaps be compared with a similar procession of four horsemen on the base of the Market Cross, Kells (Roe 1966, Pl. VII) but these are much more spirited. Porter (1931, 23) identified them with the seven bishops legend which is clearly untenable (see p116). They should rather be regarded as a motif which is used in a similar way to the hunting scene.

Single horsemen and groups of two or three form a common motif in Pictland on both Class II and III monuments where they are usually found on the backs. This is not a closely knit group since the horsemen sport a great variety of attributes and cannot be very closely compared with any of the Irish examples but their popularity in both Ireland and Pictland may be a reflection of the Celtic love of horses and horsemanship. The stylistic detail of foreshortening the rider's body due to lack of

space found on Kilkieran II C 5 and 6 is a characteristic feature of many of the Pictish horsemen exemplified by St Madoes (Allen and Anderson, 1903, III, Fig. 309B) and is also found in the Book of Kells, f89R.

On Seir Kieran A 3 four marching footmen holding spears are shown confronting a mounted horseman. This is the only definite example of a potential battle scene in Ireland (see p238) but again the parallels are to be found in Pictland. The second register of the battle scene on the back of the early Class II slab Aberlemno II provides a good comparison (op cit, Fig. 227B). Here four men are shown in profile facing right confronted by a mounted horseman with a spear and protected by a helmet and shield. The footmen, clad in tunics, brandish spears or swords and shields. There are further examples on the fragment from Dull in Perthshire, which shows a procession of infantrymen with tunics and shields followed by horsemen with spears and shields, and the back of Sueno's stone, a rather later Class III monument (Henderson 1978, 53), is peopled with an army of small armed figures (op cit, Figs. 329, 156A).

Both the origins and the possible meanings of hunting scenes and related iconography are difficult to ascertain. Since they are positioned on crosses one would clearly expect a Christian meaning. Richard Bailey (1977, 68-71) has studied in some detail the probable religious significance of harts pursued by hounds. The stag itself was early adopted by Christian commentators as a symbol of Baptism or Christ Crucified (Reau 1955, 82; Cadbrol and Leclercq 1907-53, II, 2, 3302) and it is also popularised in Christian Encyclopedias and Bestiaries for its enmity against serpents (see pp160,266). Richard Bailey has also emphasised the importance of the hart and hound in the iconography of the Psalms, an essential part of the daily monastic liturgy. In particular, he has drawn attention to the illustrations in the Carolingian Utrecht Psalter which show a stag pursued by hounds representing evil. In this light it seems possible that the Irish hunting scenes may have had similar religious connotations.

As Richard Bailey (1977, 70) has said the most likely ultimate source for hunting scenes is Christian Mediterranean art. It is known that the stag hunt was adopted into Early Christian iconography at an early date (Allen and Anderson 1903, I, XLVI) and in Southern Gaul the popularity of hunting and pastoral scenes, frequently interspersed with overtly Christian iconography, continued on sculpture into the sub-Roman period (Stevenson 1955, 106). These may be exemplified by sarcophagi from Clermont and Loudon

in Aquitaine (Le Blant 1886, Nos. 88, 95, Pl. 23; Fossard 1953, 117, Pl.2) and other late seventh or early eighth century plaques from the area round Narbonne (Durliat 1953, 98-9, Pl. 2). In addition iconoclasm in Byzantium brought a revival in classical mythical iconography including scenes of the chase (Dalton 1911, 15) and this influence travelled to Italy during the eighth century where it may be exemplified by hunting scenes at San Saba in Rome and at Civita Castellana (Hubert et al 1969, 257).

However, the idea that some of the hunting scenes and related iconography is purely secular cannot be entirely ruled out. It is also possible that, although such scenes originally had a Christian meaning, by the time they were reproduced on Irish sculpture, this had been largely forgotten. Since Irish Christianity was extraordinarily tolerant of secular learning (Hughes 1966, 154) there seems no reason why hunting scenes, which may have had little Christian significance, could not have become a popular motif.

One important aspect to bear in mind is the Celtic love of hunting. This is well illustrated in the Irish source material, a good example being the Crith Gablach, an early eighth century compilation, where sport, of which one aspect was hunting, is considered an essential part of noble life (Hughes 1968, 16). The adoption of scenes showing warfare on the crosses could also reflect the Celtic preoccupation with fighting.

Animals of the hunt are also an important aspect of pagan Celtic religion. Boars, stags, horses and perhaps bears are frequently represented in pagan Celtic art (Finlay 1973, 70, 95; Ross 1967, 297 ff).⁶ Isobel Henderson (1967, 134-7) has also hinted at the possible importance of embroideries illustrating heroic deeds although the only actual survival is the Oseburg ship tapestry (Jones 1968, Pl. 21) which is rather removed from the Celtic milieu.

Again, Roman hunting scenes, this time in their secular context, would seem to provide one of the likely origins. In Roman Britain Jocelyn Toynbee has pointed out the popularity of Nene Valley ware, which was frequently decorated with hunting scenes, and traded to other parts of Britain including the Hadrian's Wall area. She says, 'there can be little doubt that this theme made an especial impact on the hunt addicted Celtic population' (1964, 408-9). There is also evidence that Roman hunting scenes reached Ireland. A silver dish fragment from the Balline hoard, Co Limerick, ascribed to the fourth century, shows three horsemen which are clearly part of a larger hunting scene (Bateson 1973, 73-4).

Therefore, while some Christian symbolism seems likely for the hunting

scenes and related iconography one cannot rule out other, more secular possibilities. It may simply be that Christian hunting scenes were frequently represented because of the more general popularity of the sport of hunting in the Celtic world.

Conclusions Undoubtedly the closest parallels for the figural iconography on the Ossory crosses are to be found in Pictland. Firstly, the iconography is detached from the actual form of the cross. On the Ossory monuments it is found on the base while on the Pictish slabs the majority is confined to the back or is placed to either side of the cross on the front.

Secondly, the figural panels on the Ossory crosses and the Pictish slabs are composed in a similar way. As has already been noted amongst the Ossory crosses the animals and figures are placed so as to cover the entire panel without a space. This may also be seen in Pictland, for example on the back of the 'Boss Style' slab from Shandwick where various elements of hunting and combat scenes are jumbled together including a stag in the bottom right hand corner which is actually placed on the diagonal (Allen and Anderson 1903, III, Fig. 70). This may be compared with Ahenny I C 7 where the quadruped in the bottom right hand corner is placed vertically in order to fill the available space. Scriptural scenes are treated in the same manner. The episodic character of the David Cycle scenes on the St Andrews sarcophagus may be compared with The Help of God scenes on Seir Kieran D 3.

Thirdly, stylistic details are common to both groups. The preference for the figure in profile is only rarely broken in Pictland, for example the female rider on Hilton of Cadbol, Daniel on Meigle II and David on the St. Andrews sarcophagus (op cit, Figs. 59, 311B). The only face on representation on the Ossory crosses is the central figure on Ahenny I A 6. Attempts at perspective are also tackled in a similar way. On Hilton of Cadbol two mounted figures placed side by side are shown by doubling the line round the horse's head and legs. This is indicated in an identical fashion on the horse pulling the chariot on Ahenny I D 9.

The general similarities in the subject matter between the Pictish and Ossory monuments have already been pointed out. The only real difference is that the Scriptural iconographic repertoire is narrower in Pictland. For example Help of God scenes are only rarely shown and they are not grouped together. Daniel in the Lions' Den is depicted four times on Inchinnan III, Meigle II, Newton Woods and St Vigean's XIV (op cit, Figs. 478A, 311B, 481 and 285A) and in addition there are three examples

of Jonah and the Whale, which is not found in Ireland, at Dunfallandy and Woodwray (op cit, Figs. 305C, 258C). However, the repertoire in Dalriada does seem more similar. For example the Sacrifice of Isaac is found on Kildalton and Daniel on Kildalton, Keills and St Martin's Cross, Iona (op cit, Figs. 410A, 408, 397A).

Therefore it is clear that the sculptors of the Ossory crosses and the Scottish sculpture were working in a similar milieu and drawing upon similar sources. What those sources were is more difficult to ascertain but one suspects a variety of portable Christian objects, manuscripts, ivories, etc., additional material perhaps being drawn from the indigenous Celtic background or perhaps the background merely affected the choice of what was drawn from other sources.

4) The Dating of the Monuments

Unfortunately the only way of dating the Ossory crosses is on art historical grounds. In the past this has led to the suggestion of widely differing dates. Sexton (1946, 7-8) recognised the influence of metalwork on these crosses but, for some reason which demonstrates he cannot properly have examined the abstract ornament, he compared it with the decoration on the Cross of Cong dated c 1123 (Wilson and Klindt-Jensen 1966, 156-7). While it is true that many technical elements used on earlier metalwork are still present on this object, the ornament, in the Viking Urnes style, is completely different. Porter (1931, 112) suggested a terminus postquem of 908, the year in which Cormac mac Cuillenain whose funeral procession he identified on Ahenny I B 9, was murdered. It has already been noted (see p116) that this interpretation is completely unprovable. More recently A.P. Smyth (1979, 284-8) has attempted to examine the Irish crosses in terms of the political background which has led him to suggest the Ossory monuments belong to a period when the Kingdom of Ossory was particularly powerful at the end of the ninth century. This suggestion is hard to contemplate seriously as it takes no account of the actual ornament on the crosses. However, the majority of other writers following Françoise Henry have fixed upon an eighth century date because of the similarity of the ornament to Vernacular Style metalwork (Henry 1940, 103; 1965, 141; Roe 1962, 8-9) although H.S. Crawford (1926a, 5) was inclined to think them slightly later.

As the preceding discussion has shown the closest comparisons for both the form and ornament of the crosses are undoubtedly with Vernacular Style metalwork. As Françoise Henry (1940, 103) said 'they are first and

foremost enlargements into stone of metal crosses'. Peter Harbison (1978, 283 ff) has recently enlarged upon this theory, drawing attention to the Rupertus (Bischopschofen) Cross (see p 32) as a possible parallel for a metalwork cross which may have been the source of inspiration for the Ahenny monuments. These comparisons, however, are very superficial. Nevertheless, it does seem likely that the sculptor of Ahenny I was heavily dependent on some metalwork prototype, perhaps something akin to the processional cross carved on B 9, because so many skeuomorphic elements such as the rope mouldings reminiscent of metalwork bindings are retained. This view is perhaps underlined if it is imagined that the cross was once painted. There is now no visible evidence that the Irish crosses were painted but this monument, decked out in the colours of gilding and enamelwork, would surely then have appeared as a gigantic golden cross encrusted with insets of glass and jewels? Indeed, as has already been suggested (see p 31), the ultimate origins of this cross are most likely to lie in the crux gemmata.

The closest comparisons for the metalwork motives in use on the Ossory crosses, particularly Ahenny I and Ahenny II, are those carried out in a chip-carved technique or decorated with enamelled or millefiori insets or glass studs. There is one major example of an object incorporating both techniques, the Ekerö crozier (Holmquist 1955; Henry 1965, 104-6). More often the two are not intermingled but the comparisons cited have been with objects of the highest technical achievement, for example the Ardagh Chalice, the St Germain Plaques and the Derrynavlan patten stand. These comparisons with Vernacular Style metalwork would suggest that the Ossory crosses are of a similar date. Unfortunately it is impossible to pinpoint the date of any Vernacular Style metalwork (see Appendix 2) and so on these grounds the date of the Ossory crosses may be ascribed to any time during the eighth or early ninth centuries.

As Robert Stevenson (1956, 91-2) has hinted a more profitable line of approach may lie in the comparisons which may be made between the Ossory crosses and sculpture in Pictland and Dalriada. The Clonmacnoise monuments have many aspects in common with the early Class II stones of Southern Pictland (see p 90), but as has been demonstrated, the Ossory crosses show more affinities with the 'Boss Style' monuments and some of the more developed Class II slabs. The most important monuments which fall into these groupings are the freestanding crosses on Dalriadic Iona, a number of slabs from Northern Pictland, Applecross, Rosemarkie I, Shandwick, Nigg and the Tarbat fragments, and a more scattered distribution in the south including Aberlemno III, Meigle II and the St Andrews sarcophagus. The

monuments centring on Ross perhaps provide the closest analogies for the Ahenny crosses. On Nigg there is the same preoccupation with the complex perspective created by the use of bosses, prominent mouldings and recessed panels (Allen and Anderson 1903, III, Fig. 72). Rosemarkie I, Shandwick and the Tarbat fragments exhibit the same influence of chip-carved metalwork techniques and the tendency to decorate large areas with a single overall pattern and it has already been noted that the Shandwick figural panel had much in common with the Ossory monuments (op. cit, Figs. 60, 66, 70, 92-6). Pictish and Dalriadic sculpture in this period also shows the same tentative use of Scriptural iconography. The form of the monuments have much in common with the Iona crosses (Stevenson 1956, 91-2) although the position of the wheelarcs is better compared with Aberlemno III and Fowlis Wester (Allen and Anderson 1903, III, Fig. 228A; Curle 1939-40, Pl. XXVIIb).

There are enough similarities between the Ahenny crosses and the Dalriadic and Pictish 'Boss Style' and the developed Class II monuments to suggest an approximately contemporary dating. Robert Stevenson (1955, 117-20) has suggested c 800 for the masterpieces of Pictish 'Boss Style' and Isobel Henderson (1978, 49) has seen 'Rosemarkie I as a stone 'that looks forward to the last phase of Pictish sculpture', that is the ninth century monuments. It would therefore seem likely that, as with the Clonmacnoise monuments (see p 90), many of the influences detectable on the Ossory crosses may have originated in Scotland, again perhaps reaching Ireland via Iona which was amongst 'the vanguard of artistic work at the time (Stevenson 1956, 91). However, the traffic cannot all have been passing in one direction and it seems possible that the interplay of the ornamental repertoires of the two regions may be an equally valid concept.

Although the Ossory crosses are a distinctive group, it is also possible to trace links with other groups of Irish sculpture. The similarities between the layout and ornamental repertoire of the Ossory crosses and Kilree and Killamery may be viewed in the light of their comparative proximity. However, close comparisons have also been suggested between the Ossory crosses and Clonmacnoise IV where, since the metalwork comparisons are not paramount, Clonmacnoise IV is probably the receiver rather than the innovator. This cross also shows links with Kells South, undoubtedly a ninth century monument (see p 91), as does the iconography of Seir Kieran.

Therefore, it seems possible to suggest that the Ossory crosses may be dated to a period at the end of the eighth or the first half of the ninth century.

Furthermore, it does seem possible to trace some kind of relative

chronology amongst the Ossory crosses. Collingwood wrote the following about the development of the Hexham school of sculpture in Northumbria:

'At first, careful, elaborate and naturalistic, a style or school reaches its best results in the hands of some unusually capable craftsman; then his followers try to reproduce the standard results with less labour and thought, gradually debasing current motives until some new influence arises to transform the tradition and renovate the style' (1925, 73-6)

Apart from the fact that the Ossory crosses are characterised by geometric rather than naturalistic ornament, Collingwood's words would also seem to apply to these monuments. The sculptor of Ahenny I was undoubtedly an 'unusually capable craftsman'. He has a very real command of craftsmanship in stone and how to use the influences of metalworking techniques and motives to their best advantage. Ahenny II, though of inferior quality, has so much in common with Ahenny I that it must be of a very similar date. However, on Kilkieran II, Seir Kieran and LoFrha I and II the carving is less accomplished and, more important, the undoubted Vernacular Style metalwork origins of many of the motives have largely been lost. On the other hand comparisons can be made, for example the loss of the sharp chip-carved effect, the infrequency of the spiral ornament and the breakdown in the quality of the plaitwork, with Post Vernacular Style metalwork which may be exemplified by the Kells Crozier (MacDermott 1955). In addition the complex Scriptural iconography on Seir Kieran may be compared with Kells South. These factors would tend to suggest that these monuments are later than the Ahenny crosses but the precise time-span involved is very difficult to gauge.

Kilkieran III, although it is undecorated, may undoubtedly be included with the other Ossory crosses. It seems fairly clear that the monument is not unfinished as the stone has been carefully dressed. It does, however, seem possible that decoration could once have been painted rather than carved, thereby producing a similar, though two-dimensional effect to the ornament on the other monuments. At any rate the survival of this cross is interesting as it shows a parallel tradition to the complex carved crosses of simpler, less ambitious projects.

Mona Incha I is too fragmentary to discuss in detail but from what survives its closest affinities would seem to lie with the rest of the Ossory crosses and therefore it is likely to be of a similar date.

Kilkieran I is problematical and seems to stand slightly apart from the rest of the group. Its fragmentary nature is clearly unhelpful but the style of carving is also problematical. The delicate spiral ornament has its closest comparisons with the stamped spirals on the Moylough Belt Shrine and the ornament of the Clonmacnoise monuments. It is possible

that this lower relief carving could indicate a slightly earlier date than the rest of the Ossory crosses which are characterized by much higher relief.

Ch. V. FOOTNOTES

1. Henry O'Neill (1857, 2) says rather vaguely about the Ahenny capstones:-

On Ahenny II 'The cap has been removed some years ago, and reduced to its present small dimensions, but originally it, doubtless, was a high cone, similar to the North Cross'. Of Ahenny I he says 'The cap was removed some years ago, as had occurred with the cap of the South Cross; but a priest of the locality had the kindness to search out both caps and cause their being restored to their proper place'.

Carrigan (1905, 243) says of Kilkieran II and III:-

'The two latter crosses were broken long ago, but were restored, in an admirable manner, in 1858, by a blind mechanic from Faugheen, named Paddy Lawrence, who had accidentally lost his sight, while engaged in the building of the British House of Parliament'.

2. The dimensions, 30 cm x 30 cm, are the same as the shaft panels on Face A of Bealin but this is probably coincidental.
3. There is a short summary of the various identifications attempted in Sexton 1946, 49-50.
4. Other related panels are cited on p 192.
5. Not ninth century as Flower states. It is impossible to provide the Latin or a translation of this as it has not been published. Flower (1954, 92) gives the following summary of its contents:-

'This prayer begins "Deliver, O Lord, his soul, as Thou has delivered Enoch and Eli from the general death of the world," and contains the following names: "Noah de deluvio, Abraham de Ur Chaldeorum, Job from his tribulations, Isaac from the sacrifice and from his father's hands, Lot from Sodom and its flame, Moses de manu Pharaonis, Daniel from the pit of lions, the Three Children de canino ignis, Susannah from the false testimony, David from the hands of Saul and Goliath, Peter and Paul from prison, Thecla from her tribulations".'

6. Related to this, but not wholly convincing, is Charles Thomas' (1961) tour de force suggesting an Iron Age origin for the animal symbols in Pictish art is dependent upon the continuation of a Celtic style of animal ornament into the Early Medieval Period and it is possible that if correct this could also have influenced the representation of hunting scenes.

Chapter VI. KILREE & KILLAMERY

These two crosses are situated in the South Western part of the ancient Kingdom of Ossory (see p 95) not far from Ahenny and Kilkieran (Map II). In the past their proximity was one of the reasons which led writers (Henry 1940, 105; Roe 1962, 43 ff; Lahert N.D, 33) to group them with the other Ossory monuments but, although they have some aspects in common, the emphases in the ornamental repertoire are completely different so here they are considered separately.

Little is known about the monastery of Killamery but it does have some association with St. Gobban, a saint who is remembered in the Félire Oengusso (Stokes, W. 1905, 250) on December 6th the same day as St. Nicholas whose name the well on the site now bears (Petrie 1878, II, 23-4).

Nothing at all is known of Kilree although the surviving architectural remains are impressive. The siting of the cross in a field approximately fifty meters west of the extant monastic complex led Helen Roe (1962, 49) to suggest it was a termon or boundary monument demarkating an area of sanctuary. However, although this use is recorded for crosses in the source material (see p 40) it cannot be proved here especially as there is no indication of the line of an enclosure or the vallum monasterii; the apparent focus of the surviving buildings may be deceptive.

1) The Form and Layout of the Monuments

The form of the two crosses is, on the whole, comparable. Their dimensions are similar although not identical, Kilree being on a slightly smaller scale. Both monuments seem to have been carefully constructed (Fig. 25). The dimensions of the crosses and the layout of the ornament suggest that, like Ahenny I, there was some overall planning. For example, the width of the horizontal cross arms is approximately half the lengths of the crosshead and shaft excluding the butt and these measurements are almost identical on both crosses. Many of the measurements show a recurrent use of lengths which are multiples of 5cm. This is also found on the ornamental layouts where 5cm. and 2.5cm. unit measures seem to be frequently employed. This suggests a link with Ahenny I (see p100) where

Fig 25.2

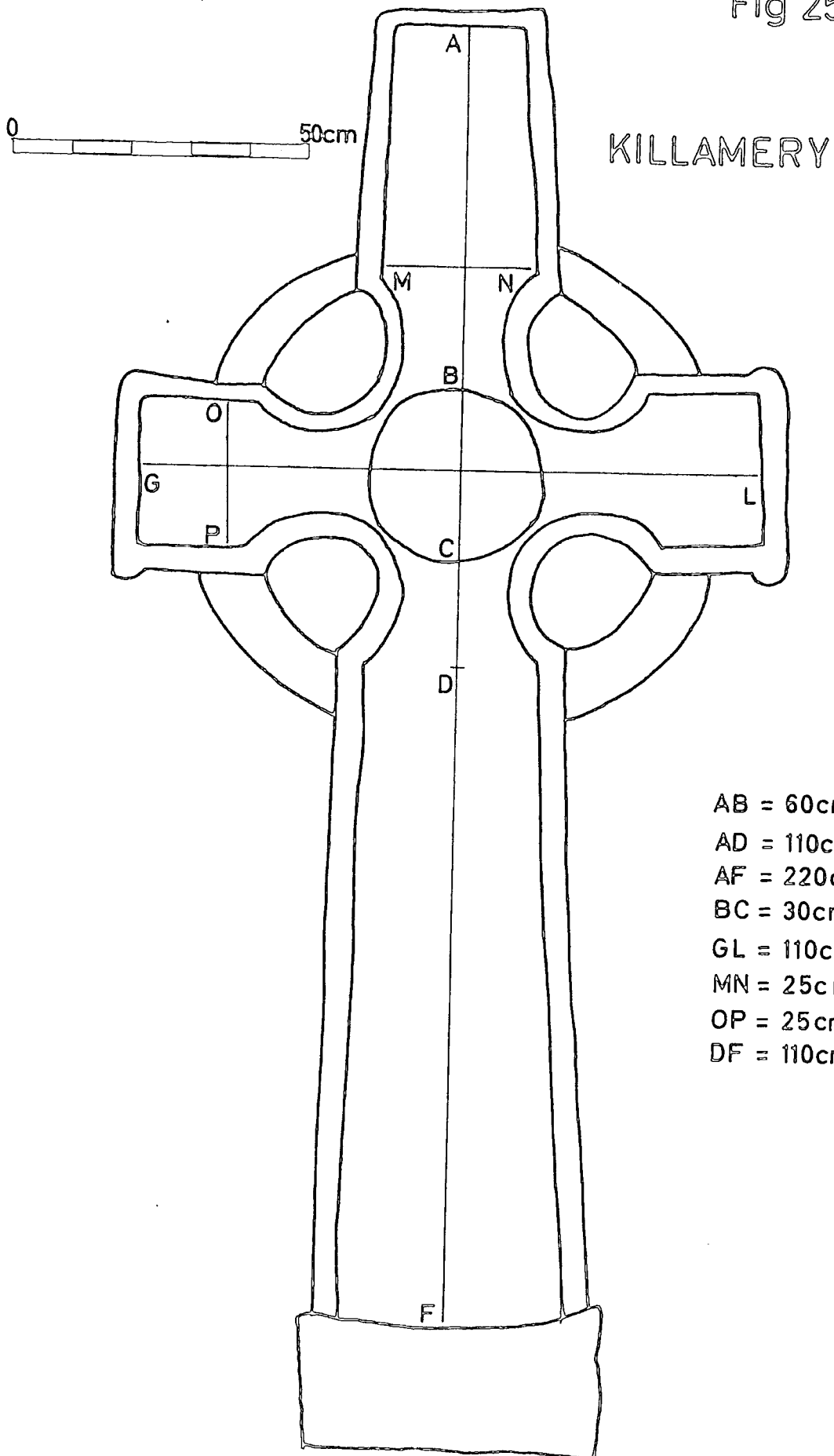

- AB = 60cm
- AD = 110cm
- AF = 220cm
- BC = 30cm
- GL = 110cm
- MN = 25cm
- OP = 25cm
- DF = 110cm

DIMENSIONS OF KILREE AND KILLAMERY

the 5cm. and 2.5 cm. units of measurement are also significant.

In their form and layout Killamery and Kilree have aspects in common with both the Clonmacnoise and the Ossory crosses. They both have the same form of crosshead, Type I, which may be compared with Bealin and Clonmacnoise IV (see p 47), although in the case of Kilree its large size in comparison with the dimensions of the shaft is closer to the Ossory crosses. Both also have a greatly elongated upper cross arm which may be paralleled on both the Ossory monuments and on St. Martin's Cross, Iona (Allen & Anderson 1903, III, Fig. 397). The placement of the domed bosses on the crosshead of Kilree Face A, in general may be compared with Clonmacnoise IV and the Ossory monuments but the placement of the boss in the centre inside a large roundel is paralleled on Bealin where the layout of the crosshead on Face A is almost identical although the actual bosses are in very much lower relief. On Killamery the bosses are of less importance being confined to one in the centre of the crosshead on both faces. The crenellated roof shaped capstone on Killamery is almost identical with that on Clonmacnoise IV. Without doubt there was originally also a capstone on Kilree because of the tenon on the top crossarm but unfortunately its form is unknown.

Other aspects of the layout of Killamery may also be compared with Clonmacnoise IV. The position of the Crucifixion scene and the dimensions of the shaft are both similar and the division of the shaft on Face A into two large rectangular panels separated by incised lines is analogous with Clonmacnoise IV face C. However, the vertical division of the narrow faces of the shafts into three recessed panels on both Killamery and Kilree may be compared with the Ossory monuments (see p 97).

The form of the perimeter mouldings is one aspect which clearly divorces Kilree and Killamery from the Ossory monuments where the high relief perimeter rope mouldings form one of the characteristic features of the group (see p 97). Kilree, however, has perimeter roll mouldings in comparatively low relief which have more in common with Bealin while those on Killamery, although they are in higher relief and hatched with herring bone ornament, have little of the bulk of the Ossory monuments and again the closest analogues are with Clonmacnoise IV (see p49).

Some features in Killamery are also paralleled on the 'Scripture' crosses. The placing of the inscription on the butt and the emphasis on the mouldings at the end of the horizontal crossarms on the broad faces (see p203) are both found on many of the 'Scripture' crosses exemplified by Durrow I and Clonmacnoise V although the latter is also to be found on Kilkieran II.





2) The Ornament

Like the Ossory monuments abstract ornament dominates these two crosses and its placement is subordinate to the actual cross form. But on Kilree and Killamery the most characteristic ornament is fret and step patterns prominently placed which cover large areas of both monuments. By comparison the sculptors of the Ossory and Clonmacnoise groups make little use of this kind of ornament (see pp78,112).

a) Fret Patterns and Related Ornament

The repertoire of fret ornament on Kilree and Killamery is very similar. It is used to decorate the large rectangular shaft panels, Kilree C 9 and C 10 and Killamery A 11 and A 12, some of the panels on the narrow faces of the shaft, Kilree B 5 and D 7, and a small square panel on the end of the horizontal cross arm, Kilree B 3. There are a number of other very simple patterns derived from fret ornament on the bases of both monuments, Kilree C 12 and D 9 and Killamery D 11.



The more complex patterns seem to have been constructed on diagonal grids. Two unit measures seem to have been employed. The first, since it is based on multiples of 2.5cm, both 5 and 7.5 cm being represented, may be compared with the dimensions of the crosses and would also seem to suggest links with the Ahenny monuments (see pp100,105). On Kilree C 10 the unit measure seems to be different, 9cm.

Two different types of ornament are represented on the Broad face shaft panels. The first, on Kilree C 10, is a simple pattern of interlocking  and  elements. The pattern on Killamery A 11 is very similar except only  elements are used. This type of pattern may be compared with Ahenny I A 3 (see p112) but the style of carving is completely different. Instead of outlining each element in relief they are deeply incised, the surface of the panel remaining flat, more in the manner of the fret pattern on Gallen Priory I (see p266) or the background pattern on the crosshead of Clonmacnoise IV C 1 (see p 80). The second pattern type, which uses interlocking  elements, is difficult to see as it is lightly incised, a technique which contrasts well with the more deeply incised fret patterns on other panels. Identical versions are found on Kilree C 9 and Killamery A 12 and the pattern on Kilree B 3 is also similar. Patterns of this type are comparatively rare elsewhere in Ireland although there are parallels on Graiguenamanagh I A 9 and

Castledermot North (see p196). However, the closest comparisons for both these types are to be found in Pictland where the fret patterns have a far greater variety and complexity (Allen and Anderson 1903, III, 308 ff) than elsewhere in the British Isles (see p 14). Fret patterns of the first type are found on the early Class II slabs but, as Isobel Henderson (1978, 51) has remarked, they are also popular on many of the developed Class II and III monuments where large areas are decorated with simple repetitive patterns of interlocking elements very like the Kilree and Killamery designs. The large panel of interlocking  elements in low relief on Rosemarkie I provides a good example (Allen and Anderson 1903, III, Fig. 60A). The second type are commonly used in Pictland to decorate the central roundels on horizontal cross arms of the early Class II slabs, Aberlemno II for example (op cit, Fig. 227A). On the more developed slabs this type of ornament is found on the shaft, as at Nigg, or adjacent to it as an Aberlemno III (op cit, Figs. 72, 228A). Rosemarkie II is the only Pictish example where the two types are used concurrently (op cit, Fig. 83). This fragment has three large panels decorated with fret patterns.

In manuscripts early examples of fret patterns used in this way may be seen in the Lindisfarne Gospels (Nordenfalk 1977, Pl. 15). They are used to a much greater extent in the Book of Kells (Henry 1974, 206, e.g. f3R, f4V) and in the late ninth century Book of MacDurnan (Lambeth Palace Lib.) (Henry 1967, 102-5, Pl. I).

Kilree D 7, a long narrow rectangular panel, has the only other example of proper fret patterns using interlocking elements on these two crosses. There are no parallels for the upper pattern but the lower is also found on Clonmacnoise IV D 6.

The rest of the fret patterns on Kilree, B 5, C 12 and D 9 and Killamery D 10 are much less accomplished and no attempt has been made to interlock the pattern elements. On Kilree B 5 the  elements have simply been placed one above the other. They are outlined in relief in a similar way to the fret patterns on the Ossory crosses (see p 112). The other patterns are even cruder, the elements being clumsily adapted to fill large areas of the base, almost the manner of enamelled cells. The recessed  shapes on Killamery D 11 are decorated with a plaitwork mesh. Examples of recessed areas decorated in a similar way are also found in Pictland on Rosemarkie I (Henderson 1978, 50).

b) Step Patterns and Related Ornament

Step and chequer board patterns are also used extensively on these two monuments. These patterns are used to decorate large areas of the base, Kilree B 6, D 8, Killamery A 15 iii, B 8 and C 8, and the upper cross arm, Kilree C 1 and Killamery A 1.

These patterns must have been constructed on square grids and this may be illustrated by Killamery B 8. Although the pattern is badly weathered, it is possible to trace fragmentary incised lines marking out a square grid which has become an integral part of the pattern. The basic motif, a double step pattern, has been divided into squares, with the exception of the cruciform void in the centre, using incised lines. In addition the step patterns on Kilree C 1 and Killamery A 1 are in sufficiently good condition to be able to trace a unit measure which clearly ties in with the constructional grids employed for the fret patterns.

The step patterns are very simple and repetitive but the potential monotony is relieved by the use of a variety of scales and differences in detail and style of cutting. Firstly, there are a number of horizontal rows of large step units on the bases of the two crosses, Kilree D 8 and Killamery B 8 and C 8. The relatively simple pattern on Kilree D 8 with the cruciform cut out shapes in the centre of each unit may be compared with Mona Incha I A (see p 113). Killamery C 8 is very similar except that the cruciform cut out shapes are more delicate with expanded terminals. Killamery B 8 is, however, more complex because of the incised grid and the interlace mesh carved in the spaces round the perimeter.

The step patterns on the upper cross arms of both monuments, Kilree C 1 and Killamery A 1, are on a much smaller scale. There is a similar pattern on Killamery C 9. The panel on Kilree A 3 is severely weathered but it would also seem to be a small scale pattern, this time using squares or 'L' shapes rather than steps.

Thirdly, there are small areas of chequer board pattern which make up cruciform motives on Kilree B 6 and Killamery A 15 iii. The latter is made more complex by the addition of spiral ornament on the cruciform shapes which may be compared with Kilkieran I a A 2.

Therefore step patterns are prolific on both Kilree and Killamery. However, they are much less common on other Irish sculpture since they are restricted to isolated instances on Bealin B 2, Clonmacnoise II B I,

Mona Incha I A and Kilkieran I a A 2 (see pp79, 114). Chequer board and other related patterns are slightly more common elsewhere being found on Ahenny I A 3, C 4 and C 5, Lorrha I C 6 and Leggettsrath I D (see pp 113, 114, 269).

As has already been suggested (see pp 15, 78) the origins of these patterns undoubtedly lie in metalworking techniques but large areas of such ornament are unusual since the motif is usually used to decorate small enamel plaques or glass studs. There are only two examples of Vernacular Style metalwork objects where step patterns are extensively used, the Emly Shrine (see p78) and the Copenhagen Shrine (see pl14; Fig. 21). The large rectangular panels on Kilree and Killamery would seem to be a development of this sort of design translated into stone.

c) Zoomorphic Ornament

No other types of ornament are extensively used on these crosses. Indeed, on Kilree the only example of zoomorphic ornament is a bird's head terminal on A 1. However, the one zoomorphic pattern on Killamery C 1 is amongst the most dramatic representations in the entire repertoire of Hiberno-Saxon art. The actual motives, conceived on a large scale, are relatively simple but the swinging rhythm of the pattern, which has been planned to fill a very uneven sculptural field, and the tension caused by the feeling of frozen action, acknowledges a designer of the highest calibre.

Dragonesque Motives Biting dragonesque heads emerging from spirals or less frequently from interlace are a recurrent theme in Hiberno-Saxon art. The closest parallels for the Killamery motif are to be found in Vernacular Style metalwork, particularly with the group of objects cast in high plastic relief (see Appendix 2). The finest of these are the St. Germain plaques (Henry 1938, 65 ff; Hunt 1955-6; Mahr 1932, Pls. 25, 26) and the now fragmentary Gausel mounts (Bakka 1965, 40). On these there are a number of dragonesque heads which emerge from hairspring spirals to clasp human or serpentine heads in their gaping jaws (Fig. 26). Both the motion implied by the design and the actual features of the dragons, with their almond shaped eyes, spiralled snouts, jagged teeth and hatched necks, have much in common with the Killamery motif. There are similar, more serpentine

beasts with gaping jaws and hatched bodies emerging from spirals on the Romfohjellen and Copenhagen Mounts (Petersen 1940, 61, Fig. 67; Wilson 1955, 167-8) (Fig. 13). Biting dragonesque heads are also found on other types of metalwork. The Ekerø crozier (Holmquist 1955) (see p114) (Fig. 26), made in the actual form of a dragonesque head with gaping jaws, carried out in a mixture of chip-carved and enamelled techniques, has the same powerful vitality as the Killamery motif and again the facial features are very similar. There are other examples of dragons on the rim of the Tara brooch (Henry 1965, Pl. 42), on the Tessem and Halsan Mounts (Bakka 1963, 50; Petersen 1940, 68) (Fig. 26) and on the gable finials of the Emly Shrine (Mahr 1932, Pl. 17). Dragonesque motives are retained on a post Vernacular Style pseudo penannular brooch which was actually found at Killamery (MacDermott 1955, 82; De Paor, M. 1977, 147). On the back of this are two dragons with almond shaped eyes, curled lips and gaping jaws which are surprisingly close to their sculptural counterparts (Fig. 26). On this brooch there are also quadrupeds with similar features and hatched bodies.

There are further parallels for the Killamery dragons in sculpture but on these the vitality of the motif has been lost to a greater or lesser extent. The closest comparison may be made with a small but unusual cross slab from Gallen Priory (Henry 1965, Pl. 65) where the miniature cross head is decorated with a lively dragonesque motif. Snakes and beasts with long snouts or beaks emerge from a central spiral and snap at human face masks. There are more abstract dragons on the crosshead of Ahenny II A 2 and snake-like creatures on Kilkieran I A 3 (see p114). Similar motives are also found on other Irish crosses. On Moone serpents are combined with spirals on the crosshead and with lions on a base panel (Henry 1965, Pl. 68; 1964, Pl. 15). On Termonfechin dragonesque heads with gaping jaws are used as 'C' scroll terminals on one of the shaft panels (Henry 1933, Pl. 90).

There are a variety of other dragonesque motives in Hiberno-Saxon art which may be related in some way to those on Killamery. Dragonesque motives, frequently grasping human heads in their jaws, are also popular in Pictish sculpture (see p115). There are also dragons with feline characteristics in the Book of Kells (Henry 1974, 206-7, Pl. 49). In addition a large number of more serpentine

Fig 26.2

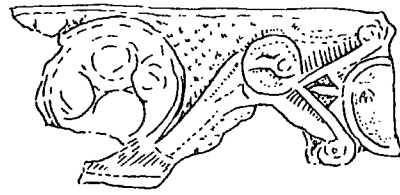
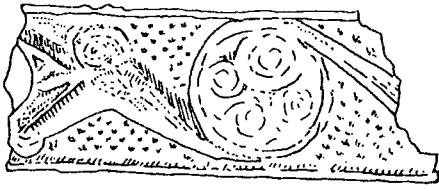

1

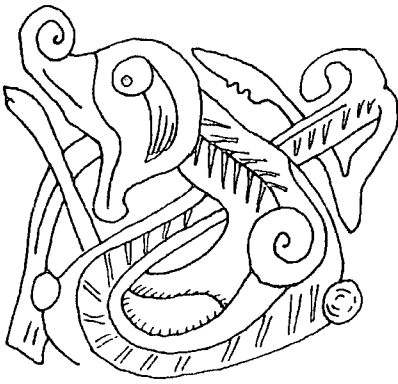

2

3

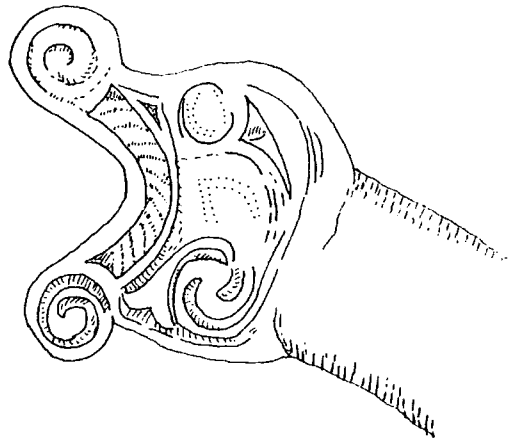

- 1 HALSAN MOUNT
- 2 TESSEM MOUNT
- 3 KILLAMERY BROOCH (Detail)

representations (see p 64) may probably be included as in many cases the beast types merge into each other as is indicated by the creatures on the Romfohjellen Mount (Petersen 1940, Fig. 67).

Françoise Henry (1933, 78-80) has rightly said that the ultimate origins of both dragons and serpents probably lie in the Pagan Celtic past. The importance of the serpent in Celtic religion is well attested both in literature and iconography. The struggle between man and serpent is a recurrent theme (Ross 1967, 344-8) but the surviving evidence suggests the dragon was more important in Wales than Ireland. Ann Ross is of the opinion that the Christian church was intolerant of such cults but this does not explain the continuing popularity of both serpents and dragons, frequently shown in combat or clasping severed heads in their jaws, in an overtly Christian context. The answer may be that either these beasts became a purely decorative motif or they were furnished with some sort of Christian symbolism which would make them acceptable to the Church. Dragons were associated with the Devil in the minds of the Early Christian Fathers (Cadbrol and Leclercq 1907-52, Vol. 4.2, 1537-8) and serpents have similar connotations. The Devil took on the form of a serpent in the Garden of Eden and God cursed it after the Fall. Christ fulfills the prophecy of bruising the serpent's head when he is crucified and in Early Christian iconography the serpent is sometimes shown writhing round the bottom of the cross or Christ is shown trampling on it (op cit, Vol. 15.1, 1353-4; Schiller 1972, 112-3). In addition, it is also possible that they may form a further stratum of fantastic beasts as described by Isidore of Seville (Brehaut 1964, 227-8) or in the Physiologus (White 1954, 15) (see p162).

The Displayed Beast On the upper cross arm of Killamery C 1 is a spreadeagled quadruped with goggle-eyes, gaping jaws and jagged teeth. The motif is unusual since the body and eyes are shown face on while the jaws are in profile (Fig. 27). The facial features are clearly a variation of the dragonesque image already discussed but the body may be associated with a different Vernacular Style metalwork motif. This is not frequently employed but again the closest parallels are with the group of objects cast in high plastic relief. The crouching frog-like creature on the Steeple Bumpstead boss (Fig. 27) (O'Dell et al 1959, 263) provide the best comparison for the Killamery motif. They

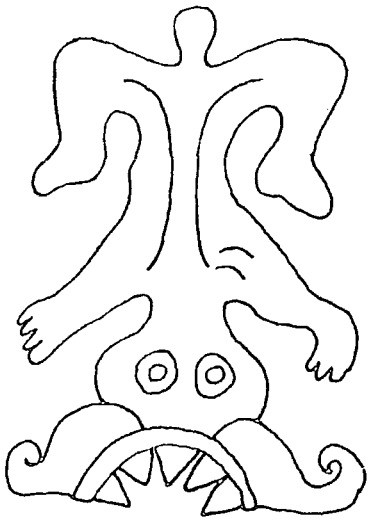

1

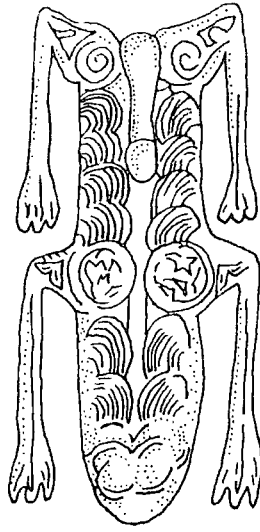

2

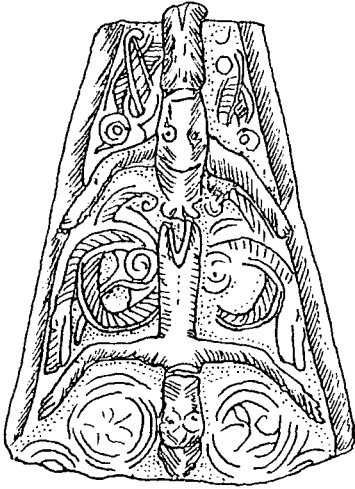

3

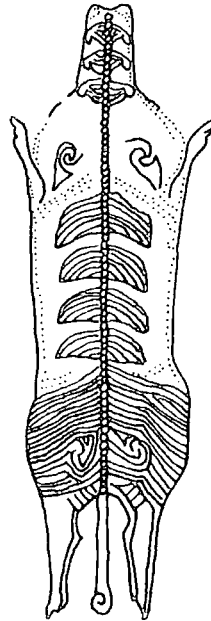

4

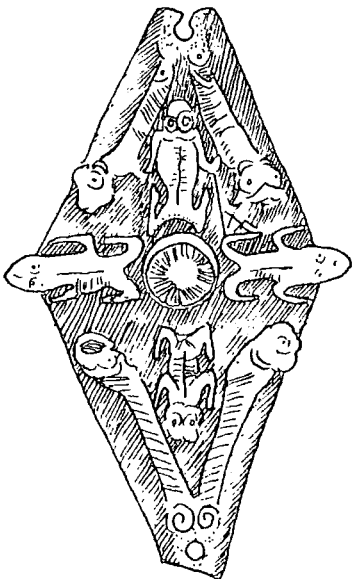

5

Fig 27
 DISPLAYED
 BEASTS

1 KILLAMERY C1

2 STEEPLE BUMPSTEAD
 BOSS

3 VATNE MOUNT

4 ST NINNIAN'S ISLE
 HANGING BOWL

5 MELDY MOUNT

both have their front legs lying close against their flanks, a short tail, a delineated backbone and large goggle-eyes. The four spread-eagled beasts emanating from the central amber inlay on the bronze mount from Meløy in Norway are almost identical (Fig. 27) (Mahr 1932, Pl. 32.3a; Petersen 1940, 75-6, Fig. 86) and the quadrupeds on the Vatne mount, also cast in high relief, are very similar except that their long snouted heads are turned to face their tails and only their front legs are splayed (Fig. 27) (op cit, 66). There is a further, less significant parallel in the form of the displayed boars on the St. Ninian's Isle Hanging bowl, currently dated to the late seventh century (O'Dell et al 1959, 263, Small et al 1973, 136) (Fig. 27). There are also examples of displayed beasts in the Anglo-Saxon context (Wilson 1964, 11) but their features do not resemble the Killamery motif.

d) Interlace

This is not extensively used on either Kilree or Killamery. Where it is employed, apart from the main shaft panel on Killamery C 2, it is not prominently placed, tending to be confined to the long shaft panels of the narrow faces, Kilree B 4, B 5, D 7 and Killamery B 1, B 6, D 1, D 7 and D 8. It is also used to decorate the roundels on Kilree A 1 and C 2 and Killamery B 7 and small base panels on Killamery A 15. There are traces of plaitwork on the wheelarcs of both monuments.

Like the Ossory crosses (see p104) the repertoire of patterns is severely limited. Apart from the marigold pattern on Killamery C 2 it is confined to two, four and six strand plaitwork and combinations of Simple E and F elements.

Most of the patterns are competently carried out and have an elegant appearance. This is achieved partly by the style of carving, which is very flat, the broad bands on many of the patterns seeming almost to flow over and under each other, and partly because of the obvious care with which they have been constructed. It seems likely that both square and diagonal grids were used. Indeed, fragmentary indications of what is likely to have been the original diagonal grid are still visible on Kilree B 4. The pattern, six strand plaitwork, is in an excellent state of preservation and it is still possible to see fragmentary lines marked along the centres of the

KILREE B4

Fig 28

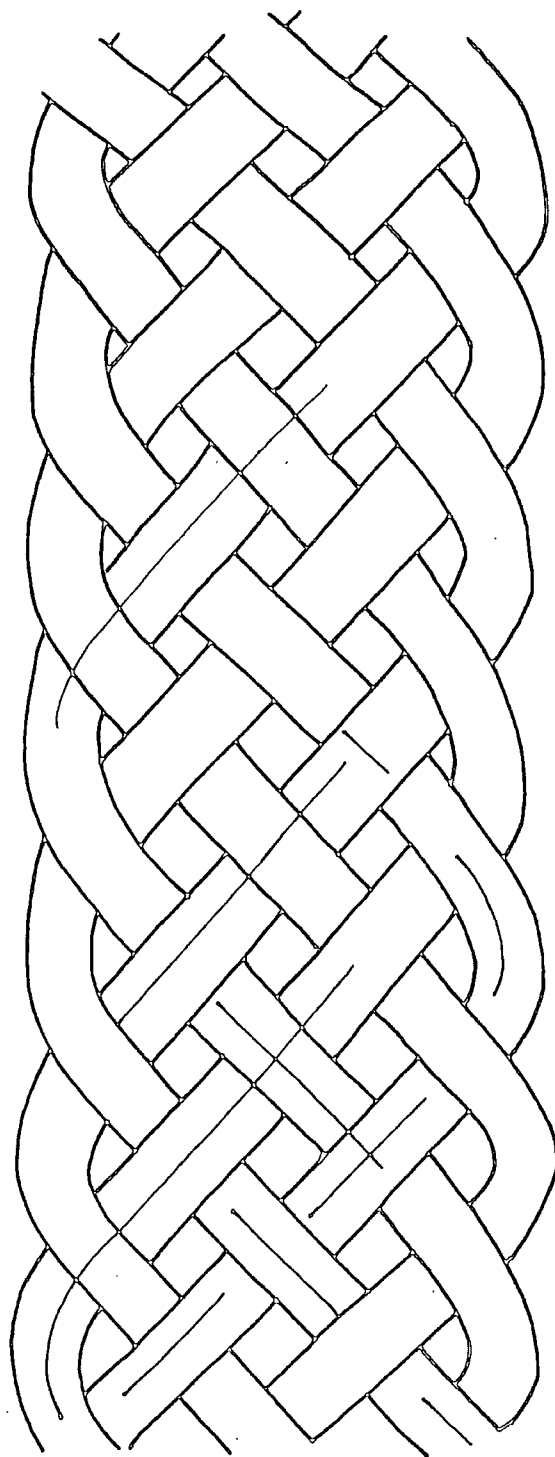

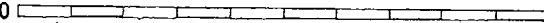
0  10cm

strands in the manner of a median line (Fig. 28). However, on close examination, it can be seen that these lines, instead of following under and over each other like the strands, continue thus indicating the crossing points on a diagonal grid. The unit measure used, 2.5 cm, may be compared with both the fret and step ornament and the dimensions of the monument as a whole. There are not a great number of interlace patterns and so it is difficult to tell whether consistent unit measures are used. However, Killamery A 15 and B 5 both show indications of having been constructed on a 5cm grid.

The marigold pattern on Killamery C 2 occupies the whole length of the shaft. This is unusual as the only parallel in Ireland for the shaft of a cross being decorated with a single run of ornament is Bealin C 4 (see p 65). This pattern has also been carefully planned. There are still traces of a vertical line down the centre of the panel and it may be seen that the size of each marigold unit, which would have been constructed with the aid of a compass, has been adapted to allow for the taper of the shaft. The flatness of the carving is again very evident since neither the marigold petals nor the fillers are modeled in any way. The background only has been cut away and the details picked out with incised lines.

The marigold is an unusual motif on the Irish free standing crosses although versions of it are more common on grave slabs (Lionard 1960-1, Fig. 9). The only other examples on the crosses are found on Kilkieran II B 9 (see p109) and the crosshead of Templeneiry I A. The only close parallel for Killamery C 2 is provided by a rather puzzling shaft from Yarm, Co. Cleveland (Greenwell 1899, 112-5; Adcock 1974, 141, Pl. 44) which is hard to place within the Northumbrian context. Here an elegant four petalled marigold is combined with triquetra knots used as fillers very much in the manner of Killamery C 2. There are other examples of four petal marigolds on a fine, probably early, pillar from Skye (Henry 1940, 55, 60, Pl. 18C), where the motif is incised within a square flabellum, and on a grave slab from Inis Cealtra (Lionard 1960-1, Fig. 9.9). On metalwork it is found, with the addition of a ring on round mounts from Fingstad and Skróppa in Norway (Petersen 1940, 16, Fig. 5; Bakka 1965, 55-6, Fig. 62). Four petalled marigolds with the addition of rings (RA Nos. 771, 2 and 3), set either singly or in runs, are also found on Anglo-Scandinavian sculpture in Britain

(Bailey 1974, 92-6). In a broader context the marigold with four, five, six or more petals is a popular and long run motif and therefore is of little help in establishing a chronology. Compass drawn ornament of this type is frequently found in western art from the Late Roman Period onwards (Hoseloff 1958, 78-80; Hencken 1935-7, 197; Henry 1965, 130; Bailey 1974, 92-6) and, with the advent of Christianity the marigold took on a Christian meaning and is associated with the ~~Xp~~ cross of arcs in the decoration of flabella. (Lionard 1961, 111).

The patterns on the narrow face of the shafts on both crosses are severely restricted by the width of the panel. The result is that, like the narrow faces on Clonmacnoise II and III (see p 56), there is only room for interlace patterns using a maximum of six strands. Sometimes the pattern runs the whole length of the shaft as on Killamery D 8, where a twist and ring pattern, a variation of Simple F, is used. In Ireland this pattern is paralleled in a similar position on Castledermot North (see p196) and the Carndonagh Slab (see p 25) (Henry 1933, Pl. 12). It is also found on the Ballinderry gaming board (Henry 1967, Pl. 15). It is difficult to tell whether this is significant but elsewhere in the British Isles this pattern seems to be used widely in fairly late contexts (RA No. 574). It is found on a number of the later Pictish monuments, Cossins, Forres and Farr, and is also frequently used in tenth century Scandinavian sculpture in the Isle of Man (Kermode 1907, e.g. Pls. 74, 75, 84, 85, 86) and in the North of England (Hencken 1935-7, 177-8; Brønsted 1924, 227; Bailey 1980, Fig. 7A).

On Killamery B 1 and D 1 continuous lengths of two strand twist with a broad flat strand are used but on Kilree D 7 the sculptor has broken the monotony of a four strand plait by the introduction of glides and on Kilree B 4 and B 5 changing patterns are used. Changing patterns are also a feature of the Clonmacnoise monuments (see p57).

At the centre of the crosshead on Kilree A 1 and C 2 is a large roundel. Kilree C 2 in particular may be compared with a similar roundel in an identical position on Bealin A 1 (see p53). In each case the outer border pattern is composed of Simple F elements, although the centre of Kilree C 2 is raised into a boss whereas Bealin A 1 is flat. There is a further parallel on the Crucifixion

plaque from the Calf of Man (Kermode 1907, Pl. 50). The Kilree C 2 pattern appears somewhat muddled. This is chiefly because the sculptor used the broad, flat strand 3 cm wide and a closely set pattern characteristic of these crosses which has been difficult to adapt to the shape of the roundel. The strand width on Kilree A 1 is less, 1.5 cm with the result that the pattern appears much more ordered. It may be significant that these strand widths are also consistently used on Bealin.

Roundels of this type, either completely flat, or with bosses, are clearly derived from Vernacular Style metalwork where such roundels are common. Both Petersen's (1940) and Mahr's (1932) corpora have many examples which are now detached from the objects they once adorned but it seems that they were particularly popular on House Shrines, for example that from Lough Erne (op cit Pl. 9).

There is a further small flat interlace roundel on the butt of Killamery B 7 which is an unusual position for such a motif.

The groupings of Simple E elements on Killamery A 15 may be compared with those on Ullard A 15 (see pl96).

e) Spirals

Like the interlace, spiral ornament is not prolific but a number of different kinds of pattern are employed. Firstly, hair spring spirals are combined with bosses on the crosshead of Kilree A 1 and 'nail head' bosses are introduced into the spiral pattern on Killamery A 14. Secondly, on Kilree A 7, there is a kind of slashed pattern which is clearly related to spiral ornament. Thirdly, long spiral panels carved in low, flat relief are used on the narrow faces of the shaft end wheel arcs on Kilree B.5 and Killamery B 5. In addition spirals are introduced into the chequer pattern on Killamery A 15 (see pl37) and a spiral has been incised on a small flat roundel at the centre of the crosshead on Killamery A 3. The latter is paralleled on a Class III monument from Farr in Northern Pictland (Allen and Anderson 1903, III, Fig. 51).

The use of hair-spring spirals is rare in the sculptural medium. The only possible comparison may be made with the zoomorphic motif, likewise incorporating a bird's head, on Clonmacnoise I D 2 (see p 65). Otherwise the combination of bosses on the crosshead with a background of spiral ornament has already been noted on Ahenny I A 1

and Clonmacnoise IV A 1 (see pp 78, 100) but this pattern is on a much larger scale and much bolder. However its closest affinities are also with metalwork motives. Tight hair-spring spirals paired with bosses are an important part of the ornament of the St Germain plaques (Mahr 1932, Pls. 25, 26). Examples are also found on the Romfohjellen and Komnes mounts (Peterson 1940, Figs. 67, 12). In manuscript illumination hair-spring spirals may be seen used in an early context on the *initium* page in the Book of Durrow (Nordenfalk 1977, Pl. 5).

On Killamery A 14 'nail head' bosses, similar in shape to those used on Ahenny I and II (see p 98) are used with a pattern of 'S' scrolls with feathery leaf shaped expansions. The combination of bosses with spiral ornament is not found on the Ossory crosses but is a feature of Clonmacnoise IV (see p 76) and the spiral patterns on Bealin, Banagher and Clonmacnoise II provide the closest analogies for the leaf shaped expansions (see p 76).

The spaces between the spirals on the upper cross arm of Kilree A 1 are slashed with tiny triangular shapes. This delicate network gives a clue to the original form of the pattern on Kilree A 7 where all that can now be traced on the weathered surface are groupings of similar triangular shapes. The unpierced areas between form five circles which were once probably joined to make a spiral pattern. This seems to be a simplified version of the practice of slashing spiral scroll expansions derived from chip-carving which is one of the characteristic features of the Ossory crosses and Ahenny I in particular (see p 101).

Ahenny I B 5 and D 5 also provide the closest comparison for the long panels of interlocking 'S' scrolls on Kilree B 5 and C 5 (see p 102). However the style of carving is different since the Killamery spirals are broad flat bands rather than the sharp cut technique found on Ahenny I. There are similar simple border patterns on the narrow faces of Aberlemno III and the front of Cossins (Allen and Anderson 1903, III, 215, Fig. 230A).

3) Figural Panels

Compared with the abstract designs, figural panels play much less part in the decoration of these two crosses. This is in line

with the Clonmacnoise and Ossory monuments but on Killamery and Kilree the positioning of the figural scenes seems more prominent. They are placed on the horizontal cross arms on both Kilree C 3 and 4 and Killamery A 4 and 5. There are other panels on the top cross arm, Killamery A 2, and at the top of the shaft on Kilree A 6 and Killamery A 10. Further panels are less centrally located on the narrow faces of the crosshead on Kilree D 3 - 6 and Killamery B 3 and 4 and D 3 - 6. However, despite their position, these figural panels do not stand out. They are all executed on a very small scale and the impression given is that the sculptors have sought to introduce the iconography onto the crosshead without displacing the abstract ornament. The results of this may be seen clearly on Kilree A 6, where the figural scene has been squashed into the small space between the roundel at the centre of the crosshead and the boss at the top of the shaft. This, combined with the use of very low relief, could indicate an unfamiliarity with the use of figural representations and how to carve them.

A combination of low relief and weathering mean that much of the carving on these panels has been lost and therefore many of the scenes are difficult to identify or discuss in detail. However, from the surviving fragments it may be seen that the range of iconography represented, Scriptural episodes, religious processions, and hunting scenes, with the addition of fantastic beasts, is similar to Ahenny I and II (see p116).

a) Scriptural Iconography

Representations of the Crucifixion on Killamery A 10 and Daniel in the Lions' Den on Kilree A 6 may be securely identified as may two versions of Jacob wrestling with the Angel on Kilree D 5 and Killamery D 3. The identification of scenes from the David Cycle on Kilree D 3 and Killamery A 2 and D 4 must remain somewhat more speculative.

The Crucifixion The Crucifixion on Killamery A 10 may be closely compared with Clonmacnoise IV A 2 and Kells South (see p 86). It is placed in an identical position at the top of the shaft. The style of carving, in very low flat relief, and many of the stylistic features,

Christ's large head, puny arms and tunic, are also paralleled on Clonmacnoise IV A 2. By this analogy it seems likely that the spear and sponge bearers would originally have been present on Killamery A 10 as well. However the sculptors were not relying on exactly the same model since the figures placed either side of Christ's head seem to be angels and the circular object they hold a wreath. Angels are frequently found in this position on sculpture, for example the Barrow Valley crosses (see p 189) and many of the 'Scripture' Crosses (see p 212) but the introduction of a wreath seems to be without parallel. Angels holding wreaths have their ultimate origins as winged victories on consular diptychs. One example is found on the leaf of a diptych of Flavius Anastasius dated 517 (Beckwith 1961, Pl. 42). They are very early transferred into a Christian context where they indicate Christ's victory over death (Schiller 1972, 106) and thereafter occur very widely. For example two flying angels holding a wreath with a chi-rho are shown on the Sarigüzel Sarcophagus made in the second half of the fourth century in Constantinople (Beckwith 1961, Pls. 23-6) and on a sixth century Byzantine ivory which keeps the form of a consular diptych showing Christ enthroned there are two angels holding a wreath with a cross who fly above His head. The only parallel for a wreath held aloft elsewhere in Irish sculpture is the Evangelist figure of St Matthew holding up a wreath with the Agnus Dei above the head of Christ in Glory on Kells South (Roe 1966, Pl. IV).

Daniel in the Lions' Den The scene on Kilree A 6 is almost without doubt Daniel in the Lions' Den (Roe 1962, 51). The central figure appears to be crouched or seated between two animals which Françoise Henry identified as horses. This led to the belief that the Celtic horse goddess Epona (Henry 1933, 122, Fig. 90; Ross 1967, 323) was being represented. However, the accompanying beasts are not horses; they have much more the appearance of lions and for this reason Daniel seems much more likely. It is placed in the same position as the Killamery Crucifixion and this is interesting because, as well as being associated with the Help of God cycle (see p121) the story of Daniel in the Lions' Den (Daniel VI, 17-25) may also be seen as a prefiguration of the Resurrection and various quotes from Daniel are also found in St Matthew's Gospel in the chapters dealing with the

Passion Cycle (Lattey 1948, XXXVI), for example when Christ speaks to Caiaphas (St Matthew XXVI, 64). It is interesting to note that on both the South and Market Crosses, Kells, Daniel and the Crucifixion are placed in identical positions on opposite broad faces of the cross. In such a position it seems likely that the Daniel scene symbolises the Resurrection, thereby counteracting the Crucifixion on the other face. Daniel is placed in a similar position at the top of the shaft on Kells and St Martin's Cross, Iona (Allen and Anderson 1903, III, Figs. 408, 397A) but on these there is no Crucifixion.

The lions with their curled up tails on Kells South are similar to those on Kilree but the figure of Daniel on Kilree is much squatter. This could be because the scene is squashed but it could also be that he is actually sitting. The closest comparison is provided by St Vigean's XIV, a recumbent monument, where the small figure of Daniel with raised arms is squashed, again possibly sitting, into a similarly narrow space (op cit, Fig. 285A). There are further parallels on Inchinane III and Newton Woods (op cit, Figs 478A, 481). From France there is also a belt plaque showing Daniel seated amongst seven lions from Daillens in the Vaud (Cadbrol and Leclercq 1907-53, Vol. 4.1, Col. 224).

On a more general note Daniel in the Lions' Den is a popular episode frequently illustrated on Irish monumental sculpture with a number of variations (Henry 1967, 176), being particularly popular on the Kells and Ulster crosses (op cit, 153). It became a popular feature of Early Christian art and at an early date is found in the catacombs (Gough 1973, Fig. 35) and on sarcophagi (e.g. Le Blant 1886, Pls. XXV-3, XXIV-2). There is an interesting seventh century example from the abbey at Charenton-an-cher, founded in 620 under the rule of Columbanus where Daniel is shown clothed rather than naked as on the more classical examples and with a lion advancing towards him from either side rather than seated at his feet (op cit 55-6, Pl. XV). A clothed Daniel with two lions, one either side of him and licking his feet is frequently found on the Burgundian buckles (Grosset 1953, 151-2; Lasko 1971, Fig. 77) and there is a similar representation on the late seventh century capitals at San Pedro de la Nave in Spain (Werkmeister 1962-3, 168). Charles Grosset has suggested (1953, 153) the popularity of the theme in these barbarian societies may be due to the importance of the idea of man's struggle

against beasts. This idea is also recurrent in Celtic literature (e.g. Ross 1967, 346-7) and it seems possible that these sort of representations may provide an ultimate source for those in Ireland.

Jacob and the Angel This scene is represented on Kilree D 5 and Killamery D 3. It may be paralleled on the Market Cross Kells (Roe 1966, Pl. XII), Castledermot South, Clonmacnoise V B 14 and Durrow I D 10 (see p233). This popularity is surprising considering the apparent dearth of comparative material. There are two other possible insular parallels, a crude example from Eilean Mor in Argyle (Allen and Anderson 1903, III, Fig. 396A) and there is possibly a further version from Chester-le-Street, Co Durham (Pers. Comm., Rosemary Cramp). The only possible clue to the ultimate origins of the scene is provided by a single representation on the late fourth century ivory casket from Brescia which includes several rare iconographic episodes (Volbach 1961, 328, Pl. 88; Beckwith 1979, 50, Pl. 35). Porter (1929, 85ff; 1931, 124-8), who was the first to recognise this scene in Ireland, was forced to cite nearly all Romanesque and Gothic parallels for it.

The David Cycle Three possible episodes from this cycle may be tentatively identified: David breaking the jaws of the lion, the fallen Goliath and David and Goliath fighting.

David Breaking the Jaws of the Lion Kilree B 3 and Killamery D 4 are both badly weathered but from the fragmentary remains this scene may be suggested (Fig. 29). In Christian symbolism this scene represents the power of David, the prefigure of Christ, over the lion which represents evil (Réau 1955, 92) and like Daniel in the Lions' Den some of its popularity may stem from its association with the theme of combat between man and beast.

On these two examples two different types are represented. On Kilree B 3 the figure is stretched across the body of a lion-like quadruped (Fig. 29) with a further object above which may be a sheep. This seems to be a version of the iconographic type where David is shown kneeling on the back of the lion. There are several similar versions on other Irish crosses (Roe 1949, 43-5, Fig 2) the closest parallels being on Kells South, where the panel is also set at the end

Fig 29 KILREE AND KILLAMERY
DAVID ICONOGRAPHY



KILREE B 3
DAVID BREAKING THE JAWS
OF THE LION

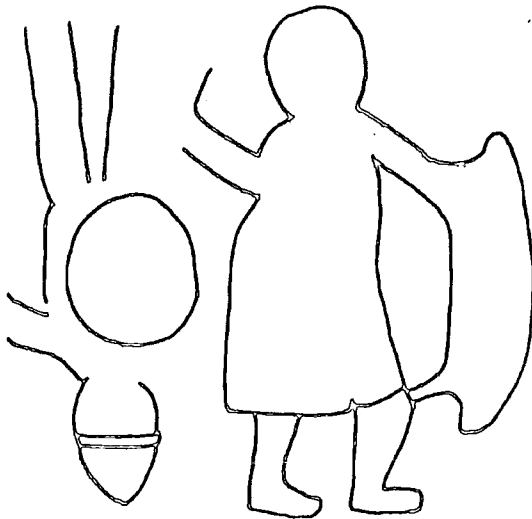

KILLAMERY D 4
DAVID BREAKING THE JAWS
OF THE LION
GOLIATH

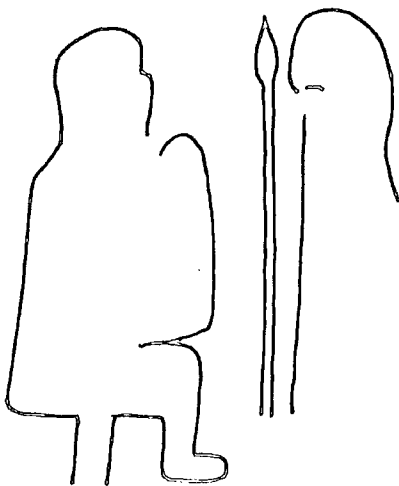

KILLAMERY A 2
DAVID AND GOLIATH FIGHTING (?)

of the horizontal cross arm, and Old Kilcullen where, in addition to David and the lion, the sheep is also depicted, thereby distinguishing this scene from the similar episode involving Samson. There are further, more complex versions on the Market Cross, Kells, Monasterboice West and Durrow I C 4 (see p226). There do not seem to be any other examples of this type represented on insular material so it may have been used specifically in Ireland.

Ultimately, however, the model must have been garnered from elsewhere. Psalter illustrations seem the most likely origin (see p152) but alternatively models could have been drawn from other sources, perhaps metalwork or textiles. For example similar versions are also found on one of the series of early seventh century silver dishes depicting the David cycle from Cyprus (*ibid*; Beckwith 1970, 45, 75) and on a Byzantine textile fragment now in the Victoria and Albert Museum (Dalton 1911, Fig. 371).

Helen Roe (1949, Fig. 2) has suggested that the version on Killamery D 4 (Fig. 29) is of the same type but on close examination a different rendering seems more probable. The figure, David, is standing upright, his right arm raised against a small quadruped which leaps up in front of him. A second figure, placed upside down to the left may represent the fallen Goliath (see Forward), the two episodes thus being merged into a single panel. This type is found elsewhere in Ireland at Donaghmore and possibly on Galloon and Armagh (*op cit*, 45-7, Fig. 3). On Kells South this scene is placed on the opposite horizontal cross arm to the first type and David is shown about to hit the rampant lion with a club (Roe 1966, Pl. VI). David's raised arm on Killamery D 4 may indicate a club which has now been lost due to weathering. A second parallel may be cited with an Irish manuscript, the Southampton Psalter (St John's College, Cambridge C.9 (I.59)) which possibly dates to the early tenth century (Henry 1960, 33ff). Helen Roe (1949, Fig. 2.11) has catalogued the version in this manuscript as Type 1 but as David is not actually kneeling on the lion's back it seems closer to the second type. This model could have entered Ireland via Pictland, where the representations, which are all of this type, seem to stem from that on St Andrews shrine (Allen and Anderson 1903, III, Fig. 365; Henderson 1967, 151-4, Fig. 37). Isobel Henderson (*ibid*) has put forward an interesting hypothesis suggesting that the sculptor of the shrine may have been influenced by

links with Mercia. Another possible parallel is provided by the earliest insular depiction of David and the Lion in the Vespasian Psalter (B.M.Cotton, Vespasian A i) which has strong connections with Canterbury. Here, although the lion is not rampant, David is shown standing erect behind it rather than kneeling on its back (Wright 1967, f53R).

There are two possible ultimate sources for this type. Helen Roe has suggested (1949, 42-3, Fig. 2.16) the classical representation of Hercules wrestling with the Nemean lion while Cecil Curle (Mowbray 1936, 430-1), in pointing out the rarity of this scene elsewhere in Europe, suggests a Byzantine origin which has been influenced by Assyrian or Sassanian prototypes. In addition a man wrestles with a lion in a similar pose on the Gundestrup Cauldron (op cit Pl. II E).

The Fallen Goliath This scene is represented on Killamery D 4 (Fig 29) with the utmost simplicity by placing him upside-down. There are a number of examples of this episode depicted on Irish sculpture (Roe 1949, 47-51) but the only parallel for this type is provided by the Southampton Psalter (op cit, 50; Henry 1960, 33ff, Pl. III). This somewhat crude portrayal with its heavy dependence on abstract design also shows Goliath upside-down, his hand pointing to his eye to demonstrate that he has been struck by the stone. He wears the vestiges of a triangular helmet on his head, a long cloak and has a round shield.

* * * * *

It is possible that the scene on Killamery A 2, which is very weathered, also belongs to this cycle and may show David and Goliath fighting (Fig. 29). There are no other parallels for this in insular representations but it is found elsewhere in Early Christian Art, for example on one of the early seventh century Cypriot silver dishes (Roe 1949, Fig. 5).

The story of David slaying Goliath, as well as being part of the David Cycle, is also included in the Help of God Cycle since it exemplifies God's power to save His servants from great danger (see pl23 and Appendix 4).

* * * * *

As Helen Roe's study (1949) has shown representations from the David Cycle are very common on the Irish sculpture (see pp 182, 194, 222). The precise origins of the scenes on the sculpture are difficult to be sure of but from the few comparisons which have been made with representations in other media one strongly suspects that models were drawn from manuscript sources. In this respect the importance of the Psalter should not be under-estimated. It was an essential aspect of the Irish monastic liturgy (MacNamara 1973; Hughes 1966, 180) and therefore imported psalters are likely to have been in constant demand for copying. The only early Psalter in Ireland is the Cathach of St Columba (Dublin R.I.A.) without figural illustration (Nordenfalk 1947, 151 ff) and so the wealth of iconography which may have provided models for the sculpture has been lost except for later examples, which may, however, provide a clue to the types available (Henry 1960). However, from studies made of early psalters in Anglo-Saxon England it has been possible to gain some idea of the models which may have been available in English Scriptoria and it is possible that a similar variety of foreign manuscripts may also have been present in Ireland. David Wright (1967, 78-9) has suggested that the Vespasian Psalter, which may date to the first half of the eighth century, perhaps the 720's, has links with the Khludov Psalter, a mid ninth century Greek manuscript, and he has gone on to put forward the idea that both may have a common source in some Italian adaptation of a Greek manuscript which may have been illuminated in the period of Justinian. Richard Bailey (1978b, 17, 20) has suggested that the obvious classical elements in the Durham Cassiodorus (Durham Cath. Lib. MS B.II.30), which the majority of scholars date 750-775, draw upon models present in Italy during the seventh or eighth centuries.

b) Religious Processions and Hunting Scenes

The procession on Killamery A 5 and the hunting scenes on Kilree C 3 and 4 and Killamery A 4, although now badly weathered, are clearly of the same genre as scenes on the Ossory crosses (see pp118, 123). However, unlike the Ossory crosses, where they are placed on the bases, here they are more conspicuously placed on the horizontal cross arms of the broad faces which may perhaps underline the possible religious symbolism implied. To place scenes of this type in this position is unusual, the only parallel being the crosshead fragment

from Dromiskin (Henry 1965, Pl. 82; Roe 1954, 113).

The procession on Killamery A 5 is similar to those on Ahenny I B 9 and D 9 (see p118). A figure carrying an object which is probably a wheel head cross and a second carrying a crozier mark this out as an ecclesiastical procession.

The hunting scenes on Kilree C 3 and C 4 have few surviving details but the same rather haphazard concepts of composition and horror vacui seem to apply here as on Ahenny II B 7 and D 7 (see p123). Killamery A 4, where a horseman is shown pursuing a stag may be compared with the simplified version found in the same position on the crosshead at Dromiskin. (Henry 1965, Pl. 82) and to a lesser extent with Bealin B 3 (see p 84).

4) Fantastic Beasts

On Kilree D 4 is a quadruped with a floriated tail and possibly a human head. Its species is not readily identifiable but it undoubtedly belongs with a large number of fantastic beasts found on the sculpture of both Ireland and Pictland. The origins of such beasts are discussed in detail in connection with Roscrea I and Tybroughney (see p159).

5) The Killamery Inscription

The inscription on Killamery A 13 is placed on the butt which is the customary position on the 'Scripture' crosses. Like the inscription on Bealin A 4 the letters are carved in relief; inscriptions on the 'Scripture' crosses, for example Clonmacnoise V A 16 and C 16 (see p246), are incised. It is now completely illegible. Macalister (1949, II, No. 579) recorded it as reading:-

'OR DO MAELSECHNAILL'.

However this is very much open to doubt considering even he admits 'the first four letters are clear, but the remainder is very obscure and densely covered in lichen' (ibid, 25). Even if this reading is reliable it is now impossible to prove. The name 'Maelsechnaill' is of little help as it is extremely common and therefore it is impossible to link it with any particular individual.

6) The Dating of the Monuments

Since nothing can be gleaned from the inscription on Killamery A 13, one is again forced to rely entirely on art historical criteria in an attempt to date them.

Firstly, several comparisons have been made between motives on Kilree and Killamery and Pictish sculpture. The most useful of these are the fret patterns, which, although they have a fairly small repertoire in Ireland, are used extensively on Kilree and Killamery. As has already been suggested (see p 14) it seems likely that the repertoire of fret ornament was developed in Pictland and that certain influences then passed to Ireland. As has already been noted, the large rectangular panels of fret ornament on the shafts of Kilree and Killamery have particular affinities with some of the developed Class II and III slabs, for example, Nigg, Aberlemno III and Rosemarkie II (Allen and Anderson 1903, III, Figs. 72, 228A, 83).

Secondly, the zoomorphic ornament on Killamery C 1 may be closely compared with a group of Vernacular Style metalwork with high plastic relief frequently employing bosses, serpents, dragonsque motives and displayed beasts (see Appendix 2). Metalwork of this kind cannot be dated closely but it would seem to represent the metallic equivalent of sculptural 'Boss Style'.

Otherwise parallels for Kilree and Killamery must be sought in Irish sculpture. Firstly, as might be expected from their geographical proximity, they have some aspects in common with the crosses at Ahenny: the importance of the cross form with regard to the layout of the ornament (see p 96), their careful planning with the recurrent use of 2.5 and 5 cm unit measures (see pp100,106), the types of figural representation and certain kinds of abstract ornament. However, there are reasons for thinking that Kilree and Killamery may be the receivers rather than the initiators. Firstly, apart from the zoomorphic ornament, Kilree and Killamery do not seem to be directly influenced by metalwork techniques although some vestiges of such influence are retained. For example, on Faces B and D of Ahenny I, the shaft is divided vertically into three panels, which is a metalwork convention (see p 97). This division also takes place on Killamery and Kilree but here the panels are not decorated with ornament which is clearly derived from metallic prototypes. Secondly, the pattern of circles delineated by slash marks on Kilree A 7 may have been

influenced by spiral patterns on the type found on the Ahenny crosses which have similar patterns of slash marks. However, although the influence of chip-carving on the Ahenny spiral patterns is very apparent with the ornament on Kilree any metalwork influences are almost completely lost. Thirdly, the perimeter mouldings on Killamery and the corresponding recession of the panels may undoubtedly be compared with the Ahenny crosses but again much of the metallic quality has been lost. Finally, with regard to the iconography, the ecclesiastical processions of Ahenny I B 9 and D 9 may be paralleled with Killamery A 5. However, their positioning is different. On Ahenny I they are situated on the base but on Killamery the scene has been squashed onto the horizontal cross arm on a very small scale and thereby the form of the scene has been almost completely lost.

Secondly, Kilree and Killamery also have many features in common with the Clonmacnoise monuments. The similarities between Killamery and Clonmacnoise IV are particularly noticeable. Structurally they have the same form of crosshead, capstone, perimeter mouldings and the shaft of Face A on both monuments is divided into panels using incised lines. Regarding the abstract ornament, both crosses employ spiral patterns where the spirals are bossed and incised fret patterns. Concerning the figural iconography, the Crucifixion type and its position is similar on both crosses. Parallels for the identifiable Scriptural iconography are also found on the South and Market crosses, Kells. The iconographic and other parallels between Kells South and Clonmacnoise IV have already been noted (see p 86). In addition the large roundel in the centre of the crosshead of Kilree may be compared with Bealin.

Therefore the comparisons which have been made between Kilree and Killamery and the developed Class II and Class III Pictish monuments, the possibility that they derive certain influences from Ahenny I and II and the similarities they share with the Clonmacnoise Group would seem to suggest that they may date to the end of the eighth century or the first half of the ninth. These two monuments are very alike. They have a similar form and an almost identical repertoire of ornament and figural iconography. However, it is impossible to ascribe them to the same sculptor as much of the detail has been lost due to weathering. It is also extremely difficult to describe their relationship to each other except to hint that Kilree may be the older of the two as it

has certain features in common with Bealin while Killamery, a very accomplished piece of sculpture, has more with Clonmacnoise IV (see p134).

Chapter VII THE TYBROUGHNEY & ROSCREA SHAFTS

The similarities between these two small pieces of sculpture were first commented on in detail by Helen Roe (1967, 131). Before this they had been linked with other groups of sculpture primarily because of their geographical proximity, Tybroughney with the Ossory group (Henry 1940, 103, 105; 1965, 139; Roe 1962, 31-3) while Roscrea was associated with the Clonmacnoise monuments (Henry 1965, 143). Although each shaft bears some comparison with sculpture from neighbouring monasteries, the most characteristic ornament on both is a fine array of fantastic beasts of a type which are not common elsewhere. For this reason they will here be considered together.

Where Roscrea I originates from is unknown. Helen Roe (1967, 127-9) has discussed this in some detail and from her detective work several possibilities have emerged. Garravaun Church, which was suggested by Killanin and Duignan (1967, 416), seems unlikely since the only association of the monument with this site was after it had been purchased in Rockforest in 1907 (Roe 1967, 127-8). Far more interesting is John Gleeson's assertion that the piece was from Mona Incha which is not far from Rockforest (1915, 343).¹ However Dermot Gleeson (1947, 152) is of the opinion that this attribution (he makes no reference to John Gleeson's account) is 'probably a guess'. Françoise Henry (1965, 143) suggests Roscrea as well as Mona Incha and even Clonmacnoise and Helen Roe (1967, 129) has speculated on the possibility of other early sites: Aghabo, Clonfert Molua, Kinnitty, Drumcullen, Seir Kieran or Lorrha. However, Roscrea or Mona Incha emerge as the most likely sites, not only because of their geographical proximity to where the shaft eventually came to light and John Gleeson's assertion, but also because of the kind of stone from which the shaft has been carved. It has been impossible to have these stones petrologically examined but careful observation of the type, a yellowish grey sandstone with large pebble intrusions, seems to be almost identical with the stone used for

both Roscrea II and Mona Incha II. As stone was nearly always cut in the neighbourhood (Pers. Comm. Dr. John Jackson Aug. 1977), the only known exception being Clonmacnoise (see p 49), it seems most likely that the shaft originates either from Roscrea or Mona Incha, monasteries founded by St. Cronán which are known to have been closely connected since the latter was the dísert of the former (Kenney 1929, 469).

Roscrea and Mona Incha are situated in the north of the Kingdom of Ossory but Tybroughney is much further to the south on the Munster side of the River Suir (Map II). Nothing is known of the site except its attribution to a little known saint, MoDommac, who is celebrated in the Martyrology of Oengus as the man who introduced bees into Ireland (Stokes, W. 1905, 60, 125, 396). The place name, however, originally Tipra Fachtna, may be translated as 'Fachtna's Well'. There are two saints of this name mentioned in the Martyrology of Oengus (op cit, 420).

1) The Form and Layout of the Monuments

In both cases the original forms of the monuments are difficult to recover. Both now have the appearance of small earthfast pillars, a form which is not unique in Irish Early Christian sculpture, being exemplified elsewhere by the small figural pillars at Carndonagh, Co Donegal (Henry 1965, Pl. 59).

Concerning Roscrea I, Dermot Gleeson (1947, 152) reports a letter he received from H.G. Leask recording a visit to the monument made in 1940 by him and Françoise Henry and putting forward the suggestion that the original form of the monument was a stele or pillar.² Furthermore, Helen Roe (1967, 131) was doubtful whether it 'was ever substantially taller or formed part of some larger work'. Since Helen Roe originally measured and described the monument in 1934 (op cit, 129 ff), the piece has become much more difficult to examine closely as it has now been embedded in concrete right up against a wall rendering both the triangular tenon at the bottom and Face C impossible to view. If Helen Roe's reconstruction drawings are correct (Pl. 36.4) (it should be noted that they are based on her 1934 observations but drawn for the 1967 publication (op cit, 132)) the shape of the triangular tenon would seem to indicate that it was intended to hold the shaft in the ground or in a base. This would be

backed up if one could be certain, as Helen Roe has recorded (op cit, 130), that the decoration was confined to the upper two thirds of the stone. However, the condition of the carving is now such that it is very difficult to see whether the shaft is divided into two or three panels. The hollowing out of Face C, possibly to make a trough, since it was at one point reused for feeding pigs (Roe 1967, 127), seems most likely to have been secondary as the dimensions of the hole seem too massive to have acted as the slot for a mortice and tenon joint. However, it is impossible to tell whether this face was ever carved and therefore whether the pillar was intended to be freestanding. The top of the shaft now would also seem to be the original since there is a moulding along the upper edge of all three carved faces. Therefore, apart from Face C, it seems likely that the extant shaft is substantially the same as when it was originally conceived.

As all four sides of the Tybroughmey shaft are decorated it seems that this monument was intended to be freestanding. The fact that the lower part of the shaft is undecorated suggests it was meant to stand in the ground or perhaps in a stone base. The top does not seem to have been broken off but rather carefully cut through leaving the surface of the stone flat and smooth (Crawford, H.S. 1908b, 271-3). That some height has been lost is suggested by the fact that the top slopes down approximately 3 cm towards Face A and the upper part of the spiral pattern on that face is now lost. However, the amount removed is not easy to determine. H.S. Crawford (ibid) thought the original height was probably greater, perhaps even originally conceived as a monumental cross. This seems unlikely as it is still possible to feel the line of the roll moulding along the top of Face C, suggesting that only a very small slice may have been removed. In addition part of the uncarved area at the bottom of Face D is also missing. The surface of the cut is rather rough and indications of tooling are clearly visible, possibly suggesting some secondary working. Thus the original form seems likely to have been a small shaft which has undergone subsequent alterations, the purpose of which is unclear.

2) The Ornament

a) Beasts

Beasts, both naturalistic and fantastic, form a substantial part

of the decoration on both shafts. On Tybroughney they are found on Faces B, C and D, the creatures being placed side by side or one above the next without being separated by mouldings. However, on Roscrea I, where there are beasts on all three decorated faces, they are placed in separate panels. Animals placed in ones or twos or incorporated into hunting scenes are found on many of the Irish monuments but the predominance suggested by the surviving ornament on Tybroughney is uncommon. The only other Irish monuments where animals are used as prolifically are the two crosses from Moone (see p 188). On the main cross they are found on the central part of the shaft on all four faces (Stokes, M.M. 1901, 542 ff) and on the 'Holed' cross they appear on the crosshead and the fragmentary shaft which is now missing (Stokes, M.M. 1899; Fitzgerald 1899. Both naturalistic and unidentifiable fantastic creatures are included in the repertoire.

On both Roscrea I and Tybroughney the animals have been carved in a low, rather flat relief but on the latter the effect is still surprisingly three-dimensional. This is partly achieved by cutting away the background round each beast to a different level with the result that individual creatures stand out to a different extent. For example on Face B the field round the lion has been carved out to a greater depth than round the stag above. The sculptor has also cut a deep groove parallel with the line of the underpart of the body of each animal thereby giving the impression it is rounded. This is particularly apparent on the lion on B 2. The low relief has also been enhanced by the addition of incised line details such as the body spirals on D 2, a technique used on Bealin and also on some of the early Class II Pictish slabs, for example Aberlemno II (Allen and Anderson 1903, III, Fig. 227B).

On these monuments two types of beast are represented. Firstly, there are animals of a recognisable species, the stag on Tybroughney B 1 and lions on Tybroughney B 2 and C 1 and probably Roscrea I D 1. In addition Helen Roe (1962, 33) has suggested the quadruped on Tybroughney D 1 may be a hyena but this seems unverifiable. Of these both the stag and the lion are found on the cross at Moone as well as on the monuments of the Clonmacnoise group (see pp188, 81). The stag may be paralleled with that on Banagher A 2, where it is also shown singly, and elsewhere stags form an essential ingredient of hunting scenes. The lion is characteristic of the Clonmacnoise group. Indeed,

the lion-like creature on Roscrea I D 1 seems to be enmeshed in interlace threads very similar to the lion on Banagher C 2 (see p 81).

The second type consists of purely mythical beasts. Three kinds are represented: a centaur on Tybroughney C 2, a manticora on Tybroughney D 2 and two bird headed monsters on Roscrea I A 1 and B 1. The closest comparisons for these may be found with a class of monsters which characterise a group of Southern Pictish monuments concentrated on the sites of Meigle and St. Vigean. Not only are the same species represented but there are also stylistic affinities. In particular the form of the beasts' feet, for example on Roscrea I B 1, is usually considered a distinctly Pictish feature (Curle 1939-40, 86) although it must be said it is also a feature of some of the beasts on the Clonmacnoise group monuments and Hiberno-Saxon manuscripts, for example the Book of Durrow lion (Nordenfalk 1977, Pl. 7).

The centaur on Tybroughney C 2 is clearly paralleled on the early Class II slab, Glamis II (Allen and Anderson 1903, III, Fig. 234A), where it is placed in the top right hand corner on the front of the slab, being balanced by a lion on the left. The two centaurs are very similar except that the one on Glamis faces in the opposite direction and appears to be beardless. Further comparisons are supplied by centaurs on the developed Class II slab, Aberlemno III and the impressive Class III monument Meigle II (op cit Figs. 228B, 311B). In both cases the creatures are placed on the back of the slabs, and in addition to the axes in either hand, they carry a leafy branch under their arms. In Ireland there seem to be no other examples of centaurs carrying axes but similar creatures with bows and arrows are found on the bases of two of 'Scripture' crosses, the Kells Market cross³ and Monasterboice South (Roe 1966, Pl. XII; Macalister 1946, Pl. III). In Pictland this type is found on the probably late freestanding cross from Camuston (Allen and Anderson 1903, III, Fig. 263A).

The splendid manticora on Tybroughney D 2 has a human head with a beaked nose, a leonine body and a long, curling scorpion's tail. There may possibly be a similar beast on Kilree D 4 (see p 153) but it is certainly paralleled in Pictland on the recumbent grave slab, Meigle XXVI (op cit, Figs. 318D, 320). Here the beast, a far more substantial monster, is depicted pursuing its human prey, but some of the details, especially the prominent beaked nose, are very comparable with Tybroughney D 2. There is another similar monster with a long curling tail on the front of a slab from Rossie Priory (op cit, Fig. 322A).

The bird-headed monsters on Roscrea I A 1 and B 1 are similar to griffins but are much less elegant than those on Bealín C 3 and Clonmacnoise I B 1 (see p 81). Helen Roe (1967, 130) identified the creature on Roscrea I A 1 as the 'medieval concept of an elephant' but this is undoubtedly incorrect. A close examination of the carving reveals a beast with a bird's head and a hooked beak which it uses to gore an object, perhaps a human figure, which it holds between its front left leg and its beak. The parallels for both these monsters are undoubtedly Pictish rather than Irish. B 1 may be closely compared with a beast on Meigle X, now missing (Allen and Anderson 1903, III, Fig. 344). Here a formidable monster with a large, jagged beak gores the head of a struggling man whom it holds down with its feet. Other more griffin-like beasts are shown devouring prey on Meigle IX and Woodrway (op cit, Figs. 343B, 258A) and griffins and bird headed monsters similar to A 1 are found on St Vigean's XIX and XX and Meigle XXVI (op cit, Figs. 290A, 291, 318C).

The possible oriental origins of the lion and griffin and the Christian symbolism of the stag have already been examined (see p125) but they may equally well be derived from illustrated manuscripts depicting beasts, both naturalistic and fabulous. Although Françoise Henry is reported to have had her doubts about the Christian significance of the creatures on Roscrea I (Gleeson, D. 1947, 152) they have generally be regarded as being derived from the Bestiary where the beasts are characterised by attitudes and associations which are given a Christian symbolic meaning (Allen and Anderson 1903, I, XL ff; Roe 1962, 33; 1967, 131). The problem is that this work is a compilation which has its floruit during the twelfth century although it is known to have been circulating earlier (White 1954, 234). It draws on many sources and it is more difficult to surmise precisely what manuscripts the sculptors of Ireland and Pictland may have had at their disposal for use as models.

Animal symbolism was already familiar to the early patristic writers who believed that every element of nature had its spiritual significance (Wallace-Hadrill 1968, 122 ff).⁴ These early writers were also aware of a work called the Physiologus. This was the direct ancestor of the Bestiary and seems a likely source of inspiration for the Hiberno-Saxon fantastic beasts. The book was already in existence by 496 when it was claimed to be heretical at a synod convened by

Pope Gelasius (Allen 1887, 237 Note 3; Allen and Anderson 1903, I, XLI) but it must be considerably older as it is quoted by Justinus the Martyr (ob. 166), Origen (ob. 254/5), Tertullian (ob. 230) and Clement of Alexandria (Carmody 1941, 97). It is made up of descriptions of beasts, both natural and mythical, drawn from both classical and Biblical sources, and to each one is attached attitudes of religious significance. The lion, the griffin, the stag and the manticora are all included although not the centaur.

The Physiologus seems to have been extremely popular (White 1954, 232) and its influence may be detected to some extent in the Anglo-Saxon sources. Three early English poems, all written before 800, the Whale, the Panther and the Partridge (now fragmentary) all seem to be based on some otherwise unknown version of the Physiologus (Gordon 1954, 252-5; Robin 1932, 8). It also seems that Bede knew of a treatise called De Naturis Bestiarum and in the second half of the tenth century a Liber Bestiarum was amongst the books donated to Peterborough by Bishop Aethelwold (Allen and Anderson 1903, I, XLI).

A possible clue to the types of illustrated manuscript which may have been available to Hiberno-Saxon artists is provided by the Physiologus of Bern (Codex 318). This is a ninth century manuscript of the Reims school and extremely important because it is the oldest surviving illustrated text and, moreover, it seems to have drawn upon a very much older model, perhaps an Alexandrian manuscript dating to the fifth or early sixth century (Woodruff 1930, 226-53). In each case the animals are drawn as portraits. For example, the lion is pictured being blessed by Jacob, covering its tracks, sleeping with its eyes open and breathing life into its cubs (op cit, Figs. 24, 2, 16, 29) and in all these it is depicted in profile, the emphasis being on the portrait of the beast. Equally, the beasts carved on the Tybroughmey shaft, which includes a lion, are also portraits.

Another work on which the Bestiary drew and which could have provided suitable models is the Etymologiae by Isidore of Seville. This compilation, which is concerned with a gathering together of secular knowledge (Bréhaut 1964, 30 ff), includes a section on beasts both natural and mythical. However, unlike the Physiologus, Isidore does not seek to draw moral or spiritual lessons from them (op cit, 222-3) and therefore perhaps it is less likely that models from this work should be translated onto stone where they seem to have a Christian

significance. Despite this it seems perfectly possible that an illustrated version may have exerted some influence since it is known that Isidore's works enjoyed great popularity at an early date in Irish monastic circles, perhaps reaching Ireland via Britonia, a Celtic see in Galicia (Hughes 1961, 65-6; Hillgarth 1961-2, 185-9). For example Isidore's De Ortu was being quoted by Irish authors by 661.

In addition Isobel Henderson (1967, 138) has suggested that a work called the Marvels of the East could have acted as a sampler for the Pictish sculptors. There is an Anglo-Saxon version of this manuscript dated c. 1000, Cotton Vitelluis A XV, and Montague Jones (1929, Intro.) has also suggested that a version of this may have been part of the Cosmographia which Abbot Ceolfrith gave to King Aldfrith. However, judging by the descriptions and illustrations given in the Cotton Vitelluis A XV, the Marvels of the East seems to have been preoccupied with fantastic men rather than beasts. For example paragraph 22 describes men fifteen feet high and ten feet broad, who have ears like winnowing fans (op cit, 57). It thus seems very unlikely to have provided models for the Irish animals although it could perhaps account for some of the more extraordinary conglomerates on the Southern Pictish stones.

The centaur is not included in Medieval Bestiaries or in the Marvels of the East. It does however have a Christian symbolic meaning being associated with incarnations of demons (Réau 1955, 119). The origins of this fantastic beast are undoubtedly classical but it continues to appear sporadically during the early medieval period. For example, apart from the Irish and Pictish monuments, a female centaur is one of the designs found on Anglo-Saxon sceattas (Curle 1939-40, 89; Brown, G.B. 1915, 86-8, Pl. VI nos 8 and 11), and there is also an example of one of the sculptural friezes from Breedon (Cramp 1977, 195).

Finally, mythical and fantastic beasts are also found on the Carolingian Continent and thus models could also have been drawn from this source. A particularly fine example is provided by an ivory from the Louvre dated c. 850 showing Adam and Eve in Paradise accompanied by fantastic beasts including centaurs (Lasko 1972, 47-8, Pl. 43) (see p239). There is also another ninth or tenth century ivory in the Museum de Cluny, Paris, which depicts men and fantastic animals, centaurs and horned beasts, entwined in acanthus scrolls (Goldschmidt

1918. I, Nos. 156-8).

Therefore the natural and exotic beasts found on Roscrea I and Tybroughney may be derived from a number of sources. The sculptors may have been drawing on oriental influences similar to those already discussed in connection with the Clonmacnoise monuments (see p 83). Equally, books such as the Physiologus may also have been at hand to provide models.

b) Spirals

Both shafts make use of spiral ornament in the form of roundels. These are found on Tybroughney face A and Roscrea I A 1 and B 2. There are also traces of a large spiral with a bird's head terminal on Roscrea I D 2.

In contrast to the elegant low relief of the beasts on the Tybroughney shaft the spiral roundel on face A is remarkably bold. The field is deeply cut, the spiral bands highly modelled and the hollowed spirals add to the three dimensional-effect. However, the whole gives the impression of being rather roughly finished. In addition the roundel has been placed on an area of the shaft which seems to have been originally delineated as a square panel. The lines indicating this may still be seen quite clearly at the bottom of the roundel. The roundel also seems slightly too large for the space available. Thus the roundel moulding merges with the perimeter moulding on either side. This all suggests inferior craftsmanship compared with the beasts and there seems a distinct possibility that the sculptor who carved the spirals was not the man who carved the beasts.

Stylistically, details of the roundel may be compared with ornament on Ahenny I and II situated only a few miles to the north. On these two crosses there are a number of spirals with bird's head terminals, Ahenny I A 1 and C 2 and Ahenny II C 2, while the only other examples of hollowed spirals are found on Ahenny II A 7 and A 8 (see p102). The practice of tucking a small spiral between two larger spirals to act as an expansion is also found on Ahenny II A 7 and Clonmacnoise IV C 2. In metalwork a spiral roundel from Kommes in Norway (Peterson 1940, 22-3, Fig. 12) has studs tucked between the spirals in a similar manner. However, unlike the Ahenny spirals, there is no direct metallic influence on the carving technique of the Tybroughney roundel.

Roscrea I A 2 has no distinctive features but the roundel on B 2 is composed of small bosses which may once have been joined by spiral ornament. There is an almost identical roundel on the upper crossarm of the West face of Kells South (Roe 1966, Pl. IV) and there are similar roundels on Tihilly C 1 and Kinnitty I C 1 and further comparisons may also be made with 'Boss Style' monuments in Southern Pictland (see p177).

The details of the spiral on Roscrea I D 2 are impossible to recover. In 1934 Helen Roe (1967, 130) described it as 'a large circular composition of boldly interlaced serpentine creatures with bird-like heads and fishy tails'. Any serpents there may have been are now lost. The original motif seems more likely to have been similar to either Clonmacnoise I D 2 or Kilree A 1.

3) The Dating of the Monuments

Françoise Henry (1940, 103) dated the Tybroughney shaft with the Slievnamon monuments to the first half of the eighth century. Helen Roe (1967, 130, 132), however, suggested a date during the late eighth century for Roscrea I which she placed within the general orbit of the Ossory and Clonmacnoise groups.

Although some parallels have been suggested with these for both shafts, much closer comparisons have been made with monuments in Southern Pictland, especially those centering on the two sites of Meigle and St Vigean. The Roscrea and Tybroughney shafts share with these monuments a predilection for the depiction of monsters. From whatever models such creatures were derived, it seems possible that they reflect the undoubted popularity of exotic beasts in the last quarter of the eighth and first quarter of the ninth centuries in Anglo-Saxon England (see p 83) (Cramp 1978, 8; Henderson 1978, 55). Isobel Henderson (Pers. Comm April 1977) classifies the Meigle school of sculpture with the mature Pictish 'Boss Style' monuments exemplified by the St Andrew's sarcophagus and the slabs of Easter Ross with perhaps a second wave of fantastic animal models appearing in the ninth century which may be exemplified by the Drosten stone (Henderson 1978, 55; Allen and Anderson 1903, III, Fig. 250). Robert Stevenson (1955, 121-3) would prefer to see the majority of Meigle monuments as somewhat later and after the first flush of 'Boss Style'

with Meigle II perhaps as late as c 850 because of the absence of Pictish symbols. The monsters are exhibited on a wide range of monument types, many of which do not have symbols or are otherwise insignificantly placed and 'declined' (op cit, 101-6). This, together with the use of small bosses, a feature of the undoubtedly ninth century monuments centring on Kells, argues for their placement fairly late in the Pictish series.

A similar date during the first half of the ninth century would therefore seem acceptable for the Roscrea and Tybroughney shafts. If their present forms may be seen as substantially the same as their original, they may provide two examples of less ambitious sculptural projects which were being carved at the same time as the more monumental high crosses.

Chapter VII FOOTNOTES

1. Speaking of the shaft, which he describes as a font, John Gleeson says:

'In the Protestant history of Killaloe diocese, written by Canon O'Dwyer, it is stated that there was no water font in the monastery of Mona Incha. If the Canon was living he could be shown the beautifully carved piscina and font, which belonged to this monastery and also a very ancient holy waterfont in grit stone of the eighth or ninth century, which must have been dug out of a wall judging by its shape.' (Gleeson, J. 1915, 343)

2. Letter from H.G. Leask to Dermot Gleeson, dated November 1940:-

'It is not a cross shaft. I have yet to meet a carved cross with a shaft almost square in plan. Some of the carvings are plain enough, two almost horse like, or perhaps deer-like animals, which do not belong to cross iconography. The other patterns are greatly detailed but one is certainly a group spirally connected, I think, while there are circular designs which seem to have had interlace of perhaps zoomorphic character. Melle. Henry and I think the stone is a stele, a carved pillar of the same family as the Tybroughney stone and earlier than the crosses.' (Gleeson, D. 1947, 152).

3. Helen Roe (1966, Pl. III) has recorded another centaur on Kells South but her identification seems rather suspect as the beast does not appear to have a horse-like body.
4. This concept is well illustrated by the writings of Origen.

He writes:-

'Ita igitur cuncta secundum ea quae praefati sumus, ex visibilibus referri possunt ad invisibilia, et a corporalibus ad incorporea, et a manifestis ad occulta, ut ipsa creatura mundi tali quadem dispensatione condita intelligatur per divinam sapientiam, quae rebus ipsis et exemplis invisibilia nos ad visibilibus doceat, et a terrenis nos transferat ad coelestia.'

Homiliae in Canticum Cantiorum III, v 9.
(Migne 1857-1912, XIII, Col. 175).

'All the things in the visible category can be related to the invisible, the corporal to the incorporeal, the manifest to those that are hidden, so that the creation of the world itself, fashioned in this wise as it is, can be understood through the divine wisdom, which from actual things and copies teaches us things unseen by means of those that are seen, and carries us over from earthly things to heavenly.'

5. Ansell Robin (1932, 14) has neatly summarized the various sources which make up the Physiologus, and which were later incorporated into the Bestiary.

Chapter VIII KINNITTY, TIHILLY AND DRUMCULLIN

Kinnitty is situated on the North Western edge of the Slieve Bloom mountains, that is to the north east of the ancient Kingdom of Ossory and in the territory of the Laigin (Mac Niocaill 1972, 35-6) (Map III). The monastery is associated with St. Finan, a Kerry saint and follower of St. Brendan (Kenney 1929, 421) but very little is known about the foundation since there is no record of it in the annals.¹

The original location of the cross at Kinnitty is unknown although Olive Purser (1918, 74) records that it was found nearby. Following George Cunningham (1976, 56), there seems no reason to doubt that it comes from the immediate vicinity. However, in the gazeteer the crosshead and shaft have been separated from the base, and are termed Kinnitty I and II respectively. There are a number of reasons for this. Firstly, and most important, Kinnitty I is sandstone while Kinnitty II is limestone. Admittedly Kinnitty lies just on the junction between the old red sandstone of the Slieve Bloom and the limestone of the west (O.S. geology map, sheet 117), but it would seem extremely unusual to combine two completely different stones in one monument. Secondly, it is unknown whether the shaft and crosshead fragments were originally found in association with the base. Furthermore, it is now impossible to reconstruct the dimensions of the socket of Kinnitty II so it is uncertain whether the shaft of Kinnitty I would originally have slotted into it; this has now been achieved with the aid of concrete. Lastly, there are no identifiable links between the bands of interlace ornament on Kinnitty II and the general pattern of decoration on Kinnitty I.

Drumcullin is situated about a mile to the North West of Kinnitty on the Camcar River (Map III). Again, little is known of the history of the monastery except for its association with St. Barrind, another follower of St. Brendan (Lanigan 1822, II, 219).

Approximately sixteen miles to the North East on the Silver River lies the site of Tihilly, not far from the great Columban monastery of

Durrow. Tihilly, however, seems to have associations with a number of other saints, St. Fintan (Reeves 1857, 21), the woman Cera, a follower of St. Fintan (Lanigan 1822, III, 129) and St. Telli. Otherwise little is known apart from occasional references in the annals (Williams 1897, 133-4).

The obscurity of these three sites perhaps accounts in part for the fact that their monuments have seldom been commented upon. Françoise Henry (1933, 137) was not prepared to assign either Kinnitty or Tihilly to any particular group while Drumcullin has merely been classified as one of a number of smaller monumental crosses (Henry 1967, 137). Here the three are treated together, Tihilly and Kinnitty I being closely linked, while the surviving ornament on Drumcullin I has its closest affinities with these two monuments.

1) The Form and Layout of the Monuments

The form and layout of Tihilly and Kinnitty I may be closely compared although Tihilly is on a smaller scale.

A tentative reconstruction of the crosshead of Tihilly may be suggested as Type 3a (Fig. 30) and from what survives of Kinnitty I and Drumcullin I these seem likely to be similar. The position of the wheel arcs on Tihilly corresponds with the Type 3 crossheads found amongst the Northern 'Scripture' crosses (Fig. 39), the difference being that with Tihilly the horizontal cross arms barely project beyond the wheel. One would expect the upper cross arm to have been elongated, almost de rigueur amongst the Irish monuments, perhaps with the addition of a house shaped shrine as there once was on Kinnitty I (Henry 1933, Pl. 92) (Pl. 28.21).

The shape of the shaft of Kinnitty I is most unusual since it tapers from top to bottom on the narrow faces, the opposite way from usual. This would seem to be dictated by the original shape of the stone block from which the monument has been carved. This curious shape also accounts for much of the difficulty which has been encountered in carrying out the decoration on these two faces.

The shaft panels have been set out in a similar fashion on both Tihilly and Kinnitty I. Both the broad and narrow faces are divided into three panels, usually with the addition of a further half size panel at the bottom. An undecorated area is left at the bottom of

Fig 30

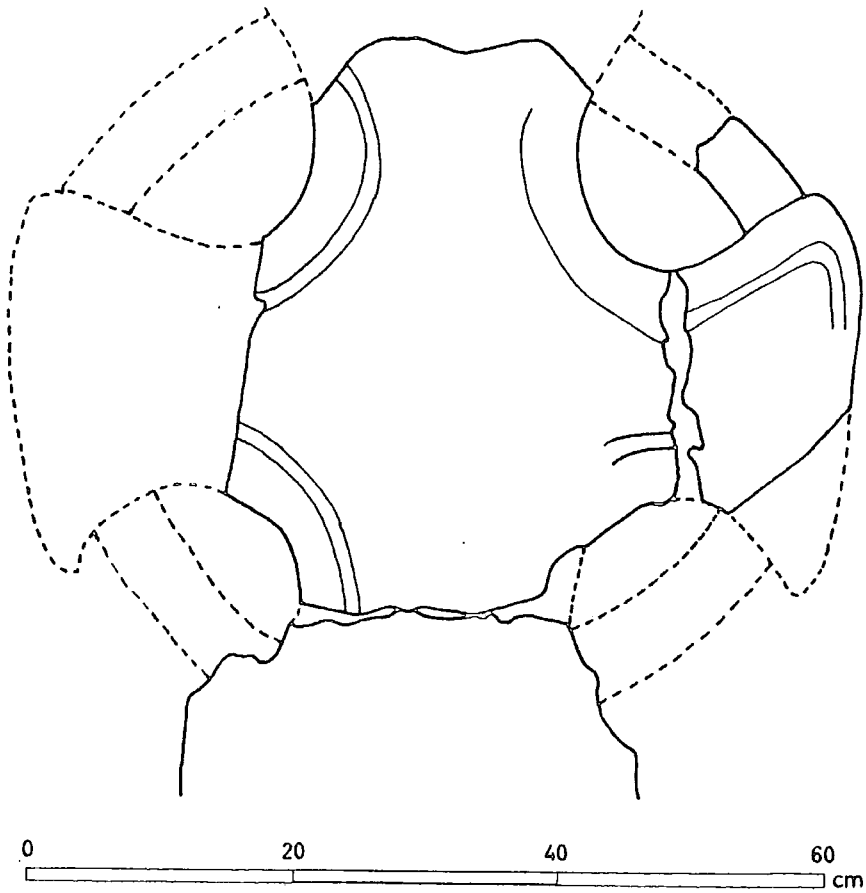

TIHILLY, RECONSTRUCTION OF
CROSSHEAD

the shaft but they do not have a butt. The division of the face of the shaft into three or four panels is a feature of many² of the Northern 'Scripture' crosses, for example the Market Cross, Kells and Monasterboice South (Roe 1966, Pls. VII-XI; Macalister 1946, Pls. I and II). This is also found on Durrow I and Clonmacnoise V (see p203). The horizontal bands on the perimeter mouldings and the vertical breaks in the picture frame mouldings found on Tihilly and Kinnitty I are also a feature of these two crosses as well as some of the Northern 'Scripture' crosses, the former, for example, on Monasterboice South and the latter on Monasterboice West (op cit, Pls. XII, XIII). The horizontal bands on what are otherwise plain roll mouldings may perhaps retain some influence from metalwork bindings (see p 97).

In contrast with the monuments discussed in the foregoing chapters, the bases of Tihilly and Kinnitty II are smaller and they are not a major vehicle for either ornamental or iconographical display. Drumcullin II is simply a crude cylindrical block of stone with a socket in it. The most usual shape for the base of an Irish cross is a truncated pyramid. However, the base of Tihilly is round and its only ornament is three undecorated raised bands. The best parallel for this is Kells North (Roe 1966, Pl. XX). This isolated cross base, no other part of the monument is extant, is round and is decorated with a horizontal band of plaitwork ornament. Some of the Barrow Valley crosses, particularly Graiguenamanagh I (see p188) and St. Mullins also have slightly rounded bases but this may be purely fortuitous, the shape being dictated by the hardness of the granite from which they are carved. Kinnitty II is a more usual shape but again the ornament is confined to horizontal bands decorated with interlace. Cross bases with little or no ornament are also a feature of some of the 'Scripture' crosses, for example Durrow I (see p204) and Monasterboice West (Henry 1964, Pl. 68).

2. The Ornament

At first glance the figural panels would seem to dominate the ornament of both Tihilly and Kinnitty I. However, this impression is misleading. It is true that the figural panels are situated in the more prominent positions, the Crucifixion on the crosshead of Face A, and others on the broad faces of the shaft (Tihilly A 3, Kinnitty I A 3,

C 6) but it is the abstract ornament which is used more extensively. As Drumcullin I is fragmentary the original amount of figural and abstract ornament is unknown.

a) Interlace

Interlace is used fairly extensively amongst this group. On the shafts it is found both on some of the prominent panels of the broad faces (Tihilly A 2, A 4, C 8; Kinnitty I A 2, A 4, C 9) and on some of the long thin rectangular panels of the narrow faces (Tihilly B 2, B 5, D 1, D 4; Kinnitty I B 4, D 1, D 3; Drumcullin I B 1). It is also employed on the irregularly shaped panels on the cross arms (Tihilly C 2, 3, 4, 5; Kinnitty I C 2, 3, 4; Drumcullin I C 2, 3, 4) and there are horizontal bands of interlace ornament on Kinnitty II.

The interlace patterns on Tihilly and Kinnitty I are constructed on a square grid indicating the crossing points of pairs of strands. They both use a 2 cm unit measure extensively. The strand width on Kinnitty I is usually 1.5 cm, that on Tihilly showing more variation, $1 < 1.5$ cm. The use of a 2 cm unit measure and 1.5 cm strand width is important since these are also used for the construction of interlace ornament on Durrow I (see p242).

The interlace on Kinnitty II seems to be constructed in a similar way but using a larger unit measure, 3 cm, and a broader strand width, 2 cm.

Kinnitty I A 4 may show the only demonstrable example of the use of some kind of template for the construction of an interlace pattern (see p 19). It will be seen immediately that the lower units of this Basic A pattern have a lopsided appearance. This is due to the fact that they are wrongly aligned in relationship to the units above. If the two lower units are moved exactly 2cm (the unit measure) to the left they will then be correctly aligned. This wrong alignment is also indicated by the peculiar freehand appearance of the strand in the bottom right hand corner of the panel. This seems to argue for a template which forms a single unit of the interlace pattern. The template could be placed on the grid and drawn round; the loose strands could then be joined up as necessary. Here the template seems to have been placed incorrectly.

The repertoire of interlace ornament on Tihilly and Kinnitty I is closely comparable and a similar variety of strand types is used.

The interlace types used are summarized in Fig. 30.

	Kinnitty I	Tihilly	
A	Basic A	✓	Fig. 31.
	Basic A turned	✓	
	Basic A double stranded	✓	
B	Half B	✓	
	Half B double stranded	✓	
	Simple B	✓	
	Simple B with outside strands	✓	
C	Turned C	✓	
	Encircled C	✓	
	Encircled & Turned D	✓	
	Turned E	✓	
	Plaitwork Mesh	✓	

On the whole fairly simple patterns are favoured with one or two more complex encircled patterns on the broad faces. Some of the patterns are made more interesting by the adoption of a double strand. The panels on the narrow faces of the shafts are, for the most part, simple six strand patterns, the exception being Tihilly D 1, where an eight strand pattern, Turned E, is used, the lack of space giving it a somewhat squashed appearance. It is also interesting to note that some of the patterns on Tihilly seem originally to have been designed for panels shorter than those on this monument. On some of the interlace patterns it has become necessary to introduce a simple two strand twist or a half element at the bottom in order to fill the vacant space, for example Tihilly A 2, B 2, D 1.

There are undoubtedly close links between the interlace patterns on Tihilly and Kinnitty I and those on Durrow I regarding both the ornamental repertoire and the constructional detail (see p242). On a broader front the ornament may be compared with the Clonmacnoise group where a similar variety of patterns (Fig. 8) and strand types are also found. Clonmacnoise IV shows particular parallels. For example, Tihilly B 2, Simple B with outside strands, may be compared with Clonmacnoise IV D 5 and Kinnitty I D 3, Simple B, with Clonmacnoise IV B 6. Other patterns are used more widely amongst the Clonmacnoise monuments, for example Kinnitty I D 1, Basic C Turned, may be compared with Clonmacnoise II B 1, III B 1 and IV B 7. Encircled interlace patterns are found amongst the Clonmacnoise monuments too but are also used elsewhere, for example Kells South and Monasterboice South (Roe 1966,

Pl. II; Macalister 1946, Fig. 9).

The layout and ornament on face C of Drumcullin is very similar to that of Tihilly and Kinnitty I and therefore demonstrates a link between these three monuments. In each case the centre of the cross-head is decorated with a spiral roundel, the cross arms with a somewhat disorganized mesh of interlace strands. Françoise Henry (1970, Fig. 34b) interpreted the strands on Drumcullin as snakes but after close examination a somewhat clumsy interlace pattern seems far more likely. However, on Kinnitty I C 3 the strands do have a somewhat serpentine appearance. The use of an interlace mesh on the cross arms with a central spiral medallion is paralleled on the fragmentary cross-head from Monasterboice (Roe 1954, Pl. X).

b) Zoomorphic Ornament

A similar repertoire of zoomorphic motives is found on both Tihilly and Kinnitty I but ornament of this kind is less frequently used than interlace. It is found on both the broad and narrow faces of the shafts. There is no surviving zoomorphic ornament on Drumcullin I.

Processions of Quadrupeds with Spiralled Bodies Tihilly D 2 (Fig. 16) shows a procession of dog-like quadrupeds with spiralled bodies. The pattern is two and a half registers long, the half register being rather clumsy and squashed. As with the interlace ornament this may suggest that the pattern was originally designed for a panel of a different length and the sculptor was somewhat uncertain how to counteract the problem.

This procession may be compared with those already discussed in connection with the Clonmacnoise monuments (see p 65). However, in this instance, although the quadruped's body stretches over two registers, as with the Torshov Mount (Fig. 15), the shape formed is different, since the diagonal made by the neck and front paw goes in the opposite direction. The effect is similar to Clonmacnoise IV D 8 (Fig. 16) although on Tihilly the line of the quadruped's body has been retained without a break. The closest parallel for this is provided by the procession of quadrupeds on the lower right hand wheel arc on the west face of Monasterboice South (Macalister 1946, Pl. IX). The stylistic detail of the enlarged paws of the quadrupeds

may be derived from manuscript illumination (see p 81). The lion in the Book of Armagh has accentuated paws (Henry 1974, Fig. 51) and this detail continues right through to the early twelfth century, for example in B.M. Harley MS 1023 (Henry 1970, 53, Pl. 7).

Related to this motif is the panel of interlaced quadrupeds on Kinnitty I C 7 but here the back leg and tail of each creature have become extended to form the interlace pattern. The panel is not altogether competently carried out since the creature's head in the bottom right hand corner is greatly enlarged and the form of the creature in the bottom left hand corner has been almost completely lost in the attempt to fit it into the available space. This pattern however is unusual since it seeks to combine a complete interlace pattern with a zoomorphic element which is not merely a terminal but part of the actual interlace pattern itself. There seem to be no direct parallels for this combination.

Confronted Quadrupeds This motif is found on Tihilly B 4. It is $1\frac{1}{2}$ registers high, again suggesting it was originally intended for a panel of a different size. It is related to the motif showing a pair of confronted beasts with spiralled bodies on Clonmacnoise I B 3 (see p 66) but on Tihilly the heads of the quadrupeds, although the carving is much less accomplished, also share features with the quadrupeds on the narrow faces of Duleek North (Crawford, H.S. 1926b, Fig. 1).

Confronted Birds with Interlaced Necks Dissimilar versions of this motif are to be found on Kinnitty I C 5 and Tihilly C 9. The former, a panel well designed to fit into the awkward shape of the lower cross arm, shows birds with crests, spiralled wings and long tail feathers. These features suggest the birds are peacocks, symbols of the Resurrection (Cadbrol and Leclercq, 1907-52, XIII, 1075 ff; Lothar 1929, 25), which are frequently encountered in Early Christian art. If so this panel is well placed as a counter to the Crucifixion on the opposite side of the cross in the same way as the Crucifixion is countered by the Last Judgement on so many of the 'Scripture' crosses (see p218). Peacocks are not found elsewhere on the Irish sculpture but they are found in the Book of Kells (e.g. f32V, 4202R) and the birds on Kinnitty I may be compared with these and with other interlaced bird motives to be seen throughout the manuscript (e.g. f124R). Indeed, interlaced birds are very common Hiberno-Saxon manuscript motif especially in the Lindisfarne

Gospels and the Lichfield Gospels (e.g. Nordenfalk 1977, Pls. 19, 26).

The species of birds on Tihilly C 9 is not possible to determine, although Helen Roe (1965, 115) has suggested that birds such as these may be reminiscent of the doves which probably represent the souls of the faithful found on some monuments, for example the Fahan Mura slab (Henry 1965, Pl. 52). The reason for the addition of the human face-mask is obscure but there are other instances of human face-masks being incorporated into the ornament and their possible significance is discussed in more detail in connection with Clonmacnoise V B 9 and D 9 and Durrow I B 6 and D 6 (see p 244). The birds on Tihilly C 9 are probably also derived from manuscript motives or perhaps birds such as those found on the Sondre bucket (Henry 1965, Fig. 25c). However they may also be compared with a pair of birds placed above the Crucifixion on Monasterboice South (Macalister 1946, Pl. II) and with the ornament of the openwork crest on the Kells crozier. Maire MacDermott dates the latter to the eleventh century but believes it to be 'a conscious imitation of an early motif' (1955, 101, Fig. 4, Pl. XXVII).

Serpentine Beasts with Interlaced Bodies There is one example of a beast with a serpentine body forming an interlaced pattern on Kinnitty I B 2. The creature appears to grasp one of the loose interlace strands in its mouth but at the bottom, although one strand terminates in a fishtail, the other hangs loose. Its head is rather unsnake-like, since it has an ear, but otherwise this motif may be seen as another version of those found on the Clonmacnoise monuments, Bealin D 5 and Banagher B 1 (see p 64).

Anthropomorphic Motives Anthropomorphic motives are difficult to identify on these two monuments but there are two possible examples. The first, Kinnitty B 1, seems to show two half figures emerging from a central spiral. They have raised arms which would appear to be in the orans position, although it is not clear whether this is intentional. The fact that their heads are face on is unusual but it could be a crude version of the type of anthropomorphic pattern which appears in the Canon Tables of the Book of Kells (e.g. f1V) or the Book of Mac Regol (Fig 17, see p 69) and also on the North face of the Market Cross, Kells (Roe 1966, 42).

The second panel, Tihilly C 7, is badly weathered and the actual form of the ornament is not now decipherable. However, from the

fragments which survive, especially the interlace loops on the left hand side of the panel, it may be possible to suggest that this is an anthropomorphic interlace design similar to those on the west face of Kells South, the South face of Monasterboice South and Clonmacnoise V B 12 (op cit, Pl. IV; Macalister 1946, Pl. VI. 27) (see p244).

c) Spirals

Such ornament is used fairly extensively on these monuments. There are spiral roundels on the crossheads of all three crosses (Tihilly C 1, Kinnitty I C 1, Drumcullin I C 1). Otherwise there is one spiral panel placed on the broad faces of the shaft, Kinnitty I C 8; the rest are on the narrow faces (Tihilly B 3, D 3; Kinnitty I B 3, D 2).

The spiral roundel placed at the centre of the crosshead is one of the characteristics of this group and is also one of the more diagnostic features for the purposes of comparison. On these crosses the Crucifixion is placed on one side of the crosshead, a spiral roundel on the other rather than a second iconographical panel, most usually the Last Judgement, which is found in this position on the majority of the 'Scripture' crosses (see p218). The combination of spiral roundel and Crucifixion placed on either side of the crosshead is paralleled on Duleek North and possibly on the fragmentary cross-head from Monasterboice now in the National Museum (Crawford, H.S. 1926b, Pl. IV; Roe 1954, Pl. X). On Kells South there is a spiral roundel on the East face of the crosshead, Christ in Majesty being placed on the West with the Crucifixion underneath at the top of the shaft (Roe 1966, Pls. II, IV). The spiral roundels on Kells South and Kinnitty I are closely comparable since both are contained within a square panel ornamented with interlace. The spirals on Kinnitty I, Kells South, Duleek North and also the roundels on the crosshead of the east and west faces of the monument at Tynan (Roe 1955, Pls. VII-VIII) are all raised into low bosses. In Southern Pictland small bosses, sometimes grouped into roundels, are a feature of some of the Class III monuments which Robert Stevenson (1955, 121-3) has termed 'late Boss Style'. These have spiral roundels raised into small bosses situated at the centre of the crosshead. Good examples are to be found on Meigle II, Fowlis Wester and the freestanding cross fragment

from Edzell³ (Allen and Anderson 1903, III, Figs. 311A, 306A; Stevenson 1958-9, 42, Pl. VI). A spiral roundel placed in the same position but without the raised bosses is found on the early Class II slab Aberlemno II (Allen and Anderson 1903, III, Fig. 227A) and therefore could provide an origin for this type of motif. Small bosses are also included in the ornament of other types of Pictish sculpture, for example the recumbent monuments Meigle XI and XXVI (op cit, Figs. 345B, 318A).

The elegantly carved panel on Kinnitty I C 9 is a relatively common pattern of interlocking 'C' scrolls; here, more unusually, it is placed three elements abreast. This pattern is precisely paralleled on Monasterboice West (Macalister 1946, P. XV.10) and there is another similar pattern on Durrow I D 9. The pattern in its simpler form is used extensively amongst the Ossory monuments (see p103) and there is a rather crude version on Graiguenamanagh I D 2 (see p195). Some of the stylistic features of Kinnitty I C 9, the triangular slashed expansions and the small spiral curlicues, are also found on Clonmacnoise IV C 2 (see p77). The pattern is also paralleled on some of the Pictish monuments, for example Shandwick (Allen and Anderson 1903, III, Fig. 66B) where the spirals are raised into bosses as are the spirals on Kinnitty I C 9.



The spiral patterns on Kinnitty I D 2 and Tihilly B 3 are similar and share the stylistic details of slashed expansions and small spiral curlicues with Kinnitty I C 8. The pattern on Kinnitty I B 3 is badly weathered but may be similar. These panels are paralleled on Clonmacnoise IV B 8 (see p 77).

On Tihilly D 3 the spiral pattern shows four registers of a double border pattern joined horizontally by 'C' scrolls and vertically by 'S' scrolls. This pattern is characteristic of the Clonmacnoise monuments being found on Bealin D 4, Banagher B 2 and D 2 and Clonmacnoise II A 1 (see p76). The small scale of the pattern, together with the leaf shaped 'S' scroll expansions may be compared particularly with the Banagher panels.

d) Fret Patterns

Patterns of this type are little used on these crosses. Tihilly C 6 is placed in a prominent position on the broad face of the shaft. The pattern, which is constructed on a diagonal grid using a unit

measure of approximately 5 cm, is not common. It is carved in low relief but the notches on the elements are cut somewhat deeper. The background to this pattern seems to lie in the large panels of interlocking  elements with each terminal ending in a straight line spiral found on Kilree C 9 and Killamery A 12 (see p135) but on Tully C 6 the scale of the pattern has become enlarged and the terminals are a mixture of ordinary spirals and notched straight line spirals. There are no precise parallels for this but there is a similar pattern with all the terminals ending in spirals raised into small bosses on the South side of Kells West (Roe 1966, Pl. XVIII). It may be more valuable to note that the practice of introducing ordinary spiral terminals into a fret pattern does not seem an early one. In Irish sculpture other examples are found amongst the 'Scripture' crosses, Monasterboice South and West for example (Macalister 1946, Fig. 13.61, Pl. XII North 4). There are further examples amongst the ninth century manuscripts, the Book of Armagh and the Book of MacDurnan (Allen and Anderson 1903, II, 345). There is a single example amongst the later Scottish monuments, the freestanding cross at Dupplin (op cit, Fig. 334D).

The pattern on Tully B 1, situated at the end of the horizontal cross arm, cannot be securely reconstructed but from what remains a square panel containing a single  element may be suggested. Both the use of single  elements, usually placed in rows, and the style of carving, the element being outlined in relief, are found on Clonmacnoise IV D 6 and Monasterboice South (Macalister 1946, Fig. 13, Panel 63). A similar pattern is used in an identical fashion on the cross-head fragment from Monasterboice (Roe 1954, Pl. X) and fret patterns are also found in this position on Monasterboice West, Clonmacnoise V and Durrow I (see p 246).

Kinnitty I D 4 is unique amongst the Irish sculptural fret patterns in that it is not laid out on the diagonal. The two straight line spiral elements have probably been used here to fit in with the taper of the shaft. There are no immediate parallels but straight line spiral patterns set on the diagonal are relatively common in both the sculptural and manuscript media (for example RA Nos. 965-971).

3) Scriptural Iconography

There are few figural panels on these monuments. However, they

are prominently placed on the crosshead and the broad faces of the shaft, thereby giving the appearance of dominating the decorative scheme of the crosses, although in fact they are very much in the minority. The subjects portrayed are few and they are all Scriptural: the Crucifixion (Kinnitty I A 1, Tihilly A 1, Drumcullin I A 1), the Fall (Kinnitty I C 7, Tihilly A 3) and two episodes from the David Cycle (Kinnitty I A 3). There are no examples of hunting or similar related scenes on these crosses. This is unusual considering the wide use of such iconography elsewhere in the Irish sculptural repertoire.

a) The Crucifixion

All three crosses have the Crucifixion on the crosshead. None of them are now in situ but it is very likely that this would originally have been placed on the west face. The placing of the Crucifixion on the crosshead rather than the top of the shaft (as in Kells South, Clonmacnoise IV and Killamery; see pp 86,146) groups these monuments with the large series of 'Scripture' crosses where figural scenes predominate (see p 210). On these the Crucifixion, where the monument is in situ, always appears on the west face.

The Crucifixion type on Kinnitty I and Tihilly, although not accompanied by other scenes from the Passion Cycle, may be closely compared with each other and with the Northern and Southern 'Scripture' crosses (see p 211). The only details which differ from Clonmacnoise V and Durrow I are that on Tihilly Christ's head does not tip slightly downwards towards the left. The head is also erect on the Market Cross, Kells (Roe 1966, Pl. XI) Durrow II, (see p 261), the Monasterboice fragments and Termonfechin (Roe 1954, Pls. X and XI). Also the hands are not enlarged and He does not stand on a Suppedaneum. A further feature on Tihilly, which is not found on Kinnitty I, is the figure at the end of the surviving horizontal cross arm. This is paralleled on Clonmacnoise V (see p 213). Neither Tihilly nor Kinnitty I include birds or angels, presumably owing to lack of space.

The Crucifixion scene on Drumcullin I has been further reduced to the figure of Christ alone. There is a small circular area on each side below Christ's armpit (Purser 1918, Fig a) which may be all that remains of the spear and sponge bearers. There are further bosses at the ends of the horizontal cross arms which probably act merely as fillers. This very simple version of the Crucifixion is paralleled on

the fragment from Monasterboice (Roe 1954, Fig. X A) and Graiguenamanagh II A 1 and C (see p190). On Durrow II (see p261) the spear and sponge bearers have been reduced to their heads only and there are spirals at the ends of the horizontal cross arms. However, unlike these the Christ on Drumcullin I may not be the Carolingian type clad in a loin cloth because there are traces of drapery below His neck. Similar drapery lines are also found on St. Mullins and Ullard A 2 and these could be crude versions of the complex folds of Christ's garment on Monasterboice West (Henry 1967, Pl. 87)(see p189).

b) The Fall

This is depicted on both Kinnitty I C 6 and Tihilly A 3 but the types represented are different.

Type I: On Kinnitty I Eve is shown handing Adam the apple. Adam is bearded. Similar versions of this are found on Durrow I B 10 (see p230) and Monasterboice South (Macalister 1946, Pl. V), although in the latter example Adam has not yet actually grasped the fruit. The cross base at Bray is perhaps a further example (Conway 1975, 54). On all three Cain and Abel are shown either as part of the same panel or in a separate panel elsewhere on the monument. On Kinnitty I it is shown in isolation.

Type II: On Tihilly A 3 a later episode in the story is shown. The monument is badly weathered at this point but seems to depict Adam and Eve covering themselves with their hands. This type is favoured by the sculptors of the Kells Crosses (Roe 1966, Pls. II, VII, XVII) and the Northern 'Scripture' crosses at Armagh, Arboe, Donaghmore and Killary (Roe 1955, 109; 1956, 82, 86; Crawford H.S. 1926a, Pl. I). It seems to be associated with scenes from the 'Help of God' cycle (see p121) although on Tihilly it stands alone. There is also an example of this type from Scotland, Iona II (Allen and Anderson 1903, III, Fig. 398A).⁴

The background to these images is discussed in Ch. X (see p230) but it may be significant to mention at this point that, although the Fall is depicted as an isolated event on Tihilly and Kinnitty I, it is associated to some extent with the Crucifixion. The head of Adam was represented from time to time in the Crucifixion iconography of the West

from the ninth century onwards and in some tenth century continental examples the Fall is represented immediately below the Crucifixion, the combination of the two images thus emphasizing the Redemption of fallen man through death upon the cross (Schiller 1972, 130-1, Pls. 390, 391, 370, 373). It is possible that this association may also have been in the minds of the Irish sculptors.

c) The David Cycle

J. Gleeson's interpretation (1915, 546) of the scene on Kinnitty I A 3 as showing the conversion of Aengus King of Munster is undoubtedly incorrect. Helen Roe (1949, 42, Fig. 1.6) has rightly seen it as showing two episodes from the David Cycle, David playing the harp and his anointing by Samuel. This combination of episodes is also found on Mal Lumkun, a Viking cross slab from Michael in the Isle of Man (Kermode 1907, 196, Pl. LIV) and probably on St. Martin's Cross, Iona (Allen and Anderson 1903, III, Fig. 397A).

David the harpist is a common representative in Irish sculpture either alone as amongst the Barrow Valley Crosses (see p194) or with accompanying musicians (see p222). Details such as the bird are paralleled on Monasterboice South (Macalister 1946, Pl. I) and the lyre type on Clonmacnoise V (see p223).

Samuel is represented as an ecclesiastic with a crozier which is not a feature of the other Irish representations of the anointing of David (Roe 1949, Fig. 1). His ecclesiastical garb may be compared with that worn by the figure on Clonmacnoise V C 15 (see p235). In addition he is not anointing David with a horn of oil but rather he holds a small situla in his upraised hand. The reason for this is unclear.

4) The Inscription on Kinnitty I

Traces of an inscription may be seen at the bottom of the shaft on Kinnitty I A 5. The inscription is in two lines and is incised. It is not easy to read but Professor Jackson (letter April 1978) has tentatively suggested:

OR . . ANMA
[E or O] NGUS

From this he has made two hypothetical reconstructions:

- 1) $\overline{\text{OR}}$ AR ANMAIN OENGUSO
'Pray for the Soul of Angus'
- 2) $\overline{\text{OR}}$ AR ANMAIN CONGUSO
'Pray for the Soul of Congus'

The inscription is very weathered and it is now impossible to be sure of the lettering and so it is impossible to verify these suggestions. No men of this name are connected with Kinnitty in the annalistic sources. The letter forms suggested to Jackson an eighth century date for the inscription which does not tie in with the rest of the ornamental repertoire and therefore it seems of little use as an aid to dating.

5) The Dating of the Monuments

From the foregoing discussion it may be seen that this small group of crosses have links with two other groups of sculpture, on the one hand with the 'Scripture' crosses, and on the other with the earlier monumental sculpture from Clonmacnoise. Comparison with metalwork and manuscripts have proved of little help in this instance.

The most important comparisons are to be made with the 'Scripture' crosses. Firstly it should be noted that on both Kinnitty I and Tihilly the practice of dividing the shafts into panels of decoration separated by picture frame mouldings is rigidly adhered to. This feature is not found on Kells South but is otherwise characteristic of the 'Scripture' crosses. However, the number of panels is limited to three or four rather than the greater number preferred on the more developed monuments of this series (see p253).

Secondly, it will be seen that the Crucifixion on Kinnitty I, Tihilly and Drumcullin I are placed on the crosshead as on all the 'Scripture' crosses except Kells South. The Christ type on Tihilly and Kinnitty I is also that found on the majority of the 'Scripture' crosses but again not on Kells South.

The use of panels and the Crucifixion type and placement would seem to suggest that Tihilly and Kinnitty I are a slightly later development than Kells South. However, all three monuments, Tihilly, Kinnitty I and Drumcullin I, have a spiral roundel at the centre of the crosshead

on Face C rather than an iconographical panel. A similar spiral roundel is also employed on Kells South and Duleek North and the use of small bosses in this context ties in with ninth century developments in Southern Pictland (Stevenson 1955, 121-3).

The ornament shows comparisons with both the 'Scripture' crosses and the earlier Clonmacnoise monuments. The interlace demonstrates close constructional links with Durrow I while the repertoire of ornament may be compared with the Clonmacnoise monuments particularly Clonmacnoise IV. Similarities in the spiral ornament with Kells South and Duleek North have already been noted; comparisons may also be made with the Clonmacnoise monuments. The zoomorphic and anthropomorphic ornament shows parallels with Kells South and Duleek North, the other 'Scripture' crosses and the Clonmacnoise group.

Therefore what one appears to have at Tihilly, Kinnitty I and Drumcullin I is a Southern development of the early 'Scripture' cross style which is initiated by the sculptors at Kells. Scriptural iconography has not entirely replaced the abstract ornament, the latter still remains in the majority, but has instead been adapted to occupy one or two important positions. Thus on these monuments it seems possible to detect the changeover point in the Irish Midlands between the groups of crosses where abstract ornament predominates, and the fully developed Southern 'Scripture' crosses Clonmacnoise V and Durrow I. A similar point can perhaps also be recognised with Duleek North and Termonfechin further to the north. (Roe 1954, 111-112).

The dating of these monuments is difficult but if Helen Roe's analysis (1966, 19-22) of the Crucifixion iconography on Kells South is correct (see p 87) it would suggest that monuments could be as late as the mid ninth century which would seem to place Tihilly, Kinnitty and Drumcullin during the latter half.

Chapter VIII FOOTNOTES

1. The only surviving documentary source is a Life of St. Finan written by a monk from Kinnitty (Kenney 1929, 421-2).
2. However, the more developed 'Scripture' crosses, Arboe and Monasterboice West for example, have a much greater number of shaft panels.
3. Attention should perhaps be drawn to the close similarity between the spiral patterns on Edzell and Kells South.

4. Also possibly Farnell (Allen and Anderson 1903, III, Fig. 232B).

Chapter IX GRANITE CROSSES FROM THE BARROW VALLEY

In the valley of the River Barrow in Co Kilkenny there are three crosses, Graiguenamanagh I and II and Ullard. In the past these crosses have been regarded as part of a larger group (Henry 1933, 165; 1940, 169, 173-7; 1965, 141-2; 1967, 134-5; Conway 1975) some of which are found outside the geographical area covered by this thesis. The crosses concerned are a base fragment from Bray, Castledermot North and South, Moone and a crosshead from the same site, Newtown, Old Kilcullen and St Mullins (Map IV).¹ In the Early Medieval Period all this territory was held by the Laigin (Mac Niocaill 1972, 35-6).

The main factor which groups these crosses is that they are all carved from the local granite. The hardness of the stone, which must cause chisels to blunt extremely quickly, is bound to affect the style and quality of the sculpture. In three cases, Ullard, Castledermot South and Newtown the cross appears unfinished and this could indicate that the sculptor lost patience with his difficult task. It may also account for the rather crude shape of some of these monuments. All the carving has been carried out with great economy. The field has been cut away leaving the figures and abstract ornament in low, sometimes rather flat relief. Very little attention is paid to detail except for the occasional incised line which is used to pick out a particular feature.

The aim of this chapter is to examine how Graiguenamanagh I and II and Ullard fit into the granite cross series and into the more general development of Irish sculpture.

Although the cross at Ullard is not now in situ it is thought to have originated from this site (Shearman 1874-5b, 507). The foundation under its original name of Erard is associated with St Fiacra (ibid), a figure perhaps better known in France since the place where he died c 670 near Meaux later became the site of the important monastery of Breuil (Kenney 1929, 490, 493). However the original locations of the two monuments now erected in the grounds of Duiske Abbey, Graiguenamanagh are more problematical. It seems likely that Graiguenamanagh I may also originate

from Ullard. Shearman (1874-5b, 507) mentions that a cross had been removed from there to Graiguenamanagh by the Rev. Mr. Braughal, perhaps in the early part of the nineteenth century. However, others (Kilannin and Duignan 1967, 302; Conway 1975, 125), probably following Galpin's rather vague reference to Graiguenamanagh I as the 'Ballyogan Cross' (1913, 13), have suggested that it originates from the ancient cemetery of Páirc an Teampaill at Ballyogan 2½ miles S.S.E. of Graiguenamanagh. Reasons for this suggestion seem to be lacking and therefore Shearman's ascription would seem more likely to be correct. Graiguenamanagh II probably originates from Aghailten near Ullard, a site associated with St Bairfionn (Shearman 1874-5b, 507). Shearman mentions that a cross was also moved by Braughal to Graiguenamanagh from this site and 'Aghailten' is actually inscribed on the modern base in which the monument is now erected. At any rate by the time O'Neill (1857, 3-4) saw them the two crosses had been inserted into the wall of the National schoolroom within the grounds of Duiske Abbey.

1) The Form and Layout of the Monuments

Graiguenamanagh I and II and Ullard all have Type IA crossheads (Fig 39), a variation of Type I, since the area between the line of the crosshead and the wheel has not been carved away. Newtown and St Mullin's also have this type. There is a small ridge on top of the upper cross arm on Graiguenamanagh I. Otherwise none of the granite crosses have any indication of a capstone.

Graiguenamanagh I Face A and the remaining part of Ullard Face A are divided into panels framed by roll mouldings, the majority decorated with figural iconography. Part of the height of the shaft of Graiguenamanagh I has also been lost and this may clearly be seen on A 8. It is difficult to tell whether the shaft was ever considerably longer but the division into three shaft panels may be compared with Castledermot North. In general a similar panelled layout is also found on many of the broad faces of the other granite crosses, for example the West face of Castledermot South. This type of layout may be compared with the 'Scripture' crosses where the emphasis on figural representation and the division of the carved face into panels are particularly characteristic (see p 203). However, in contrast with the 'Scripture' crosses, Graiguenamanagh I Face C is decorated with mainly abstract ornament and has not been divided into panels.

Abstract ornament is also used extensively on Graiguenamanagh Face A and Castledermot South, East face although on these the cross face is divided into panels. The narrow faces of Graiguenamanagh I are not divided into panels and are decorated with a continuous abstract pattern. This may be compared with Castledermot North and St Mullins amongst the granite crosses and also with Kilree and Killamery and to a lesser extent, with crosses in the Ossory group (see pp134,97). The narrow faces of Graiguenamanagh II and Ullard appear undecorated. This is also true of the Newtown fragment.

Graiguenamanagh I and Ullard have fairly tall bases of a truncated pyramidal shape with somewhat rounded corners. The proportions of these bases may be compared with Castledermot North which has a kind of upper step and it may be possible to compare this with the rather curiously shaped cross base from Moone.

It is easy to see that Graiguenamanagh II has been recut since there is now a Crucifixion on both broad faces. It is likely that the original Crucifixion is on Face A as by looking at Faces B and D it may be seen that the wheel arcs are flush with Face C while they do not extend right to the edge on Face A. This suggests that some earlier decoration may have been removed in order to carve the Crucifixion on Face C.

2) Figural Iconography

As far as the figural panels are identifiable on Graiguenamanagh I and II and Ullard they seem to be Scriptural. This is also true of the other granite crosses apart from Moone where the shaft is decorated mainly with animals and abstract ornament, the base with Scriptural scenes, and the Moone crosshead where animals predominate. It is difficult to tell whether many of the figural panels on Old Kilcullen are Scriptural or not. There are isolated hunting scenes on Bray and Castledermot South.²

It is the intention here to discuss in detail only the iconography which appears on Graiguenamanagh I and II and Ullard. The rest of the identifiable Scriptural iconography found on the granite crosses is summarised in tabular form in Fig. 32.

a) The Crucifixion

The Crucifixion is an important element of Scriptural Iconography amongst the granite crosses being found on all the surviving crossheads except the Moone fragment and possibly the Moone cross.³ This position may be compared with the majority of the 'Scripture' crosses and Kinnitty I and

Tihilly (see pp180,210).

Two different kinds of Crucifixion are found amongst the granite crosses, Christ in a robe and Christ in a loin cloth (Fig. 32). The robed type, which is found on Graiguenamanagh I and Ullard, is far more common. The diagnostic features are as follows: Christ is shown face on, His body and head erect, His eyes open. He is beardless and has short hair, which on Castledermot North, St Mullins and Newtown has become rather flattened so as to almost give the appearance of a hat or halo. He is dressed either in a knee length sleeved (?) tunic or an ankle length sleeved robe (Moone) sometimes belted (Castledermot South and North, St Mullins). Graiguenamanagh I and St Mullins show traces of a rounded collar, Graiguenamanagh I drapery folds and Graiguenamanagh I and Castledermot South a raised hem border. Christ is accompanied by the spear and sponge bearers; where identifiable (Moone and Castledermot North) Stephaton is on the right. On Moone and Graiguenamanagh I they are shown standing, on Ullard and Castledermot North and South they are seated on the rounded armpits of the cross and, owing to lack of space, on Newtown and St Mullins they have become reduced merely to small blobs of relief placed below Christ's arms. In all cases except Moone and Newtown there are two more figures above Christ's arms or head, probably angels, though on St Mullins these also have become reduced to small blobs.

This Crucifixion type depicting Christ in a tunic or long robe may be compared with Clonmacnoise IV A 2, Kells South (Roe 1966, Pl. IV) and Killamery A 10 (see pp86,146); also to some extent with Monasterboice West (Macalister 1946, Pl XVIII) although the Crucifixion here is much more complex. The main difference between the first three and the granite crosses apart from Moone is that the Crucifixion is placed at the top of the shaft on the West face rather than on the crosshead. A second difference is the identity of the two figures placed above Christ's arms. On Clonmacnoise IV A 2 and Kells South these may be Sol and Luna while those on Killamery A 10 seem to be angels holding a wreath. Amongst the granite crosses the figures appear most clearly on Castledermot South where they are shown face on with skirts and little wing flaps, thereby suggesting angels. They may be compared with angels in similar positions in Crucifixions in St Gall MS 61 (Schiller 1972, Fig. 349), the Athlone Crucifixion plaque (Henry 1965, Pl 46) and the Clonmacnoise Crucifixion plaque which Maire MacDermott has dated to approximately the tenth century (1954, 40, Pl. I).

Overall this type of Crucifixion amongst the granite crosses may be seen to fit into the general background of robed Crucifixions already discussed (see pp 86,146). With the exception of Moone, however, it is placed on the crosshead and therefore it would seem to be a slightly later development than those on Clonmacnoise A 2, Kells South and Killamery A 10. But, unlike the majority of the 'Scripture' crosses the Carolingian Christ is not introduced, but rather the more conservative robed Christ is retained.

It is interesting to note that Elizabeth Coatsworth (1979, 140-6) has suggested comparisons between the robed Crucifixions on the granite crosses and a rather crudely executed group of mainly robed Crucifixions centred on Yorkshire which may be dated broadly to the tenth century. The best parallel for the granite crosses is provided by Kirklevington I (Cleveland) which, as well as the robed figure of Christ Crucified with rounded shoulders and a rather flat head, has a similar crosshead form. However, there are no accompanying spear and sponge bearers or angels. Elizabeth Coatsworth has gone on to argue that this suggests artistic links between the Viking Kingdoms of York and Dublin in this period, Ireland being the giver and York the receiver.

The second Crucifixion type, Christ in a loin cloth, may only be identified on Graiguenamanagh II Face A. This, although considerably simplified since only the figure of Christ is shown, may be compared with the type found on the majority of the 'Scripture' crosses (see p210).

The Crucifixion on Graiguenamanagh II Face C is very crude and the type represented is unclear.

b) The Twelve Apostles

The twelve Apostles grouped in twos and threes are a characteristic feature of the granite crosses (Fig. 32). The identification of these figures as Apostles was first suggested by Margaret Stokes (1898, XIII) who reconstructed the fragmentary cross at St Mullins to show five pairs of Apostles beneath the Crucifixion (only one pair now survives) and the other two, of which one is still extant, on the horizontal cross arms. This seems perfectly plausible.⁴ On Castledermot North similar figures are grouped in three panels of three round the Crucifixion and on Moone they are shown in three rows of four on the base immediately below the Crucifixion. On Castledermot South they are placed in pairs on six panels which run the length of the south face of the shaft and on Old Kilcullen they are placed in three panels of four figures on the east face of the shaft. The fragmentary version on Ullard A 10 shows six figures in a

single panel and one suspects that the panel above, now missing may originally have been identical in order to make up the twelve.

The way in which these figures are carved is simple and repetitive. Apart from Old Kilcullen where the figures are rather thinner the principal features are a head, a rectangular body with square or rounded shoulders with two small feet sticking out at the bottom. There are sometimes one or two indications of clothing details but the upper limbs are not apparent. This may be compared with simplified figures in ornamental metalwork such as the Myklebostad and Løland bowl escutcheons found in Norway (Petersen 1940, Figs 108b, 96) and in manuscripts the figure of St Matthew, which is heavily influenced by metalworking traditions, in the Book of Durrow (f21v; Nordenfalk 1977, Pl 4).

A clue to the original format of scenes depicting the Twelve Apostles is provided by a panel at the top of the shaft on the east face of Arboe which represents Christ enthroned with His Apostles (Roe 1956, 82). Here eleven heads are shown in two rows of four and one row of three. Above are the busts of three figures. The central figure, Christ, holds a crook in His left hand and He blesses with His right. Helen Roe suggests the figures either side are likely to be angels. Christ and the Angels seem to have been lost on the granite crosses although on Castledermot South they could be misplaced in an unidentified panel immediately below the Crucifixion and on St Mullins they could be represented by the three figures above the Crucifixion.

The closest parallels for this scene are to be found in Hiberno-Saxon manuscripts. In the Turin University Library, MS O. IV.20 the Ascension page shows a roundel held up by angels. Inside is a bust of Christ holding a book in His left hand and blessing with His right. A small, full length angel is shown to either side (Henry 1974, Fig. 19). Below is another angel in a roundel and the busts of the Twelve Apostles shown face on or three quarter view. The Last Judgement page in the same manuscript shows Christ standing in the centre surrounded by a crowd of figures, all face on. Some figures are complete; others are cut off at the hip (Henry 1967, Pl 40). The Last Judgement in St Gall MS 51 shows a bust of Christ at the top, a book in His left hand, blessing with His right and with the Resurrection Cross under His arm. An angel stands on either side blowing a trumpet and below are the busts of Twelve Apostles, in two rows of six, each holding a book and looking skywards. (Henry 1974, Fig 21) (see p221). Iconographically one begins to wonder

whether the distinctions between the Last Judgement, the Ascension and Christ enthroned with His Apostles might not have become rather blurred amongst Hiberno-Saxon artists. A further connected element could be Christ sending out the Apostles as on Ahenny I A 7 (see p 116).

On a broader front the iconography of Christ enthroned with His Apostles has a long history. There is a fourth century wall painting from the Catacomb of Giordanus in Rome which shows Christ seated with six Apostles on either side (Beckwith 1979, Fig. 16). There is a similar late fourth century mosaic in the Chapel of S. Aquilino in S. Lorenzo in Milan (op cit, Fig. 15) and the subject is also depicted on a sarcophagus from S. Ambrogio, Milan of similar date (op cit, Fig. 30). There is a slightly later example on a mosaic in Santa Pudenziana, Rome (Gough, 1973, Fig. 69). A mosaic showing a bust of Christ in the attitude of blessing with a bust of an angel either side and below a line of standing Apostles and Saints with the Virgin Mary in the centre in the oratory of S. Veranzio in the Baptistery of S. Giovanni in Laterano, Rome dated 640-2 is another possible parallel. There do not seem to be any comparisons from the Carolingian period.

c) The Massacre of the Innocents

Ullard C 1 shows two figures with a third placed upside down between them. It may be compared with a similar panel placed in an identical position on Castledermot North, East face. Both Porter (1931, 123) and Helen Roe (1966, 39) suggested the Fall of Simon Magus was being represented but this seems unlikely as the figure on the left on Castledermot North undoubtedly holds a raised sword rather than a crozier which is being used as a weapon in the Fall of Simon Magus on the Market Cross, Kells (op cit, Pl XI). Also the positioning of the figure is incorrect as Peter and Paul are both shown to the right of Simon Magus not either side of him. Instead the most likely identification seems to be the Massacre of the Innocents, an isolated episode from a cycle illustrating the early life of Christ.⁵ Françoise Henry (1933, 144, Fig. 105) suggested there was also a version of the Massacre of the Innocents on Graiguenamanagh I. However, there is nothing on this cross which corresponds to her drawing.

The best parallel for Ullard C 1 and Castledermot North is provided by a shaft panel on the Market Cross, Kells which Porter (1931, 123, Fig. 262) identified as the Massacre of the Innocents. There is a further

parallel on Arboe (Roe 1956, 64). Françoise Henry (1933, 144, Fig 104; 1967, Fig. 20) has also suggested that three panels on Castledermot South, North face represent this episode but the composition is completely different. Parallels elsewhere are difficult to find. A fifth century diptych from Milan Cathedral Treasury (Volbach 1961, Pl 100) shows various scenes from the Life of Christ including the Massacre of the Innocents. Here a seated Herod with two flanking soldiers looks on as three soldiers conduct the massacre before him. One holds up a child in his left hand while he holds a sword in his right; a second child sprawls at his feet. Two weeping women, their arms outstretched, complete the scene. A later mid ninth century version may be seen on an ivory from Metz (Beckwith 1969, Pl 55). These have something in common with Castledermot South, especially the figure with outstretched arms. In this light it is possible that the two figures with upraised arms on Ullard C 3 could also represent the grieving women.

d) The Fall

This is found on Graiguenamanagh I A 6 and Ullard A 9 and is also popular amongst the other granite crosses (Fig. 32). It is frequently associated with the Sacrifice of Isaac (see p231) and on Bray and possibly Ullard A 1 with the Murder of Abel (see p230). The Fall iconography represented in all cases except Moone is Type I being comparable with Kinnitty I (see pl81) but on Graiguenamanagh I, Ullard and Castledermot North there is one important difference: Adam and Eve appear to be clothed. Why this feature should have been adopted is unclear and implies a misunderstanding of the entire story on the part of the sculptors. However, there is one possible explanation. In the early Middle Irish poem Saltair na Rann, a poem about the creation of Adam and Eve, the Temptation, the Fall and subsequent events based mainly on Apocryphal literature, at the point when Eve eats the apple her form changed 'and her raiment fell off her' (Seymour 1922, 122). This curious phrase suggests she may have been clothed before the Fall and it is possible that this is shown on these crosses.

e) The Sacrifice of Isaac

This is found on Graiguenamanagh I A 7, Ullard A 4 and elsewhere amongst the granite crosses on Castledermot North and South and Moone. On

Castledermot North and South and Ullard the panel is placed on the right hand horizontal cross arm. The complex symbolism of the Sacrifice of Isaac is discussed elsewhere (see pp121,23). The type represented is broadly the same as on the 'Scripture' crosses with one or two minor alterations. On Castledermot North and South and Moone, Isaac is shown bending forward over the altar. However, on Craiguenamanagh I this has become mangled to show him bending backwards under the altar while on Ullard he is actually seated on top of it. On Moone Abraham is shown seated. The ram is shown in each case but not the angel (see p232).

f) David Playing the Harp

This is found on Graiguenamanagh I A 8 and Ullard A 3. There are similar versions amongst the other granite crosses on Castledermot North and South. He is depicted without musicians and is shown playing a quadrangular harp (see p223). The scene is most likely to be an isolated episode from the David Cycle. However, Vincent Conway (1975, 76) has also made an interesting suggestion that since David is placed adjacent to the Crucifixion on Castledermot South and Ullard it could be a reference to a prophesy of the Crucifixion in Psalm 68 v. 22 'They gave me gall to eat and when I was thirsty they gave me vinegar to drink'. The closest comparison is provided by Kells South (Roe 1966, 14, Pl II) although there is no bird perched on the harp on the granite crosses. It would seem to fit into the same background as the more complex David and musicians scenes, probably being derived from Psalter illustrations (see p152).

g) Miscellaneous Iconography

The scenes on Ullard C 4 and Graiguenamanagh I C 1 and 7 are not identifiable. Graiguenamanagh I C 7 could show Jacob and the Angel (see p149) although the reason for the third figure is unclear.

h) Conclusions

The iconographic range on the granite crosses is not great and most scenes are repeated several times. No particular cycles of scenes are favoured but rather a somewhat miscellaneous assortment of unrelated subjects. The iconography on Old Kilcullen, mainly unidentifiable, does not really fit with the other monuments in the group.

The iconography on Ullard and Graiguenamanagh I is somewhat

fragmentary but seems to have had most in common with Castledermot North and South and the base of the Moone cross. Significant comparisons may be made between these crosses and the Scriptural iconography on the south and Market crosses, Kells and the more developed 'Scripture' cross from Arboe, Co Tyrone (Fig. 32). The iconography on these crosses is much broader and more complex but overall the comparisons are considerable.

3) Abstract Ornament

This is used quite extensively on Ullard and Graiguenamanagh I and II but the repertoire of patterns is small and their execution clumsy. This is not surprising if one considers the restrictions imposed on the sculptor by the hardness of the granite. The extensive use of constructional grids is also to be doubted since many of the patterns are extremely uneven and their simplicity suggests that little in the way of guidelines would have been necessary. Spirals, interlace and frets are all represented but there is no zoomorphic ornament.

a) Spirals

Two spiral patterns are found on Ullard and Graiguenamanagh I. There is no spiral ornament on Graiguenamanagh II. There are no other spiral pattern types found amongst the granite crosses.

The first pattern, which is very common, may be seen in its simplest form as a single border of 'S' scrolls on Castledermot North and South. Alternatively it may be elaborated and shown two, three or four rows abreast and joined horizontally as well as vertically by 'S' scrolls as on Ullard A 7 and A 13 and Graiguenamanagh I C 2; also Castledermot North and South and St Mullins. The possibly diagnostic feature of these spiral patterns is that circular or diamond shaped pellets are placed between the spirals as fillers. Although they may be present simply because it was easier not to carve away the entire granite field between the spirals, they could be chronologically significant since they are also characteristic of tenth and eleventh century Anglo-Scandinavian sculpture in Northern England (Stevenson 1956, 93-4; Bailey 1980, 180-1).

The second pattern, a double border of interlocking 'C' scrolls, found on Graiguenamanagh I D 2 is paralleled on Castledermot North and Kilkieran I C and there is a variation on Castledermot South.

b) Interlace

Interlace is used extensively on Graiguenamanagh II. The Half B pattern on Face A appears surprisingly competent and the evenness of the strands does suggest that a constructional grid may have been used. Half B is common in Irish sculpture, particularly on the Clonmacnoise monuments (see p51), but is not paralleled amongst the other granite crosses. In contrast the pattern on C 2 is very crude, being an impression of loops rather than a proper interlace pattern. It appears to be a copy of the pattern on Face A carried out by someone ignorant of the complexities of interlace.

The interlace on Graiguenamanagh I and Ullard is very simple. Firstly, on Graiguenamanagh I A 10 and Ullard A 11 and A 14 there are areas decorated with simple plaitwork meshes. Plaitwork is common on a lot of Irish sculpture (see p104) but amongst the granite crosses it is paralleled on Castledermot North, East face and St Mullins, North face. Secondly, there is a small grouping of Simple E elements on Ullard A 15 which may be compared with Killamery A 15 ii, also situated on the base. Lastly there is a pattern of interlocking semi circles (RA No. 766) on Graiguenamanagh I A 2 and B 3, Graiguenamanagh II C and a variation (RA No. 692) on Ullard A 16. It is also paralleled on Lorrha II C 1 (see p110). This motif is interesting as it is widely used on the late tenth century 'Samson' cross from Llantwit Major (Nash-Williams 1950, No. 222).

In addition there is another pattern on Castledermot North, South face which may be diagnostic. This twist and ring pattern which runs the length of the shaft is precisely paralleled on Killamery D 8 and is considered characteristic of the Viking repertoire of ornament (see p143).

c) Frets

Fret ornament is not found on either Ullard or Graiguenamanagh II. On Graiguenamanagh I A 9 is a pattern of \sqsubset elements set rather unusually on the square rather than the diagonal. This may be compared with a panel on Castledermot North and also with the ornament on the late tenth or early eleventh century font from Beaumaris (op cit, Pl XXX). There is also a very crude pattern of \sqsubset elements with spiralled terminals on Graiguenamanagh I B 2 which may be compared to some extent with the far more complex patterns on Kilree C 9 and Killamery A 12 (see p135).

In addition fret patterns are characteristic features of Castledermot South. The rather unusual \wedge element pattern on the East face of the shaft is paralleled on Clonmacnoise IV C 1 (see p80) and there are also a couple of examples from Wales at Llantwit Major and

Llangyfelach, Glamorgan (op cit, Nos. 212, 220, Pl LXVIII). There is another possibly diagnostic pattern of interlocking T elements on the wheel arcs of Castledermot North. It is interesting to note that this pattern is considered particularly characteristic of Anglo-Scandinavian sculpture in Northern England (Bailey 1980, 72).

d) Conclusions

The abstract ornament on Ullard and Graiguenamanagh I shows a similar repertoire to that on Castledermot North and South and St Mullins. However, it cannot be compared with the very different patterns found on Moone and Old Kilcullen. There are no close comparisons with ornament on other Irish crosses. However, a number of comparisons have been noted with ornament on the late crosses of Wales and Anglo-Scandinavian sculpture in Northern England. To what extent these parallels really exist is more difficult to be sure of since in both Wales and Northern England the patterns tend to be rather crudely executed and it may just have been that the sculptors chose similar simple patterns and took similar short cuts such as the use of pellets thereby creating a similar effect. However, perhaps not all these comparisons may be dismissed so lightly, particularly the twist and ring pattern on Castledermot North which is considered characteristically Viking.

The abstract ornament on Graiguenamanagh II is rather different but there are no close parallels.

4) Conclusions

The similarity of the iconography and the abstract ornament on Ullard and Graiguenamanagh I is clear and close comparisons may also be made with Castledermot North and South, Newtown and St Mullins. These monuments would seem to form the core of the granite cross group and may be termed the Barrow Valley crosses. Some iconographical parallels may also be made with the Moone and Bray cross bases. However, Old Kilcullen, the Moone crosshead and Graiguenamanagh II have little in common with the rest and are tied to the granite group by the stone from which they are carved rather than by ornamental parallels.

In the past the granite crosses have only been discussed in detail by Françoise Henry and more recently by Vincent Conway (1975). One gets the impression that Françoise Henry has always been rather unsure as to how they should be fitted into the development of Irish sculpture as

a whole. In 1933 (165) she rather tentatively ascribed them all to the ninth century. In her discussion she placed them after the Clonmacnoise group and before the Kells crosses. In 1940 (169, 173-7) she discussed their background in more detail and suggests that they are part of an early figural group dating to the ninth century. Amongst other crosses in this early group she included Kells South which she described as 'possibly the earliest' (op cit, 173). By 1965, however, her ideas had changed somewhat. Moone and Old Kilcullen have been pushed back into the eighth century and she sees the other granite crosses as carrying this style into the early ninth century (1965, 141-2; 1967, 134-5). She sees Castledermot North and South and Kells South as practically contemporary (op cit, 150). However, Conway's reassessment of the granite crosses suggested a completely different view. He was of the opinion (1975, 101) that, unlike the other groups of Irish crosses, these were made over a period of at least one hundred years. He saw Moone as early to mid ninth century and before Kells South, Old Kilcullen as late ninth or early tenth century and the Barrow Valley crosses as c900-950 beginning with Castledermot North and South and grinding to a degenerate halt with St Mullins (op cit, 49, 75, 92-3).

It seems difficult to agree wholeheartedly with either of these views. The crosses at Castledermot must have been carved after the foundation of the monastery in 812 (A.1.812) but otherwise one is thrust back entirely on art historical criteria. In order to attempt to date the Barrow Valley crosses it seems essential to understand their relationship to Kells South. This monument is generally considered the initiator of the 'Scripture' cross series (see p 253) and as such an innovation (Henry 1940, 173-5). The iconographical parallels between the Barrow Valley crosses and the South and Market Crosses, Kells have already been noted (Fig. 32). The former would seem to be the receiver since on the Kells crosses it is possible to catch a glimpse of the models from which the figural panels were derived. This is completely impossible on the Barrow Valley crosses since the scenes are much simplified and sometimes misunderstood and the style of carving clearly betrays its Hiberno-Saxon background. The position of the Crucifixion on the crosshead of the Barrow Valley crosses and their frequent division into panels also suggests that they are later than Kells South. However, the comparatively narrow range of iconography leads one to suspect that they were carved before the more complex 'Scripture' crosses such as Monasterboice South and Arboe

were executed (see p253). Elsewhere (see p 87) it has been argued that Kells South could date to the mid ninth century. It therefore seems likely that the Barrow Valley crosses could date to the second half of the ninth century. One suspects that they may have been carved over a fairly short period, perhaps only a few years. They are very similar and could have been executed by one or two sculptors although it is not now possible to suggest the same hand on more than one monument. It also seems likely that the impetus for the group came from Castledermot, a monastery of known importance during the second half of the ninth century (Flower 1954, 93) since these crosses show the greatest variety of iconography and ornament, the rest being much less accomplished.

A date during the second half of the ninth century would also support the idea that the Barrow Valley crosses may have influenced the development of Anglo-Scandinavian sculpture in Northern England since, during the later ninth and the first half of the tenth century, there are extensive contacts between the Viking Kingdoms of Dublin and York and in the early tenth century there is the settlement of the Hiberno-Norse in North West England (Smyth 1975). Richard Bailey (1980, 229-31) is right to have pointed out the serious difficulties in the widely held view that Irish art influenced Viking stone carving in Northern England since the Irish did not adopt Viking art styles until the eleventh century (Appendix 2) and since most of the iconography which is thought to be Irish can in fact be paralleled in Northern England at an earlier date. However, several comparisons in the ornamental repertoire including the robed Crucifixion have already been pointed out between the Barrow Valley crosses and those in Northern England, enough perhaps to suggest more than a mere coincidence. In this light it is interesting to note that the only hogback so far identified in Ireland is from Castledermot (Lang 1971).

Graiguenamanagh II is very crude and therefore extremely difficult to date. The adoption of the Crucifixion type showing Christ in a loin cloth on Face A could suggest it is slightly later than the other crosses from the Barrow Valley. Since the recutting of Face C seems to be a crude copy of the carving on Face A it could have been carried out at almost any date.

Moone, the Moone crosshead and Old Kilcullen are all ~~rather~~ unique and since Bray is fragmentary they are all very difficult to date. Because of the apparent influence of the Kells crosses on the iconography of Moone

it is unlikely to be as early as the late eighth century. However, both Moone and Old Kilcullen would undoubtedly repay a more detailed study.

Ch. IX. FOOTNOTES

1. Photographs of these crosses are to be found in the following places:-

Bray: Henry 1933, Pl 97.1 and .6; Conway 1975, 54-5.

Castledermot North: Henry 1933, Pl 48; 1964, Pls 22b, 24; 1967, Pls. 68-72.

Castledermot South: Henry 1933, Pls 46, 47.1; 1964, Pls 19, 21, 22a, 23; 1967, Pls 65-7.

Moone: Henry 1933, Pls 44-5; 1964, Pls 12, 13b, 14-6, 17b; 1965, Pls 68, 70-2, 81.

Moone crosshead: Henry 1933, Pl 42.

Newtown: No published photographs

Old Kilcullen: Henry 1933, Pl 43; 1964, Pl 18; 1965, Pls 73-4.

St. Mullins: Henry 1933, Pls 49.1, 50.1

2. Compare with similar base panel on Kells South (Roe 1966, Pl II).
3. There is some confusion over the Crucifixion on Moone. There is a robed Crucifixion in an unusual position on the base of the West face. In addition there is also a figure with outstretched arms on the cross-head of the East face. The figure has no other attributes and therefore it is impossible to tell whether a second Crucifixion is intended though perhaps Christ in Glory may be more likely.
4. For the importance of the 'plan' in the Book of Mulling and its possible relevance to this cross see p39 and Appendix 1.
5. A related scene is the Death of Isaiah as shown on the crosshead from Winwick in Cheshire (Bailey 1980, 159-61, Fig 39). Isaiah is held upside down between two figures and is being sawn in half. Richard Bailey suggests that this iconography may be influenced by depictions of the Massacre of the Innocents. There are no indications of a sword on Ullard or Castledermot North.

Chapter X. CLONMACNOISE V AND DURROW I

These monuments are two of the most accomplished examples of a large group of crosses which are decorated mainly with figural scenes of a Scriptural nature and are therefore commonly termed 'Scripture' crosses. However, these are southern outliers of a group which has a predominantly Northern distribution centring on the Boyne Valley and the province of Ulster (Map IV).

The monastery of Durrow or Dair-mag meaning 'oakplain', situated in the territory of the Southern Uí Néill, is an important monastery throughout the Early Christian Period. Founded in 551 by St. Columcille it may be seen together with Derry, Iona and later Kells as one of the major establishments of the Columbean paruchia (Kenney 1929, 424). The monastic 'city' was sited adjacent to the main east/west land route (Hughes and Hamlin 1977, Fig. 2) and clearly this would have greatly facilitated communication with the outside world. However, very little now survives of either the Columban foundation or the twelfth century Augustinian abbey. The Early Christian remains are confined to three examples of monumental sculpture (Durrow I, II, III), two of which are now missing (see Ch. XI (3)(4)), and five examples of early grave slabs which stylistically have much in common with those at Clonmacnoise. In addition the present early eighteenth century church, now derelict, may incorporate earlier fabric (Killanin and Duignan 1967, 448).

Clonmacnoise V may be seen, together with the great number of more mundane grave slabs belonging to the ninth and tenth centuries (Macalister 1909) as testifying to the continuing importance of Clonmacnoise as a centre of sculptural patronage (see Ch. IV). As Kathleen Hughes (1958, 247-8) has shown the scriptorium at Clonmacnoise in this period also indicates the importance of artistic pursuits. Her study of the annalistic sources revealed that by the end of the tenth century only two monasteries, Armagh and Clonmacnoise, were still recording the obits of both 'scribes' and 'lectors'. Politically

Clonmacnoise seems to have overcome the worst of the mid ninth century Viking onslaught¹ and turned its sphere of influence from Connaught towards Meath. The documentary sources record links with the Meath Kings, first Mael-Sechnaill I and later with his son Flann (obit 916) (Hughes 1966, 219). Indeed the Chronicon Scottorum records that in 908 Flann, with the help of Abbot Colmán, built a stone church at Clonmacnoise.² In addition these two figures have also been credited with the erection of Clonmacnoise V. This will be discussed in some detail at the end of the chapter.

It has also been suggested that this cross has other links with the annalistic sources (Macalister 1909, 153; Westropp 1907a, 290). Firstly it has been associated with the 'crois aird' marking the limits of devastation of a raid on the monastery³ and secondly with the 'cross na screaptra', a monument indicating a place of sanctuary.⁴ These associations of which the latter has led Clonmacnoise V to be called the 'Cross of Scriptures' are thoroughly misleading as it cannot possibly be proved that the annalists had the same monument in mind. This term has therefore been dropped.

1) The Form of the Monuments

Overall, these two monuments have broadly similar proportions, Durrow I being on a slightly smaller scale. Both are monolithic and the upper cross arm terminates in a roof shape rather than a separate capstone. In this they may be seen to differ from all the Northern 'Scripture' crosses where the capstone is separate and in some instances, for example Monasterboice West and Arboe (Macalister 1946, Pl. XII; Roe 1956, Pl. 1), the shaft and crosshead are also made up of more than one piece. The fact that the capstone is not conceived as a separate house shape may be influenced by monuments like Clonmacnoise IV and Killamery which do not have complete house shaped capstones but rather roof shaped ones. Clonmacnoise V and Durrow I give the impression of having had roof shaped capstones fused with the upper cross arms. However, their 'regulated roofs', which may be compared with the house-shaped capstones of the Northern 'Scripture' crosses, are a distinctive feature and in addition, like Monasterboice South, Durrow I displays striking use of zoomorphic gable finials which, as Leask (1955, 46-7) has suggested, probably show the influence of timber construction

techniques. The additional influence of metalwork house-shrines has already been suggested (see p 38).

The crossheads of the two monuments differ. Durrow I (Type IV) (Fig. 39) has only one close comparison, Arboe, Co Tyrone (Roe 1956, Pl. 1) but the wheel is of the usual type. In contrast the crosshead (Type V) of Clonmacnoise V is unique. Here the wheel is projected over the crossarms thereby creating an unbroken circle which dominates the crosshead. This circle has the appearance of being kept in place by four flat plates positioned at the junctions of the wheel and the crossarms. This, combined with intricate zoomorphic interlace and bossed spirals, perhaps indicates the influence of metalworking techniques. A second feature which draws attention to the unusual design employed by the sculptor is the fact that the cross arms within the wheel are very narrow; outside they become broader and the horizontal cross arms have a distinctly upward tilt. The closest Irish parallel is provided by Templeneiry I (see p270), where the ring is also projected over the cross arms, but in this instance the wheel is solid and the width of the cross arms is consistent. In Britain Richard Bailey (1980, 177-82) has isolated a group of Viking period crosses with 'circle heads' which have a west coast distribution centring on Cumbria and Cheshire. The wheel is comparable with Clonmacnoise V but otherwise the ornament is dissimilar. However, the crossheads of Clonmacnoise V and Durrow II also have two factors in common. Firstly, they both have rolls positioned on the inside edge of the wheel arcs. The more usual position for these rolls amongst the Northern 'Scripture' crosses is at the intersections of the cross arms (e.g. Kells South Roe 1966, Pl. V) but their placement on the wheelarcs on Clonmacnoise V and Durrow I is paralleled on a number of Ulster crosses at Armagh, Arboe, ^{Co} and Donaghmore, ~~and~~ Tyrone (Henry 1964, Pl. 36; Roe 1956, Pls. I, X; 1955, Pl. XI). Secondly, they both have embellished perimeter mouldings at the ends of the horizontal cross arms on the broad faces. On the narrow faces these become horizontal rolls stretching along the tops and bottoms of the panels which, in addition, have a faceted appearance. These features, together with the fretwork ornament on the panels at the end of the horizontal cross arms, are paralleled on Monasterboice West (Macalister 1946, Pl. XII).

On both Clonmacnoise V and Durrow I each face of the shaft is divided into three panels with a butt at the base. Monasterboice South

has three panels on three faces, four on the fourth. The small north cross at Duleek also has three panels (Henry 1967, Pl. 103) but otherwise the Northern 'Scripture' crosses tend to have four or more, the number seeming to increase on the more developed monuments; for example Monasterboice West has eight panels on the east face of the shaft. The heights of shaft panels on Clonmacnoise V are fairly consistent, the majority being around 43 cm. Those on Durrow I are rather smaller and have greater variation in size but a number do average out at around 35 cm. in height. Like Tihilly and Kinnitty I (see 171) and many of the Northern 'Scripture' crosses the perimeter roll mouldings on the shaft make use of areas of horizontal banding and there are also vertical breaks in the picture frame mouldings.

Compared with Clonmacnoise IV and the Ossory crosses the importance of the base on Clonmacnoise V and Durrow I is much less. The usual truncated pyramidal shape is adopted but on Clonmacnoise V the scale of the figural carving on the base is smaller than on the rest of the monument. On Durrow I the base, which has three steps, is divided into panels with the aid of mouldings but is otherwise undecorated. This lack of decoration but use of mouldings may be closely paralleled with Monasterboice West (Henry 1967, Pl. 86). Other examples, where the bases are left completely undecorated, are Arboe, Galloon East and West and Lisnaskea, Co Fermanagh (Roe 1956, 81; Lowry-Corry 1934, 168, 170; 1935, 153-4).

Therefore, apart from the unusual emphasis on the wheel on the crosshead of Clonmacnoise V, Durrow I and Clonmacnoise V are similar in form, and may be compared with the Northern 'Scripture' crosses. One or two features have close affinities with Monasterboice South but many more find their closest parallels with Monasterboice West and some of the other Ulster crosses, particularly Arboe.

2) The Layout of the Monuments

Clearly the figural iconography completely dominates the layout of both crosses. The abstract ornament, apart from Durrow I C 8, plays very much a secondary role, being found almost exclusively on the narrow faces, the upper cross arms and the wheelarcs. It is likely that the emergence of figural iconography as the major cross ornament may be seen first on the South Cross, Kells where a great variety of

Biblical scenes are prominently displayed between areas of abstract ornament without resort to the placement of the different motives in separate panels. This theme is gradually developed with an increasing emphasis on the iconography and the addition of panels on the Market Cross, Kells and becomes the hallmark of the Northern 'Scripture' crosses. The predominance of figural iconography is also found on the Barrow Valley Crosses (Ch. IX) and their more northerly granite counterparts at Moone and Old Kilcullen.

3) The Figural Panels

A wide variety of iconography, both Biblical and otherwise, is found on Clonmacnoise V and Durrow I. Some panels seem to be complete in themselves; others appear to form a close grouping, depicting either a story or a cycle of events.

The figure carving on both monuments is extremely accomplished. The figures are conceived on a large scale and in high rounded relief. The impression thus given is three dimensional. This feeling is increased by the fact that the heads of many of the figures have been slightly undercut and therefore stand right away from the façade of the monument. The sculptors have tackled faces in profile, face on, and, more unusual, three quarter view. There is also great attention to detail, particularly that of dress, vestment types, brooches, embroidered hems etc. One would also expect other details to have been brought out with the aid of paint although no physical traces of this have survived.

a) The Passion Cycle and Related Iconography

Scenes from the Passion dominate the Western face of both Clonmacnoise V and Durrow I. A similar dominance may be traced on the Western faces of Monasterboice South and West. A number of Passion scenes are also depicted on other Northern 'Scripture' crosses. Their occurrence may best be summarised in the following table:

Cross	Scene	Entry into Jerusalem	Kiss of Judas	Arrest, seizing and binding scenes	Peter with sword	Denial of Peter	Pilate washing hands	Flagellation	Mocking	Crowning with thorns	Crucifixion	Soldiers guarding tomb	Three Marys	Traditio Legis
Clonmacnoise V				✓?							✓	✓	✓	✓
Durrow I		?		✓?		?	?				✓	✓		✓
Arboe	✓			?							✓			
Armagh				?							✓			
Castledermot South				?							✓			
Donaghmore				?							✓			
Galloon West				?										
Kells Market				?							✓	✓		
Kells West	✓													
Monasterboice South	?			✓			✓	✓			✓	✓	✓	✓
Monasterboice West			✓	✓?	?				✓	✓	✓	✓		?
Templeneiry I				✓										

Fig. 33

✓ Firm identification

? Possible identification

The Entry into Jerusalem. It is possible that the badly weathered panel depicting a horseman on Durrow I B 2 may represent this scene. The reason for suggesting this is provided by a panel on Monasterboice South which is placed in an identical position. This shows a figure mounted on a horse or mule. He is shown in profile facing left. Above him are angels and there is also a small figure placed just above the horse's rump (Macalister 1946, Pl. XI, 43). Helen Roe (1954, 105) has suggested that this could represent the Entry into Jerusalem and this seems reasonable considering the large number of other Passion scenes on this cross. The Entry into Jerusalem may also be recognized

on Kells West and Arboe (Henry 1967, Figs. 31-2). On these Christ is shown in profile facing right and this would seem to be the more usual direction amongst examples on the Continent. Parallels are not easy to suggest since Carolingian and earlier Late Classical versions (Schiller 1972, Pls. 31, 33-9) show much more complex scenes with crowds and an architectural background. However, in the Irish examples space was limited so little more than the figure of Christ seems to have been attempted. Perhaps a closer parallel for the Monasterboice scene is provided by the mid sixth century depiction on the throne of Maximian, Ravenna (op cit, Pl. 32). Here Christ riding an ass dominates the panel. Above Him are the busts of two figures bearing palms. It seems possible that on the Monasterboice scene the palm bearers have become misunderstood and turned into angels.

The Arrest of Christ and Related Scenes. The Kiss of Judas is only found once amongst the surviving Irish sculpture, on Monasterboice West (Macalister 1946, 51). However, scenes showing Christ being held by two figures, sometimes in military dress or armed, are found on many of the 'Scripture' crosses including Durrow I A 9 and 10 and Clonmacnoise V A 13 and A 14. In many instances confusion has arisen because more than one arrest scene seems to be depicted on a single monument. For example, Porter (1931, 42, 52) identified Clonmacnoise V A 13 as showing Columcille sent into exile, a very unlikely subject considering that Clonmacnoise was not part of the Columban paruchia and Durrow A 9 as the Old Testament episode concerning Moses, Aaron and Hur (Exodus XVII, 8-13). The latter story, which describes Aaron and Hur supporting Moses' outstretched arms during the battle between the Israelites and the Amalekites and is undoubtedly a prefiguration of the Crucifixion (Schiller 1972, 90), may be identified with some confidence on Monasterboice South (Macalister 1946, 43, Pl. 42) but there seems no need to suggest it in the case of Durrow A 9. It seems more likely on both Durrow I and Clonmacnoise V that one is dealing with two scenes from the Passion Cycle where Christ is being seized or held. There are a number of incidents on both the late Roman sarcophagi and Carolingian ivories other than the actual seizure where Christ is shown between two captors. These are when He is being bound immediately after capture, when He is brought before both Caiaphas and Pilate and when he is being led away from Pilate (Schiller 1972, Pls. 165, 166, 2,

10, 11). In this light it would seem more appropriate to identify Durrow I A 9 with the arrest while A 10 and Clonmacnoise V A 14 show Him being bound. Clonmacnoise V A 13 has an odd appearance since the central figure seems rather disjointed and the soldiers touch rather than hold him but the arrest seems a probable identification although the sculptor may not have entirely understood his model.

On Durrow I A 9 a youthful Christ is shown between two soldiers carrying raised swords. This may be compared quite closely with the version on Monasterboice South (Macalister 1946, Pl. VII, 21). On Clonmacnoise V A 13 the captors are shown with spears and this is paralleled on possible versions on Monasterboice West and Donaghmore (op cit, Pl. XVII, 7; Roe 1956, 86). The fact that the captors are armed is unusual. In the Book of Kells (f114R; Henry 1974, 188-9) a bearded Christ, His arms raised is shown being held by two very much smaller figures to either side and unarmed figures are also depicted in the St. Augustine Gospels (Cambridge, Corpus Christi College M.S. 286, f125) illuminated in Italy c 600 (Wormauld 1954, Pl. I). However, a parallel tradition of armed captors does seem to have existed elsewhere as the Khudolov Psalter, illuminated in the second half of the ninth century in Constantinople, shows a bearded Christ between a man with a raised stick and a second carrying a shield and sword (Schiller 1972, Pl. 162).

Durrow I A 10 and Clonmacnoise V A 14 have been identified above as the Binding of Christ. In each case Christ is shown held from behind by the right hand captor while that on the left appears to grasp His hands. Porter (1931, 52) actually suggests that one of the captors on the Durrow version is holding a rope but the weathering is such that this seems impossible to be sure of. It is interesting that the binding of Christ is also stressed amongst some of the Late Carolingian ivories. For example, He is shown being grasped from behind and led away on an ivory from the Metz school dated c 850. The drapery lines on Christ's robe may be closely paralleled with Irish examples (Schiller 1972, 52-3, Pl. 165).

Incidentally, it is rather peculiar that the Clonmacnoise V scenes show the soldiers as well as Christ with halos. This either implies a mistake or misunderstanding on the part of the sculptor or an error in his model.

The Denial of Peter It seems possible that the scene on Durrow I A 3, as Porter (1931, 57) has suggested, may depict the Denial of Peter. This identification can only be very tentative since, if it is correct, it has become very distorted. This is partly due to its position at the end of the horizontal cross arm but a certain amount of misunderstanding of the story is also implied on the part of the sculptor. The left hand figure may be Peter seated in a chair. He holds a drinking horn, for which there is no parallel, in his right hand. On his left appears to perch a bird which may be identified with the cock. The second figure is suggestive of the maidservant who is turned away from Peter in order to fit the scene into the limited space. The reasons for thinking that the Denial of Peter may be intended are firstly that the rest of the west face seems to concentrate on the Passion Cycle and that this scene balances the probable representation of Pilate washing his hands on A 4. The Denial of Peter happens chronologically immediately before Pilate washing his hands. Secondly, it seems difficult to suggest a meaning other than the cock for the bird. Birds are sometimes shown with David playing the harp (see Kinnitty I A 3) but this scene is already depicted on Durrow I C 3. However, the meaning of the drinking horn is a puzzle and perhaps the possibility should not be ruled out that this is a misplaced part of the David and Musicians scene on the other side of the crosshead (see p222).

If the identification of the Denial of Peter is correct it is the only known example on the Irish crosses. Nor can any helpful parallels be cited from other sources.

Pilate Washing his Hands This scene may be identified without doubt on Monasterboice South (Macaliser 1946, Pl. XI, 38). Here Pilate is shown in profile facing right. He has long hair, a beard and is dressed in long robes. He stretches his hands out towards a figure who is standing facing him. This figure holds a ladle in his right hand which he lifts to tip water over Pilate's hands. He holds a roundish object, a bowl (?), or cloth (?) in his left hand. A further object, a bowl (?) is set in mid air between them. Above and behind are shown three guards, face on and armed with spears and shields. Porter (1931, 57, 124) suggested that the same identification could be made for Durrow I A 4.⁵ The Durrow scene is both severely weathered and somewhat mangled, since it has been adapted to fit into the awkward shape of the horizontal

cross arm, but Pilate washing his hands seems a reasonable suggestion. The scene has been reduced to two figures; Pilate on the right is seated. He stretches his hands towards the second figure who, owing to lack of space, has now been bent into a seated position. The second figure holds a ladle and a stream of water, shown by a line in relief, falls onto Pilate's hands.

There is a long tradition of showing Pilate washing his hands both as a single scene representing the entire Passion and as an integral part of the Passion Cycle (Schiller 1972, 64). It is more usual as on Monasterboice South to show Pilate with one or more attendants as well as the servant but there are examples (op cit, Pls. 205, 276) as on Durrow I where the scene has been contracted into merely Pilate and the servant. The closest parallel for both is provided by the Gospels of St. Augustine (Cambridge, Corpus Christi Coll. MS 286, f125) (Wormauld 1954, Pls I, VI). Here Christ is shown on the right of the scene being led away between two soldiers. On the left Pilate is shown seated. He stretches his hands towards the servant who holds a ladle rather than the more usual jug in his right hand and a cloth in his left.

The Crucifixion In some instances on Irish sculpture, Clonmacnoise IV, or the Barrow Valley Crosses for example (see pp86,188), the Crucifixion appears in isolation but on both Clonmacnoise V and Durrow I it may be seen as an integral part of the Passion Cycle. However, from its position on the crosshead of the west face it is undoubtedly the most important episode shown. As has already been demonstrated (see p 86) early examples of the Crucifixion on the high crosses are rare and are not placed on the crosshead. But, with the increase in popularity of figural subjects, the Crucifixion moves onto the crosshead and its cruciform shape actually represents the cross to which Christ is nailed. This position is paralleled on all the Northern 'Scripture' crosses, the Barrow Valley group, Durrow II and also at Tihilly, Kinnitty I and Drumcullin. It is interesting to note that Elizabeth Coatsworth (1979, 200-1) has traced a similar development in the sculptural representation of the Crucifixion in Anglo-Saxon England where early examples are both rare and not positioned on the crosshead. The fragmentary cross from Rothbury, which she dates to the mid ninth century, is the earliest example of the Crucifixion in this

position.

The Crucifixions on Clonmacnoise V and Durrow I are almost identical. The crossheads are relatively small and so the area available for sculptural embellishment is severely restricted. Therefore the scene is reduced to the bare essentials. The diagnostic features are as follows: Christ is shown erect, face on, beardless and perhaps with traces of a loin cloth or perizonium. It is not possible to see whether the eyes are open but from the erect position a living Christ may be assumed. His head tips slightly downwards towards the left. The hands are enlarged and the thumb is set close to the fingers. The hands and arms do not droop. His feet face outwards and are bound with rope. They rest on a suppedaneum although on Durrow I this has become an interlace filler. Christ is accompanied by the spear and sponge bearers, Longinus to the left, Stephaton to the right. They have been squashed into kneeling or crouching positions because of the very limited space. There are also some minor differences between the representations. Firstly, on Clonmacnoise V the bust of an angel is placed behind Christ's head. Secondly, on Durrow I a bird is placed above Christ's head; on Clonmacnoise V this is placed below the Crucifixion on one of the plaques on the wheel, A 12. Thirdly, Clonmacnoise V has figures with staffs on the ends of the horizontal cross arms; as has been demonstrated Durrow I probably shows other scenes from the Passion Cycle in this position.

This way of representing Christ as young, beardless and living, His body erect and either naked or clad in a loin cloth is the most usual form found amongst the Northern 'Scripture' crosses. However, there are some exceptions: on Kells South and Armagh Christ is clad in a tunic while on Monasterboice West and Donaghmore He is dressed in a long robe with sleeves (Roe 1966, Pl. IV; 1955, 110, Pl. XI; 1956, 86). Tihilly and Kinnitty I also show Christ naked or in a loin cloth. In metalwork Christ in a loin cloth may be seen on two Crucifixion plaques, one from Dungannon, the other with no location (Mahr 1932, Pls. 29.11, 50.8). The detail of Christ's head tipping slightly towards the left is paralleled on Monasterboice West, Duleek North and Kinnitty I.

This Christ type is clearly derived from ninth century Carolingian prototypes, probably found on ivories or metalwork or in manuscripts (Schiller 1972, 104). The closest parallels are provided by an ivory book cover associated with the Court school of Charlemagne and dated to

the early ninth century, the Nicasius Ivory Diptych from Tournai dated c 900 (op cit, Pls. 368, 367) and in metalwork the Book Cover of the Lindau Gospels dated c 870 (Lasko 1972, 65-6, Pl. 59). All include the detail of Christ's head tipping slightly towards the left. However, these all show Christ's feet nailed to the cross whereas in Ireland He is shown bound with rope. This feature seems to be particularly Irish and there do not seem to be any parallels for it.

In Ireland this version of Christ crucified is without exception accompanied by Longinus and Stephaton but the expanded Crucifixion image adopted by Carolingian artists (Schiller 1972, 107-117) is not found. The reasoning behind this may be linked with the lack of space available on the crosshead for extra figures. However, one should also bear in mind the conservative nature of the Irish Crucifixion which seems to show Longinus and Stephaton from an early date usually with angels placed either side of Christ's head, for example the Athlone Crucifixion Plaque (Henry 1965, Pl. 46) (see p 87). This, with or without the angels and with a wider variety of Christ types and sometimes with the addition of the thieves, for example on Armagh (Roe 1955, Pl. XI), or perhaps Sol and Luna (see p 87) or figures with staffs on the horizontal cross arms remains the standard type until the introduction of a new long robed Christ in the early twelfth century (Schiller 1972, 144).

On Clonmacnoise V one angel is shown immediately above Christ's head. It may have been placed here due to lack of space above Christ's arms and therefore may be a continuation of the use of angels to emphasise the deity of Christ found amongst earlier Irish crucifixions, for example the Athlone Crucifixion Plaque (Henry 1965, Pl. 46). However, it could also be derived from the next stage in the development of this motif, a popular Carolingian representation which shows angels hovering around Christ's head as on the mid ninth century ivory relief forming the cover to the Book of Pericopes of Henry II (Schiller 1972, 108, Pl. 365). The closest parallels for the Clonmacnoise angel are provided by the cross at Termonfechin (Roe 1954, Pl. XI) where a full length angel is shown and by a rather cartoon-like Crucifixion page in the Southampton Psalter (St. John's Coll., Cambridge, MS C.9), where, as well as angels placed above the horizontal cross arms, there is also the bust of an angel placed immediately above Christ's head. Françoise Henry (1960, 34, Pl. XIII) dates the manuscript to the

second half of the tenth century or the beginning of the eleventh.

On Durrow I a bird appears above Christ's head and on Clonmacnoise V there is a bird, which looks very like a dove, placed below the Crucifixion on one of the plaques on the wheel. A bird appears above Christ's head in the Crucifixion on Kells South (Roe 1966, Pl. IV). Here it is not part of the Crucifixion scene but rather an eagle, the symbol of St. John, one of the four evangelist symbols which surround the figure of Christ in Majesty placed at the centre of the crosshead. It seems likely that, due to a misunderstanding, this bird has actually been incorporated into the Crucifixion on some of the later crosses. As well as Clonmacnoise V and Durrow I a bird is also positioned at the feet of the Crucified Christ on both Monasterboice South and West and above His head on Durrow II (see 261). However, perhaps the possibility should not be ruled out that this bird is a dove representing the Holy Ghost. In Carolingian Crucifixion iconography the first surviving example of a dove as part of the scene is shown on the Cross of Lothar c 880 where the Manus Dei may be seen holding a victory wreath encircling a dove and in twelfth century Germany the dove is also included in representations of the Throne of Grace (Schiller 1972, 108, Pls. 395, 412-4). The idea that the bird may personify the soul should perhaps also be considered. The representation of souls by birds may be intended in the curious insular Crucifixion scene from the Wurtzbourg Gospels (Masai 1947, Pl. 34).

The meaning of the two figures with staffs on the ends of the horizontal cross arms on Clonmacnoise V is problematical. It is likely that these figures are paralleled on Tihilly (see p180). The only other possible comparisons are with Duleek North and Termonfechin (Crawford, H.S. 1926b, Pl. IV; Roe 1954, Pl. XI) where two seated figures with croziers are placed on the horizontal cross arms. However, these could also be versions of the evangelist figures on Clonmacnoise V B 10 and D 10. Perhaps a more likely possibility is that they could be worshipping figures of some kind. A silver plate from Syria dating to the sixth or seventh centuries depicting the Crucifixion shows two male figures crouching at the bottom of the cross, each holding a staff with a circular device on the end (Schiller 1972, Fig. 322). Other examples of worshippers may be seen on sixth century ampullae from Monza (op cit, Figs. 324-5). There are also a couple of examples from Anglo-Saxon

England, Lindisfarne and Newent (Coatsworth 1979, 45), and the crouching figure placed actually beneath the Crucifixion on the Market Cross, Kells would seem to be a further Irish example (Roe 1966, Pl. XI, Fig. 6).

Thus the Crucifixions on Clonmacnoise V and Durrow I, while adopting the Christ type common in the Carolingian World, did not take up the expanded Carolingian iconography with it, apparently preferring to maintain a certain conservativeness by continuing to use Longinus and Stephaton as the main subsidiary elements, figures which had already been established in insular Crucifixion iconography for some time.

The Soldiers Guarding the Tomb and the Three Marys The soldiers guarding the tomb are found in the same position at the bottom of the shaft on the West face on four crosses, Durrow I A 11, Clonmacnoise V A 15, Monasterboice West and the Market Cross, Kells. The scene is also found on the right hand horizontal cross arm of Monasterboice South (Macalister 1946, Pls. XVII, IX. 35; Roe 1966, Pl. VII). On Clonmacnoise V A 15 the panel shows a combination of the soldiers guarding the tomb and the three Marys arriving to be greeted by the angel although the angel is not shown. The inclusion of the three Marys, the central figure holding a small container, is probably also intended by the three half figures placed above the soldiers on Monasterboice South; on Monasterboice West this has been reduced to two. The panel on the Market Cross, Kells is badly damaged but shows figures both above the soldiers and to the right. On Durrow I A 11, presumably due to lack of space, the representation has been reduced to the two soldiers only with a third figure, possibly the angel or one of the three women set between them. The Clonmacnoise and Durrow versions differ in one major respect from their northern counterparts; neither shows a cross set between the two soldiers⁶ although one suspects that on Clonmacnoise as there is an uncarved area between the soldiers, the cross may have been represented in paint.

The soldiers are shown nodding in sleep resting on their spears. As Porter commented (1931, 44) similar soldiers are found as early as the fourth century on Roman sarcophagi where they are shown seated either side of a triumphal chi-rho surrounded by a victory wreath (Gough 1973, Pl. 91). By the late fourth century the soldiers are shown guarding the tomb and at this stage the scene of the Marys and the angel

is also sometimes included (e.g. Beckwith 1979, Pls. 36, 37; Lasko 1971, Pl. 78). The popularity of the scene is maintained during the Carolingian period and may be seen on many ivories either as a sequel to the Crucifixion or as a part of the Passion Cycle. An example of the former dated c 820 but which closely reflects its classical origins is now to be found in the Merseyside Museum (Lasko 1972, 37, Pl. 31) while there is a version of the latter dated c 870 possibly from Northern Italy (Schiller 1972, Pl. 276). On this the soldiers are shown with splendid crested Roman helmets. This also seems to have been attempted on Durrow I A 11.

However, there is one major difference between the Irish versions and both their classical and Carolingian counterparts. This is that in Ireland the soldiers do not sit either side of the Holy Sepulchre rotunda but instead Christ is shown beneath them under a rectangular slab, presumably a sarcophagus lid, and swathed in wrappings which have the appearance of mummy bandages. There are no parallels for this and it is easy to immediately jump to the conclusion, as Porter did (1931, 45), that some Egyptian model must have been used. But, as there are no precise Egyptian comparisons either, perhaps other directions ought to be investigated. Christ does appear either swathed in a shroud or wrapped in bandages in some Eastern versions of a Passion Cycle scene showing the Bearing of the Body before it is placed in the Sepulchre. A good example of this is to be found in the Byzantine Khudlow Psalter dating to the second half of the ninth century (Schiller 1972, Pl. 567). It is possible that a model of this type could have influenced the Irish sculptors. Equally, a shrouded body is continually represented in the raising of Lazarus (Henry 1933, 156), a miracle which is early represented on sarcophagi and ivories (e.g. Beckwith 1979, Pl. 38) and is also found during the Carolingian period (e.g. Lasko 1972, Pl. 69). It is interesting to note that in the Gospels of St. Augustine (Cambridge, Corpus Christi Coll. MS. 286, f125) (Wormauld 1954, Pl. I) the Raising of Lazarus in its role as a prefiguration of the Crucifixion is included as part of the actual Passion Cycle and it is not impossible that such a connection could have led to the transference of models from one theme to the other. In addition in the unique mid eighth century Anglo-Saxon ivory depicting the Last Judgement (Beckwith 1960, 241, Pl. 3) some sarcophagi have opened to reveal swathed figures which are very similar to the Irish versions of Christ in the tomb. This is also

the closest parallel for the bird breathing into Christ's mouth shown on the Irish crosses. On the ivory birds may be seen flying towards and breathing into the mouths of bodies thus signifying their resurrection. Again, although Porter (1931, 44-5) recognized that the conception of a bird as a soul is found in Egypt, it is very much a thing of the Celtic world also and is mentioned several times in the source material.⁷ Indeed, as Anne Ross emphasises (1967, 337-341), the idea of birds representing souls does not begin with Christianity but goes right back to the Celtic pagan concept of an otherworld paradise.

Therefore, although Carolingian and Classical models form the background to the development of this scene in Ireland, the Irish sculptors do seem to have adopted the iconography to their own needs and the inclusion of the bird would seem to add a particularly Celtic aspect to the representation.

Traditio Legis Although not part of the Passion the resurrected Christ's last commission to the Apostles before His Ascension is associated with scenes from the Passion cycle at an early date. For example it is included as the central episode amongst a series of Passion scenes on a number of fourth or early fifth century Roman sarcophagi (e.g. Schiller 1972, Pls. 2-4). At a later date it is also found on one or two Carolingian ivories, for example the tenth or early eleventh century Magdeburg Antependium (Goldschmidt 1918, II, Pl. 15).

In Ireland this scene, placed at the top of the shaft on the west face of Monasterboice South as now been fairly securely identified as one of a number of scenes connected with the Passion and Resurrection (Macalister 1946, 39, Pl. VII, 23; 1932, 15-18; Hunt 1951, 44-7) although in the past there has also been a school of thought which has suggested that the panel may be a scene from the life of a saint, perhaps Columcille (Porter 1931, 39-40; Morns 1934, 207; Sexton 1946, 232). Porter identified Durrow I C 11 (1931, 44) as showing Columcille with two angels, Axal and Demal and two clerks. This seems entirely unnecessary and, like the panel on Monasterboice South, a representation of the Traditio Legis would seem more likely. However, the two panels are not closely comparable since Durrow I C 11 shows two figures, who are presumably Peter and Paul, seated rather than standing and they are offered a book between them rather than Peter receiving a key. There is also the addition of angels in the top corners of the panel. This episode

also seems to be represented on Clonmacnoise V C 13. Like the Monasterboice South version Peter and Paul are here shown standing but their droopy moustaches have become long flowing beards. The clue which identifies this scene is that a key can just be made out in Christ's right hand and a book in His left. Porter (1931, 116-7) identified this panel as showing the Miracle of the Loaves and Fishes but this may be discounted as the key and book are quite clear and there are no loaves or fishes present.

Other Scenes The positioning of Durrow I A 2 on the west face amidst other Passion scenes suggests it is also related to this series. It could be a seizing or building scene or possibly Moses, Aaron and Hur as this is placed in an identical position on Monasterboice South (Macalister 1946, Pl. X, 42).

Conclusions Scenes from the Passion Cycle with the Crucifixion at their head are undoubtedly a very important aspect of the figural iconography of both Clonmacnoise V and Durrow I and also their northerly counterparts. This upsurge in Passion iconography may surely be seen as connected with the new interest shown in Christ's Passion and death expressed in the Carolingian continent from the early ninth century onwards⁸ and which is also transferred to Anglo-Saxon England on such monuments as Rothbury (Coatsworth 1979, 77-8, 184, 200-208). In Ireland the young beardless Christ is adopted, being shown erect sometimes with a slightly inclined head and either naked or clad in a loincloth. This type must be derived from the Carolingian World but other aspects of the Crucifixion scene show much greater conservatism and a retention of earlier types. The origins of the other Passion Cycle scenes are likely to lie both in the Carolingian World and its Classical predecessor, being transmitted to Ireland through the media of ivories, manuscripts or possibly metalwork. However, close parallels are rare since the scene seems frequently to have been adapted to their Irish milieu and no more precise links may be suggested.

Finally, one should perhaps speculate as to whether crosses with Passion Cycles could have had a liturgical function as well as a didactic (see p 41). Liturgical prayers at stations round the church are known on the Continent from the end of the eighth century (op cit, 103-4) and it seems not impossible that outdoor crosses could have been used as such

stations in Ireland where church buildings tended to be small.

b) The Last Judgement

This scene, placed on the crosshead of the East face, is found on a number of Irish 'Scripture' crosses. By far the most complex version may be seen on Monasterboice South (Macalister 1946, 40-1, Pl. VIII). Christ is standing in the centre. To either side of Him are figures related to the iconography of David and Musicians and the Blessed are placed to His right, the Damned to His left. Below is Michael weighing souls on a pair of scales and above a figure set between two angels. This depiction has an extraordinarily vivacious quality which may be exemplified by the little devil prodding the Damned into Hell with a pitchfork. This scene also appears with some elements left out on Arboe, Armagh (Roe 1956, 82; 1955, 110) and Clonmacnoise V C1-4. On Durrow I C 2 it has been much reduced to show the figure of Christ only but David iconography has been introduced onto the horizontal cross arms (C 3 and 4. See forward). At Termonfechin (Roe 1954, 111) Christ is shown with the heads of two figures either side, the Blessed and the Damned (?), and another figure above His head. In addition a scene which has several elements in common with the Last Judgement, the Maiestas Dei, is found on Kells South (Roe 1966, 22, Pl. V).

As Françoise Henry (1967, 171-2) has shown the development of the Last Judgement as a sculptural theme in Irish art ties in well with its apparent importance in the Irish early Christian literature. At an early date the hymn Altus Prosator, which has been attributed to St Columcille, alludes to the Day of Judgement (Kenney 1929, 264) and there are also several examples of visions of the Otherworld. One of these, the Fis Adamnain, survives in the Lebor na h-Udri (The Book of the Dun Cow, Rawlinson MS. B.502), a manuscript dated to the late eleventh or early twelfth century and emanating from Clonmacnoise (Henry 1970, 48-9). This source describes both Heaven and Hell, the rewards of the Righteous and the torments of the Damned (Boswell 1908, 28-47). In addition there are also a number of homilies describing the Day of Doom (e.g. Stokes, W. 1879-80, 245-257; 1905, 137-47; O'Keefe 1907, 29-33) and the Last Judgement.

The Last Judgement on the crosses is dominated by the figure of Christ. He stands with His feet splayed outwards and this is a very

similar stance to that adopted in representations of Christ treading on the beasts which are frequently found in Carolingian iconography and may be exemplified by an early ninth (?) century ivory now in the Musées Royaux, Brussels (Lasko 1972, Pl. 11). On Durrow I Christ is shown standing on a bed of interlace which could possibly be a misunderstood version of the beasts. On Clonmacnoise V there also seems to be a beast beneath the little plinth on which Christ is standing. When Christ is shown treading on the beasts He is depicted holding the slender cross of the Resurrection. On Irish representations of the Last Judgement this is shown with the addition of the flowering rod, Aaron's staff, the emblem of the eternal priesthood (Hulme 1899, 154, Howlett 1974). They are held in what Françoise Henry (1933, Figs. 127 and 8; 1967, 164, Fig. 23; 1974, 190-1, Figs. 44-5) has termed 'the Osiris pose' and she has gone on to link the iconography of Osiris, the judge of the dead in Ancient Egypt, with the figure of Christ the Judge, suggesting that the Osiris figure may have been adopted for Christ by the early Christian Copts who subsequently passed it into insular iconography. While this is a possible ultimate origin perhaps it should not be emphasised too much as it seems a natural method of showing a person holding two staffs.

The practice of showing both the cross and the flowering rod is a characteristic peculiar to Hiberno-Saxon art. It first appears in the Lichfield Gospels where St. Luke is depicted with these attributes (Nordenfalk 1977, Pl. 25) and there are several related versions in the Book of Kells which may be exemplified by the figure shown at the door of the Temple on the Temptation page (f202 V). It is interesting to note that the lower half of this scene has actually been linked with the Last Judgement (Henry 1974, 189). In a recent discussion of the iconography of the Alfred Jewel D.R. Howlett (1974) has suggested the obverse shows Christ with the flowering rods, the symbol of wisdom, and he has gone on to back this up by examining the literature of the period. This concept of wisdom would fit very well with the figure of Christ at the Last Judgement.

In the Last Judgement scene Christ is shown dressed in priestly robes. These may be clearly distinguished on Clonmacnoise V. The underrobe would appear to be an amice. The upper robe with its 'U' shaped folds may probably be identified as a chasuble. Round His neck is the pallium, the symbol of an Archbishop of the Church. It is not the

pallium with long terminal bands as is represented on the Ravenna mosaics but rather a more modern form on which the terminal bands have become shorter (Cabrol and Leclercq 1907-53, XIII.1, Col. 933).

On Clonmacnoise V, although the Blessed and the Damned are depicted, they are shown merely as figural busts and have none of the vivacity or anecdotal quality of their counterparts on Monasterboice South. On Clonmacnoise V the Damned are led away by a little devil who appears to have wings and claw-like feet. These features are shared by the black devil on the Temptation page (f202V) in the Book of Kells and Françoise Henry (1974, 189-90, Fig. 42) has compared it with similar devils found in the early ninth century Stuttgart Psalter (Stuttgart Library MS Bibl. fol. 23) which has connections with the Amiens School in North France. This manuscript includes a depiction of Christ in Judgement dividing the sheep from the goats with a devil clasping a pitchfork in attendance (De Wald 1930, f6V). The general background for the development of this type is likely to be Byzantine (Henry 1967, Pls. VI, VII).⁹

As a balance to the little devil on Clonmacnoise V, the Blessed are heralded by a trumpeter. This element is characteristic of many Last Judgement scenes and is used to announce the Day of Doom (Revelation VIII,6ff). It is exactly paralleled on Monasterboice South and is also an essential feature in other Hiberno-Saxon representations in the Turin (Turin Univ. Lib. MS O.IV. 20) and St. Gall Gospels (St. Gall Cath. Lib. MS 51) (Henry 1974, Figs. 20, 21).

On Clonmacnoise V there is a bird, possibly a dove, above Christ's head. This also appears on Monasterboice South. There is a possibility that this has been included by mistake as the eagle of St. John appears below Christ in the Maiestas Dei on Kells South (Roe 1966, Pl. V). However, it seems more likely that it should represent the Holy Spirit. In a twelfth century version of the Crucifixion called the Throne of Grace God the Father is shown above the cross set between two angels with the Holy Spirit immediately below in the form of a dove (Schiller 1972, Pl. 409), the Trinity thus being represented. On Monasterboice South a figure between two angels is also shown on the top cross arm above the bird and there is a similar version on Clonmacnoise V although here the angels have lost their wings. It therefore seems likely that the Trinity is intended here also.

On Durrow I a lamb enclosed in a roundel is placed immediately above the figure of Christ. In the Maiestas Dei scene on Kells South

there is a similar lamb here held aloft by the Evangelist figure of St. Matthew. In these contexts the lamb must be the Apocalyptic Lamb, the Agnus Victor (Revelation V, 6ff, XIV, 1 ff) the lamb which symbolises Christ's eternal victory and worldwide sovereignty although it is also connected with the imagery of the Passion (Schiller 1972, 118). It is frequently found in Carolingian manuscript illuminations usually accompanied by the evangelist symbols and often by the instruments of the Passion (op cit, Pls. 397-9).

The problem with the Irish Last Judgement is that there are no close parallels for the depiction of this scene before the Romanesque period in Europe. Both the Celtic West and Anglo-Saxon England seem to have had an interest in the Last Judgement from an early period as has already been demonstrated by the source material. This is also borne out by the surviving examples in Celtic and Anglo-Saxon art. There are two definite examples of the Last Judgement in Hiberno-Saxon manuscript illumination. The first of these is the mid eighth century St. Gall Gospels (St. Gall Cath. Lib. MS 51) where the page has been divided into compartments (Henry 1974, Fig. 21). In the centre at the top is a bust of Christ holding the Resurrection Cross and a book and in the attitude of blessing. On each side is an angel blowing a trumpet. Below are the Apostles holding books. The second manuscript, the Turin Gospels (Turin Univ.Lib. MS O.IV.20), is very similar although here the angels have been relegated to the upper frame and Christ is surrounded by the Chosen (Henry 1967, Pl. 40). There is possibly a third example on the lower half of the Temptation page in the Book of Kells (f202V; Henry 1974, 189). These are very different from the scenes on the crosses which have more in common with the probably Anglo-Saxon ivory dated to the late eighth or early ninth century now in the Victoria and Albert Museum (Beckwith 1960, Pl.3; 1972, Pl. 1). This includes Christ in a mandorla, trumpeting angels, St. Michael, the dead rising from their graves and, at the bottom of the plaque, the Blessed are being received into Heaven by an angel while the Damned are being swallowed by a monster. This example demonstrates a fully worked out iconography for the Last Judgement at a relatively early date. On the Continent comparisons seem very thin. There is, in the Utrecht Psalter (Utrecht, Bibliothek der Rijksuniversitet), dated c 820, a small scene illustrating Psalm 88 which appears to show the Last Judgement with the Dead being woken from their sarcophagi by angels (Beckwith 1969, Pl. 34) and there

are also iconographical allusions to the Last Judgement in the early ninth Stuttgart Psalter (De Wald 1930, f6V, f9V). Otherwise it is not until the mid eleventh century that the Last Judgement really begins to be depicted. An early example may be seen on the west front of Abbot Adalbert's church at Bremen (Beckwith, 1969, Pl. 160). Moreover, it is not until the early twelfth century that there is anything as complex as the Monasterboice South scene. This is the ⁿtypanum above the west doorway of the Cathedral of Saint-Lazarre at Autun (op cit, Pl. 202). Thus it is very difficult to see what influences were at hand for the sculptors of the Irish Last Judgements to draw upon. There are undoubtedly Carolingian elements such as the Christ type similar to that treading on the beasts and the little devils but there are also possibly elements such as 'the Osiris pose' derived from sources further afield. More precise models remain a complete mystery and one is forced to speculate as to whether the complex iconography of the Last Judgement may to some extent have originated in the Anglo-Saxon or Celtic milieu.

c) The David Cycle

Three episodes from the David Cycle may be undoubtedly recognised on Durrow I and Clonmacnoise V; David playing the harp accompanied by musicians, David breaking the jaws of the lion, and David the Warrior. There is also a possible depiction of Goliath.

David and Musicians David playing the harp is a common iconographical element on the Irish crosses (see pp182,194). However, the addition of accompanying musicians is only found amongst the 'Scripture' crosses. This scene is found on Clonmacnoise V B 11 and D 11, Durrow I C 3 and 4 (?) and also on Monasterboice South. On both Durrow I and Monasterboice South David and Musicians are included as part of the Last Judgement iconography on the crosshead of the East face but on Clonmacnoise V it is shown on the narrow faces of the shaft. As Helen Roe noticed (1949, 55) the most complete rendering of the subject is found on Monasterboice South, where David, two musicians playing wind instruments and a fourth figure with a book, presumably a scribe, are all shown. On Durrow I C 3 David and one musician are depicted. On Durrow I C 4 the stance of the figure immediately to Christ's right suggests a dancer which may belong with the David and Musicians iconography. On Clonmacnoise V only David and one other musician are depicted.

On Clonmacnoise V B 11 David is shown playing a lyre. Porter (1931, 31) failed to recognise this and instead identified it as a huge bell which caused him to suggest that Patrick banishing the demons from the rick was being depicted. Observation renders this identification impossible as a lyre is undoubtedly shown. It looks very much like the new reconstruction (Bruce-Mitford, R.L.S. & M. 1970, 7-13, Pl. I) of the Sutton Hoo lyre except that there appears to be a horizontal wooden bar across the instrument at the level of the bridge and the bottom of the instrument is flat rather than rounded. It would also seem to fit very well with the type of lyre shown in the Durham Cassiodorus (Durham Cath. Lib. B.II.30 f81V) (Nordenfalk 1977, Pl. 27) and the Vespasian Psalter (B.M. Cotton Vespasian A i) (Wright 1967, f30V). It is also similar to the somewhat muddled version of a lyre shown in the Irish Psalter B.M. Cotton Vitellius F.XI, f2 (Henry 1960, 29-30, Pl. VI). The Bruce-Mitfords have said that this type 'must surely be the typical early Germanic stringed instrument' or *cithara teutonica* (1970, 10, Fig. 1). However, in Ireland David is not usually represented playing a lyre. The following table (Fig. 34) shows the incidence of David shown playing the lyre, the quadrangular harp and the triangular harp in Irish sculpture, metalwork and manuscripts:

Fig. 34.

	Clonmacnoise V	Durrow I	Monasterboice S.	Kells S.	Kells W.	U.Nard	Graiguenamanagh I	Kinnitty I	Castledermot N	Castledermot S	Carndonagh	Shrine of Stowe Missal	Breac Maadhog	B.M.Cot. Vit. FXI
Lyre	✓				?			?						✓
Quad. Harp		✓	✓	✓		?	✓		✓	✓	?	✓		
Triang. Harp													✓	
	} S C U L P T U R E											} W O R K		
	} M E T A L											} M S		

As can be seen David is far more often shown playing a small quadrangular harp, in fact very similar to the way in which the Sutton Hoo lyre was originally reconstructed (op cit, Pl. IV) and it is this type which is depicted on Durrow I. It is generally believed that the frame harp originated in the British Isles and it seems likely that the Irish sculptors may have been adapting their models to show David playing an instrument they knew from their own experience.

On Clonmacnoise V B 11 David is shown seated in a chair with zoomorphic features and this is paralleled on Kells West (Roe 1949, Fig. 12.44). Françoise Henry (1960, 29, Pl. VI) has suggested that it is not a chair at all but rather a sheep from David's flock which is sometimes depicted below David playing the harp. This view may be discounted if the representation of David in the B.M. Cotton Vitellius A i, f2, which provides a close parallel for the Clonmacnoise sculpture, is examined. The beast has distinctly lion-like features and its elongated neck provides the backrest while its legs form the feet of the chair. This is simply a somewhat more naturalistic version of chairs with leonine features which are relatively common in Hiberno-Saxon manuscripts. Perhaps the closest parallels are provided by the Lichfield Gospels (p.42) (Nordenfalk 1977, Pl. 24) where the Evangelist Mark is shown seated on a chair, the arms and legs and back of which have become transformed into two slender feline forms with spiralled dragonsque heads. There is another version of this in the Gospels of MacDurnan (Henry 1967, Pl. 42). Less dramatic examples are found in the Durham Cassiodorus (f81v) and on the Virgin and Child page in the Book of Kells (f7V). As Helen Roe (1949, Fig. 12.41) has shown the popularity of lion chairs in the depiction of David playing the lyre may also be tied up with the representation of Orpheus playing the lyre where he is sometimes shown actually seated on a lion.

Some confusion has arisen over the identification of David's accompanying musician on Clonmacnoise I D 11. An identical piper is shown on Christ's left on Monasterboice South (Macalister 1946, Pl. VIII). Françoise Henry (1967, 168, 173) has suggested that these may be identified as the Erythrean Sybil, a mythical figure associated with an apocryphal text describing the Day of Doom which is drawn on by St. Augustine in his City of God. This somewhat colourful view seems entirely unnecessary since David playing the harp is frequently associated with musicians and a variety of wind instruments are usually included.

Equally unlikely in the present context is Porter's suggestion (1931, 8-9) that Sidh , the magical musician mentioned in the Finn Cycle, is represented. However, the Clonmacnoise V representation does have some unusual features. Below the musicians are shown two cats with their back legs entwined and a third cat is shown leaping in the air. Cats are popular amongst Hiberno-Saxon artists (see forward) but they are not normally included amongst David iconography. Furthermore, their lively postures suggest that the music may have some sort of hypnotic effect over them and such vitality of carving certainly demonstrates the imagination of the sculptor. The origin of the cats is obscure but it could well relate to the pagan past as divine cats do play a part in Irish pagan mythology and music is also an important facet of the Celtic religion (Ross 1967, 383-4, 462). In classical mythology also Orpheus had power over animals and the image of Orpheus is closely associated with David iconography.

The type of wind instrument played seems to be ultimately of classical origin. It may be a primitive triple pipe called a launeddas (Baines 1957, 202-4). The musician on Durrow I C 3 seems to play a single pipe although the precise type is unidentifiable.

The figure on Durrow I C 4 is turned towards David and his accompanying musician. He seems to be clapping his hands, so the inclusion of a dancer seems perfectly possible. The best parallel is provided by the two little figures in the Vespasian Psalter (B.M. Cotton Vespasian A i, f30v) who clap their hands and dance a jig and in this instance David Wright (1967, 71) has suggested that they may be included in order to draw attention to the Divine inspiration of the Psalms.

In a wider sense, as David Wright (Ibid) has also shown, scenes of David composing the Psalms with musicians, scribes and dancers are ultimately drawn from Late classical aulic representations which pass into Early Christian iconography. The classical past is also evident in the figure of David playing the lyre which is derived from the classical way of showing Orpheus. Depictions of Orpheus are still quite common in the late Roman period and may be exemplified by an ivory pyxis dating to the late fourth century which was housed at Bobbio (Volbach 1961, Pl. 84). Precise parallels for the David and musician scenes on Irish sculpture are difficult to find. As has already been noted David playing the lyre on Clonmacnoise V B 11 may be compared in many aspects with the Irish psalter (B.M. Cotton Vitellius F.X1, f2) representation and the two are

generally dated contemporaneously (Henry 1960, 32). In Scotland another good parallel is provided by the three small cloaked and hooded figures on the cross slab at Ardchattan, Argyll (Allen and Anderson 1903, III, Fig. 393). The uppermost plays a quadrangular harp, the second a triple pipe and the third possibly some kind of percussion instrument. Comparisons have also been noted with other insular manuscript versions such as the *Vespasian Psalter* (B.M. Cotton Vespasian A i, f30v) and the *Durham Cassiodorus* (Durham Cath. Lib. B.II.30, f81v). Although close parallels are difficult to cite the Irish sculpture is also likely to have been influenced by Continental manuscript models. Perhaps the best parallel is provided by the ninth century *Psalter* from Angers (Angers Bibliotheque Municipale MS 18, f13v) which shows David playing a lyre and to his right a musician playing pipes (Leroquais 1940-1, Pl. VIII). Other examples are the first Bible of Charles the Bald (Paris Bibliotheque Nationale) illuminated at Tours between 843 and 851 and the *Psalterium Aureum* (St. Gall, Stiftsbibliothek) dated 890-920 (Beckwith 1969, Pls. 47, 64). There is also the possibility of the influence of ivories. One example showing David and musicians is the Book cover of the *Dagulf Psalter* dated before 795 (Lasko 1970, Pl.26).

David Breaking the Jaws of the Lion This is depicted on Durrow I C 4. It may be seen as one of a number of Irish examples of David kneeling on the back of the lion and this type is described in some detail on p149. It is somewhat more complex than the version shown on Kilree B 3 since it includes not only David, the lion and the sheep but also traces of David's attributes, a crook and a slingstone. These are also included on the Market Cross, Kells and Monasterboice West (Roe 1949, Fig. 2.14 and 15) and these provide the clearest comparisons for Durrow I C 4.

David the Warrior Porter (1931, 11) suggested that Durrow I B 8 showed Finn with his hounds but, as Helen Roe has suggested (1949, 52-4), David the Warrior is a much more likely identification. The scene is closely paralleled on Monasterboice West (Macalister 1946, Pl. XVI) and there are versions on Killarney and Carndonagh which show David standing with a shield and sword or orb (Roe 1949, Fig. 10). He also appears in a standing position in the *Durham Cassiodorus* (f172v) holding a spear and holding up a circlet inscribed 'David'. On Ardchattan, Argyll (Allen and Anderson 1903, III, Fig. 393) he holds a spear and a shield.

As can be seen the Durrow I and Monasterboice West versions are somewhat more complex than those more popularly found in insular art. David is shown in a seated position and on either side is a quadruped which appears to lay its head on David's knee. As Helen Roe (1949, 53-4, Fig. 9) has shown these beasts are likely to be derived from the lions which frequently form parts of thrones on consular diptychs. In fact consular diptychs undoubtedly provide the ultimate aulic model for later Christian representations. A good example is provided by the Constantinian diptych commemorating the Emperor Anastasius I dated to 517 (Volbach 1961, Pl. 220). He is shown seated on a chair ornamented with the heads and feet of lions. He holds aloft his staff of office and the mappa circensis. This imagery is carried on into Carolingian and Ottonian manuscript art, for example on an ivory diptych from the Alpine monastic school dated c.900 David is shown seated in a chair with zoomorphic feet holding up the mappa circensis in one hand and a spear in the other (Beckwith 1969, Pl. 27).

On Durrow I the figure has been much 'Celticized' by giving him a long plaited beard which identifies him as a lay person rather than an ecclesiastic. His broad bladed sword seems to have a central groove which suggests it is of Scandinavian type (Hencken 1950-1, 88-94).

Goliath Immediately below the musician on Durrow I C 3 is a severed head. The significance of this is not altogether clear but its identification with Goliath seems likely thus representing in cryptic form a further episode from the David Cycle. It is possible that the head shown alone may be a development of the incident depicting David raising Goliath's head on a stake found at Monasterboice West and Killeel and possibly on Donaghmore^(Co. Down) or David taking Goliath's head to King Saul which is possibly depicted in Seir Kieran (Macalister 1946, Pl. XIV.5; Roe 1949, Figs. 3.18, 7) (see pl21).

Conclusion Therefore the frequent occurrence of David iconography on these and other crosses mirrors the importance of the Psalter in Irish monastic liturgy (MacNamara 1973, 201ff). There are several Irish Psalter manuscripts surviving which belong to the tenth and eleventh centuries (Henry 1960, 23ff; Henry and Marsh-Micheli 1962, 101ff) and it is likely that there would also have been Carolingian illuminated exemplars which would have acted as models for the Irish sculptors although ivories and other minor arts may also have played a part.

d) The Evangelist Figures

Porter (1931, 28-9) mistakenly identified the seated figures on Clonmacnoise V B 10 and D 10 as representing St. Patrick. As Françoise Henry realised (1967, 173) they are undoubtedly evangelist figures, their symbols being placed above their heads. The identification of D 10 with St. Matthew, since the symbol is human, is quite clear. However, B 10 is more problematical since a symbol figure with wings is shown but the facial features bear little resemblance to any of the Evangelist beasts and so it is unknown which may be intended.

Unlike Anglo-Saxon sculpture, where Evangelist figures are relatively common (Kendrick 1938, 153), they are unusual in Ireland and there is only one example in Pictland at Elgin (Allen and Anderson 1903, III, Fig. 137). The closest Irish parallels are provided by Duleek North and Termonfechin (Roe 1954, 112) where a seated figure is depicted either side of the Crucifixion on the horizontal cross arms on the West face. Henry Crawford (1926b, 5, Pl. III, C, D) has suggested that in the case of Duleek North these are ecclesiastics, one holding an ordinary crozier, the other a tau; the second also holds a book. However, in the light of Clonmacnoise V evangelist figures seem more likely. In addition the evangelist symbols of St. Mark and St. John are shown at the ends of the horizontal cross arms on the narrow faces (op. cit, Fig. 1). Helen Roe has suggested (1966, 25, Pl. VI) that the two figures at the top of the north face of Kells South may represent Saints Peter and Paul enthroned. However, since they have beasts over their heads and they rest books on their laps, evangelist figures would seem more likely. On this cross further evangelist symbols are represented in connection with the Maiestas Dei (op. cit, Pl. IV). There is a further possible example on the South face of the fragmentary cross from Armagh (Roe 1955, 109).

As might be expected the Clonmacnoise V evangelists seem to have their closest parallels with manuscript illuminations. It is only strange that they are not more frequently represented in Irish sculpture considering their universal use for illustrating Gospel Books. The best comparisons may be made with the Book of MacDurnan and some of the other smaller pocket gospels such as that from the Stowe collection (Dublin R.I.A.MS. D.II.3) (McGurk 1956, 249ff; Henry 1957, 146-166). A colophon records that the Book of MacDurnan was in existence in the time of Maelbrigte MacTornain who was abbot of Armagh and head of the Columban paruchia from c 888

until he died in 927 (Henry 1967, 102-3). The decoration of the gospels includes four evangelist portrait pages. The St. Luke figure may be closely compared with the figures on Clonmacnoise V (op cit, Pl. L). Like the figure on B 10 he holds a crozier in his left hand, a gospel book in his right. Like St. Matthew on D 10 he has long curling tendrils of hair (?) or drapery (?) round his shoulders and his outer robe terminates in points. His feet point forwards and are clad in slippers. The St. Matthew portrait in the Book of MacDurnan also has these features, the spiral ornament round the shoulders here suggesting a halo (op cit, Pl. 44). The St. Mark Evangelist portrait has his symbol placed immediately above his head (Ibid, Pl. 42). The surviving Evangelist portrait, St. John, from the Stowe gospel book, which is dated possibly to the late eighth century, shows the eagle symbol placed behind and above the Evangelist figure in an identical way to that used on Clonmacnoise V (Henry 1957, 154, Pl. XXVIIIb). The spiralled detail on the eagle's wings and the vertical lines of the feathers may be compared with B 10.

Two details of Clonmacnoise V D 10 are unusual. Firstly, St. Matthew holds a tau crozier for which there are no manuscript parallels though it is possible that this has been metamorphised by the sculptor from one of the vertical inkstands which are very frequently depicted, for example on the Book of MacDurnan St. Matthew page (Henry 1967, Pl. 36). Secondly, he has a book satchel placed round his neck. This may be compared both with the evangelist figures in the Book of Deer (Cambridge Univ. Lib. MS.I i.6.32) and also with representations on Pictish cross slabs at Bressay, Shetland, and at Elgin (Hughes 1980, 28, Fig. 3, Pl. II; Allen and Anderson 1903, III, Fig. 4A, Fig. 137).

Thus the Clonmacnoise V evangelist figures emanate from a distinctly insular manuscript tradition and these figure types reach right back to those employed in the Gospels of St. Augustine (Cambridge Corpus Christi MS 286) and the Codex Aureus (Stockholm, Royal Lib. Codex Aureus MS. A.135) (Wormald 1954, 7-9, Pls. II, XV). It is likely that Carolingian models may also have attributed their influence since seated Evangelist figures holding books with their symbols placed above their heads are frequently found. They may be exemplified in the manuscript medium by the early ninth century Gospel Book from the Palace School, Aachen (Beckwith 1969, Pl. 31) and the B.M.Harl.2788 of the same date (Boinet 1913, Pl. VIII) and there is a fine example of an ivory depicting the four evangelists and their symbols belonging to the ninth century Ada group (Goldschmidt 1918, I, No. 19).

e) Old Testament Iconography

The Fall; The Murder of Abel These two episodes are linked on a number of monuments, the South and Market Crosses, Kells, Donaghmore, Monasterboice South, Bray, Drumcliff (Roe 1966, Pls. II, VII; 1956, 86-7; Macalister 1946, Pl. V; Conway 1975, 54; Henry 1970, Pl. 53) and possibly Ullard (see p 193) as well as on Durrow I B 9 and 10 where the murder of Abel is found on the panel above the Fall. The Fall iconography on Monasterboice South, Bray and Durrow I B 10 is Type I (see p181), where Eve is shown handing Adam the apple, and, apart from minor alterations such as the interlaced branches of the Tree on Durrow (also found on Drumcliff) and the fact that Adam has not yet grasped the apple on Monasterboice South, the three are closely comparable.

The Murder of Abel may be seen as a prefiguration of Christ's Crucifixion (Michel, P.H. 1958, 195). The version on Durrow I B 9 differs somewhat from the other example since Cain is not shown bearded. He looks as if he is wearing a helmet of Roman type. However, like the versions on Kells South and Monasterboice South, Cain is shown grasping Abel's arm with one hand and hitting him on the head with a jawbone although on Durrow this has become rather spoon-shaped. On Durrow Abel is shown seated but if Kells South and Monasterboice South are examined it may be seen that perhaps what the sculptor intended to show was Abel crumpling up under the force of the blow.

The interesting feature of this scene is Cain's weapon, the jawbone. As Meyer Shapiro has shown (1942, 205-212) this is a particularly insular feature which is variously identified in Anglo-Saxon and Irish literature from the ninth century onwards as the jawbone of an ass or a camel (Seymour 1922, 129). There seems to have been quite an interest in Ireland in early episodes from Genesis and Apocryphal stories connected with them and it seems likely that this detail was drawn from some Apocryphal source (op cit, 121).

It is difficult to be sure from whence the various versions of the Fall and the iconography of the Murder of Abel may have been drawn. However, since more than one episode from Genesis is depicted, one may perhaps suggest that Irish sculptors may have been drawing on illustrated manuscripts of Genesis, the Pentateuch or perhaps manuscripts of the entire Bible which were becoming popular on the Carolingian Continent in the late eighth and early ninth centuries. Unfortunately no insular

illustrations of Genesis survive and the literature only hints at the particularly Celtic flavour of details of the story. However, the practice of illustrating Genesis is found amongst surviving Late Antique manuscripts and the seventh century Ashburnham Pentateuch points to the existence of complex Genesis iconography which may be illustrated by the story of Cain and Abel (f6 R) where a number of episodes are included (Weitzmann 1977, 22, Pl. 44). The popularity of Genesis illustrations continues into the Carolingian period and may be exemplified by the Bamberg Bible (Bamberg, Staatliche Bibliothek) illuminated in Tours in the second quarter of the ninth century (see p118) and the Grandval Bible (B.M. Add. MS.10.546), also from Tours, dated c 840 (Beckwith 1969, Fig. 50; Mutherick and Gaehde 1977, 25, Pl. 20).

The ultimate origins of the Murder of Abel however, date back to the art of the catacombs and it is also found on some sarcophagi. Unlike Ireland it is rarely found on the Continent during the Carolingian period or before the end of the eleventh century (Michel, P.H., 1958, 194-7).

The Sacrifice of Isaac This scene is depicted on Durrow I C 9 at the top of the shaft immediately below the Last Judgement.

The symbolism of the Sacrifice of Isaac in Early Christian theology is complex. Firstly it may be seen as part of the Help of God iconography connected with the prayer for the dying, the commendatio animae (see p 121). However, it also has important associations with the Passion. These were first suggested by St. Paul in his Epistle to the Hebrews XI, 17 and 19 and this view was amplified by such early Church Fathers as Ambrose and Isidore of Seville (Bailey 1977; 1980, 173-4). Alison Moore-Smith succinctly summarised these associations by saying:

'Like Christ Isaac was a beloved only son offered as a consummate yet willing sacrifice by his father. The place of sacrifice in both instances was upon a hill. The thorns of the bush in which the ram was caught represented the thorns of Christ. No smallest detail that might contribute to the parallel escaped the eager interpreter. The ram in the bush was Christ on the Cross, Isaac was Christ in the Holy Eucharist'

(1922, 159)

A model emphasizing this parallelism in the Anglo-Saxon context is mentioned by Bede when he describes the cycle of paintings bought by

brought by Benedict Bishop to Jarrow (Plummer 1896, 373) and on a badly damaged ivory which has been considered Anglo-Saxon (Beckwith 1972, Pl. 19) the Sacrifice of Isaac is placed directly above the Crucifixion (Goldschmidt 1918, I, No. 184).

Stemming from this comes the idea that the Sacrifice of Isaac signals the Redemption and, in the context of the Old Testament^a, may be seen 'as a climax to events which the Fall has set in train' (Bailey 1980, 173). Richard Bailey 1977, 66-7; 1980, 172-4) noticed that on Anglo-Saxon sculptures at Breedon, Leicestershire, and Newent, Gloucestershire, and the later shaft from Dacre, Cumberland, the Fall and the Sacrifice of Isaac are found together and he has gone on to suggest this may be so because the Sacrifice of Isaac 'is prophetic of the Redemption which will undo the work of Adam and Eve' (1980, 74). This may also be significant in the Irish context as on the South and Market Crosses, Kells, Durrow I and particularly Donaghmore (Roe 1966, Pls. IV, VII; 1956, 86-87) the Sacrifice of Isaac is seen in close association with both the Fall and the Murder of Abel and it is possible that, since the Murder of Abel also prefigures Christ's Crucifixion, a further nuance of the Fall and Redemption theme may be indicated.

The type illustrated on Durrow I C 9 is the most common found in Ireland, the closest parallels being on Monasterboice West, Arboe and Armagh (Macalister 1946, Pl. XIV; Roe 1956, 82; 1955, 109) although on these Abraham is bearded, with other examples on the South and Market Crosses, Kells, Seir Kieran D 3 (see p121) and some of the monuments of the Barrow Valley group (see p193). The type is ultimately derived from the Hellenistic type first described by Alison Moore-Smith (1922, 161-3, 171-2) which originated in the art of the catacombs and is also found amongst other objects on the sarcophagi of Rome, Gaul and Spain (Gough 1973, Pls. 41, 87, 90). The detail on Durrow I showing Abraham beardless is a particular feature amongst the Gaulish sarcophagi.

However, there are some distinctly insular features. Firstly, Meyer Schapiro (1943, 134-147; 1967, 17-19) has discussed at some length the detail showing the ram being held by an angel rather than simply being caught in a thorn bush. The earliest recorded instance of this is found amongst the Irish sculpture and it is not until the Romanesque period that it appears on the Continent. There are also late Islamic parallels but Schapiro believed that the most likely derivation was from Jewish iconography. He also pointed out (1943, 140-1) that, at the beginning

of the Carolingian period, the Englishman Alcuin in his Interrogatione et Responsiones in Genesiu questioned how the ram appeared at the Sacrifice of Isaac and, drawing on the influence of Jewish sources he replied:

'Aries iste non putativus, sed verus esse credendus est. Ideo magis a doctoribus aestimatur, aliunde eum angelum atulisse, quam ibi de terra, post sex dierum opera, Dominum procreasse.'
(Migne 1844-64, Vol. C, Col. 545)

'That ram is not to be considered imaginary, but a true ram. It is therefore supposed by the learned that an angel brought him from some other place rather than that God created him then and there from the earth, after the works of the six days.'

Therefore the literary background to this feature is at once apparent although any contemporary pictorial parallels there may have been outside Ireland have not survived.

Secondly, as Richard Balley noticed (1977, 64), the altar on insular versions is placed between Abraham and Isaac. This is very rare on the Continent.

Jacob and the Angel One other Old Testament scene is found on both Clonmacnoise V B 14 and Durrow I D 10, Jacob wrestling with the Angel. This subject has already been discussed in connection with similar representations on Kilree D 5 and Killamery D 3 (see pl49). On Durrow I it is placed in a similar position to the version on the Market Cross, Kells (Roe 1966, Pl. XII).

f) Manus Dei

The Hand of God is depicted on a small panel under the horizontal cross arm on Clonmacnoise V B 6. It is precisely paralleled on Monasterboice South (Macalister 1946, Pl.X.39). However, it is unusual for the Manus Dei to be shown in isolation. It does not seem to have anything to do with the serpents and human heads on B 9 (see p244) and it seems most likely that it was taken from a model which showed a much more complete scene. The Manus Dei is used to denote an action of God both in the words of the Bible, in the Old and New Testaments, and in iconography. (Cadbroil and Leclercq 1907-52, Vol. 10.1, 1206-10). The most common scenes in which it is shown are the Sacrifice of Isaac, Moses receiving the laws, the Baptism of Christ, the Crucifixion and the Ascension. The hand is

frequently shown issuing from a cloud. The nimbus effect behind the hand on Clonmacnoise V B 6 is probably a stylized cloud. The ultimate origins of the Manus Dei are pagan and centre on Syria. It first appears in Christian iconography in the first quarter of the fourth century.

g) Other Figural Iconography

Clonmacnoise V C 14 and 15 These two panels are probably linked. The lower shows an ecclesiastic and a figure clad in the garments of a layman holding a staff between them which they appear to be planting in the ground. This has generally been thought to represent a 'foundation' scene. It is suggested in Petrie's Christian Inscriptions of Ancient Ireland, edited after his death by Margaret Stokes (1872, I, 42-4) that this represents Colman abbot of Clonmacnoise (Obit 924 AFM) and King Flann mac Máel Sechnaill (Obit 914 AFM; 915 (recte 916) C.S.) who are known to have erected a stone church at Clonmacnoise at the beginning of the tenth century.¹¹ This identification is attractive but problematical since it seems to have been used by Petrie to back up his somewhat fanciful interpretations of the fragmentary inscriptions on the monument (see forward). A different suggestion was put forward by Porter (1931, 26) who believed the panel represented the founder of Clonmacnoise, St. Ciarán, with his protector King Dermot and this is supported by a passage from the Book of Lismore.¹² However, there seems little likelihood that the exact identification of the figures will ever be resolved.

This scene is not peculiar to Clonmacnoise. It is also found on the base of the late cross at Dysert O Dea, Co Clare (De Paor, L. 1955-6, 60) and the cross of Clones, Co Monaghan (Harbison 1979, 187).¹³ What is interesting to note about it is that it seems to be one of only 2 examples we have in Ireland of a religious ceremony unconnected with Biblical iconography, the second being the Ahenny I funeral procession (see p118). Different church ceremonies are found elsewhere, for example the scenes representing the order of the Mass on the Sacramentary of Drogo dated c 845 (Lasko 1972, 43-4; Goldschmidt 1918, I, Pl. XXXb). However, there are no parallels for the Irish foundation scenes in this period although Porter (1931, 27, Fig. 27) has suggested that a Romanesque capital from Quedlinburg in Germany and an early Coptic lamp from Alexandria may represent a similar ceremony. The inclusion of this scene on Irish crosses suggests an event is being commemorated, perhaps the foundation of

the monastery on an anniversary of it, or the erection of a particular building, but above all it demonstrates a pact between the Church and the secular state. After all this was essential for a monastery like Clonmacnoise to achieve its importance and maintain its prosperity (see pp 45,201). The panel above, C 14, probably represents secular onlookers. An audience is also depicted on Clones and Dysert O Dea. Porter (1931, 26) thought that it might show Dermot and Moel-Mor agreeing to found the monastery but this is pure speculation.

Some details of both panels are interesting, particularly for the light they shed on the dress of the period (de Paor, M. & L. 1960, 101-5). The right hand figure is shown in a short tunic or léine decorated with an embroidered border (corrthar), probably of a similar type to those found at Lagore (Hencken 1950-1, 214-7, Pl. XIX.3). A short sword is fastened to his belt (criss). The clean-shaven ecclesiastic wears an underrobe or amice with an embroidered border and an overrobe or chasuble. Françoise Henry has suggested (1967, 191) that the figure carries his book satchel on his back and there is perhaps some evidence for a hood. The laces of his shoes look as if they tie across the top of his foot and the shoes seem to have a projecting tongue of leather rather like the campagni worn by David on f30 V of the Vespasian Psalter (B.M. Cot. Vesp. A.1) (Wright 1967, 71). The two figures on Clonmacnoise V C 14 are dressed in long robes and a cloak (brat) fastened by round brooches at the shoulders. They may be compared, although they lack some vitality, with the figures probably depicting saints or apostles on the lower register of the Breac Maodhóg which is believed by Joseph Raftery to date to the eleventh century but could well be later (1941, 152-3; Mahr 1932, Pls. 60-62.1a; Henry 1971, 116-9, Pls. 34-7).

Clonmacnoise V D 12 This panel depicting a seated figure with a long staff attempting to poke the eye out of a second figure who writhes on the ground in front of him is very problematical. Porter (1931, 30) tentatively suggested Patrick vanquishing the Devil but, as has been stated above, there is absolutely no reason to show Patrician stories in a monastery unconnected with that saint. Françoise Henry (1967, 173) has a more tenable theory to put forward. She has suggested that the scene is connected with the Last Judgement on the crosshead of the East face and depicts St Michael fighting with a devil. This is perfectly

possible since, on Monasterboice South (Macalister 1946, Pl. VIII), St Michael may be seen with his long staff prodding a little devil who is attempting to tip the scales of Judgement in the wrong direction. However, if the identification is correct there are no scales, Michael is sitting in a little curved seat and the devil has lost any features which would have made it recognisable.

Models for this scene are equally difficult to suggest but one possibility may be late Classical ivories. The staff held by the seated figure has a bird on the top and in this it may be compared with the short staff held by the Emperor in diptyches such as that depicting Anastasius I dated to 517 now in the Paris, Cabinet de Médailles (Volbach 1961, Pl. 220) except that here the eagle is surmounted by a portrait in a victory wreath. A long staff with a bird on top is also held by Otto III in the Gospel Book of Otto III dated 997-1000 on the page depicting him enthroned and receiving the homage of the four different parts of the Empire (Beckwith 1969, Pl. 85). One wonders if the position of the second figure on Clonmacnoise V might be derived from something like an emperor trampling on barbarians although usually he is shown on horseback. There is also a ninth century ivory from the group showing two scenes of a triumphant warrior standing on his fallen foe and threatening his face with a spear (Goldschmidt 1918, I, No. 10).

Durrow I D 8 Françoise Henry (1967, 179) has suggested that the scene depicted on this panel shows the Flight into Egypt although Porter (1931, Fig. 55) has also tentatively put forward the Expulsion from Paradise. The latter seems unlikely since a baby is shown but a firm acceptance of the former is also problematical. There is one undoubted example of the Flight into Egypt on the cross at Moone (Henry 1965, Pl. 72) but in this instance Mary and the Child are shown mounted on a horse or donkey which is being led by Joseph. On Durrow I D 8 there is no beast present and the scene simply shows two figures with a child clinging to the back of the first. The first figure is likely to be female as the hair is braided. There is one parallel for carrying a child in this fashion on Ahenny I B 9 (see p 118) but the context is entirely different since a funeral procession is being depicted. As Françoise Henry noted (1967, 179) there is one possible parallel which supports the idea that the Flight into Egypt is intended. This is to be found on a ninth or tenth century ivory reliquary casket of the Metz School now in the Louvre

(Goldschmidt 1918, I, Pl. 95) which shows a series of scenes from the early life of Christ. In the Flight into Egypt Mary and Joseph are led by the angel and followed by a fourth figure. Mary carries the Baby in her arms. Thus the two are not very close but perhaps that on Durrow I is a very much abbreviated and Celticized version which depicts the Baby being carried on the back as that was the natural Irish way of doing things. The scene, if identified correctly, is shown in total isolation as there are no other episodes from the early life of Christ on this cross.

Durrow I D 2 The identification of this crouched or seated figure on the upper cross arm is difficult. It is placed in the same position as the Evangelist figures on Kells South (Roe 1966, Pl. VI) but there is nothing to show that the Durrow figure is similar. The only possible diagnostic feature is the outstretched palms. This leads one to suggest that it might be Christ showing His wounds but it is nothing like the panel depicting the Dispelling of the Doubt of Thomas on Monasterboice South (Macalister 1946, Pl. VII.23) so this must remain extremely tentative.

Clonmacnoise V A 17 This panel is very badly weathered but two identifications seem possible. The first of these, which Porter suggested (1931, 13), is the Adoration of the Magi. The central figure may be Mary seated face on with the Christchild on her lap and the figures on the right hold rectangular objects which could be the gifts of the wise men. The difficulty arises as to who the other three figures approaching might be. They may have been added to balance the scene and could possibly include Joseph or be shepherds or, as in the mosaic at Saint Apollinare Nuovo in Ravenna, angels (Volbach 1961, Pl. 152). The Adoration of the Magi may definitely be recognised on Monasterboice South (Macalister 1946, Pl. V.20) where Mary is shown in profile being approached by Joseph and the Magi and a similar version is to be found on the Market Cross, Kells (Roe 1966, Pl. XI). At Clones Mary and the three Magi are all shown face on (Henry 1967, Fig. 30) and further variations are to be found on Armagh, Arboe, Donaghmore and Camus Macosquin (Roe 1955, 109; 1956, 83, 86).

A second possibility is Christ's mission to the Apostles. A panel

probably depicting this is to be found on Ahenny I A 7 (see p117). Here Christ is shown standing and the Apostles carrying croziers but otherwise the figures on the two monuments are not dissimilar. The rectangular objects carried by the figures on the right on Clonmacnoise V could be books.

Clonmacnoise V B 14 and 15; C 17 and 18 These panels depict scenes of armed men, stags pursued by hounds, horsemen and chariots. Scenes of this type have already been discussed in some detail in connection with the Ossory crosses (see p123) and these may be seen as continuations of the same themes. However, two of the panels have close parallels with scenes on monuments in the Kells group. The procession of horsemen on C 17 may be compared with a much livelier group on the base of the East face on the Market Cross (Roe 1966, Pl. VII) and the two chariots on C 18 are similar to scenes of chariots with accompanying horsemen on the base of Kells South and Monasterboice South (op cit, Pl. IV; Macalister 1946, Pl. III, 7 & 8). The hunting scene on B 15 seems to have most in common with a panel on the base on Castledermot South (Henry 1967, Pl. 65) while the men armed with spears on B 14 may be compared with those on Seir Kieran A 3 (see p125).

Conclusions Therefore a very wide variety of figural iconography is depicted on Clonmacnoise V and Durrow I. The overwhelming majority of the scenes are Scriptural and the sculptors have paid particular attention to the illustration of the Passion cycle, the Last Judgement, episodes from the David Cycle and stories from Genesis. Figural scenes unconnected with the Bible are also included and in particular an interesting panel on Clonmacnoise V C 15 which may commemorate the foundation or building of part of the monastery. Other scenes such as horsemen and chariots are also included.

The iconography of Clonmacnoise V and Durrow I is very closely related to the Northern 'Scripture' crosses and particularly to Monasterboice South which depicts very many of the same scenes, although frequently more fully and in a more lively style. On a broader front close parallels are remarkably difficult to find. Much of the iconography, the Passion cycle for example, may be fitted in with Carolingian developments during the first half of the ninth century and the influence of ivory and manuscript models from the Continent may undoubtedly be felt

although it is difficult to pinpoint many close comparisons or any particular period or geographical location from whence these influences may have emanated. The influence of the Late Antique, particularly in the form of ivories and sarcophagi, also seems to have been present although this may have been passed on via Carolingian models. However, much of the detail depicted on these crosses has a particularly insular flavour which is frequently mirrored in the literature or may be compared with Hiberno-Saxon or Anglo-Saxon manuscripts or sculpture but which does not seem to be paralleled on the Continent at this date. This is particularly true of the Last Judgement where comparisons outside the insular context seem impossible to demonstrate before the Romanesque period.

4) Beasts

a) Fantastic Animals

Two base panels on Clonmacnoise V D 14 and 15, are decorated with processions of fantastic beasts. The panels are severely weathered and therefore details are difficult to make out but a variety of fantastic quadrupeds may be identified, some with wings or birds' heads.

These beasts fall into the category already discussed in connection with the shafts at Tybroughney and Roscrea (see p159) and they may be seen as a continuation of a theme popular on sculpture in both Ireland and Pictland. In Ireland particular parallels may be noted with sculpture on the bases of the Market Cross, Kells and Monasterboice South (Roe 1966, Pl. XII; Macalister 1946, Pl. III). Macalister suggested (op cit, 34) that the Monasterboice creatures might be interpreted as representing signs from the Zodiac. In their badly weathered state this seems impossible to be sure of but perhaps the closest parallels outside Ireland should be drawn with a Carolingian ivory showing the Garden of Eden now in the Louvre (Goldschmidt 1918, I, No. 158; Lasko 1972, 47-8, Pl. 43). This ivory, which has close stylistic links with an ivory flabellum handle dated c 850 and possibly attributable to Tours, shows Adam and Eve with Paradise laid out before them. Beasts, both fantastic and naturalistic, are set out in six registers interspersed with acanthus and other plant ornament. The beasts include centaurs, lions, griffins and other strange animals with tusks and horns which have much in common with those on Clonmacnoise V.

b) Cats

Cats are depicted twice on Clonmacnoise V. Firstly, a cat eating a fish is tucked away on a small panel under the horizontal cross arm, D 6. Cats are also included, two adored and interlaced, a third leaping in the air, on D 11, a panel which has been identified with one of David's musicians (see above).

The Hiberno-Saxon artist seems to have had a particular affection for cats.¹⁴ This may be most clearly seen in the Book of Kells where the variety of feline creatures is quite extraordinary, ranging from lions with curley manes and sharp teeth down to the small domestic cat which is shown scratching its back, chasing mice or simply stalking between the lines of the text (Henry 1974, 206-7, Pls. 106, 118). The obvious delight which the illuminations of the Book of Kells found in the cat is continued on Clonmacnoise V and is also found on the butt and under one of the horizontal cross arms of Monasterboice South where pairs of cats are displayed on three faces (Macalister 1946, Pls IV, X.37). More cats are to be found on the crozier of the 'Abbots of Clonmacnoise' (Henry 1970, Pl. 33).

Quite why the cat was so popular is more difficult to determine. It seems very likely that it stretches back into the pagan past where cats and cat headed men play a small but significant part in the myths of early Ireland and Wales (Ross 1967, 135-6, 383-4). Whether they have any Christian significance is more doubtful although those on the chi-rho page, f 34R, of the Book of Kells (Henry 1974, Pl. 106) are shown with a round cross marked disc, presumably representing the Host. It is more likely that, with other naturalistic animals in this book, they represent the animals known to the monks who wrote it.

5) The Ornament

There is little abstract ornament on Clonmacnoise V or Durrow I and what there is, with the exception of the interlace on Durrow I C 10, is confined to the less important parts of the monuments where it is frequently used as a filler. There are one or two shaft panels on the narrow faces, Durrow I D 9 and Clonmacnoise V B 12, but otherwise it has been limited to the wheel arcs, butt and upper or horizontal cross arms.

Three styles of carving are apparent. The first, in high rounded relief, is typified by the bossed spiral panels which are either combined with writhing snakes, also in high relief, as on Durrow I C 1,

or with more delicate incised detail as on Durrow I C 9. Such use of high relief may be compared with the figural sculpture. By contrast the second style is in low flat relief which may be exemplified by the interlace on Durrow I C 10. The third style is in such low relief that the ornament has an almost incised appearance, for example Clonmacnoise V B 5.

a) Spiral Ornament

This type of ornament is the most prolific on these two crosses. It is employed in a number of different ways. Firstly, bossed spirals linked by incised 'S' or 'C' scrolls are used to decorate three rectangular panels Durrow I D 9 and Clonmacnoise V A 1 and B 1. Durrow I D 9, with its slightly raised slashed spiral expansions, is similar to Kinnitty I C 9 (see pl78) although here the pattern is set three elements abreast. The two panels on Clonmacnoise V are conceived on a much smaller scale and in both instances a diagonal pattern is employed showing a central spiral linked to four other ones by 'C' scrolls, they being linked to each other by 'S' scrolls. Similar patterns in an identical position are to be found on Monasterboice West (Macalister 1946, North face No. 11, XIII, South face No. 11). Some features of the pattern may also be compared with Clonmacnoise V C 2. On Clonmacnoise V B 1 there is the unusual addition of a small spiral in the bottom right hand corner. This addition is difficult to account for since it renders the pattern asymmetrical but it may have been employed by a sculptor who was unsure how to terminate the pattern without the addition of a further register. The addition of smaller spirals in a similar way may be noted on Monasterboice South (Macalister 1946, Pl. VI.28).

The second type is bossed spirals combined with writhing snakes. These are discussed in connection with the zoomorphic ornament (see forward).

Spiral ornament is also used to decorate some of the wheelarcs. On Durrow I A 5 and 6 and in an identical position on Clonmacnoise V A 5 and 6 the wheel arcs are ornamented by spirals raised into low bosses and linked by 'S' or 'C' scrolls. Similar, though more complex designs, may also be seen on the East face of Monasterboice South (op cit, Pl. VIII). There are also long thin bands of interlocking spirals on Durrow I B 5, B 7, D 5 and D 7 and Clonmacnoise V B 7 and B 8, but these are carved in very low relief.

The ways in which the spiral ornament is used may be closely compared with Monasterboice South and West. In a broader context Françoise Henry (1967, 31) has commented that spiral ornament becomes scarce on metalwork during the course of the ninth and tenth centuries and this is also true of manuscripts. Therefore it is interesting to note that it continues to be used to a certain extent in the sculptural medium.

b) Interlace

Interlace is little used. On Clonmacnoise V it is confined to a crude mesh of strands used to fill up the gable ends of the capstone and narrow bands of ornament on D 7 and 8. The pattern, Half A turned, is competently carried out and is one which is commonly found decorating narrow bands on metalwork. Its use may be exemplified by the large brooch from the Ardagh hoard and ornament on the knops of St Dymphna's crozier (Mahr 1932, Pl. 55.1; MacDermott 1955, Pl. XXXVI).

However, on Durrow I interlace is employed more extensively and its use for a prominent shaft panel, C 10, is interesting considering the overall importance of the figural ornament. This panel is important as close links may be demonstrated between it and the crosses Kinnitty I and nearby Tihilly (see p172). These two monuments make use of a 2 cm unit measure constructed on a square grid and the strand width usually employed on Kinnitty I is 1.5 cm. The same unit measure and strand width are used on Durrow I C 10 and the same pattern, Encircled and Turned D, is found on a similar shaft panel, Kinnitty I A 2. Both patterns also show the addition of simple E elements between the main pattern units although on Durrow I this seems to have been achieved by the bifurcation of the strands running along the top and bottom of the panel. It is possible that both also contain the knot apparent in the centre of the pattern on Durrow I. Unfortunately on Kinnitty I the façade is lost at this point. The style of carving is also comparable, since little attempt has been made to carve away much of the background, the result being that the strands have a rather flat appearance.

There is a second interlace panel on Durrow I D 4. The panel has been clearly divided into four by diagonal lines and two knots have been placed in each triangle but the pattern does not seem to fit into the Adcock system of categorization. The best comparisons may be made with some of the simple interlace motives, many of which make use of pointed

loops, found on the oldest parts of the Kells crozier (MacDermott 1955, Fig. 12.25 and 26). Both the pellet at the centre of D 4 and the bifurcation of the strands on C 10 are features which are sometimes considered as late and particularly characteristic of Norse designs (Stevenson 1956, 93).

In addition there are the fragmentary remains of interlace patterns on the mouldings at the ends of the horizontal cross arms on the broad faces of Durrow I. This is directly paralleled on Monasterboice West (Henry 1967, Pl. III) and may perhaps be compared with the practice of decorating the mouldings with ornament found in Pictland on some of the later Class II and Class III monuments, for example Cossins and also St John's Cross, Iona (Allen and Anderson 1903, III, Fig. 230A).

c) Zoomorphic Motives

Serpents Two different serpent motives are found on Clonmacnoise V and Durrow I. The first of these shows a bossed spiral design with snakes emanating from the bosses. They are seen from above and have the appearance of grasping each other's necks in their jaws. They are found on Durrow I C 1 and on the discs on the wheel on Clonmacnoise V C 9 - 11 with a slight variation on C 12 since the 'serpents' here have front limbs. Durrow I C 1 in particular is closely paralleled on Monasterboice South where the motif is found in a similar position on the crosshead and there are also serpent and boss patterns on the wheel arcs of Monasterboice West (Macalister 1946, Pls. IX, XVIII). The background and earlier development of this motif has already been discussed in some detail in connection with the representation of serpents and dragons on Killamery and amongst the Clonmacnoise monuments (see pp138, 62). Its use on the 'Scripture' crosses demonstrates the continuing popularity of this motif although it does not seem to be paralleled on later metalwork or manuscripts. Since the serpents are seen from above they may be compared with those found in the Book of Kells (f 33R) and in 'Boss Style' metalwork such as the Rcmfoh jellen Mount, the St Germain plaque and the small bronze roundel in the Universitets Oldsaksamling, Oslo (Petersen 1940, Pl. 67; Mahr 1932, Pls. 24, 25, 31.10). Further comparisons may be made with Pictish 'Boss Style' sculpture especially Nigg (Allen and Anderson 1903, III, Fig. 72) and with St. John's and St. Martin's crosses, Iona (op cit, Figs. 397B, 399).

The second motif, a two strand twist of serpentine bodies, enclosing

human face masks, is found underneath the wheel arcs on the narrow faces of both Clonmacnoise V B 9 and D 9 and Durrow I B 6 and D 6 and it is precisely paralleled on Monasterboice South (Macalister 1946, Pl. X.62, .59). This is most likely to be an adaptation of the motif already discussed above since this sometimes incorporates face masks shown in the grip of the jaws of serpentine dragons as on the St Germain plaques (Mahr 1932, Pls. 25, 26). Further comparisons may be made with sculptural panels on Termonfechin where human face masks have been incorporated into a spiral design (Roe 1954, 112, Pl. XI), and Kells West, where a bossed spiral pattern with writhing serpents also includes two human face masks (Roe 1966, 53, Pl. XVIII). Face masks retaining a certain number of insular facial characteristics are also a feature of the Irish Romanesque and may be exemplified by those decorating the church doorways at Dysert O Dea and Clonfert (Henry 1970, Pls. 74, 75, 83).

In addition there are traces of zoomorphic interlace on the wheelarcs on Durrow I A 7 and A 8 and C 7 and on Clonmacnoise V C 5 and 6 and possibly A 7 and 8. These panels are for the most part badly weathered and since they were carved in low relief very little detail survives. They would seem to fit into the same category as those in similar positions on Monasterboice South (Macalister 1946, Fig. 9. 48-51) which show processions of beasts with spiralled bodies very much in the same tradition as those discussed in connection with the Clonmacnoise monuments, Kinnitty I and Tihilly (see pp65, 174). On Durrow I C 7 two registers of pairs of confronted quadrupeds with their limbs interlaced may be discerned. They would seem to emanate from a similar background.

d) Anthropomorphic Motives

There is a single example of an anthropomorphic motif on Clonmacnoise V B 12. It is somewhat crudely executed since the actual lines of the limbs and bodies seem to have been absorbed into a lifeless interlace mesh; the only anthropomorphic elements which remain are the human heads with long curling hair locks which form the corner terminals of the two registers. The panel is exactly paralleled on Monasterboice South (op cit, Pl. VI.27). Here the actual carving is in somewhat better shape but the essential details of the limbs have for the most part been lost. Further comparisons may also be suggested with a rather muddled anthropomorphic pattern on Kells South, which in turn has possible links with Tihilly C 7 (see p176), and with a very degenerate pattern on Monasterboice

West (Macalister 1946, Pl. XIX.3) which, although it has lost all its anthropomorphic elements, still retains the basic shape of Clonmacnoise V B 12. Patterns of this type may be seen as a much less accomplished continuation of anthropomorphic patterns already discussed in connection with the Clonmacnoise group (see p 68). There do not seem to be any parallels amongst the later manuscripts and metalwork.

e) Inhabited vine-scroll

Three panels, Durrow I B 11 and Clonmacnoise V B 13 and D 13, all situated on the butt, are decorated with a single register showing a pair of beasts surrounded by branches with one or two traces of berry bunches, inhabited vine-scroll thus being depicted. The first two may be closely compared since both show confronted winged quadrupeds but Clonmacnoise V D 13 is too weathered to recover any detail. These three panels may be regarded as variations of the inhabited vine-scroll motives already discussed (see p 72). The first two may be particularly compared with the confronted quadrupeds which form the bottom register of the inhabited vine scroll on Kells South (Fig. 18) and a further close parallel may be cited with a panel on the upper part of the back of the Corp Naomh (Mahr 1932, Pl. 69). This piece of metalwork, which is possibly a bell reliquary, was found at Templecross, Co Westmeath. It is multiperiod but the panel in question seems to belong to the earliest phase which has been variously dated to the ninth, tenth or eleventh centuries (Henry 1967, 125-6 ; Raftery, J. 1940, 157) although Máire MacDermott (1957, 192) has suggested that it may be about the same date as St Mel's Crozier on account of similarities in the interlace ornament. She ascribes the latter to the mid tenth century. The Corp Naomh shows two confronted quadrupeds each encircled by a branch which stems from a half circular 'root' at the bottom of the centre of the panel. The fronds terminate in round foliage buds. The panel is executed in very low relief using an almost engraved technique which, as Françoise Henry noted (1967, 126) has much in common with Vernacular Style engraved metalwork (see Appendix 2). Further comparisons may be made between the confronted winged quadrupeds on Durrow I B 11 and Clonmacnoise V B 13 and the solitary winged quadrupeds found on Tihilly A 5 and Monasterboice West (Macalister 1946, Pl. XVI.5).

f) Frets

There is very little fret ornament on these two monuments. What there is is executed in very low relief and the patterns are impossible to reconstruct precisely. Firstly, diagonal fret patterns are used to ornament the faceted panels at the ends of the horizontal cross arms on Clonmacnoise V B 5 and Durrow I B 4. This is paralleled exactly on Monasterboice West (Macalister 1946, Pls. XII, XIII) and further comparisons may be made with panels on Tihilly B 1 and the cross fragment from Monasterboice (Roe 1954, Pl. X). In addition, on Clonmacnoise V D 1 is a composite pattern combining bossed spirals with fret ornament. There are other patterns of this type on Monasterboice West and Kells West (Macalister 1946, Pl. XVI.1; Roe 1966, Pl. XVIII).

Conclusion Therefore on Clonmacnoise V and Durrow I abstract ornament is little used and in some instances, for example Clonmacnoise V B 12, the execution of the pattern is not very accomplished. The majority of motives may be seen as a continuation of earlier types although much of the vigour has been lost. The ornamental repertoire is closely paralleled on Monasterboice South and West and further interesting comparisons may be made with Tihilly and Kinnitty I.

6) The Inscriptions

Both monuments have fragmentary incised inscriptions on two faces of the cross butt. The inscriptions on Clonmacnoise V A 16 and C 16 are particularly important since much of the currently accepted chronology of early Christian Irish sculpture depends upon their interpretation. George Petrie was the first to attempt their reconstruction, three slightly different versions being put forward. The first is

A 16 :- OROIT DO FLAIND MAC MAILSECHLAIND
'A Prayer for Flann, son of Maelsechlann'

C 16:- OROIT DO COLMAN DORROINDI IN CROSSA
AR IN RI FLAIND
'A Prayer for Colman who made this cross for
King Flann'

(Petrie 1845, 269-70)

The second, in a book edited after Petrie's death by Margaret Stokes, gives:-

A 16:- OR DO FLAVND MAC MAELSECHLAIND

C 16:- C]OLMAN DORRO [INI IN CROI] SSA AR IN RI
 [FL]AND (Petrie 1872, 42)

and in the accompanying illustrations (op cit, Figs. 87-8) the rendering is again slightly different (Fig. 35). These interpretations caused Stokes and Petrie to link the cross with Colman, Abbot of Clonmacnoise and King Flann, who the annals record as having built a church at Clonmacnoise in 908.¹⁵ This association has been accepted by the majority of writers since (Harbison 1979, 179). However Peter Harbison (op cit, 180 ff) has recently called Petrie's readings into question by drawing attention to illustrations of the cross drawn by Blaymires in 1738 (Ware and Harris, 1739, II, 46; Harbison 1979, Pl. III) where the inscriptions are already depicted as fragmentary¹⁶:-

A 16:- INDM
 C 16:- OD (?) :NANDORRO
 DRCN(?)AR

The obvious inaccuracy of Petrie's reconstruction has further spurred Harbison to attempt his own version of the inscription on C 16:-

OR DO RO]NAN DORRO [IGNI T CHRO] SSA AR
 [CUIMNE FLAI]ND¹⁷

'Pray for Ronan who erected this cross in memory of Flann'.

However, he conceded that the only letters now identifiable without doubt on A 16 were NDM̄. He has gone on to link the figure of Ronan with an enigmatic Abbot of that name at Clonmacnoise who resigned his post in 823 (C.S.AU 822) but is still described as Abbot in the annalistic entry giving his obit in 844 (CS;AU 843). He connects Flann with a Munster vice-abbot Flann, son of Flaithbheartach who was drowned in the Shannon in 823 (CS) or, alternatively, 834 (AFM).

The problem with all these different interpretations is that, because so few letters are now legible, the attempt to resort to pure speculation or the reconstruction of the inscriptions in order to fit them with historical events gleaned from the annalistic sources has been too great. It would be much better to make a re-appraisal of the surviving letters without attempting a complete reconstruction.

Taking the inscription on C 16 first, it seems possible to read NAN DORRO on the top line. On the second line AR is fairly clear and

the fragmentary letters before perhaps SSA. On the bottom line only the D may be read. Kenneth Jackson has suggested to me (Letter January 1981) that the only word which may be identified with any probability at all is DORRO [INE] meaning 'made' although he admits that the use of the double 'R' is not usual. This word is definitely in use by c 900 and very probably before.

The inscription on A 16 is extremely fragmentary only NDM̄ being now identifiable.

Thus it does not seem possible to link these inscriptions with any historical figures in the annals. Epigraphically Professor Jackson would prefer a ninth century date for the inscriptions as a capital 'R' is used but the amount surviving is so little as to make this rather uncertain.

The inscription on Durrow I A 12 is very fragmentary. Macalister (1949, 40) reconstructed the first line to show

[OROI]T DO T[IG...]

but the basis on which this was attempted seems groundless. Margaret Stokes (1898, 11) however suggests

[OR D]O DUBT[ACH]

and this seems much nearer the mark. The actual letters now visible are DUBT possibly preceded by an O. The letters DUBT may be reconstructed to form the personal name Dubthach (Jackson, letter Jan. 1981). Margaret Stokes (1898, 11) linked this personal name with Dubtach, a steward of Durrow who died in 1010 (A.F.M.) while Françoise Henry (1967, 139) thought it was more likely to be another man of the same name who governed the Columban paruchia including Durrow from 927-938.¹⁸ However, it could equally well refer to some other figure of this name.

The inscription on Durrow I D 11 is also extremely fragmentary. Macalister (1949, 40) produced what he described as a 'most tentative description':

OR DO AED
 OCUS DO
 [B?] AN GAD -
 - AN[DO RI]G
 NI IN CHROIS

This cannot be correct as the majority is now illegible. Margaret Stokes (1898, 11) suggested:-

Fig 35 CLONMACNOISE V: INSCRIPTIONS ON A 16 AND C 16

ORDOFICINOMC
-hlc

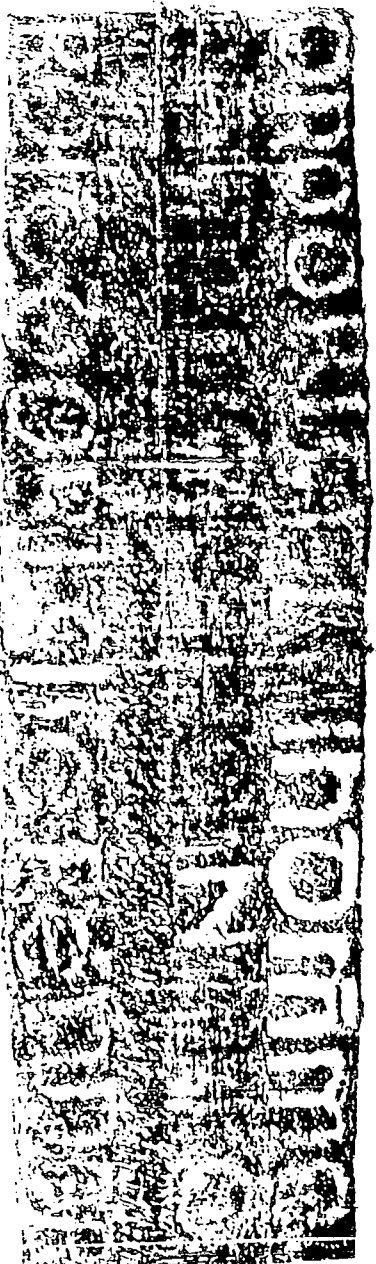

COLMANNONNO
MTCORSSCAR
MANNONNO

After Petrie

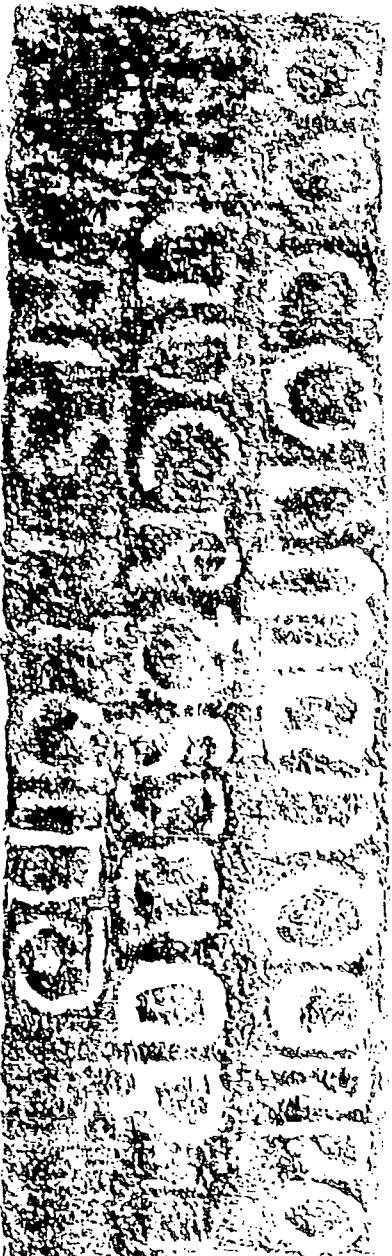

After Ó Murchadha

OR DO M
 ARO
 RT

|?G|

The only letters which may now be read are:

OR DO M
 |R?| O
 T |I?|

M should indicate the first letter of a personal name but nothing else may be added. Professor Jackson suggests that the Durrow inscriptions on the basis of epigraphic evidence would also seem to be ninth century.

Therefore at the moment the inscriptions on these two crosses cannot be considered very helpful in attempting to establish the date of the monuments.

7. The Dating of the Monuments

As has been shown by comparisons of the figural panels and the ornament Clonmacnoise V and Durrow I are undoubtedly Southern outliers of the Northern 'Scripture' cross series. They show particularly close affinities with the South and West crosses, Monasterboice.

The problems associated with the inscriptions on Clonmacnoise V and Durrow I have already been discussed and their use as dating evidence at this time has more or less been discounted. However, the inscription on Monasterboice South is still completely legible and must be assessed as a potentially valuable piece of information with regard to the dating of the group. On the butt on the West face Macalister records the following words:-

OR DO MUIREDACH LAS
 NDERNAD T
 CHROS

'Pray for Muiredach who caused this cross to be made'
 (Macalister 1949, 31-2; 1946, 38).

In fact upon checking this I can only read:

OR DO MUIREDACH LAS
 NDERN
 RO

but this makes no difference to the following argument.

The difficulty is that the name Muiredach may be linked with two known personalities and a third completely unknown Muiredach remains an unlikely but faint possibility. The first of these is recorded as Abbot of Monasterboice and his obit is given in the annals as 844 (AFM). Otherwise nothing is known about him. The second has usually been considered the more likely candidate (Henry 1933, 16). It is thought that he became Abbot of Monasterboice c 887. (AFM) and his obit is recorded in 923 (AU 924 (recte) 923 ; AFM 922). He was also vice-abbot of Armagh and undoubtedly an important churchman in the history of the period.¹⁹ Clearly it is easier to associate a cross of this magnificence with a well known figure who is likely to have been a patron of the arts. His career also forges a link between the monastery of Armagh, undoubtedly a very important intellectual centre (Kennedy 1929, 377), which has a cross with figural iconography still extant (Roe 1955, 108-111, Pls. XI, XII). However, one must ask whether there is other evidence to support this supposition.

Firstly, from the historical point of view, the idea that Monasterboice South should have been erected by the second abbot rather than the first definitely seems more likely. The 830s and 840s (Hughes 1966, 199; 1968, 25) are just the years that the Viking raiding is particularly heavy (see Appendix 2) and, although only one raid is recorded on Monasterboice c 850 (Lucas 1967, 221²⁰), Clonmacnoise is badly affected in this period, being raided by the Norse in 834, 841 and 844 (twice) (op cit, 217) as are many other Irish monasteries. Therefore it seems unlikely, in a period when monastic morale must have been at a low ebb, that monuments, which were major artistic projects, would have been produced. Although one could argue that the raids caused the concentration of artistic effort to move away from metalworking, which was easily plundered, in favour of a more durable medium, one should also consider the general instability of the period and ask whether it is likely that the monasteries would have concentrated on sculptural achievement at this time when the whole monastic system must have been severely rocked?

However, the period when the second Muiredach was Abbot c 887-923 included a time of respite from the Viking onslaught. Kathleen Hughes (1968, 25) noted that the incidence of raids recorded in the analistic sources tails off after 881 and is not really renewed until the 920s. Surely this generation of relative peace would have enabled the

monasteries to contemplate once more the erection of monumental stone crosses?

Secondly, one must consider the art historical evidence. As has already been stressed with the figural iconography above it is very easy to make general comparisons with the ivories, metalwork and manuscripts produced on the Carolingian Continent which were doubtless brought to Ireland by travellers as gifts or souvenirs. However, it is extremely difficult to find more detailed parallels or to show any link with a particular workshop or period of production. As far as can be seen the majority of the iconographical parallels seem to be present in the Carolingian material by the end of the first half of the ninth century. It is certainly possible that models could have been brought to Ireland at an early date and then immediately adopted by the Irish. However, a certain time lag seems equally likely, a period in which the new iconography might be absorbed and then actually put to use by Irish artists, who, in the main, seem to have been rather conservative. It is interesting to note that, although there are some Irishmen such as Dicuil present in the intellectual circle at Charlemagne's court at the beginning of the ninth century, with the Norse onslaught on Ireland this number is greatly increased and it was during the middle and later part of the century that Irish influence in European scholastic circles reached their zenith (Kenney 1929, 554, 531, 545). The most important figures of the period were Johannes Scottus Eriugena; who lived at the palace school of Charles the Bald, arriving at least as early as 845 and remaining there until c 870 or later (op cit, 571) and Sedulius Scottus who was active at the Court of Lothar in Liège from c 845 - c 860 (op cit, 554). The increased presence of Irish monks on the Continent might well have resulted in an increased number of Carolingian art works arriving in the homeland which could have provided models.

In Ireland the period of the first Viking onslaught has always been considered disastrous for ornamental metalworking (Henry 1975, 61) although, as has been suggested (see Appendix 2), the raids do not become very serious until the 830s. However, apart from minor pieces, the metalworking does not really seem to recover until towards the end of the ninth century, the period of the Forty Years Peace. Maire MacDermott (1955, 78ff, 108-9) has argued cogently for a revival in ornamental metalworking during the late ninth and early tenth centuries. She has shown that the first phase of the Kells Crozier shrine and that of St. Dympna (1957) may be attributed to this period, that of St. Mel probably being slightly later. The ornament of these croziers is essentially Irish and the motives used may be seen as developments of those found in the

ornamental metalworking of the Vernacular Style. However, it is possible to trace some outside influence from Anglo-Saxon and Carolingian sources. This metalwork therefore would seem to stem from a similar milieu to that of the 'Scripture' crosses and one or two comparisons in ornamental detail between the two have already been noted. Some manuscript illumination also seems to have survived from this period. The Book of MacDurnon (Canterbury, Christ Church Lib.), which shows certain resemblances in the Evangelist figures with those on Clonmacnoise V and Durrow I, cannot be precisely dated but was in existence during the lifetime of Maelbrigte, a contemporary of Muiredach, who became Abbot of Armagh c 888 and died in 927 (AFM 925 (recte 927)). Françoise Henry (1960, 27ff) also attributes the Cotton Psalter to the early part of the tenth century, unfortunately mainly in analogies with the iconography of the 'Scripture' crosses.

Thirdly, another useful line to follow is to examine the artefacts depicted on the crosses themselves. The majority of these are too weathered to be of any help in assessing the date of the monument. However, there is one exception, the sword type, and this is crucial to the argument for the later dating of these crosses. The swords shown in the Arrest scene on Monasterboice South (Macalister 1946, Pl. VII.21) are very clear. They have a central groove and this is also found on other representations of swords on the 'Scripture' crosses. The pommel of the sword belonging to the right hand soldier is half circular. These characteristics would tend to suggest that these swords are of Viking type as these features are common on Viking swords found in Ireland (Bøe 1940). Some earlier Irish swords have a central groove but this is rare (Hencken 1950-1, 92). However, a problem which arises in identifying the swords represented as Viking is their length. The length of a Viking sword seems to average out at about 85-90 cm (Bøe 1940) and this seems longer than those represented. However, this shortening may be due to lack of space on the carved panel. Overall a Viking sword type seems most likely. The implications of this are important as it seems unlikely that the Irish would have adopted Viking sword types by the 840s; however, by the end of the ninth century this seems perfectly possible.

Therefore, the historical and artefactual evidence and, to a certain extent, the art historical would all tend to support the view that the inscription on Monasterboice South refers to the Muiredach who was Abbot c 887-923 and this cross would seem to date to the late ninth or early

tenth centuries. One would expect the crosses Clonmacnoise V and Durrow I to be of a similar date. It follows from this that the inscription on Clonmacnoise V C 16 could refer to Colman, Abbot of Clonmacnoise c 904 - c 924 (AU; AFM) and that on Durrow I A 12 to Dubtach who was head of the Columban paruchia from 927-938.

It is also important to establish whether any kind of relative chronology may be offered for the 'Scripture' crosses. As has already been suggested (p204) the group seems to be initiated by the South Cross Kells which shows a mixture of figural scenes and ornament but the carved face is not divided into panels which is a characteristic of the 'Scripture' cross group. The Crucifixion is not placed on the crosshead of the West face and the Christ type is not that common on the Carolingian Continent. There is no Last Judgement; the crosshead of the East face is decorated with a roundel, but the Maiestas Dei is placed on the West face of the crosshead. In the next development that can be detected the crosses become more monumental. The sculptural face is divided into panels but at this stage the shaft is only three or four panels tall. The Crucifixion is placed on the crosshead of the West face and the Carolingian Christ type is depicted. The Last Judgement is found on the East face of the crosshead. Little ornament is used. The crosses which fall into this category are Monasterboice South, Armagh, Clonmacnoise V and Durrow I. It is difficult to be sure how the cross at Armagh would have looked when it was complete. However, the quality of Monasterboice South and the complexity of the iconography is undeniable. The iconography on Clonmacnoise V and Durrow I is much less complete. The base of Durrow I is undecorated and the details of the ornament of the panels at the ends of the horizontal cross arms on the narrow faces of both crosses are almost identical to Monasterboice West. This would tend to suggest that Clonmacnoise V and Durrow I may be slightly later than Monasterboice South. The next development of the 'Scripture' crosses seems to come in the North. These crosses, for example, Monasterboice West, Arboe, Donaghmore and perhaps Kells West are taller and more slender. The crosshead is separate from the shaft. The number of shaft panels increase and there is a junction or ornamental collar part of the way up the shaft. The iconography is much the same but the scenes are frequently much abbreviated. The group would seem to play itself out finally with outliers at Drumcliff, Co Sligo, and Boho, Co Fermanagh (Henry 1970, 125-6). The actual time expanse covered by this

group of crosses seems at present almost impossible to determine.

Ch. X. FOOTNOTES

1. In some instances descriptions of these may be rather highly coloured (Morris 1979, 10). See also Appendix 2.
2. CS 908: 'The stone church of Cluain-muc-Nois was built by Flann, son of Maelsechlainn, and Colman Conaillech'. Other annalistic refs. = AFM 904 and A. Clon. 901 where the church is referred to as the 'church of Kings'.
3. AFM 957: 'The Termon of Ciarán was burned this year, from the High Cross (crois aird) to the Sinainn, both corn and mills'.
4. AFM 1060: 'The Eli and Ui-Forgga came upon a predatory excursion to Cluain-mic-Nois; and they took prisoners from crois-na-screaptra, and killed also two persons'. See also A. Clon. & A.Tig. 1060.
5. Porter also suggested two further representations of this scene on Arboe and Donaghmore. These are more likely to show the Wedding at Cana (Roe 1956, 83, 86) although the panels are so weathered that it seems uncertain whether any secure identification should be attempted.
6. It is interesting to note that the representation of this cross may indicate Irish knowledge of the Apocryphal Gospel of St Peter where, at the moment of Resurrection, a great cross reaching to the skies appeared from the tomb (Fragment 1, v 40-2).
7. For example:-
 - a) The Fis Admonáin, which was probably written during the ninth, tenth or eleventh centuries, says:

'So soon as Elias opens his book in order to instruct the spirits, the souls of the righteous, in the form of bright white birds, repair to him from every side'.
(Boswell 1908, 25, 46)
 - b) Vita Prima Sancti Brendani XXVI-XXVII (Plummer 1910, 113-4).
8. This interest in the Passion and death of Christ as opposed to His victory over death may first be seen in the early ninth century in the writings of Candidus who was possibly a monk at Fulda. In Opusculum de Passione Domini he compares the Fall and the Crucifixion, the latter being the salvation of mankind. He suffers the most terrible death at the hands of the Jews; the inclination of His head signifies His meek acceptance (Coatsworth 1979, 77). The inclination of the head is also a feature of the Crucifixion on Durrow I and Clonmacnoise V.
9. This small winged devil differs considerably from the beast headed monsters which represent devils in Hiberno-Saxon sculptural depictions

of the Temptation of St. Anthony (Mason 1942).

10. The St. Matthew page on this manuscript (f4V) shows the Evangelist with a sword with a triangular pommel placed between his knees (Hughes 1980, 32, Pl. III). This could either be a misunderstanding of a tau crozier or an inkstand.
11. See Footnote 1.
12. 'Then Ciarán planted the first stake in Cluain, and Diarmait, son of Cerball, was along with him. Said Ciarán to Diarmait when setting the stake, 'Let, O Warrior, thy hand be over my hand, and thou shalt be in sovrantry over the men of Ireland'. (Stokes, W. 1890, 276)
13. Porter (1931, 27) thought the scene was also represented on Graiguenamanagh I A 6 but this is undoubtedly the Fall (see p193).
14. Evidence of similar affection is also to be found in the literature, the most famous example of which is the oft quoted Pangur Bán (Meyer 1911, 83-4).
15. See Footnote 1.
16. The inscription on A 16 is here incorrectly shown on the North face.
17. Professor Jackson (Letter Jan 1981) tells me that part of this reconstruction is grammatically incorrect. For example 'do' is not a relative particle as Harbison has claimed (1979, 183) and there is no such word as 'crossa' meaning 'cross'.
18. 'DUBHTHACH Coarb 927-38 Obit Oct. 7th. Son of Duban of the race of Conall Gulban,--- He was abbot of Raphoe as well as Hy (Iona) and is styled by the Four Masters, Coarb of Columcille both in Erin and Alba' (Reeves 1857, 393).
19. AU 924 (recte 923): 'Muiredach son of Dommach, tanist-abbot of Ard-Macha and high steward of the Ui Neill of the south, and successor of Buite, son of Bronach - the head of the council of all the men of Bregh, lay and clerical died, on the 5th of the Kalends of December'.
20. The reference to this raid is not taken from the usual analistic sources but from a list of raids recorded with their approximate dates in the Cogadh Gaedhel ne Gaillaibh.

Addendum

Two new articles now support an early tenth century date for Clonmacnoise V (Henry 1980; Ó Murchadha 1980). Dómhnall Ó Murchadha has painstakingly recorded both the inscriptions on this cross with the aid of squeezes and rubbings (op cit, Fig. 10) (Fig 35) and these have been read and translated by Professor Jackson (Letter April 1982).¹

The sense of the inscriptions is continuous beginning on the west face:

A 16 ORDORIGFL [A] INDĪMA
 [ELESCHL] AIN [N] O
 ROITDORIGHERENNOR

C 16 DOCOLMANDORRO
 or [NAI] ← [INI] INCROSSAAR
 |IND|RIGFLAIND

'A prayer for King Flann son of Maelsechlainn...,
 a prayer for the King of Ireland. A prayer for
 Colman who made this cross for the King Flann.'

Colman was abbot of Clonmacnoise c 904 - c 924 (AU; AFM) and Flann's obit is recorded as 914 (AFM) or 915 (recte 916, CS). In addition Françoise Henry has suggested (1980, 44) that the word DORROINI (DORRONAI)² could indicate that the cross was actually carved by Colman.

Footnotes

- 1) Surprisingly no translations are attempted by either Françoise Henry or Ó Murchadha.
- 2) She records DORROINI (DORRONAI) as 'DO RIGNI, or some approximate form':

Chapter XI MISCELLANEOUS MONUMENTS

There are a number of crosses and other fragments which do not fit into the main groups already discussed. These are dealt with here in alphabetical order.

1) Clonmacnoise VI

This little known sculptural fragment is probably the piece identified by Françoise Henry (1965, 143) as coming to light during repair works at the monastery in 1957.

The monument is not complete. It is broken at the top but from the way it tapers at the top of Face D it seems likely that what remains is the shaft of a small cross. The taper would seem to indicate the point where the shaft narrows at the top before it broadens out to form the horizontal cross arm. The form of the crosshead is impossible to guess at but there is no indication on Face D that there was ever a wheel. The shaft appears complete at the bottom indicating that the cross could only ever have been small. It is interesting to note that the depth of the shaft is precisely half the width.

The interlaced beasts on Face A are carved with great elegance in low relief. The species of beast is not clear but the manes and tails make them look lion-like. The details of these beasts may best be compared with Hiberno-Romanesque architectural ornament and the best parallels may be made with the capitals of the half columns on the chancel arch of Tuam Cathedral, Co Galway (Leask 1955, 153-4; Henry 1970, Pls. 86, 87). These are heads placed face on and it is not clear whether they are animal or human but the curly mane of hair and the hatched areas are similar to Clonmacnoise VI and they are executed in a similar low relief style. Comparisons may also be made with a face on lion-like beast with prominent teeth on the porch at Freshford (Leask 1955, 154). The difficulty is that the form of the beasts on the Romanesque churches and Clonmacnoise VI is completely different and there does not seem to be more

precise parallels for beasts of the Clonmacnoise type. The actual form of these beasts seems to have more in common with some other motives found on the Clonmacnoise Group sculpture, the confronted beasts with interlocking beaks on Bealin A 2, the confronted interlaced beasts with spiral bodies on Clonmacnoise I B 3 and the lions and griffins popular in this group as a whole (see pp62,66,81).

The interlace on faces B, C and D is fairly competently carved apart from mix-ups on the right hand side of the top two registers on Face C where the Basic C elements have become reversed and a Simple F element has been formed below. The patterns are all carried out on a square grid using a 2.5cm unit measure and a 1.25 cm approx. strand width. There are indications of a median line on the strand in some places on Face C. This is not continuous and for this reason could indicate the original marking-out of the pattern. Both the patterns, Basic C and Basic E, and the unit measure are found on the other monuments at Clonmacnoise (see Figs. 8 and 9).

This monument is quite difficult to understand. Françoise Henry, if her reference (1965, 143) to the monument has been identified correctly, places it with the Clonmacnoise Group (Ch. IV) but John Hunt (1967, 130) regards it as late twelfth century. The problem is the dichotomy between the interlace on Faces B, C and D and the beasts on Face A. If one only saw the interlace panels one would be quite happy to place this monument with the Clonmacnoise Group and assign it to a similar date (see p 92). However, the stylistic details of Face A, although the general form and layout of the beasts may be compared with the Clonmacnoise Group, are totally different and undoubtedly have their parallels with Hiberno-Romanesque architectural sculpture. There are no signs of recutting and so one is forced to suggest that the entire monument is of this date and that the sculptor, while executing part of the monument in a Romanesque style, also seems to have picked up the threads of a much older type of ornament presumably from the sculpture he saw around him. Interlace could still be competently carried out in the Romanesque Period, for example on the cross at Kilfenora, Co Clare, and the doorway at Clonfert (Henry 1970, Pls. 52, 68, 69). A more precise date for the monument is more difficult but the chancel arch at Tuam and the porch at Freshford have been dated by Leask (1955, 154) to his third phase of Romanesque architecture, perhaps c 1170, and it seems possible that Clonmacnoise VI could be of a similar date. If this is so it is interesting to note that the carving of shafts and crosses lasted a very

long time at Clonmacnoise and that this may be amongst the latest monuments of this type in Ireland.

2) Dunnamaggan

This small, rather crudely carved cross has only been discussed in any detail by Carrigan (1905, IV, 35-7) and Lahert (N.D, 4-6). The latter regarded it as possibly Early Medieval but suggested that the figures could have been added at a later date.

The form of the cross is problematic since there are no parallels. Overall it gives the impression of having been carved by someone who was not very familiar with how to carry out the conventional wheelhead cross.

The most diagnostic feature is the figure carving. The figure of Christ Crucified is set in its customary position on the West face of the crosshead (see p210). The figure is small, unaccompanied and, curiously, the area round it has been carved away to form a vaguely cruciform shape. The figure of Christ appears erect, the arms are raised and the head tipped towards the left. The type shown would seem to be that which developed during the Carolingian period (Schiller 1972, 140ff) (see p211) and lasted throughout the Middle Ages. Since no details of the carving survive it is not possible to be more precise.

The four figures on the shaft, three of which are recessed under arches, are not precisely identifiable. That on A 2 is likely to be an ecclesiastic because of his clothing, his staff and his right hand is raised in benediction. Lahert (N.D., 6) suggested it was St. Leonard, the patron Saint of the site, but there is no sound evidence for this. Carrigan (1905, IV, 37) suggested that the figure on C 2 could be St Catherine though this seems unlikely as it is not possible to see her wheel. These figures find their closest analogies with weepers on tombs in England. These are small figures shown face on set under arches and they have their origins in representations of the funeral cortège (Stone 1955, 145-6). Such figures are first introduced from France into England at the end of the thirteenth century and early examples may be seen on Edward Crouchback's tomb in Westminster Abbey and the Tomb of Thomas de Cantilupe in Hereford Cathedral (op cit, Pls. IIIA and B, 118 B). The former shows the newly introduced ogee arch which is paralleled very crudely on Dunnamaggan A 2. The latter shows soldiers with shields; the figure on Dunnamaggan D 2 is also likely to be a soldier with a shield.

Unfortunately Ireland has few early examples of tombs with weepers; the majority are very late, belonging to the fifteenth century, and the style of carving is totally different (Hunt 1974, I, 100ff).

The only abstract ornament is very crude. The boss and roundels on C 1 are vaguely reminiscent of crosshead designs on monuments like Ahenny I (see p 96). However, the dog's tooth effect has its roots in the Romanesque period (eg. Leask 1955, Fig. 55).

Therefore the figural sculpture is undoubtedly High Medieval and could perhaps be fourteenth century. The more difficult question is whether the cross form is of the same date. Certainly there is nothing in the abstract ornament to suggest it is Early Medieval and the form suggests a time when knowledge of the Early Medieval cross shape had been largely forgotten. More than that it is difficult to say.

3) Durrow II and III

Unfortunately both these monuments are probably missing.¹ It therefore seems difficult to add anything significant to Françoise Henry's discussion (1963). However, the evidence she has already put forward will be briefly reviewed.

a) Durrow II

The Original Form of the Monument Clearly this crosshead has been recut to some extent in order to make it reusable as a gable finial. However, it is difficult to agree with Françoise Henry's view (op cit, 83) that the horizontal cross arms were originally much longer. Without being able to examine the monument, it would seem that, if the horizontal cross arms were of any greater length, the proportions of the crosshead would be extremely peculiar. The armpits of the cross are also of an unusual shape. They may originally have been of the 'usual curved type' as Françoise Henry says and therefore may have been recut. However, that more than a sliver was removed seems unlikely, since the perimeter roll moulding survives to some degree round most of the circumference of the monument, the exception being the top right hand armpit on Face C. A wheel is by no means an impossible original feature and if this had been present perhaps the original form of the crosshead might have been similar to Tihilly (see Fig. 30). The deep socket on the upper cross arm certainly suggests a capstone of some kind. Whether it was originally

intended to stand in the crossbase, Durrow III, is now impossible to be sure of. However, it seems likely that Durrow II may have been very much taller than the surviving fragment would suggest; indeed a cross of similar proportions to Tihilly is not impossible.

The Decoration The Crucifixion on Face A is likely to have been the original West face of the crosshead as on monuments which survive in situ it always appears in this position (see p210). The area available for sculptural embellishment is severely limited and the crosshead is dominated by the figure of Christ shown naked, beardless and erect, a type which was derived from the Carolingian Continent and which has already been discussed in some detail in connection with the Southern 'Scripture' crosses (see p210). However in this instance Christ's head does not appear to tip downwards towards the left and in this it may be compared with Tihilly and Drumcullin (see p180). Below Christ's armpits are two roundish shapes carved in relief. Françoise Henry (op cit, 84) has suggested that the sun and moon are intended. However, this seems unlikely as on Irish Crucifixions the figures of Stephaton and Longinus are almost ubiquitous (see p212). This is the proper position for them whereas one would expect Sol and Luna to be placed above Christ's arms (see p87). The heads of the thieves are also a slight possibility although these are not very common on the 'Scripture Crosses' only being depicted on the expanded versions of the scene on Monasterboice South and West (Macalister 1946, Pls. IX, XVIII), Armagh and Clones (Roe 1955, 110). Longinus and Stephaton seem most likely as they are represented in a somewhat fragmentary way due to lack of space on some other crosses, Tihilly for example, and on Drumcullin there are similar slight blobs under Christ's armpits (see p180).

Above Christ's head is an area of relief which would seem to be a bird in profile. This may be compared with a similar bird on Durrow I (see p213).

On Face C is a single figure, possibly in a seated position, holding a crozier. The fact that he has a crozier suggests Christ in Judgement or Majesty, the most usual figural representation in this position on the 'Scripture' crosses (see p218); is not the scene depicted here. Françoise Henry (1963, 84) has suggested it may represent a bishop of the type shown on the cross at Dysert O Dea and the 'Doorty' Cross, Kilfenora, Co Clare, which probably date to the first half of the twelfth

century (De Paor, L. 1955-6, 53ff, Fig. 5, Pls. II, V). There is a similar figure on the cross at Cashel which is of a similar date (Leask 1951, 14-18) and a further possible parallel is provided by Roscrea II although, in this instance, the figure is fragmentary and therefore its identification with a bishop is purely conjecture. However, there are differences between these and the figure on Durrow II. Those at Dysert O Dea and Kilfenora wear mitres. The Durrow figure does not. Kilfenora and Cashel show the bishops in an attitude of benediction.² This also is not apparent on Durrow II. Thirdly, the bishops on Kilfenora, Cashel and Dysert O Dea crosses hold a crozier of the Continental type (De Paor, L. 1955-6, 63-4); the Durrow II carving is very weathered but an Irish 'walking stick' type crozier as opposed to a Continental spiralled one would seem the most likely. The question arises as to whether the figure on Durrow II really represents a bishop in the sense that those on Kilfenora, Dysert O Dea and Cashel undoubtedly do or whether some other figure may be intended. For example Evangelist figures also sometimes carry a crozier as may be seen on Clonmacnoise V B 10 and D 10 (see p228). The curious area of relief which appears to stand out behind the figures' left arm could perhaps even be a completely garbled version of an Evangelist symbol. The possibility that a saint could be represented also cannot be ruled out. Therefore, while Françoise Henry's identification remains the most likely, the possibility of an Evangelist or a saint cannot be ruled out.

Two types of abstract pattern are represented. The first, consisting of a low boss from which serpentine creatures are emanating, is used as a filler at the ends of the horizontal cross arms on Face A. These are very similar to those found on Clonmacnoise V and Durrow I and elsewhere amongst the 'Scripture' crosses (see p243). The second is a fine thread interlace (the crossface is too weathered for the precise pattern to be reconstructed) in the same position on Face C. Interlace of this type is not very common. As Françoise Henry says (1963, 84) it is used on the late 'Scripture' cross from the Columban foundation of Drumcliffe, Co Sligo, and it is also found on the cross from Inis Cealtra which is dated securely by inscription to the early twelfth century (Henry 1970, 123-4, Pls. 50, 51).³

Conclusions It is a great pity that this monument is so fragmentary because it seems to stand at an important juncture in the development

of the freestanding cross between the end of the 'Scripture' cross series and the beginning of the Urnes monuments, Roscrea II, Mona Incha II, Cashal and Tuam and the limestone crosses of Aran and Clare (Henry 1963, 84). The later groups are dated with some confidence to the first half of the twelfth century but where the end of the 'Scripture' cross series lies is impossible to say. The style of Durrow II is certainly for the most part, that of a 'Scripture' cross. It does not have the long robed Crucifixion type of the twelfth century monuments and the serpent and boss patterns are also characteristic of the 'Scripture' crosses. The interlace perhaps indicates its transitional position but what the dating ultimately hangs on is the identification of the figure on Face C. If a bishop is intended surely this monument must belong to the early part of the twelfth century when the reformation of the Irish church along diocesan lines was in full swing (Hughes 1966, 263 ff), the period when a new prominence was given to the figure of the bishop, both in ecclesiastical organisation and in art (De Paor, L. 1955-6, 61-2)? At no other time would there have been the need to place the figure of a bishop in such an important position on the crosshead. If this identification is correct Durrow II demonstrates the survival of the 'Scripture' cross style for some considerable period after its inception, indeed perhaps for as long as two hundred and fifty or three hundred years. However, if an evangelist or some other ecclesiastical figure is intended, the fragment could be very much earlier and more truly part of the 'Scripture' cross series.

b) Durrow III

Very little can be said about this base as it seems to be undecorated. However, the shape and lack of decoration suggest it is rather similar to Durrow I (see p 204).

4) Gallen Priory I and II

The two pieces discussed here do not fit into the mainstream of shafts and freestanding crosses discussed in this work. However, they are important as they demonstrate other related classes of sculpture.

Gallen Priory is situated on the bank of the River Brosna about eight miles South East of Clonmacnoise (Map V). The monastery is fairly well recorded in the documentary sources (Armstrong 1908a, 61; O'Donovan

1864, 342-3; Archdall 1786, 396) and it is interesting to note that its founder, St. Canoc (sometimes called Mochonóg) was of British origin. This link appears to have been retained as, when the monastery was destroyed in 820, it was restored by a group of Welsh monks (ibid).

This monastery is one of the very few in Ireland to have undergone fairly extensive excavation. Various trial trenches were dug by Petrie and Sir Andrew and E.C.R. Armstrong (1908a) in 1907. The area was further investigated by T.D. Kendrick in 1934-5 (1939) and he found a later medieval church and an earlier cemetery with a large number of grave slabs. The quantity and variety of these slabs must testify to a monastery with a very active sculptural work-shop which seems to have maintained a rather different style from that at Clonmacnoise nearby (Lionard 1960-1, 146-8).

a) Gallen Priory I

The Form and Layout of the Monument This monument is unusual in that it is not a freestanding cross but rather a large scale freestanding cross slab. Such a form is unique in this part of Ireland but cross slabs of this type are more common in the North West and there are a few isolated examples from elsewhere (see p 25) (Henry 1940, 59; 1965, 123). The closest Irish parallel is provided by the slab from Fahan Mura, Co Donegal (op cit, Pls. 52, 54). Both slabs are dominated by crosses (op cit, 125) composed of a bold interlace mesh but there is one important difference; the faces of Fahan Mura are treated as a single unit while Gallen Priory I A has been divided into two distinct panels. The freestanding cross slab is much more common in Pictland where this type of sculpture predominated. Gallen Priory I has a superficial resemblance to some of the early Class II slabs but the closest parallel is provided by the later Class II slab from Northern Pictland, Rosemarkie I (Allen and Anderson 1903, III, Fig. 60). Both sides of this are divided into rectangular panels and the use of equal armed crosses set into abstract ornament and carpets of fret pattern are all found on both slabs. Isobel Henderson (1978, 49-50) has noted the similarity of the crosses on Rosemarkie I to manuscript carpet pages and this comparison would also seem applicable for Gallen Priory I (Henry 1965, 123).

Gallen Priory I is unusual in that only one of the major faces is decorated. In an art style which had a fear of empty spaces this suggests

that the back of the slab may not have been intended to be seen. It is possible, therefore, that it could have stood against a wall.

A tenon projects from the top of the slab. It is difficult to speculate on its use but two alternatives may be mentioned. Firstly, it seems possible that it may have supported some sort of capstone although this could not have been very substantial owing to the slender depth of the slab and the small size of the tenon. A likely form of capstone is perhaps suggested by the gable shape which forms the terminal to the upper crossarm of one of the broad faces of Fahan Mura (Henry 1965, Pl.52). The top of many of the Pictish slabs is a similar shape, for example Nigg, Aberlemno II and Glamis II (Allen and Anderson 1903, III, Figs. 72, 227A, 234A) (see p37). Such a capstone, which might equally be of wood or metal as stone, might then have been secured with the aid of a bolt passed through the hole beneath the tenon. Alternatively, it seems possible that Gallen Priory I could have been part of a very much larger structure held together with mortice and tenon joints and perhaps strengthened with bolts.

The slab is carved in low, rather flat relief; the field is cut away between the motives, much of the detail being picked out with incised lines. Similar techniques are used on the early Clonmacnoise monuments (see p65), to some extent Kilree and Killamery (see p142) and early Class II Pictish slabs such as Aberlemno II (op cit, III, Fig. 227A and B).

The sculpture at Gallen Priory is carved from sandstone, Armstrong (1908a, 63) claims that this is not local although Kendrick (1939,7) believed that it was. Gallen Priory lies on the junction of limestone and shale and bog alluvium but there is an outcrop of old red sandstone $3\frac{1}{2}$ miles to the North East and this may provide a possible source (O.S. Geology map, sheet 108).

The Ornament A 1 is dominated by a Greek interlace cross, its expanded terminals flowing into spirals. It does not have a wheel, although the introduction of the spirals into the corners implies an interest in filling up this area of the panel. It may perhaps be compared with spirals which are used in a similar way on St. Vigean VII (Allen and Anderson 1903, III, Fig. 278) (see p43). In Ireland the Greek cross with spiral terminals and decorated with a simple plaitwork mesh is a particular feature of two of the cross-slabs from Inismurray, Co Sligo (Wakeman 1892, Figs. 46, 47), and incised crosses with spiral terminals are fairly

frequently found on simple cross marked pillars and stones throughout Ireland (Lionard 1960-1, Fig. 8). The shape of the cross itself would seem to be derived from a cross of arcs which probably developed out of the degenerate chi-rho at an early stage (op cit, 111; Thomas 1971, Fig. 49). It is interesting to note that there are several other examples of the cross of arcs on the Gallen Priory grave-slabs (Lionard 1960-1, 112, Fig. 9; Kendrick 1939, 18) and therefore it seems possible that the type could be characteristic of this sculptural workshop. The interlace forming the cross shape is close-set and rather clumsy and it has proved impossible to determine either the precise pattern or how it was constructed. Several of the strands bifurcate and there is a small pellet in the centre of the cross. Robert Stevenson (1956, 93-6), following Shetelig (1948, 81-2), has suggested that these two features are characteristically Norse and he has used these as criteria for dating Fahan Mura, Carndonagh and Ardchattan in Argyll to the Viking period. Problems concerning the date of Fahan Mura and Carndonagh have already been discussed elsewhere (see p 25) and for Gallen Priory I this argument would also seem to be wrong since no trace of Viking influence may be traced on the rest of the ornament.

Françoise Henry (1965, 123) has suggested that the two confronted quadrupeds on Gallen Priory I A 2 are stags. However, they have pointed feline ears and no antlers and their tails, though much elongated, terminate in tufts. Both these features are characteristic of lions and in this light they may be seen as a different version of the lions found on the early Clonmacnoise monuments (see p 81).

The animal in the inset below may most probably be identified as a stag, its antlers stretching horizontally behind it. The object below its head could be a serpent. Stags are referred to as the enemies of snakes in both Isidore's Etymologiae and the Physiologus and the background to these texts is discussed in detail in connection with the stag on Tybroughney B 1 (see p162). There is a further parallel on Banagher A 2 (see p 85).

The stag is surrounded by a carpet of fret ornament. The practice of setting a panel within a field of ornament is also found on Ahenny I A 3 (see p106) and Rosemarkie I (Allen and Anderson 1903, III, Fig. 60). The fret pattern, the individual elements of which are outlined in low relief, may be compared with the carpets of fret ornament characteristic

of Kilree (C 10) and Killamery (A 1f.) (see p135). In Pictland Rosemarkie I again provides a good parallel.

Conclusions Françoise Henry (1965, 118ff; 1940, 59) has placed this cross slab amongst a group of widely scattered monuments which she sees as the direct antecedents of the freestanding cross. It has been argued elsewhere (see p25) that this group does not really hang together and it seems misleading to continue to regard Gallen Priory I as part of it. However, one should continue to recognise that it is a slab rather than a freestanding cross and that several comparisons have been cited between it and the Fahan Mura slab. It would also seem profitable to draw attention to the comparisons which have been made with the early Clonmacnoise monuments nearby, the Tybroughney shaft, the crosses at Kilree and Killamery and some of the Pictish Class II and III monuments, particularly Rosemarkie I. Gallen Priory I would therefore seem to fit into a similar context to these monuments and a late eighth or early ninth century date seems possible. Therefore, rather than being a forerunner of the freestanding cross as Françoise Henry (1965, 131) has suggested, it may be seen as a parallel development.

b) Gallen Priory II

Little can be said about this fragment since it is no longer extant and has not been recorded comprehensively. Despite this it ought to be considered briefly as it is clearly not an ordinary grave slab. Armstrong (1908b, 392) thought that it could have been attached to the top of Gallen Priory I but this is most unlikely. However, it does have a tenon at its lower end and the borders on the two vertical sides are a very unusual shape. They do not seem to be perimeter mouldings and it seems possible that they could be tenons of some kind as well. It seems probable that, as the interlace panel is incomplete, the fragment was originally taller. It is now impossible to know if this fragment of sculpture was originally used but some kind of panel for a shrine, screen or piece of furniture seem possible suggestions. The ornament is so fragmentary that it is of little help for the purposes of comparison although the quadruped on Face A may fall into the same category as the animals on Tybroughney and Roscrea I (see p160).

5) Kilkieran IV

As Helen Roe has said (1962, 35) this monument is 'extraordinary' and as a result very little can be said about it. The piece of stone from which the cross has been carved is a very unsuitable shape. Nevertheless the sculptor seems to have done his best with it and the result is a tall, slender monument with very short horizontal cross arms, no wheel and the armpits have been indicated on Face A by setting them into the actual width of the shaft. If there was ever a capstone it is impossible to suggest its original shape. The perimeter mouldings are cabled which makes the face of the cross appear recessed and in addition some of the panels are further recessed. It seems likely that these features are derived from the Ossory crosses as Kilkieran II and III are situated close by (see p 98). The shape of the armpits is also similar to these crosses. The ornament is negligible, consisting of recessed panels, panels defined by incised lines and an incised cross on Face C.

The peculiarities of this monument suggest it was carved by someone who had little knowledge of how to carve a large freestanding stone cross. For this reason one would suspect the cross is late, perhaps dating to a period when stone crosses were no longer generally carved. However, it is also possible that it is merely very crude and carved from an unsuitable piece of stone.

6) Leggettsrath I and II

These monuments⁴ have been discussed in some detail by Ellen Prendergast (1964) so little can be added here. However, it does seem apposite to review the evidence briefly.

The two fragments were found in 'The Church Field' (op cit, 5), a name suggesting that by tradition the site is associated with a church. Indeed, they stand inside a rath which could be all that now survives of some former ecclesiastical site. The townland name, 'Leggettsrath', refers to a thirteenth century tenant of Kilmalog House named Legget (op cit, 14) but, as Shearman has suggested (1874-5a, 395-7), it is possible that the site was originally associated with St. Malog, a fifth century missionary saint from Wales.

It is difficult to tell whether Leggettsrath I and II were originally part of the same monument. For this to be so I must have been considerably taller than it now is in order that the depth of the shaft should have tapered sufficiently in order to correspond with the depth of the crosshead,

II. This implies that the shaft of I was composite since it now has a socket in the top which indicates that an upper section of shaft would have to have been affixed and such a construction is not closely paralleled elsewhere.⁵ Overall the shape of I is unusual since it has a projecting plinth rather than a base, a feature which may be compared with Tybroughney (see p159). It is also odd that the Broad faces are not aligned East/West (see p 38) but rather North/South, perhaps suggesting that shaft is not in situ. It is also interesting to note that the ornament is found on the narrow rather than the broad faces.

The crosshead, Leggettsrath II, is rather crude and therefore the type is difficult to ascertain. It may be Type Ib⁶ (Fig.39).

There is little ornament on either I or II, perhaps because of the hardness of the granite from which they are carved. The ornament on Leggettsrath II is restricted to a Latin cross on Face B, not very helpful for comparative purposes not only because of its simplicity, but also because this motif is not paralleled on other freestanding shafts or crosses. On Face D there is a chequer-board pattern of the simplest kind, again making comparison difficult. More complex step patterns are found on the earlier groups of crosses, especially Kilree and Killamery (see p 137). The closest parallel is provided by Killamery A 15 iii where a simple chequer board pattern made up into cruciform shapes is further ornamented with relief spirals. Patterns of this type are not found amongst the 'Scripture' crosses but they have a new burst of popularity during the eleventh and twelfth centuries, particularly in metalworking, there being a good parallel on the Shrine of the Stowe missal dating to the second quarter of the eleventh century (Crawford, H.S. 1923, Fig. 2F; Raftery, J. 1941, 154). As Ellen Prendergast noted (1964, 13-14) step and chequer patterns are also found on some eleventh or twelfth century examples of stone carving, the 'Doorty' Cross, Kilfenora, Tuam cross and, in architectural ornament, on Cormac's Chapel, Cashel and the Romanesque doorway at Kilmore, Co Cavan.

The only ornament on Leggettsrath II is a boss at the centre of the crosshead on each broad face. This feature is common on the Irish crosses and therefore not very diagnostic. The only possible parallel may be made with the recently discovered Balsitru crosshead (National Museum, unpublished) one face of which is undecorated except for a small central boss.

Therefore, it is difficult to be sure whether Leggettsrath I and II

are part of the same monument. Due to the lack of ornament they are also almost impossible to date. On the strength of the parallels for the chequerboard pattern on Face D, Ellen Prendergast (*ibid*) suggested Leggettsrath I and II were also eleventh or twelfth century. This may be rather simplistic since chequer-board patterns were also common in the eighth and ninth centuries. In fact it seems possible that Leggettsrath I and II could have been produced at almost any point in the sequence of Irish freestanding crosses.

7) Templeneiry

Templeneiry is a rather remote site in the Glen of Aherlow (Map V). It has particular associations with St. Bernihert although the exact identity of this saint remains obscure and there are no references to Templeneiry in the early source material. Ó hEailidhe (1967, 104) has suggested various possibilities, the most likely being St. Berach, who had connections with Scotland and whose feast day, February 18th, is the same as that on which the local patten was held until recently.

Extensive archaeological remains have been recorded including seventy two pieces of sculpture (*op cit*). These consist mainly of sandstone slabs ornamented with simple relief crosses but there are also three larger pieces, two crossheads, Templeneiry I and III, and a cross-base, Templeneiry II.

a) Templeneiry I

This crosshead is Type Va, a variation of that on Clonmacnoise V (see p203) (Fig 39), though the wheel is solid and it does not have any roundels or rolls attached to it.

The ornamental scheme of Face A is unusual since there are figural panels on the cross arms and abstract decoration in the centre of the crosshead where one might have expected the Crucifixion as on the 'Scripture' and Barrow Valley crosses for example (see pp187, 204). Instead there is a cross of arcs ornamented with plaitwork with a six petal marigold in the centre. Crosses of arcs and marigolds are more common on simple cross slabs (Lionard 1960-1, 110-2) although there are examples of marigold ornament on Kilkieran II B 9 and Killamery C 2 (see pp109,142).

The three figural scenes are more enlightening although they seem to have been picked at random since they form no coherent group. A 3

would appear to represent the Arrest of Christ, an isolated scene from the Passion Cycle (see p 207; Fig 33). Another possible arrest is shown in a similar position on Castledermot South (Henry 1967, Pl. 65). The wrestling figures on A 4 are undoubtedly Jacob and the Angel which has parallels both amongst the 'Scripture' crosses and on Kilree D 3 and Killamery D 5 (see pp 233,149). A 5, however, is more difficult to identify since much of the detail has been lost. The Sacrifice of Isaac (see pp 121,231) seems most likely as the figure on the right is brandishing a sword-like object over the head of the second figure. However, the latter is not shown kneeling or bending over an altar as usually found in Irish representations. Nor is there an angel or ram. The Sacrifice of Isaac is shown in a similar position on Ullard A 4 and Castledermot North and South (op cit, Pls. 65, 71). Other possibilities are the Murder of Abel (see p 230) or the Massacre of the Innocents (see p 192). A panel on Castledermot South (op cit, Fig. 20: 1933, 144) is usually thought to show the latter. On the right is a standing figure shown face on. In his left hand is a round object (?shield) and in his right a raised sword. To his left is a smaller figure shown face on.

The ornament in the centre of the crosshead of Face C is similar to Face A; the crossarms are decorated with fragmentary interlace. There do not seem to be any parallels for decorating a crosshead in this way.

Overall Templeneiry I is difficult to place in the broader framework of Irish sculpture. The only clues to outside influence are provided by the figural iconography which suggests some knowledge of mainstream developments in Irish sculpture. The figural iconography, the use of which may be broadly compared with the 'Scripture' crosses and the Barrow Valley Group also provides the only good criterion for dating the cross-head. Any time during the second half of the ninth or the tenth centuries may be suggested although a later date is not impossible. The crosshead type would seem to support this view.

b) Templeneiry II

This cross-base is rather crude and entirely undecorated and is therefore difficult to discuss. It is possible that it could originally have been part of the same cross as Templeneiry I but this cannot be proved.

c) Templeneiry III

Little can be said about this crosshead as it seems rather crude. The crosshead type (VIII) has a skeuomorphic wheel. The plain central cross may be compared with crosses on cross-slabs from the same site (Ó hÉailidhe 1967, Figs. 2-7). In H.S.Crawford's first description of the monument (1907a, 208) he mentions 'the-head and shaft of a broken cross, about 4'6" high... the shaft has incised lattice and other patterns'. The shaft is not mentioned in Crawford's later article (1909a) and neither does anything catalogued by Ó hÉailidhe (1967) fit the description. Therefore the piece seems to have been lost between c 1907 and 1909 although one should make the point that, as Crawford does not actually illustrate the shaft, he may have been mistaken. If it existed the ornament described may have been similar to the cross-slab 2 (op cit, Fig. 2).

Dating a monument of this kind is almost impossible. One would imagine it might be broadly contemporary with the cross-slabs from the same site but as these are almost without decoration they are extremely difficult to date.

8) Thomastown

This cross is now situated (Map V) by an early thirteenth century church founded by Thomas Fitz Anthony (Killanin and Duignan 1967, 438). The site has no known earlier connections.

Little can be said about this fragmentary cross. The crosshead (Type VII) is the only possibly diagnostic feature. The emphasis is on the wheel rather than the actual cross form, a feature which may be compared with Clonmacnoise V (see p203). The position of the wheel arcs may be compared with Mona Incha II (Type VIb Fig. 39).

The only close parallel is another, more complete undecorated granite cross in Kildare churchyard (Crawford H.S. 1907a, 221). The shaft is tall and the crosshead, by comparison, small. This is in contrast with the early crosses (Chs. IV,V, VI) which have much larger crossheads.

Undecorated monuments are extremely difficult to date but because of the features noted the crosshead type may be late, perhaps some time during the eleventh or twelfth century.

9) Toureen Peakaun

Toureen Peakaun is a second site in the Glen of Aherlow situated not far from Templeneiry (Map V). It is associated with the hermit Beccan (Moloney 1962-5). Considerable archaeological remains survive including a church with inserted Romanesque windows, thirty grave slabs and several other examples of very crudely worked stone (Killanin and Duignan 1967, 133). A small excavation has been carried out on the site (Duignan 1944).

Amongst the sculpture is a shaft which has received considerable attention as it has a long inscription (Macalister 1949, 101; Duignan 1944; Moloney 1962-5, 99-101, Fig. 1; Killanin and Duignan 1967, 133; Harbison et al 1978, 57). The form of the shaft is unusual. The stone from which it is cut is more suitable for slabs than shafts which helps account for the slender depth of the monument. There are no projecting mouldings but rather the centre of the shaft projects on the Broad faces. The shaft has been broken away at the top and the original form of the monument and the purpose of the hole at the top of Face A are unclear. In the past it has been assumed to be a fragmentary freestanding cross. (Macalister 1949, 101; Duignan 1944; Killanin and Duignan 1967, 133) and Peter Harbison (et al 1978, 57) has gone on to claim 'that certain peculiarities in the details of the fragmentary Toureen Penkaun cross suggested that it was copied from an earlier cross in wood'. However I can see no evidence for this. He has also suggested (Letter May 1980) that a rectangular piece of stone with a tenon (H: 106 cm; W: 49 > 46 cm; D: 12 > 7 cm) standing nearby (Pl. 44.3) could be one of the cross arms which would have been affixed using a mortice and tenon joint forming a wheelless cross. However, the piece is very large compared with the size of the shaft and it seems unlikely that the two were ever part of the same monument.

The ornament, on the Broad faces only, consisting of incised crosses and simple incised step and interlace motives is not very diagnostic.

Various attempts have been made to read the inscription. Macalister (1949, 101) originally believed it to be in runes but in fact incised Hiberno-Saxon capitals have been used. Moloney (1962-5, 99-101) suggested the last two lines might read:

..... LAIS
DERNAD IN LIE

'so-and-so for whom this slab was made'.

This does seem possible but the actual forms of the letters are very difficult to make out and a rubbing of the inscription did not help. The only diagnostic feature is the actual type of lettering, Hiberno-Saxon capitals. As Leask said (Macalister 1949, 101) these may be compared with the Ardagh Chalice inscription (Organ 1973, Fig. 45); also with lettering in manuscripts, the Lindisfarne Gospels, the Book of Kells and the Book of MacDurnan (eg Nordenfalk 1977, Pl. 22; Henry 1974, f8R; Henry 1967, Pl. I). The only sculptural parallel is a mid eighth (?) century relief inscription on Tarbat X in Northern Pictland (Allen and Anderson 1903, III, Fig. 96). These comparisons suggest that the shaft could be eighth or ninth century.

CH. XI FOOTNOTES

1. This site has been very difficult to visit. Although Durrow I is a National Monument these two sculptural fragments are not in State Care. The land owners have been in dispute with the Board of Works over ownership of the monuments in State Care for some time and are therefore very unhelpful to enquiries made about Durrow II and III.
2. On Dysert O Dea the right arm is missing. The socket in the stone at this point suggests an arm was originally joined to the body using a mortice and tenon and the likelihood would seem to be that this was done to emphasize the gesture of the bishop, presumably benediction.
3. Perhaps it should also be noted that fine line interlace also appears at an early stage in the figural cross series on Kells South (Roe 1966, Pl. III).
4. In addition Ellen Prendergast (1964, 7) records a featureless dressed stone now placed next to I and II. It seems unlikely that this fragment is part of a cross and therefore it is not discussed here.
5. The nearest comparison would be the 'collared' shafts on crosses like Monasterboice West and Arboe (Macalister 1946, Pl. XII; Henry 1967, Pl. I).
6. The drawing of Leggettsrath II (Prendergast 1964, 6) does not appear very accurate.

Chapter XII. CONCLUSIONS

This study has concentrated on the larger pieces of sculpture, mainly shafts and freestanding crosses, from three Irish counties, Offaly, Kilkenny and Tipperary. It has sought to record the sculptural ornament on these monuments, to re-examine its significance in the light of earlier work and to look at various aspects, particularly the abstract decoration, which has received little attention in the past. It now remains to make some more general observations on the development of Irish sculpture during the Early Medieval Period.

It is likely that the dating of the majority of these monuments will always remain very difficult to assess. Little comparative material can be dated with any precision before the late eleventh century, the Lindisfarne Gospels (c 698-721) (Kendrick et al 1960) and the Book of Armagh (c 806) (Henry 1967, 100-1) being important exceptions. For this reason one is forced to rely upon the uncertainties of art historical comparison. One can never completely account for fashion leaders, regional backwardness, conservative craftsmen or objects handed down for several generations. Bearing in mind these problems, some discussion of the chronology, development and major influences on Irish Early Medieval sculpture ought, nevertheless, to be attempted.

It is likely that the freestanding stone cross is first seen in Ireland during the second half of the eighth century. There must have been indigenous influences at work, for example wood carving, earlier stone sculpture and Hiberno-Saxon metalworking motives but one can also trace the impact of developments further afield (see Ch. III). Indeed one suspects that the emergence of the freestanding cross in Northumbria, the Class II slab in Pictland and experiments with the wheelhead cross on Iona may well have encouraged Irish sculptors to turn their hands to similar projects. Continental and Mediterranean influences, for example the crux gemmata, must also have played their part.

During the late eighth and the first half of the ninth centuries there seem to have been several distinctive local groups of sculpture in

Ireland all concentrated on Offaly, Kilkenny and Tipperary and their detailed study has been a major objective of this work. Those concerned are the Clonmacnoise group, the Ossory crosses, Kilree and Killamery and other monuments from Tybroughney, Roscrea and Gallen Priory (Chs. IV-VIII, Ch. XI (5)). More precise dates are difficult to give except for Bealin, which may be dated to c 800 because of its inscription (see p88), but one suspects that each of the various groups may have been produced over a fairly short space of time, a period of intensive activity by a particular workshop. It is interesting to note that a variety of monument types are represented at this stage, not only the freestanding cross, but also shafts of various sizes and a single large slab, Gallen Priory I. The decorative emphasis is overwhelmingly abstract: interlace, spirals, frets, step patterns, zoomorphic and anthropomorphic motives, particular combinations being favoured by particular groups. Fantastic beasts, hunting scenes, processions and Scriptural iconography are found but they tend to play a subordinate role. At this time a distinctively sculptural repertoire of ornament is yet to evolve and the influences of other media are plain. The comparisons with manuscript illumination are particularly clear amongst the Clonmacnoise monuments; those with metalwork amongst the Ossory crosses. However, there are also important and previously little emphasized comparisons to be made with Pictish and Dalriadic sculpture. The cross types, the ornamental layout, the evolution of the boss, the fantastic beasts, the hunting scenes and the tentative use of figural iconography are all to be found on both sides of the Celtic Sea and testify to the important links between the Irish and Scottish churches in this period. Interestingly, parallels with Anglo-Saxon art are much more difficult to recognise. The influence of foreign models has also been suggested. Portable objects, for example ivories, manuscripts and textiles, would have entered Britain and Ireland as trade items, gifts or souvenirs from Gaul, Italy and the Mediterranean and during the first half of the ninth century Carolingian influences are also beginning to make their appearance. Links with Spain are far less tangible (Hillgarth 1961; 1961-2) but may emerge if the Visigothic material were made more accessible to detailed study and comparison.

The next major development may be seen in a number of 'Transitional' crosses which may be broadly dated to the mid to late ninth century. Kells South seems to hold the key to the entire group. The monastery of Kells rose to importance with the arrival of the monks from Iona in 806

and it is in this light that Kells as an artistic centre must be viewed. Kells South (Roe 1966, 10-25) displays a wide variety of influences: boss and spiral patterns reminiscent of Pictish sculpture (Stevenson 1955, 120-2), zoomorphic and anthropomorphic motives which also occur in Hiberno-Saxon manuscript designs but, most important, there is a new emphasis on figural, particularly Scriptural, ornament and here the influence of Carolingian iconography may first be evidenced. Kells South is crucial to the understanding of the development of Irish sculpture as it seems to spark off the entire 'Scripture' cross series (see p204) and it would undoubtedly benefit from a more detailed study in order to place it more precisely in its art historical context. To what extent it "influenced" monuments which appear stylistically earlier is more difficult to say but one would strongly suspect that the appearance of the Crucifixion and inhabited vine-scroll on Clonmacnoise IV (see pp72,86) and the Help of God iconography on Seir Kieran (see p121) is as a result of influences from Kells.

There are two groups of crosses studied in this thesis which may be regarded as 'Transitional'. The first, consisting of Kinnitty, Tihilly and Drumcullin (see Ch. VIII), is a local Midland group which makes considerable use of earlier abstract ornament designs found in the area but at the same time incorporates new ideas, in all likelihood emanating from Kells, in the form of the increased importance of figural iconography including the Carolingian Crucifixion type (see p180). The second group, centred on the Barrow Valley (see Ch. IX) is also decorated with a combination of Scriptural iconography and abstract ornament. The iconographical types are few and repetitive and would again seem to be derived from Kells.

The influence of metalwork and manuscript motives on these two groups of 'Transitional' sculpture seem negligible and, as one might expect by the mid ninth century (Henderson 1978), the influence of Pictish sculpture is equally weak. Instead the influences of indigenous sculpture are much more strongly felt, together with the increasing importance of Carolingian developments on the Continent.

The term 'Scripture' cross is used to refer to monuments where the change of emphasis from abstract ornament to figural iconography is complete. This group may be dated to the late ninth or early tenth centuries, perhaps with later developments continuing through the tenth century. These dates are supported by the inscriptions on Monasterboice

South and Clonmacnoise V (see p 246). In contrast to earlier monuments the majority of 'Scripture' crosses are found in Meath and the North (see Map IV), Clonmacnoise V and Durrow I being southern outliers (see Ch. X). In this period there seems to be much less influence on local groups of monuments but rather the adoption of a more national sculptural style. Scriptural iconography is dominant and the representations attempted are ambitious including, for example, a complex range of episodes from the David and Passion Cycles as well as scenes from the Old Testament and the Last Judgement. Precise parallels for these are surprisingly difficult to find but the Carolingian Empire is undoubtedly the most likely source. What abstract ornament remains is simple and repetitive, and stems from the long established motives on earlier sculpture.

The revival of the carving of freestanding stone crosses during the early twelfth century (see p 3) may be seen as the result of new influences from the Continent both in Church organisation (Hughes 1966, 253 ff) and in art. The influence of Viking ornament and Urnes style in particular is also adapted into the Irish sculptural repertoire for the first time. Two groups of crosses may be recognised, the limestone crosses from Aran and Clare (De Paor, L. 1955-6) and the Urnes style crosses from Co Tipperary (Farnes 1975; Raleigh 1975).

It has proved impossible to place some monuments within specific groups (Ch. XI) and the dating of some of these, chiefly because of the lack of decoration or crude execution, is likely to remain obscure. However, with the small cross from Dunnamaggan, one suspects the occasional use of the freestanding stone cross continued into the later Middle Ages.

Secondly, something should be said about the sculptural workshops. These freestanding crosses and shafts were undoubtedly made to adorn monasteries. For this reason one would expect the larger monasteries at least to have had their own stone masons' workshop and yard employing one or more craftsmen and apprentices. By far the most important of these from the archaeological evidence is Clonmacnoise where the day-to-day work of the sculptor is seen in the very large number of surviving grave-slabs and clearly it is in this type of milieu that experiment with more ambitious monumental pieces would have taken place. Indeed, Clonmacnoise is the only monastery from which a really long run of sculpture survives. The distinctive Clonmacnoise group (Ch. IV) would

seem to be amongst the earliest examples of the freestanding stone cross and shaft in Ireland. Clonmacnoise IV, although it is part of this group, shows close links with the Ossory crosses and Kells South. The 'Scripture' crosses are represented by Clonmacnoise V (Ch. X) and with Clonmacnoise VI (Ch. XI(1)) the sculptural tradition is carried right on into the Hiberno-Romanesque style. Therefore one can begin to glimpse the sculptural output of a monastery of international as well as national importance and it is likely that this output was also paralleled in metalworking and manuscript illumination although the archaeological evidence for this is lacking until the late eleventh or early twelfth centuries (Henry 1970, 49-50, 100ff).

The changes in the decoration of the Irish crosses may indicate a change in the way sculptural workshops were run. As had already been shown the earlier abstract crosses may be divided into distinctive local groups and it seems likely that each group represents a particular sculptural workshop. Here work could have been concentrated with craftsmen travelling to other monasteries in the area, possibly within the same paruchia as the need arose. However, with the adoption of the 'Scripture' cross iconography and with it a more national style it seems likely that some sculptors may have become more peripatetic, perhaps being trained in Kells or Armagh before being patronized by particular monasteries or commissioned to carry out specific jobs. Alternatively, sculptors could have been sent to Kells or Armagh to learn the latest fashions before returning to their own monastery.

Finally, this study is intended to be a small contribution towards a systematic and detailed corpus of Early Medieval Irish sculpture. To gather such a corpus would be a gigantic task but it seems essential if a proper record of this sculpture is to survive. Many of these pieces are situated in remote spots, often in ruined graveyards, where it is all too easy for them to be removed illegally or simply lost due to a dense coverage of vegetation. A great many pieces which were recorded in the nineteenth or early twentieth centuries no longer seem to be extant, for example the many grave slabs from Clonmacnoise which are recorded as lost by Macalister (1909, 41-50) and since his day still more have undoubtedly disappeared, although, without a new catalogue, the precise number is unknown. In other instances, although the sculpture survives, the carving seems less well preserved than in earlier photographs, for example Ahenny II (see p121), and it is clear that both the weather

and increased air pollution (Plenderleith 1968) are taking their toll. If a detailed record of the sculpture were compiled, it would act as valuable comparative material for Early Medieval sculpture elsewhere and objects in other media. It would also provide the essential background needed for the better protection, preservation and, one hopes, ultimately, the proper exhibition of the sculpture on its site of origin.

Equally, there is much left to be done in the study of other potentially related objects, for example Hiberno-Saxon metalwork and manuscripts. Detailed studies of metalwork, such as those for the Kells Crozier and the Moylough Belt Shrine (MacDermott 1955; O'Kelly 1964), where both the technical and art historical aspects are considered, and manuscripts such as the Lindisfarne Gospels (Kendrick et al 1960) are absolutely essential in our efforts to gain an overall view of the art of the period, how it was made, by whom and where. It is only when the more basic things have been studied that it will be possible to understand the broader developments in Hiberno-Saxon art.

APPENDIX IThe Circular Device in the Book of Mulling

On the lower half of the page of f94v of the Book of Mulling (T.C.D. 60 s VII/VIII) is a circular device which has frequently been interpreted as showing the plan of a monastery (see p39). This diagram was first studied by Lawlor (1894-5, 36ff; 1897, 167ff). A copy of his original transcription and translation is shown below.

Diagram (Fig. 36)

Diameter of outer circle: 4.2cm; diameter of inner circle 3.6cm.

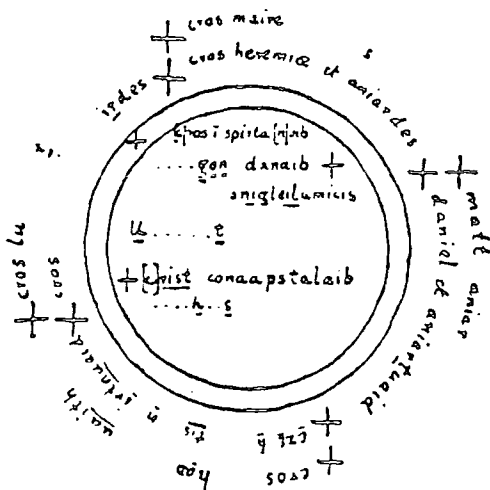
Transcription

Lawlor numbers the lines of writing for ease of reference. He also conjecturally supplies illegible letters 'where it seems certain that such letters existed'.

1. (Outer circle of writing). +cros mairc [ande]s +matt aniar
+cros [io]han [h]uairth +cros lu[c --]
[anoi]r
2. (Inner circle of writing). [ano]irdes+cros heremica et aniardes+daniel
et aniartuaid+eze [c]h[iel-]tis [--a]n[o]irthu-
aid+cros [esaiæ]

Taking next the lines within the circles in their order we have -

3. +[c]ros ī spirita [n]oib
4. ----gon danaib+
5. -----onigleilamicis
6. U----t.
7. +[c]rist conaapstalaib
8. ----h--s

l. 1. At the word [ande]s is a tear in the vellum, which the binders have remedied (?) by pasting a piece of paper over the word. It consists of about five letters and the tail of *f(s)* is distinct. In very good light the last five letters of [h]uaith are almost certain.

1. 2. There are five or six letters after "ezechiel," but "tis" is most uncertain, especially the two last letters; *t* may be *c*. See further below.

1. 5. *ni* may be *m* or *ri*; *ei* is possibly *u*; *l sec.* may be *b*; *ci* may be *a*.

Translation

1. +Cross of Mark South +Matthew West
+cross of John North +cross of Luke East
2. On the south-east+cross of Jeremiah, and on the south-west+Daniel, and on the north-west+Ezekiel [---], on the north-east+cross of [Isaiah].
3. +Cross of the Holy Spirit.
4. ----- with gifts+
5. ?
6. ?
7. +Christ with his apostles.
8. ?

Before attempting to decide the purpose of the diagram I recently re-examined the original (July 1981). The diagram is extremely faint and in some areas the lettering has completely vanished. On the whole what Lawlor recorded seems correct. However, even with the aid of a magnifying glass, and good daylight, the amount I could see was less. For this reason I record what was visible to me below. It does not make any difference to Lawlor's conclusions.

1. +Cros mairc ---
 matt aniar
+Cros -t-
+cr
2. +cros heremia et aniardes
+daniel et aniartuaid
+ ai
+cros
3. ī pirta
4. danaib+
5. jaingleib anuar
- 6.
7. ist onapstalaib
- 8.

APPENDIX 2Some Aspects of Hiberno-Saxon Metalwork1) Vernacular Style Metalwork; some problems and techniques

Various groups and techniques of Vernacular Style metalwork are mentioned in the text. For the sake of clarity some aspects should be discussed in a little more detail.

'Vernacular Style' was a term first coined by Mahr (1932, XXIV-V). He called it 'the Vernacular Keltic Style' and regarded it as lasting 'from the seventh century to the end of the eighth, i.e. to the first encounter with the Viking element, and carried on, with a distinct decline, until about 850'. Here the word 'Keltic' has been dropped in favour of Hiberno-Saxon. It could therefore originate from Ireland, Dalriada, Pictland or Northumbria and perhaps even from Wales or British workshops in other Anglo-Saxon Kingdoms. All that can be said about the chronology is that this style was developing during the sixth and seventh centuries, that it probably reached its zenith some time during the eighth and that in the course of the ninth century it gives way to the metalwork style which may be typified by Phase 1 of the Kells Crozier (MacDermott, 1955).

The main groups and techniques of Vernacular Style metalwork are listed below. The list is by no means exhaustive; it is merely intended to illustrate the comparisons made with the sculpture in the main text. It is impossible to date any of these groups or techniques with any degree of precision or to ascribe them to particular workshops or even countries. Nor are the techniques mutually exclusive. Indeed many objects, especially the more elaborate such as the Ardagh chalice, use a variety of different techniques.

a) The 'Engraved Group'

This technique, which is easy to recognise as it is seldom found combined with others, is found on a number of objects, mainly small wooden pails overlaid with sheet bronze. This has been delicately engraved with fine-line patterns giving the impression of drawing. Objects in this group may be exemplified by the Birka Pail (probably a trade item from the Swedish port of Birka), the Hopperstad and Farnen pails, the Torshov fragment and the Vinjum object, all found in Norway, the Copenhagen shrine found in Denmark, the Stromness Mount found in Orkney and the Domnach Airgid which is probably Irish (Mahr 1932, Pl. 30; Raftery 1940, Pls. 103,

117, Henry 1965, Pl. 87; Petersen 1940, Fig. 93; Bruce-Mitford 1960, 250). Egil Bakka (1963, 32) has suggested they were made in Northumbria because of their use of inhabited vine-scroll. However, in view of their findspots, all that can be said is that they belong to a Hiberno-Saxon milieu.

b) Objects cast in high plastic relief: (Henry 1965, 106).

The most common motives employed are serpents, dragons, displayed beasts, bosses and fake chip-carving. The group includes the St. Germain and Gausel plaques (Mahr 1932, Pls. 25, 26; Bakka 1965, 39-40, Pl. 4b), the Romfohjellen, Meløy, Halsan, Vatne, Lilleby and Copenhagen mounts (Petersen 1940, Figs. 67, 86, 76, 46, 11; Wilson 1955), the Steeple Bumpstead boss and one face of the Ekerö crozier (Henry 1965, Pl. 43; Holmquist 1955).

c) Objects decorated with panels of champlevé enamel and millefiori glass set in high relief castings: (Henry 1965, 104).

This is the characteristic ornament on many metalwork mounts used to decorate bronze bowls and wooden buckets, among them examples from Oseberg, Myklebostad, Hopperstad and Clonmacnoise (Petersen 1940, Figs. 94, 108, 109; Henry 1965, Pl. 29). Such decoration is also combined with other techniques on the Ekerö crozier, the Copenhagen shrine and the Moylough belt shrine (Petersen 1940, Fig. 89; O'Kelly 1964).

In addition to these distinctive groups there are a great many small or fragmentary pieces of metalwork, mounts, brooches, etc. which may be described as Vernacular Style but which do not seem to belong to any particular group. There are also objects where the techniques employed seem to be unique such as the inlaid ornament on the Emly shrine (Swarzenski 1954) (see p 79), the openwork effect on the St. Germain plaques (Mahr 1932, Pls. 25, 26) and the stamped mounts on the Moylough belt shrine (O'Kelly 1964, 172). In addition there are also several pieces of luxury metalwork which make use of many techniques. The Ardagh Chalice (Organ 1973) is the most obvious example which combines cast chip-carving, delicate filigree and engraved work with inlaid glass shapes and high relief glass studs. The paten, paten stand and chalice from the Derrynavlan hoard make use of a similar although not identical range of techniques (O Riordáin, B 1980a, 1980b; Ryan, M. 1980). Some of the ornate penannular brooches also fall into this category, for example the Tara, Dunbeath and Hunterston brooches (Henry 1965, 108-111, Pls. 38,

40, 41, 42; Allen and Anderson 1903, I, XCIV; Stevenson 1974).

2) The Impact of the Vikings on Irish metalworking

Françoise Henry (1975, 61; 1967, 17) has put forward the view that the advent of the Vikings in Ireland c 800 brought an immediate end to the production of Vernacular Style metalwork. Furthermore, the deposition of many Vernacular Style objects in Norwegian graves (Petersen 1940) has underlined the belief that the Irish monasteries were early devastated by Viking raiders even though it is impossible to date these finds with any degree of accuracy or to be sure that they come from Ireland (Graham-Campbell 1978-9). This view is however misleading and the reasons why have recently been ably summarised by James Graham-Campbell (ibid), the most important being that the Viking raids were not really a serious factor until their dramatic escalation during the 830s (Hughes 1968, 24-7). However, James Graham-Campbell does seem to have underplayed the possible effects of the Norse on metalwork production during the mid ninth century, the period of the worst raids and early settlement. While one must acknowledge that ornamental metalworking continued on a limited scale with the aid of the new influx of silver, and indeed James Graham-Campbell's work (1972; 1973-4; 1975) testifies to this, one should not under-estimate the destruction of the Viking raids. As Kathleen Hughes (1968, 27) has said one cannot ignore entirely either the contemporary annalistic accounts of the destruction or the Hiberno-Saxon metalwork found in the Norse homelands.

Allied to this is the problem of when and to what extent Viking art styles began to influence Irish craftsmen. In England Viking influence can be seen in the early stages of the Danish settlement at York where Jellinge style sculptural fragments have been found at Newgate and Coppergate (Bailey 1980, 55-6, Pls. 11, 12) which could date to as early as the last quarter of the ninth century. In Ireland such influence is first detectable at a much later date. The earliest influences which can definitely be recognised are a single example of Jellinge on the Inisfallen Crozier and a group of objects, consisting of the Clonmacnoise crozier, phase II of the Kells crozier, the cumdach of the Cathach, the cumdach of the Misach and the Glankeen bell shrine, which display developed Ringerike style elements. All these are probably datable to the second half of the eleventh century (Wilson and Klindt-Jensen 1966, 143-6; Henry 1971, 83-94, 198). Viking influence can be traced at a similarly late date on manuscripts

(op cit, 53ff) and sculpture where there are Ringerike elements on some of the late crosses from Aran and Clare (De Paor, L. 1955-6, 69-70) and Urnes is the characteristic ornament of the crosses at Cashel, Mona Incha II and Roscrea II (see p 3).

So, why this dichotomy in the adoption of Viking art motives between England and Ireland? The answer must surely lie in the nature of the settlement. The Vikings settled the whole of North Eastern England whereas in Ireland their occupation was confined to coastal urban centres, the most important of which was Dublin. The Viking foothold on Ireland was not secure until after their return to Dublin in 917 (they had been expelled in 902) and it was not until the Irish victory at the Battle of Tara in 982 that the Vikings were finally forced to drop their hopes of conquest in favour of more peaceful trading with their Irish neighbours (Dolley 1966, Ch. 2). Therefore it is not until the eleventh century that the environment seems right for the exchange of artistic ideas between Norse craftsmen and their Irish counterparts.

APPENDIX 3.Comparisons between the abstract ornament on Clonmacnoise I-IV, Banagher and Bealin and that on the Clonmacnoise grave-slabs.

Three hundred or more grave-slabs from Clonmacnoise have been recorded by Petrie (1872) and Macalister (1909), the greatest number from any single site in Ireland. It is interesting to note that although the repertoire of ornament on these slabs is almost exclusively abstract, it is entirely different to that used on the shafts and crosses of the Clonmacnoise group (Ch. IV). Obviously many of the grave-slabs are later in date, displaying the characteristic expansional cross of the tenth and eleventh centuries but, as Pádraig Lionard (1960-1, 144-6) has pointed out, there is an almost total lack of zoomorphic ornament on any of the monuments and he goes on to suggest that this may be because such patterns called for more than 'routine skill' on the part of the sculptors. Indeed the patterns employed are simple, often repetitive frets, interlace and spirals and the ornament appears inward looking and little dependent upon the influence of other media. In the Anglian sphere Collingwood (1927, 16) has alluded to a similar difference of style between the flat grave-slabs and the three dimensional sculpture. This dichotomy is puzzling as it would tend to imply that the artisans who carved the grave-slabs were not necessarily the same men who carved the crosses but the answer perhaps lies in the scale of work being undertaken. The grave-slabs were mass-produced, probably in wood as well as in stone, with the purpose of indicating graves, whereas the shafts and crosses must have been conceived as long term projects to the Glory of God and illustrative of the monastery's wealth and prestige. A parallel may perhaps be suggested in the difference between the sparsely decorated pocket Gospels, such as the Book of Dimma (Dublin TCD, MS 59) and the luxurious altar manuscripts exemplified by the Book of Kells.

APPENDIX 4The Texts of Irish Prayers for Deliverance1) Féilire ÓengussoThe Martyrology of Oengus

- | | |
|---|---|
| <p>line 437. Anim cech maicc bethad
is triut ro m'ebad,
síil n'Adaim as díxu
la hÍssu ro sóerad.</p> | <p>The soul of every son of Life
through Thee has been sanctified:
Adam's race that is highest
by Jesus has been saved.</p> |
| <p>441. Rom-sóerae, á Íssu,
mo chorp agus m'anmain
ar cech ulc dochuissin,
frisoirg forsin talmain.</p> | <p>Mayst Thou save me, O Jesus,
my body and my soul, from
every evil that exists, that
offends on the earth.</p> |
| <p>445. Rom-sóerae, á Íssu,
á Choimmdiu cáin comul,
amail sóersai Héili
la hÉnóc don domun.</p> | <p>Mayst Thou save me, O
Jesus, O Lord of fair assemblies,
as Thou savest Elijah, with
Enoch from the world.</p> |
| <p>449. Rom-sóerae, á Íssu,
ar cech ulc for íre
amail sóersai Nóe
macc Lamech din díle.</p> | <p>Mayst Thou save me, O
Jesus, from every ill on earth,
as Thou savest Noah son of
Lamech from the Flood.</p> |
| <p>453. Rom-sóerae, á Íssu,
á rí glésse glandae,
amail sóersai Abram
de lámaib na Caldae.</p> | <p>Mayst Thou save me, O Jesus,
O King of pure brightness, as
Thou savedst Abram from the
hands of the Chaldeans.</p> |
| <p>457. Rom-sóerae, á Íssu,
á rí rúndai rathmar,
amail sóersai Loth
de pheccad na cathrach.</p> | <p>Mayst Thou save me, O
Jesus, O King mysterious,
gracious! as Thou savedst Lot
from the sin of the cities.</p> |
| <p>461. Rom-sóerae, á Íssu,
á rí úasail amri,
amail sóersai Iónas
de brú cėti magni.</p> | <p>Mayst Thou save me, O
Jesus, O King noble, wondrous!
as Thou savedst Jonas from
the belly <u>ceti magni</u>.</p> |

- line 465. Rom-sórae, á Íssu, Mayst Thou save me, O Jesus,
it riched ilrathach, into Thy many-graced heaven,
amail soersai Isac as Thou savedst Isaac
de lámaib a athar. from his father's hands.
469. Rom-sóerae, á Íssu, Mayst Thou save me, O Jesus,
lat noebu tan tíastae, with Thy saints when they come,
amail sóersai Teclam as Thou savedst Thecla
de ginol na bíastae. from the maw of the monster.
473. Rom-sóerae, á Íssu, Mayst Thou save me, O Jesus,
ro éra do máthre, whom Thy Mother's folk rejected,
amail sóersai Iacób as thou savedst Jacob
de lámaib a bráthre. from the hands of his brethren.
477. Rom-sóerae, á Íssu, Mayst Thou save me, O Jesus,
ar cech nolc nád rachrad from every ill that is not....
amail sóersai Ióain as Thou savedst John
de neim inna nathrach. from the poison of the serpent.
481. Rom-sóerae, á Íssu, Mayst Thou save me, O Jesus,
ar iffern co tróigi, from hell with misery,
amail sóersai Dauid as Thou savedst David from the valour
de gail claidib Góli. of Goliath's sword.
485. Rom-sóerae á Íssu, Mayst Thou save me, O Jesus;
ro sóerais na huili, Thou hast saved all
Susannam co nordun (as Thou savedst) the noble Susannah
iarsind forgul fuirri. after the lie concerning her.
489. Rom-sóerae, á Íssu, Mayst Thou save me, O Jesus,
ar écnairc do báge, for the sake of Thy conflict,
amail sóersai Ninuén as Thou savedst Nineveh
i n aimsir na pláge. in the time of the plague.
493. Rom-sóerae, á Íssu, Mayst Thou save me, O Jesus
glé lim atom-didmae, I am clear that Thou wilt acknowledge me,
amail sóersai popul as Thou savedst the people of Israel
Israel de Gilbae from (Mount) Gilboa.

- Line 497. Rom-sóerae á Íssu,
a Choimmdiu as deodam,
amail sóersai Daniél
assin chuithi leoman.
Mayst Thou save me, O Jesus,
O Lord who are divinest,
as Thou savedst Daniel
out of the den of lions.
501. Rom-sóerae, á Íssu,
a rí sochlai sóbis,
amal sóersai Moiséen
de manu Farónis.
Mayst Thou save me, O Jesus,
O King famous, gentle!
as Thou savedst Moses
de manu Pharaonis.
505. Rom-sóerae, á Íssu,
mórferta dorignis,
amail sóersai maccu
de camíno ignis
Mayst Thou save me, O Jesus,
who has wrought great miracles,
as Thou savedst (the Three) Children
de camíno ignis.
509. Rom-sóerae, á Íssu,
a rí cecha clainde,
amail soersa Tóbe
de thróge na daille.
Mayst Thou save me, O Jesus,
O King of every clan,
as Thou savedst Tobit
from the misery of blindness.
513. Rom-sóerae, á Íssu,
ar écnairc do martrae,
Pól Petar fiad rígaib,
de dígail na carcrae.
Mayst Thou save me, O Jesus,
for the sake of Thy martyrs,
(as Thou savedst) Paul (and) Peter
before the kings
from the punishment of the prison.
517. Rom-sóerae, á Íssu,
ar accais cech thedmae,
amal sóersai Iób
de fochidib demnae.
Mayst Thou save me, O Jesus,
from the cause of every disease,
as Thou savedst Job
from the devils' tribulations.
521. Rom-sóerae, á Íssu,
á Chríst, ní rop áilsed,
amail sóersai Dauid
ar Sauul dia tháinsem.
Mayst Thou save me, O Jesus,
O Christ, let there not be neglect:
as Thou savedst David from Saul,
from his accusation.
525. Rom-sóerae, á Íssu,
ar écnairc do máthre,
amal sóersai Ióséph
de lámaib a bráthre.
Mayst Thou save me, O Jesus
for the sake of Thy mother's folk,
as Thou savedst Joseph
from the hands of his brethren.

- Line 529. Rom-sóerae, á Íssu, Mayst Thou save me, O Jesus,
 á rí benedicte, O blessed King
 Israél co noíbi (as Thou savedst) holy Israel
 de dóiri Éigte. from the bondage of Egypt.
533. Rom-sóerae, á Íssu, Mayst Thou save me, O Jesus,
 ol is frit mo chairde, for with Thee is my compact,
 amail sóersai Petar as Thou savedst Peter
 de thonnaib na fairge. from the waves of the sea.
537. Rom-sóerae, á Íssu, Mayst Thou save me, O Jesus,
 ar iffearn ngér ngenech, from keen, gaping (?) hell,
 amail sóersai Ióain as Thou savedst John
 assin dabaig thened. out of the fiery vat.
541. Rom-sóerae, á Íssu, Mayst Thou save me, O Jesus,
 á rí úas na flathib, O King above the princes!
 amail sóersai Samsón as Thou savedst Samson,
 térnae assin chathir. who escaped out of the city.
545. Rom-sóerae, á Íssu, Mayst Thou save me, O Jesus,
 m'anmain ar cech ndígail, my soul from every punishment,
 amail sóersai Mártain as Thou savedst Martin
 ar sacart ind ídaill. From the priest of the idol.
549. Rom-sóerae, á Íssu, Mayst Thou save me, O Jesus,
 ar écnairc do theglaig, for the sake of thy household,
 amail sóersai Pátric as Thou savedst Patrick
 de thonnud hí Temraig. from death by poison in Tara.
553. Rom-sóerae, á Íssu, Mayst Thou save me, O Jesus,
 ol is duit am céle, for I am a servant of Thine,
 amal sóersai Cōemgein as Thou savedst Cōemgein
 de chutaim in tslébe. from the falling of the mountain.
557. Rom-sóerae, á Íssu, Mayst Thou save me, O Jesus,
 it bithbúana t'ferta, everlasting are Thy miracles!
 á Chommdiu non-áiliu, O Lord whom I entreat,
 frisáiliur do thechta. I expect Thy messengers.

Line 561. Tan domm -í techt irguis, When the great boon may come to me,
 cid i caise nó chorgus, whether at Easter or in Lent,
 rom=snádat i pardus may the kingfolk I have commemorated
 ind rígrad imrordus. convoy me into paradise!

565. Imrordus in rígraid I have commemorated the kingfolk
 immon ríg úas nélaib, around the King above the clouds,
 etc. etc.

(Stokes, W.1915)

2) Hymnus S. Colmani Mic Ui Cluasaigh

Sén Dé donfe fordonte, God's blessing bear us, succour us!
 macc Maire ronfeladar May Mary's son protect us!
 for a oessam dún innocht, Under His protection may we be tonight!
 cia tiasam cain=temadar. Withersoever we go, may He well protect!
 Itir foss no utmaille, In rest or in activity,
 itir suide no sessam, Seated or standing,
 ruire nime fri cech tress, Heaven's King, against every battle;
 iss-ed attach adessam. This is the supplication we shall make.

Itge Abeil meic Adaim, A supplication of Abel, Adam's son,
 Heli, Enoc, di-ar cobair, Of Eli, of Enoch, for our help!
 ronsoerat ar dian-galar, May they save us from swift disease,
 secip leth fon mbith fogair. Wherever throughout the world it threatens!

Noe ocus Abraham, Noah and Abraham,
 Isac in macc adamra, Isaac the wondrous son,
 immuntisat ar tedmáim, May they come round us against pestilence,
 nachantairle adamma. Neither let famine visit us!

Ailme athair tri cethrur We beseech the father of the twelve,
 ocus Ioseph a nu-uas(er), And Joseph their younger [brother],
 ronsóerat a n-ernaighthi May their prayers save us
 co rig n-il-ainglech n-uasal. To a King of many angels, noble!

Snaidsium Moisi deg-tuisech May Moses good leader, protect me,
 ronsnaid tria rubrum mare, Who protected through Rubrum Mare;
 Iesu, Aaron macc Amra, Joshua, Aaron son of Amra,
 Daid in gilla dána. David the daring youth!

Iob cosna fochaidib
 sech na nemi ronsnada,
 fáthí Fiadat ronanset
 la secht maccu Mocaba.

Eoin baptaist adsluinnem,
 rop dithiu dún, rop snadud,

Iesu co n[-a] apstalaib
 rop di-ar cobair fri gabud.

Maire Ioseph donringrat
 et spiritus Stefani,
 as cach ing donforslaice
 taithmet anma Ignati.

Cech martir, cech dithrubach,
 cech noeb robai hi ngenmmai,
 rop sciath dún di-ar n-im-degail
 rop saiget huan fri demmai.

Regem regum rogamus
 in nostris sermonibus
 anacht Noe a luchtlach
 diluui temporibus.

Melchisedech rex Salem
 incerto de semine,
 ronsoerat a airnighthe
 ab omni formidine.

Soter soeras Loth di thein,
 qui per saecula habetur,
 ut nos omnes precamur
 liberare dignetur.

Abram de Ur na Galdai,
 snaidsiunn ruri ronsnada,
 soersum soeras in popul
 limpa fontis i nGaba.

Job with the tribulations,
 May he protect us past the poisons;
 May God's prophets guard us,
 With Machabaeus' seven sons!

John Baptist we invoke,
 May he be a shelter to us, be a
 protection;

Jesus with his apostles
 Be for our help against danger!

May Mary, Joseph watch over us,
Et spiritus Stephani,
 From every strait release us
 Remembrance of Ignatius' name!

Every martyr, every hermit,
 Every saint who lived in chastity,
 Be a shield to us for our defence,
 Be an arrow (sent) from us against
 demons!

Regem regum rogamus
In nostris semonibus,
 Who saved Noah [and] his crew
Diluui temporibus.

Melchisedec rex Salem
Incerto de semine,
 May his prayers free us
Ab omni formidine!

The Saviour who saved Lot from fire
Qui per saecula habetur,
Ut nos omnes precamur
Liberare dignetur.

Abraham of Ur of the Chaldees,
 May the King protect us, may He protect
 us!
 May he free me, He who freed the people
Lumpha fontis in Gaba!

Ruri anacht tri maccu
a surann tened co ruadi,
ronnain amal roanacht
Dauid de manu Gólai.

The King, who saved three children
From a furnace of fire with redness,
May He save us, as He saved
David de manu Goliath.

Flaithem nime locharnaig
ardonroigse di-ar trógi
nat leic suum profetam
ulli leonum ori.

May the ruler of lamp-lit heaven
Have mercy on us, for our wretchedness!
He who left not suum profetam
Ulli leonum ori.

Amal foedes in aingel
tarslaic Petrum a slabreid
doroiter dún di-ar fortacht
rop reid remunn cech n-amreid.

As He sent the angel
Who loosened Peter from his fetter,
May he be sent to us for our assistance,
May every rough thing be made smooth
before us!

Di-ar Fiadat rontolomar
nostro opere digno,
robem occa i mbi-bethaid
in paradisi regno.

To our God may we render ourselves
pleasing,
Nostro opere digno,
May we be in eternal life
In paradisi regno.

Amal soeras Ionas faith
a brú míl moir, monar ngle,
snaidsiunn deg-ri tomtach trén
sén Dé donfe fordonte.
contd.

As He freed Jonas prophet
From the whale's belly, bright deed,
May the good King, threatening, mighty,
protect us!
God's blessing bear us, come upon us!
contd.
(Bernard and Atkinson 1898, I, 26-9; II,
14-5).

3) The Stowe Missal (RIA Ms. D.II.3)
Ordo Missae, preface:

Peccauius domine Peccauius páce peccatis nostris et
salua nos qui gubernasti noe super undas dilui exaudi
nos et ionan diabiso uerbo reuocasti libera nos qui petro
mergenti manum porrexiisti auxiliare nobis christe fili dei.

'We have sinned Lord, we have sinned. Pardon us from our sins
and save us, you who steered Noah over the waves of the flood
listen to us, and you who with a word called back Jonah from the
abyss free us, you who stretched out your hand to Peter as he
was sinking, save us Christ son of God'. (Warren. 1915, f12)

BIBLIOGRAPHYAbbreviationsa) Journals

JRSAI Journal of the Royal Society of Antiquaries of Ireland.

PRIA Proceedings of the Royal Irish Academy

PSAS Proceedings of the Society of Antiquaries of Scotland.

Other journals, cited less frequently, are quoted according to the Council for British Archaeology conventions.

b) Annalistic Sources

It is unusual to refer to these under the name of the editor and the page number; an abbreviated form of the name of the annals and the year concerned is much more common. This convention has been used.

A Clon = Murphy, D 1896

AFM = O'Donovan 1851

A Tig = Stokes, W 1895-7

AU = Hennessy and MacCarthy 1887-1901

CS = Hennessy 1886

c) Other

N.D. = No date of publication given.

Bibliography

- Åberg, N. 1943 The Occident and the Orient in the Art of the seventh century, I, The British Isles, Kungl. Vitterhets Historie och Antikvitets Akademiens Handlingar 56:1.
- Åberg, N. 1945 The Occident and the Orient in the Art of the seventh century, II, Lombard Italy, Kungl. Vitterhets Historie och Antikvitets Akademiens Handlingar 56:2.
- Åberg, N. 1947 The Occident and the Orient in the Art of the seventh century, III, The Merovingian Empire, Kungl. Vitterhets och Antikvitets Akademiens Handlingar 56:3.
- Adcock, G. 1974 A Study of the Types of Interlace on Northumbrian Sculpture. M. Phil. Thesis, Durham, unpublished.
- Adcock, G. 1978 The Theory of Interlace and Interlace Types in Anglian Sculpture in Lang 1978, 33-46.
- Allen, J R. 1885 Christian Symbolism in Great Britain and Ireland. London.
- Allen, J R. 1896-7 On Some Points of resemblance between the art of the early sculptured stones of Scotland and Ireland, PSAS, 31, 309-332.
- Allen, J R. 1900-1 The Early Christian Monuments of Iona; with some suggestions for their better preservation. PSAS, 35, 79-93.
- Allen, J R. 1904 Celtic art in Pagan and Christian times. London.
- Allen, J R and Anderson, J. 1903 The Early Christian Monuments of Scotland. Edinburgh, 3 parts.
- Anderson A O and M O (eds) 1961 Adomnan's Life of Columba. Edinburgh.
- Anderson, J. 1910 The architecturally-shaped shrine and other reliquaries of the early Celtic church in Scotland and Ireland, PSAS, 44, 259-81.
- Anderson, M D. 1935 The Medieval Carver, Cambridge.
- Andrews, F B. 1925 The Medieval Builder and his methods. Oxford.
- Archdall, 1786 Monasticon Hibernicum. Dublin.
- Armstrong, E C R. 1908a An account of some Early Christian monuments discovered at Gallen Priory, JRSAL, 38, 61-6.
- Armstrong, E C R. 1908b A cross-slab and fragment from Gallen Priory, JRSAL, 38, 390-3.
- Bailey R N. 1963 The Clogher Crucifixion, JRSAL, 93, 187-8.

- Bailey, R N 1974 The Sculpture of Cumberland, Westmoreland and Lancashire North-of-the-Sands in the Viking period. Ph.D. Thesis, Durham, unpublished.
- Bailey, R N 1977 The meaning of the Viking age shaft at Dacre, Trans. Cumberland and Westmoreland Antiq. and Archaeol. Soc., 77, 61-74.
- Bailey, R N 1978a The chronology of Viking-Age sculpture in Northumbria in Lang 1978, 173-204.
- Bailey, R N 1978b The Durham Cassiodorus, Jarrow Lecture 1978, Jarrow.
- Bailey, R N 1980 Viking Age Sculpture in Northern England. London.
- Bain, G 1951 Celtic Art, the methods of construction. London.
- Baines, A 1957 Woodwind instruments and their history. London.
- Bakka, E 1963 Some English decorated metal objects found in Norwegian graves, Årbok for Universitet i Bergen Humanistisk Serie, 1.
- Bakka, E 1965 Some decorated Anglo-Saxon and Irish metalwork found in Norwegian Viking graves in Small, A (ed), Fourth Viking Congress. London.
- Baldwin-Smith, E 1918 Early Christian Iconography and the School of Provence, Princeton Monographs in Art and Archaeology, 6.
- Baltrusaitis, J 1929 Études sur l'art médiéval en Géorgie et en Arménie. Paris.
- Bateson, J D 1973 Roman material from Ireland: a reconsideration, PRIA, 73c, 21-98.
- Battiscombe, C F(ed) 1956 The Relics of St Cuthbert. Oxford.
- Baum, J 1937 La Sculpture figurale en Europe à l'époque Mérovingienne. Paris.
- Becker, A 1973 Franks Casket. Regensburg.
- Beckwith, J 1960 Some Anglo-Saxon carvings in ivory, The Connoisseur, 146, 241-6.
- Beckwith, J 1961 The art of Constantinople, an introduction to Byzantine art. London.
- Beckwith, J 1963 Coptic Sculpture. London.
- Beckwith, J 1969 Early Medieval Art, revised edition, London.
- Beckwith, J 1972 Ivory carvings in Early Medieval England. London.
- Beckwith, J 1979 Early Christian and Byzantine Art, 2nd edition, London.

- Berefelt, G 1968 A study on the winged Angel, the origin of a motif, Acta Universitatis Stockholmiensis, 14.
- Bernard, J H and 1898 The Irish Liber Hymorum, Henry Bradshaw Society,
Atkinson, R (eds) 13 and 14.
- Bieler, L 1948 Review of 'Masai , F, Essai sur les origines de la miniature dite irlandaise', Speculum, 23, 495-502.
- Bieler, L 1963 Ireland, Harbinger of the Middle Ages, London.
- Bieler, L 1976 Ireland's contribution to the culture of Northumbria in Bonner, G (ed), Famulus Christi, London, 210-228.
- Bigger, F J 1908 The ancient cross of Drumgolan in the Co. Down, UJA, 2 ser, 14, 56-8.
- Bigger F J and 1897a Ardboe Co. Tyrone: its cross and churches, UJA, 2 ser,
Fennell, W J 4, 1-7.
- Bigger, F J and 1897b The high cross of Drumpatrick, UJA, 2 ser, 4,
Fennell, W J 272-4.
- Binchy, D A 1975 The passing of the old order in O'Cuiv, B, 119-132.
- Blackett, W R 1851 Monumental crosses at Kilkieran, JRSAI, 2, 487-8.
- Blindheim, C 1976 A collection of Celtic (?) bronze objects found at Kaupang (Skiringssal), Vestfold, Norway in Almqvist, B and Green, D (eds), Seventh Viking Congress, 1973, Dublin, Dundalk, 10-27.
- Bober, H 1967 On the illumination of the Glazier Codex in Lehmann, H H, (ed), Homage to a Bookman: Essays for H P Kraus. Berlin, 31-49.
- Bøe, J 1940 Norse Antiquities in Ireland, part 3 of Shetelig, H (ed) Viking Antiquities in Great Britain and Ireland. Oslo.
- Boinet, A 1913 La Miniature Carolingienne. Paris.
- Bonser, W 1957 An Anglo-Saxon and Celtic Bibliography (450-1087). Oxford. 2 vols.
- Boswell, C S 1908 An Irish precursor of Dante. Long Acre.
- Brehaut, E 1964 An Encyclopedist of the Dark Ages, Isidore of Seville, New York. (Reprint of 1912 edition).
- Brønsted, J 1924 Early English Ornament, trans. Major, A.J. London, Copenhagen.
- Brophy, E F 1967 Three Carlow monasteries, Carloviana, 1, No. 16,
- Brown, G B 1915 The Arts in Early England, 3, Saxon art and industry of the Pagan period. London.

- Brown, G B 1921 The Arts in Early England, 5, The Ruthwell and Bewcastle crosses, the Gospels of Lindisfarne and other Christian monuments of Northumbria. London.
- Brown, T J 1971 Northumbria and the Book of Kells, Jarrow Lecture, Jarrow.
- Browne, G F 1887 On basketwork figures of men represented on sculptured stones, Archaeologia, 50, 287-94.
- Bruce-Mitford, R L S 1960a The Methods of Construction of Insular ornament in Kendrick et al 1960, I, 221-231.
- Bruce-Mitford, R L S 1960b The Lindisfarne Style of metalwork in Kendrick et al 1960, I, 250-8.
- Bruce-Mitford, R L S 1972 The Sutton Hoo Ship Burial: a handbook. 2nd ed. London.
- Bruce-Mitford, R L S and M 1970 The Sutton Hoo Lyre, Beowulf, and the origins of the frame harp, Antiquity, 44, 7-13.
- Buick, G R 1903, The high cross of Connor, Co Antrim, UJA 2 ser, 9, 41-2.
- Byrne, F J 1967, Seventh Century documents, Ir Ecclesiastical J, 5 ser, 108, 164-82.
- Caubrol, F and Leclercq, H 1907-53 Dictionnaire d'Archéologie Chrétienne et de Liturgie. 15 vols. Paris.
- Calvert, J 1977 The Crosses of County Donegal: problems of Irish art in the eighth and tenth centuries, from unpublished work for Ph D Thesis on The connections between Irish, English and Scottish sculpture. Santa Clara.
- Carmody, F J 1941 Physiologus Latinus Versio Y, University of California Publications in Classical Philology, 12 (7), 95-134.
- Carney, J (ed. and trans.) 1964 The Poems of Blathmac son of Cú Bretlan together with the Irish Gospel of Thomas and a poem on the Virgin Mary. Dublin.
- Carrigan, W 1905 The History and Antiquities of the Diocese of Ossory. 4 vols. Dublin.
- Carroll, F M 1895 Some notes on the Abbey and cross of Moone and other places in the valley of the Griese, J Kildare Archaeol Soc, 1, 286-94.
- Casson, S 1932 Byzantium and Anglo-Saxon Sculpture, Burlington Mag, 61, 265-74.

- Casson, S 1933 Byzantium and Anglo-Saxon Sculpture, Burlington Mag, 62, 26-36.
- Chadwick, N K 1961 The Age of the Saints in the Early Celtic Church. Riddell Memorial Lectures 1960. London.
- Chadwick, N K 1975 The Vikings and the Western World in O'Cuiv 1975, 13-42.
- Champneys, A C 1910 Irish Ecclesiastical Architecture. London.
- Chart, D A (ed) 1940 A Preliminary Survey of the Ancient Monuments of Northern Ireland, conducted by the Ancient Monuments Advisory Council for Northern Ireland. Belfast.
- Clapham, A W 1933 Review of 'Henry, F, La Sculpture Irlandaise', Antiq J. 13, 477.
- Clapham, A W 1934 Notes on the origins of Hiberno-Saxon art, Antiquity, 8, 43-62.
- Clark, J 1903 Kilree Church and round tower, Co Kilkenny, JRSAI, 33, 213-6.
- Coatsworth, E 1974 Two examples of the Crucifixion from Hexham in Kirby 1974, 180-4.
- Coatsworth, E 1979 The Iconography of the Crucifixion in Pre-Conquest Sculpture in England. Durham University Ph D Thesis, unpublished.
- Coffey, G 1902-4 Some monuments of the La Tène period recently discovered in Ireland, PRIA, 24c, 257-266.
- Coffey, G 1910 Guide to the Celtic Antiquities of the Christian Period in the National Museum, Dublin, 2nd ed.
- Colgrave, B and Mynors, R A B (eds) 1969 Bede's Ecclesiastical History of the English People. Oxford.
- Collingwood, W G 1925 Early carved stones at Hexham, Archaeol Aeliana, 4 ser, 1, 65-92.
- Collingwood, W G 1926 The dispersion of the wheel cross, Yorkshire Archaeol J, 28, 322-31.
- Collingwood, W G 1927 Northumbrian Crosses of the Pre Norman Age. London.
- Conway, V 1975 The Granite Crosses of the Barrow Valley. University College, Dublin MA Thesis, unpublished.
- Cooke, T L 1853 The ancient cross of Banagher, King's County, Trans Kilkenny and SE Ir Archaeol Soc, 2, 277-80.

- Cooke, T L 1875 The Early History of the Town of Birr and Parsonstown. Dublin.
- Cramp, R J 1965 Early Northumbrian Sculpture. Jarrow Lecture. Jarrow.
- Cramp, R J 1970 'Decorated Window-Glass and Millefiori from Monkwearmouth, Antiquaries J, 50, 327-35.
- Cramp, R J 1974 Early Northumbrian Sculpture at Hexham in Kirby 1974, 115-40.
- Cramp, R J 1977 Schools of Mercian Sculpture in Dornier, A, (ed), Mercian Studies, Leicester, 191-234.
- Cramp, R J 1978 The Anglian Tradition in the ninth century in Lang 1978, 1-16.
- Cramp, R J (ed) forthcoming Corpus of Anglo-Saxon Stone Sculpture, London.
- Crawford, H S 1907a A Descriptive list of Irish high crosses, JRSAI, 37, 187-239.
- Crawford, H S 1907b Bealin cross, Twyford, Co Westmeath, JRSAI, 37, 320-2.
- Crawford, H S 1908a Some crosses not mentioned in the list of Irish crosses, JRSAI, 38, 181-2.
- Crawford, H S 1908b Description of a carved stone at Tybroughney, Co Kilkenny, JRSAI, 38, 270-77.
- Crawford, H S 1909a Some early monuments in the Glen of Aherlow, JRSAI, 39, 59-69.
- Crawford, H S 1909b Notes on the crosses and carved doorways at Lorrha, in North Tipperary, JRSAI, 39, 126-31.
- Crawford, H S 1909c The Crosses of Kilkieran (Co Kilkenny) and Ahenny (Co Tipperary), JRSAI, 39, 256-60.
- Crawford, H S 1910 Note on the high cross of Clonmacnoise, JRSAI, 40, 356.
- Crawford, H S 1912 A Descriptive list of early cross slabs and pillars, JRSAI, 42, 217-44.
- Crawford, H S 1913 A Descriptive list of early cross slabs and pillars, JRSAI, 43, 151-169, 261-5, 326-34.
- Crawford, H S 1916 Supplementary list of early cross slabs and pillars, JRSAI, 46, 163-7.
- Crawford, H S 1918 Supplementary list of early Irish crosses, JRSAI, 48, 174-9.

- Crawford, H S 1922 Mona Incha cross, JRSAI, 52, 81.
- Crawford, H S 1923 A descriptive list of Irish shrines and reliquaries, JRSAI, 53, 74-93, 151-76.
- Crawford, H S 1926a Handbook of Carved Ornament from Irish monuments in the Christian Period. Dublin.
- Crawford, H S 1926b The early crosses of East and West Meath, 56, 1-10, 71-81.
- Crawford, H S 1927 The early crosses of East and West Meath, 57, 1-6.
- Crawford, O G S 1937 The vine scroll in Scotland, Antiquity, 11, 469-73.
- Crawford, W C 1919-20 Notes on the grave slabs at Keills, Knapdale, Argyle, PSAS, 54, 248-52.
- Cruden, S 1964 The Early Christian and Pictish monuments of Scotland. Edinburgh.
- Cunningham, G 1976 Roscrea and District. Roscrea.
- Curle, C 1939-40 The chronology of the Early Christian monuments of Scotland, PSAS, 74, 60-116.
- Dalton, O M 1909 Catalogue of the Ivory Carvings of the Christian Era in the British Museum. London.
- Dalton, O M 1911 Byzantine Art and Archaeology. Oxford.
- Davies, O 1938 Clogher crosses and other carved stones, UJA, 3 ser, 1, 227-30.
- Davis-Weyer, C 1971 Early Medieval Art 300-1150: Sources and Documents. Eaglewood Cliffs, N.J.
- De Palol, P and Hirmer, M 1967 Early Medieval Art in Spain. London.
- de Paor, L 1955-6 The limestone crosses of Clare and Aran, J. Galway Archaeol. Hist Soc, 26, 53-71.
- de Paor, M 1977 The Viking Impact in Cove, P (ed), Treasures of Early Irish Art 1500BC to 1500AD. New York, 144-86.
- de Paor, M and L 1960 Early Christian Ireland, London. 2nd ed.
- De Wald, E T 1930 The Stuttgart Psalter. Princeton.
- Dolley, R C M 1966 The Hiberno-Norse coins in the British Museum. London.
- Dorigo, W 1971 Late Roman Painting. London.
- Duignan, M 1944 Early monastic site at Peakawn, Co Tipperary, JRSAI, 74, 226-7.

- Duignan, M 1976 The Turoe Stone in Duval, P-M, and Hawkes, C (eds), Celtic Art in Ancient Europe, five Protohistoric centuries, London, 201-212.
- Dumville, D N 1973 Biblical Apocrypha and the Early Irish: a preliminary investigation, PRIA, 73c, 299-338.
- Dunraven, Earl of 1875-7 Notes on Irish Architecture, Stokes, M (ed). London, 2 vols.
- Durliat, M 1953 Un groupe de sculpture wisigothiques à Narbonne, Études Mérovingiennes, 93-101.
- Edwards, N 1976 The Problem of the possible connection between the interlace motives in Coptic and Early Christian Celtic art with particular reference to Coptic Textiles. Liverpool University BA dissertation, unpublished.
- * Evans, E 1957 Irish Folk Ways, London.
- Evans, E 1966 Prehistoric and Early Christian Ireland, a guide. New York.
- Farnes, E 1975 Some aspects of the relationship between late eleventh and twelfth century Irish art and the Scandinavian Urnes Style. University College, Dublin, MA Thesis, unpublished.
- Farrell, R T (ed). 1974 Daniel and Azarias. London.
- Ffrench, J F M 1892 St Mullins, Co Carlow, JRSAI, 22, 384.
- Finlay, I 1973 Celtic Art - an Introduction. London.
- Fitzgerald, Lord W 1899 On the holed cross at Moone, JRSAI, 29, 385-9.
- Fitzmaurice, B 1970 A survey of the Pre-Norman crosses of Co Carlow, Carloviana, Dec 1970, 31-2
- Flower, R 1927 Ireland and Medieval Europe, Proc Brit Acad, 13, 271-303.
- Flower, R 1954 Irish high crosses, J Warburg Courtauld Inst, 17, 87-97.
- Fossard, D 1953 Répartition des Sarcophages mérovingiens, Études Mérovingiennes, 117-26.
- Fox, C 1958 Pattern and Purpose, Cardiff.
- Freeman, T W 1965 Ireland, a general and regional geography. London, 3rd ed.
- Friend, A M 1939 The Canon Tables of the Book of Kells, in Koehler, W R W (ed). Medieval Studies in memory of Kingsley-Porter, Cambridge, Mass., 611-66.
- * Elbern, V H 1965 Liturgisches Gerät in edlen Materialien zur Zeit Karls des Grossen, in Braunfels, W and Schnitzler H (eds) Karl der Große. Düsseldorf III, 115-14

- Gaborit-Chopin, D 1978 Ivoires du Moyen Age. Fribourg.
- Galpin, F W 1913 Ullard: its church and its cross, Antiquary, 49, 11-4.
- Gillespie, P 1918-9 Note on the sculptured figure of a stag on the cross shaft at Clonmacnois, Ireland, in relation to the ancient wooden objects known as otter or beaver traps, PSAS, 53, 165-7.
- Gilling, F H 1937 Ancient carved cross-base at Seir Kieran, Offaly, JRSAI, 67, 294-5.
- Gleeson, D F 1947 Roscrea, Town and Parish. Dublin.
- Gleeson, J 1915 History of Ely O'Carroll. Dublin.
- Gogan, L S 1932 The Ardagh Chalice. Dublin.
- Goldschmidt, A 1918 Die Elfenbeinskulpturen aus der zeit der Karolingischen und sächsischen Kaiser VIII-XI Jahrhundert. Berlin, 2 vols.
- Gordon, R K 1954 Anglo-Saxon Poetry. London.
- Gougaud, L 1920 The earliest Irish representation of the Crucifixion, JRSAI, 50, 128-39.
- Gougaud, L 1932 Christianity in Celtic Lands, London.
- Gough, M 1973 The Origins of Christian Art. London.
- Grabar, A 1958 Les Ampoules de Terre Sainte. Paris.
- Grabar, A 1969 Christian Iconography, a study of its origins. London.
- Graham-Campbell, J A 1972 Two groups of ninth-century Irish brooches, JRSAI, 102, 113-28.
- Graham-Campbell, J A 1973-4 The Lough Ravel, Co Antrim, Brooch and others of ninth century date, UJA, 36-7, 52-7.
- Graham-Campbell, J A 1975 Bossed penannular brooches: a review of recent research, Medieval Archaeol, 19, 33-47.
- Graham-Campbell, J A 1978-9 The initial impact of the Vikings on Irish art, Sagabook, 20, 42-8.
- Graves, J 1871 (On Banagher) JRSAI, 11, 201.
- Greene, D 1972 The chariot as described in Irish literature, in Thomas, C (ed), The Iron Age in the Irish Sea Province, CBA research report 9, London, 59-73.
- Greenwell, W 1899 A Catalogue of the sculptured and inscribed stones at the Cathedral Library, Durham. Durham.

- Grondjis, L H 1935 Le Soleil et la Lune dans les scènes de la Crucifixion, Congrès international Études byzantines, Sofice, 250-4.
- Grosset, C 1953 L'Origine du thème roman de Daniel, Études Mérovingiennes, 147-56.
- Gwynn, E J and Purton, W J 1911-2 The monastery of Tallaght, PRIA, 29c, 115-78.
- Hadcock, R N 1960 The Map of Monastic Ireland. Ordnance Survey, Dublin.
- Haig, E 1908 The Volto Sancto of Lucca, The Reliquary and Illustrated Archaeologist, 14, 264-9.
- Hamlin, A 1972 A chi-rho carved stone at Drumaqueran, Co Antrim, UJA, 35, 22-8.
- Harbison, P 1969 The chariot of Celtic funerary tradition in Frey, O H (ed), Marburger Beiträge zur Archäologie der Kelten, Festschrift Dehn, Fundberichte aus Hessen, 1, 34-58.
- Harbison, P 1970 How old is Gallarus Oratory? A reappraisal of the role of Gallarus Oratory in Early Irish architecture, Medieval Archaeol, 14, 34-59.
- Harbison, P 1971 The Old Irish chariot, Antiquity, 45, 171-7.
- Harbison, P 1975 Guide to the National Monuments of Ireland. Dublin, 2nd ed.
- Harbison, P 1978 On some possible sources of the Irish high cross decoration, Festschrift zum 50 jährigen Bestehen des Vorgeschichtlichen Seminars Marburg, Band 1, 283-97.
- Harbison, P 1979 The inscriptions on the Cross of the Scriptures at Clonmacnois, Co Offaly, PRIA, 79c, 177-88.
- Harbison, P et al 1978 Irish Art and Architecture from Prehistory to the Present. London.
- Harting, J E 1880 British Animals extinct within Historic Times. Chicheley, 1972 reprint.
- Haseloff, G 1958 Fragments of a hanging-bowl from Bekesbourne, Kent, and some ornamental problems, Medieval Archaeol, 2, 72-103.
- Hatt, J-J 1980 Eine Interpretation der Bilder und Szenen auf dem Silberkessel von Gundestrup, Die Kelten in Mitteleuropa, Salzburg, 68-75.

- Hautecoeur, L 1921 Le Soleil et la Lune dans les Crucifixions,
Revue Archæologique, 5 ser, 14, 13-32.
- Hemphill, S 1911 The Gospels of Mac Regol of Birr: a study in
Celtic illumination, PRIA, 29c, 1-10.
- Hencken, H O'N 1935-7 Ballinderry Crannog No. 1, PRIA, 43c, 103-239.
- Hencken, H O'N 1950-1 Lagore Crannog: an Irish royal residence of
the seventh to tenth centuries AD, PRIA, 53c.
- Henderson, I 1967 The Picts. London.
- Henderson, I 1978 Sculpture north of the Forth after the take-
over by the Scots in Lang 1978, 47-73.
- Hennessy, W M (ed) 1886 Chronicum Scottorum: a chronicle of Irish
affairs from the earliest times to AD 1135 with a
supplement 1141-50. London.
- Hennessy, W M and 1887-1901 Annála Ulidh: Annals of Ulster, otherwise
MacCarthy, B (eds) Annála Senat: a chronicle of Irish affairs, 431-1131,
1155-1541. Dublin, 4 vols.
- Henry, F 1930a Les Origines de l'iconography irlandaise,
Revue Archéologique, 5 ser, 32, 89-109.
- Henry, F 1930b L'Inscription de Bealin, Revue Archéologique,
5 ser, 32, 110-5.
- Henry, F 1933 La Sculpture Irlandaise pendant les douze
premiers siècles de l'ère chrétienne, Paris.
- Henry, F 1936 Hanging Bowls, JRSAI, 46, 209-46.
- Henry, F 1937 Early Christian slabs and pillar stones in
the west of Ireland, JRSAI, 67, 265-79.
- Henry, F 1938 Deux objets irlandais au Musée des
Antiquités nationales, Préhistoire, 6, 65-91.
- Henry, F 1940 Irish Art. London.
- Henry, F 1945 The seven bishops, Béaloides, 15, 257-60.
- Henry, F 1950 Les débuts de la miniature irlandaise,
Gazette des Beaux Arts, 37, 5-34.
- Henry, F 1957 An Irish manuscript in the British Museum
(Add, 40. 618), JRSAI, 87, 147-66.
- Henry, F 1960 Remarks on the decoration of three Irish
psalters, PRIA, 61c, 23-40.
- Henry, F 1963 A cross at Durrow (Offaly), JRSAI, 93, 83-4.
- Henry, F 1964 Irish High Crosses. Dublin.
- Henry, F 1965 Irish Art in the Early Christian Period (to
800AD). London.

- Henry, F 1967 Irish Art during the Viking invasions (800-1020 AD). London.
- Henry, F 1970 Irish Art during the Romanesque period (1020-1170AD). London.
- Henry, F 1974 The Book of Kells with a study of the manuscript. London.
- Henry, F 1975 The effects of the Viking invasions on Irish art on O'Cuiv 1975, 61-72.
- Henry, F 1980 Around an inscription: the Cross of the Scriptures at Clonmacnois, JRSAI, 110, 36-45.
- Henry, F and Ó Riordáin, S P 1948 Irish learning in the seventh century, Studies, 37, 267-82.
- Henry, F and Marsh-Micheli, G L 1962 A century of Irish illumination, PRIA, 62c, 101-64.
- Herity, M 1974 Irish Passage Graves. Dublin.
- Herren, M W (ed) 1974 The Hesperica Famina I, the A-Text. Toronto.
- Hickey, E 1955 North Cross at Ahenny, JRSAI, 85, 118-21.
- Hickey, H 1976 Images of Stone. Belfast.
- Hickey, H 1977 The Master of White Island, Ireland of the Welcomes, 26(1), 10-5.
- Hicks, C 1980 A Clonmacnois workshop in stone, JRSAI, 110, 47-51.
- Hillgarth, J N 1961 The East, Visigothic Spain and the Irish, Studia Patristica, 79, 442-56.
- Hillgarth, J N 1961-2 Visigothic Spain and Early Christian Ireland, PRIA, 62c, 167-94.
- Hitchcock, F R M 1917 The Kinnity stone, JRSAI, 47, 185.
- Holmquist, W 1955 An Irish crozier-head found near Stockholm, Antiq. J., 1955, 46-51.
- Howlett, D R 1974 The iconography of the Alfred Jewel, Oxoniensia, 39, 44-52.
- Hovey, W R 1928 Sources of Irish illuminative art, Art Studies, 6, 105-20.
- Hubert, J et al 1967, Europe in the Dark Ages. London.
- Hughes, K 1958 The distribution of Irish Scriptoria and centres of learning from 730-1111 in Chadwick, N K et al, Studies in the Early British Church. Cambridge, 243-72.

- Hughes, K 1963 Irish monks and learning, Monjes y los estudios, 4, semana de estudios monasticos, Poblet, 1961. Poblet.
- Hughes, K 1966 The Church in Early Irish Society. London.
- Hughes, K 1968 Introduction in Otway-Ruthven, A J, A History of Medieval Ireland. London.
- Hughes, K 1971 Evidence for contacts between the churches of the Irish and English from the synod of Whitby to the Viking Age in Clemons, P and Hughes, K (eds), England before the Conquest: Studies in Primary sources presented to Dorothy Whitelock, Cambridge, 49-68.
- Hughes, K 1972 Early Christian Ireland: Introduction to the Sources. Cambridge.
- Hughes, K 1980 Celtic Britain in the Early Middle Ages. Woodbridge and Totawa (USA).
- Hughes, K and Hamlin, A 1977 The Modern Traveller in the Early Irish Church. London.
- Hulme, E 1899 Symbolism in Christian Art. London.
- Hunt, J 1951 The cross of Muiredach, Monasterboice, JRSAI, 81, 44-7.
- Hunt, J 1956 On two 'D' shaped objects in the Saint-Germain Museum, PRIA, 57c, 153-7.
- Hunt, J (ed) 1967 Rosc Exhibition 1967: Catalogue to the Exhibition of Ancient Celtic Art, Dublin.
- Hunt, J 1974 Irish Medieval figure sculpture. Dublin.
- Huskinson, J 1974 Some pagan mythological figures and their significance in Early Christian art, Pap Brit Sch Rome, 29, 68-97.
- Ireland 1907 Seventy fifth Annual Report from the Commissioners of Public Works. Dublin.
- Jackson, K H 1953 Language and History in Early Britain. Edinburgh.
- Jackson, K H (ed) 1969 The Gododdin. Edinburgh.
- James, M R (ed) 1924 The Apocryphal New Testament. Oxford.
- James, M R (ed) 1929 B.M. Cotton MS. Vitellius A XV, facsimile by the Roxburghe Club. Oxford.
- Jones, G 1968 A History of the Vikings. Oxford.

- Jope, E M 1955 Chariotry and paired-draught in Ireland during the Early Iron Age, UJA, 18, 37-44.
- Jope, E M and Wilson, B C S 1957 A decorated cast bronze disc from the River Bann near Coleraine, UJA, 20, 95-102.
- Keane, M 1867 The Towers and Temples of Ancient Ireland. Dublin.
- Kendrick, T D 1938 Anglo-Saxon Art to AD900. London.
- Kendrick, T D 1939 Gallen Priory, 'Kings County', excavations 1934-5, JRSAL, 69, 1-20.
- Kendrick T D 1949 Late Saxon and Viking Art. London.
- Kendrick T D and Senoir, E 1936 St Manchan's shrine, Archaeologia, 86, 105-18.
- Kendrick, T D et al 1960 Evangelarum Quattuor Codex Lindisfarnensis. Olten/Lausanne, 2 vols.
- Kenney, J 1929 Sources for the Early History of Ireland - An Introduction and Guide, Vol I Ecclesiastical. New York.
- Kermode, P M C 1910 Manx Crosses. London.
- Kilbride-Jones, H E 1937 The evolution of the penannular brooch with zoomorphic terminals, PRIA, 43c, 379-455.
- Killanin, Lord and Duignan, M V 1967 The Shell Guide to Ireland. London.
- [†] Kinsella, T (trans) 1969 The Táin. Dublin and London.
- Kirby, D P (ed) 1974 St Wilfred of Hexham. Newcastle.
- Knoop, D and Jones, G P 1947 The Medieval Mason. Manchester.
- Köhler, W 1930 Die Karolingischen Miniaturen im Auftrage des Deutschen Vereins für Kunstwissenschaft, I.1 Die Schule von Tours. Berlin.
- Köhler, W 1933 Die Karolingischen Miniaturen im Auftrage des Deutschen Vereins für Kunstwissenschaft, I.2 Die Schule von Tours. Berlin.
- Köhler, W 1958 Die Karolingischen Miniaturen im Auftrage des Deutschen Vereins für Kunstwissenschaft, II Die Hofschule Karl des Grossen. Berlin.
- Kuhn, S H 1948 from Canterbury to Lichfield, Speculum, 23 591-629.
- Lahert, R N.D. History and Antiquities of the Parish of Dunnamaggan.
- [‡] King, J E (trans) 1963 Bede's Lives of the Abbots. London and Cambridge (U.S.A.).

- Lang, J T 1971 The Castledermot hogback, JRSAI, 101, 154-8.
- Lang, J T 1972-4 Hogback monuments in Scotland, PSAS, 105, 206-35.
- Lang, J T (ed) 1978 Anglo-Saxon and Viking Age Sculpture, Brit Archaeol Rep (Brit ser) 49.
- Lanigan, J 1822 An ecclesiastical history of Ireland to the beginning of the thirteenth century, Dublin, 4 vols.
- Lasko, P 1971 The Kingdom of the Franks, North West Europe before Charlemagne. London.
- Lasko, P 1972 Ars Sacra 800-1200. Harmondsworth.
- Lathey, C 1948 The Book of Daniel. Dublin.
- Lawless, N 1920 Dromiskin Celtic Cross, Louth Archaeol J, 7, 301-
- Lawlor, H J 1894-5 Notes on some Non-Biblical matter in the manuscript of the Four Gospels known as the Book of Mulling, PSAS, 17, 11-45.
- Lawlor, H J 1897 Chapters on the Book of Mulling. Edinburgh.
- Leask, H G 1941 Irish architecture and sculpture during the Early Christian Period in Raftery, J 1941
- Leask, H G 1951 St Patrick's Cross, Cashel, Co Tipperary, an enquiry into its original form, JRSAI, 81, 14-8.
- Leask, H G 1955 Irish Churches and Monastic Buildings, I The first phases and the Romanesque, Dundalk.
- Le Blant, E 1878 Étude sur les Sarcophages chrétiens antiques de la Ville d'Arles. Paris.
- Le Blant, E 1886 Les Sarcophages chrétiens de la Gaule. Paris.
- Ledwich, E 1804 The antiquities of Ireland. Dublin.
- Leeds, E T 1933 Celtic Ornament in the British Isles down to 700AD. Oxford.
- Leroquais, C V 1940-1 Les Psautiers Manuscrits Latins des Bibliothèques Publiques de France. Macon.
- Lewis, A 1953 Le commerce maritime et les navires de la Gaule occidentale, Études Mérovingiennes, 191-9.
- Lionard, P 1960-1 Early Irish grave slabs, PRIA, 61c, 95-169.
- Lothar, H 1929 Der Pfau in der Altchristlichen Kunst, Studien über Christliche Denkmäler, 18 Heft. Leipzig.

- Lowry-Corry, D 1932-4 The stones carved with human effigies on Boa Island and on Lustymore Island, in Lower Lough Erne, PRIA, 41c, 200-4.
- Lowry-Corry, D 1934 The sculptured crosses of Galloon, Co Fermanagh, JRSAI, 64, 165-76.
- Lowry-Corry, D 1935 The Market cross at Lisnaskea, JRSAI, 65, 153-5.
- Lucas, A T 1951 The West cross, Monasterboice: a note and a suggestion, J Co Louth Archaeol Soc, 12, 123-5.
- Lucas, A T 1966 Irish-Norse relations: Time for a re-appraisal? J Cork Hist Archaeol Soc. 42, 62-75.
- Lucas, A T 1967 The plundering and burning of churches in Ireland, seventh to sixteenth century in Rynne 1967, 172-229.
- Macalister, R A S 1908 Some notes on the sculptured slabs at Gallen Priory, JRSAI, 38, 323-7.
- Macalister, R A S 1909 The memorial slabs of Clonmacnoise, King's County: with an appendix on the materials for the history of the Monastery. Dublin.
- Macalister, R A S 1922 A stone with La Tène decoration recently discovered in Co Cavan, JRSAI, 52, 113-6.
- Macalister, R A S 1928 The Archaeology of Ireland. London.
- Macalister, R A S 1929 The inscription on the slab at Fahan Mura, Co Donegal. JRSAI, 59, 89-98.
- Macalister, R A S 1932 The panel representing the Traditio Evangelii on the Cross of Muiredach at Monasterboice. JRSAI, 62, 15-8.
- Macalister, R A S 1937 The story of Clonmacnois, Proc Belfast Natur Hist Philosophical Soc, 2 ser, 1, 9-11.
- Macalister, R A S 1945 Corpus Inscriptionum Insularum Celticarum, I Dublin.
- Macalister, R A S 1946 Monasterboice, Dundalk.
- Macalister, R A S 1949 Corpus Inscriptionum Insularum Celticarum, II Dublin
- Macdermot, M 1954 An openwork Crucifixion plaque from Clonmacnoise, JRSAI, 84, 36-40.
- Macdermot, M 1955 The Kells crozier, Archaeologia, 96, 59-113.
- Macdermot, M 1957 The crosiers of St Dymphna and St Mel and tenth century Irish metalwork, PRIA, 58c, 167-95.

- Macdonald, A 1973 Two major monasteries of Dalriata: Lismore and Eigg, Scot Archaeol Forum, 5, 47-70.
- Mac Niocaill, G 1972 Ireland before the Vikings. Dublin.
- Mac Niocaill, G 1975 The Medieval Irish annals, Medieval Ir Hist Ser, 3, Dublin.
- Mac White, E 1946 A new view on Irish Bronze Age rock-scribings, JRSAI, 76, 59-80.
- Mahr, A 1932 Christian Art in Ancient Ireland, I. Dublin.
- Mâle, E 1922 L'art religieux du XIIe siècle en France. Paris.
- Masai, F 1947 Essai sur les origines de la miniature dite irlandaise. Brussels.
- Mason, T H 1942 The Devil as depicted on Irish high crosses, JRSAI, 72, 131-5.
- McGurk, P 1956 The Irish pocket Gospel-Books, Sacris Erudiri, 249ff.
- McLoughlin, E 1969 OE Exodus and the Antiphony of Bangor, Neuphilologische Mitteilungen, 70, 658-67.
- McNamara, M 1973 Psalter text and Psalter study in the Early Irish Church (AD600-1200), PRIA, 73c, 201-98.
- McNeill, C and Leask, H G 1920 Mona Incha, Co Tipperary, JRSAI, 50, 19-35.
- Meehan, D (ed) 1958 Adomnan's De Locis Sanctis, Scriptores Latini Hiberniae, 3. Dublin.
- Meyer, K 1904 Poem of the Cross of Christ, Ériu, 1, 41-2.
- Meyer, K 1911 Selections from Early Irish Poetry. London.
- Michel, J Geberht und Bild in Fruchchristlicher Zeit in Ficker, J (ed) Studien über christlicher Denkmäler, Neue Folge der Archäologischen Studien zum christlichen Altertum und Mittelalter, Leipzig, 127-36.
- Michel, P H 1958 L'Iconographie de Cain et Abel, Cahiers de Civilisation Médiévale X-XII siècle, 1, 194-9.

- Micheli, G L 1939 L'Enluminure du haut moyen âge et les influences irlandaises. Brussels.
- Migne, J P (ed) 1844-64 Patrologiae Cursus Completus, Series (Latina) prima. Paris, 221 vols.
- Migne, J P (ed) 1857-1912 Patrologiae Cursus Completus, Series Graeca. Paris, 162 vols.
- Moe, O H 1955 Urnes and the British Isles, Acta Archaeologica, 26, 1-30.
- Moloney, M 1962-5 Beccan's hermitage in Aherlow: the riddle of the slabs, North Munster Archaeol J, 9, 99-107.
- Moore-Smith, A 1922 The iconography of the Sacrifice of Isaac in Early Christian art, American J of Archaeol, 26, 159-73.
- Morris, C D 1978-9 The Vikings and Irish monasteries, Durham University J, 71, 175-85.
- Morris, H 1934 The Muiredach Cross at Monasterboice, JRSAI, 64, 203-12.
- Mowbray, C 1936 Eastern influence on carvings at St Andrews and Nigg, Scotland, Antiquity, 10, 428-40.
- Murphy, B 1971 Irish high crosses, arrangement and form. University College, Dublin, MA Thesis, unpublished.
- Murphy, D (ed) 1896 The Annals of Clonmacnoise. Dublin.
- Murray, H 1979 Documentary evidence for domestic buildings in Ireland c 400-1200 in the light of archaeology, Medieval Archaeol, 23, 81-97.
- Mütherich, F and Gaedhe, J 1977 Carolingian Painting. London
- Nash-Williams, V E 1950 The Early Christian Monuments of Wales. Cardiff.
- Ní Chatháin, P 1980 The Liturgical background of the Derrynavlan Hoard, JRSAI, 110, 127-48.
- Nordenfalk, C 1947 Before the Book of Durrow, Acta Archaeologica, 18, 141-74.
- Nordenfalk, C 1977 Celtic and Anglo-Saxon Painting. London.
- Norris, H 1949 Church Vestments, their origin and development. London.

- O'Corráin, D 1972 Ireland before the Normans. Dublin.
- O'Dell, A C et al 1959 The St Ninian's Isle Hoard, Antiquity, 33, 241-68.
- O'Donovan, J (ed) 1851 Annála rioghacta Éireann: Annals of the Kingdom of Ireland by the Four Masters from the earliest period to the year 1616. Dublin, 7 vols.
- O'Donovan, J 1926 Letters containing information relative to the antiquities of King's County collected during the progress of the Ordnance Survey 1837-8. National Library of Ireland, typed copy.
- O'Donovan, J 1928a Letters containing information relative to the antiquities of the County of Tipperary collected during the progress of the Ordnance Survey in 1841. National Library of Ireland, typed copy.
- O'Donovan, J 1928b Letters containing information on the County of Kilkenny collected during the progress of the Ordnance Survey in 1839. National Library of Ireland, typed copy.
- O'Donovan, J (trans) 1864 The Martyrology of Donegal - a calendar of the Saints of Ireland. Dublin
- et al
- Ó hÉalidhe, P 1967 The crosses and slabs at St Berrihert's Kyle in the Glen of Aherlow in Rynne 1967, 102-26.
- O'Keefe, J G 1907 A Poem on the Day of Judgement, Ériu, 3, 29-33.
- O'Kelly, M J 1962-4 Two ring forts at Garryduff, Co Cork, PRIA, 63c, 17-125.
- O'Kelly, M J 1964 The belt shrine from Moylough, Sligo, JRSAI, 95, 149-88.
- O'Meadhra, U 1979 Early Christian, Viking and Romanesque art, Motif Pieces from Ireland. Stockholm
- Ó Murchadha, D 1980 Rubbings taken of the inscriptions on the Cross of Scriptures, Clonmacnois, JRSAI, 110, 47-51.
- O'Murnaghan, A 1945-8 A note on the Cross in Irish Archaeology, J Co Louth Archaeol Soc, 11, 61-2.

- O'Neill, H 1857 Illustrations of the most interesting of the Sculptured crosses of Ancient Ireland. London.
- Organ, R M 1973 Examination of the Ardagh Chalice: a case history in Young, W J (ed), The Application of Science in Examination of works of art, Boston, 238-71.
- Ó Riordáin, B 1980a Treasure Trove, Ireland of the Welcomes, 29(5), 14-8.
- Ó Riordáin, B 1980b The Derrynaflan Hoard, Antiquity, 54, 216-7.
- Ó Riordáin, S P 1947 The genesis of the Celtic high cross in Pender, S (ed), Féilscríbhinn Torna, Cork, 108-14.
- Perkins, J B W 1937 The sculpture of Visigothic France, Archæologia, 87, 79-128.
- Peterson, J 1940 Viking Antiquities in Great Britain and Ireland, Shetelig, H (ed), Part 5 British Antiquities of the Viking period, found in Norway, Oslo.
- Petrie, G 1845 The Ecclesiastical Architecture of Ireland, anterior to the Anglo-Norman invasion, comprising an essay on the origins and uses of round towers in Ireland. Dublin.
- Petrie, G 1872 and 1878 Christian Inscriptions in the Irish Language, Stokes, M (ed). Dublin, 2 vols.
- Pillsworth, W J 1953 History of Thomastown and district. Kilkenny.
- Plenderleith, H J 1968 Problems in the preservation of monuments, The Conservation of Cultural Property, Museums and Monuments, 11, Unesco, Switzerland.
- Plummer, C (ed) 1896 Venerabilis Baedae Opera Historica. London, Vol. 1.
- Plummer, C (ed) 1910 Vitae Sanctorum Hibernae. London, 2 vols.
- Plummer, C (ed) 1922 Bethada Náem nErenn, Lives of Irish Saints. Oxford, 2 vols.
- Plummer, C (ed) 1925 Irish Litanies, Henry Bradshaw Soc, 62, London.

- Porter, A K 1929 Notes on Irish Crosses in Konsthistoriska Studier, Johnny Roosval, Stockholm, 85-94.
- Porter, A K 1931 The Crosses and Culture of Ireland. New Haven, USA.
- Power, P 1897 Curious inscribed stone at Tybroughney, J Waterford SE Ir Archaeol Soc, 3, 47-8.
- Power, P 1906 The Celtic crosses of Kilkieran, Kilklispeen and Killamery, J Waterford SE Ir Archaeol Soc, 9 supplement, 1-20.
- Prendergast, E 1964 A new high cross at Leggetttsrath, near Kilkenny, Old Kilkenny Rev, 16, 5-16.
- Purser, O 1918 Fragment of a Celtic cross found at Drumcullin, King's County, JRSAI, 48, 74-7.
- Radford, C A R 1942 The Early Christian monuments of Scotland, Antiquity, 16, 1-18.
- Radford, C A R 1977 The Mediterranean sources of sculpture in stone among the insular Celts and the survival into the full Medieval Age in Laing, L R (ed), Studies in Celtic Survival, Brit Archaeol Rep, Brit ser, 37, 113-23.
- Raftery, B 1978 Excavations at Killycluggin, Co Cavan, UJA, 41, 49-54.
- Raftery, J 1941 Christian Art in Ancient Ireland, Vol. 2. Dublin.
- Raftery, J 1944 The Turoe stone and the rath of Feerwore, JRSAI, 74, 23-52.
- Raleigh, R A 1975 The Late High Crosses of Ireland. University College, Dublin MA Thesis, unpublished.
- Réau, L 1955 L'Art Chrétien, I: Introduction générale. Paris.
- Réau, L 1956-7 L'Art Chrétien, II: Iconographie de la Bible. Paris, 2 parts.
- Reece, R 1977 Mosaics and Carpets in Munby, J and Henig, M (eds), Roman Life and Art in Britain, Brit Archaeol Rep, Brit ser, 41(2), 407-13.
- Reeves, W (ed) 1857 The Life of St Columba, founder of Hy, written by Adomnan. Dublin.
- Robertson, J N 1974-5 St John's Cross Iona, Argyle, PSAS, 106, 111-23.

- Robin, P A 1932 Animal Lore in English Literature. London.
- Roe, H 1945 An interpretation of certain symbolic sculptures of Early Christian Ireland, JRSAI, 75, 1-23.
- Roe, H 1949 The 'David Cycle' in Early Irish art, JRSAI, 79, 39-59.
- Roe, H 1954 Antiquities of the Archdiocese of Armagh, Co Louth, Seanchas Ardmacha, 1, 101-114.
- Roe, H 1955 Antiquities of the Archdiocese of Armagh, Co Armagh, Seanchas Ardmacha, 2, 107-112.
- Roe, H 1956 Antiquities of the Archdiocese of Armagh, Co Tyrone, Seanchas Ardmacha, 3, 79-88.
- Roe, H 1962 The High Crosses of Western Ossory. Kilkenny, 2nd ed.
- Roe, H 1965 The Irish high cross: morphology and iconography, JRSAI, 95, 213-26.
- Roe, H 1966 The High Crosses of Kells. Dublin, 2nd ed.
- Roe, H 1967 The Roscrea pillar in Rynne 1967, 127-32.
- Roe, H 1970 The orans in Irish Christian art, JRSAI, 100, 212-221.
- Rosenbaum, E 1956 The Evangelist portraits of the Ada School and their models, Art Bulletin, 38(2), 81-90.
- Ross, A 1967 Pagan Celtic Britain. London.
- Ryan, J 1931 Irish Monasticism: origins and early development. Dublin.
- Ryan, J 1940 The abbatial succession of Clonmacnoise, from the foundation of the monastery to the coming of the Norse, AD 545-799 in Ryan, J (ed) Essays presented to Eoin MacNeill, Dublin, 490-507.
- Ryan, J 1950 Irish learning in the seventh century, JRSAI, 80, 164-71.
- Ryan, J 1973 Clonmacnois, a historical summary. Dublin.
- Ryan, M 1980 The Derrynaflan Hoard, Ireland Today, Bulletin of the Dept of Foreign Affairs, 965, 1-5.
- Rynne, E (ed) 1967 North Munster Studies. Limerick.

- Savory, H 1960 Excavations at Dinas Emrys, Beddgelert, (Caern) 1954-56, Archaeol Cambrensis, 109, 13-77.
- Sawyer, P H 1970 The Vikings and the Irish Sea in Moore, D (ed), The Irish Sea Province in Archaeology and History, Cardiff.
- Saxl, F 1943 The Ruthwell cross, J Warburg Courtauld Inst, 6, 1-19.
- Saxl, F and Wittkower R W 1948 British Art and the Mediterranean. London.
- Schapiro, M 1942 "Cain's jaw-bone that did the first murder", Art Bulletin, 24, 205-12.
- Schapiro, M 1943 The Angel and the ram in Abraham's Sacrifice: a parallel in Western and Islamic art, Ars Islamica, 10, 134-47.
- Schapiro, M 1944 The Religious meaning of the Ruthwell cross, Art Bulletin, 26, 232-45.
- Schapiro, M 1950 Review of 'Masai, F, Essai sur les origines de la miniature dite irlandaise', Gazette des Beaux-Arts, 37, 134-8.
- Schapiro, M 1958 The decoration of the Leningrad manuscript of Bede, Scriptorium, 191ff.
- Schapiro, M 1963 The bowman and the bird on the Ruthwell cross and other work: the interpretation of secular themes in Early Medieval religious art, Art Bulletin, 45, 351-5.
- Schapiro, M 1967 An Irish-Latin text on the Angel with the ram in Abraham's Sacrifice in Fraser, D et al (eds), Essay in the History of Art presented to Rudolf Wittkower, 17-9.
- Schiller, G 1971 Iconography of Christian Art I. Gütersloh, London, trans Seligman, J.
- Schiller, G 1972 Iconography of Christian Art II. Gütersloh, London, trans Seligman, J.
- Sexton, E H L 1946 Irish figure sculpture of the Early Christian Period. Portland, Maine.
- Seymour, J D 1922 The Book of Adam and Eve in Ireland, PRIA, 36c, 121-33.
- Shearman, J F 1874-5a Loca Patriciana Part VIII, JRSAI, 13, 381-42.

- Shearman, J F 1874-5b Loca Patriciana Part IX, JRSAI, 13, 487-529.
- Shelby, L R 1965 Medieval mason's tools II: compass and square, Technology and Culture, 6, 236-48.
- Shetelig, H (ed) 1940-54 Viking Antiquities in Great Britain and Ireland, Oslo, 6 parts.
- Shetelig, H 1948 Norse style ornament in the Viking settlements, Acta Archaeologica, 19, 69-113.
- Small, A et al 1973 St Ninian's Isle and its Treasure. Oxford.
- Smyth, A P 1975, 1979 Scandinavian York and Dublin. New Jersey and Dublin, 2 vols.
- Stevenson, R B K 1955 Pictish art in Wainwright, F T (ed), The Problem of the Picts, Edinburgh and London, 97-128.
- Stevenson, R B K 1956 The chronology and relationships of some Irish and Scottish crosses, JRSAI, 86, 84-96.
- Stevenson R B K 1958-9 The Inchyra stone and other unpublished Early Christian monuments, PSAS, 92 33-5.
- Stevenson, R B K 1970 Sculpture in Scotland in the sixth - ninth centuries AD, Kolloquium über Spätantike und Frühmittelalterliche Sculptur, Mainz, 65-74.
- Stevenson, R B K 1974 The Hunterston Brooch and its significance, Medieval Archaeol, 18, 16-42.
- Stokes, M M 1895 Celtic crosses at Castledermot, J Kildare Archaeol Soc, 1, 281-5.
- Stokes M M 1898 The High Crosses of Castledermot and Durrow, with an introduction to the high crosses of Ireland. Dublin.
- Stokes, M M 1899 The holed cross at Moone, J Kildare Archaeol Soc, 3, 33-8.
- Stokes, M M 1901 Notes on the high crosses of Moone, Drumcliff, Termonfechin and Killamery, Trans Roy Ir Acad, 31, 541-78.
- Stokes, M M 1911 Early Christian Art in Ireland, Dublin, Plunkett, Count (ed).

- Stokes, M M and
Fitzgerald, W
Stokes, W
1899 Old Kilcullen, J Kildare Archaeol Soc,
2 431-446.
1879-80 Tidings of Doomsday, an early
middle Irish homily, Revue Celtique, 4,
245-57.
- Stokes, W (ed)
1890 Lives of the saints from the Book of
Lismore, Anecdota Oxoniensia, Oxford.
- Stokes, W (ed)
1895 The Annals of Tigernach, Revue Celtique,
16, 374-419.
- Stokes, W (ed)
1896 The Annals of Tigernach, Revue Celtique,
17, 6-33, 119-263, 337-420.
- Stokes, W (ed)
1897 The Annals of Tigernach, Revue Celtique,
18, 9-59, 150-97, 267, 303.
- Stokes, W
1905a The evernew tongue, Ériu, 2, 96-147.
- Stokes, W (ed)
1905b The Martyrology of Oengus the Culdee,
Henry Bradshaw Soc, 29.
- Stoll, R
1967 Architecture and Sculpture in Early
Britain: Celtic, Saxon, Norman. London.
- Stone, L
1955 Sculpture in Britain, the Middle Ages.
Harmondsworth.
- Stryzowski, J
1901 Orient oder Rom. Leipzig.
- Stryzowski, J
1918 Die Bau Kunst der Armenier und Europa.
Wein, 2 vols.
- Swanton, M (ed)
1970 The Dream of the Rood. Manchester.
- Swarzenski, G
1954 An early Anglo-Irish portable shrine,
Bulletin of the Museum of Fine Arts, Boston,
52, 50-62.
- Szövérfy, J
1966 'Crux Fidelis...' Prolegomena to a
history of the Holy Cross hymns, Traditio,
22, 1-41.
- Talbot-Rice, D
1952 English Art 871-1100. London.
- Taylor, H M and J
1965 Anglo-Saxon Architecture. Cambridge, 2
vols.
- Taylor, H M and J
1966 Architectural sculpture in Pre-Norman
England, J Brit Archaeol Ass, 29, 3-51.
- Thomas, C
1961 The animal art of the Scottish Iron Age
and its origins, Archaeol J, 118, 14-63.
- Thomas, C
1971 The Early Christian Archaeology of North
Britain. Oxford.

- Toynbee, J M C 1964 Art in Britain under the Romans.
Oxford.
- Vigors, P D 1893 The antiquities of Ullard, Co Kilkenny,
JRSAI, 23, 251-60.
- Vogel, C 1975 Introduction aux sources de l'histoire
du Culte Chrétien au Moyen Âge. Spoleto.
- Volbach, W F 1952 Elfenbeinarbeiten der Spätantike und
des frühen Mittelalters. Mainz.
- Volbach, W F 1961 Early Chrstian Art. London.
- Wakeman, W F 1892 A survey of the antiquarian remains of
the island of Inismurray, JRSAI, special
volume. London and Edinburgh.
- Wallace-Hadrill, D S 1968 The Greek Patristic view of nature.
Manchester.
- Walsh, A 1922 Scandinavian relations with Ireland
during the Viking Period. Dublin.
- Ware, J 1658 De Hibernia et Antiquitatibus ejus
Disquisitiones. London.
- Ware, J and Harris, W 1739 The whole works of Sir J Ware concerning
Ireland revised and improved by Walter
Harris, II and III. Dublin. 1764, 2nd ed.
- Warner, G F (ed) 1906 and 1915 The Stowe Missal, Henry
Bradshaw Soc, 31 and 32.
- Warren F E 1881 Liturgy and Ritual of the Celtic Church.
Oxford.
- Watson, W J 1929-30 Early Irish influences in Scotland,
Trans Gaelic Soc Inverness, 35, 178-202.
- Webb, J F 1965 Lives of the Saints. London.
- Weitzmann, K 1977 Late Antique and Early Christian Book
Illumination. London.
- Werckmeister, O K 1962-4 Three problems of tradition in
Pre-Carolingian figure-style: from Visigothic
to insular illumination, PRIA, 63c, 167-89.
- Westropp, T J 1907a A Description of the ancient buildings
and crosses at Clonmacnois, King's County,
JRSAI, 37, 277-306.
- Westropp, T J 1907b Descriptive particulars of places
visited, Clonmacnois, JRSAI, 37, 329-40.

- White, T H 1954 The Book of Beasts. London.
- Williams, S de C 1897 The old grave yards in Durrow Parish, JRSAI, 27, 128-49.
- Williams, S de C 1899 The Termon of Durrow, JRSAI, 28, 44-51, 219-32.
- Wilson, D M 1955 An Irish mounting in the National Museum, Copenhagen, Acta Archaeologica, 26, 1-5.
- Wilson, D M 1978 The Dating of Viking art in England in Lang 1978, 135-44.
- Wilson, D M et al 1964 Anglo-Saxon Ornamental Metalwork 700-1100 in the British Museum. London.
- Wilson, D M and Klindt-Jenson, O. 1966 Viking Art. London.
- Wittkower, R 1942 Marvels of the East, a study in the history of monsters, J Warburg Courtauld Inst, 5, 159-97.
- Woodruff, H 1930 The Physiologus of Bern, a survival of Alexandrian style in a ninth century manuscript, Art Bulletin, 12, 226-53.
- Wormald, F 1954 The Miniatures in the Gospels of St Augustine. Cambridge.
- Wright, D (ed) 1967 The Vespasian Psalter, Early English manuscripts in facsimile, 14 Copenhagen, London, Baltimore.
- Zimmerman, E H 1916 Vorkarolingische Miniaturen. Berlin.

CATALOGUE ENTRIES

This catalogue is set out as far as possible in line with that derived for the British Academy Corpus of Anglo-Saxon Stone Sculpture (Cramp forthcoming). Each piece of sculpture is placed alphabetically according to its original find spot or location. Where there is more than one piece from a site these are numbered consecutively using Roman numerals.

Each entry begins with the name of the site and any alternative spellings, the number of the monument and any other names by which it is known, the townland and county in which it is situated, the National Grid Reference, the chapter where it is discussed and the number of the plates.

Each monument is then classified according to type: cross (cross base, cross-shaft, crosshead if fragmentary), shaft, freestanding slab or unknown. Details are given of its present location and any evidence for its discovery including the first time it is mentioned in print.

The main measurements of each monument are given in both centimeters and inches in the following terms:-

- a) The complete height.
- b) For crosses the width of the crosshead. Where only one horizontal crossarm is extant a measurement has been taken from the centre of the crosshead to the end of the surviving horizontal crossarm and multiplied by two.
- c) Three measurements are given for the cross-shaft, shaft and freestanding slab, the height, the width and the depth. On crosses the height includes the butt, if the cross has one, and is measured to the point where the armpit of the cross begins. The width (i.e. the broad faces of the monument) is measured both at the bottom and at the top. The depth (i.e. the narrow faces of the monument) is measured likewise.

d) Similar measurements are given for the cross bases if they are rectangular in section. The height and diameter are given for round bases. If the base only survives the dimensions of the socket are also given.

The stone has then been identified in general terms giving type and, where possible, some indication of colour and coarseness. It has not been possible to have them examined by a geologist. The present condition, degree of weathering, pieces missing, etc. is also noted.

There follows a description of each monument. Any general remarks are followed by a detailed description of each face. A is the principal face, i.e. the west face when the monument is still orientated East/west; otherwise one of the Broad faces. The remaining faces are B, C and D moving anti-clockwise round the monument. A and C are the broad faces; B and D the narrow. The description begins at the top of each face, various panels or motives being indicated with Arabic numerals. Minor measurements are given in centimetres only.

At the end of each entry is the Bibliography.

CLASSIFICATION OF THE MONUMENTS

a) Crosses (Fig. 37)

These are freestanding either set in bases or with the shaft set in the ground.

Some crosses have capstones placed on the top of the crosshead. These may be classified as Roof Shaped, House shaped or Conical (Fig. 38).

The crossheads are classified according to the position of the wheel (Fig. 39).

The cross-shafts are all rectangular in section. Some have a step at the bottom called the butt.

Cross-bases are mostly shaped like a truncated pyramid with one, two or three steps and sometimes rounded corners. Some bases are round.

b) Shafts

These are similar to the shafts of freestanding crosses and are dealt with in a similar way. They do not have butts.

c) Freestanding Slab

There is only one example of this category, Gallen Priory I. It is not classified further.

Fig 37

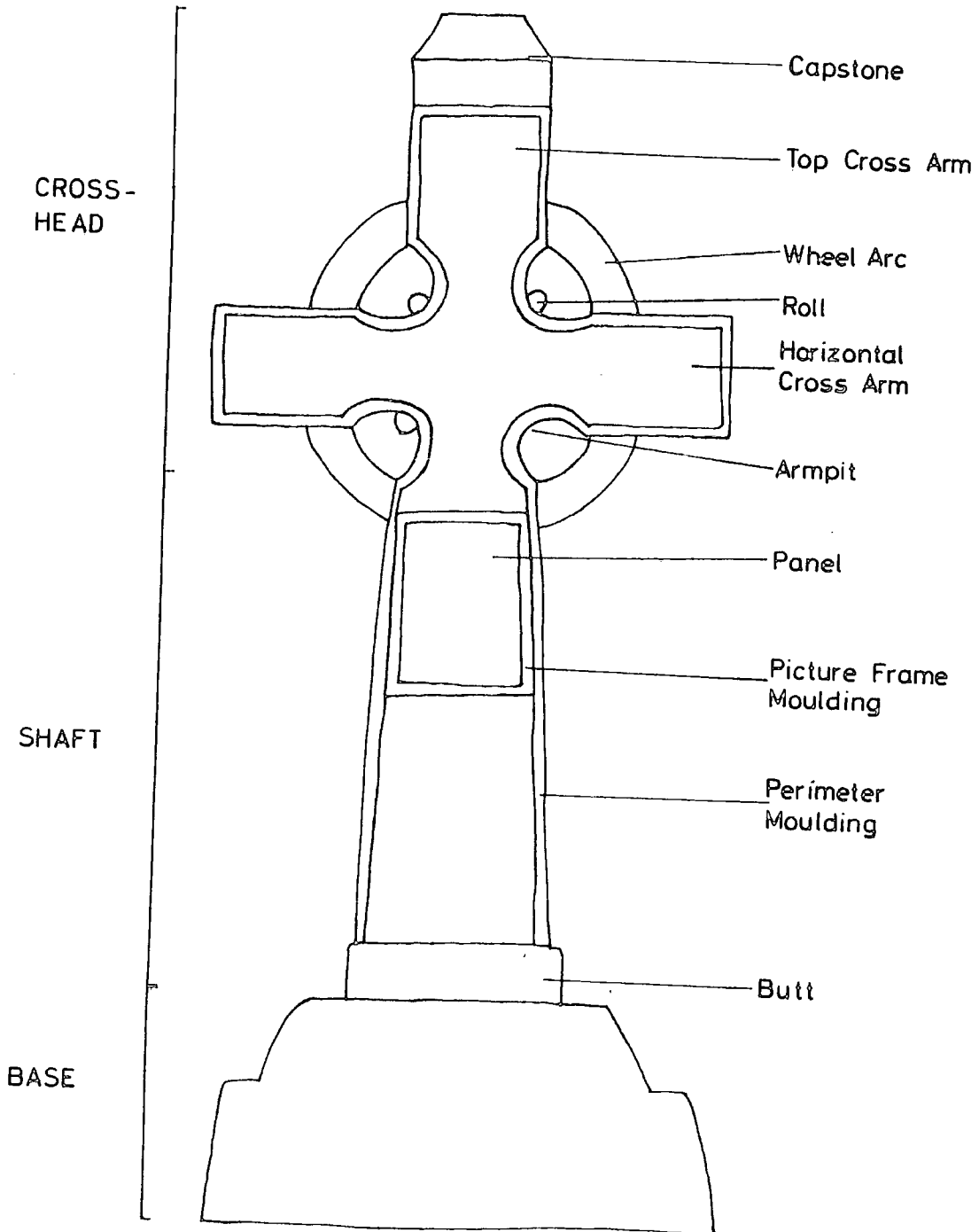

TERMS USED TO DESCRIBE PARTS OF A CROSS

CAPSTONE TYPES

Fig 38

ROOF-SHAPED

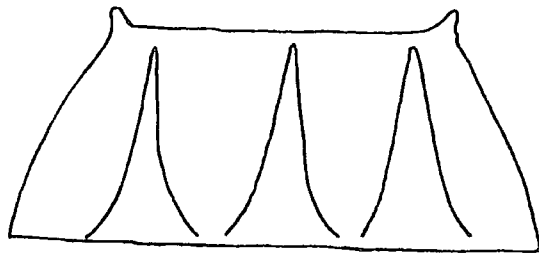

HOUSE-SHAPED

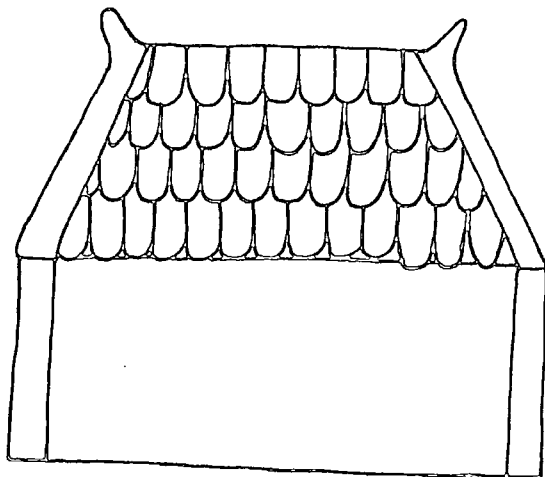

CONICAL

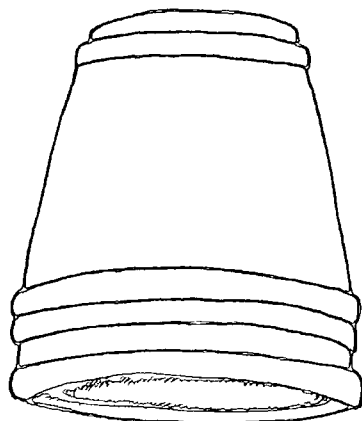

CROSSHEAD TYPES

Fig 39.1

I

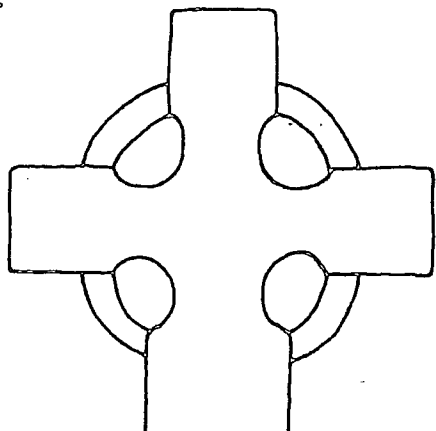

Bealin
Clonmacnoise IV
Killamery
Kilree
Castledermot North
Castledermot South
Moone
Termonfechin

Ia

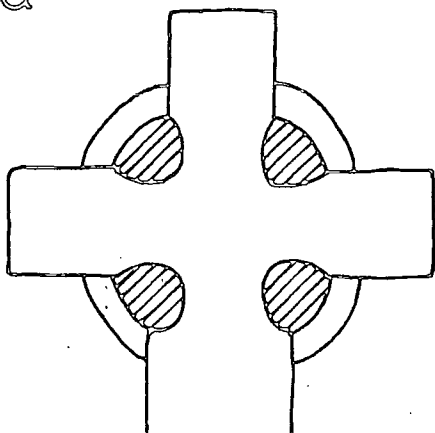

Graiguenamanagh I
Graiguenamanagh II(?)
Ullard
St Mullins

Ib

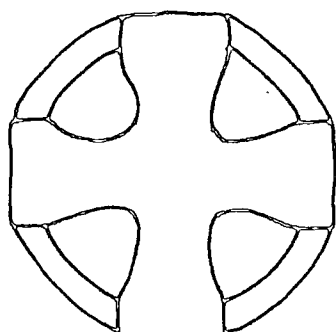

Leggettsrath II(?)

CROSSHEAD TYPES

Fig 39.2

II

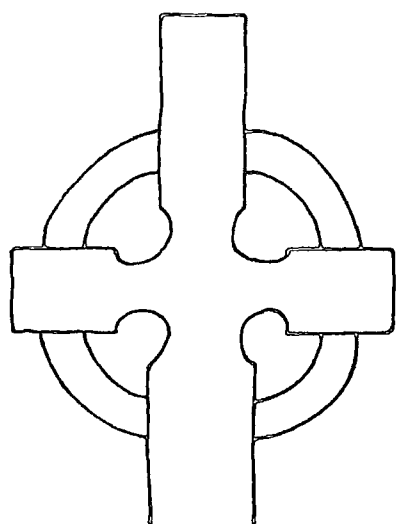

Ahenny I
Ahenny II
Kilkieran II
Kilkieran III

III

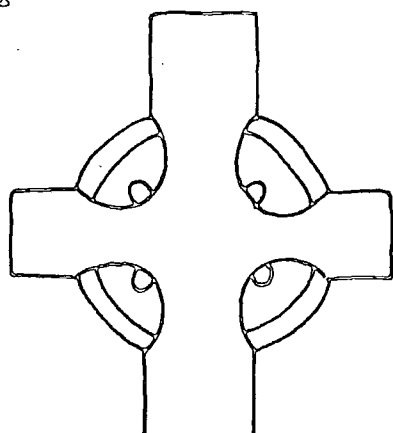

Kells South
Kells Market Cross
Monasterboice South
Monasterboice West
Duleek North (no rolls)

IIIa

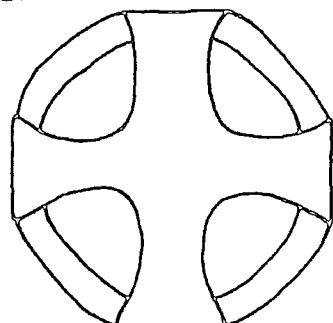

Tihilly

CROSSHEAD TYPES

Fig 39.3

IV

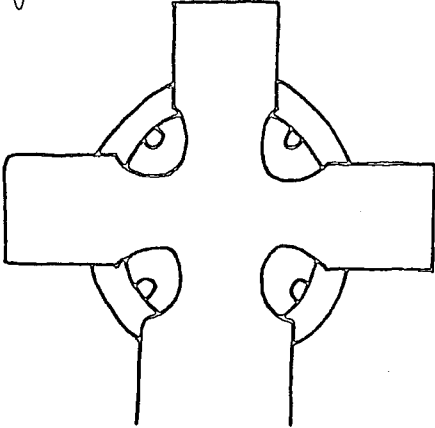

Durrow I
Arboe

V

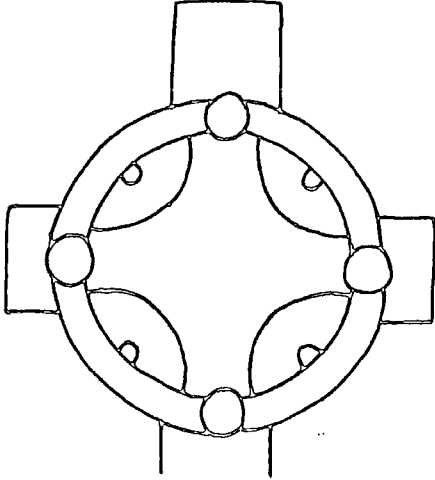

Clonmacnoise V

Va

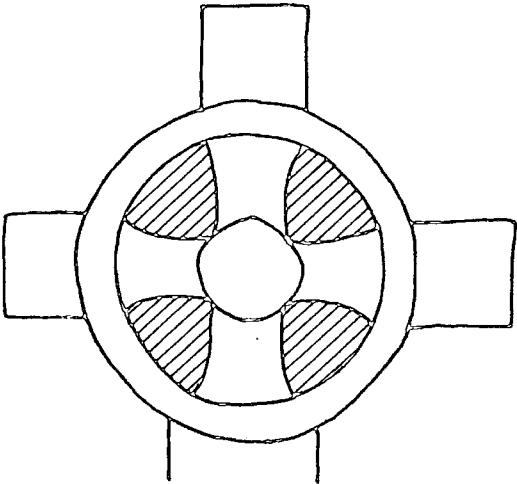

Templeneiry I

CROSSHEAD TYPES

Fig 39.4

VI

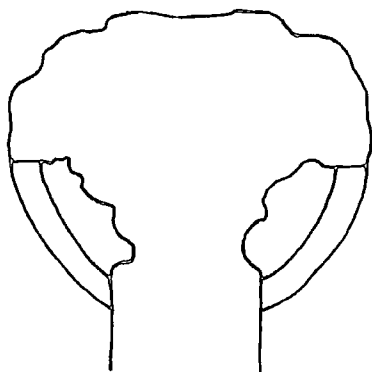

Mona Incha II

VIa

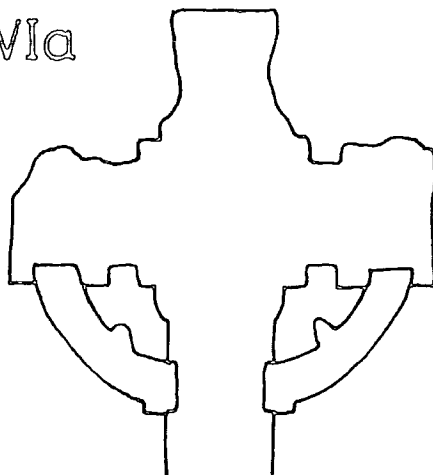

Roscrea II

VII

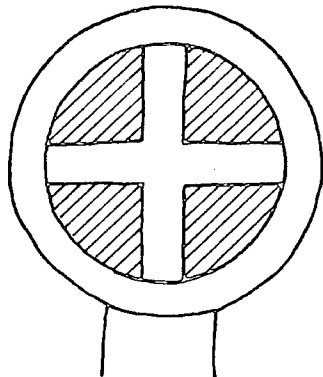

Thomastown

VIII

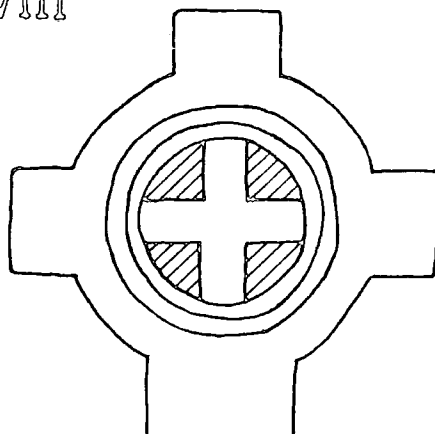

Templeneiry III

MOULDING TYPES

Fig 40

I ROLL MOULDING

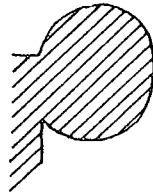

section

IIa ROPE MOULDING

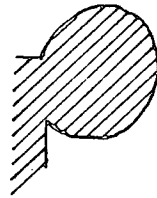

IIb ROPE MOULDING with herring-bone hatching

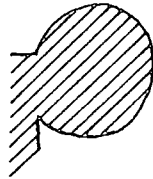

III FLAT MOULDING

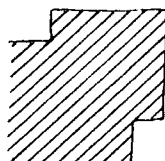
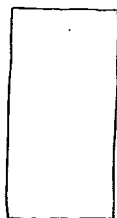

Details of specialised terms used in the ornament are given in Chapter II or the Glossary (Fig. 41). Different moulding types are illustrated in Fig. 40.

GLOSSARY (see also Ch II) Fig 41.1

CONSTRUCTIONAL GRIDS

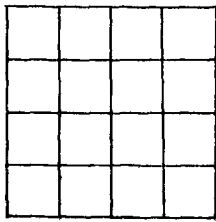

SQUARE GRID

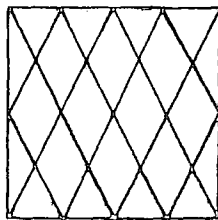
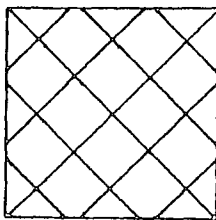

DIAGONAL GRIDS

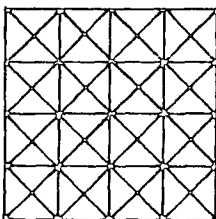

SQUARE AND DIAGONAL GRID

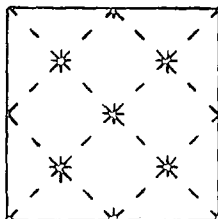
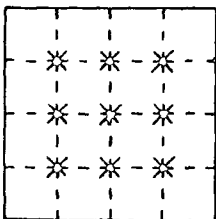

CROSSING POINTS

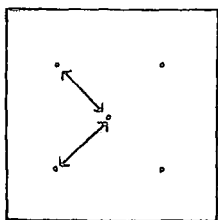
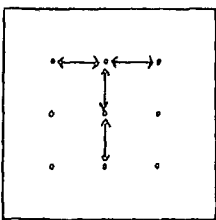

UNIT MEASURE: distance between two adjacent crossing points on a grid.

PATTERN REGISTER



1

2

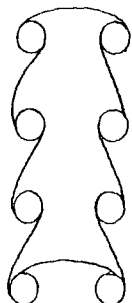

1

2

3

4

INTERLACE TERMS

GRIDS

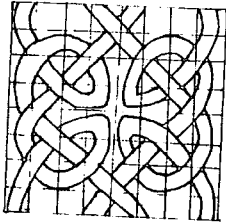

SQUARE GRID

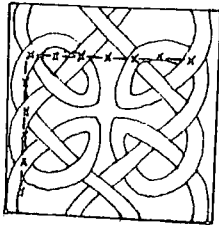

x = CROSSING POINT
 — = UNIT MEASURE

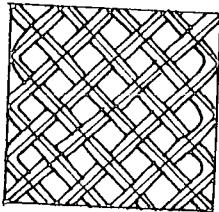

DIAGONAL GRID ON CROSSING POINTS OF PAIRS OF STRANDS

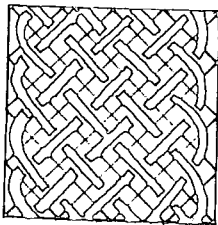

DIAGONAL GRID ON HOLE POINTS

STRANDS

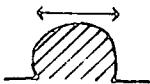

STRAND WIDTH



ROUNDED STRAND All strands are rounded unless otherwise stated.

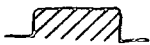

FLAT STRAND



HUMPED STRAND

Fig 41.3

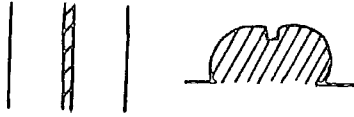

STRAND WITH MEDIAN LINE



STRAND WITH MEDIAN GROOVE

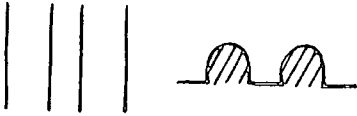

DOUBLE STRAND

OTHER INTERLACE TERMS

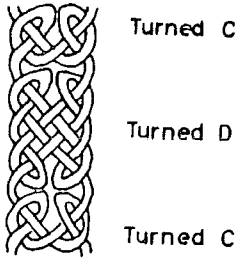

CHANGING PATTERN: a pattern where different interlace elements are combined in a single pattern.

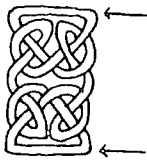

BAR TERMINAL

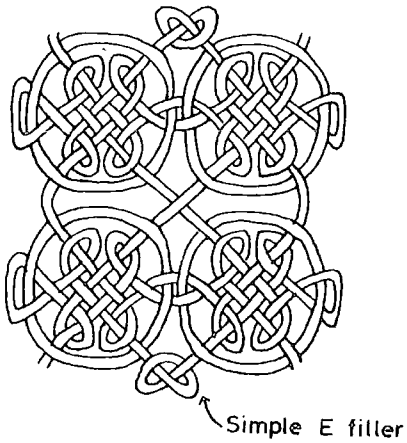

FILLERS: additional elements introduced into main pattern in order to fill spaces.

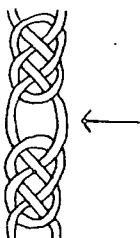

GLIDES: elongated gaps between pattern units.

Fig 41.4

SPIRAL TERMS

EXPANSIONS

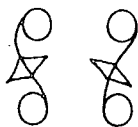
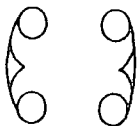

TRIANGULAR EXPANSIONS

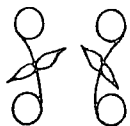

LEAF SHAPED EXPANSIONS

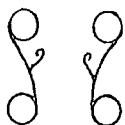

SPIRAL CURLICUES

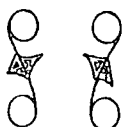

SLASHED EXPANSIONS

OTHER SPIRAL TERMS

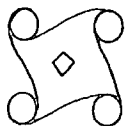

pellet filler

FILLERS: additional elements introduced into main pattern in order to fill spaces.

BOSSES



or



DOMED BOSSES



NAILHEAD BOSS

Abbreviations used in the CatalogueDimensions:

H: Height
W: Width
D: Depth
Diam: Diameter

Constructional Terms:

(see Chapter II and Glossary)

UM: Unit measure
Diag UM: Diagonal unit measure
St W: Strand width

Others:

RA No: Pattern number as in Allen and Anderson
1903, II.
M.G.S: Modern Ground Surface.

AHENNY I (Kilclispeen; North Cross)

Ch. V; Pl. 1

Ahenny, Tipperary

S 413290

Type of Monument: CrossPresent Location: Possibly in situ. Sited in the graveyard of Ahenny some way to the North of a Medieval church.Evidence of Discovery: First mentioned 1857.Measurements:

H:	367 cm (150")
W of crosshead:	137 cm (54")
<u>Shaft:</u>	H: 108.5 cm (42 $\frac{3}{4}$ ") excluding butt
	W: 44 > 38 cm (17 $\frac{1}{4}$ " 15")
	D: 36 > 33 cm (14 $\frac{1}{4}$ " 13")
<u>Base:</u>	H: 67 cm (26 $\frac{1}{4}$ ")
	W: 123 > 71 cm (48 $\frac{1}{2}$ " > 28")
	D: 104 > 55.5cm (41 $\frac{3}{4}$ " > 21 $\frac{3}{4}$ ")

Stone Type: Fine mid-grey sandstonePresent Condition: The cross is complete except for one of the lower wheel arcs and some of the perimeter shaft mouldings. On the whole the carving is well preserved.Description: The crosshead is Type II. It is crowned by a conical capstone. This is decorated with a triple roll moulding round the rim and a further roll moulding near the top. The area between is decorated with traces of plaitwork. The crosshead and shaft have perimeter rope mouldings and the decorated panels are correspondingly recessed. The shaft has a butt. The broad faces of the shaft are divided into panels with horizontal roll mouldings. The base is shaped like a truncated pyramid and has two steps. The panels on the lower step are framed by rope mouldings.Face A

1) The crosshead and upper part of the shaft are decorated as a single unit. There is a nailhead boss at the centre of the crosshead, a domed boss on each of the cross arms and a nailhead boss at the top of the shaft. The surface of the central boss (Diam: 20 > 15 cm) is decorated with a raised cruciform shape with zoomorphic (?) terminals; the side with interlace, Simple F (UM: 2.5 > 1.25 cm; St W: 1 cm). The three domed bosses

(Horizontal cross arm bosses, Diam: 15 cm; top cross arm, Diam: 10 cm) are decorated with interlace, Basic C as a roundel (UM: 2.5 cm; St W: 1 cm). The surface of the boss on the top of the shaft (Diam.: 15 > 10 cm) is decorated with an interlace mesh, the side with interlace, Simple F (UM: 2.5 > 1.25 cm; St W: 1 cm).

The background is decorated with spirals: interlocking 'C' scrolls grouped in fours with 'S' scrolls at the ends of the horizontal cross arms (Various Diam: 5, 7.5, 10, 12.5 cm). A variety of spiral terminals: triple clusters or bird's heads. The smaller spiral terminals are plain. The expansions are slashed with sharp triangular shapes.

The wheelarcs are decorated with fret pattern units each containing a Z element with interlocking half  and triangular auxiliary elements.

2) Anthropomorphic interlace: Four men, each head occupying a corner of the panel. They are shown in profile facing left. Their bodies stretch diagonally across the panel. Their legs, one extended and one flexed, are elongated. Their arms stretch along the sides of the panel, their hands touching or crossing over the hands of adjacent figures. They have short hair and are beardless.

3) Fret pattern: Carpet of Z elements interlocking with  and diamond auxiliary elements. In the centre is an interlace inset, two registers of Simple E with a two strand twist filler in the centre (UM: 1.5 cm; St W: 1 cm).

4) Butt: Three units of step pattern variation. Each unit is divided diagonally into four quarters which have 'L' shapes in the centre angles forming a diagonal cruciform shape. The perimeter of each unit is decorated with triangular cut out shapes.

5) Base: On the top step when viewed from above is a row of square units each decorated with a Cruciform motif, the armpits of which are accentuated by a drilled hole.

6) On the top step: interlace, Simple F units placed vertically side by side and joined top and bottom (UM: 2.5 cm; St W: 1.25 cm). At either end are plaitwork fillers.

7) The lower step has seven figures, the central figure face on and three either side shown in profile facing the centre, one foot raised suggesting motion. The figures have short hair and are beardless. They wear long robes and shorter overgarments which are longer at the back than the front. The figures in profile have high collars and each holds a crozier with a rather flattened hook in his right hand. The central figures has his right arm, possibly holding something, bent across his body while his left arm is straight. His feet point forwards.

Face B

- 1) Crosshead The upper cross arm is divided vertically into three by rope mouldings. The outer panels are undecorated; the central has 6 strand plaitwork.
- 2) The upper wheel arc is faceted forming two long thin rectangular panels. No surviving ornament.
- 3) The panel at the end of the horizontal cross arm is framed by a rope moulding and there is a gap between this and the perimeter moulding. The panel is decorated a combined square panel spiral pattern.
- 4) The lower wheel arc is missing.
- 5) The shaft is decorated with a single border of interlocking 'S' scrolls with leaf shaped expansions slashed with a variety of shapes.
- 6) On the butt is a double border pattern of 'C' scrolls.

Base:

- 7) As A 5
- 8) Upper step: No traces of ornament
- 9) The lower step is decorated with a procession of figures. They have short hair and are beardless and shown in profile moving from right to left. At the head of the procession is a small figure in a long robe and high collar. The figure behind, in a knee length tunic with high collar, holds a processional cross with wheel head. The third figure is dressed similarly and holds a crozier in his right hand; in his left the rein of a horse or donkey. The man carries a burden on his back. A dog with a square head, curly tail and long legs follows behind. The horse or donkey carries a headless body, its legs slung either side of the creature's neck. Two birds, one perched on the beast's head, the second on

the body, appear to peck at the body. The final figure pushes the animal along with his right hand. He is dressed in a knee length tunic with hem border, longer at the back than at the front. He carries another figure on his back.

Face C

1) The crosshead and upper part of the shaft are decorated as a single unit. There is a nailhead boss in the centre of the crosshead (Diam: 18 cm), one on each of the cross arms and one at the top of the shaft. The faces of these are decorated with traces of spirals, the sides with fragmentary fret patterns.

The background is decorated with interlace (UM: 2.5 cm; St W: 1.25 < 1.5 cm). The patterns are mainly plaitwork, 3, 4, 6 and 10 strand according to the width of the field. Other interlace motives are introduced into the basic plaitwork design: Basic C, Half C, Turned C, Basic E, Simple E and Simple F.

The wheel arcs are decorated with spirals, a single border pattern of interlocking 'S' scrolls.

2) Spirals: A combined square panel pattern. The outer 'S' scroll expansions are leaf shaped; the 'C' scroll expansions are triangular and knobbed. They are each slashed with a variety of shapes. The central spiral terminates in a four spiral cluster, each of which has a small triangular cut-out expansion. The outer spirals each terminate in three bird's heads shown in profile.

3) Step pattern variation: 9 units of pattern in three registers of three units. Each unit is divided into four rectangles (5 x 5.5 cm). The perimeter of each unit is formed by 4 'L' shapes, one in each rectangle. In the centre of each unit are four rectangles, again one in each unit. Each pattern unit is outlined in relief.

4) Butt: Spirals, a single border pattern of three spirals joined by 'S' scrolls. The central spiral terminates in a duck-like bird's head; the outer spirals have expanded terminals.

Base:

5) As A 5.

- 6) On the upper step a plaitwork mesh incorporating some breaks in the strands which are rejoined to form loops.
- 7) On the lower step is a figural panel showing a human figure standing by a tree on the left looking at a menagerie of animals. The man is shown in profile facing right. His head, body and arms are long while his legs are rather short. His hair falls to his shoulder and he is beardless. He is dressed in a knee-length tunic. With his right hand he grasps the trunk of a spindly palm tree which stands in front of him. The trunk broadens towards the root and the top breaks into several leafy fronds. To the right are two leonine (?) quadrupeds boxing. They have square gaping jaws, curled snouts, large almond shaped eyes, pointed ears and long curling tails. Above them is an unidentifiable oval area of relief and to the right of this a bird shown in profile facing right with large feet. To the right again are two confronted birds with pointed ears each with one leg raised with a hoop shaped between them. Below is a deer shown in profile moving towards the right. It has short antlers, almond shaped eyes, a short tail, spiral hip joints and cloven hooves. To its right are two other quadrupeds: the first, with a long bushy tail, is shown in profile facing right; the second is placed vertically with its head towards the top of the panel. In the top right hand corner of the panel is a stag with double branched antlers shown in profile facing right. Immediately above and slightly overlapping is a slender hound-like quadruped with a long tail also shown in profile facing right.

Face D

- 1) The top cross arm is divided vertically into three panels by rope mouldings. The outer panels are undecorated. The central panel is decorated with interlace: three registers of Simple E.
- 2) As B 2.
- 3) The Mirror Image of B 3.
- 4) The lower wheel arc is faceted forming two long thin rectangular panels each decorated with a vertical row of Simple F elements (JM: 2.5 cm; St W: 1 cm).
- 5) The Mirror Image of B 5
- 6) As B 6

Base

7) As A 5.

8) The traces of ornament on the upper step are unidentifiable.

9) The lower step is decorated with a procession of horsemen leading a chariot. The procession is shown in profile moving from right to left. The procession is led by a small quadruped (dog?). Behind are two identical horsemen. The horses are in a trotting position, their left legs raised. They have elegant heads, long legs and tails and are harnessed with reins. Their riders have short bodies and legs and wear cloaks with stand up collars. They are beardless. Behind is the chariot drawn by two horses, one shown slightly in front of the other. The chariot shaft is shown above them and above this a second small quadruped. There are two figures in the chariot. The leg of the first figure is stretched in a sitting position. They have shoulder length hair. The chariot is represented by a wheel with eight spokes.

Bibliography

- | | |
|----------------|---|
| O'Neill | 1857, 2, 3, 6; Pl VII |
| Allen | 1887, 229 |
| Carrigan | 1905, IV, 244-5 |
| Power | 1906 |
| Crawford, H.S | 1907a, 208; Pl II |
| Crawford, H.S. | 1909c |
| Champneys | 1910, 72, 82, 92ff; Pl XLI |
| Coffey | 1910, 59; Fig. 56 |
| Stokes, M.M | 1911, 119 |
| Crawford, H.S | 1926a, Nos. 9, 14, 15, 36, 57, 62, 69, 77, 92, 126, 148, 150, 155; Pls I, LI; Figs. 2E, 5A, 7F, 11B. |
| Henry | 1930a, 89 |
| Henry | 1930b, 110, 111 |
| Porter | 1931, 12, 14, 22, 61, 106, 112; Figs. 13, 22, 186, 188 |
| Henry | 1933, 50, 54, 80, 85, 96, 97, 103, 104, 123, 126, 133, 138, 160, 164-5, Figs. 45, 66, 68, 92, 94; Pls 19, 21, 35, 36. |
| Henry | 1940, 102, 103, 104, 105, 106, 108, 111, 117, 147, 175, 192; Figs. 38, 39. |

Henry	1945
Sexton	1946, 7-8, 48-50
Hickey, E	1955
Stevenson	1956, 91-2
De Paor, M & L	1960, 124-6; Fig. 25; Pls 37, 38.
Roe	1962, 13-23
Henry	1964, 22-3, 50-3; Pls 2, 3, 5
Henry	1965, 100, 139-141, 142, 151-3, 155, 156, 207; Pls 79, 80, 83, 88.
Evans	1966, 193
Henry	1967, 143-4
Killanin & Duignan	1967, 143-4
Harbison	1971, 174
Harbison	1975, 219
Harbison	1978, 289, Pls 27, 34
Harbison <u>et al</u>	1978, 57-8
Smyth	1979, 287-8

AHENNY II (Kilclispeen; South Cross)

Ch. V; Pl 2

Ahenny, Tipperary

S 413290

Type of Monument: CrossPresent Location: Possibly in situ. Sited in the graveyard of Ahenny some way to the north of a Medieval church.Evidence of Discovery: First mentioned 1857Measurements:

H:		347 cm (136")
W of crosshead:		135 cm (53")
<u>Shaft:</u>	H:	139 cm (54 $\frac{3}{4}$ ")
	W:	48 > 42 cm (19" > 16 $\frac{1}{2}$ ")
	D:	42.5 > 38 cm (16 $\frac{3}{4}$ " > 15")
<u>Base:</u>	H:	61 cm (24")
	W:	123 > 89 cm (48 $\frac{1}{2}$ " > 35")
	D:	106 > 71 cm (41 $\frac{3}{4}$ " > 28")

Stone Type: Fine mid-grey sandstonePresent Condition: The cross is complete except for part of the capstone (conical?) and some of the perimeter shaft mouldings. The carvings are well preserved except for the base where they are severely weathered.Description: The crosshead is Type II. The crosshead and shaft are surrounded by perimeter rope mouldings and the decorated panels are correspondingly recessed. The panels on faces A and C are separated by incised lines; those on B and D are separated by vertical rope mouldings. At the bottom of the shaft is an undecorated area. The base is shaped like a truncated pyramid and has one step. Each face is divided vertically into two panels. The mouldings are flat and decorated with traces of plaitwork; the central vertical moulding on each face is adorned with a cruciform motif.Face A1) The upper cross arm is decorated with interlace: two registers of adorned Simple E (UM: 5 cm approx; St W: 2.5 cm, median groove).

2) The rest of the crosshead and the upper part of the shaft are decorated as a single unit. There are nailhead bosses at the centre of the crosshead (Diam: 20 > 12.5 cm), on the top cross arm (Diam: 12 cm),

The last has traces of spirals on the face.

The background is decorated with plaitwork (UM: 5 cm approx; St W: 2.5 cm, median groove), four strand plaitwork at the centre of the cross-head, two strand twist round the bosses. At the points where the cross arms broaden out there are pairs of confronted dragonesque heads. The upper jaw of each beast is extended into an interlace strand while the lower is curled upwards into a knob. Each has a large, almond shaped eye and areas of the face are covered with hatching. The necks of the pair on the upper part of the shaft are decorated with spirals.

3) and 4) The upper wheel arcs are decorated with interlace: Simple F.

5) and 6) The lower wheel arcs are decorated with spirals: a single border of 'C' scrolls.

7) Spirals: A combined square panel pattern with hollowed spirals. The 'C' scroll expansions are spiralled while the 'S' scroll expansions are leaf shaped and slashed with a variety of shapes. The spiral terminals expand into shapes reminiscent of foliage.

8) As A.7 except the spirals are of a different size and the 'C' scroll expansions are triangular.

Base

9) and 10) No surviving ornament.

Face B

1) The upper cross arm is divided vertically into three panels with rope mouldings. They are ornamented with interlace: central: Simple E; outer: 2 strand twist.

2) The upper wheel arc is faceted forming two long thin rectangular panels decorated with 2 strand twist (?).

3) At the end of the horizontal cross arm is a spiral panel framed by a rope moulding with a gap between it and the perimeter moulding decorated with hatching. The spirals form a combined square panel pattern with plain triangular expansions.

4) The lower wheel arc is faceted forming two long thin rectangular panels decorated with a crenellated step pattern.

5) The shaft is divided vertically into three panels. The outer two are

decorated with interlace: Simple F elements separated by glides. The central panel has five patterns. Top to bottom they are: (i) Fret pattern: Basic Z elements crossed at right angles with half auxiliary elements, (ii) 6 strand plaitwork (median groove) (iii) As (i); (iv) and (v) Double border patterns of 'C' scrolls in 3 registers.

Base:

- 6) The left panel has traces of unidentifiable carving.
- 7) The right panel shows a hunting scene. At the top is a stag with one antler shown in profile facing left. In the bottom right hand corner is a horseman shown in profile facing left.

Face C

1) The crosshead and the upper part of the shaft are decorated as a single unit. There are nailhead bosses placed in a similar way to A 2. Their faces are decorated with a double perimeter roll moulding and rosettes.

The background is decorated with plaitwork, the broader areas with 4, 6 and 8 strand, and 2 strand twist round the bosses. Parts of the pattern have a median groove.

The wheel arcs are decorated with interlace: Simple E and F.

- 2) As A 7 and 8 except the spirals are not hollowed.

Base

- 3) On the left are traces of Daniel in the Lions' Den, a figure face on in the centre with a quadruped facing him on either side.
- 4) The right panel has traces of unidentifiable carving.

Face D

- 1) As B 1
- 2) As B 2
- 3) As B 3
- 4) The lower wheel arc is faceted forming two long thin rectangular panels decorated with interlace: Simple F.
- 5) The shaft is divided vertically into three panels. The outer panels: as B 5. The central panel has four patterns. Top to bottom they are:

(i) As B 5 (iv); (iii) As B 5 (i); (iii) 6 strand plaitwork (Diag UM: 5 cm; St W: 1.5 cm); (iv) Combined double border pattern of spirals.

Base:

Both panels are now badly weathered but using old photographs (Crawford H.S., 1926a, No. 153) hunting scenes may be seen.

6) On the left are two bears with gaping jaws shown in profile facing left placed one above the other. There are traces of spiral hip joints on the lower beast. To the left is a quadruped placed vertically shown in profile, head downwards. At the bottom of the panel is a horseman shown in profile facing left followed by a hound, also in profile.

7) On the right at the top are deer like quadrupeds shown in profile. Below are two horsemen, one behind the other facing left.

Bibliography

- | | |
|--------------------|--|
| O'Neill | 1857, 2, 3; P1 V |
| Carrigan | 1905, IV, 244-5 |
| Power | 1906 |
| Crawford, H.S | 1907a, 208 |
| Crawford, H.S | 1909c, 258-60 |
| Champneys | 1910, P1 XL |
| Crawford, H.S | 1926a, Nos. 34, 153; P1 II; Figs 2D, 3A, 4A 7E, 9D. |
| Henry | 1930a, 95, 96, 102. |
| Henry | 1930b, 110, 111. |
| Porter | 1931, 22, 61, 106, 112; Fig. 187 |
| Henry | 1933, 50, 54, 80, 85, 96, 97, 100, 133, 134, 160, 164-5; P1s 19, 20, 27, 34, 35, 37. |
| Henry | 1940, 102, 103, 104, 111, 117, 175, 192 |
| Sexton | 1946, 7-8, 51-2 |
| De Paor, M & L | 1960, 124-6, P1 36 |
| Roe | 1962, 23-30 |
| Henry | 1964, 21-4; P1 4 |
| Henry | 1965, 139-141, 142, 147, 155, 156, 207; P1s 76, 77. |
| Evans | 1966, 193 |
| Killanin & Duignan | 1967, 143-5 |
| Harbison | 1975, 219 |
| Smyth | 1979, 287-8 |

AHENNY III (Kilclispeen)

Ch. V: P1 3

Ahenny, Tipperary

S 413290

Type of Monument: BasePresent Location: Sited in the graveyard at Ahenny some way to the North of a Medieval church.Evidence of Discovery: First mentioned 1905.Measurements:

H: 42cm (16½")

W: 63 > 32 cm (25" > 12½")

D: 60 > 40 cm (25¼" > 15¾")

Socket: W: 28 cm (11")

D: 23 cm (9")

H: 19 cm (7½")

Stone Type: Fine mid-grey sandstone.Present Condition: Face B is badly damaged.Description: The base is shaped like a truncated pyramid. It is undecorated but has been dressed.Bibliography

Carrigan	1905, IV, 245
Power	1906, 10
Crawford, H.S.	1907a, 208
Killanin & Duignan	1967, 143

BANAGHER (Kill-Regnaighe)

Ch. IV: Pl 4

Banagher, Offaly

Type of Monument: ShaftPresent Location: National Museum of Ireland, Dublin.

Evidence of Discovery: First mentioned 1853. Before that it had once stood by a spring in the Market Square adjacent to the Churchyard at Banagher. In 1853 it was 'prostrate on the earth'. In 1896 it was at Clonmacnoise but in 1929 it was moved to the National Museum.

Measurements:

H:	148 cm (57")
W:	39 > 34.5 cm (16" > 14 $\frac{1}{4}$ ")
D:	17 cm (6 $\frac{3}{4}$ ")

Stone Type: Dark red sandstone

Present Condition: The shaft has been broken at the bottom and some of it is therefore missing. Shallow rectangular slots have been cut out of both B 1 and D 1. The carving, apart from areas of Face A, is well preserved.

Description: At the top of the shaft in the centre is a mortice hole (W: 7cm; D: 3.5 cm; H: 1.5 cm). The shaft has perimeter roll mouldings and is divided into panels framed by roll mouldings.

Face A

1) At the top of the panel is a lion shown in profile facing right, its left legs raised in motion. Its head is large with a pointed ear, large almond shaped eye, rather square jaws outlined by an incised line and a lolling tongue. Its snout terminates in a rounded knob. It has prominent paws, a floriate tail terminating in leaf shaped tufts arches over its back and traces of a curly mane at the base of the spine.

Below is a horseman shown in profile facing right, the horse's left legs raised in motion. The horse has a long tail. Its mane is carved with vertical incised lines and both ears are indicated. The horseman holds the rein in his right hand. He is a squat figure dressed in a bordered garment which wraps round his right arm, his hair curling down his back. A crozier rests on his left shoulder.

2) A stag is shown in profile facing right, its left legs raised in motion. Its right foreleg is caught in a rectangular frame. Its head is slightly

raised with a long, thin snout, lolling tongue and two branched antlers.

3) Anthropomorphic interlace: The lower part of the panel is missing. The surviving area shows two figures placed diagonally across the panel, their heads placed in the top two corners with the fragmentary remains of two similar figures below. They are shown in profile facing right. They have long beards and long hair, the strands of which curl round their wrists and are then grasped in the hands of adjacent figures. Their legs, one flexed and one extended, interlace in the centre of the panel forming a cruciform cut out shape.

Face B

1) The panel is damaged but the surviving area contains figure of eight interlace terminating in a forked fish tail (UM: 2 cm; St-W: 1.25 cm).

2) Spirals: Combined double border pattern in three registers. The 'S' scroll expansions are leaf shaped and the 'C' scroll expansions are triangular.

3) Interlace: Turned D, four elements abreast in four registers (UM: 1 cm; St W: .75 cm).

4) Zoomorphic Interlace: incomplete. A procession of birds with spiralled bodies. $2\frac{1}{2}$ pattern units survive. Each bird stretches over 2 registers. The bird's head, neck and front leg form the diagonal across the spiral. The bird has a crest which curls round its neck. The neck broadens out to form a triangular wing on the left of the panel and then forms a muddled spiral beneath.

Face C

1) Interlace: Basic A, 3 elements abreast in 3 registers (UM: 3 cm; St W: 2.5 < 3cm, median line).

2) A lion shown in profile facing right, its body arched. It has a rounded ear, knobbed snout and traces of a curly mane run the length of its back. The tail and lolling tongue have become extended into interlace strands which fill the spaces round the beast; they form a Simple F element behind its head.

3) At the top anthropomorphic interlace, a single register of Turned D (UM: 3 cm; St W: 2.5 < 3 cm, double strand with median line) terminating

at the top in two confronted men. Their heads have flat tops and they have long thin faces and pointed chins. They are beardless but their forelocks are extended into a Simple F element, the loose strands being caught in the clenched fists of the right man. The man on the left holds the other by the wrists.

Below is the fragmentary remains of a second motif consisting of a single bird's head facing left with a prominent beak, large almond shaped eye and a crest which has been extended into a Simple F element. There are traces of other interlace strands to either side of its head.

Face D

1) The upper part of the panel is damaged but the surviving interlace is probably a changing pattern combining 12 strand plaitwork with Simple E and F elements (UM: 1 cm; St W: .75 cm). Four strands remain loose, two terminating in confronted bird's heads, each catching another loose strand in its beak.

2) Spirals: As B 2 in 4 registers.

3) Interlace: At the top Encircled E in 3 registers of a single unit (UM: 1.5 cm; St W: .75 cm) with zoomorphic terminals top and bottom. In each case one strand terminates in a bird's head with crest with a second strand in its beak.

Below Turned C with outside strands (UM: 2 cm; St W: 1.25 cm). 2½ registers survive.

Bibliography:

Cooke	1853, 277-80; Pl 44.
Keane	1867, 174, 176
Graves	1871
Allen	1896-7, 309-14.
?Crawford, H.S.	1907a, 224 (East Cross).
Macalister	1909, 154
Gillespie	1918-19
Crawford, H.S.	1927, 2
Macalister	1928, 194; Fig. 11d
Henry	1930a, 96
Henry	1930b, 111
Henry	1933, 53, 66, 85, 97, 98, 117, 123, 138, 165; Figs. 19, 45, 60; Pls 38, 39.

Henry 1940, 106, 117, 148
Sexton 1946, 65-6.
Stevenson 1956, 91
De Paor, M & L 1960, 90, 144
Henry 1964, 24-5
Henry 1965, 100, 143, 145, 199; Pls 92, 93, 94.
Ryan 1973, 64.
Harbison et al 1978, 58; P1 42.
Hicks 1980

BEALIN

Ch. IV; Pl 5

Twyford, Westmeath

N 420100

Type of Monument: CrossPresent Location: In a field to the West of Bealin village.Evidence of Discovery: First mentioned 1907.Measurements:

H: 202 cm (81")
 W of crosshead: 102 cm (40") approx.

Shaft

W: 33 < 34 cm (13" < 13½")
 D: 26.5 > 25 cm (10½" > 9¾")

Stone Type: Rough, pale grey limestone with grit inclusions.Present Condition: Three wheel arcs are missing and the carving is severely weathered being totally lost in some areas.Description: The crosshead is Type I. The monument has perimeter roll mouldings and the shaft is divided into panels by horizontal roll mouldings.Face A

1) Crosshead: In the centre is a flat interlace roundel surrounded by a roll moulding. In the middle is Basic C adapted as a roundel (UM: 1.5 cm; St W: .75 < 1 cm) enclosed by a roll moulding and round this Simple F.

On the right hand horizontal cross arm is another Basic C interlace roundel (UM: 1.5 cm; St W: .75 < 1 cm) surrounded by 2 strand twist (UM: 6 cm approx; St W: 1.5 cm). The left hand horizontal cross arm is weathered but the decoration is likely to be similar. There is no surviving ornament on the upper cross arm.

Shaft:

2) 6 strand plaitwork (UM: 6 cm; St W: 3.5 cm, median groove). Two of the strands have been extended either side of another Basic C roundel terminating in a pair of confronted beasts with long interlocking beaks. The interlace strand, still retaining the median groove, widens to form the beasts' body, a paw-like appendage projecting from the top of the side facing inwards. Each beast has a large, elongated eye, a

double incised line separating its head from its body, a third line separating its beak from its head and a small, pointed cat-like ear.

3) Interlace: Encircled and Turned E, 2 registers of 2 units (UM: 3 cm; St W: 1.5 cm).

4) Inscription in relief:

OROIT AR TUATHGAIL LAS DERNATH IN CHROSSA

Face B

The motives on this face are not separated by horizontal roll mouldings.

Crosshead: No surviving ornament

Shaft:

1) Interlace: Basic E in 2 registers (UM: 3 cm; St W: 1.5 < 2 cm).

2) Step Pattern: Single unit of triple step pattern with 4 auxillary L elements, one in each corner.

3) Hunting Scene: At the top is a stag shown in profile facing right its left legs raised in motion. Its head is slightly raised. It has two many branched antlers and a lolling tongue. Below is a thin hound with a long curling tail shown in profile facing left. It grasps the stag's right hind leg in its jaws. Below again is a horseman shown in profile facing right, the horse's left legs raised in motion. It has a long tail and a rein stretches from its mouth across its neck. The man has a stubby body and short legs. He holds a spear in his right hand which rests on his shoulder. His long hair is divided into 2 strands, the first stretching the length of his back, the other curling behind his head. He has a prominent nose and a large almond shaped eye. The space behind the horseman is filled with a triquetra knot.

Face C

Crosshead:

1) In the centre is a square panel framed by a roll moulding decorated with interlace, Basic C (UM: 3 cm; St W: 2 cm, median groove).

2) On the upper cross arm is a double triquetra knot (St W: 1.5 cm).

3) On the left hand horizontal cross arm is a beaked quadruped. It

is shown in profile facing left, its right legs raised in motion. It has prominent paws. Its body is arched and traces of a curly mane run the length of its body. Its long tail with long leaf shaped tufts curls downwards before arching up to stretch along its back and the rounded tip is caught in the animal's beak. Its beak is large and slightly hooked. It has a large, almond shaped eye and a slight ear ridge.

There is no surviving ornament on the right hand horizontal cross arm.

4) Shaft: The entire length is decorated with zoomorphic interlace, a procession of three birds with spiralled bodies with a lion at the bottom. The bird at the top is incomplete but the other 2 each stretch over 2 spiral registers. Each complete bird consists of its neck and one leg forming the diagonals across a spiral, its head with a long slightly hooked beak and curling crest stretching beyond the spiral. Between the spirals the body expands on the left to form a wing which is slashed and decorated with feathery curls. The bird's body then forms a spiral coil, forming two legs at the centre. The bird at the top has no wing. The lion's tail forms the diagonal across the lowest spiral and terminates in 4 leafy tufts. It is shown in profile facing left, its right legs raised in motion. It has a squashed face, rounded ear, fleshy lips, lolling tongue and its snout is curled.

Face D

Crosshead: The upper wheel arc is missing.

- 1) The panel at the end of the horizontal cross arm is decorated with interlace, a single unit of Half B with bar terminals top and bottom (UM: 3 cm; St W: 3 cm, median groove).
- 2) On the lower wheel arc, Half B in 5 registers (UM: 1.5 cm; St. W: .75 cm).

Shaft

- 3) Interlace: Basic A in 3 registers (UM: 3 cm; St W: 1.5 cm).
- 4) Spirals: combined double border pattern, 2 registers. The 'S' scroll expansions are leaf shaped, the 'C' triangular and both are slashed.

5) Zoomorphic Interlace: An interlocking figure of eight interlace, the top terminating in a serpent's head which turns to bite its own body, the bottom in a slashed fish tail.

Bibliography

- | | |
|-----------------------|--|
| Crawford, H.S. | 1907a, 232 |
| Crawford, H.S. | 1907b |
| Champneys | 1910, 72 |
| Crawford, H.S. | 1926a, Nos. 16, 38, 39, 67, 79, 91, 156; Fig. 6c. |
| Crawford, H.S. | 1927, 2-4, Fig. 8; Pl XII. |
| Henry | 1930a, 96, 100, 102 |
| Henry | 1930b |
| Porter | 1931, 10 |
| Gougaud | 1932, 350 |
| Henry | 1933, 16, 17, 20, 53, 66, 80, 82, 97, 98, 104, 117, 160, 165; Figs 42, 66; Pls 40, 51. |
| Henry | 1940, 85, 106, 113, 148; Fig. 40. |
| Sexton | 1946, 68-9 |
| Macalister | 1949, Pl 5, No. 871 |
| Stevenson | 1956, 91 |
| de Paor, M & L | 1960, 144, 146; Fig. 40 |
| Roe | 1962, 9-10. |
| Henry | 1964, 18, 24-5. |
| Henry | 1965, 139, 141, 143, 144, 146, 154, 155, 156, 158; Figs. 18, 25; Pl 88. |
| Killanin & Duignan | 1967, 77 |
| Ryan | 1973, 64 |
| Harbison | 1975, 241 |
| Harbison <u>et al</u> | 1978, 58. |
| Hicks | 1980 |

CASHEL (St. Patrick's Cross)
St. Patrick's Rock, Tipperary

Ch. I, Pl. 6.
S 126408

Type of Monument: Cross

Present Location: Probably in situ. The cross is situated on the Rock of Cashel near the S.W. corner of the Cathedral and on the same alignment as Cormac's Chapel.

Evidence of Discovery: First mentioned in 1841 by the Ordnance Survey (O'Donovan 1928a).

Measurements:

H:	215 cm (84½")
Original W of crosshead:	92 cm approx (36¼") reconstructed
<u>Shaft:</u> H:	146 cm (57½")
W:	42 > 40 cm approx. (16½" > 15¾")
D:	22 < 23 cm (8¾" < 9")
<u>'Crutch':</u> H:	146 cm (57½")
W:	6 cm (2¼")
D:	21 cm (8¼")
<u>Base:</u> H:	112 cm (44")
W:	145 > x 114 cm (57" > 44¾")
D:	108 > 77 cm (42½" > 30¼")

Stone Type: Fine yellowish grey sandstone of poor quality.

Present Condition : One horizontal cross arm and 'crutch' are missing. The heads of the figures on faces A and C are missing. The carving is badly weathered.

Description: The crosshead (Unclassified) is without a wheel with rolls placed in the rounded angles of the lower armpits only. The upper cross arm is very broad. At the junction between it and the horizontal cross arm on Face B is a mortice (W: 10.5 cm; D: 5 cm; H: 23 cm). Immediately below this is a hole (3.75 cm x 3.75 cm). There is a corresponding hole on Face D where it is continued as a groove onto the upper surface of the cross arm.

The shaft is rectangular in section. The remaining horizontal cross arm is supported by a 'crutch', a vertical pillar, rectangular in section, which rises from a transom at the base of the shaft. There is a further transom linking cross shaft and 'crutch' about half way

up the monument.

The massive base is approximately rectangular tapering slightly towards the top. It has a shallow upper step.

Face A

There are traces of perimeter roll mouldings on the right hand side of the shaft, round the right armpit and on the 'crutch'.

1) The crosshead and shaft are decorated with the single figure of Christ Crucified in high relief. He stands face on, His elongated body erect. His head, right arm and left hand are missing. His feet point downwards supported on a fluted suppedaneum. He is clad in an ankle length sleeved robe with a raised hem border. Above the hips it is tied with a knotted belt, the ties of which hang downwards.

2) Base: No surviving ornament.

Face B

1) 'Crutch': There are traces of flat mouldings which define 2 rectangular panels with semi circular concave ends. 19 cm up from the bottom of the 'crutch' is a hole (H: 4 cm; W: 5cm; D: 2cm). Otherwise the crosshead, shaft and 'crutch' are undecorated.

2) Base: The upper step is undecorated. On the lower is a step pattern: 2 registers of single step units with cruciform shapes in the centre all outlined in relief (UM: 5 cm approx).

Face C

1) The crosshead and shaft are decorated with a single figure in high relief. He is face on and now headless. The right arm is raised and the left hand holds a crozier. He is clad in an alb, chasuble and possibly a cloak. There are traces of drapery folds round the neck. His pointed feet are supported on a suppedaneum ornamented with a beast's head shown face on. The beast has small triangular pointed ears, huge eyes outlined in relief and a prominent snout.

2) Base: The upper step is undecorated. The lower is decorated with zoomorphic interlace set on the diagonal. Two adored birds with crests may be seen on the upper part of the panel.

Face D

- 1) The shaft is outlined with perimeter roll mouldings.
- 2) Base: The upper step is undecorated. In the centre of the lower step is a quadruped, shown in profile facing right, its head turned towards its tail surrounded by a large hairspring spiral.

Bibliography

- | | |
|-----------------------|--|
| Petrie | 1845, 272, 306. |
| Crawford, H.S. | 1907a, 207 |
| Champneys | 1910, 97 |
| Macalister | 1928, 327 |
| O'Donovan | 1928a, I, 311 |
| Henry | 1933, 104, 137, 161; Pl 108. |
| Sexton | 1946, 87-8 |
| Leask | 1951 |
| Henry | 1964, 33; Pl. 64 |
| Evans | 1966, 194 |
| Killanin & Duignan | 1967, 148. |
| Henry | 1970, 125, 127, 128-9, 130, 132, 139; Pls 61, 62 |
| Farnes | 1975 |
| Harbison | 1975, 223 |
| Harbison <u>et al</u> | 1978, 66. |

CLONMACNOISE I (Clonmacnois, North Shaft)

Ch. IV, Pl 7.

Clonmacnoise, Offaly

NO10307

Type of Monument: ShaftPresent Location: Sited in the grounds of the modern enclosure at Clonmacnoise to the North of the Cathedral.Evidence of Discovery: First recorded 1658.Measurements:

H: 186 cm (74½")

W: 40 > 37 cm (15¾" > 14½")

D: 32 cm (12½")

Stone Type: Yellow ochre limestone with large grit inclusions.Present Condition: Badly weatheredDescription: The shaft is complete. It has a tenon at the top (W: 18 cm; D: 18 cm; H: 5 cm) and perimeter roll mouldings.Face A

This face is divided into 5 panels framed by roll mouldings. The lower 4 are of approximately equal size. All are decorated with interlace.

- 1) 2 square panels placed side by side with curved roll mouldings across the corners. Each contains a flat roundel with Basic C as a roundel (UM: 1.5 cm; St W: 1.5 cm).
- 2) There are curved roll mouldings across the corners of the panel Spiralled and Surrounded C in 2 registers (UM: 1.5 cm; St W: 1.5 cm).
- 3) Basic C, 4 elements abreast and in 2 registers with a row of 2 strand twist in the centre (UM: 2 cm; St W: 1.5 cm).
- 4) Spiralled and Surrounded A in 2 registers (UM: 2 cm; St W: 1.5cm).
- 5) Encircled and Turned E in 2 registers of 2 units (UM: 1.5 cm; St W: 1.5 cm).

Face B

- 1) On the upper part of the shaft there are 3 motives. The upper end of the first is missing making identification impossible but a

central band decorated with incised 'C' scrolls with a mass of intertwining strands below does survive.

Below is a griffin-like biped shown in profile facing left with its head turned backwards to grasp its long floriate tail in its beak. It has a large almond shaped eye with raised iris and drilled pupil, a small pointed ear and an incised line runs down its face parallel with the line of the beak.

Below again is a quadruped with a duck-like head and body shown in profile facing right, its head facing its tail. The head has a crest and a round eye with drilled pupil. Its legs are shown in motion and have hooves.

2) Two confronted quadrupeds, their upper limbs and necks interlaced, their bodies and lower limbs curled round and interlocking with each other. They have thin bird-like heads with long pointed ears, large almond shaped eyes with drilled pupils and large beaks.

3) Changing interlace: Turned B and Turned C with a bar terminal at the bottom (UM: 3 cm; St W: 3 cm, median line).

Face C

Undecorated.

Face D

This face is divided into 4 panels framed by roll mouldings.

1) A lion shown in profile facing right, its left foreleg raised in motion. Its tail curls upwards parallel with the line of its back, dividing into four branches which terminate in leaf-shaped tufts. The head is small with a rounded snout, a long pointed ear, a large almond shaped eye with raised iris and drilled pupil, fleshy jaws and a lolling tongue.

2) A single vertical 'S' scroll. Each spiral terminates in a bird's head shown in profile facing right. It clasps a strand in its long hooked beak. It has a large almond shaped eye with a raised iris and drilled pupil.

3) Anthropomorphic motif: A figure shown face on seated cross legged with its arms crossed in front of its body. The face has large staring eyes, the irises in relief, the pupils drilled. There are traces of

strands either side of the head.

4) Zoomorphic interlace: Very weathered. Possibly a changing interlace pattern, a surrounded E element at the bottom (?), with 2 adored bird's head terminals at the top. They have crests and large almond shaped eyes.

Bibliography

Ware	1658, 304
Ware & Harris	1739, II, 46
Allen	1896-7, 312
Crawford, H.S.	1907a, 225
Westropp	1907a, 297
Westropp	1907b, 334
Crawford, H.S.	1910, 356
Henry	1933, 123; Pl 41
Henry	1940, 106, 108
Sexton	1946, 101-2
De Paor, M & L	1960, 144
Henry	1964, 24-5; Pl 10
Henry	1965, 114, 143, 144, 146, 155; Pl 91
Evans	1966, 181
Killanin & Duignan	1967, 171
Ross	1967, 147
Ryan	1973, 64
Harbison	1975, 203
Hicks	1980

CLONMACNOISE II (Clonmacnois)

Ch IV; Pl 8

Clonmacnoise, Offaly

NO10307

Type of Monument: ShaftPresent Location: National Museum of Ireland, Dublin.Evidence of Discovery: None. According to National Museum records it was acquired in 1929 and brought there from Clonmacnoise.Measurements:

H: 92.5 cm approx. (37")

W: 37 cm (14 $\frac{3}{4}$ ")

D: 18 cm (7")

Stone Type: Yellowish sandstone.Present Condition: The shaft now consists of 2 adjoining pieces. The carving is weathered and the face of the stone is badly damaged in places.Description: There is a tenon at the bottom of the shaft (W: 31 cm; D: 14.5 cm; H: 7 cm). The shaft has perimeter roll mouldings and each panel is framed by a roll moulding.Face A

1) Spirals: a combined double border pattern in 3 registers. A short vertical 'stalk' with a projecting blade at either side joins the final register to the bottom of the panel. The outer 'S' scroll expansions are leaf shaped and terminate in a circular knob, curling over the line of the 'S' scroll. The inner 'S' scroll expansions interlace to form a triquetra knot. The 'C' scroll expansions are half circular, slashed and knobbed. The spiral terminals are expanded into knobs and slashed.

Face B

1) There are 3 motives placed one above the other in a single panel. The first is a Double step pattern in 2 registers (UM: 1.5 cm). Each unit has a cruciform centre.

Below Interlace: Turned C in 3 registers with bar terminal top and bottom (UM: 3 cm; St W: .75 < 1 cm).

The third motif is identical to the first except the cruciform centres are punched out rather than incised.

Face C

Undecorated.

Face D

1) Changing interlace: 6 strand plaitwork; then Turned E in $2\frac{1}{2}$ registers (UM: $2 < 2.5$ cm; St W: 1.5 cm).

Bibliography

Henry 1940, 106.

CLONMACNOISE III (Clonmacnois)

Ch IV; Pl 9

Clonmacnoise, Offaly

NO10307

Type of Monument: ShaftPresent Location: Exhibited amongst the grave slabs in the grounds of Clonmacnoise.Evidence of Discovery: The upper fragment is first mentioned 1896-7. In 1909 it was in Temple Doolin. It is not clear when the adjoining fragment was found. It is first illustrated in 1960.Measurements:

H: 91.5 cm approx (37")

W: 38 cm (15")

D: 18 cm (7")

Stone Type: Yellowish sandstone.Present Condition: The shaft now consists of 2 adjoining pieces. The carving is weathered and much of it on faces B and D has been completely destroyed. It is embedded in concrete.Description: The shaft has perimeter roll mouldings and each panel is framed by a roll moulding.Face A

1) A single panel containing 4 motives. At the top is a lion-like quadruped shown in profile facing right, its left legs raised in motion. It has large paws. Its body is arched and its back is draped with a curly mane. Its tail loops downwards and then curls upwards behind its head dividing into 4 branches which terminate in leaf shaped tufts. On its head is a low crest or ears. It has a large almond shaped eye with drilled pupil. Its large fleshy jaws, which are separated from its face by an incised line, are closed.

Below is a similar quadruped in an identical stance except that its head is turned to grasp the upper beast's right front leg in its jaws. It has a small round ear and there is no trace of an eye.

The third motif is a horseman shown in profile facing left, the horse's right legs raised in motion. The horse has a long tail. The rein is caught in the left hand of the rider, a foreshortened figure. The top of his head is flat and his hair curls down to his shoulder.

At the bottom is another quadruped shown in profile facing right, its head turned to grasp its floriate tail in its fleshy jaws. Its body is slender, its legs squashed. It has a small head with an almond shaped eye and curly mane, further traces of which may be seen the length of its back.

Face B

1) Interlace: badly damaged. A single register of Turned C with a bar terminal at the top (UM: 2 cm; St W: 2 cm). On the lower part a changing pattern: Closed Circuit F, 6 strand plaitwork and a single unit of Basic B with a bar terminal (UM: 3 cm; St W: 3cm).

Face C

Undecorated.

Face D

1) Interlace: badly damaged. On the upper half of the shaft is Turned D (UM: 2.5 cm; St W: 1.5 cm, humped strand with median groove).

Bibliography

Allen	1896-7, 312; Fig. 2
Macalister	1909, 154
Henry	1930a, 96, 100, 102
Henry	1933, 117, 165; Pl. 38
Henry	1940, 106
Sexton	1946, 102
De Paor, M & L	1960, 144; Pl 54
Henry	1964; Pl 11
Henry	1965, 144; Pl 95.
Hicks	1980

CLONMACNOISE IV (Clonmacnois, South Cross)

Ch. IV, P1 10

Clonmacnoise, Offaly.

NO10307

Type of Monument: CrossPresent Location: Probably in situ. It is standing in the grounds of Clonmacnoise 1.6 m South West of Temple Doolin.Evidence of Discovery: First recorded 1658.Measurements:

H:	376 cm (146")
W of crosshead:	130 cm (52")
<u>Shaft:</u>	H: 167 cm (67")
	W: 46 > 45 cm (18" > 17¾")
	D: 31 < 33 cm (12" < 13")
<u>Base:</u>	H: 85.5 cm (33½")
	W: 119 > 88 cm (48" > 34½")
	D: 88.5 > 51 cm (35" > 20")

Stone Type: Yellowish sandstone.Present Condition: The carving is weathered, especially on the Base.Description: The crosshead is Type I. On the top is a ridged roof-shaped capstone. The shaft has a butt. The crosshead and shaft are surrounded by perimeter rope mouldings and the decorated panels are correspondingly recessed. The shaft is divided into panels either divided from each other by flat horizontal mouldings or framed by rope mouldings. The base is rectangular, tapering towards the top. It has three steps, the first two being very shallow.Face A

1) Crosshead: there is a low boss in the centre of the crosshead and 4 smaller bosses, one at the end of each of the cross arms and one at the top of the shaft. They are decorated with traces of spirals or interlace.

The background is decorated with spirals.

No decoration on the wheel arcs may be identified.

Shaft:

2) Crucifixion: Christ is shown face on, His head and body erect, His eyes (drilled) open. The head is large in comparison with the body.

He has short hair and is beardless. He is clad in a knee length tunic with vertical drapery folds on the skirt. His arms are thin and short and traces of the cross may be seen behind. His legs are also thin and short terminating in tiny feet which are turned to either side and point downwards. To either side are the spear and spongebearers, the latter on the left holding a vinegar cup on the end of a rod just below Christ's chin. Both figures are shown in profile facing inwards, kneeling on one knee with their heads tipped slightly back. There is a second pair of figures either side of Christ's head. The one on the right faces inwards while that on the left, shown in profile in a crouched position, faces outwards.

- 3) Interlace: Enclosed pattern, type unknown, in 3 registers, 3 elements abreast.
- 4) Interlace: Spiralled and Surrounded B in 2 registers (UM: 2 cm; St W: 1.5 cm).
- 5) Butt: Undecorated.

Base:

- 6) Top step: no identifiable decoration.
- 7) Middle step: traces of a procession of horses, 4, possibly, 5, shown in profile facing left, their heads down.
Bottom step: this is divided into 3 panels by vertical roll mouldings.
- 8) Left: Interlace: Encircled pattern, type unidentifiable in 3 registers of 2 units.
- 9) Centre: A panel decorated with rows of low bosses.
- 10) Right: Interlace: Spiralled and Surrounded C in 3 registers (UM: 3 cm; St W: 1.5 cm).

Face B

Crosshead:

- 1) On the upper cross arm a single fret pattern unit, 2 ↯ elements crossed at right angles outlined in relief.
The upper wheel arc is divided vertically into 2 panels.
- 2) On the left a variation of 4 strand plaitwork (UM: 3 cm; St W: 1.5 cm).
- 3) On the right an unidentifiable fret pattern.

4) At the end of the horizontal cross arm interlace: an adaptation of Basic B, with outside strands (UM: 2 cm; St W: 1.5 cm).

The lower wheel arc is divided vertically into 2 panels.

5) On the left a fret pattern of interlocking $\frac{1}{2}$ ↕ elements.

6) On the right interlace: $4\frac{1}{2}$ registers of Simple B (UM: 1.5 cm; St W: 1.5 cm).

Shaft:

7) Changing Interlace: 1 unit of B Turned, 1 unit of D Turned, 8 strand plait with a bar terminal at the bottom and 1 unit of C Turned (UM: 2 cm; St W: 2 cm).

8) Spirals: single border of bossed spirals linked by 'S' scrolls in 4 registers. A small incised 'S' scroll crosses each large 'S' scroll at right angles.

9) Butt: Interlace: Basic A in 3 registers turned through 90° (UM: 3 cm; St W: 1.5 cm).

Base:

10) and 11) The traces of ornament on the upper 2 steps are too worn to identify.

12) On the bottom on the left traces of the Fall, the outlines of Adam and Eve confronting each other either side of the Tree. There are traces of other unidentifiable figures to the right.

Face C:

1) Crosshead: There are low bosses at the centre of the crosshead, on each of the cross arms and at the top of the shaft. They are all decorated with interlace: the central boss is quadranted, each section being decorated with a double stranded triquetra knot; the bosses on the horizontal cross arms are decorated with an interlace mesh, the other 2 with Basic C adapted as a roundel.

The background is decorated with frets: a carpet of χ elements.

The wheel arcs are decorated with zoomorphic ornament: traces of processions of quadrupeds with spiralled bodies.

Shaft:

2) Bossed spirals in an extended square panel pattern. The bosses show

traces of an interlace mesh. The 'C' and inner 'S' scroll expansions are triangular; the outer 'S' scroll expansions have a spiral curlicue.

3) Inhabited Vine-Scroll in 5 registers consisting of alternate pairs of birds and animals pecking at berry branches. At the top are 2 confronted birds with opened raised wings. The second and fourth registers have identical adored quadrupeds with short legs, round short snouted faces and small round ears. The third and fifth registers have adored birds with outstretched wings and large, slightly hooked beaks. Each creature is encircled by a vine stem. There is one trefoil shaped leaf in the top right hand corner. The vine has a central trunk the length of the bottom register. This disappears; the vine strands then pass back and forth across the centre of the panel. At the top there is a short length of 4 strand plait.

4) Butt: Frets: ↯ elements with curved terminals.

Base:

5) On the top step there is no surviving ornament.

6) On the middle step, plaitwork.

7) On the third step are traces of figures in 2 registers. All that can now be made out are 2 horsemen shown in profile facing left, placed one above the other.

Face D

Crosshead:

1) On the upper cross arm are traces of interlace, type unidentifiable. The upper wheel arc is divided vertically into 2 panels.

2) The left hand side is unidentifiable.

3) On the right is interlace, type unidentifiable.

4) At the end of the horizontal cross arm: interlace, type unidentifiable.

The lower wheel arc is divided vertically into 2 panels.

5) On the left interlace: Simple B with outside strands in $3\frac{1}{2}$ registers (UM: 1.25 cm; St W: 1.25 cm).

6) On the right frets: 4 separate units each with a ↯ element with 2 interlocking subsidiary ✓ elements.

Shaft:

- 7) Interlace: Encircled C, 4 registers of 1 unit (UM: 1.5 cm; St W: 1.5 cm).
- 8) Zoomorphic Interlace: A procession of quadrupeds with spiralled and interlaced bodies in 3 registers. A fourth animal head fills the top right hand corner. Each register is composed of a number of body features which, when viewed as a whole, give the impression of a beast with a spiralled body. Their heads are lion-like with small, round ears and square open jaws which bite at the next animal's tail.
- 9) Butt: Fragmentary interlace, type unidentifiable.

Base:

- 10) On the top step interlace: Spiralled and Surrounded A in 5 registers of one unit turned through 90° (UM: 2.5 cm; St W: 1.25 cm).
- 11) On the second step frets, 4 separate units each consisting of 2 elements crossed at right angles.
- 12) and 13) The lower step is divided vertically into 2 panels but there is no surviving ornament.

Bibliography

Ware	1658, 304
Ware & Harris	1739, II, 46
O'Neill	1857, 9, 10, 12
Crawford, H.S.	1907a, 225
Westropp	1907a, 291, 296
Westropp	1907b, 333
Macalister	1909, 153
Stokes, M.M.	1911, 118
Crawford, H.S.	1926a, No. 20; Fig 7H
Porter	1931, 112
Henry	1933, 53, 55, 98, 107, 109, 166; Fig. 61; Pls 55, 56
Henry	1940, 173, 175
Raftery, J.	1941, 89
Sexton	1946, 103-4
De Paor, M & L.	1960, 144, 146.

Roe	1962, 9
Henry	1964, 23-4, Pls 6, 8
Henry	1965, 139, 140, 141, 147, 148; Pls 84, 85.
Evans	1966, 181
Killanin & Duignan	1967, 170
Ryan	1973, 64
Harbison	1975, 203
Hicks	1980

CLONMACNOISE V (Clonmacnois, West Cross, Cross of the Scriptures)
Ch. X, P1 11.

Clonmacnoise, Offaly

NO10307

Type of Monument: Cross

Present Location: Probably in situ. Situated within the modern enclosure at Clonmacnoise to the west of the Cathedral and on the same alignment.

Evidence of Discovery: First recorded 1658.

Measurements:

H:		388 cm (152½")
W of Crosshead:		140 cm (55")
<u>Shaft:</u>	H:	165 cm (65")
	W:	53 > 47 cm (21" > 19")
	D:	34 > 33 cm (13½" > 13")
Base:	H:	78.5 cm (27")
	W:	116 > 77 cm (46" > 30½")
	D:	109.5 > 76 cm (41" > 30")

Stone Type: Fine yellow ochre sandstone with a pink tinge.

Present Condition: On the whole good though some of the carving is badly weathered, particularly on the base.

Description: The crosshead is Type V. Round flat discs have been added at the points where the wheel arcs touch the cross arms on both broad faces. The wheel has rolls, some of which are decorated with lines radiating from the centre. The upper cross arm has a roof shaped terminal decorated with interlace mesh and there are traces of gable finials on the narrow faces. There are small knobs on the ends of the horizontal cross arms on the Broad faces.

The shaft has perimeter roll mouldings banded at intervals with horizontal incised lines. It is divided horizontally into 3 panels, each framed by a roll moulding with a vertical break. There is a butt at the bottom.

The base is shaped like a truncated pyramid. Each face is divided horizontally into 2 panels.

Face A

Crosshead:

1) On the upper cross arm is a square panel pattern of bossed spirals

with triangular expansions.

2) In the centre the Crucifixion. Christ is shown face on, His body erect, His head tipped slightly down towards the left. He has short curly hair, is beardless and perhaps naked. The palms of His outstretched hands are enlarged. His feet, bound with rope, face outwards and rest on a suppedaneum. The spongebearer is placed on the left, the spear-bearer on the right. Both are shown in profile facing Christ, the former kneeling on one knee, the latter crouched. Above Christ's head is the bust of an angel shown face on.

3) and 4) On the horizontal cross arms are figures kneeling on one knee, each looking towards Christ. They carry staffs which terminate in a cup shape with an openwork circle beneath. The figure on the right seems to be clad in a short cloak.

5) and 6) The top left and bottom right wheel arcs are decorated with a single border of bossed spirals linked by 'S' scrolls.

7) and 8) Top right and bottom left wheel arcs: Zoomorphic interlace (?).

9) The upper disc on the wheel shows a horseman in profile facing left.

10) and 11) Those on the horizontal cross arm are undecorated.

12) That at the top of the shaft shows a dove, head downwards, its wings outstretched.

Shaft:

13) Three figures. Those on the left and right are shown three quarter face. They are clad in knee length tunics and carry spears. They have halos and the left hand figure shows traces of a moustache. Between them, the third figure is shown face on, his hands clasped in front of him. He is beardless with short hair and a halo.

14) Three figures, all beardless with short hair and halos. The 2 outer figures, shown three quarter face, are clad in knee length tunics. They clasp the hands of the third figure who is shown face on, his arms crossed in front of him. He is clad in an ankle length robe with traces of an overgarment with raised hem.

15) The Soldiers Guarding the Tomb: 2 soldiers are shown in profile

facing each other, their heads bent in sleep. They have pointed helmets. Their spears rest on their shoulders. To their right are parts of 3 figures. Two are just face on heads. The third is three quarter face with long hair and a cloak (?) with traces of drapery folds and holding a rectangular object.

At the bottom of the panel Christ is shown lying beneath a rectangular slab. He is swathed in bandages which are marked with 2 small relief crosses. The face appears uncovered, the border of the wrappings round it being decorated with pellets. A bird perches on the edge of the rectangular slab leaning down over Christ's face.

16) On the butt a fragmentary inscription.

Base:

17) The upper panel shows a central figure seated (?) face on with 3 figures either side shown in profile facing inwards. All are clad in long robes. The figures in profile appear to hold objects in front of them.

18) On the right of the lower panel are two figures shown in profile facing left.

Face B

Crosshead:

1) On the upper cross arm is a variation of a combined square panel pattern of bossed spirals. At the bottom of the pattern is an additional central spiral linked by a 'C' scroll to the bottom left spiral and on the right by a 'C' scroll to a small spiral curlicue making the pattern asymmetrical. The outer 'S' scroll expansions have spiral curlicues; the rest are triangular.

2), 3), 4). The upper wheel arc is divided vertically into 3. The outer 2 are undecorated. The central panel shows traces of unidentifiable ornament.

5) The panel at the end of the horizontal cross arm is faceted and has a horizontal perimeter roll moulding along the top and bottom. The centre is decorated with traces of frets.

6) Beneath the horizontal cross arm is the Manus Dei; the hand is surrounded by traces of a nimbus.

The lower wheel arc is divided vertically into 3:

7) and 8) The outer panels are decorated with a single border pattern of spirals linked by 'C' scrolls.

9) The central panel shows two serpents, their heads in the top and bottom left hand corners, their bodies entwined to form a figure of 8 loop. In the gaps formed are 2 face masks with short curly hair.

Shaft:

10) A face on seated figure with a face on winged figure behind his head. The first is clad in a long robe and slippers. He has short curly hair and a moustache (?). He holds a crozier in his right hand and possibly a second object in his left. Behind him are traces of a chair. The second figure has bossed spirals on the top of its wings and possibly a moustache.

11) A seated figure shown three quarter face playing a lyre. He is beardless and clad in a long robe with an upper garment showing traces of complex drapery folds. He is seated on a chair with zoomorphic features.

12) Anthropomorphic interlace in 2 registers. Each register consists of a rectangular area of plaitwork mesh each corner terminating in a human head shown in profile with long hair which becomes plaitwork strands. The 2 registers are joined by more plaitwork mesh. The gaps at the sides of the panel are filled with Spiralled A interlace.

13) The butt shows inhabited vine-scroll with 2 confronted winged quadrupeds. The plant stem grows between them, dividing at the top into 2 branches which each curl round an animal. There are traces of round vegetation buds.

Base:

14) On the left of the upper panel are 4 figures dressed in knee length tunics and carrying spears; on the right Jacob Wrestling with the Angel.

15) Below, a hunting scene. From left to right 2 deer pursued by 2 hounds and 2 men on foot, all shown in profile facing left. The first deer has antlers; the second turns its head towards its tail. The hounds are placed one above the other. The 2 figures are clad in knee length tunics and their right arms are raised.

Face CCrosshead:

- 1) The upper cross arm shows 3 figures, all beardless. The central figure is face on, those to either side three quarter face. Those on either side are in a crouched position and appear to grasp an arm of the central figure.
- 2) In the centre the Last Judgement Christ is shown face on clad in a long robe with drapery folds around the waist and a prominent collar. In his right hand he holds a T shaped staff with spiralled terminals and in the left a cross. He has short curly hair and a (?) moustache. His feet face outwards and rest on a suppedaneum. Below this is a thin rectangular object. Above Christ's head is a bird. On the right are 4 figures (three quarter face) turning away from Christ. The 3 on the right are merely busts; the figure next to Christ seems to push the rest before him. He is shown in profile clad in a cloak with a hood and has long spindly legs. To the left are 4 figures turning towards Christ. The 3 on the left are merely busts shown three quarter face. The fourth figure shown in profile squats and plays a cone shaped horn.
- 3) and 4) There are 4 further figures, again busts, on each of the horizontal cross arms in 2 rows of 2. Those on the left turn three quarters towards Christ; those on the right turn three quarters away from Him.
- 5), 6), 7), 8). The wheel arcs are decorated with zoomorphic interlace: processions of quadrupeds with spiralled bodies.
- 9), 10), 11), 12) The 4 discs on the wheel have bossed spirals entwined with serpents.

Shaft:

- 13) 3 figures. The central figure shown face on is seated. He is beardless with short curly hair and outstretched arms. He is clad in a long robe with a decorated hem border. At waist level there are a series of curved folds. The figures either side are turned three quarter face towards the centre. They have long beards and moustaches and are clad in long robes with shorter overgarments.
- 14) 2 figures, face on. They have moustaches and long plaited beards. They are dressed in long robes and cloaks fastened on each shoulder with

a circular brooch. They have swords hanging from belts round their waists. The left hand figure is handing the other a drinking (?) horn.

15) 2 men plant a staff in the ground. At the top of the staff is a human face mask. The right hand figure, turned three quarters towards the centre has long hair, a long beard and a moustache. He is dressed in a short sleeved, knee length tunic with a hem border decorated with pellets. From his belt hangs a sword. The left hand figure, turned three quarters towards the centre is dressed in a long robe, the hem border decorated with pellets. He has a shorter overgarment with hood, again with a decorated hem border. He is beardless with short curly hair. There are traces of shoes on his feet.

16) On the butt a fragmentary inscription.

Base:

17) The upper panel shows 3 horsemen in profile processing towards the left.

18) The lower shows two chariots each drawn by one (?) horse shown in profile moving towards the right. Two men are seated in each chariot, one behind the other. The front man carries a whip. The wheels each have 8 spokes.

Face D:

Crosshead

1) On the upper cross arm a fret pattern with some terminals raised into bosses.

2), 3), 4) The upper wheel arc is divided vertically into 3 panels; probably undecorated.

5) At the end of the horizontal cross arm a faceted panel with a horizontal roll moulding along the top and bottom. No traces of ornament.

6) The panel below the horizontal cross arm shows a crouched cat, its tail curled round. It holds a fish in its paws, grasping the fish's tail in its mouth.

7), 8) The lower wheel arc is divided vertically into 3 panels. The outer 2 are decorated with Interlace, Half A (UM: 2.5 cm; St W .5 cm). ending in bar terminals top and bottom.

9) The central panel as B 9 except that only one snake, its head in the top left hand corner entwines round the face masks.

Shaft:

10) A seated(?) figure with the bust of a second figure behind. Both are shown face on and are beardless with short curly hair. The lower figure is clad in a long robe with decorated hem border and a long outer robe with a curled up hem. He holds a tau crozier between his knees. The figure behind is dressed in a garment with long flowing sleeves. He holds a book in his right hand.

11) A seated figure playing a 3 reed pipe. He is dressed in a long robe with a decorated hem border. His head is tilted down towards the right and he has long hair. Two cats are placed back to back at his feet, their back legs entwined. A third cat, in the top left hand corner, leaps in the air. It clutches its back legs with its forepaws.

12) A seated figure, beardless with short curly hair, his legs shown in profile facing left, but with the upper part of his body turned face on. He is dressed in a long robe with a decorated hem border and drapery folds around the upper half of his body. The chair is curved with a spiralled top. In his right hand he holds a staff with a bird on the top and with the tip he seems to be poking the eye out of a man sprawled beneath his feet, his legs in the air. This man is beardless with short curly hair.

13) On the butt, inhabited vine-scroll. Two adored quadrupeds (?) The vine stem grows between them, bifurcating at the top into 2 fronds which curl above the creatures, breaking into round vegetation buds, the gaps being filled with interlace loops.

Base:

14) A procession of exotic beasts shown in profile facing left. From left to right: the first is a winged quadruped; its head appears to face its tail. The second is a winged quadruped with a hooked bird beak and a crest on its head. The third, also a winged quadruped, has a long feline tail arched above its body.

15) A second procession of exotic beasts shown in profile facing right. The first 3 are quadrupeds, 2 possibly with antlers. The fourth beast, also a quadruped, has been placed vertically, its head towards the top of the panel.

Bibliography

- Ware 1658, 304
- Ware & Harris 1739, II, 46
- Ware & Harris 1764, 165, plate
- Archdall 1786, 392
- Petrie 1845, 272-5, 409
- Petrie 1872, 42-4; Pl XXXLIII
- Allen 1885, 84, 132-4, 136, 151, 203
- Allen 1896-7, 312
- Stokes, M.M. 1898, vii, xii, xiii
- Allen 1904, 190
- Crawford, H.S. 1907a, 224
- Westropp 1907a, 290-7
- Westropp 1907b, 333-4
- Macalister 1909, 153
- Champneys 1910, 83-5, 89-92, 94-6, 226; Pl XXXIX.
- Crawford, H.S. 1910
- Coffey 1910, 25
- Stokes, M.M. 1911, 107-8, 118
- Gougard 1920, 129, 139, Pl XI.5
- Crawford, H.S. 1926a, 5-6; Nos 105, 143, 146, 157, 160; Fig. 1
- O'Donovan 1926, 166-97
- Macalister 1928, 270, 326, 329; Fig. 14
- Porter 1929, 90; Fig. 7,8
- Henry 1930a, 90, 92, 94, 96, 100, 102, 106
- Porter 1931, 9, 12-3, 25, 26, 27-8, 29, 30, 31, 42, 44, 52, 57, 73, 109, 110, 112, 116, 117; Figs 6, 15, 23, 26, 36, 39, 40, 41, 51, 60, 73, 108, 109, 117, 128, 183, 218, 270.
- Gougard 1932, 351
- Henry 1933, 17, 18, 50, 55, 89, 117, 123, 132, 137, 156, 157, 159; Pls 34, 37, 78, 82, 87.
- Morris 1934, 207
- Henry 1940, 166, 173, 178, 180, 183, 186
- Sexton 1946, 29-30, 107-114.
- Macalister 1949, 70-1, Pl XXVII
- Roe 1949, 56-7

- De Paor, M & L 1960, 102, 146, 147.
Henry 1964, 18, 30-2; Pls. 45-50
Evans 1966, 181
Henry 1967, 47, 107, 114, 123, 136, 137, 139, 140, 156,
157, 158, 159, 167, 172, 173, 182, 184, 191, 196;
Pls 90-95, 110, 112.
Killanin & Duignan 1967, 171
Henry 1970, 37, 39, 132
Ryan 1973, 64-5
Harbison 1975, 203
Harbison et al 1978, 63, Fig. 49.
Harbison 1979
Henry 1980
Ó Murchadha 1980

CLONMACNOISE VI (Clonmacnois)

Ch XI, P1 12

Clonmacnoise, Offaly

NO10307

Type of Monument: ShaftPresent Location: Exhibited amongst the grave slabs in the grounds of Clonmacnoise.Evidence of Discovery: This is probably the monument mentioned by Françoise Henry in 1965 as being found during repair works in 1957. First definitely mentioned 1967.Measurements:

H: 59 cm (23½")

W: 33 cm (13")

D: 16.5 cm (6½")

Stone Type: Yellowish sandstone.Present Condition: The shaft is broken away at the upper end. The carving is well preserved. The shaft has been mounted on a modern pedestal.Description: The shaft tapers at the top. It has a double perimeter roll moulding.Face A:

1) Two confronted quadrupeds, their long snouts and legs interlocked. They have pointed ears, large eyes with raised irises and hollowed pupils, a striped area above the snout and prominent teeth. Long manes curl down their backs and they have long tails with curled ends.

Face B:

1) Interlace: Basic E (UM: 2.5 cm; St W: 1.25 cm) in 4 registers with an extra row of strands top and bottom.

Face C:

1) Interlace: Basic C 4 elements abreast (UM: 2.5 cm; St W: 1.25 cm) with 4 surviving registers.

Face D:

1) Interlace: Basic E (UM: 2.5 cm; St W: 1.25 cm) in 4½ registers.

Bibliography

- ?Henry 1965, 143.
Hunt 1967, 130
Harbison 1975, Fig. 61
Hicks 1980, 16; Fig. 4b.

DRUMCULLIN I (Drumcullen)

Ch. VIII, P1 13

Ballincur, Offaly

N181061

Type of Monument: CrossheadPresent Location: It is situated to the West of the church in Drumcullin graveyard. It is placed on top of Drumcullin II.Evidence of Discovery: Found by Olive Purser, August 1917.Measurements:

H: 61 cm (24") approx.

W: 57 cm (22") approx.

D: 18 cm (7")

W of crosshead (reconstructed): 82 cm (32") approx.

Stone Type: Pale grey limestone.Present Condition: Fragmentary and badly weathered. Only one wheel arc survives.Description: One of the horizontal cross arms is slotted into Drumcullin II making any carving impossible to see. The crosshead is Type III(?). It is surrounded by a perimeter roll moulding and an inner roll moulding.Face A:

1) Crucifixion: Christ is shown face on, his head and body erect, his eyes open. He has short hair and is beardless. He appears to be clad in a garment of some kind decorated with 2 vertical raised bands which stretch downwards from the neck. Only the right arm is visible terminating in a large outstretched palm. There is a small boss at the end of the horizontal cross arm and traces of a roundel on the upper cross arm.

2) On the surviving wheel arc interlace: 2 strand twist.

Face B:

1) At the end of the horizontal cross arm interlace: Half A (?).

Face C:

1) The central roundel is surrounded by a roll moulding. It is

decorated with a spiral roundel with a central spiral and 6 outer spirals joined by 'C' scrolls. The expansions are slashed.

2), 3), 4) The surviving parts of the crossarms are decorated with a plaitwork mesh, some strands being broken and rejoined to form loops.

5) The surviving wheel arc: as A 2.

Face D:

No surviving ornament.

Bibliography:

- | | |
|--------------------|-------------------------------|
| Crawford, H.S. | 1918, 178 |
| Purser | 1918 |
| Henry | 1933, 49, 80; Pl. 97; Fig. 41 |
| Sexton | 1946, 127 |
| Henry | 1967, 137 |
| Killanin & Duignan | 1967, 342 |

DRUMCULLIN II (Drumcullen)

Ch. VIII, P1 13

Ballincur, Offaly

N181061

Type of Monument: BasePresent Location: Possibly in situ. Situated to the West of the church in Drumcullin graveyard.Evidence of Discovery: First mentioned in 1918 but it was known before this date.Measurements:

H:	45 cm (19½")	above M.G.S.
Diam:	90 cm (35½")	
<u>Socket:</u> W:	40 cm (16")	
D:	24 cm (9½")	
H:	Unknown	

Stone Type: Mid-grey limestonePresent Condition: The base is badly cracked on both sides of the socket. Badly effected by lichen.Description: The base is cylindrical. Purser (1918, Fig. C) records the upper part of the socket as rectangular, the lower circular. This is no longer visible because of the position of Drumcullin I. No traces of ornament.Bibliography

Purser 1918

DUNNAMAGGAN (DONMAGGIN)

Ch XI, P1 14

Dunnamaggan, Kilkenny

S480410

Type of Monument: CrossPresent Location: Probably in situ. It stands in Dunnamaggan graveyard to the north of the ruined church.Evidence of Discovery: First mentioned by the Ordnance Survey in 1839 (O'Donovan 1928b, II, 92). At that time the shaft was standing in the base while fragments of the crosshead lay beside it. In 1852 (Carrigan 1905, IV, 36) the broken pieces were restored to their rightful positions using iron cramps by Rev. Cecil Russell, landlord of Dunnamaggan.Measurements:

H above MGS:	218 cm (85½") approx.
W of crosshead:	81 cm (28")
<u>Shaft:</u> H:	86 cm (33¾")
W:	42 < 47 cm (16½ < 18½")
D:	20 cm (8")
<u>Base:</u> H:	50 cm (19¾") approx.
W:	107 cm > 71 cm (42" > 28") approx.
D:	100 cm > 46 cm (39¼" > 18") approx.

Stone Type: Cross: Fine mid-grey sandstone

Base: Rough pinkish-grey sandstone with large intrusions.

Present Condition: Severely weathered and badly overgrown. The iron cramps have been replaced by cement.Description: It has a large circular crosshead (unclassifiable). The crossarms protrude very slightly beyond the wheel. The two holes above the horizontal crossarms are square; those below are circular. The short shaft tapers towards the bottom on the broad faces. The base is a truncated pyramid in shape with 2 steps. There is no visible ornament on the base.Face A:1) Crosshead: The ring has a flat perimeter moulding defined by an incised line. In the centre is a roughly cruciform hollowed area inside which is the Crucified figure of Christ. His head tips down

towards the left. His arms are slightly raised.

2) Shaft: There are traces of an incised dog tooth along the line of the wheel at the top of the shaft. The shaft is decorated with a recessed ogee arch in which stands a male (?) figure face on, his right hand raised in benediction. In his left he holds a staff which crosses his body diagonally. He is dressed in long robes with indications of two vertical drapery folds and a collar with crossed bands at the front.

Face B:

1) Crosshead: No ornament.

2) Shaft: There is a small face on figure, possibly with wings, at the bottom of the shaft. It wears a long robe, has shoulder length hair and is praying.

Face C:

1) Crosshead: The crosshead has a central boss. The ring is outlined by a flat perimeter moulding decorated with an incised dog tooth design. There is further dog tothing round the square holes. On the left horizontal crossarm is an incised roundel with a central cross and surrounded by dog tothing. No ornament survives on the right horizontal crossarm. On the upper crossarm is an incised star.

2) Shaft: The upper half is divided vertically into 3 by 2 incised lines. Below is a slightly pointed recessed archway with a 'crinkly' edging in which stands a face on figure with a long robe and a roof shaped head-dress.

Face D:

1) Crosshead: No ornament. There are 2 small holes at the end of the horizontal crossarm.

2) Shaft: Towards the bottom is a slightly pointed recessed archway in which stands a face on figure in a long robe holding a shield (?).

Bibliography

- | | |
|----------|-----------------|
| O'Neill | 1857, Pl III |
| Carrigan | 1905, IV, 35-7. |

Crawford	1907a, 223
Macalister	1928, 327
O'Donovan	1928b, II, 92
Sexton	1946, 133
Killanin & Duignan	1967, 314
Lahert	N.D, 4-6

DURROW I

CH. X, P1 15

Durrow Demesne, Offaly

N320308

Type of Monument: CrossheadPresent Location: Not in situ (Stokes, M.M. 1898, 9). It now stands in the churchyard to the west of the ruined church belonging to Durrow demesne.Evidence of Discovery: First mentioned 1867.Measurements:

H:	368 cm (144½")
W of crosshead:	127 cm (50")
<u>Shaft:</u>	H: 161 cm (63½")
	W: 44.5 < 45 cm (17½" < 18")
	D: 33 > 30 cm (13" > 11¾")
<u>Base:</u>	H: 58 cm (22¾")
	W: 123 > 65 cm (48" > 25½")
	D: 65 > 57 cm (25½" > 22½")

Stone Type: Fine greyish pink sandstonePresent Condition: In places the carving is severely weathered.Description: The crosshead is Type IV with rolls attached to the 4 wheel arcs. The upper cross arm has a roof shaped terminal decorated with a shingled effect and with finials on both gables.

The shaft has perimeter roll mouldings banded at intervals with horizontal incised lines. It is divided horizontally into 3 panels framed by a roll moulding with a vertical break. There is a butt at the bottom.

The base is shaped like a truncated pyramid. It has 3 steps; the upper 2 are very shallow. The mouldings are indicated by incised lines. Faces A and C are divided vertically into 2 panels. Faces B & D have one. No decoration.

Face A

The crosshead is framed by a roll moulding. The vertical perimeter mouldings at either end of the horizontal cross arms have traces of plaitwork ornament and the corners are embellished with knobs.

1) In the centre the Crucifixion. Christ is shown face on, his body

erect, His head tipped slightly down towards the left. He has short curly hair, is beardless and is clad in a loin cloth. The palms of His outstretched hands are enlarged. His feet, bound with rope, face outwards and rest on an area of interlace mesh. The spongebearer is placed on the left, the spearbearer on the right. Both are shown in profile facing Christ. They kneel on one knee. Above Christ's head is a bird shown face on with outstretched wings and an arch with spiralled terminals above its head.

2) On the upper cross arm are 3 figures. The central figure is shown face on and seated. Those on either side are standing and shown three quarter face. They are beardless with short curly hair and ankle length robes.

3) On the left horizontal crossarm are 2 seated figures shown in profile facing right. The left hand figure is seated on a stool. He is dressed in an ankle length robe, has a moustache and holds a horn. Between the 2 figures is a bird shown in profile facing right.

4) On the right horizontal crossarm are 2 seated figures shown in profile facing each other. The right hand figure, seated on an 'L' shaped stool, is bearded and clad in a long robe, his hands placed in front of him. The second figure, seated on the ground, holds up a rod with a circular terminal.

5) and 6) The top left and bottom right wheel arcs are decorated with a single border of bossed spirals linked by 'S' scrolls.

7) and 8) Top right and bottom left wheel arcs: Zoomorphic interlace.

Shaft:

9) Three figures. The central figure is shown face on. He has short curly hair, is beardless and clad in a long robe. The figures on either side are three quarter face. They have short hair, are beardless and are clad in knee length tunics tied with belts. They each rest a sword on the shoulder facing the viewer.

10) Three figures. The figure on the left is shown in profile facing right. He wears a pointed helmet and a belted knee length tunic. He has a moustache. With one hand he grasps the arm of the central figure, in the other he holds an object. The central figure is shown three quarter view facing left. He has short curly hair, is beardless and

wears a long robe with a shorter overgarment. The figure on the right is shown three quarter view (?) facing left. He wears a knee length tunic with a belt. He grasps the central figure round the waist.

11) The Soldiers Guarding the Tomb: 2 soldiers are shown in profile facing each other; their heads bend in sleep. They have helmets with curved crests (?). Their spears rest on their shoulders. The left hand figure has a moustache. Between them is the bust of a third figure with a halo (?). Below Christ (his head missing) is shown lying beneath a rectangular slab, His body wrapped in cloth. A bird shown in profile facing left perches on the end of the rectangular slab, its head bent towards Christ's face.

12) On the butt a fragmentary inscription.

Face B:

Crosshead:

1) On the upper cross arm there is no surviving ornament on the gable end of the roof shaped terminal.

2) Below there is a horseman shown in profile facing left.

3) The upper wheel arc is divided vertically into 3. No surviving ornament.

4) The panel at the end of the horizontal cross arm is faceted with horizontal perimeter roll mouldings along the top and bottom. The centre shows traces of fret ornament.

The lower wheel arc is divided vertically into 3.

5) On the left are spirals.

6) The centre shows a two strand twist with a serpent's head terminal at the top. The serpent's body is decorated with pellets. In the gaps between the loops are 3 face masks with curly hair.

7) On the right there are traces of abstract ornament.

Shaft:

8) A figure seated face on dressed in a long robe. He has short hair, a moustache and a long plaited beard. There is a sword with a central groove on the blade which he holds upwards in his right hand. On the left is a round shield and projecting behind this are traces of

a spear. To either side of the figure are 2 quadrupeds placed vertically, their heads resting on the figure's knees.

9) To the right is a figure seated face on, his hands resting on his knees. There are traces of drapery folds round his knees and drapery bands hang vertically downwards from his shoulders. The left hand figure is shown in profile facing right. He wears a knee length belted tunic and a pointed helmet with a neck guard. He holds a large spoon-shaped object in his right hand and appears to hit the first figure on the head with it.

10) The Fall: 2 figures are shown in profile facing each other, Adam on the right and Eve on the left. Adam is bearded. They each grasp the apple. The Tree grows between them breaking into 4 branches at the top of the trunk to form 2 spiralled knots dotted with round vegetation buds.

11) On the butt inhabited vine-scroll. There are 2 confronted winged quadrupeds. A vine stem grows between them bifurcating at the top of the panel. There are suggestions of foliage.

Face C:

Crosshead: This is framed by a roll moulding.

1) On the upper cross arm is zoomorphic ornament with 4 bosses in 2 registers of 2 decorated with a brambled effect. From each of these coils the body of a serpent, their heads crossing in the centre.

2) In the centre is Christ shown face on, beardless and with short curly hair. He is dressed in a long robe with traces of 'U' shaped drapery folds. He holds a cross in His left hand, a flowering rod in His right. Above His head is a quadruped shown in profile facing left placed in a roundel. Below His feet is a row of Simple E elements.

3) On the left horizontal cross arm there are 2 seated figures. The left hand figure is shown three quarter view. He sits on an 'L' shaped stool and plays a lyre. The right hand figure is shown in profile facing right. He is dressed in a long robe and cloak (?) and plays a pipe. To his right is a bearded severed head.

4) On the right horizontal cross arm, David breaking the jaws of the lion. David and the lion are shown in profile facing left with David

placing one knee on the lion's back while he prizes open the lion's jaws with his hands. To David's right is a shepherd's crook and a sling stone. To the left is a sheep shown in profile facing left, its head turned towards its tail. To Christ's right there is a figure shown in profile facing left. He is dressed in a cloak (?) and appears to clap his hands.

5), 6), 7), 8) The ornament on the wheel arcs is fragmentary. There are traces of zoomorphic interlace, 2 registers of 2 confronted animals, their front and back legs interlaced, on the bottom left (7). On the bottom right (8) are traces of a fret and spiral pattern.

Shaft:

9) The Sacrifice of Isaac: Isaac is on the right. He is shown in profile facing left kneeling before a low, two legged altar. He carries a basket on his back secured by a rope over his shoulder and an axe in his left hand. On the left is Abraham shown three quarter view facing right. He has short curly hair and is beardless. He holds a sword in his right hand resting it on his right shoulder and his left hand is raised above Isaac's head. In the top right hand corner is a kneeling figure shown in profile facing left holding an animal, also shown in profile facing left, by the back legs.

10) Interlace: Encircled D, 2 registers of 2 units (UM: 2 cm approx; St W: 1.5 cm) with Simple E elements acting as fillers and a diamond shaped knot in the centre.

11) Two figures seated on low 'L' shaped chairs. They face each other, their heads three quarter face. They have short curly hair, are beardless and dressed in long robes. Between them is a rectangular object which they stretch one hand towards. In the centre is a third figure depicted on a slightly larger scale. He is shown face on, has short curly hair and is beardless and there are complex drapery folds round his neck. The lower part of his body is unclear. In the top corners are 2 angels, shown three quarter view, looking down on the seated figures below. Their wings are incised with long vertical lines.

12) There are traces of carving on the butt including a circular feature on the left hand side. Possibly similar to B 11?

Face D:

Crosshead:

1) On the gable end of the upper cross arm is a boss with serpents

emanating from it.

2) Below is a crouching figure shown face on, its hands outstretched. It has prominent ears and is clad in a long robe with traces of drapery folds across the chest.

3) Upper wheel arc: No surviving ornament.

4) The panel at the end of the horizontal cross arm is faceted with a perimeter horizontal roll moulding along the top and bottom. The central panel is divided into 4 triangles cut by diagonals with a pellet in the centre and decorated with an interlace rectangle made up of element C loops (St W: 1 cm).

The lower wheel arc is divided vertically into 3 panels.

5), 7) The outer panels are decorated with a variation of spiral ornament.

6) The central panel: as B 6.

Shaft:

8) Two figures shown three quarter view facing left. The left hand figure is clad in a long robe with a hem border decorated with pellets and tied at the waist with a brooch (?) at the neck and some kind of head-dress. A child is carried on the figure's back. The second figure with short curly hair has a similar robe with numerous drapery folds round the waist. The right hand holds these while the left is raised towards the mouth.

9) Spirals: A double border pattern of 'C' scrolls in 4 registers. The triangular expansions are slashed.

10) Jacob and the Angel: 2 figures, one in profile, the other three quarter face, are shown, their arms locked round each other's waists.

11) On the butt a fragmentary inscription.

Bibliography

Keane	1867, 427; Fig. 15
Petrie	1878, 54-6
Allen	1887, 134, 228
Williams	1897, 146-7; Figs. 8, 9
Stokes, M.M.	1898, v, 8-12.

- Williams 1899, 49
- Stokes, M.M. 1901, 574
- Crawford, H.S. 1907a, 225
- Champneys 1910, 83, 85, 89, 95, 225; Pl XXXIX.
- Gougard 1920, 129; Fig. 7.
- Crawford, H.S. 1926a, Nos 10, 11, 98, 121, 130, 135, 141, 162, Pl. III. Fig. 2A.
- Porter 1929, 85, 88, Pl. 1.
- Henry 1930a, 99, 102, 104, 106; Fig. 4.
- Porter 1931, 10-11, 28, 40, 43, 44, 52-3, 57, 74, 91, 110, 115, 121, 124-5, 127; Figs. 9, 47, 55, 58, 59, 68, 69, 111, 205, 240, 241, 266.
- Gougard 1932, 351
- Henry 1933, 18, 27, 54, 55, 66, 130, 132, 137, 156, 157, 159; Figs. 97, 127; Pls 55, 79, 80, 81, 84, 85.
- Morris 1934, 207, 210
- Lowry-Corry 1935, 154
- Henry 1940, 166, 173, 180
- Sexton 1946, 29, 135-41
- Macalister 1949, No. 591
- Roe 1949, 43, 52, 57, 59; Figs. 2.12, 9.32, 11.39.
- De Paor, M. & L. 1960, 102, 147
- Henry 1964, 18, 30-2; Pls 51-5
- Henry 1967, 136, 139, 140, 156, 158, 159, 165, 172, 174, 179, 183, 191, 201; Pls 98-100, 109.
- Killanin & Duignan 1967, 448-9
- Henry 1970, 2, 123
- Harbison 1975, 205-6.

DURROW II

Ch XI, Pl 16

Durrow Demesne, Offaly

N320308

Type of Monument: CrossPresent Location: Missing since 1975

Evidence of Discovery: First mentioned 1897. At that time it was situated on top of the East gable of the eighteenth century church belonging to the Durrow Abbey estate. The cross fell off the gable c1959-60 and in 1961 Françoise Henry (1963) found it standing in the old limestone gable finial near the North wall of the church.

Measurements: (After Henry 1963)

H: 17" (43 cm)
 W of crosshead: 27" (68.5 cm)
 D: 7.7/10" > 5 $\frac{3}{4}$ " (19.5 > 14.5cm).

Stone Type: Creamy coloured sandstone with dark flecks.

Present Condition: Unknown. Previously the cross had been recut in order to mount it as a gable finial. The shaft of the cross had been cut into a tenon. Henry (ibid) states that there was a deep socket in the upper cross arm and that a hole had been cut in one side of this to allow rainwater to drain away. The carving was badly weathered.

Description: The crosshead is unclassifiable. The crossarms expand considerably towards the end. Faces B and D have no surviving ornament except for perimeter roll mouldings.

Face A:

In the centre of the crosshead is the Crucifixion. Christ is shown face on, his body erect, his arms with open palms sloping slightly downwards. He is beardless. There are no traces of clothing. Beneath each armpit is a raised circular area of carving. A bird-like object perches on His head. At the extremity of each horizontal cross-arm is a boss with 2 serpents spiralling from it. The crosshead is surrounded by a perimeter roll moulding which broadens beneath the horizontal crossarms.

Face C:

In the centre of the crosshead is the upper part of a figure

shown face on. The figure has short curly hair and carries a crozier in the left hand and there may be further traces of carving behind this. On the horizontal cross arms there is interlace derived from a plaitwork pattern. There are traces of ornament on the upper cross arm. The perimeter moulding: as A.

Bibliography

- | | |
|--------------------|--------------------------|
| Williams | 1897, 135, Fig. 3 |
| Crawford, H.S. | 1907a, 225 |
| Porter | 1931, 43 |
| Henry | 1963 |
| Henry | 1964, 32; Pl. 61 |
| Killanin & Duignan | 1967, 448 |
| Henry | 1970, 123, 126-7; Pl. 50 |
| Harbison | 1975, 206. |

DURROW III

Ch XI, P1 17

Durrow Demesne, Offaly

N320308

Type of Monument: Crossbase.Present Location: Missing? Last mentioned by Henry (1963).Evidence of Discovery: First mentioned 1897 as the 'headache stone'. It was situated on the other side of the drive in a plantation to the South East.Measurements: (After Henry 1963)

H:	?
W at top:	29½" (75 cm)
D at top:	22½" (57 cm)
Socket W:	10" (25.5 cm)
D:	7½" (18.5 cm)

Stone Type: UnknownPresent Condition: Unknown. Photographs from the 1930s (P1 17) show part of the upper surface of the base broken away.Description: The Base is shaped like a truncated pyramid. There are no indications of carving except for a perimeter roll moulding round the top.Bibliography:

Williams	1897, 135
Crawford, H.S.	1907a, 225
Henry	1963, 84
Harbison	1975, 206.

GALLEN PRIORY I

Ch XI, Pl 18

Ferbane, Offaly

N117235

Type of Monument: Cross SlabPresent Location: It has been erected within a modern enclosure on the site of the church in the grounds of Gallen Priory.Evidence of Discovery: Found by Sir Andrew and E.C.R. Armstrong in October 1907 in a mound overlying the church which was excavated by T.D. Kendrick 1934-5.Measurements:

H: 163 cm (64½")

W: 70 cm (27½")

D: 18 > 15 cm (7" > 6")

Present Condition: The top right hand corner has been broken away. The carving is mostly well preserved.Description: At the top of the slab is a tenon (H: 10 cm; W: 33cm; D: 9 cm) and beneath this is a hole (Diam: 5 cm) which forms a slot on Face C. Above this is a second smaller hole on Face A only. On the bottom of Face C is a plinth (H: 15 cm). Faces B, C and D are undecorated.Face A

The slab is surrounded by a triple roll moulding and a horizontal triple roll moulding divides the face into 2 panels.

1) This panel is dominated by a Greek cross with expanded crossarms composed of an interlace mesh (St W: 2.5 cm) with a pellet at the centre. Some of the strands bifurcate. In each corner is a triquetra knot and a 'C' scroll with a slashed triangular expansion.

2) The lower panel has two motives:-

a) Two confronted quadrupeds shown facing each other, their legs in motion. They have slender bodies, elongated chins and feline ears. Their tails curl into figure of 8 motives above their heads terminating in tufts.

b) An incised fret pattern forming a carpet of interlocking ↕ and ↗ elements. In the centre an inset with a quadruped

shown in profile facing left. It has a spiralled hip joint. It has one antler and holds a serpent (?) in its mouth.

Bibliography

- | | |
|----------------|-------------------------------------|
| Armstrong | 1908a, 62-3, Fig. 2 |
| Crawford, H.S. | 1908a, 181 |
| Macalister | 1908, 323-4 |
| Crawford, H.S. | 1918, 178 |
| Henry | 1933, 96, 123, 164; Fig. 91; Pl 17. |
| Kendrick | 1939, 7, 9, Pl 1. |
| Henry | 1940, 55-6, 59, 60 |
| Henry | 1965, 123, 125, 156; Pl 64 |
| Evans | 1966, 181 |
| Harbison | 1975, 206 |

GALLEN PRIORY II

Ch XI, Pl 19

Ferbane, Offaly

N117235

Type of Monument: UnknownPresent Location: LostEvidence of Discovery: Found by E.C.R. Armstrong at Gallen Priory in 1908.Measurements: (After Armstrong 1908b)

H: 11 7/8" (30cm)

W: 10 5/8" (27cm)

D: ?

Stone Type: Unknown.Present Condition: -Description: A sculptural fragment with a tenon at the bottom. It has been broken away at the top. There are no recorded comments on Faces B and D.Face A:

The panel is framed by a roll moulding. A quadruped is shown in profile facing left, its head turned to face its feline tail which it clasps in its jaws. It has 3 toed feet.

Face C:

Interlace: Fragmentary 4 strand plait (median line). It is enclosed in a single roll moulding at the bottom and a double roll moulding on the vertical sides.

Bibliography:

Armstrong

1908b, 391-2, Figs. 2 and 3.

GRAIGUENAMANAGH I (North Cross; Ballyogan Cross) Ch IX, Pl. 20.

Graiguenamanagh, Kilkenny

S710437

Type of Monument: Cross

Present Location: Now erected in the graveyard at Duiske Abbey.

Evidence of Discovery: First mentioned 1857 when it had been inserted into the wall of the National School in the grounds of Duiske Abbey.

Shearman suggested it originated from Ullard but Galpin suggested Ballyogan.

Measurements:

H: (excluding base)	144 cm (56 $\frac{3}{4}$ "
W of crosshead:	58 cm (22 $\frac{3}{4}$ "
<u>Shaft:</u>	
H:	82 cm (32 $\frac{1}{4}$ "
W:	31 cm (13"
D:	21 cm (8 $\frac{1}{4}$ "
Base: H (reconstructed):	83 cm (32 $\frac{3}{4}$ "
W:	c 57 > 45 cm (23" > 17 $\frac{1}{2}$ "
D:	46 > 22 cm (18" > 8 $\frac{3}{4}$ "

Stone Type: Mid grey granite

Present Condition: A portion of the shaft is missing at the bottom. Part of the base has been reconstructed with modern concrete. The base is severely weathered but the carving elsewhere is in relatively good condition.

Description: The crosshead is Type I a. There is a low plinth on the top of the upper crossarm. The crosshead and shaft are surrounded by perimeter roll mouldings. The base is shaped like a truncated pyramid with rounded corners and has perimeter roll mouldings.

Face A:

The crosshead is framed by a roll moulding.

1) It is decorated with the Crucifixion. Christ is shown face on, his body erect, his eyes open. He has short hair and is beardless. He is clad in a long robe with decorated hem border, an overgarment, and there are some indications of drapery round His neck. His shoulders are very rounded and His arms and hands enlarged. To either side are the small figures of the spear and sponge bearers shown in profile facing Christ. Above Christ's head are the busts of 2 angels with flap-like wings.

2), 3), 4), 5) The wheelarcs are decorated with Z elements.

The shaft is divided into 3 panels each framed by roll mouldings.

6) The Fall: Adam and Eve are shown either side of the Tree, the 2 branches of which are incorporated into the roll moulding by the addition of vegetation buds. To the left Adam is shown in profile facing right. He is bearded (?) and clad in a tunic with a cloak, longer at the back than at the front. He stretches his right arm across the tree trunk. Eve is shown face on dressed in a long robe, her feet pointing forward.

7) The Sacrifice of Isaac: On the right Abraham is shown in profile facing left. He is clad in a knee length garment, longer at the back, with a delineated hem border. His right arm is raised and he holds a raised sword and with his left he grasps Isaac's body. Isaac is shown in profile bending back over a two legged altar in the bottom left hand corner. He wears a short garment. In the top left hand corner is the ram shown in profile facing right.

8) David, the Harpist: The lower end of this panel is missing. David, bearded (?), is shown in profile facing right dressed in a tunic or robe. His right arm is stretched across the strings of a harp which has a thick frame on the left side, a much thinner frame on the right.

The Base is divided horizontally into 2 panels, each framed by a roll moulding.

9) Frets: a carpet of interlocking [elements.

10) Interlace: plaitwork (St W: 2 cm approx).

Face B:

1) Crosshead: Undecorated. There is a vertical line down the centre of the upper and lower wheel arcs and the panel at the end of the horizontal cross arm has a perimeter roll moulding.

2) Shaft: Frets: At the top a single Z element with fragmentary triangular elements used as fillers. Below a Double border of crude [elements outlined in relief in 4 registers.

3) Base: Interlace: Traces of 2 units of a closed circuit pattern of oval rings (RA No. 766).

Face C:

- 1) On the upper cross arm 2 figures in profile (?) facing each other dressed in long robes. They seem to clasp each other round the waist.
- 2) On the rest of the crosshead and the majority of the shaft: Spirals joined by 'S' scrolls 3 elements abreast and 10 registers high. Pellets are used as fillers. At the ends of the horizontal cross arms single units of a closed circuit pattern of oval rings (RA No. 766).
- 3), 4), 5), 6) Wheel arcs: Traces of ornament only.
- 7) The panel framed by roll mouldings at the bottom of the shaft shows 3 figures. On the left 2 figures shown in profile facing each other and grasping each other round the waist. The third figure is face on and wears a long robe.
- 8) Base: No surviving ornament.

Face D:

- 1) Crosshead: There is a vertical line down the centre of the upper and lower wheel arcs. The panel at the end of the horizontal crossarm has a perimeter roll moulding and there may be traces of decoration on it.
- 2) Shaft: Spirals: a combined double border pattern in $4\frac{1}{2}$ registers. The bottom is missing.

The Base is divided horizontally into 2 panels.

- 3) No traces of ornament.
- 4) Interace: RA 766. 2 registers of 2 units survive.

Bibliography

O'Neill	1857, 3; Pl. 9
Shearman	1874-5b, 507
Allen	1887, 160
Crawford, H.S.	1907a, 223
Champneys	1910, 82, 87, 93
Stokes, M.M.	1911, 120
Galpin	1913, 13
Crawford, H.S.	1926a, No. 13
Porter	1931, 27, 111; Fig. 143

Henry	1933, 54, 107, 130, 137, 138, 140, 144, 165, 206; Figs. 76, 105; Pls 49, 50.
Henry	1940, 169, 173
Sexton	1946, 165-6
Roe	1949, 58
De Paor, M. & L.	1960, 149
Henry	1964, 25-6, 70
Henry	1967, 148
Killanin & Duignan	1967, 302
Conway	1975, 89-90, 125
Harbison	1975, 130

GRAIGUENAMANAGH II (South Cross, Aghailten Cross) Ch IX, Pl. 21

Graiguenamanagh, Kilkenny

S710437

Type of Monument: Cross

Present Location: Now erected in the graveyard at Duiske Abbey.

Evidence of Discovery: First mentioned 1857 when it had been inserted into the wall of the National School in the grounds of Duiske Abbey. It probably originated from Aghailten being moved to Graiguenamanagh by Rev. Braughal in the early nineteenth century. (Shearman 1874-5b).

Measurements:

H:	165 cm (65")
W of crosshead:	88 cm (34 $\frac{3}{4}$ "
<u>Shaft:</u>	H: 80 cm (31 $\frac{1}{2}$ "
	W: 41 < 42 cm (16 $\frac{3}{4}$ "
	D: 16 cm (6 $\frac{1}{4}$ "

Stone Type: Pale grey granite

Present Condition: The cross has been erected in a modern base. Part of the upper cross arm is missing. The carving is severely weathered.

Description: The crosshead is Type Ia(?). The wheel arcs and Faces B and D are undecorated.

Face A:

The crosshead and shaft have a perimeter roll moulding.

Crosshead:

The upper cross arm is divided horizontally into 2 panels.

- 1) Fragmentary interlace.
- 2) Interlace: 6 strand plait (St W: 2 cm).
- 3) In the centre of the crosshead, the Crucifixion partly framed by a roll moulding. Christ is shown face on and erect, clad in a loin cloth. He is beardless. His feet both point towards the right.

The shaft is divided into 2 panels.

- 4) Interlace: 2 separate lengths of Half B in 3 registers with bar terminals top and bottom (UM: 3 cm approx; St W: 2 cm approx).
- 5) As A 4 in 2 registers.

Face C:Crosshead:

- 1) In the centre the Crucifixion. Christ, a short stocky figure is shown face on and erect. He is beardless and has some kind of 'collar'. There are further traces of carving either side of His body below His arms. The ends of the horizontal cross arms are decorated with 1 unit of a closed circuit pattern of oval rings, RA No. 766.
- 2) On the upper cross arm 2 vertical rows of inward facing interlace loops.
- 3) The Shaft is undecorated.

Bibliography

O'Neill	1857, 3; Pl. 9
Shearman	1974-5b, 507
Crawford, H.S.	1907a, 223
Champneys	1910, 82, 87
Stokes, M.M.	1911, 120
Porter	1931, 27
Henry	1933, 206; Pl. 49.5
Henry	1940, 169, 173
Henry	1964, 25-6; 70
Killanin & Duignan	1967, 302
Conway	1975, 90 -1.
Harbison	1975, 130

KILKIERAN I (3 fragments, (a), (b), (c), (b) and (c) adjoining)

Castletown, Kilkenny.

Ch. V, Pl. 22.

S422271

Type of Monument: ShaftPresent Location: Kilkieran graveyard.Evidence of Discovery: First mentioned in 1905. Fragments (b) and (c) had been reused as the door lintel of the Osbourne Mausoleum.

Fragment a) seems to have been lying nearby. The lintel was removed in 1958 and the fragments reassembled.

Measurements:

	H:	57.5 cm	(22½")
(a)	W:	26 cm	(10¼")
	D:	22 cm	(8½")
	H:	89 cm	(35")
(b)	W:	18 cm	(7")
	D:	30 cm	(11¾")
	H:	52 cm	(20½")
(c)	W:	18 cm	(7")
	D:	33 cm	(13")

Stone Type: Mid grey sandstone.Present Condition: (a) has been broken across the top and bits are missing on Faces B and D. (b) and (c) have lost part of their width. The carving is badly weathered.Description: There is no surviving ornament on Faces B and D.Face A:

(a) Short lengths of vertical perimeter moulding are visible. The fragment is divided into 2 panels by a horizontal roll moulding. The area above the upper motif is undecorated.

- 1) Single unit of single Step Pattern outlined in relief with 4 auxiliary 'L' elements, one in each corner and a spiral in the centre.
- 2) Single unit of single Step Pattern recessed with a central square and 4 auxiliary 'L' elements outlined in relief.

(b) 3) Zoomorphic motif: 2 confronted serpents with gaping jaws,

the lower of which is forked. There is a round object suspended on a stalk between their jaws. Below this is a rectangular feature with a central vertical bar joined to each serpent. The lower part of the motif is lost.

4) Traces of a single unit of a swastica design.

There is no surviving ornament on the rest of the shaft.

Face B:

See Fig. 20.

Face C:

(a) There are traces of perimeter roll mouldings on the vertical sides. Spirals: a double border of 'C' scrolls in 6 registers with triangular expansions slashed with a triangular shape.

(b) There is a horizontal roll moulding across the bottom of the fragment. Spirals: as (a) in 6 registers with a single asymmetrical spiral at the bottom.

(c) No ornament.

Face D:

See Fig. 20.

Bibliography

Carrigan	1905, IV, 244
Crawford, H.S.	1907a, 244
Henry	1933, 208; Pl. 54.
Roe	1962, 34-5
Henry	1964, 67
Henry	1965, 139, 140, 154; Fig. 26; Pl. 78
Killanin & Duignan	1967, 144
Harbison	1975, 134

KILKIERAN II (West Cross)

Ch. V, Pl. 23

Castletown, Kilkenny.

S422271

Type of Monument: CrossPresent Location: Possibly in situ. It stands in the north west corner of the graveyard at Kilkieran.Evidence of Discovery: First mentioned 1851 when the crosshead was being used as a gravestone. The monument was reassembled in 1858.Measurements:

H:		385 cm (150") approx.
W of Crosshead:		108 cm (42½")
<u>Shaft:</u>	H:	125 cm (49¼")
	W:	41 > 37 cm (16¼" > 14½")
	D:	37 > 30 cm (14½" > 11¾")
<u>Base:</u>	H:	66 cm (26")
	W:	115 > 76 cm (45¼" > 30")
	D:	108 > 64.5 cm (42½" > 25¼")

Stone Type: Fine pale grey sandstone.Present Condition: The 2 fragments have been clumsily joined with cement. Most of the carving is well preserved. Some of the perimeter mouldings are missing.Description: The crosshead is Type II and it is surmounted by a conical capstone. The shaft has a butt. The crosshead and shaft are surrounded by perimeter rope mouldings and the decorated panels are correspondingly recessed. The base is shaped like a truncated pyramid with 3 steps, the upper 2 shallow, the lowest deep. The top step is sloping rather than flat.Face A:

1) The crosshead and upper part of the shaft are decorated as a single unit. There are railhead bosses in the centre of the crosshead, on the crossarms and at the top of the shaft. The background is decorated with a plaitwork mesh (UM and St W: variable).

The wheel arcs are decorated with interlace: 2 strand twist.

The rest of the shaft is divided into 2 panels framed by rope mouldings.

- 2) Spirals: A double (?) border pattern (type unknown) in 3 registers.
- 3) Zoomorphic Motif of 4 bird-like creatures in 2 groups of 2. Each pair are confronted, their necks crossed. They have long snouts or beaks, the upper longer than the lower, and one front leg. Their bodies curl upwards and then spiral into a hip joint with a stubby tail and hind leg. There is a cross shape in relief in the centre.
- 4) Butt: No ornament.

Base:

- 5) Top Step: No surviving ornament.
- 6) Middle Step: Interlace: Simple F elements placed horizontally and linked by long glides.

The Bottom Step is divided vertically into 3 panels framed by rope mouldings.

- 7) Left: Interlace: 12 strand plait (Diag. UM: 4 cm approx; St W: 1.5 cm).
- 8) Centre: Spirals: a combined square panel pattern with plain triangular expansions.
- 9) Right: Interlace: 3 vertical lengths of 6 strand plait linked top and bottom (Diag UM: 3 cm approx, St W: 1.5 cm).

Face B:

- 1) The upper cross arm is divided vertically into 3 by rope mouldings. Interlace: the outer panels 2 strand twist, the central 4 strand plait.
- 2) The upper wheel arc is faceted forming 2 long thin rectangular panels. They are decorated with 2 strand twist.
- 3) The panel at the end of the horizontal cross arm is formed by a rope moulding. It is decorated with a grid of horizontal, vertical and diagonal lines forming cut out triangles.
- 4) Lower wheel arc: As B 2.
- 5) The Shaft is divided vertically into 3 by rope mouldings. Interlace: the outer panels 2 strand twist (Diag. UM: 3 cm; St W: 1.5 cm), the central 4 strand plait (Diag UM: 4.5 cm; St W: 1.5 cm).
- 6) Butt: No ornament.

Base:

- 7) Top Step: No surviving ornament.
- 8) Middle Step: Interlace: short lengths of 6 strand plait separated by long glides (Diag UM: 1.5 cm; St. W: 1 cm).

The Bottom Step is divided vertically into 2 panels framed by rope mouldings.

- 9) Left: Interlace: Closed Circuit Patterns in 2 registers. The upper, 3 units of 4 petal marigold, each entwined with a circle. Below 2 5 petal marigolds entwined in circles linked by strands which form a 6 strand plait in the centre.
- 10) Right: Interlace: 22 strand plait with several breaks in the bottom right hand corner of the panel.

Face C:

- 1) The crosshead and upper part of the shaft are decorated as a single unit. Domed bosses placed as A 1. The background is decorated with interlace: 2, 4 and 8 strand plait (UM and St W: variable).

The wheel arcs as A 1.

The rest of the shaft is divided into 2 panels framed by rope mouldings.

- 2) As A 2.
- 3) Interlace: 16 strand plait (Diag UM: 2.25 < 3 cm approx; St W: 1 cm).
- 4) Butt: No ornament.

Base:

There is no surviving ornament on the top 2 steps. The bottom step is divided vertically by rope mouldings into 2 panels.

- 5) Left: 4 horsemen in 2 registers of 2 shown in profile facing right. The riders are small projections from the horses' backs. The reins are visible.
- 6) Right: As C 5 except the horseman in the bottom right hand corner is shown in profile facing left.

Face D:

- 1) The upper cross arm: As B 1.
- 2) The upper wheel arc: As B 2.

3) The panel at the end of the horizontal cross arm is framed by a rope moulding. It is decorated with interlace: 6 strand plait.

4) The lower wheel arc: As B 2.

5) The Shaft is divided vertically into 3 by rope mouldings. The surviving outer panel (left) is decorated with interlace: 2 strand twist (Diag UM: 2 cm; St W: .75 < 1 cm), the central with an adaptation of 6 strand plait.

6) Butt: No ornament.

Base:

7) Top Step: No surviving ornament.

8) Middle Step: Traces of interlace units joined by long glides.

The Bottom Step is divided vertically into 2 panels framed by rope mouldings.

9) Left: Interlace: 22 strand plait with breaks in the centre forming a cruciform shape (Diag. UM: 3 cm; St W: 1.5 cm).

10) Right: Interlace: a variety of plaits: 6, 8, 10 and 12 (?) strand. (UM and St W: variable).

Bibliography

Blackett	1851, 487-8.
O'Neill	1857, 10; Pl XXVII
Keane	1867, 424
Carrigan	1905, IV, 243.
Power	1906, 8-9
Crawford, H.S.	1907a, 224
Crawford, H.S.	1909c.
Champneys	1910, 73, 92; Pl XLII
Crawford, H.S.	1926a, Nos 29, 30, 32, 35; Figs 4B, 5B.
Henry	1930a, 95, 102
Porter	1931, 23, 112; Figs. 20, 185
Henry	1933, 50, 97, 98, 100, 106, 123, 164, 165; Fig. 69; Pls, 24-6, 32, 41.
Henry	1940, 85, 103, 105, 106
Sexton	1946, 7-8
Roe	1962, 37-41

Henry	1964, 21-4
Henry	1965, 139, 140, 154; Fig. 26; Pl. 78.
Killanin & Duignan	1967, 144.
Harbison	1975, 134.

KILKIERAN III (East Cross)

Ch. V, Pl. 24

Castletown, Kilkenny

S422271

Type of Monument: Cross

Present Location: Possibly in situ. It stands in the graveyard at Kilkieran to the south east of the Mausoleum. (It is on a different alignment from Kilkieran II).

Evidence of Discovery: First mentioned 1851 when it was 'broken and prostrate'. It was reassembled in 1858.

Measurements:

H:		269 cm (106½")
W of crosshead:		94 cm (37")
<u>Shaft:</u>	H:	111 cm (43¾")
	W:	33 > 28 cm (13" > 11")
	D:	26.5 > 24 cm (10½" > 9½")
<u>Base:</u>	H:	45.5 cm(18")
	W:	91 > 68 cm (35¾" > 26¾")
	D:	90 > 66 cm (35½" > 26")

Stone Type: Fine mid grey sandstonePresent Condition: Good.

Description: The crosshead is Type II with a conical capstone the rim of which is marked by a groove. The shaft and crosshead have flat perimeter mouldings. The Base is the shape of a truncated pyramid, the angle of incline changing part way up. The cross is undecorated apart from a nailhead boss placed at the centre of the crosshead on each broad face (A & C).

Bibliography

Blackett	1851, 487-8
O'Neill	1857, Pl XXVII
Carrigan	1905, IV, 243
Power	1906, 8
Crawford, H.S.	1907a, 224
Crawford, H.S.	1909c, 256
Porter	1931, 23, 112; Fig. 184

Henry	1933, 208; Pl. 24.
Henry	1940, 103
Roe	1962, 36-7.
Henry	1964, 67
Killanin & Duignan	1967, 144.
Harbison	1975, 134.

KILKIERAN IV

Ch XI, Pl 25

Castletown, Kilkenny

S422721

Type of Monument: CrossPresent Location: Probably in situ. It stands in the graveyard at Kilkieran to the east of the Osbourne Mausoleum.Evidence of Discovery: First mentioned 1851.Measurements:

H: 339 cm (133½")
 W of crosshead: 43 cm (17")
Shaft: H: 192 cm (75½")
 W: 27 > 20 cm (10½" > 8")
 D: 23.5 > 19 cm (9¼" > 7½")
Base: H: 21 cm (8¼")
 Diam: 87 cm (34¼") approx.

Stone Type: Fine mid grey sandstonePresent Condition: The carving is severely weathered.Description: The crosshead type is unclassifiable being tall, thin and wheel-less with short, horizontal cross arms. The tall upper cross arm is surmounted by a tenon. The cross has perimeter rope mouldings which taper towards the top. All the carving is in very low relief. The cross is set in a circular undecorated base with 2 steps.Face A:

Above and below the horizontal cross arms are a pair of shallow half circular insets. In the centre of the crosshead is a recessed roundel surrounded by a roll moulding. There is a shallow groove along the top and towards the end of both horizontal cross arms.

On the shaft there are traces of incised horizontal lines indicating flat double mouldings which divide it into 4(?) panels. The lowest of these contains a long, slightly recessed panel which is concave at the bottom. At the bottom of the shaft is a fifth (?) panel defined by a horizontal roll moulding.

Face B:

On the left hand side are 2 half circular insets, one above and one

below the horizontal cross arm. The upper cross arm has a concave face. At the end of the horizontal cross arm is a square recessed panel.

Face C:

The centre of the crosshead is outlined by flat mouldings forming a square. There are traces of ornament on the horizontal cross arms. The shaft is divided into 5 panels by flat, horizontal mouldings. On the second panel down there are traces of a Greek cross delineated by incised lines. The fourth panel is partly recessed.

Face D:

As B except the half circular insets are on the right hand side.

Bibliography

Blackett	1851, 487.
Carrigan	1905, IV, 243
Power	1906, 7-8
Crawford, H.S.	1907a, 224
Crawford, H.S.	1909c, 256
Porter	1931, 112; Fig. 179
Roe	1962, 35-7
Henry	1964, 67
Killanin & Duignan	1967, 144
Harbison	1975, 134

KILLAMERY (Killamery)

Ch VI, Pl 26

Killamery, Kilkenny



S377360.

Type of Monument: CrossPresent Location: Probably in situ. It stands in the graveyard to the north of the church.Evidence of Discovery: First mentioned 1839 (O'Donovan 1928b, 98).Measurements:

H:		315 cm (175")
W of crosshead:		113 cm (44½")
<u>Shaft:</u>	H:	110.5 cm (43½")
	W:	44 > 39.5 cm (17¼" > 15½")
	D:	36 > 32 cm (14¼" > 12½")
<u>Base:</u>	H:	60 cm (23½")
	W:	123 > 84 cm (48½" > 33")
	D:	123 > 78 cm (48½" > 30½")

Stone Type: Pale grey sandstone.Present Condition: Much of the carving is badly weathered.Description: The crosshead is Type I. It has a roof shaped capstone which is crenellated on Face C. The shaft has a butt. The shaft and crosshead have perimeter rope mouldings hatched with a herring bone pattern. The base, shaped like a truncated pyramid, has 2 steps, the lower being uneven due to a fault in the stone.Face A:Crosshead:

- 1) The upper cross arm is decorated with a single step pattern (UM: 2.5 cm), 7 registers, 3 units abreast.
- 2) On the narrow part at the bottom of the upper cross arm are 2 figures shown in profile facing each other. The right hand figure holds an upright spear (?) whilst the left has a round shield. The left hand figure has his right foot raised.
- 3) The raised central roundel (diam: 25 cm), surrounded by a roll moulding, is decorated with a 3 terminal spiral; each terminal has a median groove.

- 4) On the left horizontal cross arm is a hunting scene. On the left hand side is a horseman shown in profile facing right. He pursues a stag. Other traces of carving above and below the stag may be hounds.
- 5) On the right horizontal cross arm is a procession shown in profile moving from right to left led by a figure holding a staff. A horseman carrying a crozier leads a chariot with traces of passengers. Below the horseman is a quadruped.
- 6), 7), 8) Wheelarcs: No surviving ornament.
- 9) Shaft: This is divided into 3 panels separated by double incised lines.
- 10) The Crucifixion: Christ is shown face on, His body erect. He has short hair and is clad in a long robe or tunic with traces of drapery folds round the neck. To either side are 2 figures who hold a circular disc over Christ's head.
- 11) Frets: A carpet of interlocking  elements with auxiliary T elements placed top and bottom as fillers (Diag UM: 7.5 cm).
- 12) Frets: A carpet of interlocking  elements with each terminating top and bottom with a straight line spiral (Diag. UM: 7.5 cm).
- 13) On the butt are traces of an inscription carved in relief.

Base:

- 14) On the upper step spirals: Double border pattern in 3 registers joined by 'S' scrolls. The spirals are raised into nailhead bosses and the expansions have spiral curlicues.
- 15) On the lower step a variety of abstract ornament. Left to right:-
 (i) Plaitwork (?); (ii) interlace: a square with incised diagonals containing 4 Simple E elements; (iii) a chequer pattern forming a double cruciform shape in relief, each of the raised squares being filled with a spiral; (iv) ?; (v) as (ii).

Face B:

The upper cross arm, the wheel arcs and the shaft are divided vertically by rope mouldings into 3 panels.

Crosshead:

- 1) On the upper cross arm the central panel has a 2 strand twist (St W: 4 cm). There is no surviving ornament on the outer panels.

2) Upper Wheel Arc: No surviving ornament.

The end of the horizontal cross arm is divided horizontally into 2 panels.

3) The upper: 2 horsemen (?) shown in profile facing left.

4) The lower: A boat with 4 figures in it.

5) The lower wheel arc: only the central panel is decorated with a single border of 'S' scrolls.

6) Shaft: Only the central panel is decorated with 2 strand twist (UM: 5 cm).

7) On the butt a flat roundel with traces of interlace.

Base:

8) On the upper step: Double step pattern, 3 units, each marked with a square grid forming a cruciform shape in the centre. The background is decorated with triangular areas of plaitwork.

9) On the lower step: no surviving ornament.

Face C:

1) The crosshead and upper part of the shaft are decorated as a single unit. Zoomorphic ornament: on each horizontal cross arm are 2 dragonsque beasts locked in combat. Their serpentine bodies either curl downwards to bifurcate and then form an 8 strand plait at the top of the shaft or curl upwards to form a double spiral on the upper cross arm. Each beast is shown in profile. It has gaping jaws with sharp teeth. The upper jaw is curled and an incised line outlines both jaws. It has a large almond shaped eye. The neck is decorated with herringbone hatching. In the centre of the crosshead is a boss (Diam: 20 cm) surrounded by a roll moulding and decorated with an incised spiral. The sides of the boss are hatched vertically. On the upper cross arm is a splayed dragonsque quadruped with goggle eyes and gaping jaws with curled ends and jagged teeth. The backbone is indicated with incised lines and it has a short tail.

2), 3), 4), 5) Wheel arcs: Traces of interlace ornament.

6) The lower part of shaft is decorated with interlace: 3 units of 4 petal marigold, the background being filled with a variety of ornament: Simple E elements, triangles and diamond shapes.

7) Butt: No ornament.

Base:

8) On the upper step a single step pattern 4 units abreast. Each has an incised Greek cross with expanded terminals in the centre.

9) On the lower step a single step pattern in 2 registers (UM: 2.5 cm).

Face D:

The upper cross, the wheel arcs and the shaft are divided vertically by rope mouldings into 3 panels.

Crosshead:

1) Upper cross arm: As B 1.

2) Upper wheel arc: No surviving ornament.

The end of the horizontal cross arm is divided into 4.

3) Top Left: Jacob and the Angel: 2 confronted figures wrestling.

4) Top Right: On the left is a figure shown upside down. He wears a helmet and carries a round shield. On the right David breaking the jaws of the lion. David clad in a tunic has his right arm raised to strike a small lion which leaps up at him. His left arm is stretched towards the beast's mouth.

5) Bottom Left: Anthropomorphic interlace (?). Two figures shown in profile facing each other with interlaced (?) forelocks and a rectangular object placed between them.

6) Bottom Right: 2 figures shown face on dressed in tunics.

7) The lower wheel arc: only the central panel is decorated.

Interlace: 4 strand plait (St W: 3 cm).

8) Shaft: Only the central panel is decorated with interlace: a variation of Simple F terminating in a Simple E element (UM: 5 cm; St W: 3.5 cm).

9) Butt: No ornament.

Base:

10) Upper step: No surviving ornament.

11) On the lower step bands of plaitwork separated by recessed Z shapes, the raised borders of which are decorated with a plaitwork (?) mesh.

Bibliography

- O'Neill 1857, 1, 3; Pls 1, 2, 8.
- Keane 1867, 63, 424; Fig. 50.
- Petrie 1878, II, 24
- Allen 1887, 134
- Stokes, M.M. 1898, v
- Stokes, M.M. 1901, 567, 572-8; Pls XLVI-LI
- Carrigan 1905, IV, 311-8
- Power 1906, 13-17
- Crawford, H.S. 1907a, 223
- Crawford, H.S. 1909c, 256
- Champneys 1910, 73, 94, 95
- Stokes, M.M. 1911, 119
- Crawford, H.S. 1926a, Nos. 27, 61, 96; Figs 2C, 9H.
- O'Donovan 1928b, II, 98
- Henry 1930a, 96, 102
- Porter 1931, 13; Fig. 189
- Henry 1933, 53, 55, 79, 80, 98, 104, 107, 117, 132, 133, 134, 145, 164, 165; Figs. 72, 89; Pls 27, 31, 37.
- Henry 1940, 102, 105, 111
- Sexton 1946, 198-201
- Macalister 1949, 25
- Roe 1949, 44
- De Paor, M. & L. 1960, 126
- Roe 1962, 42-8
- Henry 1964, 22-4; Pl. 7
- Henry 1965, 139, 141, 142, 147, 148, 149, 154, 156; Pl 67
- Killanin & Duignan 1967, 134
- Harbison 1975, 136.

KILREE (Kilrea; Kilrigh)

Ch VI; P1 27

Kilree, Kilkenny

S499280

Type of Monument: CrossPresent Location: Probably in situ. It stands in a field 50 meters (approx.) west of the church and round tower.Evidence of Discovery: First mentioned 1839 (O'Donovan 1928b, II, 68).Measurements:

H:		281 cm (111")
W of crosshead:		110 cm (43½")
<u>Shaft:</u>	H:	104 cm (41")
	W:	46 > 42.5 cm (18" > 16¾")
	D:	36.5 > 35 cm (14¼" > 13¾")
<u>Base:</u>	H:	50 cm (19¾")
	W:	105 > 83 cm (41½" > 32½")
	D:	Face B: 103 > 67 cm (40½" > 26½")
		Face D: 111 > 75 cm (44" > 29½")

Stone Type: Mid grey sandstone.Present Condition: The carving is severely weathered. The capstone is missing.Description: The crosshead is Type I. There is a tenon on the upper cross arm (H: 12cm; W: 17cm; D: 11cm). The shaft has a butt. The crosshead and shaft have perimeter roll mouldings. The base is shaped like a truncated pyramid with 2 steps of uneven dimensions.Face A:

1) Crosshead: There are bosses in the centre of the crosshead, on each of the crossarms (and at the top of the shaft). The central boss is enclosed in a roundel framed by a roll moulding (Diam: 45cm approx). decorated with interlace: 6 strand plait (St W: 1.5cm). A hairspring spiral emanates from each of the bosses on the crossarms, that on the upper cross arm forming an 'S' scroll terminating in a bird's head.

2), 3), 4), 5) Wheelarcs: Traces of plaitwork.

Shaft:

6) A figure shown face on and crouching, dressed in a long robe, his

right arm raised. On either side is a quadruped shown in profile facing him. They have squared gaping jaws and traces of long tails terminating in tufts.

7) 5 Roundels delineated by slashed triangular shapes.

8) Chequer-board (?) pattern.

9), 10) Base: No surviving ornament.

Face B:

The upper cross arm, wheel arcs and shaft are divided vertically into 3 panels by roll mouldings.

Crosshead:

1) Upper cross arm: No surviving ornament.

2) Upper wheel arc: No surviving ornament.

3) The panel at the end of the horizontal cross arm: traces of fret ornament.

4) Under the horizontal cross arm and continued along the central panel of the lower wheelarc: 6 strand plait (Diag UM: 2.5cm; St W: 1.5cm). The outer panels are undecorated.

5) Shaft: central panel: Changing Interlace: An interlocking pattern (RA No. 573), a variation of element F in 6 registers, 6 strand plait. On the left are frets: a vertical row of simple ↗ elements, on the right spirals: a single border of 'S' scrolls.

Base:

6) On the upper step a chequer board pattern forming cruciform shapes.

7) On the lower step: no surviving ornament.

Face C:

Crosshead:

1) Upper cross arm: Single step pattern in $5\frac{1}{2}$ registers with a square cut out in the centre of each unit (UM: 2.5 cm).

2) In the centre of the crosshead, a boss (Diam. 15cm) surrounded by a roundel (Diam. 45cm approx) decorated with Interlace: Simple F (St W: 3cm). The roundel is framed by a roll moulding.

3) On the left horizontal cross arm: Traces of a hunting scene in 2

registers. On the top are 2 horsemen shown in profile facing right.

4) On the right horizontal cross arm: Traces of a hunting scene. There is a horseman shown in profile facing right in the upper centre of the panel and 2 hounds (?) shown in profile facing right, are placed above the other in the bottom right hand corner.

5), 6), 7), 8) Wheelarcs: Traces of plaitwork.

Shaft:

9) Frets: A carpet of interlocking [elements with straight line spiral terminals.

10) Frets: A carpet of interlocking ↗ and Z elements (Diag. UM: 9 cm).

Base:

11) Upper step: No surviving ornament.

12) Lower step; Frets: horizontal row of Simple Z elements.

Face D:

The upper cross arm, wheel arcs and shaft are divided vertically into 3 panels by roll mouldings.

Crosshead:

1) Upper cross arm: No surviving ornament.

2) Upper wheel arc: No surviving ornament.

The panel at the end of the horizontal cross arm is divided into 4 by roll mouldings with a circular feature in the centre.

3) Top left: a figure shown in profile facing right in front of a quadruped. There is a crescent shape above the figure's head.

4) Top right: A fantastic beast shown in profile facing right. A quadruped with a feline body, human (?) head and floriate tail.

5) Bottom left: Jacob and the Angel. 2 confronted wrestling figures.

6) Bottom right: 3 figures. The central figure is face on with his arms stretched in the air.

7) The lower wheel arc and shaft: The central panel is decorated with changing frets: a border of Z elements with auxiliary ↗ elements, ↘ elements with auxiliary T elements (Diag UM: 7.5 cm). On the left: no surviving ornament. On the right: 4 strand plait with glides (St W: 2cm).

Base:

- 8) Upper step: 3 units of double step pattern with a cruciform cut out in the centre of each unit.
- 9) A horizontal row of parallel diagonal bars in relief.

Bibliography

Clark	1903
Carrigan	1905, IV, 50
Crawford, H.S.	1907a, 223
O'Donovan	1928b, II, 68
Henry	1930a, 96, 102
Henry	1933, 104, 107, 117, 122, 132, 133, 134, 164, 165; Figs. 90, 97; Pls 38, 30-2.
Henry	1940, 102, 105, 108
Sexton	1946, 208-9
De Paor, M & L	1960, 126
Roe	1962, 49-53
Henry	1964, 22-4; Pl 9
Henry	1965, 100, 139, 141, 147, 154; Pls 75, 96, 106.
Evans	1966, 139
Harbison	1975, 137
Lahert	N.D. 32-6

KINNITTY I (Cenn-Etig)

Ch VIII, P1 28

Castletown and Glinsk, Offaly.

N 197055

Type of Monument: CrossPresent Location: It is situated in the grounds of the Forestry College, Castle Bernard, Kinnitty.Evidence of Discovery: First mentioned 1898. Some time before this it had been found near Kinnitty (no precise location given) and taken to Castle Bernard (Purser 1918, 74).Measurements:

H:		208 cm (82")
W of crosshead:		Unknown
<u>Shaft:</u>	W:	45 > 43 cm (17 $\frac{3}{4}$ " > 17")
	D:	13 < 18 cm (5" < 7")

Stone Type: Fine yellow ochre sandstone with a considerable quantity of grit.Present Condition: The cross is mounted in a crossbase (Kinnitty II). The crosshead is badly damaged, the wheel arcs having been lost completely and the majority of the crossarms although some reconstruction of these has been attempted with modern concrete. The house-shaped capstone has been lost since 1933 (Henry 1933, P1 92). Some of the carving on Faces B and D is badly weathered.Description: The crosshead type is unknown. The shaft tapers considerably on the narrow faces and it has a butt at the bottom. The shaft and crosshead are surrounded by perimeter roll mouldings. The decorated panels are framed by roll mouldings with vertical breaks.Face A:

1) Crosshead: The surviving area shows the Crucifixion. Christ is shown face on, His body erect, His head tipped slightly down towards the left. He is beardless, has short curly hair and is perhaps naked. His feet, which point outwards, are bound and rest on a narrow suppedaneum. To Christ's left is the spongebearer, a small figure shown in profile facing right with long curls of hair. His right leg is sharply flexed. He holds a cup on a rod to Christ's mouth. The spear tip of the spearbearer, now lost, may be discerned beneath Christ's armpit on the other side.

There are traces of further carving on the upper cross arm.

The shaft is divided into 3 panels.

- 2) Interlace: Encircled and Turned D in 2 registers of 2 units (UM: 2 cm; St W: 1.5 cm). Simple E elements have been inserted as fillers at the top and bottom of the pattern.
- 3) Two figures. The left hand figure is shown seated on an 'L' shaped chair with a low back and short legs. He is shown in profile facing right and is dressed in a long robe. A lyre rests on his knee. Above his head is a bird shown in profile facing left, its head turned towards its tail. The right hand figure is shown in profile facing left and standing. He is dressed in a long robe with an overgarment with a hood (?). In his left hand he holds a crozier; in his right he raises aloft a rectangular object with a handle.
- 4) Interlace: Double stranded Basic A in 2 registers (UM: 2 cm; St W: 1.5 cm).
- 5) On the butt a fragmentary inscription in 2 registers.

Face B:

Crosshead: No surviving ornament.

The Shaft is divided into 4 panels.

- 1) Anthropomorphic ornament: The upper halves of 2 face on figures with raised arms curl into a central boss.
- 2) Zoomorphic interlace: Half B in 2 registers with an additional loop at the top and bottom (UM: 2 cm approx; St W: 1.5 cm). The pattern at the top terminates with a dragonsque head shown in profile facing right, at the bottom with a triangular fish tail crossed by a loose strand.
- 3) Spirals: A single border pattern of 'S' scrolls in 5 registers with triangular expansions.
- 4) Plaitwork Mesh

Face C:

Crosshead:

- 1) In the centre is a square panel framed by a roll moulding. Within this is a bossed spiral roundel. The 6 outer spirals are joined to each other by 'S' scrolls; alternate spirals are joined to the central spiral

by 'C' scrolls. The spirals have triangular expansions. The area between the square frame and the roundel is filled with interlace strands.

2), 3), 4) Traces of interlace on the upper and horizontal cross arms, the strands terminating in serpentine heads (?).

5) On the lower cross arm 2 confronted birds, their legs interlaced, their necks entwined in a Simple F knot. They have small triangular crests and their wings are decorated with spiral ornament.

The Shaft is divided into 4 panels.

6) The Fall: Adam on the left and Eve on the right are shown facing each other either side of the Tree. They each hold out a hand and grasp the Apple. Adam is bearded. The Tree divides into 2 branches above their heads. The branches are decorated with round vegetation buds.

7) Zoomorphic Interlace: Basic A Turned and placed on the diagonal in 2 registers with a quadrilobate motif in the centre. The pattern is framed by 4 dog-like quadrupeds whose tails are extended to form the interlace strands. The right hind leg of each beast is extended to form the diagonal strand across each interlace loop.

8) Spirals: Bossed spirals in 3 registers of 3 joined by 'C' scrolls. There are traces of slash marks on the triangular expansions.

9) Interlace: Double Stranded Half B in 2 registers turned through 90° (UM: 2 cm; St W: 1 < 1.5 cm).

10) There are traces of horizontal incised lines along the top and bottom of the butt.

Face D:

Crosshead: No surviving ornament.

The Shaft is divided into 4 panels.

1) Interlace: Basic C Turned in 2½ registers with bar terminals top and bottom (UM: 2 cm; St W: 1.5 cm).

2) Spirals: Single border of 4 spirals joined by 'S' scrolls. The corners of the panel and the expansions are lengthened into curlicues.

3) Interlace: Simple B in 2 registers (UM: 2 cm; St W: 1.5 cm) degenerating into a mass of interlace strands terminating in a Half B element.

4) Square fret pattern: a single \square element with straight line spiral terminals.

Bibliography

Stokes, M.M.	1898, iv
Crawford, H.S.	1907a, 225
Gleeson, J.	1915, 546
Purser	1918, 74
Crawford, H.S.	1926a, Nos 3, 40, 88; Figs 2B, 3B, 12A
Henry	1933, 54, 66, 98, 137; Pls 55, 92
Sexton	1946, 210-1
Roe	1949, 41-2
Henry	1964, 16
Roe	1965, 215
Killanin & Duignan	1967, 341-2
Harbison	1975, 201
Cunningham	1976, 56

KINNITTY II (Cenn-Etig)

Ch VIII, P1 29

Castletown and Glinsk, Offaly

N197055

Type of Monument: Cross-BasePresent Location: Situated in the grounds of the Forestry College, Castle Bernard, Kinnitty.Evidence of Discovery: First mentioned 1907. Some time before this it had been found near Kinnitty (no precise location given) and taken to Castle Bernard (Purser 1918, 74).Measurements:

H: 85 cm (33½")
 W: 98 > 69 cm (38½" > 27¼")
 D: 72 > 50 cm (28¼" > 19¾")

Stone Type: Mid grey limestonePresent Condition: Much of the base, particularly Face B, has been restored with concrete. Kinnitty I is mounted in the base.Description: It is shaped like a truncated pyramid. The decoration on all 4 faces is the same consisting of 2 horizontal bands demarkated by roll mouldings decorated with interlace: the upper Half B and the lower 4 strand plait (UM: 3 cm; St W: 2 cm).Bibliography

Nothing specific.

LEGGETTSRATH I

Ch XI, P1 30

Leggettsrath East, Kilkenny

S535559

Type of Monument: ShaftPresent Location: It is situated in the centre of a rath in 'The Church Field'.Evidence of Discovery: First mentioned 1874-5.Measurements:

H above MGS:	117 cm (48")
Above projection H:	45 cm (18")
W:	39 > 36 cm (15½" > 14")
D:	30 > 28 cm (12" > 11")
Below projection W:	49 > 47 cm (19¼" > 18½")
D:	24 < 33 cm (9½" < 13")

Stone Type: Pale pink granitePresent Condition: The shaft is broken across the top. The carving is severely weathered.Description: The shaft is divided horizontally into 2 parts by a slight projection. The upper shows traces of a socket in the top (W: 24cm ; D: 16 cm). The upper half has perimeter roll mouldings on Faces A, B and D.Face A (South Face)

The panel on the upper half is slightly recessed. There are no traces of ornament. The projection at the top of the lower half is defined by a horizontal roll moulding.

Face B (East Face)

On the upper half: a recessed Latin cross.

Face C: (North Face)

Undecorated.

Face D: (West Face)

The panel on the upper half is slightly recessed and decorated with a chequer board pattern in 5 registers.

Bibliography

Shearman	1874-5a, 396-7
Carrigan	1905, III, 266-7
Henry	1964, 68
Prendergast	1964
Killanin & Duignan	1967, 326

LEGGETTSRATH II

Ch XI, Pl 31

Leggettsrath East, Kilkenny

S535559

Type of Monument: CrossheadPresent Location: Adjacent to Leggettsrath I in the centre of a rath in 'The Church Field'.Evidence of Discovery: Found in the winter of 1963 by Rev. J. Clohosey and Margaret Phelan during a Kilkenny Archaeological Society visit. In Spring 1963 the fragment was completely uncovered by Eoin O'Ceallaigh (Prendergast 1964, 7).Measurements:

H: 48 cm (19")

W: 68 cm (27")

D: 18 cm (7")

W of crosshead (reconstructed): 80 cm (32") approx.

Present Condition: Two wheel arcs and one complete cross arm are missing. It is impossible to view faces B, C and D as the fragment is partially buried in vegetation.Description:

The crosshead is Type Ib(?).

Face A:

There are traces of perimeter roll mouldings. In the centre is a boss framed by traces of a roll moulding.

Face C:

Following Prendergast's description (1964, 8) the face has a small central boss but is otherwise undecorated.

Bibliography

Prendergast

1964

LORRHA I (West Cross)

Ch V, Pl 32

Lorrha, Tipperary

M915044

Type of Monument: Cross-base and shaft.Present Location: Probably in situ. It stands on the western edge of the modern graveyard at the Franciscan friary of St. Ruadan.Evidence of Discovery: First mentioned 1909.Measurements:

<u>Shaft:</u>	H:	61 cm (24")
	W:	40 cm (16")
	D:	30 cm (11 $\frac{3}{4}$ ")
<u>Base:</u>	H:	99 cm (39")
	W:	115 > 63 cm (45 $\frac{1}{4}$ " > 25")
	D:	87 > 54 cm (34 $\frac{1}{2}$ " > 21 $\frac{1}{2}$ ")

Stone Type: Yellow ochre sandstone.Present Condition: The shaft has been broken at the top. The carvings are severely weathered and obscured by lichen.Description: The shaft has traces of perimeter roll mouldings and a butt. The shaft panels on faces B and D are recessed.

The base is shaped like a truncated pyramid with 3 steps, the upper 2 shallow, the lowest deep. The top step is sloping rather than flat. The base panels are framed by rope mouldings.

Face A:Shaft: No surviving ornament.Base:

- 1) Top Step: No surviving ornament.
- 2) Middle Step: A procession of 7 horses shown in profile facing left, their heads lowered.

The Bottom Step is divided vertically into 3 panels.

- 3) Left: Interlace: 16 strand plait with breaks across the centre of the pattern (Diag UM: 3 cm; St W: 1.5 cm).
- 4) Centre: Spirals: Adaptation of a roundel to a square panel. A central spiral with 9 outer spirals. It is unknown how they are joined.

5) Right: Grid of diagonal, horizontal and vertical lines (?).

Face B:

Shaft: No surviving ornament.

Base:

- 1) Top Step: No surviving ornament.
- 2) Middle Step: Traces of a procession of 6 horses shown in profile facing left.

The Bottom Step is divided vertically into 2 panels.

- 3) Left: No surviving ornament.
- 4) Right: Traces of plaitwork.

Face C:

Shaft: No surviving ornament.

Base:

- 1) Top Step: No surviving ornament.
- 2) Middle Step: Traces of a procession of horses.

The Bottom Step is divided horizontally into 2 but not separated by mouldings.

- 3) Top: Plaitwork (?).
- 4) Bottom left: 3 lion-like quadrupeds. The 2 on the left face each other and have square gaping jaws. The third is shown in profile facing right, its left legs raised in motion. It has a square face, gaping jaws, a feline ear and almond shaped eye. It faces a human figure (?).
- 5) Bottom right: Chequer board pattern forming cruciform shape with recessed squares in the centres.

Face D:

- 1) Shaft: 6 (?) strand plait.

Base:

- 2) Top Step: Traces of a procession of horses.
- 3) Middle Step: A procession of 5 horses shown in profile facing left.
- 4) Bottom Step: Traces of plaitwork.

Bibliography

- | | |
|--------------------|--|
| Crawford, H.S. | 1909b |
| Champneys | 1910, 93; P1 XLI |
| Gleeson, J. | 1915, 244-5 |
| Crawford, H.S. | 1918, 176 |
| Henry | 1933, 50, 97, 117, 123, 164; Fig 88; P1 26 |
| Henry | 1940, 102, 103, 105, 106 |
| Sexton | 1946, 214-5 |
| Roe | 1962, 9 |
| Henry | 1964, 22-4, 68 |
| Henry | 1965, 138, 139, 141, 147, 154; P1 86 |
| Killanin & Duignan | 1967, 359 |
| Harbison | 1975, 231 |

LORRHA II (East Cross)

Ch V, Pl 33

Lorrha, Tipperary

M915044

Type of Monument: Cross-base and shaft.Present Location: Probably in situ. It stands immediately to the South West of the Church of St Ruadan in the graveyard of the Franciscan Friary.Evidence of Discovery: First mentioned 1909.Measurements:

H:		162 cm (64")
<u>Shaft:</u>	W:	37 cm (14½")
	D:	30 cm (13")
<u>Base:</u>	H:	53 cm (21")
	W:	153 > 106 cm (60" > 42") approx.
	D:	143 > 84 cm (56½" > 33") approx.

Stone Type: Yellow ochre sandstone.Present Condition: The shaft has been broken at the top. The surviving carving is fragmentary and partially obscured by lichen.Description: The shaft has a butt. The panels on Faces B and D are recessed and framed by roll mouldings and there are indications of perimeter roll mouldings. The panels on Faces A and C are separated by horizontal incised lines.The base is very roughly shaped into a truncated pyramid with 2 steps, the upper shallow, the lower deeper. No apparent ornament.Face A:

- 1) Shaft: Traces of 12 strand plait (Diag. UM: 4.5 cm; St W: 1.5 cm)

Face B:

- 1) Shaft: 6 strand plait (Diag UM: 4.5 cm; St W: 1.5 cm).

Face C:The Shaft is divided into 2 panels.

- 1) Plaitwork frame with a central inset containing 2 units of a Closed Circuit pattern of oval rings (RA No. 766) in 4 registers.
- 2) 12 strand plait (Diag UM: 4.5 cm; St W: 1.5 cm).

Bibliography

Crawford, H.S.	1909b
Gleeson, J.	1915, 244-5
Crawford, H.S.	1918, 176
Henry	1933, 210
Henry	1940, 102, 103, 105
Henry	1964, 22-4, 68
Henry	1965, 138, 139
Killanin & Duignan	1967, 359
Harbison	1975, 231

MONA INCHA I (Mona hinchá)

Ch V, Pl 34

Tighmoney, Tipperary

S170883.

Type of Monument: Cross-base

Present Location: The base has been re-erected on a concrete plinth to the west of the Romanesque church.

Evidence of Discovery: First specifically mentioned 1933.

Measurements:

H: 43 cm (17")

W: 84.5 > 68 cm (33¼" > 26¾")

D: 68 > 52 cm (26¾" > 21")

Stone Type: Fine yellowish grey sandstone.

Present Condition: Mona Incha II has now been mounted on top of Mona Incha I. The carvings on Mona Incha I are severely weathered and badly affected by lichen.

Description: The base is the shape of a truncated pyramid but it does not have a uniform number of steps on each face. On Faces A, B and D it has 1; on Face C it has 2.

Face A:

Only traces of carving survive.

Face B:

There are traces of a perimeter roll moulding on the right hand edge. No surviving ornament.

Face C:

No surviving ornament on either step. There are traces of a perimeter moulding on the left hand edge.

Face D:

The base has been divided horizontally into 2 panels without mouldings.

- 1) Two horsemen shown in profile facing left. There are traces of a small quadruped set vertically, head downwards, between the 2 horsemen. The second rider holds a spear in his left hand.
- 2) A horizontal row of double step pattern units with cut out cross

shapes in the centre of each.

Bibliography

- | | |
|----------|------------------------------|
| Henry | 1933, 117, 161; Pls 33, 106. |
| Henry | 1940, 102, 106 |
| Sexton | 1946, 171 |
| Henry | 1964, 68 |
| Henry | 1965, 138, 139; P1 80 |
| Harbison | 1975, 233 |

MONA INCHA II (Monahincha)

CH I, Pl 35.

Tighmoney, Tipperary

S170883

Type of Monument: CrossPresent Location: The cross has been re-erected to the West of the church.Evidence of Discovery: First mentioned 1804.Measurements:

H:	97 cm (38")
W of crosshead:	63 cm (24 $\frac{3}{4}$ ") approx.
<u>Shaft:</u>	W: 30 > 28 cm (11 $\frac{3}{4}$ " > 11")
	D: 20 > 19 cm (8" > 7 $\frac{1}{2}$ ")

Stone Type: Rough yellowish/grey sandstone with large grit intrusions.Present Condition: The cross has been re-erected in Mona Incha I with the addition of a modern concrete shaft. The upper part of the crosshead and the lower end of the shaft are missing. The carving is severely weathered.Description: The crosshead is Type VIb. The lower edges of the horizontal cross arms are crenellated. Before its re-erection in its present position a 'melon' shaped capstone was situated on the top of the crosshead. This is now cemented to the window sill inside the church.Face A:

1) The crosshead and the surviving part of the shaft show the Crucifixion. Only Christ is shown face on carved in high relief. His body is erect, His head missing and He has thin upward sloping arms with no apparent hands. He is clad in a long belted garment.

There are traces of perimeter mouldings on the shaft.

Face B:Crosshead:

- 1) At the end of the horizontal cross arm are traces of a slot 16cm x 18 cm.
- 2) On the lower wheel arc, anthropomorphic interlace: 2 confronted interlaced figures. The left hand figure has long curled hair, a deeply cut almond-shaped eye, a large nose and a beard (?). His right arm, is

interlaced with his opponent's left arm. He wears a knee-length tunic which is longer at the back. Only traces of the right hand figure survive. There is possibly further interlace at the bottom of the panel.

Shaft:

The panels are separated by horizontal roll mouldings.

3) Zoomorphic interlace: 2 confronted interlaced birds (?) with long beaks.

4) The lower part of the panel is missing. The surviving part shows 2 human heads, the left in profile facing right with a long nose and chin; the right face on with prominent ears, small almond shaped eyes and an incised mouth.

Face C:

1) Crosshead: Traces of interlace and perimeter mouldings on the lower edges of the horizontal cross arms.

2) On the bottom right wheel are traces of raised Z shapes.

3) Shafts: Traces of interlace.

Face D:

Crosshead:

1) On the lower wheel arc are traces of interlace.

The Shaft has perimeter roll mouldings.

2) Zoomorphic interlace: 2 sea-horse like creatures shown in profile, placed top to toe. They have long thin snouts and small almond shaped eyes. Between them are traces of interlace.

3) Zoomorphic interlace: Only the upper part survives. In the top left corner is a dog-like creature with a triangular ear, long thin snout and open mouth.

Bibliography

Ledwich	1804, 116; P1 IX
Keane	1867, 452
Carrigan	1905, II, 49
Crawford, H.S.	1907a, 207

Champneys	1910, 98
McNeill & Leask	1920, 35
Crawford, H.S.	1922, 81
Henry	1933, 137; P1 106
Sexton	1946, 171
Gleeson, D.F.	1947, 163
Henry	1964, 33, 68
Killanin & Duignan	1967, 416
Henry	1970, 117, 125, 127, 128, 130
Farnes	1975
Harbison	1975, 233

ROSCREA I (Timoney)

Ch. VII, Pl 36

Roscrea, Tipperary

S138892

Type of Monument: ShaftPresent Location: It is situated against a wall opposite the North West Doorway of St Cronan's Catholic Church, Roscrea.Evidence for Discovery: First mentioned in 1907 when it was purchased at an auction in Rockforest by Mr. Parker Hutchinson. It was adapted as a fountain and stood in the shrubbery on the Timoney Park estate until 1938 when it was purchased by the Very Rev. Tuohy and brought to Roscrea (Roe 1967, 127-9).Measurements:

H: 105 cm (42")
 [89.5 cm (35½") above MGS]
 W: 37 cm (14½")
 D: 34 > 31 cm (13½" > 12").

Stone Type: Mid yellowish grey sandstone with large pebble intrusions.Present Condition: Any carving on Face C has been lost completely as the face had been hollowed out prior to 1907 for use as a pig trough. There is a hole in the top made when it was adapted as a fountain. The carving is severely weathered.Description: The sides and top have perimeter roll mouldings. Underground the shaft tapers to a roughly triangular tenon with a rounded point.Face A:

The motives are not separated by mouldings.

- 1) A griffin shown in profile facing right with a pointed ear, hooked beak and floriate tail terminating in 3 leaf shaped tufts.
- 2) Spiral roundel (?) framed by a moulding.
- 3) Traces of ornament.

Face B

The face is divided into 3 panels by horizontal roll mouldings.

- 1) A quadruped shown in profile facing right. It bends its beaked head

with almond shaped eye towards the ground goring an object placed between its beak and front left leg.

2) Roundel of Bosses: 4 central bosses surrounded by 8 outer ones. There are traces of a 'C' scroll in the top right hand corner.

3) Traces of ornament.

Face C:

The face has been hollowed out to form a trough (H: 93 cm approx; W: 25 cm approx; D: 20 cm).

Face D:

The motives are not separated by mouldings.

1) A leonine quadruped shown in profile facing right. His head and prominent snout are raised.

2) Traces of a spiral motif with a central bird's head terminal.

Bibliography

Gleeson, J.	1915, 343-4
Gleeson, D.F.	1947, 152
Henry	1964, 24, 69
Henry	1965, 143, 144
Killanin and Duignan	1967, 416
Roe	1967
Harbison	1975, 235

ROSCREA II

Ch I, Pl 37.

Roscrea, Tipperary

S135888

Type of Monument: CrossPresent Location: It has been re-erected in St. Cronan's (Church of Ireland) Churchyard, Roscrea.Evidence of Discovery: First mentioned in 1786 as the Shrine of St Cronan. In 1841 (O'Donovan 1928a, 373-5) it consisted of 3 fragments: the crosshead was placed on the base while the lower portion of the shaft stood nearby. The fragments were then outside the churchyard but with a subsequent change in the alignment of the churchyard wall with the building of the new church they were brought within the churchyard bounds (Gleeson, J. 1915, 371).Measurements:

- I) Crosshead: H: 140 cm (55")
 W of crosshead: 157 cm (61 $\frac{3}{4}$ ") approx. (reconstructed)
Shaft: W: 41 cm (16")
 D: 26 cm (10")
- II) Lower Part of Shaft:
 H: 176.5 cm (69 $\frac{1}{4}$ ")
 W: 60 cm (23 $\frac{3}{4}$ ")
 D: 40 cm (15 $\frac{3}{4}$ ")
- III) Base: H above MGS: 12 cm (4 $\frac{3}{4}$ ") approx.
 W: 105 cm (41 $\frac{1}{2}$ ")
 D: 87 cm (34")

Stone Type: Rough yellowish grey sandstone with several large intrusions.Present Condition: The fragments have been re-erected. The upper part of the shaft and part of the crosshead have been restored with concrete. The upper wheel arcs remain missing. The carving is severely weathered.Description: Fragments I, II and III will be described together, the particular fragments concerned being indicated in the margin.The crosshead is Type VIa. The surviving horizontal cross arm is crenellated and there is a roll on the surviving wheel arc. The visible part of the base is undecorated.

Face A:

- I) 1) Crosshead: There are traces of an incised perimeter moulding. The centre is decorated with the Crucifixion. Only Christ is shown face on, His body erect, carved in high relief. The lower part of the figure is missing. He is clothed in a garment with a belt and there are traces of a couple of vertical drapery folds on the chest. The right hand is not indicated. The eyes are drilled.
- II) Shaft: The surviving part is divided horizontally into panels by roll mouldings.
- 2) and 3) Traces of zoomorphic interlace.
- III) 4) and 5) No surviving ornament.

Face B:

- I) Crosshead: restored with modern concrete.
- 1) Shaft: The panel is framed by a roll moulding and decorated with 2 human heads.
- II) 2) No surviving ornament.
- 3) An elongated human figure shown face on carved in high relief. At the centre of the top of the head is a kind of slot. It has an incised, almond shaped left eye. It is dressed in long robes with traces of vertical drapery folds. The left arm is placed by its side; the right hand holds a staff. The figure's feet, facing outwards, rest upon a plinth.

Face C:

- I) 1) Crosshead: This is decorated with a single figure shown face on carved in high relief. The lower part of the figure is missing. It is clad in robes with an upper garment indicated by 'U' shaped drapery folds. The figure holds a slender staff.
- There is a round cavity on the right hand horizontal cross arm.
- II) Shaft: The lower part is divided into 4 panels separated by horizontal roll mouldings.
- 2) No surviving ornament.
- 3) Traces of zoomorphic interlace.
- 4) Zoomorphic interlace: A serpent twirled into a figure of 8 with its head in the top left hand corner. The background is filled with interlace

strands.

5) A figural scene. There is a figure on either side dressed in long robes. The left hand is shown in profile facing right (?). Between them is a tall trunk-like object bifurcating into 2 branches part way up.

Face D:

I) Crosshead: The upper crossarm is undecorated.

1) The panel at the end of the horizontal crossarm is undecorated apart from a shallow rectangular slot 12 x 12 cm approx.

2) The lower wheel arc has narrow perimeter roll mouldings and horizontal roll mouldings along the top and bottom. It is decorated with zoomorphic interlace: 2 pairs of adored quadrupeds, one at the top and one at the bottom, their bodies forming diagonal interlace strands across the centre of the panel. The beasts have dragonesque heads, gaping jaws and sharp teeth.

Shaft:

3) A fragmentary panel with traces of carving.

II) 4) A panel with traces of interlace.

5) The rest of the shaft is decorated with an elongated figure shown face on and carved in high relief. It is dressed in a long robe, with a belt at the waist with long ties. The thin arms rest by the figure's sides. The figure is headless but there are traces of a mortice at the neck.

Bibliography

Archdall	1786, 673
Cooke	1875, 132-9
Petrie	1878, II, 39
Crawford, H.S.	1907a, 207
Champneys	1910, 98; Pl XLIV
Gleeson, J.	1915, 370-1
O'Donovan	1928a, 373-5
Porter	1931, 56; Fig. 272
Henry	1933, 71, 117, 137, 161; Fig. 33; Pl. 107
Secton	1946, 262-3
Gleeson, D.F.	1947, 151-2

De Paor, M & L	1960, 177
Henry	1964, 33, 69
Killanin & Duignan	1967, 415
Henry	1970, 117, 125, 127, 128, 130, 131, 141, 192; Fig. 30a; Pls 58, 59.
Farnes	1975
Cunningham	1976, 15

SEIR KIERAN

Ch V, Pl 38

Churchland, Offaly

N138021

Type of Monument: Cross-basePresent Location: Not in situ. It is situated within the modern churchyard wall at Seir Kieran.Evidence of Discovery: First mentioned 1871. It had been moved within the churchyard immediately prior to 1905. It has been moved again since 1937.Measurements:

Base: H: 76 cm (30")
 W: 102 > 84 cm (40" > 33")
 D: 90 > 64 cm (35½" > 25")

Socket: H: 25 cm (9½")
 W: 51 cm (20")
 D: 43 cm (17")

Stone Type: Pale grey sandstone.Present Condition: Part of Faces A and B is broken away. All carving is very severely weathered and badly affected by lichen.Description: The base is shaped like a truncated pyramid with 3 steps, the upper 2 being shallow, the third considerably deeper. There is a socket in the top. The third step is divided into panels framed by roll mouldings.Face A:

- 1) Top Step: No surviving ornament.
- 2) Middle Step: Traces of 4 strand plait.
- 3) Bottom Step: 5 figures survive on the upper half of the step. They are shown in profile facing right, their left legs raised to indicate a marching step. Each holds a spear in front of him in his right hand. They are clad in knee length tunics, have shoulder length hair and are bearded (?). To the right of these figures is a prancing horse with traces of a rider shown in profile facing left.

Face B:

The majority of the carved face is missing.

- 1) Top Step: No surviving ornament.
- 2) Middle Step: Traces of 4 strand plait.
- 3) Bottom Step: No surviving ornament.

Face C:

- 1) Top Step: No surviving ornament
- 2) Middle Step: No surviving ornament
Bottom Step: This is divided vertically into 3 panels.
- 3) Left: No surviving ornament
- 4) Central: Traces of plaitwork
- 5) Right: Traces of plaitwork

Face D:

- 1) Top Step: No surviving ornament
- 2) Middle Step: No surviving ornament
- 3) Bottom Step: This is decorated with a number of figural scenes (see Fig. 23).

(i) Bottom right, The Fall. Adam and Eve are shown in profile confronting each other either side of the Tree which divides into 2 branches which fall down behind each figure. They have traces of foliage.

(ii) To the left a half circular form with three figures shown in profile facing right shown pacing towards it. They are clad in tunics, cloaks and have shoulder length hair.

(iii) To the left is a bird-like form with an open wing, its head turned towards its tail.

(iv) In the top left hand corner is a small roof shaped object. The part above this is missing. To the right is a figure shown in profile facing left.

(v) To the right are 2 figures. On the left the first is shown in profile facing right, his left hand holding a raised sword. He has long hair. On the right the second figure is shown in profile facing left bending over an object placed between them.

(vi) To the right are 2 winged (?) horses shown in profile facing each other.

Bibliography

Graves	1871, 201
Carrigan	1905, II, 12
Crawford, H.S.	1907a, 225
Gilling	1937, 294-5
Henry	1940, 103, 106, 169, 171, 172, 174
Sexton	1946, 267
Roe	1949, Fig 7.28
Henry	1964, 69, 22-4
Henry	1965, 139-40, 147
Killanin & Duignan	1967, 120
Harbison	1975, 207

TEMPLENEIRY I (St Berrihert's Kyle)

Ch XI, Pl 39.

Ardane, Tipperary

R 946287

Type of Monument: Crosshead

Present Location: In 1946 this crosshead was built into the wall of a modern enclosure (O'hEailidhe 1967, 102). This is situated at the southern end of an oval enclosure called the 'Kyle'.

Evidence of Discovery: First mentioned 1907 when only Fragment A was known. It was then amongst a group of cross slabs forming a devotional station. Fragment B first mentioned 1967.

Measurements:

H:	80 cm (32")
W of crosshead:	102cm (40")
D:	16.5 cm(6½")

Stone Type: Fine dark pink sandstone.

Present Condition: The 2 crosshead fragments have been rejoined. The carvings are very severely weathered.

Description: The crosshead is Type Va. Faces B and D are undecorated.

Face A:

Each of the cross arms has a perimeter roll moulding.

Crosshead:

- 1) The centre is decorated with a cross of arcs, the arms of which are ornamented with short lengths of 4(?) strand plait. At the centre is a roundel (Diam. 25 cm) delineated by a roll moulding. It is decorated with a six petal marigold, each petal is slashed at the centre.
- 2) The wheel is decorated with frets: a pattern of interlocking Z elements.
- 3) The upper cross arm shows 3 figures. The central figure is face on, is dressed in a long robe and has his arms raised. The figures on either side are shown in profile facing each other and each grasps an arm of the central figure. They are clad in tunics (?). The right hand figure holds a sword (?) in his left hand; the left hand figure holds an object in his right.

4) On the left horizontal cross arm Jacob and the Angel: 2 figures are shown in profile wrestling.

5) On the right horizontal cross arm 2 figures. The right hand figure, probably in profile facing left, is clad in a tunic and raises an object aloft in his left hand. The figure on the left, smaller, is shown in profile (?) facing right. He has a cloak and tunic and may carry something in his left hand.

Face C:

Crosshead: The crossarms are outlined by a perimeter roll moulding

1) In the centre a cross of arcs as A1 with a central roundel indicated by 2 raised concentric rings. The areas between the cross and the wheel are deeply cut.

2) The arms of the cross project across the wheel which is decorated with traces of interlace.

3), 4), 5) On the cross arms there are traces of interlace.

Bibliography

Crawford, H.S.	1907a, 208
Crawford, H.S.	1909a, 61-2
Crawford, H.S.	1926a, No. 21
Henry	1933, 96, 211-2, Pl 13
Clapham	1934, 48
Sexton	1946, 276
Henry	1964, 69
Henry	1965, 147
Killanin & Duignan	1967, 284
O'hÉailidhe	1967, 106, 108; Fig. 1

TEMPLENEIRY II (St Berrihert's Kyle)

Pl 40; Ch XI

Ardane, Tipperary

R946287

Type of Monument: Cross basePresent Location: As Templeneiry I. Templeneiry I is mounted on top of Templeneiry. II.Evidence for Discovery: First mentioned 1967.Measurements:

H: 40cm (16")
 W: 125 cm (50") approx.
 D: 110 > 106 cm (43 $\frac{1}{4}$ " > 41 $\frac{3}{4}$ ")
 Socket: H: unmeasurable due to debris
 W: 40 cm (16")
 D: 23 cm (9") ..

Stone Type: . Rough reddish sandstone with many large intrusions.Present Condition: The base has been split vertically down the centre and rejoined. It is now used for the display of a large number of 'relics'.Description: The base is cut into a roughly rectangular shape. It is undecorated.Bibliography

O'hÉailidhe 1967, 108.

TEMPLENEIRY III (St. Berrihert's Kyle)

Pl 41; Ch XI

Ardane, Tipperary

R946287

Type of Monument: Crosshead

Present Location: As Templeneiry I

Evidence for Discovery: First mentioned in 1907. At that time it was described as having a shaft with a lattice work pattern. This is not mentioned in 1909.

Measurements: H: 61 cm (24")

W of crosshead: 55cm (21 $\frac{3}{4}$ ")

Shaft: W: 23 cm (9")

D: 3.5 cm (1 $\frac{1}{4}$ ") approx.

Stone Type: Pale grey sandstone.

Present Conditions: Good. The fragment is broken at the top of the shaft.

Description: The crosshead is Type VIII. Face C is embedded in the wall of the 'Kyle' and therefore any ornament is hidden. Faces B and D are undecorated.

Face A:

The centre of the crosshead is ornamented with a roundel delineated by 2 roll mouldings. Within this is a plain Greek Cross with a sunken rectangle in the centre.

Bibliography

- | | |
|--------------------|--------------------|
| Crawford, H.S. | 1907a, 208 |
| Crawford, H.S. | 1909a, 62 |
| Killanin & Duignan | 1967, 284 |
| Ó hÉailidhe | 1967, 108; Fig 2B. |

THOMASTOWN

Ch XI; P1 42

Thomastown, Kilkenny

S 381584

Type of Monument: CrossheadPresent Location: Not in situ. It is at the west end of Thomastown church.Evidence of Discovery: First mentioned in 1907.Measurements:

H:		65 cm (25½") approx.
W of crosshead:		72 cm (28¼")
<u>Shaft</u>	W:	30cm (11¾")
	D:	27 cm (10½")

Stone Type: Very rough pink granite with many large intrusions.Present Condition: The fragmentary crosshead is mounted on a modern concrete shaft. The upper part of the crosshead is missing and Face D is badly damaged.Description: The crosshead is Type VII. There are indications of perimeter mouldings on the wheel and the shaft. The cross is undecorated.Bibliography

Crawford, H.S.	1907a, 223
Pilsworth	1953, 31
Killanin & Duignan	1967, 438
Conway	1975, 158

TIHILLY (Temple Kieran)

Ch VIII, Pl 43.

Longhaun, Offaly

N302292

Type of Monument: CrossPresent Location: The cross has been re-erected on a modern limestone plinth to the East of the ruined church.Evidence of Discovery: First mentioned in 1897 when it was situated to the west of the church.Measurements:

H:	213.5 cm (84") approx.
W of crosshead (reconstructed):	62cm (24") approx.
<u>Shaft:</u>	H: 134 cm (52 $\frac{3}{4}$ ")
	W: 34 > 31 cm (13 $\frac{1}{2}$ " > 12")
	D: 18 cm (7")
<u>Base:</u>	H: 52 cm (20 $\frac{1}{2}$ ")
Diam at top:	63 cm (25")

Stone Type: Mid grey sandstone.Present Condition: The crosshead is fragmentary; the upper and one of the horizontal cross arms are missing and only a tiny section of the wheel survives. Much of the base has been restored with concrete. The carving is severely weathered.Description: The crosshead is Type IIIa. The cross and shaft are surrounded by perimeter roll mouldings banded at intervals with horizontal incised lines. The shaft is divided horizontally into 4 panels framed by a roll moulding with a vertical break. There is an undecorated butt at the bottom.

The base is conical. It is undecorated apart from 3 raised bands, one at the top and 2 at the bottom.

Face A:

1) Crosshead: The Crucifixion: Christ is shown face on, His body erect. He has short hair, is beardless and appears to be naked. His feet are bound. To either side are 2 figures, the spear bearer on the right, the cupbearer on the left. Their postures are unclear. On the right horizontal cross arm are traces of a fourth figure shown in profile facing left. There are also traces of carving above Christ's head.

Shaft:

- 2) Interlace: Encircled C in 2 registers of 2 units with a horizontal band of 2 strand twist across the bottom (UM: 2 cm; St W: 1 cm).
- 3) The Fall: Adam and Eve are shown either side of the Tree which divides into 2 branches with vegetation buds above their heads. The head of the serpent may be seen at the top of the trunk. The left hand figure is shown in profile; the right hand figure appears to be turned slightly towards the front.
- 4) Interlace: Encircled pattern, type unknown, in 2 registers of 2 units with a Simple E element set between the 2 units at the top of the pattern (UM: 2 cm; St W: 1 cm).
- 5) Winged quadruped shown in profile facing left. It has a long curved neck and a horse-like head.

Face B:

- 1) Crosshead: The only surviving ornament is a fragmentary fret pattern on the end of the horizontal crossarm.

Shaft:

- 2) Interlace: Half B with outside strands in 2 registers (UM: 2 cm; St W: 1.5 cm, median line) with a bar terminal at the top and a 3 loop filler at the bottom.
- 3) Spirals: Simple 'S' element with spiral curlicue expansions and additional curlicues in the corners of the panel.
- 4) Zoomorphic interlace: Paired confronted beasts with interlaced limbs in 1½ registers ending in a bar terminal.
- 5) Interlace: Basic A in 2 registers (UM: 2 cm; St W: 1 cm).

Face C:Crosshead:

- 1) The centre is decorated with a flat spiral roundel (Diam: 25 cm), with an inner spiral and 6 outer spirals. The outer spirals are joined by 'S' scrolls; alternate outer spirals are linked to the centre by 'C' scrolls, all with plain triangular expansions.
- 2) The left crossarm is decorated with a mesh of interlace strands.
- 3), 4), 5) There are traces of ornament on the other crossarms.

Shaft:

- 6) Frets: A carpet of interlocking [elements with a mixture of spiral and notched terminals.
- 7) Zoomorphic interlace (?)
- 8) Interlace: Basic A in 2 registers (UM: 2 cm; St W: 1 cm, double strand).
- 9) 2 confronted birds with open wings and entwined necks, a human face mask (?) set between their legs.

Face D:

Crosshead: No surviving ornament.

Shaft:

- 1) Interlace: Turned E in 2 registers with a horizontal band of 2 strand twist across the bottom (UM: 2 cm approx; St W: 1.5 cm, median line).
- 2) Zoomorphic Interlace: A procession of quadrupeds with spiralled bodies in $2\frac{1}{2}$ registers. Each basic unit stretches over 2 registers, consisting of a dog-like creature with a leaf shaped ear, upturned snout, open jaws with fleshy lips and lolling tongue. The neck and front leg, which has an enlarged paw, form diagonals across the body spiral of the creature in front. The body then curls sharply upwards forming a spiral terminating in a back leg with enlarged paw. The body spiral forming the upper register is incomplete being without neck or front leg but terminating in a beast's head.
- 3) Spirals: Combined double border in 4 registers. The 'S' scrolls have expansions with spiral curlicues; the 'C' scroll expansions are triangular and slashed.
- 4) Interlace: A single unit of Half B (UM: 2 cm approx; St W: 1.25 cm approx, double strand).

Bibliography

- | | |
|----------------|-----------------------------------|
| Williams | 1897, 129-134 |
| Crawford, H.S. | 1907a, 225 |
| Gougard | 1920, 139 |
| Crawford, H.S. | 1926a, Nos 5, 6, 46, 71, 87, 102. |

Porter	1931, 56-7, 60; Figs. 84, 104
Henry	1933, 56, 66, 98, 137; Figs. 25, 61; Pl 91
Sexton	1946, 280-1
Henry	1964, 16, 70
Killanin & Duignan	1967, 449
Harbison	1975, 207

TOUREEN PEAKAUN (Kilpeacan, Killpeacan,
Puckaun) (East Cross).

Ch XI, Pl 44

Toureen, Tipperary

RO03283

Type of Monument: Shaft

Present Location: It is mounted with other monuments on a platform of loose stones to the S.E. of the church.

Evidence for Discovery: First mentioned 1878.

Measurements:

H: 188 cm (74")
W: 51 cm (20")
D: 20 > 8 cm (8" > 3¼")

Stone Type: Pale grey sandstone

Present Condition: Weathered. The shaft is broken at the top.

Description: The shaft is slab like; the broad faces project slightly from this. Faces B and D are not decorated.

Face A:

There is a small hole in the centre at the top of the shaft.

- 1) A fragmentary incised inscription in 6 lines.
- 2) An incised Greek cross with a square centre and square expansions (RA No. 98). The expansions at the ends of the horizontal crossarms are decorated with a Simple step motif, the upper expansion with interlace, Simple E.

Face C:

At the bottom on the right hand side the shaft does not project from the slab-like backing but this is indicated with an incised line.

In the centre of the shaft is an incised Greek cross with round arm pits (RA No. 101). Beneath are traces of a vertical incised line.

Bibliography

- | | |
|-----------------|----------------------|
| Petrie | 1878, II, 33-4 (Fig) |
| ?Crawford, H.S. | 1909a, 64 |
| Duignan | 1944, 226-7 |
| Macalister | 1949, 101 |

Lionard	1960-1, 154
Moloney	1962-5, 99-101 (Fig 1)
Evans	1966, 195
Killanin & Duignan	1967, 133
Henry	1970, 125
Harbison	1975, 236
Harbison	1978, 57

TYBROUGHNEY (Tibberaghny)

Ch VII; Pl 45

Tibberaghny, Kilkenny

S440215

Type of Monument: Shaft

Present Location: Situated in the South East corner of the graveyard; set in concrete in recent times.

Evidence for Discovery: First mentioned 1897. In 1905 it is mentioned in conjunction with a socket stone but this had disappeared by 1908.

Measurements:

H: 106 cm ($41\frac{3}{4}$ ") above M.G.S.

W: 46 > 45 cm (18 " > $17\frac{3}{4}$ ")

D: 22 < 24 cm ($8\frac{1}{2}$ " < $9\frac{1}{2}$ ")

Stone Type: Mid grey sandstone.

Present Condition: Areas have been cut away at the top of the shaft on Faces C and D and near the bottom of the shaft. Face C is severely weathered.

Description: The shaft has perimeter roll mouldings accentuated by grooves along the inner edge. The lower part of each face is undecorated.

Face A:

1) A spiral roundel surrounded by a roll moulding set in a clearly defined rectangular field. The roundel has a central spiral and 6 outer spirals. The outer spirals are joined by 'S' scrolls with spiral curlicue expansions. Alternate outer spirals are joined to the centre with an 'S' scroll. Two of the outer spirals are hollowed.

Face B:

1) A stag shown in profile facing right, its left legs raised in motion. It has one antler with several upward pointing branches. There are traces of hip spirals on both front and back limbs.

2) Below, a lion, shown in profile facing right, its left legs raised in motion. Its head is turned face on, displaying rather bulbous cheeks. Its neck swells to form a mane and its body has a feline arch. Its long tail curls along its back terminating in a circular tuft.

Face C:

1) Two quadrupeds shown in profile facing right. The left hand beast's head is turned face on, the right hand beast's head is missing. Their bodies have a feline arch. The tail of the left hand beast curls along its back while the tail of the right hand beast, ending in a circular tuft, curls downwards.

2) Below, a centaur, shown in profile facing right, his head turned face on. His right hind leg is raised in motion. His body is arched and his long thin tail curls down behind him. His body has traces of incised spiral ornament on it. He has a long, thin beard and raised almond shaped eyes. His thin arms are outstretched. He holds an axe in each hand.

Face D:

1) A quadruped, its head missing, shown in profile facing left. It has an arched feline body and is tailless.

2) Below a manticora shown in profile facing right, its human head turned towards its tail which stretches the length of its back terminating in a small curl. Its face has a prominent nose and almond shaped eyes. Its body has a feline appearance and is decorated with spiral hip joints.

Bibliography

Power	1897
Carrigan	1905, II, 12; IV, 227.
Crawford, H.S.	1907a, 224
Crawford, H.S.	1908b
Crawford, H.S.	1926a, Nos. 113, 115, 116, 119; Fig. 11A
Macalister	1928, 278
Henry	1933, 42, 212-3; Pl 18
Henry	1940, 103, 105
Sexton	1946, 288-9
Roe	1962, 31-3
Henry	1964, 21-4, 70
Henry	1965, 139, 142, 155; Pl 81
Killanin & Duignan	1967, 400

ULLARD

Ch IX, P1 46

Ullard, Kilkenny

S724485

Type of Monument: CrossPresent Location: Not in situ. It now stands to the east of the church at Ullard immediately adjacent to a 'ball court'.Evidence for Discovery: First mentioned in 1839 by the Ordnance Survey (O'Donovan 1928b).Measurements:

H (reconstructed):	402 cm (168") approx.
W of crosshead :	108 cm (42½")
<u>Shaft:</u>	W: 45 > 44 cm (17¾" > 17¼")
	D: 36 > 27 cm (14" > 10½")
<u>Base:</u>	H: 94 cm (37")
	W: 90 > 68 cm (35¼" > 26¾") approx.

Stone Type: White granitePresent Condition: The central part of the shaft is missing. The cross has been reconstructed with the aid of concrete. Face C is severely weathered.Description: The crosshead is Type Ia. The base is shaped like a truncated pyramid. The cross is undecorated on Faces B and D.Face A:

The crosshead and shaft are surrounded by perimeter roll mouldings. The crosshead and shaft are divided into panels framed by roll mouldings.

1) Crosshead: On the upper crossarm, 2 figures. That on the right is shown in profile facing left. He holds an object aloft in his right hand. The figure on the left is face on. Both wear long robes with raised hem borders.

2) In the centre is the Crucifixion. Christ is shown face on, His body and head erect. He has short hair and is beardless. He is clad in a kneelength robe and his feet both point towards the right. To the right is the spear bearer, to the left the spongebearer. They sit on the armpits of the cross. To either side of Christ's head are traces of 2 angels shown face on.

- 3) On the left crossarm, David Playing the Harp. He is shown in profile facing right sitting on an 'L' shaped chair. He is clad in a kneelength tunic. A long curl of hair falls down his back.
- 4) On the right crossarm, The Sacrifice of Isaac. Abraham is on the right shown in profile facing left, a raised sword in his right hand. He wears a kneelength tunic and is bearded (?). To his left Isaac is shown in profile facing right seated on top of a small rectangular altar. Above him is the ram shown in profile facing right.
- 5), 6), 7), 8) There are traces of carving on the wheelarcs. On the bottom left (7) is a line of spirals interspersed with pairs of pellets.

Shaft:

- 9) The Fall: Adam and Eve face each other either side of the Tree which grows between them and bifurcates at the top of the panel to form two branches with circular foliage buds. Adam is on the right, Eve on the left. They wear long robes with hem borders. Adam is bearded. Each stretches an arm towards the tree.
- 10) Six figures in 2 rows of 3. Each is shown face on with ankle length robes and cloaks and round feet.

Base: The face is divided into panels in 3 registers by roll mouldings.

- 11) Top left: Interlace: 10(?) strand plait.
- 12) Top right: ?
- 13) Middle left: Spirals: 4 spirals in 2 registers of 2 joined by 'S' scrolls.
- 14) Middle right: Interlace: 6 strand plait.
- 15) Bottom left: Interlace: 5 (?) Simple E elements.
- 16) Bottom centre: RA No 692, 2 registers of 2 units.
- 17) Bottom right: As (13) with the addition of pellets in the centre and round the edge.

Face C:

Only the crosshead is decorated. It is divided into panels.

- 1) Upper cross arm: 3 figures. The central figure is upside down. Those either side are shown in profile (?) and appear to grasp the legs of the

third. They are all dressed in long robes.

2) Crosshead centre: No ornament.

3) Left horizontal crossarm: 2 figures shown face on with raised arms. They are dressed in long robes.

4) Right horizontal crossarm: Traces of 3 figures.

Bibliography

Shearman	1874-5b, 507
Allen	1887, 151, 210
Vigors	1893
Crawford, H.S.	1907a, 223
Champneys	1910, 82, 93
Stokes, M.M.	1911, 120
Galpin	1913
Crawford, H.S.	1926a, 75
O'Donovan	1928b, II, 6
Porter	1931, 27
Henry	1933, 137, 138, 140, 144, 165
Henry	1940, 169, 173, 177
Sexton	1946, 293-5
De Paor, M & L	1960, 149
Henry	1964, 25-6, 70
Henry	1965, 142
Henry	1967, 148
Killanin & Duignan	1967, 302
Conway	1975, 148
Harbison	1975, 138



Map I

IRELAND: LOCATION OF OFFALY,
KILKENNY AND TIPPERARY

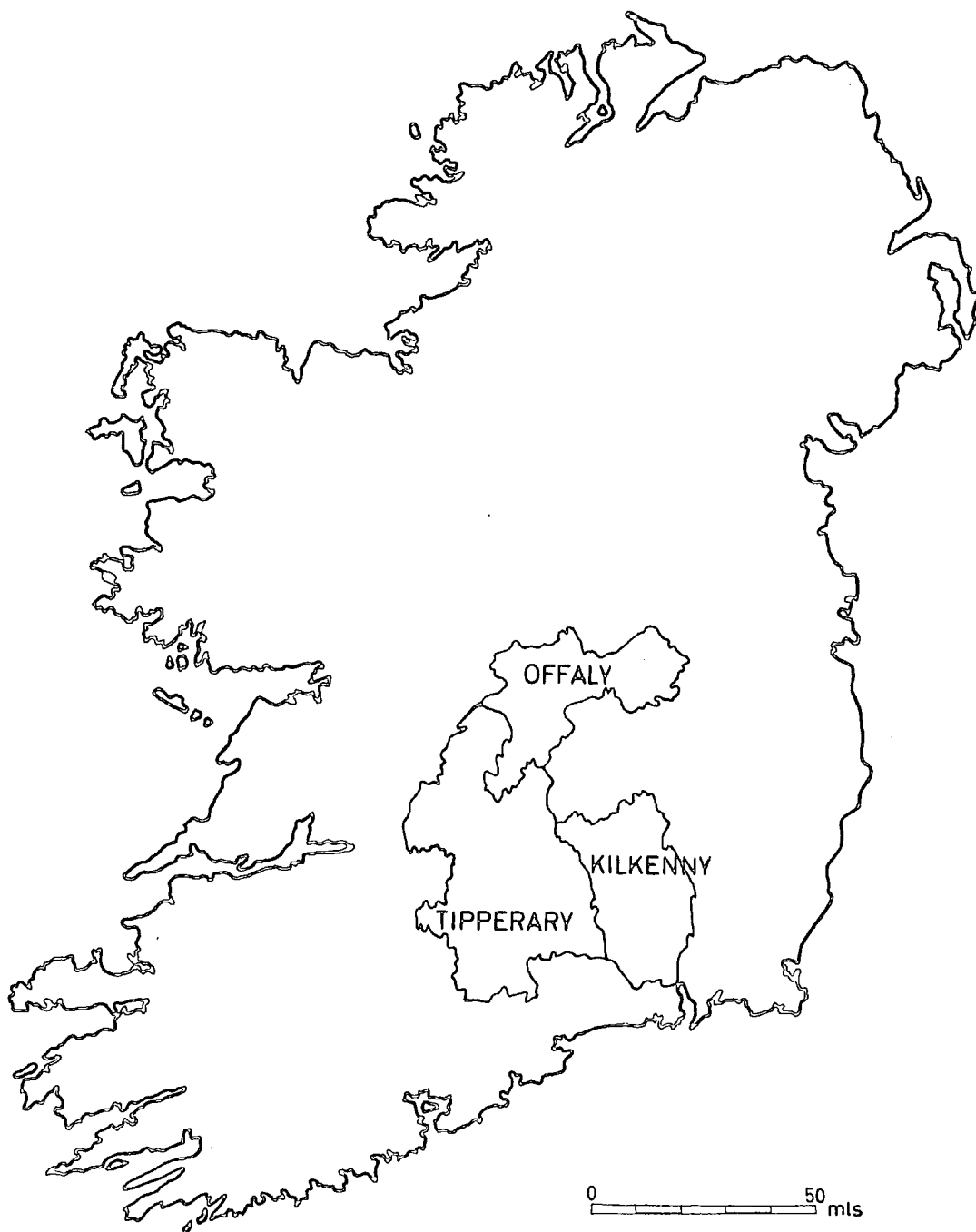

Map II EARLY GROUPS OF SCULPTURE

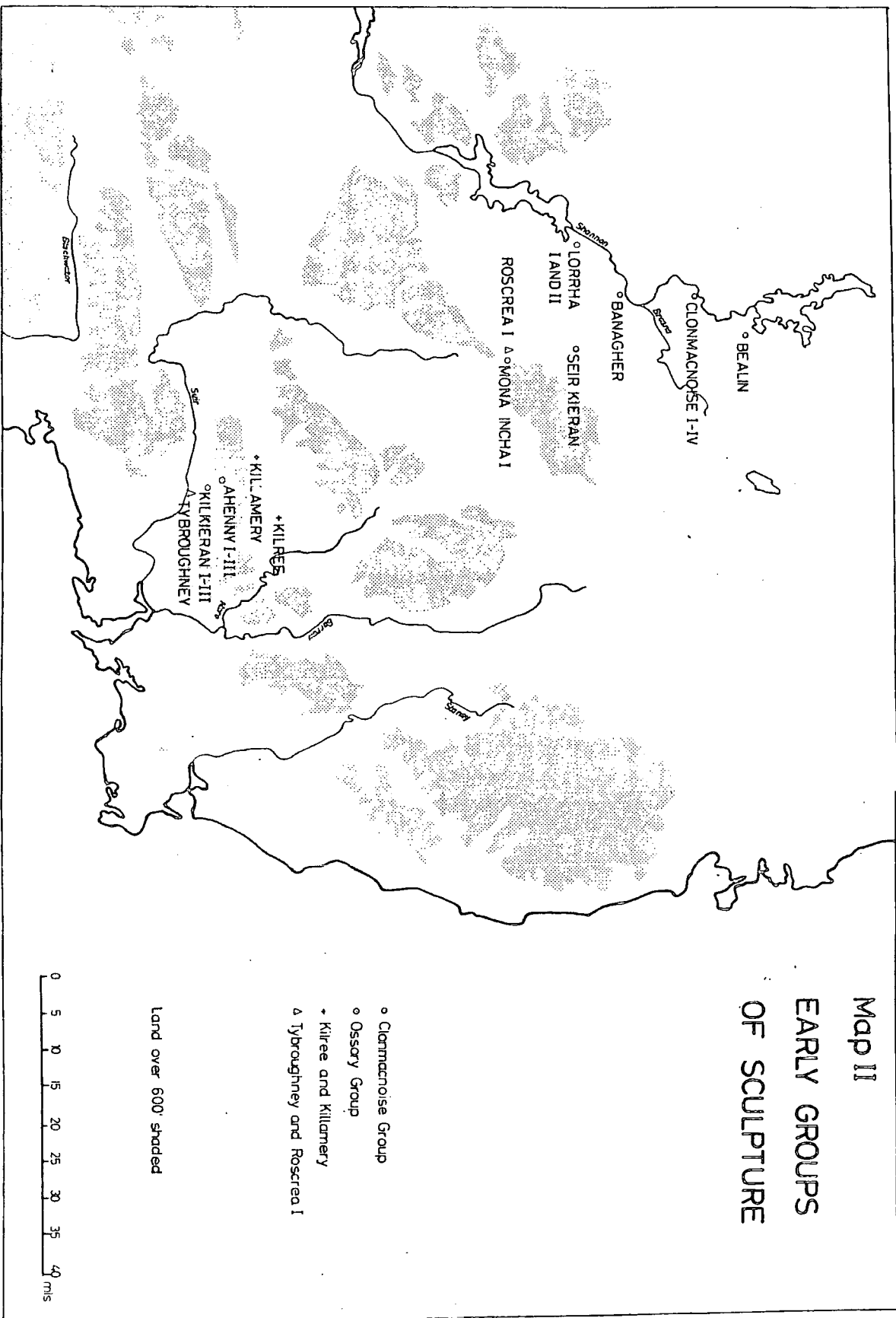

Map III

'TRANSITIONAL'
CROSSES

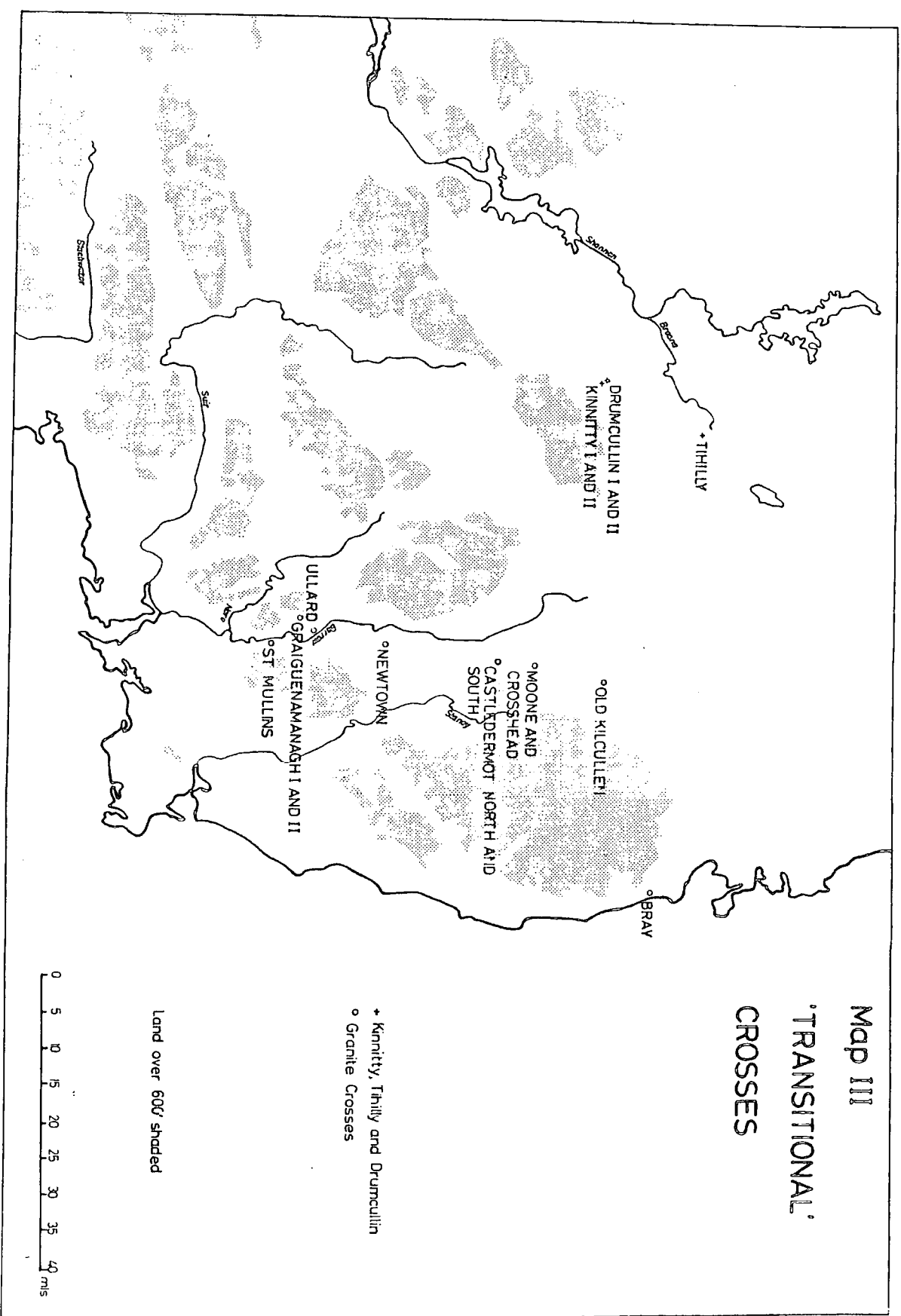

MAP IV LOCATION OF 'SCRIPTURE' CROSSES

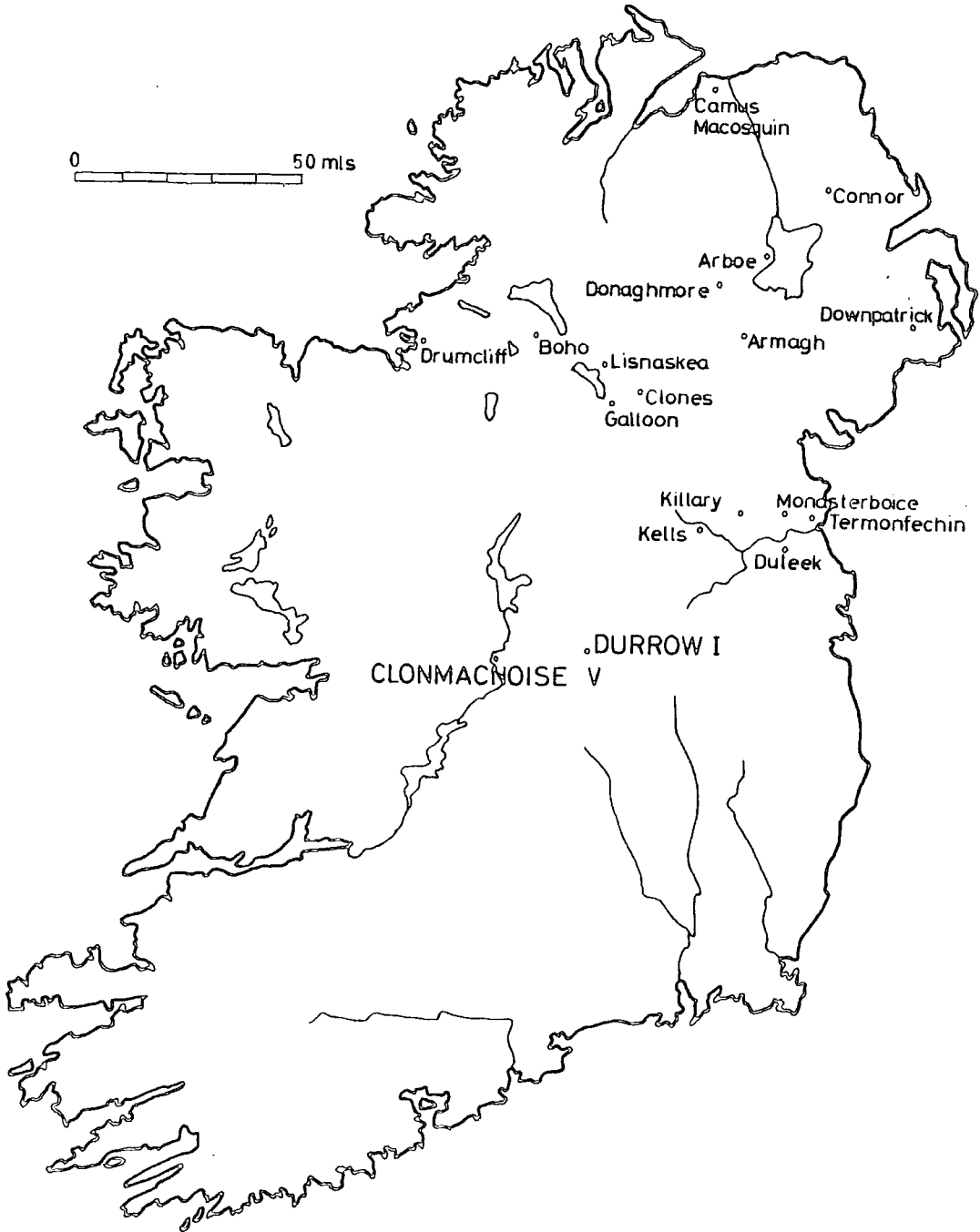

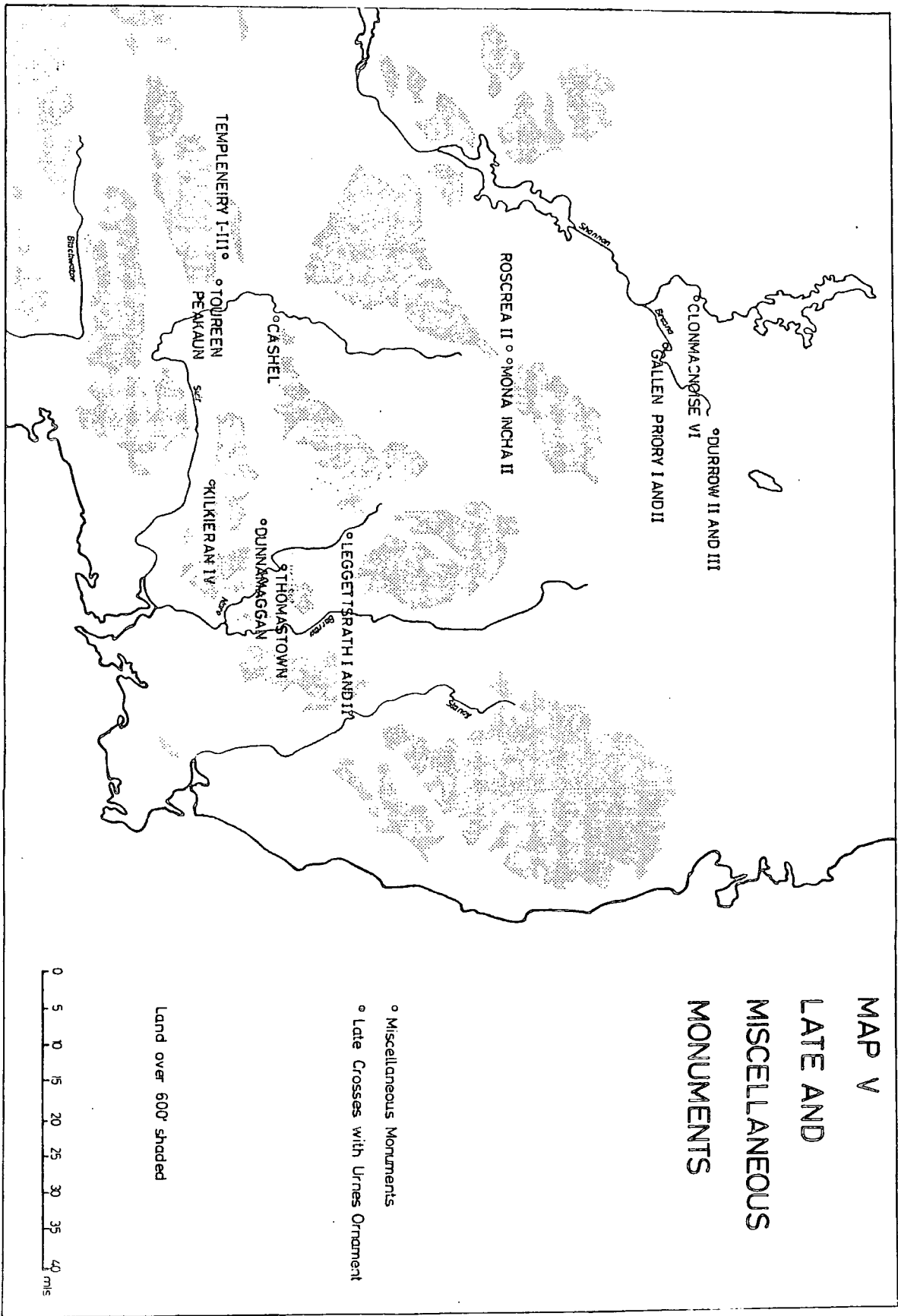

MAP V
LATE AND
MISCELLANEOUS
MONUMENTS

- Miscellaneous Monuments
- Late Crosses with Urnes Ornament

Land over 600' shaded

