

GEORGIA INSTITUTE OF TECHNOLOGY
OFFICE OF CONTRACT ADMINISTRATION
SPONSORED PROJECT INITIATION

Date: 10-10-79

Project Title: High Accuracy Radiation Efficiency Measurement Techniques

Mr Cd

Project No: A-2471

Project Director: Mr. Dennis J. Kozakoff

Sponsor: NASA; George C. Marshall Space Flight Center; Marshall Space Flight Center,
Alabama 35812

Agreement Period: From 9/27/79 Until 3/31/80 (contract period)

Type Agreement: Contract No. NAS8-33605

Amount: \$19,928

Reports Required: Informal Monthly Letters; Final Technical Report

Sponsor Contact Person (s):

Technical Matters

Mr. C.H. Guttman
PSO1
National Aeronautics and Space Administration
George C. Marshall Space Flight Center
Marshall Space Flight Center, Alabama 35812

Contractual Matters

(thru OCA)
Mr. Thomas A. Bryant
Office of Naval Research
Georgia Institute of Technology
325 Hinman Research Building
Atlanta, Georgia 30332

Defense Priority Rating: None

Assigned to: EML/RSD (~~School~~ Laboratory)

COPIES TO:

Project Director
Division Chief (EES)
School/Laboratory Director
Dean/Director-EES
Accounting Office
Procurement Office
Security Coordinator (OCA)
Reports Coordinator (OCA)

Library, Technical Reports Section
EES Information Office
EES Reports & Procedures
Project File (OCA)
Project Code (GTRI)
Other _____

GEORGIA INSTITUTE OF TECHNOLOGY
OFFICE OF CONTRACT ADMINISTRATION
SPONSORED PROJECT TERMINATION

Date: June 16, 1980

Project Title: High Accuracy Radiation Efficiency Measurement Techniques

Project No: A-2471

Project Director: Dennis J. Kozakoff

Sponsor: NASA; George C. Marshall Space Flight Center; Marshall Space Flight
AL 35812

Effective Termination Date: March 31, 1980

Clearance of Accounting Charges: March 31, 1980

Grant/Contract Closeout Actions Remaining:

- Final Invoice and Closing Documents
- Final Fiscal Report
- Final Report of Inventions
- Govt. Property Inventory & Related Certificate
- Classified Material Certificate
- Other _____

Assigned to: EML/RSD (~~School~~/Laboratory)

COPIES TO:

Project Director
Division Chief (EES)
School/Laboratory Director
Dean/Director-EES
Accounting Office
Procurement Office
Security Coordinator (OCA)
Reports Coordinator (OCA) ✓

Library, Technical Reports Section
EES Information Office
Project File (OCA)
Project Code (GTRI)
Other _____

Monthly Technical Report No. 1
and
Monthly Cost and Performance Report No. 1

Report Period
27 September through 30 September 1979

Report Prepared
1 November 1979

HIGH ACCURACY RADIATION EFFICIENCY
MEASUREMENT TECHNIQUES

D. J. Kozakoff

Contract NAS8-33605

Project A-2471

Effective Date 9/27/79
Termination Date 2/12/80

Prepared for
NASA George C. Marshall Space Flight Center
Attn: Reginald A. Inman, EC33
Marshall Space Flight Center, Alabama 35812

Prepared by
Georgia Institute of Technology
Engineering Experiment Station
Atlanta, Georgia 30332

Work Performed During This Period

The objective of this study is to investigate methods for improvement of the accuracy of antenna efficiency measurements. The specific application of the study is the Solar Power Satellite Antenna Subarray which will be electrically characterized at NASA MSFC. A program schedule for this study is shown in Figure 1.

The effort was initiated in September with comprehensive literature search to assess the state-of-the-art developments in antenna measurements.

Problems Encountered in This Reporting Period

None.

Work to be Performed Next Period

Continue literature search and evaluate pertinent technical references and papers. D. J. Kozakoff plans to attend the Antenna Measurement Techniques Symposium in Atlanta, 17-18 October, to assess latest measurements techniques.

A trip to Marshall Space Flight Center is anticipated early in October to evaluate and survey the existing antenna measurements facilities as well as potential sites for Solar Power Satellite antenna measurements.

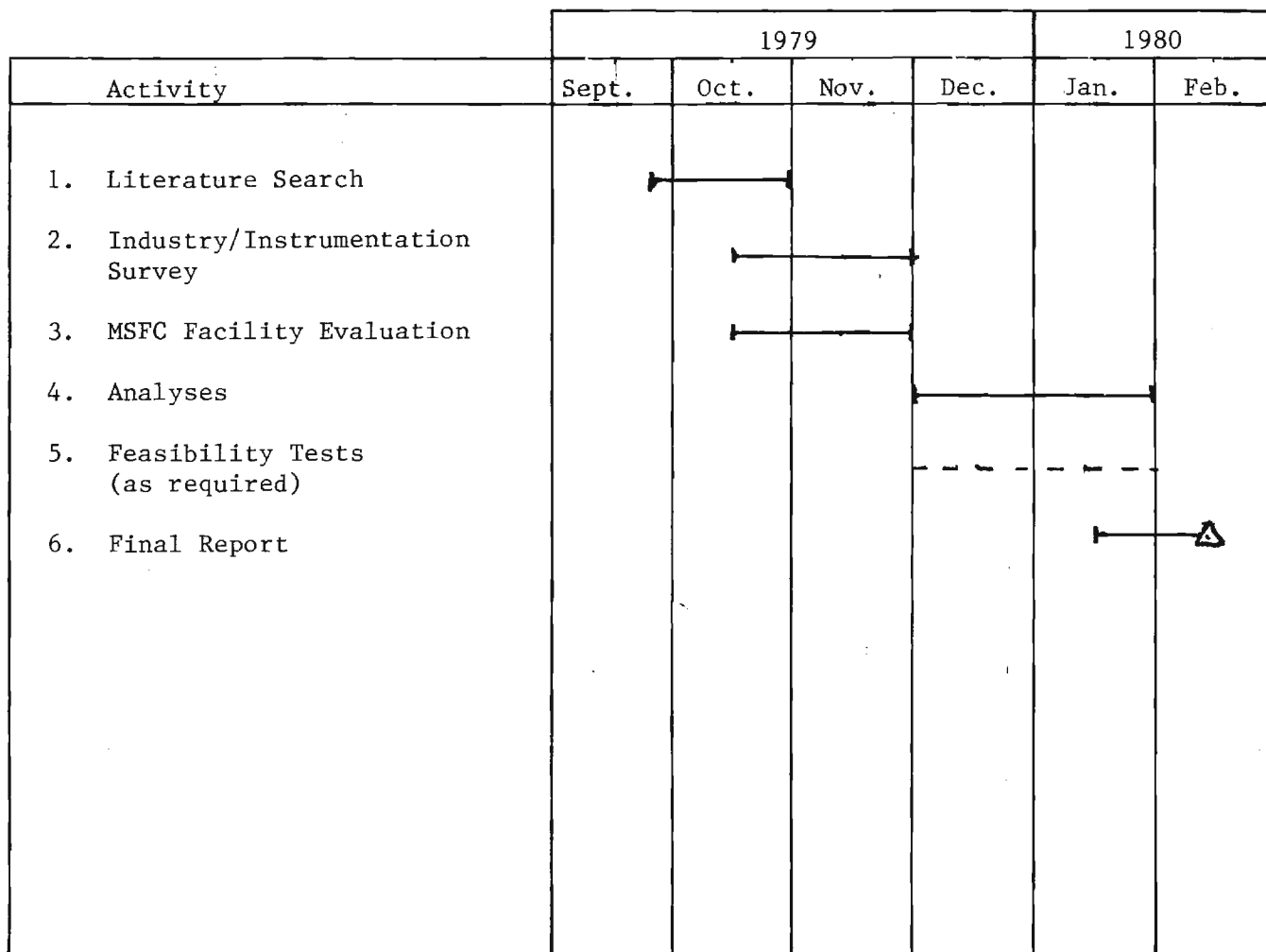

Figure 1. Program schedule for High Accuracy Radiation Efficiency Measurements Techniques.

A-2471

Cost Information

The following charges have been incurred against the contract during period 1 September through 30 September 1979.

Personal Services (PS)	\$ 866.84
Materials and Supplies	-0-
Travel	-0-
Overhead (@ 76% of PS)	658.80
Retirement (@ 10.51% of PS)	<u>91.09</u>
TOTAL	\$1,616.73

The breakdown of personal services is as follows:

	<u>Dollars</u>	<u>Approximate Man Hours</u>
Principal Research Engineers	\$ 179.58	8
Senior Research Engineers	656.39	38
Research Engineers	-0-	-0-
Assistant Research Engineers	-0-	-0-
Student Assistants	-0-	-0-
Technicians, Machinists	-0-	-0-
Clerical	<u>30.87</u>	<u>5</u>
TOTAL	\$ 866.84	51

The current financial status of the contract is as follows:

	<u>Budget As Proposed</u>	<u>Expended</u>	<u>Free Balance</u>
Personal Services (PS)	\$ 9,782.00	\$ 866.84	\$ 8,915.16
Materials and Supplies	1,000.00	-0-	1,000.00
Travel	750.00	-0-	750.00
Computer	-0-	-0-	-0-
Overhead	7,434.00	658.80	6,775.20
Retirement	<u>962.00</u>	<u>91.09</u>	<u>870.91</u>
Funding	\$19,928.00	\$1,616.73	\$18,311.27

Based on present full funding, the funding and equivalent man hours are sufficient to complete the task. Approximately 8% of the proposed task has been completed.

A-2471

Monthly Technical Report No. 2
and
Monthly Cost and Performance Report No. 2

Report Period
1 October through 31 October 1979

Report Prepared
6 November 1979

HIGH ACCURACY RADIATION EFFICIENCY
MEASUREMENT TECHNIQUES

D. J. Kozakoff

Contract NAS8-33605

Project A-2471

Effective Date: 9/27/79
Termination Date: 2/12/80

Prepared for

NASA George C. Marshall Space Flight Center
Attn: Reginald A. Inman, EC33
Marshall Space Flight Center, Alabama 35812

Prepared By

Georgia Institute of Technology
Engineering Experiment Station
Atlanta, Georgia 30332

WORK PERFORMED IN THIS REPORTING PERIOD

The review of the technical literature for state-of-the-art antenna measurement techniques which may be applicable to the Solar Power Satellite Program has been continuing. A list of technical reports and papers which has been received appears as Attachment A. These data are currently being reviewed. In addition, a significant number of reports has been ordered through the Georgia Tech technical library and is enroute.

D. J. Kozakoff has attended the Antenna Measurements Techniques Symposium in Atlanta, October 17 and 18th. A number of papers, particularly related to near field measurements, appears very pertinent. When the symposium proceedings are received, these papers will be further critiqued for their applicability.

A trip was made to MSFC 8-10 October to evaluate current antenna measurements facilities and equipments and to survey potential new measurement sites.

PROBLEM AREAS ENCOUNTERED

None to date.

WORK TO BE PERFORMED IN NEXT REPORTING PERIOD

Visit Scientific Atlanta plant in Doraville, Georgia, to discuss antenna measurements techniques and evaluate latest antenna measurements equipments. The industry/instrumentation survey will continue with other possible visits to antenna measurements facilities.

The literature search and evaluation of all pertinent technical references will continue. New measurement techniques will be identified.

The evaluation of current NASA/MSFC antenna measurements facilities will continue. A prime objective is to identify viable measurement sites which will permit maximum usage of existing facilities and equipments.

ATTACHMENT A

References In-House

1. "Accuracy Considerations in the Measurement of the Power Gain of a Large Microwave Antenna," M. Kanda, paper presented at 1974 IEEE/AP-S Symposium, Georgia Institute of Technology, Atlanta, Georgia, June 1974.
2. "Ground Plane Antenna Range Performance Measured and Calculated," J. H. Zickgraf, 1974 IEEE/AP-S Symposium, Georgia Tech, June 1974.
3. "Measurement of a Microwave Antenna Pattern from an Orbiting Space-Craft," A. C. Cook, D. L. Fayman, J. C. Holtzman, R. K. Moore, A. Sobti and W. Spencer, 1974 IEEE/AP-S Symposium, Georgia Tech, June 1974.
4. "Probe Compensated Near-Field Measurements Basic Theory, Numerical Techniques, Accuracy," W. M. Leach, Jr., E. B. Joy and D. T. Paris, 1974 IEEE/AP-S Symposium, Georgia Tech, June 1974.
5. "Application of Spherical Wave Expansions to Near-Field Problems," P. D. Potter and A. C. Ludwig, 1974 IEEE/AP-S Symposium, Georgia Tech, June 1974.
6. "Automated Near-Field Measurements to Obtain Far-Field Patterns of Aperture Antennas and Phased Arrays," H. A. Ecker, C. P. Burns, N. C. Hightower, E. C. Burdette, J. L. Evans and F. T. Riherd, 1974 IEEE/AP-S Symposium, Georgia Tech, June 1974.
7. "Cost Comparison of Near-Field Measurements and Far-Field Measurements for Far-Field Patterns," G. P. Rodrigue and C. P. Burns, 1974 IEEE/AP-S Symposium, Georgia Tech, June 1974.
8. "Comment on Correction of Errors in Aerial Far-Field Radiation-Pattern Determinations," D. M. Kerns, Electronisc Letters, Vol. 7, No. 24, 2 December 1971.
9. "Measurements and Computations of Electric Field Intensity and Power Density," Samuel Liao, IEEE Transactions on Instrumentation and Measurements, Vol. IM-26, No. 1, March 1977.
10. "Errors in Reconstruction of Radiation Patterns of Antennas on the Basis of Near-Field Phase Measurements," V. I. Turchin, V. A. Farfel and A. L. Fogel, Russian Translation.
11. "Antenna Analysis by Near-Field Measurements," Kenneth R. Grimm, Microwave Journal, April 1976.

12. "Accurate Measurement of Antenna Gain and Polarization at Reduced Distances by an Extrapolation Technique," A. C. Newell, R. C. Baird and P. F. Wacker, IEEE Transactions on Antennas and Propagation, July 1973.
13. "Evolution of Measurement Techniques in the Field of Antennas for Radars and Earth Stations," D. S. Drabowitch and M. H. Carpentier, Journal of Applied Science and Engineering, A, pp. 65-75, A2(1977).
14. "Hemispherical Power Gain Pattern Measurements at 7.5 GHz," L. L. Haidle and R. G. Fitzgerald, IEEE Transactions on Antennas and Propagation, May 1977.
15. "Accuracy Considerations in the Measurement of the Power Gain of a Large Microwave Antenna," M. Kanda, Published in Succinct Papers, IEEE Transactions on Antennas and Propagation, May 1975.
16. "The Role of the Model Positioner in an Integrated Polar Diagram Measuring System," H. E. Green, Electrical Engineering Transactions, 1977.
17. "An Integral Equation Formulation for Probe Corrected Far-Field Reconstruction from Measurements on a Cylinder," G. V. Borglotti, IEEE/AP-S International Symposium, 1977.
18. "Far-Field Large Angle Antenna Pattern Measure," R. L. Moore, B. G. Bemis, E. J. Habib, IEEE/AP-S International Symposium, 1977.
19. "On the Application of GTD for Complete Parabola Radiation Patterns," E. A. Villaseca, E. W. Smith and R. L. Moye, IEEE/AP-S International Symposium, 1977.
20. "Summary-Trends in Antenna Measurements," H. A. Ecker and R. A. Heaton, IEEE/AP-S International Symposium, 1977.
21. "Rapid Measurement and Determination of Antenna Patterns Using "Collapsed" Near-Field Data," L. J. Kaplan, T. Dowling, J. D. Hanfling and K. Grimm, IEEE AP-S International Symposium, 1977.
22. "A Characterization Technique for Near-Field Probes," D. G. Bodnar, IEEE/AP-S International Symposium, 1977.
23. "Spherical Near-Field Technique," F. Jensen, IEEE/AP-S Symposium, 1977.
24. "Results of Spherical Near-Field Measurements on Narrow-Beam Antennas," A. C. Newell and A. Repjar, IEEE/AP-S International Symposium, 1977.
25. "A Study of Near-Field Measurements System Error Levels for the Malor Phased Arrays," C. P. Burns, IEEE/AP-S International Symposium, 1977.
26. "Maximum Near-Field Measurement Error Specification," E. B. Joy, IEEE/AP-S International Symposium, 1977.

27. "Development of Electric and Magnetic Near-Field Probes," Frank M. Greene, NBS Technical Note 658, June 1975.
28. "Upper-Bound Errors in Far-Field Antenna Parameters Determined from Planar Near-Field Measurements: Part 1—Analysis," A. D. Kaghjian, NBS Technical Note 667, October 1975.
29. "Study of Development of Near-Field Test Methods for Antennas," H. Bach, et al., report prepared for European Space Agency by Electromagnetics Institute, Technical University of Denmark, Report R194, January 1978.

Cost Information

The following charges have been incurred against the contract during period 1 October through 31 October 1979

	<u>Expended</u>	<u>Encumbered</u>
Personal Services (PS)	\$1,369.76	-0-
Materials and Supplies	137.56	-0-
Travel	223.12	-0-
Overhead (@ 76% of PS)	1,041.02	-0-
Retirement (@ 10.51% of PS)	<u>141.64</u>	<u>-0-</u>
TOTAL	\$2,913.10	-0-

The breakdown of personal services is as follows:

	<u>Dollars</u>	<u>Approximate Man Hours</u>
Principal Research Scientists/Engineers	-0-	-0-
Senior Research Scientists/Engineers	\$1,312.00	77
Research Scientists II/Engineers II	-0-	-0-
Research Scientists I/Engineers I	-0-	-0-
Technicians/Draftsmen	-0-	-0-
Students	22.05	4
Secretarial/Clerical/Other	35.71	6
TOTAL	<u>\$1,369.76</u>	<u>87</u>

The current financial status of the contract is as follows:

	<u>Budget As Proposed</u>	<u>Expended</u>	<u>Free Balance</u>
Personal Services (PS)	\$ 9,782.00	\$2,236.60	\$ 7,545.40
Materials and Supplies	1,000.00	137.56	862.44
Travel and Shipping	750.00	223.12	526.88
Computer	-0-	-0-	-0-
Overhead	7,434.00	1,699.82	5,734.18
Retirement	962.00	232.73	729.27
Encumbered	-----	-----	-0-
FUNDING	<u>\$19,928.00</u>	<u>\$4,529.83</u>	<u>\$15,398.17</u>

Based on present full funding, the funding and equivalent man hours are sufficient to complete the task. Approximately 23 % of the proposed task has been completed.

Monthly Technical and Report No. 3
and
Monthly Cost and Performance Report No. 3

Report Period
1 November through 30 November 1979

Report Prepared
6 December 1979

HIGH ACCURACY RADIATION EFFICIENCY
MEASUREMENT TECHNIQUES

D. J. Kozakoff

Contract NAS8-33605

Project A-2471

Effective Date: 9/27/79
Termination Date: 2/12/80

Prepared for

NASA George C. Marshall Space Flight Center
Attn: Reginald A. Inman, EC33
Marshall Space Flight Center, Alabama 35812

Prepared by

Georgia Institute of Technology
Engineering Experiment Station
Atlanta, Georgia 30332

WORK PERFORMED THIS REPORTING PERIOD

Several visits were made to the Scientific Atlanta Plant in Doraville, Georgia, to discuss antenna measurements techniques and evaluate potential measurements hardware.

Quantification of encoder requirements for a conventional far-field antenna measurements facility were arrived at by an analysis approach. Assuming a conventional radiation distribution (RDP) type presentation of the antenna pattern data as illustrated in Figure 1, the least significant encoder bit must resolve better than

$$\delta = 0.0025 \text{ HPBW} \quad (1)$$

Table I summarizes the encoder requirement as a function of array size. The 19-bit encoder dictated by a 10 meter SPS subarray is off-the-shelf. The 30 meter mechanical module requires a 21-bit encoder which is not currently available.

In the case where complete RDP data must be stored in the computer, Table I indicates the array size rapidly increases to an unreasonable size as the antenna diameter increases.

Consideration was given to the weight handling requirements for an antenna positioner system. The weight of conventional WR340 waveguides depicted in Figure 2 was estimated as 3.1818 lbs/ft for copper and 0.9795 lbs/ft for aluminum. It was projected that the weight of an SPS prototype antenna subarray would be no less than that based on a resonant broad-wall slotted waveguide array constructed of aluminum. Table II documents the predicted weights of antenna subarrays as a function of size. It is predicted that the 10 meter subarray will weigh approximately 2.5 tons, while a 30 meter mechanical module will weigh 22.5 tons.

The state-of-the-art in antenna positioners applicable to SPS subarray antenna pattern measurements are summarized in Table III. The weight handling capabilities are adequate for the 10 meter subarray. However, even the largest positioner (Scientific Atlanta model 85) cannot handle the weight loads of the 30 meter subarray.

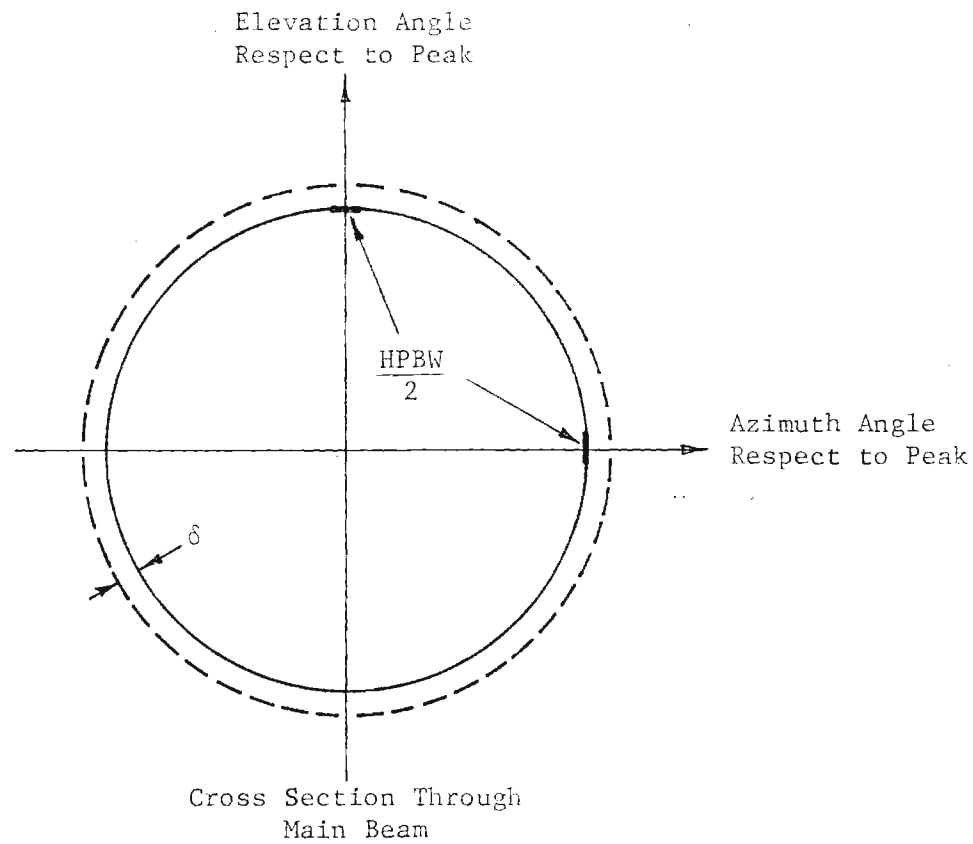

Assuming power in the main beam is proportional to beam area, the δ corresponding to 1% power change is:

$$\pi \left(\frac{\text{HPBW}}{2} + \delta \right)^2 = 1.01 \pi \left(\frac{\text{HPBW}}{2} \right)^2$$

or

$$\delta = 0.005 \left(\frac{\text{HPBW}}{2} \right)$$

Figure 1. Quantification of RDP Sample Accuracy Required

Table I.
Subarray Pattern Measurement Criteria at 2.45 GHz

Subarray Size (M)	Subarray Size (wavelengths)	Subarray HPBW* (deg)	Pattern δ for 1% Power Change (deg)	ENCODER Requirement (Bits)**	Data Array Size for ± 1.5 Degrees Square Raster***	Total Data Array Size (words)	Comments
1	8.167	6.24	0.016	16	188x188	35.344K	
3	24.502	2.081	0.0052	18	577x577	332.929K	
7	57.172	0.892	0.0022	19	1,364x1,364	1.86K	
10	81.67	0.624	0.0016	19	1,875x1,875	3.516M	Encoder Quantification to 0.00097 degrees
30	245.02	0.208	0.00052	21	5,770x5,770	33.293M	Encoder not Available
70	571.72	0.0892	0.00022	22	13,637x13,637	185.968M	Encoder not Available
100	816.7	0.0624	0.00016	23	18,750x18,750	351.562M	Encoder not Available

* Uniform illumination

** Quantification to approximately $\delta/2$

*** Sampled at $\delta/2$

WR 340 (RG 112/u)
2.2 - 3.3 GHz

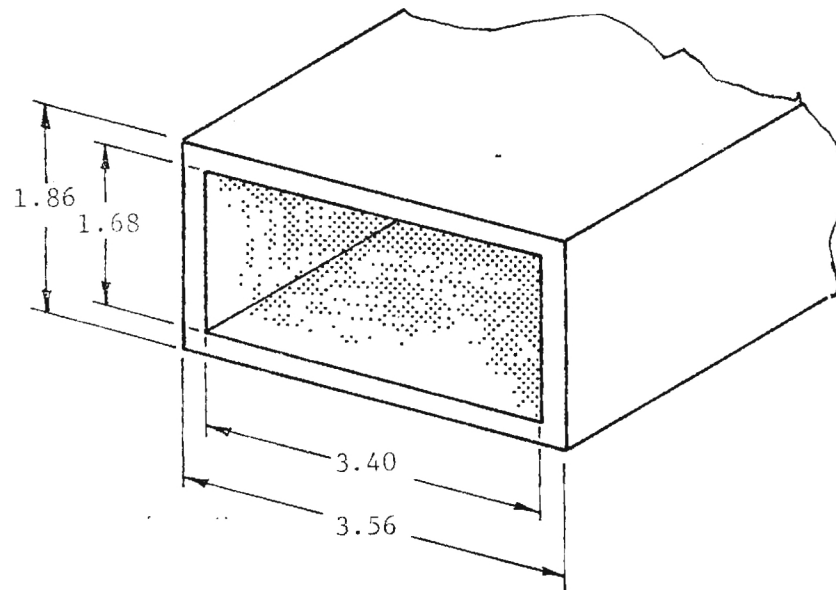

Material	Density lbs/in ³	Waveguide in ³ per ft	Waveguide lbs per ft
Copper	0.3180	10.915	3.1818
Aluminum	0.0979	10.915	0.9795

Figure 2. Waveguide Weight Estimates

Table II.
Estimates of Minimum Subarray Weight

Subarray Size (M)	Subarray Size (ft)	No. of WR340 Waveguides*	Total Length of WR340 (ft)	Total Aluminum Waveguide Wt. (tons)	Total Est. Aluminum Array Wt. (tons)	Total Copper Waveguide Wt. (tons)	Total Est. Copper Array Wt. (tons)
1	3.281	11.059	36.273	0.02	0.025	0.058	0.08
3	9.843	33.177	326.546	0.16	0.225	0.520	0.73
7	22.966	77.413	1,777.859	0.87	1.225	2.828	3.98
10	32.808	110.590	3,628.284	1.78	2.5	5.772	8.0
30	98.425	331.770	32,654.560	15.99	22.5	51.95	73.09
70	229.659	774.131	177,785.936	87.07	122.5	282.84	397.92
100	328.084	1,105.901	362,828.441	177.69	250	577.22	812.08

* Outer width = 3.56 inches = 0.2967 ft.

Table III.

Summary of State-of-the-art in Positioner Performance Applicable
to SPS Subarray Antenna Pattern Measurements

Scientific Atlanta Series**	Maximum Moment (Kft-lb)	Estimated Moment Arm* (ft)	Maximum Subarray Wt.		Cost***		
			Klbs	Tons	Elev./Az.	SMAP	Total
85	150	9.5	15.8	7.9	440K	400	840K
45	75	7.5	10	5	111K	100K	211K

* Elevation over azimuth plus SMAP configuration.

** NOTE: the series 85 has a maximum vertical load limit of 25 tons.

*** November 1979 estimates.

Quantization of RDP antenna data to better than 0.0025 of the HPBW dictated the requirement for a small angle positioner (SMAP). Figure 3 illustrates the antenna SMAP/positioner mechanism conceived for antenna pattern measurements of the 10 meter SPS subarray. Coarse raster scan RDP patterns are obtained over ± 20 degrees azimuth and elevation; larger scan angles are not readily feasible with off-the-shelf positioner hardware. Fine raster scan over ± 1.5 degrees is provided by the SMAP.

Figure 4 depicts total power in the antenna pattern of a uniformly illuminated circular aperture. The data suggests a very large percentage of the radiated power will be encompassed in ± 20 degrees about the main beam. Pattern beam power calculations for a square aperture are in progress.

PROBLEM AREAS ENCOUNTERED

None to date.

WORK TO BE PERFORMED IN NEXT REPORTING PERIOD

Further investigate data handling/computer requirements and error budgets based on conventional for field antenna pattern measurements.

The potential of near-field antenna pattern measurements will be studied.

The data obtained in the literature search is being studied for applicability.

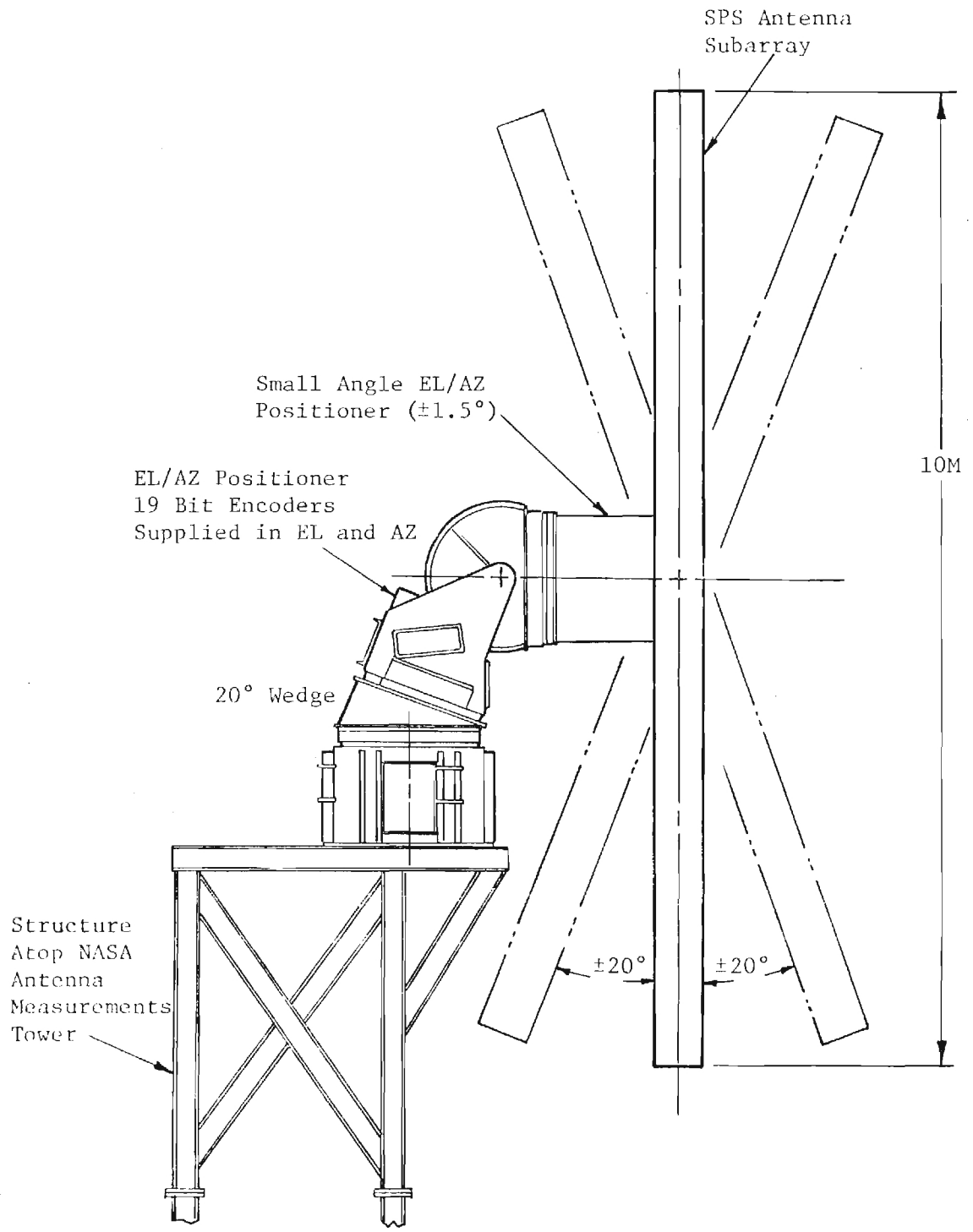

Figure 3. Antenna Positioner Mechanism for Far Field SPS Antenna Pattern Measurements.

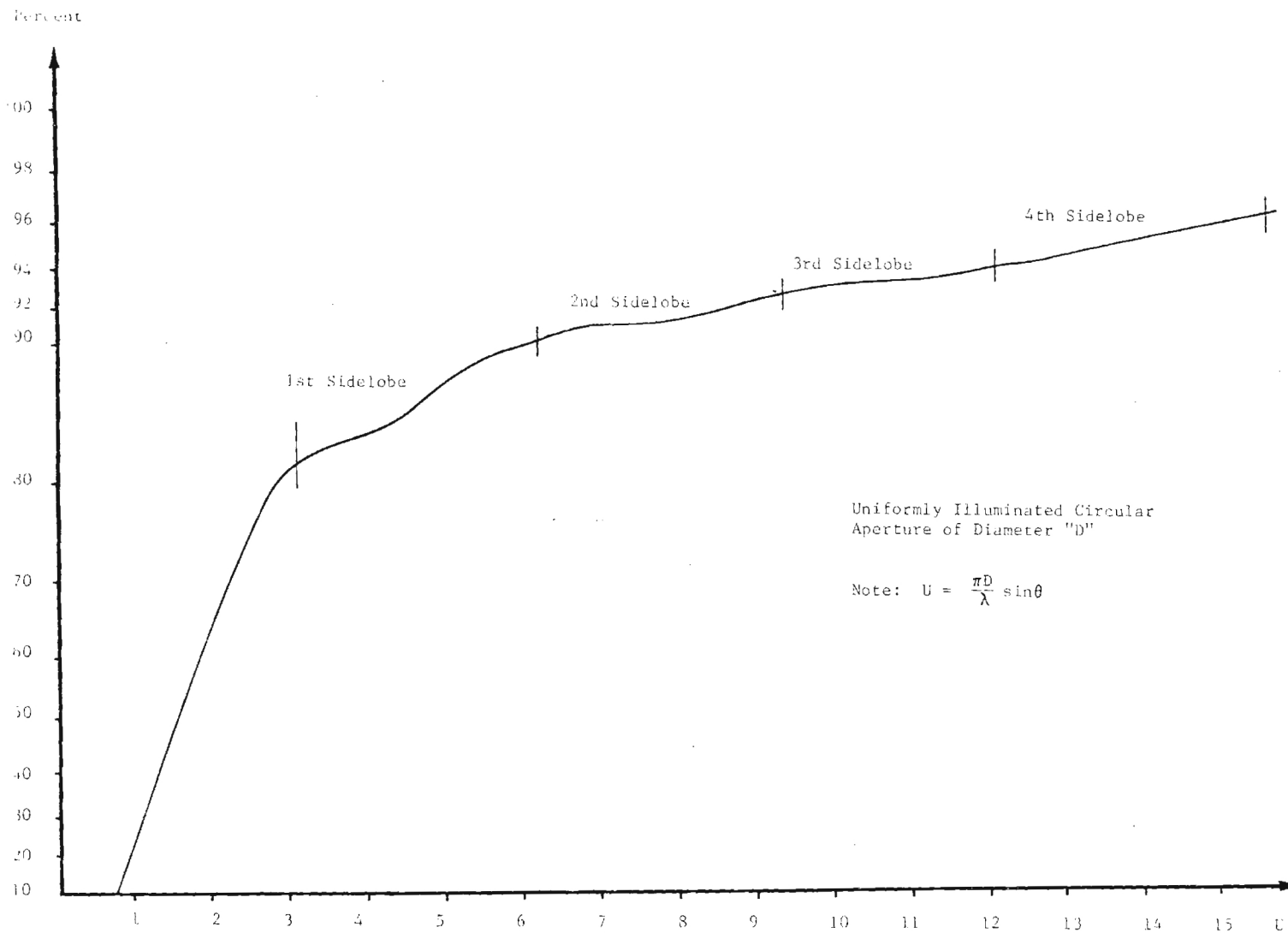

Figure 4. Percentage of Total Power in Sector of Radii "U".

Cost Information

The following charges have been incurred against the contract during period 1 November through 30 November 1979:

	<u>Expended</u>	<u>Encumbered</u>
Personal Services (PS)	\$1,583.29	
Materials and Supplies	13.93	
Travel	-0-	
Overhead (@ 76% of PS)	1,203.30	
Retirement (@ 10.51% of PS)	<u>156.94</u>	
TOTAL	\$2,957.46	

The breakdown of personal services is as follows:

	<u>Dollars</u>	<u>Approximate Man Hours</u>
Principal Research Scientists/Engineers	\$ 35.92	2
Senior Research Scientists/Engineers	1,278.80	75
Research Scientists II/Engineers II	-0-	-0-
Research Scientists I/Engineers I	-0-	-0-
Technicians/Draftsmen	-0-	-0-
Students	72.10	13
Secretarial/Clerical/Other	196.47	33
TOTAL	<u>\$1,583.29</u>	<u>123</u>

The current financial status of the contract is as follows:

	<u>Budget As Proposed</u>	<u>Expended</u>	<u>Free Balance</u>
Personal Services (PS)	\$ 9,782.00	\$3,819.89	\$ 5,962.11
Materials and Supplies	1,000.00	151.49	572.33
Travel and Shipping	750.00	223.12	526.88
Computer	-0-	-0-	-0-
Overhead	7,434.00	2,903.12	4,530.88
Retirement	962.00	389.67	572.33
Encumbered	<u>---</u>	<u>---</u>	<u>---</u>
FUNDING	\$19,928.00	\$7,487.29	\$12,440.71

Based on present full funding, the funding and equivalent man hours are sufficient to complete the task. Approximately 38% of the proposed task has been completed.

Monthly Technical and Report No. 4
and
Monthly Cost and Performance Report No. 4

Report Period

1 December through 31 December 1979

Report Prepared

6 January 1980

HIGH ACCURACY RADIATION EFFICIENCY
MEASUREMENT TECHNIQUES

D. J. Kozakoff

Contract NAS8-33605

Project A-2471

Effective Date: 9/27/79
Termination Date: 2/12/80

Prepared For

NASA George C. Marshall Space Flight Center
Attn: Reginald A. Inman, EC33
Marshall Space Flight Center, Alabama 35812

Prepared By

Georgia Institute of Technology
Engineering Experiment Station
Atlanta, Georgia 30332

WORK PERFORMED IN THIS REPORTING PERIOD

The performance potential of both far-field ground reflection and elevated ranges has been investigated. While ground reflection range geometries were identified which meet the far-field criteria with reasonable tower heights, the amplitude uniformity requirement dictated a transmit tower height of 240 feet. This is considered unreasonable.

The impact of ultra-high accuracy measurements on receiver electronics was investigated via an error sub-budget. This study identified technology areas where advances in the state-of-the-art are required. These were; precision RF attenuator, precision calibrated reference gain antenna, and a computer compensated microwave receiver. Further definition of the required receiver subsystems is in progress.

A report summarizing the present status of this study was prepared for preparation at the Solar Power Satellite Workshop at Johnson Space Center on 15-18 January 1980. A copy of the paper appears as an appendix to this progress report.

A study of near-field measurement techniques has been initiated. This measurement technique has potential for measurement of full 30-by-30 meter Mechanical Modules. However, a problem area is that the method can only be employed for intermediate transmit power levels.

PROBLEMS ENCOUNTERED IN THIS REPORTING PERIOD

Due to the time expended to prepare a summary of this study for the Solar Power Workshop, a no-cost extension of this contract was requested. This would extend the contract termination data from 2 February 1980 to 30 April 1980.

WORK TO BE PERFORMED DURING NEXT REPORTING PERIOD

An evaluation of receiver electronics required to meet the high accuracy requirement will be made. This will encompass methods of stabilization and compensation of residual error components.

Methods of realizing an ultra-high accuracy gain reference antenna will be studied. One particular method to be investigated is a radiometric technique cited to provide extremely low measurement errors.

Near-field measurement techniques will be studied further. This will include some cost and performance tradeoffs with the far-field measurement methods.

CONSIDERATIONS FOR
HIGH ACCURACY RADIATION EFFICIENCY
MEASUREMENTS FOR THE
SOLAR POWER SATELLITE (SPS) SUBARRAYS

D. J. Kozakoff, J. M. Schuchardt and C. E. Ryan

Georgia Institute of Technology
Engineering Experiment Station
Atlanta, Georgia 30332

INTRODUCTION

The relatively large apertures to be used in SPS [1], small half-power beamwidths, and the desire to accurately quantify antenna performance dictate the requirement for specialized measurements techniques. The subject matter presented herein is under investigation as part of a program at Georgia Tech to address the key issues*.

The objectives of the program include the following:

- 1) For 10-meter square subarray panels, quantify considerations for measuring power in the transmit beam and radiation efficiency to $\pm 1\%$ (± 0.04 dB) accuracy.
- 2) Evaluate measurement performance potential of far-field elevated and ground reflection ranges and near-field techniques.
- 3) Identify the state-of-the-art of critical components and/or unique facilities required.
- 4) Perform relative cost, complexity and performance tradeoffs for techniques capable of achieving accuracy objectives.

The precision required by the techniques discussed below are not obtained by current methods which are capable of $\pm 10\%$ (± 0.4 dB) performance. In virtually every area associated with these planned measurements, advances in state-of-the-art are required.

ERROR SOURCES

In general, the RF and physical environment and the electronic instrumentation all contribute to the overall measurement error. Ideally, the RF source is stable in amplitude and frequency, the transmitted wave arrives at the receiver as a true plane wave free of objectionable reflections, and the atmospheric effects are negligible. The receiver must be ideal and error free, and the gain antenna reference is accurately known. In the real world, one must deal with the errors which occur as the instrumentation departs from the ideal performance listed above.

For SPS subarray antenna pattern measurements, the critical error sources have been quantified into four categories shown in Table 1. The objective of this investigation is controlling these error sources to yield an overall gain uncertainty of ± 0.04 dB. Because of the large size of an SPS subarray (81.67-wavelengths at 2.45 GHz), antenna range effects are given

* Contract NAS8-33605

the largest allowance in the error budget. The errors allocated to transmitter/receiver sources require advances in state-of-the-art of associated microwave electronics. However, even with currently available equipment, because of single frequency operation, and the fact that receiver and transmitter are phase-locked and thermally stabilized, errors can be accurately controlled. Use of a microcomputer will permit error compensation of such factors as the nonlinearity of receiver and detector.

Controlling the antenna structure for measurement will require developing a cradle assembly that will hold the antenna rigid. Preliminary weight estimates indicate approximately 2.5 tons for a prototype subarray assembly. Ambient temperature, solar energy and wind effects can be controlled somewhat by selecting the measurement time period. However, since several thousand 10-meter apertures may need to be measured during the course of the SPS program, unique test facilities are anticipated. For instance, shielding from the adverse external parameters listed above can be achieved through use of a large dome radome.

Antenna measurements can be made with the test antenna either receiving or transmitting because of the reciprocity theorem. However, in the case where the SPS array is transmitting and the goal is to determine power in the transmit beam via beam integration, unique problems arise. Figure 1 illustrates one measurement concept being considered.

FAR-FIELD MEASUREMENT CONCEPTS

The predominant error contributors for far-field measurements are 1) field nonuniformity due to ground reflection, 2) gain loss due to quadratic phase error (near-field effects), and extraneous reflections. The National Bureau of Standards has investigated error budgets associated with far-field measurements [2]. For SPS, an adopted far-field error subbudget is shown in Table 2. The large size of an SPS subarray dictates a far-field criteria of greater than $6 D^2/\lambda$ to maintain quadratic phase error loss below 0.01 dB.

Field nonuniformity can be controlled via an elevated range concept where the receive antenna null is placed at the midpoint reflection point as depicted in Figure 2. Tradeoff calculations indicate the required tower heights for elevated range distances greater than $6 D^2/\lambda$ are not practical, however, consideration for a mountain top to mountain top range with an elevation of 600 feet and a measurement range of 7 miles appears very attractive.

Consideration was given to use of a ground reflection range facility. Here, transmit and receive tower heights are selected so that the reflection from the ground adds in phase to the direct ray path. A negative feature is that a relatively large range is required to obtain a sufficiently flat amplitude wavefront over the vicinity of the test antenna. Figure 3 relates the transmit and receive tower heights as a function of range. Under the constraint of a minimum and maximum tower height of 20 and 100 feet, respectively, and minimum range of 3 miles based on near-field criteria; the shaded area indicates regions where satisfactory operation may be obtained. The criteria for a sufficiently flat amplitude wavefront over the test zone is currently under investigation. Initial calculations indicate the performance of a 4-mile ground reflection range with receive and transmit tower heights of 30 and 70 feet, respectively, provided a wavefront within 0.1 dB over a 10-meter zone, but only with use of high efficiency absorber barricades at the midrange point.

POSITIONER CONSIDERATIONS

The large weight handling requirement (2.5 tons minimum)*, and small angular accuracy requirements, indicate that the positioner is a potential problem area based on units currently available. It has been determined that the positioner must be able to resolve a sample within 0.0016 degrees corresponding to a 19 bit encoder to resolve the beam power within a ± 0.04 dB accuracy.

A survey was made of available antenna positioners, and is summarized in Table 3. The positional accuracy of off-the-shelf positioners is on the order of 0.005 degrees. Available positioner data indicate positioning of anything larger than the 10-meter subarray will not be possible based on the weight projections.

The fractional power in the beam based on a uniformly illuminated 10-meter square aperture is plotted in Figure 4. Here, it is seen that the main beam (± 0.312 degrees) encompasses approximately 79 percent of the transmitted energy.

Based on these results, a concept was devised providing desired scan performance as illustrated in Figure 5. Here, a small angle positioner (SMAP) provides very accurate scan capability over a ± 1.5 degree sector for the purpose of beam integration. The larger gimbal arrangement provides coarse positioning over the complete ± 20 degree sector. Positioner hardware providing greater angular scan does not currently exist. From the plot of fractional beam power (Figure 4) approximately 89% of the total radiated power is accounted for within $\pm 1.5^\circ$ scan; over 99% of the power is radiated in the ± 20 degree sector.

NEAR-FIELD MEASUREMENTS

Near-field techniques utilize a calibrated probe antenna to measure the amplitude and phase of the field close to the antenna aperture. Two orthogonally-polarized probes, or a single linear-polarized probe oriented in the vertical and horizontal directions are used, together with a probe compensation technique [8, 9] to obtain the complete radiation characteristics of the antenna under test (AUT). This measurement procedure requires an automated facility capable of reading the measured data in digital form for the required computer processing. The planar near-field measurement technique is particularly attractive for SPS since the SPS subarray does not have to be moved during the measurement, i.e. only the probe antenna is moved.

Recent work at Georgia Tech has demonstrated that accurate antenna patterns can be obtained via near-field techniques [4, 5]. The National Bureau of Standards has shown that for planar near-field scanning, the near-field derived patterns are more accurate than far-field measured patterns when considering all error sources involved [6].

Martin Marietta [3] has implemented an indoor planar near-field measurements facility capable of measurement of antennas up to 50-foot diameter. The benefits of this facility include all weather operation, a thermally controlled environment (maintained within 2°F), and an RF anechoic environment. RCA has also implemented an indoor planar near-field facility for acceptance testing of the AN/SPY-1 phased array antenna for the AEGIS system [10].

*This weight estimate is based on using either conventional aluminum waveguide (without klystrons) or ultra-thin aluminum waveguide with klystrons included.

Near-field measurements can also be implemented by employing cylindrical or spherical probe scanning. However, in the spherical technique it is necessary to move the AUT while holding the probe fixed. In the case of SPS, spherical near-field scanning cannot be used because of the difficulty of gimbaling the heavy subarray in order to scan over a full sphere. However, planar and cylindrical scanning concepts are applicable. A planar scan concept is shown in Figure 6 and a cylindrical concept in Figure 7. Either system has potential to be implemented outdoors, however, the effects of thermal changes on scanning mechanism and instrumentation and the fact that an outdoor facility is subject to environmental conditions, makes an indoor near-field facility far more attractive and practical.

Tradeoff studies at Georgia Tech have suggested that the planar near-field concept has potential for array measurements of an SPS mechanical module (30 square meters). Problem areas to be resolved include computer requirements and the complexity of scanning over a much larger surface with acceptable precision. A previous study performed by Georgia Tech for NASA indicated that the cylindrical near-field technique is attractive for the measurement of electrically and physically large ground station antennas [11].

Previous studies at Georgia Tech have considered the cost tradeoffs of far-field measurements versus a near-field measurement [8, 11]. The results of these investigations for both large phased array and large reflector antennas demonstrate that costs are less for the near-field facility, and that the projected measurement accuracy is superior to that which could be obtained on a high quality far-field antenna measurement range.

However, the capital investment and operating costs of the near-field facility are functions of the required measurement accuracy. For example if the on-axis antenna gain is to be determined to within 0.01 dB, the measurement probe axial position accuracy must be within 0.1 wavelength, i.e. 0.048 inches for the SPS. Also, the scan width-to-diameter ratio must be at least 1.5. Thus, this requirement has a direct effect on the mechanical design of the near-field measurement system.

In order to obtain a complete representation of the antenna pattern from a planar or cylindrical near-field scan, the field is normally sampled at $1/2$ wavelength intervals along the linear scan dimension. If the AUT is electrically large, the required Fourier transform processing can become burdensome. However, it has been shown that the sample spacing can be increased by almost an order of magnitude if only the main-beam and first sidelobes are to be defined [4, 11].

In order to obtain accurate polarization information on the antenna pattern, the polarization characteristics of the measurement probe must be carefully characterized over the maximum possible dynamic range. Work at RCA [7] has also indicated that careful probe polarization design is necessary too if a very accurate gain determination is required. For instance, assuming an SPS antenna polarization ratio of 30 dB, a probe polarization ratio of 20 dB will result in a gain measurements error of approximately 0.25 dB. Thus, a very stringent requirement is placed on probe polarization ratio; a requirement of 30 dB, or better, is anticipated.

CONCLUSIONS

Because of the large electrical size of the SPS subarray panels and the requirement for high accuracy measurements, specialized measurement facilities are required. Most critical measurement error sources have been identified for both conventional far-field and near-field techniques. Although the adopted error budget requires advances in state-of-the-art of microwave instrumentation, the requirements appear feasible based on extrapolation from today's technology.

Additional performance and cost tradeoffs need to be completed before the choice of the preferred measurement technique is finalized.

REFERENCES

1. "Solar Power Satellite Concept Development and Evaluation Program," U.S. Department of Energy and NASA Report, October 1978.
2. "Accuracy Considerations in the Measurement of the Power Gain of a Large Microwave Antenna," M. Kanda, 1974 IEEE/AP-S Symposium, Georgia Tech, Atlanta, June 1974.
3. "Near-Field Pattern Measurement Facility," C. E. Kirchoff, 1979 Antenna Applications Symposium, U. of Illinois, September 1979.
4. "Probe Compensated Near-Field Measurements Basic Theory, Numerical Techniques, Accuracy," W. M. Leach, Jr., E. B. Joy and D. T. Paris, IEEE/AP-S Symposium, Georgia Tech, June 1974.
5. "Automated Near-Field Measurements to Obtain Far-Field Patterns of Aperture Antennas and Phased Arrays," H. A. Ecker, et al, IEEE/AP-S Symposium, Georgia Tech, June 1974.
6. "Upper Bound Errors in Far-Field Antenna Parameters Determined From Planar Near-Field Measurements: Part 1-Analysis," A. D. Kaghjian, National Bureau of Standards Technical Note 667, October 1975.
7. "Automated Near-Field Test Set for Phased Array Production," D. Staiman, 1979 Antenna Applications Symposium, U. of Illinois, September 1979.
8. "Correction of Near-Field Antenna Measurements Made with an Arbitrary But Known Measuring Antenna," D. M. Kerns, Electronics Letters, Vol. 6, May 1970.
9. "Plane Wave Scattering Matrix Theory of Antenna and Antenna-Antenna Interaction: Formulation and Application," D. M. Kerns, Journal of Research of the Nation Bureau of Standards, Vol. 80B, No. 1, January 1976.
10. "Implimenting a Near-Field Antenna Test Facility," W. A. Harmening, Microwave Journal, Vol. 22, No. 9, September 1979
11. "A Study of the Application of Near-Field Measurements for NASA Requirements," B. J. Cown, C. E. Ryan, Jr., A. L. Bridges and J. D. Adams, Final Engineering Report, Contract NAS5-2234, Georgia Institute of Technology, March 1976.

TABLE 1
MEASUREMENTS ERROR BUDGET

ERROR SOURCE	ERROR COMPONENTS	ALLOWABLE VALUE IN ERROR BUDGET	COMMENTS
ANTENNA RANGE	FIELD UNIFORMITY		
	QUADRATIC PHASE ERROR		
	EXTRANEIOUS REFLECTIONS	.037 dB	
	STANDARD GAIN ANTENNA UNCERTAINTY		AN ADEQUATE GAIN STANDARD HAS NOT YET BEEN IDENTIFIED
	ATMOSPHERIC EFFECTS		REFERENCE RECEIVER MUST BE USED TO NORMALIZE EFFECTS OF ATMOSPHERE
STRUCTURAL/ ENVIRONMENTAL	SPS ANTENNA RIGIDITY/STABILITY		
	*POSITIONER ERROR	.01 dB	
	WIND LOADING THERMAL		WIND LOADING/THERMAL CAN BE CONTROLLED BY RADOME OVER TEST ANTENNA
TRANSMITTER	AMPLITUDE STABILITY		PHASE LOCKED TECHNIQUES AND TEMPERATURE STABILIZATION MUST YIELD AMPLITUDE STABILITY OF 0.007 dB
	FREQUENCY STABILITY	.01 dB	
RECEIVER	PRECISION ATTENUATOR UNCERTAINTY		ATTENUATOR CALIBRATED TO 0.005 dB
	REFERENCE INPUT PHASE/ AMPLITUDE ERRORS		
	SIGNAL TO NOISE RATIO	.01 dB	S/N RATIO MUST EXCEED 40 dB
	FREQUENCY STABILITY		
	DYNAMIC RANGE		THROUGH ENVIRONMENTAL CONTROL DETECTOR CALIBRATION CAN EXCEED 0.005 dB
	DETECTOR LINEARITY VSWR		VSWR KEPT BELOW 1.05

TOTAL RSS = .04 dB

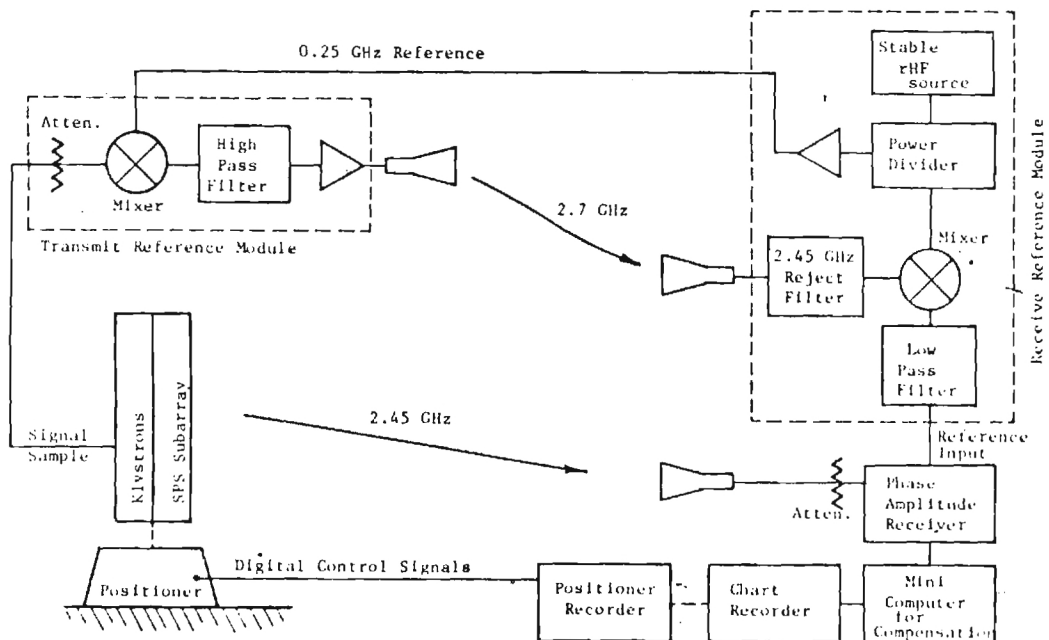

Figure 1. Equipment Configuration for Antenna Measurements.

TABLE 2
 ANTENNA RANGE MEASUREMENTS
 ERROR SUB-BUDGET

<u>ERROR COMPONENT</u>	<u>ALLOWABLE VALUE</u>	<u>COMMENTS</u>
Field Uniformity	0.015 dB	Maximum amplitude taper at edge of SPS subarray approx. 0.04 dB
Quadratic Phase Error	0.010 dB	Requires range greater than $6 D^2/\lambda$
Standard Gain Antenna Uncertainty	0.020 dB	Gain standard needs to be developed
Atmospheric Effects	0.005 dB	Atmospheric effects cancelled by reference
VSWR	0.005 dB	VSWR loss calibrated out
Extraneous Reflections	0.025 dB	Extraneous reflections -57 dB down
RSS Subtotal	0.037 dB	

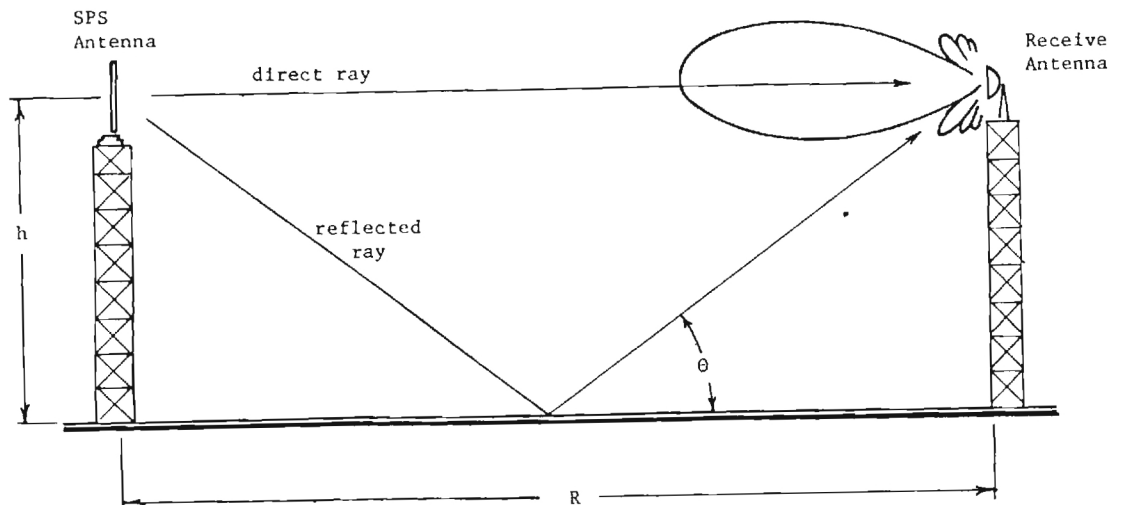
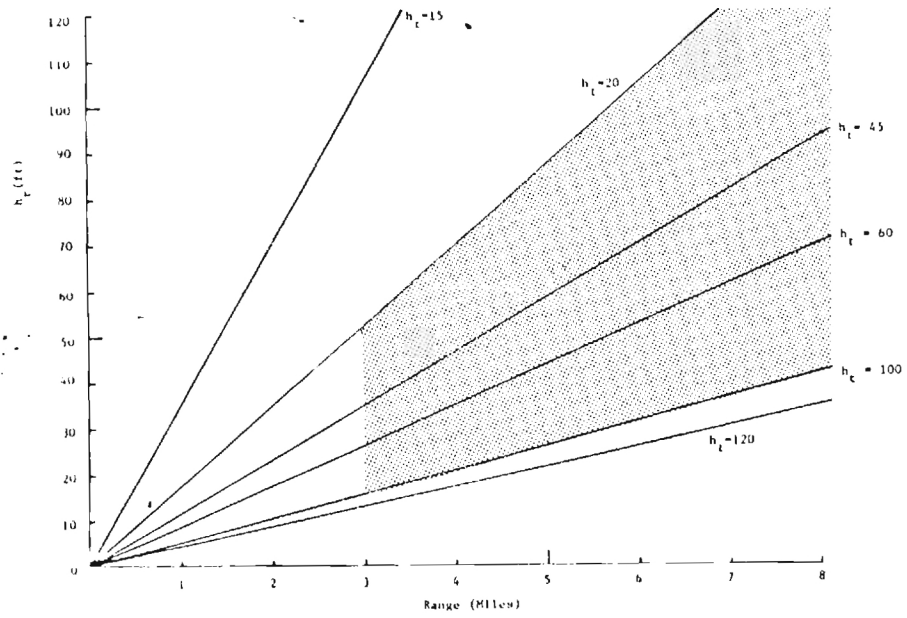

Figure 2. Elevated Antenna Range.



Note: This area is a usable operating region.

Figure 3. Relation Between Receive Antenna Height (h_r), and Transmit Antenna Height (h_t) for a Ground Reflection Antenna Range.

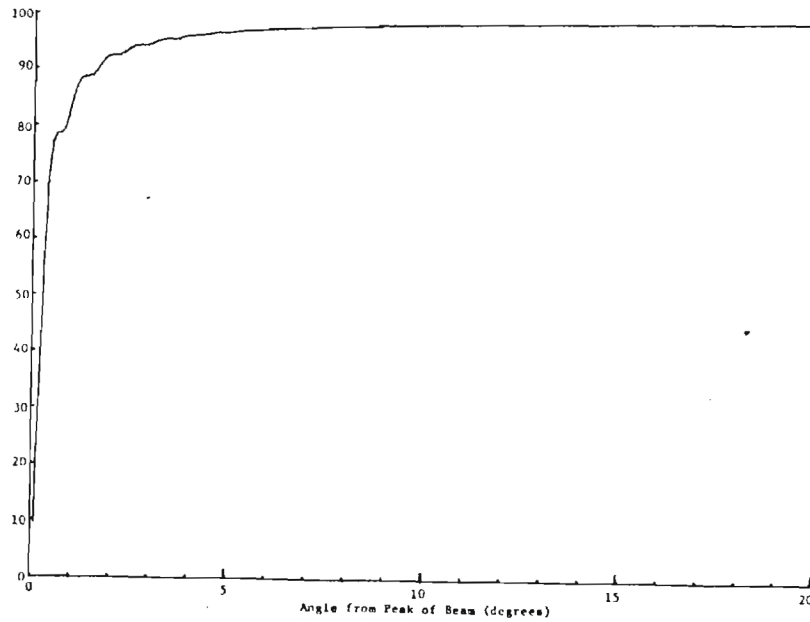

Figure 4. Fractional Beam Power for SPS Subarray Pattern.

Figure 5. Antenna Positioner Mechanism For Far-Field Pattern Measurements

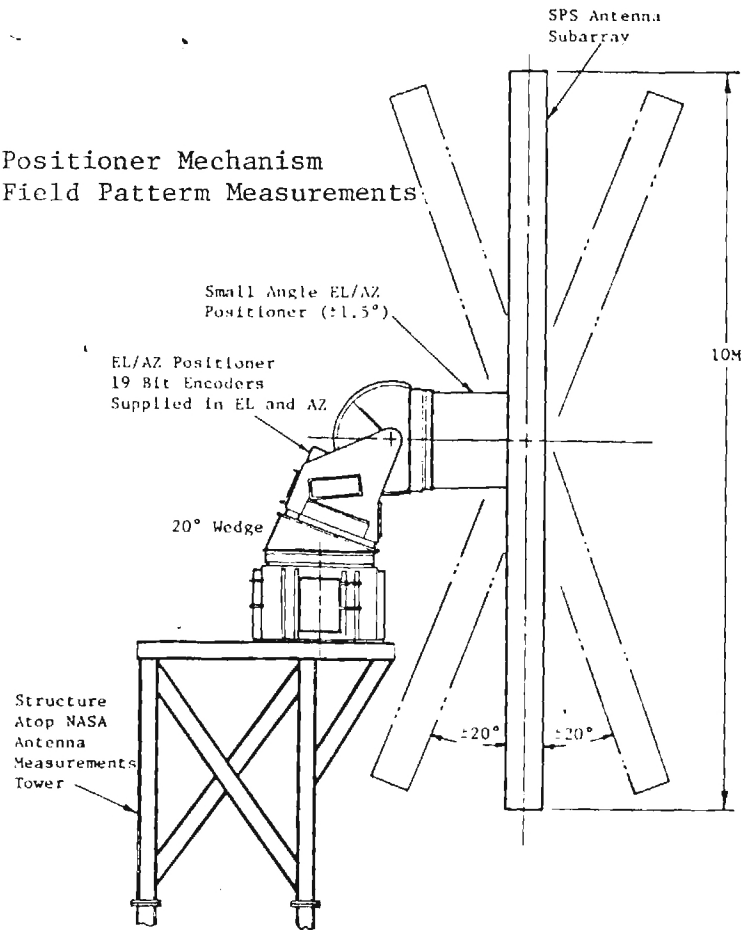

TABLE 3
SUMMARY OF POSITIONER PERFORMANCE

Scientific Atlanta Series**	Maximum Moment (Kft-lb)	Estimated Moment Arm* (ft)	Maximum Subarray Wt.		Cost***		
			Klbs	Tons	Elev./Az.	SMAP	Total
85	150	9.5	15.8	7.9	\$ 440K	\$400K	\$ 840K
45	75	7.5	10	5	\$ 111K	\$100K	\$ 211K

* Elevation over azimuth plus SMAP configuration.

** NOTE: the series 85 has a maximum vertical load limit of 25 tons.

*** November 1979 estimates.

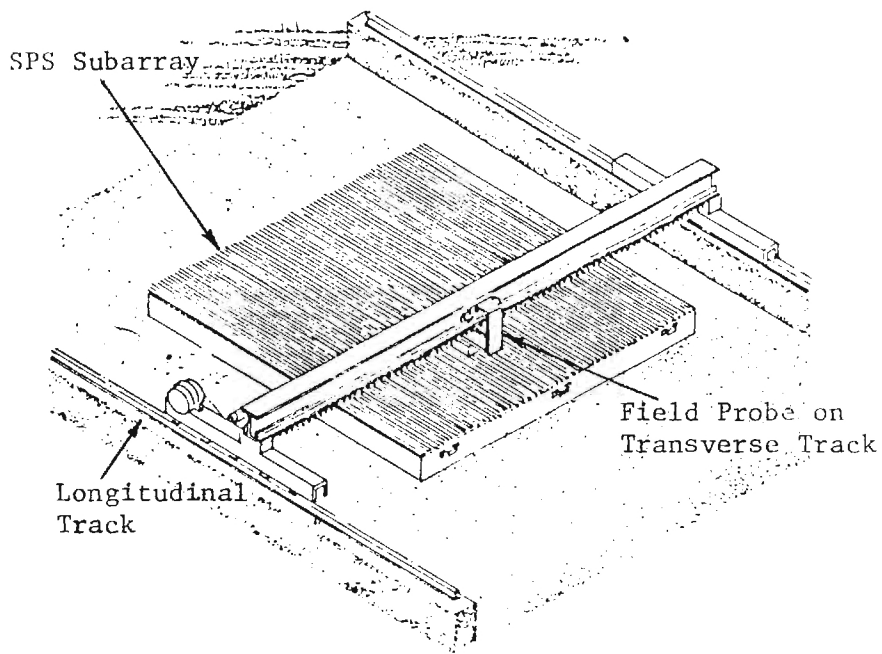

Figure 6. Planar Scanner Concept for Near-Field Measurements.

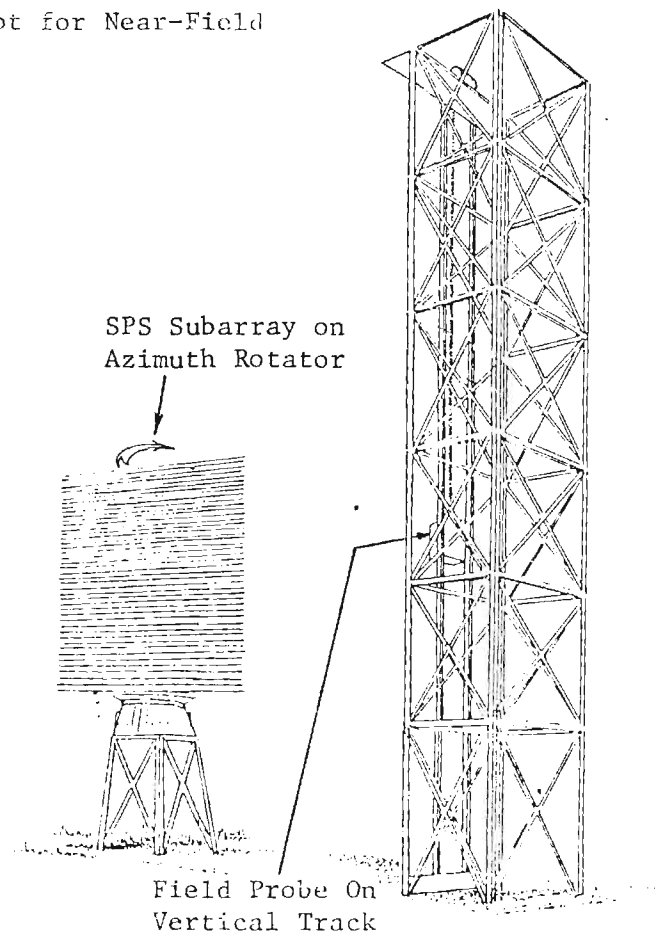

Figure 7. Cylindrical Scanner Concept for Near-Field Measurements.

Cost Information

The following charges have been incurred against the contract during period 1 December through 31 December 1979.

	<u>Expended</u>	<u>Encumbered</u>
Personal Services (PS)	\$3,218.12	\$ -0-
Materials and Supplies	8.93	-0-
Travel	37.86	10.00
Overhead (@ 76% of PS)	2,445.77	-0-
Retirement (@ 10.51% of PS)	319.59	-0-
TOTAL	<u>\$6,030.27</u>	<u>\$ 10.00</u>

The breakdown of personal services is as follows:

	<u>Dollars</u>	<u>Approximate Man Hours</u>
Principal Research Scientists/Engineers	\$ 35.91	2
Senior Research Scientists/Engineers	2,760.14	162
Research Scientists II/Engineers II	-0-	-0-
Research Scientists I/Engineers I	-0-	-0-
Technicians/Draftsmen	104.77	13
Students	177.20	31
Secretarial/Clerical/Other	140.10	24
TOTAL	<u>\$3,218.12</u>	<u>232</u>

The current financial status of the contract is as follows:

	<u>Budget As Proposed</u>	<u>Expended</u>	<u>Free Balance</u>
Personal Services (PS)	\$ 9,782.00	\$ 7,038.01	\$2,743.99
Materials and Supplies	1,000.00	160.42	839.58
Travel and Shipping	750.00	260.98	479.02
Computer	-0-	-0-	-0-
Overhead	7,434.00	5,348.89	2,085.11
Retirement	962.00	709.26	252.74
Encumbered	-0-	10.00	-0-
FUNDING	<u>\$19,928.00</u>	<u>\$13,527.56</u>	<u>\$6,400.44</u>

Based on present full funding, the funding and equivalent man hours are sufficient to complete the task. Approximately 68% of the proposed task has been completed.

Monthly Technical Report No. 5
and
Monthly Cost and Performance Report No. 5

Report Period
1 January through 31 January 1980

Report Prepared
18 February 1980

HIGH ACCURACY RADIATION EFFICIENCY
MEASUREMENT TECHNIQUES

D. J. Kozakoff

Contract NAS8-33605
Project A-2471
Effective Date: 9/27/79
Extended Expiration Date: 3/31/80

Prepared for

NASA George C. Marshall Space Flight Center
Attn: Reginald A. Inman, EC 33
Marshall Space Flight Center, Alabama 35812

Prepared by

Georgia Institute of Technology
Engineering Experiment Station
Atlanta, Georgia 30332

WORK PERFORMED IN THIS REPORTING PERIOD

A trip was made to Scientific Atlanta to discuss high accuracy microwave receivers for use for the SPS antenna measurements.

The study of measurement techniques has continued. Of particular interest are developments of methods of precision calibration of standard gain antenna references.

A report of the status of this study was presented at the Solar Power Satellite Workshop at Johnson Space Center, Houston, on 15-18 January 1980.

PROBLEMS ENCOUNTERED IN THIS REPORTING PERIOD

None.

WORK TO BE PERFORMED DURING NEXT REPORTING PERIOD

Perform power density calculations for a candidate outdoor mountain-top to mountain-top elevated range, make plots of power contour footprints on ground. Cost tradeoffs between far-field and near-field techniques will be accomplished.

A-2471

Cost Information

The following charges have been incurred against the contract during period 1 January through 31 January 1980.

	<u>Expended</u>	<u>Encumbered</u>
Personal Services (PS)	\$2,286.76	\$ -0-
Materials and Supplies	18.68	-0-
Travel	120.00	119.00
Overhead (@ 76% of PS)	1,737.94	-0-
Retirement (@ 10.51% of PS)	178.30	-0-
TOTAL	<u>\$4,341.68</u>	<u>\$119.00</u>

The breakdown of personal services is as follows:

	<u>Dollars</u>	<u>Approximate Man Hours</u>
Principal Research Scientists/Engineers	\$ -0-	-0-
Senior Research Scientists/Engineers	1,560.41	91
Research Scientists II/Engineers II	-0-	-0-
Research Scientists I/Engineers I	-0-	-0-
Students	590.30	104
Machinists	-0-	-0-
Secretarial/Clerical/Other	136.05	23
TOTAL	<u>\$2,286.76</u>	<u>218</u>

The current financial status of the contract is as follows:

	<u>Budget As Proposed</u>	<u>Expended</u>	<u>Free Balance</u>
Personal Services (PS)	\$ 9,782.00	\$ 9,324.77	\$ 457.23
Materials and Supplies	1,000.00	179.10	820.90
Travel and Shipping	750.00	380.98	240.02
Computer	-0-	-0-	-0-
Overhead	7,434.00	7,086.83	347.17
Retirement	962.00	887.56	74.44
Encumbered	-0-	129.00	-0-
FUNDING	<u>\$19,928.00</u>	<u>\$17,988.24</u>	<u>\$1,939.76</u>

Based on present full funding, the funding and equivalent man hours are sufficient to complete the task. Approximately 90 % of the proposed task has been completed.

FINAL TECHNICAL REPORT

Project A-2471

**HIGH ACCURACY RADIATION EFFICIENCY
MEASUREMENT TECHNIQUES**

By

D. J. Kozakoff and J. M. Schuchardt

Prepared by

GEORGIA INSTITUTE OF TECHNOLOGY

**Engineering Experiment Station
Atlanta, Georgia 30332**



15 April, 1980

FINAL TECHNICAL REPORT FOR PERIOD September 1979 – March 1980

Contract NAS8-33605

Prepared for

**NATIONAL AERONAUTICS AND SPACE ADMINISTRATION
George C. Marshall Space Flight Center
Marshall Space Flight Center, Alabama 35812**

PROJECT NO. A-2471

HIGH ACCURACY RADIATION EFFICIENCY
MEASUREMENT TECHNIQUES

D.J. KOZAKOFF AND J.M. SCHUCHARDT

FINAL REPORT FOR PERIOD 27 September 1979 - 31 March 1980

GEORGIA INSTITUTE OF TECHNOLOGY
ENGINEERING EXPERIMENT STATION
Atlanta, Georgia 30332

15 April 1980

Prepared for

NASA George C. Marshall Space Flight Center
MSFC, Alabama 35812

Contract NAS8-33605

1. Report No.	2. Government Accession No.	3. Recipient's Catalog No.	
4. Title and Subtitle High Accuracy Radiation Efficiency Measurements Techniques		5. Report Date 15 April 1980	6. Performing Organization Code
		8. Performing Organization Report No.	
7. Author(s) D. J. Kozakoff and J. M. Schuchardt		10. Work Unit No.	
9. Performing Organization Name and Address Engineering Experiment Station Georgia Institute of Technology Atlanta, Georgia 30332		11. Contract or Grant No. NAS8-33605	
		13. Type of Report and Period Covered Final Report 9/27/79 - 3/31/80	
12. Sponsoring Agency Name and Address NASA Marshall Space Flight Center MSFC, Alabama 35812		14. Sponsoring Agency Code	
15. Supplementary Notes Contract Technical Monitor: R.A. Inmann (EC33)			
16. Abstract This document contains the results of a high accuracy antenna efficiency measurements study applicable to SPS. The measurement potential of conventional far-field and near-field antenna measurement techniques are evaluated. Error budgets and facility cost tradeoffs are formulated. The results indicate advances in state-of-the-art of measurements electronics are required. The overall facility cost of a near-field concept was found to be roughly the same as an elevated far-field antenna range.			
17. Key Words (Selected by Author(s)) Solar Power Satellite, Antenna Measurements, Radiation Efficiency		18. Distribution Statement	
19. Security Classif. (of this report) Unclassified	20. Security Classif. (of this page) Unclassified	21. No. of Pages 77	22. Price*

* For sale by the National Technical Information Service, Springfield, Virginia 22151.

FOREWORD

This technical report was prepared by the Electromagnetics Laboratory of the Engineering Experiment Station, Georgia Institute of Technology, for the NASA Marshall Space Flight Center, Huntsville, Alabama. This represents a final technical report of a study of high accuracy antenna measurement methods applicable to the Solar Power Satellite (SPS) Subarrays. Contract technical monitor was R. A. Inmann, S & E, Electronics and Control Laboratory. Report authors are D. J. Kozakoff and J. M. Schuchardt.

The following individuals are recognized for their valuable contributions: Dr. E. B. Joy and C.E. Ryan of Georgia Tech in the area of near-field measurement techniques; J. L. Detwiler and S. D. Davis of Scientific Atlanta in the area of antenna positioners and electronics; P. F. Wacker^{*} of NBS; and B. L. Ulich of the University of Arizona for antenna gain calibration techniques; and W. Finnel of NASA MSFC in the area of SPS system philosophy.

The views and conclusions contained in this document are those of the authors and should not be interpreted as necessarily representing the official policies, either expressed or implied, of the NASA Marshall Space Flight Center.

* Recently retired

ABSTRACT

The relatively large antenna subarrays (tens of meters) to be used in the Solar Power Satellite (SPS), and the desire to accurately quantify antenna performance, dictate the requirement for specialized measurement techniques. An investigation conducted at the Georgia Institute of Technology and reported herein has quantified the error contributors associated with both far-field and near-field antenna measurement concepts. As a result, instrumentation configurations with measurement accuracy potential were identified. In every case, advances in the state-of-the-art of associated electronics were found to be required. Relative cost tradeoffs between a candidate far-field elevated antenna range and near-field facility were also performed.

TABLE OF CONTENTS

<u>Section</u>	<u>Page</u>
FOREWORD	iv
ABSTRACT	v
1.0 INTRODUCTION	1
2.0 MEASUREMENTS ERROR BUDGET	4
3.0 FAR-FIELD TECHNIQUES	6
3.1 Far-Field Error Budget Considerations	6
3.2 Ground Reflection Range	6
3.3 Elevated Range	12
3.4 Power Density Considerations	12
4.0 POSITIONER CONSIDERATIONS	19
5.0 MEASUREMENT ELECTRONICS	29
5.1 Error Budget for Electronics	29
5.2 System Configuration	29
6.0 NEAR FIELD TECHNIQUES	32
6.1 General Considerations	32
6.2 Scanner Considerations	34
7.0 COST TRADEOFFS	39
7.1 Far-Field Facility Concept and Cost Estimate	39
7.2 Near-Field Facility Concept and Cost Estimate	39
8.0 CONCLUSIONS	47
9.0 REFERENCES	48
Appendix A. Computed Fresnel Reflection Coefficient for Ground Reflection Range	50
Appendix B. Ground Reflection Range Vertical Field Intensity Distribution at Receive Site	54
Appendix C. Facility Cost Estimate Detail Breakdown	67
Appendix D. Subarray Weight Estimates	72
Appendix E. Vertical Field Intensity at Receive Site for Mountain Top to Mountain Top Range	76

LIST OF ILLUSTRATIONS

<u>Figure</u>	<u>Page</u>
1. Reference Antenna Subarray Configuration	2
2. Definition of Radiation Efficiency	3
3. Measurement Gain Loss Due to Quadratic Phase Error	8
4. Ground Reflection Range Concept	10
5. Ground Reflection Range Geometry Relations	11
6. Elevated Antenna Range Concept	13
7. Radiation Power Pattern Footprint for R = 500 m (0.31 miles)	15
8. Radiation Power Pattern Footprint for R = 1,035 m (0.64 miles)	16
9. Radiation Power Pattern Footprint for R = 2,100 m (1.3 miles)	17
10. Radiation Power Pattern Footprint for R = 5,000 m (3.1 miles)	18
11. Definition of Fractional Beam Power	20
12. Subarray Fractional Beam Power (0 - 1.5 degrees)	21
13. Subarray Fractional Beam Power (0 - 20 degrees)	22
14. Quantification of RDP Sample Accuracy Required	23
15. Antenna Positioner Mechanism for Far-Field SPS Antenna Pattern Measurements	28
16. Measurement Equipment Block Diagram	31
17. Near-Field Measurements Equipment Block Diagram	33
18. Planar Scanner Mechanism Concept for Subarray Near-Field Measurements	35
19. Cylindrical Scanner Concept for Subarray Near-Field Measurements	36
20. Planar Scanner Mechanism Concept for Mechanical Module Near-Field Measurements	38
21. Mountain Top to Mountain Top Far-Field Facility Concept (600 ft. height, 6-9 mile range)	40
22. Receive Site Detail for Far-Field Facility Concept	41
23. Transmit Site Detail for Far-Field Facility Concept	42
24. Planar Near-Field Measurement Facility Concept	44

LIST OF TABLES

<u>Table</u>		<u>Page</u>
1.	Measurements Error Budget	5
2.	Antenna Range Measurements Error Sub-budget	7
3.	Summary of Antenna Gain Calibration Methods	9
4.	Elevated Antenna Range Relations for Equal Transmit and Receive Antenna Heights	14
5.	Subarray Pattern Measurement Criteria	24
6.	Summary of Antenna Positioner Requirements	25
7.	Summary of State-of-the-Art in Positioner Performance	26
8.	Error Sub-budget for Receiver Electronics	30
9.	Cost Summary for Far-Field Facility	43
10.	Cost Summary for Near-Field Facility	46

1.0 INTRODUCTION

The SPS transmit antenna array described in the Reference System Report [1] is approximately 1-kilometer in diameter and composed of 7,220 uniformly illuminated square subarrays 10- by 10-meters in size as illustrated in Figure 1. The 10- by 10-meter subarray is the lowest level of phase control for phase steering of the array. Antenna illumination aperture weighting is achieved by utilizing subarrays with a different number of 1 kilowatt klystrons. For instance, at the central portion of the array, subarrays with 32 klystrons are used while at the outer edges of the array, subarrays with 4 klystrons are employed. These relatively large subarray apertures, small half-power beamwidths, and the desire to accurately quantify antenna performance dictate the requirement for specialized measurements techniques.

The emphasis of the high accuracy antenna measurements task reported herein was to study techniques to measure subarray radiation efficiency. Since klystrons, or solid state power modules in alternate designs, are an integral part of the subarray, the radiation efficiency definition shown in Figure 2 was adopted. That is, radiation efficiency is defined as the ratio of RF beam power to dc power to the klystrons. By use of power output monitors at each klystron, quantification of klystron and antenna structure radiation efficiency may be obtained.

Specific objectives of this study include the following:

- 1) For 10-meter square subarray panels, quantify considerations for measuring power in the transmit beam* and radiation efficiency to $\pm 1\%$ (± 0.04 dB) accuracy.
- 2) Evaluate measurement performance potential of far-field elevated and ground reflection ranges and near-field techniques.
- 3) Identify the state-of-the-art of critical components and/or unique facilities required.
- 4) Perform relative cost tradeoffs between candidate far-field and near-field facility concepts.

* Total klystron transmit power is 32 kW per subarray.

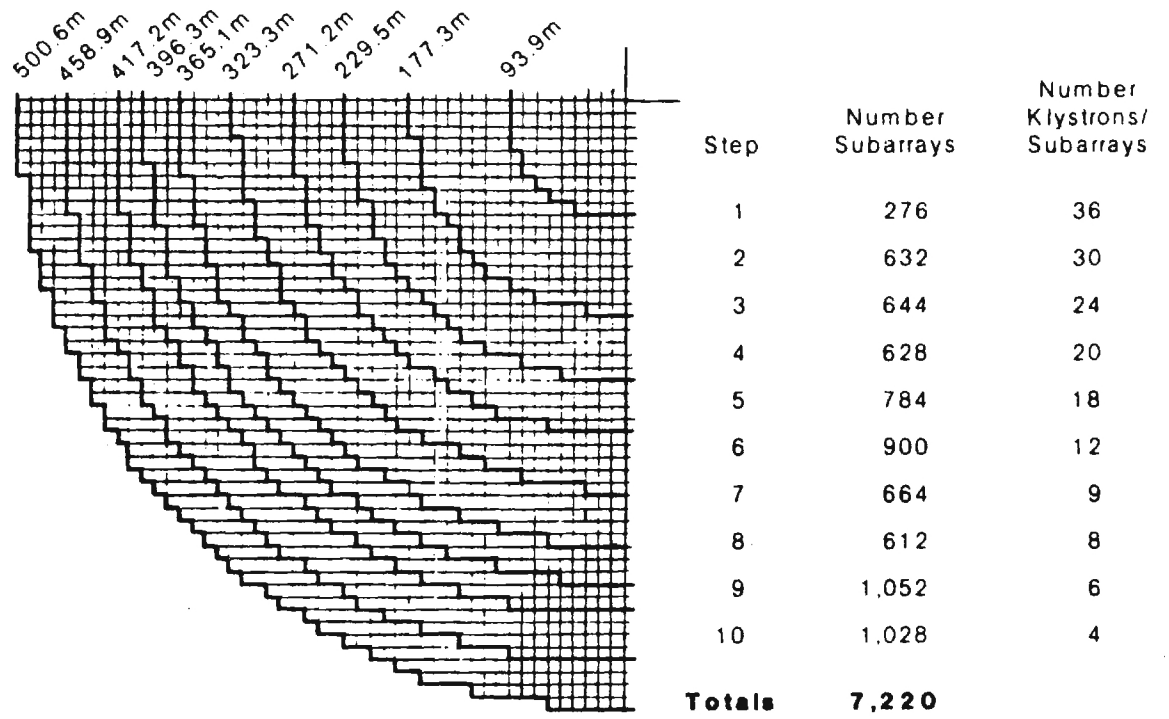
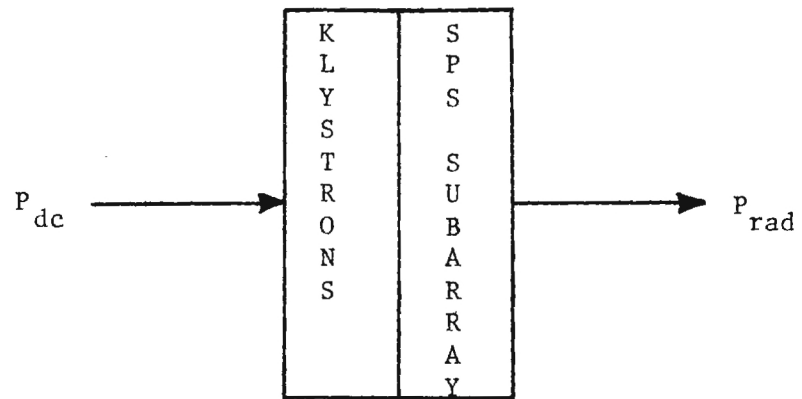

Figure 1. Reference Antenna Subarray Configuration (only one quadrant shown)



$$\eta = \frac{P_{rad}}{P_{dc}} ; \text{ where } P_{rad} = \text{RF Power in Main Beam}$$

Figure 2. Definition of Radiation Efficiency

2.0 MEASUREMENTS ERROR BUDGET

In general, the RF and physical environment and the electronic instrumentation all contribute to the overall measurement error. Ideally, the RF source is stable in amplitude and frequency, the transmitted wave arrives at the receiver as a true plane wave free of objectionable reflections, and the atmospheric effects are negligible. The receiver must be ideal and error free, and the gain antenna reference is accurately known. In the real world, one must deal with the errors which occur as the instrumentation departs from the ideal performance listed above.

For SPS subarray antenna pattern measurements, the critical error sources have been quantified into four categories shown in Table 1. The objective of this investigation is controlling these error sources to yield an overall gain uncertainty of ± 0.04 dB. Because of the large size of an SPS subarray (81.67-wavelengths at 2.45 GHz), antenna range effects are given the largest allowance in the error budget. The errors allocated to transmitter/receiver sources require advances in state-of-the-art of associated microwave electronics. However, even with currently available equipment, because of single frequency operation, and the fact that receiver and transmitter are phase-locked and thermally stabilized, errors can be accurately controlled. Use of a microcomputer will permit error compensation of such factors as the nonlinearity of receiver and detector.

Controlling the antenna structure for measurement will require developing a cradle assembly that will hold the antenna rigid. Preliminary weight estimates indicate approximately 2.5 tons for a prototype subarray assembly. Ambient temperature, solar energy and wind effects can be controlled somewhat by selecting the measurement time period. However, unique test facilities are anticipated. For instance, shielding from the adverse external parameters listed above can be achieved through use of a large dome radome.

Antenna measurements can be made with the test antenna either receiving or transmitting because of the reciprocity theorem. However, since in this case the SPS subarray is transmitting and the goal is to determine power in the transmit beam via beam integration, unique problems arise. The technical issues will be addressed in the following subsections.

Table 1. Measurements Error Budget

ERROR SOURCE	COMPONENTS	ALLOWABLE VALUE	COMMENTS
ANTENNA RANGE	FIELD UNIFORMITY QUADRATIC PHASE ERROR EXTRANEIOUS REFLECTIONS STANDARD GAIN ANTENNA UNCERTAINTY ATMOSPHERIC EFFECTS AXIAL RATIO	0.036 dB	AN ADEQUATE GAIN STANDARD HAS NOT YET BEEN IDENTIFIED REFERENCE RECEIVER MUST BE NORMALIZE EFFECTS OF ATMOSPHERE
STRUCTURAL/ ENVIRONMENTAL	SPS ANTENNA RIGIDITY/ STABILITY POSITIONER ERROR WIND LOADING/THERMAL	0.01 dB	WIND LOADING/THERMAL CAN BE CONTROLLED BY RADOME OVER TEST ANTENNA
TRANSMITTER	AMPLITUDE STABILITY FREQUENCY STABILITY	0.01 dB	PHASE LOCKED TECHNIQUES AND TEMPERATURE STABILIZATION MUST YIELD AMPLITUDE STABILITY OF 0.007 dB
RECEIVER	PRECISION ATTENUATOR UNCERTAINTY REFERENCE INPUT PHASE/ AMPLITUDE ERRORS SIGNAL TO NOISE RATIO FREQUENCY STABILITY DYNAMIC RANGE DETECTOR LINEARITY VSWR	0.01 dB	ATTENUATOR CALIBRATED TO 0.005 dB S/N RATIO MUST EXCEED 40 dB DETECTOR CALIBRATION CAN EXCEED 0.005 dB VSWR KEPT BELOW 1.05 dB

TOTAL RSS = 0.04 dB

3.0 FAR-FIELD TECHNIQUES

3.1 Far-field Error Budget Considerations

The predominant error contributors for far-field measurements are 1) field nonuniformity due to ground reflection, 2) gain loss due to quadratic phase error (near-field effects), and extraneous reflections. The National Bureau of Standards has investigated error budgets associated with far-field measurements [3]. For SPS, an adopted far-field antenna range error sub-budget is shown in Table 2. Figure 3 plots the measurement gain loss due to quadratic phase error for a 10- by 10-meter SPS subarray panel. The large size of the subarray dictates a far-field criteria of greater than $6 D^2/\lambda$ to maintain quadratic phase error loss below 0.01 dB.

A constraint on the absolute measurement accuracy of a far-field facility is calibration accuracy of a gain standard antenna. Commonly used methods of obtaining an antenna gain standard appear in references [3] through [7]; a summary of approximate measurement accuracy of the various techniques appears in Table 3. Here, the calibration accuracy of even the best methods are almost an order of magnitude larger than desired for SPS antenna measurements. With the availability of a high stability microwave receiver to be discussed later in this report, it is anticipated that gain calibration to ± 0.02 dB can be accomplished.

3.2 Ground Reflection Range

Consideration was given to use of a ground reflection range facility as illustrated in Figure 4. Here, transmit and receive tower heights are selected so that the reflection from the ground adds in phase to the direct ray path. Calculation of ground reflection coefficients in Appendix A show values very near unity for typical range geometry. A negative feature is that a relatively large range is required to obtain a sufficiently flat amplitude wavefront in the vicinity of the receive antenna.

Figure 5 relates the transmit and receive tower heights as a function of range. Under the constraint of a minimum and maximum tower height of 20 and 100 feet, respectively, the minimum range of 3 miles based on near-field criteria; the shaded area indicates regions where satisfactory operation may be obtained. The criteria for a sufficiently flat amplitude wavefront over

Table 2. Antenna Range Measurements Error Sub-budget

<u>ERROR COMPONENT</u>	<u>ALLOWABLE VALUE</u>	<u>COMMENTS</u>
Field Uniformity	0.015 dB	Maximum amplitude taper at edge of SPS subarray approx. 0.04 dB
Quadratic Phase Error	0.010 dB	Requires range greater than $6 D^2/\lambda$
Standard Gain Antenna Uncertainty	0.020 dB	Gain standard needs to be developed
Atmospheric Effects	0.005 dB	Atmospheric effects cancelled by reference
VSWR	0.005 dB	VSWR loss calibrated out
Extraneous Reflections	0.025 dB	Extraneous reflections -57 dB down
	<hr/>	
RSS Subtotal	0.037 dB	

10 Meter Square
SPS Subarray
at 2.45 GHz

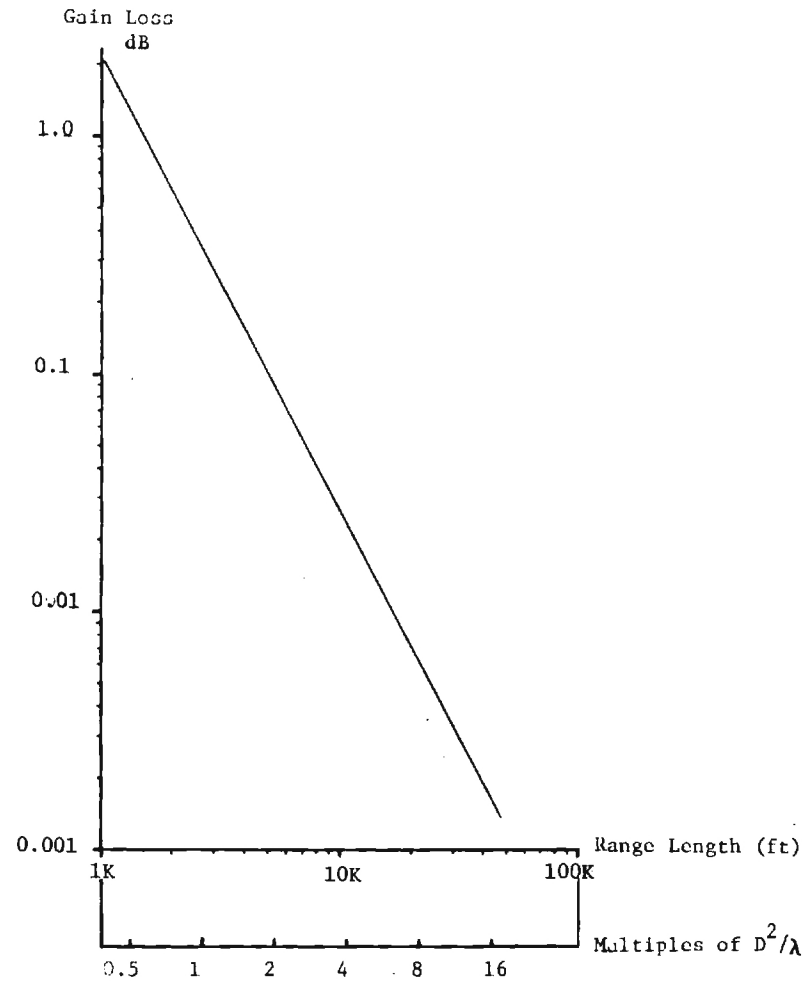

Figure 3. Measurement Gain Loss due to Quadratic Phase Error

Table 3. Summary of Antenna Gain Calibration Methods

METHOD	FACILITY REQUIRED	APPROXIMATE ACCURACY	COMMENTS
COMPUTATION	NONE	± 0.5 dB	UNACCEPTABLE ACCURACY
TWO-ANTENNA METHOD	ELEVATED RANGE	± 0.2 dB	NEAR FIELD CORRECTION REQUIRED
THREE-ANTENNA METHOD	ELEVATED RANGE	± 0.2 dB	NEAR FIELD CORRECTION REQUIRED
EXTRAPOLATION METHOD	ELEVATED RANGE	± 0.1 dB	GOOD CANDIDATE; SHORT DISTANCES AND LOW TOWER HEIGHTS REQUIRED
TWO-ANTENNA METHOD	GROUND REFLECTION RANGE	± 0.3 dB	FIELD NONUNIFORMITY CORRECTION REQUIRED
THREE-ANTENNA METHOD	GROUND REFLECTION RANGE	± 0.3 dB	FIELD NONUNIFORMITY CORRECTION REQUIRED
RADIOMETRIC METHOD	ANECHOIC CHAMBER	± 0.1 dB	POSSIBLE CANDIDATE; MEDIUM GAIN ANTENNAS ONLY
NEAR-FIELD MEASUREMENT	ANECHOIC CHAMBER	± 0.15 dB	GOOD CANDIDATE

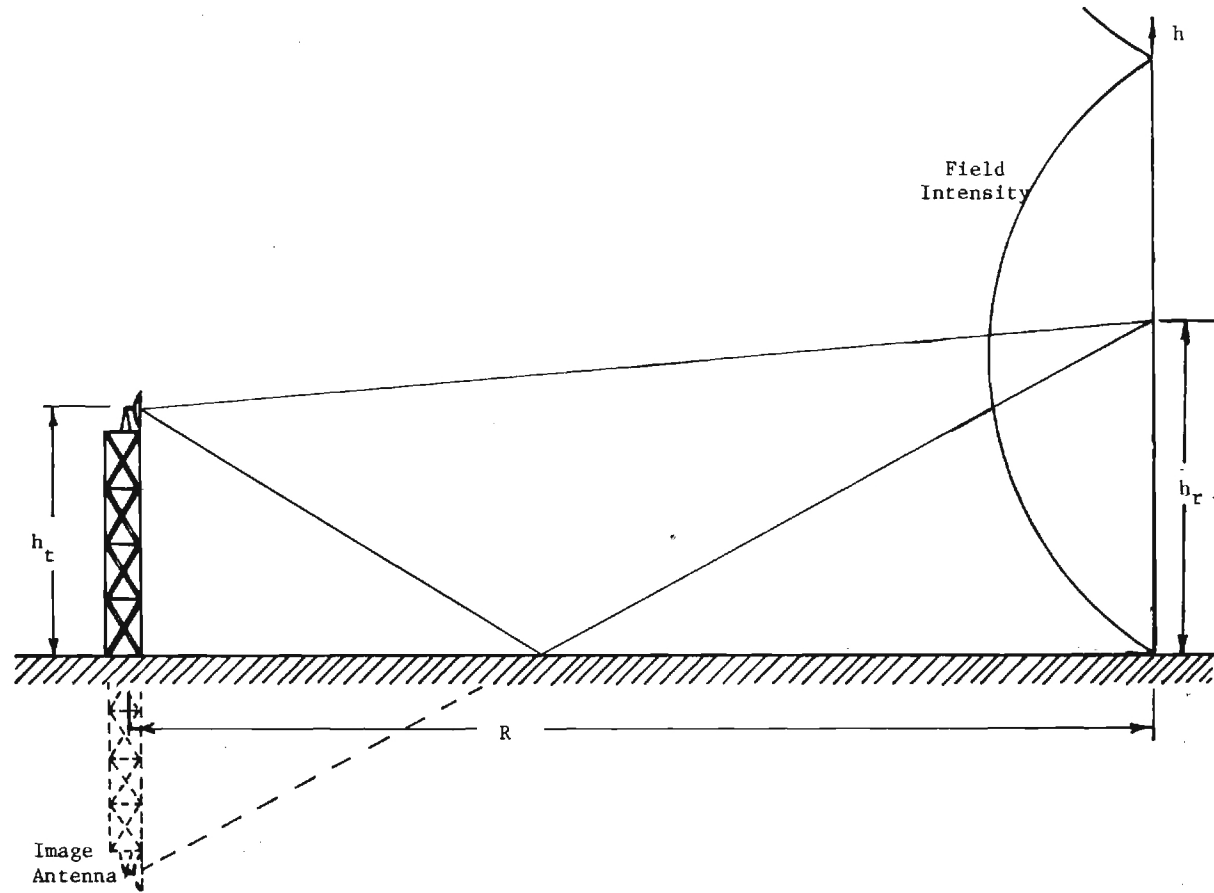
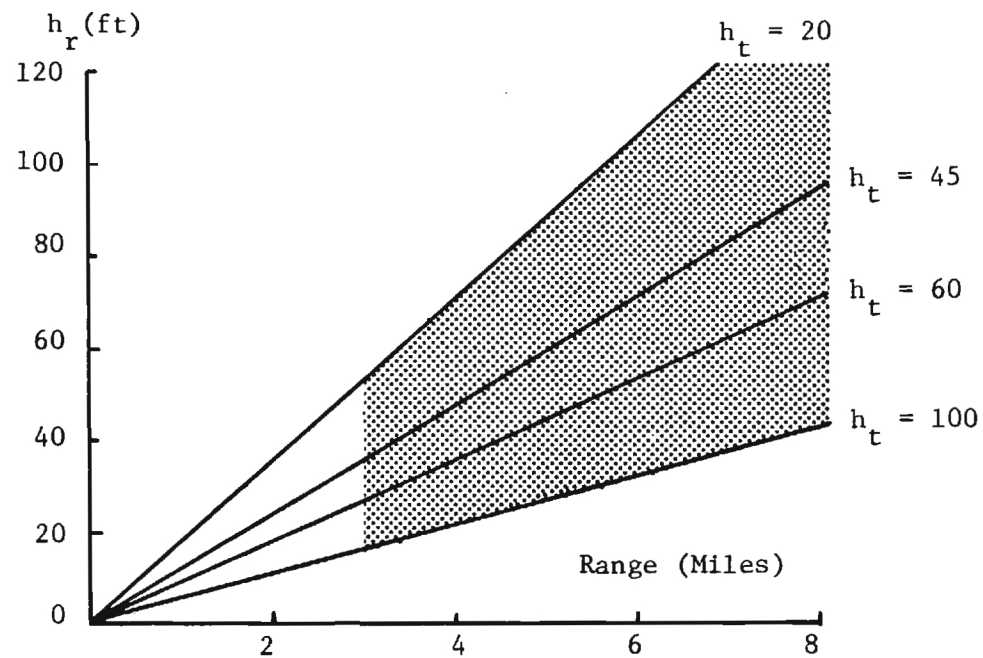

Figure 4. Ground Reflection Range Concept



NOTE: Darkened area is allowable operating region for SPS subarray pattern measurements.

h_r = Receive Antenna Height
 h_t = Transmit Antenna Height

Figure 5. Ground Reflection Range Geometry Relations

the test zone may be deduced from the relationship shown in Figure 6. Here, it is seen that a maximum field nonuniformity error of 0.015 dB as allocated in the antenna range error sub-budget corresponds to a maximum illumination falloff at the receive antenna of 0.04 dB. Initial calculations indicate the performance of a 4-mile ground reflection range with receive and transmit tower heights of 30 and 70 feet, respectively, provided a wavefront within 0.1 dB over a 10-meter zone, but only with use of high efficiency absorber barricades at the midrange point. A summary of calculation data appear in Appendix B.

Use of a smaller receive antenna makes the utilization of a ground reflection range credible. However, the concept was precluded for further study because of the relatively high tower heights required in the far-field.

3.3 Elevated Range

Field nonuniformity can be controlled via an elevated range concept where the receive antenna null is placed at the midpoint reflection point as depicted in Figure 6. Tradeoff calculations indicate the required tower heights for elevated range distances greater than $6 D^2/\lambda$ are not practical, however, consideration for a mountain top to mountain top range with an elevation of 600 feet and a measurement range of 7 miles appears very attractive. A summary of the elevated range tradeoff calculations appear in Table 4.

3.4 Power Density Considerations

Assuming the maximum klystron transmit RF power of 32 kW per sub-array, a consideration was the power densities in local terrain between transmit and receive site to assess the hazard to personnel. At a range in the order of 0.31-miles the antenna footprint illustrated in Figure 7 has a peak power density of 179 mW/cm^2 . (The considered safety limit in the United States is 10 mW/cm^2). Figures 8 and 9 plot the radiation power pattern footprint for $R = 0.64$ and 1.3 miles, respectively. Power densities approach the safe limit at about 1-mile. Finally, Figure 10 illustrates power density at 3.1 miles where the peak level (1.86 mW/cm^2) is well within the safe limit.

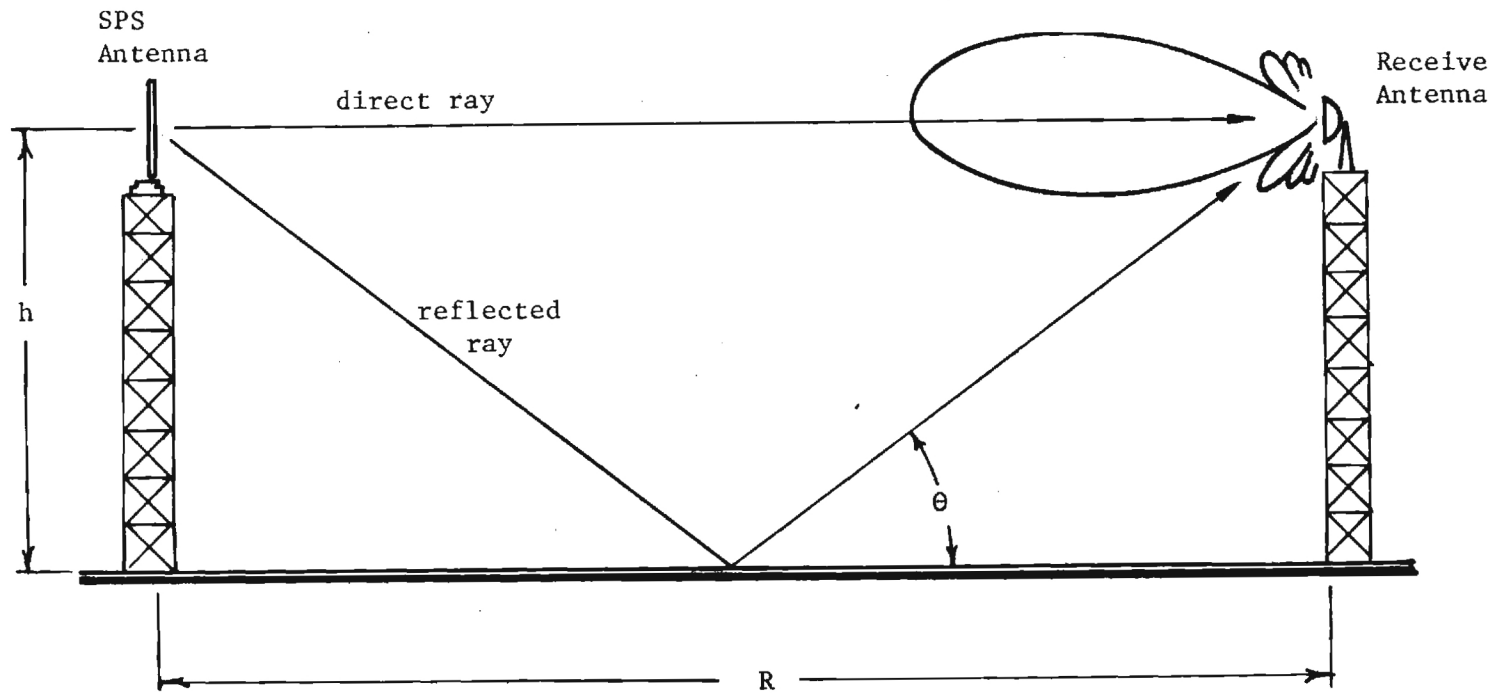

Figure 6. Elevated Antenna Range Geometry

Table 4. Elevated Antenna Range Relations for Equal Transmit and Receive Antenna Heights

Antenna Height h (feet)	Antenna Diameter (feet)	Half Power Beamwidth (degrees)	1st Null Position (degrees)	Required Range R (miles)	Comments
100	4	7.0	9.3	0.23	"h" is Highest Practical Tower Height
	8	3.5	4.7	0.46	
	12	2.3	3.1	0.70	
	15	1.85	2.5	0.87	
600	4	7.0	9.3	1.39	Mountain Top to Mountain Top Range
	8	3.5	4.7	2.76	
	12	2.3	3.1	4.20	
	15	1.85	2.5	7.04	

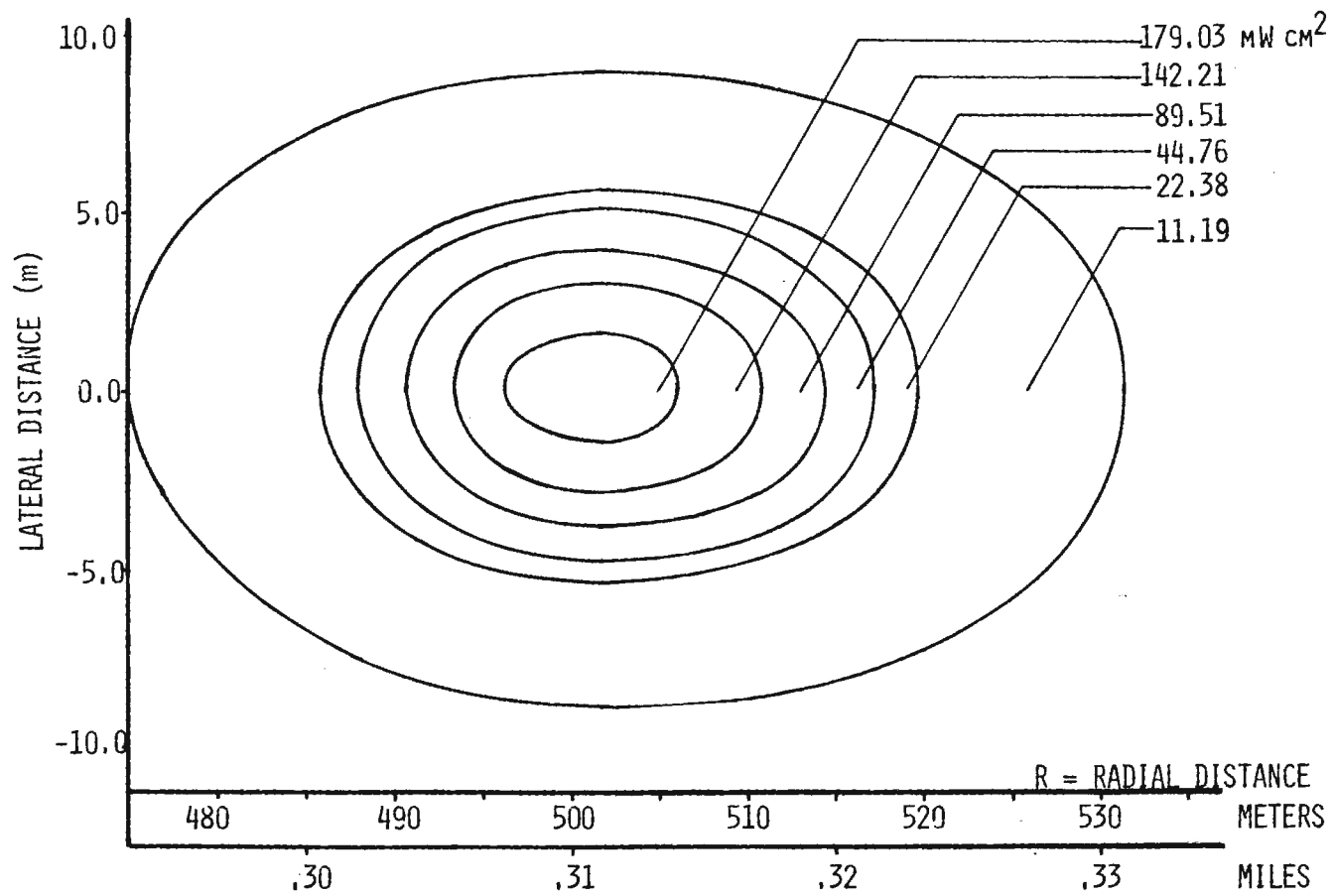

Figure 7. Radiation Power Pattern Footprint for R = 500 m (0.31 miles)

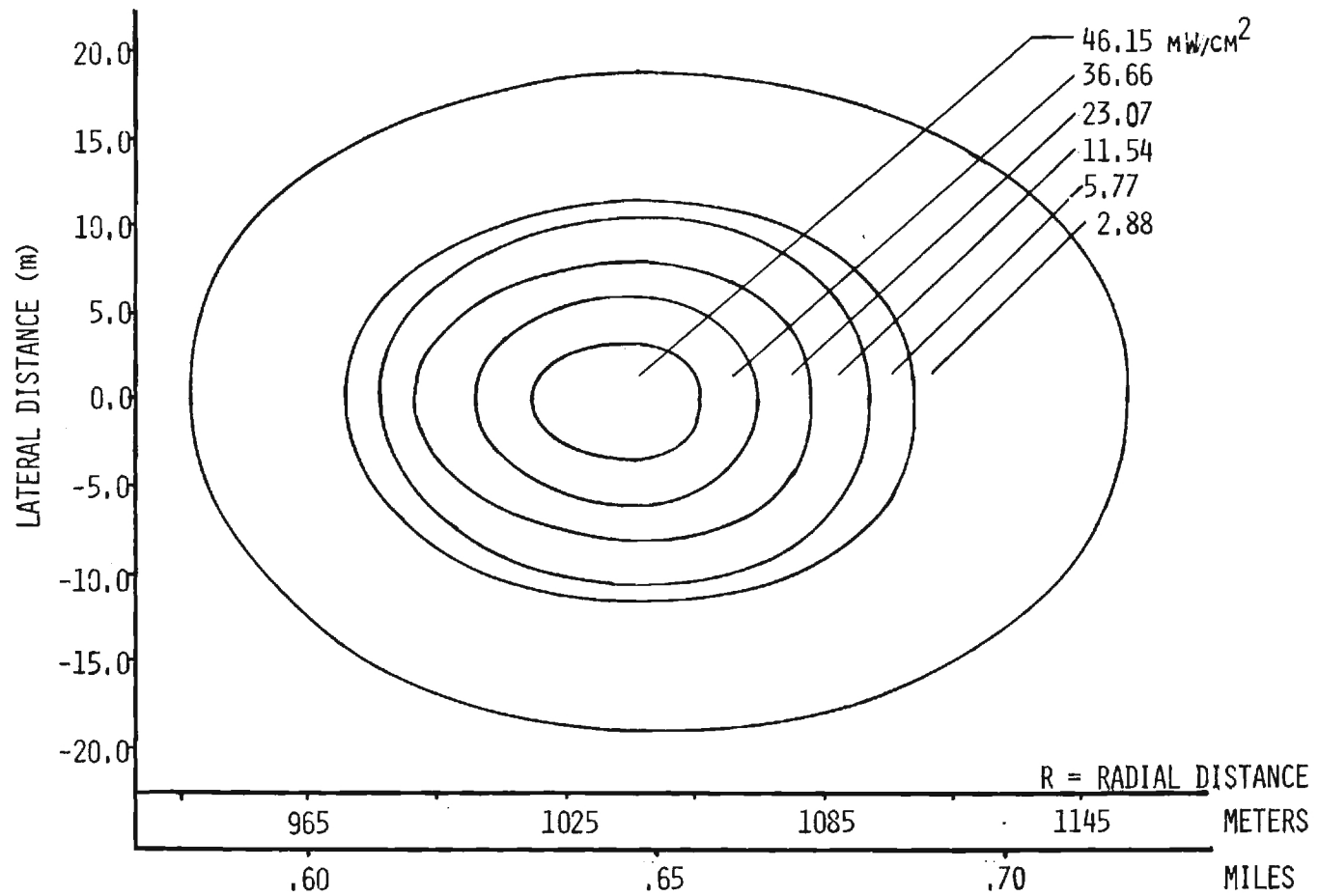

Figure 8. Radiation Power Pattern Footprint for R = 1,035 m (0.64 miles)

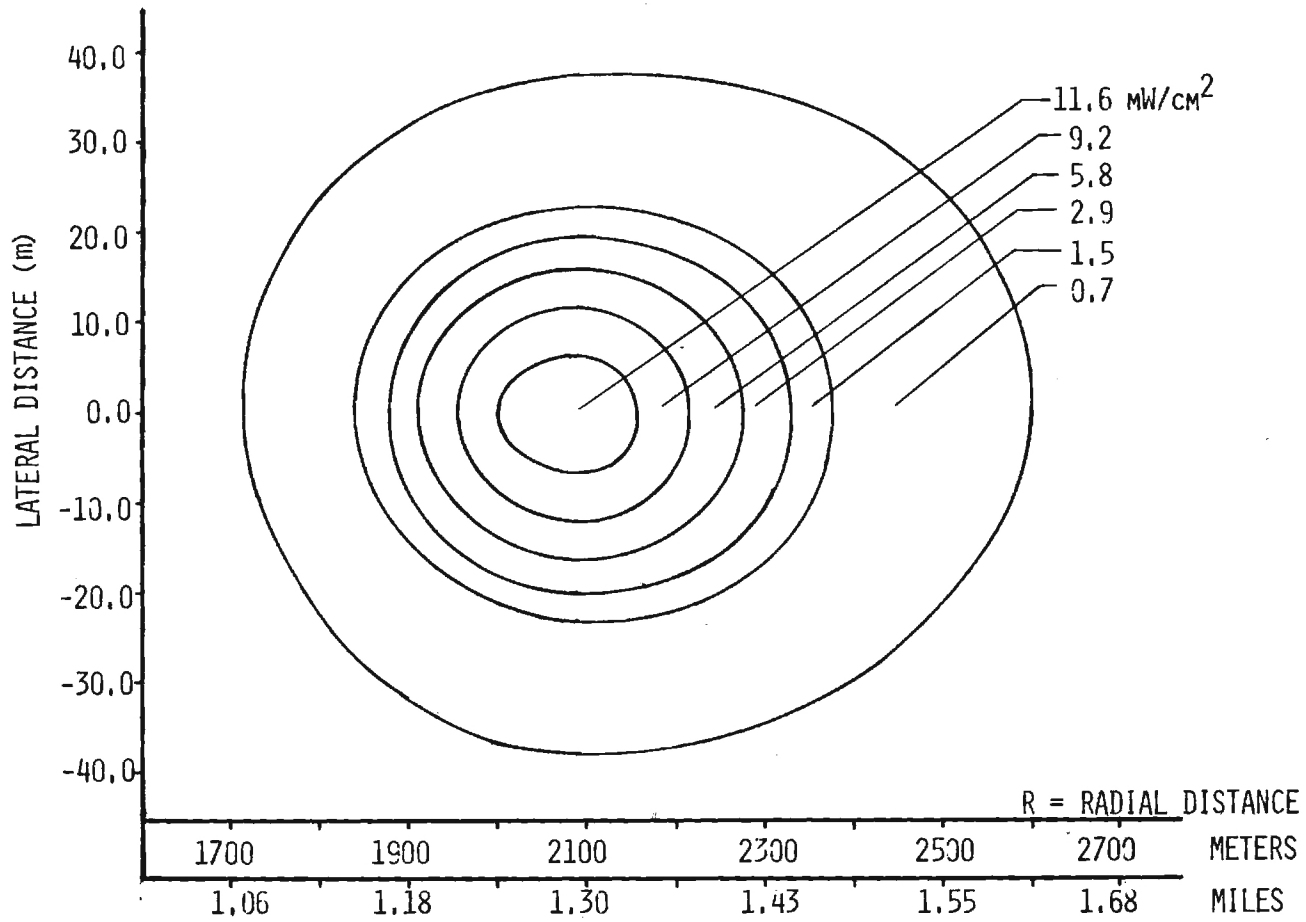

Figure 9. Radiation Power Pattern Footprint for R = 2,100 m (1.3 miles)

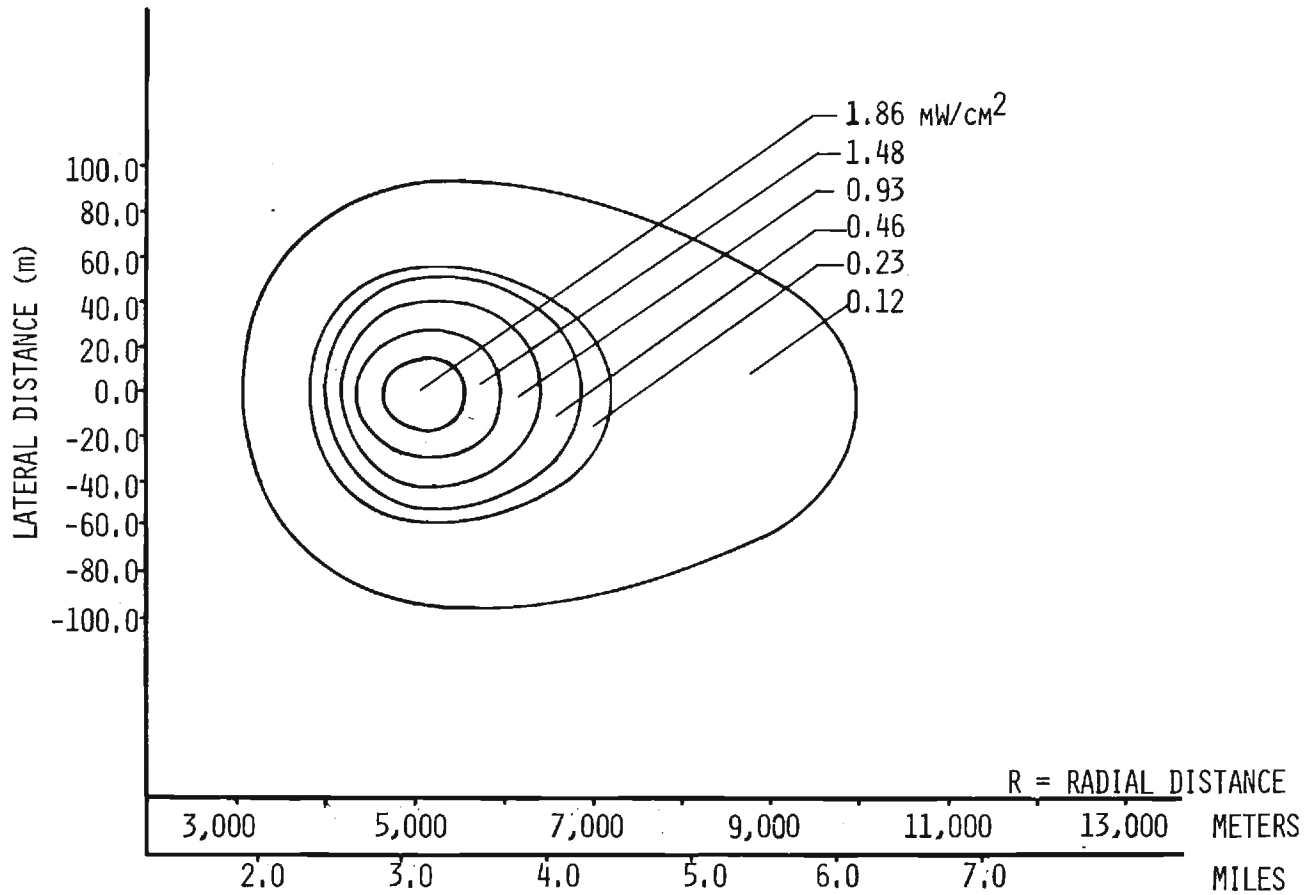

Figure 10. Radiation Power Pattern Footprint for R = 5,000 m (3.1 miles)

4.0 POSITIONER CONSIDERATIONS

The antenna positioner considerations must include weight handling capability, positioning accuracy, and scan limit requirements. In Appendix D, an estimate of SPS subarray weight of 2.5 tons was arrived at on the basis of an array constructed of standard WR340 aluminum waveguide. An advanced technology array consisting of light weight Raytheon waveguide plus Varian 4k3SK klystrons was found to have approximately the same weight.

The required positioner scan limits were evaluated on the basis of fractional beam power as defined in Figure 11. The fractional power in the beam based on a uniformly illuminated 10-meter square aperture is plotted through 1.5 and 20 degrees in Figures 12 and 13, respectively. Here, it is seen that the main beam (± 0.312 degrees) encompasses approximately 79 percent of the transmitted energy. Based on these results, a concept was devised where a small angle positioner (SMAP) provides very accurate scan capability over a ± 1.5 degree sector for the purpose of beam integration. A larger gimbal arrangement provides coarse positioning over the complete ± 20 degree sector. Positioner hardware providing greater angular scan does not currently exist. From the plots of fractional beam power, approximately 89% of the total radiated power is accounted for within $\pm 1.5^\circ$ scan; over 99% of the power is radiated in the ± 20 degree sector.

Quantification of required positioner accuracy was achieved by studying the sample accuracy requirement for ± 0.04 dB beam power measurement accuracy illustrated in Figure 14. In Table 5, these results are applied to varied subarray sizes. For a 10-meter square subarray, it is seen that a 19-bit encoder is required for resolution to about 0.001 degrees.

Table 6 is a summary of the antenna positioner requirements. The large weight handling requirement and small angular accuracy requirements indicate that the positioner is a potential problem area based on units currently available. A survey was made of available antenna positioners, and is summarized in Table 7. The positional accuracy of off-the-shelf positioners is on the order of 0.005 degrees. Available positioner data indicate positioning of anything larger than the 10-meter subarray will not be

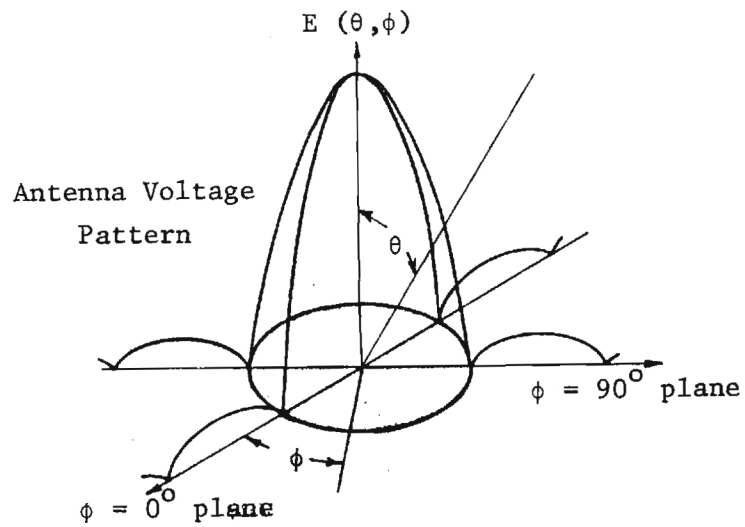

$$\text{Fractional Beam Power} = \frac{\int_0^{\theta_0} \int_0^{2\pi} E^2(\theta, \phi) \sin\theta \, d\phi d\theta}{\int_0^{\pi/2} \int_0^{2\pi} E^2(\theta, \phi) \sin\theta \, d\phi d\theta} \times 100$$

Figure 11. Definition of Antenna Beam Parameters

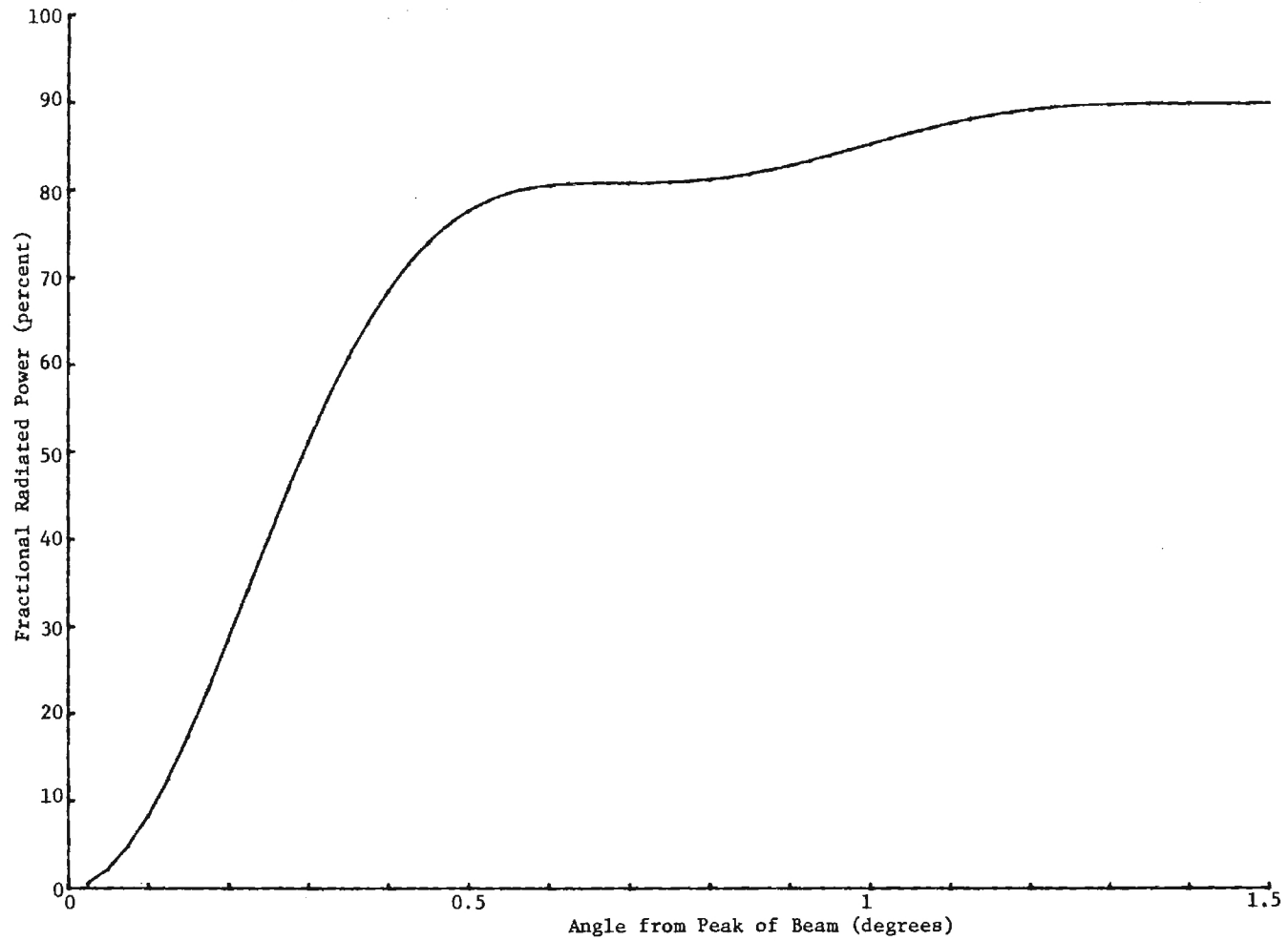

Figure 12. Subarray Fractional Beam Power (0 - 1.5 degrees)

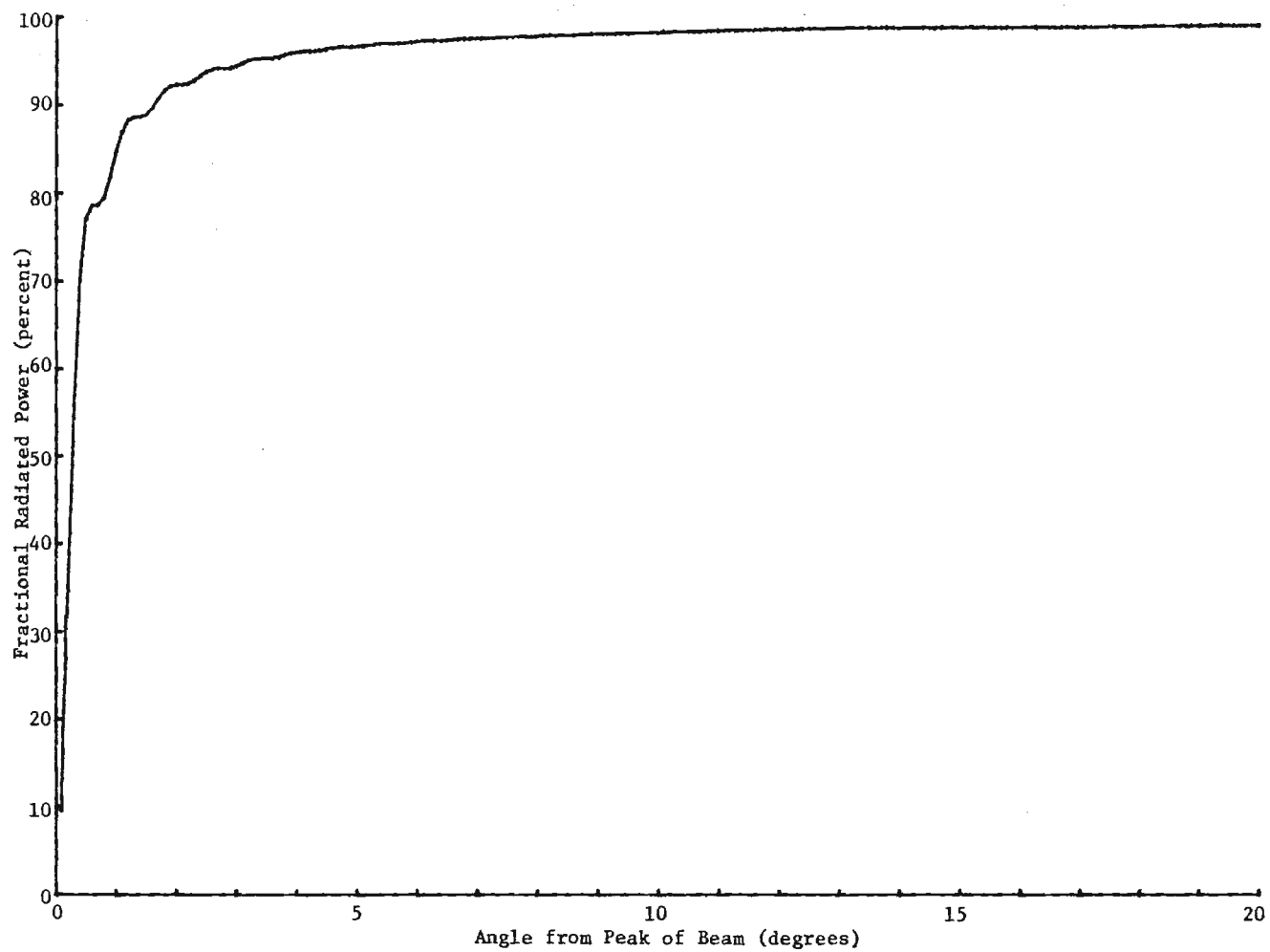
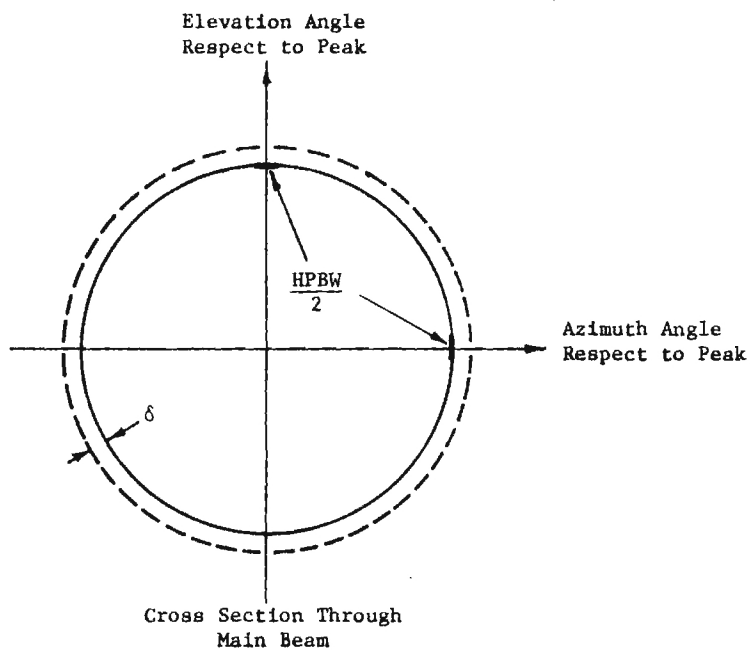

Figure 13. Subarray Fractional Beam Power (0 - 20 degrees)



Assuming power in the main beam is proportional to beam area, the δ corresponding to 1% power change is:

$$\pi \left(\frac{\text{HPBW}}{2} + \delta \right)^2 = 1.01 \pi \left(\frac{\text{HPBW}}{2} \right)^2$$

or

$$\delta = 0.005 \left(\frac{\text{HPBW}}{2} \right)$$

Figure 14. Quantification of RDP Sample Accuracy Required

Table 5. Subarray Pattern Measurement Criteria

Subarray Size (m)	Subarray Size (wavelengths)	Subarray HPBW* (deg)	Pattern δ for 1% Power Change (deg)	ENCODER Requirement (Bits)**	Data Array Size for ± 1.5 Degrees Square Raster***	Total Data Array Size (words)	Comments
1	8.167	6.24	0.016	16	188x188	35.344K	
3	24.502	2.081	0.0052	18	577x577	332.929K	
7	57.172	0.892	0.0022	19	1,364x1,364	1.86K	
10	81.67	0.624	0.0016	19	1,875x1,875	3.516M	Encoder Quantification to 0.00097 degrees
30	245.02	0.208	0.00052	21	5,770x5,770	33.293M	Encoder not Available
70	571.72	0.0892	0.00022	22	13,637x13,637	185.968M	Encoder not Available
100	816.7	0.0624	0.00016	23	18,750x18,750	351.562M	Encoder not Available

* Uniform illumination

** Quantification to approximately $\delta/2$

*** Sampled at $\delta/2$

Table 6. Summary of Antenna Positioner Requirements

WEIGHT

FOR SUBARRAY CONSTRUCTED OF STANDARD
WR-340 ALUMINUM WAVEGUIDE (0.98 LBS/FT),
NO KLYSTRONS 2.5 TONS

FOR LIGHT WEIGHT PROTOTYPE WAVEGUIDE
(11.8 LBS/M²), PLUS 50 VARIAN 4K3SK
KLYSTRONS AT 85 LBS EACH 2.7 TONS

ENCODER

TO PROVIDE 0.0018 - DEG, RESOLUTION
REQUIRED FOR 1% POWER MEASUREMENT ACCURACY 19 BITS

SCAN LIMITS

COMPATIBLE WITH MAIN LOBE BEAM POWER
PATTERN INTEGRATION ±1.5 - DEGREES
(AZIMUTH AND
ELEVATION)

Table 7. Summary of State-of-the-art in Positioner Performance

Scientific Atlanta Series**	Maximum Moment (kft-lb)	Estimated Moment Arm* (ft)	Maximum Subarray Wt.		Cost***		
			kibs	Tons	Elev./Az.	SMAP	Total
85	150	9.5	15.8	7.9	\$ 440K	\$400K	\$ 840K
45	75	7.5	10	5	\$ 111K	\$100K	\$ 211K

* Elevation over azimuth plus SMAP configuration.

** NOTE: the series 85 has a maximum vertical load limit of 25 tons.

*** November 1979 estimates.

possible, based on the weight projections.

A proposed state-of-the-art antenna positioner mechanism for far-field antenna measurements providing the required positioning accuracy is illustrated in Figure 15.

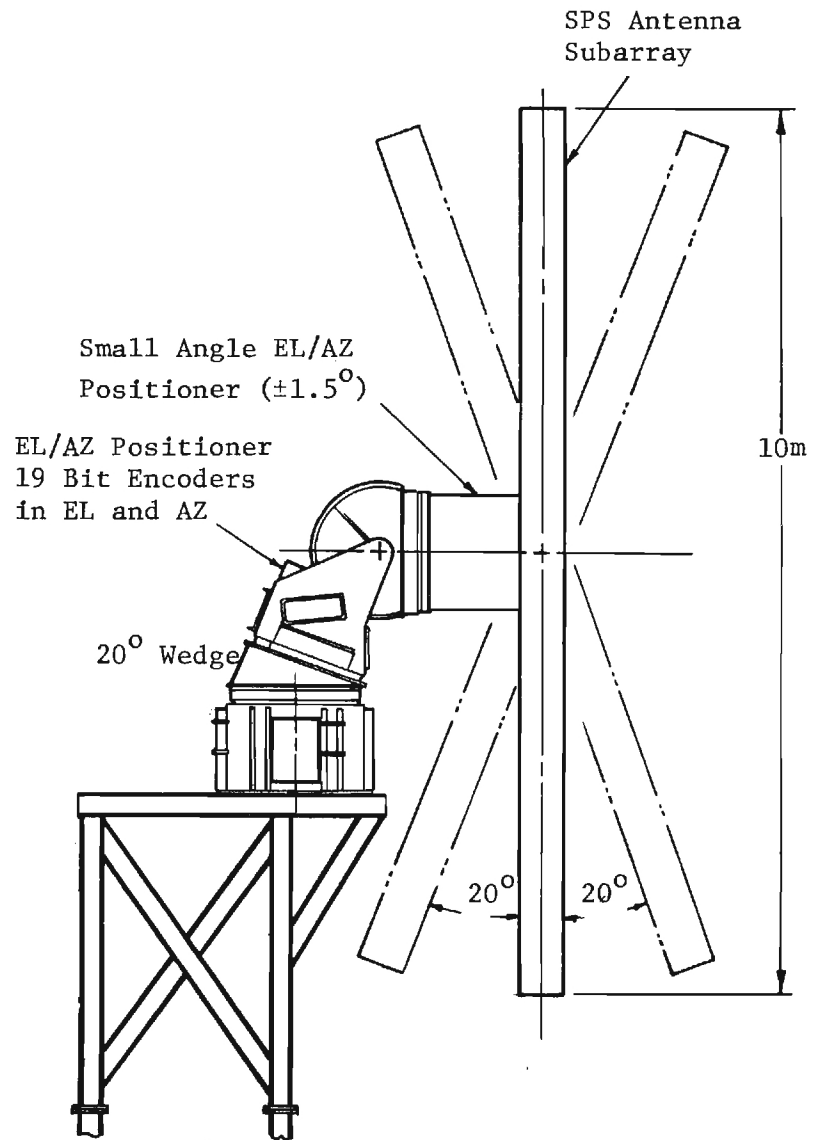

Figure 15. Antenna Positioner Mechanism for Far-Field SPS Antenna Pattern Measurements

5.0 MEASUREMENT ELECTRONICS

5.1 Error Budget for Electronics

An error sub-budget for receiver electronics is shown in Table 8. The state-of-the-art performance was based on available data for the Scientific Atlanta models 1711 and 1770 microwave receivers. The errors allocated to receiver sources in the SPS error budget are typically an order of magnitude smaller than the state-of-the-art performance and require advances in associated microwave electronics. However, even with currently available equipment, because of single frequency operation and the fact that receiver and transmitter are phase-locked and thermally stabilized, errors can be accurately controlled.

5.2 System Configuration

For SPS subarray antenna measurements, a proposed electronics measurements equipment block diagram is shown in Figure 16. Here, use of a microcomputer will permit error compensation of such factors such as non-linearity of receiver and detector. Use of a high precision amplitude reference permits absolute received power measurements. The system is phase locked and the atmospheric effects are normalized out. Key development areas for this concept are a precision calibrated microwave variable attenuator, The precision absolute amplitude reference source, and a precision calibrated standard gain antenna.

The availability of a computer compensated precision microwave receiver will permit advances in the state-of-the-art capability of calibrating standard gain reference antennas. The basic receiver system is applicable both to far-field and near-field measurements facilities.

Table 8. Error Sub-budget for Receiver Electronics

ERROR SOURCE	STATE-OF-THE-ART PERFORMANCE (1)	SPS ERROR BUDGET	COMMENTS
LINEARITY	0.05 dB/10 dB	0.005 dB	MICROCOMPUTER CALIBRATION REQUIRED
IF AMPLIFIER DRIFT	0.05 dB/°C	0.002 dB	TEMP. STABILIZATION AND MICROCOMPUTER CALIBRATION REQUIRED
CABLE LOSSES	0.2%/°C	0.002 dB	PRECISION AMPLITUDE REFERENCE WILL NORMALIZE CABLE LOSS VARIATIONS
CROSSTALK	0.1 dB FOR 40 DB DIFFERENCE BETWEEN CHANNELS	0.003 dB	MICROCOMPUTER COMPENSATION REQUIRED
AMPLITUDE RESOLUTION	0.1 dB OVER 80 DB DYNAMIC RANGE (2)	0.001 dB	17 BIT PARALLEL BCD RECEIVER OUTPUTS REQUIRED FOR 0.001 DB RESOLUTION
S/N RATIO	0.01 dB FOR S/N = 60 DB	0.005 dB	NARROW IF BW REQUIRED TO EXTEND DYNAMIC RANGE
LINE VOLTAGE VARIATION	0.02 dB FOR 1% CHANGE IN LINE VOLTAGE	0.001 dB	VOLTAGE REGULATION AND MICROCOMPUTER COMPENSATION REQUIRED
PRECISION IF/ RF ATTENUATORS	+ 0.2 dB FOR 10 DB STEPS	0.005 dB	MICROCOMPUTER COMPENSATION MAY BE REQUIRED
VSWR	0.15 dB FOR VSWR OF 1.3:1	0.002 dB	ALL VSWR'S MAINTAINED BELOW 1.05 AND/OR CALIBRATED OUT
	RSS TOTAL	0.01 dB	

NOTES: (1) DATA BASED ON S/A 1711 AND 1770 RECEIVERS

(2) DATA BASED ON S/A 1832A AMPLITUDE DISPLAY UNIT

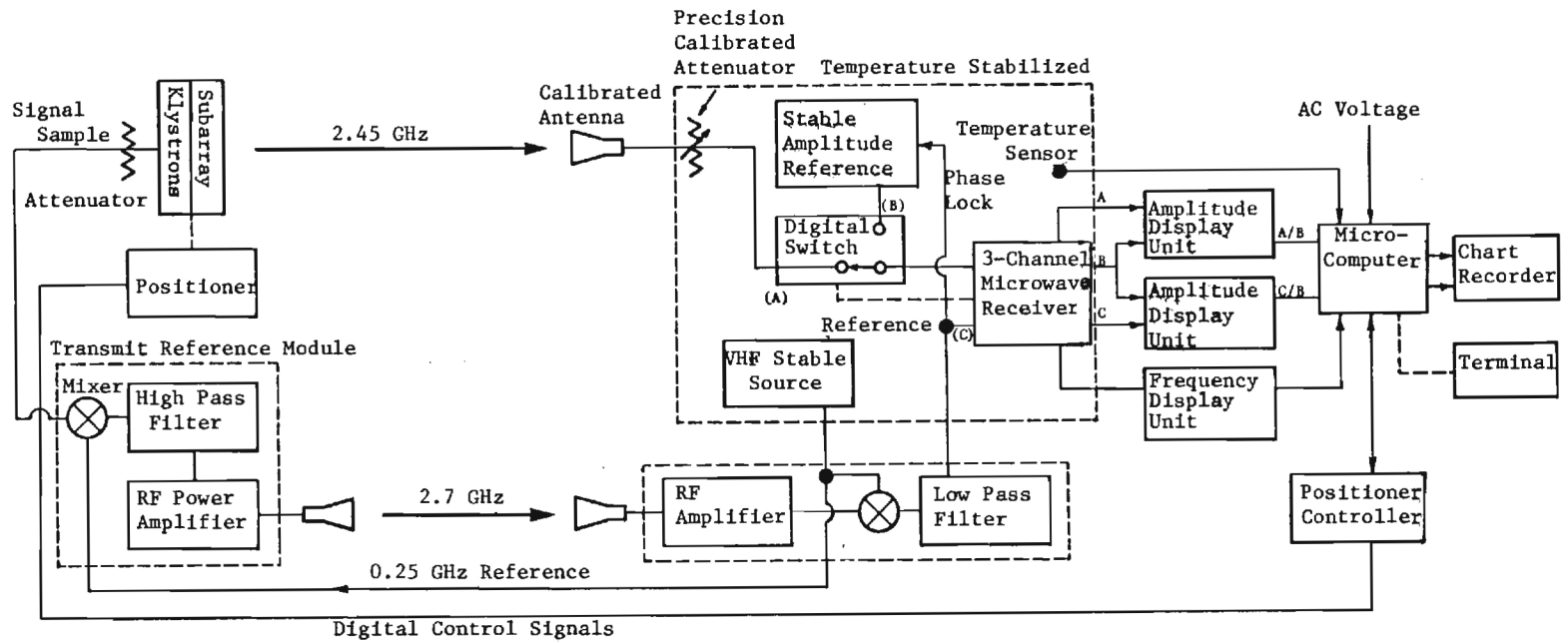

Figure 16. Measurement Equipment Block Diagram

6.0 NEAR-FIELD TECHNIQUES

6.1 General Considerations

Near-field techniques utilize a calibrated probe antenna to measure the amplitude and phase of the field close to the antenna aperture. Two orthogonally-polarized probes, or a single linear-polarized probe oriented in the vertical and horizontal directions are used, together with a probe compensation technique [8,9] to obtain the complete radiation characteristics of the antenna under test (AUT). This measurement procedure requires an automated facility capable of reading the measured data in digital form for the required computer processing.

The basic elements of a near-field measurements facility consist of a precision scanner mechanism, calibrated field probe, microwave receiver and digital computer. An equipment block diagram is shown in Figure 17. The planar near-field measurement technique is particularly attractive for SPS since the SPS subarray does not have to be moved during the measurement, i.e., only the probe antenna is moved. The approach can be implemented at high power levels and in an indoor facility permitting all weather operation.

Recent work at Georgia Tech has demonstrated that accurate antenna patterns can be obtained via near-field techniques [4,5]. The National Bureau of Standards has shown that for planar near-field scanning, the near-field derived patterns are more accurate than far-field measured patterns when considering all error sources involved [6].

Martin Marietta [12] has implemented an indoor planar near-field measurements facility capable of measurement of antennas up to 50-foot in diameter. The benefits of this facility include all weather operation, a thermally controlled environment (maintained within 2°F), and an RF anechoic environment. RCA has also implemented an indoor planar near-field facility for acceptance testing of the AN/SPY-1 phased array antenna for the AEGIS system [13].

In order to obtain accurate polarization information on the antenna pattern, the polarization characteristics of the measurement probe must be carefully characterized over the maximum possible dynamic range. Work at

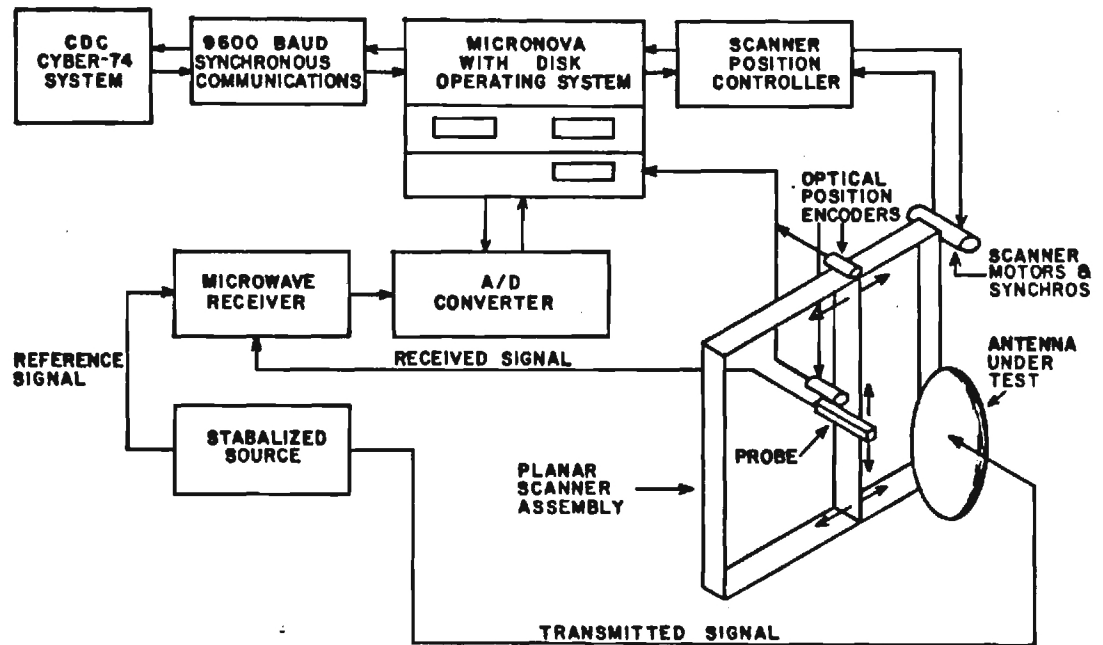

Figure 17. Near-Field Measurements Equipment Block Diagram

RCA [14] has also indicated that careful probe polarization design is necessary too if a very accurate gain determination is required. For instance, assuming an SPS antenna polarization ratio of 30 dB, a probe polarization ratio of 20 dB will result in a gain measurements error of approximately 0.25 dB. Thus, a very stringent requirement is placed on probe polarization ratio; a requirement of 30 dB, or better, is anticipated.

6.2 Scanner Considerations

In order to obtain a complete representation of the antenna pattern from a planar or cylindrical near-field scan, the field is normally sampled at $1/2$ wavelength intervals along the linear scan dimension. If the antenna under test is electrically large, the required Fourier transform processing can become burdensome. However, it has been shown that the sample spacing can be increased by almost an order of magnitude if only the main-beam and first sidelobes are to be defined [10,15].

A planar scanner concept applicable to SPS subarray antenna measurements is shown in Figure 18. An investigation of error contributors to near-field measurements [16] has indicated that the required probe X-, Y- and Z-positioning accuracy is $\lambda/200$ for pattern accuracy compatible with SPS measurement objectives.

Near-field measurements can also be implemented by employing cylindrical or spherical probe scanning. A previous study performed by Georgia Tech for NASA indicated that the cylindrical near-field technique is attractive for the measurement of electrically and physically large ground station antennas [16]. A cylindrical near-field scanner concept for subarray near-field measurements is shown in Figure 19. However, in the spherical technique, it is necessary to move the AUT while holding the probe fixed. In the case of SPS, spherical near-field scanning cannot be used because of the difficulty of gimbaling the heavy subarray in order to scan over a full sphere. However, planar and cylindrical scanning concepts are applicable. Either system has potential to be implemented outdoors, however, the effects of thermal changes on scanning mechanism and instrumentation and the fact that an outdoor facility is subject to environmental conditions, makes an indoor near-field facility far more attractive and practical.

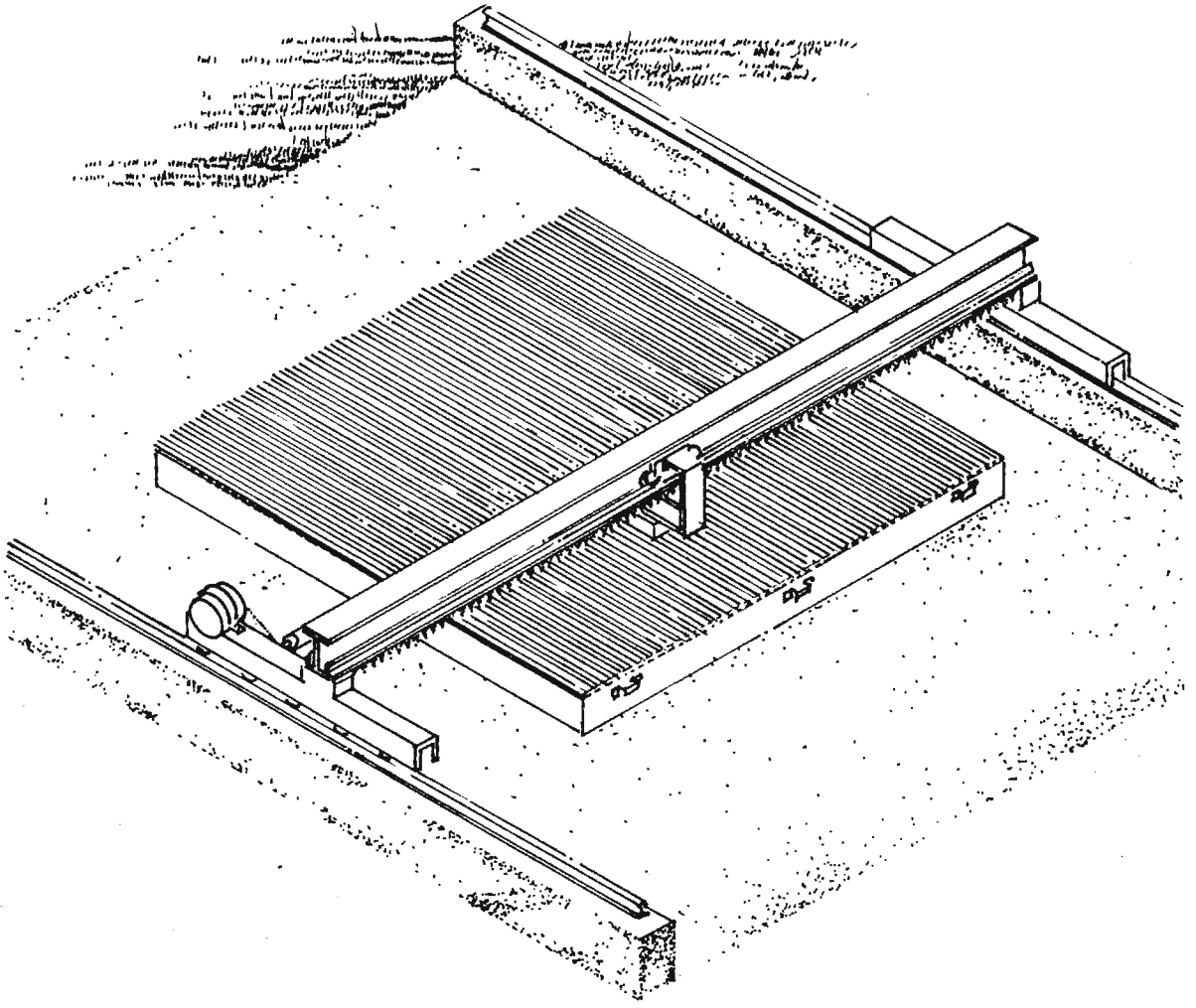

Figure 18. Planar Scanner Mechanism Concept for Subarray Near-Field Measurements

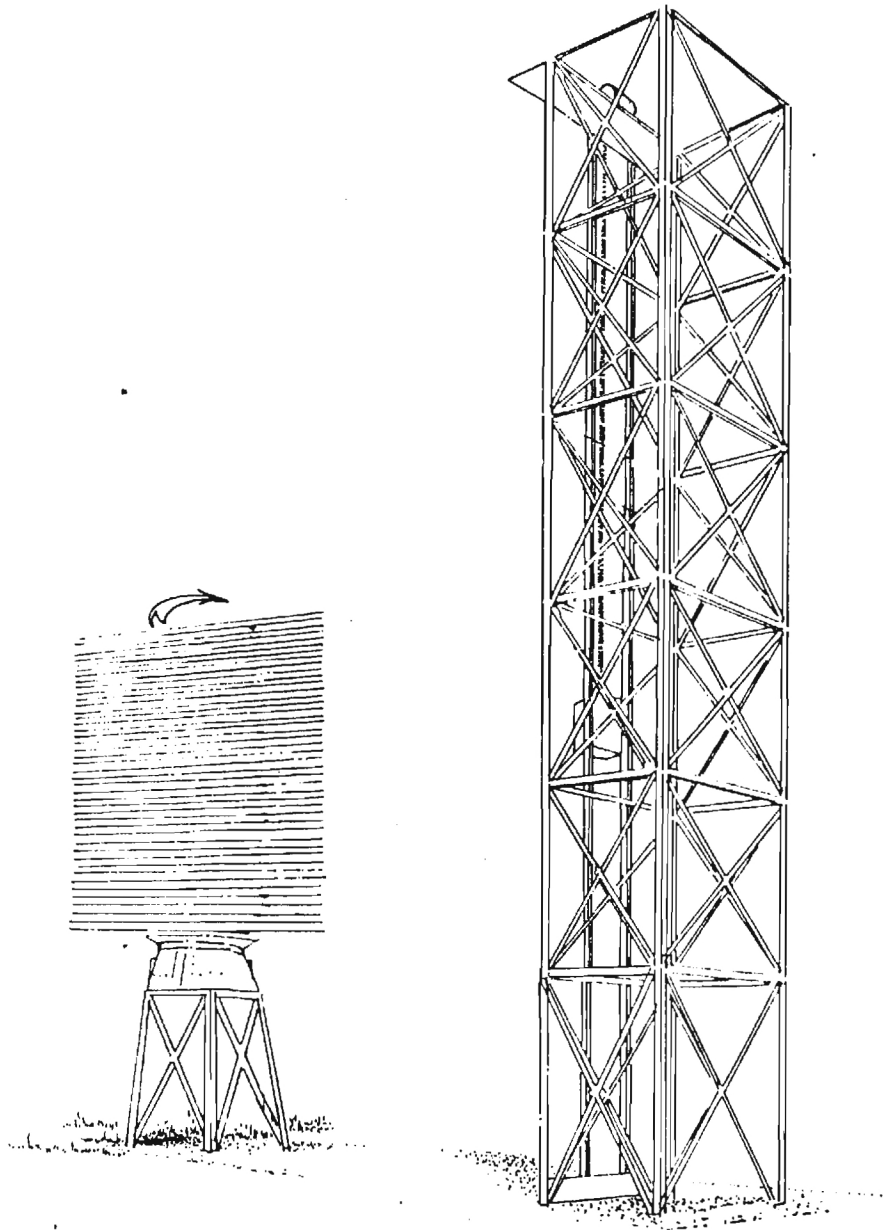

Figure 19. Cylindrical Scanner Concept for Subarray Near-Field Measurements

Tradeoff studies at Georgia Tech have suggested that the planar near-field concept has potential for array measurements of an SPS mechanical module (30 square meters). A large scanner concept applicable to mechanical module testing is shown in Figure 20. Problem areas to be resolved include computer requirements and the complexity of scanning over a much larger surface with acceptable precision. It may be possible to scan over a smaller area of the array - such as a quadrant with one positioner and then move either the scanner or the array.

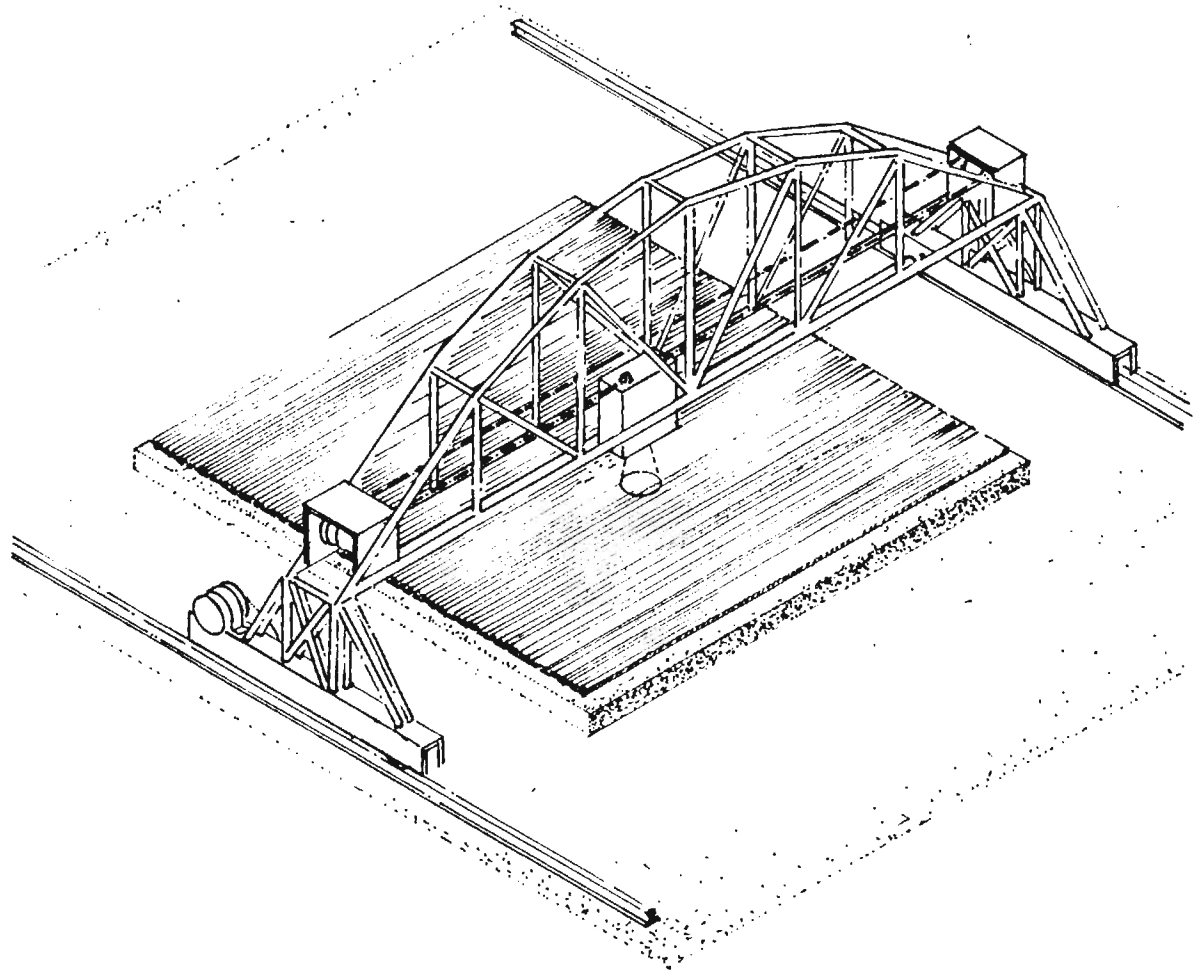

Figure 20. Planar Scanner Mechanism Concept for Mechanical Module Near-Field Measurements

7.0 COST TRADEOFFS

7.1 Far-Field Facility Concept and Cost Estimate

To assess the relative cost between far-field and near-field facility concepts, the far-field mountain top to mountain top facility illustrated in Figure 21 was studied. A detail cost breakdown appears in Appendix C. The receive and transmit site facilities are shown in Figures 22 and 23, respectively. The mechanical design of the SPS subarray support tower was based on handling maximum windloading in the order of 80 mph. Utilizing the microwave electronics system depicted prior in Figure 16, the total cost estimate for the far-field facility is summarized in Table 9.

7.2 Near-Field Facility Concept and Cost Estimate

Previous studies at Georgia Tech have considered the cost tradeoffs of far-field measurements versus a near-field measurement [8,11]. The results of these investigations for both large phased array and large reflector antennas demonstrate that costs are less for the near-field facility, and that the projected measurement accuracy is superior to that which could be obtained on a high quality far-field antenna measurement range.

However, the capital investment and operating costs of the near-field facility are functions of the required measurement accuracy. For example, if the on-axis antenna gain is to be determined to within 0.01 dB, the measurement probe axial position accuracy must be within 0.01 wavelength, i.e., 0.048 inches for the SPS. Also, the scan width-to-diameter ratio must be at least 1.5. Thus, this requirement has a direct effect on the mechanical design of the near-field measurement system.

Based on the linear planar scanner mechanism shown prior in Figure 18, The near-field measurements facility depicted in Figure 24 was conceived. This system presumes ceiling of measurement chamber covered with microwave absorber material, side walls are partially covered. The purpose of the antenna handling mechanism is for array set-up and handling. The system further presumes full high power testing will be employed.

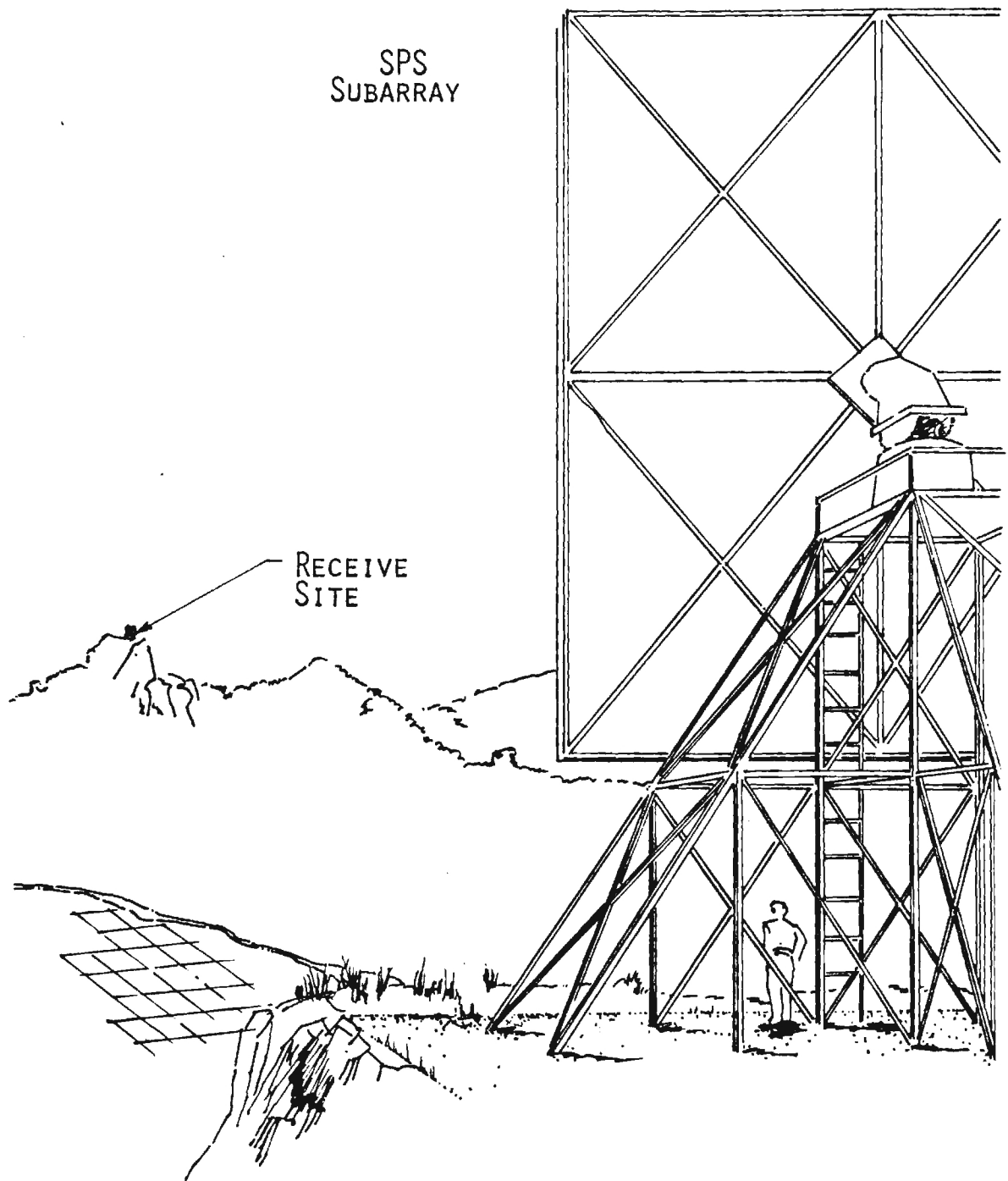

Figure 21. Mountain Top to Mountain Top Far-Field Facility Concept
(600 ft. height, 6-9 mile range)

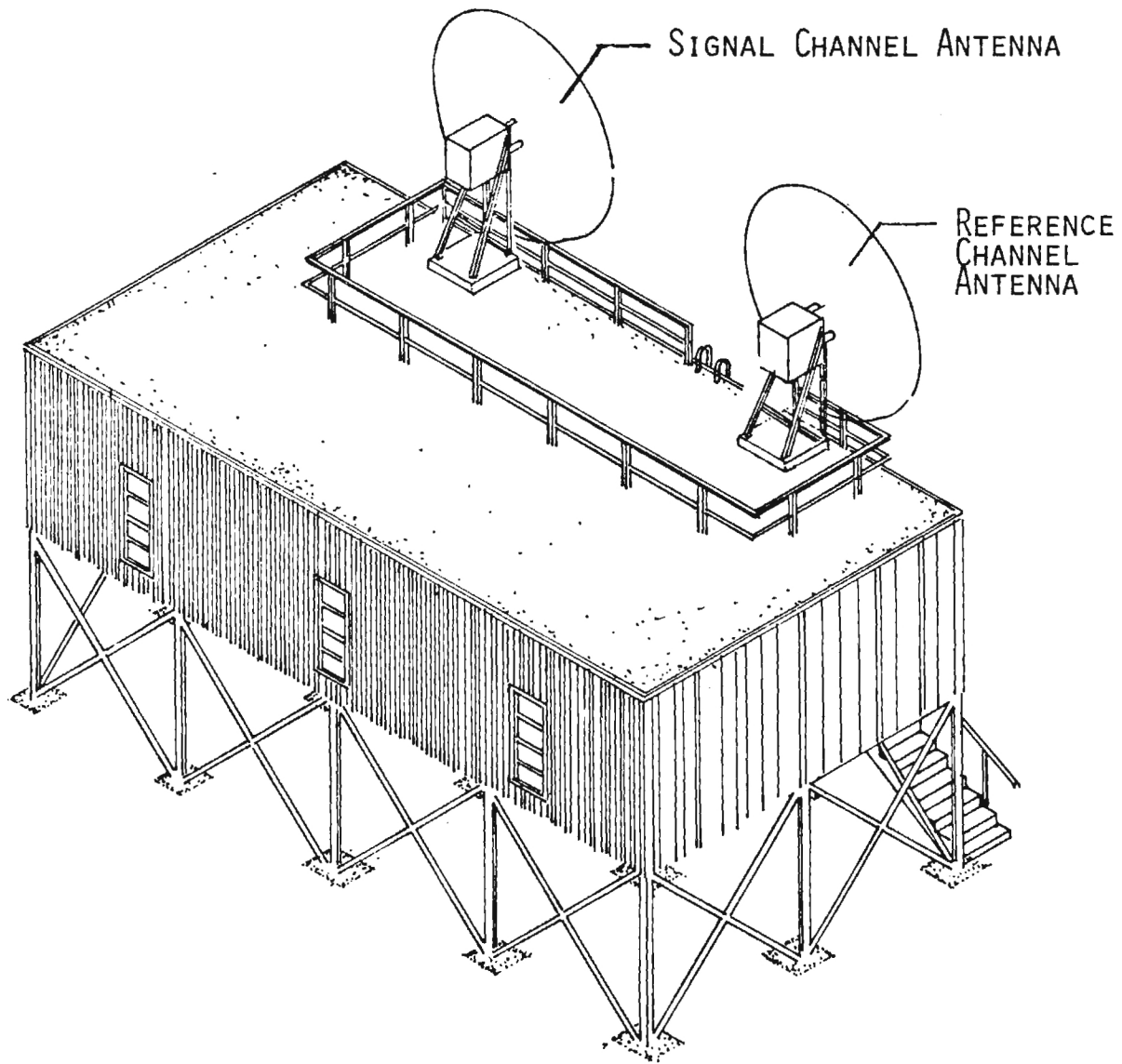

Figure 22. Receive Site Detail for Far-Field Facility Concept

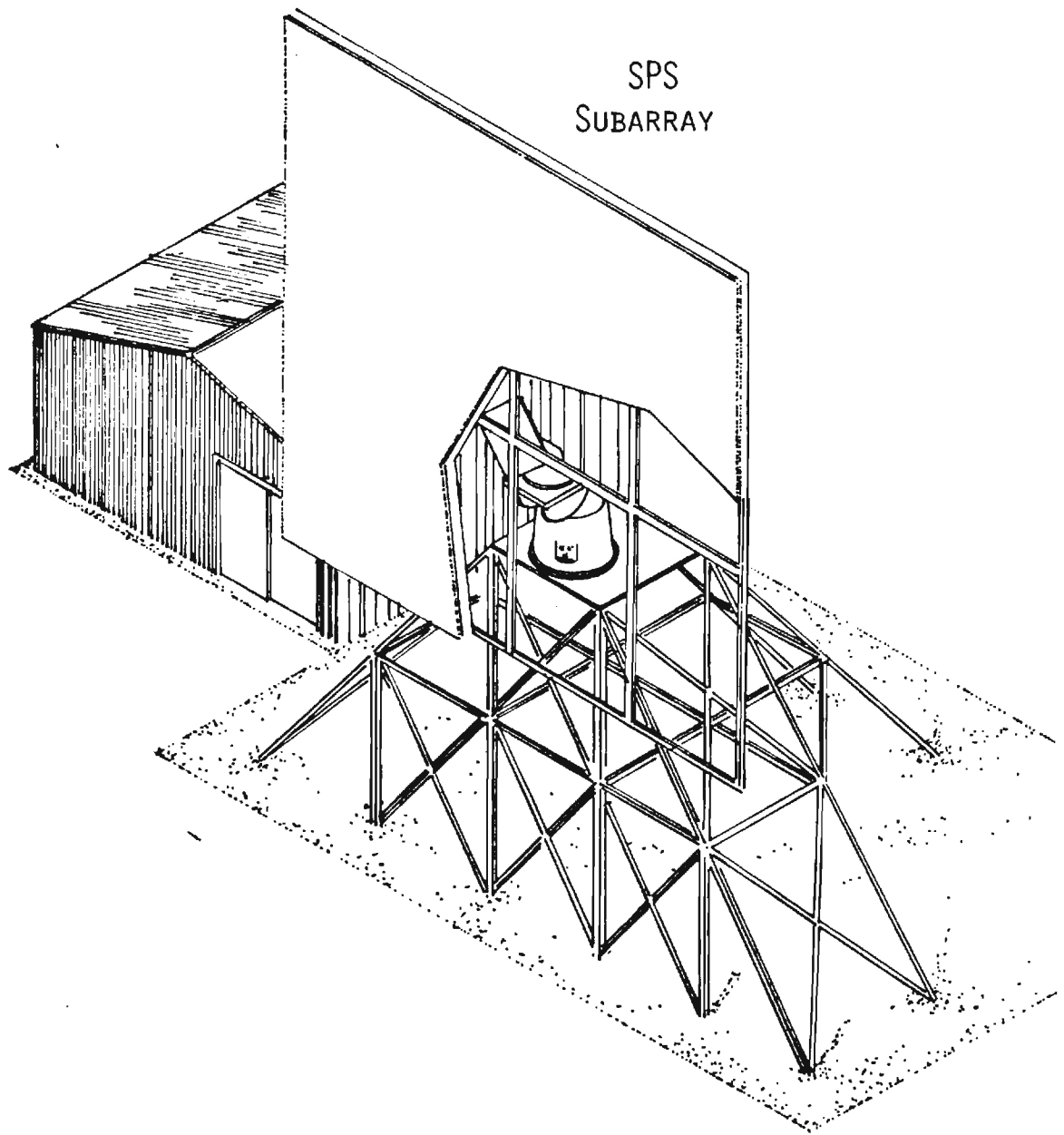

Figure 23. Transmit Site Detail for Far-Field Facility Concept

Table 9. Cost Summary for Far-Field Facility

RECEIVE/INSTRUMENTATION ELECTRONICS.....	359.8K
TRANSMIT SITE BUILDING.....	24.0K
TOWER FOR SPS SUBARRAY.....	120.0K
RECEIVE SITE BUILDING.....	107.8K
PRECISION ANTENNA POSITIONER.....	484.0K
	<hr/>
TOTAL	\$1,095.6K

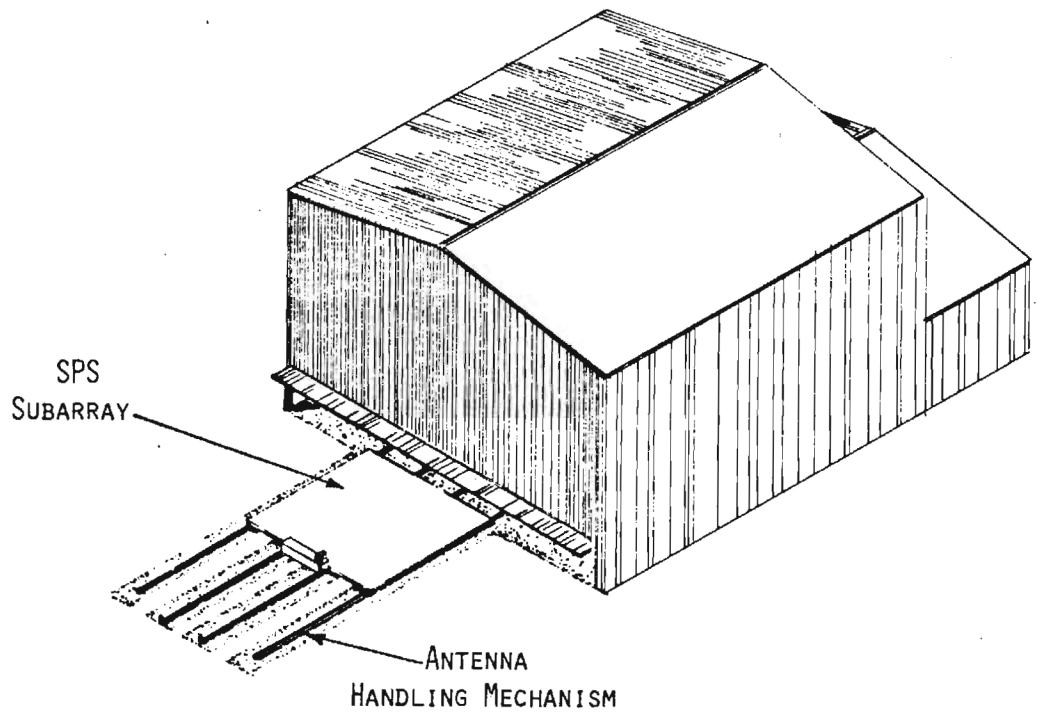

Figure 24. Planar Near-Field Measurement Facility Concept

Utilizing key elements of the microwave electronics depicted prior in Figure 16, an appropriate microcomputer, and based on the facility concept depicted in Figure 24, a cost estimate of the near-field concept is shown in Table 10. This data indicates projected costs for a near-field facility to be only 5-percent greater than the far-field measurements facility concept.

Table 10. Cost Summary for Near-Field Facility

RECEIVE/INSTRUMENTATION ELECTRONICS.....	254.2K
STEEL BUILDING.....	378.0K
MICROWAVE ABSORBER MATERIAL.....	156.0K
ANTENNA HANDLING MECHANISM.....	92.0K
LINEAR X-Y SCANNER.....	260.0K
	<hr/>
TOTAL	\$1,140.2K

8.0 CONCLUSIONS

To measure SPS antenna subarray beam power to within 1%, it was found that elevated ranges can meet all known requirements. Many potential sites having ranges greater than the required 3-mile minimum are available.

Because of the large electrical size of the SPS subarray panels and the requirement for high accuracy measurements, specialized facilities are required. Most critical measurement error sources have been identified for both conventional far-field and near-field techniques. Although the adopted error budget requires advances in state-of-the-art of microwave instrumentation, the requirements appear feasible based on extrapolation from today's technology.

Key development items identified include an adequate reference antenna gain standard, a stable precision amplitude (oscillator) standard, and a computer compensated and calibrated phase locked microwave receiver.

The possibility of utilizing near-field measurement techniques was studied. With adequate probe calibration and precision mechanical scanning, full 30 by 30 meter mechanical module antenna measurements may be performed. The performance and relative cost considerations between planar near-field and conventional far-field methods indicated the overall cost to be roughly the same.

9.0 REFERENCES

- [1] "Satellite Power System Concept Development and Evaluation Program Reference System Report," U.S. Department of Energy Report DOE/ER-0023, Washington, D.C. 20545, October 1978.
- [2] "Ground Plane Antenna Range Performance Measured and Calculated," J.H. Zickgraf, 1974 IEEE/AP-S Symposium, Georgia Tech, June 1974.
- [3] "Accuracy Considerations in the Measurement of the Power Gain of a Large Microwave Antenna," M. Kanda, 1974 IEEE/AP-S Symposium, Georgia Tech, Atlanta, June 1974.
- [4] "Accurate Measurement of Antenna Gain and Polarization at Reduced Distances by an Extrapolation Technique," A.C. Newell, R.C. Baird and P.F. Wacker, IEEE Transactions on Antennas and Propagation, July 1973.
- [5] "Gain Calibration of a Horn Antenna Using Pattern Integration," A. Ludwig, J. Hardy and R. Norman, Technical Report 32-1572, Jet Propulsion Laboratory, Pasadena, California, October 1972.
- [6] "A Radiometric Antenna Gain Calibration Method," B.L. Ulich, IEEE Transactions on Antenna and Propagation, March 1977.
- [7] "Upper-Bound Errors in Far-Field Antenna Parameters Determined from Planar Near-Field Measurements: Part 1 - Analysis," A.D. Kaghjian, NBS Technical Note 667, October 1975.
- [8] "Correction of Near-Field Antenna Measurements Made with an Arbitrary But Known Measuring Antenna," D.M. Kerns, Electronics Letters, Vol. 6, May 1970.
- [9] "Plane Wave Scattering Matrix Theory of Antenna and Antenna-Antenna Interaction: Formulation and Application," D.M. Kerns, Journal of Research of the Nation Bureau of Standards, Vol. 80B, No. 1, January 1976.
- [10] "Probe Compensated Near-Field Measurements Basic Theory, Numerical Techniques, Accuracy," W.M. Leach, Jr., E.B. Joy and D.T. Paris, IEEE/AP-S Symposium, Georgia Tech, June 1974.
- [11] "Automated Near-Field Measurements to Obtain Far-Field Patterns of Aperture Antennas and Phased Arrays," H.A. Ecker, et al, IEEE/AP-S Symposium, Georgia Tech, June 1974.
- [12] "Near-Field Pattern Measurement Facility," C.E. Kirchoff, 1979 Antenna Applications Symposium, U. of Illinois, September 1979.
- [13] "Implementing a Near-Field Antenna Test Facility," W.A. Harmening, Microwave Journal, Vol. 22, No. 9, September 1979.

- [14] "Automated Near-Field Test Set for Phased Array Production," D. Staiman, 1979 Antenna Applications Symposium, U. of Illinois, September 1979.
- [15] "A Study of the Application of Near-Field Measurements for NASA Requirements," B.J. Cown, C.E. Ryan, Jr., A.L. Bridges and J.D. Adams, Final Engineering Report, Contract NAS5-2234, Georgia Institute of Technology, March 1976.
- [16] "An Investigation of the Accuracy of Far-Field Radiation Patterns Determined from Near-Field Measurements," G.P. Rodrigue, E.B. Joy and C.P. Burns, Final Report on Georgia Tech Project E-21-621, for U.S. Army Missile Command, Redstone Arsenal, Alabama, August 1973.
- [17] "Considerations for High Accuracy Radiation Efficiency Measurements for the Solar Power Satellite Subarrays," D.J. Kozakoff, J.M. Schuchardt and C.E. Ryan, Proceedings of the Solar Power Satellite Workshop on Microwave Power Transmission and Reception, N.A.S.A. Johnson Space Center, Houston, Texas 77058, January 1980.

Appendix A. Computed Fresnel Reflection Coefficient for Ground Reflection
Range

Appendix A. Computed Fresnel Reflection Coefficient for Ground Reflection Range

Using the nominal permittivity and conductivity values for moist soil, and the formulas for Fresnel Reflection Coefficients appearing in Zickgraf [2], the following results are obtained

$$\epsilon_0 = 9.954 \times 10^{-12} \text{ f/m}$$

$$\epsilon = 44.27 \times 10^{-12} \text{ f/m}$$

$$\sigma = 0.1 \text{ mhos/m}$$

The total ground permittivity may be expressed in the form

$$\epsilon_r = \epsilon_r' - j\epsilon_r''$$

where

$$\epsilon_r' = \frac{44.27 \times 10^{-12}}{8.854 \times 10^{-12}} = 5.0$$

At the SPS operating frequency:

$$\epsilon_r'' = \frac{\sigma}{\omega} = 6.496 \times 10^{-12} \text{ f/m}$$

$$\epsilon_r'' = \frac{6.496 \times 10^{-12}}{8.854 \times 10^{-12}} = 0.734$$

or,

$$\epsilon_r = 5.0 - j 0.734.$$

Using this value for complex permittivity of moist soil, the Fresnel Reflection coefficients were computed values are shown in Table A-1 and are plotted in Figure A-1.

Table A-1
Surface Reflection Value

Grazing Angle (degrees)	Fresnel Reflection (Vertical Polarization)	Coefficient (Horizontal Polarization)
0	1.00	1.00
1	0.94	0.99
2	0.88	0.98
5	0.73	0.95
10	0.54	0.90
15	0.41	0.85
20	0.35	0.81

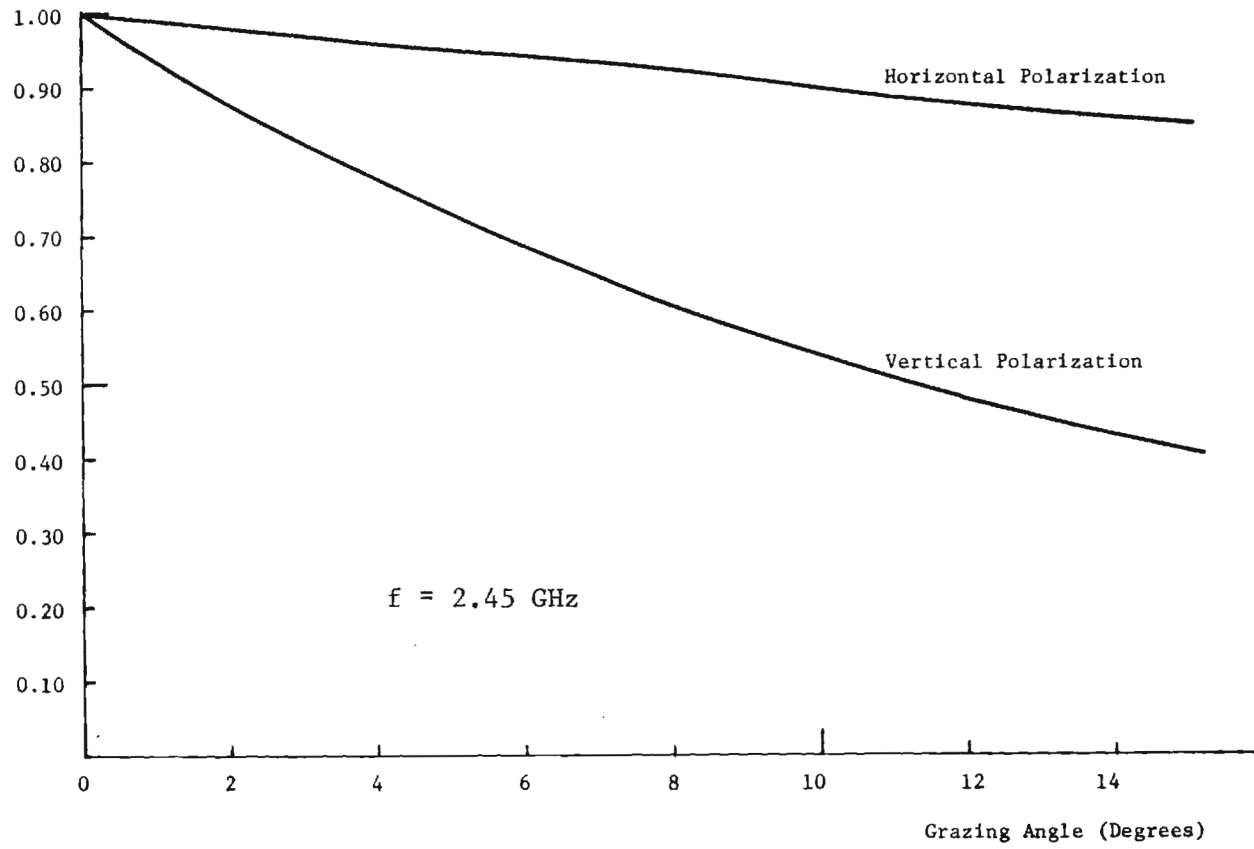

Figure A-1. Fresnel Reflection Coefficients for Moist Soil ($\epsilon_r = 5$, $\sigma = 0.1$ mhos/meter)

Appendix B. Ground Reflection Range Vertical Field Intensity
Distribution at Receive Site

Some general trends in field non-uniformity were studied by an analysis of vertical field intensity at the receive site of a ground reflection range. Figures B-1 through B-3 investigate the effect of absorber barricades at the midpoint of a 0.5-mile ground reflection range; the transmit antenna HPBW was taken as 3.5-degrees. A -30 dB absorber barricade is pushing the state-of-the-art.

The effect of transmit antenna HPBW was studied in the data of Figures B-4 through B-6 for the half-mile range. Figures B-7 and B-8 plot the vertical field intensity for a 0.5-mile range for transmit antenna heights of 45 and 90-feet, respectively; transmit antenna HPBW is 2.3-degrees. Figure B-9 is similar data but for a transmit antenna HPBW of 3.5 degrees.

For a transmit antenna HPBW of 3.5-degrees, Figures B-10 and B-11 plot the vertical field intensity at ranges of 1 and 2 miles, respectively.

Figure B-12 examines a 4-mile range where an absorber barricade of -30 dB is employed. This particular case may be credible for SPS subarray measurements.

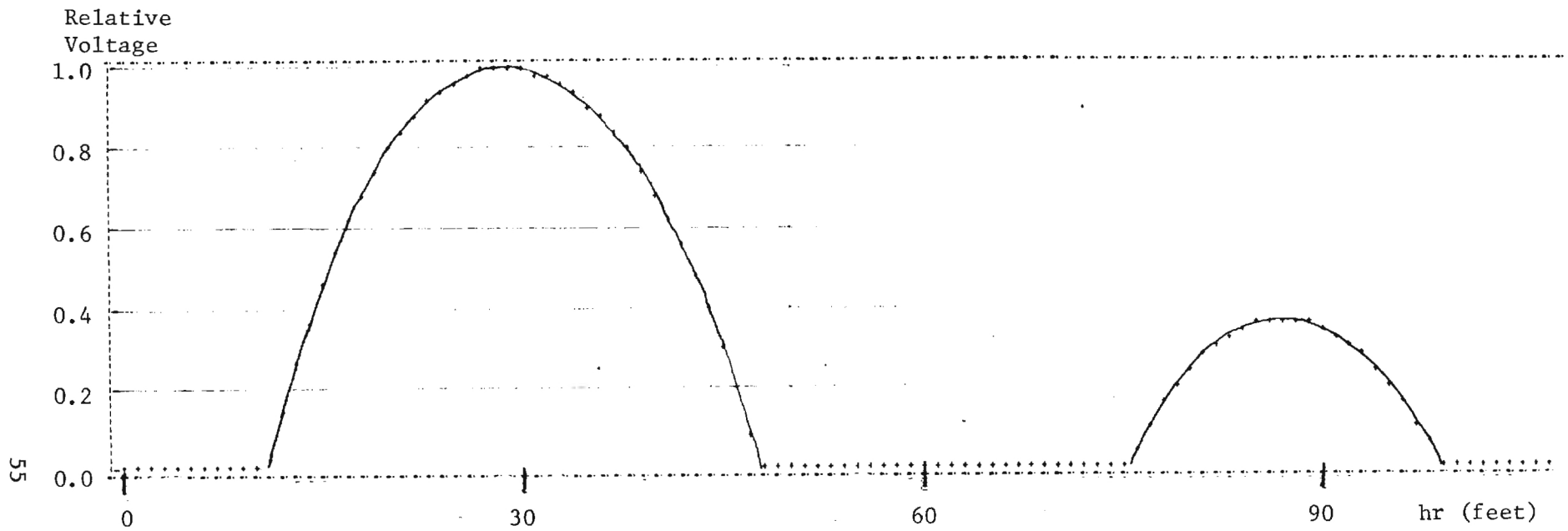

Figure B-1

Vertical Field Intensity for 0.5-mile Range for $h_t = 8.83$ -feet, HPBW = 3.5-degrees;
No Absorber Barricade

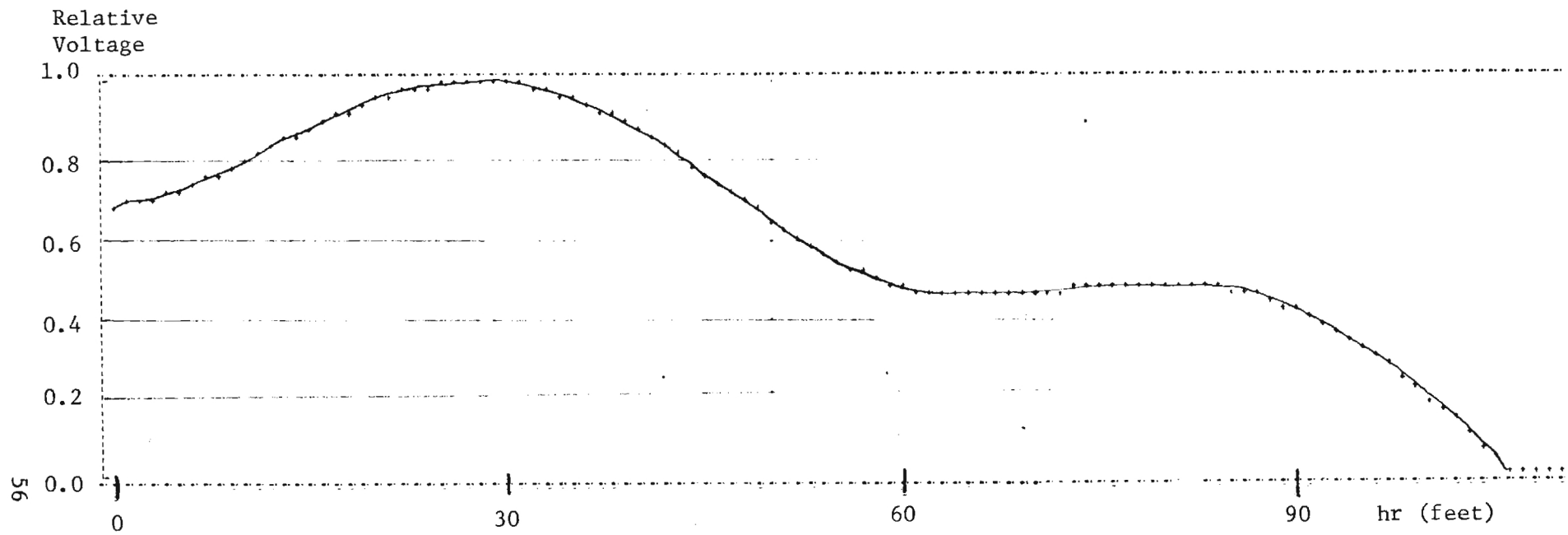

Figure B-2

Vertical Field Intensity for 0.5-mile Range for $h_t = 8.83$ feet, HPBW = 3.5-degrees;
 -20 dB Absorber Barricade

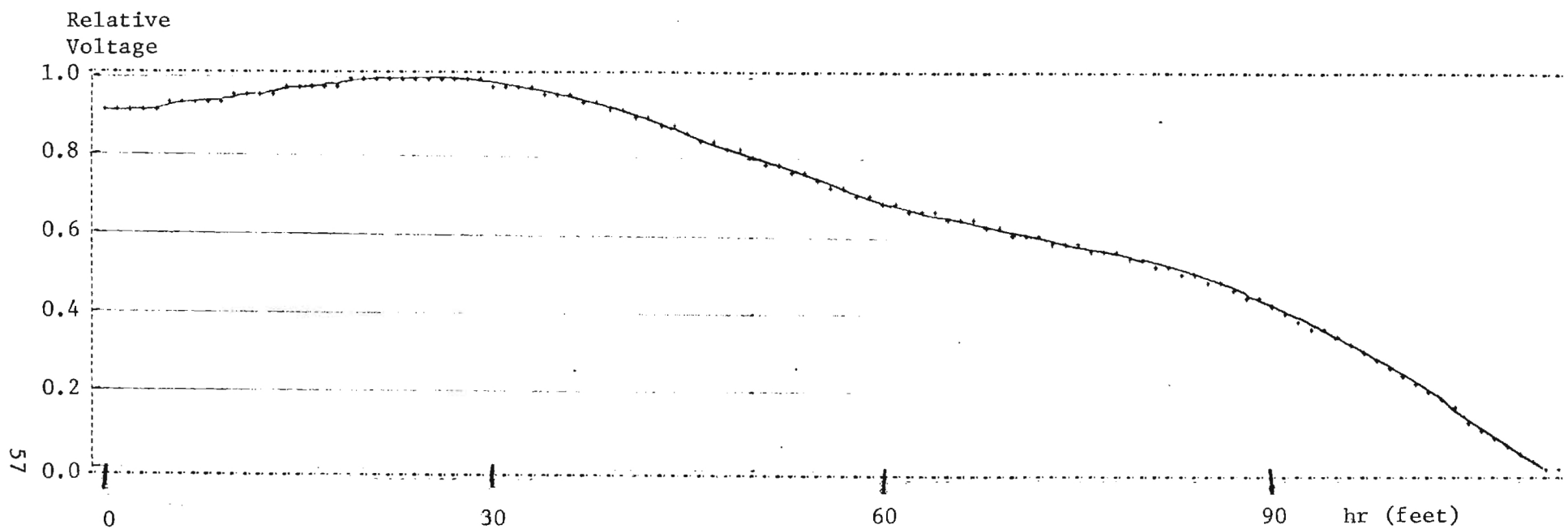

Figure B-3

Vertical Field Intensity for 0.5-mile Range for $h_t = 8.83$ feet, HPBW = 3.5-degrees;
-30 dB Absorber Barricade

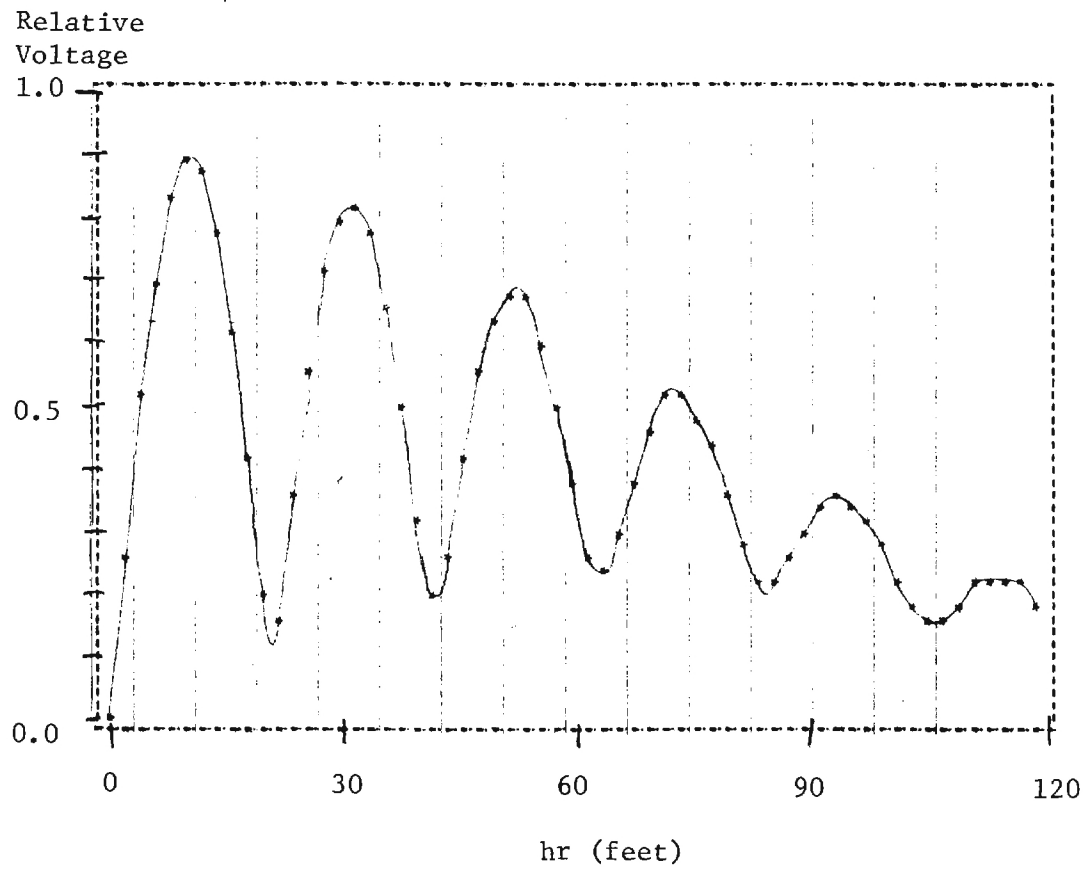

Figure B-4

Vertical Field Intensity for 0.5-mile Range for $h_t = 25$ -feet, NPBW = 2.3 degrees

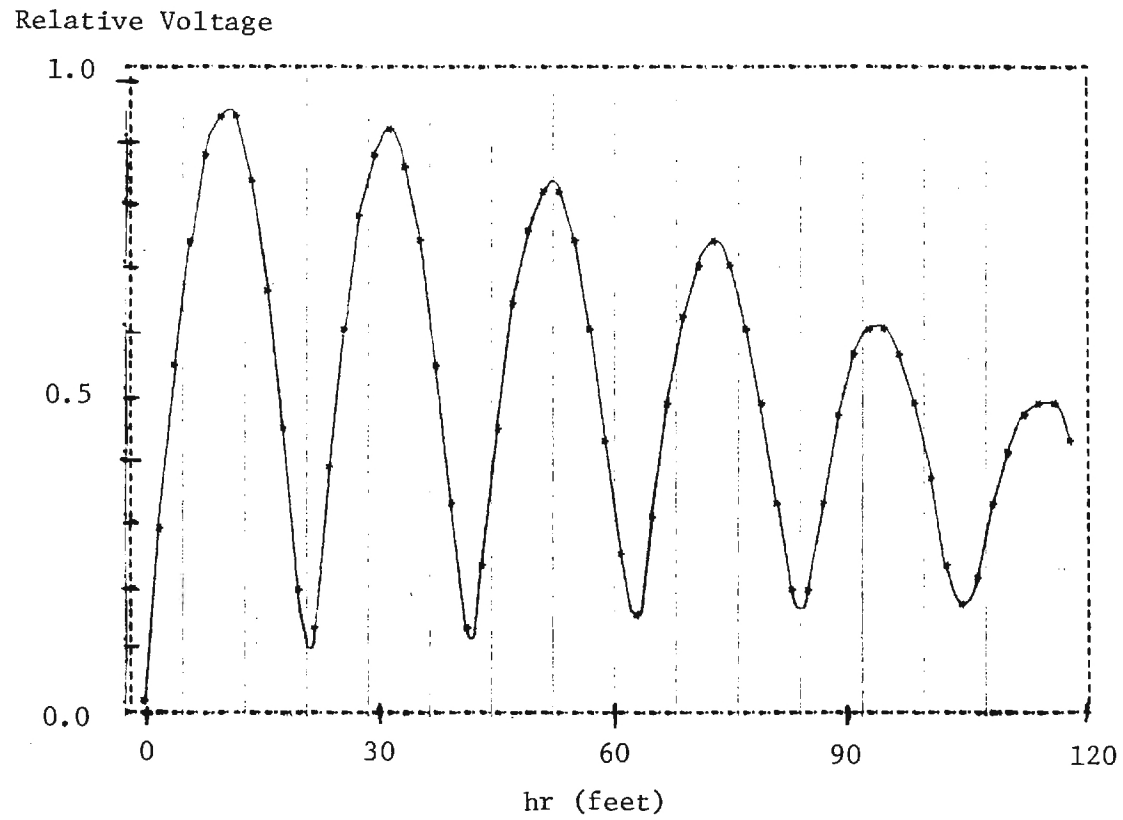

Figure B-5

Vertical Field Intensity for 0.5-mile Range for $h_t = 25$ feet, HPBW - 3.5-degrees

Relative Voltage

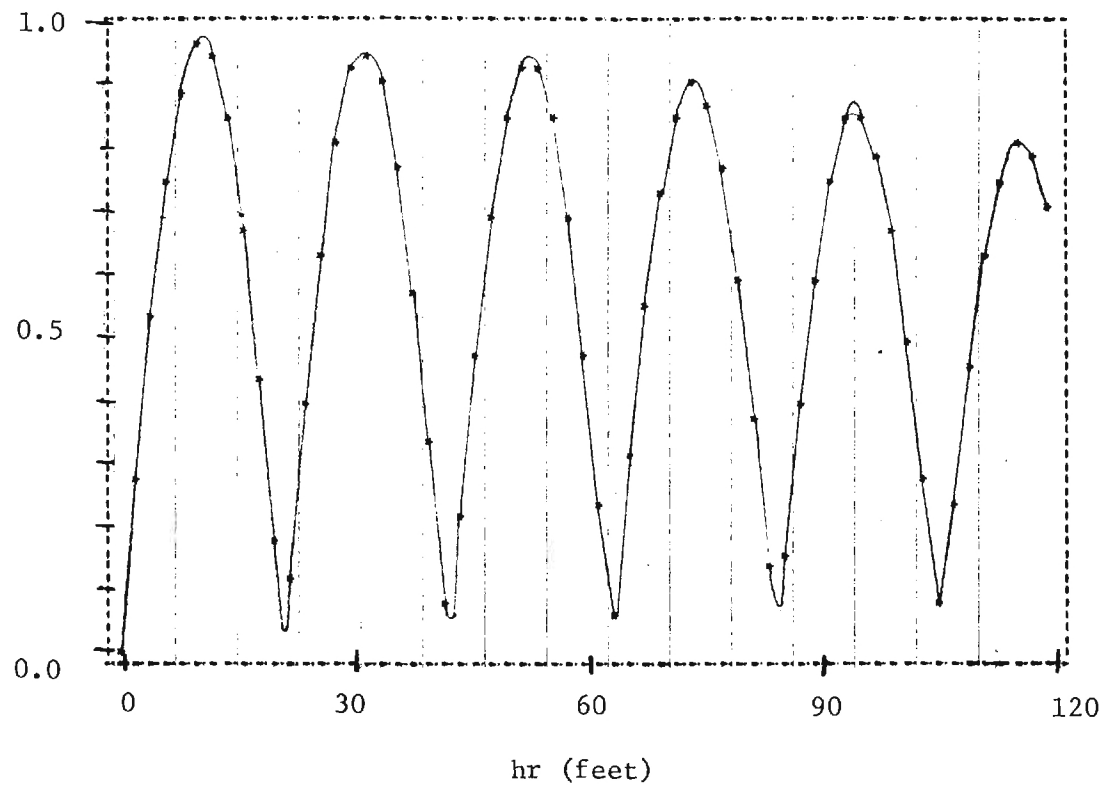

Figure B-6

Vertical Field Intensity for 0.5-mile Range for $h_t = 25$ feet, HPBW = 7.0-degrees

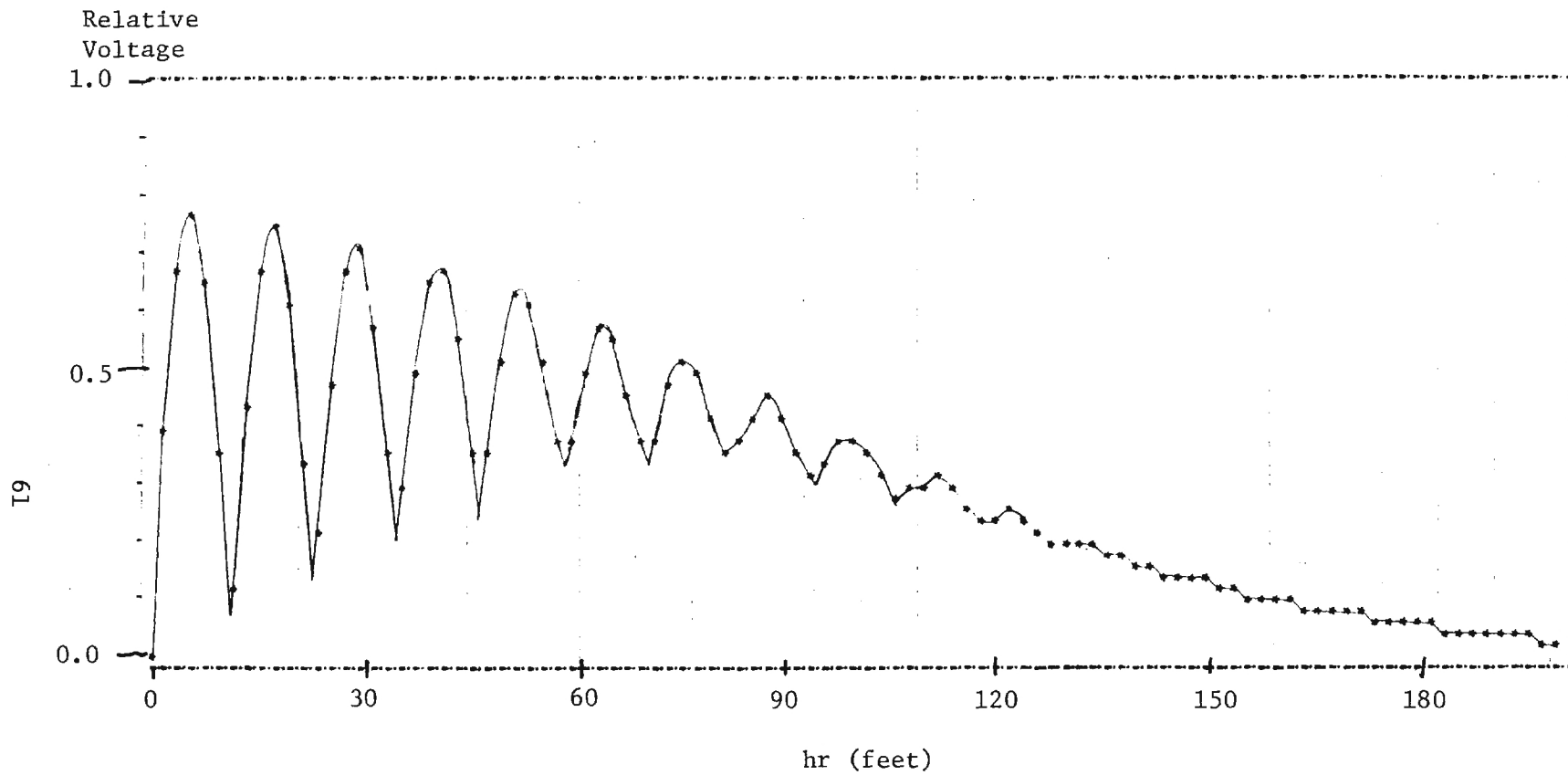

Figure B-7

Vertical Field Intensity for 0.5-mile Range for $h_t = 45$ feet, HPBW = 2.3-degrees

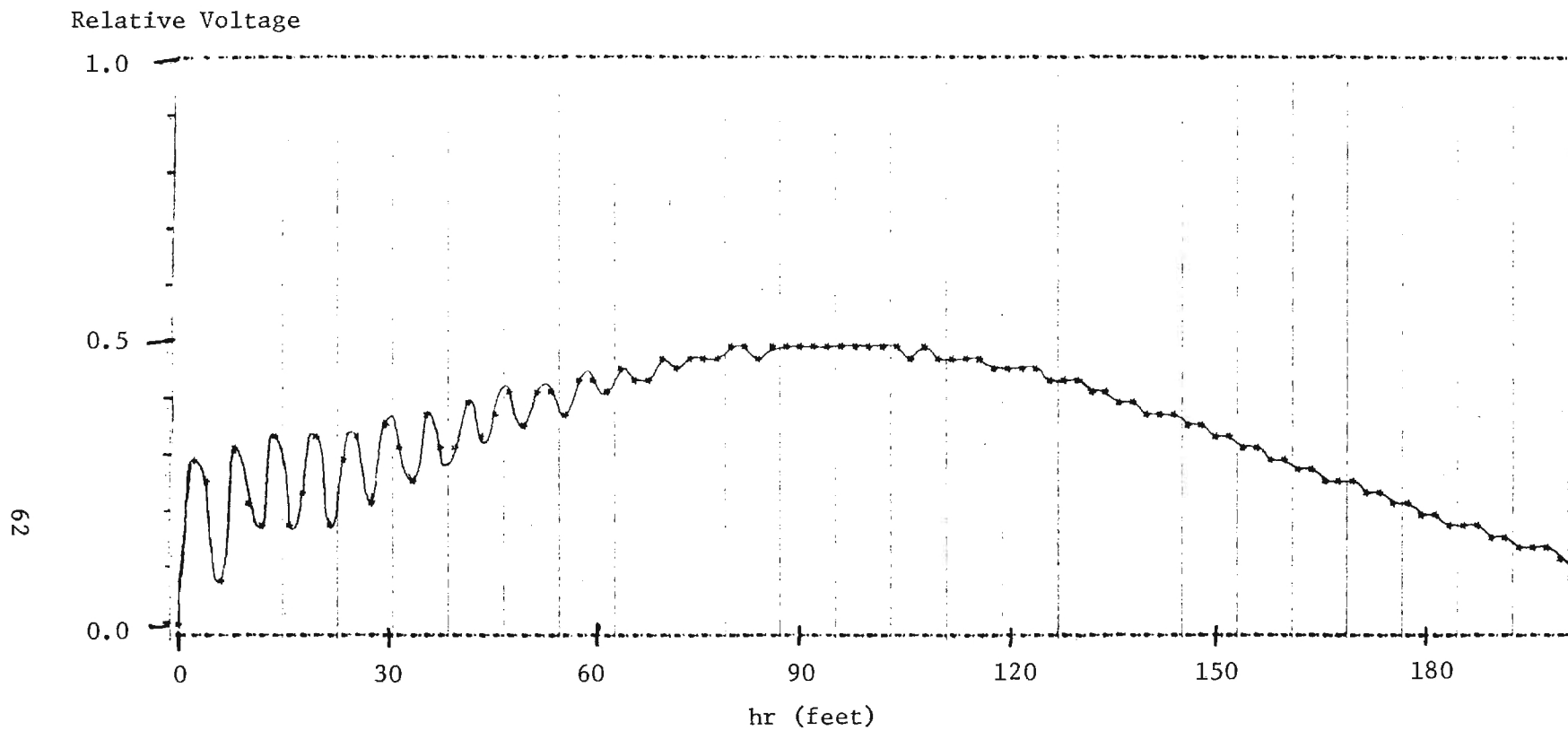

Figure B-8

Vertical Field Intensity for 0.5-mile Range for $h_t = 95$ feet, HPBW = 2.3-degrees

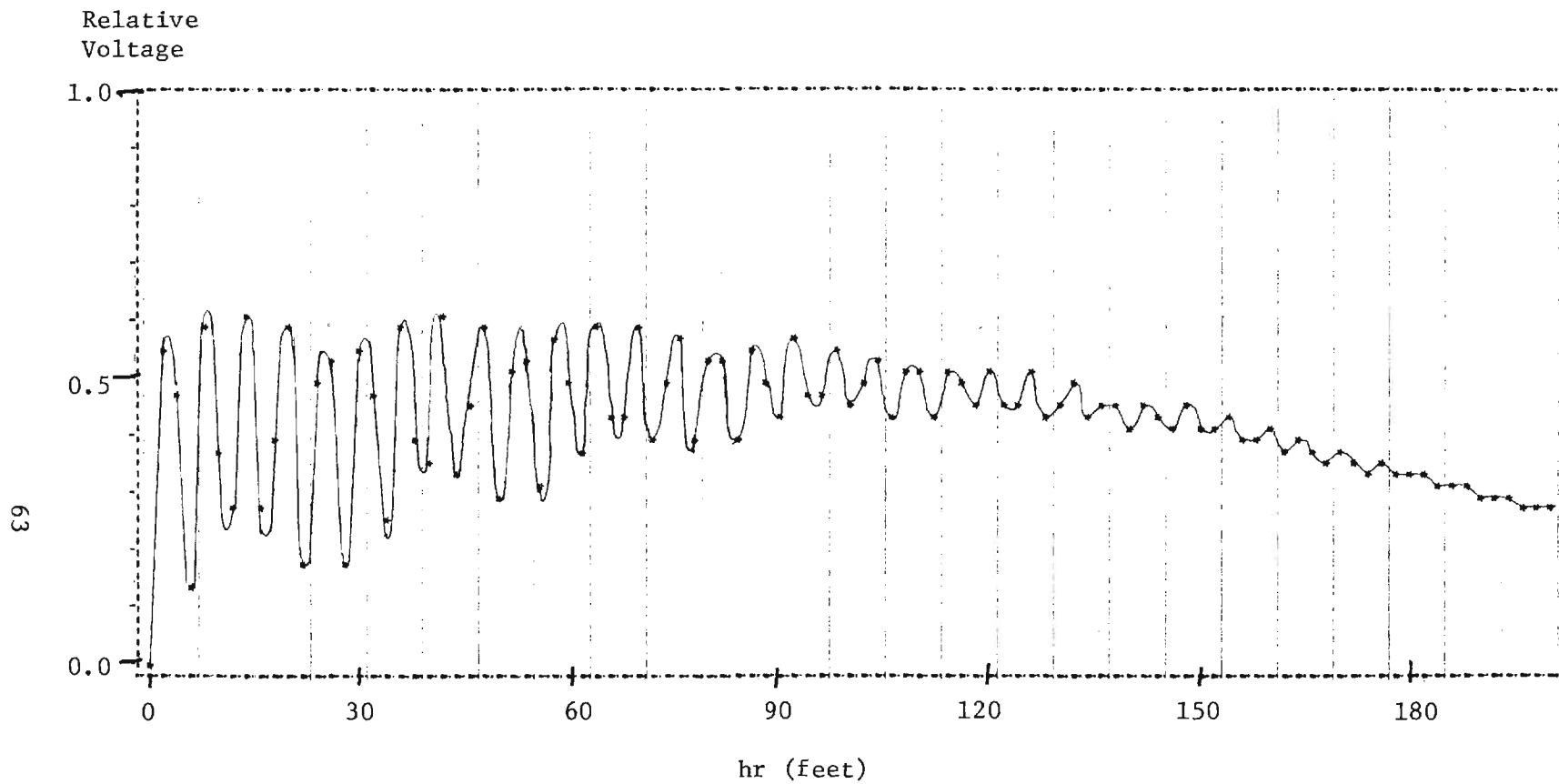

Figure B-9

Vertical Field Intensity for 0.5-mile Range for $h_t = 95$ feet, HPBW = 3.5-degrees

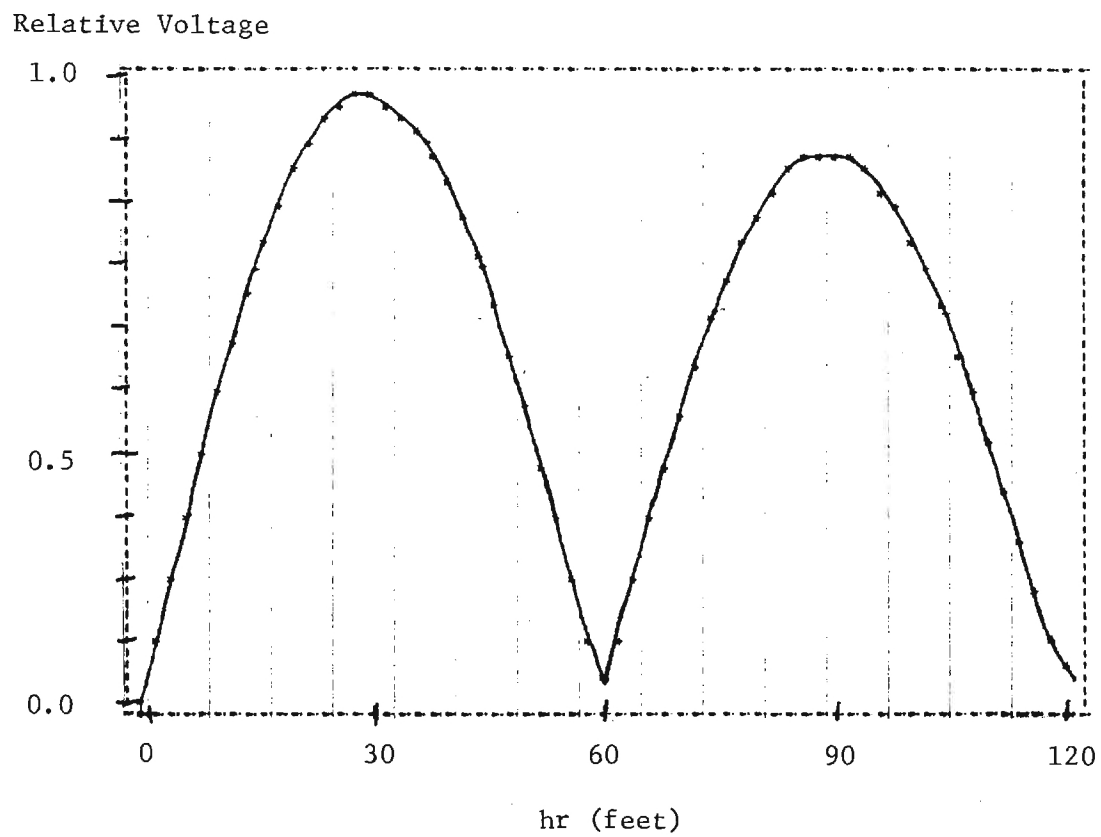

Figure B-10

Vertical Field Intensity for 1-mile Range for $h_t = 17.7$ feet, HPBW = 3.5-degrees

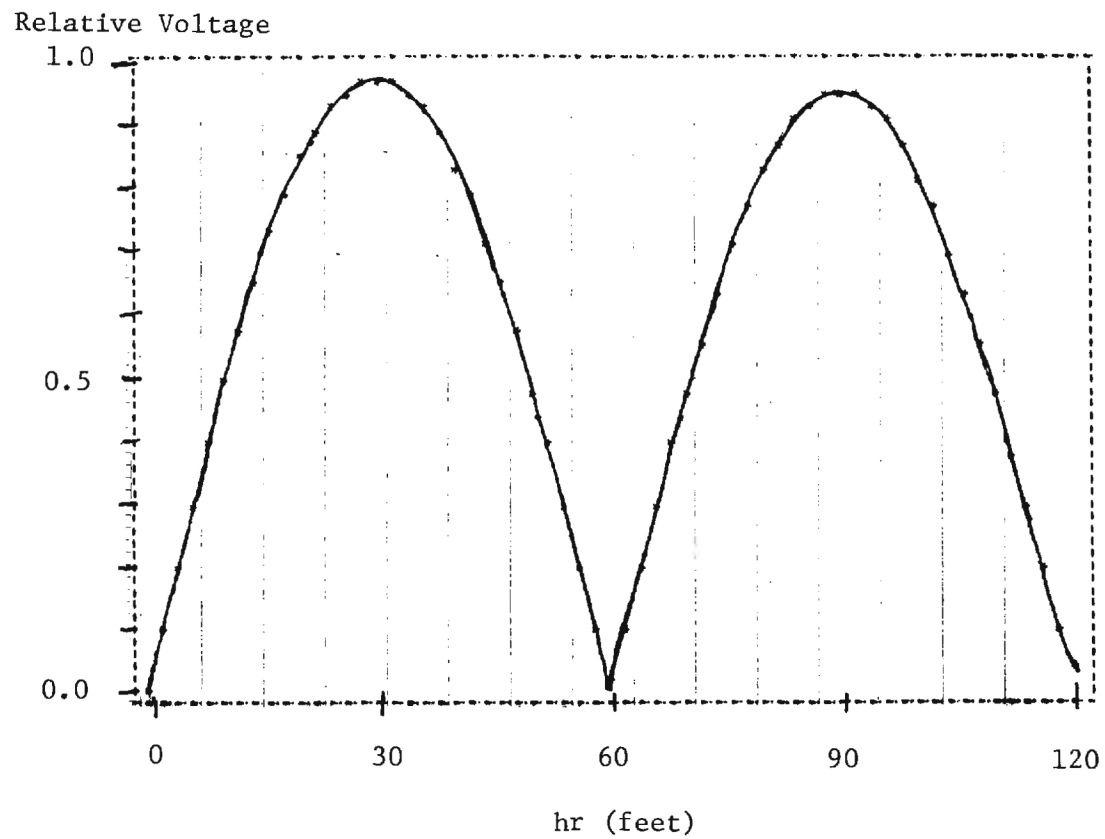

Figure B-11

Vertical Field Intensity for 2-mile Range for $h_t = 35.35$ feet, HPBW = 3.5-degrees

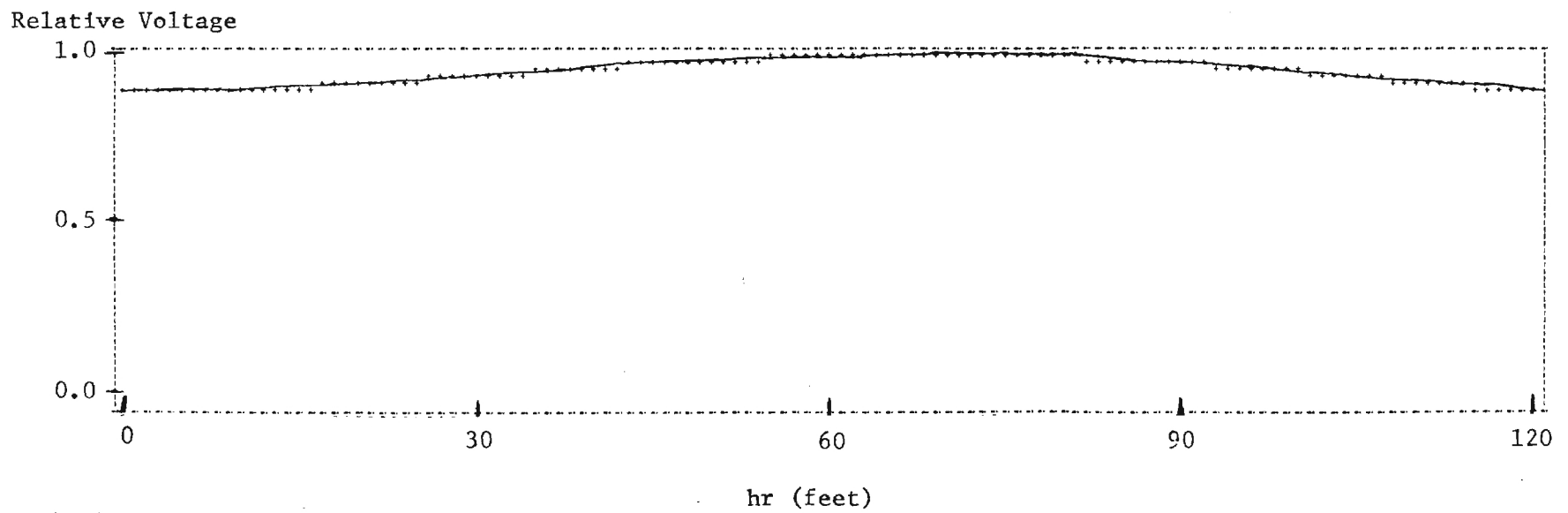

Figure B-12

Vertical Field Intensity for 4-mile Range for $h_t = 30$ feet, HPBW = 2.3-degrees;
-30 dB Absorber Barricade

Appendix C. Facility Cost Estimate Breakdown Detail

The purpose of this appendix is to provide greater detail in the cost tradeoffs between the candidate antenna measurements facilities. Figure C-1 is a summary of hardware and cost requirements for the far-field facility concept. Figure C-2 is similar data for the proposed near-field facility.

Figure C-1

SUMMARY OF HARDWARE AND COST REQUIREMENTS
FOR FAR-FIELD FACILITY CONCEPT

RECEIVE/TRANSMIT ELECTRONICS		\$359.8K
S/A 1774 3-channel receiver	\$42K	
special receiver mods	10K	
S/A 1871A digital freq. display	11.1K	
S/A 1832 digital amp. display		
(two @ 4.2K ea.)	8.4K	
Andrew 12 ft. dish antennas		
(two @ 5.3K ea.)	10.6K	
Stable RF amplitude ref. unit	50K	
Receive ref. module	28K	
Ultra-precision RF atten.	50K	
Connectors, waveguide, coax.	5K	
Equip. rack, hardware	5K	
Transmit ref. module	27.5K	
HP 1000/45 computer	46.5K	
HP 9862 plotter	3.2K	
HP 9881A line printer	8K	
UHF ref. system:		
140 tel. poles @ \$100	14K	
Coax line (7-miles)	18.5K	
CATV line amps	10K	
4 mm labor for installation		
@ 3K/mm)	12K	
TRANSMIT SITE EQUIPMENT BUILDING		\$24.0K
400 sq. ft. @ \$60/sq. ft. (on 4-inch slab,		
insulated, heat and air cond., AC pwr., etc.)		
TOWER FOR SPS ANTENNA		\$120.0K
Structural materials (20 ft.		
high, 36.2 klb structure)	\$17K	
Deck, rail, stairs	3K	
Concrete foundation	22K	
Labor:		
Engineer (1 mm @ \$5K)	5K	
Draftsman (3 mm @ 3K)	9 K	
Riveter/welder/machinist		
(16 mm @ 4K)	64K	

RECEIVE SITE BUILDING \$107.8K

Foundation & 10 ft. tall base to raise bldg. to 20 ft.	\$40K
1000 sq. ft. bldg. at \$60/sq. ft. (insulated, heated, air cond., AC power, plumbing, etc.)	60K
Two antenna mounts (700 lb. steel)	1.3K
Labor:	
Engineer (0.5 mm @ 5K)	2.5K
Machinist (1 mm @ 4K)	4.0K

SPS PRECISION ANTENNA POSITIONER SYSTEM \$484K

S/A model with SMAP (19 bit encoder readouts)	\$440K
S/A 1843 digital dual synchro displays (two @ 7.4K) BCD out	14.8K
S/A 4116A remote control unit	2.4K
S/A 4168A position control unit (two @ 13.4K)	26.8K

TOTAL \$1,095.6K

Figure C-2

SUMMARY OF HARDWARE AND COST REQUIREMENTS
FOR PLANAR NEAR-FIELD FACILITY CONCEPT

RECEIVE/TRANSMIT ELECTRONICS		\$254.2K
S/A 1774 3-channel receiver	\$42K	
special receiver mods	10K	
S/A 1871A digital freq. display	11.1K	
S/A 1832 digital ampl. display		
(two @ 5.3K ea.)	10.6K	
Stable RF amplitude ref. unit	50K	
ultra-precision RF atten.	50K	
Connectors, waveguide, coax	3K	
Equipment rack, hardware	4K	
Signal generator	4.5K	
Oscillator synchronizer	3K	
HP 1000/45 Computer	46.5K	
HP 9862 Plotter	3.2K	
HP 9881A line printer	8K	
Direc. compler & misc. parts	2K	
Horn probe antenna	0.5K	
Absorber to mask scanner	8K	
STEEL BUILDING		\$378K
Anechoic chamber portion on		
6-inch slab, insulated, heat		
& air cond., AC power, etc.		
(3600 sq. ft. @ \$90)	\$324K	
Work area portion		
(900 sq. ft. @ \$60/ft.)	54K	
MICROWAVE ABSORBER MATEIRAL		\$156K
Basic absorber, including instal-		
lation, -50 dB quiet zone at		
2.45 GHz	\$150K	
Shipping from Emerson Cumming		
to MSFC	6K	
ANTENNA HANDLING MECHANISM		\$92K
Concrete pad exterior to bldg.	\$11K	
Steel tracks (240 ft.)	2K	
Drive chassis	8K	
Servo motors, controlls,		
encoders, drive chain	16K	
Labor:		
Engineer (2 mm @ 5K)	10K	

Draftsman (3 mm @ 3K)	9K
Machinist (9 mm @ 4K)	36K

LINEAR X-Y SCANNER MECHANISM \$260K

(mechanical accuracy \pm 0.025 inches in transverse and longitudinal planes; scan region 45 ft. x 45 ft.)

Beam steel members	\$10K
Support frame	13K
Drive rollers	5K
Servo motors & gear drive	24K
Controller, encoders, A/D conv., readout devices	35K
Hardware & misc.	6K
Rails and bearings	9K
Labor:	
Engineer (12 mm @ 5K)	60K
Draftsman (6 mm @ 3K)	18K
Machinist (20 mm @ 4K)	80K

TOTAL	\$1,140.2K
-------	------------

Appendix D. Subarray Weight Estimate

Appendix D. Subarray Weight Estimate

SPS subarray weight was initially estimated based on standard WR 340 waveguide. Based on published wall thickness data, the data shown in Figure D-1 indicates 0.9795 pounds per linear foot of waveguide.

In Table D-1, an estimate of total weight is arrived at assuming the 10-meter square subarray is fabricated from approximately 110 lengths of the WR 340 waveguide. Added to the basic waveguide weight was an additional 40% to allow for structural support structure. The total weight estimate for the aluminum version was 2.5 tons.

From the data of Table D-1, it is noted that the projected weight of a mechanical module is 22.5 tons.

WR 340 (RG 112/u)
2.2 - 3.3 GHz

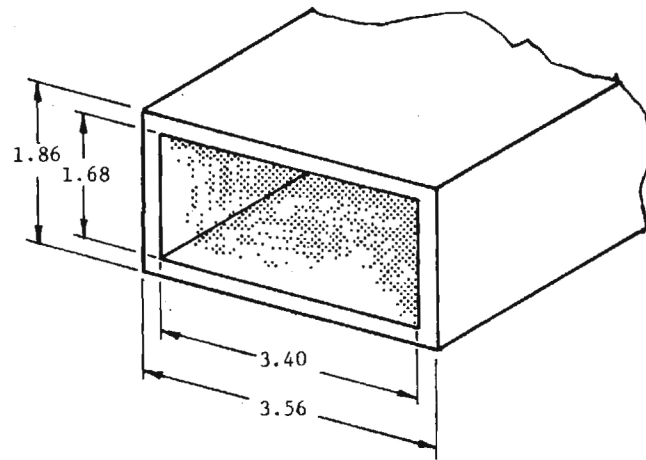

Material	Density lbs/in ³	Waveguide in ³ per ft	Waveguide lbs per ft
Copper	0.3180	10.915	3.1818
Aluminum	0.0979	10.915	0.9795

Figure D-1. Waveguide Weight Estimate

Table D-1. Estimates of Minimum Subarray Weight

Subarray Size (M)	Subarray Size (ft)	No. of WR340 Waveguides*	Total Length of WR340 (ft)	Total Aluminum Waveguide Wt. (tons)	Total Est. Aluminum Array Wt. (tons)	Total Copper Waveguide Wt. (tons)	Total Est. Copper Array Wt. (tons)
1	3.281	11.059	36.273	0.02	0.025	0.058	0.08
3	9.843	33.177	326.546	0.16	0.225	0.520	0.73
7	22.966	77.413	1,777.859	0.87	1.225	2.828	3.98
10	32.808	110.590	3,628.284	1.78	2.5	5.772	8.0
30	98.425	331.770	32,654.560	15.99	22.5	51.95	73.09
70	229.659	774.131	177,785.936	87.07	122.5	282.84	397.92
100	328.084	1,105.901	362,828.441	177.69	250	577.22	812.08

* Outer width = 3.56 inches = 0.2967 ft.

Appendix E. Vertical Field Intensity at Receive Site for Mountain
Top to Mountain Top Range

A 7-mile mountain top to mountain top elevated range was considered where the transmit antenna was 600-feet above local terrain. For these calculations, a parameter "B" is defined as the total reflected ray attenuation relative to the 0 dB peak value. Note that "B" includes ground reflectivity and the antenna pattern characteristics of the transmit antenna.

In the data of Table E-1, it is seen when "B" is -40 dB or lower, the total field nonuniformity at the receive site is a maximum of 0.17 dB over a 12-foot region. Since SPS subarrays have beamwidths in the order of 0.624-degrees, the realizable value of B for this facility should be significantly lower than -40 dB, thereby providing uniformity for high accuracy measurements.

hr (ft)	B = -10 dB	B = -20 dB	B = -30 dB	B = -40 dB
570.	-14.70927072326	-1.666868821668	-5282305072888	-.1672269792257
571.	-7.428454029982	-1.368290177242	-4436186672515	-.1413706427213
572.	-3.886621613291	-.9425111367539	-3156147356191	-.1015859624166
573.	-1.805078190023	-.516799335368	-1786904359801	-.05812899715107
574.	-.598472884387	-.1884638427282	-.06677790243671	-.02191217595339
575.	-.0463295456109	-.01522928026685	-.005465760870493	-.001802020252939
576.	-.06787037464989	-.02227300612122	-.007989586633897	-.002633593655474
577.	-.6660424599133	-.208636306105	-.07381499309545	-.02420812243616
578.	-1.929334068248	-.5469413182558	-.1886861453726	-.06133312758092
579.	-4.094306065148	-.9766090964453	-.3261907710001	-.1049037563173
580.	-7.797774650291	-1.397322200353	-.4520295012469	-.1439565638627
581.	-15.66507314677	-1.680938745975	-.5321153915358	-.1684057643337
582.	-21.05159924348	-1.721815307004	-.5433503286712	-.1718106340018
583.	-9.467061513061	-1.503334403829	-.4824043308431	-.1532664917155
584.	-5.000058152862	-1.110199655086	-.3670766602808	-.11767792981
585.	-2.470901638549	-.6708702128167	-.2292980719927	-.07429983325471
586.	-.9705253968216	-.2968354048595	-.1043335355511	-.03413623244012
587.	-1.856029676181	-.06035686587956	-.02158989896674	-.007109174501039
588.	.006305033970435	.002081005275045	.0007478234404346	.000246670000223
589.	-.3683104284136	-.118084803179	-.04205945623693	-.01382756711092
590.	-1.362345821063	-.4039861932889	-.1408663600673	-.04595906037366
591.	-3.14251959835	-.8086599019672	-.2735424207034	-.08833253489757
592.	-6.13605692236	-1.2446980437843	-.4080402014416	-.1303935890961
593.	-11.74197564648	-1.597715602748	-.5090036478917	-.1613821796346
594.	-42.44082615244	-1.738443538836	-.5478986910129	-.17318731945
595.	-12.24702938135	-1.612957533444	-.5132604059234	-.1626777499111
596.	-6.371557787551	-1.271582247166	-.4153124096503	-.1326423470825
597.	-3.27996250932	-.8348154599628	-.2818336484658	-.09095136001829
598.	-1.443688774927	-.4253592138931	-.1480825124597	-.04828641612536
599.	-.4091105994103	-.130749903238	-.0465268637559	-.01529100536266
600.	0.	0.	0.	0.
601.	-.1582457558496	-.05156965839547	-.01845865953342	-.006079581698486
602.	-.9056298923289	-.2784044823885	-.09798957095398	-.03207632616855
603.	-2.357381236972	-.6458734805413	-.2211692205834	-.07171103252338
604.	-4.809725471297	-1.084069243803	-.3591479261583	-.1152071779143
605.	-9.107204773002	-1.483598303822	-.4767895350134	-.1515489500674
606.	-19.68648780457	-1.715645129284	-.5416593645221	-.1712985613529
607.	-16.49257287315	-1.690881524248	-.5348552276751	-.1692366674524
608.	-8.099231111111	-1.419385523504	-.4583947651092	-.1459112670758
609.	-4.262069125127	-1.003171504814	-.3343898919862	-.1074720773813
610.	-2.029822964387	-.5708432558125	-.1965795957723	-.06385983817478
611.	-.7214522467641	-.2250147070304	-.07951289276764	-.02606530374806
612.	-.08702326851387	-.02851615954245	-.01022436526313	-.003369658678281
613.	-.03180696981288	-.01046720400865	-.00375798073452	-.001239141269707
614.	-.5482372896123	-.173323276686	-.06148218038038	-.02018272141609
615.	-1.711244779824	-.4936016929856	-.1709660083432	-.055649493999
616.	-3.72943646849	-.9157859356021	-.3072853880637	-.09896906925985
617.	-7.151395310516	-1.344972240863	-.4368343000152	-.1392822528099
618.	-14.02772874841	-1.65480329816	-.524891802356	-.1662133335997
619.	-25.36416173641	-1.732352600858	-.5462340895484	-.1726835992307
620.	-10.36295315128	-1.546226305935	-.4945439633286	-.1569746862849
621.	-5.461899665911	-1.169623669887	-.384984210506	-.1232468610267
622.	-2.745533166243	-.7292656680622	-.248165277598	-.08029576532164
623.	-1.129425024176	-.3411371507083	-.1195101636044	-.03905589269172
624.	-.2565315240383	-.08296471919539	-.02962726531581	-.00974968626312
625.	.01329597493542	.004390764197041	.001578119887	.0005205771172143
626.	-.2824022492655	-.09114828648367	-.03252997870351	-.01070250680738
627.	-1.184893399363	-.3563279289048	-.124690718004	-.04073256365129
628.	-2.840566688716	-.7488026765344	-.2544392764355	-.08228568485293
629.	-5.622461591295	-1.189021611862	-.390792814938	-.1250498373217
630.	-10.68303592552	-1.559614670522	-.4983156694942	-.1581253332211

Table E-1. Relative Field Intensity (in dB) for 4-mile Mountain Top to Mountain Top