

REDESIGN FOR ENERGY AND RESERVE MARKETS IN ELECTRIC  
POWER NETWORKS WITH HIGH SOLAR PENETRATION

A Thesis  
Presented to  
the Academic Faculty

By

P. Taylor Hollis

In Partial Fulfillment  
of the Requirements for the Degree  
Master of Science  
in the School of Electrical and Computer Engineering

Georgia Institute of Technology

December 2011

REDESIGN FOR ENERGY AND RESERVE MARKETS IN ELECTRIC  
POWER NETWORKS WITH HIGH SOLAR PENETRATION

Approved by:

Dr. Santiago Grijalva, Advisor  
School of Electrical and Computer Engineering  
Georgia Institute of Technology

Dr. Miroslav Begovic  
School of Electrical and Computer Engineering  
Georgia Institute of Technology

Dr. Ajeet Rohatgi  
School of Electrical and Computer Engineering  
Georgia Institute of Technology

Date Approved: 8/26/11

## ACKNOWLEDGEMENTS

I would like to thank my parents Howell and May B. Hollis for constant support for my continual education, Dr. Grijalva and all of the members of the ACES lab for sounding out ideas and proving feedback, Drs. Begovic and Rohatgi for serving as committee members, James Marlow and Jamie Porges and the rest of the team at Radiance Solar for their support.

# TABLE OF CONTENTS

	Page
ACKNOWLEDGEMENTS	iii
LIST OF TABLES	v
LIST OF FIGURES	vi
SUMMARY	ix
<u>CHAPTER</u>	
1 INTRODUCTION	1
2 PV COST TRENDS	
2.1- Declining Costs of PV Systems	6
2.2- Cost of PV Systems	7
2.3- Competition and Consolidation	8
2.4- PV Cells	9
2.5- Modules	12
2.6- Balance of Systems	13
2.7- Future Directions	14
3 CONTEMPERARY ELECTRIC POWER MARKET OPERATIONS	
3.1- Introduction to Power System Frequency	16
3.2- Energy Procurement Through Competitive Markets	18
3.3- Regulation Reserves	21
3.4- Primary and Secondary Regulation	22

4 IMPACT OF PV VOLATILITY ON POWER SYSTEM FREQUENCY REGULATION AND ENERGY SCHEDULING	
4.1- Variability of Solar Insolation	25
4.2- Magnitude of Ramp-Rate and Duration	26
4.3- Correlations	27
4.4- Accuracy	29
4.5- PV Volatility Impacts on Power Systems	31
4.6- Seconds to Minutes	32
4.7- Minutes to Hours	33
4.8- Hours to Days	35
5 THE ECONOMIC IMPACTS OF INCREASED PV PENTRATION ON ENERGY AND RESERVE MARKETS	
5.1- Reserves for Renewables	38
5.2- PV Energy Market Participation	39
5.3- Studies on Price Impact of Renewables	41
5.4- Planned Capacity Investments	43
6 AN ENERGY MARKET REDESIGN FOR MANAGING VARIABLE RESOURCES	
6.1- Redesigning the Electricity Market Architecture	47
6.2- Advanced Load Response	49
6.3- Distributed Dispatchable Generation	51
6.4- Motivation for a New Market	53
6.5- Forward Market	55
7 MECHANISMS FOR IMPLEMENTING MARKET REDESIGN	
7.1- New Price Dissemination Scheme	59

7.2- Bus Price Dispatch Algorithm	60
7.3- Price Updates	60
7.4 Remarks on Algorithm	63
7.4- Prosumer Futures Market Mechanism	64
8 SIMULATIONS WITH NEW MARKET PROTOCOLS	
8.1- Bus Algorithm Simulations	67
8.2- Simulations with Solar Data	70
8.3- Results	73
8.4- Remarks	74
9 CONCLUSIONS	
9.1- Benefits	78
9.2- Impact on Electricity Markets	81
9.3- Areas for Future Studies	85
APPENDIX A: SECURITY CONSTRAINED LIMITS	87
REFERENCES	89

## LIST OF TABLES

	Page
Table 1. PV System Costs.	8
Table 2. Cost Curve Coefficients.	68
Table 2. Solar Data.	71
Table 3. Simulation Results.	74

## LIST OF FIGURES

	Page
Figure 2-1. SunShot Goals.	15
Figure 3-1. Frequency Response Window.	17
Figure 3-2. Regulation Response.	23
Figure 4-1. Solar PDFs.	31
Figure 4-2. Texas Wind Event.	34
Figure 4-3. Daily Solar And Load Curves.	35
Figure 4-4. Solar Capacity.	36
Figure 5-1. Merit Order Effect.	41
Figure 5-2. MOE Price Simulation	42
Figure 5-3. Load Duration Curve	44
Figure 6-1. Forward Prices.	57
Figure 6-2. Demand Elasticity Prices.	58
Figure 7-1. Price Update Algorithm Flow Chart.	63
Figure 8-1. Simulation Configuration	67
Figure 8-2. Price Curves and Prices.	68
Figure 8-3. Price Convergence Simulation.	69
Figure 8-4. Price Convergence with SCL Change.	70
Figure 8-5. Simulation 3.	72
Figure 8-6. Simulation 5.	72



## SUMMARY

Favorable price trends and increasing demand for renewable energy sources portend accelerating integration of solar photovoltaic (PV) generation into traditional electric power system networks. Managing the variable output of massive PV resources makes system frequency regulation more complex and expensive. ISOs must procure additional regulation and load following capacity, while power plants must supply more regulation work. In contrast to costly physical storage solutions, this thesis proposes to address the issue by reconfiguring the electricity market pricing structure to translate all power imbalances into real-time market price signals. More accurately determining the instantaneous value of energy, electric power markets could reward participants who can quickly respond to frequency fluctuations. By utilizing short term forward markets to monetize the risk associated with intermittency, the true cost of reliability is determined and could reduce wasteful capacity payments. This market redesign is an ideal open platform for disparate smart grid technologies which could encourage all suppliers, loads and generator, to offer supply or reduce consumption when it is needed most and could vastly improve frequency performance metrics.

## INTRODUCTION

Solar energy resources offer the potential for cheap, clean and virtually unlimited electricity for mankind. To date, the high price of these technologies has limited its adoption to markets with generous government subsidies. Currently, however, industry trends of innovation, consolidation, increasing economies of scale and competition are lowering the long-term cost of electricity produced by solar resources. Optimistic predictions call for solar systems to produce power on parity with traditional sources by 2020 [1].

While the discovery of the photovoltaic effect dates back to the French scientist Alexandre-Edmond Becquerelin in 1839, the technology did not see significant deployment nor large research efforts until the space program of the 1960's, when it was developed to power satellites. In recent years the world has witnessed a spate of environmental, humanitarian and economic disasters caused by energy projects. The Gulf of Mexico oil spill destroyed marine life of unfathomable proportions, tens of millions of Chinese peasants were displaced by the Three Gorges dam construction, and the Fukushima nuclear power plant disaster has contaminated a region for an entire generation. Each event further increases the urgency to produce electric power in a cleaner and safer fashion. In response, citizens worldwide have petitioned and many have successfully

convinced their governments to support PV and other renewables as alternatives to traditional power production methods.

Some governments, such as Japan's and Germany's, are making extremely aggressive efforts towards increasing solar energy's role in their energy security planning, as a method of diversifying energy portfolios away from fossil fuels, coupled with a desire to reduce purchases of imported oil and gas from tyrannical regimes. Thanks to these subsidies, the industry is booming. Cumulative grid-tied PV capacity in the U.S. grew to 792 MW by the end of year 2008, with an 53% and 81% increase in new grid-tied PV installations in 2007 and 2008 respectively [2].

From environmental and energy security perspectives, PV is *the* ideal source of electric power. After installation, there are *no* pollutants, *no* radiation, *no* noise or blights on the landscape. The potential supply is unlimited for practical purposes. The average total amount of solar radiation striking one square meter over a year is around the same as the energy content of a barrel of oil. The primary input of the prevailing technology, crystalline silicon, is the 5th most abundant element in the Earth's crust

On the other hand, the processes of purifying the silicon to semiconductor grade quality, creating wafers, cells and modules for a PV panel then installing them and connecting the system to the grid remains the most expensive form

of power that is currently used on a utility scale. This has been the story of PV systems to date. The promise from the industry is that it won't always be the case. "If we aren't reducing system costs by 20% a year in order to reach grid parity in ten years this has all been a big science experiment," says Jon Megna of SMA, the world leader in PV inverter sales.

Ambitious renewable energy goals and quickly dropping prices are resulting in a flood of PV into power systems. PV is graduating from its current status as a minor power source, viable only via government support, and entering one in which it is a significant part of grid generation and participate in energy markets and provide support services to the grid like other generation sources. The power industry has made significant progress in creating standards for distributed generation and systems are incredibly safe and reliable. However, to date these rules have assumed that PV systems played a passive role in power systems, i.e. they do not attempt to regulate grid parameters. In the event of voltage or frequency disturbance, PV systems are required to disconnect from the grid. This means that solar, for all intents and purposes, is a negative load, not generation. Due to its present role as a minor power source and governments' desire to see it succeed, solar has not been required to provide these functionalities, but that is starting to change. As an indication of PV's maturity, in Germany, where PV has been vigorously supported for decades and

2% of energy came from PV in 2009, regulations were issued in 2010 that require PV plants to inject reactive power and be able to be separated from grid by a centralized control center [3].

As penetration levels increase beyond 10%, many power systems planning methodologies need to be reconsidered. Engineers and regulators will need to look beyond the point of interconnection and consider system-wide impacts. The growth of solar energy will have financial, physical and computational effects on power systems operations and these areas are very much interrelated, such that altering the policies in one area may have unintended consequences elsewhere. Accordingly, academic research, integration studies and regulatory policy recommendations must be approached from a highly interdisciplinary perspective.

This thesis concerns examines the impacts on long term capacity planning, real time prices, and power systems frequency regulation, and what system planners and market regulators can do to ensure continued grid reliability. Following the introduction, Chapter 2 indentifies the physical sources of PV costs and key drivers of PV's quickly dropping price. Chapter 3 briefly reviews how operators utilize competitive markets to schedule generation and regulate system frequency. Chapters 4 and 5 discuss the metrics of PV variability and how system frequency will be impacted by the flood of PV into

power networks. Chapter 6 proposes a market redesign to counterbalance the intermittency of these resources, namely allowing energy markets to naturally determine the value of this power given its undispachable nature. Chapter 7 introduces an advanced computational structure to disseminate prices extremely fast in order to encourage competitive participation from technologies such as advanced load response, backup generation and combined heat and power. In Chapter 8, simulations are performed to demonstrate that such a redesign could vastly improve frequency regulation performance by effectively assigning prices to grid participants based upon the value or cost of their net contribution.

## CHAPTER 2

### PV COST TRENDS

#### 2.1 Declining Costs of PV Systems

The amortized price of electricity generated by PV systems is falling rapidly. In 2009, average system prices dropped up to 33% [4]. For the past decade the semiconductor industry has been firmly geared toward supplying the IC industry. PV systems have been using retooled or custom made equipment, at a resultant higher cost for lack of options. Similar costs presented themselves in the inverter and installation stages. Finally, for the first time in 2005 the PV industry consumed more purified silicon than the IC industry [5]. As experience and expertise increase each year, the lessons learned are passed across the industry among manufacturers, wholesalers, and integrators. Today, throughout the value chain, the industry is reducing final retail costs by eliminating redundant intermediaries, integrating processes, and consolidating buying power.

Government support in the form of rebates and tax credits is finally paying off. Industry growth itself is now the greatest vehicle of cost savings. The effect of having positive returns to scale allows prices drop, which then induces greater demand. The upshot of this virtuous cycle is that the industry has attained the critical volume which encourages other industries to dedicate

themselves to providing third party solutions. As governments slowly remove subsidies it will unleash the most crucial component of long term price decreases, competition.

## 2.2 Cost of PV Systems

PV systems are most often discussed in terms of price per watt of installed nameplate rated DC power. Current prices for residential, commercial and utility are generally around \$6, \$5, and \$4 per Watt installed, respectively. For reference, \$1.5 per watt (\$/W) is around the breakeven point with traditional power sources without government incentives.<sup>1</sup>

Table 1 lists the costs per watt for a 100 kW PV system in Alpharetta, GA in December, 2010. It is immediately evident that the PV modules comprise a very large portion of the total costs [6]. Consider that modules now cost around \$2.0/W, whereas the inverters \$0.35/W, or six times the cost for the same power rating in two devices with similar complexity. The main culprit: continually high cost of purified silicon feedstock.

---

<sup>1</sup> 8% discount rate, 1%/yr degradation, \$0.02/kWh maintenance, 20% annual cost reductions and initial cost of \$3500/kW.



Table 1. PV System Costs.

Item	Price (\$/W)	% of Total
Modules	2.1	0.59
Inverters	0.35	0.10
Wiring/Conduit	0.1	0.03
Racking	0.3	0.08
Electrical	0.4	0.11
Mechanical	0.1	0.03
Taxes/Permits	0.1	0.03
Overhead/Margin	0.1	0.03
Total	3.55	1.00

### 2.3 Competition and Consolidation

Unlike the wind industry, where there are only a dozen or so manufacturers of multi-megawatt wind turbines, there are currently hundreds of producers of solar modules each with dozens of a different cell technologies. This variety has its pros and cons. Competition is good for the industry-wide, long-term price trends, as expensive technologies are quickly surpassed by more cost-effective ones. Additionally, the distinct research approaches are healthy for ensuring that there is "no stone unturned," and that all potential technologies all adequately explored. On the other hand, each stage of the production chain has remained fairly generalized for different products which prevents economies of scale and efficiencies.

The large number of firms, however, is slowly being reduced through attrition and consolidation. Prompted by the recent downturn in PV demand during the global recession, there has been a wave of bankruptcies in the

sector, particularly from the firms that mistimed the crash in silicon prices. Because it is often more expensive to incorporate differing technologies under the same ownership, surviving firms are expanding their own production lines by investing in new equipment based on the latest technologies or going after different segments of the business. Several manufacturers such as First Solar and Sunpower are now completely integrated from cell manufacturing through module assembly, all the way to system installers. "Vertical integration has become PV companies' dominant development mode and it's the trend they will need to end up following," said Gao Jifan, CEO of Trina Solar, a world leader in cell and module manufacturing [7].

## 2.4 PV Cells

Worldwide, the PV market is split into thirds by three major technologies. Monocrystalline silicon is the efficiency leader with production cell efficiency 17-19%. Polycrystalline is a cheaper alternative but with lower efficiency (15%). Various thin-film technologies (~8-10%) leverage low cost production over efficiency by use special depositing techniques to create extremely thin layers of PV and saving on material costs. In 2008, both crystalline silicon technologies commanded c.a. 85% market share. Silicon PV cell production can

be summarized in the following steps purification, wafer, and cell fabrication, with respective process costs around \$0.50, \$.20, \$.18 per watt.

Silicon is not the only material from which PV cells can be made. First Solar's cell, the cheapest largest produced technology on earth, is a cadmium telluride technology with 10% efficiency. Also, dual and triple junction solar cells made with germanium and indium-gallium-phosphide layers hold a record efficiency of over 32%, but these are too expensive for deployment except in concentrated solar power applications. While other methods hold very real promise, this overview will focus on silicon technologies as they comprise the bulk of research efforts and currently manufactured supply.

There are many reasons for the dominance of crystalline silicon in PV. It is widely available around the earth, is a very well-understood material, uses the same technology developed by the semiconductor industry for integrated circuits, has stable performance, and mostly non-toxic materials are used in the final product. Today, significant new capacity for silicon purification and wafer fabrication have recently come online and hundreds of companies are churning out excellent products at a continuously falling cost. In 2009, China boosted polysilicon manufacturing to 10,000 tons annually and has recently announced plans to increase that production [8]. The cost of silicon has gone from more

than \$200/kg in 2007 to \$50/kg in 2009, but prices are now rebounded in tandem with the economy.<sup>2</sup>

The industry is in a stage of hyper growth, where new technology developments can catapult new entrants to the top of the sales pyramid, albeit that position is precarious to defend for the self same reason. Vinod Khosla, a green tech entrepreneur, commented, “Many of the high profile thin film startups will also fail to get enough of an advantage to overcome First Solar's head-start on scale, manufacturing optimization, experience learning and cost. They will fail to compete in the near future, and by the time they get to their 'second generation' a new Black Swan improbable pyro-nano-quantum-thingamajig technology will disrupt their new plateau” [9]. Here, Kholo is explaining that efficiency alone is not enough. Originally designed as a source of power for satellites, cell designs are being reconsidered to reflect the most important factor: cost per watt. The theoretical efficiency of a crystalline solar cell is only 25%. With production efficiencies already above 20% researchers are coming up with creative ideas to increase efficiencies without increasing manufacturing costs. This progress is like a marathon in that the last mile hurts the worst. For example, in response to high silicon prices wafer manufactures have lowered thicknesses from 200 to 180 microns by using diamond saws and

---

<sup>2</sup> Most silicon is purchased through secretive bilateral contracts and a spot price is not representative of transaction prices.

water coolant. However cell thicknesses of 140 microns enters mechanical failure region.

## 2.5 Modules

Current value-add for modulization is approximately \$.40/W, but this has come under extreme pressure from Chinese manufacturers. In response, manufactures are developing new products to reduce installations costs. Ease of installation is critical as PV plants constitute tens of thousands of modules installed by hand. A carefully designed mounting mechanism can save tens of thousands of man hours on a megawatt project. An example of these trends is the Sunpower T5 Sun Tile, the latest and most elegant version of self-ballasted<sup>3</sup> PV systems and a hallmark of what products can be expected from the industry. The module frames are made of synthetic material, so do not require a grounding conductor or lightning protection. An improved aerodynamic design which allows the modules sit right on the roof. Labor and material savings for installation are greater than 80% [6]. Products like these are trending toward the eventual goal of the concept of Building Integrated PV where huge cost savings will be incurred when the PV also plays a function role like glass for the window. Products are being introduced in both the residential and commercial

---

<sup>3</sup> These are systems that are not attached to a roof mechanically, but instead are engineered to lay on the roof with only minimum added weight.

markets, co-developed by PV manufacturers and roofing materials manufacturers that will carry the same roofing performance that customers expect, but with the added benefit of producing electricity.

## 2.6 Balance of Systems

As module prices continue to fall, Balance of System costs (system costs excluding panels, overhead and margin) reductions are keeping pace. System installation is moving from a cottage industry to a fleet of well trained professionals. Human know-how, from improved electrical/mechanical design standards to electricians' familiarity with PV is growing and installation procedures are being simplified. Municipalities and utilities are streamlining their application processes. Utility engineers and inspectors are gaining specialized knowledge and are increasingly well informed, Applicable codes (IEEE 1547, UL 1741, and NEC 690) are becoming more straightforward, and consistent. Preconfigured buildings, know as “Solar Ready”, which leave conduits for electricians to later pull conductors, and locations on roofs for attachment are becoming popular.

PV Inverter, second largest single cost after modules, costs are currently dropping by nearly 20% per year, mostly through enormous gains in scale. Entire inverter plus high voltage transformer units for multi-megawatt projects

are now being shipped preassembled in standard freight containers for cheaper shipping. This reduces installer on-site installation to virtually zero. All the equipment is preconfigured, tested and UL approved. Additionally, inverter manufacturers have received UL approval to sell transformerless inverters in the US. Removing the transformer lowers equipment costs and shipping weight. These inverters permit higher string voltages as there is no conductor above the maximum 600V to ground, which in turn produces lower DC currents, improves efficiencies, and requires less wire. With no transformer core losses, these inverters are pushing 98% efficiency at a lower price tag.

## 2.7 Future Directions

Government support for PV to date has been to give blind support to encourage system installation. Today, governments are taking more carefully aim at the lingering chokepoints for massive price reductions. The Sunspot Initiative is a collaborative national effort funded by the D.O.E. to make solar energy technologies cost-competitive with other forms of energy by reducing the cost of solar energy systems to \$1/W by 2020.

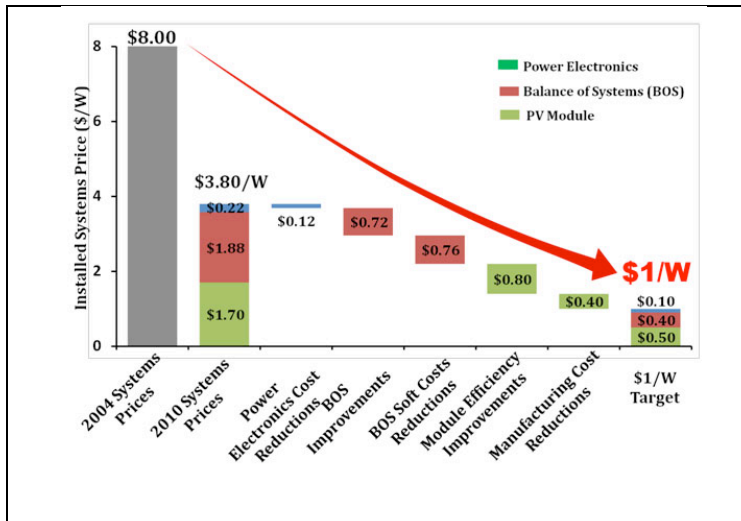

Figure 2-1. Sunspot Goals [10].

A \$1/W system cost is ambitious and would make PV very competitive with traditional sources. Such a scenario could be broken down to \$0.20/W for wafer production, cell processing \$0.15/W, modulization \$0.15/W, and BOS \$0.50/W. There is certainly room for this to happen. There remain high margins at chokepoints that have command oligopoly prices. Silicon wafers still cost more than \$0.8/W, which for reference is more First Solar's entire module cost. Now, more than ever, the sense is growing that PV will become price competitive. As the virtuous cycle of scale, demand prices and competition heats up prices will keep dropping faster and faster.



## CHAPTER 3

### CONTEMPERARY ELECTRIC POWER MARKET OPERATIONS

#### 3.1 Introduction to Power System Frequency

Electricity is a unique commodity; production and consumption must be matched instantaneously and continuously. In systems with machine based generation sources order to maintain system frequency, the mechanical torque being delivered to the rotor of an electromechanical generator must match the opposing electrical torque applied via the stator current. Any net torque will increase or decrease the generator's rotational kinetic energy. The magnitude of this acceleration depends upon the quantity of the power mismatch, and the inertia of the turbine-generator. Networked power system frequency responds similarly with the sum of the inertia of all of the generators and loads within the system replacing the rotor inertia. The quantity of kinetic energy stored in the rotor is only enough to sustain the grid for several milliseconds to a few seconds, depending on the amount of imbalance between load and generation.

Maintaining power system frequency at constant value is a critical element of reliability for both the correct operation of power generating equipment and power quality at the customer's end. The effects of off-nominal power system frequency on components and users differs widely. If a rotating machine spins at or near one of its resonant modes mechanical vibration

damage can occur. A violation of a generator or transformers' volts-per-hertz limits will cause the core laminations to overheat and eventually fail. Most critical for the power system security is the maintenance of synchronicity between generators. The effect of the sudden loss of a large generating unit is felt nearly instantaneously throughout an interconnection as an immediate decline in system frequency. Poor frequency regulation can result in fluctuations which create discrepancies in power angles, and evolve into inter-area power oscillations. Transmission lines may be overloaded when various generators try to restore system frequency. Generator protection may trip to prevent damage, which will exacerbate the overall generation-load imbalance. Most often these effects occur at the same time and can lead to a cascading collapse of the power system. Figure 3-1 displays a typical system frequency response window.

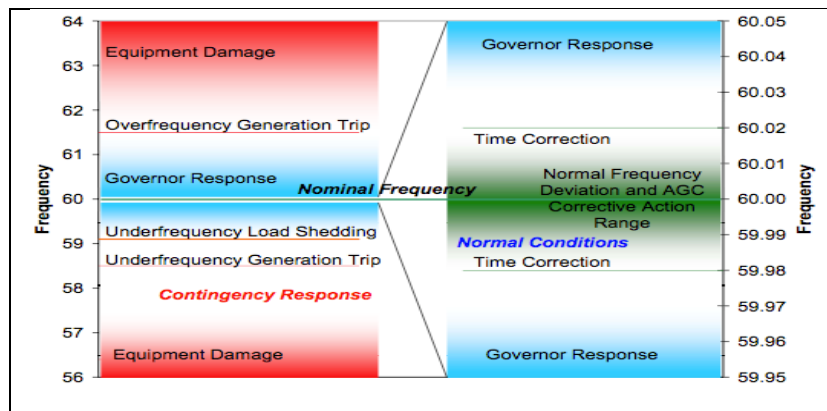

Figure 3-1. Frequency Response Window [11].

When the integrity of the interconnected power system has been severely compromised, two portions are separated automatically by the triggering of protective devices if their respective frequencies differ substantially and operate as electrical “islands” distinct from one another. If control actions are unable to arrest a decline in frequency, a more extreme measure, under-frequency load-shedding, will be initiated automatically. Under-frequency load shedding disconnects large, pre-set groups of customers at predetermined frequency set points. It is a blunt and drastic form of emergency frequency control, intended to prevent damage to equipment during the extreme imbalances in frequency. This comes at great cost to both customers and utilities.

### 3.2 Energy Procurement Through Competitive Markets

Independent System Operators (ISOs) are corporate or government entities tasked with two simultaneous goals; 1) to maintain the reliability of service through planning processes, regulatory policies, and real-time system regulation; 2) to run the system at its lowest cost operating point. In controls areas where there is a monopoly provider, the monopoly performs this functions internally. ISOs use markets to achieve that goal through a process known as a security constrained optimal power flow (SCOPF). This methodology results in

the most economic use of resources available in the market at any given moment, subject to generator costs, transmission topology and constraints, and contingencies.

The economic dispatch stage begins with an ISO taking competitive bids and offers from generators and loads 24 hours before each operating hour. Bids are a function of the generators' cost curves, including fixed and variable operating costs and are required to be convex functions. The ISO places the bids in the ascending order from least to most expensive. This is known as the Merit Order. Over the course of a given day, as the load increases the ISOs moves through the Merit Order to dispatch power plants, when transmission limits are not constraining dispatch.

Next, the ISO considers the realities of transmission limits and optimizes the system dispatch to ensure that no transmission lines or transformers are overloaded. Additionally, transmission losses and voltage constraints are considered. Limitations in transmission capacity require that more expensive generation be dispatched closer to the load, and are generally the constraints that are the primary obstacle to minimizing the overall supply cost. Cheaper sources, "base load" units, such as nuclear and hydro generators are located far from major load centers and must be supplemented by smaller "peaking" units which are downstream of transmission bottlenecks.

Next, the operator considers contingencies, such as line or generator outages. Given a certain condition, say Line #1 is shorted, no other equipment should consequently be overloaded from the redistributed power flow. The maximum power that a line may carry without damaging other system elements in a contingency is known as the security constrained limit and may be considerably lower than the line's thermal limit. The system is referred to as secure if it is resilient to a contingency that removes an element such as a transmission line or generator. If the security analysis indicates that the economically optimal unit commitment cannot be carried out reliably then more expensive generators must be committed for that time period. The process of considering the impact of an contingency and mitigating its effects is iterated until a secure solution is found. The outputs of the SCOPF process are the security constrained line limits and the Locational Market Prices (LMP) for the system.

During operations, the SCOPF process is carried out in five minute intervals to provide generators set-points that reflect real time conditions. The highest variable-cost unit that must be dispatched to meet load within transmission-constrained boundaries sets the LMP for energy in that area. As the name implies, the LMP defines the marginal cost of serving the next increment of load at a location. If there are no transmission constraints between

two buses, the LMP will be the same for both locations. All sellers in the area receive this market-clearing price for energy and all buyers in the area, who are not in bilateral contracts, pay this price.

### 3.3 Regulation Reserves

In anticipation of the diurnal rise and fall of load, ISOs create day-ahead and hour-ahead load forecasting to accurately schedule ramping up and down of generation. Because of electricity's unique characteristics, additional reserve capacity (reserves), must be procured in case actual conditions in the real-time dispatch stage vary from those forecasted or there is a disturbance in the power system which prevents the scheduled generation from being dispatched. The system operator is responsible for purchasing these reserves on behalf of the users of the system.

In some markets all generators are required to be responsive to system frequency deviations as a condition of being allowed to connect to the grid. In that case so-called capacity payments are paid to reimburse generators that hold important strategic resources. Others reason that some generation will be in better position technically and economically to provide frequency response and allow the market to determine the best resources to use. Either way, the service of providing regulation has costs. These include; the capital cost of

building plants with extra capacity, the opportunity cost of not using them to provide energy into the market, wasted idling power and emissions cost, lower heat rates<sup>4</sup>, work cost of regulation, and shortening lifetimes due to increased mechanical stresses on the equipment from ramping

### 3.4 Primary and Secondary Regulation

As part of interconnection agreements, generators are usually required to autonomously and rapidly change output to oppose large changes in frequency. If the load changes by  $\Delta P_e$ , then the governing system senses changes in frequency and adjusts a control valve until mechanical power matches load. System frequency will change at the rate  $\Delta P_e / M$  until  $P_m = P_e + \Delta P_e$ , where  $M$  is the system inertia. This primary regulation, or "droop", is defined by the amount of frequency change that is necessary to cause the prime mover (mechanical input to rotor) control to move from fully closed to fully open. The most important quality of primary frequency control action is the rate at which power increases over the initial 15 or so seconds following the loss of generation [12]. If sufficient amounts of power are not injected promptly, frequency will not be arrested before declining to a point at which under-frequency load shedding is triggered. The frequency nadir, the lowest point the

---

<sup>4</sup> This is a result of headroom, or capacity above the operating point to increase output. The mandate of headroom may decrease the energy and emissions efficiency of generators that are optimized for maximum output.

system frequency reaches before stabilization, is progressively higher as rate of delivery of primary frequency control increases. Figure 3-2 shows how frequency is arrested at its nadir by primary regulation it is then brought back to 60 Hz by secondary regulation.

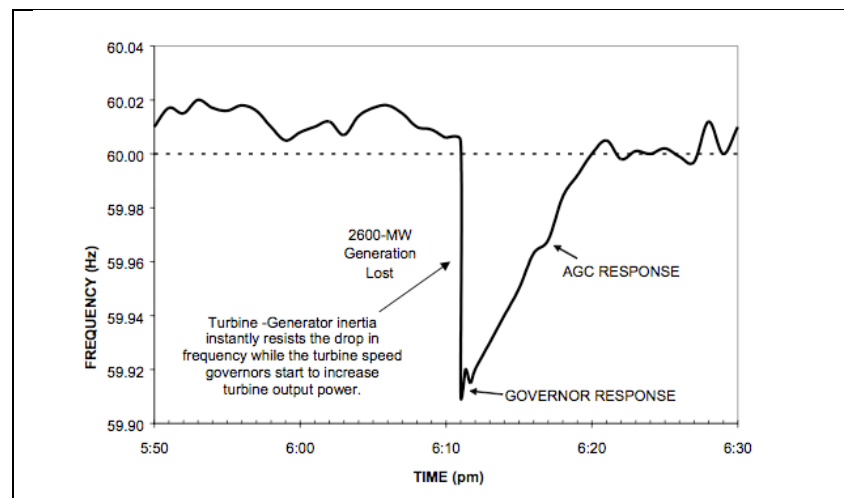

Figure 3-2. Regulation Response [11].

Secondary frequency control involves slower responses from tens of seconds to minutes which are centrally directed and drive the area control error (ACE) to zero. ACE indicates each area's the reaction to the change of scheduled tie-line capacity  $\Delta P_{\text{Scheduled}}$  and change of system frequency. It is given by,  $ACE = \Delta P_{\text{Scheduled}} + \beta * \Delta \omega$ . where the coefficient,  $\beta$ , is known as the system natural response coefficient. This characteristic is expressed as  $1/R+D$ , where, R is the generator droop, and D is the load damping characteristic. Together



primary and secondary regulation act like a PI control. Primary controls role is exactly that of a proportional controller, i.e. to meet changes in load with a proportional increase in generation. Secondary control's role then is to reduce the error back to zero.

## CHAPTER 4

### IMPACT OF PV VOLATILITY ON POWER SYSTEM FREQUENCY REGULATION AND ENERGY SCHEDULING

#### 4.1 Variability of Solar Insolation

The output of PV plants is necessarily variable because the magnitude of solar radiation reaching the Earth's surface changes every moment of the day, and throughout the year. The rising and setting of the sun can induce greater than a 50% change in terrestrial insolation over a period of 15 minutes. Unlike the motion of the sun, which affects the output of PV plants in an extremely well known manner, changes in ground level insolation due to cloud cover are driven by highly nonlinear processes and are responsible for the most rapid and unforeseen changes in the output of PV plants. Understanding a control area's PV variability requires compiling time-synchronized insolation data over spatial scales ranging from several to tens of thousands of square kilometers and time scales of seconds to years in order to create databases for time series analysis. From that analysis, a system operator can abstract the important facts; i.e. the magnitude of power that may be added or subtracted from the system, the ramp rate, the duration, the correlations between different geographic locations, and the error in forward predictions.

## 4.2 Magnitude of Ramp-Rate and Duration

Changes in solar insolation at a single point due to passing clouds can exceed 50% of the peak insolation in a matter of seconds. Fortunately, for PV systems the isolation over the PV plant is 5-10 orders of magnitude large than a single pyranometer, and changes much more slowly on short time scales. This is easy to understand in terms of the power density of PV and cloud speed. A typical power density for PV is around  $15/m^2$ . If the speed of an approaching cloud is limited to 25 k.p.h., and the cloud is assumed to completely block all radiation, then for PV systems of 0.1, 1.0, and 10 MW, output is reduced by 10%, 1.0%, and 0.1%, per second, respectively. Additionally, circuit elements in the inverters filter high frequency output. For a multi-megawatt PV plants, 1 second, 10 second, and 1 minute ramps are approximately 60%, 40%, and 10% respectively less severe than those observed at a single point [13]. Data from a 13.2 MW plant in Nevada shows a 75% point insolation change in 10-seconds produced only a 20% power ramp for the plant [14]. Thus we can see that a timescale on the order of minutes is enough time for a 1 MW plant to go from full power to zero and plant ramp rates can be approximated around 1 MW/min per MW installed. As the time scales increase the readings of insolation meters and power plant outputs converge as clouds cover the entire array.

During the winter months, solar radiation must traverse a longer path through the atmosphere at a steeper incident angle, increasing scattering and reducing output of all PV plants by 15-40% from the summer peak depending on latitude. Similarly, weather events range from a passing cloud, to a storm, to massive weather systems that may linger for days. During those periods system planners must have additional power sources to replace solar output. It is very crucial for system operators to know the duration of the change in output be they minutes or days as the difference will have a significant impact on dispatch economics.

### 4.3 Correlations

The impact on the power system of weather events in different locations and times varies dramatically. An operator is not concerned with the insolation levels with the whole control area but specifically where the PV is located, how those sites are correlated, and how they are connected via the transmission system. The degree of correlation between points or plants can be characterized by the relative increase or reduction in the magnitude of ramps for the aggregate of multiple plants over larger areas. This relationship must be viewed as dependent on other factors such on the nature of the weather systems and the time of year, day, etc.. For example, larger weather systems

tend to correlate all plants strongly, while smaller cloud groupings only affect specific locations.

Geographic diversity of renewable resources reduces the variability of their combined output such that power output fluctuations are likely to be relatively small. We can view an estimate of output as a normal distribution with standard deviations  $\sigma_0$ , around some mean,  $\mu$ . The coefficient of variation,  $C_v$ , is a normalized measure of dispersion of a probability distribution and is the ratio of the standard deviation to the mean. When variations over a particular time scale are uncorrelated between  $N$  plants, the aggregate coefficient of variation is expected to scale like  $1/\sqrt{N}$  relative to the variability of a single point.

$$\sigma_{Tot} = \sqrt{\sum_i \sigma_i^2} = \sqrt{N \cdot \sigma_0^2}$$

$$C_v' = \frac{\sigma_{Tot}}{N \cdot \mu} = \frac{\sqrt{N \cdot \sigma_0^2}}{N \cdot \mu} = \frac{C_v}{\sqrt{N}}$$

A study which combined PV plants located 12.5 km to 50 km apart in Arizona showed a 50% reduction in the 99.7th percentile of the most severe ramps by aggregating any pair of sites for 10-min ramps. This is the reduction that would be expected if the ramps at each site were uncorrelated [15]. Data from the Great Plains region of the U.S. indicates that the spatial separation between plants required for changes in output to be uncorrelated over time scales of 15, 30, and 60 minutes intervals is on the order of 20, 50, 150 km

[16]. These sites are therefore uncorrelated for this timescale, geographic extent and weather system. On the other hand, data compiled from aggregating the output of two PV plants in Colorado along the same mountain ridge, 8.8 km apart showed a high correlation in indicating that data sets from multiple regions need to be analyzed and compared to determine the extent to which local features affect the smoothing benefits of geographic diversity [17]. While increasing the geographic diversity of PV plants over larger areas helps reduce their variability output, these separated units cannot necessarily be pooled in a practical power system where there are limitations due to transmission capacity. Operators must share information with neighboring operating areas regarding their solar installations, to understand the cross correlations.

#### 4.4 Accuracy

If ISOs could exactly determine the future variations in PV output it would be challenging enough for frequency regulation to meet these variations. Unfortunately, given the costs and difficulties, there will always be some error in forecasts to account for. For any meteorological prediction there are limitations set by the sensitivity of measurement devices. To date, sophisticated and widespread forecasting of solar systems has not been warranted and wide-area solar data coverage is available with either low time resolution from satellite

images covering a large spatial extent or high resolution data with limited spatial coverage from pyranometers. Additionally, every geographic location has its own weather patterns and requires a unique meteorological model. Although modern radar techniques can accurately predict the quantity of water vapor approaching a region, using numerical weather models to predict how clouds will redistribute themselves over long time scales is still plagued by significant errors due to incomplete modeling.

The error for the average production over an operating window decreases as the operating window increases. Conversely, the error increases as the forward time before the operating window increases. For example, the error for yearly output for a fixed tilt solar system is around 3-5% for a prediction made on December 31 of the previous year [18]. On the other hand, a one year forward prediction of a single day's output is essentially nothing more than a blue sky model of output prediction and may have errors up to 85%. This makes running market simulations to determine correct levels of capacity very difficult.

Holding the forward time and time window constant, error in a prediction also is a function of the correlation between the PV system under discussion and weather system about which the Solar Power Producer (SPP) has information. As we have seen the correlation has a range, and the impact on individual plants can differ largely. Figure 4-1 depicts expected output and the

degree of uncertainty from a SPP in the form of probability density functions (pdf). Estimates for one, five and ten minutes exemplify how the error and consequent spread in the SPP's pf increases. Additionally, output is predicted for the next operating hour in conditions where cloudy weather is moving in or the sky is clearing up. The spread in output predictions for the cloudy hour depicts the uncertainty in the correlation to the weather system.

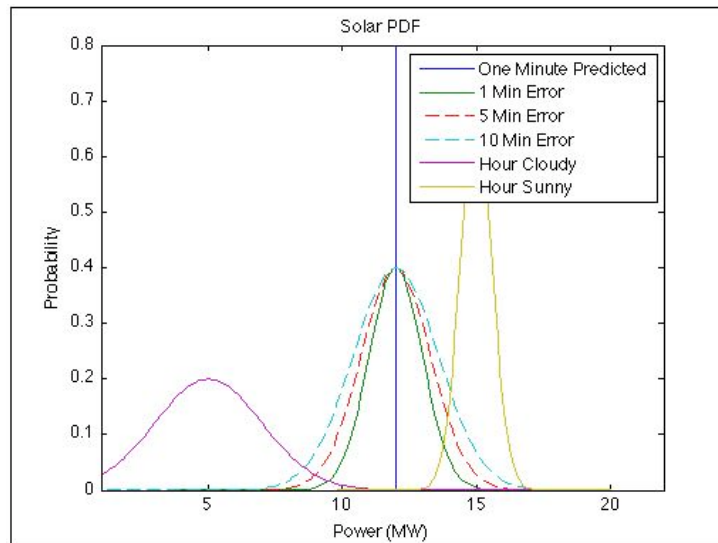

Figure 4-1. Solar PDFs.

#### 4.5 PV Volatility Impacts on Power Systems

We have noted that If a collection of solar resources is large enough and spread over hundreds of square kilometers then sudden, drastic fluctuations should be extremely rare. However, as the aggregate generation increases, the magnitude of ramps will grow and duration of depressed output will remain



constant. Advance predictions of the available power are probabilistic and it is possible that, for a large degree of penetration, many producers in an area may have correlated erroneous forecasts which may develop into a large disparity between real time power in a region and that forecasted. In the following, we would like to consider scenarios where up to 20% of the network is powered by PV, and the aggregate fluctuations in output can have serious impacts on the network frequency. Forecast errors add costs to running the system in terms of unnecessary reserve capacity procured and extra work costs for imperfect and inefficient regulation.

In order to appreciate the impact of variability of solar insolation on power systems we will classify them into 3 timescales; second to minutes, minutes to hours and hours to days timescales. From seconds to minutes we are in the realm of conventional frequency regulation and are seeking fast acting solutions to maintain stability. When we move to time scales longer than several minutes we are seeking a combination of regulation and load following. Beyond one hour we are exclusively seeking economic solution to the dispatch problem.

#### 4.6 Seconds to Minutes

The rapid ramping of renewable generation output is not considered an event comparable to the sudden loss of generation from a large generator.

which begins to affect system frequency within less than a second. Extreme ramps in wind or solar output evolve over minutes. We have discussed the role of geographic diversification and its effect on smoothing extreme point ramps. Despite the fact that PV is unlikely to have much impact on the system at the sub-second scale by means of fluctuating power output, it's presence will be felt in terms of system inertia, or lack thereof.

Renewable generation, which is interconnected via an inverter, will lower system inertia. Many wind turbines and all PV plants are connected via inverters and contribute no inertia. As discussed in Section 2.1, lower system inertia means that the sudden loss of a given amount of generation will cause system frequency to fall faster than it would in a system with higher inertia. Therefore, to arrest and stabilize frequency at a given frequency a power system with lower inertia will require faster and larger provisions of power from primary frequency control actions. However, wind and solar power systems are currently not equipped to take the action necessary to provide primary frequency control, hence the reserves for primary frequency control must be procured elsewhere.

#### 4.7 Minutes to Hours

While load changes tend to cancel themselves out on small time scales, solar fluctuations may be much more highly correlated. The net sum of demand

and solar changes can lead to larger short term frequency deviations. These will appear to the system operator as increased secondary reserve usage with corresponding energy and equipment fatigue costs from rapid generator cycling. Stability concerns emerge when the procured secondary reserves prove to be inadequate, and primary frequency control must be utilized. The remaining reserves for primary control are then depleted and incapable of arresting frequency following decline the sudden loss of generation. Figure 4-2 provides an example of these interactions from a wind event in 2010 in the Texas interconnection.

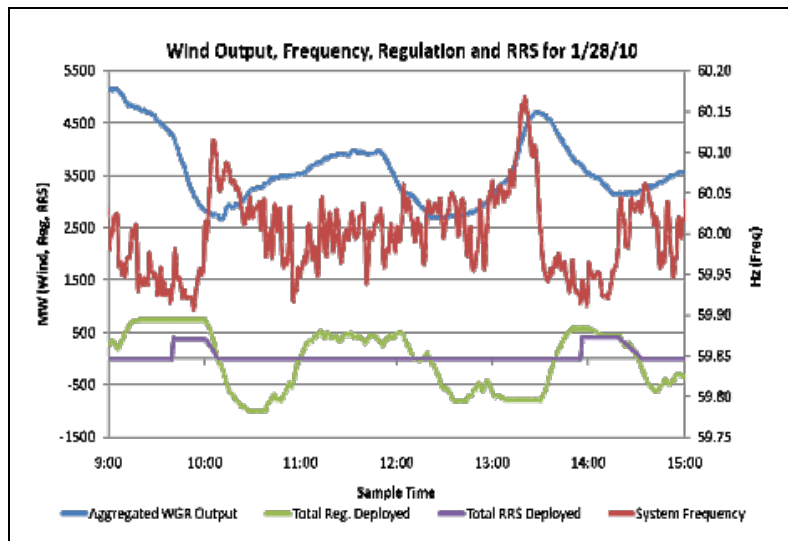

Figure 4-2. Texas Wind Event. Source: ERCOT, 2010.

Two downward ramps of wind began at approximately 9:00 AM and 1:30 PM.

The secondary frequency control actions taken by regulation alone were unable

to arrest the decline in system frequency and primary control reserves were to deployed to restore frequency at approximately 9:40 AM and 2:00 PM.

#### 4.8 Hours to Days

As the time before the operating minute lengthens the dispatcher has more generation options available to respond with. In this case the operator will not call up reserves but use schedule generation in the energy market to meet load. Counter ramps, defined as net power change when demand and solar vary in opposite directions, may be very severe during evenings when the load has its second peak and solar is virtually gone for the day. Figure 4-3 shows how the load following capacity requirements will increase as there will be very large evening ramps when workers return home and turn on lights after the sun has set.

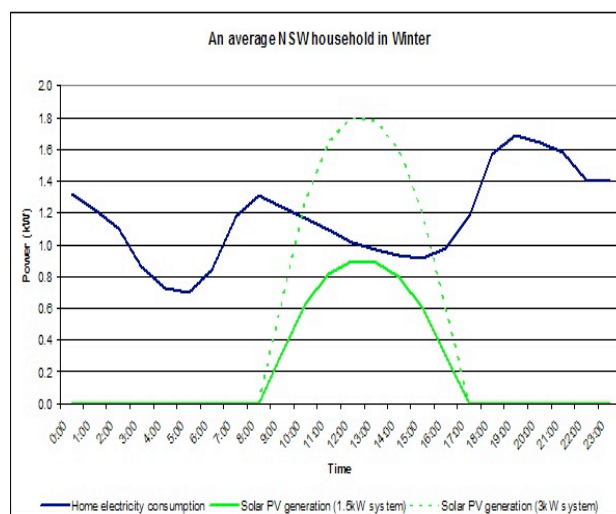

Figure 4-3. Daily Load Versus Solar Curve [19]

Fortunately, this effect is relatively slow, very predictable, and is mediated by neighboring areas. Because neighboring transmission areas have their sunset at different times, the effect is spread out. What is then crucial is that the impact of such large and frequent ramps on the transmission system are carefully studied and coordinated between control areas.

Solar capacity factor is extremely low, around 23% on average in the United States. Solar daytime insolation levels can be depressed for prolonged periods of time spanning from hours to weeks. Figure 4-4 demonstrates these output levels and shows that, for example, PV produces 75% or more than its rated output for only 27% of annual daylight hours.

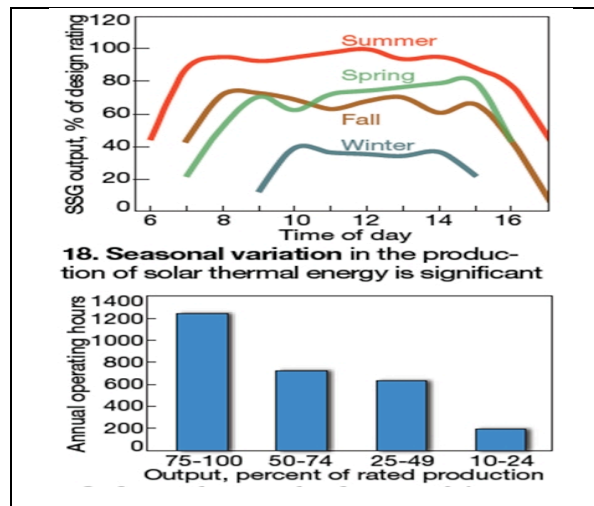

Figure 4-4. Solar Capacity [20].

This leaves enormous generation gaps to fill. Electric energy storage of this

magnitude is not available in any cost effective form to date. Increased pumped hydro-power capacity would require larger dams and generators to which may not be feasible given hydraulic considerations. The crucial question in the analysis of the impact of intermittent generation on power networks then is "Is generation capacity adequate to meet load when the intermittent resource has depressed output?". The next section will explore the phenomena that the peaking plants that are currently called upon to meet load in the times of peak demand, and that system planners are expecting to use for these troughs in solar output will be detrimentally impacted financially by the advent of increased solar and investment capital for these projects may dry up as a result.

## CHAPTER 5

### THE ECONOMIC IMPACTS OF INCREASED PV PENetration ON ENERGY AND RESERVE MARKETS

#### 5.1 Reserves for Renewables

A 2005 study on the integration of wind energy into the German electricity grid performed by the German Transmission authority DENA, assessed the requirements for additional reserve in capacities. The study found that fluctuations of wind energy mainly affect the demand for minute (a product which did not exist at the time of the study) and hourly reserve [21]. For the year 2003, the study calculated an additional average up-reserve demand of 8.1%, and down reserve of 5%, were need to meet the variations in wind output. This corresponds to an additional demand for minute reserve energy of ca. 2.1 TWh positive and 1.4 TWh negative minute reserve for a wind portfolio producing ca. 36.8 TWh of wind energy.

The cost of the required additional reserve can be estimated by multiplying the required capacity by the corresponding average capacity price of minute reserve. Based on the data provided by DENA, the cost of the additional reserve can be estimated to be between 150 and 200 million dollars for the year 2006. Extrapolating from those numbers we could expect scenarios with more than ten percent solar penetration to incur more than \$1 billion in reserve costs per

year. Similar to the costs projected in Germany, in order to achieve the state of California's ambitious RPS goal of 20% of power generated by renewables by 2020, the California Independent System Operator estimates it will need to increase the up and down-regulation by 50% [22]. Simulations of California grid show that in a scenario where 35% of the grid energy is produced by renewables, the combined cycle units are almost completely off, gas turbine output has increased, the coal plants and even the nuclear units are cycling significantly [23]. The operation of power plants in partial load mode reduces the efficiency and leads to higher generation cost and CO<sub>2</sub> emissions. This phenomenon occurs mainly due to the fact that the existing power plant portfolio is not optimized for the operation with increasing renewable electricity generation diurnal cycles.

## 5.2 PV Energy Market Participation

As we move to longer time scales we shift focus from regulation to understanding how PV impacts energy markets. PV plants and other renewable energy sources possess a strange characteristic from a market participation standpoint. Although their amortized cost of energy is much higher than that of traditional resources, renewables have no variable cost of production. Because PV plants are completely unmanned and have no moving parts, there is no



material cost difference between idling a plant and operating it at full output. Without costly storage devices PV plant operators must produce whatever they can at a given moment or lose it forever. PV plants are therefore “price takers,” i.e. they deliver power at whatever price the market will support. This inelastic supply has been witnessed in the markets with large wind power capacity, in instances where wind producers have entered negative offers, which they can bear due to production feed-in subsidies. These types of price signals are an unhealthy trend from a long-term planning and investment standpoint. The primary method of price discovery, SCOPF, relies upon convex cost curves to produce prices reflecting the mismatch between supply and demand. It cannot produce meaningful prices when infected by these types of aberrations.

The Merit Order Effect (MOE), put simply, is the substitution of renewable electricity for conventional generation in the merit order. The consequence is a lowering of the market price for electricity. Because the marginal cost of PV is zero, the lowest cost solution to the economic dispatch problem will always be the one that utilizes the maximum possible of the available solar power at a given hour which they can bear due to federal feed-in tariffs for power produced. In a bidding (or scheduling) process PV plants will enter very low offers to sell power, to ensure they are dispatched. The remaining generation that has to be purchased on the electricity markets by the utilities is reduced

correspondingly. As long as the total supply curve has a positive slope, the shift along the curve leads to lower prices. The effects of renewable electricity generation in a competitive market for a single hour is given in Figure 5-1, where it is assumed that the electricity demand is inelastic.

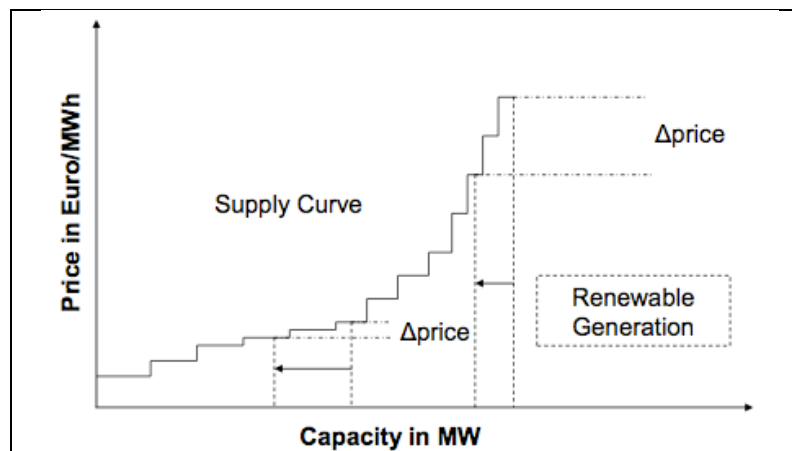

Figure 5-1. Merit Order Effect. Source: Sensfuß, 2007.

### 5.3 Studies on Price Impact of Renewables

For his 2007 doctoral thesis at the University of Karlsruhe, Frank Sensfuß ran fifty market simulations with and without supported renewable electricity generation for the year 2006 in order to assess the impact of renewable electricity generation on the profits of generation companies owning conventional power plants. The results indicate a considerable reduction of the average market price by 7.83 €/MWh in the year 2006. In total, the volume of the MOE reaches about €5 billion in the year 2006 [24]. The following Figure 5-2 shows two scenarios, one including and the other excluding renewables.

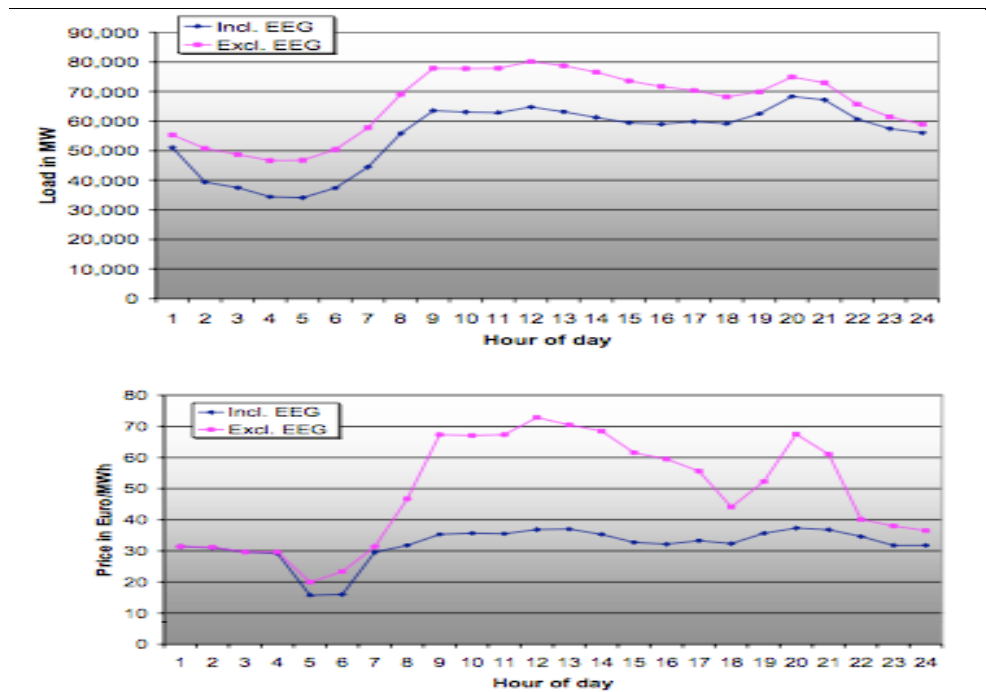

Figure 5-2. MOE Price Simulations. Source: Sensfuß, 2007.

Renewable generation in the selected period varies between 4.4 GW and 14.7 GW, but its impact on prices varies more. During hours of low load the reduction of the market price is negligible, while it reaches up to 36 €/MWh in hours of peak demand. This difference in the impact on market prices is caused by the different slopes of the German supply curve, which are higher in cases of high demand.

The results show, not surprisingly, that the MOE grows in line with renewable electricity generation. The analysis of the variation of the gas price shows the highest impact on the result. A reduction of natural gas prices by 20% leads to a reduction change of the MOE of ca. 30%. The disproportionately

high effect of a variation of the gas price on the volume of the MOE can be explained by the impact of the gas price on the generation cost. Since gas fired units set the prices in most hours of peak demand, the effect is not leveled out by scheduling another generation technology. Fuel prices for coal and nuclear have a very low impact on the value of the MOE as the base load power plants are rarely replaced by renewable electricity generation.

#### 5.4 Planned Capacity Investments

As solar power makes up a larger share of the generation portfolio, its presence will not only lower real time prices through the MOE, it will also direct revenue away from peaking units which operate within solar's maximum output period 10 AM - 5 PM. Natural gas generation in the United States, for instance, is 39% of capacity but only 23% of generation output, compared that to 10% and 20% for nuclear. Natural gas combined cycle units averaged about 40% capacity factors in 2007 [25].

Figure 5-3 shows a load duration curve which illustrates the power that the PJM ISO must be able to procure to meet load for different durations during the year.

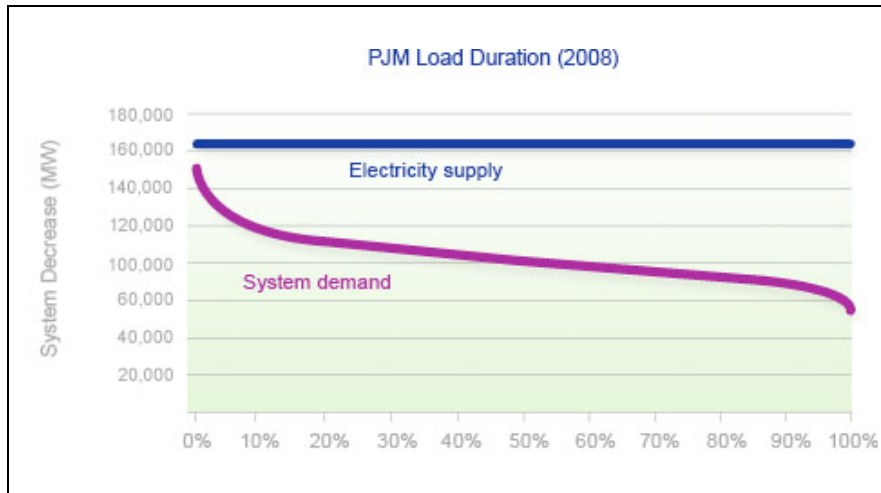

Figure 5-3. Load Duration Curve [26].

Less than 10 % of the time is more than 120,000 MW needed, and less than 3% of the time or just 260 hours a year are and additional 20,000 MW needed. ISOs' current rationale is to procure the maximum need at any point plus the largest single contingency. There are a variety technical approaches to determining the proper amount of reserves, like “The greater of 5% of the hydro-power plus 7% of all other resources plus 100% of interruptible imports or the single largest contingency,” [27]. How this translates to maintaining enough regulation and load following capacity to run the system with solar is an ongoing discussion. Solar produces less than 25% of its output only 5% of the time. The probability that solar is at its trough while demand is at a peak, and the consummate cost associated with adding additionally capacity need to be

determined. Determine the correct coefficient for solar in the previous equation is a calculation that can save or waste billions of dollars.

Solar poses a unique problem in that it reduces baseline capacity through MOE but needs a larger amount of back up as it is not secure, or firm. Peaking units operators, the most sensitive to operating time as their capacity factor is lowest, will see profits stagnate because their fixed costs remain constant yet their revenue dwindles. A quick calculation reveals the sensitivity of gas producer's return to the fraction of the grid powered by solar. Based on national average 5.5 sun hours per day every MW of installed PV capacity produces c.a. 2000 MWh per year. Assuming gas units only operate at the hours of highest solar output, then with current installed capacity of 4 GW, PV reduces revenues for gas producers nationwide by 8,000 GWh per year, or 8% of revenue, which has a much bigger impact on profit given low capacity factors. The Sensfuß study determined that the net financial impact on natural gas producers could be nearly \$5 billion per annum.

The upshot is that marginal producers will need to raise their prices to continue to earn the same return for their investment, but cannot because they are already the highest cost producers and are thus pushed out of the market. Owners of these units will not maintain them or invest in new units if the market is perverted and confusing. Additionally, if conventional generation units that

were previously expected to provide primary frequency control are de-committed as a result of the economic dispatch then the remaining frequency control reserves may no longer be adequate. For the remaining generators the cost increase may become too onerous and they may choose not to bid into the market. This is a dire situation for the future of PV and renewables. These units are critical for smoothing out the fluctuations in renewable power output and must be incentivized to participate in the market.

## CHAPTER 6

### AN ENERGY MARKET REDESIGN FOR MANAGING VARIABLE RESOURCES

#### 6.1 Redesigning the Electricity Market

As we have seen, there are substantial costs associated with a business-as-usual approach to handling PV intermittency. ISOs must procure additional capacity, power plants must supply more regulation work and in conflict with both of these goals RTMPs will be reduced by the MOE discouraging investment in natural gas units. This thesis proposes to address this dilemma by reconfiguring the electricity market pricing structure to translate all power imbalances into real-time market price signals, in order to more accurately determine the instantaneous value of energy. This would allow energy markets to naturally reward participants who can quickly respond to frequency fluctuations. Conversely, for participants such as SPPs who cannot control the specified time of delivery of electricity, their product is discounted. By utilizing markets to monetize the risk associated with intermittency the true cost of reliability is determined, rather than mandating ad hoc capacity figures and rewarding idle plants through capacity payments or reserve markets. A more flexible market would encourage all suppliers,



loads and generators, to offer supply or reduce consumption when it is needed most.

Traditionally power system operators have viewed the load as an uncontrollable variable that is a firm command to be met by generation and is only to be curtailed under severe stability conditions. 2002 Nobel laureate, Vernon Smith, bemoans this supply side attitude, “Eighty-five years of regulatory efforts have focused exclusively on supply, leaving on dusty shelves proposals to empower consumer demand, to help stabilize electric systems while creating a more flexible economic environment,” [28]. Perhaps *the* emerging concept behind the Smart Grid is enabling customers to become active participants in electricity markets by responding to the real time conditions of the grid. This new emerging entity is no longer just a consumer, and has been branded as the “Prosumer,” an economically motivated entity that, optimizes the economic decisions regarding its energy utilization. The smart grid is then the necessary extension, i.e. a network of Prosumers [29].

Today, distributed energy sources, energy storage, enhanced device control and computational techniques are emerging to allow the Prosumer to reduce energy costs by deferring consumption during the intervals when prices are high. Customers who are willing to curtail

consumption when spot prices are high are essentially providing a regulation service to the power system. This way both the consumer and the utility can benefit by reducing capacity costs for extra regulation, which in turn lowers energy prices. Approaches such as Advanced Load Response (ALR) and Distributed Dispatchable Generation (DDG) are particularly advantageous for replacing traditional capacity because they involve configuring or retrofitting existing facilities and not major investments in new equipment, and reduce energy consumption.

## 6.2 Advanced Load Response

Here we will classify load response programs under two main categories, Load Frequency Regulation (LFR), an instantaneous but brief customer response to frequency deviations and Advanced Load Scheduling (ALS), a customer-side algorithm scheduling loads over minutes to hours to benefit from price fluctuations. Nearly every consumer load involving temperature control could be used in a LFR scheme, where power consumption is linearly modulated based upon frequency error. This would effectively increase the damping torque seen by synchronous generators. For example, hot water heaters, could be cycled on and off several times over the course of a minute without

impacting the residual water temperature. While the cost benefit ratio of this type of technology is extremely favorable, there is not currently any incentive mechanism for large scale deployment on the customer side. If prices could respond in real-time to frequency deviations then these techniques would benefit the owner.

A customer can defer his load in order to procure a benefit but demand becomes increasingly more inelastic over time. In 2008, FERC estimated 4.7% of the U.S. customers had advanced meters, but these are mostly used as a day versus night programs, if at all [30]. It is paramount for ALS deployment then, that customers see future prices, so they can alter their current behavior in anticipation of price movements and contribute to grid resiliency. ALS software has been developed by industry to help customers schedule loads based upon expected prices. These products could spark widespread and constant use of demand response, which totaled 5.8% of peak demand in 2008 (40,000 MW), or more than 10 times the installed solar capacity, directly involved in grid regulation and not only in emergency situations [31]. However, the feasibility of supplying real-time and future prices to millions of users lack is in part due to the technological hurdles which will be addressed.

### 6.3 Distributed Dispatchable Generation

Rather than maintaining peaking units that are under-dispatched, the proposed market architecture will enable the enormous quantity of generation already exists in the forms of customer owned generation to become active producers in the energy market. Differing drastically from the aforementioned cases of loads that may be deferred or interrupted, many of a utility's largest loads require uninterrupted power supplies, because of the critical nature of their processes. Hospitals, airports, data centers, and military installations have invested hundreds of millions of dollars in redundant generators that will keep systems operational for as long as the outage. It is estimated that there are approximately 12 million backup units in the US with 200 GW of capacity [32].

An example of integration of these resources into a dispatch structure is Portland General Electric's Dispatchable Standby Generation program. Recognizing that backup generators mostly sit idle and constantly generate stream of operating and maintenance expenses, PGE initiated the program, whereby customers rent their standby generators to the utility for 200 hours a year to cushion the utility against the sharp spikes in wholesale power prices. PGE pays for enhanced generator controls as well as offers free generator maintenance services for

customers. From a central dispatch center PGE can monitor, start, stop and check maintenance statistics on the distributed generators. As of 2011, the program counts on 80 MW and growing on a 4 GW peak grid. The cost to the utility to procure emergency capacity through this program is about half of what it must pay for new build outs [33].

As a consequence of the second law of thermodynamics, thermally fueled power generation loses 60-70% of the energy content of the fuel as waste heat into the environment. If electric power is generated at the location of the load, the waste heat from the thermal cycle can be utilized for air, water or process heating, granting a 30% improvement over conventional power plant efficiency and resulting in a total system efficiency of nearly 80%. This process is known as Combined Heat and Power or CHP. Additional system losses in the transmission and distribution networks around 10% are saved. About 40-50 GW of CHP generation are in operation in the U.S as of 2000 [34]. While CHP accounts for only 7 percent of electricity generation in the U.S., it powers nearly 60 percent in Denmark, which has embraced small CHP as the most cost effective method of energy management [35].

A major advantage of CHP is that, based on the next day's cost of power or weather forecast, an Energy Management System may choose

to have utility or onsite power used at night to "charge" a thermal energy storage tank. During times of peak prices, the EMS can dispatch the thermal energy storage to shift peak loads. This is an excellent compliment to the volatility of solar. Like ALS technologies, in order to optimize its schedule Prosumer generation will prices with higher time resolution and to know how long prices spikes will last, as startup costs may be higher than profit for brief spikes.

#### 6.4 Motivation for a New Market

Regulation reserves are currently needed to compliment energy markets because generating units do not respond to energy prices (nor are prices are not updated) quickly enough to maintain grid stability. Frequency excursions are typically brief, and have too little energy content to generate strong energy market signals to motivate rapid response. Even \$1000/MWh only amounts to \$16/MW each minute and only \$0.28/MW each second. Because of this limitation primary frequency regulation is required to be an automatic response to frequency, and is not connected to prices.

These modes of operation are based upon the legacy of large thermal plants, which are inherently slow moving and cannot be brought

online from a cold start quickly. Therefore regulation is procured as a separate service and does not impact RTMP. Additionally, most of the power in the grid is bought and sold through bilateral forward contracts, and is not impacted by RTMP. On the customer side, load response programs are limited to an on/off decision taken by the utility according to a bilateral contract with the customer. Time of use billing is night versus day, and very few customers currently receive real-time prices.

With the exception of LFR, the Prosumer technologies identified in this thesis all share the need to see or commit to future energy prices to schedule their load, generation and thermal needs. On the other hand, PV output cannot be regulated and predictions of output from PV systems with a large time gap have a unmanageably large error. Power systems require a higher degree of dependability than PV can provide, markets need accountability for energy forecasts and Prosumers need forward prices. We have identified three requirements: 1) Prices must be fast are able to bring power online quickly enough for grid support. 2) Prices must fluctuate enough to activate these units and reimburse their additional cost to encourage investment and research in competing technologies. 3) Short term prices are need for Prosumer scheduling. How can we configure the market so that decentralized power generation, digital load

intelligence, and intermittent renewable resources work together under a common infrastructure so that their strengths and weaknesses can compliment each other?

### 6.5 Forward Market

A new method of determining and disseminating prices is called for that is massively parallel, redundant, offers a common infrastructure with interoperability throughout like the Internet. The keystone idea to fully integrating PV into this new blended energy and ancillary services market is to create a short term futures market with a 10 minute delivery window to enable fluctuating demand and solar power to be controlled by Prosumer scheduling algorithms. ALS and DDG will look ahead to future prices and lock in respective troughs and spikes in prices. SPPs are treated as special cases of Prosumers who cannot control their output, but participate in this market to provide power systems the necessary advance price signals to smooth fluctuations.

Prices are updated to reflect the real-time needs of the grid and the speed of the proposed price update will replace both primary and secondary regulation. In order to do so the notion of an operating hour needs to be replaced by the notion of an operating minute so that grid



each participant's response to the grid is that much more finely tuned to grid fluctuations. In the age of ubiquitous computer control this is really not a challenge. These price signals are a natural extension of the concept of LMPs. Now, no longer are only geographical constraints considered but temporal aspect as well. Temporal Locational Marginal Prices include the value of the next MW-minute hour added, at this moment in time.

Figure 6-1 depicts the a forward market with minute-ahead prices. The vertical lines each represent a forward operating minute. The green horizontal lines are the cleared price as of the current operating time and the blue line is the RTMP price that the market found in the simulation. The pink dashed lines represents a marginal cost of utility for a Prosumer. This is the price that a market must exceed (or be below) for the Prosumer to activate a device. The area between this line and the green lines represents the amount of revenue that a Prosumer obtained by locking in the forward prices at the five minute mark. In both cases, the Prosumer would have been more profitable to operate at RTMP, but given other realities it may be necessary to schedule the device.

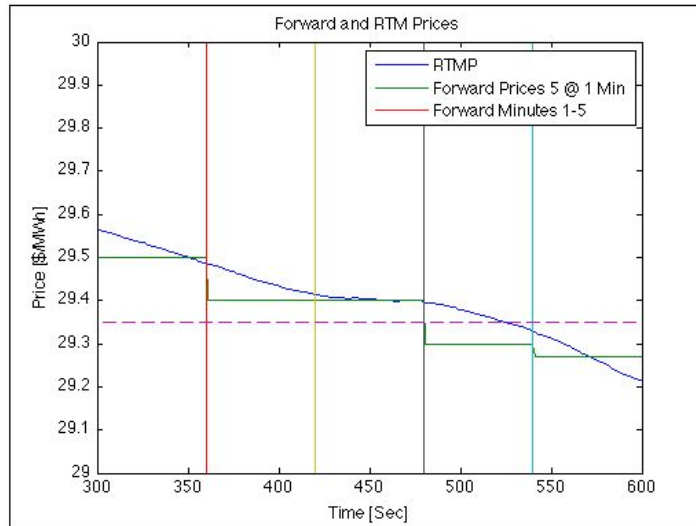

Figure 6-1. Forward Prices.

If a consumer sees a high price, but is not informed when prices will come down, he is less likely to reduce consumption, because as far as he knows future prices will not be any better, so he has no reason to forgo current consumption. As prices continue to increase they surpass the marginal utility of individual customers and they stop purchasing power. Likewise, below a certain price marginal demand drops to zero and customers do not consume any more power, no matter what the price. At these points the market is "sticky", i.e. not self correcting. By introducing forward markets this inelasticity region is reduced. Consumers consume less at high prices because they are aware that prices will spike and therefore take advantage of the opportunity. Similarly they reduce their consumption more when prices are high because they see it coming down.

An important phenomena for getting consumers into the market is to find the optimal region in the demand curve for the maximum elasticity of demand. In Figure 6-2 consumer elasticity for both market is depicted for prices \$10-20/MWh.

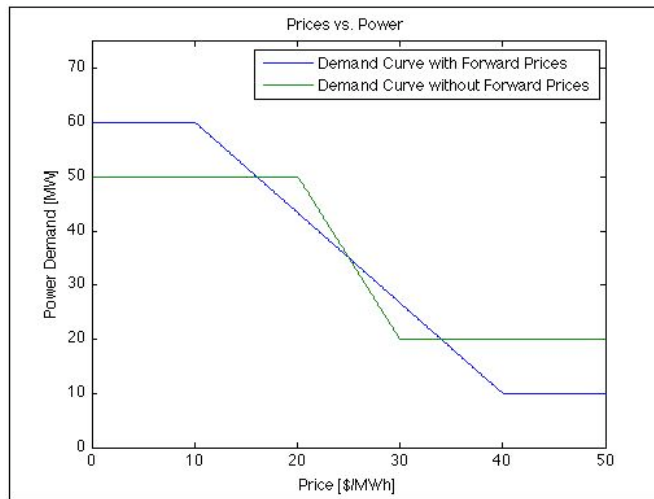

Figure 6-2. Demand Elasticity Prices.

## CHAPTER 7

### MECHANISMS FOR IMPLEMENTING MARKET REDESIGN

#### 7.1 New Price Dissemination Scheme

Here we introduce a new method for price calculation and dissemination that meets the previously defined criteria to support the new architecture. The central operator is the Bus, which we define as an interaction between two differing supply curves, i.e. a node where a common price for power needs to be discovered. and Because we wish to explore the concept of a Smart Grid with a network of Prosumers, we consider that all consumers can produce power or reduce consumption, and therefore create an individual supply/demand-reduction curve. In that way it is a highly adaptable, flexible, scalable concept. Each PV unit and Prosumer is connected to the Bus, via a power plus communication line. The Bus's task is to protect the thermal and security limits of devices to which it is connected by producing a local price for the connected resources. Based upon the resources' submitted supply curves this price then correlates to a specified net power output. The price calculation algorithm is based upon the price of power at adjoining Buses as well as grid frequency. Collectively, the local control decisions made by

the resources have the same effect as the centralized control strategy and converge to the same LMPs as an SCOPF.

## 7.2 Bus Price Dispatch Algorithm

Each Bus has the following pieces of information:

- a) Supply/demand-reduction curves from the customers connected at that Bus. This can be facilitated for customers by an EMS software with a few simple preference settings. The customers are expected to adhere to these curves for the length of their validity which is 30 minutes or incur penalties.
- b) Vectors of security constrained limits and PTDFs of connected transmission lines {See Appendix A for how these are obtained}.
- c) Power flow measurements of the transmission lines connecting the Bus to other Buses.
- d) The current prices from the neighboring Buses it is connected to.
- e) System frequency.
- f) A predetermined "Power-Step",  $\Delta P_{\min}$ .

## 7.3 Price Updates

At every time step the Buses share price information and post

updated prices. The inputs to the price update algorithm are the current neighbors' prices, power line flows and security constrained limits, and system frequency.

Steps:

(1) A vector of the available transmission capacity (= security constrained limits - present current flow) for all neighboring buses is calculated. Power flow measurements of the transmission lines connecting the bus to other buses.

(2) List Neighbors in order of prices, then picking each neighbor starting with the most expensive:

i) Is transmission capacity of this line  $> \Delta P_{\min}$ ? If No, then move to next neighbor.

ii) Is neighbors price = bus price? If Yes, then move to next neighbor.

iii) If neighbor's price  $>$  Bus price and power flow  $< 0$  then lower price by  $\Delta P_{\min} * \Delta \text{Price}$  and vice versa for neighbor's price  $<$  Bus price and power flow  $> 0$ .

iv) If neighbor's price  $>$  Bus price and power flow  $> 0$  or v.v.

then check:  $\Delta P_{\min} * \Delta \text{Price} * \text{PTDF Vector} < \min(\text{Transmission Capacity Vector})$ .

v) Transmission capacity vector is updated by the amount  $\Delta P_{\min}$   
 $\Delta P_{\min} = \Delta P_{\text{Price}} \cdot \text{PTDF Vector}$ . The algorithm moves to the next most  
expensive bus and runs through the same process. These power  
changes are all added together and constitute the 'Price-Power'  
Step,  $\Delta P_{\$}$ .

(3) The Bus is programmed with a PI control to regulate frequency. The  
PI output determines a fraction of power increase/decrease in response  
to frequency changes. Because the final component is added to the  
previous price this particular regulator is in fact a PD control. Upon  
integration it becomes a PI. This determines the 'Frequency-Power' Step,  
 $\Delta P_{\omega}$ .

(4) 'Price-Power' Step and 'Frequency-Power' Step are summed together.  
 $\Delta P_{\text{Tot}} = \Delta P_{\$} + \Delta P_{\omega}$ . The Bus consults its supply curve to determine the Price  
Step, given the Power Step, and publishes the new price.

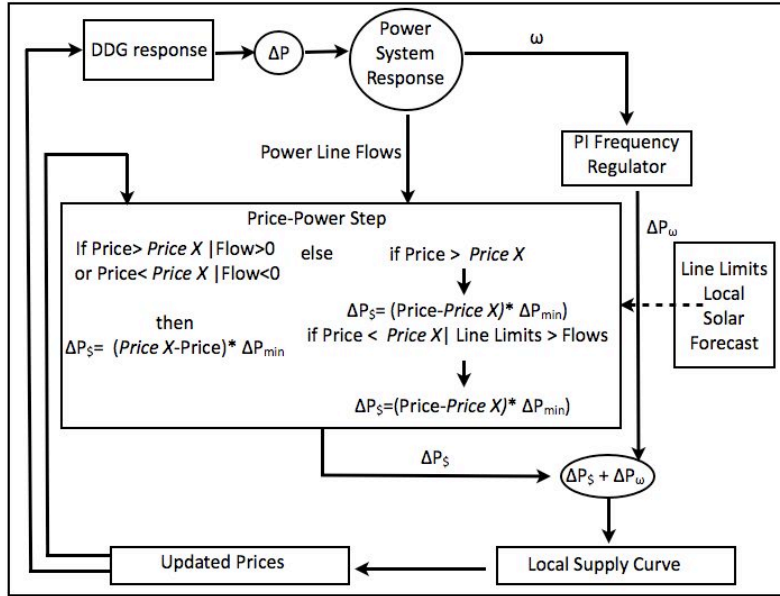

Figure 7-1. Price Update Algorithm Flow Chart.

#### 7.4 Remarks on Algorithm

Because adjacent Buses are not aware of each other's supply curves, the algorithm must ensure that Buses add or remove the same amount of power from the system upon a price step (power transfer), in order that undesired frequency deviations do not occur. Therefore, when a Bus takes a price step, the final PowerStep must be a multiple of  $\Delta P_{min}$ . That multiple is shared with the adjoining Bus and is the price difference.

In steps 2.iii and 3 it is not necessary to consider the transmission capacity of a Bus's lines before the PowerStep. In the first case, the power transfer is from a receiving end to a sending end so the flow is reduced. In the second case, this is a system wide frequency regulation, and each bus adjust by the same  $\Delta P_{\omega}$  so flows do not change as a result.



In order to show that when Bus dispatch algorithm converges upon a solution it is an optimal dispatch we can use the following heuristic argument. If it were not optimal there would be a Bus whose price is higher and one which is lower than the optimal prices, and there would be a feasible power transfer between the two which would lower the system cost. Therefore, there would exist a transmission line in which power flow could be increased where the price at the sending end is lower than the receiving end. However, when the algorithm converges, for every line where the power can be increased the price on each side is the same and for lines with price differences the power cannot be increased.

### 7.5 Prosumer Futures Market Mechanism

Buses will run a day-ahead and hour ahead market closings based upon predicted load minus forecasted solar production to allow long ramp time thermal plants to prepare for the day ahead. The aim of this closing is to limit the amount of relatively expensive power that must be procured/deferred by Prosumers. At this point there are no Prosumer obligations. They may purchase power in this closing but are not required to.

We would like to make maximum use of the speed and flexibility of the Bus Dispatch Algorithm and use it to produce prices for ten forward

minutes and an additional 60 forward seconds directly following the operating time. Thus, each operating seconds less than 60 seconds away from the operating moment will have its own forward price. We continue the focus on smaller time window and specify this quantity of energy as the megawatt-second. This facilitates a smoother convergence to the RTMP and more accurately responds to solar's variations.

(1) At 10 minutes before the OM, SPPs submit their predicted output to the Bus. Using current power consumption as demand, the Bus determines the intersection on the Prosumer total supply/negative-demand curve and fixes a price for power for ten forward minutes. This price is then published to Prosumers who purchase contracts to supply or reduce power at the forward OM. These actions alter the original price, which is now fixed. SPPs then enter into futures contracts to sell their predicted output power to the Bus at this revised price.

(2) As the OM approaches, updated solar and Prosumer loads forecasts will constantly reflect more accurate OM conditions. Prosumers will adjust their positions by buying or selling these futures to more closely resemble their forecasted net usage. If there is more solar predicted to be available

SPPs will look to sell this extra power,  $\Delta p$ , and will enter into future contracts with a delivery time of the remaining time until the OM.

(3) For the forward minute one minute after OM the Bus specifies a price for each operating second. The Bus take the value of the previous contract and divides it evenly over the minute for and average output per operating second (OS).

(4) In order to anticipate the needs of the next OS the forward MW-seconds prices are incorporated into the Buses' Price Update function. This is a feed-forward mechanism, which can greatly reduce variance in frequency by adding the "Future-Power"Step to the total power step,

$$\Delta P_{Tot} = \Delta P_{\$} + \Delta P_{\omega} + \Delta P_{Future}$$

As a method to encourage participation in the market overproduction or (under-consumption for Prosumer-loads) is treated like in the Spanish wind market or ERCOT where power above the forecast is penalized by sliding proportion, but only if the frequency is above 60 Hz.

$$Revenue = \$_{Forward} \cdot P_{Forward} + \Delta_{Error} \cdot RTMP \cdot [1 - \frac{\Delta_{Error}}{P_{Forward}}] \text{ (if } \omega > 60 \text{ Hz).}$$

## CHAPTER 8

### SIMULATIONS WITH NEW MARKET PROTOCOLS

#### 8.1 Bus Algorithm Simulations

In the following we will apply the bus dispatch algorithm to a power system consisting of six buses, configured as seen in Figure 8-1. Bus 1 is a natural gas fired generator, Buses 2 through 5 each have 100 MW of fixed load and 20 MW of solar power. Bus 6 is a coal fired power plant. The solar plants use real one second irradiance data from 4 National Renewable Energy Laboratory pyranometers located at separate sites on the Hawaiian Island of Honolulu and average distance between sites is 10.5 miles [36]. Security constrained line limits are 250 MW and the system has a total inertia constant of  $M = 10$  sec.

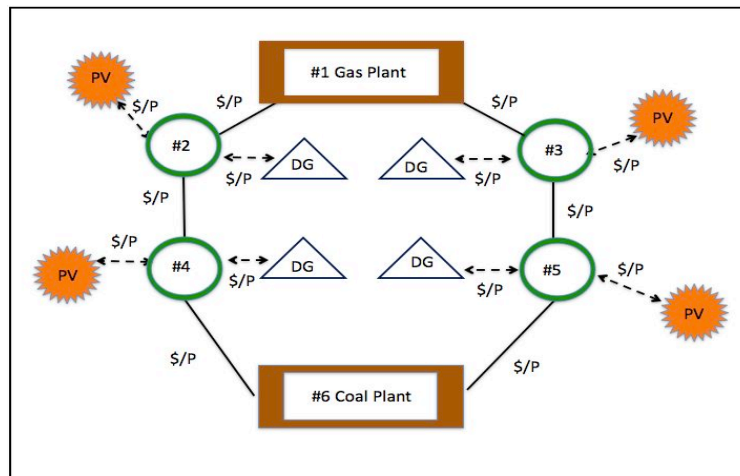

Figure 8-1. Simulation Configuration.

The price curves for the coal, gas and Prosumer are shown below in

Figure 8-2. The black horizontal line represents the price for a dispatch that is completely supplied by the coal plant. The colored lines represent a dispatch that must be redistributed to account for a limit on the power lines from Bus 5 to Bus 6. Price curves are approximated by logarithmic functions,  $A \cdot \ln(\text{Price} - C)$ . The coal, gas, and Prosumer coefficients are found in the following table.

Table 2. Cost Curve Coefficients.

Source/Coefficient	A	B
Coal	60	15
Gas	40	20
Prosumer	20	25

Solar power is not included at the Buses in the first two simulations, and demand is kept constant.

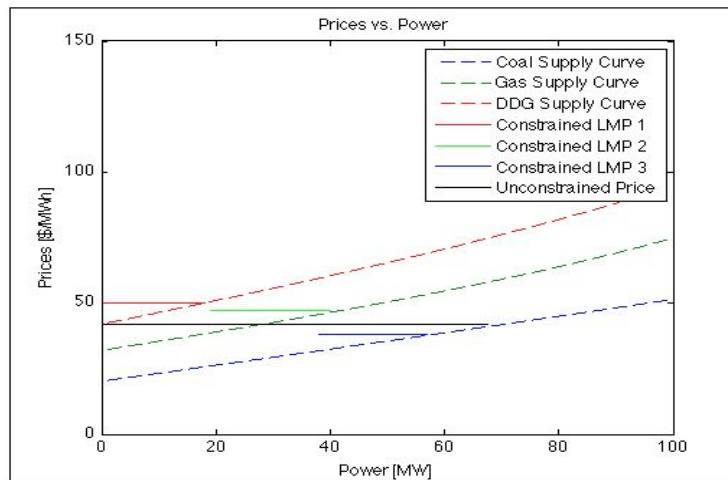

Figure 8-2. Price Curves and Prices.

Simulations are performed running a routine in Matlab that updates prices each second. The MATPOWER suite is utilized to determine the power flows [37]. Bus number 1 is treated as a slack bus, given its prescribed function as a natural gas generator. The difference between the command power and the slack bus results are used to determine the change in frequency for each second.

In simulation 1 the buses are given random prices and Figure 8-3 shows their convergence to the price of the coal bus because there are no transmission limits.

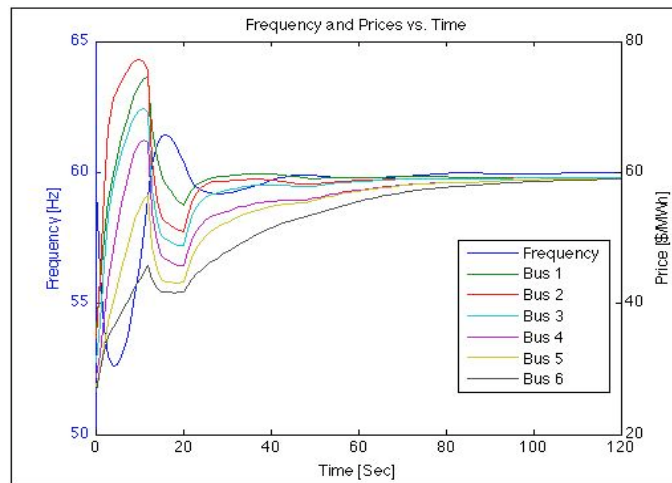

Figure 8-3. Price Convergence Simulation.

In simulation 2 prices are converging when the buses receive updated security constrained limits of 60 MW for lines # 5 and #6 at time = 75 seconds. Then prices diverge and find a new equilibrium. Notice the

inflection in Bus #6's price trajectory, as it can no longer increase its price to match Buses #5 and #4.

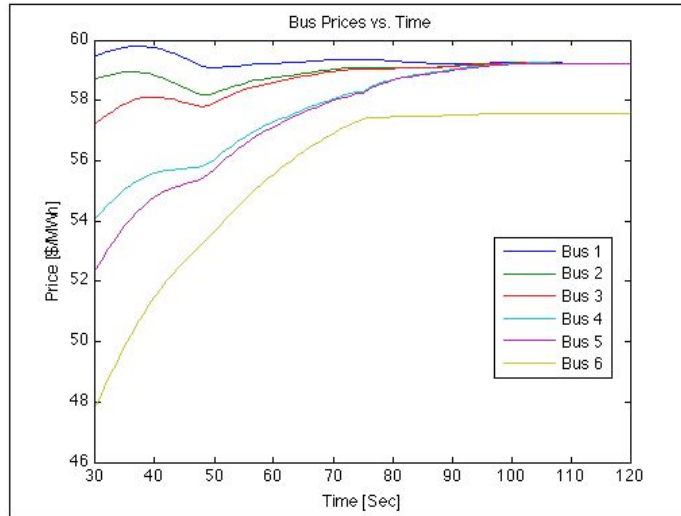

Figure 8-4. Price Convergence Simulation with SCL Change.

## 8.2 Simulations with Solar Data

A spring morning over a one hour period from 7 AM to 10 AM is chosen. The following matrix relates the correlation of solar insolation for sites to each other. The diagonal contains information on the variance of the individual data set.

Table 3. Raw Solar Data Correlations.

	1	2	3	4	Total
1	$\sigma^2=0.34$	0.9243	0.4834	0.3706	0.8675
2	0.9243	$\sigma^2=0.37$	0.5680	0.4133	0.9070
3	0.4834	0.5680	$\sigma^2=0.36$	0.4533	0.7733
4	0.3706	0.4133	0.4533	$\sigma^2=0.41$	0.6803
Total	0.8675	0.9070	0.7733	0.6803	$\sigma^2=0.33$

In simulation 3 we wish to set a bench mark for comparison by using a PI controller feeding regulation signals to the slack bus to simulate a centralized primary and secondary regulation control strategy against the bus dispatch scheme. The prices at the Buses are not altered and therefore neither is their output. Then the simulation is run with the same solar data using the Bus control scheme. For both instances the amount of regulation necessary to stabilize the system is recorded. Figure 8-5 depicts simulation 3's frequency and price responses using the Bus regulation strategy.



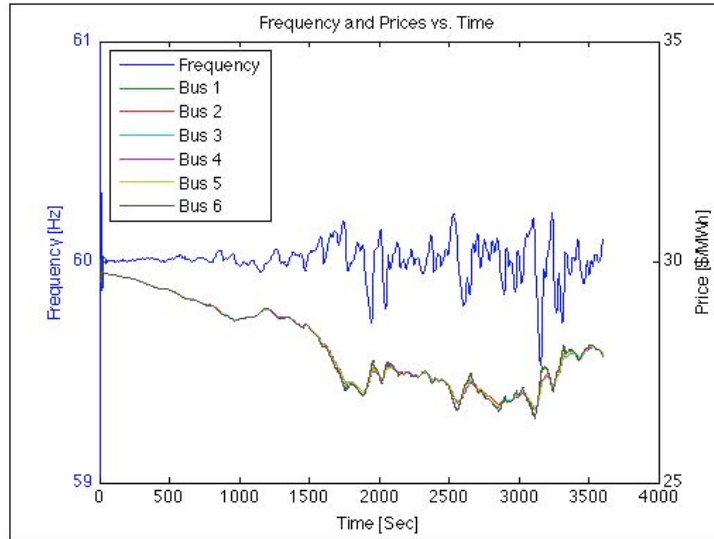

Figure 8-5. Simulation 3.

In simulation 5, the previously described conditions are applied to a power system with a forward market, which is simulated by using a simple function to determine the next most likely solar output and passing that to the price update function.

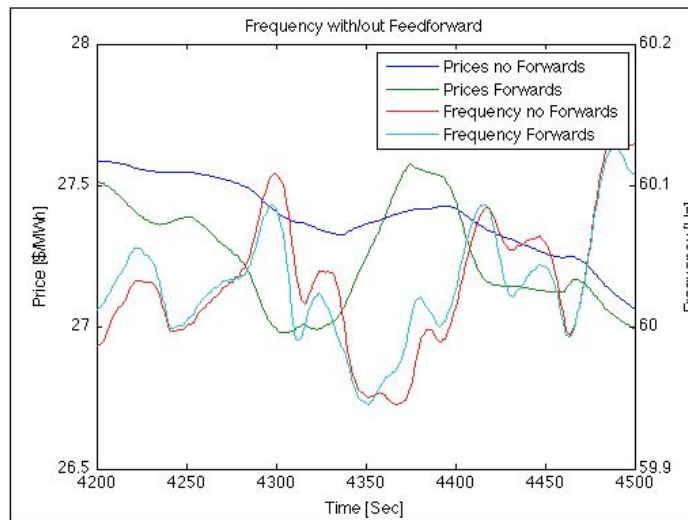

Figure 8-6. Simulation 5.

In Figure 8-6 the difference in the price movements is very obvious. The green line shows the price with the forwards market. Around the 4275th second there is a drop in price where the system anticipates the next moments solar insolation spike and accordingly adjusts the price. The reverse effect is seen then at the 4350 through 4440 seconds.

### 8.3 Results

Table 4 presents data from the full three hour simulations run with each control method. "Regulation" is the amount of power commanded by a control method to regulate frequency. The percentage of which is up-regulation is included in parenthesis. "Solar Price" is the average price that that solar receives for its power in these markets and is computed by:

$$\frac{\sum_{\text{sec}} \text{Output}(\text{sec}) \cdot \text{Price}(\text{sec})}{\sum_{\text{sec}} \text{Output}(\text{sec})}$$

"Negative Correlations" are the percentage of the time that prices and solar output changes are negatively correlated.

Table 4. Simulation Results.

<b>Data/Simulation</b>	<b>PI Control #3</b>	<b>Bus Price #4</b>	<b>Forwards #5</b>
$\omega$ max/min	66.54/60	61.61/58.75	61.51/58.75
$\omega$ variance	1.356	0.070	0.068
$\omega$ average	62.748	60.052	60.0472
Regulation [MWsec]	856 (47%)	3953 (10%)	6677 (6%)
Price max/min [\$]	30.8/30.8	21.92/30.8	21.94/30.8
Prices variance [\$]	NA	1.50	1.49
Prices average [\$]	\$30.45	\$26.07	\$26.05
Solar Price [\$]	\$30.45	\$25.63	\$25.60
Solar Revenue [\$]	\$55.65	\$46.31	\$46.23
Neg. Correlations	30%	44%	46%

## 8.4 Remarks

### General Results

The results show progressive improvement in frequency control using the Bus algorithm and forward market methods. The values in simulation 5 are approaching acceptable values for a power system yet they are still outside of previously mentioned operating ranges, particularly maximums and minimums. This can be attributed to the input data's variance, which is much higher than to be expected for a large power system and includes very large ramps. Actual performance would depend critically on the interconnected equipment and commensurate ramp times, delays, and dozens of parameters that were excluded from

this simple model. The aim of these simulations was to determine system response to quickly varying insolation, so the data was not altered.

Frequency improvements came at a staggering cost in terms of total or absolute regulation power which increased 460 and 780% over the PI control. There are three reasons for this. First, this is actually the realm of acceptable frequency control and it does come at an increasing cost in terms of regulation. Second, in the Bus dispatch scheme the regulation is now spread over the entire power system so the impact on individual units is drastically reduced and cycling costs become minimal, whereas in the PI case the regulation is all taken up by one Bus. Third, when comparing the amount of up energy these numbers are almost identical, signify the same amount of work energy is utilized. Because the time under consideration is a morning and solar power is increasing the most regulation steps should be down, given flat demand. The Bus algorithms use of energy is therefore more accurate, and efficient, while the PI steps are more haphazard.

### Solar Discount

As desired, the market has discounted the value of solar energy due to its undispachable nature. Using the original price curves and subtracting the average solar output over the course of the simulation a

price of \$30.45/MWh for energy is found and is not changed during the PI control simulation. However, in the Bus control simulations, SPP revenue is altered by real time prices. Average prices of \$25.63/MWh and \$25.60/MWh are found for the two simulation excluding the deviation from the predicted output. This reduction of 16% reflects how solar's inability to control its output, combined with the market's fast price updates determine a more realistic value of the solar power.

### Negative Correlations

Like solar plants with low geographic correlations, most loads are uncorrelated on small time scales. There are correlations related to time of day, year, and temperature, and human activity but these are predictable and operators do not have to contend with large unexpected jumps. When solar production and demand both conspire to change in opposite directions, regulation work must increase. What this approach accomplishes is to make these two stochastic variables negatively correlated by using future information in feed forward to regulate frequency. As can be seen in the row titled "Neg Correlations" the negative correlations between a price and a solar output increase when the Bus algorithm is used. The baseline performance is a PI controller which is acting against power ramps. In the first simulation the solar

power increased 30% of the time when price decreased and vice versa. In the following simulations this number increased to 44 and 46%.

### Superior Performance of Bus Algorithm

The most unexpected result was that major frequency and price improvements did not continue after the forward market was introduced. This can be attributed to the high correlation coefficients of the solar input data. As insolation changes and impacts system frequency, each bus responds to it. Thus, a weather system that is approaching the area doesn't have to reach each asset before its presence is already felt in the system and prices are readjusted. Most the information is already dissemination through network by the price update algorithm itself, making the improvement using the forward market less stark.

## CHAPTER 9

### CONCLUSIONS

The market modifications presented here constitute a fundamental shift in approach to controlling power systems. To use prices as *the* command to both generation and load simplifies control and market operations. For instance, whenever a system operator calls for the deployment of regulating generation there is a chance that the resource will fail to do so. Grid frequency continues to drop while the central dispatch senses the generator failure, calculates a new setpoint, verifies transmission capacity, sends it to another unit and waits for response. Because events such as these are represented as price signals in the new architecture, the instantaneous needs of the grid are communicated rapidly through the system so that individual units can act immediately rather than relying upon and waiting for decisions from a central processor that may not have complete or correct information.

#### 9.1 Benefits

##### Algorithm

In order for demand response and customer owned generation to replace traditional supply-side controls for frequency regulation hundreds of thousands of units will need to be involved. Additionally, each of these users needs to have information and authority to make dispatch decisions and prices will need to be produced on the order of seconds, not minutes as is currently performed. A centralized control strategy which issues a command to each individual distributed resource has very serious questions of cost and speed.

The SCOPF minimization problem becomes more complex the larger the control area becomes and the more units are involved. Midwest-ISO states that its entire EMS model covers 21,369 stations, 32,550 buses, 94,800 analog telemetry points that are refreshed every 4-30 seconds, 10,296 thermal facilities and 7,931 bus voltages with 6,920 contingency simulations executed approximately every 3 minutes [38]. If one 50 MW plant were replaced with 5000 10 kW units, the SCOPF run time would increase at by that same ratio, if it were to be considered to increase linearly. With the addition of a futures market there is far too much information for a centralized controller to process the millions of small decisions in such a short time period. It constitutes a serial bottleneck and cannot support an ever expanding platform.



By removing the bottleneck, the Bus dispatch algorithm is able to take into account the medium voltage distribution system, which previously has been untreated due to the unrealistic computational and monitoring costs. The vast improvement of the Bus algorithm's response to frequency changes via the price communication method for weather systems with high correlations was noted. At this level, a centralized controller could miss the geographic nature of the frequency imbalances. If, for example, the west side of a city has a major event meteorological compared to the east side, the west side's prices should respond accordingly for faster response and to respect transmission limits.

A distributed solution could rely on inexpensive and simple communication protocols such as the existing wireless metering network or power line communications that would provide the required local exchange of information for the distributed control approach to work. Additionally, frequency is instantly available everywhere within an interconnection without the need for additional communications.

### Distributed Generation

Utilizing distributed generation presents many advantages to centralized power plants. Employing more distributed generation would facilitate higher generator efficiency through increased fixed-power

loading for large thermal generators, lower headroom requirements and less transmission losses. When a greater number of generating units are used to deliver a small portion of the total regulation faster delivery of primary frequency control will result. Distributed generation can aid in local reactive power production which improves power transmission limits, resistive losses, and voltage stability. The environmental benefits come in tandem with financial savings and are increased generator and transmission efficiency, replacement of coal by natural gas, and full heat content utilization via CHP.

## 9.2 Impact on Electricity Markets

### Retail and Prosumer Competition

The new market redesign will have several major impacts on the way consumers, generators and retailers interact. Traditional utility load control programs provide no incentive to optimize performance. Customers are paid a flat fee or given a reduced energy rate independent of how their resource is actually used. They must agree up-front to be subject to utility control, and there is no ability to enter or leave the market as economic conditions change. But customers' desires are often at odds with the utilities' and the timing of customer owned generator

dispatch could depend on local electrical power, thermal, reliability, or power quality needs. If the energy market is structured to incentivize investment in these technologies by rewarding them with through energy price fluctuations the customer will see a return on these added costs, utilities would benefit from reliability and reduced losses, and society from less pollution and over investment in generations and transmission.

This competition functions could be automated and performed for Prosumer through the Bus by a Prosumer pool operator could coordinate buying and selling for a large group of Prosumers to maximize their profit and group PV resources into a diversified units. This would replace current retailers, who make bulk power purchases for weeks and months by entering into future contracts with large generators, acting essentially like insurance pools for customers in energy markets. This could significantly increase the amount of competition for retailers who can optimize their customers resources and through purchasing and selling and lower their electric bill. The grid and energy markets would benefit enormously from Prosumers competing against each other, which will in turn find the lowest cost solution.

### Generation Capacity

As of August 2011, utilities nationwide are running advertisements and calling customers at home to persuade them to reduce energy usage during a heat wave for fear that demand will exceed network capacity. Capacity problems are a growing concern with the decommissioning of tens of Gigawatts coal plants on horizon, which solar will exacerbate. Most important to the continued growth of solar is the introduction of a correctly structured energy market that can deliver economically optimal capacity payments to and encourage the correct amount of strategic generation.

As seen in Chapters 4 and 5, prices will fall on days with high solar output due to the MOE. In the new market, customers, particularly industrial customers, will consume more energy on these days mitigating price dips. On the flip side, the market will transition to having higher prices on those days without much sunshine, which can compensate generators for low daily prices and less operating hours. In order for generators which have been edged out of the market due to MOE to receive higher prices, supply should low at possible. Removing capacity payments and the reserve market which will limit conventional power plant build outs, and reduce the number of plants with low capacity factors.

The market alterations reduce required capacity in two ways. First, the maximum generation needed is reduced by Prosumer demand response so ISO no longer need to procure the last 10,000 MW that are only used for 100 hrs a year. Second, Prosumers provide capacity that does not require economic support because owners have already decided purchase it as backup. Prosumers are only rewarded by "regulation payments" in the 10 minute market where the most expensive generation responds to deep drops in solar production by entering into power delivery contracts. Prosumer demand responds by selling consumption reductions to the market for a price step below. The residual is what the generator makes for regulation payment. It functions like a reserve market but only procuring exactly the right quantity, and rewarding the correct price.

### Solar

An integral part of the solution that has been argued here is to give power producer a more exact value for the energy they produce, given the conditions of the grid and the producers' ability to commit to a production schedule. Accordingly, we have shown that the value of solar in the simulations has decreased from the marginal cost of the supply curve by 16%. By ascribing a diminished value to solar, it will put more

pressure on the industry to continue to drive down costs. Solar manufacturers should not be satisfied upon reaching prices of \$1/W as this milestone does not take into account the system wide costs of regulating and supporting solar output. System operators can mitigate this diminished revenue by investing in equipment such as PV inverters with a small amount of storage to aid in fast frequency regulation or reactive power injections to procure added revenue in the new market. The aim is not to try to discourage PV production but to set realistic goals for price relative to services rendered.

### 9.3 Areas for Future Studies

The treatment of transmission constraints, price curves, and ramp rates in the simulations was trivial. Likewise, voltage and reactive power flows were ignored. In addition to more detail, full scale simulations with thousands of buses need to be performed. Questions of stability and convergence associated with system symmetries emerge for large scale systems. For example, the algorithm will not converge to a low cost solution when there are symmetrical conditions present in the network. These may develop during real time operations and need to have an override mechanism. Another component that is interesting to explore is

the ability of the algorithm to respond to system faults and islanding. Because of its modular design the system has the ability to split into microgrids and self-regulate in the event of grid separation.

More work it still to be done to optimize the pricing structure. Two key areas are the forward market and regulation parameters. A forwards market that more closely models consumer load and generation scheduling combined with solar power fluctuations is needed. A major factor impacting the return for SPPs is the time at which they must make their first bid. Determining the optimal closing forward time for the Additionally, regulation controller gains could be improved upon by optimization methods, particularly if they change dynamically with the system. Both of these improvements require using the more detailed network simulation data to run sensitivity studies of the Prosumer market, accounting for solar variance, generation and load ramp rates, and consumer elasticity. Before such a market mechanism can deployed, in-depth simulations of the expected impacts on costs and revenues for the participants need to be studied to prevent undesired results or undermine government support programs.

## APPENDIX A

### SECURITY CONSTRAINED LIMITS

Each Bus could determine the power transfer distribution function (PTDF) of each line to which it is connected given by and transfers from neighboring bus coordinating a procedure with that bus.  $PTDF_{1-2,i}$  stands for the power transferred to line  $i$  given a transfer between buses 1 and 2. Buses could determine this value empirically following a simple protocol upon start up or any change in system topology. Bus 1 and 2 could synchronize a predetermined power step and measure the impact on the other lines. From the PTDFs the line outage distribution functions (LODF) can be calculated.

$$LODF_{l,k} = \frac{PTDF_l}{1 - PTDF_k}$$

Using the LODFs the buses can use the following process to determine the security constrained limits.

1) A Bus takes the vector of its thermal limits,  $T_o$ , with its neighbors,  $N$ .

For each neighbor  $v$  in  $N$  take the  $T \cdot v \cdot LODF_{v,\gamma} = C$  where  $C$  is a

Contingency vector and  $\gamma$  represents all other neighbors  $\gamma \neq v$ . For each

neighbor  $\gamma$  send  $C(\gamma)$ . Neighbor  $\gamma$  subtracts  $C$  from  $T_{o,\gamma,v}$  to form the

security constrained limit,  $SC = T_{o,\gamma,v} - C$ . Bus  $\gamma$  repeats the process used



by  $v$  and so on until a Bus,  $\zeta$ , signals that  $SC'' > T_0$  where  $SC'' - T_0 = \Delta T$ . In

that case the bus that initiated the iteration  $v$ , must reduce its limit by

$\prod_{i,j} LODF_{i,j} \cdot \Delta T$ . The power is reduced, and the process begins again using

$SC$  as the input limits until no bus signals a violation, and the system is N-

1 secure. dependent on topology.

## REFERENCES

[1] SunPower Corporation. *The Drivers of The Levelized Cost of Electricity for Utility-Scale Photovoltaics*. SunPower Corp. 2008.

Prediction utilizes a Levelized Cost of Electricity, with 8% discount rate, 1%/yr degradation, \$.02/kWh maintenance, 20% annual cost reductions and initial cost of \$3500/kW (SunPower Corp., 2009).

[2] Solar Energy Industries Association. *US Solar Industry Year in Review. 2008*. March, 2009.

[3] Deutschbundesnetzagentur. *New German Grid Codes for Connecting PV Systems to the Medium Voltage Power Grid*. Bundesnetzagentur. 2009.

[4] Chaudhari, Maya. Frantzis, Lisa. Hoff, Tom. *PV Grid Connected Market Potential Under a Cost Breakthrough Scenario*. Navigant Consulting. September, 2004.

[5] Prof. Zeman TU Delft Electrical Engineering, Mathematics and Computer Science. Deft University Website. August, 2011.

[6] Radiance Solar. *Kennedy Project Cost Report*. Jan, 2010.

[7] Gao, Jifan. Trina Solar. *Solar Energy News*. September 17, 2009.

[8] Hassan, Russell. *A Research Report on Solar Power Investment: The Dawn of Solar Power*. Alternative Energy News Source. 2010.

[9] Khosla, Vinod: *What Really Matters in Thin Film Solar Startups?* Greentech Media. June 16, 2010.

[10] <http://www1.eere.energy.gov/solar/sunshot>.

[11] Kirby, B. J., J. Dyer, C. Martinez , Dr. Rahmat A. Shoureshi , R. Guttromson, J. Dagle. *Frequency Control Concerns In The North American Electric Power System*. DOE. December, 2002.

- [12] Undrill, J.M, *Power and Frequency Control as it Relates to Wind-Powered Generation*. 2010.
- [13] Jewell, Ward. R. Ramakumar, *The Effects of Moving Clouds on Electric Utilities with Dispersed Photovoltaic Generation*. IEEE Transactions on Energy Conversion. pp. 570-576. December 1987.
- [14] Mills, Andrew. Ahlstrom, Mark. Brower, Michael. *Understanding Variability and Uncertainty of Photovoltaics for Integration with the Electric Power System*. Lawrence Berkeley National Laboratory. December, 2009.
- [15] Mills, Andrew and Wiser, Ryan. *Implications of Wide-Area Geographic Diversity for Short Term Variability of Solar Power*. Lawrence Berkeley National Laboratory. September, 2010.
- [16] Hoff, Tom. Perez, Richard. *PV Power Output Variability: Calculation of Correlation Coefficients Using Satellite Insolation Data*. Clean Power Research. March, 2011.
- [17] Lave, Matthew. Kleissl, Jan. *Solar Variability of Four Sites Across the State of Colorado*. Renewable Energy 35 2867-2873. 2010.
- [18] BP Solar. Annual Variation of Insolation in Kassel, Germany. 2006.
- [19] Australia Power and Gas.com.au/
- [20] Intergratingrenewables.com
- [21] Deutsche Energie-Agentur GmbH (DENA). *Energy Management Planning for the Integration of Wind Energy into the Grid in Germany, Onshore and Offshore by 2020*. Cologne, Germany. 2005.
- [22] Warren Frost, Jim McIntosh. *Wind Generation Integration*. NERC MRC Meeting May 6, 2008.
- [23] California Energy Commission (CEC). *Review of International Experience Integrating Variable Renewable Generation. Appendix B: Germany California Intermittency Project*. 2007.

- [24] Sensfuß, Frank. *Assessment of the Impact of Renewable Electricity Generation on the German Electricity Sector: An Agent Based Simulation Approach*. University of Karlsruhe. 2007.
- [25] U.S. Department of Energy (DOE). *Natural Gas and Electricity Costs and Impacts on Industry*. DOE/NETL-2008/1320. April, 2008.
- [26] [www.pjm.com](http://www.pjm.com)
- [27] California ISO (CAISO). *Spinning Reserve and Non-Spinning Reserve. CAISO Settlements Guide*. January, 2006.
- [28] Trudnowski, Daniel. Donnelly, Matt. Lightner, Eric. *Power System Frequency and Stability Control using Decentralized Intelligent Loads*. IEEE Power Engineering Society T & D Conference and Expo. 2005.
- [29] S. Grijalva, M. Costley, N. Ainsworth, “Prosumer-Based Control Architecture for the Future Electricity Grid”, IEEE Multi-Conference on Systems and control, Denver, CO, September, 28-30, 2011.
- [30] Energy Information Administration. *Electric Power Industry 2009: Year in Review*. 2009.
- [31] Federal Energy Regulatory Commission. *Assessment of Demand Response and Advanced Metering: Staff Report*. December 2008.US
- [32] Gilmore, Elisabeth. Lave, Lester. *Increasing Backup Generation Capacity and System Reliability by Selling Electricity during Periods of Peak Demand*. 26th USAEE/IAEE North American Conference, September, 2007.
- [33] Osborn, Mark. Phone Interview. May, 2011.
- [34] United States Combined Heating and Power Association. *CHP Overview*. 2002.
- [35] Danish Energy Authority. *Combined Heat and Power Production in Denmark*. 2011.

[36] National Renewable Energy Laboratory (NREL). [ww.nrel.gov](http://www.nrel.gov). 2011.

[37] R. D. Zimmerman, C. E. Murillo-Sánchez, R. J. Thomas and Deqiang Gan. MATPOWER. <http://www.pserc.cornell.edu/matpower>. 2011.

[38] The Joint Board for the PJM/MISO. *Region Report on Security Constrained Economic Dispatch. Docket No. AD05-13-000 Submitted to the Federal Energy Regulatory Commission*. May 24, 2006.