

Mission Profile Based Reliability Design and Real-time Life Consumption Estimation in Power Electronics

Mahera Musallam, Chunyan. Yin, *Member, IEEE*, Christopher Bailey, *Fellow, IEEE* and Mark. Johnson, *Member, IEEE*.

Abstract— Power electronics are efficient for conversion and conditioning of the electrical energy through a wide range of applications. Proper life consumption estimation methods applied for power electronics that can operate in real-time under in-service mission profile conditions will not only provide an effective assessment of the products life expectancy but also they can deliver reliability design information. This is important to aid in manufacturing and thus help in reducing costs and maximizing through-life availability. In this paper, a mission profile based approach for real-time life consumption estimation which can be used for reliability design of power electronics is presented. The paper presents the use of electro-thermal models coupled with physics-of-failure analysis by means of real-time counting algorithm to provide accurate life consumption estimations for power modules operating under in-service conditions. These models, when driven by the actual mission profiles, can be utilized to provide advanced warning of failures and thus deliver information that can be useful to meet particular application requirements for reliability at the design stage. To implement this approach, an example of two case studies using mission profiles of a metro-system and wind-turbines applications are presented.

Index Terms— Power electronics, Mission profile, Electro-thermal models, Real-time, Physics of failure, Life consumption.

I. INTRODUCTION

Power electronics emerge as the only technology that can deliver efficient and flexible conversion and conditioning of the electrical energy. It is becoming increasingly important in a wide range of transport and energy applications including smart grids, aerospace, electric and hybrid cars, industrial process control, consumer electronics and lighting. Increasing reliance on power electronics in such applications raises great concerns for equipment to be available when needed with a minimum risk of failure in service. Proper reliability assessment and prognostics methods that can be applied to

power electronics are key enablers for achieving efficient system level maintenance and lower life cycle costs [1-5].

Reliability of a power electronics system is its ability to perform as intended for a specified period of time in its lifecycle environment [6, 7]. The environmental and operating conditions applied to power electronic modules, such as temperature changes or load cycling cause degradation and ultimately failure. Failures in power electronics may occur at different rates for different module designs and applications where the thermal cycling or exposure to extreme temperatures can be as a result of changing environmental or operational (load) conditions [8-10]. The demand for high reliability systems requires long term service with fault-free operation [11, 12].

Applying suitable health management techniques in power electronics systems includes performing reliability analyses of equipment, collecting and analyzing data, studying and understanding the failures in these systems, lifetime prediction of the components and monitoring of the system performance. Reliability and health management tools that can accurately predict the remaining life of a power electronic system are highly desirable for availability in critical applications since they can greatly aid in providing advance warning of failures, minimizing unscheduled maintenance and extending maintenance cycles, reducing the life cycle cost of equipment thus reducing operating costs and minimizing disruption to services [7, 13-15].

In power semiconductor modules; for example IGBT (Integrated Gate Bipolar Transistor) modules such as the one shown in Fig.1, the dominant wear-out mechanisms are generally driven by thermo-mechanical effects, for example by thermal cycling or by long-term exposure to extreme temperatures [16-18]. The heat transfer path from die to coolant consists of many different materials (Fig. 2), each characterized by different physical properties, in particular different coefficients of thermal expansion and different mechanical stiffness. When exposed to temperature fluctuations, the power modules experience repetitive thermal cycling which creates stresses at various locations within the power modules particularly at interfaces between dissimilar materials, such as wire bonds and solder layers.

Manuscript received 1st April 2014. Mahera Musallam is with Manchester Metropolitan University, Manchester, M1 5GD, United Kingdom. (e-mail: m.musallam@mmu.ac.uk). Chunyan Yin is with the University of Greenwich, 30 Park Row, London, United Kingdom. (e-mail: C.Yin@greenwich.ac.uk). Christopher Bailey is with the University of Greenwich, 30 Park Row, London, United Kingdom. (e-mail: C.Bailey@gre.ac.uk). Mark Johnson is with the University of Nottingham, University Park Nottingham, NG7 2RD, United Kingdom, (email: Mark.Johnson@nottingham.ac.uk).



Fig.1. Example of a typical (dual switch) half bridge IGBT power module (300A,1200V) consisting of two IGBTs and two Diodes

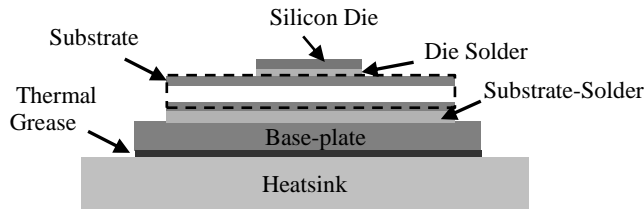

Fig. 2. A schematic of the internal structure of a typical IGBT module.

Thermal stress can generate thermal deformation causing fatigue and eventually failure [19-21] because of the difference of the coefficients of thermal expansion (CTE) and different mechanical stiffness of power modules' materials. In these modules, degradation in bond wires and solder layers are difficult to detect from simple external measurements of parameters such as forward voltage or module base-plate temperature until the final stages of wear-out.

Traditional reliability prediction methods for electronic products include MIL-HDBK-217 [22], Tecordia [23], PRISM [24], and FIDES [25]. These methods rely on a set of collected failure data and generally assume constant failure rates and use modifiers to account for various quality, operating and environmental conditions. Furthermore, none of these handbook prediction methods identify failure modes or mechanisms, nor do they involve any uncertainty analysis. Hence, they offer limited insight with serious faults into practical reliability issues. A number of approaches reported in the literature [26-28] have been used for products reliability assessment such as prognosis and health management of power devices (PHM) [9, 29]. Such methods can be considered as a practical alternative way of looking at product reliability and life cycles conditions where the remaining useful life of the product can be predicted by assessing the extent of degradation from the product's original state of health and its expected usage conditions [30-32].

Condition monitoring techniques are used for monitoring potential operating characteristics of the system under test, so that the change of the monitored characteristics can be used to schedule maintenance before serious deterioration or break down occurs [33]. Condition monitoring uses sensor based systems to provide prognosis of degradation through monitoring the device degradation over a period of time [34]. Examples of existing prognostic approaches include Canaries [35, 36], which implement sensor-based systems to monitor

selective electrical or thermal parameters such as excessive current, voltage, temperature or power dissipation against a threshold value. Other methods such as data driven techniques use the current and historic information of selected parameters to derive estimates of the remaining useful life of the product [37-39]. These methods rely on statistical and probabilistically built analysis to derive the required estimates. Although the sensitivity of data driven methods can be increased through additional sensors and measurement hardware, however, this will increase costs and possibly reduce the overall reliability of the system.

Other methods include physics-of-failure techniques [40 - 44] which are based on modelling the failure mechanism. This science based approach using both computer modelling and experimental techniques, can potentially provide more accurate reliability predictions than the traditional handbook methods. The Physics-of-Failure (PoF) approach utilizes knowledge of the life-cycle load profile package, architecture and material properties to identify potential failure mechanisms. PoF based reliability analysis and prediction methods played an increasingly important role in the power electronics modules design and failure analysis [45-48].

Failures of different potential points of the power module such as the wire bonds and the substrate-solder have different physical driving mechanisms and will thus exhibit different wear-out rates in different applications. Therefore, understanding the actual effects of applied mission profiles to the power modules in use as well as the root causes of failures will greatly help in defining the wear-out criteria and providing proper life modelling predictions.

This paper presents a mission profile based reliability design approach which makes use of real-time life consumption estimation methods for power electronics operating under in-service applications. This work has two main purposes; firstly, to deliver a model based method for power modules' life consumption estimation under real-time in-service conditions. The second purpose is to present an approach suitable for reliability design which is based on life consumption estimation in power modules and the effects of mission profiles. Predicting life consumption driven by the actual mission profiles defines particular effects on the failure criteria. Thus, it is important to note that the response of typical wear-out mechanisms, to in-service environmental or load-induced thermal cycling differs depending on the applied loading conditions.

In this paper, two different mission profiles are applied on-line to the power electronic system separately. Real-time life consumption of the power modules is then determined accordingly. The knowledge obtained from this work provides information that helps to design particular accelerated tests for life time determination which are fundamental to the design and qualification of power electronic modules. In addition, designer engineers can make use of real-time mission profile induced life expectancy data to optimize the design of products to achieve reliability targets and help as such in reducing costs and maximizing through-life availability.

II. FRAMEWORK OF THE PRESENTED METHOD

The presented method starts by defining the physical parameters of the studied power electronic system. Through various multi-physics analyses and modelling of the interactions of different domains such as the electrical-thermal effects, the system dynamic behavior could be represented. Compact electro-thermal models which account for the systems' boundary conditions and mission profile were then constructed. Through studying the root causes of common failures in power electronics, physics-of-failure life time models were developed. These models are integrated with the temperature-time data as outputs of the compact models using real-time counting technique to give a proper reliability assessment of life consumption of those power modules in use. Fig. 3 shows a block diagram illustrating the framework of the presented work.

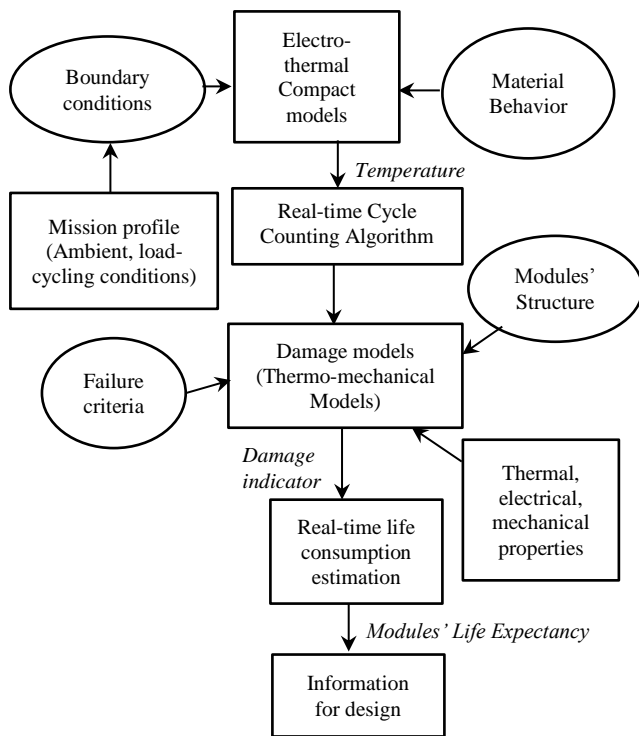

Fig. 3. Framework for reliability design in power electronics based on mission profile and life consumption analyses.

This method consists of the following main steps:

A. Construction of real-time compact electro-thermal model

Power losses model combined with a developed thermal model were used to provide a real-time compact electro-thermal model for a full bridge IGBT converter. The full bridge consists of two dual switch IGBT power modules, each of ratings 300A and 1200V similar to that shown earlier in Fig. 1. Each module or half bridge (leg) combines six IGBT dies and six diode dies.

The construction of the compact thermal model was obtained by experimental measurements of the consumed losses (conduction and switching losses) within each internal material layer of the power modules at different temperature

ranges. Power losses were then fed to the compact model which is based on simplified multi-exponential forms that represented the heat transfer functions within each internal component [49]. The developed model considers the material behaviour, the ambient conditions and load cycling profile. This model is used to estimate temperatures of any significant point within the power modules such as the die junction temperature, substrate, and base plate temperature. Hence, it provides an accurate representation of the dynamic electro-thermal behavior of the power modules.

B. Cycle counting

In many reliability design and model-based health management applications where load profiles are variable and unpredictable, it is desirable to have efficient cycle counting methods to identify equivalent full and half cycles of the irregular load profile. In literature, cycle counting algorithm such as rainflow method [50, 51] is used to summarize irregular load-versus-time histories by providing the number of times cycles of various sizes occur. The definition of a cycle varies with the method of cycle counting. Cycle counts can be made for time histories of force, stress, strain, acceleration, or other loading parameters. In this paper an alternative approach of cycle counting algorithm is used. It is implemented in real time and hence it is easily integrated with the real-time compact model to automatically obtain the output temperature cycles.

C. Thermo-mechanical models (Damage models)

Reduced order thermo-mechanical models were developed based on studying the failure criteria within the power modules. In this paper, wire bond and substrate-solder failure mechanisms which are common in power modules are considered. Finite Element Analysis (FEA) modelling was constructed considering the modules' geometrical structure, the thermal and mechanical properties of power modules' materials. In addition, the effects of the interactions between the thermal and mechanical domains which derive the potential failures are considered. With a combination of thermal fatigue testing [52] coupled with detailed FEA modelling, reduced order thermo-mechanical models were developed.

D. Prediction of modules' life consumption.

The actual dynamic thermal behavior of the power modules represented as temperature-time data is integrated with the thermo-mechanical models to give a prediction of the life consumption of the power modules under test. This work makes use of Coffin Manson model [53-55] as a typical method to estimate the number of cycles to failure for both the wire bond and substrate-solder wear-out mechanisms separately:

$$N_f = \frac{L}{\alpha(\Delta\epsilon_p)^b} \quad (1)$$

where L is the solder crack length, $\Delta\epsilon_p$ the damage indicator representing the accumulated plastic strain per cycle, N_f is the number of cycles to fail, α and b are constants derived from the material's characteristics. Based on the total accumulated

plastic strain, the number of temperature cycles to fail can be calculated. Life consumption estimation is calculated for each failure mode separately based on the number of cycles to fail as follows:

$$LC = \frac{1}{N_f} \quad (2)$$

For different applied loads, the Palmgren-Miner linear damage accumulation rule can be used to give an estimation of the product life consumption as follows [56-58]:

$$LC = \sum_i^k \frac{n_i}{N_{fi}}$$

$$LC = \left[\frac{n_1}{N_1} \right]_1 + \left[\frac{n_2}{N_2} \right]_2 + \left[\frac{n_3}{N_3} \right]_3 + \dots + \left[\frac{n_k}{N_k} \right]_k \quad (3)$$

where i refers to the different applied loads, $i = 1, 2, 3, \dots, k$. n_i and N_{fi} are the number of cycles and the number of cycles to fail respectively for each different load from 1 to k .

Life consumption prediction for power modules employed in critical condition applications is highly desirable. Life consumption prediction techniques can be employed as part of a real-time health management system to provide advance warning of failure and thus guide preventative maintenance and reduce cost.

E. Information for design

Life consumption information of power modules that accounts for the actual effects of applied mission profiles can not only be useful as a health management tool but also it can provide information useful at the design stage to realize reliability targets and obtain better performance of power modules. Different mission profiles can affect the power modules' life expectancy differently. Depending on the applied loading profiles, information for reliability design can be provided to optimize the design of power modules for particular applications.

III. COMPACT ELECTRO-THERMAL MODEL

Power semiconductor modules such as IGBTs (Integrated Gate Bipolar Transistors) are used for high power switching in many real-life applications such as energy and transport applications. Models that can provide an accurate representation of the internal dynamic thermal behavior of power modules are useful when combined with damage based models to provide life consumption estimation of power modules in use. There are many approaches used to analyze the thermal behavior of power modules, for example; the three-dimensional finite element method (3-D FEM) [59]. Although 3-D FEM simulation delivers good results, it is unfeasible when used with real-time arbitrary load profiles. FEM cannot be accurately applicable for real-time unpredictable load profiles. Moreover, 3D FEM uses huge computational processes that cannot be interfaced with applications in real time especially in higher switching applications. Other models [60] can be useful for prediction of inverter reliability but they are not applicable in real-time and under in-service operations.

Previous work by the authors [49] presented the construction of real-time compact electro-thermal models for a typical full-bridge IGBT converter. The full-bridge converter has two half-bridge IGBT power modules, each of ratings 300A and 1200V. As mentioned in [49], the electro-thermal model provides a compact model that counts for the electro-thermal analysis in each internal layer within the IGBT power modules. Based on the assumption that each region within the power module is assumed to have uniform, constant thermal properties and that the heat sources are confined to the semiconductor dies and can be treated as sources of surface heat flux, the thermal behavior of the whole module can therefore be represented by an $M \times (N + L)$ transfer function representing both self-heating and cross-coupling effects. M here represents the monitor points within the power module, N refers to the heat sources and L refers to the defined boundary conditions. The temperature responses of the surface layers and the other different layers of the power module package can be generated and represented as follows:

$$\mathbf{T}_m(s) = \sum_{n=1}^N \sum_{k=1}^{Kmn} \frac{A_{mnk}}{s + \alpha_{mnk}} \mathbf{P}_n(s) + \sum_{l=1}^L \sum_{k=1}^{Kml} \frac{B_{mlk}}{s + \alpha_{mlk}} \mathbf{T}_{bl}(s) \quad (4)$$

where m ($m \in 1, 2, \dots, M$) refers to the monitor points such as die, solder, substrate...etc., n refers to the heat sources ($n \in 1, 2, \dots, N$), $\mathbf{P}_n(s)$ is the laplace transform of the n th imposed heat source boundary condition, $\mathbf{T}_{bl}(s)$ is the laplace transform of the l th imposed temperature boundary condition ($l \in 1, L$).

Under dynamic operating conditions, the temperature achieved by a particular device is a function of the time-history of power dissipation within the module. This model counts for multiple heat sources and the temperature of any point in the module is represented as a linear superposition of effects from each heat source. The heat flux from any device dissipating power to the heatsink will affect the temperature of other devices within the module (Fig. 4).

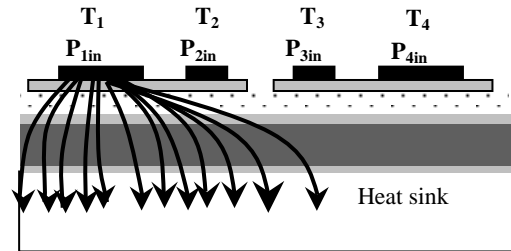

Fig. 4. A schematic of an example power module showing the self-heating and cross-coupling effects.

The thermal model parameters for each device, including the self-heating and cross-coupled heating effects, were determined over pre-defined ranges of temperature and current through step response measurements [49, 61]. For interfaces away from the surface, such as solder layers; a validated Flotherm [62] model was developed to predict the temperatures of the solder layers and other internal layers (interface layers away from the surface) within the module [61]. To implement properly the thermal model, the

mathematical relationships between temperature, input power and time constant for each element of the heat path are considered. Simplifying equation (4), each heat path within the power modules can be represented as follows:

$$T_n = \frac{1}{C_n} \int (P_{in} - \frac{T_n}{R_n}) dt + T_A \quad (5)$$

The temperature of each layer within the power module can be represented as a function of input power, module thermal parameters (R, C) and the ambient temperature (T_A). Using a discrete form with explicit time propagation of variables, the module's dynamic thermal behavior can be presented in the form of an $M \times N$ transfer function matrix (equation (6)).

$$\begin{bmatrix} T_{J1} \\ T_{J2} \\ \vdots \\ T_{JN} \\ T_{Solder_2} \\ T_{Substrate} \\ T_{Solder_1} \\ T_{Baseplate} \end{bmatrix} = \begin{bmatrix} a_{11} a_{12} \dots a_{1N} \\ a_{21} a_{22} \dots a_{2N} \\ \vdots \\ a_{N1} a_{N2} \dots a_{NN} \\ \vdots \\ \vdots \\ \vdots \\ a_{M1} a_{M2} \dots a_{MN} \end{bmatrix} \begin{bmatrix} P_{in} \\ P_{2in} \\ \vdots \\ P_{Nin} \end{bmatrix} + T_A \quad (6)[49]$$

The matrix terms $a_{11} \dots a_{MN}$ represent the transfer function of each heat transfer path, T_A is the ambient temperature, $P_{1in} \dots P_{Nin}$ are the heat sources and $T_{J1} \dots T_{JN} \dots T_{Baseplate}$ are the temperatures at certain points within the module such as the device junctions, solder, substrate and baseplate. The response of the m 'th point to a step input at the n 'th heat source can be extracted from the transfer function matrix (6), and is represented in a general form as follows:

$$T_m(t) = \sum_{k=1}^{Kmn} \frac{A_{mnk}}{\alpha_{mnk}} (1 - \exp(-\alpha_{mnk}t)) \quad (7)$$

The coefficients A_{mnk} and α_{mnk} , were obtained by curve fitting using the least squares method on the temperature vs. time data which is obtained from both measurements undertaken on the defined module structure and simulation results using Flotherm [49, 61].

The real-time compact model was developed in MATLAB/Simulink [63] using the real-time software toolbox and implemented on a dSPACE [64] real-time system which incorporates a hardware PWM card (DS5101). This model is well suited to the continuous monitoring of the internal behavior of the electro-thermal effects within power electronic modules in response to any operational profile.

IV. REAL-TIME CYCLE COUNTING

Off-line rainflow counting [50, 51] is a typical approach that can be used to generate temperature range histograms to identify regular load cycles for irregular in-service data profiles. In typical implementations, this counting algorithm considers the entire time history of the load as an input, and the equivalent cycles are then determined at the end of that time history [65, 66].

Using the traditional counting approach is feasible for single load conditions' applications [67] when cycles counting

for each regular individual load profile can be provided independently. However, this approach is inconvenient in real-time applications because the algorithm must be applied periodically to large data-sets and thus it requires processing all stored data at the same time, which then makes it difficult to integrate with other converter control processes.

To address the challenges in implementing the rainflow counting algorithm in real-time, a new approach is introduced in which each maxima or minima value is processed as it occurs [68]. The counting algorithm is integrated with the real-time interfacing tools on the dSPACE real-time platform. Reference [68] provides more details about the development and implementation of the real-time counting algorithm. This approach can be easily integrated within real-time applications. It needs less data storage and it preserves the complete information (mean, and ΔT) for each cycle. Thus, it is expected to offer better resolution and higher accuracy.

V. THERMO-MECHANICAL MODELS (DAMAGE MODELS)

Previous detailed studies of the wear-out mechanisms had been carried out by the authors based on damage and fracture mechanics to predict stress, damage and reliability. Differing from the traditional handbook methods, physics-of-failure (PoF) based reliability analysis emphasizes the understanding of the physical processes and mechanisms of failures. These approaches use physics-based models to predict stress, damage and reliability [52, 69]. A number of preliminary models have been developed for IGBT modules [70-72]. By combining computer modeling and failure mode/mechanism analysis methods, failures can be predicted before they occur by modeling the failure mechanism (crack propagation).

The work in this paper is restricted to two common failures observed in power modules; wire bond and substrate-solder failure mechanisms only. Fig. 5 and 6 show typical examples of such failures. Models for the wear-out through fatigue cracking of the aluminum bonding wires were derived involving a combination of thermal fatigue testing [52] coupled with detailed physical modelling. From the results obtained from these tests an empirical function that represents the lifetime model for the bond wire can be expressed as a function of the cyclic temperature ΔT [52]:

$$N_f = (1.4 * 10^{11}) \Delta T^{-3.597} \quad (8)$$

where N_f is the number of cycles to failure, here defined as the point at which wire lift-off occurs, and ΔT is temperature variation. This model describes the dependence of number of cycles to failure (N_f) on temperature difference (ΔT) but it doesn't include time domain analysis of failure progression [73]. The model is strictly valid for $50^\circ C \leq \Delta T \leq 180^\circ C$. For the purposes of calculating life consumption, it is extrapolated for values of $\Delta T \leq 50^\circ C$. This is a reasonable assumption provided the mechanics of the wear-out process remain the same for lower temperature fluctuations. Fig. 7 represents the life time extraction model for the IGBT bond-wire over a range of temperature variations.

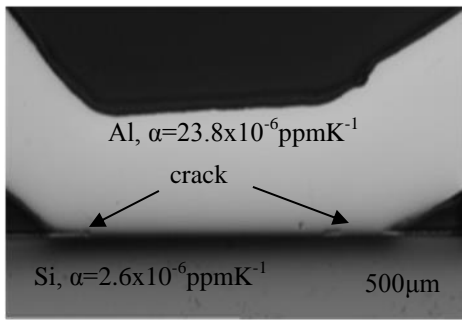

Fig. 5. Example of wire-bond failure

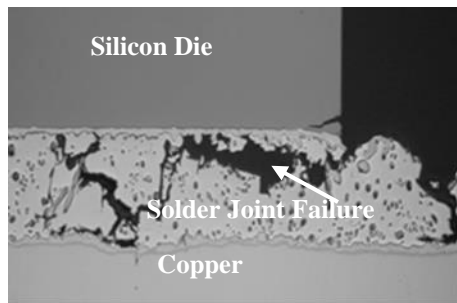

Fig. 6. Example of solder failure

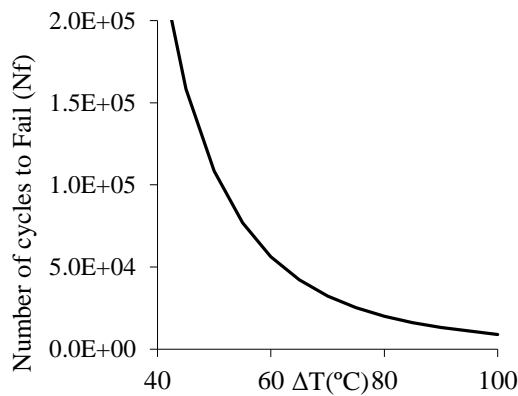

Fig.7. Life time extraction model for the IGBT bond-wire interconnect [52].

Thermal fatigue tests were performed for the solder-substrate joints (solder layer connecting the isolation substrate to the baseplate) and then investigated by simulating the crack growth process under a set of prescribed field temperature profiles that cover the period of the operational life. As fatigue is driven by the temperature profile of the power module, the degree of the damage of the solder interconnect can be estimated based on the module's temperature history [74, 75]. A strain-based model for solder-substrate was developed by the combination of the damage information from thermal fatigue experiments with computer modeling using Finite Element Analysis (FEA) [76]. FEA modeling was undertaken at different design points and the damage criteria was defined as the time it takes for the crack to have an area that equals 20% of the total solder interconnect area. In order to identify the best fitting function for the accumulated plastic strain $\Delta\epsilon_p$ per cycle, the least square fitting technique was used to provide an approximation model which relates the plastic strain ($\Delta\epsilon_p$) per cycle with the two design variables (ΔT , T_m). As a result, a reduced order thermo-mechanical model for the

solder (SnAg) material was developed. Solder material properties which were used to develop this model, can be found in reference [10]. The model is represented as follows:

$$\begin{aligned} \ln(\Delta\epsilon_p) = & -17.73 + 0.2984\Delta T + 0.07957T_m - 0.001722\Delta T^2 \\ & - 0.0002478T_m^2 - 0.0005389\Delta T T_m \end{aligned} \quad (9)$$

The model in (9) is integrated with Coffin-Manson model in (1) and the number of cycles to fail for the substrate-solder layer can be calculated as presented in equation (10).

$$N_f = \frac{L}{0.0056(\Delta\epsilon_p)^{1.023}} \quad (10)$$

where L is the solder crack length and the constants 0.0056 and 1.023 are derived based on the characteristics of the solder material [10]. It should be noted that the model in equation (9) is valid for mean temperatures between 24°C and 90°C and ΔT between 6°C and 90°C. It is notable that the mathematical form of equation (9) is unrealistic for small ΔT since $\Delta\epsilon_p$ does not tend to zero as ΔT tends to zero. Thus, the model in equation (10) predicts an unrealistic finite life at zero ΔT and is thus not suitable for general reliability prediction. To avoid this problem, a revised functional form of the model in (10) is used in which the coefficients are functions of the mean temperature as in the following equation [77]:

$$N_f = A(T_m)\exp(B(T_m)) \quad (11)$$

$A(T_m)$ and $B(T_m)$ are the coefficients of equation (11) and they are functions of the mean temperatures (T_m). For each individual mean temperature (T_m) the accumulated plastic strain $\Delta\epsilon_p$ per cycle in equation (9) is calculated over a range of different ΔT values then N_f (number of cycles to fail) at that particular mean temperature is obtained using equation (10). Fig. 8 illustrates the substrate-solder lifetime model and individual curve fits for the model of equation (11) as a function of the temperature variations at different mean temperatures.

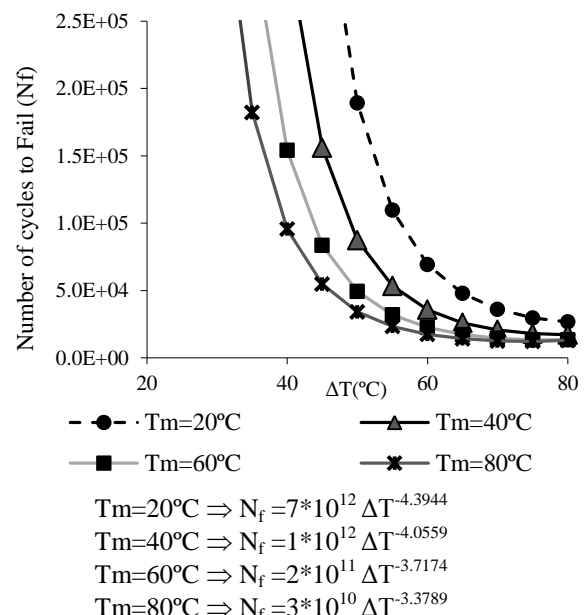

Fig. 8. The substrate-solder life time model as a function of the temperature variations at different values of mean temperatures.

Each curve represents the number of cycles to fail as a function of the temperature variations within the solder-substrate layer at an individual mean temperature.

VI. APPLICATION OF THE REAL-TIME LIFE CONSUMPTION METHOD

The prescribed method is applied to predict life consumption of power modules under in-service loading conditions. The load profile is applied to a full-bridge IGBT converter as shown in Fig. 9. This system uses a fully inductive load with ambient (coolant) temperature at 40°C. The thermal model described earlier is updated and implemented in real-time using dSPACE system which is connected to the test rig via proper A/D interface connectors.

With the knowledge of the operational profile, the power dissipation in each device is obtained at each PWM cycle using lookup tables which are functions of the system phase current, duty ratio and the estimated temperatures. Once the load profile is operating, the power dissipation within each device of the power module under test is calculated at the PWM cycle frequency (5 kHz) [49]. The heatsink temperature is controlled in real time via the current controller which uses real-time measurement updates. The real-time thermal model is updated with the averaged power dissipation to obtain the real-time temperature estimates at 1 kHz [49].

Having obtained temperature estimates for the significant features in the power module such as the die junction temperature, substrate, and base plate temperature, the cycle counting algorithm which is employed within the dSPACE real-time platform automatically calculates the number of cycles the temperature-time data encountered. The real-time rainflow counting algorithm processes these estimates in a flexible size buffer to identify the minima and maxima values. It then employs a stack-based method which is implemented using a recursive algorithm to define and pick out on-line full and half temperature cycles. Life-time models for the studied

wear-out mechanisms (wire-bond and solder-substrate failures) which are presented in equations (8 to 11) are integrated automatically with the thermal cycles as outputs of the rainflow algorithm to give an estimation of the life consumption of the power modules under test.

A. Prediction of modules' life consumption in metro-system applications

Increasing power density requirements and the challenging thermal environmental conditions in automotive applications [78] push the limits of motor, switching device, and thermal management technologies [79, 80]. In recent years, various research programs have been devoted to reliability in power electronics such as RAPSDRA (reliability of advanced power semiconductor devices for railway traction applications, 1995 -1998) [81]. These approaches have their limitations in analyzing and simulating such application profiles in real-time.

In this work, a metro-system mission profile is applied to the converters using dSPACE real-time platform. The metro-load profile is represented by the rms values of the phase current as illustrated in Fig. 10. The original profile has been descaled in amplitude to be suitable for application in the laboratory [82]. Each cycle pattern lasts for 151s and is defined by six distinct phases; an acceleration phase of 41s; a cruise phase of 37s at a speed of 60km/h, a braking phase of 10s, a cruise phase of 11s at a speed of 40km/h, a braking phase of 22s and a stop phase of 30s.

When the load profile is launched, the average power dissipation within the power modules is calculated automatically and applied on-line to the compact thermal models. Sample of the power dissipated within the modules is shown in Fig. 11. Typical results of the junction and the substrate-solder temperature estimates are shown in Fig. 12. Clearly illustrated the temperature variations for both the junction and the substrate-solder are of very irregular nature following the changes in the metro-system mission profile.

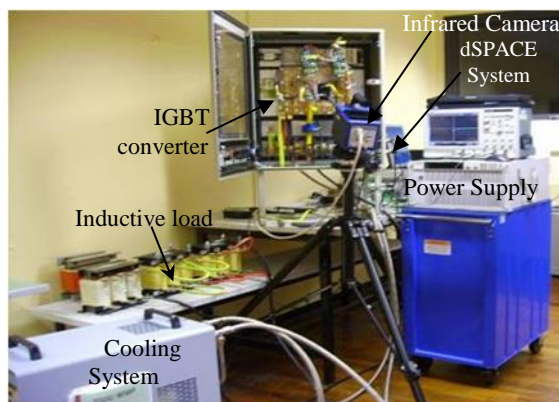

Fig. 9a. System test rig

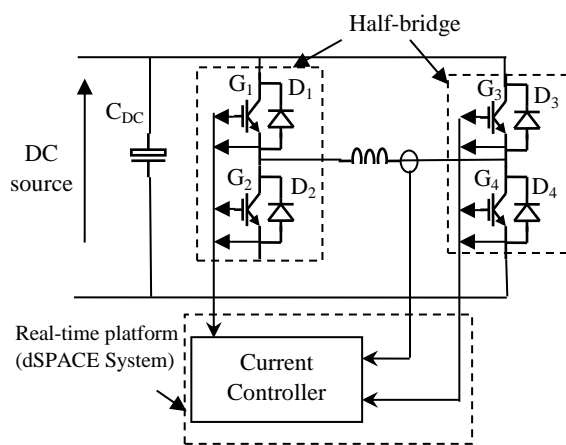

Fig. 9b. A schematic diagram of the IGBT converter under test.

Fig. 9. The full bridge IGBT converter under test.

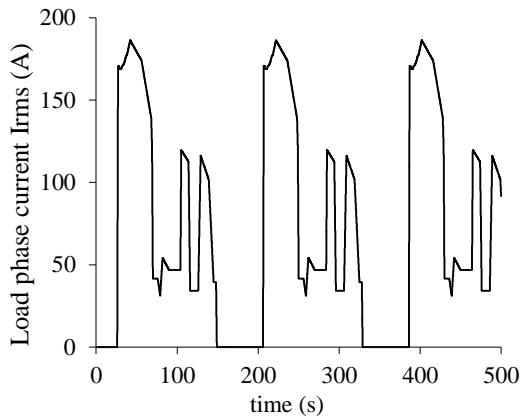

Fig. 10. Sample of phase current of a metro-system mission profile

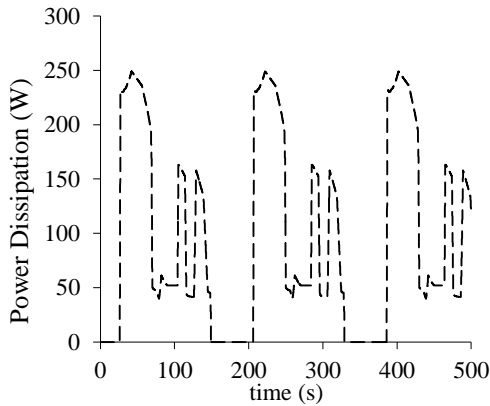

Fig. 11. Sample of the power dissipated within the power module

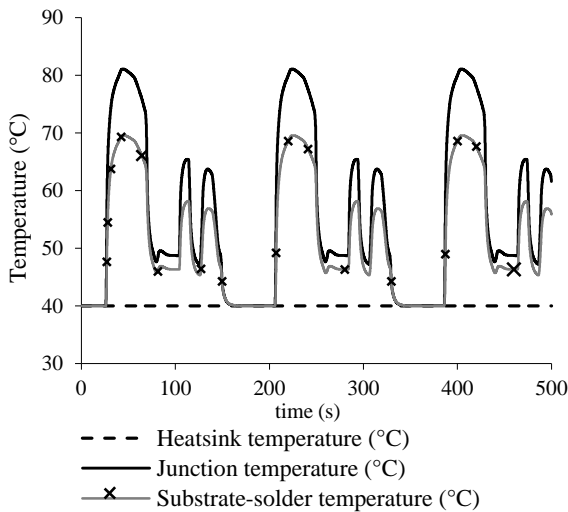

Fig. 12. Junction and substrate-solder temperature estimates

The real-time rainflow coding algorithm automatically works on picking out half and full cycles of the temperature variations. Fig. 13 shows a sample of the full and half cycles defined by the real-time rainflow algorithm for the junction temperature data. The life consumption for the bond wire under the effect of the metro-system mission profile is estimated online and is shown in Fig. 14 alongside the junction temperature variations.

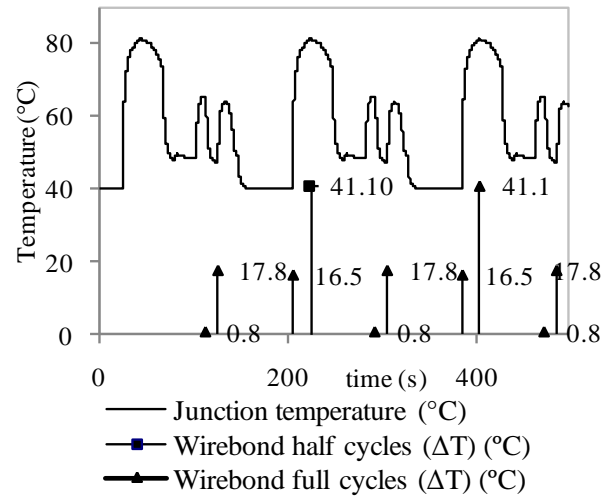

Fig. 13. Sample of the defined full and half cycles for the junction temperature data

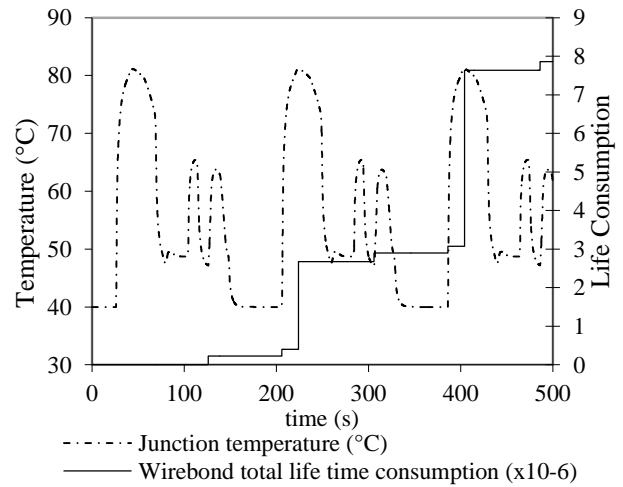

Fig. 14. Real-time life consumption for the bond wire

Under the same test conditions, the lifetime consumption for the substrate-solder is estimated simultaneously. Fig. 15 shows the substrate-solder temperature variations alongside its on-line life consumption. It is clear from the results that the life consumption for the substrate-solder is smaller than that of the wire bond due to the fact that the temperature variations in the substrate-solder layer are smaller than those of the junction.

The results in Fig. 14 and 15 show the real-time life consumption estimates for both the wire bond and substrate-solder respectively over one mission profile pattern which was applied for approximately 500s. Based on life consumption estimation and the duration over which this mission profile is applied; the observations in Fig. 14 show that the wire bond will last for approximately 17580 operating hours if running continuously under this load profile. From the results obtained in Fig. 15, the expected life for the substrate-solder is observed to be longer than that of the wire bond. The substrate-solder layer is expected to last for approximately 204248 operating hours.

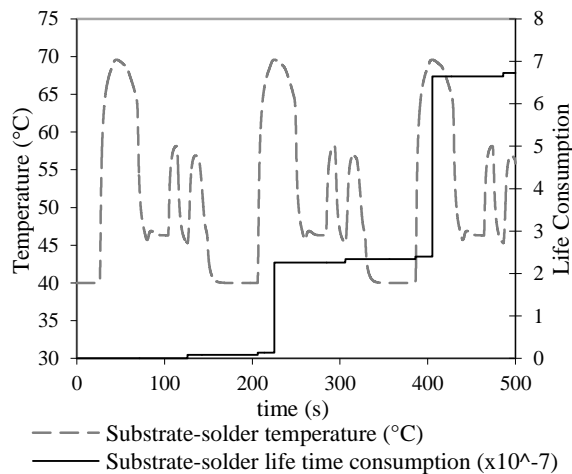

Fig. 15. Real-time life consumption for the substrate-solder

B. Prediction of modules' life consumption in wind turbine applications

The wind power nowadays plays much more important role in the energy supply system. Roles of power electronics in the wind turbine system are increasing especially in the last four decades [83]. However, studies of the reliability of wind turbine subassemblies [84] have revealed that failure of the power electronic converters is the most frequent cause of loss of generation. Whilst such units are not particularly expensive or difficult to replace in easy-to-access land-based systems, the cost of access to remote offshore wind farms potentially makes converter failure the greatest reliability challenge. It is thus critical to understand the reasons for such failures and identify techniques that can be used to reduce the need for expensive unscheduled maintenance.

Using the online real-time proposed method, the life consumption of power modules under the influence of wind turbine load profile is predicted. A variable wind speed profile, extracted from a real wind turbine which uses Doubly Fed Induction generator is shown in Fig. 16. The rotor load current is proportionally related to the power extracted from wind speed [85, 86]. The wind speed profile is used to derive the load current [87, 88] which is expected to be applied directly through the power converter. Note that the generator rotor current represents the phase current which is fed to the power electronics converter under test. This current is descaled to match the ratings of the tested power modules. Fig. 17 shows a sample of the generated rotor load current.

The on-line life consumption for the bond wire of the converters under test is obtained under the influence of the variable wind speed profile and is shown in Fig. 18. Through this test the wire-bond life could be estimated to last for 2.6×10^5 operating hours (approximately 30 years). Simultaneously, the results for the substrate-solder layer in Fig. 19 showed that it can last for approximately 2.05×10^8 operating hours.

In such applications where variable power cycling load profiles were applied to the converters, it was noticed that wire bond fails earlier [77]. Based on the tests and observations in this work, wire-bond failures can be considered the dominant

failure mechanism and the estimated life of the converter can be measured as the estimated life of the wire bonds.

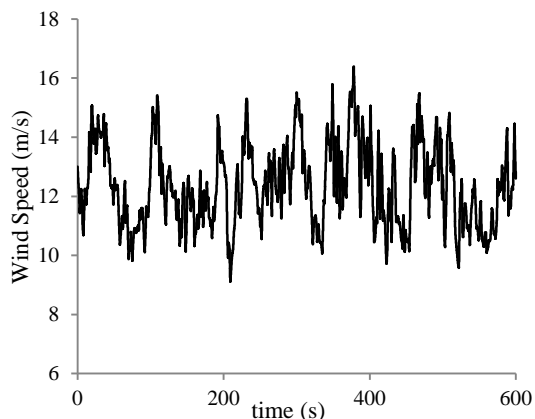

Fig. 16. Sample of wind speed profile (Rutherford and Appleton Laboratories)

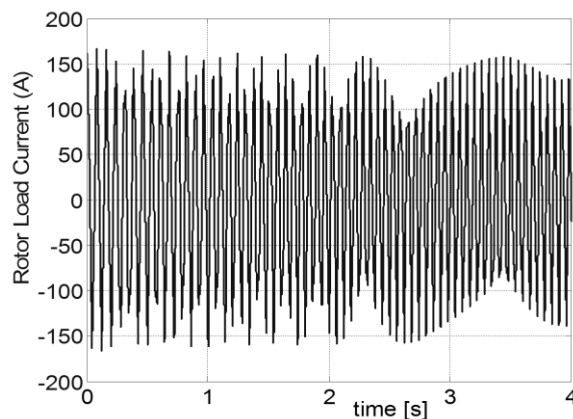

Fig. 17. Sample of the load current to the power converter.

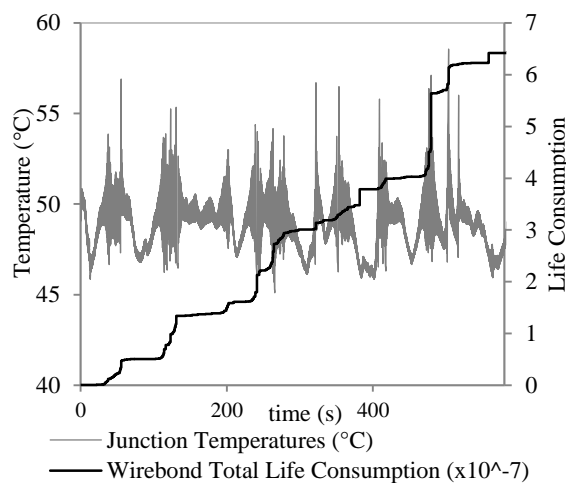

Fig. 18. Real-time life consumption for the wire bond alongside the junction temperatures

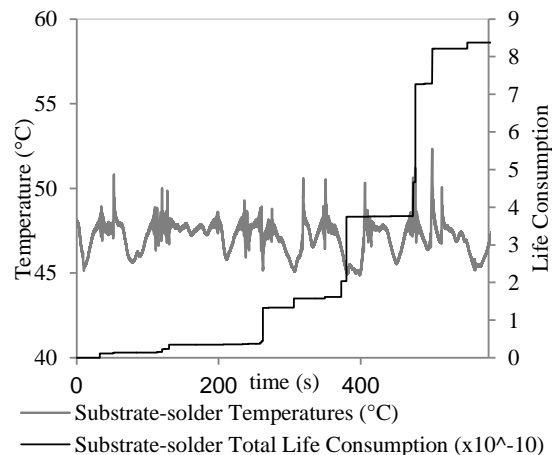

Fig. 19. Real-time life consumption for the substrate- solder alongside the layer's temperatures.

In both previous applications, the applied load is defined over one mission profile (one defined pattern) and the life consumption estimation is obtained accordingly. Recalling Palmgren-Miner linear damage accumulation rule (equation (3)), the number of the operational profiles (i.e. the number of instances that the mission profile is applied) that can be applied to the power electronics until failure, can be calculated. For example; considering the observations in Fig. 14, the number of times that the metro-system mission profile can be applied to the power modules before they fail is approximately 126581 instances. Simultaneously, based on the life consumption estimation obtained in Fig. 18, the number of times that such wind speed mission profile can be applied repeatedly before the power modules fail is approximately 1562499 instances. Knowledge obtained from these tests can provide particular reliability design information for each different application.

VII. DISCUSSION

The foregoing sections have described a method that can be used for reliability design in power electronics based on mission profiles and the use of real-time life consumption prediction. This work started by presenting the development of real-time compact electro-thermal model which is suitable to estimate the temperatures of any significant point within the power modules for example; the die junction temperature, substrate, and base plate temperature. Physics-of-failure models were developed for two common wear-out mechanisms in power electronics modules; wire-bond lift-off and solder-substrate degradation. The development of these models included several experimental and modelling techniques.

A combination of the compact electro-thermal model and physics-of-failure based models has been used in real time to quantify life consumption for power modules under prospective in-service real life applications. Application of real-time cycle counting algorithm makes it feasible to integrate temperature cycles with lifetime models easily in real time so that no further processes were interrupted during operation.

Different mission profiles have different impact on the power modules life consumption. The prescribed method was applied

to provide real-time life consumption for power modules under the effect of metro-system mission profile and wind speed mission profile separately. Life consumption estimation in each application is obtained over one mission profile (one defined pattern). Results showed that the life consumption estimates are different between both applications. This is understandable because each mission profile drives different thermal and mechanical effects within the power modules thus affecting the failure criteria differently. However, it was noticed that in both applications, wire bond failed earlier than the substrate-solder layer.

Limitations of the presented method can be due to the fact that it is a model based approach that does not provide real-time condition monitoring of the occurring failure. Accuracy issues may include accuracy of the temperature-time data and the wear-out models for the bond wire and substrate-solder. In [49], the compact model estimation results showed good agreement with the measured temperature-time data, providing confidence that these estimates can be used to drive an appropriate physics-of-failure model. Regarding the PoF models; the variability and limited availability of experimental reliability data coupled with limitations in the physical models employed, are likely to result in much larger sources of error. These limitations include FEA offline approximations to determine the wear-out rates. Besides, the lack of resources to verify these models experimentally in the related real life applications.

From the design perspective, the developed models when driven by the actual mission profiles can be utilised to provide advanced warning of failures and consequently provide design information that can be useful to meet particular application requirements for power modules. Information obtained by considering the effects of mission profiles on power modules life consumption can not only be useful as a health management tool but also it provides information useful to achieve reliability targets and hence improve the performance of power modules. The presented method can provide information that helps to design particular accelerated tests for life time determination. These tests can be based on specific application requirements or can be operation-dependent power cycling tests. Depending on the required information these tests are fundamental to the design and qualification of power electronics modules.

In addition, knowledge obtained from this work can be useful for devising design methods for power modules or power converters for particular load conditions that account for failure mechanisms such as wire-bond lift-off and substrate-solder degradation. Depending on the applied loading profiles, information for reliability design can be provided.

VIII. CONCLUSION

Reliability assessment and health management in power electronics are very important to meet reliability targets in the design field, maintenance and safety. Proper reliability assessment techniques can greatly aid in providing advance warning of failures, reducing unscheduled maintenance thus reducing operating costs and minimizing disruption to services. This paper presented a mission profile based reliability design approach which makes use of real-time life

consumption estimation methods for power electronics. The significance of this work is to provide life consumption prediction for power electronics under in-service conditions. Furthermore, it presents a successfully applied approach for reliability design based on the effects of mission profiles. The integration of the real-time temperature-time data with physics-of-failure analysis for defined wear-out mechanisms (wire-bond lift-off and substrate-solder failure) using real-time counting algorithm was useful to provide an estimation of products life consumption for complex load profiles. The main limitation of this method arises from uncertainty in the physics-of-failure models used to determine the wear-out rates.

Depending on the applied loading profiles, the presented reliability design method is useful to provide information which is fundamental to the design and qualification of power electronic modules at the design stage. Designer engineers can make use of such information as part of a health management scheme and in informing manufacturing to optimize the design to meet particular application requirements for reliability of power modules.

ACKNOWLEDGMENT

The authors thank the Innovative Electronics Manufacturing Research Centre (IEMRC) and EPSRC for funding this project and all the industrial partners i.e. Dynex Semiconductors ltd.

REFERENCES

- [1] M. Pecht, *Prognostics and Health Management of Electronics*, Wiley-Interscience, New York, NY, 2008.
- [2] Y. Xiong and X. Cheng, "Prognostic and warning system for power-electronic modules in electric, hybrid electric, and fuel-cell vehicles," *IEEE Transactions on Industrial Electronics*, vol. 55, June 2008.
- [3] Van Wyk, J.D.; Lee, F.C., 'On a Future for Power Electronics', *Emerging and Selected Topics in Power Electronics, IEEE Journal of*, vol.1, no.2, pp. 59-72, Jun. 2013.
- [4] M. Pecht, and F. Nash, "Predicting the reliability of electronic equipment," *Proceedings of the IEEE*, vol. 82, no. 7, pp. 992-1004, 1994.
- [5] C. Y. Yin, H. Lu, M. Musallam, C. Bailey and C.M. Johnson, "Prognostic Reliability Analysis of Power Electronics Modules", *International Journal of Performability Engineering*, vol.6, pp.513-524, 2010.
- [6] Song, Y., Wang, B., "Survey on Reliability of Power Electronic Systems," *Power Electronics IEEE Transactions*, vol.28, no.1, pp.591-604, Jan. 2013 doi: 10.1109/TPEL.2012.2192503.
- [7] A. Dasgupta, D. Barker, and M. Pecht, "Reliability prediction of electronic packages," *Journal of the Institute of Environmental Sciences*, vol. 33, no. 3, pp. 36-45, 1990.
- [8] H. Ye, M. Lin, C. Basaran, "Failure Modes and FEM Analysis of Power Electronics Packaging," *Journal of Finite Elements in Analysis and Design*, vol. 38, pp. 601 – 612, 2002.
- [9] N. Vichare, P. Rodgers, V. Eveloy and M. Pecht, "Environment and usage monitoring of electronic products for health (reliability) assessment and product design," *IEEE Workshop and Accelerated Stress Testing & Reliability*, Austin, 2005.
- [10] H. Lu, T. Tilford, C. Bailey and D.R. Newcombe, "Lifetime prediction for power electronics module substrate mount-down solder interconnect," *Proceeding of the International Symposium on High Density Packaging and Microsystem Integration*, China, 2007, pp. 40-45.
- [11] Hegazy, O., Barrero, R., Van Mierlo, J., Lataire, P., Omar, N., Coosemans, T., "An Advanced Power Electronics Interface for Electric Vehicles Applications," *Power Electronics IEEE Transactions*, vol.28, no.12, pp. 5508-5521, Dec. 2013.
- [12] Boyi Yang, Jun Wang; Shuming Xu; Korec, J.; Shen, Z.J.; , "Advanced Low-Voltage Power MOSFET Technology for Power Supply in Package Applications," *Power Electronics IEEE Transactions*, vol.28, no.9, pp. 4202-4215, Sep. 2013.
- [13] Testa, A.; De Caro, S.; Russo, S.; , "A Reliability Model for Power MOSFETs Working in Avalanche Mode Based on an Experimental Temperature Distribution Analysis," *Power Electronics, IEEE Transactions*, vol.27, no.6, pp.3093-3100, June 2012.
- [14] K. Feldman, T. Jazouli, and P. Sandborn, "A methodology for determining the return on investment associated with prognostics and health management," *IEEE Trans. on Reliability*, vol. 58, no. 2, pp. 305-316, June 2009.
- [15] G. Haddad, P.A. Sandborn, T. Jazouli, M.G. Pecht, B. Foucher and V. Rouet, "Guaranteeing high availability of wind turbines," *ESREL Conference*, Troyes, France, September 18-22, 2011.
- [16] A. Hamidi, N. Beck, K. Thomas, and E. Herr, "Reliability and lifetime evaluation of different wire bonding technologies for high power IGBT modules," *Microelectronics Reliability*, vol. 39, pp. 1153-1158, 1999.
- [17] J.L. Fock-Sui-Too, B. Chauchat, P. Austin, M. Mermet-Guyennet, and R. Meuret, "Performance and reliability testing of modern IGBT devices under typical operating conditions of aeronautic applications", *Microelectronics Reliability*, vol. 48, pp.1453-1458, 2008.
- [18] F. P. McCluskey, D. Das, J. Jordan, L. Condra, T. Torri, J. Fink and R. Grzybowski, "Packaging of electronics for high temperature environments," *International Journal of Microcircuits and Electronic Packaging*, vol. 20, no. 3, p. 409. Third Quarter 1998. *Adapted from Proceedings of the Int'l Electronics Packaging Society Conference*, held in Austin, TX, Sep 29- Oct 1, pp. 143 – 155, 1996.
- [19] G. Khatibi, M. Lederer, B. Weiss, T. Licht, J. Bernardi, and H. Danninger, "Accelerated mechanical fatigue testing and lifetime of interconnects in microelectronics," *Proc. Eng.*, vol. 2, no. 1, pp. 511–519, Apr. 2010.
- [20] S. Manson, *Thermal Stress and Low-Cycle Fatigue*, McGraw-Hill, New York, 1966.
- [21] M. C. Shaw, D. B. Marshall, B. J. Dalgleish, M. S. Dadkhah, M. Y. He, and A. G. Evans, "Fatigue crack growth and stress redistribution at interfaces," *Acta Metall. Mater.*, vol. 42, no. 12, pp. 4091–4099, Dec. 1994.
- [22] Military Handbook for Reliability Prediction of Electronic Equipment, MIL-HDBK 217, version A, U.S Department of Defense (DoD), Washington DC, 1965.
- [23] Telcordia Technologies, Special Report SR-32, "Reliability Prediction Procedure for Electronic Equipment," issue 1, Telcordia Customer Service. Piscataway, NJ, 2001.
- [24] W. Denson, "A Tutorial: PRISM," *RAC Journal*, pp. 1 -6, 1999.
- [25] FIDES Group, FIDES Guide, "Reliability Methodology for Electronic Systems," Issue A, 2004.
- [26] M. Cushing, D. Morton, T. Stadterman, and A. Malhotra, "Comparison of electronics reliability assessment approaches," *IEEE Transaction on Reliability*, vol. 42, no. 4, pp. 542-546, 1993.
- [27] N. Patil et al., "A Prognostic approach for non-punch through and field stop IGBTs," *Microelectronics Reliability*, vol. 52, issue 3, pp. 482-488, March 2012.
- [28] G. Niu, S. Singh, S.W. Holland and M. Pecht, "Health monitoring of electronic products based on Mahalanobis distance and Weibull decision metrics," *Microelectronics Reliability*, vol. 51, Issue 2, pp. 279-284, February 2011.
- [29] Ji, B.; Pickert, V.; Cao, W.; Zahawi, B.; , "In Situ Diagnostics and Prognostics of Wire Bonding Faults in IGBT Modules for Electric Vehicle Drives," *Power Electronics IEEE Transactions*, vol.28, no.12, pp. 5568-5577, Dec. 2013.
- [30] N. Vichare and M. Pecht, "Prognostics and health management of electronics," *IEEE Transactions on Components and Packaging Technologies*, vol. 29, no. 1, March 2006.
- [31] P. Lall, M. Islam, M. Rahim and J. Suhling, "Prognostics and health management of electronic packaging," *IEEE Trans. Components and Packaging Technologies*, vol. 29, no. 3, pp. 666-675, 2006.
- [32] Oukaour et al., "Ageing defect detection on IGBT power modules by artificial training methods based on pattern recognition," *Microelectronics Reliability*, 2011.
- [33] Y. Han and Y. H. Song, "Condition monitoring techniques for electrical equipment—a literature survey," *IEEE Trans. Power Del.*, vol. 18, no. 1, pp. 4–13, Jan. 2003.
- [34] S. Yang, D. Xiang, et al., "Condition Monitoring for Device Reliability in Power Electronic Converters: A Review," *Power Electronics IEEE Transactions*, vol. 25, Issue: 11, pp. 2734 – 2752, Nov. 2010.
- [35] M. Pecht, B. Tuchband, N. Vichare, Q. Ying, "Prognostics and Health Monitoring of Electronics," *Proceedings of Thermal, Mechanical and*

- MultiPhysics Simulation Experiments in Microelectronics and Micro-Systems*, 2007.
- [36] S. Mishra and et al, "In-situ Sensors for Product Reliability Monitoring," *Proceedings of the SPIE*, vol. 4755, pp. 10-19, 2002.
- [37] N. Patil, D. Das, K. Goebel, and M. Pecht, "Identification of failure precursor parameters for insulated gate bipolar transistors (IGBT's)," *IEEE International Conference on Prognostics and Health Management (PHM)*, Denver, CO, USA, October 6-9, 2008.
- [38] C. Bailey, H. Lu, C. Yin, S. Ridout, "Predictive reliability, prognostics and risk assessment for power modules," *Proceeding of the CIPS conference*, Germany, 2008, pp.19-25.
- [39] B. W. Ricks and O. J. Mengshoel, "Methods for probabilistic fault Diagnosis: An electrical power system case study," *Proc. of the First Annual Conference of the Prognostics and Health Management Society (PHM-09)*, San Diego, CA, 27 September – 1 October, 2009.
- [40] H. Wang, M. Liserre, F. Blaabjerg, P. de Place Rimmen, J. B. Jacobsen, T. Kvisgaard, and J. Landkildehus "Transitioning to Physics-of-Failure as a Reliability Driver in Power Electronics", *Emerging and Selected Topics in Power Electronics, IEEE Journal of*, vol.2, no.1, pp. 97-114, Mar. 2014.
- [41] M. Pecht, A. Dasgupta, D. Barker, D. and C. Leonard, "The reliability physics approach to failure prediction modeling," *International Journal of Quality and Reliability Engineering*, vol. 6, no. 4, pp. 267-274, 1990.
- [42] J. Bielen, J.-J. Gommans, and F. Theunis, "Prediction of high cycle fatigue in aluminium bond wires: A physics of failure approach combining experiments and multi-physics simulations," in *Proc. 7th Int. Conf. EuroSime*, Como, Italy, 2006, pp. 1-7.
- [43] M. Pecht and J. Gu, "Physics-of-failure based prognostics for electronic products," *Transactions of the Institute of Measurement and Control*, vol. 31, pp. 309-322, 2009.
- [44] H. Lu, W.S. Loh, T. Tilford, C. Bailey, C.M. Johnson, "Reliability of power electronic modules," *Proceedings of IPACK2007*, ASME InterPACK '07, July 8-12, 2007.
- [45] IEEE Standard 1413-2002. IEEE Guide for selecting and using reliability predictions based on IEEE 1413. IEEE, NY; 2002.
- [46] M. Pecht, A. Dasgupta, "Physics of failure: an approach to reliable product development. *J Inst Environ. Sci.*, vol 38, pp. 30-34, 1995.
- [47] F. P. McCluskey, E.B. Hakim, J. Fink, A. Fowler, and M. Pecht, "Reliability assessment of electronic components exposed to long-term non-operating conditions," *IEEE Transactions on Components, Packaging and Manufacturing Technology*, vol. 21, No. 2, part A, pp. 352-360, June 1998.
- [48] N. Patil, D. Das, C. Yin, H. Lu, C. Bailey, M. Pecht, "A Fusion approach to IGBT power module prognostics," *13th International conference on thermal, mechanical and multi-physics simulation and experiments in microelectronics and microsystems (EuroSime)*, Delft, Netherlands, 2009. pp. 215-220.
- [49] M. Musallam and C.M. Johnson, "Real-time compact thermal models for health management of power electronics," *IEEE Power Electronics Transactions*, vol.25, issue 6, pp. 1416 – 1425, June 2010.
- [50] Standard Practices for Cycle Counting in Fatigue Analysis, ASTM E1049-85(2011) e1, doi: 10.1520/E1049-85R11E01.
- [51] S. D. Downing, D. F. Socie, "Simple rainflow counting algorithms," *International Journal of Fatigue*, Volume 4, Issue 1, January, (1982), pp.31-40.
- [52] D. Chamund, C. Rout, "Reliability of high power bipolar devices," *Application Notes - AN 5945*, October 2009 [online]. Available: <http://www.dynex-powersemiconductors.com/application-notes>
- [53] Coffin Jr L. Met. Eng. Q., 1963, pp.15-24.
- [54] L. F. Coffin, Jr., "A study of the effects of cyclic thermal stresses on a ductile metal," *Trans. ASME*, vol. 76, no. 6, pp. 931-950, 1954.
- [55] S. S. Manson, "Behaviour of materials under conditions of thermal stress," NACA, Washington, DC, Rep. No. 1170, 1954.
- [56] Miner, M.A., "Cumulative Damage in Fatigue", *Journal of Applied Mechanics*, Vo. 67, pag. A159-A164, 1945
- [57] S. Suresh, *Fatigue of Materials*, Cambridge University, Press (1991), p.133
- [58] Fatemi A., Yang L., "Cumulative fatigue damage and life prediction theories: a survey of the state of the art for homogeneous materials", *Int. J. of Fatigue*, Vo. 20, n° 1, pp.9-34, 1998.
- [59] A.T. Bryant, L. Liqing, E. Santi, P.R. Palmer, J.L. Hudgins, "Physical Modeling of Fast p-i-n Diodes with Carrier Lifetime Zoning, Part I: Device Model," *Power Electronics, IEEE Transactions*, vol. 23, Issue 1, pp. 189-197, January 2008.
- [60] A.T. Bryant, P.A. Mawby, P.R. Palmer, E. Santi, J.L. Hudgins, "Exploration of Power Device Reliability Using Compact Device Models and Fast Electrothermal Simulation," *IEEE Industry Applications Society*, October 2007.
- [61] M. Musallam, C. M. Johnson, "Extraction of Efficient Thermal Models for Life Limiting Interfaces in Power Modules", *CIPS 2008 – the 5th International Conference on Integrated Power Electronics Systems*, March, 11-13, 2008, Nuremberg, Germany.
- [62] Flotherm, [Online]. Available: <http://www.flomerics.com/>
- [63] Matlab, [Online]. Available <http://www.mathworks.com>
- [64] DspaceSystems, [Online]. Available: <http://www.dspace.com/en/ltld/home.cfm>
- [65] Anthes, R.J., "Modified Rainflow Counting Keeping the Load Sequence", *International Journal of Fatigue*, 1997, pp.529-535.
- [66] I. Rychlik, A New Definition of the Rainflow Cycle Counting Method, *Int. J. Fatigue* 9:2, (1987), pp. 119-121.
- [67] U. Scheuermann, U. Hecht, 'Power Cycling Lifetime of Advanced Power Modules for Different Temperature Swings', *Proc. PCIM, PE4.5*, pp. 59-64, Nürnberg, 2002.
- [68] M Musallam, M Johnson, "An Efficient Implementation of the Rainflow Counting Algorithm for Life Consumption Estimation," *IEEE Reliability Transactions*, vol. 61, Issue 4, pp. 978 – 986, December 2012.
- [69] H. Lu, C. Bailey and C. Yin, "Design for reliability of power electronics modules," *Microelectronics Reliability*, vol. 49, pp. 1250-1255, 2009.
- [70] C. Y. Yin, H. Lu, M. Musallam, C. Bailey, M. Johnson, "A Physics-of-failure based Prognostic Method for Power Modules", *Proceedings of the 10th International Conference on Electronics Packaging Technology*, Singapore, (2008), pp. 1190-1195.
- [71] C. Bailey, T. Tilford, H. Lu "Reliability analysis for power electronics modules," *30th International spring seminar on electronics technology, ISSE2007*, Cluj Napoca, Romania, 2007.
- [72] H. Lu, W-S. Loh, C. Bailey, M. Johnson, "Computer modelling analysis of the globtop's effects on aluminium," *IEEE Electronics System Integration Conference (ESTC)*, Greenwich, London, UK, 2008, pp. 1369-1375.
- [73] Yang, L, Agyakwa, PA and Johnson, CM, 'A Time-Domain Physics-Of-Failure Model for the Lifetime Prediction of Wire Bond Interconnects', *Microelectronics Reliability*. 51(9-11), 1882-1886, 2011.
- [74] T. Wernicke, A. Middendorf, S. Dieckerhoff, S. Guttowski, H. Reichl, "Test system for the reliability management of power modules," *Proceeding of the CIPS conference*, Germany; 2008. pp. 49 –53.
- [75] M. Alam, H. Lu, C. Bailey, "Fracture Mechanics Analysis of Cracks in Solder Joint Intermetallic Compounds," *IEEE Electronics System Integration Conference (ESTC)*, Greenwich, London, UK; 2008, pp. 757– 762.
- [76] C. Y. Yin, H. Lu, M. Musallam, C. Bailey, C. M. Johnson, "In-service Reliability Assessment of Solder Interconnect in Power Electronic Modules", *Proceedings of IEEE-Prognostics & System Health Management Conference*, 2010, Macau.
- [77] M Musallam, C Yin, C Bailey, M Johnson, " Application of coupled electro-thermal and physics-of-failure-based analysis to the design of accelerated life tests for power modules", *Elsevier Journal for Microelectronics Reliability*, Available online 27 September 2013.
- [78] R. Johnson, J. Evans, P. Jacobsen, J. Thompson, and M. Christopher, "The changing automotive environment: High-temperature electronics," *IEEE Trans. Electron. Packag. Manuf.*, vol. 27, no. 3, pp. 164-176, July 2004.
- [79] Z. Xu, M. Li, F. Wang, and Z. Liang, "Investigation of Si IGBT operation at 200 °C for traction applications," *IEEE Trans. Power Electron.*, vol. 28, no. 5, pp. 2604-2615, May 2013.
- [80] H. Zhang, L. Tolbert, and B. Ozpineci, "Impact of SiC devices on hybrid electric and plug-in hybrid electric vehicles," *IEEE Trans. Ind. Appl.*, vol. 47, no. 2, pp. 912-921, Mar./Apr. 2011.
- [81] H. Berg, E. Wolfgang, "Advanced IGBT modules for railway traction applications: Reliability testing," *Microelectronics Reliability*, vol.38, Issues 6-8, pp. 1319-1323, June 1998.
- [82] M Musallam, M Johnson, C Yin, H Lu and C Bailey, M. Mermet-Guyennet, 'Real-Time Life Consumption Power Modules Prognosis Using On-line Rainflow Algorithm in Metro Applications' *IEEE Energy Conversion Congress and EXPO. (ECCE)*, 2010, Atlanta, Georgia, USA.
- [83] F. Blaabjerg, K. Ma, 'Future on Power Electronics for Wind Turbine Systems', *Emerging and Selected Topics in Power Electronics, IEEE Journal*, vol.1, no.3, pp. 139-152, Sep. 2013
- [84] P. J. Tavner, F. Spinato, G. J. W. van Bussel, and E. Koutoulakos, "Reliability of wind turbine subassemblies," *IET Renewable Power Generation*, vol. 3, no. 4, pp. 387-401, Dec. 2009.
- [85] Y. Zhao, C. Wei, Z. Zhang, and W. Qiao, "A Review on Position/Speed Sensorless Control for Permanent-Magnet Synchronous Machine-Based Wind Energy Conversion Systems", *Emerging and Selected Topics in Power Electronics, IEEE Journal of*, vol.1, no.4, pp. 203-216, Dec. 2013

- [86] C. Abbey, and G. Joos, "A doubly-fed induction machine and energy storage for wind power applications," in *IEEE PESC*, Aachen, Germany, 2004.
- [87] A. Mesemanolis, C. Mademlis, and I. Kioskeridis, "Optimal Efficiency Control Strategy in Wind Energy Conversion System With Induction Generator", *Emerging and Selected Topics in Power Electronics, IEEE Journal of*, vol.1, no.4, pp. 238-246, Dec. 2013.
- [88] M. Musallam, C. M. Johnson, 'Real-time Physics of Failure Based Estimation of Life Consumption in Power Electronic Modules', *EPE Joint Wind Energy and T&D Chapters Seminar*, The Norwegian University of Science and Technology, NTNU, Trondheim, Norway, 9-11 May 2011.