

**The molecular mechanisms of vernalization induced
flowering in temperate cereals.**

Aaron Geoffrey Greenup

February 2011

A thesis submitted for the degree of Doctor of Philosophy of the
Australian National University



THE AUSTRALIAN NATIONAL UNIVERSITY
LIBRARY

THE AUSTRALIAN NATIONAL UNIVERSITY

LIBRARY

THE AUSTRALIAN NATIONAL UNIVERSITY
LIBRARY

Declaration

I declare that the material contained in this thesis is entirely my own work, except where indicated below.

Chapter 1 was originally published in the international plant science journal *Annals of Botany*. It was co-authored by Dr. James Peacock, Dr. Elizabeth Dennis and Dr. Ben Trevaskis (supervisor). Dr. Trevaskis provided ideas and helped to write the manuscript, while Dr. Peacock and Dr. Dennis provided suggestions for the improvement of the manuscript prior to publication. I have since updated the contents of the manuscript for the purposes of this thesis.

Chapter 2 has been accepted for publication in the international journal *PLoS ONE*. It was co-authored by Dr. Shahryar Sasani, Dr. Sandra Oliver, Dr. Sally Walford, Dr. Anthony Millar (supervisor) and Dr. Ben Trevaskis (supervisor). Dr. Walford carried out the Principal Components Analysis (PCA), while Dr. Sasani and Dr. Oliver contributed to the design of the microarray experiments. Dr. Millar provided suggestions for the improvement of the manuscript prior to submission. Dr. Trevaskis carried out some of the statistical analysis of the microarray data and helped to write the manuscript.

Chapter 3 was published in the international plant science journal *Plant Physiology*. It was co-authored by Dr. Shahryar Sasani, Dr. Sandra Oliver, Dr. Mark Talbot, Dr. Elizabeth Dennis, Dr. Megan Hemming and Dr. Ben Trevaskis (supervisor). Dr. Sasani, Dr. Hemming and Dr. Dennis provided input into the experimental design and improvement of the manuscript. Dr. Sandra Oliver performed the Chromatin Immunoprecipitation (ChIP) experiments and Dr. Talbot took the electron microscopy images. Dr. Trevaskis provided the transgenic plants and helped write the manuscript.

Chapter 4. Dr Million Tadege provided full length sequences for both barley *SOCI-like* genes and the seeds for the transgenic plants. Dr Ben Trevaskis (supervisor), Dr. Peter Chandler and Dr. Steve Swain have been involved in helpful discussions regarding the significance of various findings.

With the exception of the above contributions, this thesis is entirely my own work.

Signed:

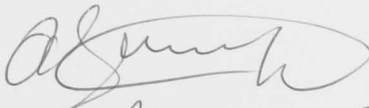

AARON GREENUP.

Acknowledgements

So many people have guided and helped me during the course of my studies, but it would be impossible to name and thank every single one of them here. Instead, I would like to acknowledge the support of all my friends and colleagues from CSIRO Plant Industry, particularly those from Program V and X. I had a great time during my time at Plant Industry, which was due in large to the people that work there. However, I would like to give a special thank you to a number of people who have been extremely supportive and generous with their time and wisdom.

I would like to thank Jenny Thistleton for her friendship during my time at Plant Industry. At times when I thought everything was going wrong in my life and that I'd never be able to finish, a coffee with Jenny always helped to put things back into perspective (Thanks Jenny).

Next I would like to thank the cereal flowering group (Sandra Stops, Sarah Feig, Megan Hemming, Sandra Oliver and my supervisor Ben Trevaskis). Without these people I wouldn't have achieved much during my PhD. Whether it was help with harvesting and threshing or advice about experimental design everyone was always willing to provide a helping hand and I'm very thankful for it.

I'd also like to give a special thank you to Iain Wilson, Sandra Oliver, Tony Millar and Ben Trevaskis for their professional and personal advice over the past few years.

Finally and most importantly I would like to thank my wife Kerry. I am certain that I would never have gotten to this point in my life without the sacrifices and loving support of Kerry. Although I spent the last 7 years as a student and at times this put extreme pressure on our relationship, Kerry always supported me. Whether it was helping me water plants, counting final leaf numbers or listening to me drone on and on during practice talks, Kerry was always there to help me out. So now that my PhD is coming to a close I'm looking to spending more weekends and evenings with you.

Abstract

Plants coordinate development with environmental cues to ensure flowering occurs under optimal seasonal conditions. Many plants from temperate regions only flower after exposure to prolonged cold: vernalization. While the molecular mechanisms of the vernalization response have been studied extensively in the model plant *Arabidopsis*, this seasonal flowering response has probably evolved independently in other plants. For instance, no homologues of *FLOWER LOCUS C (FLC)*, the gene central to the vernalization response in *Arabidopsis*, have been found in economically important crops such as barley and wheat. Instead *VERNALIZATION1 (VRN1)* is central to the vernalization response in these plants. This highlights a need to study the vernalization response directly in cereal crop species.

Previous studies have identified *VRN1* as a master regulator of the vernalization response in cereals, but the extent to which other genes contribute is unclear. To identify genes that are potentially involved in regulating the vernalization response the Barley1 Affymetrix chip was used to compare gene expression in barley seedlings during short or prolonged cold treatments. Additionally, gene expression was assayed when plants were shifted to normal growth temperatures following prolonged cold treatment. This identified genes that show lasting changes in transcriptional activity, which might contribute to vernalization-induced flowering. Only a small group of genes showed a lasting change in activity when plants were shifted to warm conditions following prolonged cold. These included *VRN1* and another MADS box gene, *ODDSOC2 (OS2)*.

OS2 belongs to a group of MADS box genes only found in grasses. Expression analysis showed that *OS2* is down-regulated by cold and that long term repression of *OS2* is dependent on *VRN1*. Overexpression of *OS2* in barley delayed flowering and caused dwarfing. These phenotypes could be due to the down-regulation of *FLOWERING PROMOTING FACTOR1 (FPF1)*-like genes. In *Arabidopsis* *FPF1* promotes flowering and elongation. Thus down-regulation of *OS2* likely contributes to the acceleration of flowering through the de-repression of *FPF1*-like genes as daylength increases in spring.

To determine if any components of the vernalization response pathway are conserved between *Arabidopsis* and temperate cereals, barley homologues of the *Arabidopsis* MADS box gene *SUPPRESSOR OF OVEREXPRESSION OF CONSTANS 1 (SOC1)* were identified and characterised. In *Arabidopsis* *SOC1*

promotes flowering and is positively regulated by vernalization, long-days, and development. Similar to *SOC1*, the expression of barley *SOC1-like* genes increases during development. Unlike Arabidopsis, the expression of a barley *SOC1-like* gene, *HvSOC1-like1* was similar regardless of daylength suggesting that photoperiod does not regulate the expression of these genes. The regulation of *HvSOC1-like* genes by vernalization is also different. The expression of *HvSOC1-like* genes was lower in the leaves and crown tissue of vernalized plants versus non-vernalized plants. Overexpression of one of the barley *SOC1-like* genes, *HvSOC1-like1*, delayed flowering and caused dwarfing in barley plants. The phenotypes of these plants are different to what has been found in previous overexpression studies for a number of different *SOC1-like* genes. Overall these data suggest that cereal *SOC1-like* genes have evolved differently and have different regulatory functions than *SOC1* from Arabidopsis

Overall the findings from this thesis extend our understanding of the vernalization response in temperate cereals and highlight the difference of how this seasonal flowering response is regulated in temperate cereals and Arabidopsis. Since *VRNI* is one of only a limited number of genes that initiates flowering in temperate cereals, understanding how *VRNI* is regulated and identifying the targets of *VRNI* will be of critical importance to understanding the mechanisms of seasonal flowering responses in these plants.

Table of Contents

Declaration	ii
Acknowledgements	iii
Abstract	iv
Abbreviations	ix
Chapter 1: Introduction	
Abstract	2
Seasonal flowering responses	3
Seasonal control of flowering in Arabidopsis	3
The daylength flowering-response pathway of Arabidopsis	3
The vernalization flowering-response pathway of Arabidopsis	7
The thermo-sensitive flowering response pathway	8
Are the roles of Arabidopsis flowering time genes conserved in cereals?	9
The daylength response of rice; a short-day grass	10
The daylength response in temperate cereals; long-day grasses	12
The vernalization response of temperate cereals	15
The thermo-sensitive flowering response of temperate cereals	13
How useful is Arabidopsis as a model for understanding the regulation of flowering time in cereals and other plants?	15
Conclusion	16
Objectives / Outline of Thesis	16
Chapter 2: Transcriptome analysis of the vernalization response in barley (<i>Hordeum vulgare</i>) seedlings	
Abstract	30
Introduction	31
Results	33
K-means cluster analysis	37
Vernalization-responsive genes	40
Discussion	44

Materials and methods	47
Supplemental Data	56

*Supplemental Tables 1-11 can be found in the attached CD

Chapter 3: *ODDSOC2* is a MADS box floral repressor that is down-regulated by vernalization in temperate cereals

Abstract	58
Introduction	59
Results	
<i>ODDSOC2</i> is a truncated MADS box gene found in cereals and related grasses	60
<i>HvOS2</i> is repressed by vernalization	65
The 5' UTR of <i>HvOS2</i> is not enriched for H3K27 trimethylation	65
Expression of <i>HvVRN1</i> is associated with down-regulation of <i>HvOS2</i>	68
Constitutive over-expression of <i>HvOS2</i> delays flowering and inhibits leaf and stem elongation	71
Constitutive over-expression of <i>HvOS2</i> down-regulates barley homologues of <i>Floral Promoting Factor 1</i>	74
<i>FPFI-like</i> genes are regulated by vernalization and daylength in barley	74
Discussion	77
Materials and Methods	82
Supplemental Data	93

Chapter 4: Characterisation of barley (*Hordeum vulgare*) *SOCI-like* genes

Abstract	112
Introduction	113
Results	
Chromosomal location and comparisons with rice and Brachypodium	115
Regulation of <i>HvSOCI-like</i> genes	118
Constitutive over-expression of <i>HvSOCI-like1</i> causes dwarfing and delays flowering	121
Discussion	125
Materials and Methods	129
Supplemental Data	137

Chapter 5: General discussion and conclusions

VRN1 and the vernalization response 147

Implications for future research 149

How is *VRN1* regulated? 149

VRN1 regulatory targets 149

Beyond *VRN1*: the importance of genes other than *VRN1* 150

Emerging genetic resources and the future of cereal biology 151

Concluding remarks 152

Abbreviations

<i>20ox2</i>	<i>20-oxidase 2</i>
<i>AGL</i>	<i>AGAMOUS LIKE</i>
<i>AP</i>	<i>APETALA</i>
<i>BM</i>	<i>BARLEY MADS</i>
<i>CBF</i>	<i>C-REPEAT BINDING FACTOR</i>
<i>CCT</i>	<i>CO, CO-like and TIMING OF CAB1 EXPRESSION 1</i>
<i>ChIP</i>	<i>Chromatin Immuno-precipitation</i>
<i>CO</i>	<i>CONSTANS</i>
<i>COR14B</i>	<i>COLD REGULATED 14B</i>
<i>DHN5</i>	<i>DEHYDRIN5</i>
<i>Eps</i>	<i>Earliness per se</i>
<i>Ehd1</i>	<i>Early heading date 1</i>
<i>FLC</i>	<i>FLOWERING LOCUS C</i>
<i>FLD</i>	<i>FLOWERING LOCUS D</i>
<i>FLN</i>	<i>Final Leaf Number</i>
<i>FPF</i>	<i>FLOWERING PROMOTING FACTOR</i>
<i>FR</i>	<i>FROST TOLERANCE</i>
<i>FRI</i>	<i>FRIGIDA</i>
<i>FT</i>	<i>FLOWERING LOCUS T</i>
<i>FUL</i>	<i>FRUITFULL</i>
<i>Ghd</i>	<i>Grain number, plant height and heading date</i>
<i>GI</i>	<i>GIGANTEA</i>
<i>HAP</i>	<i>HEME ACTIVATING PROTEIN</i>
<i>Hd1</i>	<i>Heading date 1</i>
<i>Hd3a</i>	<i>Heading date 3a</i>
<i>H3K27me3</i>	<i>Tri-methylation at Lysine 27 of the Histone 3 tail</i>
<i>Id1</i>	<i>INDETERMINATE1</i>
<i>KOI</i>	<i>ent-kaurene oxidase</i>
<i>KOAl</i>	<i>ent-kaurenoic acid oxidase 1</i>
<i>LD</i>	<i>LUMINIDEPENDENS</i>

Abbreviations

miR	microRNA
<i>OS</i>	<i>ODDSOC</i>
PCA	Principal Component Analysis
PCR	Polymerase Chain Reaction
PHD	Plant Homeodomain
<i>PPD1</i>	<i>PHOTOPERIOD1</i>
PRC2	Polycomb Repression Complex 2
qRT-PCR	quantitative Reverse Transcriptase - PCR
<i>PRR</i>	<i>PSEUDO RESPONSE REGULATOR</i>
<i>RFT1</i>	<i>Rice FT1</i>
RMA	Robust Multichip Analysis
<i>rsh1</i>	<i>RNase S-like homologue 1</i>
<i>SOC1</i>	<i>SUPPRESSOR OF OVEREXPRESSION OF CONSTANS 1</i>
<i>SPL</i>	<i>SQUAMOSA PROMOTER BINDING PROTEIN-LIKE</i>
<i>SVP</i>	<i>SHORT VEGETATIVE PHASE</i>
<i>TOC1</i>	<i>TIMING OF CAB1 EXPRESSION 1</i>
<i>VIN3</i>	<i>VERNALIZATION INSENSITIVE3</i>
<i>VRN</i>	<i>VERNALIZATION</i>
<i>VRT</i>	<i>VEGETATIVE TO REPRODUCTIVE TRANSITION</i>
<i>WSC19</i>	<i>WHEAT COLD SPECIFIC 19</i>
<i>WSOC1</i>	<i>Wheat SOC1</i>

Chapter 1

Introduction

Literature Review: The molecular biology of seasonal flowering responses in Arabidopsis and the cereals, *Annals of Botany* **103**: 1165-1172 (2009)

Abstract

In *Arabidopsis* (*Arabidopsis thaliana*), *FLOWERING LOCUS T* (*FT*) and *FLOWERING LOCUS C* (*FLC*) play key roles in regulating seasonal flowering responses to synchronise flowering with optimal conditions. *FT* is a promoter of flowering activated by long-days and by warm conditions. *FLC* represses *FT* to delay flowering until plants experience winter. The identification of genes controlling flowering in cereals allows comparison of the molecular pathways controlling seasonal flowering responses in cereals with those of *Arabidopsis*. The role of *FT-like* genes appears to be conserved in *Arabidopsis* and cereals. *FT-like* genes trigger flowering in response to short days in rice or long-days in temperate cereals, such as wheat (*Triticum aestivum*) and barley (*Hordeum vulgare*). Many varieties of wheat and barley require vernalization to flower but *FLC-like* genes have not been identified in cereals. Instead, *VERNALIZATION2* (*VRN2*) inhibits long-day induction of *FT-like1* (*FT1*) prior to winter. The MADS box gene, *VERNALIZATION1* (*VRN1*), is activated by low-temperatures during winter to repress *VRN2* and to allow the long-day response to occur in spring. In rice (*Oryza sativa*) a *VRN2-like* gene *Ghd7*, which influences grain number, plant height and heading date, represses the *FT-like* gene *Heading date 3a* (*Hd3a*) in long-days suggesting a broader role for *VRN2-like* genes in regulating daylength responses in cereals. Other genes, including *Early heading date* (*Ehd1*), *Oryza sativa MADS51* (*OsMADS51*) and *INDETERMINATE1* (*OsID1*) up-regulate *Hd3a* in short days. These genes might account for the different daylength response of rice compared to the temperate cereals. No genes homologous to *VRN2*, *Ehd1*, *OsID1* or *OsMADS51* occur in *Arabidopsis*. It seems that different genes regulate *FT* orthologues to elicit seasonal flowering responses in *Arabidopsis* and the cereals. This highlights the need for more detailed study into the molecular basis of seasonal flowering responses in cereal crops or in closely related model plants such as *Brachypodium distachyon*.

Seasonal flowering responses.

Plants coordinate flowering with optimal seasonal conditions to maximize reproductive success. In tropical regions many plants flower during the cooler seasons of the year to avoid the extreme heat of summer. Conversely, in temperate regions many plants flower during spring to avoid damage to floral organs by freezing winter temperatures. One mechanism by which plants synchronise flowering with optimal seasonal conditions is by sensing changes in daylength, or photoperiod. Many plants growing in the tropics flower as daylength decreases, whereas many plants from temperate regions flower in response to increasing daylength. Another important seasonal cue that regulates flowering time is temperature. In temperate regions warmer conditions can accelerate flowering in spring. Furthermore, many plants from temperate regions flower only after they experience an extended period of cold, or vernalization. This minimises the risk of frost damage to cold-sensitive reproductive organs. Often plants respond to a combination of daylength, vernalization and temperature to ensure optimal timing of flowering.

Studies of the model plant *Arabidopsis* (*Arabidopsis thaliana*) have provided insights into the molecular pathways controlling these seasonal flowering responses. Efforts are now being made to extend this understanding to other plants, including cereal crop species such as rice (*Oryza sativa*), wheat (*Triticum aestivum*) and barley (*Hordeum vulgare*). This chapter compares and contrasts the molecular pathways controlling seasonal flowering responses in *Arabidopsis* with those of cereals and related grasses.

Seasonal control of flowering in *Arabidopsis*.

In *Arabidopsis* three main seasonal flowering responses have been studied: the daylength response, the vernalization response and the thermo-sensitive flowering response.

The daylength flowering response pathway of *Arabidopsis*.

Flowering of *Arabidopsis* is accelerated by long-days. The key to the long-day flowering response is the activation of *FLOWERING LOCUS T* (*FT*) (Figure 1A) (reviewed in Imaizumi and Kay, 2006; Jaeger et al., 2006; Zeevaart, 2006; Turck et al., 2008). *FT* encodes a ‘mobile florigen’ (Kobayashi et al., 1999; Kardailsky et al., 1999; Corbesier et al., 2007). The *FT* gene is expressed in the leaves in long-days and the FT protein travels to the apex, where it interacts with another protein FD to activate the expression of genes that promote floral development, such as the MADS box gene *APETALLA1* (*API*) (Abe et al., 2005; Wigge et al.,

2005; Corbesier et al., 2007). This accelerates the transition towards reproductive development.

Expression of *FT* is activated by *CONSTANS* (*CO*) (Figure 1A) (Koorneef et al., 1991; Onouchi et al., 2000; An et al., 2004). *CO* mRNA is expressed with a diurnal rhythm, peaking in the late afternoon, and the *CO* protein is stabilised by light (Suarez-Lopez et al., 2001; Valverde et al., 2004). In long-days *CO* mRNA levels peak during daylight, where the *CO* protein is stable, enabling *CO* to induce *FT* expression (Valverde et al., 2004). This does not happen when days are short, where the peak in *CO* mRNA expression occurs in darkness, resulting in low *CO* stability (Valverde et al., 2004; Jang et al., 2008).

The *CO* protein consists of a zinc finger domain and a CCT domain (*CO*, *CO*-like and TIMING OF CAB1 EXPRESSION 1 (*TOC1*)) (Putterill et al., 1995; Robson et al., 2001). CCT domains are predicted to form a structure similar to the HEME ACTIVATING PROTEIN2 protein (*HAP2*) of yeast (McNabb et al., 1995; Wenkel et al., 2006), which forms a complex with *HAP3* and *HAP5* to bind to the CCAAT box; a promoter motif required for up-regulation of many eukaryotic genes (McNabb et al., 1995). In *Arabidopsis*, *CO* interacts with members of the *AtHAP3* and *AtHAP5* families (also known as Nuclear Factor -YB and Nuclear Factor -YC respectively) (Wenkel et al., 2006; Siefers et al., 2009; Kumimoto et al., 2010). This interaction occurs through the CCT domain, and together these proteins might form different complexes to regulate expression of *FT* (Wenkel et al., 2006; Kumimoto et al., 2010). There is also evidence that suggests *CO* can bind directly to the promoter of *FT* (Tiwari et al., 2010). However, this study is limited to *in vitro* investigations and the functional significance of these interactions is unknown (Tiwari et al., 2010).

Genes encoding factors involved in the perception of daylight, or the control of the circadian clock, contribute to the proper regulation of the daylength response in *Arabidopsis* by controlling the activity of *CO* (Suarez-Lopez et al., 2001; Yanovsky and Kay, 2002; Valverde et al., 2004; Imaizumi et al., 2005). *GIGANTEA* (*GI*) expression is regulated by the circadian clock, and the *GI* protein binds to the promoter of the *CO* gene as part of a larger protein complex to promote expression of *CO* in the late afternoon (Sawa et al., 2007). Phytochromes and cryptochromes interact to control the stability of *CO* protein and to maximise the activity of the *CO* protein when high mRNA levels coincide with daylight (Valverde et al., 2004).

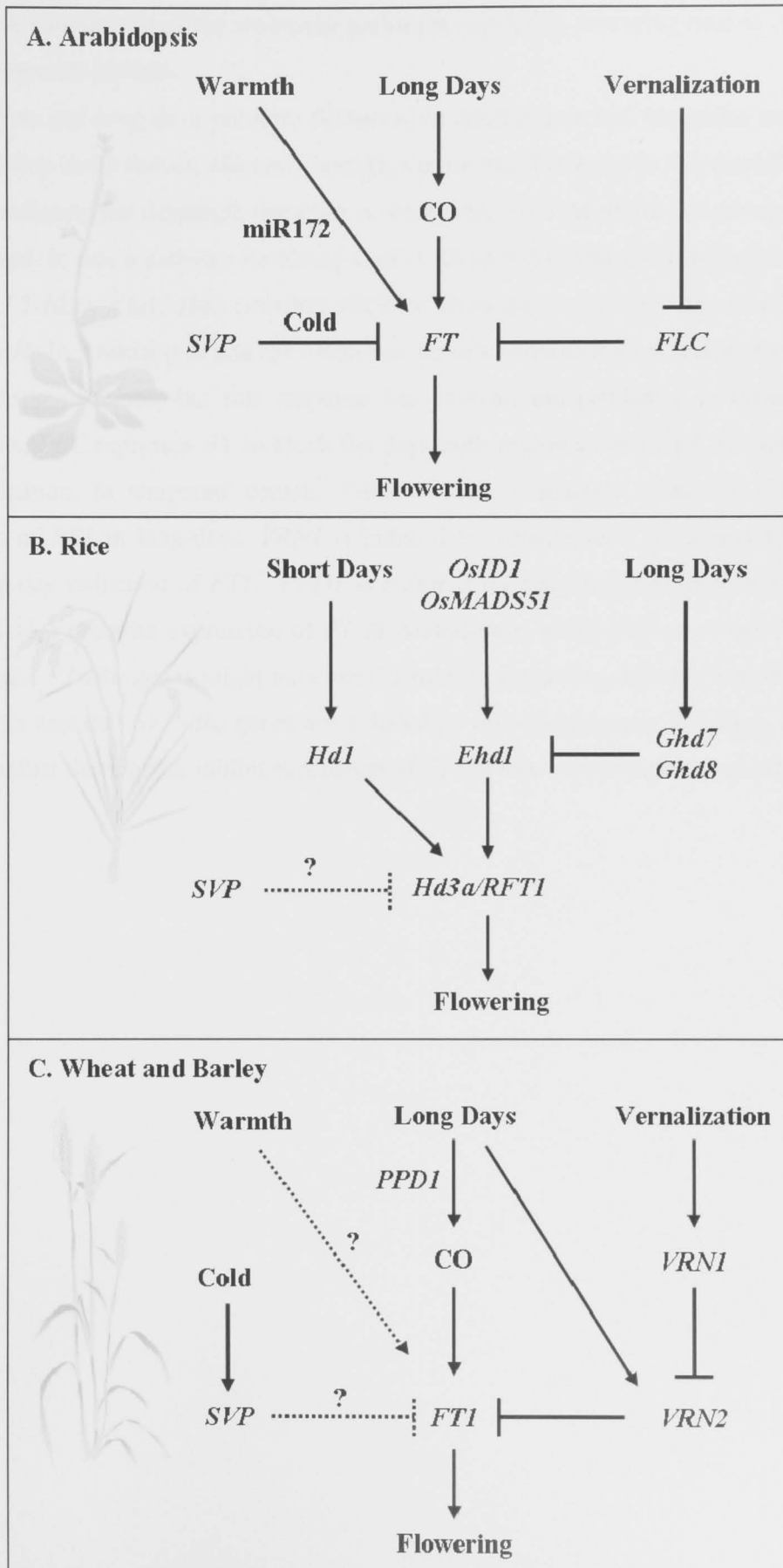

Figure 1. A comparison of the molecular pathways regulating flowering time in Arabidopsis, rice and temperate cereals.

Vernalization and long-days promote flowering in Arabidopsis and temperate cereals wheat and barley (top and bottom), whereas short days promotes flowering in rice (middle). The role of *FT* in mediating the daylength response is conserved. The role of the CO protein might also be conserved. In rice a pathway involving *OsIDI*, *OsMADS51* and *Ehd1* promotes expression of *Hd3a* (*FT-like*), while *Hd1* activates *Hd3a* in short days. In long-days *Ghd7* and *Ghd8* repress *Ehd1*. In Arabidopsis and the temperate cereals vernalization is required for the long-day flowering response, but this response has evolved independently in these plants. In Arabidopsis, *FLC* represses *FT* to block the daylength response until *FLC* is itself repressed by vernalization. In temperate cereals, *VRN2*, which is distantly related to *Ghd7*, blocks expression of *FT1* in long-days. *VRN1* is induced by vernalization to repress *VRN2* and to allow long-day induction of *FT1*. *PPD1* is required for long-day induction of *FT1*. Warm conditions also promote expression of *FT* in Arabidopsis, while *SVP* represses *FT* at lower temperatures. *FT-like* genes might have similar roles in regulating thermo-sensitive flowering responses in cereals. *SVP-like* genes are induced by low-temperatures in barley, but it is not known whether these genes inhibit expression of *FT1* at low temperatures in cereals.

The vernalization flowering response pathway of Arabidopsis.

Certain ecotypes of Arabidopsis require prolonged cold (also known as vernalization) to promote rapid flowering. In these ecotypes, flowering is delayed by the floral repressor *FLOWERING LOCUS C (FLC)* until plants are vernalized (Figure 1A) (Michaels and Amasino, 1999; Sheldon et al., 1999). *FLC* encodes a MADS box transcription factor that binds to sites within the *FT* gene to repress transcription and suppress the long-day flowering response (Michaels and Amasino, 1999; Sheldon et al., 1999; Michaels et al., 2005; Helliwell et al., 2006). *FLC* also represses a second floral promoter, *SUPPRESSOR OF OVER EXPRESSION OF CONSTANS 1 (SOC1)*, another MADS box transcription factor that acts downstream of *CO* (Hepworth et al., 2002; Michaels et al., 2005; Helliwell et al., 2006).

When plants are vernalized, expression of *FLC* decreases (Michaels and Amasino, 1999; Sheldon et al., 1999). This removes the repressive effect of *FLC* and allows long-day induction of *FT* and *SOC1*, and thus the long-day flowering response (Figure 1A) (Hepworth et al., 2002; Michaels et al., 2005). Vernalization-induced repression of *FLC* involves the Polycomb Repression Complex 2 (PRC2) (Shubert et al., 2006; Wood et al., 2006; De Lucia et al., 2008). This complex modifies histones in the chromatin at the *FLC* locus, and causes an increase in the level of tri-methylation at the lysine 27 residue of the histone 3 tail (H3K27me3) (Schubert et al., 2006; Sung et al., 2006; Greb et al., 2007; Finnegan and Dennis, 2007; De Lucia et al., 2008). H3K27me3 is a chromatin modification that in other organisms, such as in *Drosophila melongaster* and in mammals, is associated with long-term inactivation of gene expression (Cao and Zhang, 2004). Long term repression of *FLC* provides a memory of cold and allows plants to retain the ability to respond to long-days after winter until days lengthen during spring (Sheldon et al., 2000). A gene that is required for the PRC2 targeted repression of *FLC* is *VERNALIZATION INSENSITIVE3 (VIN3)*, which encodes a cold-induced Plant Homeodomain (PHD) protein that interacts with members of the PRC2 complex (Sung and Amasino, 2004; Wood et al., 2006; De Lucia et al., 2008).

FRIGIDA (FRI) is required to maintain high levels of *FLC* expression, and in doing so maintains the vernalization requirement (Koornneef et al., 1994; Lee et al., 1994; Johanson et al., 2000). Natural variation in *FRI* function is an important determinant of vernalization requirement in different ecotypes of Arabidopsis (Johanson et al., 2000). Other regulators of *FLC* include the so called autonomous pathway genes, which were originally defined by mutations that delay flowering irrespective of daylength (Reviewed by Simpson, 2004, and Marquardt et al., 2006). These include *LUMINIDEPENDENS (LD)*, *FCA*, *FY*, *FPA*, *FVE*, *FLOWERING LOCUS D (FLD)* and *FLK*. *FLD*, for example is a histone deacetylase that

normally reduces *FLC* expression levels (Sanda and Amasino, 1996; He et al., 2003). *FLD* mutants cause elevated *FLC* activity and delay flowering regardless of daylength (Sanda and Amasino, 1996).

The thermo-sensitive flowering response pathway.

While vernalization is a response to prolonged cold, flowering is also controlled by changes in ambient temperature. In *Arabidopsis* flowering is delayed at cooler temperatures (16°C compared to 23°C) (Blazquez et al., 2003). This flowering response might be important to delay flowering during early spring if temperatures are too low for optimal reproductive growth. *FT* expression is elevated at high growth temperatures (Blazquez et al., 2003) and plants that lack *FT* (*ft* mutants) show little acceleration of flowering at higher temperatures, so acceleration of flowering by higher growth temperatures is likely to be mediated through *FT* (Balasubramian et al., 2006). This does not require *CO*, so another *CO*-independent mechanism must induce *FT* in response to high temperatures (Balasubramian et al., 2006). Consistent with this hypothesis warmer growth conditions (27°C compared to 23°C) accelerate flowering in short days where *CO* is less active (Balasubramian et al., 2006).

The autonomous pathway genes *FCA* and *FVE* influence the effects of growth temperature on flowering time, and *fca* or *fve* mutants are late flowering at high growth temperatures (Blazquez et al., 2003; Balasubramian et al., 2006). This might be caused by elevated expression of the MADS box gene *SHORT VEGETATIVE PHASE* (*SVP*), as *svp* mutants suppress the delay of flowering at high temperatures in *fca* and *fve* mutants (Lee et al., 2007). Other pathways that control *FT* activity can influence the effect of growth temperature on flowering time. For example, the activities of light receptors, which influence entrainment of the clock or the activity of *CO* (and therefore *FT* expression levels) can also influence the thermo-sensitive flowering response (Guo et al., 1998; Blazquez et al., 2003). Similarly, two *PSEUDO RESPONSE REGULATOR* (*PRR*) genes, *PRR7* and *PRR9*, are required to entrain the circadian clock to both light and temperature and are likely to affect both daylength and temperature regulation of flowering time (Salome and McClung, 2005).

The *SVP* gene is required for delayed flowering in cool conditions (Lee et al., 2007). Expression of *FT* and *SOCI* is elevated in *svp* mutants, particularly at 16°C, and both genes are required for the early flowering phenotype of *svp* mutants (Lee et al., 2007). It has been shown that *SVP* interacts with *FLC*, and is required for *FLC* to bind and repress both *FT* and *SOCI* (Li et al., 2008). Conversely, *FLC* is also required for the action of *SVP* (Li et al., 2008). It seems that both these MADS box transcription factors are members of a protein

complex that represses *FT* and *SOC1* to regulate multiple seasonal flowering responses in *Arabidopsis*. In addition to affecting the thermo-sensitive flowering response, *svp* mutations dramatically reduce the vernalization requirement in *Arabidopsis* (Li et al., 2008).

Recent work by Lee et al. (2010) suggests *SVP* may also repress *FT* in cooler temperatures (16°C) through the down-regulation of microRNA172 (miR172). MiR172 is down-regulated at 16°C compared to 23°C, in a *SVP* dependent manner (Lee et al., 2010). *Arabidopsis* plants constitutively over-expressing miR172 flower earlier regardless of changes in ambient temperature or photoperiod (Jung et al., 2007; Lee et al., 2010). MiR172 promotes flowering through the de-repression of genes such as *FT* (Aukerman and Sakai, 2003; Mathieu et al., 2009). This occurs through the down-regulation a number of *APETALA2-like* (*AP2-like*) genes (Aukerman and Sakai, 2003; Mathieu et al., 2009). Interestingly, miR172 expression is regulated by *GI*, providing a direct link between the regulation of photoperiod flowering responses and thermo-sensitive flowering responses (Jung et al., 2007). It seems likely that circadian clock genes like *PRR7* and *PRR9* regulate thermo-sensitive flowering responses, at least in part, by modulating the expression of genes like *GI*.

Are the roles of *Arabidopsis* flowering time genes conserved in cereals?

Genes homologous to those that control seasonal flowering responses in *Arabidopsis* have been identified in cereal crop plants and related forage grasses. *FT-like* genes have been identified in wheat, barley, rice, maize (*Zea mays*) and *Lolium* (*Lolium perenne* or *L. temulentum*) (Kojima et al., 2002; King et al., 2006; Yan et al., 2006; Faure et al., 2007; Danilevskaya et al., 2008). *CO-like* genes have also been identified in these plants (Yano et al., 2000; Griffiths et al., 2003; Martin et al., 2004; Miller et al., 2008). Cereal homologues of *Arabidopsis* genes involved in the diurnal regulation of *CO* activity (*GI*, *TOC*, genes encoding phytochromes or cryptochrome) (Childs et al., 1997; Izawa et al., 2000; Hayama et al., 2002; Dunford et al., 2005), the photoperiod response (*SOC1* and *FD*) (Lee et al., 2004; Li and Dubcovsky, 2008), the vernalization or autonomous pathways (*VIN3*, *FCA*, *FY*) (Lee et al., 2005; Lu et al., 2006; Fu et al., 2007) and the thermo-sensitive flowering response (*SVP*) (Schmitz et al., 2000; Kane et al., 2005; Sentoku et al., 2005; Trevaskis et al., 2007; Fornara et al., 2008; Lee et al., 2008) have also been identified. As outlined below, there are differences in the way many of these genes function in monocot plants compared to *Arabidopsis*.

The daylength response of rice; a short-day grass.

Rice, one of the world's most important cereal crops, is generally grown in warmer climates. Unlike *Arabidopsis*, rice flowers preferentially under short days and does not require vernalization to flower, which implies key differences in the molecular mechanisms controlling the timing of flowering in rice versus *Arabidopsis*.

Genes corresponding to a number of flowering time QTLs have been identified in rice. These include *Heading date 3a (Hd3a)*, which has been identified as an orthologue of the *Arabidopsis FT* gene (Figure 1B) (Kojima et al., 2002). *Hd3a* is expressed in leaves and the Hd3a protein is transported to the shoot apex where it accelerates floral development (Tamaki et al., 2007). Thus, *Hd3a* mediates the main output of the daylength pathway in rice and fulfils a role similar to *FT* in *Arabidopsis* (Figure 1B) (Kojima et al., 2002; Kojima et al., 2008). Unlike *FT*, which is expressed in long-days, *Hd3a* is expressed in short days (Kojima et al., 2002; Tamaki et al., 2007). This is a critical difference between the seasonal flowering responses of *Arabidopsis* and rice (Figure 1B).

A second flowering time QTL, *Heading date 1 (Hd1)* (also known as *SE1*) has been identified as a *CO* homologue (Yokoo et al., 1980; Yano et al., 2000). *Hd1* is expressed with a diurnal rhythm which, like *CO* in *Arabidopsis*, peaks in the afternoon and presumably results in high HD1 activity late in the afternoon in long-days (Figure 1B). The rice orthologue of *GI* (*OsGI*) has a diurnal rhythm of gene expression, and constitutive over-expression of *OsGI* is associated with higher expression of *Hd1* (Hayama et al., 2002; Hayama et al., 2003). Thus, *OsGI* might regulate diurnal expression of *Hd1*, similar to the regulation of *CO* by *GI* in *Arabidopsis*. Unlike *CO*, which activates *FT*, high *Hd1* expression in long-days is not associated with increased expression of *Hd3a* (Hayama et al., 2003).

Why high *Hd1* expression is associated with low expression of *Hd3a* in long-days is unclear. One possibility is that Hd1 has an identical function to CO, but other factors modify the activity of the daylength flowering response pathway in rice. One putative candidate has been mapped to the *Ghd7* locus (Figure 1B) (Xue et al., 2008). *Ghd7* is predicted to encode a protein with a zinc finger and a CCT domain, which is expressed predominantly during the light period in long-days (Figure 1B). Deletions at the *Ghd7* locus are associated with fewer grains per plant, reduced plant height and earlier heading date. GHD7 represses *Hd3a*, and delays flowering in long-days (Xue et al., 2008). If *Ghd7* is deleted, expression of *Hd3a* is activated in long-days (Xue et al., 2008). This suggests that the daylength response pathway of rice retains the capacity to activate expression of *Hd3a* in long-days but this is normally suppressed by GHD7 (Figure 1B). A critical experiment will be to determine whether this

occurs through *Hdl* (i.e. does a null *hdl* mutation suppress early flowering of a line that lacks *Ghd7* in long-days).

Other factors that might modify the activity of both *Ghd7* and *Hdl* have also been identified. Plants that have mutations in a particular rice HAP factor, *Ghd8* (also known as *DTH8*) share many of the phenotypes of plants with deletions of *Ghd7* i.e. fewer grains per plant, reduced height, earlier heading and these phenotypes are only present when the plants are grown in long-days (Wei et al., 2010; Yan et al., 2010). The mechanisms underlying these phenotypes appear to be similar to that in *ghd7* nulls (Figure 1B) (Wei et al., 2010; Yan et al., 2010). Given that HAP factors interact with proteins that contain CCT domains it is likely that the activity of GHD7 and or HD1 is modified by HAP factors such as *Ghd8* (Wei et al., 2010; Yan et al., 2010). A critical experiment would be to determine if there are any interactions between *Ghd7* and *Ghd8* or *Hdl* (i.e. is the mutation to *Ghd8* additive in a *ghd7* or *hdl* null background).

Lines that lack a functional *Hdl* gene flower later in short days compared to wild type plants. This shows that *Hdl* does play a role in promoting flowering in short days (Yano et al., 2000; Kojima et al., 2002), but *Hdl* explains only a small proportion of the total acceleration of flowering in short days, suggesting that other factors are more important for the short day flowering response. Another QTL in rice has been localised to the *Early heading date 1* (*Ehd1*) gene, which encodes a B-Response Regulator, a type of protein involved in signal transduction in plants and other organisms (Hwang et al., 2002; Doi et al., 2004). In short days *Ehd1* promotes expression of *Hd3a* and a related *FT-like* gene, *Rice FT1* (*RFT1*) (Doi et al., 2004). *Ehd1* has recently been shown to be up-regulated by blue light and *OsGI* and repressed by *Ghd7* through a red light dependent mechanism (Itoh et al., 2010).

Expression of *Ehd1* is up-regulated by the MADS box gene *OsMADS51* (Kim et al., 2007); constitutive over-expression of *OsMADS51* is associated with increased expression of *Ehd1* and *Ehd1* expression is reduced when *OsMADS51* expression is reduced (Figure 1B) (Kim et al., 2007). *OsMADS51* also promotes expression of *Hd3a*, possibly through *Ehd1* (Figure 1B). *OsMADS51* may be regulated by *OsGI*; reduced expression of *OsGI* is associated with lower expression of *OsMADS51* (Kim et al., 2007). So *OsMADS51* might act as an intermediate between *OsGI* and *Ehd1*, to promote expression of *Ehd1* (Figure 1B). The *Oryza sativa* *INDETERMINATE1* gene (*OsId1*, *RId1* or *Early heading date 2*) is also required for expression of *Ehd1* and *Hd3a* (Matsubara et al., 2008; Park et al., 2008; Wu et al., 2008).

There are no homologues of *Ghd7*, *OsId1*, *Ehd1* or *OsMADS51* in *Arabidopsis*. Therefore, it seems that the different seasonal flowering responses of rice compared to *Arabidopsis* might result from the activity of genes not found in *Arabidopsis*.

The daylength response in temperate cereals; long-day grasses.

Generally temperate cereals, such as wheat and barley, flower more rapidly in long-days due to acceleration of the transition to reproductive growth and more rapid inflorescence development after this transition. As in rice and *Arabidopsis*, this daylength flowering response appears to involve the activation of a *FT-like* gene, *FT-like 1* (*FT1*), which is induced in the leaves in long-days (Turner et al., 2005) (Figure 1C). *CO-like* genes have also been identified in barley (*HvCO1* and *HvCO2*), wheat (*TaHd1* and *TaHd2*), maize (*conz1*) and *Lolium* (*LpCO3*) (Griffiths et al., 2003, Nemoto et al., 2003, Martin et al., 2004, Miller et al., 2008). *TaHd1* complements the rice *Hd1* mutant, and *LpCO3* complements the *co* mutation (Martin et al., 2004), suggesting that the function of *CO* is conserved between the grasses and *Arabidopsis*. Similarly, the roles of *GI-like* genes are probably conserved between wheat, barley, rice and *Arabidopsis* (Hayama et al., 2002; Hayama et al., 2003; Dunford et al., 2005; Zhao et al., 2005).

In temperate cereals natural variation in daylength sensitivity is controlled primarily by *PHOTOPERIOD1* (*PPD1*). *PPD1* encodes a protein with a CCT domain which belongs to the *PRR* family. *PPD1* shows a diurnal rhythm of gene expression (Figure 1C) (Turner et al., 2005). Some varieties of barley carry a non-functional version of *PPD1* (*ppd-h1*). These show reduced expression of *FT1* (*HvFT1*) and a weak acceleration of flowering in long-days (Turner et al., 2005). Conversely, some varieties of wheat carry versions of *PPD1* that have altered diurnal rhythm (Beales et al., 2007). These have increased expression of *FT1* and flower rapidly in short days, reducing the apparent impact of long-days on flowering time (Beales et al., 2007). Altered *PPD1* activity might influence daylength sensitivity by altering expression of *CO-like* genes (Turner et al., 2005). *PPD1* is related to the *PRR7* gene of *Arabidopsis*, which has a role in both light and temperature entrainment of the circadian clock, so *PPD1* might also influence thermo-sensitive flowering responses in cereals, in addition to regulating daylength responses.

Whereas in rice *Ehd1* promotes expression of *Hd3a* in short days no *Ehd1* orthologues have been identified in temperate cereals or related grasses such as *Brachypodium distachyon* (Higgins et al., 2010). This might explain why *FT1* is not expressed in short days in wheat and barley. Another key difference between rice and the temperate cereals is the

vernalization-response pathway which, as discussed below, down-regulates a *Ghd7-like* gene to promote expression of *FT1* in long-days.

The vernalization response of temperate cereals

Many varieties of wheat, barley, oats (*Avena sativa*) and rye (*Secale cereale*) require vernalization to flower. The vernalization response in these cereals appears to have evolved independently to the vernalization response of *Arabidopsis*. No *FLC-like* MADS box genes have been identified in temperate cereals. Instead, the delay of flowering prior to winter in vernalization-responsive wheat and barley varieties is mediated by the *VERNALIZATION2* (*VRN2*) gene (Takahashi and Yasada, 1971). *VRN2* encodes a protein with a zinc finger and a CCT domain, related to *Ghd7*, which is expressed in long-days with a diurnal pattern (Yan et al., 2004; Dubcovsky et al., 2006; Trevaskis et al., 2006). *VRN2* delays flowering in long-days by inhibiting expression of *FT1* (Figure 1C) (Hemming et al., 2008). Once plants have been vernalized, expression of *VRN2* decreases and plants are able to respond to long-days (Yan et al., 2004; Karsai et al., 2005; Dubcovsky et al., 2006; Trevaskis et al., 2006; Hemming et al., 2008; Sasani et al., 2009). *VRN2* has also been shown to regulate the expression of other *FT-like* genes that are thought to be important for flowering responses such as *FT3* (Casao et al., 2010).

Down-regulation of *VRN2* in vernalized plants is likely to be mediated by *VERNALIZATION1* (*VRN1*) (Figure 1C) (Trevaskis et al., 2006; Hemming et al., 2008). *VRN1* is a *APETALA1/FRUITFULL* (*API/FUL*)-like MADS box gene that is essential for flowering in temperate cereals (Yan et al., 2003; Danyluk et al., 2003; Trevaskis et al., 2003; Preston and Kellogg 2006; Shitsukawa et al., 2007). *VRN1* is initially expressed at low levels but is induced by vernalization (Figure 1C) (Yan et al., 2003; Danyluk et al., 2003; Trevaskis et al., 2003; von Zitzewitz et al., 2005). After vernalization, increased *VRN1* activity is associated with rapid inflorescence initiation (Hemming et al., 2008; Sasani et al., 2009). Expression of *VRN1* is associated with down-regulation of *VRN2* and up-regulation of *FT1* in long-days (Figure 1C) (Hemming et al., 2008). Thus, *VRN1* appears to act through two mechanisms to trigger flowering in vernalized plants; acceleration of the transition to reproductive growth at the shoot apex and activation of the long-day response in leaves through the activation of *FT* (Trevaskis et al., 2007).

In some varieties of wheat and barley *VRN1* is active without vernalization, so plants do not need to over-winter to flower (Yan et al., 2003; Danyluk et al., 2003; Trevaskis et al., 2003). This can be caused by mutations in the promoter of the *VRN1* gene, or by deletions

and insertions within the first intron (Yan et al., 2003; Fu et al., 2005; von Zitzewitz et al., 2005; Cockram et al., 2007; Szucs et al., 2007). The full length first intron of *VRN1* is not required for low-temperature induction of this gene (Trevaskis et al., 2007), suggesting that although the first intron is required for repression of *VRN1*, the low-temperature response is controlled by other regions of the gene.

In varieties that do require vernalization to flower, induction of *VRN1* by vernalization is associated with changes in histone methylation in the promoter and the intron regions of the *VRN1* gene (Oliver et al., 2009). So it appears that the memory of winter in temperate cereals is mediated by epigenetic changes that result in long term activation of the *VRN1* gene (Oliver et al., 2009). This mechanism is similar to what occurs at *FLC* in *Arabidopsis* but in cereals *VRN1* is repressed before winter and is activated by vernalization (Yan et al., 2003; Danyluk et al., 2003; Trevaskis et al., 2003; von Zitzewitz et al., 2005). Whereas in *Arabidopsis* *FLC* is expressed at high levels before winter and is repressed by vernalization (Michaels and Amasino, 1999; Sheldon et al., 1999). One mechanism which might explain why deletions and insertions in the first intron of *VRN1* result in higher expression could be the disruption of nucleosome positioning surrounding the *VRN1* gene. If the positioning of nucleosomes is somehow sequence specific or is dependent on other higher order structures then deletions or insertions could disrupt this positioning and result in a more 'open' structure that can be accessed more easily by transcriptional machinery (Bai et al., 2010; Segal et al., 2009).

Increased activity of *FTI* can also bypass the requirement for vernalization in cereals. This can occur through two mechanisms. In varieties where *VRN2* is deleted, long-days induce *FTI* and trigger flowering without vernalization (Yan et al., 2006; Hemming et al., 2008). Alternatively, mutations in the *FTI* gene itself can cause elevated expression of this gene (Yan et al., 2006). In wheat, an insertion in the promoter of the *FTI* gene causes increased *FTI* expression (identified genetically as dominant alleles of the *VRN3* locus) (Yan et al., 2006). This bypasses the delay of flowering by *VRN2* and allows plants to flower rapidly without vernalization. A similar association between dominant alleles of *VRN3* and elevated *FTI* expression occurs in barley (Yan et al., 2006), although the molecular basis for this increased expression of *FTI* is unclear (Hemming et al., 2008).

Genetic variation in *VRN1*, *VRN2*, *FTI* (*VRN3*) and *PPD1* has been used to breed temperate cereals suitable for different climates. For example, varieties that do not require vernalization can be sown in warm climates where vernalization is unlikely to occur, and can also be sown in spring and will flower without over-wintering.

The thermo-sensitive flowering response of temperate cereals.

Flowering time is regulated by ambient temperatures in temperate cereals. For example, einkorn wheat (*Triticum monococcum*) flowers more rapidly at 23°C than at 16°C, a similar temperature sensitive flowering response to that of *Arabidopsis*. However, it is not clear whether *SVP-like* genes delay flowering at low ambient temperatures in cereals as they do in *Arabidopsis*. Three *SVP-like* genes have been identified in barley: *Barley MADSI (BMI)*, *BMI0* and *Hordeum vulgare VEGETATIVE TO REPRODUCTIVE TRANSITION 2 (HvVRT2)* (Schmitz et al., 2000; Kane et al., 2005; Trevaskis et al., 2007). Expression of these genes increases rapidly at low-temperatures, suggesting a role for *SVP-like* genes in regulating temperature responses (Figure 1C) (Trevaskis et al., 2007). When constitutively over-expressed in barley, *BMI* and *BMI0* inhibit floral meristem identity and delay heading by slowing inflorescence development after the transition to reproductive growth (Trevaskis et al., 2007). *HvFT1* and the daylength response pathway regulate this stage of development, but it is not known whether *BMI* or *BMI0* represses *HvFT1*. A role in regulation of the vernalization response has been suggested for *HvVRT2* (Kane et al., 2005), but this now seems unlikely (Trevaskis et al., 2007; Pidal et al., 2010). While there is some evidence that *HvVRT2* might interact with the promoter of *HvVRN1* (Kane et al., 2007), it is probably not involved in regulating the vernalization response, as deletions in the promoter region of *VRN1* do not affect induction of *VRN1* or affect flowering behaviour in response to vernalization (Pidal et al., 2010).

An *Earliness per se* gene that reduces the influence of temperature on flowering time has been identified and mapped in einkorn wheat (Figure 1C) (Bullrich et al., 2002; Appendino and Slafer, 2003; Lewis et al., 2008). Cloning of this gene might offer further insight into how ambient temperatures influence flowering time in cereals.

How useful is *Arabidopsis* as a model for understanding the regulation of flowering time in cereals and other plants?

Arabidopsis will continue to provide insights into how flowering time is regulated in cereals. One area where *Arabidopsis* will likely have a large impact is in unravelling the interactions between CCT domains and HAP proteins; the availability of different mutants will be invaluable in determining the functions of the many members of these conserved gene families (Mantovani, 1999). In other areas, *Arabidopsis* is less useful as a model for the study of seasonal flowering responses in cereals, since it lacks many of the genes that regulate flowering in cereals, such as *VRN2* and *Ehd1*. Furthermore, *FLC-like* genes are not found in

cereals, so homologues of *Arabidopsis* genes that influence flowering time by regulating *FLC* might have different roles. For example, *VIN3-like* genes have been identified in wheat (Fu et al., 2007) but it is not clear whether these genes regulate flowering time in the absence of any *FLC-like* genes. This may also be true for other plant species that are more closely related to *Arabidopsis*. For instance, a recent study identified a pair of *FT-like* genes in beet (*Beta vulgaris ssp. vulgaris*) that appear to regulate flowering responses differently to both *Arabidopsis* and cereals (Pin et al., 2010). This finding suggests that the vernalization response has evolved separately in a number of different plant species and further highlights the difficulties of translating research from *Arabidopsis* into different crop species.

Conclusion

Plants respond to environmental cues such as daylength, vernalization and ambient temperature in order to flower under the most favourable conditions. *Arabidopsis* has been used extensively as a model plant to study the pathways involved in flowering, which are now relatively well understood in this plant. Recent efforts to extend the understanding of flowering-time pathways in cereals have highlighted key differences between the pathways of *Arabidopsis* and cereal crops, and shown that seasonal flowering responses are to a large extent controlled by different genes in cereals, which is particularly true for the vernalization response. This highlights the need to study flowering responses particularly the vernalization response directly in cereal crop species or in a model species that is more closely related to cereals such as *Brachypodium*.

Objectives / Outline of Thesis

The main objective of this thesis was to further investigate the molecular mechanisms of the vernalization response in temperate cereals.

Using barley as a model system, microarray analysis was performed to identify genes that are regulated by vernalization (**Chapter 2**). Following the identification of genes that are regulated by vernalization one candidate was characterised in detail; *HvODDSOC2*, a grass specific MADS box gene that is repressed by vernalization (**Chapter 3**). Finally, the regulation and function of barley *SOC1-like* genes was investigated to determine if the role of *SOC1-like* genes is conserved in *Arabidopsis* and barley (**Chapter 4**). **Chapter 5** includes a general discussion about the findings from this thesis and implications for future research.

Literature Cited

- Abe M, Kobayashi Y, Yamamoto S, Daimon Y, Yamaguchi A, Ikeda Y, Ichinoki H, Notaguchi M, Goto K, Araki T** (2005) FD, a bZIP protein mediating signals from the floral pathway integrator FT at the shoot apex. *Science* **309**: 1052-1056.
- An H, Roussot C, Suarez-Lopez P, Corbesier L, Vincent C, Pineiro M, Hepworth S, Mouradov A, Justin S, Turnbull C, Coupland G** (2004) CONSTANS acts in the phloem to regulate a systemic signal that induces photoperiodic flowering of *Arabidopsis*. *Development* **131**: 3615-3626.
- Appendino ML, Slafer GA** (2003) Earliness per se and its dependence upon temperature in diploid wheat lines differing in the major gene *Eps-A(m)1* alleles. *Journal of Agricultural Science* **141**: 149-154.
- Aukerman MJ, Sakai H** (2003) Regulation of Flowering Time and Floral Organ Identity by a MicroRNA and Its *APETALA2-Like* Target Genes. *Plant Cell* **15**: 2730-2741.
- Bai L, Morozov AV** (2010) Gene regulation by nucleosome positioning. *Trends in Genetics* **26**: 476-483.
- Balasubramanian S, Sureshkumar S, Lempe J, Weigel D** (2006) Potent induction of *Arabidopsis thaliana* flowering by elevated growth temperature. *PLoS Genetics* **2**: 980-989.
- Beales J, Turner A, Griffiths S, Snape J, Laurie D** (2007) A Pseudo-Response Regulator is misexpressed in the photoperiod insensitive *Ppd-D1a* mutant of wheat (*Triticum aestivum* L.). *Theoretical and Applied Genetics* **115**: 721-733.
- Blazquez MA, Ahn JH, Weigel D** (2003) A thermosensory pathway controlling flowering time in *Arabidopsis thaliana*. *Nature Genetics* **33**: 168-171.
- Bullrich, L., Appendino, M. L., Tranquilli, G., Lewis, S. Dubcovsky, J** (2002) Mapping of a thermo-sensitive earliness per se gene on *Triticum monococcum* chromosome 1Am. *Theoretical and Applied Genetics* **105**: 585-593.
- Cao R, Zhang Y** (2004) SUZ12 Is Required for Both the Histone Methyltransferase Activity and the Silencing Function of the EED-EZH2 Complex. *Molecular Cell* **15**: 57-67.
- Casao MC, Igartua E, Karsai I, Lasa JM, Gracia MP, Casas AM** (2010) Expression analysis of vernalization and day-length response genes in barley (*Hordeum vulgare* L.) indicates that *VRNH2* is a repressor of *PPDH2* (*HvFT3*) under long-days. *Journal of Experimental Botany*, In press.

- Childs KL, Miller FR, Cordonnier-Pratt MM, Pratt LH, Morgan PW, Mullet JE (1997)** The Sorghum Photoperiod Sensitivity Gene, *Ma3*, Encodes a Phytochrome B. *Plant Physiology* **113**: 611-619.
- Cockram J, Chiapparino E, Taylor S, Stamati K, Donini P, Laurie D, O'Sullivan D (2007)** Haplotype analysis of vernalization loci in European barley germplasm reveals novel *VRN-H1* alleles and a predominant winter *VRN-H1/VRN-H2* multi-locus haplotype. *Theoretical and Applied Genetics* **115**: 993-1001.
- Corbesier L, Vincent C, Jang S, Fornara F, Fan Q, Searle I, Giakountis A, Farrona S, Gissot L, Turnbull C, Coupland G (2007)** FT Protein Movement Contributes to Long-Distance Signaling in Floral Induction of Arabidopsis. *Science* **316**: 1030-1033.
- Danilevskaya ON, Meng X, Hou Z, Ananiev EV, Simmons CR (2008)** A Genomic and Expression Compendium of the Expanded PEBP Gene Family from Maize. *Plant Physiology* **46**: 250-264.
- Danyluk J, Kane NA, Breton G, Limin AE, Fowler DB, Sarhan F (2003)** *TaVRT-1*, a putative transcription factor associated with vegetative to reproductive transition in cereals. *Plant Physiology* **132**: 1849-1860.
- De Lucia F, Crevillen P, Jones AME, Greb T, Dean C (2008)** A PHD-Polycomb Repressive Complex 2 triggers the epigenetic silencing of *FLC* during vernalization. *Proceedings of the National Academy of Sciences of the United States of America* **105**: 16831-16836.
- Doi K, Izawa T, Fuse T, Yamanouchi U, Kubo T, Shimatani Z, Yano M, Yoshimura A (2004)** *Ehd1*, a B-type response regulator in rice, confers short-day promotion of flowering and controls *FT-like* gene expression independently of *Hdl*. *Genes and Development* **18**: 926-936.
- Dubcovsky J, Loukoianov A, Fu D, Valarik M, Sanchez A, Yan L (2006)** Effect of Photoperiod on the Regulation of Wheat Vernalization Genes *VRN1* and *VRN2*. *Plant Molecular Biology* **60**: 469-480.
- Dunford RP, Griffiths S, Christodoulou V, Laurie DA (2005)** Characterisation of a barley (*Hordeum vulgare* L.) homologue of the Arabidopsis flowering time regulator *GIGANTEA*. *Theoretical and Applied Genetics* **110**: 925-931.
- Faure S, Higgins J, Turner A, Laurie DA (2007)** The *FLOWERING LOCUS T-Like* Gene Family in Barley (*Hordeum vulgare*). *Genetics* **176**: 599-609.

- Finnegan EJ, Dennis ES** (2007) Vernalization-Induced Trimethylation of Histone H3 Lysine 27 at *FLC* Is Not Maintained in Mitotically Quiescent Cells. *Current Biology* **17**: 1978-1983.
- Fornara F, Gregis V, Pelucchi N, Colombo L, Kater M** (2008) The rice *StMADS11-like* genes *OsMADS22* and *OsMADS47* cause floral reversions in *Arabidopsis* without complementing the *svp* and *agl24* mutants. *Journal of Experimental Botany* **59**: 2181-2190.
- Fu D, Dunbar M, Dubcovsky J** (2007) Wheat *VIN3-like* PHD finger genes are up-regulated by vernalization. *Molecular Genetics and Genomics* **277**: 301-313.
- Fu DL, Szucs P, Yan LL, Helguera M, Skinner JS, von Zitzewitz J, Hayes PM, Dubcovsky J** (2005) Large deletions within the first intron in *VRN-1* are associated with spring growth habit in barley and wheat. *Molecular Genetics and Genomics* **273**: 54-65.
- Greb T, Mylne JS, Crevillen P, Geraldo N, An H, Gendall AR, Dean C** (2007) The PHD Finger Protein VRN5 Functions in the Epigenetic Silencing of *Arabidopsis FLC*. *Current Biology* **17**: 73-78.
- Griffiths S, Dunford RP, Coupland G, Laurie DA** (2003) The Evolution of *CONSTANS-Like* Gene Families in Barley, Rice, and *Arabidopsis*. *Plant Physiology* **131**: 1855-1867.
- Guo H, Yang H, Mockler TC, Lin C** (1998) Regulation of Flowering Time by *Arabidopsis* Photoreceptors. *Science* **279**: 1360-1363.
- Hayama R, Izawa T, Shimamoto K** (2002) Isolation of Rice Genes Possibly Involved in the Photoperiodic Control of Flowering by a Fluorescent Differential Display Method. *Plant and Cell Physiology* **43**: 494-504.
- Hayama R, Yokoi S, Tamaki S, Yano M, Shimamoto K** (2003) Adaptation of photoperiodic control pathways produces short-day flowering in rice. *Nature* **422**: 719-722.
- He Y, Michaels SD, Amasino RM** (2003) Regulation of Flowering Time by Histone Acetylation in *Arabidopsis*. *Science* **302**: 1751-1754.
- Helliwell CA, Wood CC, Robertson M, Peacock WJ, Dennis ES** (2006) The *Arabidopsis* FLC protein interacts directly in vivo with *SOCI* and *FT* chromatin and is part of a high-molecular-weight protein complex. *The Plant Journal* **46**: 183-192.

- Hemming MN, Peacock WJ, Dennis ES, Trevaskis B** (2008) Low-temperature and daylength cues are integrated to regulate *FLOWERING LOCUS T* in barley. *Plant Physiology* **147**: 355-366.
- Hepworth SR, Valverde F, Ravenscroft D, Mouradov A, Coupland G** (2002) Antagonistic regulation of flowering-time gene *SOCI* by *CONSTANS* and *FLC* via separate promoter motifs. *EMBO Journal* **21**: 4327-4337.
- Higgins JA, Bailey PC, Laurie DA** (2010) Comparative Genomics of Flowering Time Pathways Using *Brachypodium distachyon* as a Model for the Temperate Grasses. *PLoS ONE* **5**: e10065.
- Hwang I, Chen H-C, Sheen J** (2002) Two-Component Signal Transduction Pathways in Arabidopsis. *Plant Physiology* **129**: 500-515.
- Imaizumi T, Kay SA** (2006) Photoperiodic control of flowering: not only by coincidence. *Trends in Plant Science* **11**: 550-558.
- Imaizumi T, Schultz TF, Harmon FG, Ho LA, Kay SA** (2005) FKF1 F-Box Protein Mediates Cyclic Degradation of a Repressor of *CONSTANS* in Arabidopsis. *Science* **309**: 293-297.
- Itoh H, Nonoue Y, Yano M, Izawa T** (2010) A pair of floral regulators sets critical day length for *Hd3a* florigen expression in rice. *Nature Genetics* **42**: 635-638.
- Izawa T, Oikawa T, Tokutomi S, Okuno K, Shimamoto K** (2000) Phytochromes confer the photoperiodic control of flowering in rice (a short-day plant). *The Plant Journal* **22**: 391-399.
- Jaeger KE, Graf A, Wigge PA** (2006) The control of flowering in time and space. *Journal of Experimental Botany* **57**: 3415-3418.
- Jang S, Marchal V, Panigrahi KCS, Wenkel S, Soppe W, Deng XW, Valverde F, Coupland G** (2008) Arabidopsis *COPI* shapes the temporal pattern of *CO* accumulation conferring a photoperiodic flowering response. *EMBO Journal* **27**: 1277-1288.
- Johanson U, West J, Lister C, Michaels S, Amasino R, Dean C** (2000) Molecular Analysis of *FRIGIDA*, a Major Determinant of Natural Variation in Arabidopsis Flowering Time. *Science* **290**: 344-347.
- Jung J-H, Seo Y-H, Seo PJ, Reyes JL, Yun J, Chua N-H, Park C-M** (2007) The *GIGANTEA*-Regulated *MicroRNA172* Mediates Photoperiodic Flowering Independent of *CONSTANS* in Arabidopsis. *Plant Cell* **19**: 2736-2748.

- Kane NA, Danyluk J, Tardif G, Ouellet F, Laliberte JF, Limin AE, Fowler DB, Sarhan F (2005)** *TaVRT-2*, a member of the *StMADS-11* clade of flowering repressors, is regulated by vernalization and photoperiod in wheat. *Plant Physiology* **138**: 2354-2363.
- Kane NA, Agharbaoui Z, Diallo AO, Adam H, Tominaga Y, Ouellet F, Sarhan F (2007)** *TaVRT2* represses transcription of the wheat vernalization gene *TaVRN1*. *The Plant Journal*, **51**: 670-680.
- Kardailsky I, Shukla VK, Ahn JH, Dagenais N, Christensen SK, Nguyen JT, Chory J, Harrison MJ, Weigel D (1999)** Activation Tagging of the Floral Inducer *FT*. *Science* **286**: 1962-1965.
- Karsai I, Szucs P, Meszaros K, Filichkina T, Hayes PM, Skinner JS, Lang L, Bedo Z (2005)** The *Vrn-H2* locus is a major determinant of flowering time in a facultative × winter growth habit barley (*Hordeum vulgare* L.) mapping population. *Theoretical and Applied Genetics* **110**: 1458-1466.
- Kim SL, Lee SY, Kim HJ, Nam HG, An GH (2007)** *OsMADS51* is a short-day flowering promoter that functions upstream of *Ehd1*, *OsMADS14*, and *Hd3a*. *Plant Physiology* **145**: 1484-1494.
- King RW, Moritz T, Evans LT, Martin J, Andersen CH, Blundell C, Kardailsky I, Chandler PM (2006)** Regulation of Flowering in the Long-day Grass *Lolium temulentum* by Gibberellins and the *FLOWERING LOCUS T* Gene. *Plant Physiology* **141**: 498-507.
- Kobayashi Y, Kaya H, Goto K, Iwabuchi M, Araki T (1999)** A Pair of Related Genes with Antagonistic Roles in Mediating Flowering Signals. *Science* **286**: 1960-1962.
- Kojima S, Takahashi Y, Kobayashi Y, Monna L, Sasaki T, Araki T, Yano M (2002)** *Hd3a*, a rice orthologue of the Arabidopsis *FT* gene, promotes transition to flowering downstream of *Hdl* under short-day conditions. *Plant and Cell Physiology* **43**: 1096-1105.
- Komiya R, Ikegami A, Tamaki S, Yokoi S, Shimamoto K (2008)** *Hd3a* and *RFT1* are essential for flowering in rice. *Development* **135**: 767-774.
- Koornneef M, Blankestijndevries H, Hanhart C, Soppe W, Peeters T (1994)** The phenotype of some late-flowering mutants is enhanced by a locus on chromosome-5 that is not effective in the *Landsberg erecta* wild-type. *The Plant Journal* **6**: 911-919.

- Koornneef M, Hanhart CJ, Veen JH** (1991) A genetic and physiological analysis of late flowering mutants in *Arabidopsis thaliana*. *Molecular Genetics and Genomics* **229**: 57-66.
- Kumimoto RW, Zhang Y, Siefers N, Holt BF** (2010) *NF-YC3*, *NF-YC4* and *NF-YC9* are required for CONSTANS-mediated, photoperiod-dependent flowering in *Arabidopsis thaliana*. *The Plant Journal* **63**: 379-391.
- Lee I, Michaels SD, Masshardt AS, Amasino RM** (1994) The late-flowering phenotype of *FRIGIDA* and mutations in *LUMINIDEPENDENS* is suppressed in the *Landsberg erecta* strain of *Arabidopsis*. *The Plant Journal* **6**: 903-909.
- Lee S, Choi SC, An G** (2008) Rice SVP-group MADS-box proteins, *OsMADS22* and *OsMADS55*, are negative regulators of brassinosteroid responses. *The Plant Journal* **54**: 93-105.
- Lee JH, Cho YS, Yoon HS, Suh M, Moon J, Lee I, Weigel D, Yun CH, Kim JK** (2005) Conservation and Divergence of *FCA* Function between *Arabidopsis* and Rice. *Plant Molecular Biology* **58**: 823-838.
- Lee JH, Yoo SJ, Park SH, Hwang I, Lee JS, Ahn JH** (2007) Role of *SVP* in the control of flowering time by ambient temperature in *Arabidopsis*. *Genes and Development* **21**: 397-402.
- Lee H, Yoo SJ, Lee JH, Kim W, Yoo SK, Fitzgerald H, Carrington JC, Ahn JH** (2010) Genetic framework for flowering-time regulation by ambient temperature-responsive miRNAs in *Arabidopsis*. *Nucleic Acids Research* **38**: 3081-3093.
- Lee SY, Kim J, Han JJ, Han MJ, An GH** (2004) Functional analyses of the flowering time gene *OsMADS50*, the putative *SUPPRESSOR OF OVEREXPRESSION OF CONSTANS 1/AGAMOUS-LIKE 20 (SOC1/AGL20)* orthologue in rice. *The Plant Journal* **38**: 754-764.
- Lewis S, Faricelli ME, Appendino ML, Valarik M, Dubcovsky J** (2008) The chromosome region including the earliness per se locus *Eps-Am1* affects the duration of early developmental phases and spikelet number in diploid wheat. *Journal of Experimental Botany* **59**: 3595-3607.
- Li CX, Dubcovsky J** (2008) Wheat FT protein regulates *VRN1* transcription through interactions with FDL2. *The Plant Journal* **55**: 543-554.
- Li D, Liu C, Shen L, Wu Y, Chen H, Robertson M, Helliwell CA, Ito T, Meyerowitz E, Yu H** (2008) A repressor complex governs the integration of flowering signals in *Arabidopsis*. *Developmental Cell* **15**: 110-120.

- Lu Q, Xu ZK, Song RT** (2006) *OsFY*, a homolog of *AtFY*, encodes a protein that can interact with OsFCA-gamma in rice (*Oryza sativa L.*). *Acta Biochimica Et Biophysica Sinica* **38**: 492-499.
- Mantovani R** (1999) The molecular biology of the CCAAT-binding factor NF-Y. *Gene* **239**: 15-27.
- Marquardt S, Boss PK, Hadfield J, Dean C** (2006) Additional targets of the Arabidopsis autonomous pathway members, *FCA* and *FY*. *Journal of Experimental Botany* **57**: 3379-3386.
- Martin J, Storgaard M, Andersen CH, Nielsen KK** (2004) Photoperiodic regulation of flowering in perennial ryegrass involving a *CONSTANS-like* homolog. *Plant Molecular Biology* **56**: 159-169.
- Matsubara K, Yamanouchi U, Wang Z-X, Minobe Y, Izawa T, Yano M** (2008) *Ehd2*, a rice ortholog of the maize *IDI* gene, promotes flowering by upregulating *Ehd1*. *Plant Physiology* **148**: 1425-1435.
- Mathieu J, Yant LJ, Murdter F, Kuttner F, Schmid M** (2009) Repression of Flowering by the miR172 Target *SMZ*. *PLoS Biology* **7**: e1000148.
- McNabb DS, Xing YY, Guarente L** (1995) Cloning of Yeast *HAP5* – A novel subunit of a heterotrimeric complex required for CCAAT binding. *Genes and Development* **9**: 47-58.
- Michaels SD, Amasino RM** (1999) *FLOWERING LOCUS C* Encodes a Novel MADS Domain Protein That Acts as a Repressor of Flowering. *Plant Cell* **11**: 949-956.
- Michaels SD, Himelblau E, Kim SY, Schomburg FM, Amasino RM** (2005) Integration of Flowering Signals in Winter-Annual Arabidopsis. *Plant Physiology* **137**: 149-156.
- Miller T, Muslin E, Dorweiler J** (2008) A maize *CONSTANS-like* gene, *conz1*, exhibits distinct diurnal expression patterns in varied photoperiods. *Planta* **227**: 1377-1388.
- Nemoto Y, Kisaka M, Fuse T, Yano M, Ogihara Y** (2003) Characterization and functional analysis of three wheat genes with homology to the *CONSTANS* flowering time gene in transgenic rice. *The Plant Journal* **36**: 82-93.
- Onouchi H, Igono MI, Perilleux C, Graves K, Coupland G** (2000) Mutagenesis of Plants Overexpressing *CONSTANS* Demonstrates Novel Interactions among Arabidopsis Flowering-Time Genes. *Plant Cell* **12**: 885-900.
- Opanowicz M, Vain P, Draper J, Parker D, Doonan JH.** 2008. *Brachypodium distachyon*: making hay with a wild grass. *Trends in Plant Science* **13**: 172-177.

- Oliver SN, Finnegan EJ, Dennis ES, Peacock WJ, Trevaskis B (2009)** Vernalization-induced flowering in cereals is associated with changes in histone methylation at the *VERNALIZATION1* gene. Proceedings of the National Academy of Sciences of the United States of America **106**: 8386-8391.
- Park SJ, Kim SL, Lee S, Je BI, Piao HL, Park SH, Kim CM, Ryu C-H, Park SH, Xuan Y-h, Colasanti J, An G, Han C-d (2008)** *Rice Indeterminate 1 (OsId1)* is necessary for the expression of *Ehd1 (Early heading date 1)* regardless of photoperiod. The Plant Journal **56**: 1018-1029.
- Pidal Br, Yan L, Fu D, Zhang F, Tranquilli G, Dubcovsky J (2009)** The CArG-Box Located Upstream from the Transcriptional Start of Wheat Vernalization Gene *VRN1* Is Not Necessary for the Vernalization Response. Journal of Heredity **100**: 355-364.
- Pin PA, Benlloch R, Bonnet D, Wremerth-Weich E, Kraft T, Gielen JLL, Nilsson O (2010)** An Antagonistic Pair of *FT* Homologs Mediates the Control of Flowering Time in Sugar Beet. Science **330**: 1397-1400.
- Preston JC, Kellogg EA (2008)** Discrete Developmental Roles for Temperate Cereal Grass *VERNALIZATION1/FRUITFULL-Like* Genes in Flowering Competency and the Transition to Flowering. Plant Physiology **146**: 265-276.
- Putterill J, Robson F, Lee K, Simon R, Coupland G (1995)** The *CONSTANS* gene of Arabidopsis promotes flowering and encodes a protein showing similarities to zinc finger transcription factors. Cell **80**: 847-857.
- Robson F, Costa MMR, Hepworth SR, Vizir I, Pineiro M, Reeves PH, Putterill J, Coupland G (2001)** Functional importance of conserved domains in the flowering-time gene *CONSTANS* demonstrated by analysis of mutant alleles and transgenic plants. The Plant Journal **28**: 619-631.
- Ryu C, Lee S, Cho L, Kim S, Lee Y, Choi S, Jeong H, Yi J, Park S, Han C, An G (2009)** *OsMADS50* and *OsMADS56* function antagonistically in regulating long-day (LD)-dependent flowering in rice. Plant, Cell and Environment **32**: 1412-1427.
- Salome PA, McClung CR (2005)** *PSEUDO-RESPONSE REGULATOR 7* and *9* are partially redundant genes essential for the temperature responsiveness of the Arabidopsis circadian clock. Plant Cell **17**: 791-803.
- Sanda SL, Amasino RM (1996)** Ecotype-Specific Expression of a Flowering Mutant Phenotype in Arabidopsis thaliana. Plant Physiology **111**: 641-644.
- Sasani S, Hemming MN, Oliver SN, Greenup A, Tavakkol-Afshari R, Mahfoozi S, Poustini K, Sharifi H-R, Dennis ES, Peacock WJ, Trevaskis B (2009)** The

- influence of vernalization and daylength on expression of flowering-time genes in the shoot apex and leaves of barley (*Hordeum vulgare*). *Journal of Experimental Botany* **60**: 2169-2178.
- Sawa M, Nusinow DA, Kay SA, Imaizumi T** (2007) *FKF1* and *GIGANTEA* Complex Formation Is Required for Day-Length Measurement in Arabidopsis. *Science* **318**: 261-265.
- Schmitz J, Franzen R, Ngyuen TH, Garcia-Maroto F, Pozzi C, Salamini F, Rohde W** (2000) Cloning, mapping and expression analysis of barley MADS-box genes. *Plant Molecular Biology* **42**: 899-913.
- Schubert D, Primavesi L, Bishopp A, Roberts G, Doonan J, Jenuwein T, Goodrich J** (2006) Silencing by plant Polycomb-group genes requires dispersed trimethylation of histone H3 at lysine 27. *EMBO Journal* **25**: 4638-4649.
- Sheldon CC, Burn JE, Perez PP, Metzger J, Edwards JA, Peacock WJ, Dennis ES** (1999) The *FLF* MADS Box Gene: A Repressor of Flowering in Arabidopsis Regulated by Vernalization and Methylation. *Plant Cell* **11**: 445-458.
- Sheldon CC, Rouse DT, Finnegan EJ, Peacock WJ, Dennis ES** (2000) The molecular basis of vernalization: The central role of *FLOWERING LOCUS C (FLC)*. *Proceedings of the National Academy of Sciences of the United States of America* **97**: 3753-3758.
- Shitsukawa N, Ikari C, Shimada S, Kitagawa S, SakaMoto K, Saito H, Ryuto H, Fukunishi N, Abe T, Takumi S, Nasuda S, Murai K** (2007) The einkorn wheat (*Triticum monococcum*) mutant, *maintained vegetative phase*, is caused by a deletion in the *VRNI* gene. *Genes and Genetic Systems* **82**: 167-170.
- Segal E, Widom J** (2009) What controls nucleosome positions? *Trends in Genetics* **25**: 335-343.
- Sentoku N, Kato H, Kitano H, Imai R** (2005) *OsMADS22*, an *STMADS11-like* MADS-box gene of rice, is expressed in non-vegetative tissues and its ectopic expression induces spikelet meristem indeterminacy. *Molecular Genetics and Genomics* **273**: 1-9.
- Siefers N, Dang KK, Kumimoto RW, Bynum WE, Tayrose G, Holt BF** (2009) Tissue-Specific Expression Patterns of Arabidopsis *NF-Y* Transcription Factors Suggest Potential for Extensive Combinatorial Complexity. *Plant Physiology* **149**: 625-641.
- Simpson GG** (2004) The autonomous pathway: epigenetic and post-transcriptional gene regulation in the control of Arabidopsis flowering time. *Current Opinion in Plant Biology* **7**: 570-574.

- Suarez-Lopez P, Wheatley K, Robson F, Onouchi H, Valverde F, Coupland G (2001)** CONSTANS mediates between the circadian clock and the control of flowering in *Arabidopsis*. *Nature* **410**: 1116-1120.
- Sung S, Amasino RM (2004)** Vernalization in *Arabidopsis thaliana* is mediated by the PHD finger protein VIN3. *Nature* **427**: 159-164.
- Sung SB, Schmitz RJ, Amasino RM (2006)** A PHD finger protein involved in both the vernalization and photoperiod pathways in *Arabidopsis*. *Genes and Development* **20**: 3244-3248.
- Szucs P, Skinner JS, Karsai I, Cuesta-Marcos A, Haggard KG, Corey AE, Chen TH, Hayes PM (2007)** Validation of the *VRN-H2/VRN-H1* epistatic model in barley reveals that intron length variation in *VRN-H1* may account for a continuum of vernalization sensitivity. *Molecular Genetics and Genomics* **277**: 249-261.
- Takahashi R, Yasuda S (1971)** Genetics of earliness and growth habit in barley. In: Nilan RA ed. *Barley Genetics II (Proceedings of the Second International Barley Genetics Symposium)*. Washington State University Press.
- Tamaki S, Matsuo S, Wong HL, Yokoi S, Shimamoto K (2007)** *Hd3a* Protein Is a Mobile Flowering Signal in Rice. *Science* **316**: 1033-1036.
- Tiwari SB, Shen Y, Chang H-C, Hou Y, Harris A, Ma SF, McPartland M, Hymus GJ, Adam L, Marion C, Belachew A, Repetti PP, Reuber TL, Ratcliffe OJ (2010)** The flowering time regulator CONSTANS is recruited to the *FLOWERING LOCUS T* promoter via a unique cis-element. *New Phytologist* **187**: 57-66.
- Trevaskis B, Bagnall DJ, Ellis MH, Peacock WJ, Dennis ES (2003)** MADS box genes control vernalization-induced flowering in cereals. *Proceedings of the National Academy of Sciences of the United States of America* **100**: 13099-13104.
- Trevaskis B, Hemming MN, Peacock WJ, Dennis ES (2006)** *HvVRN2* Responds to Daylength, whereas *HvVRN1* Is Regulated by Vernalization and Developmental Status. *Plant Physiology* **140**: 1397-1405.
- Trevaskis B, Hemming MN, Dennis ES, Peacock WJ (2007)** The molecular basis of vernalization-induced flowering in cereals. *Trends in Plant Science* **12**: 352-357.
- Trevaskis B, Tadege M, Hemming MN, Peacock WJ, Dennis ES, Sheldon C (2007)** *Short Vegetative Phase-like* MADS-box genes inhibit floral meristem identity in barley. *Plant Physiology* **143**: 225-235.
- Turck F, Fornara F, Coupland G (2008)** Regulation and Identity of Florigen: *FLOWERING LOCUS T* Moves Center Stage. *Annual Review of Plant Biology* **59**: 573-594.

- Turner A, Beales J, Faure S, Dunford RP, Laurie DA** (2005) The Pseudo-Response Regulator *Ppd-H1* Provides Adaptation to Photoperiod in Barley. *Science* **310**: 1031-1034.
- Valverde F, Mouradov A, Soppe W, Ravenscroft D, Samach A, Coupland G** (2004) Photoreceptor Regulation of CONSTANS Protein in Photoperiodic Flowering. *Science* **303**: 1003-1006.
- von Zitzewitz J, Szucs P, Dubcovsky J, Yan LL, Francia E, Pecchioni N, Casas A, Chen THH, Hayes PM, Skinner JS** (2005) Molecular and structural characterization of barley vernalization genes. *Plant Molecular Biology* **59**: 449-467.
- Wei X, Xu J, Guo H, Jiang L, Chen S, Yu C, Zhou Z, Hu P, Zhai H, Wan J** (2010) *DTH8* Suppresses Flowering in Rice, Influencing Plant Height and Yield Potential Simultaneously. *Plant Physiology*. **153**: 1747-1758.
- Wenkel S, Turck F, Singer K, Gissot L, Le Gourrierec J, Samach A, Coupland G** (2006) CONSTANS and the CCAAT Box Binding Complex Share a Functionally Important Domain and Interact to Regulate Flowering of Arabidopsis. *Plant Cell* **18**: 2971-2984.
- Wigge PA, Kim MC, Jaeger KE, Busch W, Schmid M, Lohmann JU, Weigel D** (2005) Integration of Spatial and Temporal Information During Floral Induction in Arabidopsis. *Science* **309**: 1056-1059.
- Wood CC, Robertson M, Tanner G, Peacock WJ, Dennis ES, Helliwell CA** (2006) The Arabidopsis thaliana vernalization response requires a polycomb-like protein complex that also includes VERNALIZATION INSENSITIVE 3. *Proceedings of the National Academy of Sciences of the United States of America* **103**: 14631-14636.
- Wu CY, You CJ, Li CS, Long T, Chen GX, Byrne ME, Zhang QF** (2008) *RIDI*, encoding a Cys2/His2-type zinc finger transcription factor, acts as a master switch from vegetative to floral development in rice. *Proceedings of the National Academy of Sciences of the United States of America* **105**: 12915-12920.
- Xue W, Xing Y, Weng X, Zhao Y, Tang W, Wang L, Zhou H, Yu S, Xu C, Li X, Zhang Q** (2008) Natural variation in *Ghd7* is an important regulator of heading date and yield potential in rice. *Nature Genetics* **40**: 761-767.
- Yano M, Katayose Y, Ashikari M, Yamanouchi U, Monna L, Fuse T, Baba T, Yamamoto K, Umehara Y, Nagamura Y, Sasaki T** (2000) *Hdl1*, a Major Photoperiod Sensitivity Quantitative Trait Locus in Rice, Is Closely Related to the Arabidopsis Flowering Time Gene *CONSTANS*. *Plant Cell* **12**: 2473-2484.

- Yan L, Fu D, Li C, Blechl A, Tranquilli G, Bonafede M, Sanchez A, Valarik M, Yasuda S, Dubcovsky J** (2006) The wheat and barley vernalization gene *VRN3* is an orthologue of *FT*. Proceedings of the National Academy of Sciences of the United States of America **103**: 19581-19586.
- Yan L, Loukoianov A, Blechl A, Tranquilli G, Ramakrishna W, SanMiguel P, Bennetzen JL, Echenique V, Dubcovsky J** (2004) The Wheat *VRN2* Gene Is a Flowering Repressor Down-Regulated by Vernalization. Science **303**: 1640-1644.
- Yan L, Loukoianov A, Tranquilli G, Helguera M, Fahima T, Dubcovsky J** (2003) Positional cloning of the wheat vernalization gene *VRN1*. Proceedings of the National Academy of Sciences of the United States of America **100**: 6263-6268.
- Yan W-H, Wang P, Chen H-X, Zhou H-J, Li Q-P, Wang C-R, Ding Z-H, Zhang Y-S, Yu S-B, Xing Y-Z, Zhang Q-F** (2010) A Major QTL, *Ghd8*, Plays Pleiotropic Roles in Regulating Grain Productivity, Plant Height, and Heading Date in Rice. Molecular Plant, In press.
- Yanovsky MJ, Kay SA** (2002) Molecular basis of seasonal time measurement in Arabidopsis. Nature **419**: 308-312.
- Yokoo, M., Kikuchi, F., Nakane, A., and Fujimaki, H** (1980). Genetical analysis of heading time by aid of close linkage with blast, *Pyricularia oryzae*, resistance in rice. Bulletin of the National Institute of Agricultural Sciences Series D **31**:95-126.
- Zeevaart JAD** (2006) Florigen Coming of Age after 70 Years. Plant Cell **18**: 1783-1789.
- Zhao XY, Liu MS, Li JR, Guan CM, Zhang XS** (2005) The wheat *TaG11*, involved in photoperiodic flowering, encodes an Arabidopsis *GI* ortholog. Plant Molecular Biology **58**: 53-64.

Chapter 2

Transcriptome analysis of the vernalization response in barley (*Hordeum vulgare*) seedlings.

Based on the manuscript accepted for publication in PLoS ONE, February 2011.

Abstract

Temperate cereals, such as wheat (*Triticum spp.*) and barley (*Hordeum vulgare*), respond to the cold of winter by becoming more tolerant of freezing (cold acclimation) and by becoming competent to flower (vernalization). These responses occur concomitantly, but vernalization occurs over a longer time span and continues to influence development during spring. Previous studies identified *VERNALIZATION1 (VRN1)* as a master regulator of the vernalization response in cereals, but the extent to which other genes contribute is unclear. In this study the Barley1 Affymetrix chip was used to assay gene expression in barley seedlings during short or prolonged cold treatment. Gene expression was also assayed in the leaves of plants after prolonged cold treatment, in order to identify genes that show lasting changes to prolonged cold, which might contribute to vernalization-induced flowering. Many genes showed altered expression in response to short or long term cold treatments but these responses differed markedly. A limited number of genes showed lasting responses to prolonged cold treatment. These include genes known to be regulated by vernalization, such as *VRN1* and *ODDSOC2 (OS2)*, and also contigs encoding a calcium binding protein, 23-KD jasmonate induced proteins, an RNase S-like protein, a PR17d secretory protein and a serine acetyltransferase. Some contigs that were up-regulated by short term cold also showed lasting changes in expression levels after prolonged cold treatment. These include *COLD REGULATED 14B (COR14B)* and the barley homologue of *WHEAT COLD SPECIFIC 19 (WSC19)*, which were expressed at elevated levels after prolonged cold. Conversely, two *C-REPEAT BINDING FACTOR (CBF)* genes showed reduced expression after prolonged cold. Overall, these data show that a limited number of barley genes exhibit lasting changes in expression after prolonged cold treatment, highlighting the central role of *VRN1* in the vernalization response in cereals.

Introduction

In temperate regions, wheat (*Triticum spp.*) and barley (*Hordeum vulgare*) can be sown in autumn to grow vegetatively through winter before flowering in spring. Autumn sowing can enhance yield relative to later sowing times, but can also expose plants to freezing winter conditions (Entz and Fowler, 1991). Consequently, the capacity to survive winter frosts is an important trait for autumn-sown wheat and barley varieties grown in regions that experience cold winters (Koemel et al., 2004; Limin and Fowler, 2006; King and Heide, 2009).

Tolerance to winter frosts is established through cold acclimation, the process where freezing tolerance increases as temperatures decrease during autumn (Thomashow, 1999). Molecular analyses have identified low-temperature responsive genes that are induced during cold acclimation, such as ice crystallisation inhibitors and dehydrins, which protect against freezing damage (Thomashow, 1999). *C-REPEAT BINDING FACTOR (CBF)* genes encode transcription factors that play a critical role in the cold acclimation process (Thomashow, 1999). *CBF* genes are rapidly induced by low temperatures to activate genes that contribute to increased freezing tolerance (Thomashow, 1999). A cluster of *CBF* genes is linked to the *FROST TOLERANCE 2 (FR2)* locus on chromosome 5 of wheat and barley (5H), a locus associated with variation in frost tolerance (Roberts, 1990; Hayes et al., 1993; Fowler et al., 1996; Galiba et al., 2009). An increased number of *CBF* genes at the *FR2* locus might enhance cold acclimation in frost tolerant varieties (Stockinger et al., 2007; Knox et al., 2008).

A second mechanism contributing to frost tolerance in autumn-sown wheats and barleys is the vernalization requirement; the requirement for prolonged exposure to cold to make plants competent to flower. The requirement for vernalization delays the transition to reproductive growth until winter has passed, minimising the risk of frost damage to cold sensitive reproductive organs (Limin and Fowler, 2002). Furthermore, because cold acclimation pathways are less active after the transition to reproductive growth, the requirement for vernalization contributes to increased frost tolerance by lengthening the vegetative growth phase and allowing more time for cold acclimation to occur (Limin and Fowler, 2002). Thus, varieties sown in autumn in cold regions typically have a strong requirement for vernalization. In comparison, varieties that flower without vernalization typically have a reduced capacity for cold acclimation and are less frost tolerant (Koemel et al., 2004; Limin and Fowler, 2006).

During winter, low temperatures satisfy the vernalization requirement and trigger a quantitative flowering response, whereby longer exposure to cold causes more rapid flowering until the vernalization response is saturated after several weeks at low-temperatures (Gott et al., 1955). In cereals, vernalization-induced flowering is mediated by the activation of *VERNALIZATION1 (VRN1)*, a gene that promotes flowering (reviewed by Trevaskis, 2010). *VRN1* transcript levels show a quantitative response to cold, with longer durations of cold activating *VRN1* expression to greater extents, and expression of *VRN1* is maintained when vernalized plants are shifted to normal growth temperatures (Danyluk et al., 2003; Trevaskis et al., 2003; Yan et al., 2003; Sasani et al., 2009). This long term activation of *VRN1* might be mediated through vernalization-induced changes in the state of chromatin at the *VRN1* locus (Oliver et al., 2009).

Following vernalization, *VRN1* accelerates flowering by promoting the transition to reproductive development at the shoot apex and by making the leaves of vernalized plants competent to respond to increasing daylength during spring, which accelerates inflorescence development and stem elongation (Hemming et al., 2008). Many varieties of wheat and barley carry alleles of *VRN1* that are expressed without prior cold treatment (Takahashi and Yasuda, 1971; Danyluk et al., 2003; Trevaskis et al., 2003; Yan et al., 2003). These varieties flower without vernalization and can be grown in warm climates, where winter temperatures are not cold enough for vernalization, or sown in spring. By accelerating the transition to reproductive growth, active alleles of *VRN1* limit the time during which cold acclimation is possible and so reduce frost tolerance. Hence, *VRN1* has been identified as locus controlling frost tolerance (*FRI*) (Hayes et al., 1993; Limin and Fowler, 2002; Stockinger et al., 2007).

Cold acclimation and vernalization occur concomitantly when autumn-sown plants experience low-temperatures during winter, but vernalization occurs over longer periods and unlike cold acclimation, continues to influence development when plants return to warm temperatures. In this study we use microarrays to compare and contrast gene expression in barley seedlings exposed to short or prolonged cold treatments. Additionally, we compare gene expression in the leaves of vernalized versus non-vernalized plants. By comparing the effects of short and prolonged cold on the transcriptome we identify genes that show distinct low temperature responses. We were also able to identify genes that show lasting responses to prolonged cold

treatment, an expression pattern that defines vernalization-responsive genes. Possible roles for these genes in the vernalization response of cereals are discussed.

Results

The effects of short and prolonged cold on the transcriptome of barley seedlings were compared using the Affymetrix 22K Barley1 chip (see materials and methods, Fig. 1A) (Close et al., 2004). Expression levels were then verified for a subset of contigs using quantitative RT-PCR (Fig. S1). Pair wise comparisons of the different treatments were used to identify contigs that have altered expression in the short term, prolonged or post-cold treatments (Tables S1-6). Large numbers of contigs show altered expression ($p < 0.01$, > 2 fold change) in short (613 contigs) or prolonged (786 contigs) cold treatment (Fig. 2). In comparison only a limited number of contigs showed a lasting response to prolonged cold; i.e. significantly changed in both the prolonged cold and 1 day after prolonged cold samples (16 up and 44 down, Fig. 2).

Principal component analysis (PCA) (Wit and McClure, 2004) was used to visualise the level of similarity between gene expression profiles across the different treatments (Fig. 3). The first two principal components show that the short term and prolonged cold treatments were dissimilar to each other and to the control treatment (Fig. 3). In comparison the post cold treatment was more similar to the control treatment than to either the short or prolonged cold treatments. This indicates that cold has a strong influence on the transcriptome of barley but only a limited number of contiguous sequences or contigs show a lasting response to prolonged cold. All biological replicates showed a high degree of similarity for all four treatments (Fig. 3).

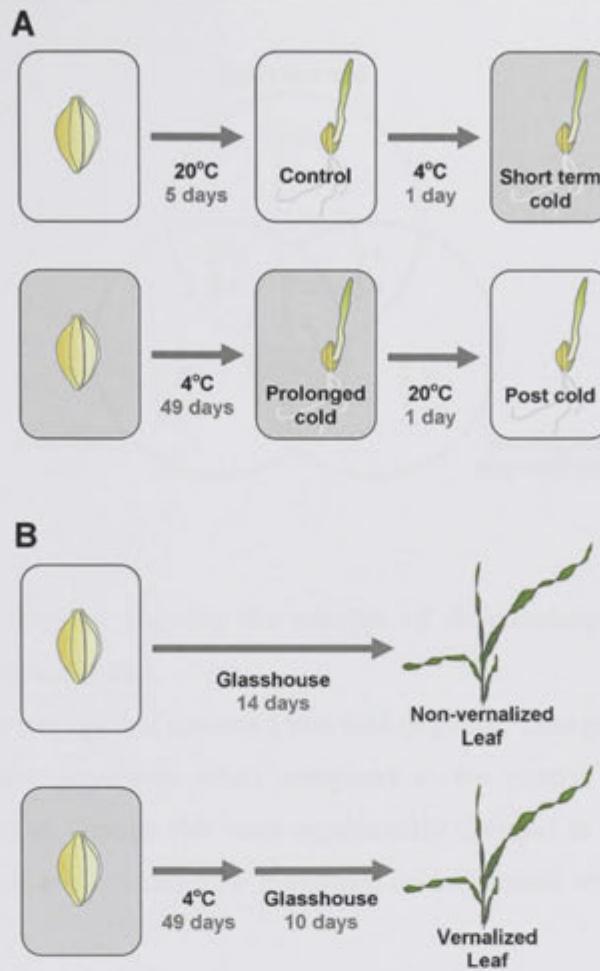

Figure 1. Overview of sampling methods for microarray analysis.

A) Barley seeds (cv. Sonja) were germinated and grown in darkness at either 20°C over 5 days (control) or 4°C over 49 days (prolonged cold). Seedlings were then either shifted from the control treatment to 4°C for 24 hours (short term cold) or shifted from the prolonged cold treatment to 20°C for 24 hours (post cold). In all treatments the shoot apex remained at an early stage of vegetative development, but plants grown from seedlings that experienced prolonged cold flower rapidly when shifted to normal growth temperatures, unlike control seedlings germinated at 20°C (Sasani et al., 2009). B) To identify contigs that show a sustained response to prolonged cold, barley seeds were germinated in the dark at 4°C for 49 days and then transferred to growth in glasshouse conditions until they reached the three leaf stage (10 days after the end of cold treatment). Non-vernalized control plants were grown simultaneously under the same conditions and were sampled at the equivalent developmental leaf stage (14 days). Shading indicates cold treatments.

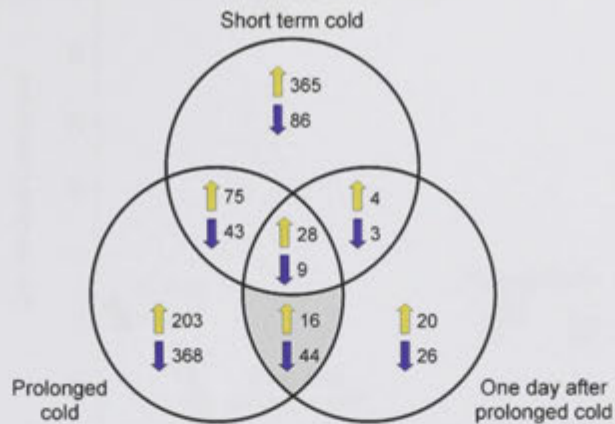

Figure 2. Venn diagram showing the number of differentially expressed contigs across the different treatments.

A summary of the contigs that showed a two fold or greater change in transcript levels across the different treatments when compared to the control treatment, $p < 0.01$. Shaded area indicates contigs that were significantly changed in the samples treated with prolonged cold and one day after prolonged cold treatment when compared to the control.

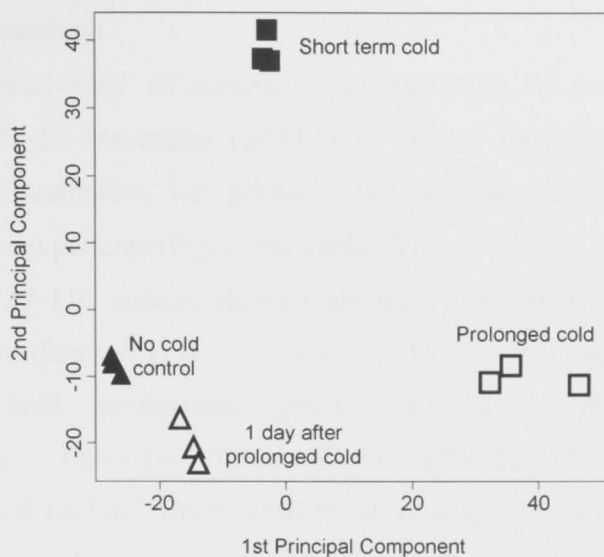

Figure 3. Principle component analysis of microarray data.

Principal component analysis was applied on differentially expressed contigs as described in methods. Closed triangles (▲) indicate samples from the no cold control treatment. Open triangles (△) represent the 1 day after prolonged cold treatment. Closed squares (■) represent the short term cold treatment. Open squares (□) represent the prolonged cold treatment. Replicate symbols represent biological replicates.

* This analysis was undertaken by Dr. Sally A Walford

K-means cluster analysis

Cluster analysis was used to compare the expression of contigs that showed significant changes in expression ($p < 0.01$) in any of the two way comparisons between seedling treatments. Ten primary clusters were identified, each showing distinctive expression patterns (Fig. 4 and Table S7).

A cluster of 114 contigs showed elevated expression at low-temperature, irrespective of the duration (Fig. 4, cluster 1). Contigs belonging to this cluster correspond to cold acclimation genes, such as *DEHYDRIN5 (DHN5)* (contig1717_s_at), *DELTA1-PYRROLINE-5-CARBOXYLATE SYNTHASE 1* (contig3814_at) and *GALACTINOL SYNTHASE* (contig3810_at and contig3811_at) (Table S7). A second cluster of 98 contigs (cluster 2) showed an inverse expression pattern, and is made up of contigs that are down-regulated by low-temperatures (Fig. 4, cluster 2). This cluster includes contigs corresponding to heat-shock genes (contig2006_s_at and contig5597_s_at) and a *PROLINE OXIDASE* (contig68_at) (Table S7).

A group of 85 contigs showed increased expression only in the short term cold treatment (Fig. 4, cluster 3). This cluster includes several contigs annotated as transcription factors, examples include: basic leucine zipper domain, Zinc finger domain, WRKY and NAC domain transcription factors. There were also several contigs annotated as *GLUTATHIONE-S-TRANSFERASE* (Table S7). Another cluster showed the inverse pattern to cluster 3 and was made up of 122 contigs (Fig. 4, cluster 4). This cluster includes contigs annotated as core histone domain containing proteins (contig175_at and contig175_x_at) as well as several basic helix-loop-helix transcription factors (contig4559_s_at, contig4560_at, contig4560_x_at and contig26382_at) (Table S7). Clusters 3 and 4 define contigs that respond to short term cold exposure or “cold shock”.

A group of 47 contigs showed elevated expression in the short term cold treatment, the prolonged cold treatment and the post cold sample (Fig. 4, cluster 5). Contigs belonging to this cluster include several contigs corresponding to cold acclimation genes (Table S7). Twenty three contigs showed elevated expression only in the post cold samples (Fig.4, cluster 6). This cluster includes heat-shock genes (contig2004_s_at and contig2007_s_at) and auxin or jasmonate responsive genes (contig17690_at and contig2906_at, HVSMEg0005M23r2_at respectively) (Table S7).

Contigs that showed elevated expression only in the prolonged cold treatment were grouped in cluster 7 (138 contigs) (Fig. 4). This cluster includes contigs corresponding to *FLOWERING LOCUS T-like2* (HVSMEI0003G02r2_at) and an *APETALLA2-like* gene (contig18652_at) (Table S7). Conversely, contigs that had decreased expression in prolonged cold treatment were grouped into cluster 8 (217 contigs) (Fig. 4). Examples from this cluster include contigs described as zinc finger transcription factors (contig4486_at and contig8233_s_at) and cysteine proteases (HB26O11r_at, HVSMEI0003G02r2_at and contig11505_at) (Table S7).

Of most interest to the aims of this study were contigs that showed a lasting response to prolonged cold. A cluster of 46 contigs had increased expression in the prolonged cold and post cold samples (Fig. 4, cluster 9). This cluster includes *VRNI* (rbaal14f06_s_at), contigs corresponding to *23kd JASMONATE INDUCED* genes (rbags15p13_s_at and contig1679_s_at), a putative glucan synthase (contig19065_at) and a calcium binding EF-hand protein (AJ250283_at) (Table S7). Another cluster of 73 contigs showed the inverse pattern, with decreased expression in the prolonged cold and post cold samples (Fig. 4, cluster 10). This group includes contigs corresponding to *HvODDSOC2* (*HvOS2*) (contig12031_at), Rubisco Activase (contig1019_at) and RNase S-like proteins (contig5059_s_at and contig5058_x_at) (Table S7).

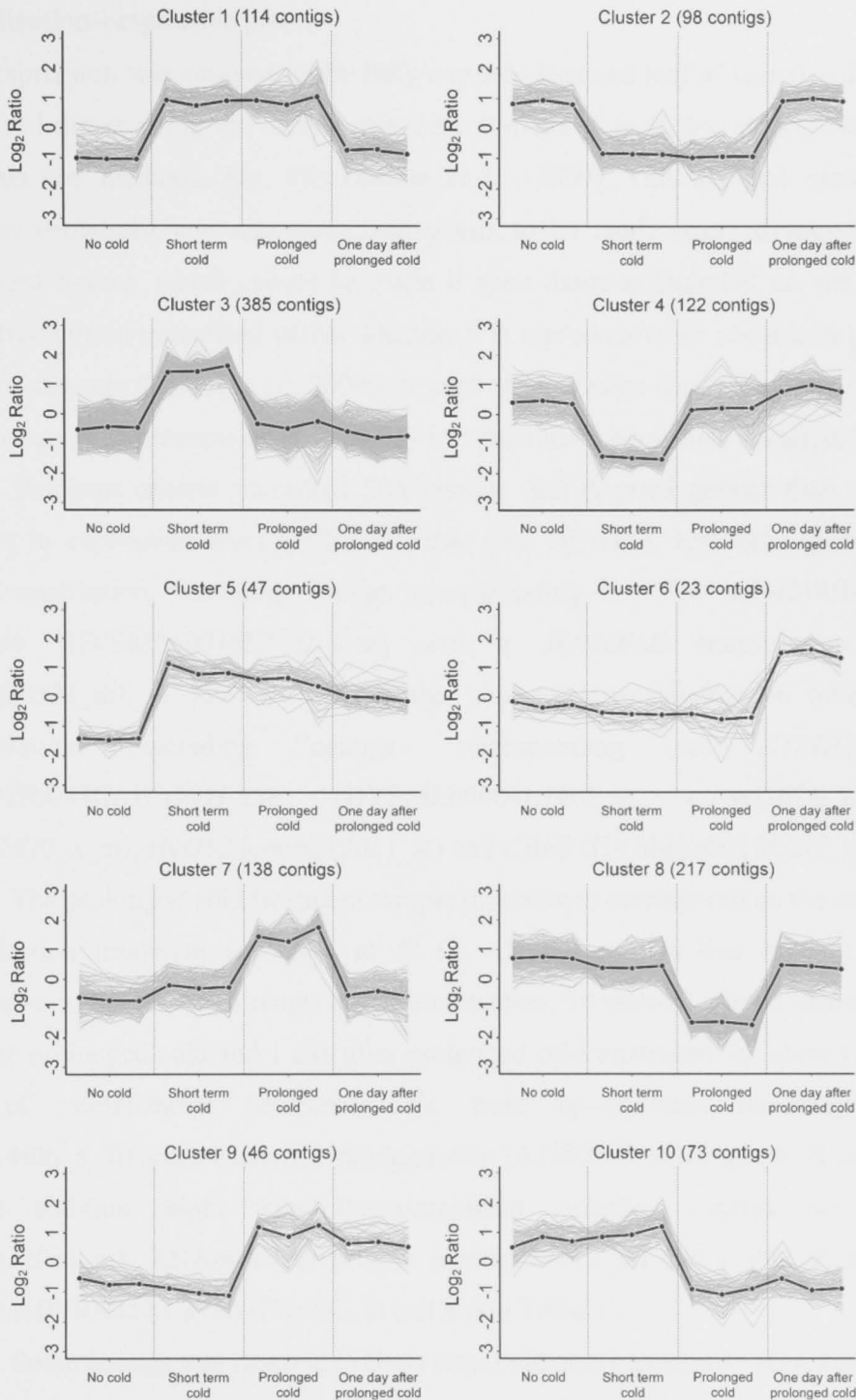

Figure 4. K-means cluster analysis of differentially expressed contigs.

The mean for each cluster is shown as black dots and lines and the gray lines represent the expression pattern of individual contigs. The three replicates for each treatment data are shown.

Vernalization-responsive genes

Gene expression was assayed in the fully expanded second leaf of vernalized or non-vernalized plants using the Affymetrix 22K Barley1 chip (Close et al., 2004) (see materials and methods, Fig. 1B) (Sasani et al., 2009). This allowed comparisons between vernalized and non-vernalized plants to be made using developmentally equivalent tissues, which cannot be made if apex tissue is included i.e. the apex is vegetative in non-vernalized plants whereas it is reproductive in vernalized plants at this growth stage (Sasani et al., 2009). A total of 60 contigs showed greater than two fold change in expression level ($p < 0.01$) in vernalized versus non-vernalized leaves. A less stringent criteria identified 244 contigs that showed greater than 1.5 fold changes in expression level ($p < 0.05$) (Table S8). Of these, 120 were up-regulated after vernalization, including contigs corresponding to *VRN1* (rbaal14f06_s_at), *COR14b* (HVSMEa0015E13r2_s_at) and a *JUMONJI* transcription factor (contig24321_at). A total of 128 contigs showed lower expression levels after vernalization, including contigs corresponding to *XYLOGLYCAN ENDOTRANGLYCOSYLASE* (HVSMEb0004L16r2_at, contig2673_at and contig2670_x_at), *HvOS2* (contig12031_at) and *CBF9* (HVSMEen0019L21f_at).

The prolonged cold treatment sample (see above) corresponds to the end of the vernalization treatment (49 days at 4° C). Of the contigs that showed altered expression in the leaves of plants after vernalization, 14 showed altered expression in both the prolonged cold and 1 day after prolonged cold treatments (clusters 9 and 10) (end of vernalization treatment): six were up-regulated including *VRN1* (rbaal14f06_s_at) and a calcium binding protein (AJ250283_at) (Fig. 5A, B and Table 1). In addition, eight were down-regulated including contigs for *HvOS2* (contig12031_at), RNase-S-like protein (contig5059_s_at) and a PR17d secretory protein (HW03O22u_s_at) (Fig. 5C, D and E and Table 1).

Some contigs that respond to short term cold also had altered expression in the leaves of vernalized plants. These include *COR14b* (HVSMEa0015E13r2_s_at) (Fig. 5F and Table S9), a cold acclimation protein WCS19 (baakp18_s_at) (Fig. 5G and Table S9) and a LEA-like protein (contig10150_at) (Fig. 5H and Table S9). Others did not show consistent expression patterns when the seedling treatments were compared to the leaf samples from plants after vernalization. *CBF9* (HVSMEen0019L21f_at) showed elevated expression after short term and prolonged cold but was down-regulated in the leaves of plants after vernalization (Fig. 5I and

Table S9). The expression pattern of these contigs is distinct to other contigs that are also cold regulated. For example, contigs corresponding to *DHN5* (contig1717_s_at and HVSMEa0006122r2_s_at) are also regulated by cold but show no change in expression in the leaves of vernalized plants (Fig. 5J). A full list of the contigs that changed under both experimental conditions is provided in Table S9.

Table 1. Contigs showing a maintained response to cold in the leaves of plants after vernalization.

Probe Set	Best Match (BLASTn and or BLASTp)	Fold Change	P Value
Cluster 9			
AJ250283_at	Calcium binding EF-hand protein (<i>Hordeum vulgare</i>)	11.39	5.90e ⁻⁰⁴
rbaal14f06_s_at	<i>VRN1</i> (MADS box gene)	6.12	2.63e ⁻⁰⁹
rbags15p13_s_at	Jasmonate induced protein (<i>Hordeum vulgare</i>)	5.43	1.47e ⁻⁰³
Contig1679_s_at	Jasmonate-induced protein (<i>Hordeum vulgare</i>)	1.81	1.33e ⁻⁰⁴
Contig372_s_at	unknown	1.70	1.69e ⁻⁰⁴
Contig19065_at	<i>glucan synthase-like 3</i> (<i>Hordeum vulgare</i>)	1.60	7.59e ⁻⁰⁴
Cluster 10			
Contig12031_at	<i>HvODDSOC2</i> (MADS box gene) (<i>Hordeum vulgare</i>)	-1.52	3.19e ⁻⁰³
Contig23272_at	serine acetyltransferase protein, putative	-1.55	1.07e ⁻⁰⁴
HS07112u_s_at	FAD binding domain containing protein / Monooxygenase	-1.58	3.72e ⁻⁰³
HE01015u_at	extracellular dermal glycoprotein (EDGP), putative	-1.67	3.60e ⁻⁰⁴
HVSMEf0015C12f_at	unknown	-1.68	1.13e ⁻⁰³
Contig5059_s_at	RNase S-like protein (<i>Hordeum vulgare</i>)	-1.73	5.94e ⁻⁰⁴
HW03O22u_s_at	PR17d (<i>Hordeum vulgare</i>) / secretory protein	-1.75	3.07e ⁻⁰³
Contig9743_at	unknown	-1.79	1.61e ⁻⁰³

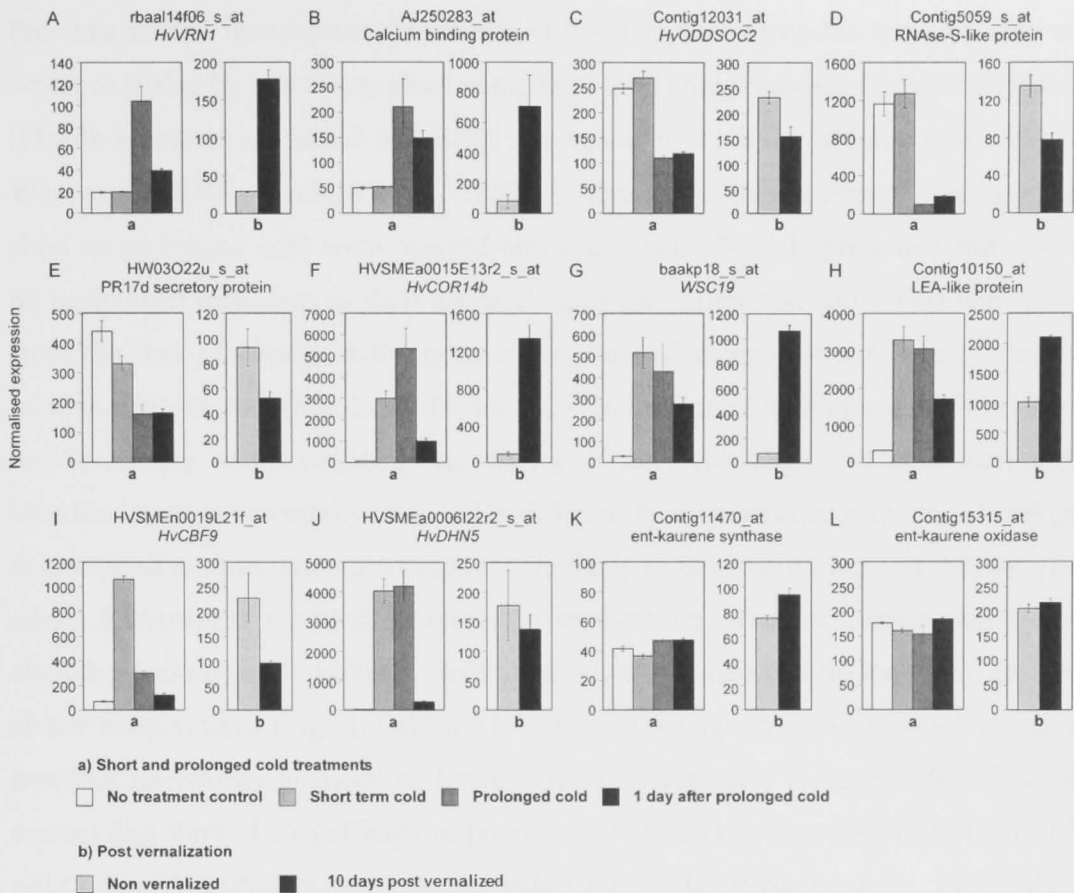

Figure 5. Examples of temperature responsive contigs.

The expression pattern from microarray experiments of individual contigs in response to short term cold, prolonged cold and one day after prolonged cold (a), as well as in the leaves of plants after vernalization (b).

Discussion

Previous studies investigated the effects of low-temperature on the transcriptome of wheat or barley by examining short to medium term cold responses (1 day - 2 weeks) (Plexdb accession no. BB65 and BB81; Svensson et al., 2006; Monroy et al., 2007; Wise et al., 2008; Winfield et al., 2010). In this study, transcriptional responses to short or prolonged cold were assayed and compared. The data presented show that transcriptional responses to short and prolonged cold differ markedly. This is evident from the lists of contigs with significantly changed expression for each treatment relative to the control (Fig. 2 and Tables S1-6) and is further highlighted by PCA (Fig. 3). Comparing and contrasting the effects of different lengths of cold treatment identified contigs potentially involved in different low-temperature responses. Contigs that respond to short term cold treatment are likely to function during cold “shock”, to adjust homeostasis to rapid decreases in temperature, whereas contigs that show altered expression after prolonged cold are likely to be important for long term growth at low temperatures (Fig. 4, Tables S1-6 and S7). Comparisons of this dataset with previous microarray analyses of low-temperature responses in barley identified 55 contigs that showed a significant response to cold in all experiments (8 down and 47 up) (Table S10) (Plexdb accession no. BB65 and BB81; Svensson et al., 2006; Wise et al., 2008). These contigs define a core set of low-temperature responsive genes from barley, including cold acclimation genes such as *DHN5* (Tommasini et al., 2008) (HVSMEa0006I22r2_s_at and contig1717_s_at) (Table S10).

In addition to contrasting the effects of short versus prolonged cold, gene expression was assayed one day after prolonged cold treatment. Amongst the large number of contigs represented on the Barley1 Affymetrix chip only a limited number showed a sustained response to prolonged cold after plants were shifted to warm conditions (Fig. 4, Clusters 9 and 10). This is highlighted by PCA, which showed that the transcriptome of seedlings first grown in the cold for 49 days then at 20°C for 24 hours is most similar to the transcriptome of seedlings that developed to an equivalent stage at 20°C (Fig. 3). Similarly, few of the contigs that showed altered expression in the prolonged cold treatment showed altered expression in the leaves of vernalized plants at the third leaf stage (10 days after the end of a prolonged cold treatment; 14 contigs, 6 up and 8 down) (Table 1). This observation is important with regards to the phenomenon of vernalization-induced flowering, since contigs that show a lasting response to prolonged cold potentially contribute to the acceleration of reproductive

development that occurs in vernalized plants (see Sasani et al., 2009). Indeed, the list of contigs identified as showing a sustained response to prolonged cold includes *VRN1*, a central regulator of the vernalization response in cereals (Trevaskis, 2010), validating this approach.

HvOS2 was identified amongst contigs that are down-regulated by vernalization (Fig 5C and Table 1). This is consistent with previous studies, which showed that *HvOS2*, and two closely related wheat genes, *Triticum aestivum* *AGAMOUS-like 33* and *42* (*TaAGL33*, *TaAGL42*), show reduced transcript levels during and after vernalization (Trevaskis et al., 2003, Winfield et al., 2009). Down-regulation of *HvOS2* in vernalized plants is likely to contribute to accelerated flowering (Greenup et al., 2010), and although *HvOS2* is down-regulated by cold independently of *VRN1*, maintained repression of *HvOS2* after vernalization requires *VRN1* (Greenup et al., 2010). Thus, down-regulation of *HvOS2* in the leaves of vernalized plants can be considered a consequence of *VRN1* expression. An *RNase S-like* gene (contig5059_s_at), which is up-regulated by *HvOS2* (Greenup et al., 2010), was down-regulated in the leaves of vernalized plants (Fig. 5D and Table 1). Although the function of this gene is not known, this expression pattern is consistent with the hypothesis that transcription of this gene is activated by *HvOS2*.

A number of other vernalization-responsive contigs were identified. These include a contig predicted to encode a calcium binding EF-hand protein (AJ250283_at), which showed increased expression after vernalization (Fig. 5B and Table 1). EF hand proteins act as calcium sensors that contribute to diverse biological processes, including hormone metabolism, cell signalling and gene expression (reviewed in DeFalco et al., 2010). Calcium signalling might play a role during short term cold responses and cold acclimation (Knight et al., 1996; Doherty et al., 2009). The identification of a vernalization-responsive gene encoding an EF-hand protein (contig AJ250283_at) suggests that altered calcium signalling might also play a role in the vernalization response of cereals.

Contigs corresponding to two 23kDa jasmonate induced proteins (rbags15p13_s_at and contig1679_s_at), which might regulate cell wall polysaccharide synthesis (Oikawa et al., 2009), were induced by vernalization, as was a contig corresponding to a glucan synthase (contig19065_at) (Table 1). Conversely, a contig corresponding to a FAD binding domain containing protein (HS07I12u_s_at) was down-regulated (Table 1). Altered transcript levels for these contigs might reflect

adjustment of metabolism in vernalized plants to facilitate the transition to reproductive growth. Alternatively, metabolism might adjust to compensate for changes in metabolite pools that occur during prolonged growth at low-temperature, which would not occur in control seedlings germinated at 20°C.

A previous microarray study investigating seasonal flowering responses in wheat showed transcript levels for key enzymes in the gibberellin biosynthesis pathway, ent-kaurene synthase and ent-kaurene oxidase, increase during step wise decreases in both temperature and photoperiod (Winfield et al., 2009). We found no evidence that these enzymes play a role in the vernalization response of barley seedlings; expression levels of *ENT-KAURENE SYNTHASE* (contig11470_at) and *ENT-KAURENE OXIDASE* (contig15315_at) remained at similar levels during and after vernalization (Fig. 5K and L). The different findings of this study versus that of Winfield et al. (2009) might be due to the conditions used in each study; decreasing daylength versus darkness, or the age of plants examined (mature plants versus seedlings). Regardless, changes in transcript levels of these gibberellin biosynthetic enzymes are probably not required for the early stages of the vernalization response in barley seedlings. This does not rule out important roles for these genes in regulating responses to different temperature and daylength combinations, as suggested by Winfield et al. (2009), but highlights the advantage of using seedling vernalization as an experimental system; the effects of low-temperature can be separated from the effects of development or daylength. This is important because *sensu stricto* vernalization is a response to cold (Gassner, 1918; Purvis, 1934; Chouard, 1960). Furthermore, separating the effects of different seasonal flowering cues allows better prediction of physiological responses in complex environments.

Some contigs that have a rapid response to cold also show altered expression following prolonged cold treatment. For example, *COR14b* (HVSMEa0015E13r2_s_at) and the related gene *WCS19* (baak1p18_s_at) were induced by short term, similar to previous studies (Vágújfalvi et al., 2000, Stockinger et al., 2007 and Tommasini et al., 2008). These genes were also activated by prolonged cold treatment and expression remained high in seedlings a day after prolonged cold treatment and in the leaves of vernalized plants (Fig. 5G and Table S9). This contrasts with the behaviour of most other cold responsive genes, *DHN5* for example, which returns to expression levels equivalent to the control treatment when plants are grown in warm temperatures after prolonged cold (Fig. 5J and Table S9).

The COR14b and WCS19 proteins localise to the chloroplast, possibly to reduce photo-oxidative stress (Gray et al., 1997; Crosatti et al., 1999), but it is unclear why expression of these contigs is maintained after cold treatment. The lasting change in expression of these contigs following prolonged exposure to cold could be mediated by changes in chromatin state. Cold induced histone modifications are maintained at the promoters of some cold responsive genes in *Arabidopsis thaliana*, which may act as a memory marker for cold exposure (Kwon et al., 2009).

Two contigs corresponding to *CBF* genes were expressed at lower levels in the leaves of vernalized plants; *CBF2* (AF442489_at) and *CBF9* (HVSME0019L21f_at) (Fig. 5I and Table S9). Reduced expression of these contigs in the leaves of vernalized plants, which are beginning reproductive growth at the time point sampled (Sasani et al., 2009), might contribute the reduced capacity for cold acclimation that is associated with the transition to reproductive growth in cereals (Fowler et al., 1996, Limin and Fowler, 2002). Similar *CBF* genes in *T. monococcum* show elevated expression during cold acclimation in a *T. monococcum VRN1* deletion mutant that does not progress towards reproductive growth (*maintained vegetative phase*). This is consistent with the hypothesis that the transition to reproductive growth limits the expression of these genes (Dhillon et al., 2010). It might be possible to alter the expression of these *CBF* genes to engineer increased frost tolerance during reproductive growth, through over-expression in transgenic plants for example.

In conclusion, we have identified barley genes that respond to prolonged cold and show lasting changes in transcriptional activity when plants are shifted to normal growth conditions. The observation that only a limited number of contigs show lasting responses to prolonged cold, at least within the detection limits of microarray analysis, highlights the importance of *VRN1* in the vernalization response of temperate cereals. A key question for further research is how does prolonged cold lead to increased *VRN1* expression? By identifying genes that are differentially expressed during short and prolonged cold we have begun to address this question.

Materials and Methods

Plant Growth

To compare the effects of short and prolonged cold on transcription in barley (cv. Sonja; a well characterised vernalization-responsive barley (Sasani et al., 2009) seeds with the genotype: *HvVRN1*, *HvVRN2*, *PPD-H1*, *ppd-H2* were germinated and grown

in darkness to an average coleoptile length of 4 cm at either 20°C over 5 days (control) or 4°C over 49 days (prolonged cold). Seedlings were then shifted from the control treatment to 4°C for 24 hours (short term cold) or shifted from the prolonged cold treatment to 20°C for 24 hours (post cold) (Fig. 1A). In all treatments the shoot apex remained at an early stage of vegetative development, but plants grown from seedlings that experienced prolonged cold flower rapidly when shifted to normal growth temperatures, unlike control seedlings germinated at 20°C (Sasani et al., 2009). Whole seedlings were harvested from each treatment for RNA extraction and gene expression was assayed using the Affymetrix 22K Barley1 chip (Close et al., 2004).

To examine gene expression after prolonged cold, barley plants (*Hordeum vulgare*) (cv. Sonja) were grown in pots covered in foil at 4°C for 49 days. The foil was then removed from pots and plants were grown in a glasshouse (18 ± 2°C) in long days (16-h light/8-h dark), with supplementary light when natural levels dropped below 200µE until they reached the three leaf stage (10 days) (Fig. 1B). Non treatment control plants were grown at the same time under the same conditions and were sampled at the equivalent developmental leaf stage (Fig. 1B). The fully expanded second leaf (no sheath) was harvested for RNA extraction.

Microarray analysis

RNA was extracted using the method of Chang et al. (1993) and then further purified using RNeasy columns (Qiagen). Probe synthesis, labelling, hybridisation to the Barley1 Gene chip (Close et al., 2004) and RNA quality were conducted at the Australian Genome Research Facilities (AGRF, Melbourne, VIC, Australia), following the manufacturer's recommendations (Affymetrix, Santa Clara, CA). Microarray analyses were performed on 3 biological replicates of each treatment. The resulting dataset was analysed in R v2.7.0 and analysed using packages from Bioconductor ((Gentleman et al., 2004), <http://www.bioconductor.org/>), using default settings. Normalisation was carried out by Robust Multichip Analysis (RMA) and differentially expressed contigs were identified across the normalised microarray datasets for biological replicates using linear modelling in limma in R v2.7.1 (Linear Models for Microarray Data) (Smyth, 2005). Each experimental sample was compared with the control sample (e.g. Short Cold vs Control) and multiple testing was corrected for by controlling the False Discovery Rate (Benjamini, 1995). For

PCA clustering, genes that were differentially expressed in any of the three seedling treatments relative to the control (empirical Bayes test, no minimum fold change cut off applied; 11057 contigs) were grouped based on condition using the 'cluster.samples' function in smida (R v.2.7.1) (Wit and McClure, 2004). The method chosen was 'pca' and 'euclidean' was selected as the distance measured. The clusters were plotted using the first two principal components from the PCA analysis. Comparisons between lists of contigs with significantly changed expression in the different treatments and the generation of preliminary Venn diagrams was performed using the FiRe macro in Excel® (Garcion et al., 2006). Raw microarray data has been deposited in the Plant Expression Database (www.plexdb.org), a MIAME/Plant Compliant Gene Expression Resources for Plants and Plant Pathogens (Experiments BB94 and BB95).

K-means Clustering

K-means cluster analysis was performed on contigs that showed a two fold or greater change in transcript levels ($p < 0.01$) from two-way comparisons between the different treatments. Cluster analysis was performed using the MeV software from the TM4 microarray software suite using the default settings (Euclidean distance, and a maximum of 50 iterations) (Saeed et al., 2003; Saeed et al., 2006).

qRT-PCR Gene Expression Analysis

Total RNA was extracted using the method of Chang et al. (1993) or the Qiagen RNeasy Plant Miniprep kit (Qiagen). cDNA was synthesised for qRT-PCR by using an oligo(T) primer (5'T18[G/C/A]) to prime first-strand complementary DNA (cDNA) synthesis from 1-5 µg of total RNA with SuperScript III reverse transcriptase enzyme (Invitrogen). qRT-PCR was performed on a Rotor-Gene 3000 real-time cycler (Corbett Research). The primers used for *HvACTIN*, *HvVRN1* and *HvOS2* have been described previously (Trevaskis et al., 2006; Greenup et al., 2010). The sequences of primers used for contig6358_at were as follows: forward 5' TCCTCGTGTGATTTTGCAG 3' and reverse 5' TTGAGTTCAGCGATGCTACG 3' and for HU14M19u_at: forward 5' TCAAAAAGGATGCCCAAAG 3' and reverse 5' AACAAAGCTTGGCAAACACA 3'. qRT-PCR was performed using Platinum Taq DNA polymerase (Invitrogen) with SYBR green. Cycling conditions were 4 minutes at 94°C, 40 cycles of 10 s at 95°C, 15 s at 60°C, and 20 s at 72°C, followed

by a melting-curve program (72°C–95°C with a 5-s hold at each temperature). Fluorescence data were acquired at the 72°C step and during the melting-curve program. Expression levels of genes of interest were calculated relative to *ACTIN* using the comparative quantification analysis method (Rotogene-5; Corbett Research), which takes into account the amplification efficiency of each primer set. Data presented are averages of a minimum of three biological replicates unless stated otherwise and the error bars show standard error.

Literature Cited

- Benjamini YaH, Y** (1995) Controlling the false discovery rate: a practical and powerful approach to multiple testing. *Journal of the Royal Statistical Society, Series B (Statistical Methodology)*.
- Chang S, Puryear J, Cairney J** (1993) A simple and efficient method for isolating RNA from pine trees. *Plant Molecular Biology Reporter* **11**: 113-116.
- Chouard P** (1960) Vernalization and its relations to dormancy. *Annual Review of Plant Physiology* **11**: 191-238.
- Close TJ, Wanamaker SI, Caldo RA, Turner SM, Ashlock DA, Dickerson JA, Wing RA, Muehlbauer GJ, Kleinhofs A, Wise RP** (2004) A new resource for cereal genomics: 22K Barley GeneChip comes of age. *Plant Physiology* **134**: 960-968.
- Crosatti C, de Laureto PP, Bassi R, Cattivelli L** (1999) The interaction between cold and light controls the expression of the cold-regulated barley gene *cor14b* and the accumulation of the corresponding protein. *Plant Physiology* **119**: 671-680.
- Danyluk J, Kane NA, Breton G, Limin AE, Fowler DB, Sarhan F** (2003) *TaVRT-1*, a putative transcription factor associated with vegetative to reproductive transition in cereals. *Plant Physiology* **132**: 1849-1860.
- DeFalco TA, Bender KW, Snedden WA** (2010) Breaking the code: Ca²⁺ sensors in plant signalling. *Biochemical Journal* **425**: 27-40.
- Dhillon T, Pearce SP, Stockinger EJ, Distelfeld A, Li CX, Knox AK, Vashegyi I, Vagujfalvi A, Galiba G, Dubcovsky J** (2010) Regulation of freezing tolerance and flowering in temperate cereals: The *VRN-1* connection. *Plant Physiology* **153**: 1846-1858.

- Doherty CJ, Van Buskirk HA, Myers SJ, Thomashow MF** (2009) Roles for Arabidopsis CAMTA transcription factors in cold-regulated gene expression and freezing tolerance. *Plant Cell* **21**: 972-984.
- Entz MH, Fowler DB** (1991). Agronomic performance of winter versus spring wheat. *Agronomy Journal* **83**: 527–532.
- Fowler DB, Chauvin LP, Limin AE, Sarhan F** (1996) The regulatory role of vernalization in the expression of low-temperature-induced genes in wheat and rye. *Theoretical and Applied Genetics* **93**: 554-559.
- Galiba G, Vagujfalvi A, Li CX, Soltesz A, Dubcovsky J** (2009) Regulatory genes involved in the determination of frost tolerance in temperate cereals. *Plant Science* **176**: 12-19.
- Garcion C, ApplimathFri, Métraux J-P** (2006) FiRe and microarrays: a fast answer to burning questions. *Trends in Plant Science* **11**: 320-322.
- Gassner G** (1918) Beitrage zur physiologischen Charakteristik sommer- und winterannueller Gewaechse in besondere der Getreidepflanzen. *Zeitschrift fuer botanik* **10**: 27-476.
- Gentleman R, Carey V, Bates D, Bolstad B, Dettling M, Dudoit S, Ellis B, Gautier L, Ge Y, Gentry J, Hornik K, Hothorn T, Huber W, Iacus S, Irizarry R, Leisch F, Li C, Maechler M, Rossini A, Sawitzki G, Smith C, Smyth G, Tierney L, Yang J, Zhang J** (2004) Bioconductor: open software development for computational biology and bioinformatics. *Genome Biology* **5**: R80.
- Gott MB, Gregory FG, Purvis ON** (1955) Studies in vernalization of cereals VIII. Photoperiodic control of stage in flowering between initiation and ear formation in vernalised and unvernalsed petkus winter rye. *Annals of Botany* **21**: 87.
- Gray GR, Chauvin LP, Sarhan F, Huner NPA** (1997) Cold acclimation and freezing tolerance - A complex interaction of light and temperature. *Plant Physiology* **114**: 467-474.
- Greenup AG, Sasani S, Oliver SN, Talbot MJ, Dennis ES, Hemming MN, Trevaskis B** (2010) *ODDSOC2* is a MADS box floral repressor that is down-regulated by vernalization in temperate cereals. *Plant Physiology* **153**: 1062-1073.

- Hayes PM, Blake T, Chen THH, Tragoonrung S, Chen F, Pan A, Liu B** (1993) Quantitative trait loci on barley (*Hordeum vulgare* L) chromosome 7 associated with components of winter hardiness. *Genome* **36**: 66-71.
- Hemming MN, Peacock WJ, Dennis ES, Trevaskis B** (2008) Low-temperature and daylength cues are integrated to regulate *FLOWERING LOCUS T* in barley. *Plant Physiology* **147**: 355-366.
- King RW, Heide OM** (2009) Seasonal flowering and evolution: the heritage from Charles Darwin. *Functional Plant Biology* **36**: 1027-1036.
- Knight H, Trewavas AJ, Knight MR** (1996) Cold calcium signalling in Arabidopsis involves two cellular pools and a change in calcium signature after acclimation. *Plant Cell* **8**: 489-503.
- Knox AK, Li CX, Vagujfalvi A, Galilba G, Stockinger EJ, Dubcovsky J** (2008) Identification of candidate *CBF* genes for the frost tolerance locus *Fr-A(m)2* in *Triticum monococcum*. *Plant Molecular Biology* **67**: 257-270.
- Koemel JE, Guenzi AC, Anderson JA, Smith EL** (2004) Cold hardiness of wheat near-isogenic lines differing in vernalization alleles. *Theoretical and Applied Genetics* **109**: 839-846.
- Kwon C, Lee D, Choi G, Chung W** (2009) Histone occupancy-dependent and -independent removal of H3K27 trimethylation at cold-responsive genes in Arabidopsis. *Plant Journal* **60**: 112-121.
- Limin AE, Fowler DB** (2002) Developmental traits affecting low-temperature tolerance response in near-isogenic lines for the vernalization locus *Vrn-A1* in wheat (*Triticum aestivum* L. *em Thell*). *Annals of Botany* **89**: 579-585.
- Limin AE, Fowler DB** (2006) Low-temperature tolerance and genetic potential in wheat (*Triticum aestivum* L.): response to photoperiod, vernalization and plant development. *Planta* **224**: 360-366.
- Monroy AF, Dryanova A, Malette B, Oren DH, Farajalla MR, Liu W, Danyluk J, Ubayasena LWC, Kane K, Scoles GJ, Sarhan F, Gulick PJ** (2007) Regulatory gene candidates and gene expression analysis of cold acclimation in winter and spring wheat. *Plant Molecular Biology* **64**: 409-423.
- Oikawa A, Nagai K, Kato K, Kidou S** (2009) Gene silencing of barley *P23k* involved in secondary wall formation causes abnormal tiller formation and intercalary elongation. *Breeding Science* **59**: 664-670.

- Oliver SN, Finnegan EJ, Dennis ES, Peacock WJ, Trevaskis B** (2009) Vernalization-induced flowering in cereals is associated with changes in histone methylation at the *VERNALIZATION1* gene. *Proceedings of the National Academy of Sciences of the United States of America* **106**: 8386-8391.
- Purvis ON** (1934) An analysis of the influence of temperature during germination on the subsequent development of certain winter cereals and its relation to the effect of length of day. *Annals of Botany* **48**: 919-955.
- Roberts DWA** (1990) Identification of loci on chromosome 5A of wheat involved in control of cold hardiness, vernalization, leaf length, rosette growth habit and height of hardened plants. *Genome* **33**: 247-259.
- Saeed AI, Bhagabati NK, Braisted JC, Liang W, Sharov V, Howe EA, Li J, Thiagarajan M, White JA, Quackenbush J, Alan K, Brian O** (2006) [9] TM4 microarray software suite. *In Methods in Enzymology*, Volume **411**. Academic Press, pp 134-193.
- Saeed AI, Sharov V, White J, Li J, Liang W, Bhagabati N, Braisted J, Klapa M, Currier T, Thiagarajan M, Sturn A, Snuffin M, Rezantsev A, Popov D, Ryltsov A, Kostukovich E, Borisovsky I, Liu Z, Vinsavich A, Trush V, Quackenbush J** (2003) TM4: A free, open-source system for microarray data management and analysis. *Biotechniques* **34**: 374-378.
- Sasani S, Hemming MN, Oliver SN, Greenup A, Tavakkol-Afshari R, Mahfoozi S, Poustini K, Sharifi H-R, Dennis ES, Peacock WJ, Trevaskis B** (2009) The influence of vernalization and daylength on expression of flowering-time genes in the shoot apex and leaves of barley (*Hordeum vulgare*). *Journal of Experimental Botany*. **60**: 2169-2178.
- Smyth G** (2005) limma: Linear Models for Microarray Data. *In Bioinformatics and Computational Biology Solutions Using R and Bioconductor*. Springer, New York, pp 397-420.
- Stockinger EJ, Skinner JS, Gardner KG, Francia E, Pecchioni N** (2007) Expression levels of barley *CBF* genes at the *Frost resistance-H2* locus are dependent upon alleles at *Fr-H1* and *Fr-H2*. *Plant Journal* **51**: 308-321.
- Svensson JT, Crosatti C, Campoli C, Bassi R, Stanca AM, Close TJ, Cattivelli L** (2006) Transcriptome Analysis of Cold Acclimation in Barley Albina and Xantha Mutants. *Plant Physiology*. **141**: 257-270.

- Takahashi R, Yasuda S** (1971) Genetics of earliness and growth habit in barley. *In* RA Nilan, ed, Barley Genetics II (Proceedings of the Second International Barley Genetics Symposium). Washington State University Press, pp 388-408.
- Thomashow MF** (1999) Plant Cold Acclimation: Freezing Tolerance Genes and Regulatory Mechanisms. *Annual Review of Plant Physiology and Plant Molecular Biology* **50**: 571-599.
- Tommasini L, Svensson JT, Rodriguez EM, Wahid A, Malatrasi M, Kato K, Wanamaker S, Resnik J, Close TJ** (2008) *Dehydrin* gene expression provides an indicator of low temperature and drought stress: transcriptome-based analysis of barley (*Hordeum vulgare* L.). *Functional and Integrative Genomics* **8**:387-405.
- Trevaskis B** (2010) The central role of the *VERNALIZATION1* gene in the vernalization response of cereals. *Functional Plant Biology* **37**: 479-487.
- Trevaskis B, Bagnall DJ, Ellis MH, Peacock WJ, Dennis ES** (2003) MADS box genes control vernalization-induced flowering in cereals. *Proceedings of the National Academy of Sciences of the United States of America* **100**: 13099-13104.
- Trevaskis B, Hemming MN, Peacock WJ, Dennis ES** (2006) *HvVRN2* responds to daylength, whereas *HvVRN1* is regulated by vernalization and developmental status. *Plant Physiology*. **140**: 1397-1405.
- Vagujfalvi A, Crosatti C, Galiba G, Dubcovsky J, Cattivelli L** (2000) Two loci on wheat chromosome 5A regulate the differential cold-dependent expression of the *cor14b* gene in frost-tolerant and frost-sensitive genotypes. *Molecular Genetics and Genomics* **263**: 194-200.
- Winfield MO, Lu CG, Wilson ID, Coghill JA, Edwards KJ** (2009) Cold and light induced changes in the transcriptome of wheat leading to phase transition from vegetative to reproductive growth. *BMC Plant Biology* **9**:55 doi:10.1186/1471-2229-9-55.
- Winfield MO, Lu CG, Wilson ID, Coghill JA, Edwards KJ** (2010) Plant responses to cold: transcriptome analysis of wheat. *Plant Biotechnology Journal* **8**: 749-771.
- Wise RP, Caldo RA, Hong L, Shen L, Cannon E, Dickerson JA** (2008) BarleyBase/PLEXdb. *In* D Edwards, ed, *Plant Bioinformatics*, Vol **406**. Humana Press, Totowa, NJ., pp 347-363.

Wit E, McClure J (2004) Statistics for Microarrays: Design, Analysis and Inference. Wiley, Chichester.

Yan L, Loukoianov A, Tranquilli G, Helguera M, Fahima T, Dubcovsky J (2003) Positional cloning of the wheat vernalization gene *VRN1*. Proceedings of the National Academy of Sciences of the United States of America **100**: 6263-6268.

Supplemental Data

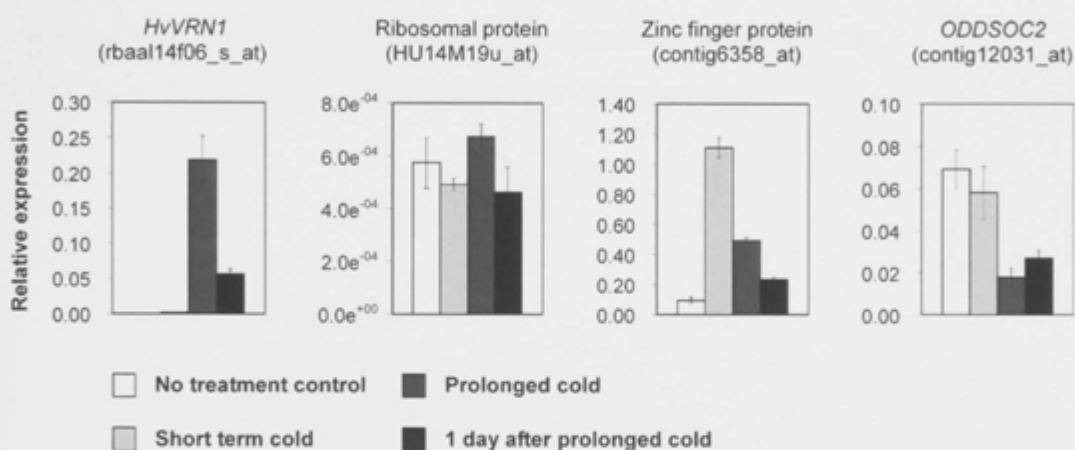

Supplemental Figure 1. Verification of gene expression pattern of selected contigs from microarray analysis. Expression levels of contigs were assayed by qRT-PCR, in barley seedlings from the treatments outlined in Figure 1. Error bars show SE.

Supplemental Tables 1 - 11 are contained on the attached CD in Microsoft excel format.

Table S1. Contigs with altered expression in the short cold treatment relative to no treatment control.

Table S2. Contigs with altered expression in the prolonged cold treatment relative to the no treatment control.

Table S3. Contigs with altered expression 1 day after prolonged cold treatment relative to the no treatment control.

Table S4. Contigs with altered expression in the prolonged cold treatment relative to the short cold treatment

Table S5. Contigs with altered expression after one day after prolonged cold relative to short cold treatment.

Table S6. Contigs with altered expression in the prolonged cold treatment relative to one day after prolonged cold treatment.

Table S7. Numbers and descriptions of contigs clustered together according to expression behaviour.

Table S8. Contigs with altered expression in the leaves of barley plants after vernalization.

Table S9. Contigs represented in primary cluster analysis with altered expression in the leaves of barley plants after vernalization.

Table S10. A core set of low-temperature responsive contigs in barley.

Table S11. Contigs omitted from top the ten main clusters.



Chapter 3

***ODDSOC2* is a MADS box floral repressor that is down-regulated by vernalization in temperate cereals**

Plant Physiology 153: 1062-1073 (2010)

Abstract

In temperate cereals, such as wheat and barley, the transition to reproductive development can be accelerated by prolonged exposure to cold (vernalization). We examined the role of the grass-specific MADS box gene *ODDSOC2* (*OS2*) in the vernalization response in cereals. The barley (*Hordeum vulgare*) *OS2* gene (*HvOS2*) is expressed in leaves and shoot apices but is repressed by vernalization. Vernalization represses *OS2* independently of *VERNALIZATION1* (*VRN1*) in a *VRN1* deletion mutant of einkorn wheat (*Triticum monococcum*), but *VRN1* is required to maintain down-regulation of *OS2* in vernalized plants. Furthermore, barleys that carry active alleles of the *VRN1* gene (*HvVRN1*) have reduced expression of *HvOS2*, suggesting that *HvVRN1* down-regulates *HvOS2* during development. Constitutive over-expression of *HvOS2* delayed flowering and reduced spike, stem and leaf length in transgenic barley plants. Plants constitutively over-expressing *HvOS2* showed reduced expression of barley homologues of the Arabidopsis (*Arabidopsis thaliana*) gene *FLORAL PROMOTING FACTOR 1* (*FPF1*) and increased expression of *RNase-S-like* genes. *FPF1* promotes floral development and enhances cell elongation, so down-regulation of *FPF1-like* genes might explain the phenotypes of *HvOS2* over-expression lines. We present an extended model of the genetic pathways controlling vernalization-induced flowering in cereals, which describes the regulatory relationships between *VRN1*, *OS2* and *FPF1-like* genes. Overall these findings highlight differences and similarities between the vernalization responses of temperate cereals and the model plant Arabidopsis.

Introduction

Many plants from temperate climates require prolonged exposure to low temperatures to become competent to flower; a phenomenon known as vernalization. The requirement for vernalization is often combined with daylength sensitivity. For example, many ecotypes of *Arabidopsis* (*Arabidopsis thaliana*) are vernalized during winter, and then flower as daylength increases during spring (Imaizumi and Kay, 2006; Jaeger et al., 2006; Zeevaart, 2006; Turck et al., 2008). Similar seasonal flowering responses are found in economically important cereal crop species including wheat (*Triticum aestivum*) and barley (*Hordeum vulgare*) (Trevaskis et al., 2007a; Distelfeld et al., 2009; Greenup et al., 2009).

In *Arabidopsis*, the promotion of flowering by increasing daylength is mediated by *FLOWERING LOCUS T (FT)* (Kardailsky et al., 1999; Kobayashi et al., 1999). *FT* encodes a mobile florigen which is produced in the leaves in long days and travels to the shoot apex where it promotes floral development (Corbesier et al., 2007). Long-day induction of *FT* in the leaves is controlled by the *CONSTANS (CO)* protein (Onouchi et al., 2000; An et al., 2004). Expression of the *CO* transcript follows a diurnal rhythm, peaking in the late afternoon (Valverde et al., 2004; Jang et al., 2008). In long-days the peak in *CO* expression occurs in light, which stabilises the *CO* protein, allowing activation of *FT* (Valverde et al., 2004; Jang et al., 2008).

Winter annual ecotypes of *Arabidopsis* do not flower rapidly in long days unless plants have been vernalized. This requirement for vernalization is mediated by the MADS box floral repressor *FLOWERING LOCUS C (FLC)* (Michaels and Amasino, 1999; Sheldon et al., 1999), which represses *FT* and a second floral promoter *SUPPRESSOR OF OVEREXPRESSION OF CONSTANS1 (SOC1)* (Michaels and Amasino, 1999; Sheldon et al., 1999; Hepworth et al., 2002; Michaels et al., 2005). Vernalization down-regulates *FLC*, allowing long-day induction of *FT* and *SOC1* to accelerate flowering. Vernalization-induced repression of *FLC* is mediated by protein complexes that chemically modify histones at the *FLC* locus to promote an inactive chromatin state (Schubert et al., 2006; Wood et al., 2006; De Lucia et al., 2008). The repressive histone modifications deposited at *FLC* chromatin during vernalization are stable, so repression of *FLC* is maintained post-vernalization; this allows long-day induction of *FT* to occur in spring in vernalized plants (Sheldon et al., 2000).

The molecular mechanisms that promote flowering in response to long days in *Arabidopsis* are conserved in temperate cereals. For instance, *CO* and *FT-like* genes have been identified in barley and related grasses (Turner et al., 2005; King et al., 2006; Yan et al., 2006; Faure et al., 2007). The barley *FT-like 1* gene (*FT1* or *VRN3*) is induced by long days and appears to be the functional equivalent of *FT* in cereals (Turner et al., 2005; King et al., 2006; Yan et al., 2006; Faure et al., 2007). As is the case for *FT* in vernalization-requiring *Arabidopsis* ecotypes, vernalization is a prerequisite for long-day induction of *FT1* in vernalization responsive barleys (Hemming et al., 2008). No homologues of *FLC* have been identified in cereals. Instead, *VERNALIZATION2* (*VRN2*) is expressed in long-days to suppress induction of *FT1* and delay flowering prior to vernalization (Takahashi and Yasuda, 1971; Yan et al., 2004; Trevaskis et al., 2006). Vernalization induces expression of *VERNALIZATION1* (*VRN1*) (Danyluk et al., 2003; Trevaskis et al., 2003; Yan et al., 2003; von Zitzewitz et al., 2005), which down-regulates *VRN2* and promotes expression of *FT1* in long days (Trevaskis et al., 2006; Yan et al., 2006; Hemming et al., 2008; Sasani et al., 2009). *VRN1* also promotes inflorescence (spike) initiation at the shoot apex, irrespective of daylength (Trevaskis et al., 2006; Hemming et al., 2008; Sasani et al., 2009). Like *FLC*, changes in chromatin state at the *VRN1* locus might provide a mechanism for a memory of vernalization in cereals by allowing stable activation of *VRN1* by vernalization (Oliver et al., 2009).

The vernalization response has probably evolved independently in *Arabidopsis* and the temperate cereals (grasses). Here we examine the function of a grass-specific MADS box gene previously identified by gene expression analyses as a potential component of the vernalization response in cereals (*Triticum aestivum* MADS box gene 23 - *TaMx23*, Trevaskis et al., 2003; also known as *Triticum aestivum* *AGAMOUS-like 33* - *TaAGL33*, Winfield et al., 2009). We show that this gene represses flowering and cell elongation by down-regulating a group of genes related to the *FLOWERING PROMOTER FACTOR1* (*FPF1*) gene of *Arabidopsis*.

Results

***ODDSOC2* is a truncated MADS box gene found in cereals and related grasses.**

Two barley homologues of *TaMx23* (Trevaskis et al., 2003) were identified amongst barley ESTs deposited in the GENBANK database. These genes have no direct equivalent in *Arabidopsis*, but show weak similarity to *SUPPRESSION OF*

OVEREXPRESSION OF CONSTANS1 (SOC1) (Supplemental Table 1, Supplemental Fig. 1). These genes were designated *ODDSOC1 (HvOS1)* and *ODDSOC2 (HvOS2)*. *ODDSOC-like* genes also occur in a range of cereals other than barley, including wheat, rice, maize and sorghum, and in the model grass *Brachypodium distachyon* (Table 1, Supplemental Table 2). All genes share a high degree of sequence identity (Supplemental Fig. 2A-C). A feature common to the predicted *ODDSOC-like* protein sequences is their short length compared to other plant MADS box proteins (152-167 versus ≥ 200 amino acids). No *ODDSOC-like* genes were identified outside the grasses.

The two *ODDSOC* genes from *Brachypodium* are closely linked to one another in a region syntenous to barley chromosome 3H (long arm, 134 cM) (Fig. 1A). A single *ODDSOC* gene is found in the rice genome (*OsMADS51*, Kim et al., 2007), located in a syntenous region (Fig. 1A). Phylogenetic analysis showed that *OS-like* genes can be classified into three groups, *OS1* or *OS2* groups in the temperate cereals/grasses plus a third group corresponding to maize, sorghum and rice (Fig. 1B), suggesting these genes have undergone gene duplication during the evolution of the temperate grasses.

Table 1. Non-redundant BLASTp results for HvOS2

Protein Description	Accession	Organism	Identity from BLASTp	BLAST Score	E-value
TaAGL33	ABF57950	<i>T. aestivum</i>	93% (147/158)	297	2e ⁻⁷⁹
TaAGL41	ABF57941	<i>T. aestivum</i>	84% (126/149)	255	1e ⁻⁶⁶
TaAGL42	ABF57942	<i>T. aestivum</i>	73% (114/155)	225	1e ⁻⁵⁷
OsMADS51 (<i>Os01g69850</i>)	NP_001045235	<i>O. sativa</i>	74% (111/149)	224	2e ⁻⁵⁷
Hypothetical protein (<i>Sb03g044170</i>)	XP_002456860	<i>S. bicolor</i>	70% (110/157)	219	6e ⁻⁵⁶
Hypothetical protein (LOC100272251)	NP_001140218	<i>Z.mays</i>	69% (108/155)	197	2e ⁻⁴⁹

A

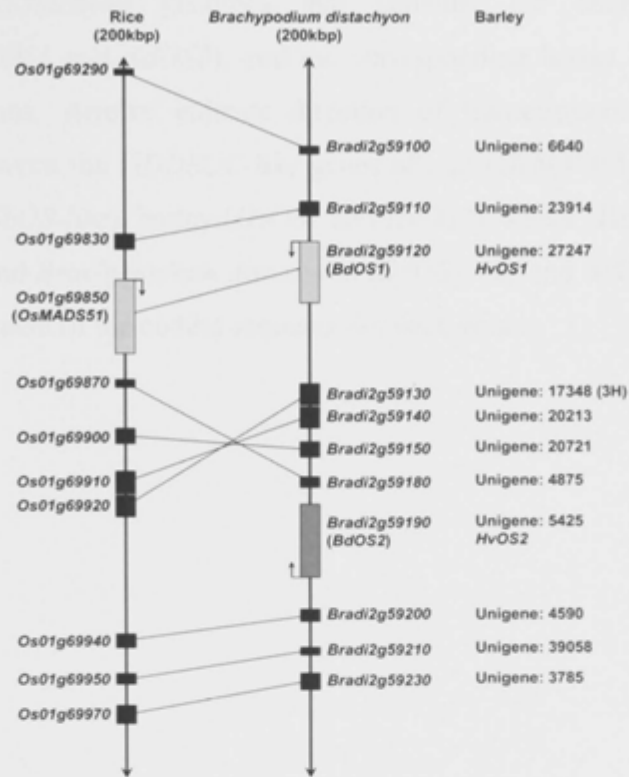

B

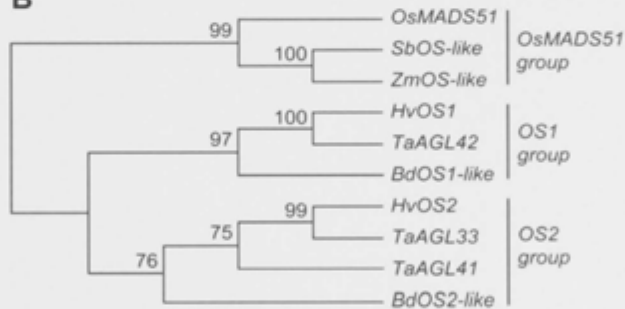

Figure 1. *HvOS1* and *HvOS2* are members of a grass specific class of MADS box genes. A, Diagrammatic representation of the syntentic region in the rice and *Brachypodium distachyon* genomes that contains the *ODDSOC-like* genes (*OsMADS51*, *BdOS1* and *BdOS2*), and the corresponding barley Unigene numbers and map locations. Arrows indicate direction of transcription. B, Phylogenetic relationships between the *ODDSOC-like* genes of rice (*OsMADS51*), maize (*ZmOS-like*), sorghum (*SbOS-like*), barley (*HvOS1* and *HvOS2*), wheat (*TaAGL33*, *TaAGL41* and *TaAGL42*) and *Brachypodium distachyon* (*BdOS1-like* and *BdOS2-like*) based on a sequence alignment of the coding sequence for each gene.

***HvOS2* is repressed by vernalization**

HvOS1 and *HvOS2* transcript levels were monitored in seedlings without and after vernalization (Fig. 2A). *HvOS1* transcript levels increased during vernalization, whereas *HvOS2* transcript levels decreased (Fig. 2A). Since down-regulation of the MADS box floral repressor *FLC* plays a central role in the vernalization response of *Arabidopsis*, the role of *HvOS2* in the vernalization response of barley was examined further. To determine if changes in *HvOS2* expression were maintained after vernalization, transcript levels were assayed in leaves two weeks after plants were removed from the cold. Expression of *HvOS2* remained low in plants that had been vernalized compared to non-vernalized controls (Fig. 2B). *HvOS2* transcript levels were also assayed in the shoot apices, showing that expression of this gene decreases in the apices of vernalized plants (Fig. 2C).

The 5' UTR of *HvOS2* is not enriched for H3K27 trimethylation

In *Arabidopsis* histone 3 lysine 27 trimethylation (H3K27me₃), a histone modification associated with long-term gene repression, mediates vernalization-induced repression of *FLC* (Bastow et al., 2004; Sung and Amasino, 2004; Finnegan and Dennis, 2007; Schmitz et al., 2008). We examined whether a similar mechanism might mediate vernalization-induced repression of *HvOS2*. H3K27me₃ levels were assayed at *HvOS2* before and after vernalization. The level of H3K27me₃ near the presumed transcriptional start site at *HvOS2* chromatin was low irrespective of vernalization treatment (Fig. 3A), suggesting that this modification does not play a role in mediating the down-regulation of *HvOS2* during vernalization. The level of H3K4me₃, a modification associated with active gene transcription, was lower in vernalized leaves than non-vernalized leaves, consistent with the reduction in *HvOS2* expression following vernalization (Fig. 3B).

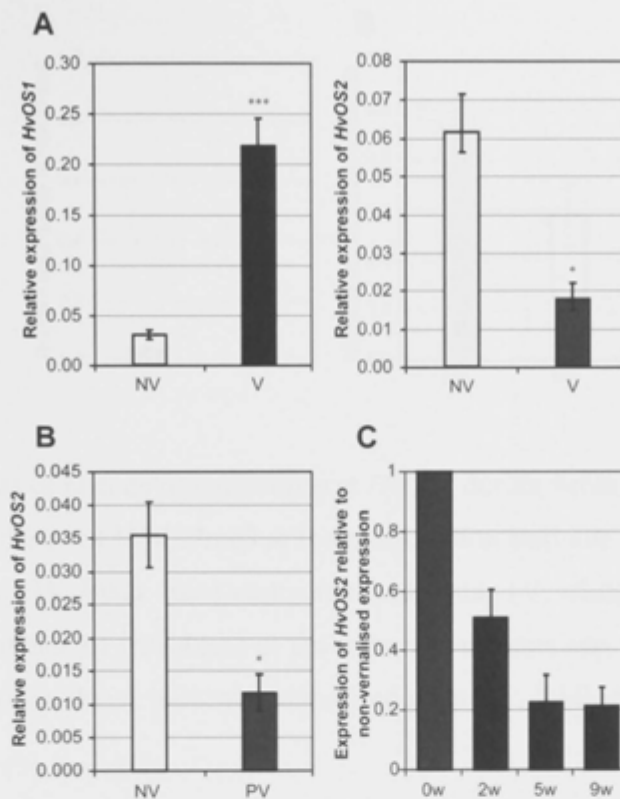

Figure 2. Vernalization-induced changes in *HvOS1* and *HvOS2* transcript levels.

A, Expression of *HvOS1* and *HvOS2* in barley (cv. Sonja) seedlings germinated in darkness at 20°C (non-vernalized = NV, white bar, n=4) versus seedlings germinated in darkness at 4°C for 49 days (vernalized = V, black bar, n=3), harvested at an equivalent stage of development. B, Expression levels of *HvOS2* in fully-expanded 1st leaves of non-vernalized plants (NV, white bar, n=3) versus vernalized plants (post-vernalization = PV, black bar, n=3), harvested in long-days at the 2 leaf stage, 10 days after the end of vernalization. C, Expression levels of *HvOS2* in shoot apices from non-vernalized plants (0) or after 2, 5 or 9 weeks vernalization (n=2). Expression levels (A-C) were assayed by qRT-PCR and are shown relative to *ACTIN*. Error bars show SE (A and B) or range. Asterisks indicate P values of ANOVA: * P < 0.05, *** P < 0.001.

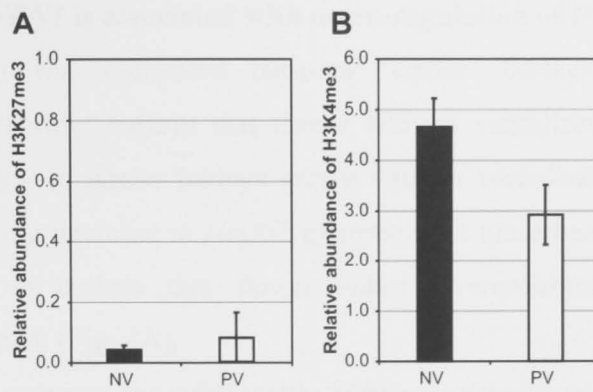

Figure 3. Analysis of histone modifications at *HvOS2* during vernalization

A, Relative abundance of H3K27me3 at the transcription start site for *HvOS2* in non-vernalized plants (NV, black bars) and vernalized plants (V, white bars) (cv. Sonja).

B, Relative abundance of H3K4me3 at the transcription start site for *HvOS2* in non-vernalized plants (NV, black bars) and vernalized plants (V, white bars) (cv. Sonja).

*This analysis was undertaken by Dr. Sandra Oliver.

Expression of *HvVRN1* is associated with down-regulation of *HvOS2*

HvOS2 expression was compared between 'winter' barleys that respond to vernalization and 'spring' barleys that flower without vernalization. Expression of *HvOS2* was strongest in winter barleys grown without vernalization treatment, and vernalization caused a decrease in *HvOS2* expression in these barleys. Expression of *HvOS2* was low in barleys that flower without vernalization, irrespective of vernalization treatment (Fig. 4A).

To further examine the relationship between vernalization requirement and *HvOS2* expression, *HvOS2* transcript levels were assayed in lines from the Sloop × Halcyon doubled haploid barley population (Read et al., 2003), grown without vernalization. This population segregates for different alleles of *HvVRN1*; a wild-type allele (*VRN1*) which is activated by vernalization and an allele with a deletion in the first intron that is active without vernalization and reduces the vernalization requirement (*VRN1-1*) (Trevaskis et al., 2006, Hemming et al., 2008). Expression of *HvOS2* was lower in lines carrying *VRN1-1* (Fig. 4B), suggesting that *HvVRN1* down-regulates *HvOS2*.

ODDSOC2 expression was then examined in the *MAINTAINED VEGETATIVE PHASE* mutant of the diploid einkorn wheat *Triticum monococcum*, which lacks the *VRN1* gene (Shitsukawa et al., 2007) (hereafter referred to as the $\Delta VRN1$ mutant). When seedlings were germinated in darkness, without vernalization, expression of *VRN1* was not detected in either the wild-type parent or the $\Delta VRN1$ mutant and expression of the *T. monococcum ODDSOC2* gene (*TmOS2*) did not differ (Fig. 4, C and D).

Expression of *TmOS2* and *VRN1* was then examined in seedlings at the end of a seven week vernalization treatment. Expression of *VRN1* was induced in vernalized seedlings of the wild-type parent but was not detected in the $\Delta VRN1$ mutant (Fig. 4D). Compared to non-vernalized control seedlings, expression of *TmOS2* was lower in vernalized seedlings, irrespective of *VRN1* genotype (WT, $P < 0.001$ and $\Delta VRN1$, $P = 0.002$) (Fig. 4C). *VRN1* and *TmOS2* transcript levels were then examined in plants that were grown at normal temperatures for 1 or 3 weeks after vernalization treatment. *VRN1* expression remained high in wildtype plants, but was not detected in the $\Delta VRN1$ mutant (Fig. 4D). In wildtype plants expression of *TmOS2* remained low, but repression of *TmOS2* was not maintained in the $\Delta VRN1$ mutant (Fig. 4C).

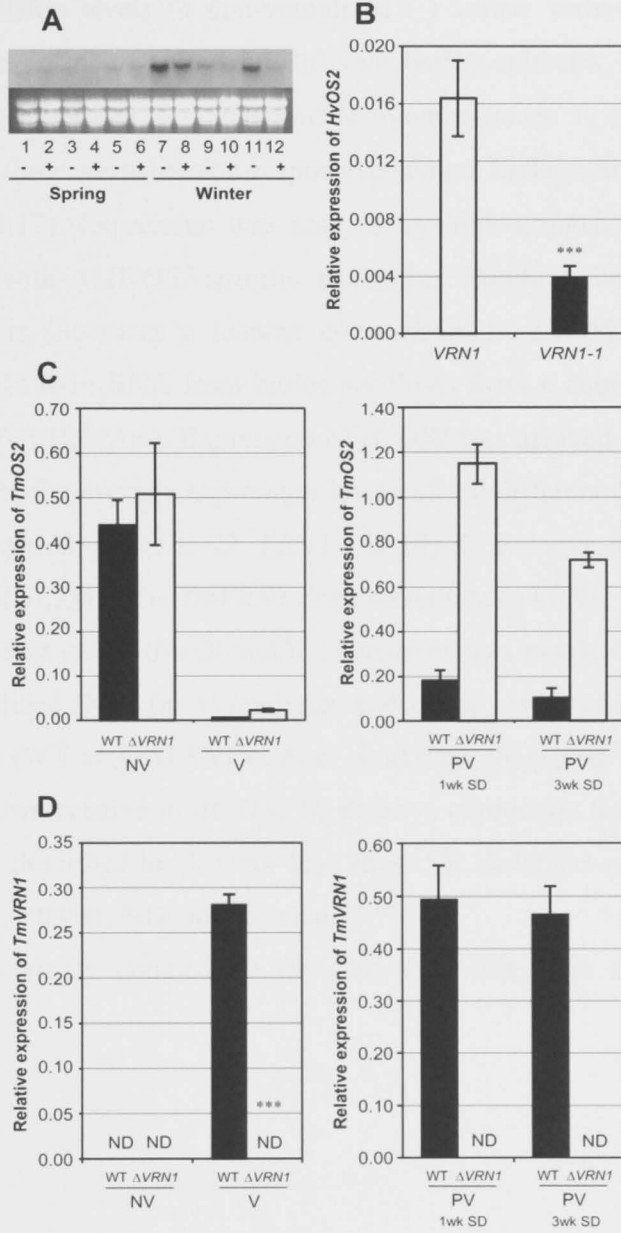

Figure 4. Expression of *ODDSOC2* in different genotypes of wheat and barley

A, *HvOS2* expression levels in non-vernalized (-) versus vernalized plants (+) (2 weeks old, grown in long days) from different barley cultivars, including 3 spring barleys that flower without vernalization: Morgenrot (lanes 1, 2), Randolph (3,4), Malta (5,6) and three vernalization-responsive winter barleys Sonja (7,8), Hudson (9,10), Mirra (11,12). Expression was assayed by high-stringency hybridization of RNA gel blots with a *HvOS2*-specific riboprobe. Ethidium bromide staining of ribosomal RNA is shown as a loading comparison. B, *HvOS2* expression levels assayed by qRT-PCR in RNA from barley seedlings from a doubled haploid barley population (Sloop × Halcyon). Expression of *HvOS2* was assayed in individual lines, relative to *ACTIN*, the average expression levels of the different *HvVRN1* genotypic classes were compared (*VRN1* n=22, *VRN1-I* n=19). C, Relative expression levels of *TmOS2-like* (*TmAGL33*) in the *TmVRN1* deletion mutant ($\Delta VRN1$) (white bars) versus the wild type parent strain (black bars). Expression was assayed in vernalized (V) (n=4), non-vernalized (NV) (n=4) seedlings and in the leaves of plants grown for 1 week or 3 weeks (WT n=3, $\Delta VRN1$ n=2) in short days (SD) post-vernalization (PV). Expression is shown relative to *ACTIN*. D, Relative expression levels of *TmVRN1* as in the conditions described in C. Error bars show SE. Asterisks indicate P values of ANOVA: ***, P, <0.001, ND, not detected.

*Figure 4A was kindly donated by Dr. Ben Trevaskis, who also undertook the experiment.

Constitutive over-expression of *HvOS2* delays flowering and inhibits leaf and stem elongation

To further investigate the function of *HvOS2*, a spring barley that flowers without vernalization and has low levels of *HvOS2* expression (cv. Golden Promise, see methods and materials) was transformed with a transgene construct that placed *HvOS2* under the control of the maize (*Zea mays*) *UBIQUITIN* promoter. Approximately 50 independent transgenic lines were generated with this construct. The majority were late flowering, compared to non-transformed plants, supporting the hypothesis that *HvOS2* is a repressor of flowering. Two independent transgenic lines, the progeny of which showed segregation for the transgene construct, were characterised in detail; *OxHvOS2-11* and *OxHvOS2-20*. In both these lines expression of *HvOS2* was higher in plants that inherited the transgene (Supplemental Fig. 3) and a late flowering phenotype segregated with the transgene in both transgenic families (Fig. 5A). Plants from the *OxHvOS2-11* line that inherited the transgene flowered on average 14 days later than siblings lacking the transgene (null siblings), which flowered at a similar time to wild type Golden Promise plants. Similarly, *OxHvOS2-20* transgenic plants flowered on average 18 days later than null siblings (Fig. 5A). Comparison of apex morphology at the third leaf stage, the developmental stage when inflorescence initiation typically occurs in Golden Promise plants under these growth conditions, showed that constitutive over-expression of *HvOS2* delays the transition to reproductive development (Fig. 5B).

In addition to influencing flowering time, constitutive over-expression of *HvOS2* inhibited leaf elongation. The length of the first and third leaf was reduced in plants constitutively over-expressing *HvOS2* (Fig. 5C). This reduction in length was due to decreased cell length; the average length of bulliform cells was significantly reduced in the first and second leaves in the transgenic plants (Fig. 5D and E). The final length of the primary spike was also reduced in transgenic plants constitutively over-expressing *HvOS2*, as were primary tiller (stem) internode lengths (Fig. 5F).

The effects of reducing *HvOS2* expression levels was also investigated using gene-specific RNA interference (RNAi) constructs. One of the lines analyzed (*hpHvOS2-2*) showed a reduction in expression levels for *HvOS2* (Supplemental Fig. 4A). There were no observable phenotypic abnormalities or any change in heading date/final leaf number in any of the RNAi lines analyzed (Supplemental Fig. 3, B and C).

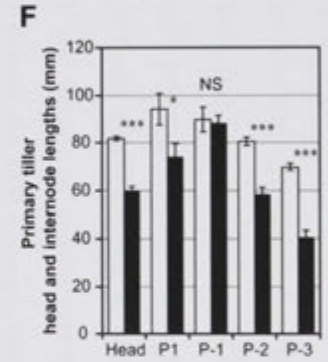
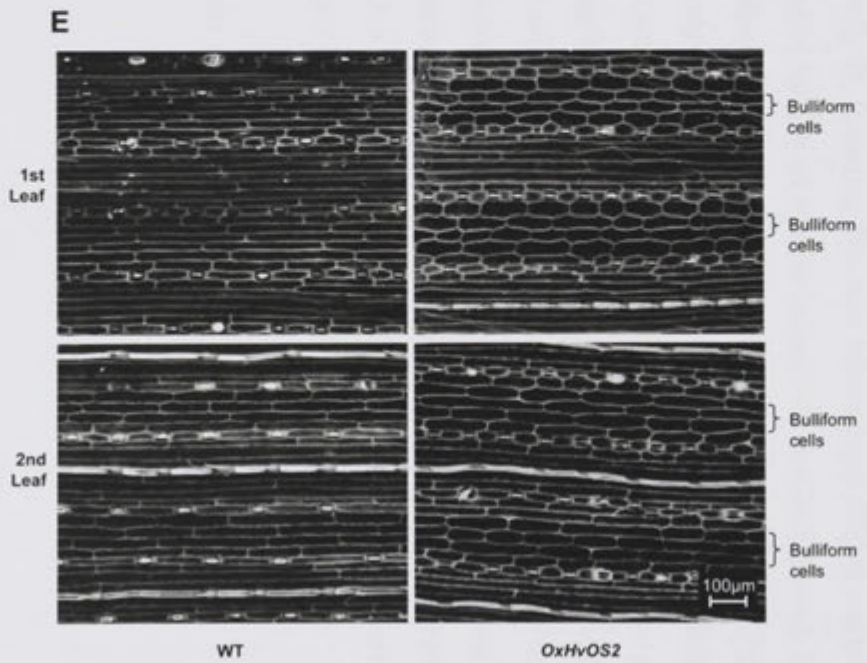
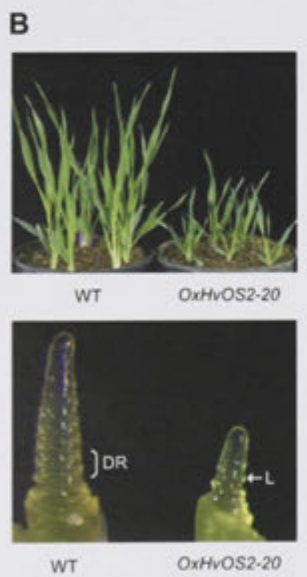
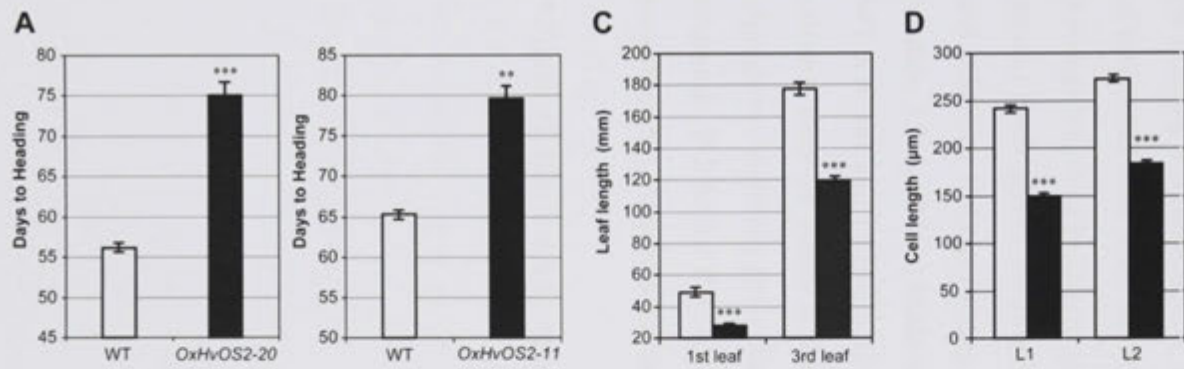

Figure 5. Phenotypes of transgenic plants that constitutively over-express *HvOS2*.

A, Average days to head emergence (heading date) of transgenic barley lines constitutively over-expressing *HvOS2* (black), versus sibling null segregant controls (plants from same transgenic line that did not inherit the transgene) (WT, white). B, Transgenic barley plants constitutively over-expressing *HvOS2* versus null segregants at the 4th leaf stage (left) and apex images from the same stage (right). DR indicates 'double ridges' the first sign of floral development. L indicates leaf primordia. C, Average length of the 1st and 3rd leaves of plants constitutively over-expressing *HvOxO2* (*OxHvOS2-20*) (black) versus the null controls (white) at the 6th leaf stage, (WT, n=5), 5 (*OxHvOS2-20*, n=5). D, Scanning Electron Microscopy (SEM) images of epidermal cells from the adaxial surface of mature leaves (1st and 2nd leaves). E, Average length of bulliform cells on the adaxial surface of mature leaves (1st and 2nd leaves) from plants constitutively over-expressing *HvOxO2* (*OxHvOS2-20*) (black) and wild-type siblings (white). Cell lengths were measured from SEM images taken at position 33% and 66% blade lengths. L1: WT n = 367 and *OxHvOS2-20*, n = 467, L2: WT n = 344 and *OxHvOS2-20* n=478. F, Average head and internode lengths of the primary tiller of plants constitutively over-expressing *HvOxO2* (black) versus null segregants (white) (P1-peduncular internode, P-1 internode: below peduncle internode, P-2 below P-1, and P-3 below P-2) n= 15 (WT), 15 (*OxHvOS2-20*). Error bars show SE. Asterisks indicate P values of ANOVA: ** P < 0.01, *** P < 0.001.

* Figure 4E Electron micrographs were taken by Dr. Mark Talbot.

Constitutive over-expression of *HvOS2* down-regulates barley homologues of *Floral Promoting Factor 1*

Microarray analysis of gene expression was used to investigate the molecular basis for the phenotype of plants constitutively over-expressing *HvOS2*. RNA from whole seedlings that constitutively over-express *HvOS2* was hybridised to the Affymetrix 22k Barley1 chip (Close et al., 2004) and compared to RNA from null sibling control lines. A total of 90 genes were differentially expressed between plants that constitutively over-express *HvOS2* and sibling null controls (2 fold change in expression, $P < 0.05$ Supplemental Table 3). Of the 94 genes differentially expressed, 65 (69%) were up-regulated in plants that constitutively over-express *HvOS2* and 25 (27%) were down-regulated. Table 2 shows the top five up and down-regulated genes that were differently regulated between plants that constitutively over-express *HvOS2*.

To verify the results of microarray analysis, the expression levels of several differentially expressed genes were quantified by quantitative RT-PCR (qRT-PCR) (Supplemental Fig. 3). Consistent with the results of microarray analysis, barley orthologs of *Flowering Promoting Factor 1* (*FPF1*), designated *HvFPF1-like1* (Contig HU14G14r) and *HvFPF1-like2* (Contig 18182), were down-regulated in plants constitutively over-expressing *HvOS2* (Supplemental Fig. 3, B and C). Conversely, expression levels of two *RNase S-Like* genes, *Hvrsh1* (Gausling, 2000, Contig 5185) and *Hvrsh2* (Contig 5058/9), were elevated in plants constitutively over-expressing *HvOS2* (Supplemental Fig. 3, D and E).

***FPF1-like* genes are regulated by vernalization and daylength in barley**

We examined whether expression of *FPF1-like* genes is influenced by vernalization in barley; a response predicted for genes regulated by *HvOS2*. Expression of *HvFPF1-like1* and *HvFPF1-like2* was higher in leaves of vernalized plants compared to non-vernalized plants, when plants were grown in long days post-vernalization (Fig. 6). Vernalization did not influence expression of *FPF1-like* genes when vernalized plants were grown in short days, where expression of *FPF1-like* genes was lower (Fig. 6). These data suggest that, in barley, down-regulation of *HvOS2* by vernalization allows increased expression of *FPF1-like* genes when plants are exposed to long-days.

Table 2. Top 5 up-regulated and down-regulated genes in *HvOS2* constitutive over-expression line

Probe Set	Best match	Fold Change	P-Value
Up-regulated			
Contig5058_x_at	<i>RNase S-like (T. aestivum)</i>	37.6	5.3e ⁻⁰⁹
Contig5059_s_at	<i>RNase S-like (T. aestivum)</i>	36.8	3.9e ⁻⁰⁹
Contig5185_at	<i>rsh1, RNase S-like (H. vulgare)</i>	16.2	1.1e ⁻⁰⁷
Contig12031_at	<i>HvODDSOC2 (H. vulgare)</i>	15.4	7.8e ⁻¹⁰
Contig1568_x_at	THION9 - Plant thionin family protein (<i>O. sativa</i>)	8.2	5.5e ⁻⁰⁴
Down-regulated			
Contig3810_at	<i>Galactinol synthase (T. aestivum)</i>	-2.9	1.6e ⁻⁰⁵
HVSMEEm0003G16r2_at	<i>cytochrome P450 (O. sativa)</i>	-3.4	5.7e ⁻⁰³
HVSMEb0010F06r2_at	No description	-3.6	3.1e ⁻⁰⁶
Contig18182_at	<i>FLOWERING PROMOTING FACTOR1 -like (A. thaliana)</i>	-3.7	3.8e ⁻⁰⁶
HU14G14r_s_at	<i>FLOWERING PROMOTING FACTOR1 -like (A. thaliana)</i>	-6.0	5.2e ⁻⁰⁵

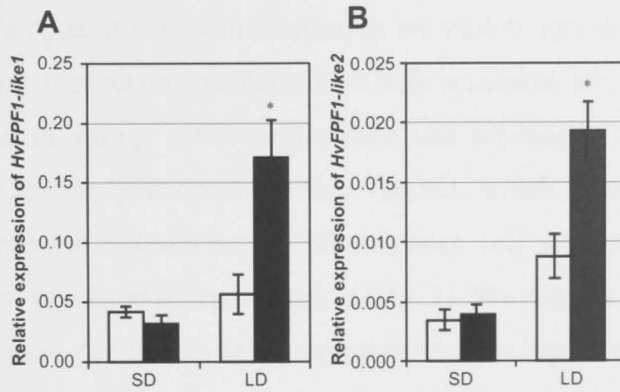

Figure 6. Influence of vernalization on the expression of *FPF1-like* genes in short or long days.

Expression of *HvFPF1-like1* (HU14G14r) (A) and *HvFPF1-like2* (Contig18182) (B) in the fully expanded 2nd leaf (harvested at the 3rd leaf stage), non-vernalized (white) versus vernalized plants (black), grown in long days (LD) or short days (SD). Expression was assayed by qRT-PCR and is shown relative to *ACTIN*. Error bars show SE. Asterisks indicate P values of ANOVA test: * P < 0.05 (min. of 3 biological repeats).

Discussion

Reproductive development and stem elongation are closely coordinated in temperate cereals. In varieties that require vernalization both processes are delayed until after winter, and begin in spring when temperature and daylength increase. We have identified a MADS box gene from barley, *HvOS2*, which potentially delays the transition to reproductive development and impedes cell elongation in stems and leaves, but is down-regulated by vernalization (Fig. 2). We suggest that *HvOS2* acts in a pathway that delays the transition to reproductive development and inhibits stem elongation prior to winter.

A single *ODDSOC* gene is found in rice; *OsMADS51* (Kim et al., 2007). *OsMADS51* promotes flowering and appears to be a component of the molecular pathway that promotes flowering in response to short-days (Kim et al. 2007). It is possible that *HvOS1* and the equivalent wheat gene (*TaAGL42*), which are induced by vernalization (Fig. 2A) (Winfield et al., 2009), also act as floral promoters. Equally, it is possible that these genes have acquired novel functions after the divergence of rice and the temperate cereals. *HvOS2*, which acts a floral repressor, might have evolved from a duplication of *OsMADS51/ODDSOC1* during the evolution of the vernalization-response pathway in temperate cereals.

HvOS2 is quantitatively down-regulated by cold (longer cold treatments cause stronger down-regulation) and repression of *HvOS2* is maintained in the shoot apex and leaves after vernalization (Fig. 2B, Supplemental Fig. 5). This pattern of gene expression is similar to *FLC* in Arabidopsis, but unlike *FLC*, repression of *HvOS2* does not appear to involve the deposition of H3K27Me3 (Fig. 3A). Vernalization-induced repression of *TmOS2* does not require *VRN1* (Fig. 4C), but *VRN1* is required to maintain repression of *TmOS2* after vernalization (Figure 4C). *HvVRN1* also down-regulates *HvOS2* in barleys that flower without vernalization (Fig. 4B). Similarly, *VRN1* down-regulates *TmOS2* when *T. monococcum* plants (lacking *VRN2*) are grown in long days (Supplemental Fig. 6). Thus, we suggest that *ODDSOC2* is down-regulated by cold independently of *VRN1*, but *VRN1* represses *ODDSOC2* during development at normal growth temperatures, both following vernalization and in barleys that flower without vernalization. Consistent with this hypothesis, microarray analysis shows that *HvOS2* is repressed by cold treatments that are not long enough to induce *HvVRN1*, but repression is not maintained when plants are returned to normal

growth temperatures (Supplemental Fig. 7) (Plexdb, Acc No. BB81, Wise et al., 2008).

Spring barleys that flower without vernalization express *HvOS2* at low levels compared to vernalization-responsive winter barleys (Fig. 4, A and B). Increasing *HvOS2* expression levels in transgenic spring barley (cv. Golden Promise) delayed flowering, suggesting that *HvOS2* functions as a repressor of flowering. The delay of flowering was caused by a delay of the transition to reproductive development, as evidenced by the impact of the *HvOS2* over-expression on final leaf number (Supplemental Fig. 8). Increasing *HvOS2* expression levels also influenced plant growth by inhibiting elongation of cells in the leaves and stems, but did not slow the rate of growth (Supplemental Fig. 8A-B). The phenotypes observed in *HvOS2* over-expression lines are different to those seen when other MADS box genes are constitutively over-expressed in barley (see Trevaskis et al. 2007b), suggesting that these phenotypes are indicative of the actual function of *HvOS2* and not simply an artefact of over-expressing a MADS box gene. Further reduction of the already low levels of *HvOS2* expression in Golden Promise by RNA interference did not influence flowering time, however. *HvOS2* activity might be below a functional threshold in this spring barley, which flowers without vernalization. Equally, the level of reduction in *HvOS2* expression by RNAi might not completely eliminate *HvOS2* activity. Isolation of *HvOS2* loss of function mutants could be used to further examine the role of this gene in future studies. Ideally this will be done in a vernalization-responsive cultivar to allow the functional importance of *HvOS2* to be assessed relative to other genes that delay flowering, such as *HvVRN2*.

The reduction of cell elongation and delay of flowering seen in *HvOS2* over-expression lines was associated with reduced expression of *FPF1*-like genes (Table 2 and Supplemental Fig. 3, B and C). *FPF1* promotes cell elongation and accelerates flowering when constitutively over-expressed in Arabidopsis (Kania et al., 1997; Melzer et al., 1999). These phenotypes mimic the effects of gibberellin (GA) application in Arabidopsis and it has been suggested that *FPF1* acts in a GA-dependent elongation pathway (Kania et al., 1997). Similar phenotypes have also been reported when *FPF1*-like genes were ectopically expressed in rice and tobacco (Ge et al., 2004; Smykal et al., 2004), suggesting that the role of *FPF1*-like genes is conserved across divergent plant lineages. The reduction of cell elongation and delayed flowering seen in *HvOS2* over-expression lines might be due to reduced

expression of *FPF1-like* genes. Many of the dwarfing phenotypes in transgenic plants constitutively over-expressing *HvOS2* were abolished upon application of GA (Supplemental Fig. 9). This is consistent with the hypothesis that *HvOS2* regulates *HvFPF1-like* genes, which may in turn alter GA responses.

In *Arabidopsis* expression of *FPF1* increases rapidly at the shoot apex in response to long days (Kania et al., 1997). This long-day response is dependant on *FT* and *CO* (Schmid et al., 2003; Wise et al., 2008) suggesting that *FPF1* acts downstream of *FT* in the long-day flowering-response pathway. The *FPF1-like* genes of barley are also daylength responsive, with elevated expression in long days (Fig. 6), suggesting that this is a conserved feature of *FPF1-like* genes. Expression of *FPF1-like* genes is also determined by vernalization status in barley; the expression of these genes increases in vernalized plants where *HvOS2* expression is reduced. The combined effects of vernalization and long-daylength on *FPF1* gene expression is consistent with a model where down-regulation of *HvOS2* in vernalized plants de-represses *FPF1-like* genes, which are then further induced through a conserved *CO-FT* regulatory pathway as daylength increases during spring (Fig. 7).

Microarray analysis identified other potential targets of *HvOS2*. For example, two *RNase S-like* genes were up-regulated in plants constitutively over-expressing *HvOS2* (Table 2). These RNases belong to a class that has only been identified in grasses, and predicted to lack RNase activity due to amino acid substitutions at critical residues in the active site (Gausling, 2000). One of these RNases, *rsh1*, is expressed in leaves and is regulated by light and developmental cues (Gausling, 2000). Expression of both RNase genes decreases during cold treatment, when *HvOS2* is down-regulated (Supplemental Fig. 7) (Plexdb, Acc No. BB81, Wise et al., 2008). This supports the hypothesis that these genes are up-regulated by *HvOS2*. The function(s) of these RNases is not known (Gausling, 2000), so it is unclear whether these genes play a role in vernalized-induced flowering or other biological processes. Analysis of microarray comparisons of gene expression during barley development show that *HvOS2*, the *RNase S-like* and *FPF1-like* genes are all expressed during post-vegetative development (Supplemental Fig. 10, Druka et al., 2006), suggesting broad roles for these genes during plant development in addition to potential roles in regulating flowering time.

In summary, we have identified a novel mechanism by which elongation and flowering are suppressed prior to vernalization in cereals. These findings further

highlight the difference between the vernalization pathways of *Arabidopsis* and cereals, reinforcing the concept that the vernalization response has evolved independently in monocot and dicot plants.



Figure 3. The vernalization model of the *Arabidopsis* pathway involves two parallel signaling routes. Flowering is triggered when...

Low-temperature (LT) via vernalization (V) leads to... (text is very faint and partially illegible)

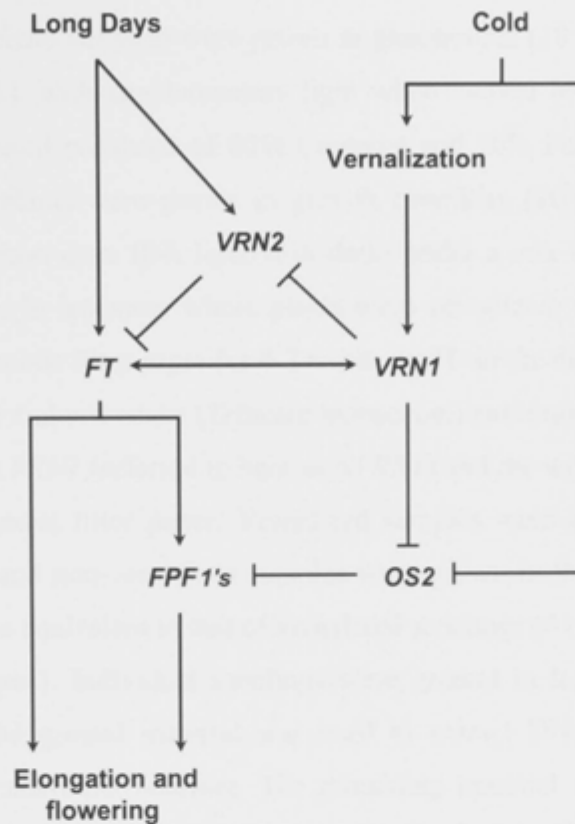

Figure 7. An extended model of the molecular genetic network that controls vernalization-induced flowering in temperate cereals.

Low-temperatures (cold) can transiently down-regulate *OS2*. Prolonged cold (vernalization) causes stable activation of *VRN1*. After vernalization, *VRN1* down-regulates *OS2*, directly or indirectly. Consequently, *FPF1-like* genes are de-repressed. *VRN1* also down-regulates *VRN2* and allows activation of *FTI* by long days (see Trevaskis et al 2007a, Distelfeld et al. 2009). Expression of *FPF1-like* genes is induced as *FTI* activity increases, and this promotes the transition to reproductive development at the shoot apex and cell elongation in the stem.

Materials and Methods:

Plant Growth

Barley plants (*Hordeum vulgare*) were grown in glasshouses (18 ± 2 °C) in long days (16-h light/8-h dark), with supplementary light when natural levels dropped below 200 μ E. The soil used consisted of 80% Compost and 20% Perlite. For controlled growth conditions plants were grown in growth chambers (20°C) with long (16-h light/8-h dark) or short days (8-h light/16-h dark) under a mix of incandescent and fluorescent lighting. In instances where plants were vernalized, seeds were imbibed and germinated on moist filter paper for 4-7 weeks at 4°C in the dark.

Seeds of the einkorn wheat (*Triticum monococcum*) *maintained vegetative phase* mutant which lacks *VRNI* (referred to here as $\Delta VRNI$) and the wild-type parent strain were imbibed on moist filter paper. Vernalized samples were grown at 4°C for 7 weeks in the dark and non-vernalized samples were grown in the dark at 22°C to a developmental stage equivalent to that of vernalized seedlings (4 cm coleoptile length, vegetative shoot apex). Individual seedlings were ground in liquid nitrogen and a small sample of the ground material was used to extract DNA to determine the genotype of each individual seedling. The remaining material was used to extract RNA for gene expression studies. Genotyping of individual seedlings was carried out using two sets of primers that annealed to the *TmVRNI* gene (Supplemental Table 4) in a PCR reaction using *Taq* DNA polymerase (New England BioLabs). PCR products were run on a 1.2% Agarose gel and the absence of a visible band was considered an indication of a seedling that was homozygous for the $\Delta VRNI$ mutation.

Apex dissection and flowering time measurements.

Apices were isolated under a binocular dissecting microscope and then digitally photographed on a Leica M8 digital camera. Leaves were numbered sequentially and plants were grown until the flag leaf emerged to determine Final Leaf Number (FLN). Heading date was measured as the day when the head first emerged from the sheath on the main shoot ($Z = 13,21$, Zadoks et al., 1974).

Gene Expression Analysis

Total RNA was extracted using the method of Chang et al. (1993) or the Qiagen RNeasy Plant Miniprep kit (Qiagen). RNA gel blots were performed as described previously (Trevaskis et al., 2003). cDNA was prepared for qRT-PCR by using an

oligo(T) primer (T18[G/C/A]) to prime first-strand complementary DNA (cDNA) synthesis from 1-5 µg of total RNA with SuperScript III reverse transcriptase enzyme (Invitrogen). qRT-PCR was performed on a Rotor-Gene 3000 real-time cycler (Corbett Research). The primers used for *ACTIN* have been described previously (Trevaskis et al., 2006) and primers for other genes that were measured are detailed in Supplemental Table 4. The primers used to detect *OS2* transcript detects both the endogenous and the transgene transcript. qRT-PCR was performed using Platinum Taq DNA polymerase (Invitrogen). Cycling conditions were 4 minutes at 94°C, 40 cycles of 10 s at 95°C, 15 s at 60°C, and 20 s at 72°C, followed by a melting-curve program (72°C–95°C with a 5 s hold at each temperature). Fluorescence data were acquired at the 72°C step and during the melting-curve program. Expression levels of genes of interest were calculated relative to *ACTIN* using the comparative quantification analysis method (Rotogene-5; Corbett Research), which takes into account the amplification efficiency of each primer set. Data presented are averages of a minimum of three biological replicates unless stated otherwise and the error bars show SE.

Chromatin Immunoprecipitation (ChIP)

ChIP of leaf tissue was performed as described by Oliver et al. (2009) using the third leaf from non-vernalized or post-vernalized plants. Post-vernalized plants were derived from seeds that had been germinated for seven weeks under vernalizing conditions (4°C), and then transferred to normal glasshouse conditions and grown to the third leaf stage. The results shown are the mean of two biological replicate experiments. Sequences for primers used in ChIP experiments are listed in Supplemental Table 4.

Plant Transformation

Constitutive over-expression constructs were made by introducing a full-length *HvOS2* cDNA into a GATEWAY (Invitrogen) adapted cloning vector described previously (Hemming et al. 2008), which uses the maize *UBIQUITIN* promoter (Christensen et al. 1992) to drive transgene expression. RNAi constructs were made using the GATEWAY cloning system; the hairpin cassette from HELLSGATE12 (Wesley et al. 2001) was fused to the maize ubiquitin promoter and placed in the pWBVEC8 binary vector backbone (Wang et al. 1998). A map of the resulting

vector (pSTARGATE) can be found at <http://www.pi.csiro.au/RNAi/vectors.htm>. Barley plants were transformed using *Agrobacterium* transformation of excised embryos of the variety “Golden Promise” (Tingay et al., 1997; Matthews et al., 2001). Golden Promise is a spring barley that flowers without vernalization (genotype *HvVRN1-1*, Δ *HvVRN2*), and is photoperiod insensitive. T1 and T2 plants were screened for segregation of the transgene using primers that amplify the hygromycin selectable marker gene. Expression analysis was carried out on plants hemizygous or homozygous for the transgene and sibling null control lines which did not inherit the transgene.

Microarray analysis

RNA was extracted using the method of Chang et al. (1993) and then further purified using RNeasy columns (Qiagen). Probe synthesis, labelling, hybridisation to the Barley1 Gene chip (Close et al., 2004) and RNA quality was assessed at the Australian Genome Research Facilities (AGRF; Melbourne, VIC, Australia), following the manufacturer’s recommendations (Affymetrix, Santa Clara, CA). Microarray analyses were performed on 3 biological replicates of each sample. The resulting dataset was analysed in R v2.7.0 and analysed using packages from Bioconductor (Gentleman et al., 2004, <http://www.bioconductor.org/>), using default settings. Normalisation was carried out by Robust Multichip Analysis (RMA) and differentially expressed genes were identified using the LIMMA package (Linear Models for Microarray Data; (Smyth, 2005)). Genes with p-values higher than 0.01 or with a change in gene expression lower than 1.5-fold were excluded from further analysis. Microarray data has been deposited in the Plant Expression Database (www.plexdb.org), BB 93.

Microscopy and Image analysis

Leaf segments taken from positions at 33% and 66% of the total length of the leaf were fixed at room temperature in 70% ethanol for at least 2h, then dehydrated to 100% ethanol in 10% steps (30 min each step). 100% ethanol was replaced twice and the tissue was critical point dried with CO₂ and mounted on double-sided carbon tabs attached to SEM stubs, adaxial side up. Tissue was then viewed uncoated with a 4 quadrant backscattered electron detector in a Zeiss EVO LS15 SEM. Tissue was

viewed using 20 kV accelerating voltage under variable pressure mode, with 10 Pa chamber pressure. Images of the tissue were taken for analysis using the analySIS LS Professional software (v2.6). The length of bulliform cells (Wenzel et al., 1997) were measured manually with the line tool.

Sequence Database Searches

All sequence database searches (nucleotide and protein) were performed using the Basic Local Alignment Search Tool (BLAST) at the National Center for Biotechnology (NCBI) (<http://blast.ncbi.nlm.nih.gov/Blast.cgi>).

Phylogenetic Analysis

Alignments of the full nucleotide coding sequences were performed using MUSCLE v.3.6 (Edgar, 2004) and were edited using the BioEdit interface (v. 7.0.9.0) (Hall, 1999), (Supplemental Fig. 2B,C). Phylogenetic analyses were conducted in MEGA4, using the Neighbor-Joining method (default settings) (Saitou and Nei, 1987). Bootstrap values were calculated using 10000 replicates.

Statistical analysis

All statistical analysis was carried out using GenStat 11th Ed. (Payne, 2008) unless specified otherwise.

Literature Cited

- An H, Roussot C, Suarez-Lopez P, Corbesier L, Vincent C, Pineiro M, Hepworth S, Mouradov A, Justin S, Turnbull C, Coupland G (2004)** CONSTANS acts in the phloem to regulate a systemic signal that induces photoperiodic flowering of Arabidopsis. *Development* **131**: 3615-3626
- Bastow R, Mylne JS, Lister C, Lippman Z, Martienssen RA, Dean C (2004)** Vernalization requires epigenetic silencing of *FLC* by histone methylation. *Nature* **427**: 164-167
- Chang S, Puryear J, Cairney J (1993)** A simple and efficient method for isolating RNA from pine trees. *Plant Molecular Biology Reporter* **11**: 113-116
- Christensen AH, Sharrock RA, Quail PH (1992)** Maize polyubiquitin genes: structure, thermal perturbation of expression and transcript splicing, and promoter activity following transfer to protoplasts by electroporation. *Plant Molecular Biology* **18**: 675-689
- Close TJ, Wanamaker SI, Caldo RA, Turner SM, Ashlock DA, Dickerson JA, Wing RA, Muehlbauer GJ, Kleinhofs A, Wise RP (2004)** A New Resource for Cereal Genomics: 22K Barley GeneChip Comes of Age. *Plant Physiology* **134**: 960-968
- Corbesier L, Vincent C, Jang S, Fornara F, Fan Q, Searle I, Giakountis A, Farrona S, Gissot L, Turnbull C, Coupland G (2007)** FT Protein Movement Contributes to Long-Distance Signalling in Floral Induction of Arabidopsis. *Science* **316**: 1030-1033
- Danyluk J, Kane NA, Breton G, Limin AE, Fowler DB, Sarhan F (2003)** *TaVRT-1*, a putative transcription factor associated with vegetative to reproductive transition in cereals. *Plant Physiology* **132**: 1849-1860
- De Lucia F, Crevillen P, Jones AME, Greb T, Dean C (2008)** A PHD-Polycomb Repressive Complex 2 triggers the epigenetic silencing of *FLC* during vernalization. *Proceedings of the National Academy of Sciences of the United States of America* **105**: 16831-16836
- Distelfeld A, Li C, Dubcovsky J (2009)** Regulation of flowering in temperate cereals. *Current Opinion in Plant Biology* **12**: 178-184
- Druka A, Muehlbauer G, Druka I, Caldo R, Baumann U, Rostoks N, Schreiber A, Wise R, Close T, Kleinhofs A, Graner A, Schulman A, Langridge P,**

- Sato K, Hayes PM, McNicol J, Marshall D, Waugh R** (2006) An atlas of gene expression from seed to seed through barley development. *Functional Integrative Genomics* **6**: 202-211
- Edgar RC** (2004) MUSCLE: multiple sequence alignment with high accuracy and high throughput. *Nucleic Acids Research* **32**: 1792-1797
- Faure S, Higgins J, Turner A, Laurie DA** (2007) The *FLOWERING LOCUS T-Like* Gene Family in Barley (*Hordeum vulgare*). *Genetics* **176**: 599-609
- Finnegan EJ, Dennis ES** (2007) Vernalization-Induced Trimethylation of Histone H3 Lysine 27 at *FLC* Is Not Maintained in Mitotically Quiescent Cells. *Current Biology* **17**: 1978-1983
- Gausig K** (2000) A barley gene (*rsh1*) encoding a ribonuclease S-like homologue specifically expressed in young light-grown leaves. *Planta* **210**: 574-579
- Ge L, Chen H, Jiang J-F, Zhao Y, Xu M-L, Xu Y-Y, Tan K-h, Xu Z-H, Chong K** (2004) Overexpression of *OsRAA1* Causes Pleiotropic Phenotypes in Transgenic Rice Plants, including Altered Leaf, Flower, and Root Development and Root Response to Gravity. *Plant Physiology* **135**: 1502-1513
- Gentleman R, Carey V, Bates D, Bolstad B, Dettling M, Dudoit S, Ellis B, Gautier L, Ge Y, Gentry J, Hornik K, Hothorn T, Huber W, Iacus S, Irizarry R, Leisch F, Li C, Maechler M, Rossini A, Sawitzki G, Smith C, Smyth G, Tierney L, Yang J, Zhang J** (2004) Bioconductor: open software development for computational biology and bioinformatics. *Genome Biology* **5**: R80
- Greenup A, Peacock WJ, Dennis ES, Trevaskis B** (2009) The molecular biology of seasonal flowering-responses in Arabidopsis and the cereals. *Annals of Botany* **103**: 1165-1172
- Hall TA** (1999) BioEdit: a user-friendly biological sequence alignment editor and analysis program for Windows 95/98/NT. *Nucleic Acids Symposium Series* **41**: 95-98
- Hemming MN, Peacock WJ, Dennis ES, Trevaskis B** (2008) Low-temperature and daylength cues are integrated to regulate *FLOWERING LOCUS T* in barley. *Plant Physiology* **147**: 355-366
- Hepworth SR, Valverde F, Ravenscroft D, Mouradov A, Coupland G** (2002) Antagonistic regulation of flowering-time gene *SOC1* by CONSTANS and FLC via separate promoter motifs. *EMBO Journal* **21**: 4327-4337

- Imaizumi T, Kay SA** (2006) Photoperiodic control of flowering: not only by coincidence. *Trends in Plant Science* **11**: 550-558
- Jaeger KE, Graf A, Wigge PA** (2006) The control of flowering in time and space. *Journal of Experimental Botany* **57**: 3415-3418
- Jang S, Marchal V, Panigrahi KCS, Wenkel S, Soppe W, Deng XW, Valverde F, Coupland G** (2008) Arabidopsis COP1 shapes the temporal pattern of CO accumulation conferring a photoperiodic flowering response. *EMBO Journal* **27**: 1277-1288
- Kania T, Russenberger D, Peng S, Apel K, Melzer S** (1997) *FPF1* Promotes Flowering in Arabidopsis. *Plant Cell* **9**: 1327-1338
- Kardailsky I, Shukla VK, Ahn JH, Dagenais N, Christensen SK, Nguyen JT, Chory J, Harrison MJ, Weigel D** (1999) Activation Tagging of the Floral Inducer *FT*. *Science* **286**: 1962-1965
- Kim SL, Lee S, Kim HJ, Nam HG, An G** (2007) *OsMADS51* Is a Short-Day Flowering Promoter That Functions Upstream of *Ehd1*, *OsMADS14*, and *Hd3a*. *Plant Physiology* **145**: 1484-1494
- King RW, Moritz T, Evans LT, Martin J, Andersen CH, Blundell C, Kardailsky I, Chandler PM** (2006) Regulation of Flowering in the Long-Day Grass *Lolium temulentum* by Gibberellins and the *FLOWERING LOCUS T* Gene. *Plant Physiology* **141**: 498-507
- Kobayashi Y, Kaya H, Goto K, Iwabuchi M, Araki T** (1999) A Pair of Related Genes with Antagonistic Roles in Mediating Flowering Signals. *Science* **286**: 1960-1962
- Matthews PR, Wang M-B, Waterhouse PM, Thornton S, Fieg SJ, Gubler F, Jacobsen JV** (2001) Marker gene elimination from transgenic barley, using co-transformation with adjacent 'twin T-DNAs' on a standard *Agrobacterium* transformation vector. *Molecular Breeding* **7**: 195-202
- Melzer S, Kampmann G, Chandler J, Apel K** (1999). *FPF1* modulates the competence to flowering in Arabidopsis. *The Plant Journal* **18**, 395-405
- Michaels SD, Amasino RM** (1999) *FLOWERING LOCUS C* Encodes a Novel MADS Domain Protein That Acts as a Repressor of Flowering. *Plant Cell* **11**: 949-956

- Michaels SD, Himmelblau E, Kim SY, Schomburg FM, Amasino RM (2005)** Integration of Flowering Signals in Winter-Annual Arabidopsis. *Plant Physiology* **137**: 149-156
- Oliver SN, Finnegan EJ, Dennis ES, Peacock WJ, Trevaskis B (2009)** Vernalization-induced flowering in cereals is associated with changes in histone methylation at the *VERNALIZATION1* gene. *Proceedings of the National Academy of Sciences of the United States of America* **106**: 8386-8391
- Onouchi H, Igeno MI, Perilleux C, Graves K, Coupland G (2000)** Mutagenesis of Plants Overexpressing *CONSTANS* Demonstrates Novel Interactions among Arabidopsis Flowering-Time Genes. *Plant Cell* **12**: 885-900
- Payne RW, Harding SA, Murray DA, Soutar DM, Baird DB, Glaser AI, Channing IC, Welham SJ, Gilmour AR, Thompson R, Webster R (2008)** GenStat Release 11 Reference Manual, Part 2 Directives. VSN International, Hemel Hempstead, England
- Read BJ, Raman H, McMichael G, Chalmers KJ, Ablett GA, Platz GJ, Raman, R, Genger RK, Boyd WJR, Li CD, Grime CR, Park RF, Wallwork H, Prangnell R, Lance RCM (2003)** Mapping and QTL analysis of the barley population Sloop × Halcyon. *Australian Journal of Agricultural Research* **54**: 1145-1153
- Saitou N, Nei M (1987)**. The neighbor-joining method: a new method for reconstructing phylogenetic trees. *Molecular Biology and Evolution* **4**: 406-425
- Sasani S, Hemming, MN, Oliver, SN, Greenup, A, Tavakkol-Afshari R, Mahfoozi S, Poustini K, Sharifi H-R, Dennis ES, Peacock WJ, Trevaskis B (2009)** The influence of vernalization and daylength on expression of flowering-time genes in the shoot apex and leaves of barley (*Hordeum vulgare*). *Journal of Experimental Botany* **60**: 2169-2178
- Schmid M, Uhlenhaut NH, Godard F, Demar M, Bressan R, Weigel D, Lohmann JU (2003)** Dissection of floral induction pathways using global expression analysis. *Development* **130**: 6001-6012
- Schmitz RJ, Sung S, Amasino RM (2008)** Histone arginine methylation is required for vernalization-induced epigenetic silencing of *FLC* in winter-annual

Arabidopsis thaliana. Proceedings of the National Academy of Sciences of the United States of America **105**: 411-416

Schubert D, Primavesi L, Bishopp A, Roberts G, Doonan J, Jenuwein T, Goodrich J (2006) Silencing by plant Polycomb-group genes requires dispersed trimethylation of histone H3 at lysine 27. EMBO Journal **25**: 4638-4649

Sheldon CC, Rouse DT, Finnegan EJ, Peacock WJ, Dennis ES (2000) The molecular basis of vernalization: The central role of *FLOWERING LOCUS C* (FLC). Proceedings of the National Academy of Sciences of the United States of America **97**: 3753-3758

Sheldon CC, Burn JE, Perez PP, Metzger J, Edwards JA, Peacock WJ, Dennis ES (1999) The *FLF* MADS Box Gene: A Repressor of Flowering in *Arabidopsis* Regulated by Vernalization and Methylation. Plant Cell **11**: 445-458

Shitsukawa N, Ikari C, Shimada S, Kitagawa S, SakaMoto K, Saito H, Ryuto H, Fukunishi N, Abe T, Takumi S, Nasuda S, Murai K (2007) The einkorn wheat (*Triticum monococcum*) mutant, maintained vegetative phase, is caused by a deletion in the *VRN1* gene. Genes and Genetic Systems **82**: 167-170

Smykal P, Gleissner R, Corbesier L, Apel K, Melzer S (2004) Modulation of flowering responses in different *Nicotiana* varieties. Plant Molecular Biology. **55**: 253-262

Smyth G (2005) LIMMA: Linear Models for Microarray Data. In Bioinformatics and Computational Biology Solutions Using R and Bioconductor, pp. 397-420

Sung S, Amasino RM (2004). Vernalization in *Arabidopsis thaliana* is mediated by the PHD finger protein VIN3. Nature **427**: 159-164

Takahashi R, Yasuda S (1971) Genetics of earliness and growth habit in barley. In Barley Genetics II (Proceedings of the Second International Barley Genetics Symposium), R.A. Nilan, ed (Washington State University Press), pp. 388-408

Tingay S, McElroy D, Kalla R, Fieg S, Wang M, Thornton S, Brettell R (1997) *Agrobacterium tumefaciens*-mediated barley transformation. The Plant Journal **11**: 1369-1376

Trevaskis B, Bagnall DJ, Ellis MH, Peacock WJ, Dennis ES (2003) MADS box genes control vernalization-induced flowering in cereals. Proceedings of the

National Academy of Sciences of the United States of America **100**: 13099-13104

Trevaskis B, Hemming MN, Peacock WJ, Dennis ES (2006) *HvVRN2* Responds to Daylength, whereas *HvVRN1* Is Regulated by Vernalization and Developmental Status. *Plant Physiology* **140**: 1397-1405

Trevaskis B, Hemming MN, Dennis ES, Peacock WJ (2007a) The molecular basis of vernalisation-induced flowering in cereals. *Trends in Plant Science* **12**: 352-357

Trevaskis B, Tadege M, Hemming MN, Peacock WJ, Dennis ES, Sheldon C (2007b) *Short Vegetative Phase-like* MADS-box genes inhibit floral meristem identity in barley. *Plant Physiology* **143**: 225-235

Turck F, Fornara F, Coupland G (2008) Regulation and Identity of Florigen: *FLOWERING LOCUS T* Moves Center Stage. *Annual Review of Plant Biology* **59**: 573-594

Turner A, Beales J, Faure S, Dunford RP, Laurie DA (2005) The Pseudo-Response Regulator *Ppd-H1* Provides Adaptation to Photoperiod in Barley. *Science* **310**: 1031-1034

Valverde F, Mouradov A, Soppe W, Ravenscroft D, Samach A, Coupland G (2004) Photoreceptor Regulation of CONSTANS Protein in Photoperiodic Flowering. *Science* **303**: 1003-1006

von Zitzewitz J, Szucs P, Dubcovsky J, Yan LL, Francia E, Pecchioni N, Casas A, Chen THH, Hayes PM, Skinner JS (2005) Molecular and structural characterization of barley vernalization genes. *Plant Molecular Biology* **59**: 449-467

Wang MB, Li Z, Mathews PR, Upadyaya NM, Waterhouse PM (1998) Improved vectors for *Agrobacterium tumefaciens*-mediated transformation of monocot plants. *Acta Hortae* **461**: 401-407

Wenzel CL, Chandler PM, Cunningham RB, Passioura JB (1997) Characterization of the Leaf Epidermis of Barley (*Hordeum vulgare* L. 'Himalaya'). *Annals of Botany* **79**: 41-46

Wesley SV, Helliwell CA, Smith NA, Wang MB, Rouse DT, Liu Q, Gooding PS, Singh SP, Abbott D, Stoutjesdijk PA, Robinson SP, Gleave AP, Green AG,

- Peter M. Waterhouse PM** (2001) Construct design for efficient, effective and high-throughput gene silencing in plants. *Plant Journal* **27**: 581–590
- Winfield M, Lu C, Wilson I, Coghill J, Edwards K** (2009). Cold and light-induced changes in the transcriptome of wheat leading to phase transition from vegetative to reproductive growth. *BMC Plant Biology* **9**: 55
- Wise RP, Caldo RA, Hong L, Shen L, Cannon E, Dickerson JA** (2008) BarleyBase/PLEXdb. In *Plant Bioinformatics*, D. Edwards, ed (Humana Press), pp. 347-363
- Wood CC, Robertson M, Tanner G, Peacock WJ, Dennis ES, Helliwell CA** (2006) The *Arabidopsis thaliana* vernalization response requires a polycomb-like protein complex that also includes VERNALIZATION INSENSITIVE 3. *Proceedings of the National Academy of Sciences of the United States of America* **103**: 14631-14636
- Yan L, Loukoianov A, Tranquilli G, Helguera M, Fahima T, Dubcovsky J** (2003) Positional cloning of the wheat vernalization gene *VRN1*. *Proceedings of the National Academy of Sciences of the United States of America* **100**: 6263-6268
- Yan L, Loukoianov A, Blechl A, Tranquilli G, Ramakrishna W, SanMiguel P, Bennetzen JL, Echenique V, Dubcovsky J** (2004) The Wheat *VRN2* Gene Is a Flowering Repressor Down-Regulated by Vernalization. *Science* **303**: 1640-1644
- Yan L, Fu D, Li C, Blechl A, Tranquilli G, Bonafede M, Sanchez A, Valarik M, Yasuda S, Dubcovsky J** (2006) The wheat and barley vernalization gene *VRN3* is an orthologue of *FT*. *Proceedings of the National Academy of Sciences of the United States of America* **103**: 19581-19586
- Zadoks JC, Chang TT, Konzak CF** (1974) A decimal code for the growth stages of cereals. *Weed Research* **14**: 415-421
- Zeevaart JAD** (2006). Florigen Coming of Age after 70 Years. *Plant Cell* **18**: 1783-1789.

Supplemental Data

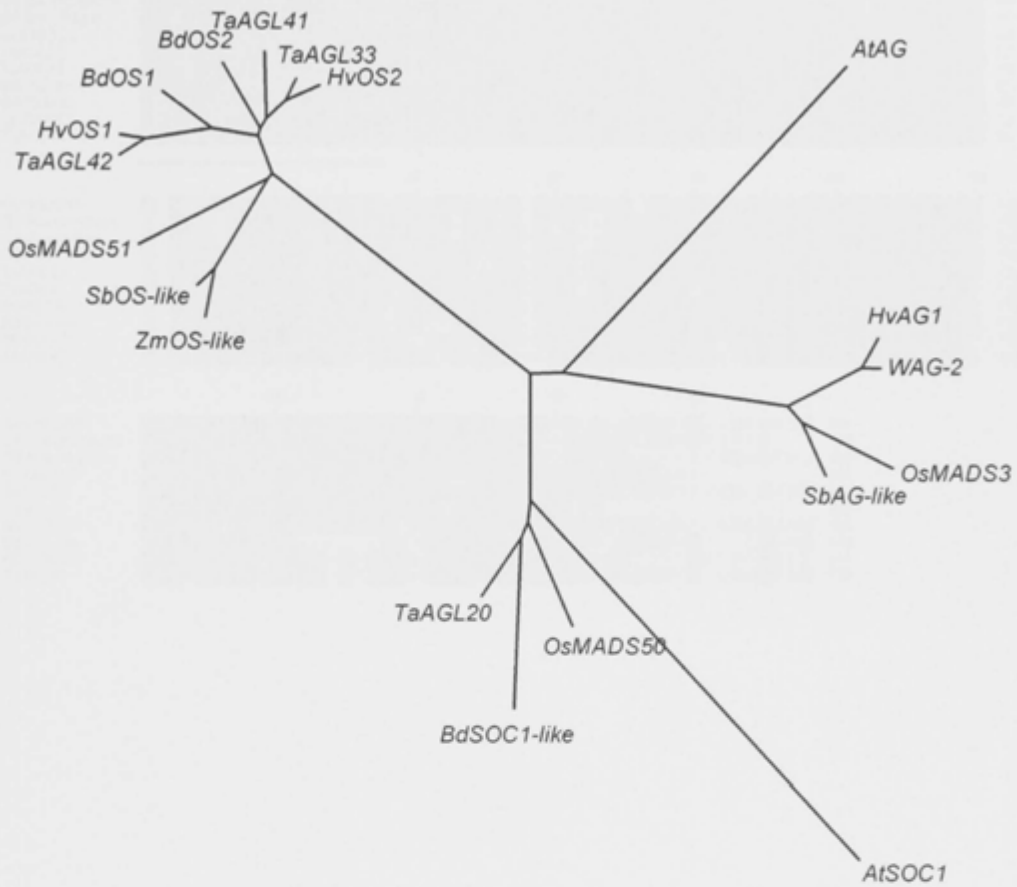

Supplemental Figure S1. Phylogenetic relationships between *ODDSOC-like* genes and other plant MADS box genes. The sequence alignment used to create this tree is provided in Supplemental Fig. S2C.

A

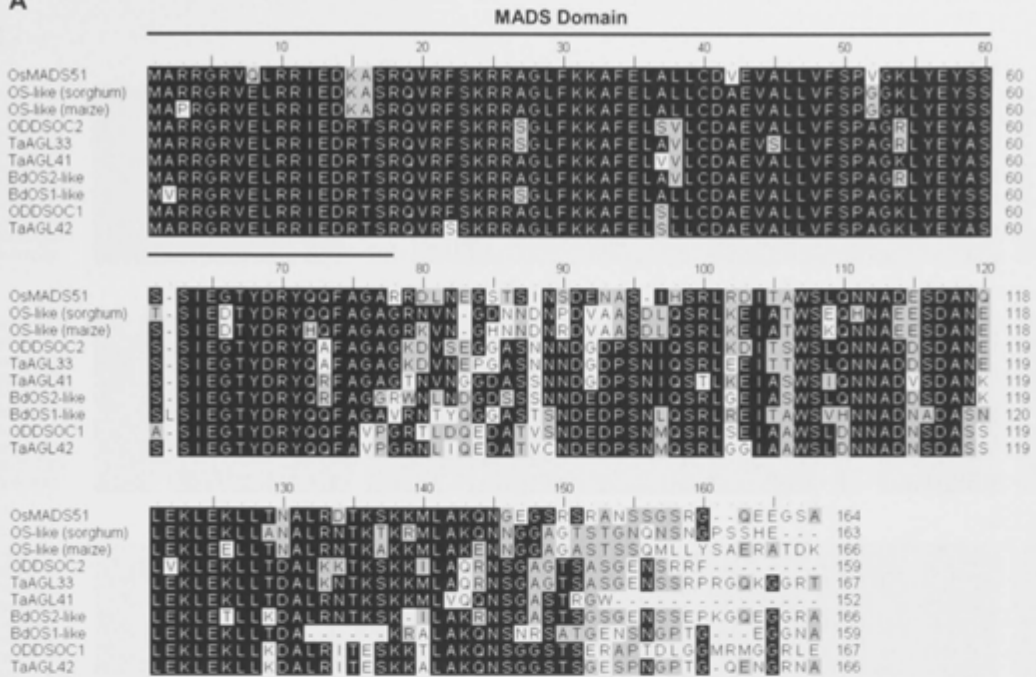

C

	10	20	30	40	50	60	
AtAG	ATGGCGT	GAGGAAAGAT	TCGAAATG	AAACGGATCGAG	ACACACCGAAT	TCGTCAAGTCACT	60
HvAG1	ATGGCGG	AGGGGCGGGAT	TCGAGATC	GAAGCGCATCGAG	ACACCACCAAC	CGGCAGGTCAAC	60
WAG-2	ATGGCGG	AGGGGCGGGAT	TCGAGATC	GAAGCGCATCGAG	ACACCACCAAC	CGGCAGGTCAAC	60
OsMADS3	ATGGCGG	AGGGGCGGGAT	TCGAGATC	GAAGCGCATCGAG	ACACCACCAAC	CGGCAGGTCAAC	60
SbAG-like	ATGGCGG	AGGGGCGGGAT	TCGAGATC	GAAGCGCATCGAG	ACACCACCAAC	CGGCAGGTCAAC	60
OsMADS51	ATGGCGG	AGGGGCGGGAT	TCGAGATC	GAAGCGCATCGAG	ACACCACCAAC	CGGCAGGTCAAC	60
SbOS-like	ATGGCGG	AGGGGCGGGAT	TCGAGATC	GAAGCGCATCGAG	ACACCACCAAC	CGGCAGGTCAAC	60
ZmOS-like	ATGGCGG	AGGGGCGGGAT	TCGAGATC	GAAGCGCATCGAG	ACACCACCAAC	CGGCAGGTCAAC	60
BtOS2	ATGGCGG	AGGGGCGGGAT	TCGAGATC	GAAGCGCATCGAG	ACACCACCAAC	CGGCAGGTCAAC	60
TaAGL41	ATGGCGG	AGGGGCGGGAT	TCGAGATC	GAAGCGCATCGAG	ACACCACCAAC	CGGCAGGTCAAC	60
HvOS2	ATGGCGG	AGGGGCGGGAT	TCGAGATC	GAAGCGCATCGAG	ACACCACCAAC	CGGCAGGTCAAC	60
TaAGL33	ATGGCGG	AGGGGCGGGAT	TCGAGATC	GAAGCGCATCGAG	ACACCACCAAC	CGGCAGGTCAAC	60
BtOS1	ATGGCGG	AGGGGCGGGAT	TCGAGATC	GAAGCGCATCGAG	ACACCACCAAC	CGGCAGGTCAAC	60
HvOS1	ATGGCGG	AGGGGCGGGAT	TCGAGATC	GAAGCGCATCGAG	ACACCACCAAC	CGGCAGGTCAAC	60
TaAGL42	ATGGCGG	AGGGGCGGGAT	TCGAGATC	GAAGCGCATCGAG	ACACCACCAAC	CGGCAGGTCAAC	60
AtSOC1	ATGGCGG	AGGGGCGGGAT	TCGAGATC	GAAGCGCATCGAG	ACACCACCAAC	CGGCAGGTCAAC	60
BtSOC1-like	ATGGCGG	AGGGGCGGGAT	TCGAGATC	GAAGCGCATCGAG	ACACCACCAAC	CGGCAGGTCAAC	60
OsMADS50	ATGGCGG	AGGGGCGGGAT	TCGAGATC	GAAGCGCATCGAG	ACACCACCAAC	CGGCAGGTCAAC	60
TaAGL20	ATGGCGG	AGGGGCGGGAT	TCGAGATC	GAAGCGCATCGAG	ACACCACCAAC	CGGCAGGTCAAC	60

	70	80	90	100	110	120	
AtAG	TTTCTG	CAAGCGTAG	AAATGGT	TGCTCAAGAAAG	GTACGAGCTCT	GTGTCTTG	120
HvAG1	TTCTGCA	AGGCGCCG	AACGGCTC	TGCAAGAAGGG	GTACGAGCTCT	GTGTCTTG	120
WAG-2	TTCTGCA	AGGCGCCG	AACGGCTC	TGCAAGAAGGG	GTACGAGCTCT	GTGTCTTG	120
OsMADS3	TTCTGCA	AGGCGCCG	AACGGCTC	TGCAAGAAGGG	GTACGAGCTCT	GTGTCTTG	120
SbAG-like	TTCTGCA	AGGCGCCG	AACGGCTC	TGCAAGAAGGG	GTACGAGCTCT	GTGTCTTG	120
OsMADS51	TTCTGCA	AGGCGCCG	AACGGCTC	TGCAAGAAGGG	GTACGAGCTCT	GTGTCTTG	120
SbOS-like	TTCTGCA	AGGCGCCG	AACGGCTC	TGCAAGAAGGG	GTACGAGCTCT	GTGTCTTG	120
ZmOS-like	TTCTGCA	AGGCGCCG	AACGGCTC	TGCAAGAAGGG	GTACGAGCTCT	GTGTCTTG	120
BtOS2	TTCTGCA	AGGCGCCG	AACGGCTC	TGCAAGAAGGG	GTACGAGCTCT	GTGTCTTG	120
TaAGL41	TTCTGCA	AGGCGCCG	AACGGCTC	TGCAAGAAGGG	GTACGAGCTCT	GTGTCTTG	120
HvOS2	TTCTGCA	AGGCGCCG	AACGGCTC	TGCAAGAAGGG	GTACGAGCTCT	GTGTCTTG	120
TaAGL33	TTCTGCA	AGGCGCCG	AACGGCTC	TGCAAGAAGGG	GTACGAGCTCT	GTGTCTTG	120
BtOS1	TTCTGCA	AGGCGCCG	AACGGCTC	TGCAAGAAGGG	GTACGAGCTCT	GTGTCTTG	120
HvOS1	TTCTGCA	AGGCGCCG	AACGGCTC	TGCAAGAAGGG	GTACGAGCTCT	GTGTCTTG	120
TaAGL42	TTCTGCA	AGGCGCCG	AACGGCTC	TGCAAGAAGGG	GTACGAGCTCT	GTGTCTTG	120
AtSOC1	TTCTGCA	AGGCGCCG	AACGGCTC	TGCAAGAAGGG	GTACGAGCTCT	GTGTCTTG	120
BtSOC1-like	TTCTGCA	AGGCGCCG	AACGGCTC	TGCAAGAAGGG	GTACGAGCTCT	GTGTCTTG	120
OsMADS50	TTCTGCA	AGGCGCCG	AACGGCTC	TGCAAGAAGGG	GTACGAGCTCT	GTGTCTTG	120
TaAGL20	TTCTGCA	AGGCGCCG	AACGGCTC	TGCAAGAAGGG	GTACGAGCTCT	GTGTCTTG	120

	130	140	150	160	170	180	
AtAG	GCTGAAGT	CGCGCTCA	TCGTTCTCT	TAGCGTGGT	CGTCTATGAGT	ACTAAAGAAC	180
HvAG1	GCCGAGGT	TCCGCTCA	TCGTTCTCT	TAGCGTGGT	CGTCTATGAGT	ACTAAAGAAC	180
WAG-2	GCCGAGGT	TCCGCTCA	TCGTTCTCT	TAGCGTGGT	CGTCTATGAGT	ACTAAAGAAC	180
OsMADS3	GCCGAGGT	TCCGCTCA	TCGTTCTCT	TAGCGTGGT	CGTCTATGAGT	ACTAAAGAAC	180
SbAG-like	GCCGAGGT	TCCGCTCA	TCGTTCTCT	TAGCGTGGT	CGTCTATGAGT	ACTAAAGAAC	180
OsMADS51	GCCGAGGT	TCCGCTCA	TCGTTCTCT	TAGCGTGGT	CGTCTATGAGT	ACTAAAGAAC	180
SbOS-like	GCCGAGGT	TCCGCTCA	TCGTTCTCT	TAGCGTGGT	CGTCTATGAGT	ACTAAAGAAC	180
ZmOS-like	GCCGAGGT	TCCGCTCA	TCGTTCTCT	TAGCGTGGT	CGTCTATGAGT	ACTAAAGAAC	180
BtOS2	GCCGAGGT	TCCGCTCA	TCGTTCTCT	TAGCGTGGT	CGTCTATGAGT	ACTAAAGAAC	180
TaAGL41	GCCGAGGT	TCCGCTCA	TCGTTCTCT	TAGCGTGGT	CGTCTATGAGT	ACTAAAGAAC	180
HvOS2	GCCGAGGT	TCCGCTCA	TCGTTCTCT	TAGCGTGGT	CGTCTATGAGT	ACTAAAGAAC	180
TaAGL33	GCCGAGGT	TCCGCTCA	TCGTTCTCT	TAGCGTGGT	CGTCTATGAGT	ACTAAAGAAC	180
BtOS1	GCCGAGGT	TCCGCTCA	TCGTTCTCT	TAGCGTGGT	CGTCTATGAGT	ACTAAAGAAC	180
HvOS1	GCCGAGGT	TCCGCTCA	TCGTTCTCT	TAGCGTGGT	CGTCTATGAGT	ACTAAAGAAC	180
TaAGL42	GCCGAGGT	TCCGCTCA	TCGTTCTCT	TAGCGTGGT	CGTCTATGAGT	ACTAAAGAAC	180
AtSOC1	GCTGAAGT	TCGCTCTA	TCGTTCTCT	TAGCGTGGT	CGTCTATGAGT	ACTAAAGAAC	180
BtSOC1-like	GCTGAAGT	TCGCTCTA	TCGTTCTCT	TAGCGTGGT	CGTCTATGAGT	ACTAAAGAAC	180
OsMADS50	GCCGAGGT	TCCGCTCA	TCGTTCTCT	TAGCGTGGT	CGTCTATGAGT	ACTAAAGAAC	180
TaAGL20	GCCGAGGT	TCCGCTCA	TCGTTCTCT	TAGCGTGGT	CGTCTATGAGT	ACTAAAGAAC	180

	190	200	210	220	230	240	
AtAG	AGTGTAA	AAGGACAC	CGGATCG	GTGGCAG	AATTTGCA	CAAGAAAG	240
HvAG1	AGTGTAA	AAGGACAC	CGGATCG	GTGGCAG	AATTTGCA	CAAGAAAG	240
WAG-2	AGTGTAA	AAGGACAC	CGGATCG	GTGGCAG	AATTTGCA	CAAGAAAG	240
OsMADS3	AGTGTAA	AAGGACAC	CGGATCG	GTGGCAG	AATTTGCA	CAAGAAAG	240
SbAG-like	AGTGTAA	AAGGACAC	CGGATCG	GTGGCAG	AATTTGCA	CAAGAAAG	240
OsMADS51	AGTGTAA	AAGGACAC	CGGATCG	GTGGCAG	AATTTGCA	CAAGAAAG	240
SbOS-like	AGTGTAA	AAGGACAC	CGGATCG	GTGGCAG	AATTTGCA	CAAGAAAG	240
ZmOS-like	AGTGTAA	AAGGACAC	CGGATCG	GTGGCAG	AATTTGCA	CAAGAAAG	240
BtOS2	AGTGTAA	AAGGACAC	CGGATCG	GTGGCAG	AATTTGCA	CAAGAAAG	240
TaAGL41	AGTGTAA	AAGGACAC	CGGATCG	GTGGCAG	AATTTGCA	CAAGAAAG	240
HvOS2	AGTGTAA	AAGGACAC	CGGATCG	GTGGCAG	AATTTGCA	CAAGAAAG	240
TaAGL33	AGTGTAA	AAGGACAC	CGGATCG	GTGGCAG	AATTTGCA	CAAGAAAG	240
BtOS1	AGTGTAA	AAGGACAC	CGGATCG	GTGGCAG	AATTTGCA	CAAGAAAG	240
HvOS1	AGTGTAA	AAGGACAC	CGGATCG	GTGGCAG	AATTTGCA	CAAGAAAG	240
TaAGL42	AGTGTAA	AAGGACAC	CGGATCG	GTGGCAG	AATTTGCA	CAAGAAAG	240
AtSOC1	AAATGCA	AAGGACAC	CGGATCG	GTGGCAG	AATTTGCA	CAAGAAAG	240
BtSOC1-like	AGCATG	CAAGAAAC	ATGAA	CGTATAG	ACGTATCA	AAAGAAAT	240
OsMADS50	AGTATGC	CAAGAAAC	ATGAA	CGTATAG	ACGTATCA	AAAGAAAT	240
TaAGL20	AGCATG	CAAGAAAC	ATGAA	CGTATAG	ACGTATCA	AAAGAAAT	240

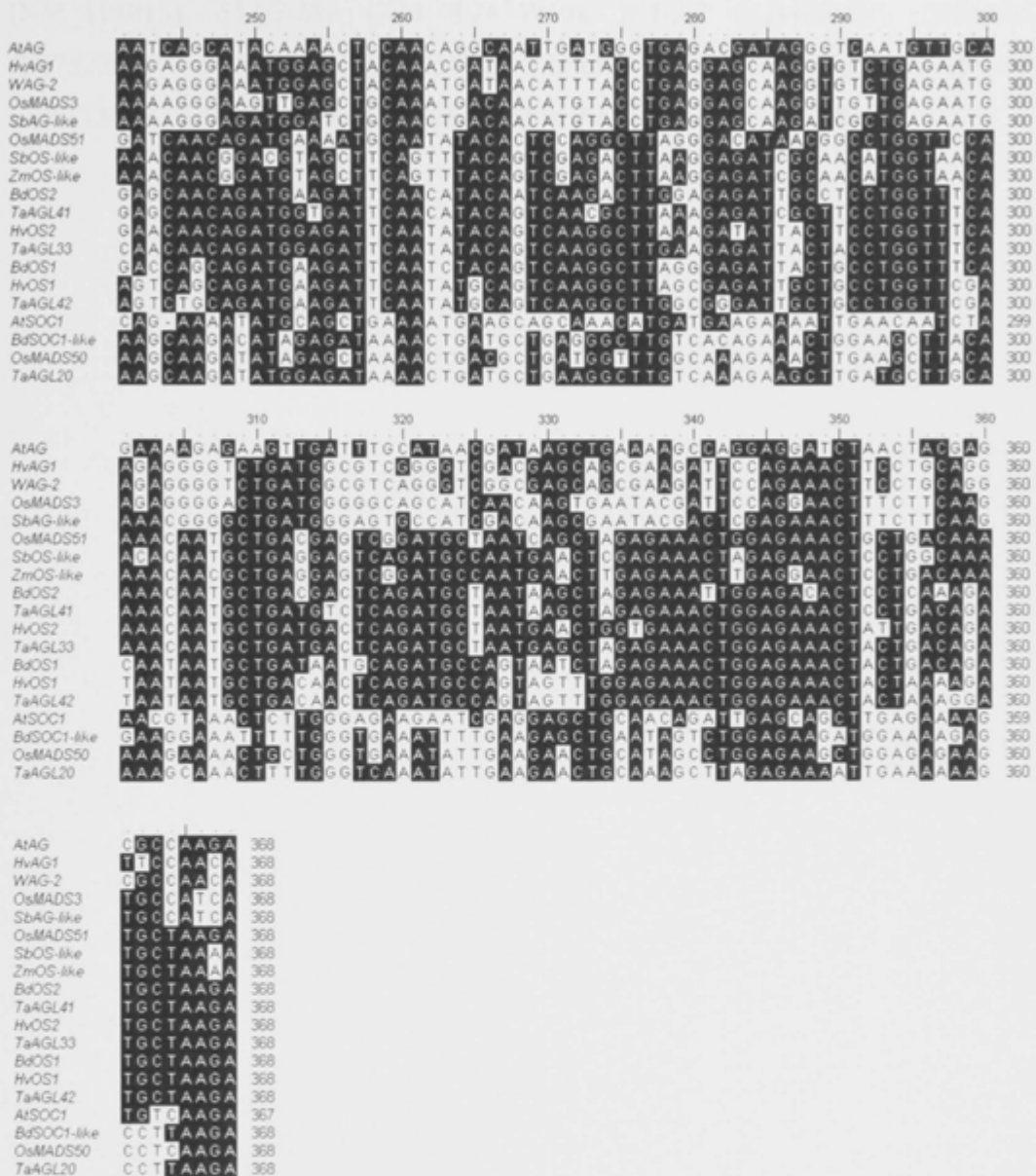

Supplemental Figure S2. Alignments of cDNA and predicted protein sequences. A, Alignment of the predicted protein sequences of *ODDSOC-like* genes B, Alignment of cDNA sequences used in constructing phylogeny of *ODDSOC-like* MADS box genes (Fig 1B). C, Alignment of nucleotide sequences used in constructing phylogeny of *ODDSOC-like* MADS box genes with *AGAMOUS-like* genes and *SOC-1-like* genes as out groups (Supplemental Fig. S1). *OsMADS51* (NM_001051770), *SbOS-like* (XM_002456815), *ZmOS-like* (NP_001140218), *BdOS2-like* (Bradi2g59190), *TaAGL41* (DQ512357), *ODDSOC2* (Unigene 5425), *TaAGL33* (DQ512366), *BdOS1-like* (Bradi2g59120), *ODDSOC1* (Unigene 27247), *TaAGL42* (DQ512358), *AtAG*

(NM_118013), *SbAG-like* (XM_002454940), *WAG-2* (AB465688), *OsMADS3* (L37528.1), *HvAG-1* (AF486648), *AtSOC1* (NM_130128), *OsMADS50* (AY332476.1), *BdSOC1-like* (Bradi1g77020), *TaAGL20* (DQ512338).

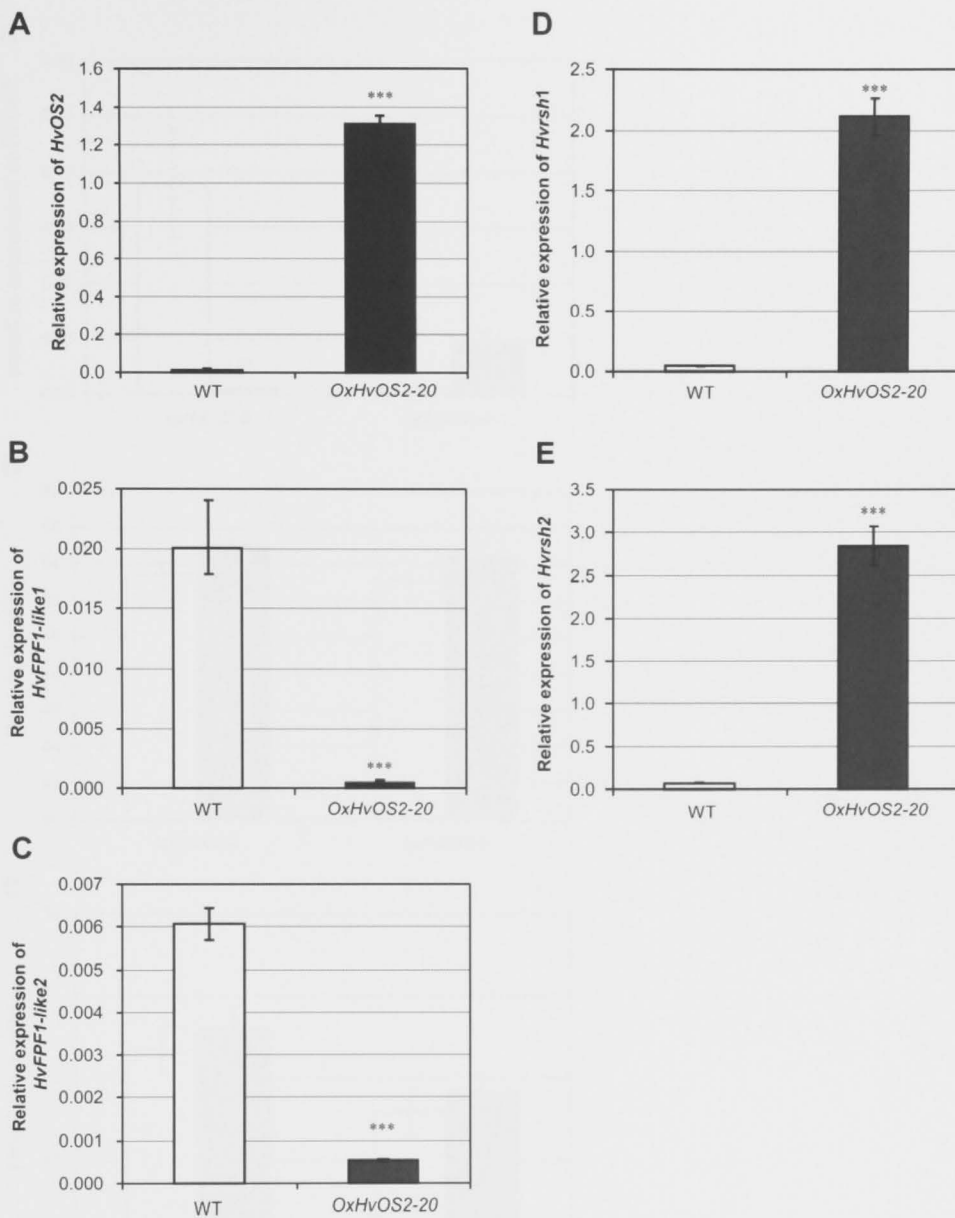

Supplemental Figure S3. Quantitative RT-PCR analysis of gene expression in *HvOS2* over-expression lines. Expression levels of candidate genes were assayed by qRT-PCR, in transgenic barley seedlings over expressing *HvOS2* (black) and compared to wildtype null (WT) siblings (white) at the 2nd leaf stage. Error bars show SE. Asterisks indicate P values of ANOVA: ***, P, < 0.001. (min. of 3 biological repeats). A, *HvOS2* (Contig12031). B, *HvPF1-like1* (HU14G14r) C, *HvPF1-like2* (Contig18182) D, *Hvrsh1* (Contig5185). E, *Hvrsh2* (Contig5058/9).

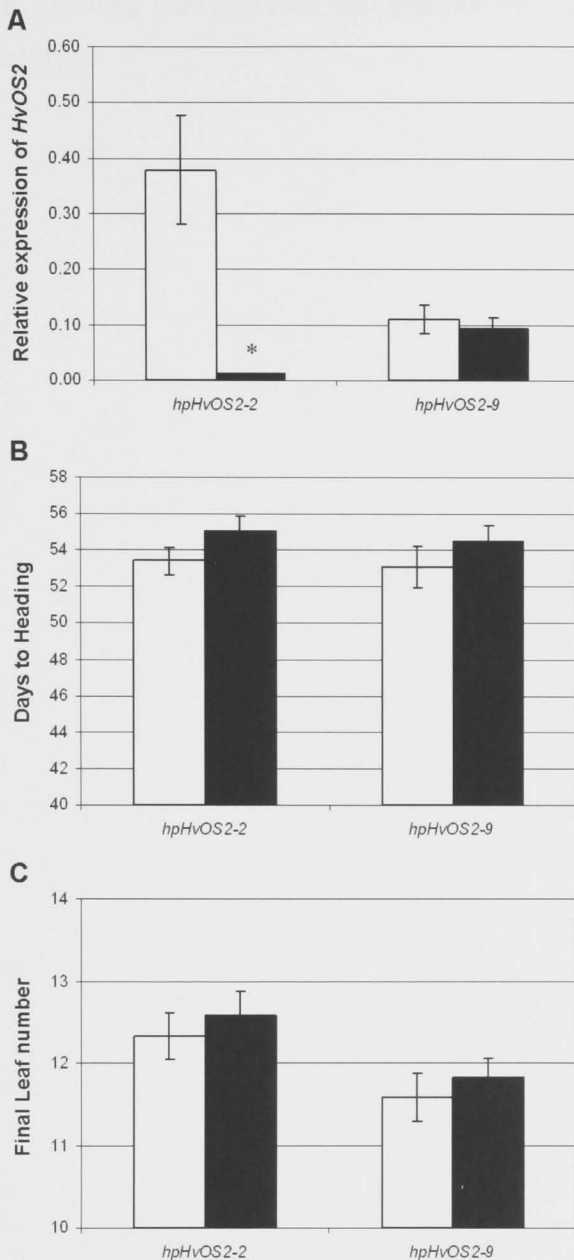

Supplemental Figure S4. Phenotypes and expression levels of *HvOS2* in RNAi transgenic plants. A, Expression of *HvOS2* in RNAi transgenic plants. Data is shown for two transgenic barley two independent lines transformed with gene-specific RNA interference (RNAi) constructs (black) versus wild-type null siblings (white). Expression was assayed by qRT-PCR and is shown relative to *ACTIN*. Error bars show SE. Asterisks indicate P values of ANOVA test: *, $P < 0.05$ (min. of 3 biological repeats). B, The average number of days until heading and C, final leaf number for transgenic plants (black) and wild-type siblings (white) Error bars show

SE. Heading date and final leaf number was calculated from 15 individual plants per genotype.

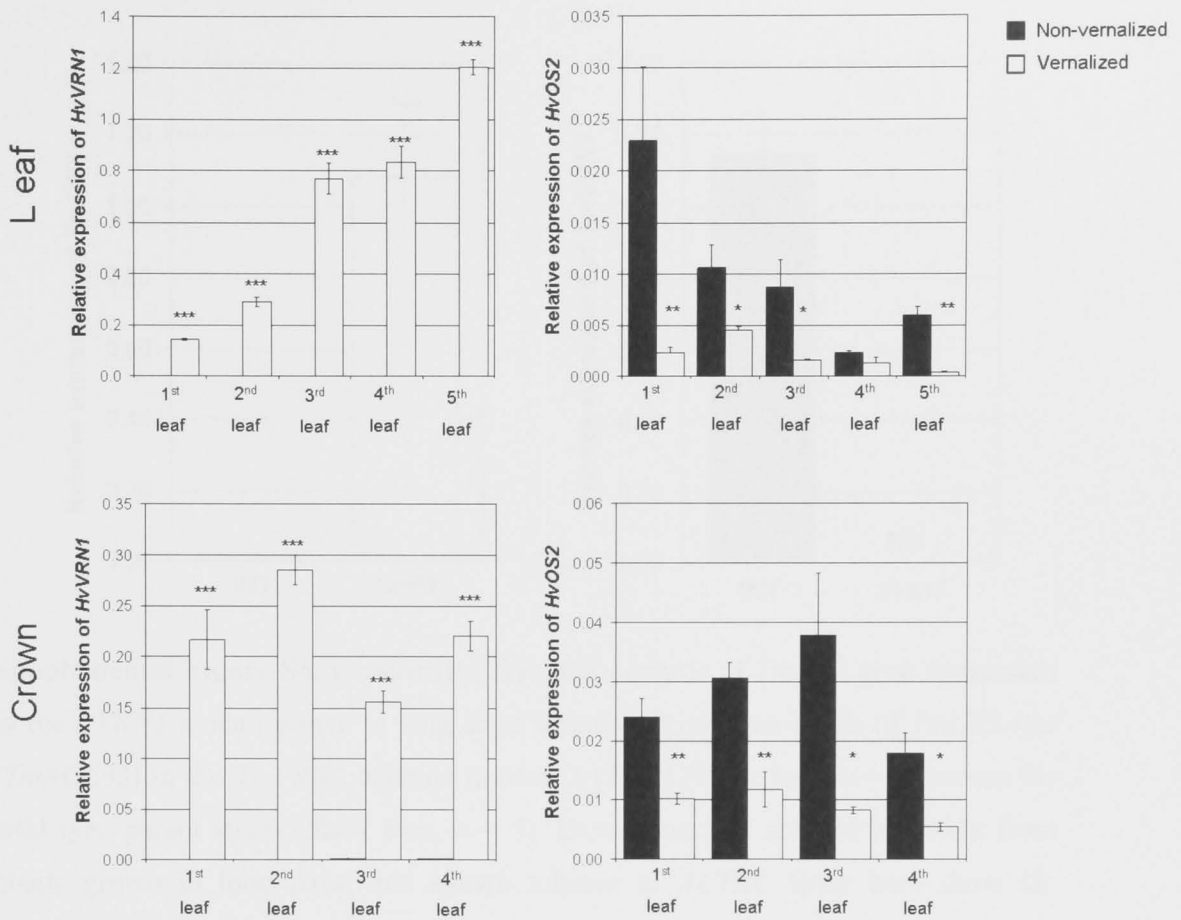

Supplemental Figure S5. Quantitative RT-PCR analysis of *HvOS2* gene expression during development in leaf and crown tissue. Relative expression levels of *HvVRN1* and *HvOS2* (white bars) in leaves and crown tissue from barley plants (cv. Sonja). The fully expanded leaf and crown tissue was taken from non-vernalized plants (black bars) and plants vernalized for 49 days (white bars) at the 1st, 2nd, 3rd, 4th and 5th leaf stage. Expression was assayed in non-vernalized (black bars) and plants vernalized for 49 days (white bars), and is shown relative to *ACTIN*. Error bars show SE from a minimum of 4 biological repeats. Asterisks indicate P values of ANOVA: *, P, <0.05; **, P, <0.01; ***, P, <0.001.

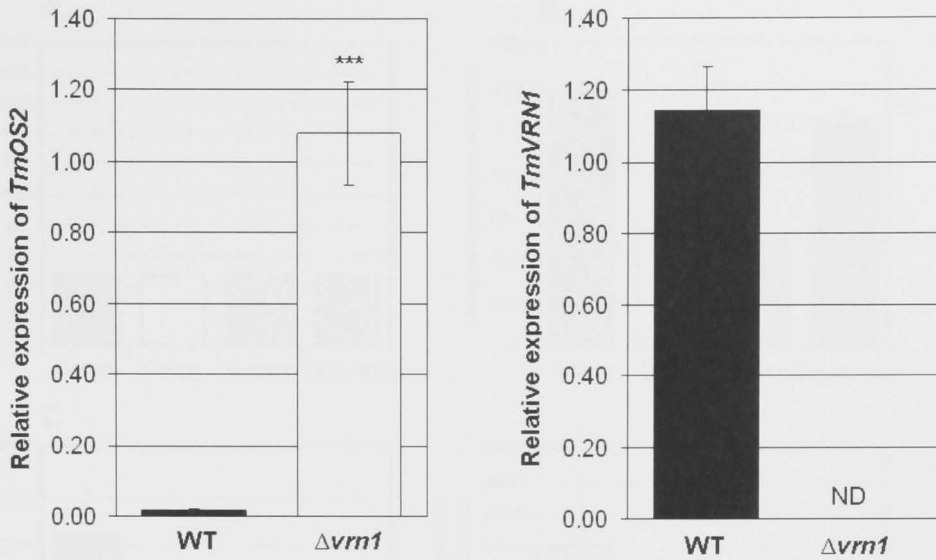

Supplemental Figure S6. Quantitative RT-PCR analysis of *TmOS2* gene expression in the $\Delta VRN1$ mutant grown in long days. Relative expression levels of *TmOS2*-like (*TmAGL33*) in the *TmVRN1* deletion mutant ($\Delta VRN1$) (white bars, $n = 4$) versus the wild type parent strain (black bars, $n = 5$). Expression was assayed in leaves from plants grown in long days, and shown relative to *ACTIN*. Error bars show SE. Asterisks indicate P values of ANOVA: ***, $P, <0.001$, ND, not detected.

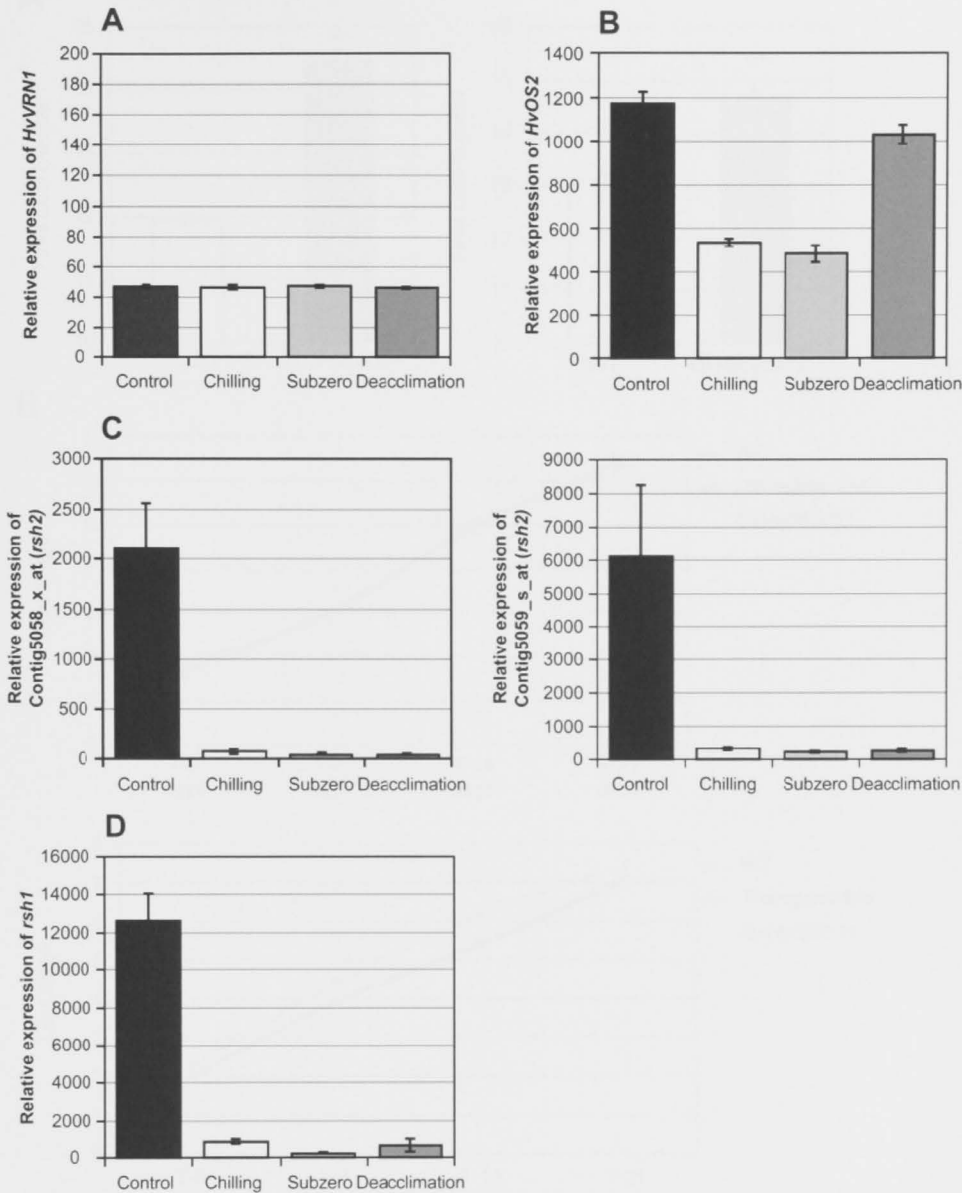

Supplemental Figure S7. Selected data from low temperature stress microarray experiment (cv. Dicktoo). Mean expression levels for A, *HvVRN1* B, *HvOS2* C, *Hvrsh2* and D, *Hvrsh1*. Error bars show standard error of 3 biological repeats. Data was sourced from the Plant Expression Database (www.plexdb.org) Experiment Accession No. BB81.

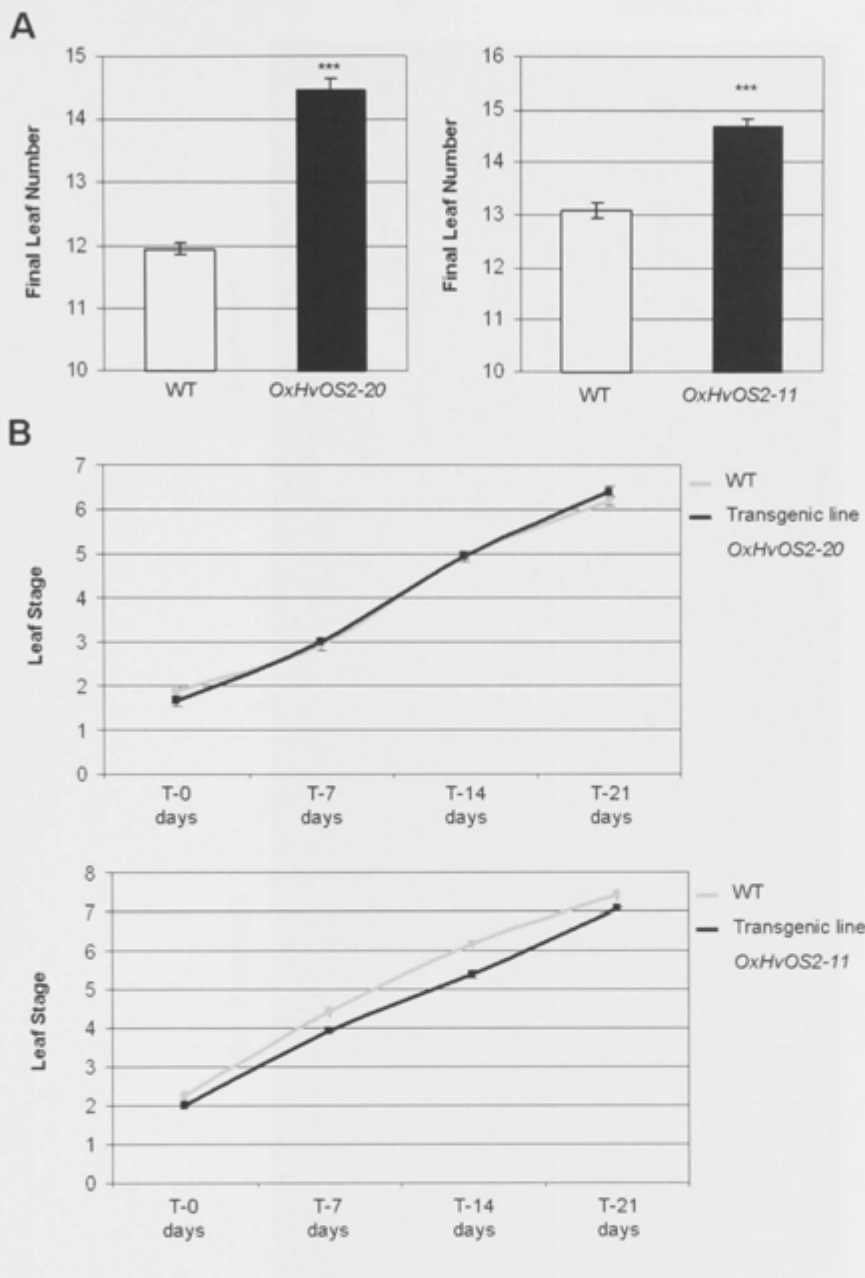

Supplemental Figure S8. Leaf appearance rate and final leaf number in *HvOS2* over-expression lines versus null sibling control lines. A, Final leaf number and B, leaf emergence rate for lines *OxHvOS2-20* and *OxHvOS2-11*. Leaf emergence rate was recorded 7, 14 and 21 days after the majority of plants reached the 2 leaf stage (T-0 days). Error bars show SE from a minimum of 12 biological repeats. Asterisks indicate P values of ANOVA: ***, $P < 0.001$.

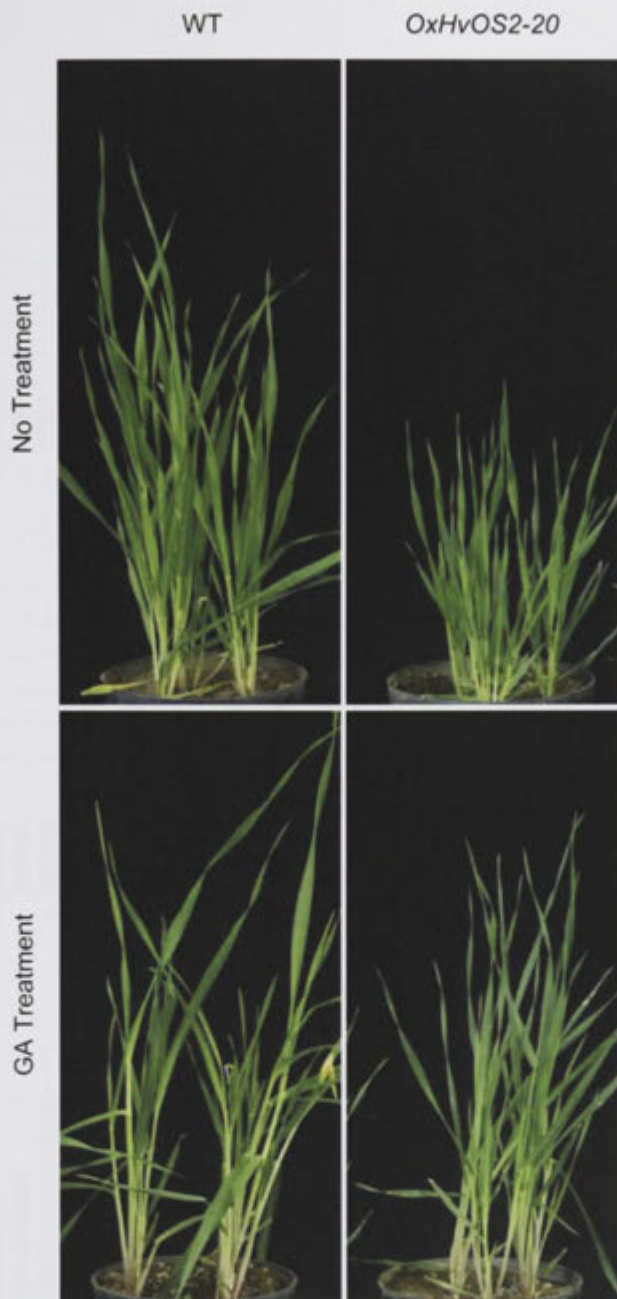

Supplemental Figure S9. Images of transgenic plants over-expressing *HvOS2* and wild-type siblings with or without GA treatment. A single application (10 μ L) of GA₃ (2.5 μ g/ μ L) in ethanol was applied to leaves.

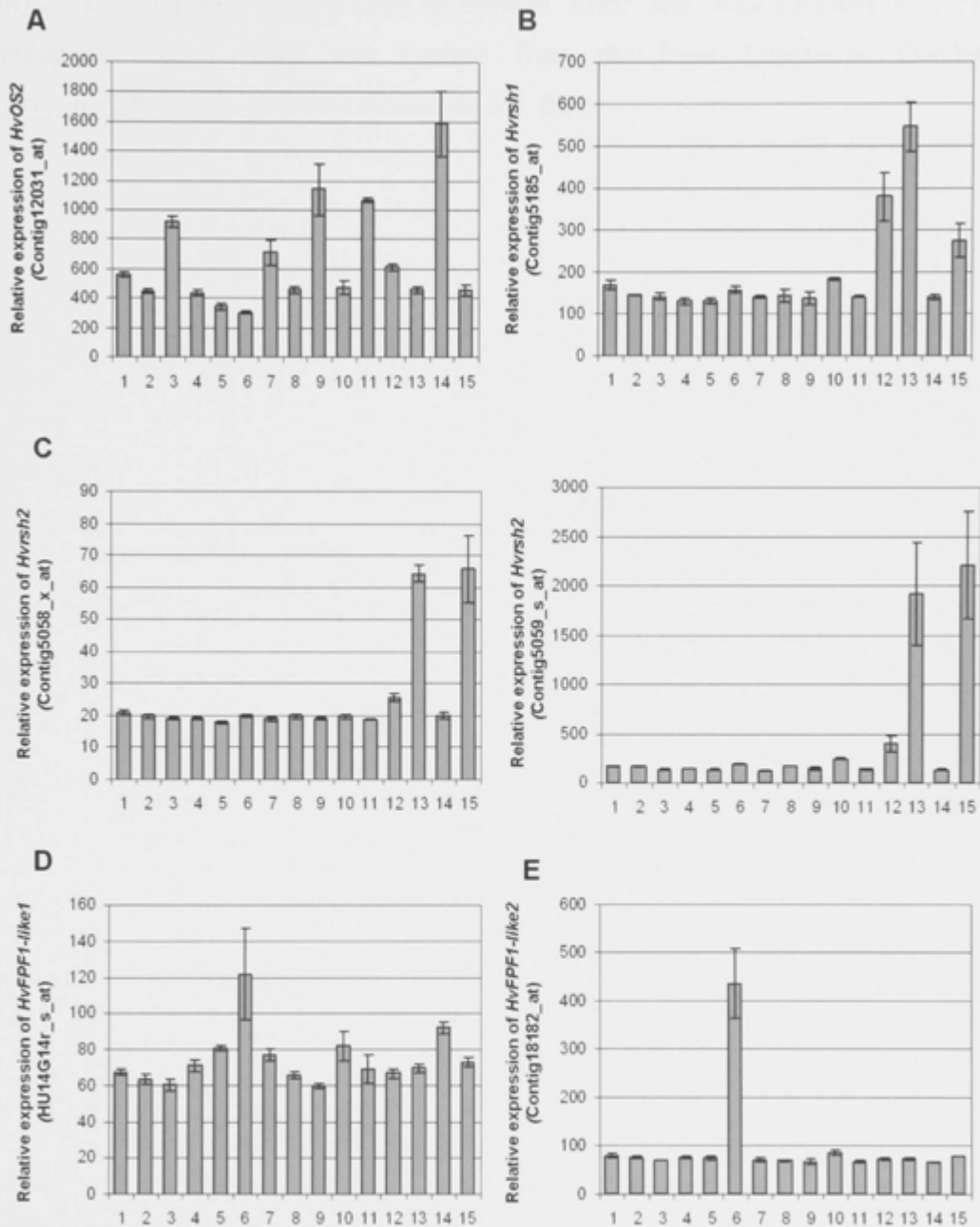

Supplemental Figure S10. Selected data from microarray analysis of gene expression during barley development (cv. Morex). Expression of *HvOS2* (A), *Hvrsh1* (B), *Hvrsh2* (C) *HvFPF1like-1* (D) and *HvFPF1like-2* (E). Treatments 1-15; 1) Germinating seed, coleoptyle. 2) Germinating seed, radicle. 3) Germinating seed, embryo. 4) Seedling, root. 5) Seedling, crown. 6) Seedling, leaf. 7) Immature, inflorescence. 8) Floral bracts, before anthesis. 9) Pistil, before anthesis. 10) Anthers,

before anthesis. 11) 5 DAP caryopsis. 12) 10 DAP caryopsis. 13) 16 DAP caryopsis. 14) 22 DAP embryo. 15) 22 DAP endosperm. Error bars show standard error of 3 biological repeats. Data was sourced from the Plant Expression Database (www.plexdb.org) Experiment Accession No. BB3.

Supplemental Table S1. Best Arabidopsis matches for HvOS1 and HvOS2

Protein Description	Accession	Identity	BLAST Score	E-value
HvOS1				
AGAMOUS-LIKE 19 (AGL19)	NP_194026	57/124 (45%)	108	3e-24
AGAMOUS-LIKE 14 (AGL14)	NP_192925	58/125 (46%)	107	8e-24
AGAMOUS-LIKE 20 (AGL20 / SOC1)	NP_182090	56/142 (39%)	105	2e-23
HvOS2				
AGAMOUS-LIKE 79 (AGL79)	NP_189645	70/143 (48%)	114	5e-26
AGAMOUS-LIKE 20 (AGL20 / SOC1)	NP_182090	46/67 (68%)	107	5e-24
AGAMOUS-LIKE 14 (AGL14)	NP_192925	63/140 (45%)	107	8e-24

Supplemental Table S2. Non -redundant blastn results for *HvOS1* and *HvOS2*

Description	Accession	Organism	Identity	BLAST Score	E-value
<i>HvOS1</i>					
<i>TaAGL42</i>	DQ512358	<i>T.aestivum</i>	95% (479/503)	793	0.0
<i>TaAGL33</i>	DQ512366	<i>T.aestivum</i>	86% (382/444)	464	2e-127
<i>TaAGL41</i>	DQ512357	<i>T.aestivum</i>	83% (407/487)	438	1e-119
<i>OsMADS51</i>	NM_001051770	<i>O. sativa</i>	79% (395/497)	324	3e-85
Hypothetical protein, mRNA	XM_002456815	<i>S. bicolor</i>	91% (206/225)	307	3e-80
<i>HvOS2</i>					
<i>TaAGL33</i>	DQ512366	<i>T.aestivum</i>	95% (449/471)	747	0.0
<i>TaAGL41</i>	DQ512357	<i>T.aestivum</i>	89% (424/472)	599	5e-168
<i>TaAGL42</i>	DQ512358	<i>T.aestivum</i>	84% (389/458)	448	2e-122
Hypothetical protein, mRNA	XM_002456815	<i>S. bicolor</i>	82% (356/429)	372	1e-99
Hypothetical protein, mRNA	NP_001140218	<i>Z.mays</i>	82% (353/430)	350	5e-93

Supplemental Table S3. Differentially expressed genes between plants over-expressing HvOS2 and wild-type siblings - See Excel File

Supplemental Table S4. Primers		
	Forward	Reverse
qRT-PCR primers		
<i>VRN1</i>	GGAAACTGAAGGCGAAGGTTGA	TGGTTCTTCCTGGCTCTGATATGTT
<i>HvOS1</i>	TTGCGGTTCTGGAAGGACC	AACTACTGGCATCTGAGTTGTC
<i>HvOS2</i>	CAATGCTGATGACTCAGATGCT	CGCTATTTGTTGCGCCAAT
<i>TmOS2</i>	CAATGCTGATGACTCAGATGCT	TCGTTGCGCCAACATCTTCT
<i>HvFPF1-like1</i>	GTCAAGAACC GCGACCACTT	CACATGCATAATCGCACACG
<i>HvFPF1-like2</i>	CGTCGACCTCATCTCCCTTC	AGTTGATTTGGGGCAGCTTG
<i>rsh1</i>	TGGGAATCAGCGGTCTAAGG	CTTTGGAAACGAGGCGAGAG
<i>rsh2</i>	GGCATCAACCCGGACTACAG	AAGGTCTTGCCGTCCTTGTC
ChIP primers		
<i>HvOS2</i>	CCCATCTCTGCACTCCCTG	GGAAAGCTAGCCTCCTCCTCCTCCGG
<i>TmVRN1</i> genotyping		
	CTGAAACATATCAGATCCAGG	AACTTTATTCTCCTCCTGCAG
		AATGGATTCGTGCATAAGTTGG

Chapter 4

Characterisation of barley (*Hordeum vulgare*) *SOC1-like* genes.

Abstract

SUPPRESSOR OF OVEREXPRESSION OF CONSTANS 1 (SOC1) is a MADS box gene that promotes flowering in Arabidopsis; loss of function mutations to *SOC1* delay flowering. *SOC1* is up-regulated by vernalization, photoperiod, gibberellic acid (GA) and development to induce the expression of genes involved in promoting floral transition. We examined whether barley homologues of *SOC1* are regulated by vernalization, photoperiod and development. Similar to Arabidopsis, the expression of barley *SOC1-like* genes increases during development but unlike in Arabidopsis the expression of *HvSOC1-like* genes is not influenced by photoperiod. The expression of *HvSOC1-like* genes is lower in the leaves and crown tissue of vernalized plants versus non-vernalized plants, the opposite response to that of *SOC1* in Arabidopsis. Constitutive over-expression of one of the barley *SOC1-like* genes, *HvSOC1-like1*, delayed flowering and caused dwarfing in barley plants. A *FLOWERING LOCUS T-like* gene, *HvFT3* and a gene potentially involved in GA biosynthesis, *ent-kaurene synthase-like*, showed reduced expression in barley plants constitutively over-expressing *HvSOC1-like1*. Overall these data suggest that cereal *SOC1-like* genes have evolved differently and have different biochemical functions than *SOC1* from Arabidopsis.

Introduction

Plants coordinate development with environmental cues to ensure that flowering occurs under favourable conditions, thus increasing the chances of reproductive success. Genes involved in regulating the transition to reproductive development have been studied extensively in the model plant *Arabidopsis* (reviewed by Amasino, 2010).

Certain ecotypes of *Arabidopsis* require vernalization to flower. The vernalization response in *Arabidopsis* is controlled by the floral repressor *FLOWERING LOCUS C (FLC)* (Michaels and Amasino, 1999; Sheldon et al., 1999). *FLC* encodes a MADS box protein that binds directly to regions of the promoter of *FLOWERING LOCUS T (FT)* to prevent flowering from occurring until after winter (Michaels and Amasino, 1999; Sheldon et al., 1999; Michaels et al., 2005; Helliwell et al., 2006). After plants have been vernalized *FT* is transcribed in the leaves of plants in response to long days and the FT protein travels to the shoot apex, which results in an acceleration of flowering (Kardailsky et al., 1999; Kobayashi et al., 1999; Corbesier et al., 2007).

In addition to repressing *FT*, *FLC* also represses the MADS box gene, *AGAMOUS-LIKE20 / SUPPRESSOR OF OVEREXPRESSION OF CONSTANS 1 (AGL20 / SOCI)*, hereafter referred to as *SOCI* (Hepworth et al., 2002; Michaels et al., 2005; Helliwell et al., 2006). *SOCI* is also up-regulated by photoperiod, gibberellic acid (GA) and developmental (age) regulatory pathways (Reviewed by Lee and Lee, 2010). Long-day induction of *SOCI* is regulated by FT and *CONSTANS (CO)* and occurs at the shoot apex (Borner et al., 2000; Onouchi et al., 2000; Samach et al., 2000). The up-regulation of *SOCI* results in the induction of genes involved in promoting floral transition (Borner et al., 2000; Onouchi et al., 2000; Samach et al., 2000; Hepworth et al., 2002). Although *SOCI* is repressed by *FLC* prior to vernalization, *SOCI* can be induced by cold independently from *FLC* (Moon et al., 2003; Sheldon et al., 2006), suggesting that there are other cold regulatory pathways that control *SOCI* expression.

SOCI is also up-regulated by the GA pathway (Borner et al., 2000; Moon et al., 2003). Exogenous application of GA induces *SOCI* expression, but this induction is perturbed in the *gai-1* mutant (Moon et al., 2003). Plants with loss of function mutations to *SOCI* are also less sensitive to GA treatment. The constitutive over-expression of *SOCI* can rescue non-flowering phenotypes of the GA deficient mutant,

gal-3 (Moon et al., 2003). The mechanism by which GA regulates *SOCI* is still unknown.

SOCI expression increases with development (Samach et al., 2000). Recent reports have described how a *SQUAMOSA PROMOTER BINDING PROTEIN-LIKE* (*SPL*) gene, *SPL9*, positively regulates *SOCI* during development (Wang et al., 2009). The expression of *SPL* genes is controlled by the microRNA (miR), miR156 (Wang et al., 2009). The expression of miR156 is high early in development but decreases with age (Wu and Poethig, 2006). This results in the age-dependant up-regulation of *SPL* genes and leads to induction of *SOCI* and another MADS box gene *FRUITFULL* (*FUL*) (Cardon et al., 1997; Wu and Poethig, 2006; Wang et al., 2009).

Two *SOCI-like* genes have been identified in rice, *OsMADS50* and *OsMADS56* (Lee et al., 2004; Ryu et al., 2009). *OsMADS50* null mutants and RNAi lines that have reduced expression of *OsMADS50* flower later than wild-type plants when grown under non-inductive day lengths (long-days), but flower at the same time as wild-type plants when grown under inductive day-lengths (short-days). (Lee et al., 2004; Ryu et al., 2009). *OsMADS56* null mutants and RNAi lines that have reduced expression of *OsMADS56* have no phenotypes but constitutive over-expression of *OsMADS56* delays flowering in long days (Lee et al., 2004; Ryu et al., 2009). Gene expression analysis of these transgenic plants revealed that the rice specific gene, *Early heading date 1* (*Ehd1*), is down-regulated (Lee et al., 2004; Ryu et al., 2009). These findings suggest that *SOCI-like* genes in rice are not a part of the conserved daylength pathway but rather are part of a rice specific regulatory pathway. This is supported by the observation that the expression levels of these genes are unaltered in *Hdl* null mutants (*Hdl* is the rice equivalent of *CO*) (Ryu et al., 2009). Expression analysis has also revealed that the transcript abundance of *OsMADS50* and *OsMADS56* increases with development, suggesting that some of the regulatory mechanisms of *SOCI-like* genes may be conserved between rice and Arabidopsis (Ryu et al., 2009). Overall however, it appears that the roles of *SOCI-like* genes are different in rice; a plant that flowers more rapidly in short days and does not require vernalization to flower (Lee et al., 2004; Ryu et al., 2009)

Although much is known about the regulation and function of *SOCI* in Arabidopsis, the understanding of the regulation and function of *SOCI* homologues in other species is not as detailed. Because *SOCI* is regulated by a number of different regulatory pathways and some of these pathways have evolved separately in different

plants (**Chapter 1**; Kim et al., 2009; Pin et al., 2010), it would be interesting to determine what role *SOCI-like* genes play in regulating flowering responses in temperate cereals; plants which flower more rapidly when grown in long days and also have a vernalization requirement, but are more closely related to rice than Arabidopsis. To investigate the function of *SOCI-like* genes in barley (*Hordeum vulgare*) two *SOCI-like* genes were identified and the expression of these genes was analysed to determine if they are regulated by vernalization, development and photoperiod. Transgenic barley plants constitutively over-expressing one of these genes were also developed and analysed to determine the effect on flowering time.

Results

Chromosomal location and comparisons with rice and Brachypodium

Partial sequences for two *SOCI-like* genes from barley were identified from searches of EST databases. Full length coding sequences for both genes were kindly provided Dr. M. Tadege. The barley genes were designated *HvSOCI-like1* and *HvSOCI-like2*. Phylogenetic analysis divided *SOCI-like* genes from grasses into two groups, Group A which includes *HvSOCI-like1*, *OsMADS50*, *BdSOCI-like1* and Group B that includes *HvSOCI-like2*, *OsMADS56*, *BdSOCI-like2* (Fig. 1A). The *SOCI-like1* gene from Brachypodium (*BdSOCI-like 1*) is located on a region syntenous to barley chromosome 4H (long arm, 111 cM) (Fig. 1B). Comparisons of the *SOCI-like2* gene from Brachypodium did not reveal syntenous location for *HvSOCI-like2* (Supplemental Fig. 1A).

A

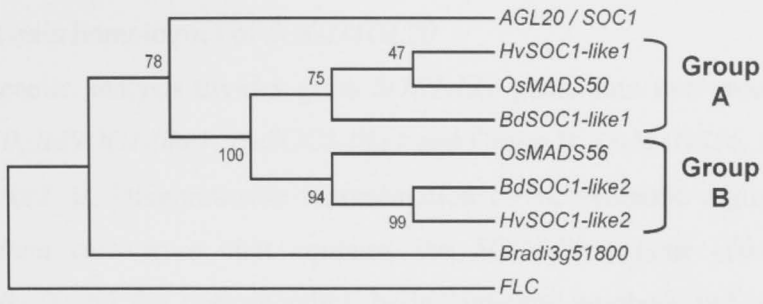

B

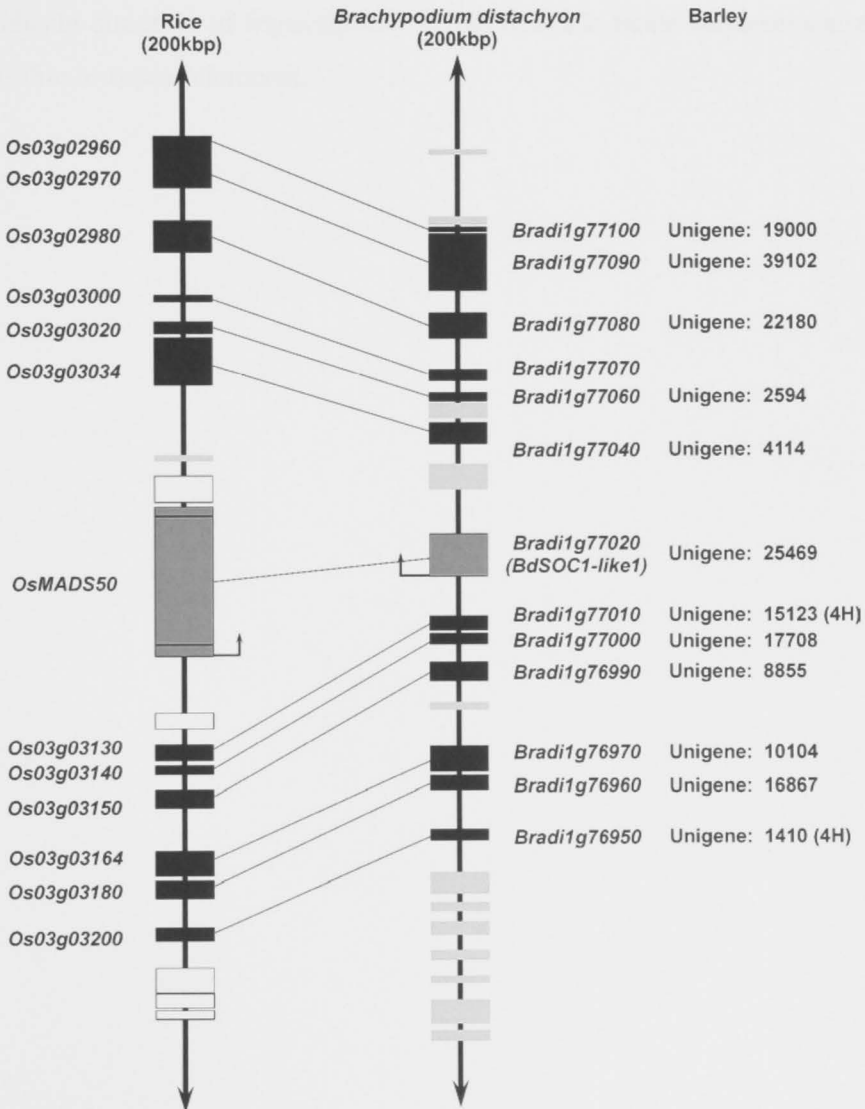

Figure 1. Grass homologues of *SOC1/AGL20*

A, Phylogenetic analysis divides grass *SOC1-like* genes into two groups, Group A: *OsMADS50*, *BdSOC1-like1*, *HvSOC1-like1* and Group B: *OsMADS56*, *BdSOC1-like2*, *HvSOC1-like2*. B, Diagrammatic representation of the syntenic region in rice and *Brachypodium distachyon* that contains the *SOC1-like1* gene (*OsMADS50* and *BdSOC1-like1*) and the corresponding barley unigene numbers and map locations. Arrows indicate direction of transcription. White boxes indicate sequences annotated as transposable or repeat elements.

Regulation of *HvSOC1-like* genes

The transcript levels of *HvSOC1-like1* and *HvSOC1-like2* were monitored in the leaves and crown tissue of vernalized versus non-vernalized plants with quantitative RT-PCR (qRT-PCR) (Fig. 2A, B and Supplemental Fig. 2). Transcript levels for *HvSOC1-like1* were lower in the leaves and crown tissue of plants that had been vernalized (Fig. 2A and B). The expression of *HvSOC1-like1* increased with development in both vernalized and non-vernalized plants (Fig. 2). The relative expression of *HvSOC1-like2* was lower than that of *HvSOC1-like1* but a similar expression pattern was observed for both genes in the leaves of plants after vernalization (Supplemental Fig. 2).

To determine if *HvSOC1-like1* expression is regulated by changes in photoperiod, transcript levels were monitored in the leaves of vernalized plants grown in either short or long days. The expression of *HvSOC1-like1* was similar regardless of daylength suggesting photoperiod does not regulate *HvSOC1-like1* expression (Fig. 2C).

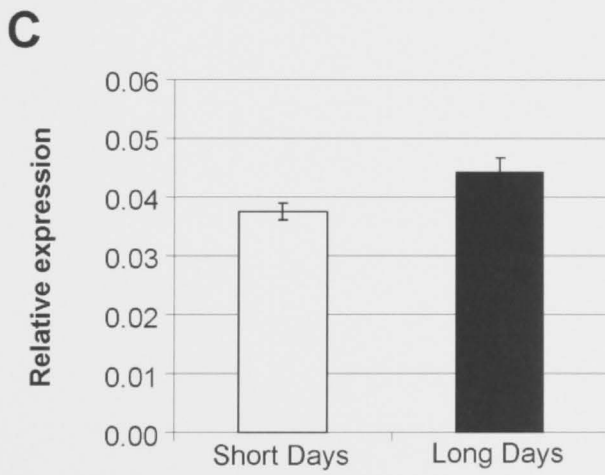
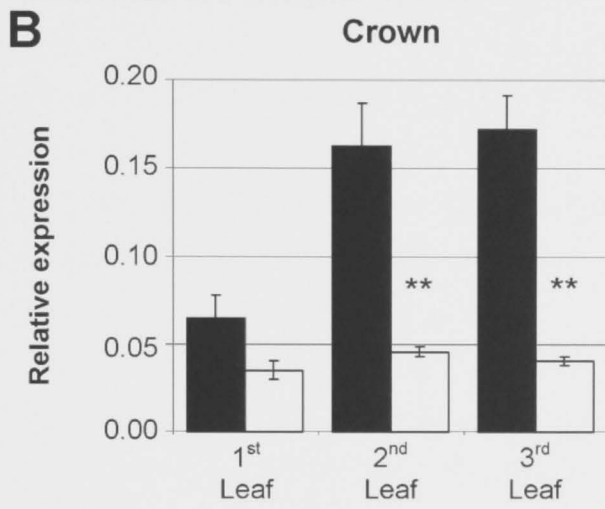
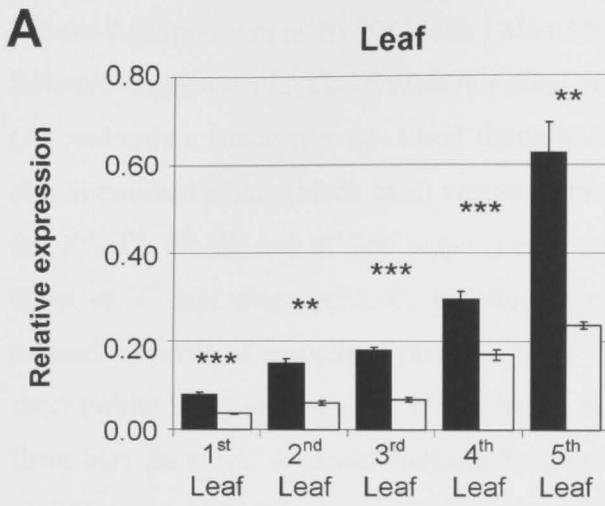

Figure 2. Expression of *HvSOC1-like1* after vernalization

Relative expression levels of *HvSOC1-like1* in the fully expanded leaf (no-sheath) (A) and crown tissue (the apex and tissue below, but not the roots) (B) taken from non-vernalized plants (black bars) versus plants vernalized for 49 days (white bars) at the 2nd, 3rd, 4th, 5th and 6th leaf stage (i.e. 1st leaf taken at the 2nd leaf stage, 2nd leaf taken at 3rd leaf stage etc.). C, Relative expression of *HvSOC1-like1* in the fully expanded leaves of vernalized plants at the 3rd leaf stage (cv. Sonja) grown in either short (white bars) or long days (black bars). Expression is shown relative to *ACTIN*. Error bars show SE. Asterisks indicate P values of Student t-test: **, P, <0.01; ***, P, <0.001. (min. of 3 biological repeats).

Constitutive over-expression of *HvSOC1-like1* causes dwarfing and delays flowering

To further investigate the function of *SOC1-like* genes in barley, plants were transformed with a construct that placed the cDNA sequence of *HvSOC1-like1* under the control of the maize (*Zea mays*) *UBIQUITIN* promoter. Of the T₀ plants (1st generation), a majority were late flowering and dwarfed compared with non-transformed plants. Three independent transgenic lines, the progeny of which showed segregation for the transgene construct, were chosen based on the gradient of phenotypes observed in these plants (i.e. strong to weak phenotypes) and were used to examine the effect of constitutive over-expression of *HvSOC1-like1* on flowering time (Line 5, 10 and 18). In all three lines a late flowering and dwarfed phenotype segregated with the transgene, consistent with the initial gradient of phenotypes observed in earlier generations (Fig. 3A).

To determine if the dwarfing phenotypes were caused by a disruption to GA metabolism, exogenous GA₃ was applied to the leaves of plants with the strongest phenotype (line 5). A single application (10μL) of GA₃ (2.5μg/μL) temporarily restored the dwarfed phenotype of plants constitutively over-expressing *HvSOC1-like1* back to a pattern of growth more similar to wild-type sibling plants (Fig. 3B).

Transcript levels of several genes known to be important for promoting flowering were measured to investigate the molecular basis for the late flowering phenotypes of plants constitutively over-expressing *HvSOC1-like1*, these included *HvVRN1*, *HvFT1*, *HvODDSOC2* (*HvOS2*) and *HvFLOWERING PROMOTER FACTOR1-like1* (*HvFPF1-like1*) (Fig. 3C-F and Supplemental Fig. 3A-C). As expected the expression of *HvSOC1-like1* was higher in plants that had inherited the transgene (Fig. 3C). Transcript levels for *HvVRN1* and *HvFT1* did not differ between transgenic plants and the sibling plants that did not inherit the transgene (Supplemental Fig. 3A and B). Transcript levels of *HvOS2* and *HvFPF1-like1* were unchanged in plants constitutively over-expressing *HvSOC1-like1* (Fig. 3D and Supplemental Fig. 3C). Expression of another *FT-like* gene, *HvFT3*, was lower in plants constitutively over-expressing *HvSOC1-like1* (Fig. 3E). The expression levels of several genes involved in regulating GA biosynthesis were measured to investigate the molecular basis of the dwarfing phenotypes of plants constitutively over-expressing *HvSOC1-like1*. Transcript levels for *ent-kaurene oxidase* (*HvKO1*), *ent-kaurenoic acid oxidase* (*HvKAO1*), and *20-Oxidase* (*Hv20ox2*) did not differ

between plants constitutively over-expressing *HvSOC1-like1* and sibling plants that did not inherit the transgene (Supplemental Fig. 3D-F). The expression of an *ent-kaurene synthase-like* (AY551437) gene was lower in plants constitutively over-expressing *HvSOC1-like1* compared to sibling plants that did not inherit the transgene (Fig. 3F).

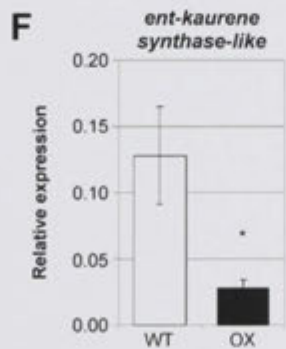
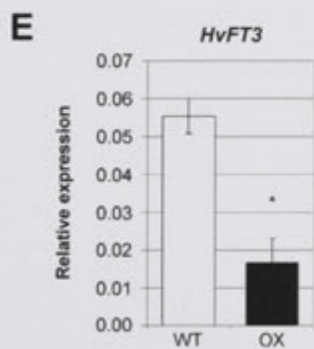
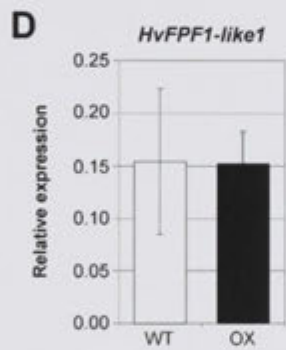
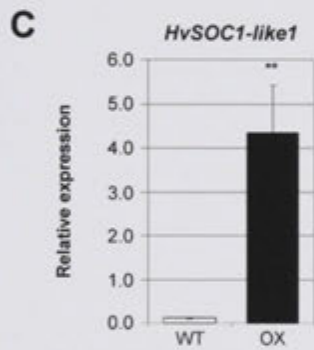
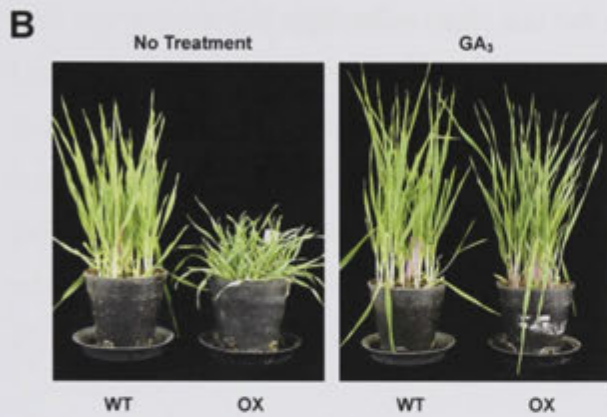
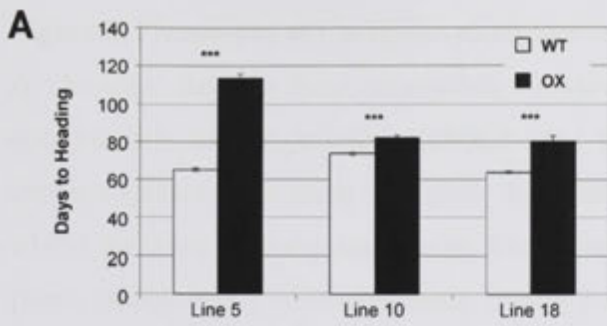

Figure 3. Phenotypes of transgenic plants that over-express *HvSOC1-like1*.

A, Average days to head emergence (heading date) of transgenic barley plants constitutively over-expressing *HvSOC1-like1* (black) versus sibling null segregant controls (plants from same transgenic line that did not inherit the transgene) (WT, white) for three different segregating lines (line 5, 10 and 18). B, Transgenic barley plants constitutively over-expressing *HvSOC1-like1* versus null segregants (Line 5) with and without GA application (right and left respectively). GA was applied at the 3 Leaf Stage and images were taken approximately 2-3 weeks after application. C-F, Relative expression of *HvSOC1-like1* (C), *HvFPF1-like1* (D), *HvFT3* (E) and *entkaurene synthase-like* (F) in transgenic (black) versus null segregant control plants (white) at the 3rd leaf stage. Expression was assayed by qRT-PCR and is shown relative to *ACTIN*. Error bars show SE. Asterisks indicate P values of ANOVA test: *, P, < 0.05; **, P, < 0.01 (min. of 3 biological repeats).

Discussion

Expression analyses revealed key differences in the way *HvSOC1-like* genes are regulated in barley compared to *SOC1* in Arabidopsis. The expression of barley *SOC1-like* genes is not regulated by photoperiod. Furthermore, the expression of *HvSOC1-like* genes is lower in vernalized leaf and crown tissue than in non-vernalized leaf and crown tissue, the opposite of what occurs in Arabidopsis (Fig. 2A Supplemental Fig. 2). Similar to Arabidopsis the expression levels of barley *SOC1-like* genes increases with development, especially in the leaves of non-vernalized plants (Fig. 2 and Supplemental Fig. 2). Previous studies have found that a *SOC1-like* gene in wheat (*WSOC1*) is also up-regulated during development, suggesting that the developmental regulation of *SOC1-like* genes is conserved in cereals and Arabidopsis (Shitsukawa et al., 2007).

Overexpression of *SOC1* from Arabidopsis and *SOC1-like* genes from *Nicotiana tabacum* and *Petunia hybrida* leads to rapid flowering when over-expressed in those plants (Borner et al., 2000; Ferrario et al., 2004; Smykal et al., 2007). *SOC1-like* genes from *Eucalyptus grandis*, *Vitis vinifera* and *Citrus sinensis* also cause early flowering when over-expressed in Arabidopsis (Watson and Brill, 2004; Sreekantan and Thomas, 2006; Tan and Swain, 2007). Overexpression of the wheat (*Triticum aestivum*) *SOC1-like* gene, *WSOC1*, in Arabidopsis produced mixed results when compared with previous studies (Shitsukawa et al., 2007). Overexpression of *WSOC1* did not affect flowering time in long days (Shitsukawa et al., 2007). Plants did flower earlier when they were grown in short days (Shitsukawa et al., 2007). In barley, overexpression of *HvSOC1-like1* delayed flowering and dwarfed plants (Fig. 3A and B). These phenotypes are different to what has previously been reported for the overexpression of *SOC1-like* genes in many other species, but have some similarities to findings from rice. Constitutive over-expression of *OsMADS50*, the rice homologue of *HvSOC1-like1*, caused dwarfing in some plants but the effect on flowering time in these plants was mixed, with some plants flowering early and others flowering late (Lee et al., 2004). A late flowering phenotype was also observed in rice plants constitutively over-expressing *OsMADS56*; another rice *SOC1-like* gene (Ryu et al., 2009).

Why overexpression of *HvSOC1-like1* caused late flowering and dwarfing as opposed to early flowering is unclear. One explanation could be that the phenotypes of plants constitutively over-expressing *HvSOC1-like1* are an artefact of constitutively

over-expressing a MADS box gene. MADS box proteins are involved in regulating many different aspects of plant development and interact with each other to form higher order structures to regulate transcription (Shore and Sharrocks, 1995; Riechmann and Meyerowitz, 1997). The constitutive over-expression of *HvSOC1-like1* could disrupt these interactions and lead to the dwarfed late flowering phenotypes seen in these plants (Fig. 3A and B). However, other MADS box genes have been over-expressed in barley but without the same effect on growth (Trevaskis et al., 2007 and unpublished data). The reason why overexpression of *HvSOC1-like* produces different phenotypes could be explained by the allele of *HvSOC1-like1* chosen for over-expression; if the cDNA sequence of *HvSOC1-like1* used in this study is a variant that is defective in some way, then over-expressing it may result in late flowering and dwarfing. Screening of different cultivars could reveal if there is any natural variation for *HvSOC1-like1* and may also help understand more about the function of *SOC1-like* genes in temperate cereals.

Subtle differences in the protein sequences of *SOC1* and *HvSOC1-like* proteins could also explain the differences in phenotypes of barley plants constitutively over-expressing *HvSOC1-like1*. The prediction of motifs that are thought to be important for facilitating interactions between MADS box proteins shows that a number of motifs that are found in the protein sequence of *Arabidopsis SOC1* are also found in the *VRN1*-like protein, *Lolium perenne* *MADS1* (*LpMADS1*) (van Dijk et al., 2010). The amino acid sequences of *SOC1*-like and *VRN1* from barley were analysed for the presence of these motifs and compared to the results from *SOC1* and *AP1* from *Arabidopsis* (Fig. 4). Two motifs, 8A and 9B that are found in the C-terminal region of *SOC1* were absent from *HvSOC1-like1* or *HvSOC1-like2* (Fig. 4, Supplemental Fig. 4). However, both motifs were present in the C-terminal region of the *VRN1* protein sequence from barley (Fig. 4, Supplemental Fig. 4 and Supplemental Table 1). In addition to the differences in structural motifs it has been demonstrated that the *VRN1*-like protein, *LpMADS1*, can interact with many of the proteins *SOC1* can interact with (Ciannamea et al., 2006). These findings suggest that *VRN1* and *VRN1*-like proteins regulate many of the processes in grasses that *SOC1* regulates in *Arabidopsis* (Ciannamea et al., 2006). This is supported by the observation that the expression pattern of *VRN1-like* genes during development is similar to that of *SOC1* in *Arabidopsis* (Danyluk et al., 2003; Trevaskis et al., 2003; Yan et al., 2003; Ciannamea et al., 2006).

If VRN1 is regulating processes in grasses that SOC1 regulates in Arabidopsis, then this could explain why constitutive over-expression of *HvSOC1-like1* does not lead to early flowering. Furthermore, the late flowering and dwarfing phenotypes of the plants constitutively over-expressing could be the result of the HvSOC1-like1 protein competing with VRN1, leading to the displacement of VRN1 from regulatory complexes and resulting in the dilution of VRN1 activity. An interesting experiment to carry out would be to determine if the overexpression of *HvSOC1-like1* has the same effect in varieties that require vernalization to flower ('winter' barley varieties). By constitutively over-expressing *SOC1-like* genes in a variety that requires vernalization to flower, competition with VRN1 could be avoided. Unfortunately at present no transformable 'winter' cultivars of barley have been identified. This could be solved by backcrossing the transformable cultivar, Golden Promise, into a 'winter' background.



Figure 4. Comparison of interaction motifs in Arabidopsis AP1 and SOC1 protein sequences with barley VRN1 and SOC1-like protein sequences.

The interaction motifs 8A and 9B found in the Arabidopsis SOC1 protein sequence but not AP1, are also present in VRN1 but not in the sequences of barley SOC1-like proteins. Square boxes indicate motifs found in SOC1 but not AP1. Diamond box indicates motif found in AP1 and not SOC1. Ovals indicate motifs found in both SOC1 and AP1 protein sequences. (Motif definitions can be found in Supplemental Table 1 and van Dijk et al., 2010).

There are some similarities between the phenotypes of plants constitutively over-expressing *HvSOC1-like1* and plants constitutively over-expressing *HvOS2* (**Chapter 3**); flowering is delayed and plants appear dwarfed in both sets of transgenic plants. However, more detailed analysis shows there are key differences between the two lines. The growth habit of plants constitutively over-expressing *HvSOC1-like1* is more prostrate than plants constitutively over-expressing *HvOS2* (Fig. 3B, **Chapter 3**, Fig. 5B and Supplemental Fig. S6). The growth habit of plants constitutively over-expressing *HvSOC1-like1* is also more sensitive to growing conditions than *HvOS2* constitutive over-expression lines, with differences in the severity of phenotypes of plants constitutively over-expressing *HvSOC1-like1* observed during different plantings (data not presented). There are also differences in the molecular phenotypes of plants constitutively over-expressing *HvSOC1-like1* and *HvOS2*. The constitutive over-expression of *HvOS2* leads to the down-regulation of *HvFPF1-like1* which might explain the late flowering phenotype and some of the cell elongation phenotypes observed in these plants (**Chapter 3**). The expression of *HvOS2* and *HvFPF-like1* is unchanged in plants constitutively over-expressing *HvSOC1-like1* (Fig. 3C), which suggests that there are key mechanistic differences between the phenotypes of plants constitutively over-expressing *HvSOC1-like1* and *HvOS2*. However, the isolation and characterisation of loss of function mutants for both these genes would be essential for determining their function.

In conclusion, the expression of *SOC1-like* genes in cereals increases with development and this aspect may be regulated in a similar way to *SOC1* in Arabidopsis. The expression of *HvSOC1-like* genes is not regulated by photoperiod and the regulation by vernalization is different to *SOC1*. These differences combined with the fundamental differences in the way flowering time is regulated in temperate cereals versus Arabidopsis, likely contribute to the reasons why barley plants constitutively over-expressing *HvSOC1-like* produce such different results to those in Arabidopsis.

Materials and Methods:

Plant Growth

Barley plants (*Hordeum vulgare*) were grown in glasshouses (18 ± 2 °C) in long days (16-h light/8-h dark), with supplementary light when natural levels dropped below 200 μ E. For controlled growth conditions plants were grown in growth chambers

(15°C) with long (16-h light/8-h dark) or short days (8-h light/16-h dark) under a mix of incandescent and fluorescent lighting. In instances where plants were vernalized, seeds were imbibed and germinated on moist filter paper for 4-7 weeks at 4°C in the dark and then shifted to glasshouse or growth cabinets.

Flowering Time Measurements.

Heading date was measured as the day when the head first emerged from the sheath on the main shoot ($Z = 13,21$, (Zadoks et al., 1974).

Gene Expression Analysis

Total RNA was extracted using the method of Chang et al. (1993). RNA was treated with DNase (Promega) to remove any genomic DNA contamination prior to cDNA synthesis. cDNA was prepared for qRT-PCR by using an oligo(T) primer (T18[G/C/A]) to prime first-strand complementary DNA (cDNA) synthesis from 1-5 µg of total RNA with SuperScript III reverse transcriptase enzyme (Invitrogen). qRT-PCR was performed on a Rotor-Gene 3000 real-time cycler (Corbett Research). The primers used for *ACTIN*, *HvVRN1*, *HvFT1*, *HvOS2* and *HvFPF1-like1* have been described previously (Trevaskis et al., 2006, Hemming et al., 2008, Greenup et al., 2010) and additional primers are detailed in Supplemental Table 2. qRT-PCR was performed using Platinum Taq DNA polymerase (Invitrogen). Cycling conditions were 4 minutes at 94°C, 40 cycles of 10 s at 95°C, 15 s at 60°C, and 20 s at 72°C, followed by a melting-curve program (72°C–95°C with a 5-s hold at each temperature). Fluorescence data were acquired at the 72°C step and during the melting-curve program. Expression levels of genes of interest were calculated relative to *ACTIN* using the comparative quantification analysis method (Rotogene-5; Corbett Research), which takes into account the amplification efficiency of each primer set. Data presented are averages of a minimum of three biological replicates unless stated otherwise and the error bars show SE.

Barley *SOCI-like* cDNA Sequences and Transgenic plants

Sequences of *HvSOCI-like1* and *HvSOCI-like2* were identified and provided by Dr. M. Tadege. Seeds of plants constitutively over-expressing *HvSOCI-like1* were also provided by Dr. M. Tadege. Segregation analysis was undertaken as described in Chapter 3.

Sequence Database Searches

Sequence database searches (nucleotide and protein) were performed using the Basic Local Alignment Search Tool (BLAST) at the National Center for Biotechnology (NCBI) (<http://blast.ncbi.nlm.nih.gov/Blast.cgi>), Brachybase.org (<http://blast.brachypodium.org/>) and the Rice Genome Annotation Project (http://rice.plantbiology.msu.edu/analyses_search_blast.shtml).

Phylogenetic Analysis

Alignments of full nucleotide coding sequences were performed using MUSCLE v.3.6 (Edgar, 2004) and were edited using the BioEdit interface (v. 7.0.9.0) (Hall, 1999), (Supplemental Fig. 1B). Phylogenetic analyses were conducted in MEGA4, using the UPGMA method (default settings) (Sneath and Sokal, 1973). Bootstrap values were calculated using 10000 replicates.

Literature Cited

- Amasino R** (2010) Seasonal and developmental timing of flowering. *The Plant Journal* **61**: 1001-1013
- Borner R, Kampmann G, Chandler J, Gleißner R, Wisman E, Apel K, Melzer S** (2000) A MADS domain gene involved in the transition to flowering in *Arabidopsis*. *The Plant Journal* **24**: 591-599
- Cardon GH, Höhmann S, Nettekheim K, Saedler H, Huijser P** (1997) Functional analysis of the *Arabidopsis thaliana* SBP-box gene *SPL3*: a novel gene involved in the floral transition. *The Plant Journal* **12**: 367-377
- Chang S, Puryear J, Cairney J** (1993) A simple and efficient method for isolating RNA from pine trees. *Plant Molecular Biology Reporter* **11**: 113-116
- Ciannamea S, Kaufmann K, Frau M, Tonaco IAN, Petersen K, Nielsen KK, Angenent GC, Immink RGH** (2006) Protein interactions of MADS box transcription factors involved in flowering in *Lolium perenne*. *Journal of Experimental Botany* **57**: 3419-3431
- Corbesier L, Vincent C, Jang S, Fornara F, Fan Q, Searle I, Giakountis A, Farrona S, Gissot L, Turnbull C, Coupland G** (2007) FT Protein Movement Contributes to Long-Distance Signalling in Floral Induction of *Arabidopsis*. *Science* **316**: 1030-1033
- Danyluk J, Kane NA, Breton G, Limin AE, Fowler DB, Sarhan F** (2003) *TaVRT-1*, a putative transcription factor associated with vegetative to reproductive transition in cereals. *Plant Physiology* **132**: 1849-1860
- Edgar RC** (2004) MUSCLE: multiple sequence alignment with high accuracy and high throughput. *Nucleic Acids Research* **32**: 1792-1797
- Ferrario S, Busscher J, Franken J, Gerats T, Vandenbussche M, Angenent GC, Immink RGH** (2004) Ectopic Expression of the *Petunia* MADS Box Gene *UNSHAVEN* Accelerates Flowering and Confers Leaf-Like Characteristics to Floral Organs in a Dominant-Negative Manner. *Plant Cell* **16**: 1490-1505
- Greenup AG, Sasani S, Oliver SN, Talbot MJ, Dennis ES, Hemming MN, Trevaskis B** (2010) *ODDSOC2* Is a MADS Box Floral Repressor That Is Down-Regulated by Vernalization in Temperate Cereals. *Plant Physiology* **153**: 1062-1073

- Hall TA** (1999) BioEdit: a user-friendly biological sequence alignment editor and analysis program for Windows 95/98/NT. *Nucleic Acids Symposium Series* **41**: 95-98
- Helliwell CA, Wood CC, Robertson M, Peacock WJ, Dennis ES** (2006) The Arabidopsis FLC protein interacts directly in vivo with *SOC1* and *FT* chromatin and is part of a high-molecular-weight protein complex. *The Plant Journal* **46**: 183-192
- Hemming MN, Peacock WJ, Dennis ES, Trevaskis B** (2008) Low-temperature and daylength cues are integrated to regulate *FLOWERING LOCUS T* in barley. *Plant Physiology* **147**: 355-366
- Hepworth SR, Valverde F, Ravenscroft D, Mouradov A, Coupland G** (2002) Antagonistic regulation of flowering-time gene *SOC1* by CONSTANS and FLC via separate promoter motifs. *EMBO Journal* **21**: 4327-4337
- Kardailsky I, Shukla VK, Ahn JH, Dagenais N, Christensen SK, Nguyen JT, Chory J, Harrison MJ, Weigel D** (1999) Activation Tagging of the Floral Inducer *FT*. *Science* **286**: 1962-1965
- Kim D-H, Doyle MR, Sung S, Amasino RM** (2009) Vernalization: Winter and the Timing of Flowering in Plants. *Annual Review of Cell and Developmental Biology* **25**: 277-299
- Kobayashi Y, Kaya H, Goto K, Iwabuchi M, Araki T** (1999) A Pair of Related Genes with Antagonistic Roles in Mediating Flowering Signals. *Science* **286**: 1960-1962
- Lee J, Lee I** (2010) Regulation and function of *SOC1*, a flowering pathway integrator. *Journal of Experimental Botany* **61**: 2247-2254
- Lee SY, Kim J, Han JJ, Han MJ, An GH** (2004) Functional analyses of the flowering time gene *OsMADS50*, the putative *SUPPRESSOR OF OVEREXPRESSION OF CO 1/AGAMOUS-LIKE 20 (SOC1/AGL20)* ortholog in rice. *The Plant Journal* **38**: 754-764
- Michaels SD, Amasino RM** (1999) *FLOWERING LOCUS C* Encodes a Novel MADS Domain Protein That Acts as a Repressor of Flowering. *Plant Cell* **11**: 949-956
- Michaels SD, Himmelblau E, Kim SY, Schomburg FM, Amasino RM** (2005) Integration of Flowering Signals in Winter-Annual Arabidopsis. *Plant Physiology*. **137**: 149-156

- Moon J, Suh SS, Lee H, Choi KR, Hong CB, Paek NC, Kim SG, Lee I** (2003) The *SOCI* MADS-box gene integrates vernalization and gibberellin signals for flowering in Arabidopsis. *The Plant Journal* **35**: 613 - 623
- Onouchi H, Igeno MI, Perilleux C, Graves K, Coupland G** (2000) Mutagenesis of Plants Over-expressing *CONSTANS* Demonstrates Novel Interactions among Arabidopsis Flowering-Time Genes. *Plant Cell* **12**: 885-900
- Pin PA, Benlloch R, Bonnet D, Wremerth-Weich E, Kraft T, Gielen JJJ, Nilsson O** (2010) An Antagonistic Pair of *FT* Homologs Mediates the Control of Flowering Time in Sugar Beet. *Science* **330**: 1397-1400
- Riechmann JL, Meyerowitz EM** (1997) MADS domain proteins in plant development. *Biological Chemistry* **378**: 1079-1101
- Ryu C, Lee S, Cho L, Kim S, Lee Y, Choi S, Jeong H, Yi J, Park S, Han C, An G** (2009) *OsMADS50* and *OsMADS56* function antagonistically in regulating long day (LD)-dependent flowering in rice. *Plant, Cell and Environment* **32**: 1412-1427
- Samach A, Onouchi H, Gold SE, Ditta GS, Schwarz-Sommer Z, Yanofsky MF, Coupland G** (2000) Distinct Roles of *CONSTANS* Target Genes in Reproductive Development of Arabidopsis. *Science* **288**: 1613-1616
- Sheldon CC, Burn JE, Perez PP, Metzger J, Edwards JA, Peacock WJ, Dennis ES** (1999) The *FLF* MADS Box Gene: A Repressor of Flowering in Arabidopsis Regulated by Vernalization and Methylation. *Plant Cell* **11**: 445-458
- Sheldon CC, Jean Finnegan E, Dennis ES, James Peacock W** (2006) Quantitative effects of vernalization on *FLC* and *SOCI* expression. *The Plant Journal* **45**: 871-883
- Shitsukawa N, Ikari C, Mitsuya T, Sakiyama T, Ishikawa A, Takumi S, Murai K** (2007) Wheat *SOCI* functions independently of *WAP1/VRN1*, an integrator of vernalization and photoperiod flowering promotion pathways. *Physiologia Plantarum* **130**: 627-636
- Shore P, Sharrocks AD** (1995) The MADS box Family of Transcription Factors. *European Journal of Biochemistry* **229**: 1-13
- Smykal P, Gennen J, De Bodt S, Ranganath V, Melzer S** (2007) Flowering of strict photoperiodic *Nicotiana* varieties in non-inductive conditions by transgenic approaches. *Plant Molecular Biology* **65**: 233-242

- Sneath PHA, Sokal RR** (1973) Numerical taxonomy: the principles and practice of numerical classification. Freeman, San Francisco
- Sreekantan L, Thomas MR** (2006) *VvFT* and *VvMADS8*, the grapevine homologues of the floral integrators *FT* and *SOCI*, have unique expression patterns in grapevine and hasten flowering in *Arabidopsis*. *Functional Plant Biology* **33**: 1129-1139
- Tan FC, Swain SM** (2007) Functional characterization of *AP3*, *SOCI* and *WUS* homologues from citrus (*Citrus sinensis*). *Physiologia Plantarum* **131**: 481-495
- Trevaskis B, Bagnall DJ, Ellis MH, Peacock WJ, Dennis ES** (2003) MADS box genes control vernalization-induced flowering in cereals. *Proceedings of the National Academy of Sciences of the United States of America* **100**: 13099-13104
- Trevaskis B, Hemming MN, Peacock WJ, Dennis ES** (2006) *HvVRN2* Responds to Daylength, whereas *HvVRN1* Is Regulated by Vernalization and Developmental Status. *Plant Physiology* **140**: 1397-1405
- Trevaskis B, Tadege M, Hemming MN, Peacock WJ, Dennis ES, Sheldon C** (2007) *Short Vegetative Phase-like* MADS-box genes inhibit floral meristem identity in barley. *Plant Physiology* **143**: 225-235
- van Dijk ADJ, Morabito G, Fiers M, van Ham RCHJ, Angenent GC, Immink RGH** (2010) Sequence Motifs in MADS Transcription Factors Responsible for Specificity and Diversification of Protein-Protein Interaction. *PLoS Computational Biology* **6**: e1001017
- Wang J-W, Czech B, Weigel D** (2009) miR156-Regulated *SPL* Transcription Factors Define an Endogenous Flowering Pathway in *Arabidopsis thaliana*. *Cell* **138**: 738-749
- Watson JM, Brill EM** (2004) *Eucalyptus grandis* has at least two functional *SOCI-like* floral activator genes. *Functional Plant Biology* **31**: 225-234
- Wu G, Poethig RS** (2006) Temporal regulation of shoot development in *Arabidopsis thaliana* by miR156 and its target *SPL3*. *Development* **133**: 3539-3547
- Yan L, Loukoianov A, Tranquilli G, Helguera M, Fahima T, Dubcovsky J** (2003) Positional cloning of the wheat vernalization gene *VRN1*. *Proceedings of the National Academy of Sciences of the United States of America* **100**: 6263-6268

Zadoks JC, Chang TT, Konzak CF (1974) Decimal Code for Growth Stages of Cereals. Weed Research 14: 415-421

Supplemental Data

A

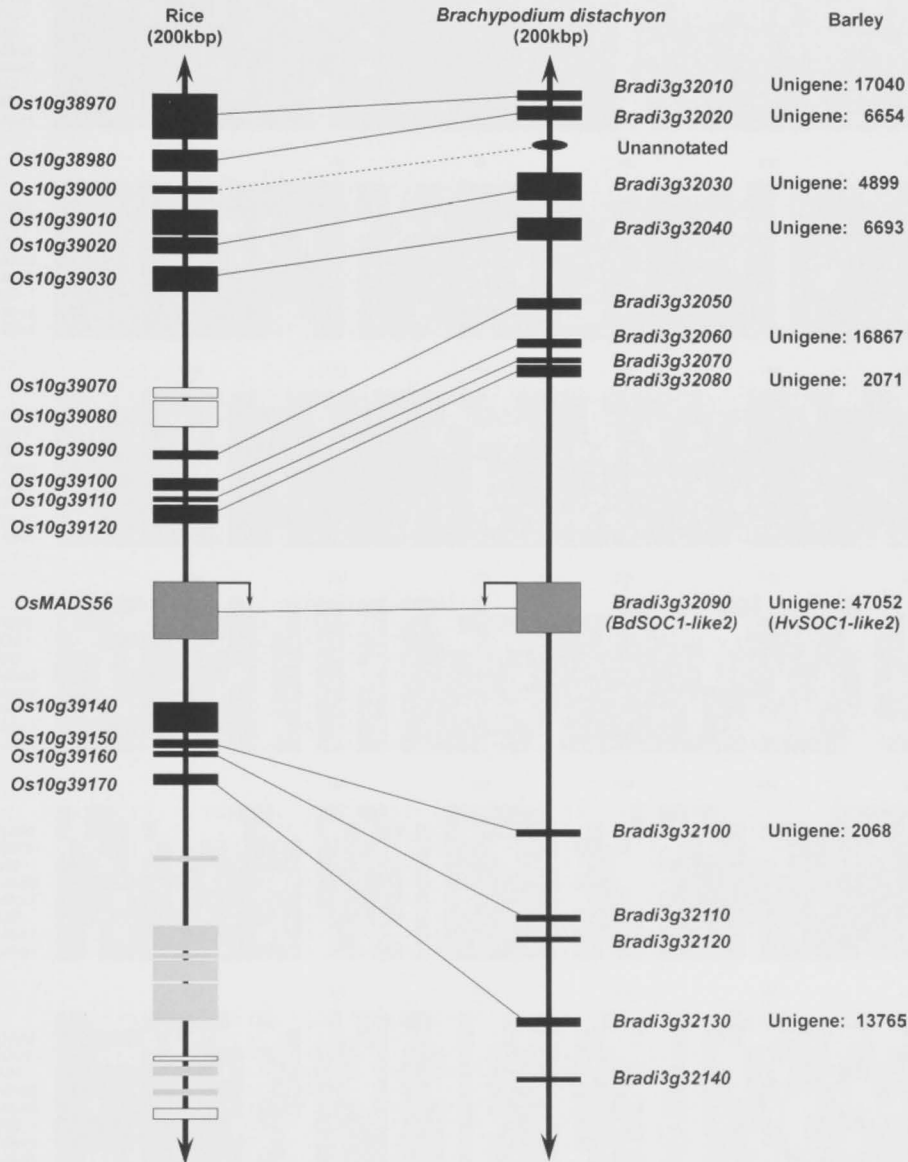

B

	10	20	30	40	50	60	
FLC	A T G G G A A A A A A A A A C T A G A A A T G A A G C G A A T G A G A A C A A A A G T A G C C G A C A A T C A C C	60					
Bradi3g51800	A T G G G A A A G G G G A A A G T T G A G T G A A G C G A T G A G A A C A A G A T C A A C A G C A G G T C A C C	60					
AGL20/SOC1	A T G G T G A A G G G G A A A G T T G A G T G A A G C G A T G A G A A T G A A C A G C A A G C A A C A A T G A C T	60					
OsMADS56	A T G G T G C G G G G G A A S A C G G A G T G A A G C G G A T G A G A A C C G A C G A G C C G G C A G G T G A C C	60					
HvSOC1-like2	A T G G T G C G G G G G A A G A C G G A G T G A A G C G G A T A G A G A A C G C A C G A G C C G G C A G G T G A C C	60					
BdSOC1-like2	A T G G T G C G G G G G A A G A C G G A G T G A A G C G G A T A G A G A A C A C G A C G A G C C G G C A G G T G A C C	60					
OsMADS50	A T G G T G C G G G G G A A G A C G C A G T G A A G C G G A T G A G A A C C G A C G A G C C G G C A G G T G A C C	60					
BdSOC1-like1	A T G G T G C G G G G G A A G A C G C A G T G A A G C G G A T G A G A A C C G A C G A G C C G G C A G G T G A C C	60					
HvSOC1-like1	A T G G T G C G G G G G A A G A C G C A G A T G A A G C G G A T A G A G A A C C G A C G A G C C G G C A G G T G A C C	60					
	70	80	90	100	110	120	
FLC	T T C T C C A A A A G T G C A A C G G T C T C A T C G A G A A A G C T C G T C A G C T T C T T T T C T C T G T G A C	120					
Bradi3g51800	T T C T C C A A A G C C C G C A A C G G C T C T C T C A A G A A G G C C T A C G A G C T C T C C G T G C T C T G C G A C	120					
AGL20/SOC1	T T C T C C A A A A A A A A I S G T T G T T G A A G A A G C C T T G A G C T C T C A T G C T T G T G A T	120					
OsMADS56	T T C T C C A A A G C C G A A I S G C T C T C A A G A A G G C T T C G A G C T C T C G T C T C T G T G A T	120					
HvSOC1-like2	T T C T C C A A G C C A A C A C G G C T G C T C A A G A A G C C T T C G A G C T C T C G S T G C T C T G C G A C	120					
BdSOC1-like2	T T C T C C A A G C C G C A A C G G G C T G C T C A A G A A G C C T T C G A G C T C T C C G T G C T C T G C G A C	120					
OsMADS50	T T C T C C A A G C C C C A A C G G C T G C T C A A G A A G G C C T T C G A G C T C T C C G T C T C T G C G A C	120					
BdSOC1-like1	T T C T C C A A G C C C C G G C G G C T G C T C A A G A A G G C G C A C G A G C T C T C C G T C T C T G C G A T	120					
HvSOC1-like1	T T C T C C A A G C C C C G G G S G C T G C T C A A G A A G G C C T T C G A G C T C T C C G T C T C T G C G A C	120					
	130	140	150	160	170	180	
FLC	G C A T C C C T C G G C T C T C T C G T C T C C C C G C T C G G C A A G C T C T A C A G C T T C T C C C G G T	180					
Bradi3g51800	G C C G A G G T T G C C T C A T C A T C T T C T C T C T A A A G G C A A C T T A T G A A T T C G C A G C T C C	180					
AGL20/SOC1	G C T T A A G T T C C T C T A T C A T C T T C T C T C T A A A G G C A A C T T A T G A A T T C G C A G C T C C	180					
OsMADS56	G C C G A G G T C G C C T C A T C T C T T C T C C C C C G C G G G C G A G C T C A C G A T T C G C A G C G C C	180					
HvSOC1-like2	G C C G A G G T C G G C T C G T C G T C T T C C C C C T C G G G C A G G C T C T A C G A T T C G C C A G C G C C	180					
BdSOC1-like2	G C C G A G G T C G C C T C G T C G T C T T C C C C C G C G G G C A G G C T C T A C G A T T C G C C A G C T C C	180					
OsMADS50	G C C G A G G T C G C C T C A T C G T C T T C C C C C G C G G G C A G C T C A C G A T T C G C C A G C G C C	180					
BdSOC1-like1	G T T G A G G T C G C C T C A T C G T C T T C C C C C G C G G C C A G C T C T A C G A T T C G C C A G C G C C	180					
HvSOC1-like1	G C C G A G G T C G C C T C T C T C G T C T T C C C C C G C G G C A G G C T C A C G A T T C G C C A G C T C C	180					
	190	200	210	220	230	240	
FLC	A A R C T G S T C A A A G A T C C T T G A T C G A T A T G G S A A A C A S C A T G C T G A T G A T C T T	231					
Bradi3g51800	G C C A A A C T A A A A C A T T A G A A A G A T A C A G G G T G T A C A A T S G T C A A G A T T C A A	234					
AGL20/SOC1	A A T A T G C A A G A T A C A T A G A T C G T A T T S A G G G A T A C A A G G A T C G A G T C A C A C A A A	240					
OsMADS56	A G C T A C A G A A A C A T C G A C A G T A T A A A G C A T A C A C A A A G G A T C A T G T C A A C A A T A A G	240					
HvSOC1-like2	A G C T T G C A G A A A T C A T C G A C A G T A T A A A G C T A T A C A A A G G A T A A T G T T A A T A A A A A G	240					
BdSOC1-like2	A G C T T G C A A A A C A G A T C G A C A G T A T A A A G C A T A C A C A A A G G A T A A T G T T A A T A A A A A G	240					
OsMADS50	A G T A A C A G A A A A C A A T T G A A C G T A T A A A G C T A T A C A A A G G A A A A T A T C G G C A A C A A G	240					
BdSOC1-like1	A G C A T G C A G A A A A C A T A G A A C G T A T A A A G C A T A C A C A A G G A A A A C T A S C A G C C C A	240					
HvSOC1-like1	A G C A T G A G A A A C A G A T T G A A C G T A T A A A G A C A T C A C A A A G G A T A A T A T C A A C A G A C A G	240					
	250	260	270	280	290	300	
FLC	A A A G C C T . . . T G A T . . . C A T C A G T C A . . . A A A G C T C T G A A C T A T G C T C . . . A G A C T T	278					
Bradi3g51800	A A A G C T C . . . A C T C T . . . C T G A A A T G . . . A A G A G C T G T A C A G A A A A G T C A A A G A A A T T S	287					
AGL20/SOC1	A A A G C T T T A A G A A A T A T . . . C A G C A T T G . . . A A A T A T G A . . . S C A G C A A A A T G A T G A A G A A A T T	300					
OsMADS56	A C A T T C A C A C A A G A T A T . . . C A G C A A G T C . . . A A A G T G A . . . T A C T T T A . . . G C T T G G C A A G A A A C T T	300					
HvSOC1-like2	A C A G T A C A G C A G A T T G . . . C A G C A A G T C . . . A A A G C T G A . . . C T C T A . . . G C T T G G C A A A G A A A C T T	300					
BdSOC1-like2	A C A G T A C A A C A A G A T A T . . . C A G C A A A T C . . . A A A G C T G A . . . A C T G T A . . . G C T T G G C A A A G A A A C T T	300					
OsMADS50	A C A G T A C A G C A A G A T A T . . . A G A C A A T A . . . A A A G C T G A . . . G C T G A T G G T . . . T T G G C A A A G A A A C T T	300					
BdSOC1-like1	A C S T A C A G C A A A G A T A T . . . A G A A A A T A . . . A A A A G C T G A T . . . S C T G A G . . . G C C T T G T C A A G A A A C T T	300					
HvSOC1-like1	A C S T A C A G C A A A G A T A T . . . A G A A A A T A . . . A A A A G C T G A T . . . S C G A G . . . G C C T T G T C A A A G A A A C T T	300					
	310	320	330	340	350	360	
FLC	G A G C T A C T T G A A C T T G T G G A T A G A A G C T T G T G G G A T C A A A T G T C A A A T G T A A T G T A T C G A	337					
Bradi3g51800	G A A G C T T T A A S G G C A T C A G A G A A T T G C T T S G . . . G A B G A C C T T . . . G G A C G C T C A T S A A	347					
AGL20/SOC1	G A A C A A T G A A G T T C T A A A C G A A A C T T T T G G A . . . G A A S G C A T A . . . A C A T G C T C A T S A A	360					
OsMADS56	G A A G C T T T G A T G A T C A G A S G A A A A T A T T T G G A . . . G A A A A T T A . . . S G G A T T C T C T A T T G A	360					
HvSOC1-like2	G A A G C T T T G A A G A T C G A A A C G A A A A T C T T T G G C . . . G A A A A T T A . . . S G G A T G C T C T C T G A	360					
BdSOC1-like2	G A S C T C T T G A A C T T C . . . A A A A G A A A A C T T T T G G C . . . G A A A A C T T A . . . S G G A A T G T A C T A T T A	360					
OsMADS50	G A A G C T T T G A A C T T A C A A A A G A A A A C T T G T T G G C . . . G A A A A T T G . . . S G G A A T G T C T A T T G A	360					
BdSOC1-like1	G A A G C T T T G A A G C T A C A S A A G A A A A T T T T T G G C . . . G A A A A G T T . . . S G G A C T G T T C T T T G A	360					
HvSOC1-like1	G A T A A C T T G A A G T T G C A A A A G A A A A C T T T T G G C T C A A A A T T T . . . S G G A A T G C T C A T T G A	360					

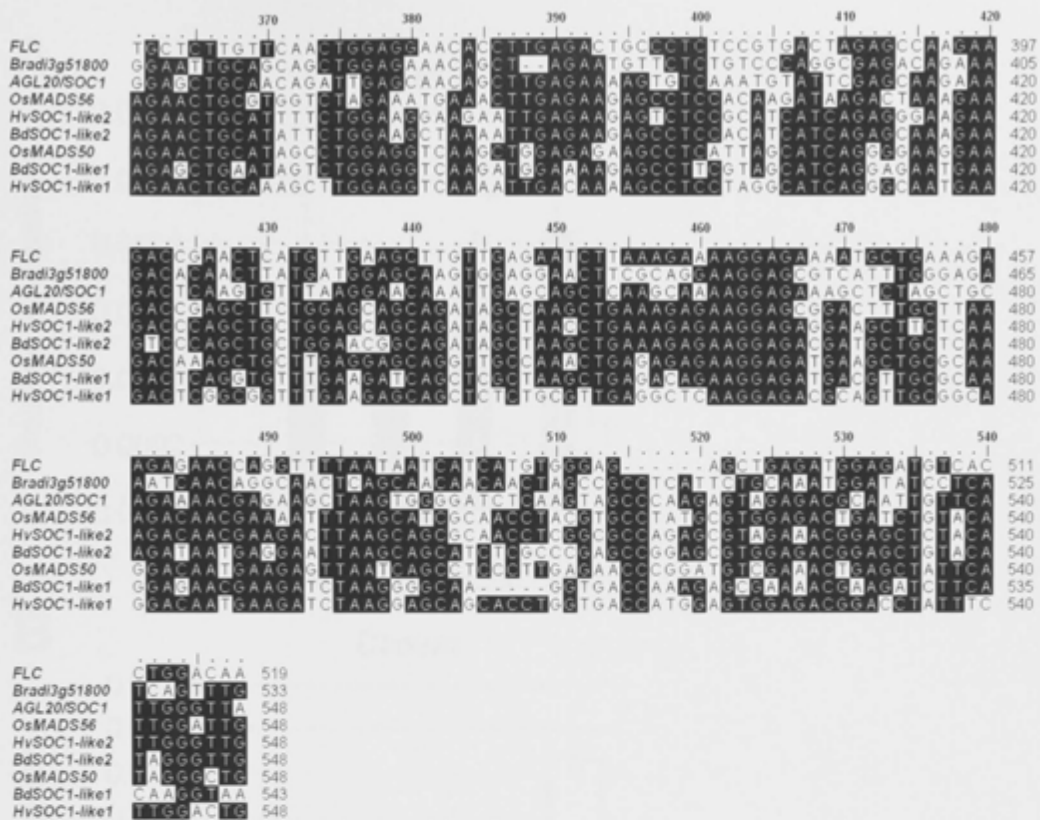

Supplemental Figure 1. Comparisons of *SOC1-like* genes

A, Diagrammatic representation of the syntentic region in rice and *Brachypodium distachyon* that contain the *SOC1-like2* genes (*OsMADS56* and *BdSOC1-like2*) and the corresponding barley Unigene numbers and map locations. Arrows indicate direction of transcription. White boxes indicate genes annotated as transposable or repeat elements. B, Alignment of nucleotide coding sequences used in constructing phylogeny (Figure 1A) of *SOC1-like* genes using *FLC* and a *Brachypodium* MADS box gene as outgroups *FLC* (NM_121052), *Bradi3g51800*, *AGL20/SOC1* (NM_130128), *OsMADS56* (AY551919), *HvSOC1-like2*, *BdSOC1-like2* (*Bradi3g32090*), *OsMADS50* (AY332476), *BdSOC1-like1* (*Bradi1g77020*) and *HvSOC1-like1*.

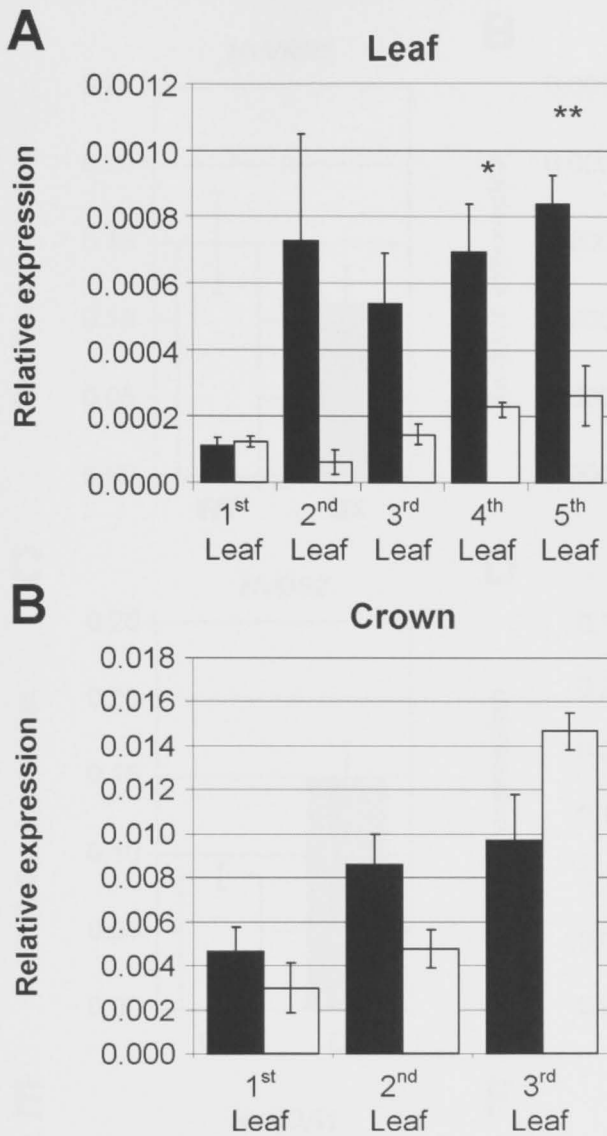

Supplemental Figure 2. Expression of *HvSOC1-like2* during development.

Relative expression levels of *HvSOC1-like2* in leaves and crown tissue from barley plants (cv. Sonja). The fully expanded leaf (A) and crown tissue (B) was taken from non-vernalized plants (black bars) and plants vernalized for 49 days (white bars) at the 2nd, 3rd, 4th, 5th and 6th leaf stage (i.e. 1st leaf taken at the 2nd leaf stage, 2nd leaf taken at 3rd leaf stage etc.). Expression is shown relative to *ACTIN*. Error bars show SE. Asterisks indicate P values of Student t-test: *, P, <0.05; **, P, <0.01 (min. of 3 biological repeats).

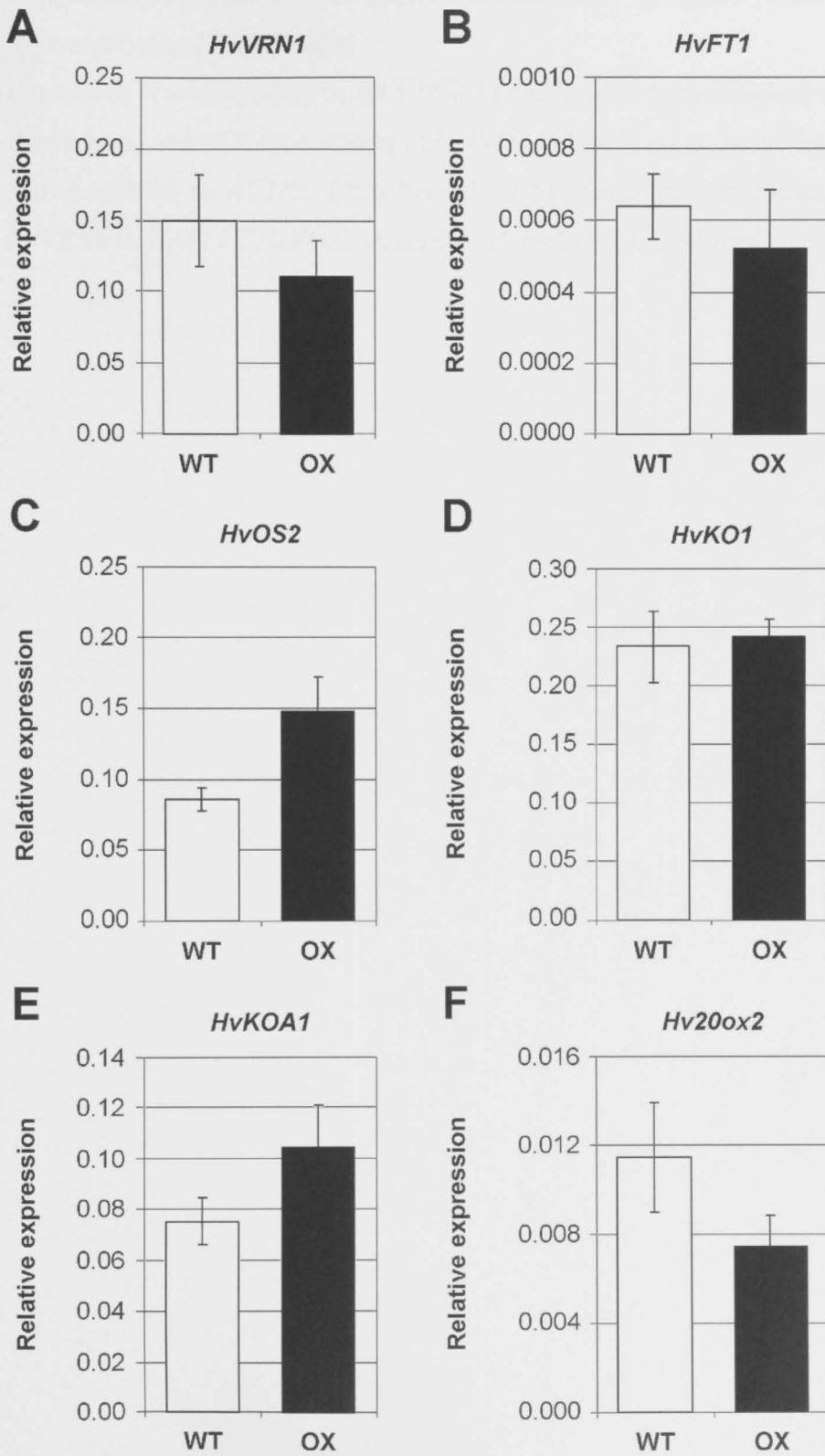

Supplemental Figure 3. Gene expression analysis of transgenic plants constitutively over-expressing *HvSOC1-like1*.

Expression was assayed by qRT-PCR in whole seedlings of transgenic plants (OX) (black bars) and wild type sibling nulls (WT) (white bars) at the 3rd leaf stage and is shown relative to *ACTIN*. Error bars show SE. (min. of 3 biological repeats). A, *HvVRN1* B, *HvFT1* C, *HVOS2* D, *HvKO1* E, *HvKOAI* F, *Hv20ox2*.

	10	20	30	40	50	60	70	80	90
<i>AP1</i>	MGRGRVQLKRIENKINRQVTF	SKRRAGLLKKAHEISVLCDAEVALVVF	SHKGGKLF	YESTDSCMEKILERYERYSYAERQL	IAPESDVNTN	90			
<i>VRN1</i>	MGRGKVQLKRIENKINRQVTF	SKRRSGLLKKAHEISVLCDAEVL	IIFSTKGGKLYEF	STESCMDKILERYERYSYAEKVLVSSSESEIQGN	90				
<i>HvSOC1-like1</i>	MVRGKTQMKRIENPTSRQVTF	SKRRGGLLKKAFELSVLCDAEVALVVF	SPRGRLYEF	FASS-SMKNITIERYKTVTKDNI	NRQTVQQDIEK	88			
<i>HvSOC1-like2</i>	MVRGKTEMKRIENATSRQVTF	SKRRNGLLKKAFELSVLCDAEVLVVF	SPRGRLYEF	FASSADSLQKSIDRYKAYTKDDVNNKTVQPD	LQQ	89			
<i>AGL20</i>	MVRGKTQMKRIENATSRQVTF	SKRRNGLLKKAFELSVLCDAEVS	IIFSPKGGKLYEF	FASS-NMQDTIDRYLRHTKDRVSTK	PKVSEENMQH	89			
	100	110	120	130	140	150	160	170	180
<i>AP1</i>	WSMEYNRLKAKIIELLERNQRHYLG	EDLQAMSPKELQNL	EQQLDTALKH	IRTRKNQLMYESINELQKKEKA	IQEQNSMLSKQIKEREKILR	180			
<i>VRN1</i>	WCHEYRKLKAKVETIQKCQKHL	MGEDLESLNLKELQQL	EQQL	ESLKHIRARKNQLMHESISELQKKEK	SLQEENKVLQKELVEKQKAQA	180			
<i>HvSOC1-like1</i>	IKADAEGLSKKLDTLEACKRKL	LGONLEECSIEELQ	SLEVKIDKSL	LGIRAMKTRRFEEQLSALRLKETQLRQDNEDLYIQ	CQKEQHLAL	178			
<i>HvSOC1-like2</i>	VKADALSLAKKLEALEDSKRK	LGENLGGCSAEELHFLEGR	IEKSLRI	IRGKKTQLLEQQIANLKEKERKLLKDNEDLRGKORNLEP	PLL	179			
<i>AGL20</i>	LKYEANMMKKIEQLEASKRKL	LGEIGTCSIEELQQIEQ	QLEKSVKCI	RARKTQVFKEQIEQLKQKEKALAAENEK	LSEKWGSHSESEVW	179			
	190	200	210	220	230	240	250		
<i>AP1</i>	AQQEQWDQQNQGHN	-MPPPLPPQHQIQHPYMLSHQSPFL	NMGGLYQEDDPMAMRNDLELTLEPVYNCNLGCF	AA	255				
<i>VRN1</i>	AQQDQTQPQT	SSSSSSFM	MRDAPPVADTSNH	PAAAGERAEDVAVQPQVPLRTALPLWMVSHING	244				
<i>HvSOC1-like1</i>	EALPAPVTMAEQCQDDAVEVETDL	FLGLPGTGRP			212				
<i>HvSOC1-like2</i>	LPPLNCVALLQPCGEPAPEQETVP	SEEDVETELYIGLPGHRC	SNRLSGQSK		230				
<i>AGL20</i>	SNKNQESTGRGDEESSPSS	EVETQLF	IGLPCSSRK		214				

Supplemental Figure 4. Comparisons of interaction motifs contained in Arabidopsis AP1, SOC1 and barley VRN1 and SOC1-like protein sequences.

Grey boxes indicate IMSS motifs. Also see Supplemental Table S1 for full description of selected motifs.

Supplemental Table 1. Subset of IMSS motifs found in Arabidopsis AP1, SOC1 and barley VRN1 and SOC1-like protein sequences

Motif number	Motif^a
1B	[ED]FXSSXXMX
3B	MXXX[IL][DE]RY
4A	XXG[KR]L[FY][ED]X
7A	XELQXXXX
8A	SXKXXXXR
9A	L[QE]XXXXXL
9B	XXXSSXXS

a) Brackets enclose alternative residues allowed at one position, X indicates wildcard (all residues allowed). As defined by van Dijk et al., 2010.

Supplemental Table 2. qRT-PCR primers

Gene name	Accession number	Forward	Reverse
<i>HvSOC1-like1</i>	-	CTGATGCCGAGGGCTTGTC	GCAACTGCGTCTCCTTGAGC
<i>HvSOC1-like2</i>	-	GAGCAGGAGACGGTACCAAG	TCCGGCTGGTTAGCTATTTG
<i>HvFT3</i>	AB476614	TGGTTGTGGCTCATGTTATGC	GTCACTGCCACCGAAATCAA
<i>ent-kaurene synthase-like</i>	AY551437	AGGTGGAATGGAGAACGAGCGG	GAGAGACGCTGTTCAGTTTACCC
<i>HvKO1*</i>	AY551434	GCAGGTTTGGTTCGGTAATG	TAACCAAGGACAGGCGAACT
<i>HvKO1*</i>	AF326277	AAAATCCTAGACCGCGTCG	ACTCATCCGCGACAACAAC
<i>Hv20ox2*</i>	Unpublished sequence	GCCTTCACCCAGTGGTTCT	AGCCAGCGTCCAAAAATG

* Primers donated by Dr. Peter Chandler

Chapter 5

General discussion and conclusions

“We owe most of our great inventions and most of the achievements of genius to idleness...either enforced or voluntary. The human mind prefers to be spoon-fed with the thoughts of others, but deprived of such nourishment it will, reluctantly, begin to think for itself and such thinking, remember, is original thinking and may have valuable results.”

Dame Agatha Christie

***VRNI* and the vernalization response**

The main objective of this thesis was to investigate the molecular mechanisms underlying the vernalization response in temperate cereals. Consistent with previous studies, *VRNI* was identified amongst only a small number of genes that show a sustained response to prolonged cold (**Chapter 2**; Trevaskis et al., 2006; Sasani et al., 2009). These findings combined with recent studies on the vernalization response suggest that *VRNI* is central to this response and acts to promote flowering in temperate cereals by regulating the activity of other genes after winter (**Chapter 3**; Trevaskis et al., 2006; Distelfeld et al., 2009; Sasani et al., 2009). Therefore, understanding how *VRNI* itself is regulated by cold is important to understanding how prolonged cold induces flowering in temperate cereals.

Since the commencement of this thesis there have been significant advances in the understanding of how *VRNI* is regulated. Two general mechanisms are thought to control the transcriptional activity of *VRNI*; a repressive mechanism that determines the requirement for vernalization and a cold-dependant mechanism that results in the activation of *VRNI* during exposure to cold (reviewed by Trevaskis, 2010). Regions within the first intron of *VRNI* are important for the repression of *VRNI* prior to winter; with deletions and insertions in this region resulting in higher expression without cold treatment (von Zitzewitz et al., 2005; Cockram et al., 2007; Szűcs et al., 2007; Hemming et al., 2009). As is discussed in **Chapter 1** of this thesis the mechanism controlling the repression of *VRNI* has some similarities to the regulation of the MADS box gene *FLOWERING LOCUS C (FLC)* from *Arabidopsis* and may be related to changes in chromatin state (Sheldon et al., 2002; Wood et al., 2006; De Lucia et al., 2008; Oliver et al., 2009). The mechanisms controlling the activation of *VRNI* in response to cold are less clear. Initially it was proposed that activation of *VRNI* was mediated through the vernalization induced repression of *TaVRT2* (Kane et al., 2005; Kane et al., 2007). Subsequent work has shown that this is probably not the case. The expression *VRT2* appears to be induced by cold, not repressed (Trevaskis et al., 2007; Pidal et al., 2009). Furthermore, the region of the *VRNI* promoter thought to mediate this response is not required for the cold induction of *VRNI* (Pidal et al., 2009). The key question of how *VRNI* is regulated by cold remains unanswered. This question is part of a broader research theme in plant biology that is investigating how plants perceive cold and the signalling mechanisms that regulate downstream processes such as vernalization. Understanding these processes could not only assist

in our understanding of the vernalization response but could also help in our understanding of other processes such as cold acclimation and freezing tolerance. Work carried out in this thesis has started to address this question with a number of transcription factors identified as being regulated by cold in different ways (**Chapter 2**). But this work is only in its infancy and the importance of these findings for the vernalization response is not yet known.

In addition to understanding how *VRN1* is regulated, another key question is how does *VRN1* promote flowering; *i.e.* what genes does it regulate? A major target of *VRN1* is *VERNALIZATION2 (VRN2)* (reviewed by Trevaskis et al., 2006 and Distelfeld et al., 2009). *VRN2* is regulated by daylength and represses flowering when plants are grown in long days by inhibiting the expression of *FLOWERING LOCUS T (FT)* (Trevaskis et al., 2006; Hemming et al., 2008; Distelfeld et al., 2009; Sasani et al., 2009). After plants are vernalized *VRN1* represses *VRN2* which results in higher expression of *FT* (Trevaskis et al., 2006; Hemming et al., 2008; Distelfeld et al., 2009; Sasani et al., 2009). It is unclear if *VRN1* regulates the activity of *VRN2* directly or involves other intermediate steps that are yet to be identified.

Other potential regulatory targets of *VRN1* were identified in this thesis, including *ODDSOC2 (OS2)* (**Chapter 2** and **3**). *OS2* is a grass specific MADS box gene that is repressed by cold and *VRN1* (**Chapter 3**). Expression analysis revealed that *OS2* is down-regulated by cold independently of *VRN1* (**Chapter 3**). But the repression of *OS2* after plants were returned to normal growing conditions required *VRN1* (**Chapter 3**). Overexpression of *OS2* in barley delayed flowering and caused dwarfing (**Chapter 3**). The mechanism underlying these phenotypes could be attributed to the down-regulation of a number of *FLOWERING PROMOTING FACTOR1 (FPF1)*-like genes. In *Arabidopsis* *FPF1* is thought to promote flowering and elongation downstream of *FT* as part of a daylength flowering response pathway in that operates in diverse plant species (Kania et al., 1997; Melzer et al., 1999; Smykal et al., 2004). The down-regulation of *OS2* likely contributes to the acceleration of flowering through the de-repression and subsequent activation of *FPF1*-like genes in spring (**Chapter 3**). These findings extend our understanding of the vernalization response in temperate cereals and further highlight the differences between the vernalization response of temperate cereals and *Arabidopsis*.

Implications for future research

The findings in this thesis present new questions and areas of research that should be continued in order to gain a better understanding of the developmental biology of temperate cereals. In **Chapter 2**, *VRNI* was identified as one of only a small number of genes that exhibit a sustained response to prolonged cold. These findings support the hypothesis that *VRNI* is central to the vernalization response in temperate cereals and indicates that *VRNI* is probably regulating many of the processes that underlie vernalization induced flowering. Therefore understanding how *VRNI* is regulated and identifying what genes *VRNI* regulates are two key questions that should be addressed in order to gain a greater understanding of seasonal flowering responses in temperate cereals.

How is *VRNI* regulated?

Regions of the *VRNI* gene that are important for its regulation have already been identified and include a regions within the first intron as well as regions of the promoter (Yan et al., 2004; Fu et al., 2005; von Zitezewitz et al., 2005; Cockram et al., 2007; Szücs et al., 2007; Li and Dubcovsky 2008; Hemming et al., 2009). Understanding how repression of *VRNI* is mediated through the first intron could be achieved by employing methods that have already been used successfully in *Arabidopsis* to study the regulation of *FLC* (reviewed by He 2009). Similarly, the identification of regions that are important for cold induction of *VRNI* could be achieved by employing methods used to identify such regions in other cold regulated genes (reviewed in Papdi et al., 2009; Yamaguchi-Shinozaki and Shinozaki, 2005). One such approach is the use of reporter genes that have step wise deletions of different sections of the promoter. This could not only lead to the discovery of regions that are important for cold regulation of *VRNI*, but also enable the identification of the type of transcription factor involved in regulating *VRNI*. By analysing the sequence of regulatory regions any conserved transcription factor binding sites could easily be identified. This information could be useful in selecting candidate genes from lists of cold responsive transcription factors, like those identified in this thesis (**Chapter 2**).

***VRNI* regulatory targets**

Identifying genes directly regulated by *VRNI* is also important to further our understanding of how vernalization triggers flowering in temperate cereals. This could

be achieved through the use of antibodies that are specific to VRN1 or by epitope-tagging; where VRN1 is tagged with a protein that is easily recognised by antibodies. Then the regions of DNA that VRN1 binds to could be isolated through the use of immunoprecipitation and sequenced. This technology has already been used in a number of studies in the model plant Arabidopsis and has helped identify and understand the role of other MADS box genes in that plant (Kaufmann et al., 2009; Kaufmann et al., 2010). The identification of genes that are directly regulated by VRN1 will eventually lead to a more detailed understanding of how flowering behaviour influences other aspects of development. In turn a better understanding of the biology behind flowering behaviour could potentially lead to novel solutions for complex problems. For example, the initiation of floral development is associated with a decrease in tolerance to low temperatures (Fowler et al., 1996; Mahfoozi et al., 2001). These observations suggest that activation of *VRN1* and / or *FT* somehow shuts off regulatory pathways that are important for the plants ability to withstand freezing temperatures (Fowler et al., 2001; Limin and Fowler, 2006; Stockinger et al., 2007; Dhillon et al., 2010). By understanding how *VRN1* is involved in this process any regulatory interactions that exist between the two pathways could potentially be manipulated to uncouple the interaction. This could potentially enable the development of barley and wheat varieties that are more tolerant to freezing temperatures irrespective of their growth phase (Chen et al., 2009).

Beyond *VRN1*: the importance of genes other than *VRN1*

Several regulatory targets of *VRN1* have been identified in this thesis, including *OS2* and *RNase-S-like* genes (**Chapter 2** and **3**). Further characterization of these candidates and genes such as the *FPP1-like* genes is required to understand more about their biochemical function and any potential roles in regulating flowering responses in temperate cereals (**Chapter 3**). The characterisation of loss of function mutants and screening for existing natural variation for these genes would be invaluable in furthering our understanding of the role they play in seasonal flowering responses. Although *HvSOC1-like* genes are not regulated by vernalization similar approaches would also be useful in determining what role these genes play in flowering responses (**Chapter 4**).

Carrying out further analysis on genes identified as showing a maintained response to prolonged cold would also be useful to determine if and what role they

play in the vernalization response in temperate cereals. For instance, a gene encoding for a calcium binding EF-hand protein was identified amongst candidates that showed increased expression in response to prolonged cold (**Chapter 2**). Calcium signalling might be important for short term cold responses but its role in long term cold responses is less clear (Knight et al., 1996; Doherty et al., 2009). Gene expression analysis in the *VRN1* deletion mutant revealed that the expression of this gene was higher in the deletion mutant versus wild-type seedlings after seven weeks of growth in the dark at 4°C (data not shown). The identification and subsequent gene expression analysis of this gene suggests that vernalization has a lasting effect on calcium signalling. The importance of this finding is unclear but further characterisation could reveal what role calcium signalling has in the vernalization response of temperate cereals.

Another closely related area of research involves investigating the role of *VRN2-like* genes in the regulation of photoperiod responses in cereals (**Chapter 1**). *VRN2* and the *VRN2-like* gene, *Ghd7*, repress flowering in wheat, barley and rice (Yan et al., 2004; Dubcovsky et al., 2006; Trevaskis et al., 2006; Xue et al., 2008). Recent work in rice has identified a HAP factor that potentially interacts with GHD7 and the CONSTANS-like protein HD1 to regulate flowering in response to photoperiod (Wei et al., 2010; Yan et al., 2010). Although much is known about how HAP factors control photoperiod responses in Arabidopsis, very little is about the interaction of *VRN2-like* proteins and HAP factors in grasses (Kumimoto et al., 2010). Future research in this area is likely to focus on the identification of HAP factors that are involved in mediating different flowering responses. Research in this area has the potential to generate plants with novel flowering behaviours that might be better suited to certain growing conditions, compared to current varieties.

Concluding remarks

Emerging genetic resources and the future of cereal biology

Many of the experiments outlined above would benefit from the availability of an assembled genome sequence and other genetic resources such as reverse genetics platforms. A recent report from the International Barley Sequencing Consortium suggests that a draft genome sequence for barley will be complete by the end of 2011 (Muehlbauer et al., 2011). While groups involved in the sequencing and assembly of the wheat genome are faced with more difficult challenges (*i.e.* added complexity

associated with the assembly of polyploid genomes), the International Wheat Genome Sequencing Consortium has been established to coordinate efforts in this area.

The availability of an assembled and annotated genome sequence has already accelerated research efforts in a number of different plant species and includes *Arabidopsis*, rice, *Sorghum bicolor* and *Medicago truncatula*. The release of a genome sequence is almost always followed an acceleration in the generation of new genetic resources and inevitably results in an overall increase research capability for that plant species (Buell and Sundaesan, 2003; Droc et al., 2005; Cross et al., 2006; Tadege et al., 2009; Koornneef and Meinke, 2010). Based on these observations it would not be unreasonable to predict that a similar trend will follow after the release of assembled sequences for barley and wheat. The generation of such resources in wheat and barley should result in an acceleration of our understanding of many aspects of cereal biology, including areas like the vernalization response.

Emerging sequencing technologies will also accelerate research efforts in cereal crop species with studies in rice and sorghum already exploiting this technology (Huang et al., 2010; Lam et al., 2010). The increasing affordability of resequencing of genomes will aid breeding and research programs in a number of different ways. For example, resequencing of breeding lines for use in association studies will greatly increase marker coverage and therefore the power of such studies. Discovering novel alleles of genes will also be made easier as lines of interest could simply be resequenced. This would enable further utilization of already existing resources such as the vast collections of land races and wild-relatives that exist for barley and wheat and would result in an expansion of our understanding in a number of areas of biological research.

Concluding remarks

In conclusion, the research undertaken in this thesis has extended the understanding of seasonal flowering responses in temperate cereals. Rapid advances in cereal genomics combined with advances in sequencing technologies sets the scene for an exciting and dramatic acceleration in our understanding of biological processes in barley and wheat.

Literature cited

- Buell CR, Sundaesan V** (2003) A Workshop on Establishing a Rice Resource Center in the United States. *Plant Physiology* **132**: 1137
- Chen A, Gusta LV, Brule-Babel A, Leach R, Baumann U, Fincher GB, Collins NC** (2009) Varietal and chromosome 2H locus-specific frost tolerance in reproductive tissues of barley (*Hordeum vulgare L.*) detected using a frost simulation chamber. *Theoretical and Applied Genetics* **119**: 685-694
- Chouard P** (1960) Vernalization and its Relations to Dormancy. *Annual Review of Plant Physiology* **11**: 191-238
- Cockram J, Chiapparino E, Taylor S, Stamati K, Donini P, Laurie D, O'Sullivan D** (2007) Haplotype analysis of vernalization loci in European barley germplasm reveals novel *VRN-H1* alleles and a predominant winter *VRN-H1/VRN-H2* multi-locus haplotype. *Theoretical and Applied Genetics* **115**: 993-1001
- Cross M, Lee L, Rice R, Henry R** (2006) Targeted mutagenesis in sorghum using an improved high-throughput screening platform – a reverse genetics strategy to complement the sorghum genomics effort. *In Plant and Animal Genomes Conference XIV*, San Diego, CA
- De Lucia F, Crevillen P, Jones AME, Greb T, Dean C** (2008) A PHD-Polycomb Repressive Complex 2 triggers the epigenetic silencing of *FLC* during vernalization. *Proceedings of the National Academy of Sciences of the United States of America* **105**: 16831-16836
- Dhillon T, Pearce SP, Stockinger EJ, Distelfeld A, Li CX, Knox AK, Vashegyi I, Vagujfalvi A, Galiba G, Dubcovsky J** (2010) Regulation of Freezing Tolerance and Flowering in Temperate Cereals: The *VRN-1* Connection. *Plant Physiology* **153**: 1846-1858
- Distelfeld A, Li C, Dubcovsky J** (2009) Regulation of flowering in temperate cereals. *Current Opinion in Plant Biology* **12**: 178-184
- Doherty CJ, Van Buskirk HA, Myers SJ, Thomashow MF** (2009) Roles for Arabidopsis CAMTA Transcription Factors in Cold-Regulated Gene Expression and Freezing Tolerance. *Plant Cell* **21**: 972-984
- Droc G, Ruiz M, Larmande P, Pereira A, Piffanelli P, Morel JB, Dievart A, Courtois B, Guiderdoni E, Perin C** (2005) OryGenesDB: a database for rice reverse genetics. *Nucleic Acids Research* **34**: D736-D740

- Dubcovsky J, Loukoianov A, Fu D, Valarik M, Sanchez A, Yan L** (2006) Effect of Photoperiod on the Regulation of Wheat Vernalization Genes *VRN1* and *VRN2*. *Plant Molecular Biology* **60**: 469-480
- Fowler DB, Breton G, Limin AE, Mahfoofi S, Sarhan F** (2001) Photoperiod and Temperature Interactions Regulate Low-Temperature-Induced Gene Expression in Barley. *Plant Physiology* **127**: 1676-1681
- Fowler DB, Limin AE, Wang SY, Ward RW** (1996) Relationship between low-temperature tolerance and vernalization response in wheat and rye. *Canadian Journal of Plant Science* **76**: 37-42
- Fu DL, Szucs P, Yan LL, Helguera M, Skinner JS, von Zitzewitz J, Hayes PM, Dubcovsky J** (2005) Large deletions within the first intron in *VRN-1* are associated with spring growth habit in barley and wheat. *Molecular Genetics and Genomics* **273**: 54-65
- He YH** (2009) Control of the Transition to Flowering by Chromatin Modifications. *Molecular Plant* **2**: 554-564
- Hemming M, Fieg S, James Peacock W, Dennis E, Trevaskis B** (2009) Regions associated with repression of the barley (*Hordeum vulgare*) *VERNALIZATION1* gene are not required for cold induction. *Molecular Genetics and Genomics* **282**: 107-117
- Hemming MN, Peacock WJ, Dennis ES, Trevaskis B** (2008) Low-temperature and daylength cues are integrated to regulate *FLOWERING LOCUS T* in barley. *Plant Physiology* **147**: 355-366
- Huang X, Wei X, Sang T, Zhao Q, Feng Q, Zhao Y, Li C, Zhu C, Lu T, Zhang Z, Li M, Fan D, Guo Y, Wang A, Wang L, Deng L, Li W, Lu Y, Weng Q, Liu K, Huang T, Zhou T, Jing Y, Li W, Lin Z, Buckler ES, Qian Q, Zhang Q-F, Li J, Han B** (2010) Genome-wide association studies of 14 agronomic traits in rice landraces. *Nature Genetics* **42**: 961-967
- Kane NA, Agharbaoui Z, Diallo AO, Adam H, Tominaga Y, Ouellet F, Sarhan F** (2007) *TaVRT2* represses transcription of the wheat vernalization gene *TaVRN1*. *The Plant Journal* **51**: 670-680
- Kane NA, Danyluk J, Tardif G, Ouellet F, Laliberte J-F, Limin AE, Fowler DB, Sarhan F** (2005) *TaVRT-2*, a Member of the *StMADS-11* Clade of Flowering Repressors, Is Regulated by Vernalization and Photoperiod in Wheat. *Plant Physiology* **138**: 2354-2363

- Kania T, Russenberger D, Peng S, Apel K, Melzer S (1997)** *FPF1* Promotes Flowering in Arabidopsis. *Plant Cell* **9**: 1327-1338
- Kaufmann K, Muino JM, Jauregui R, Airoidi CA, Smaczniak C, Krajewski P, Angenent GC (2009)** Target genes of the MADS transcription factor *SEPALLATA3*: integration of developmental and hormonal pathways in the Arabidopsis flower. *PLoS Biol* **7**: e1000090
- Kaufmann K, Wellmer F, Muino JM, Ferrier T, Wuest SE, Kumar V, Serrano-Mislata A, Madueno F, Krajewski P, Meyerowitz EM, Angenent GC, Riechmann JL (2010)** Orchestration of Floral Initiation by *APETALA1*. *Science* **328**: 85-89
- Knight H, Trewavas AJ, Knight MR (1996)** Cold Calcium Signaling in Arabidopsis Involves Two Cellular Pools and a Change in Calcium Signature after Acclimation. *Plant Cell* **8**: 489-503
- Koornneef M, Meinke D (2010)** The development of Arabidopsis as a model plant. *The Plant Journal* **61**: 909-921
- Kumimoto RW, Zhang Y, Siefers N, Holt BF (2010)** NF-YC3, NF-YC4 and NF-YC9 are required for CONSTANS-mediated, photoperiod-dependent flowering in Arabidopsis thaliana. *The Plant Journal* **63**: 379-391
- Lam HM, Xu X, Liu X, Chen WB, Yang GH, Wong FL, Li MW, He WM, Qin N, Wang B, Li J, Jian M, Wang JA, Shao GH, Wang J, Sun SSM, Zhang GY (2010)** Resequencing of 31 wild and cultivated soybean genomes identifies patterns of genetic diversity and selection. *Nature Genetics* **42**: 1053-U1041
- Li CX, Dubcovsky J (2008)** Wheat FT protein regulates *VRN1* transcription through interactions with FDL2. *Plant Journal* **55**: 543-554
- Limin AE, Fowler DB (2006)** Low-temperature tolerance and genetic potential in wheat (*Triticum aestivum* L.): response to photoperiod, vernalization and plant development. *Planta* **224**: 360 - 366
- Mahfoozi S, Limin AE, Fowler DB (2001)** Developmental regulation of low-temperature tolerance in winter wheat. *Annals of Botany* **87**: 751-757
- Melzer S, Kampmann G, Chandler J, Apel K (1999)** *FPF1* modulates the competence to flowering in *Arabidopsis*. *The Plant Journal* **18**: 395-405
- Mikkelsen MD, Thomashow MF (2009)** A role for circadian evening elements in cold-regulated gene expression in Arabidopsis. *The Plant Journal* **60**: 328-339

- Muehlbauer G, Close T, Graner A, Langridge P, Li C, Matsumoto T, Sato K, Schulman A, Waugh R, Wise R, Zhang G, Stein N** (2011) A Sequence Of The Barley Genome In 2011. *In Plant & Animal Genomes XIX Conference*, San Diego, CA
- Oliver SN, Finnegan EJ, Dennis ES, Peacock WJ, Trevaskis B** (2009) Vernalization-induced flowering in cereals is associated with changes in histone methylation at the *VERNALIZATION1* gene. *Proceedings of the National Academy of Sciences of the United States of America* **106**: 8386-8391
- Papdi C, Joseph MP, Salamo IP, Vidal S, Szabados L** (2009) Genetic technologies for the identification of plant genes controlling environmental stress responses. *Functional Plant Biology* **36**: 696-720
- Pidal Br, Yan L, Fu D, Zhang F, Tranquilli G, Dubcovsky J** (2009) The CArG-Box Located Upstream from the Transcriptional Start of Wheat Vernalization Gene *VRN1* Is Not Necessary for the Vernalization Response. *Journal of Heredity* **100**: 355-364
- Pugsley AT** (1971) Genetic analysis of Spring-Winter Habit of Growth in Wheat. *Australian Journal of Agricultural Research* **22**: 21-31
- Sasani S, Hemming MN, Oliver SN, Greenup A, Tavakkol-Afshari R, Mahfoozi S, Poustini K, Sharifi H-R, Dennis ES, Peacock WJ, Trevaskis B** (2009) The influence of vernalization and daylength on expression of flowering-time genes in the shoot apex and leaves of barley (*Hordeum vulgare*). *Journal of Experimental Botany* **60**: 2169-2178
- Sheldon CC, Conn AB, Dennis ES, Peacock WJ** (2002) Different Regulatory Regions Are Required for the Vernalization-Induced Repression of *FLOWERING LOCUS C* and for the Epigenetic Maintenance of Repression. *Plant Cell* **14**: 2527-2537
- Shitsukawa N, Ikari C, Shimada S, Kitagawa S, SakaMoto K, Saito H, Ryuto H, Fukunishi N, Abe T, Takumi S, Nasuda S, Murai K** (2007) The einkorn wheat (*Triticum monococcum*) mutant, maintained vegetative phase, is caused by a deletion in the *VRN1* gene. *Genes & Genetic Systems* **82**: 167-170
- Smykal P, Gleissner R, Corbesier L, Apel K, Melzer S** (2004) Modulation of flowering responses in different *Nicotiana* varieties. *Plant Molecular Biology* **55**: 253-262

- Stockinger EJ, Skinner JS, Gardner KG, Francia E, Pecchioni N** (2007) Expression levels of barley *CBF* genes at the *Frost resistance-H2* locus are dependent upon alleles at *Fr-H1* and *Fr-H2*. *The Plant Journal* **51**: 308-321
- Szűcs P, Skinner J, Karsai I, Cuesta-Marcos A, Haggard K, Corey A, Chen T, Hayes P** (2007) Validation of the *VRN-H2 / VRN-H1* epistatic model in barley reveals that intron length variation in *VRN-H1* may account for a continuum of vernalization sensitivity. *Molecular Genetics and Genomics* **277**: 249-261
- Tadege M, Wang TL, Wen J, Ratet P, Mysore KS** (2009) Mutagenesis and Beyond! Tools for Understanding Legume Biology. *Plant Physiology* **151**: 978-984
- Takahashi R, Yasuda S** (1971) Genetics of earliness and growth habit in barley. In RA Nilan, ed, *Barley Genetics II* (Proceedings of the Second International Barley Genetics Symposium). Washington State University Press, pp 388-408
- Trevaskis B** (2010) The central role of the *VERNALIZATION1* gene in the vernalization response of cereals. *Functional Plant Biology* **37**: 479-487
- Trevaskis B, Hemming MN, Peacock WJ, Dennis ES** (2006) *HvVRN2* Responds to Daylength, whereas *HvVRN1* Is Regulated by Vernalization and Developmental Status. *Plant Physiology* **140**: 1397-1405
- Trevaskis B, Tadege M, Hemming MN, Peacock WJ, Dennis ES, Sheldon C** (2007) *Short Vegetative Phase-like* MADS-box genes inhibit floral meristem identity in barley. *Plant Physiology* **143**: 225-235
- von Zitzewitz J, Szucs P, Dubcovsky J, Yan LL, Francia E, Pecchioni N, Casas A, Chen THH, Hayes PM, Skinner JS** (2005) Molecular and structural characterization of barley vernalization genes. *Plant Molecular Biology* **59**: 449-467
- Wei X, Xu J, Guo H, Jiang L, Chen S, Yu C, Zhou Z, Hu P, Zhai H, Wan J** (2010) *DTH8* Suppresses Flowering in Rice, Influencing Plant Height and Yield Potential Simultaneously. *Plant Physiology* **153**: 1747-1758
- Wood CC, Robertson M, Tanner G, Peacock WJ, Dennis ES, Helliwell CA** (2006) The *Arabidopsis thaliana* vernalization response requires a polycomb-like protein complex that also includes *VERNALIZATION INSENSITIVE 3*. *Proceedings of the National Academy of Sciences of the United States of America* **103**: 14631-14636

- Xue W, Xing Y, Weng X, Zhao Y, Tang W, Wang L, Zhou H, Yu S, Xu C, Li X, Zhang Q** (2008) Natural variation in *Ghd7* is an important regulator of heading date and yield potential in rice. *Nature Genetics* **40**: 761-767
- Yamaguchi-Shinozaki K, Shinozaki K** (2005) Organization of cis-acting regulatory elements in osmotic- and cold-stress-responsive promoters. *Trends in Plant Science* **10**: 88-94
- Yan L, Helguera M, Kato K, Fukuyama S, Sherman J, Dubcovsky J** (2004) Allelic variation at the *VRN-1* promoter region in polyploid wheat. *Theoretical and Applied Genetics* **109**: 1677-1686
- Yan L, Loukoianov A, Blechl A, Tranquilli G, Ramakrishna W, SanMiguel P, Bennetzen JL, Echenique V, Dubcovsky J** (2004) The Wheat *VRN2* Gene Is a Flowering Repressor Down-Regulated by Vernalization. *Science* **303**: 1640-1644
- Yan W-H, Wang P, Chen H-X, Zhou H-J, Li Q-P, Wang C-R, Ding Z-H, Zhang Y-S, Yu S-B, Xing Y-Z, Zhang Q-F** (2010) A Major QTL, *Ghd8*, Plays Pleiotropic Roles in Regulating Grain Productivity, Plant Height, and Heading Date in Rice. *Molecular Plant*