

Development of non-marking tubular holding equipment

B.V. Kopey*, M.M. Liakh, Yu.M. Liakh, V.V. Mykhailiuk

Ivano-Frankivsk National Technical University of Oil and Gas;
15, Karpatska Str., Ivano-Frankivsk, 76019, Ukraine

Received: 16.06.2017 Accepted: 14.07.2017

Abstract

The article gives the recommendations of a technical solution for preventing the destruction of external surfaces of drill and casing pipes by wedge grippers in the process of performing descending-lifting operations. Also, a constructive solution to clamping the surface of the pipes during screwing or unscrewing of thread connections is proposed. The research of proposed technical solutions of grippers using computer models has been carried out. The main parameters of the design elements of the proposed wedge gripper and clamp are established, which can provide the technological process without destroying the outer surfaces of the pipes of the oil assortment.

Keywords: *non-marking equipment, pipe, thread connection, tripping operations, wedge gripper.*

1. The whole complex of operations that is related to the tripping operations and processes of the threaded connections break-out/make-up can be divided into two classes:

1.1 Lowering in the hole of drilling, tubing and casing columns.

The external surfaces of pipe columns are relatively clean and dry in this case, that is why it is considerably easier to introduce new devices in practice.

1.2 Lifting up the drilling and tubing column from the hole.

The external surface of drilling column will be covered by mud. This mud has special characteristics that can negatively influence the contact of clamp with the surface of pipe. This also must be taken into account and we have to find ways of rapid and simple cleaning of pipes surface from mud.

2. The devices can be divided into several categories based on the mechanisms of action:

2.1 To hold the outer surface of one pipe for torque transmitting at make-up/break-out of the threaded connections, the value of moments is relatively small (100-500 Nm);

2.2. To grab part of the surface of the other pipe for torque transmitting at make-up/break-out of the threaded connections there is a large torque value in the range of 800–3000 Nm;

2.3 To grab a considerably longer part of the pipe surface than the ones used in p.p. 2.1, 2.2 for holding individual pipes (relatively lightweight), and also heavy weight string assemblies (1500 kN and more).

Wedge grippers supporting drill and casing columns, and individual tubes have been developed.

Gripping wedge 2 is equipped with elastic (rubber) reinforced insert 3, the surface of insert 3 is in contact with tube 1 and has a surface protector, similar to the vehicle's tires, ensuring a good connection (Fig. 1).

A protector on the surface of elastic insert assists in cleaning the contacting surface of pipe from the dirt and mud.

Rear contact surface 4 of wedge 2 contacts body 6 and moves under the weight of the pipe or string, creating pressure through the intermediate elastic plates 3 on the surface of pipe 1. Stop 5 on wedge 2 limits the elongation of an elastic insert and insures holding of drill (casing) column using the offered device. Shear stresses in elastic plates are in admissible values as finite elements method (FEM) indicates. The coefficient of friction between the wedge and the body doesn't considerably influence upon the compressive pressure in the gripping process. Wedge grippers may be fixed in slots of the spider housing.

Fig. 2 presents two main positions of wedge gripper, respectively:

- opened spider (Fig. 2, a), when the pipe string moves up or down;

- operating position (Fig. 2, b), when the column is held in suspended state. The whole force of dies clamping to the pipe body 7 is transmitted through contact elastic elements 5. Axial loads G from the weight of the column 7 are supported by contact elastic elements 5 and transferred to housing shelves 6. The area of contact may be determined based on the calculating scheme (Fig. 2, c), and variants are shown in Fig. 3.

The options of contact surface are shown in Fig. 3. It is necessary to notice that the option, shown in Fig. 3, a, is preferred for its simplicity, while options b and d (Fig. 3) have the best strength, and the option c (Fig. 3) has the highest strength and smoothed corners.

* Corresponding author:
kopeyb@ukr.net

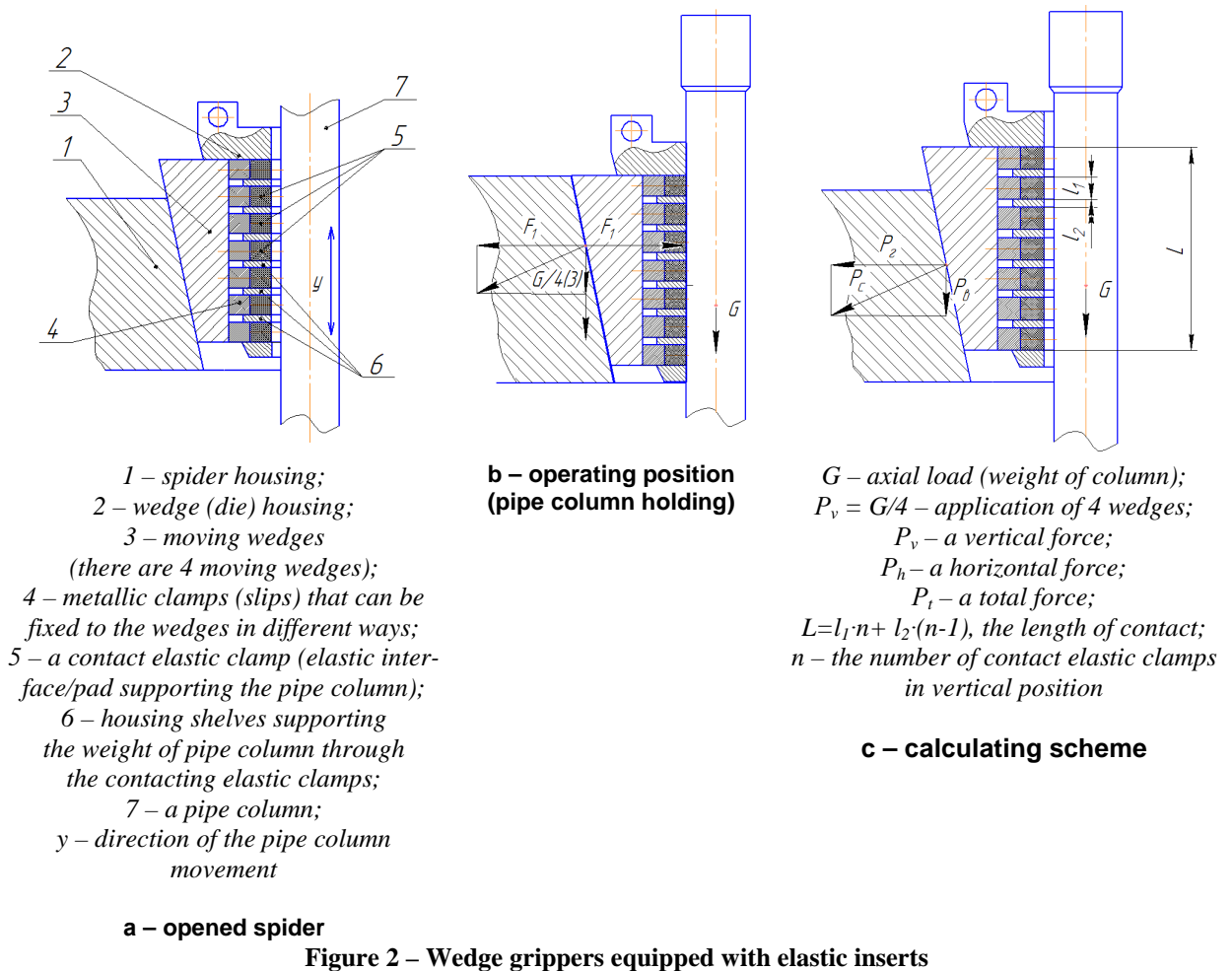
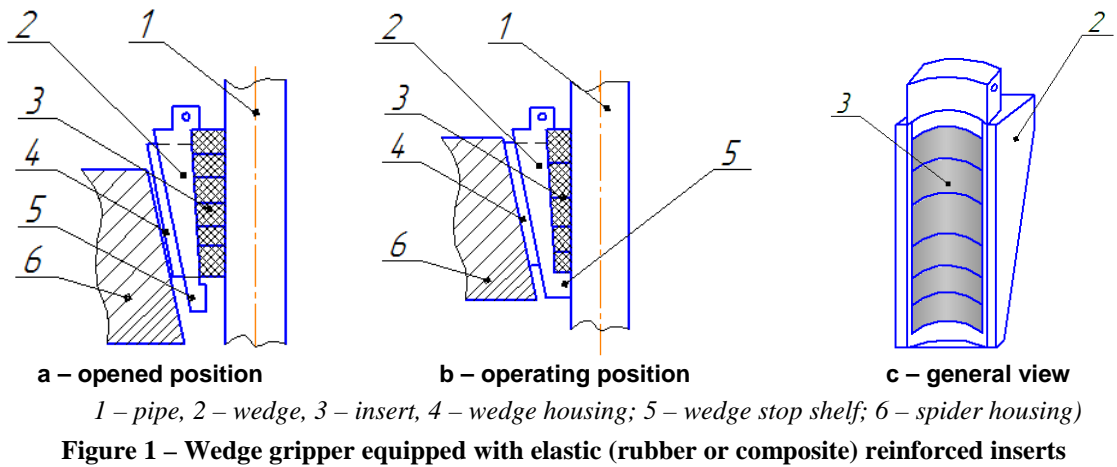

When considering all options, it is necessary to examine and take into account the static situations between contacting surfaces when they do not move in relation to each other. In these cases the friction coefficient is also different. This factor must be necessarily taken into account in the process of designing the devices. Metal composite or cermet friction inserts can ensure higher shear strength (60–100 MPa) and suitable coefficient of friction instead of elastic clamp.

According to Figures 2 a and 3 a the value of l_1 (thickness or height of polyurethane segments) is within the range of 40–60 mm (these values can be adjusted

during experimental research to choose the optimal values). This value is determined taking into account mechanical properties of elastic contacting clamp holders of the column tube.

The value l_2 is determined taking into account the strength characteristics of the metal of housing shelves (slots), which support the weight of the pipe string through the contacting elastic clamps (interface pads).

The total length l (or height for the set of housing clamps with shelves) is also determined taking into account the maximum weight of the column of pipes and their diameter. It is necessary to determine the

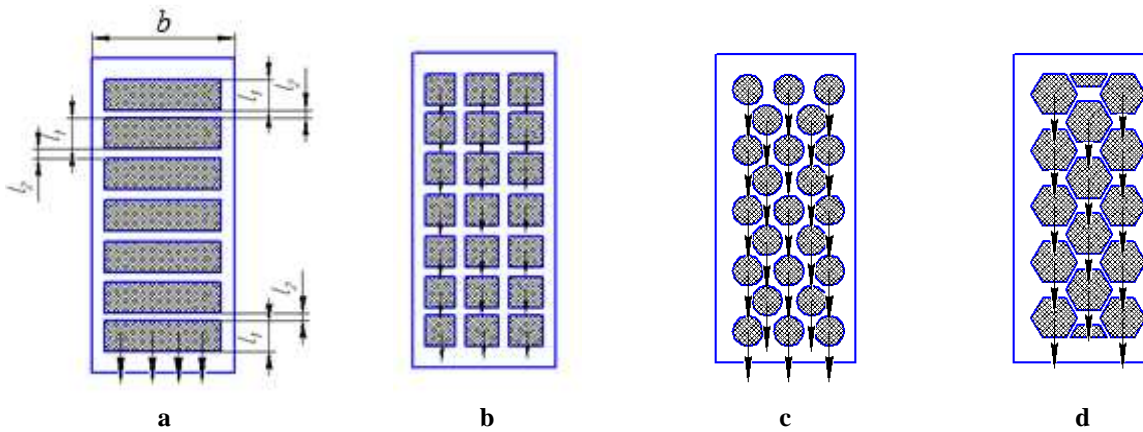

Elastic working elements: a – rectangular; b – square; c – round; d – hexagonal

Figure 3 – Possible options for location of pin elastic clamp-holding of column in the corps of wedge

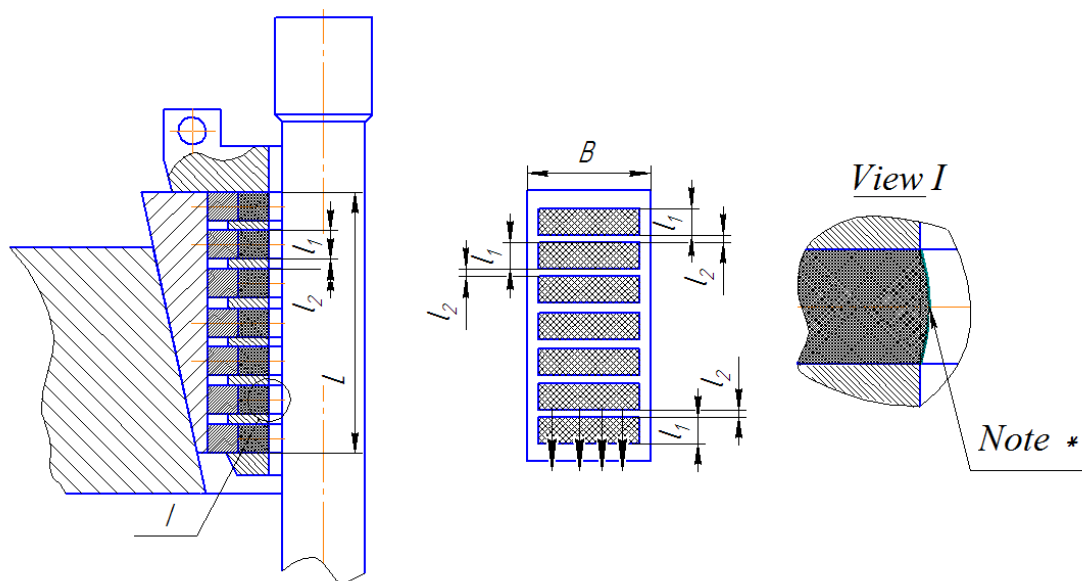

* Note: the surface of the elastic clamp facing of the pipe may be convex to ensure better contact so that it will displace liquid pollutants from the pipe surface

Figure 4 – Spider in the opened position

height of the elastic clamp contact area with the surface of the pipe.

$$l = l_1 n + l_2 (n - 1),$$

where n is the number of contacting elastic clamp holders of the string; all other geometric parameters are shown in Fig. 2 and 3. The number of elastic layers depends on the maximum weight of the pipe column and is equal to 7–25.

The length l can be up to 1.5 meters, meeting the requirements of the pipe holding.

The number of elastic contacting clamps can be 3 or more depending on the diameter of the pipe wedges. According to the preliminary determination, the number of elastic contacting clamps will not be more than 8 for large pipes diameter (over 0.5 m casing, for example).

Further optimizations can be conducted to determine the most efficient parameters for other shapes or configurations of elastic contacting clamps (Fig. 3 b, c, d).

These configurations may affect the duration of work and will be quality indicators of work in the contaminated surfaces of tubes.

The following illustrations (Fig. 4, 5) represent simplified designs and operation of the offered product.

Figure 6 shows the elastic flexible sleeve operation, which should be used for relatively small diameter of tubes, where a is an open sleeve ready for installation at the pipe; b is a sleeve attached to the pipe; c is a sleeve closed onto the pipe; d, e is a sleeve holding of the pipe to which the force of gravity g from the column of pipes is applied.

The arrows in Fig. 6, a, b show the sleeve's direction of movement. The arrows in Fig. 6, c show the direction of movement of lateral parts of the sleeve closed to the pipe. The arrows in Fig. 6, d, e show the direction of action of the compression forces in the process of holding the pipe column.

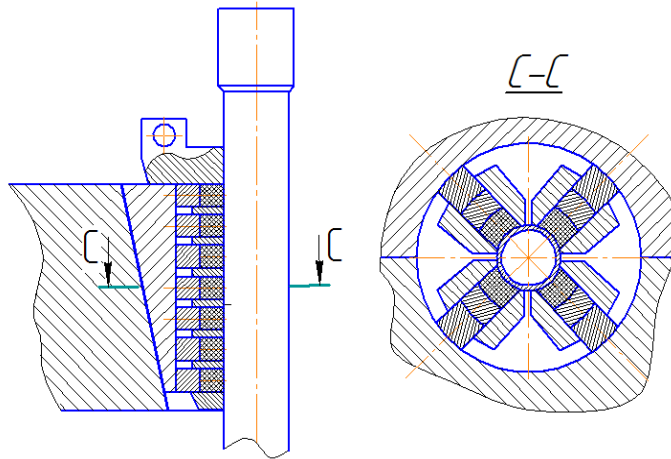
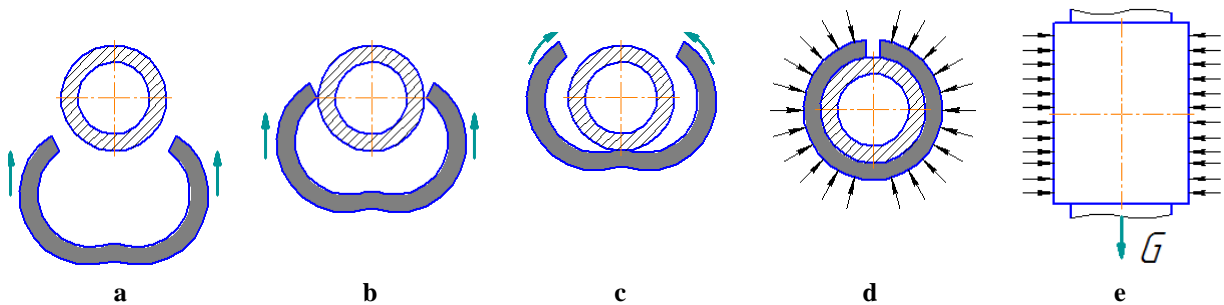
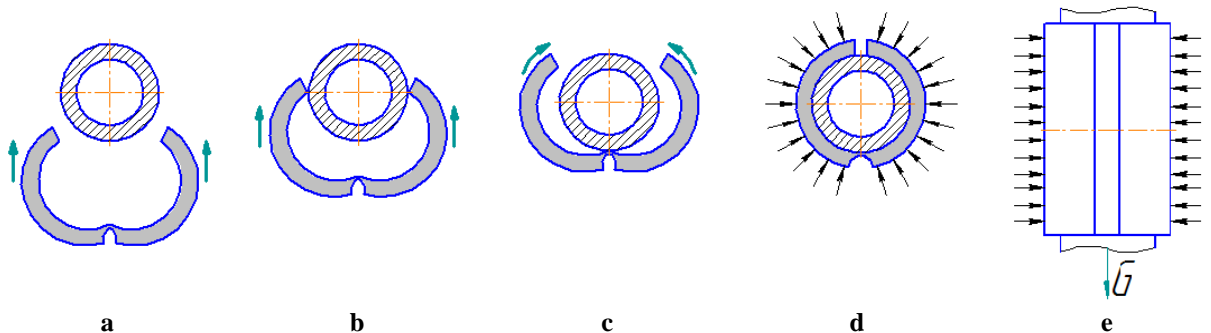

Figure 5 – Operating state (holding the pipes column)



Flexible sleeve: a – in opened position; b – in moving position; c – in contact with pipe; d – in closed position; e – scheme of acting loads

Figure 6 – A flexible elastic sleeve for small diameter pipes. G - axial load (weight of column)



Flexible sleeve: a – in opened position; b – in moving position; c – in contact with pipe; d – in closed position; e – scheme of acting loads

Figure 7 – An elastic sleeve with longitudinal bending grooves for small and medium pipe diameter

Fig. 7 shows the sleeve with a longitudinal groove (hinged design), intended to facilitate the operations. All other information is similar to the information presented in Figure 6.

Figure 8 below shows a sleeve with more longitudinal grooves (multiple hinges) that further simplifies its operation. This Figure shows the sequence of opening the sleeve and its removal from the tube after holding the column. All other information is similar to the information presented in Fig. 13.

There is a number of options for structural solutions of this sleeve design. Some are tested in the laboratory. Our proposal with pads, shown in Fig. 1–6, has several advantages over the sleeve concept.

The study of the stress-strain state of wedge grippers

There is built a three-dimensional model to study the stress-strain state of wedge grippers, and it is shown in Fig. 9. The Ansys Work bench program uses a quarter of wedge grippers to reduce the time for finite-element analysis (Fig. 9).

Fig. 10 shows a design scheme of wedge grippers, in which the pipe and housing are fixed and the load (weight of the drill string) is supported by the wedge. Fig. 11 represents the finite element mesh, formed in the gripper.

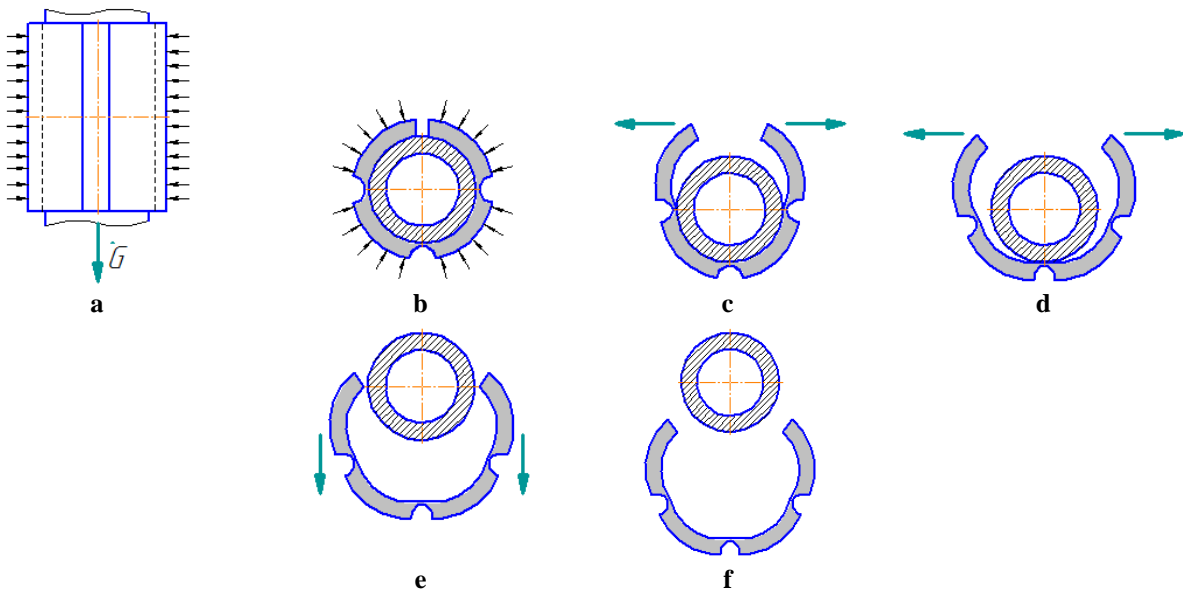

Flexible sleeve: a – scheme of acting loads; b – in moving position; c – in contact with pipe; d – opened position; e – in moving position; f – in separated state

Figure 8 – A sleeve with several longitudinal bending grooves for medium and large pipe diameter

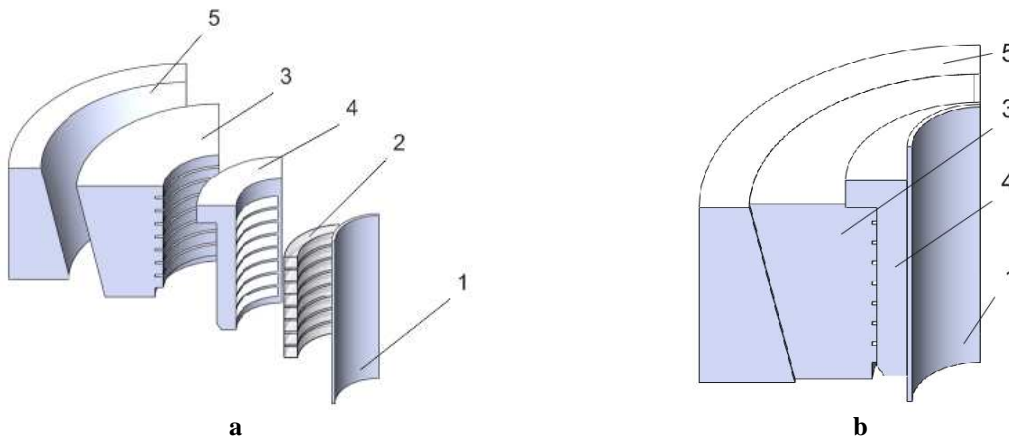

A pipe-spider in: a – an exploded view, b – an assembled condition

1 – a pipe; 2 – a contact elastic clamp (an elastic interface/pad supporting the pipe); 3 – moving wedges
There are 4 moving wedges; 4 – a clamp housing; 5 – a spider housing

Figure 9 – The 3D model of the wedge grippers

There are chosen the following input data:
 loading of the drill string – 1.25 MN;
 height of grippers – 500 mm;
 thickness of ringholder’s shelves – 20 mm;
 cross-section dimensions of rings – 50×50 mm;
 wedge angle – 12°;
 friction coefficient between all pairs of contact – 0.6.

The resulting values of equivalent stresses are presented in Fig. 12, displacements – in Fig. 13, and the strain – in Fig. 14. The contact pressure between contacting surfaces of the grippers is shown in Fig. 15.

The relationship between the contact pressure and the grippers’ height is shown in Fig. 16.

The study of the stress-strain state of interaction with a layer of polyurethane sleeve with pipes and wedges

There is made a three-dimensional model to study the stress-strain state of interaction of the sleeve (layer) made of polyurethane with the pipe and clamping wedges, as it is shown in Fig. 17.

Fig. 18 shows a design scheme, and Fig. 19 – the grid finite element models for the study.

The input data for the study:

- the load of the drill or weight of casing string – 500 tons;
- the height of sleeve: 0.500 m; 0.609 m; 0.914 m; 1.524 m;
- the thickness of a polyurethane sleeve – 0.005 m;
- polyurethane layer is considered fixed (glued) to the contact surface of the pipe.

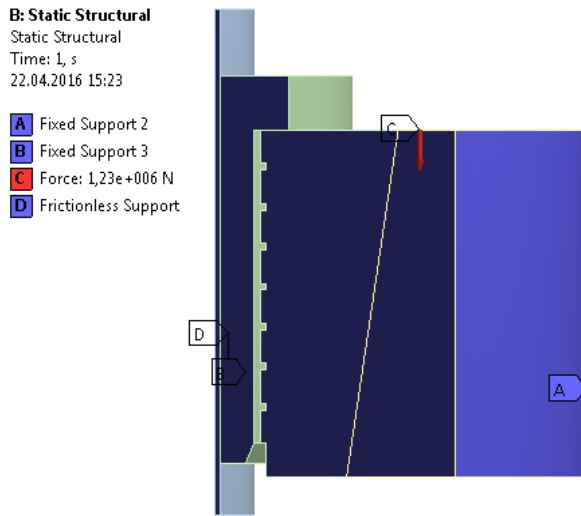

Figure 10 – A design scheme of the wedge gripper

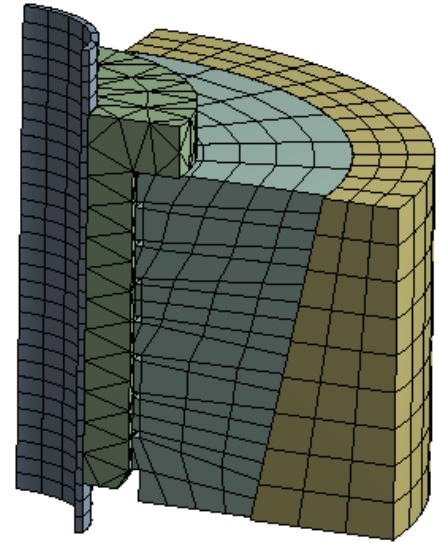

Figure 11 – The finite element mesh in the gripper

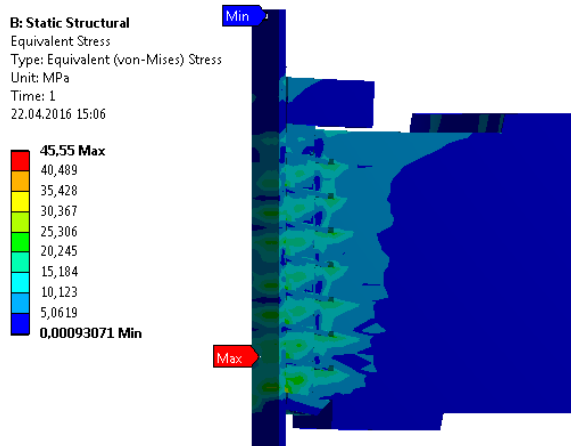

Figure 12 – Distribution of equivalent stresses in the wedge grippers

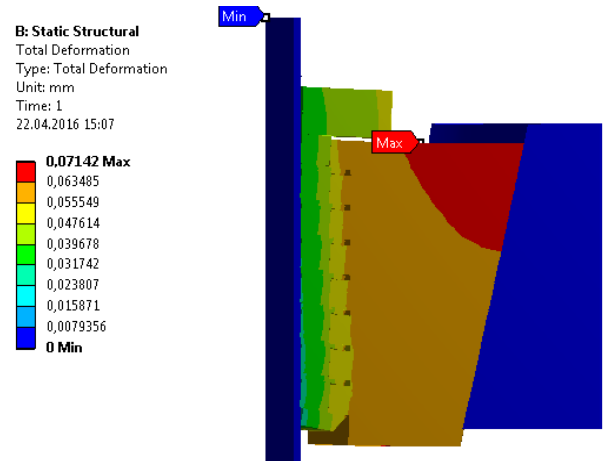

Figure 13 – Distribution of displacements

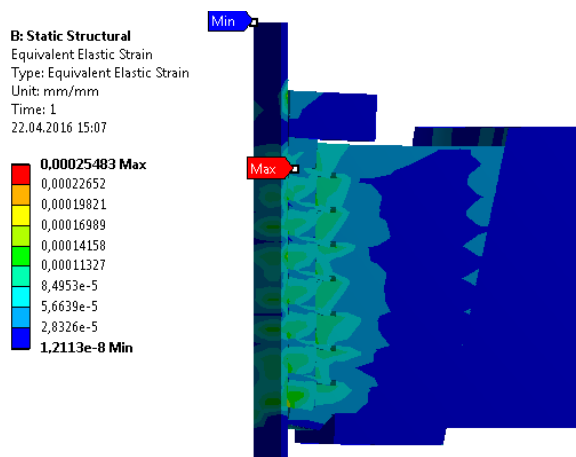

Figure 14 – Distribution of strains

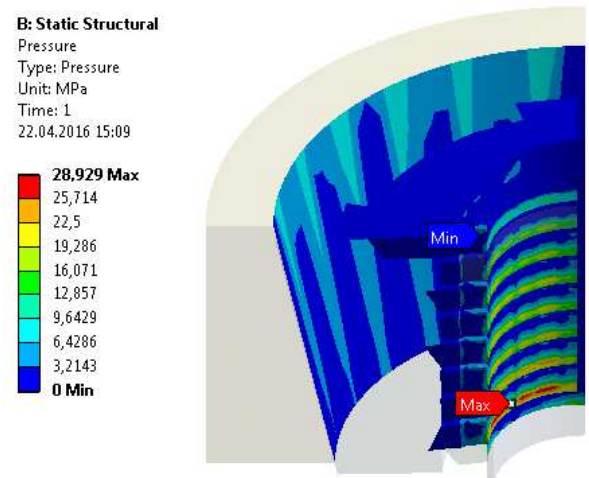

Figure 15 – The distribution of contact pressures between contacting surfaces

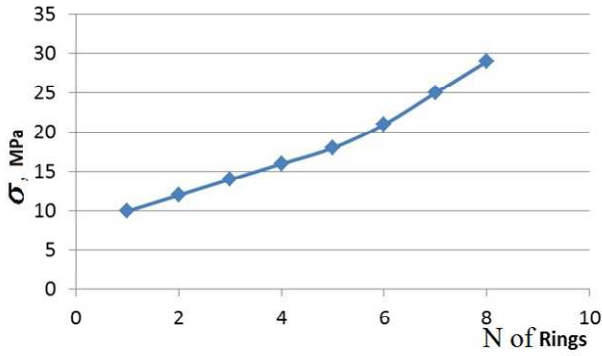
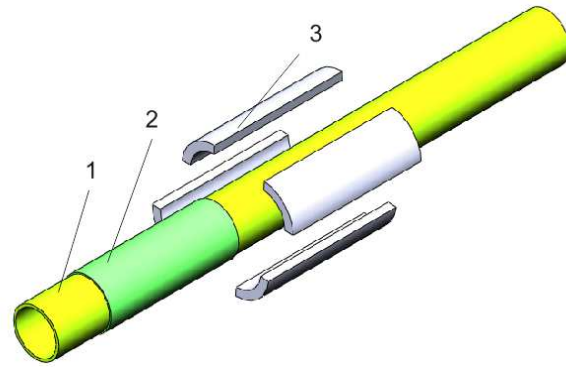

Figure 16 – A graphical relationship between the value of the contact pressure σ along the height of ring grippers



1 – a pipe, 2 – a sleeve; 3 – clamping wedges

Figure 17 – A three-dimensional model

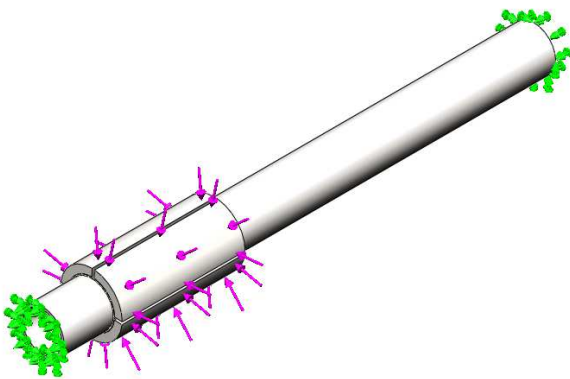

Figure 18 – Calculation scheme

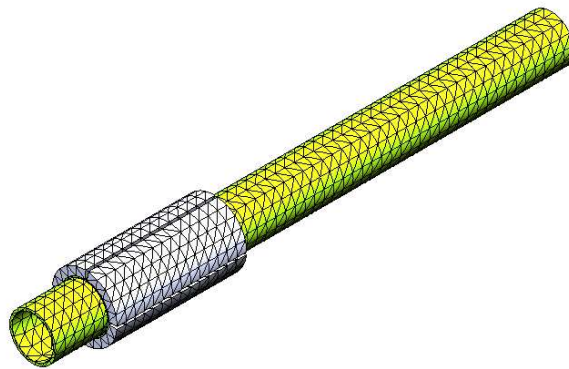

Figure 19 – The finite element mesh

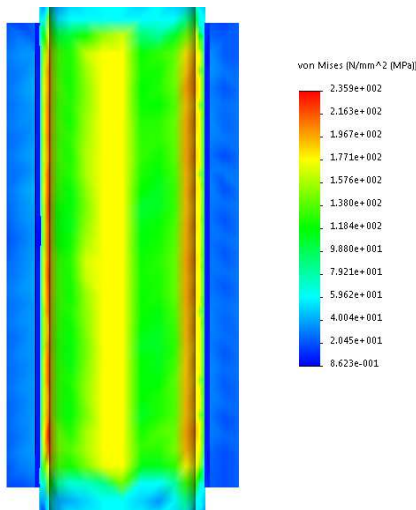

Figure 20 – Distribution of the equivalent stress

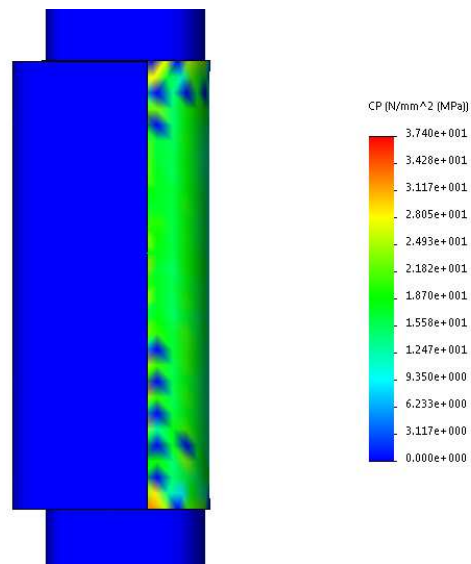

Figure 21 – Distribution of the contact pressure

Fig. 20 and 21 show the results for the clamping wedges with length of 0.5 m as the simulation is conducted by four different geometric dimensions of structural elements.

The dependency between the contact pressure and height of the sleeve (0.500 m, 0.609 m, 0.914 m, 1.524 m) is shown in Fig. 22 below.

Based on the analysis of the results it has been found that the proposed design of the wedge, when grippers are supporting maximum stress, is acceptable for all materials used in the study.

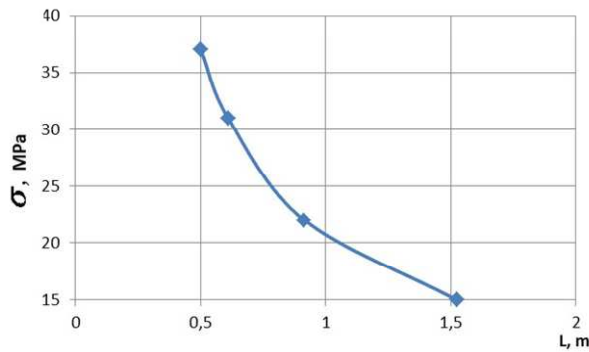

Figure 22 – Graphic relationship between the values of the contact pressure σ along the length of the sleeve

Based on the design features of the wedge grippers, significant deformation of the rings is not observed because the load is distributed among the shelves.

The values of shear stresses in polyurethane sleeve under the action of the column weight are in admissible range.

Conclusions

Each of the proposed solutions does not mark the pipes, and it is designed based on common and well proven oil and gas technologies.

The separate elements of the above proposals were tested on models with positive results.

The finite element modeling demonstrates normal operation of the proposed devices under the required loads.

Having compared the pads and sleeve concepts we found that the first one had several advantages over the second.

References

- [1] Kopey, BV & Kopey, VB 2010, *Sucker rods for pumping units*, IFNTUOG, Ivano-Frankivsk. (in Ukrainian).
- [2] Kopey, BV, Maksymuk, OV, Shcherbyna, NM 2003, *Sucker rods and pipes made of polymer composites*, IAPMM NAS Ukraine, Lviv. (in Ukrainian).
- [3] Panasyuk, VV (ed. in chief) 2006, *Fracture mechanics and strength of materials. Reference manual*, Kyiv, Naukova dumka; V.10: *Strength and longevity of oil and gas equipment*, Karpenko FMI of the NAS Ukraine, IFNTUOG, Lviv-Ivano-Frankivsk. (in Ukrainian).

УДК 622.24.053

Розробка непошкоджувального трубоутримуючого обладнання

Б.В. Копей, М.М. Лях, Ю.М. Лях, В.В. Михайлюк

*Івано-Франківський національний технічний університет нафти і газу;
вул. Карпатська, 15, м. Івано-Франківськ, 76019, Україна*

Наведено рекомендації технічного рішення для запобігання руйнування зовнішніх поверхонь бурильних і обсадних труб клиновими захоплювачами в процесі виконання спуско-підіймальних операцій. Також запропоновано конструктивне вирішення затискання поверхні труб при їх згвинчуванні або розгвинчуванні. Проведено дослідження запропонованих технічних рішень захоплювачів з використанням комп'ютерних моделей. Встановлені основні параметри елементів конструкції запропонованих клинового захоплювача та затискача, що можуть забезпечити технологічний процес без руйнування зовнішніх поверхонь труб нафтового сортаменту.

Ключові слова: *клиновий захоплювач, непошкоджувальне обладнання, різьбове з'єднання, спуско-підіймальні операції, труба.*