

GEOPHYSICAL INSTITUTE

UNIVERSITY
OF ALASKA

COLLEGE
ALASKA

UAG R45

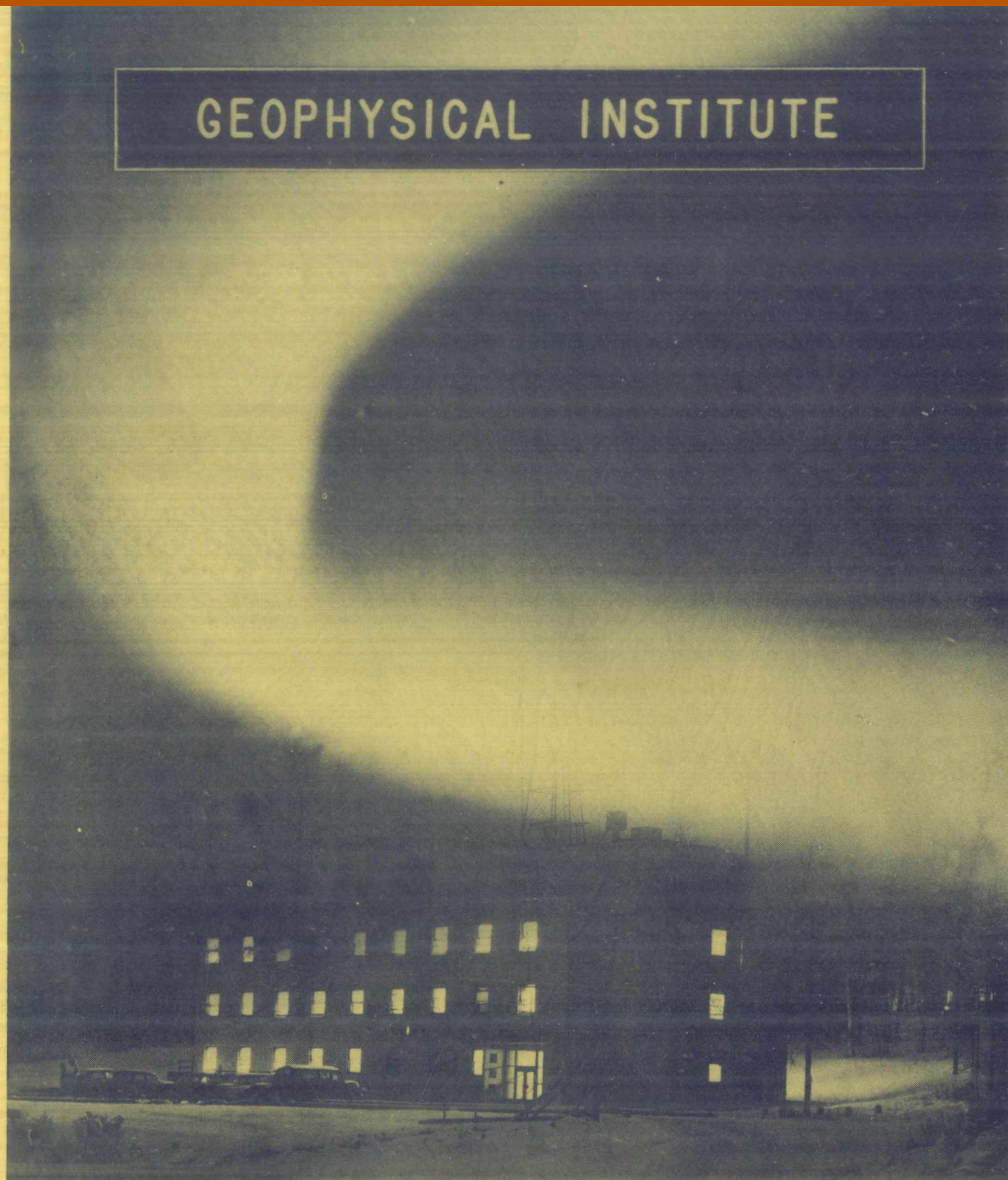

AURORAL ZONE ABSORPTION OF RADIO WAVES TRANSMITTED VIA THE IONOSPHERE

Tasks A and B

Quarterly Progress Report No. 6
1 September to 30 November 1955

Signal Corps Contract	No. DA-36-039-SC-56739
Dept. of the Army Project	No. 3-99-03-022
Signal Corps Project	No. 182B

Laboratory Procurement Office, Signal Corps Supply Agency
Fort Monmouth, New Jersey

GEOFYSICAL INSTITUTE

of the

UNIVERSITY OF ALASKA

AURORAL ZONE ABSORPTION OF RADIO WAVES
TRANSMITTED VIA THE IONOSPHERE

Tasks A and B

Quarterly Progress Report No. 6

1 September 1955 to 30 November 1955

The object of this project is to conduct studies of propagation
of radio waves in the auroral zone.

Signal Corps Contract	No. DA-36-039 SC-567 9
Department of the Army Project	No. 3-99-03-022
Signal Corps Project	No. 182B

Report Prepared By:

Leif Owren

Robert Stark

Report Approved By:

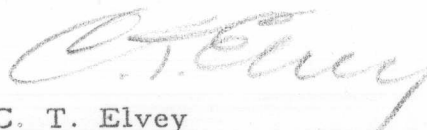

C. T. Elvey
Director of the Institute

TABLE OF CONTENTS

		Page
Section I	Purposes	1
Section II	Abstract	2
Section III	Publications, Lectures, Reports and Conferences	2
Section IV	Factual Data	2
	Task A: Transmission of H. F. Radio Waves	2
	Task B: Pulse Techniques. Backscatter at 12 mc.	3
	Task B: Visual Observations of Aurora	17
Section V	Conclusions and Recommendations	18
Section VI	Plans for Next Quarter	19
Section VII	Personnel	19

Errata for Quarterly Progress Report No. 6
DA-36-039-SC-56739

<u>Page</u>	<u>Line</u>	<u>Read</u>	<u>For</u>
2	2	has been completed	completed
3	12	3,300	3,300
4	Fig. 1	HF	VHF
5	1	not to cause	to not cause
8	10	6 kw	0 kw
11	14	is at	is

SECTION I

PURPOSES

Task A:

To conduct research studies of auroral zone absorption of radio waves transmitted via the ionosphere and to provide the services of a supervisory engineer for the stations operated by the Arctic Ionosphere Research Detachment and by the University of Alaska. This task is a continuation of, but over and beyond, Task A under Contract No. DA-36-039-SC-5512.

Task B:

To perform radio back-scatter observations of direct scatter from aurora-associated E-layer ionization; to observe the aurora visually in the region of scatter, and to correlate these observations with the field intensity measurements obtained under Task A. This is a continuation of, but over and beyond, Task B under Contract No. DA-36-039-SC-5512.

SECTION II

ABSTRACT

Signal intensity operations have stopped and the preliminary reduction of all field intensity records completed. The 12 mc backscatter equipment is described and operating conditions stated. Tentative interpretations of observed echoes in terms of possible reflection mechanisms are given.

SECTION III

PUBLICATIONS, LECTURES, REPORTS, AND CONFERENCES

No publications, lectures, reports, or conferences were given during this quarter.

SECTION IV

FACTUAL DATA

Task A. Transmission of H. F. Radio Waves.

All stations have operated in a satisfactory manner during the period covered by this report. Pursuant to directions from Evan's Signal Laboratory, all signal intensity operations ceased on October 20, and all AIRD equipment has been turned over to the Geophysical Institute until final disposition has been decided on. The preliminary scaling of all field intensity records into hourly median values has been completed.

Task B. Pulse Techniques: Back-scatter at 12 mc.

1. Description of the Equipment.

The 12 mc radar at College, Alaska, consists of the following basic units: transmitter, receiver, keying unit, display system, and antenna system (see Fig. 1).

a. Transmitter.

The basic frequency generating unit of the transmitter consists of two crystal controlled oscillators of the Hartley type operating at the frequencies of 2852.5 kc and 3300.0 kc respectively. The 2852.5 kc oscillation is amplified and frequency doubled in the plate circuit of the amplifier. The resulting sinusoidal wave of frequency 5705 kc is fed to a mixer stage. The output of the 3.300 kc oscillator is fed into an amplifier which is keyed with a pulse (square-wave) of predetermined length. The frequency of the oscillation is doubled in the plate circuit of the amplifier so that the output is a pulse of radio frequency 6600 kc. This pulsed output is fed to the mixer stage mentioned above where it is combined with the sinusoidal 5705 kc wave to give a pulse having a radio frequency of 12.305 mc. The advantage of this type of frequency mixing is that there will be no sinusoidal wave frequencies to interfere with the receiver during the transmitter off-time between successive pulses. The crystals are chosen so that any harmonic frequency, which is generated and radiated by the oscillators, will be so far removed

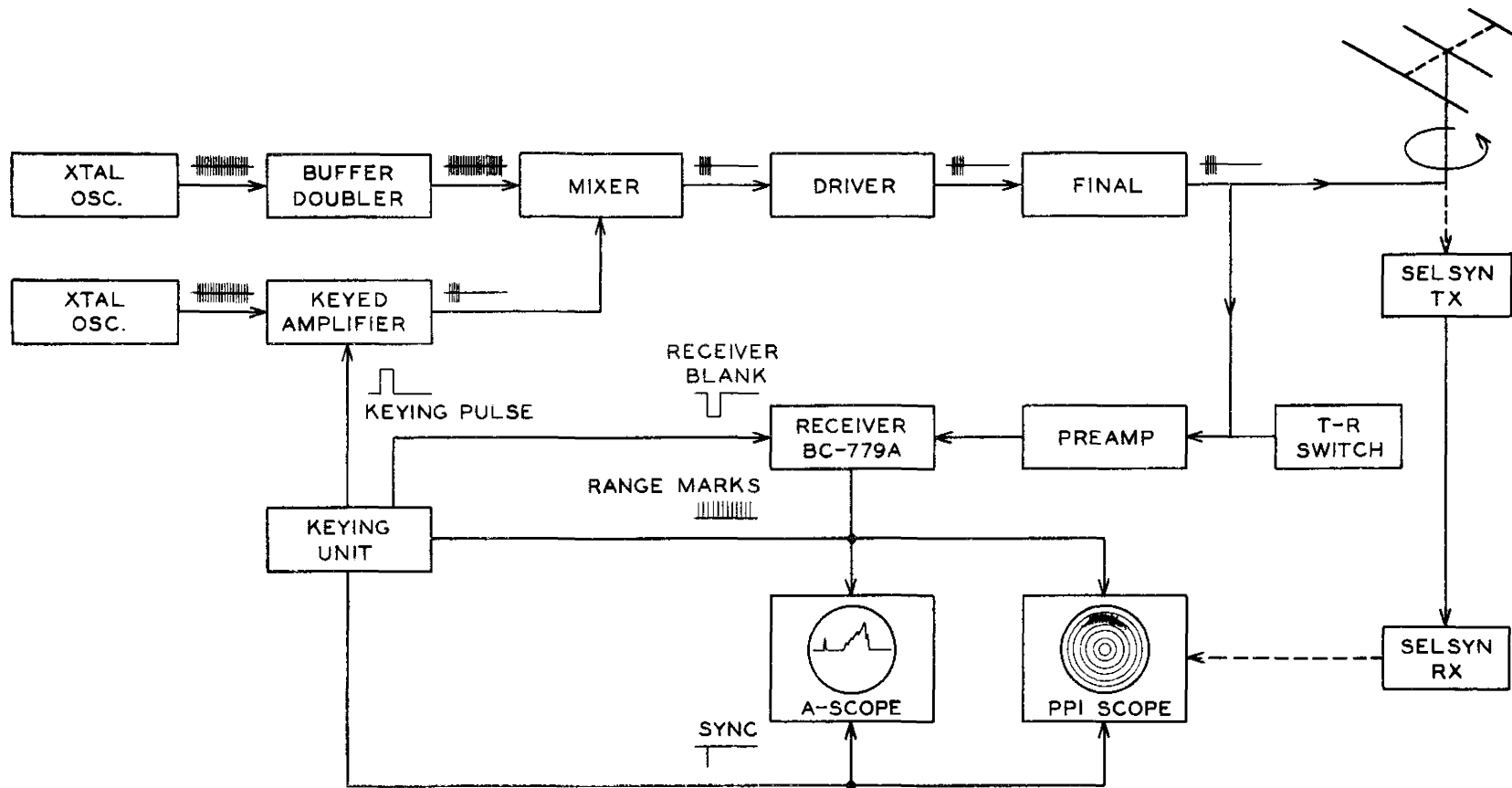

BLOCK DIAGRAM OF VHF RADAR EQUIPMENT

FIG. 1

from the final operating frequency so as to not cause interference. All stages described so far operate with tubes of type 6AG7.

The pulsed output from the mixer stage is amplified in a driver stage using a type 807 tube and is then further amplified in the final stage consisting of two tubes of type 4-250 A operated in push-pull arrangement.

The final stage is link-coupled to a 75 ohm coaxial transmission line. This line runs out to a rotating antenna-tower and is inductively coupled to the antenna through a rotating coupling.

b. Receiver.

The receiver, connected to the transmission line at the transmitter, consists of a one-stage preamplifier and a BC-779 B receiver. The receiver, crystal controlled, has been modified for pulse work. A transmit-receive (T-R) electronic switch is used at the receiver so that the transmitter pulse will not block the receiver. The receiver is also blanked during the transmitter pulse by driving the suppressors of the two RF amplification stages and the first IF amplifier stage negative.

c. Keying Unit.

The keying unit is a complex device serving a variety of functions: it provides range marks, establishes the pulse repetition frequency (PRF), provides the transmitter keying pulse, the receiver blanking pulse and synchronization for the display scopes.

The basic frequency unit is a 1000 cycle tuning fork. The 1000 cycle signal is fed through wave-shaping circuits to produce pulses at a PRF of 1000, which are used directly for 150 km range marks.

The 1000 pulses per second are also fed through a series of counters to provide preselected PRF's of 200, 100, 50, or 25. These pulses are then used to trigger the multivibrator which forms the transmitter keying pulse and are used directly as synchronizing pulses for both oscilloscopes. The receiver blanking pulse and transmitter keying pulse are of variable length because it is usually desirable to operate with very narrow receiver band width and maximum pulse width.

d. Display System.

Two display scopes are presently being used: an A-scope and a plan position indicator (PPI). The A-scope, or range-amplitude display, a laboratory model Heathkit, is being used primarily for visual observations to augment information collected on the PPI display. The PPI display is being photographed continuously with a modified 16 mm movie camera at the rate of one frame per antenna rotation. The PPI scope, part of an SCR-271 radar, has been modified considerably for work at long ranges and low PRF's. The sweep circuit has been added externally since the original equipment operated at much higher PRF's.

The deflection coil has been replaced by a standard television yoke and is driven by a pair of parallel 807's in a cathode follower circuit. 150 km range marks are mixed with the detector output and fed to the cathode of the cathode ray tube.

e. Antenna System.

The antenna is a 3-element yagi array. The driven element is a folded dipole fed by an open-wire transmission line running from the antenna down the tower to the rotating coupling. The other link of the coupling transformer is connected to a 75 ohm coaxial cable running to the transmitter. Impedance matching is obtained at the coupling by means of series-parallel tuned circuits. The tower rotates at constant speed slightly faster than one rpm.

A selsyn system, geared to the antenna tower and the deflection coil on the PPI, is used to synchronize sweep azimuth with antenna azimuth.

Circuits for special projects which have also been constructed and incorporated into the equipment include gating and blanking circuits for determining amplitude fading of echoes and several camera control circuits for various modes of operation. All of this equipment except for the receiver and one of the oscilloscopes has been constructed at the Institute.

2. Operation of the Equipment.

a. Mode of Operation.

Typical operating conditions are as follows:

A PRF of 50, pulse length of 400 microseconds, average plate current of 40 milliamps, with 4000 v, is applied to the final. Therefore, average power input is about 160 watts. With a duty factor of 50, peak power input is approximately 8 kw. Assuming a transmitter efficiency of approximately 70 per cent, the maximum radiated power under matched conditions is therefore between 5 and 0 kw.

The 12 mc radar has been operated with the PPI display over most of the past quarter. Some difficulty has been experienced in obtaining continuous records, but the various problems having been solved, this equipment is now in satisfactory operating condition. Receiver drift due to temperature changes at the present site has been corrected by crystal-controlling the receiver. Photographing the PPI scope caused some difficulty because this procedure requires a camera which will operate with open shutter for a complete revolution and advance the film once per revolution. The only available camera required considerable modification for this method of operation.

b. Observations and Tentative Interpretations.

Usable continuous data have been obtained with the radar

equipment in its present form for the last several weeks. In addition, many observations have been made during the past several months, but the records have not been continuous. This report will be limited to phenomena which are being investigated and tentative interpretations of those phenomena. They may be divided into three groups: groundscatter via the F-layer, sporadic E scatter (both direct and groundscatter) and auroral scatter.

i. Back-scatter from Ground Via the F-region.

Groundscatter via the F-layer (see Fig. 2) has been observed at all azimuths and at all times of the day. Double-hop F-layer groundscatter has also been observed at all azimuths but not at all times of the day because night-time critical frequency of the F-layer is so low that, if the double-hop occurs, it is out of the maximum range of the equipment, which is slightly less than 5000 km. Single-hop echoes have been observed at night out as far as 3500 km; therefore, the double-hop might be expected at about 7000 km. It is interesting to note, however, that the apparent echo maxima in the double-hop echoes are not always exact multiples of each other. Because the respective reflecting areas in the ionosphere may be separated by distances of the order of 1500-2000 km, the critical frequencies and virtual heights may also vary considerable. We are request-

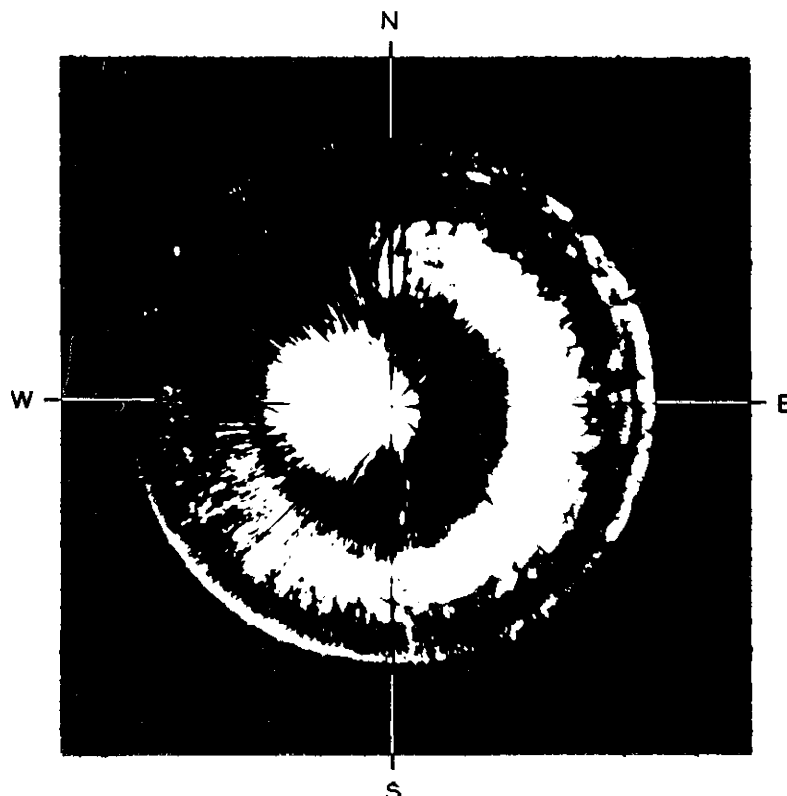

S
FIG. 2

PPI photo showing F-region groundscatter. Double-hop echo appears on outer edge and blanketing sporadic E in the NW quadrant.

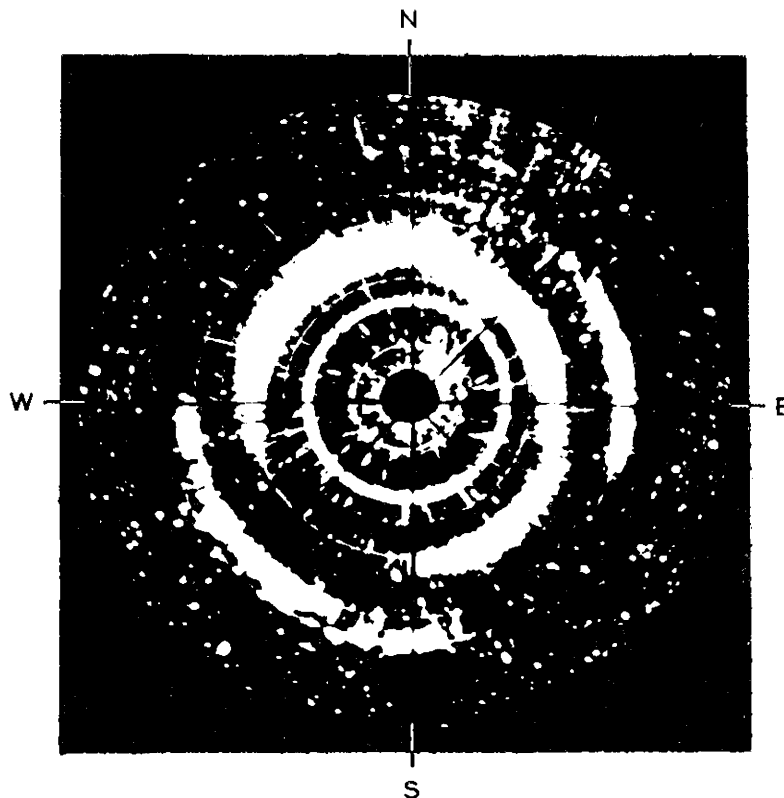

S
FIG. 3

PPI photo showing direct scatter from an auroral type echo at 450 km blanketed by a layer in the SW which gives a ground scatter echo at 700 km.

ing data from ionospheric vertical incidence sounders within our radius of operation for correlation purposes.

ii. Sporadic E Echoes.

Sporadic E echoes have been observed at ranges from 150 km to 800 km. If we assume a height of 100 km for the layer, it is probable that both direct scatter or groundscatter echoes occur. The short range echoes are certainly not groundscatter, and it is unlikely that echoes at 800 km would be direct-scatter.

Further evidence for groundscatter exists in the type illustrated in Fig. 3. It appears that the short range echo is solid except in the southwest quadrant, where an echo appears at a greater range. The first echo, exhibiting rapid fading characteristics, is approximately 450 km. The E_s echo in the SW quadrant is at about 700 km. This long range echo could blanket the first echo only if it is groundscatter, i. e. the reflecting area in the ionosphere is actually at 350 km and below the region which gives rise to the shorter range echo. In making such an interpretation of the record, we have used the amplitude fading criteria, as reported in Quarterly Report No. 6, as a means of identifying the echo source. This illustration is a good example of the ambiguities which arise in interpreting records. The overlapping of the

echoes is due to the antenna beam width, approximately 50°. In way of further explanation, the first solid ring in the center of the photograph is the tail of the transmitter pulse used as a reference line.

iii. Auroral Echoes.

Auroral type echoes have been observed at ranges from 150 km to 2700 km. These echoes can be divided into two range groups: from 150-1100 km and from 2000-2700 km. We shall discuss the latter group first.

Long-Range Echoes.

Using the fading criteria as a means of identifying the echoes as well as the aspect sensitivity of V.H.F. auroral reflections discovered at College, the following interpretation has been made: echoes appearing at ranges in excess of 2000 km must be F-layer propagated auroral echoes. If we assume the virtual height of the F-layer in the reflecting area to be 250 km and the height of the auroral columns to be approximately 100 km, then an F-layer groundscatter echo at 2000 km could be followed by an auroral echo at 2400 km (see Fig. 4).

An interesting variation of this phenomenon, which has been observed on several occasions consists of an auroral echo appearing at 2400 km, although the groundscatter echo

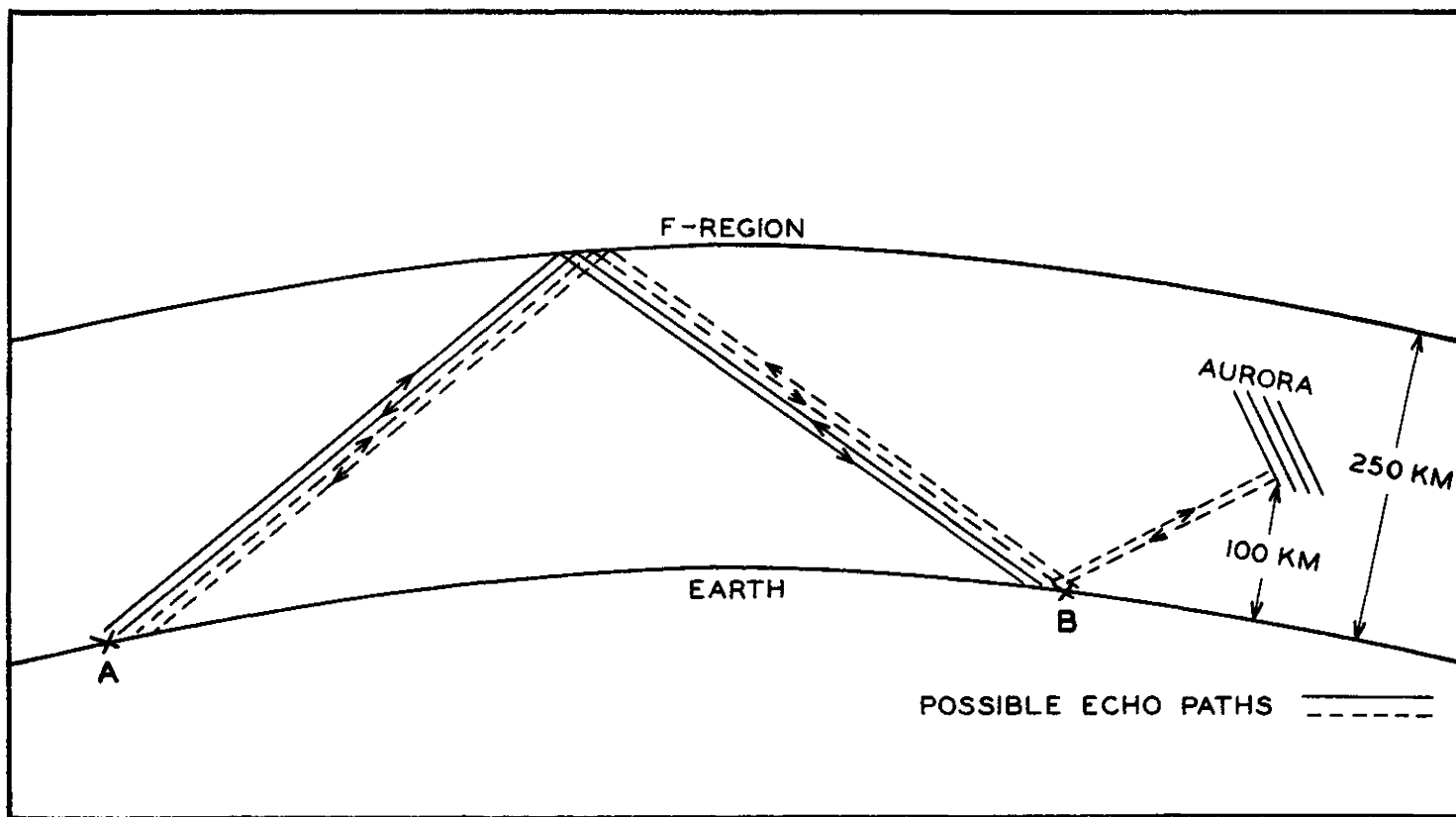

F-REGION PROPAGATED AURORAL ECHOES

FIG. 4

at 2000 km is not visible on the scope. These particular echoes may be explained by assuming that the forward-scatter at point B in Fig. 4 is much stronger than the backscatter at that point. Such would be the case if the ground offered a plane reflecting surface there. Now, in general, sea or land reflection at 12 mc is apt to be a plane reflection. Therefore, the groundscatter from point B coming back to the receiver via the F-layer could well be weaker than the back-scatter from the auroral ionization reflected at that same point and similarly reaching the receiver via the F-layer. Thus, the auroral echo could, on occasions, be visible although the groundscatter is not. It is not likely that an alternative mechanism of direct back-scatter from auroral ionization columns after deviative penetration of the F-layer, invoked by investigators at Stanford University, is at work because of the high critical frequencies recorded here for the F-layer at the time of our observations. Experience has shown that stations in higher latitudes do not record values of the F-layer critical frequency which are significantly lower than those found in College.

The lack of echoes between 1100 and 2000 km is due to the auroral echoes usually occurring at night when F-layer

minimum range is usually greater than 1500 km.

Short Range Echoes.

The short range auroral echoes have been observed at all azimuths and at all hours of the day. The azimuth distribution observed at 12 mc appears to tie in well with that found by V. H. F. back-scatter techniques. Work done at College by Bowles and Dyce¹ at 107 mc and 50 mc shows a very definite aspect sensitivity at those frequencies and further shows that assuming the auroral columns are parallel to the lines of force of the earth's magnetic field, the off-perpendicular angle at which echoes may be received is inversely proportional to frequency. Taking into account the difference in frequency and extrapolating from the V. H. F. results, one would expect it possible to receive auroral scatter at off-perpendicular angles as great as 25° at 12 mc. Assuming the height of the aurora to be 100 km, and making use of the fact that the inclination of the earth's magnetic field is about 77° for College, we calculate the minimum range for auroral echoes in the south to be approximately 450 km and to the north about 150, a fact confirmed by observational results. Auroral echoes have never been observed closer than 500 km in the south. Also, homogeneous bands which

cross the zenith and extend to the horizon on both sides give echoes at about 350 km in the east and west. This range supports an aspect sensitivity of 20°-25° off-perpendicular at 12 mc. This particular echo occurrence has been observed many times when visual homogeneous bands were present to confirm the echo origin.

iv. Other Echoes Including Transitional Forms.

Sporadic E echoes with a near 360° azimuth distribution have been observed which undergo very sudden changes in fading characteristics so as to become similar to the fading associated with auroral echoes. This would seem to indicate a transition from the most common type of sporadic E back-scatter to the auroral type back-scatter. The transition is apparent only when the A-scope is observed visually and has only been noticed recently. After becoming aware of these echoes, more careful observations have been made and the phenomena has been observed several times. It has only been observed during daylight hours, early morning, or late afternoon, and cannot be compared with visual auroral observations. It is therefore planned to make further amplitude-fading studies of these echoes and to compare records from other types of equipment to see if there is a transitional

state of aurora. Some observers have mentioned an "auroral E." It is possible that it is this phenomena we are observing or some form of "low-intensity" aurora.

REFERENCE

1. R. B. Dyce, Technical Report No. 23, School of Electrical Engineering, Cornell University, June, 1955.

Task B. Visual Observations of Aurora.

The method of recording visual observations of auroras was revised in order to test the method developed by C. W. Gartlein of recording on IBM mark-sense cards. However, the closing of the field stations on October 20, 1955, resulted in such a small amount of data that a test of the method is inconclusive.

The data for the previous season has been recorded on IBM punched cards. As previously, the analysis of the auroral observations will be with respect to magnetic activity. A master set of punched cards with K-indices for Pt. Barrow and College are being prepared. The appropriate K-indices will be transferred to the cards with the auroral data and the analysis undertaken.

The IBM equipment at Ladd Air Force Base is being used for this work whenever the equipment is available.

SECTION V

CONCLUSIONS AND RECOMMENDATIONS

The 12 mc radar is now in good operating condition and is securing continuous back-scatter data. Back-scatter from the ground is received both via the F-layer and via sporadic E ionization. Direct back-scatter from the ionosphere is observed in connection with sporadic E and auroral ionization. There appear to be long-range auroral echoes which return to the receiver over a path involving one ground and one F-layer reflection. Sudden transitions from sporadic E type back-scatter to auroral type back-scatter have been noted.

The back-scatter technique represents an important tool in radio wave propagation studies for the following two reasons: (1) The 12 mc radar actually looks at the propagation path and reports disturbances and irregularities occurring on it and, (2) the radar provides information on the character and distribution in space of the disturbances and irregularities at all azimuths and over distances up to 5000 km.

In view of the wealth of information now being gathered through the continuous operation of the 12 mc radar equipment and the variety of echoes being discovered, it is recommended that the back-scatter observations at 12 mc be continued. It is further recommended that the visual observations of aurora be continued so as to make possible detailed comparison between the occurrence of auroral light in its different forms and the different types of back-scatter at 12 mc.

SECTION VI

PLANS FOR NEXT QUARTER

Task A.

Methods for analysis of the Task A data will be studied and the desirability of further scaling of the records considered.

Task B.

As usable data accumulate, a study of range, azimuth, and time distribution is planned for all forms of back-scatter; F-layer, sporadic E, and auroral. Particular attention will be paid to transitional forms as well as back-scatter sources causing blanketing. Possible correlations with visible aurora will be investigated.

SECTION VII

PERSONNEL

C. T. Elvey	Project Supervisor
C. G. Little	Assistant Project Supervisor
Leif Owren	Research Associate (from 1 Feb., 1956)
S. J. Andersen	Supervisory Engineer
R. Stark	Electronic Technician
Paula Beebe	Technician
Leta Ann Seitz	Technician
LaNelle Bergt	Technician
Grace Lobanov	Technician
Marion Mitchell	Technician
E. M. Tikka	Technician
Carole Smith	Technician