

**UCC Library and UCC researchers have made this item openly available.  
Please [let us know](#) how this has helped you. Thanks!**

<b>Title</b>	Techno-economic analysis of high potential offshore wind farm locations in Turkey
<b>Author(s)</b>	Cali, Umit; Erdogan, Nuh; Kucuksari, Sadik; Argin, Mehmet
<b>Publication date</b>	2018-11-02
<b>Original citation</b>	Cali, U., Erdogan, N., Kucuksari, S. and Argin, M. (2018) 'Techno-economic analysis of high potential offshore wind farm locations in Turkey', <i>Energy Strategy Reviews</i> , 22, pp. 325-336. doi: 10.1016/j.esr.2018.10.007
<b>Type of publication</b>	Article (peer-reviewed)
<b>Link to publisher's version</b>	<a href="http://www.sciencedirect.com/science/article/pii/S2211467X1830097X">http://www.sciencedirect.com/science/article/pii/S2211467X1830097X</a> <a href="http://dx.doi.org/10.1016/j.esr.2018.10.007">http://dx.doi.org/10.1016/j.esr.2018.10.007</a> Access to the full text of the published version may require a subscription.
<b>Rights</b>	© 2018 Elsevier Ltd. All rights reserved. This manuscript version is made available under the <b>CC-BY-NC-ND 4.0 license</b> <a href="http://creativecommons.org/licenses/by-nc-nd/4.0/">http://creativecommons.org/licenses/by-nc-nd/4.0/</a>
<b>Item downloaded from</b>	<a href="http://hdl.handle.net/10468/7179">http://hdl.handle.net/10468/7179</a>

Downloaded on 2021-11-27T05:21:52Z

# TECHNO-ECONOMIC ANALYSIS OF HIGH POTENTIAL OFFSHORE WIND FARM LOCATIONS IN TURKEY

Umit CALI<sup>\*a</sup>, Nuh ERDOGAN<sup>b</sup>, Sadik KUCUKSARI<sup>c</sup>, Mehmet ARGIN<sup>d</sup>

<sup>a</sup>*Department of Engineering Technology and Construction Management,  
University of North Carolina at Charlotte, NC, USA*

<sup>b</sup>*Marine and Renewable Energy Centre, University College Cork, Cork, IRELAND*

<sup>c</sup>*Department of Technology, University of Northern Iowa, Cedar Falls, IA, USA*

<sup>d</sup>*Engineering Department, Houston Community College, Houston, TX, USA*

---

## Abstract

The wind energy market is rapidly growing in Turkey which made it one of the top three countries in Europe, and the seventh in the world, in terms of wind power capacity addition in 2016. Turkey has high onshore and offshore wind power potential which is widely distributed across the country. However, there has been no offshore wind farm (OWF) in operation in Turkey. This paper performs a comprehensive techno-economic analysis of OWF projects in three of the most promising wind locations (namely, Bozcaada, Gokceada, and Bandirma). The optimal OWF sites are selected by applying a multi-criteria site selection method to Turkey's coastal regions. Technical analysis consists of annual energy production estimation using the Virtual Wind Farm model and development of various electrical system design topologies for the proposed OWF projects. A detailed economic feasibility analysis is then conducted using a discounted cash flow economic model that considers current Turkish renewable energy support schemes under various discount rates. Taking the OWF investor's perspective, this study accounts for the key economic indicators which are used in the decision-making processes. The results of various model runs are compared to determine the best options for the proposed OWF investments to be profitable. It is shown that the proposed OWF projects are economically feasible only in the case of meeting certain techno-economic conditions. The radial electrical design is proved to be the most cost-effective option. Among the proposed projects, the Bozcaada OWF appears to be the best investment option with a levelized cost of electricity (LCOE) of \$81.85-109.55 per MWh while the Bandirma OWF is the least economically viable with an LCOE of \$100.73-135.97 per MWh. The findings are extrapolated to suggest feasible recommendations for the investors and policy makers which will help to shape the offshore wind energy outlook of Turkey.

*Keywords:* Feasibility, levelized cost of electricity, offshore wind power, site selection, Turkey

---

\*Corresponding author

*Email addresses:* [ucali@uncc.edu](mailto:ucali@uncc.edu) (Umit CALI\*), [nuh.erdogan@ucc.ie](mailto:nuh.erdogan@ucc.ie) (Nuh ERDOGAN), [sadik.kucuksari@uni.edu](mailto:sadik.kucuksari@uni.edu) (Sadik KUCUKSARI), [mehmet.argin@hccs.edu](mailto:mehmet.argin@hccs.edu) (Mehmet ARGIN)

## 1. Introduction

Ensuring and improving global energy security has prompted developed countries to move towards renewable energy resources [1]. Accordingly, they have been stretching the goals of using renewable energy resources over the past decade [2]. Among various renewable energy resources, wind energy has been a leading form of renewable energy in terms of installed capacity [3]. As of 2016, global installed wind power generation accounts for about 53% of the total renewable power capacity, excluding conventional hydropower [4]. According to the Global Wind Energy Council (GWEC) report, global cumulative installed wind power capacity has increased from 17.4 GW to 486.8 GW between 2000 and 2016. In terms of wind power penetration level, Denmark is the leading country with 40%. Among the top eleven electricity markets, Spain and Germany produce 20% and 16% of their powers from wind respectively, followed by Canada, the US, and China with 6%, 5.5%, and 4% [5]. The use of wind energy is expected to maintain its market growth given the expected increase in wind turbine size and efficiency [6]. The GWEC projected that wind energy could supply 20% of global electricity by 2030.

In the growing wind energy market, offshore wind energy may become indispensable due to restrictions of land availability for onshore installations [7, 8]. For example, offshore wind energy is expected to be a major component in achieving the UK's renewable energy and emissions targets [9]. Annual cumulative offshore wind power capacity has increased almost triple fold in the last 5 years, reaching the cumulative capacity of 14.384 GW as of 2016 [5]. European countries are dominating with a cumulative installed offshore wind power capacity of over 12.6 GW in which the UK and Germany are the top countries with a total of over 5 GW and 4 GW, respectively [10]. Accordingly, European policymakers have developed various support schemes for promoting offshore wind energy such as tradable green certificates in the UK and Belgium, Feed-in-Tariff (FiT)/ Feed-in-Premium (FiP) in Denmark, Germany, Netherlands, and Italy, and exemption of the Climate Change Levy and Carbon Price Floor in the UK [11, 12]. Also, Denmark, the Netherlands, and Belgium identify offshore development sites and support early-stage activities (e.g., environmental assessment, geotechnical surveys etc.) [13]. Among various support schemes, tariffs in the FiP scheme are determined for each wind project through a competitive tender procedure, while a fixed tariff is set in the FiT scheme by corresponding a government agency. The cost of offshore installations is extremely affected by their site conditions as opposed to their onshore counterparts. The FiP is found to be the most appropriate support scheme and is also expected to expand in the future offshore wind farms (OWFs) since the tariff is driven by market mechanisms that consider the specific conditions of projects. For example, in Denmark the tenders recently resulted in diverse incentives depending on the offshore region conditions, such as an incentive level of 84.4 €/MWh, 103.1 €/MWh, and 105.1 €/MWh for Rødsand 2, Horns Rev3, and Anholt OWFs respectively. The FiT is paid for the first 50,000 equivalent full-load hours, which corresponds to between 11 and 12 years of normal operations in Denmark. It was shown in [11] that the given favorable schemes have definitely had a positive impact on the wind energy deployment. However, current regulatory policy, support, and economic schemes are still found to be the main barriers to

the massive proliferation of OWFs [14].

Meeting the goals of renewable energy use requires such a public commitment [2] that the government encourages the technology development with support schemes, regulatory, and incentive policies. These policies include financial support, feed-in-tariffs, purchase guarantees, tax credits, R&D support, and fully funding demonstration projects while the technology matures and competes with the conventional generation technologies. Before giving an investment decision, an accurate plant profitability assessment is essential, especially for OWFs due to the being highly dependent cost structure on site conditions, which results in higher capital and operational expenditures. Hence, OWFs have lower internal rate of return (IRR) and higher levelized cost of electricity (LCOE) compared to their on-shore counterparts. The feasibility analysis provides accurate inputs to the government and investors to help them develop regulatory policies and make viable investment decisions which helps to boost the offshore wind technology.

Feasibility analysis for OWFs yields estimations regarding capital and operational costs, including the net present value (NPV), payback period (PBP), LCoE, and IRR which are a true barometer of the power plant profitability assessment. Various feasibility analyses have been conducted for OWFs [9, 15, 16, 17, 18, 19, 20, 21]. Besides the scientific literature, the investor companies which are interested in developing large scale OWFs, perform detailed technical and financial feasibility studies before making investment decisions in their daily operations. Relying on consistent actual OWF real data, Dicorato et al. in [15] and Gonzalez in [20] derived formulas to evaluate the cost of OWF components as a function of installed wind power. Adopting the formulas, Kim et al. in [16] evaluated the investment cost and profitability of OWF development on the optimal site around the Korean Peninsula using a site selection analysis. In [20], the commodities (turbines, electric components etc.) price volatility was found to be the main factor affecting OWF economics. The volatility of global steel prices especially influences the overall cost of OWF projects. Specific software packages such as windPRO [22], and RETScreen [23] are commonly used by wind energy project developers and investors. The majority of investors developed their inhouse financial or economic analysis tools based on advanced Excel functions generated using Visual Basic. Researchers have also used similar programs such as windPRO and WindSim for techno-economic feasibility analyses of OWFs [17, 21]. The portion of electrical works such as the design and installation of underwater cabling, offshore or onshore substations, and other electrical equipment represents a considerable amount in terms of the investment costs of OWFs. Therefore, the need for proper electrical network design for OWFs is mandatory as the installed capacity increases. In [9], the various electrical system design schemes were compared in terms of the techno economic perspectives for an OWF of 1 GW in the northeast coast of Scotland. It was found that the star and radial design schemes are the most economical options while the ring design requires higher investment. Even if the ring design is superior in terms of redundancy and power losses, the economic concern is seen as a barrier to expand this design scheme in future large-scale OWFs.

Turkey is one of the key emerging countries in the G20. The energy demand is rapidly increasing due to its economic development and growing population. In terms of the total installed power capacity, it is in the top 6 countries in Europe and in the top 20 countries

in the world. As of 2016, the total electricity production and installed capacity are 261,783 GWh and 73 GW, respectively. Turkey is extremely dependent on natural gas imports especially for electric power generation. The total imported natural gas amount in 2014 was 1.7 billion cubic feet [1]. Since Turkey is an energy importing country, the aggressive pursuit of renewable energy resources becomes indispensable to reduce its dependence on oil and natural gas imports. Among all the renewable energy sources, wind energy is succeeding in Turkey thanks to its geographical location. As stated in [24], the estimated technical wind power potential of Turkey is 83 GW which ranks Turkey as the highest wind power potential country among the countries in the European Organization for Economic Co-operation and Development. The installed wind energy capacity increased 16 fold since 2008, reaching a total capacity of 6.1 GW as of the end of 2016 [4, 25]. The wind market is rapidly increasing in Turkey, which made it one of the top three countries in Europe and seventh in the world for wind power capacity addition in 2016 [5].

Turkey's energy policy have been shaped from experiences over the past decade. The Renewable Energy Law (No. 5346) was introduced in 2005 and revised several times to encourage and regulate wind power development [26]. Currently, the FiT of 7.3 cent/kWh is adopted for wind energy projects. An addition of up to 50% of the FiT can be included depending on what percentage of the components are domestic [27]. According to the amended law 6446, all renewable projects up to 1 MW are now exempt from getting licenses, while a pre-license and a full-generation license are required to build a renewable energy plant of over 1 MW [21]. Turkey set a target of installed wind power capacity of 20 GW by 2023 [28]. Meeting this goal requires the further use of the wind power potential. In this regard, the offshore wind potential can be an alternative since the country is surrounded by seas on three of its sides. Considering only wind speed and water depth of 50 m, Malkoc [29] roughly estimated the theoretical offshore wind power potential of Turkey to be 10.5 GW for the regions in wind classes higher than 4 m/s. Argin and Yerci in [30, 31, 32] performed multi-criteria site selection (MCSS) analysis to further investigate the potential of coastal regions of Turkey for OWF development. It is shown that some part of the Aegean and Marmara sea coasts (e.g., Canakkale, Gemlik, Datca) are not applicable due to restrictions imposed by technical, geographical, political, social, and civil issues, even though the regions have above average wind speed. The Bozcaada, Bandirma, Gokceada, Inebolu, and Samandag coastlines are found to be the most suitable locations for OWF development. It is found that the total estimated offshore wind power capacity at the specified sites is 1,629 MW. Currently, there has been no installed nor in operation OWF in Turkey. Any specific incentive for OWF initiatives has not yet been described in the current renewable energy regulation. Therefore, a thorough feasibility analysis is needed for OWF development in Turkey.

This study presents detailed techno-economic feasibility analysis of the most promising Turkish OWF locations. Taking an OWF owner's perspective, the study accounts for the key economic variables informing the decision making process. The main goal is to provide the most important measures such as NPV, LCOE, discounted payback period (DPBP), and IRR for the selected OWFs that highlights the conditions that must be met for their investments to be profitable. Potential offshore location constraints such as military zone, presence of infrastructures like pipelines etc., and other technical, geographical, social, and

civil issues do not allow use of the entire potential area. Therefore, the offshore sites are pre-determined by performing MCSS analysis [30, 31, 32]. An extensive feasibility analysis is conducted for three out of the most promising five Turkish OWF locations. Possible electric system design topologies are developed and compared in terms of OWF economics. Discounted cash flow analysis is then performed for current renewable energy supporting schemes under various discount rates.

The rest of this paper is organized as follows. Section II introduces the site selection criteria and the offshore sites studied. The proposed OWF system is described in Section III. The techno-economic feasibility analyses for selected offshore sites are evaluated in Section IV. Results and discussion are presented in Section V. Finally, Section VI provides the concluding remarks.

## 2. OWF Location Determination of Turkey Based on MCSS Analysis

### 2.1. Site selection criteria for Turkey

Site selection is key to the success of OWF projects both economically and technically. For this purpose, the primary investigation of restricted areas is required. Depending on the site properties, the perspectives may include, but are not limited to, oil and gas extraction, military exercise areas, underwater cables, harbor entrances and navigation routes, environmental restrictions, aquaculture, sand and gravel extraction, marine archaeology sites, landscape and seascape as public heritage, offshore energy projects already installed in the region of interest, and relevant characteristics of the site (e.g., water depth, distance to shore, distance to the operation and maintenance base, seabed geology, social and regulatory issues, safety) [33, 34]. Considering the conditions of seas in Turkey, several criteria are taken into consideration to assess the suitability of location for installing an OWF. It was found in [30, 31, 32] that an OWF location must be suitable primarily in terms of territorial waters, military areas, civil aviation, shipping routes, social and environmental concerns, and the presence of infrastructures such as pipelines and underground cables. Many other limitations such as the location of oil and gas platforms and mining zones are not applicable for Turkey. They are however generally considered in other countries in the identification of an OWF site.

In the preliminary study [30, 31, 32], the MCSS method has been used to identify the suitability of sites for OWF development in Turkey. After the initial assessment based on wind power density, eleven regions including Bozcaada, Amasra, Samandag, Gokceada, Inebolu, Canakkale, Bandirma, Gemlik, Datca, Aliaga, and Karasu were found to be suitable. Further implementation of the MCSS method revealed that Amasra cannot be considered for OWF development due to restricted military training zones in spite of its high wind speed density. Canakkale, Datca, and Gemlik have many restrictions that do not meet all site selection criteria. Aliaga also does not appear to be suitable due to a military special security zone and heavy maritime traffic. Karasu, on the other hand, has lower wind speeds which would not be feasible for OWFs. Bozcaada, Bandirma, Gokceada, Inebolu, and Samandag were found to be the most suitable locations for OWF development in Turkey.



Figure 1: Proposed OWF in Bozcaada (Adapted from Google Maps).

To maximize the economic feasibility of the suitable OWF sites, micro-sitting of turbines is conducted based on four major criteria; wind direction, sea depth, distance to shore, and turbine spacing. To maximize wind energy usage, turbines are deployed perpendicular to the main wind direction in each location. Also, to reduce wake effects, turbines are distributed in rows spacing 4.7 rotor diameters ( $D$ ) within each row and 9.3  $D$  between rows, which are within the limits as recommended in [35]. Siemens turbines with a rated power of 3.6 MW and a rotor diameter of 107 m [36] are assumed to be used in the proposed OWF.

## 2.2. Site Description

### 2.2.1. Bozcaada

Bozcaada is one of the largest islands of Turkey located in the Aegean Sea. Although the island has one of the highest mean wind speeds in Turkey [30, 31], it includes only one onshore wind farm. The existing wind farm with a capacity of 10.2 MW is located on the west side of the island [37]. To capture the maximum amount of energy from the wind, turbines are placed on the north and northwest side of the island as the main wind direction in Bozcaada is from northeast to southwest as shown in Fig. 1. The shallowest parts of the sea up to a sea depth of 45 m are considered for turbine sitting, since foundation costs significantly increase with sea depth. No turbines are considered on the south of the island due to the proximity of the possible turbine sites to the shore within a sea depth of 45 m as the hills on the island appear to reduce the wind speed significantly. The suitable site in Bozcaada is limited by Greek territorial waters on the west and a military restricted area on the north. Thus, the total number of 223 turbines with a power capacity of 802.8 MW can be sat in the determined site. The generated offshore wind power is collected at an

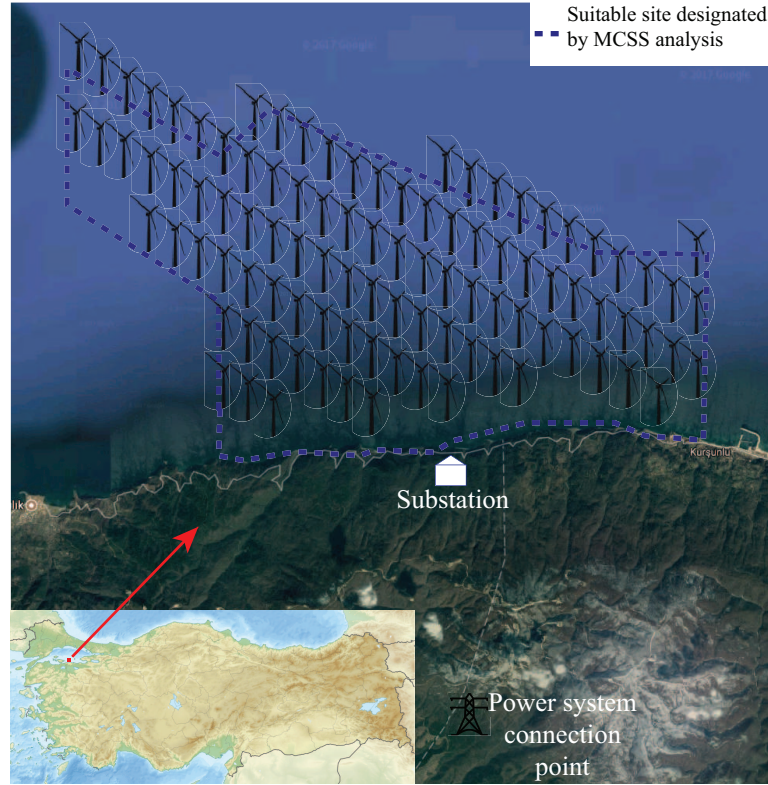

Figure 2: Proposed OWF in Bandirma (Adapted from Google Maps).

onshore substation and transmitted to the mainland through high voltage underground and overhead lines since there is not any high voltage transmission line on the island.

### 2.2.2. Bandirma

Bandirma is located by the Marmara Sea, which is an interior sea on the western part of Turkey. The location accommodates a considerable number of onshore wind farms with the total installed capacity of 359.4 MW [37] thanks to its high wind power density. Bandirma shores are only restricted by military areas which are located on the northeast side of Bandirma, but, this is far away from any possible OWF site. The part of the sea in the selected site is relatively deeper as compared to its Bozcaada and Gokceada counterparts. Similar to the Bozcaada OWF, turbines are placed up to a sea depth of 45 m in accordance with the main wind direction in the area. The total number of 97 turbines with a power capacity of 349.2 MW can then be placed in the determined site as shown in Fig. 2. The generated offshore wind power is collected at an onshore substation and transmitted to the power system through a high voltage overhead line of 3.5 km.

### 2.2.3. Gokceada

Gokceada is the largest island of Turkey and located north of the Aegean Sea and west of Canakkale. There is currently no onshore wind farm installed in Gokceada. The part of the sea surrounding the island is deeper than the considered 45 m sea depth. Thus, a relatively





Figure 3: Proposed OWF in Gokceada (Adapted from Google Maps).

small site on the east shores of the island can be appropriate for installing any OWF. The area is also the closest location to the mainland in Turkey. The area is restricted by a military zone on the north-east side and a diving zone on the south-west side of the island. The selected site can then host 74 turbines with a maximum power capacity of 266.4 MW (Fig. 3). There is currently no high voltage transmission line on the island. The generated offshore wind power is therefore collected at an onshore substation and transmitted to the bulk system on the mainland through a high voltage underground cable and overhead lines. The existing underground cable between the island and the mainland is limited to carry 90 MW, thus, it cannot carry the proposed 266.4 MW of power.

### 3. OWF System Description

The general layout of the OWF configuration designed in the study is illustrated in Fig. 4. The proposed OWF consists of a number of turbines, an onshore substation, an inner collection system, and transmission lines at medium and high voltages between the turbines and the Turkish transmission system. The location of onshore substations is chosen to minimize the overall line cost and power losses. The proper electrical collection system design is crucial especially for large-scale OWFs as the efficiency, reliability, and overall performance of the system depend greatly on the electrical system design. Three design schemes (e.g., radial, ring, and star designs) have been typically employed in existing OWFs [15]. A group of turbines is sat on a single line in a radial design, while turbines are

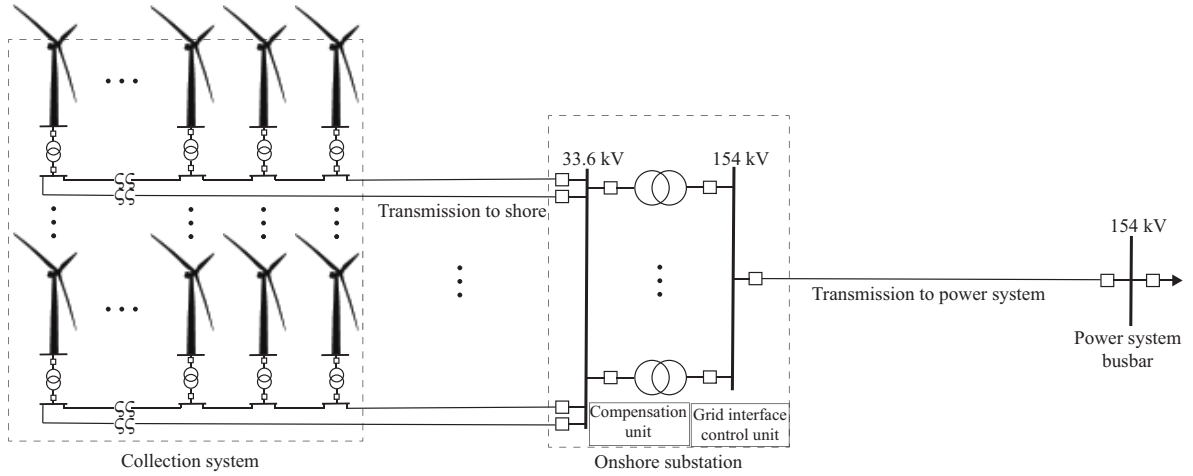

Figure 4: General layout of the proposed OWF configuration.

distributed over each separated line in a star design. The ring design, on the other hand, includes an additional line by establishing a closed loop circuit between turbines to provide more redundancy in case of a fault. It is reported in [9] that the ring design provided lower power losses compared to radial and star designs. However, it requires higher investment costs while the investment cost of the star design remains almost the same as a typical radial design. The cost and power losses depend to a large extent on the geographic layout of the OWF site, and hence the sitting of turbines and the total length of cabling. In this study, the three design scheme are analyzed and compared in terms of economics to find the economically optimal design for the selected locations. In each design scheme, a different number of turbine arrangements were used after investigating the effect of the turbines' sittings.

An onshore substation is considered since the length of the collection system for the turbines which are the closest to shore is relatively short, varying from 150 meters to 335 meters in each studied location. The offshore voltage level within the collection system and from the collection system to the onshore substation is 33.6 kV. Step-up transformers rated 0.69 kV/33.6 kV, 6.25 MVA at each wind turbine are used to increase the voltage level, thereby reducing power losses within the collection system and from the collection system to shore. The transformers are supplied within turbine units. That's why the cost of these transformers will be considered in the turbine cost. The onshore substations in each site are connected to the closest node of the power system through a high voltage transmission line. Since the existing transmission line in the power system is at 154 kV, the step-up transformers rated 33.6/154 kV, 100 MVA are used in the substation. The length and ratings of the cable differ in each examined location depending on the total power capacity and the sitting of the turbines. It is also considered that the onshore substation includes necessary compensation devices (shunt reactors or Static VAR compensator), and an OWF monitoring system (namely SCADA) along with a communication line.

#### 4. Techno-economic Analysis

NPV, LCoE, DPBP, and IRR are the major investment indicators which help the power plant project developers make their investment decisions. Each indicator provides a unique information about the cash flow. The investors evaluate all indicators in an integral way before taking the final decision, since one indicator alone cannot exhibit the entire investment dynamics. NPV represents the deviation between the present value of annual cash inflows (benefits) and the present value of annual outflows (expenditures). For the entire project lifespan of an OWF, NPV can be expressed by:

$$NPV = -C_{CAPEX} + \sum_{t=1}^T \frac{netCashFlow(t)}{(1+r)^t} \quad (1)$$

where,  $C_{CAPEX}$  and  $T$  are the total capital expenditure cost and lifespan of the OWF, respectively, and  $r$  is the annual discount rate. The net cash flow for a year is found by subtracting the net present value of outflows from the net present value of annual cash inflows. The outflows correspond to the operational expenditures in the corresponding year while the inflows are related to the AEP of the corresponding year. A financial option for the investigated power plant becomes economically viable for the positive NPV values. The LCOE is a special per unit cost measure which represents the net present value of the power plant over its lifetime and is calculated by:

$$LCOE = \frac{\sum_{t=0}^T \frac{C_{CAPEX}(t)+C_{OPEX}(t)}{(1+r)^t}}{\sum_{t=0}^T \frac{netAEP}{(1+r)^t}} \quad (2)$$

where,  $\forall t \in \{1..T\}$   $C_{CAPEX}(t) = 0$  and  $C_{OPEX}(0) = 0$ .  $C_{OPEX}(t)$  is the operational expenditure for the year of  $t$ . The net AEP is the estimated amount of energy yielded by the plant for one year. The PBP refers to the length of time that it takes for the cumulative profit to equal the cumulative cost. However, the PBP does not consider the time value of money. Therefore, using the PBP would be misleading when the discount rate is greater than zero percent. In this case, it is essential to use the DPBP value where the time value of money is also considered. The DPBP is then expressed by Eq. 3 [38].

$$DPBP = \frac{\ln\left(\frac{1}{1-\frac{r \cdot C_{CAPEX}}{NetCashFlow}}\right)}{\ln(1+r)}. \quad (3)$$

On the other hand, the IRR measures the profitability. It refers to the discount rate which makes the NPV of the OWF equal to zero. The IRR is found by dividing the net profit of the OWF by the total cost of the OWF. To determine the economic indicators, the total cost of the OWF is first calculated which consists of capital and operational expenditures. Capital Expenditure (CAPEX) is the cost to purchase, install, and decommission the plant while operational Expenditures (OPEX) refers to the recurring costs of operating and maintaining the plant. Secondly, the net AEP is estimated based on the technical specifications of the

plant such as capacity factor and electrical losses. The final step includes the calculation of the revenue derived from sale of the energy. Financial parameters such as available FiT, discount rate, and operational lifespan of the plant are taken into consideration in this calculation.

#### 4.1. CAPEX

The CAPEX of an OWF typically can be broken down into four parts [20]: (i) the turbine cost, (ii) the support system cost, (iii) the electrical system cost, (iv) project development and management costs including other costs like insurance.

##### 4.1.1. Wind Turbine Cost

Based on the installed wind power capacity, [15] formulated the turbine cost for turbines ranging from 2 to 5 MW. The overall turbine cost including transportation and installation, which are considered to be 10% of turbine cost, is given by

$$C_{turbines} = 3.245 \cdot 10^3 \ln(P) - 412.72 \quad [k\text{€}] \quad (4)$$

where,  $P$  is the installed wind power capacity.

##### 4.1.2. Support System Cost

The support system (foundation and tower) cost includes manufacturing, transportation, and installation costs. The total cost of transportation and installation of the support system is assumed to be 50% of the manufacturing cost of the overall system. It can be formulated by Eq. 5 in [15].

$$C_{support} = 480 \cdot P(1 + 0.02(d - 8))(1 + 0.8 \cdot 10^{-6}(h(\frac{D}{2})^2 - 10^5)) \quad [k\text{€}/turbine] \quad (5)$$

where,  $d$  [m] is sea depth,  $h$  [m] is hub height and  $D$  [m] is rotor diameter. In the support system cost calculation, monopile foundation cost is considered for all the wind turbines that are installed up to a sea depth of 45 m, and soil properties are not explicitly considered since there is no publicly available data in Turkey.

##### 4.1.3. Electrical System Design and Cost

The electrical system of an OWF comprises of various components which are crucial for system design as well as power transmission efficiency. The cost of the electrical system varies within a wide range, typically from 10% to 30%, depending on various parameters such as the position of the wind turbines, their distance to shore, and the total installed wind power capacity [39],[40], [41], [42], [43]. In this study, the electrical system cost of components include the inner cable, the substation, power factor correction devices, and high voltage cables connecting the plant to the nearest power system connection point.

*4.1.3.1 Collection System:* The power generated by the wind turbines is delivered to the onshore substations using submarine cables at medium and high voltages. Special insulation is required around the cable conductor since the cables are subject to the sea environment,

therefore, cross-linked polyethylene (XLPE) cables are considered for cabling. The most common cable type used for inner cable installations is 3-core XLPE cable [39, 44]. The cost of cables usually changes per unit length, however, since the conductor size is different throughout the system, careful cost calculation is needed [15]. In addition, cable installment and burying costs are considered part of the collection system cost.

Various methods of cost calculations for XLPE cables are presented in the literature [15, 20, 39, 44]. In this study, the cable costs presented in [15] are used. The cables are selected from one of the manufacturer's data sheets [45] considering the available cross sections and their current ratings. The cable cross sections used in wind turbine connections are calculated from the wind turbine power rating and system voltage level.

$$C_{cable/km} = \alpha + \beta \times e^{\frac{\gamma \cdot I_n}{10^5}} \quad [k\text{€}/km], \quad (6)$$

where,  $I_n$  represents cable ampacity,  $\gamma=234.34$ ,  $\beta=75.51$ , and  $\alpha=52.08$  are coefficients for the different cable voltage levels. The cable length used to connect the wind turbines to the substation depends on the electrical layout, namely, the collection system. Using engineering judgments, four different configurations are considered for each proposed OWF; two radial and two star configurations, in addition, one ring design is considered for Bandirma only. The number of turbines, varying from 4 to 13, that each feeder can hold depends on the physical layout. The cables at each feeder are selected based on the total current flowing out of the turbines. The minimum of 4 turbines is decided considering the cable cross section that can carry the maximum number of turbines. A maximum of 13 wind turbines is determined by considering the maximum 3 core XLPE cable current capacity. To connect more than 13 turbines in one feeder, three single core cables with a higher cost are needed. As expected, the cost of the ring configuration is higher than the radial and star configurations, however, it is very close to one of the star configurations. Therefore, proper layout design including the reliability concerns should be considered to develop feasible OWFs. Fig. 5, Fig. 6, and Fig. 7 show the most economical layouts of each design scheme for the proposed projects.

The resulting inner cable cost is calculated by:

$$C_{cable} = C_{cable/km} \times l_{inner-cable} \quad [k\text{€}] \quad (7)$$

The total length includes an additional 40 m cable for each turbine as supplementary cable extension, as recommended in [20]. To find the most economical layout, developed configurations are compared in terms of their cost. The radial design has been found to be the most economical for each proposed OWF project. Table 1 provides the details of the layout and mean length of the inner cables.

Cables collecting the power from wind turbines and delivering to the onshore substation go under the sea. It is highly recommended to bury them since it is more secure and saves the cables from possible external damages [20]. Different prices are presented in [15, 20, 40] as burying costs. The constant cost of 273 k€/km given in [40] is used in this study. The total burying cost for a length  $l_{inner-cable}$  [km] is calculated as:

$$C_{burying} = 273 \times l_{inner-cable} \quad [k\text{€}] \quad (8)$$

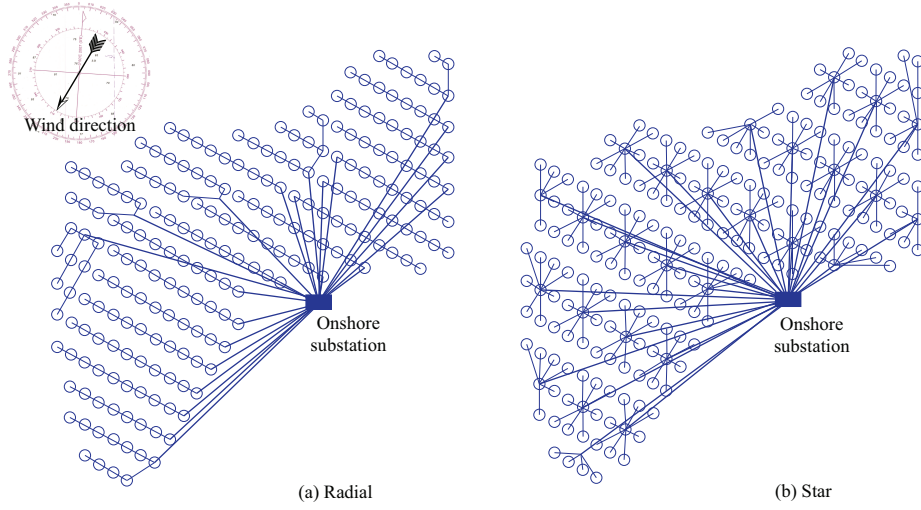

Figure 5: Proposed OWF layouts in Bozcaada.

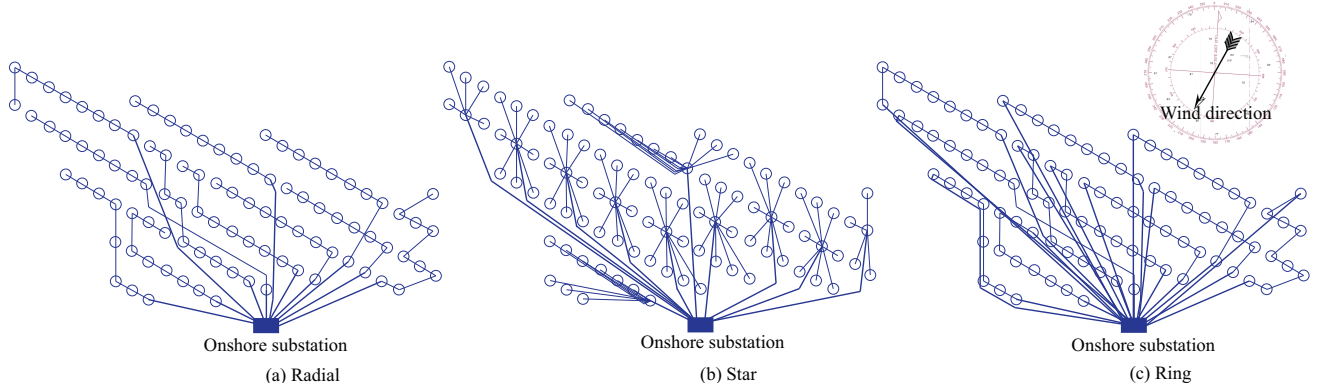

Figure 6: Proposed OWF layouts in Bandirma.

*4.1.3.2 Onshore substation cost:* Main cost components of the substation are transformers, high voltage busbar and switchgears, and backup generators. Since there are more cost components than the above mentioned ones, the substation cost is considered as a lump sum that is a function of the installed wind power capacity. Different substation costs per MW are provided in [20] and a cost of 50 k€/MW is used for the calculations. Power factor correction devices located at substations such as shunt reactors, static VAR compensators (SVC), and STATCOMs are required to increase the efficiency specifically when underground cables are used. The cost models in [20] are used for each components as follows:

$$\begin{cases} C_{shunt-reactor} = 2,556 \text{ €/}MVAr \\ C_{SVC} = 6390 \text{ €} + 63,900 \text{ €/}MVAr \\ C_{STATCOM} = 128 \text{ k€/}MVAr \end{cases} \quad (9)$$

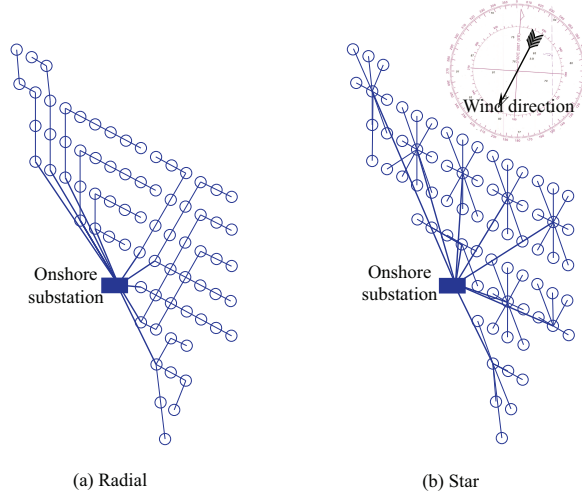

Figure 7: Proposed OWF layouts in Gokceada.

Thus, the total substation cost is found by:

$$C_{substation} = 50[k\text{€}]/MW + C_{shunt-reactor} + C_{SVC} + C_{STATCOM} \quad (10)$$

*4.1.3.3 Transmission line cost:* The inner cables collect the generated power from each wind turbine and delivers the power to the onshore substation. The type of the transmission line (underground cable or overhead line) depends on the studied location that the line goes through. This selection noticeably affects the total cost of the transmission line. The underground cables used for sea and land are both XLPE type, however, their cost and installation costs are different. On the other hand, the overhead line cost also depends on the number of circuits and voltage levels. Different costs are available in the literature for high voltage transmission line installations. Costs presented in [15] are selected and used for the calculations. The length of both the underground and overhead lines used in studied locations are presented in Table 1. Total transmission line cost is calculated by:

$$C_{transmission} = C_{underground/km} \times l_{underground} + C_{overhead/km} \times l_{overhead}. \quad (11)$$

*4.1.3.4 Grid connection cost:* In this study, the grid connection cost is considered as a part of the project cost. The cost as a function of installed wind power [20] is calculated as:

$$C_{GC} = 8.047 \times P^{1.66} \quad (12)$$

#### 4.1.4. Project Development, Management and Other Costs

The project development, management and the other costs such as construction phase insurances, engineering and design costs are estimated to be \$280.38 per MW based on [41, 46].

Table 1: The key parameters of the proposed OWFs for the most suitable locations of Turkey based on multi-criteria selection analysis.

Components	Bozcaada	Bandirma	Gokceada
<b>Turbine</b>			
Rated Power (MW)	3.6	3.6	3.6
Number of turbines	223	97	74
Hub Height (m)	93	93	93
Rotor Diameter (m)	107	107	107
Output Voltage (V)	690	690	690
<b>Inner cables</b>			
Type	XLPE(3 core)	XLPE(3 core)	XLPE(3 core)
Size (mm <sup>2</sup> )	95 - 800 (radial)	300 - 400 (radial)	95 - 1000 (radial)
	95 - 400 (star)	150 - 630 (star& Ring)	185 - 400 (star)
Voltage (kV)	33.6	33.6	33.6
<b>Substation</b>			
Transformer (MVA)	100	100	100
Voltage (kV)	33.6/154	33.6/154	33.6/154
<b>Transmission Line</b>			
Underground (km)	7.5	-	17.3
Overhead (km)	7.5	3.5	1.7
Voltage (kV)	154	154	154

#### 4.2. OPEX

The OPEX of an OWF covers the operational and maintenance costs (O&M costs) of the plant, including other cost components such as administrative costs, insurance premiums, and royalties. The OPEX is estimated to be 1.9% of the total CAPEX per annum for 20 years lifespan of the project [16]. The total investment cost of an OWF is thus expressed as follow:

$$C_{CAPEX} = C_{turbines} + C_{support} + C_{cable} + C_{burrying} + C_{substation} + C_{transmission} + C_{GC}. \quad (13)$$

The aforementioned cost models regarding CAPEX cost components based on [15] was referred to euros. The economic calculations in this study, are performed in terms of US dollars. The dollar/euro parity of 1.335 is used to convert the CAPEX values to the US dollars.

#### 4.3. Annual Energy Production and Revenues

AEP values are calculated using an open source renewable energy sources analysis tool named the Virtual Wind Farm (VWF) model [47]. The tool uses the weather data from



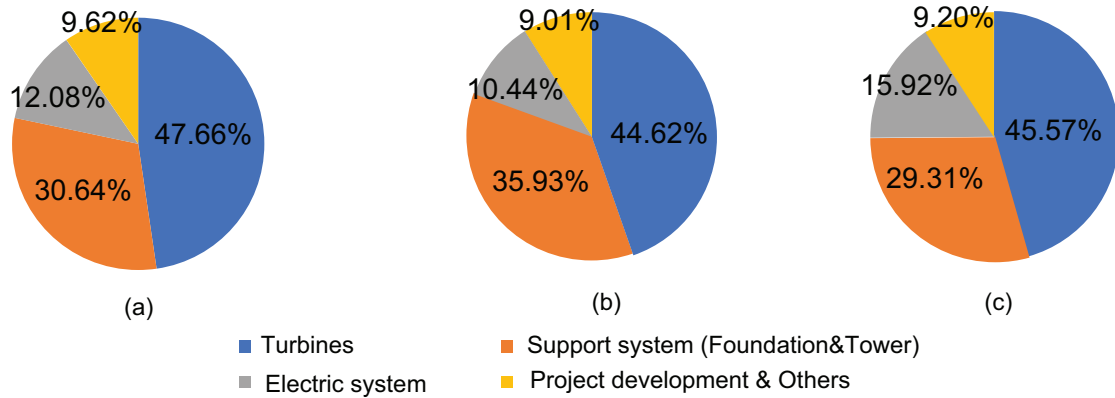

Figure 8: The breakdown of CAPEX cost per kW a) Bozcaada OWF b) Bandirma OWF c) Gokceada OWF.

satellite observations and global reanalysis models such as NASA’s MERRA (Modern-Era Retrospective Analysis for Research and Applications). Wind power output values are generated from wind speeds using the VWF model by [48]. The VWF model estimates the AEP values without considering array, electrical, and other related losses. Therefore, a reasonable park efficiency factor of 95% is used to estimate the net AEP value. The net AEP is calculated by subtracting wake effects (2%) and electrical cable losses (3%) from the gross AEP estimated by the VWF model. Annual revenues are estimated by multiplying the net AEP and the corresponding FiT.

## 5. Results and Discussion

An economic feasibility study of three OWFs has been conducted for Turkey’s available renewable energy support schemes under various discount rates. In accordance with the available support scheme, two FiT values are studied. Initially, the base FiT of 7.3 \$/kWh is used which corresponds to the case where all the electro-mechanical OWF components are exported. The second case, on the other hand, considers the a maximum FiT of 11 \$/kWh which corresponds to the case where all the electro-mechanical OWF components are manufactured domestically in Turkey. The project lifespan of proposed OWFs is assumed to be 20 years. In addition, 6%, 8%, and 10 % discount rates are considered to perform the financial sensitivity analysis. Taxation and inflation rates are ignored in this study. Results are shown as (i) best case scenario based on the lowest discount rate (6%), CAPEX & OPEX values, and highest support scheme (e.g., max. FiT) (ii) worst case scenario based on the highest discount rate (10%), CAPEX & OPEX values, and lowest support scheme (e.g., base FiT).

**CAPEX & OPEX Values:** The calculated CAPEX and OPEX components are summarized in Table 2. The radial design is the most economical for all OWFs. Between radial and star designs in Bozcaada and Gokceada OWFs, the star design results in higher CAPEX and OPEX. However, the ring design is the least economical among the designed electric system layouts for the Bandirma OWF.

Table 2: The CAPEX and OPEX costs of the proposed OWFs for the most suitable locations in Turkey based on multi-criteria selection analysis.

	<b>Bozcaada</b>		<b>Bandirma</b>			<b>Gokceada</b>	
	Radial	Star	Radial	Star	Ring	Radial	Star
<b>Total CAPEX (million \$)</b>	2,338	2,435	1,086	1,122	1,141	811	829
<b>CAPEX (million \$/kW)</b>	2,913	3,033	3,111	3,2145	3,268	3,046	3,115
<b>OPEX (million \$/year)</b>	44.4	46.3	20.6	21.3	21.7	15.4	15.8

As expected, in accordance with the total installed wind power capacity level, the highest total CAPEX values are estimated for Bozcaada OWF to be approximately \$2.43 billion where the optimal electric design reduces its CAPEX by 4.1%. As compared to the Gokceada counterpart, the per kW CAPEX for the Bandirma OWF is higher even though its electrical system cost is less. One reason is the higher support system cost as the average sea depth of the selected site in Bandirma is almost two-fold higher than that of Gokceada. The per kW foundation costs are calculated as \$1.118 million (35.93%) and \$892.8 million (29.31%) for Bandirma and Gokceada OWFs respectively. The per kW costs of turbine and project development for each project are the same which are estimated to be \$1.388 million and \$280,380 per kW respectively. The breakdown of CAPEX components' cost per kW is shown in Fig. 8. The total electrical system costs of the three projects form 10% to 16% of the total CAPEX costs which is in the lower range as compared to their counterparts presented in [39, 40, 41, 42, 43]. This is mainly due to two reasons: (i) the distances of the wind turbines to shore are relatively shorter, (ii) the use of lower-cost onshore substations for each location is only considered. In accordance with the total installed wind power capacity, the annual OPEX values range from \$15.4 million to \$44.4 million for Gokceada and Bozcaada OWFs respectively.

**Annual Energy Production and Revenues:** The estimated annual revenues, capacity factors and net AEP values for the three OWFs are summarized in Table 3. The capacity factors of  $\sim 43\%$  for Bozcaada and Gokceada are found to be almost the same, while the least capacity factor of  $\sim 37\%$  is estimated for Bandirma. Based on the corresponding capacity factor and installed power capacity, the highest net AEP value is found to be 3,034,293 kWh per year for Bozcaada OWF while relatively close net AEP values are calculated for the proposed Bandirma and Gokceada OWFs. This is due to the Bandirma OWF's higher installed capacity even though its capacity factor is lower as compared to the Gokceada counterpart. Depending on the net AEP values, the annual revenues for the base FiT range from \$73.8 million to \$221.5 million, while the revenues for the maximum FiT are found to be between \$111.2 million and \$333.8 million for the Gokceada and Bozcaada OWFs respectively. The annual revenue for Gokceada OWF is less even though its capacity factor is higher as compared its Bandirma counterpart. This is due to the restrictions of the selected site in Gokceada, which in turn, result in sitting a relatively less number of turbines.

**NPV, LCoE, DPBP, and IRR values:** The projected NPV and LCOE values

Table 3: Annual energy production and revenues of the proposed OWFs for the most suitable locations in Turkey based on multi-criteria selection analysis.

	Bozcaada	Bandirma	Gokceada
Capacity Factor (%)	43.14	37.45	43.33
Mean Wind Speed (m/s)	8.586	7.843	8.631
Net AEP (MWh/annum)	3,034,293,061	1,145,635,314	1,010,655,585
Annual Revenue with base FiT (million \$)	221.5	83.6	73.8
Annual Revenue with max FiT (million \$)	333.8	126	111.2

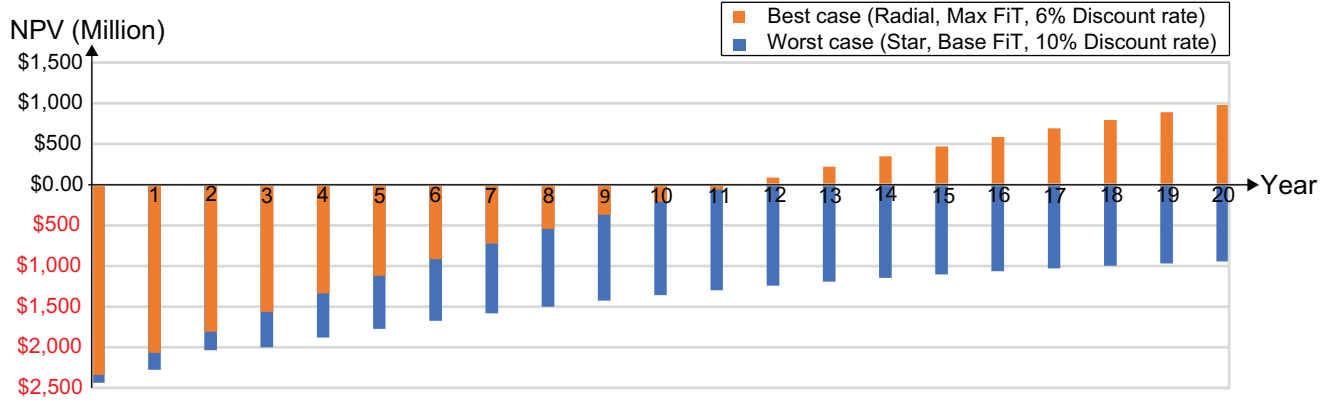

Figure 9: The discounted cash flow of Bozcaada OWF in terms of years for both scenarios.

under best and worst case scenarios for the three OWF projects are summarized in Table 4. The NPV of Bozcaada OWF under the best case scenario has a positive value of \$979,948,612 making it economically feasible. The lowest LCOE is estimated to be \$81.85 per MWh for the Bozcaada OWF for the best case scenario. However, under the worst case scenario, the project yields negative NPV values, which results in an infeasible option. The discounted cash flow for Bozcaada OWF over the project lifespan is demonstrated in Fig. 9. The DPBP value can be observed at the point where the NPV starts to have a positive value over 20 years. The DPBP value for the best case is estimated to be 11.3 years. The NPV never reaches the positive value under the worst case scenario, thus no valid DPBP value exists. The variation of NPV in terms of discount rates for both scenarios is demonstrated in Fig. 12(a). The best case remains economically viable for up to the IRR value of 10.77%. Beyond this point, NPV values become negative and as a result the project becomes unfavorable. The infeasible worst case scenario option is economically viable, if and only if, the discount rate is below 3.75%.

As reported in Table 4, the best NPV for the Bandirma OWF can reach \$122,040,296 at the end of its lifespan. It can be said that the Bandirma OWF project is economically feasible under the best case conditions, while the worst case still results in an infeasible option. The LCOE of \$100.73 per MWh calculated for the Bandirma OWF under the best-case scenario is the highest LCoE among proposed OWFs. The distribution of the net discounted cash flow

Table 4: NPV and LCOE values of the proposed OWFs for the most suitable locations in Turkey based on multi-criteria selection analysis.

	Bozcaada	Bandirma	Gokceada
Best NPV (\$)	979,948,612	122,040,296	286,727,729
Best LCOE (\$/MWh)	81.85	100.73	85.28
Worst NPV (\$)	-943,386,797	-613,814,651	-336,073,965
Worst LCOE (\$/MWh)	109.55	135.97	112.09

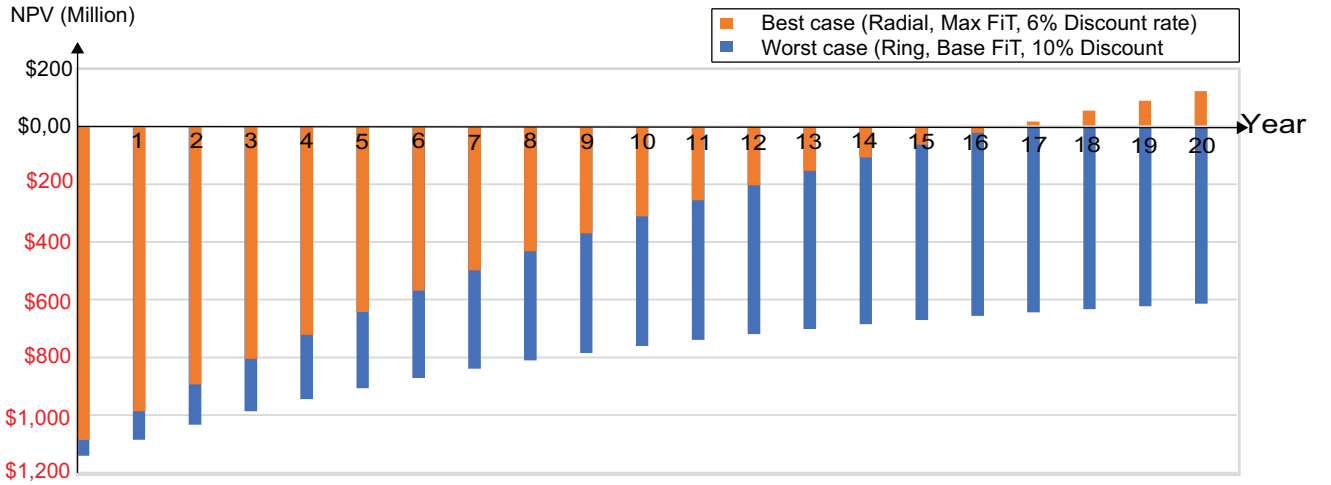

Figure 10: The discounted cash flow of Bandirma OWF in terms of years for both scenarios.

for the Bandirma OWF over its lifespan is shown in Fig. 10. The DPBP is estimated to be 16.5 years for the best case condition. There will be no DPBP for the worst case condition. The estimated IRR for the Bandirma OWF is shown in Fig. 12(b). The marginal IRR values are estimated to be 0.8 and 7.35 for the worst and best case scenarios, respectively. It can be concluded that to have an economically viable project under worst case conditions, the discount rate should be equal to or lower than 0.8%. Also, under the best case scenario conditions, the project becomes infeasible beyond the discount rate of 7.35%.

Gokceada OWF has NPV values ranging from \$286,727,729 to -\$336,073,965 for the best and worst case scenarios, respectively. It has the second lowest LCOE among the three OWFs. The discounted cash flow of Gokceada OWF is shown in Fig. 11. Similar to Bozcaada and Bandirma counterparts, the Gokceada OWF project is economically feasible under the best case while infeasible under the worst case conditions. The DPBP value for the best case is estimated to be 12.1 years. As shown in Fig. 12(c), under the best case scenario conditions, the Gokceada OWF project always remains feasible for the studied discount rates. The marginal IRR values are estimated to be 3.44% and 10.07% for the worst and best cases, respectively. The infeasible worst case option is economically viable, if and only if the discount rate value is below 3.43%.

**Discussion:** The OWFs in Bozcaada and Gokceada are located in relatively shallow

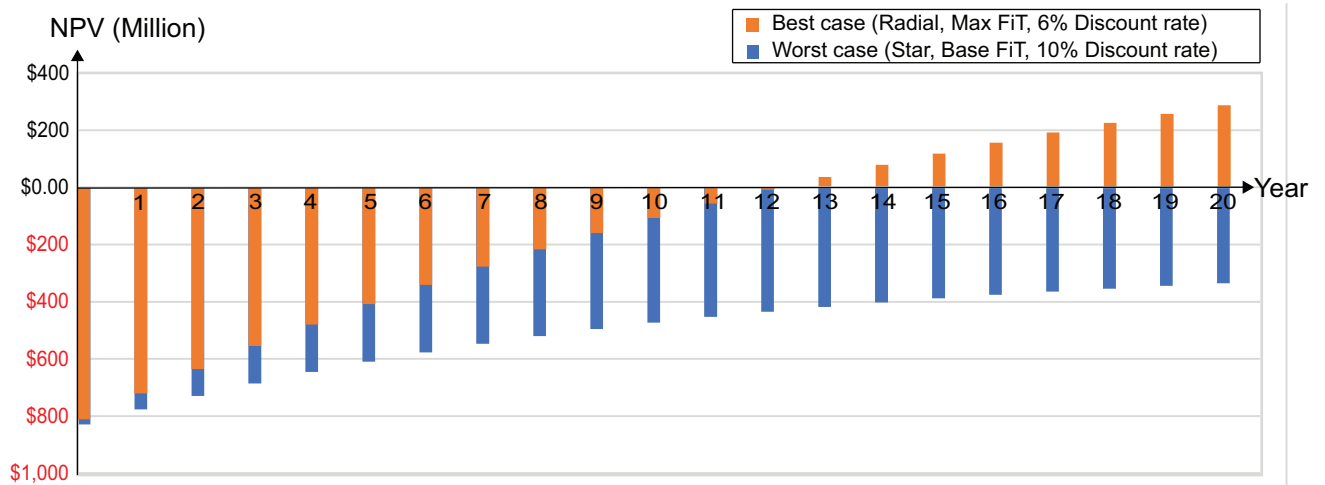

Figure 11: The discounted cash flow of Gokceada OWF in terms of years for both scenarios

water ( $\sim 20$  m) while Bandirma OWF is located in deeper area ( $\sim 40$  m). All investigated OWFs are relatively close to the shore. The average wind speed values varies between 7.843 to 8.631 m/s which yields capacity factors (CFs) between 37.45% and 43.33%. The CF values higher than 40% are considered to be high energetic offshore wind locations.

CAPEX is the major factor in calculating NPV and LCOE metrics. The estimated total CAPEX values range from 2,913 to 3,268 Million \$/kW for the Bozcaada and Bandirma OWF projects respectively. The estimated CAPEX values correlate with the ones in the literature [15, 49]. CAPEX might reach up to 5,900 million \$/kW in most of the UK OWFs. However, these OWFs include offshore substation and higher energy transmission costs due to larger water depths and longer distances to the shore.

Similar results can be seen for LCOE levels. The estimated LCOE values for the investigated OWFs range from \$81.85 to \$135.97 per MWh depending on their CAPEX, OPEX, revenues and other financial assumptions. In this study, taxation is ignored. If we consider 15% income tax, the lowest LCOE can increase up to \$96 per MWh. In [49], the LCOEs are estimated to be \$95 and \$167 per MWh for Horns Rev III and East Angalia OWFs respectively. In this study, inflation rate, taxes, 10% contingency and the use of offshore substation parameters are not included in calculating LCOE values. Thus, the estimated LCOE values tend to be more moderate in comparison to the ones which are built in deeper waters and far away from the shore.

As compared to the Gokceada counterpart, the Bozcaada OWF has a higher net NPV due to the sitting of more turbines and the more closer to the mainland, which in turn make the location more favorable. This shows why the MCSS analysis is needed before installing OWFs. The Bandirma has on the other hand, a lower capacity factor and a higher CAPEX value. Among the possible three locations, installing an OWF in Bandirma is therefore not pronounced.

Higher discount rates, lower FiT, and higher CAPEX values made investigated OWFs economically infeasible. However, in case of meeting the best case scenario conditions, all

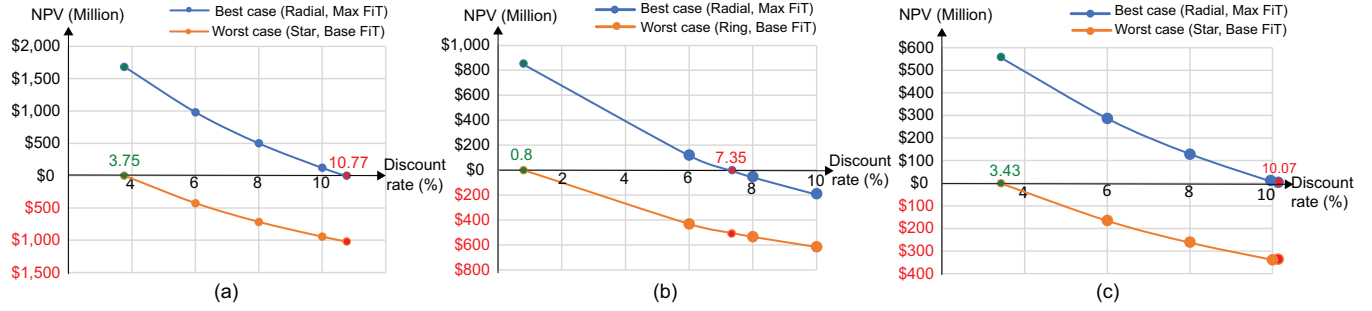

Figure 12: The variation of NPV in terms of discount rates for both scenarios a) Bozcaada OWF, b) Bandirma OWF, c) Gokceada OWF.

OWFs become economically feasible. Relatively short DPBP values are estimated for the Bozcaada and Gokceada OWF projects, that are 11.3 and 12.1 years for the best case scenario respectively. The highest DPBP of 16.5 years is estimated for the Bandirma OWF project. Under the worst case conditions, DPBP values for a 10% discount rate will be beyond the lifetime of the OWFs, thus making all three projects economically unfeasible.

The IRR values for best case scenario are estimated to be 10.77%, 7.35%, and 10.07% for Bozcaada, Bandirma, and Gokceada OWF projects respectively. That shows that these projects are economically viable when the discount rates are kept below the corresponding IRR values. Under the best case conditions, the highest IRR is 10.77% in which all OWF projects are economically infeasible beyond this rate. In contrary to this, all OWF projects under the worst case scenario conditions can be feasible only with the lowest IRR of 0.8%.

## 6. Conclusion

In this paper, techno-economic feasibility analysis has been conducted for OWF projects located in three of the most promising Turkish high potential wind locations. First, three locations are selected from a MCSS analysis in the earlier study. Second, the overall costs of the proposed OWFs have been calculated by algebraic formulations derived from actual OWF real data in the literature. After the most economical electrical system layouts were found, the net AEPs have been estimated using the VWF model. Finally, discounted cash flow analysis has been performed for current renewable energy supporting schemes under various discount rates. The analysis yields the following conclusions:

- As being an investment decision making criterion, NPV depends on various techno-economic parameters. The proposed OWF projects are therefore economically feasible if and only if specific conditions such as certain FiT, discount rates, and location specific characteristics are met.
- Among all possible electric system layouts, the radial design is the most economical for proposed OWF projects.
- Installing an OWF in Bozcaada is the best investment option while in Bandirma is the worst of the three studied locations.

- Even though Gokceada has the highest technical wind power capacity, its economics are less as compared to the Bozcaada counterpart since the available offshore site in the location is far from the mainland which increases its electrical system investment cost.
- An OWF investment-specific FiP mechanism shall be created in Turkey in which the FiP rates are defined based on OWF site conditions.
- In order to encourage and support OWF installations in Turkey, the discount rates and FiT rates need to be adjusted such that the domestic manufacturing is increased and the return of investment times are shortened.
- Hence, development of financial incentives using publicly owned funds will increase the economic attractiveness of large-scale OWFs. A flexible financial support model can be employed with lower discount rate and a payback period of 20 years depending on capacity factor and physical characteristics of OWFs such as water depth and distance to shore.
- The existing FiT for the wind energy projects is paid for in the initial 10 years. The DPBP values have been found to be greater than 10 years even for the most feasible OWF project options. Therefore, there are still higher uncertainties beyond 10 years for possible OWFs in Turkey.
- Turkish government applies discounted tax brackets for the electrical energy power plant in Turkey (e.g., 15% instead 20%). Development of a new tax structure with lower tax percentages or tax credit type of mechanisms can increase the economic competitiveness of OWF projects in Turkey.
- Under current conditions, the LCOE for offshore wind power generation is not reaching the grid parity in Turkey. The electricity market prices are volatile and mostly dependant on the oil price fluctuations. The LCOE is expected to be lower with next generation high efficient wind turbines and innovative foundation systems. Thus, OWF development may reach the grid parity in the future which makes this technology economically viable even without any support mechanism.

The presented study can be further extended with detailed risk and variance analysis methods which also consider the future development of techno-economic components, depreciation charges and tax rates.

## 7. References

- [1] International Energy Agency (IEA), Energy supply security emergency response of IEA countries (2014). URL [www.iea.org](http://www.iea.org)
- [2] Paul Arwas, et al., Offshore wind cost reduction pathways study, The Crown Estate (2012) 1–88. URL <https://www.thecrownestate.co.uk>

- [3] R. Saidur, M. Islam, N. Rahim, K. Solangi, A review on global wind energy policy, *Renewable and Sustainable Energy Reviews* 14 (7) (2010) 1744–1762.
- [4] Renewable Energy Policy Network for the 21st Century (REN21), *Renewables 2016 global status report*.
- [5] Global wind energy council (GWEC), *Global wind statistic*.  
URL <http://www.gwec.net>
- [6] Ü. Cali, *Grid and Market Integration of Large-Scale Wind Farms Using Advanced Wind Power Forecasting: Technical and Energy Economic Aspects*, Vol. 17, kassel university press GmbH, 2011.
- [7] M. Esteban, D. Leary, Current developments and future prospects of offshore wind and ocean energy, *Applied Energy* 90 (1) (2012) 128–136.
- [8] X. Sun, D. Huang, G. Wu, The current state of offshore wind energy technology development, *Energy* 41 (1) (2012) 298–312.
- [9] G. Quinonez-Varela, G. Ault, O. Anaya-Lara, J. McDonald, Electrical collector system options for large offshore wind farms, *IET Renewable Power Generation* 1 (2) (2007) 107–114.
- [10] S. Rodrigues, C. Restrepo, E. Kontos, R. T. Pinto, P. Bauer, Trends of offshore wind projects, *Renewable and Sustainable Energy Reviews* 49 (Supplement C) (2015) 1114 – 1135.
- [11] J. S. González, R. Lacal-Aránategui, A review of regulatory framework for wind energy in european union countries: current state and expected developments, *Renewable and Sustainable Energy Reviews* 56 (2016) 588–602.
- [12] P. Sorknæs, A. N. Andersen, J. Tang, S. Strøm, Market integration of wind power in electricity system balancing, *Energy Strategy Reviews* 1 (3) (2013) 174–180.
- [13] Aaron Smith, Tyler Stehly, and Walter Musial, 2014–2015 offshore wind technologies market report, National Renewable Energy Laboratory (2015) 1–114.  
URL <https://www.osti.gov/scitech/>
- [14] J. S. González, R. L. Aránategui, The regulatory framework for wind energy in eu member states. part 1 of the study on the social and economic value of wind energy– windvalueEU (2015).  
URL <https://ec.europa.eu/jrc/en/publications-list>
- [15] M. Dicorato, G. Forte, M. Pisani, M. Trovato, Guidelines for assessment of investment cost for offshore wind generation, *Renewable energy* 36 (8) (2011) 2043–2051.
- [16] J.-Y. Kim, K.-Y. Oh, K.-S. Kang, J.-S. Lee, Site selection of offshore wind farms around the korean peninsula through economic evaluation, *Renewable Energy* 54 (2013) 189–195.
- [17] E. Konstantinidis, D. Kompolias, P. Botsaris, Viability analysis of an offshore wind farm in north aegean sea, greece, *Journal of Renewable and Sustainable Energy* 6 (2) (2014) 023116.
- [18] F. Hvelplund, B. Möller, K. Sperling, Local ownership, smart energy systems and better wind power economy, *Energy Strategy Reviews* 1 (3) (2013) 164–170.
- [19] H. Lund, F. Hvelplund, P. A. Østergaard, B. Möller, B. V. Mathiesen, P. Karnøe, A. N. Andersen, P. E. Morthorst, K. Karlsson, M. Münster, et al., System and market integration of wind power in denmark, *Energy Strategy Reviews* 1 (3) (2013) 143–156.
- [20] A. G. Gonzalez-Rodriguez, Review of offshore wind farm cost components, *Energy for Sustainable Development* 37 (2017) 10–19.
- [21] M. Satir, F. Murphy, K. McDonnell, Feasibility study of an offshore wind farm in the aegean sea, turkey, *Renewable and Sustainable Energy Reviews* accepted (2017) –.
- [22] Per Nielsen, *Windpro 3.0*, EMD international a/s (2015).  
URL <https://www.emd.dk/windpro>
- [23] Natural Resources Canada (NRC), *RETscreen* (2017).  
URL <http://www.nrcan.gc.ca/energy/software-tools/7465>
- [24] M. Kenisarin, V. M. Karlı, M. Çağlar, Wind power engineering in the world and perspectives of its development in turkey, *Renewable and Sustainable Energy Reviews* 10 (4) (2006) 341–369.
- [25] C. İlkiliç, H. Aydın, Wind power potential and usage in the coastal regions of turkey, *Renewable and Sustainable Energy Reviews* 44 (2015) 78–86.
- [26] E. Erdogdu, On the wind energy in turkey, *Renewable and Sustainable Energy Reviews* 13 (6) (2009) 1361–1371.



- [27] B. Yaniktepe, M. Savrun, T. Koroglu, Current status of wind energy and wind energy policy in turkey, *Energy Conversion and Management* 72 (2013) 103–110.
- [28] M. Melikoglu, Vision 2023: assessing the feasibility of electricity and biogas production from municipal solid waste in turkey, *Renewable and Sustainable Energy Reviews* 19 (2013) 52–63.
- [29] M. Y., The place of wind energy in meeting the electrical energy needs of turkey, *The Chamber of Electrical Engineers (EMO) Publications* 3 (2007) 45–50.
- [30] V. Yerci, Türkiye denizlerindeki rüzgâr enerjisi potansiyeli ve deniz üstü rüzgâr santralleri kurulabilecek bölgelerin belirlenmesi, M.Sc. thesis, Mevlana Üniversitesi (2015).
- [31] M. Argin, V. Yerci, The assessment of offshore wind power potential of turkey, in: *Electrical and Electronics Engineering (ELECO)*, 2015 9th International Conference on, IEEE, 2015, pp. 966–970.
- [32] M. Argin, V. Yerci, Offshore wind power potential of the black sea region in turkey, *International Journal of Green Energy* 14.
- [33] J. Murphy, K. Lynch, L. Serri, D. Airdoldi, M. Lopes, Site selection analysis for offshore combined resource projects in europe, *Results of the FP7 ORECCA Project Work Package 2* (2011) 1–117.
- [34] L. Cradden, C. Kalogeri, I. M. Barrios, G. Galanis, D. Ingram, G. Kallos, Multi-criteria site selection for offshore renewable energy platforms, *Renewable energy* 87 (2016) 791–806.
- [35] K. Rados, G. Larsen, R. Barthelmie, W. Schlez, B. Lange, G. Schepers, T. Hegberg, M. Magnisson, Comparison of wake models with data for offshore windfarms, *Wind Engineering* 25 (5) (2001) 271–280.
- [36] Siemens AG 2015, Wind turbine swt-3.6-107 technical specifications (2015).  
URL [www.siemens.com/wind](http://www.siemens.com/wind)
- [37] Turkish Wind Energy Association (TWEA), Turkish wind power plant atlas.  
URL <http://www.tureb.com.tr>
- [38] S. B. Bhandari, Discounted payback period-some extensions, *Journal of Business and Behavioral Sciences* 21 (1) (2009) 28–38.
- [39] F. Sharkey, Economic challenges and optimisation of ocean energy electrical systems.
- [40] J. Rebled Lluch, Power transmission systems for offshore wind farms: Technical-economic analysis, B.S. thesis, Universitat Politècnica de Catalunya (2015).
- [41] C. Moné, M. Hand, M. Bolinger, J. Rand, D. Heimiller, J. Ho, 2015 cost of wind energy review.
- [42] P. Boquist, Offshore wind power investment model using a reference class forecasting approach to estimate the required cost contingency budget, M.S. thesis (2015).
- [43] M. A. Ünlü, Offshore wind power economics: analysis on the economic utilization of turkey’s offshore wind power potential under the current support mechanisms, M.S. thesis (2012).
- [44] J. Green, A. Bowen, L. J. Fingersh, Y.-H. Wan, et al., Electrical collection and transmission systems for offshore wind power, in: *Offshore technology conference*, Offshore Technology Conference, 2007.
- [45] ABB, Xlpe submarine cable systems (2017).  
URL [www.abb.com/cables](http://www.abb.com/cables)
- [46] W. Kempton, S. McClellan, D. Ozkan, Massachusetts offshore wind future cost study, University of Delaware.
- [47] Ninja, Renewables (2017).  
URL <https://www.renewables.ninja/>
- [48] I. Staffell, S. Pfenninger, Using bias-corrected reanalysis to simulate current and future wind power output, *Energy* 114 (2016) 1224–1239.
- [49] A. Smith, T. Stehly, W. Musial, 2014-2015 offshore wind technologies market report, Tech. rep., National Renewable Energy Lab.(NREL), Golden, CO (United States) (2015).