

(12) INTERNATIONAL APPLICATION PUBLISHED UNDER THE PATENT COOPERATION TREATY (PCT)

(19) World Intellectual Property
Organization
International Bureau(10) International Publication Number
WO 2016/185435 A1(43) International Publication Date
24 November 2016 (24.11.2016)

(51) International Patent Classification:

G01B 17/00 (2006.01) G01N 29/11 (2006.01)
G01N 29/44 (2006.01) G01N 29/34 (2006.01)
G01N 29/06 (2006.01) G01N 29/46 (2006.01)
G01M 3/24 (2006.01) G01N 22/02 (2006.01)
F16L 1/12 (2006.01) G01B 17/04 (2006.01)

(21) International Application Number:

PCT/IB20 16/052969

(22) International Filing Date:

20 May 2016 (20.05.2016)

(25) Filing Language:

Italian

(26) Publication Language:

English

(30) Priority Data:

102015000016565 21 May 2015 (21.05.2015) IT

(71) Applicant: SAIPEM S.P.A. [IT/IT]; Via Martiri di Cefalonia, 67, 20097 San Donate Milanese, MILANO (IT).

(72) Inventors: CALZAVARA, Adriano; c/o Saipem S.p.A., Via Martiri di Cefalonia, 67, 20097 San Donate Milanese, MILANO (IT). BERNASCONI, Giancarlo; c/o Saipem S.p.A., Via Martiri di Cefalonia, 67, 20097 San Donate Milanese, MILANO (IT). SIGNORI, Massimo; c/o

Saipem S.p.A., Via Martiri di Cefalonia, 67, 20097 San Donate Milanese, MILANO (IT).

(74) Agents: MOZZI, Matteo et al; c/o Jacobacci & Partners S.p.A., Via Senate, 8, 20121 Milano (IT).

(81) Designated States (unless otherwise indicated, for every kind of national protection available): AE, AG, AL, AM, AO, AT, AU, AZ, BA, BB, BG, BH, BN, BR, BW, BY, BZ, CA, CH, CL, CN, CO, CR, CU, CZ, DE, DK, DM, DO, DZ, EC, EE, EG, ES, FI, GB, GD, GE, GH, GM, GT, HN, HR, HU, ID, IL, IN, IR, IS, JP, KE, KG, KN, KP, KR, KZ, LA, LC, LK, LR, LS, LU, LY, MA, MD, ME, MG, MK, MN, MW, MX, MY, MZ, NA, NG, NI, NO, NZ, OM, PA, PE, PG, PH, PL, PT, QA, RO, RS, RU, RW, SA, SC, SD, SE, SG, SK, SL, SM, ST, SV, SY, TH, TJ, TM, TN, TR, TT, TZ, UA, UG, US, UZ, VC, VN, ZA, ZM, ZW.

(84) Designated States (unless otherwise indicated, for every kind of regional protection available): ARIPO (BW, GH, GM, KE, LR, LS, MW, MZ, NA, RW, SD, SL, ST, SZ, TZ, UG, ZM, ZW), Eurasian (AM, AZ, BY, KG, KZ, RU, TJ, TM), European (AL, AT, BE, BG, CH, CY, CZ, DE, DK, EE, ES, FI, FR, GB, GR, HR, HU, IE, IS, IT, LT, LU, LV, MC, MK, MT, NL, NO, PL, PT, RO, RS, SE, SI, SK, SM, TR), OAPI (BF, BJ, CF, CG, CI, CM, GA, GN, GQ, GW, KM, ML, MR, NE, SN, TD, TG).

[Continued on nextpage]

(54) Title: SYSTEM AND METHOD FOR REAL TIME REMOTE MEASUREMENT OF GEOMETRIC PARAMETERS OF A PIPELINE IN THE LAUNCH STEP, THROUGH SOUND WAVES

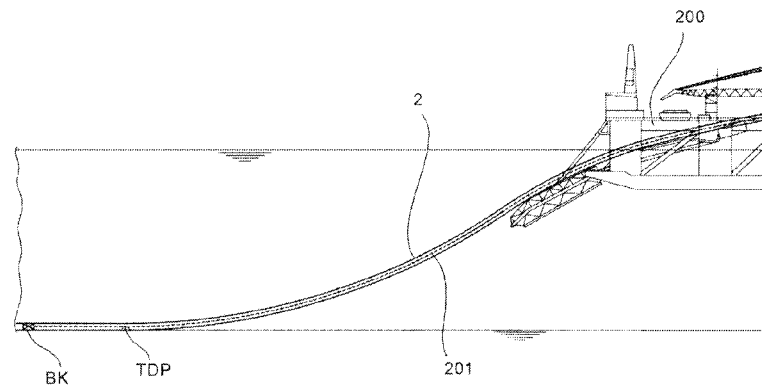

FIG. 7

(57) Abstract: A system 100 for real time remote measurement, through sound waves, of geometric parameters of a pipeline 2 in the launch step is described. System 100 comprises an acoustic transceiver unit which can be positioned in pipeline 2, and a control unit. The acoustic transceiver unit 1 comprises an acoustic transmission unit 4 configured to emit an input acoustic signal sal into pipeline 2, based on an electric pilot signal sp; and further comprises an acoustic receiving unit 5, distinct from the acoustic transmission unit 4, configured to detect the input acoustic signal sal and to generate a first electric measurement signal sel, dependent on the input acoustic signal sal. The acoustic receiving unit 5 is further configured to receive an input return signal sa2, generated in pipeline 2 and dependent on the input acoustic signal sal and on the geometric parameters of pipeline 2, and to generate a second electric measurement signal se2 based on the return acoustic signal sa2. The control unit 3 is configured to generate the electric pilot signal sp and is operatively connected to the acoustic transceiver unit 1 to provide the electric pilot signal sp and to receive the first electric measurement signal sel and the second electric measurement signal se2. Furthermore, the control unit 3 is configured to measure the geometric parameters of pipeline 2 based on the first and second

[Continued on nextpage]



WO 2016/185435 A1

Published:

— with international search report (Art. 21(3))

DESCRIPTION

"System and method for real time remote measurement of geometric parameters of a pipeline in the launch step, through sound waves"

5 Field of application .

The present invention relates to a system and corresponding method for real time remote measurement of geometric parameters of a pipeline in the launch step, through sound waves.

10 State of the art.

During the launch step of pipelines for underwater conduits, by means of a pipeline-laying ship 200 (as diagrammatically shown in figure 7), the integrity of the pipeline 2 itself must be ensured from the handling on
15 the ship 200 to the final arrangement on the seabed.

However, various factors, including the welding operations on the ship 200, the passage on the supporting transit facilities of the pipelines aboard the ship 200, the curvature of the pipeline in the launch step, the
20 contact with the seabed, and so on, may cause local deformations of the pipelines 2 which may develop into greater damage, e.g. local dents or buckles, with possible critical consequences during and after the steps of installation.

25 For this reason, monitoring the geometric

parameters of a pipeline, by means of real time measurement, in the launch step is a very important aspect for the timely diagnostics of any anomalies.

The detection of such anomalies may activate the
5 implementation of corrective actions during the laying campaign itself with apparent advantages.

The non-reliable detection or failure to detect such anomalies may cause costly incidents during laying and when the line is in service, such as for example the
10 interruption of the supply of hydrocarbons or environmental decay.

Currently, a measurement instrument which is normally used to identify the presence of defects, such as dents or buckles, springs or excessive deformations,
15 related to the launching of a pipeline, is the so-called "buckle detector" BK, i.e. a mechanical instrument consisting of a circular gauge fitted on a carriage connected to the ship by means of a metal cable 201, and of a load cell adapted to monitor the tension of the
20 metal cable.

The carriage is kept in an appropriate span position so as to monitor the critical zones subject to the most strain, which thus show the most anomalies or geometry deformations.

25 The carriage moves relative to the pipeline in the

launch thereof and provides an alarm on the presence of deformations which may obstruct its forward travel and which are detected as the increased tension of the metal cable .

5 In such known solutions, the choice of the gauge size is indicated in standards, as a function of the inner diameter of the pipeline to be monitored, or in project specifications. Some typical production defects of the pipeline, such as ovalization, misalignment or
10 inner diameter variability, are factors which influence the monitoring reliability.

The use of a mechanical instrument, such as the "buckle detector" BK, is invasive and implies operative difficulties, risks and other drawbacks.

15 Firstly, such a mechanical instrument is very cumbersome, given the presence of the metal cable, the carriage and the load cell; furthermore, it must be always present in the pipeline and constantly monitored and managed during the laying operations.

20 Furthermore, the metal cable for the continuous connection between ship 200 and the "buckle detector" BK may reach a length of even hundreds of meters with the possibility of breakage due to the sliding inside the pipeline .

25 This influences the accuracy and reliability of the

measurement .

Additionally, the launching, recovery and maintenance operations of the "buckle detector" BK (the latter operation being needed because of the mechanical wear caused by continuous operation) are highly time-consuming .

Furthermore, from the operative point of view, the "buckle detector" BK can detect a single anomaly in a single point with a low level of accuracy and repeatability of the measurement, with the risks of missed or false alarms.

Again, the use of a "buckle detector" BK may be risky because the following may occur during the operation of laying a pipeline: breakage of the metal cable; jamming of the "buckle detector" BK during the movement; one or more damages to the inner lining of the pipeline mainly caused by the passage of the metal cable. In light of these drawbacks, technical developments tends to prefer, where possible, the switch from an invasive approach (with the use of "buckle detector" BK) to a non-invasive approach.

In this regards, some systems are known on experimental level which detect anomalies in a pipeline by means of the non-intrusive transmission of radio-frequency (RF) electromagnetic waves in the pipeline

itself (which operates as an electromagnetic waveguide) .

The radio-frequency (RF) electromagnetic waves are transmitted by a launch source in an open end of the pipeline and the radio-frequency (RF) electromagnetic waves reflected by the inner walls of the pipelines are acquired by a processing unit. By implementing processing algorithms of the signal the processing unit estimates the presence of anomalies in the pipeline based on a comparison of the energy of the emitted signal and of the energy of the reflected signal.

Such a solution is used to obtain measurements with acceptable levels of accuracy, but has a limited applicability range in terms of distance (because of the attenuation to which the electromagnetic waves are subjected), i.e. has limits in the length of the pipeline stretch which can be monitored. These limits may be very penalizing in some situations.

Furthermore, in some situations, in which the electromagnetic waves are in the microwave field, reflected waves may be received deriving from a plurality of very small-sized defects which are negligible for monitoring purposes but which generate a non-negligible cumulative result on the overall received reflected wave and may even cause a sort of "self-jamming" of the electromagnetic receiver.

The need is thus felt to provide non-invasive monitoring and measuring systems capable of ensuring suitable precision in the detection of defects and anomalies (avoiding the aforesaid self-jamming phenomena at the same time) on long distances (thus capable of monitoring long stretches of pipeline), and also capable of determining the position, shape and geometric parameters of each detected defect with great accuracy.

In particular, the need is felt to identify defects and anomalies related to some relevant zones of the pipeline, e.g. with reference to i) contact zone of the pipeline with the seabed (TDP - Touch Down Point); ii) zones of the pipeline span with the most curvature; iii) exit zone of the pipeline from the ship, i.e. from the dedicated supporting structure ("stinger"); iv) contact zones between pipeline and supports (e.g. roller beds) arranged on the ship or along the "stinger". The relevant zones may be at distances in the order of hundreds of meters to kilometers from the head of the pipeline.

Furthermore, in the technical reference field, the need is strongly felt to detect even macroscopic obstacles possibly present in the pipeline and/or progressive wavefronts which may run in the pipelines, so as to intervene more promptly than currently possible.

Summary of the invention.

It the object of the present invention to provide a system for real time remote measurement, through sound waves, i.e. by means of pressure waves which propagate in the fluid inside the pipeline, of geometric parameters of a pipeline in the launch step which allows to overcome at least partially the drawbacks described above with reference to the prior art, and to meet to the aforesaid needs particularly felt in the considered technical field.

It is a further object of the present invention a method for real time remote measurement, through sound waves, i.e. by means of pressure waves which propagate in the fluid inside the pipeline, of geometric parameters of a pipeline in the launch step, which method can be carried out by the aforesaid system.

Such an object is achieved by a system according to claim 1.

Further embodiments of such a system are defined in claims 2-22 .

A method according to the invention is defined in claim 23.

Further embodiments of such a method are defined in claims 24-32 .

Brief description of the drawings .

Further features and advantages of the system and

corresponding method for real time remote measurement, through sound waves, i.e. by means of pressure waves which propagate in the fluid inside the pipeline, of geometric parameters of a pipeline in the launch step according to the present invention will become apparent from the following description of preferred embodiments shown by way of non-limiting example with reference to the accompanying drawings, in which:

- figure 1 shows a functional block chart of the system according to an embodiment of the invention;

- figure 2 shows a functional block chart of a further embodiment of the system;

- figure 3 shows some possible acoustic propagation modes in a cylindrical pipe;

- figures 4A and 4B show a mechanical/structural conformation of a further embodiment of the system;

- figure 5 diagrammatically shows a portion of the system and a cross section of a pipeline the defects of which can be detected by the system itself;

- figure 6 shows a simplified diagram of a propagation and acoustic reflection model used in an embodiment of the method according to the invention;

- figure 7 diagrammatically shows a measuring technique belonging to the prior art, in the context of the launching of a pipeline on the seabed, by using a

ship; and

- figures 8a-8e diagrammatically show examples of arrangement of acoustic transmission elements and acoustic receiving elements provided in various
5 embodiments of the system.

Detailed description.

A system for real time remote measurement, through sound waves, of geometric parameters of a pipeline in the launch step hereinafter also simply referred to as
10 system, indicated as a whole by reference numeral 100, will be described below with reference to figure 1. Further detailed examples of the aforesaid geometric parameters will be disclosed below.

For the purposes of the present description, it is
15 worth noting that acoustic waves mean pressure waves which propagate in the fluid inside the pipeline, e.g. at a minimum frequency of a few Hz and a maximum frequency depending, for example, on the diameter of the pipeline. For example, for a diameter of 4" (inches), i.e. about 10
20 cm, the maximum propagation frequency of an acoustic wave in the fluid of the pipeline is about 1,500 Hz, while for a diameter of 60" (inches), i.e. about 150 cm, the maximum propagation frequency of an acoustic wave in the fluid of the pipeline is about 100 Hz.

25 The system 100 comprises an acoustic transceiver

unit 1, which can be positioned in a pipeline 2 (a portion of which is diagrammatically shown in figure 1), and a control unit 3.

The acoustic transceiver unit 1 comprises an acoustic transmission unit 4, configured to emit an input acoustic signal $sa1$ into the pipeline 2, based on an electric pilot signal sp .

The acoustic transceiver unit 1 further comprises an acoustic receiving unit 5, distinct from the acoustic transmission unit 4, configured to detect the input acoustic signal $sa1$ and to generate a first electric measurement signal $se1$, dependent on the input acoustic signal $sa1$.

The acoustic receiving unit 5 is further configured to receive an input return signal $sa2$, generated in the pipeline 2 and dependent on the input acoustic signal $sa1$ and on the geometric parameters of the pipeline, and to generate a second electric measurement signal $se2$ based on the return acoustic signal $sa2$.

The control unit 3 is configured to generate the electric pilot signal sp and is operatively connected to the acoustic transceiver unit 1 to provide the electric pilot signal sp and to receive the first electric measurement signal $se1$ and the second electric measurement signal $se2$.

Furthermore, the control unit 3 is configured to measure the geometric parameters of the pipeline 2 based on the first electric measurement signal $se1$ and on the second electric measurement signal $se2$.

5 It is worth noting that in the above-described system 100, the acoustic transmission unit 4 and the acoustic receiving unit 5 can work independently.

Furthermore, the control unit 3 can measure the geometric parameters of the pipeline 2 taking into
10 account the acoustic return signal $sa2$ (e.g. generated by reflections/echoes in the pipeline 2) as well as the actual acoustic input signal $sa1$, which is accurately measured by the acoustic receiving unit 5 itself instead of being approximately estimated.

15 In other words, the acoustic receiving unit 5 measures both the acoustic input signal $sa1$ emitted by the acoustic transmission unit 4 and the acoustic return signal $sa2$.

The Applicant has indeed found that, by means of
20 experiments, the exact knowledge of the acoustic input signal $sa1$ is a very important factor during the step of processing the echoes in order to obtain an accurate quantitative estimate of the defects.

It is worth noting that, in various examples of
25 application, the geometric parameters of the pipeline 2

which may be measured by the system 100 include the section and/or the shape of the pipeline 2 (along the longitudinal development of the length of the pipeline 2 itself), e.g. the diameter of the pipeline which can be
5 from about 4" (about 10 cm) to about 60" (about 150 cm), and/or defects or anomalies (e.g. dents or buckles) present along the pipeline 2, in any position.

In the case of defects or anomalies, the geometric parameters which can be measured with the present system
10 100 comprise the position, shape, and size of each detected defect or anomaly.

With regard to the positioning of the acoustic transceiver unit 1, it is worth noting that it may be inserted in any point inside the pipeline 2, but
15 preferably in the first stretch of the pipeline 2, still arranged on the pipeline-laying ship 200, and more preferably in head of the pipeline 2 itself, where the head of the pipeline 2 means the termination of the pipeline 2 on the side of the pipeline-laying ship 200.

20 According to a particular embodiment of the system, shown in figure 2, the acoustic transmission unit 4 comprises at least two acoustic transmission elements 6, 6' configured to emit an input acoustic signal sal comprising at least one mode of acoustic propagation.

25 In such a case, the control unit 3 is configured to

generate an electric pilot signal sp comprising one or more electric pilot signals sp' , sp'' adapted to control each of the at least two acoustic transmission elements 6 , $6'$.

5 On the other hand, the acoustic receiving unit 5 comprises at least two acoustic receiving elements 7 , $7'$ configured to receive an acoustic signal $sa2$ comprising the aforesaid at least one mode of acoustic propagation.

According to an optional embodiment, the aforesaid 10 at least two acoustic transmission elements 6 , $6'$ are configured to emit an input acoustic signal $sa1$ comprising the fundamental mode of acoustic propagation and at least one further mode of acoustic propagation.

Furthermore, in such a case, the aforesaid at least 15 two acoustic receiving elements 7 , $7'$ are configured to receive an acoustic signal $sa2$ comprising at least the fundamental mode of acoustic propagation and at least one further mode of acoustic propagation.

Advantageously, in such an option of 20 implementation, a multiplicity of propagation modes may be generated, registered and identified (e.g. such as those shown in figure 3), each of which may be sensitive to various geometric parameters of the possible defects of the pipeline 2 (e.g. dents), thus allowing a greater 25 robustness and a greater accuracy in identifying and

reconstructing the type of anomaly.

For example, the fundamental acoustic mode (0,0) is symmetric to the axis of the pipeline 2 and is sensitive to changes of section, while mode (1,0) is anti-symmetric and thus capable of locating the position of a possible dent along the circumference of the pipeline 2; and so on.

According to a further optional embodiment, the aforesaid at least two acoustic transmission elements 6, 6' are configured to emit a first transmitted acoustic signal sal' and a second transmitted acoustic signal sal", which acoustically combine to form the input acoustic signal sal.

According to a variant embodiment, the two acoustic transmission elements 6, 6' can be controlled independently from each other, so that the first transmitted acoustic signal sal' and the second transmitted acoustic signal sal" are different from each other, to determine a plurality of possible input acoustic signals.

Thereby, there are various degrees of freedom for generating acoustic input signals shaped and/or modulated in the most diverse manners, and adapted to the intended purposes .

For example, beats can be generated which modulate

the input acoustic signal *sal*.

According to an embodiment of the system, shown in figure 2, each of the aforesaid acoustic transmission units 4 or acoustic transmission element 6, 6' and each
5 of the aforesaid acoustic receiving units 5 or acoustic receiving element 7, 7' comprises an electro-acoustic transducer, of type known *per se*.

Furthermore, the control unit 3 comprises an acquisition unit 8 of the first electric measurement
10 signal *se1* and of the second electric measurement signal *se2*, an electric pilot signal generating unit 9 and a processor 10.

The processor 10 is configured to carry out processing aimed at measuring the geometric parameters of
15 the pipeline 2, based on the first electric measurement signal *se1* and second electric measurement signal *se2*, and also to control the electric pilot signal generating unit 9.

The electric pilot signal generating unit 9, in a
20 typical embodiment, comprises an electric signal generator 11, a modulator (implicitly included in the block 11) and an amplifier 12.

As will also be disclosed below, the electric signal generator 11 may be configured to generate a wide
25 plurality of different signals and waveforms: e.g.

waveforms with "chirp" (in particular, non-linear chirp), or Ricker waves, or Ormsby waves, or Klauder waves, and so on.

According to an embodiment of system 100, the acoustic transmission unit 4 comprises a matrix of loudspeakers, arranged in predetermined positions as acoustic transmission elements 6, 6'; the acoustic receiving unit 5 comprises a matrix of microphones, arranged in predetermined positions as acoustic receiving elements 7, 7'.

According to different variants of embodiment, the number, geometric arrangement, position, reciprocal distances of the acoustic transmission elements and of the acoustic receiving elements may be the most different, according to the specific desired acoustic reception and transmission requirements and the requirements concerning the propagation modes to be reproduced (e.g. of those shown in figure 3).

Different examples of arrangement of acoustic transmission elements 6, 6' and of acoustic reception elements 7, 7', provided in different options of embodiment of the system, are shown in figures 8a - 8e.

As previously shown, the degrees of freedom offered by the presence of multiple acoustic emitters and receivers advantageously determine the possibility to

manage acoustic signals comprising a multiplicity of propagation modes according to that desired in order to optimize the measurement accuracy and efficacy of the geometric parametric of the pipeline.

5 Furthermore, the matrix of transmission elements allows a more effective management of the emitted powers and also the possibility of generating complex waveforms by emitting different signals from each transmission element (e.g. to generate beats) .

10 According to an embodiment of the system (which may also be provided autonomously with respect to the other embodiments disclosed in this description) , the control unit 3 is configured to perform the following operations: defining an analysis waveform and generating the electric
15 pilot signal s_p so that the input acoustic signal s_{a1} is modulated by means of the defined analysis waveform; further defining an expected propagation model; thus, estimating an ideal acoustic return signal, based on the analysis waveform and the expected propagation model;
20 then, carrying out a comparison between the estimated ideal acoustic return signal, within a time window, and the detected return acoustic signal s_{a2} based on the second electric measurement signal s_{e2} , within a corresponding time window; finally, obtaining the
25 geometric parameters of the pipeline 2 , based on the

aforesaid comparison.

The geometric parameters thus obtained are representative of an actually detected shape of the pipeline 2 and of anomalies and/or defects found.

5 It is worth noting that the control unit 3 is configured to estimate the ideal return signal and to detect the return acoustic signal sa2 based on the aforesaid first and second electric measurement signals sel, se2 .

10 According to an option of implementation, the control unit 3 is configured to define the analysis waveform based on a desired range of distances within which to detect defects, and/or based on a type of defects to be detected and/or based on an expected
15 defect .

According to another optional embodiment, the system further comprises means for detecting background noise; in such a case, the control unit 3 is configured to define the analysis waveform by taking the detected
20 background noise into account. Such a background noise may be an ambient noise present in the pipeline or an external ambient noise (e.g. coming from external machinery) which enters into the pipeline 2. In this regard, several variants are provided. For the internal
25 ambient noise, the system 100 itself may be activated in

advance with respect to the emission of the input acoustic signal, so as to initially register the background noise; assuming that this noise is stationary, the sound emission is shaped in frequency to ensure an appropriate noise signal ratio on the entire concerned band .

For the external ambient noise, the means for detecting background noise are sound sensor of the known type, arranged outside the pipeline 2 (possibly near sources of ambient noise) and configured to register such external noise during the entire operative step. During the step of data processing, adaptive noise reduction techniques are used, which minimize the correlation between the external measurement and that inside the pipeline.

According to different variants of embodiment, the control unit 3 is configured to generate the analysis waveform as a sinusoidal waveform modulated in frequency by means of "chirp" and/or modulated in amplitude; or, in other variants, as a Ricker type wave or a Klauder type wave or an Ormsby type wave.

According to an optional embodiment, the control unit is configured to define the expected propagation model based on geometric parameters of a geometric model of the pipeline in the absence of laying anomalies.

According to a further optional embodiment, the control unit 3 is configured to define the expected propagation model also taking into account thermodynamic parameters of the fluid (e.g. air) contained in the pipeline, as will be disclosed below.

According to an embodiment, the control unit 3 is configured to carry out the aforesaid comparison by means of a cross-correlation between the estimated ideal acoustic return signal, within a time window, and the detected acoustic return signal sa2, within a corresponding time window.

According to an optional embodiment, the control unit 3, in order to obtain the geometric parameters of the pipeline 2, is configured to carry out the following operations: determining a spatial reflection function of the pipeline, representative of reductions in diameter of the pipeline as a function of the distance based on the comparison between the estimated ideal acoustic return signal and the detected acoustic return signal sa2; then, identifying presence and spatial position of defects (e.g. 20 in figure 5) based on the aforesaid spatial reflection function; then, defining an estimated real geometric model of the pipeline, having an estimated defect at the identified defect position; furthermore, calculating an expected acoustic return signal, based on

the estimated real geometric model of the pipeline; then, modifying geometric parameters of the estimated real geometric model of the pipeline 2, based on a cross-correlation between the expected acoustic return signal and the detected acoustic return signal sa2, within a time window corresponding to the position around the identified defect; finally, repeating the aforesaid modification process until there is a convergence of the aforesaid geometric parameters, to obtain a real geometric model of the pipeline 2 representative of the detected shape of the pipeline 2 and of the anomalies found.

Further details on the processing functionality of the control unit 3 will be described hereinafter by disclosing a method according to the invention.

According to an embodiment, the system 100 further comprises means for detecting the ambient pressure configured to supply the control unit 3 with information representative of the detected ambient pressure.

According to a further optional embodiment, the control unit 3 is configured to store temperature information and/or temperature profiles present or expected along the pipeline 2.

The control unit 3 is configured to define the expected propagation model and/or estimating the ideal

return acoustic signal taking into account said ambient pressure and/or temperature information.

In such cases, the information relates to the pressure and temperature variations along the pipeline 2
5 are included in the propagation and the return acoustic signal estimate simulations. Since such pressure and temperature variations influence the wave propagation speed and the wave attenuation, the possibility of taking them into account allows to achieve a greater accuracy in
10 the defect positioning and quantification, respectively.

According to an optional embodiment, the control unit 3 is configured to store a plurality of measurements of geometric parameters and to estimate a spatial-temporal evolution of one or more sections of the
15 pipeline 2 based on said plurality of measurements.

According to another option of implementation, system 100 further comprises means for estimating the shape of the pipeline 2 in the launch step configured to measure the cross sections of portions of the pipeline in
20 the launch step while still aboard the launching means and to provide information representative of the shape of the pipeline 2, in the launch step and before laying, to the control unit 3, based on the progressively measured cross sections.

25 In such a case, the control unit 3 is configured to

measure the geometric parameters of the pipeline also taking into account the aforesaid information representative of the shape of the pipeline 2 in the launch step and still aboard a pipeline-laying naval vessel 200.

According to an embodiment of the system (shown in figures 4A and 4B), the acoustic transceiver unit 1 can be mechanically integrated in a single module 30 to be applied to the inner clamp adapted to manage coupling and welding of portions of the pipeline 2 in the launch step and generally known as ILUC (Internal Line Up Clamp); the control unit 3 can be integrated in the same module 30.

In a variant embodiment, the control unit 3 can be arranged remotely with respect to the acoustic transceiver unit 1 and the system further comprises electronic communication means between the acoustic transceiver unit 1 and the control unit 3.

Hereinafter, a method will be described for real time remote measurement, through sound waves, i.e. pressure waves which propagate in the fluid in the pipeline (as previously defined), of geometric parameters of a pipeline in the launch step. Such a method can be executed by means of a system 100 such as the previously described one.

The method comprises the steps of emitting, into

the pipeline 2, an input acoustic signal sal , based on an electric pilot signal sp , by means of an acoustic transmission unit 4; thus, detecting the aforesaid input acoustic signal sal , by means of an acoustic receiving unit 5, distinct from the acoustic transmission unit 4, and generating a first electric measurement signal sel , dependent on the input acoustic signal sal . The method further provides for receiving, by means of the acoustic receiving unit 5, a return acoustic signal $sa2$, generated in the pipeline 2 and dependent on the input acoustic signal sal and on the geometric parameters of the pipeline 2, and generating a second electric measurement signal $se2$ based on the return acoustic signal $sa2$; finally, the step of measuring the geometric parameters of the pipeline 2, by means of a control unit 3, based on the first and second electric measurement signals (sel , $se2$, respectively) .

According to an embodiment of the method, the step of emitting an input acoustic signal sal comprises emitting a first transmitted acoustic signal sal' , by means of a first element 6 of the acoustic transmission unit 4, and a second transmitted acoustic signal sal'' , by means of a second element 6' of the acoustic transmission unit 5, respectively, in which the first transmitted acoustic signal sal' and the second transmitted acoustic

signal sal" combine to form the input acoustic signal sal .

According to an optional embodiment, the method comprises the further steps of defining an analysis waveform and generating the electric pilot signal sp so
5 that the input acoustic signal sal is modulated by means of the defined analysis waveform; further defining an expected propagation model; then, estimating an ideal acoustic return signal, based on the analysis waveform
10 and the expected propagation model; thus, carrying out a comparison between the estimated ideal acoustic return signal, within a time window, and the return acoustic signal sa2 detected based on the second electric measurement signal se2, within a corresponding time
15 window, finally, obtaining the geometric parameters of the pipeline 2, based on the aforesaid comparison, in which the obtained geometric parameters are representative of a shape actually detected of the pipeline 2 and of anomalies and/or defects 20 found.

20 According to an optional embodiment, the step of defining the analysis waveform comprises defining the analysis waveform based on a desired range of distances within which to detect defects, and/or based on a type of defects to be detected and/or based on an expected
25 defect.

According to an embodiment, the method further comprises the steps of detecting background noise and defining the analysis waveform taking into account the detected background noise.

5 According to a variant of embodiment, the step of generating the analysis waveform comprises generating a sinusoidal waveform modulated in frequency by means of "chirp" and/or modulated in amplitude and/or as a Ricker type wave or a Klauder type wave or an Ormsby type wave.

10 According to another embodiment of the method, the step of defining the expected propagation model comprises defining the expected propagation model based on geometric parameters of a geometric model of the pipeline without laying anomalies and/or based on thermodynamic
15 parameters of the fluid contained in the pipeline.

According to a further embodiment of the method, the step of carrying out a comparison comprises carrying out a cross-correlation between the estimated ideal acoustic return signal, within a time window, and the
20 detected acoustic return signal sa_2 , within a corresponding time window.

According to an optional embodiment of the method, the step of obtaining the geometric parameters of the pipeline 2 comprises: determining, based on the
25 comparison between the estimated ideal acoustic return

signal and the detected acoustic return signal sa_2 , a spatial reflection function of the pipeline 2, representative of reductions in diameter of the pipeline as a function of the distance; thus, identifying presence and spatial position of defects 20 based on the aforesaid spatial reflection function; moreover, defining an estimated real geometric model of the pipeline 2, having an estimated defect at the identified defect position; then, calculating an expected acoustic return signal, based on the estimated real geometric model of the pipeline; thus, modifying geometric parameters of the estimated real geometric model of the pipeline, based on a cross-correlation between the expected acoustic return signal and the detected acoustic return signal sa_2 , within a time window corresponding to the position around the identified defect; finally repeating the aforesaid modification process until there is a convergence of the geometric parameters, to obtain a real geometric model of the pipeline representative of the detected shape of the pipeline 2 and of the anomalies found.

According to the various options of embodiment, the method is adapted to measure parameters relative to any combination of the following anomalies: geometric defects; dents; variations in section diameter; variations in section shape; blockages and/or obstacles

present in the pipeline; significant discontinuities of the properties of the fluid contained in the pipeline; displacement of objects and/or defects in the pipeline between successive measurements; presence of water in the pipeline.

In an embodiment of the present invention, with reference again to the estimation and measurement algorithms of the geometric parameters of the pipeline, it is worth noting that a recognition technique of the acoustic signal reflected by a geometric anomaly of the pipeline (e.g. a dent 20) may be exploited. Advantageously, in this case, the input acoustic signal is provided so as to "interact" with the geometric anomaly of the pipe, so as to determine a reflected signal which contains, in its shape/amplitude as a whole as well as its energy, the information necessary and sufficient to reconstruct the concerned geometric parameters of the dent itself. In such a case, the availability of a matrix or array of elements 6, 6', in the acoustic transmission unit 5, connected to an arbitrary electric pilot signal generator 11, ensures a wide range of flexibility. In this regard, for example, the formulas known in literature (see for example: s. Del Giudice, G. Bernasconi "Acoustic response of a sinusoidally perturbed hard walled duct", Mathematical

Problems in Engineering Volume 2013, Article ID 267291) are used, which formulas, with a formalism similar to that used to describe the Bragg effect, represent the bond between the shape of a dent (broken down as sum of 5 sinusoidal dents along the pipe axis) and the amplitude and frequency content of the reflected acoustic signal. By combining such formulas with those which describe the attenuation of an acoustic signal propagating in a pipe (also known), it is possible to obtain the definition of 10 an optimal emitted waveform (the aforesaid "analysis waveform"), i.e. a waveform capable of reaching a given distance (so that the total attenuation remains over a given threshold, e.g. over the sensitivity of the receiver) and to obtain information on the reflection 15 caused by a possible dent, in a given case which can be defined *a priori* (e.g. in a family of dents defined by the user), on all spatial sinusoidal components, frequency by frequency.

Thereby, the relationship which binds the dent to 20 the reflected acoustic signal may be "inverted", to obtain the actual geometric parameters of the dent without ambiguity from the acoustic return signal (i.e. from the second electric measurement signal). For example, such an "inversion" may be performed by means of 25 a Bayesian inversion according to the so-called

"Tarantola's method". The inversion algorithm is stored and executed by the processor 10 of the control unit 3.

In such an embodiment, the method uses the observed parameter measurements to adapt the parameters of the physical model. Furthermore, the inversion algorithm uses a probabilistic flat wave acoustic propagation model characteristic for cylindrical pipes, with temperature calibration along the length of the pipeline to improve accuracy (taking into account the actual sound propagation speed). The "model space" represents the predictive physical model and is characterized by the parameters $\underline{m} = \{m_1, m_2, \dots, m_M\}$; the "data space" represents measurable variables and is characterized by parameters $\underline{d} = \{d_1, d_2, \dots, d_M\}$. Both the aforesaid parameter vectors are known with a margin of uncertainty.

The method may start processing from the model parameters and data, known *a priori* with a probability density $\mathbf{p}(\underline{d}, \underline{m}) = \mathbf{p}_D(\underline{d}) \mathbf{p}_M(\underline{m})$, which are used by a theoretical model $\theta(\underline{d}, \underline{m})$.

The data σ are obtained *a posteriori* as a function of the *a priori* data \mathbf{p} , of the model state Θ and of their homogenous distribution μ :

$$\sigma(\underline{d}, \underline{m}) = k \frac{\rho(\underline{d}, \underline{m}) \Theta(\underline{d}, \underline{m})}{\mu(\underline{d}, \underline{m})}$$

and the *a posteriori* probability density of the

model, integrated in the data space, may be written as:

$$\sigma_M(m) = \int \frac{\rho(d,m)\Theta(d,m)}{\mu(d,m)} dd$$

the formula being applied to the acoustic model to allow a particularly effective convergence, generally limited to a few iteration cycles. The Applicant has found that this formula allows to obtain a method which can be executed by a relatively simple hardware system and on the other hand is compatible with the required accuracy requirements of the calculation and with the production processes of the launching operations.

The steps of the method listed above are indicated below in greater detail. In the embodiment shown here, the anomaly detection algorithm firstly provides for choosing the range of distances to be analyzed; then, defining the analysis waveform (source) and further registering the ambient noise used for a possible shaping of the input acoustic signal to be emitted. The method then provides for emitting an analysis waveform and simultaneously registering it, and thus registering the echoes (acoustic return signal) from the pipeline. So, the next method step provides for identifying the defects, which is achieved by means of the following further steps.

The propagation of the analysis waveform is

theoretically determined according to the theoretical model (the pipeline/ fluid system features being known, such as diameter, thermodynamic properties of the air and so on) at increasing distances along the entire range of analysis distances. Then, the theoretically propagated waveform is compared, by means of cross-correlation, with the acoustic return signal (i.e. according to the second electric measurement signal) registered in the time window corresponding to the same distance. The result of such a cross-correlation is a reflection index along the pipeline having an amplitude proportional to a possible section reduction; a threshold criteria thus identifies the presence and the position of the defects.

According to the above, a time portion of the acoustic return signal is extracted containing the wave reflected by the defect, i.e. the observed datum, in a surround of the identified defect positions. So an iterative inversion procedure is activated which compares the observed data with the calculated data in a pipeline model with a hypothesized defect: the residue between data and estimate of the estimated data variations with respect to the defect parameters (Jacobian) guides the updating of the model and iteration of the procedure until convergence. The estimated model at the last iteration step displays the geometric parameters of the

real defect.

It is worth noting that the method shown above, in all the described embodiments, allows to identify/locate and quantify the geometric defects in a given family of
5 defects defined *a priori* and also to identify further anomalies with high accuracy.

Indeed, in an embodiment, the method can also identify and locate obstructions and/or obstacles in the pipeline, such as objects fallen during the launch, total
10 obstructions or partial obstructions of the pipeline.

According to another example of application, the method can recognize significant discontinuities of the properties of the contained liquid (e.g. the air/water contact surface) .

15 According to a yet further embodiment, the method provides for the repeated execution of the localization procedure of defects and obstructions, in known successive times, and the consequent calculation of possible "movements" of the defects between successive
20 measurements, comprising the speed of such movements. Thereby, the method allows to trace the movement of obstacles in the pipeline and the detection of a water source, and of the corresponding movements, possibly present within the pipeline.

25 Hereinafter, with reference to figure 6, some

details are shown, all known *per se*, of the propagation channel modeling, on which the step of theoretically defining the acoustic wave propagation is based.

The pressure wave propagation $P(x,t)$ in the pipeline generated by the input acoustic signal may be represented by the formula:

$$P(x,t) = P(0,t) * e^{-\alpha x} * e^{j2\pi \cdot f(t-x/c_f)}$$

where x is the distance from the acoustic transmission unit; α is the attenuation coefficient, which can be also expressed as:

$$\left(\frac{1}{\text{PipeRadius}}\right) * \sqrt{(\pi * f * \mu) / (\rho * \text{SoundSpeed}^2)} * ((1 + (\gamma - 1) / \sqrt{\text{Pr}}))$$

c_f is the phase speed, which can also be expressed as

$$\text{SoundSpeed} / \left(1 + \alpha * \frac{\text{SoundSpeed}}{2 * \pi * f}\right)$$

μ is the viscosity; ρ is the density; Pr is the Prandtl number, i.e. $\mu * C_p / k$, C_p is the specific heat; k is the thermal conductivity; γ is the ratio of the specific heats; "SoundSpeed" is the speed of sound; "PipeRadius" is the radius of the pipeline.

Considering that a geometric anomaly produces the partial reflection of the incident signal, the amplitude of the reflected part may be expressed as:

$$R = P_r / P_i = (S1 - S2) / (S1 + S2)$$

while the amplitude of the transmitted acoustic wave which continues to propagate in beyond the anomaly may be

expressed as:

$$T_{P_i} = 2 * S_1 / (S_1 + S_2)$$

where S_1 is the area of the tube section and S_2 is the area of the section at the geometric anomaly.

5 In figure 6, the input acoustic signal sa_1 is indicated as a pressure wave P_1 ; the return acoustic signal sa_2 is indicated as a pressure wave P_2 ; the transmitted or reflected pressure waves, in the various sections of the pipeline, are indicated by references P_1 ,
 10 P_3 , P_4 , P_5 , P_6 .

Now considering a discretization of the cylindrical pipeline sections 1, $i-1$, i , ..., n , and considering an equivalent source which generates a monochromatic wave at section i , each successive section generates a
 15 transmitted wave {downward "d", rightwards) and a reflected wave {upward "u", leftwards), each of which is characterized by different reflection coefficients $R_i^d, T_i^d, R_i^u, T_i^u$. The reflection coefficients may be calculated according to the sum of the single waves determined on
 20 the single section.

As can be observed, the objects of the invention are achieved by the system and method described above by virtue of the features shown above.

Indeed, the above-described system allows to use
 25 non-invasive techniques, which solves at the root all the

previously mentioned drawbacks with reference to the invasive techniques (e.g. based on "buckle detectors") .

Furthermore, the choice of using acoustic waves instead of electromagnetic waves (exploiting the fact that a pipeline can be a waveguide also for acoustic waves) allows to carry out monitoring measurements on wide distances, adapted to cover the pipeline stretches during laying in most of the possible real situations.

At the same time, the structural and functional features of the system allow to use the acoustic waves (input and return acoustic signals) so as to obtain considerable accuracy which is appropriate to the type of use .

In particular, the presence of an acoustic transmission unit and of an acoustic receiving unit which are mutually distinct allows to monitor both the acoustic return signal and the actual input acoustic signal accurately, which in turn allows to obtain measurements of accuracy adapted to needs.

It is worth noting that the signal processing carried out by the above-described present system advantageously allows to meet the further needs to detect the presence and also the type and position of the defects with great accuracy. Indeed, as described above, the system can execute algorithms based on a processing

of the entire acoustic return signal (and in particular of all its spectrum components) and not only a measurement of the energy of such a signal.

Finally, by virtue of its structural and functional features, the system can detect "geometric" defects of the pipeline and, as described above, also the presence of possible obstacles in the pipeline, the movement of such obstacles and the presence of possible water in the pipeline .

Similar advantages can be identified with reference to the above-described methods employing the above system.

Furthermore, the field of application of the present invention further comprises the "reel" launching technique in addition to the "S-laying" and "J-laying" techniques .

Those skilled in art may make changes and adaptations to the embodiments of the above-described system for real time remote measurement, through sound waves, of geometric parameters of a pipeline in the launch step, and they can also replace elements with others which are functionally equivalent in order to meet contingent needs without departing from the scope of protection of the following claims. All the features described above as belonging to a possible embodiment may

be implemented irrespective of the other embodiments described .

CLAIMS

1. System (100) for real time remote measurement, through sound waves, of geometric parameters of a pipeline (2) in the launch step, comprising an acoustic transceiver unit (1), able to be positioned in the pipeline (2), and a control unit (3), wherein the acoustic transceiver unit (1) comprises:

- an acoustic transmission unit (4) configured to emit an input acoustic signal (sal) into the pipeline (2), based on an electric pilot signal (sp);
- an acoustic receiving unit (5), distinct from the acoustic transmission unit (4), configured to detect the input acoustic signal (sal) and to generate a first electric measurement signal (sel), dependent on the input acoustic signal (sal), the acoustic receiving unit (4) also being configured to receive an input return signal (sa2), generated in the pipeline (2) and dependent on the input acoustic signal (sal) and on the geometric parameters of the pipeline (2), and to generate a second electric measurement signal (se2) based on the return acoustic signal (sa2);

and wherein the control unit (3) is configured to generate the electric pilot signal (sp) and is operatively connected to the acoustic transceiver unit (1) to provide the electric pilot signal (sp) and to

receive the first electric measurement signal (se1) and the second electric measurement signal (se2), the control unit (3) also being configured to measure the geometric parameters of the pipeline (2) based on the
5 first electric measurement signal (se1) and the second electric measurement signal (se2) .

2. System (100) according to claim 1, wherein:

- the acoustic transmission unit (4) comprises at least two acoustic transmission elements (6, 6')
10 configured to emit an input acoustic signal (sal) comprising at least one mode of acoustic propagation;

- the acoustic receiving unit (5) comprises at least two acoustic receiving elements (7, 7') configured to receive an acoustic signal comprising said at least one
15 mode of acoustic propagation;

- the control unit (3) is configured to generate an electric pilot signal (sp) comprising one or more electric pilot signals (sp', sp'') suitable for controlling each of the at least two acoustic
20 transmission elements (6, 6') .

3. System (100) according to claim 2, wherein:

- said at least two acoustic transmission elements (6, 6') are configured to emit an input acoustic signal (sal) comprising the fundamental mode of acoustic
25 propagation and at least one further mode of acoustic

propagation;

- said at least two acoustic receiving elements (7, 7') are configured to receive an acoustic signal comprising at least said fundamental mode of acoustic propagation and at least one further mode of acoustic propagation .

4. System (100) according to claim 2 or 3, wherein said at least two acoustic transmission elements (6, 6') are configured to respectively emit a first transmitted acoustic signal (sal') and a second transmitted acoustic signal (sal"), said first (sal') and second acoustic signal acoustically combining to form the input acoustic signal (sal) .

5. System (100) according to claim 2 or 3, wherein two acoustic transmission elements (6, 6') can be controlled independently from each other, so that the first transmitted acoustic signal (sal') and the second transmitted acoustic signal (sal") are different from each other, to determine a plurality of possible input acoustic signals (sal) .

6. System (100) according to any one of the previous claims, wherein:

- each of said acoustic transmission units (4) or acoustic transmission element (6, 6') and each of said acoustic receiving units (5) or acoustic receiving

element (7, 7') comprises an electro-acoustic transducer,
and wherein the control unit (3) comprises:

- an acquisition unit (8) of the first electric measurement signal (se1) and of the second electric measurement signal (se2);
- an electric pilot signal generating unit (9);
- a processor (10), configured to carry out processing aimed at measuring the geometric parameters of the pipeline (2), based on said first (se1) and second electric measurement signal (se1), and also to control the electric pilot signal generating unit (9) .

7. System (100) according to any one of claims 2-6, wherein :

- said at least two acoustic transmission elements (6, 6') comprise a matrix of loudspeakers (6, 6'), arranged in predetermined positions;
- said at least two acoustic receiving elements (7, 7') comprise a matrix of microphones (7, 7') arranged in predetermined positions.

8. System (100) according to any one of the previous claims, wherein the control unit (3) is configured to:

- define an analysis waveform and generate the electric pilot signal (sp) so that the input acoustic signal (sa1) is modulated through the analysis waveform defined;

- define an expected propagation model;
- estimate an ideal acoustic return signal, based on the analysis waveform and the expected propagation model;
- carry out a comparison between the estimated ideal
5 acoustic return signal, within a time window, and the acoustic return signal (sa2) detected based on the second electric measurement signal (se2), within a corresponding time window;
- obtain the geometric parameters of the pipeline
10 (2), based on said comparison, the geometric parameters obtained being representative of a shape actually detected of the pipeline (2) and of anomalies and/or defects (20) found.

9. System (100) according to claim 8, wherein the
15 control unit (3) is configured to define the analysis waveform based on a desired range of distances within which to detect defects, and/or based on a type of defects to be detected and/or based on an expected defect .

20 10. System (100) according to claim 8 or 9, also comprising means for detecting background noise, and wherein the control unit (3) is configured to define the analysis waveform taking into account the background noise detected.

25 11. System (100) according to any one of claims 8 to

10, wherein the control unit (3) is configured to generate the analysis waveform as a sinusoidal waveform modulated in frequency through "chirp" and/or modulated in amplitude and/or as a Ricker type wave or a Klauder type wave or an Ormsby type wave.

12. System (100) according to claim 8, wherein the control unit (3) is configured to define the expected propagation model based on geometric parameters of a geometric model of the pipeline in the absence of laying anomalies.

13. System (100) according to claim 12, wherein the control unit (3) is configured to define the expected propagation model also taking into account thermodynamic parameters of the fluid contained in the pipeline (2) .

14. System (100) according to claim 8, wherein the control unit (3) is configured to estimate the ideal acoustic return signal and to detect the acoustic return signal (sa2) based on said first (se1) and second electric measurement signal (se2) .

15. System (100) according to any one of claims 8 to 14, wherein the control unit (3) is configured to carry out said comparison through a cross-correlation between the estimated ideal acoustic return signal, within a time window, and the detected acoustic return signal (sa2), within a corresponding time window.

16. System (100) according to any one of claims 7-15, wherein the control unit (3), in order to obtain the geometric parameters of the pipeline (2), is configured to carry out the following operations:

- 5 - determining, based on the comparison between the estimated ideal acoustic return signal and the detected acoustic return signal (sa2), a spatial reflection function of the pipeline, representative of reductions in diameter of the pipeline (2) as a function of the distance;
- 10 - identifying presence and spatial position of defects (20) based on said spatial reflection function;
- defining an estimated real geometric model of the pipeline, having an estimated defect at the defect position identified;
- 15 - calculating an expected acoustic return signal, based on the estimated real geometric model of the pipeline ;
- modifying geometric parameters of the estimated real geometric model of the pipeline, based on a cross-correlation between the expected acoustic return signal and the detected acoustic return signal (sa2), within a time window corresponding to the position around the defect identified;
- 20 - repeating said modification process until there is

a convergence of the geometric parameters, to obtain a real geometric model of the pipeline representative of the detected shape of the pipeline and of the anomalies found .

5 **17.** System (100) according to any one of the previous claims, also comprising means for detecting the ambient pressure configured to supply the control unit (3) with information representative of the ambient pressure detected .

10 **18.** System (100) according to any one of the previous claims, wherein the control unit (3) is configured to store temperature information and/or temperature profiles present or expected along the pipeline (2) .

19. System (100) according to claim 8 and claims 17
15 and/or 18, wherein the control unit (3) is configured to define the expected propagation model taking into account said ambient pressure and/or temperature information.

20. System (100) according to any one of the previous claims, wherein the control unit (3) is configured to
20 store a plurality of measurements of geometric parameters and estimate, based on said plurality of measurements, a spatial-temporal evolution of one or more sections of the pipeline (2) .

21. System (100) according to any one of the previous
25 claims, also comprising means for estimating the shape of

the pipeline in the launch step and before laying, configured to measure the cross sections of portions of pipeline in the launch step and to provide the control unit (3) with information representative of the shape of the pipeline in the launch step and before laying, based on the cross sections progressively measured, and wherein the control unit (3) is configured to measure the geometric parameters of the pipeline (2) also taking into account said information representative of the shape of the pipeline in the launch step and still aboard a pipeline-laying naval vessel 200.

22. System (100) according to any one of the previous claims, wherein:

- the acoustic transceiver unit (1) can be mechanically integrated in an inner clamp (30) of a laying apparatus adapted to manage coupling and welding of portions of pipe in the launch step;

- the control unit (3) can be arranged remotely with respect to the acoustic transceiver unit (1), the system (100) also comprising communication means between the acoustic transceiver unit (1) and the control unit (3).

23. Method for real time remote measurement, through sound waves, of geometric parameters of a pipeline (2) in the launch step, comprising the steps of:

- emitting into the pipeline (2), by means of an acoustic transmission unit (4), an input acoustic signal (sal), based on an electric pilot signal (sp);
- detecting said input acoustic signal (sal), by means of an acoustic receiving unit (5), distinct from the acoustic transmission unit (4), and generating a first electric measurement signal (sel), dependent on the input acoustic signal (sal);
- receiving, by means of the acoustic receiving unit (5), a return acoustic signal (sa2), generated in the pipeline and dependent on the input acoustic signal (sal) and on the geometric parameters of the pipeline (2), and generating a second electric measurement signal (se2) based on the return acoustic signal (sa2);
- measuring the geometric parameters of the pipeline (2), by means of a control unit (3), based on the first (sel) and the second electric measurement signal (se2) .

24. Method according to claim 23, wherein the step of emitting an input acoustic signal (sal) comprises respectively emitting a first transmitted acoustic signal (sal'), by means of a first element (6) of the acoustic transmission unit (4), and a second transmitted acoustic signal (sal''), by means of a second element (6') of the acoustic transmission unit (4), wherein the first transmitted acoustic signal (sal') and the second

transmitted acoustic signal (sal") combine to form the input acoustic signal (sal) .

25. Method according to any one of claims 23-24, comprising the further steps of:

- 5 - defining a analysis waveform and generating the electric pilot signal (sp) so that the input acoustic signal (sal) is modulated through the analysis waveform defined;
- defining an expected propagation model;
- 10 - estimating an ideal acoustic return signal, based on the analysis waveform and the expected propagation model ;
- carrying out a comparison between the estimated ideal acoustic return signal, within a time window, and
15 the return acoustic signal (sa2) detected based on the second electric measurement signal (se2), within a corresponding time window,
- obtaining the geometric parameters of the pipeline (2), based on said comparison, the geometric parameters
20 obtained being representative of a shape actually detected of the pipeline and of anomalies and/or defects found .

26. Method according to claim 25, wherein the step of defining the analysis waveform comprises defining the
25 analysis waveform based on a desired range of distances

within which to detect defects, and/or based on a type of defects to be detected and/or based on an expected defect .

27. Method according to claim 25 or 26 also comprising
5 the steps of:

- detecting background noise;
- defining the analysis waveform taking into account the detected background noise.

28. Method according to any one of claims 25 to 27,
10 wherein the step of generating the analysis waveform comprises generating a sinusoidal waveform modulated in frequency through "chirp" and/or modulated in amplitude and/or as a Ricker type wave or a Klauder type wave or an Ormsby type wave.

15 29. Method according to claim 25, wherein the step of defining the expected propagation model based on geometric parameters of a geometric model of the pipeline without laying anomalies and/or on thermodynamic parameters of the fluid contained in the pipeline (2) .

20 30. Method according to one of claims 25 to 29, wherein the step of carrying out a comparison comprises carrying out a cross-correlation between the estimated ideal acoustic return signal, within a time window, and the detected acoustic return signal (sa2), within a
25 corresponding time window.

31. Method according to any one of claims 25-30, wherein the step of obtaining the geometric parameters of the pipeline comprises:
- determining, based on the comparison between the
5 estimated ideal acoustic return signal and the detected acoustic return signal (sa2), a spatial reflection function of the pipeline, representative of reductions in diameter of the pipeline (2) as a function of the distance ;
 - 10 - identifying presence and spatial position of defects (20) based on said spatial reflection function;
 - defining an estimated real geometric model of the pipeline, having an estimated defect at the defect position identified;
 - 15 - calculating an expected acoustic return signal, based on the estimated real geometric model of the pipeline ;
 - modifying geometric parameters of the estimated real geometric model of the pipeline, based on a cross-
20 correlation between the expected acoustic return signal and the detected acoustic return signal (sa2), within a time window corresponding to the position around the defect identified;
 - repeating said modification process until there is
25 a convergence of the geometric parameters, to obtain a

real geometric model of the pipeline representative of the detected shape of the pipeline and of the anomalies found .

32. Method according to any one of claims 25-31,
5 suitable for measuring parameters relative to any combination of the following anomalies:

- geometric defects; dents; variations in section diameter; variations in section shape; blockages and/or obstacles present in the pipeline; significant
10 discontinuities of the properties of the fluid contained in the pipeline; displacement of objects and/or defects in the pipeline between successive measurements; presence of water in the pipeline.

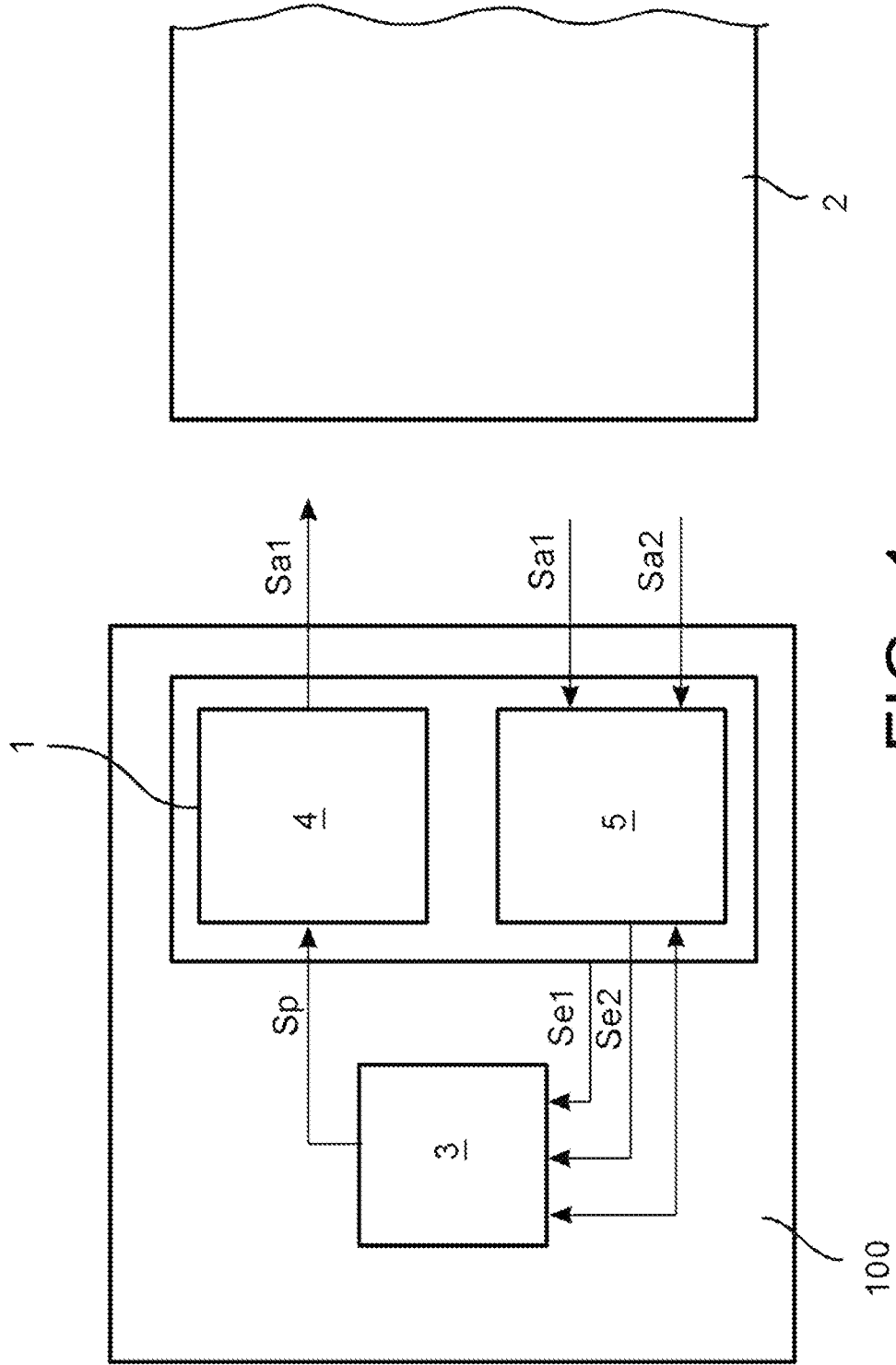

FIG. 1

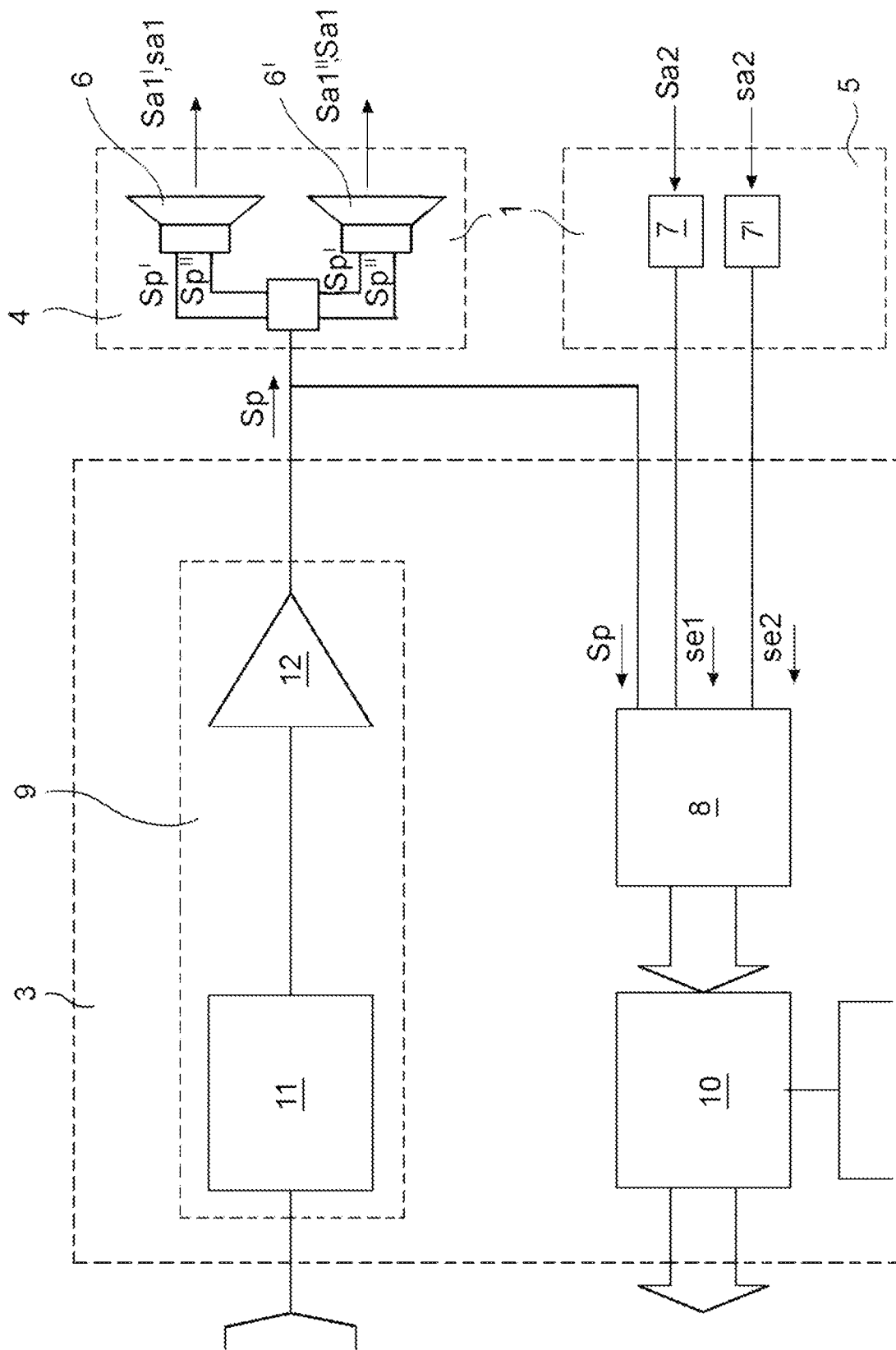

FIG. 2

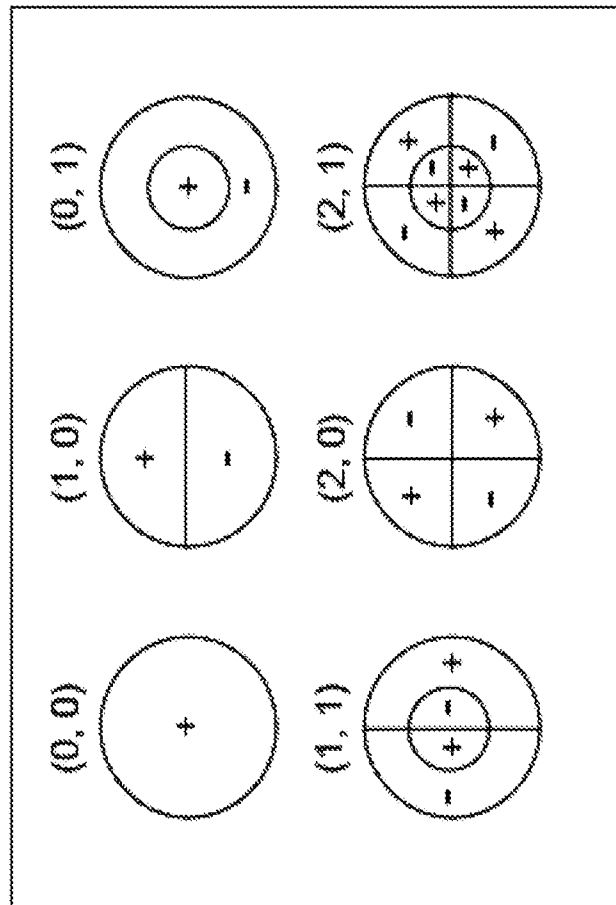

FIG. 3

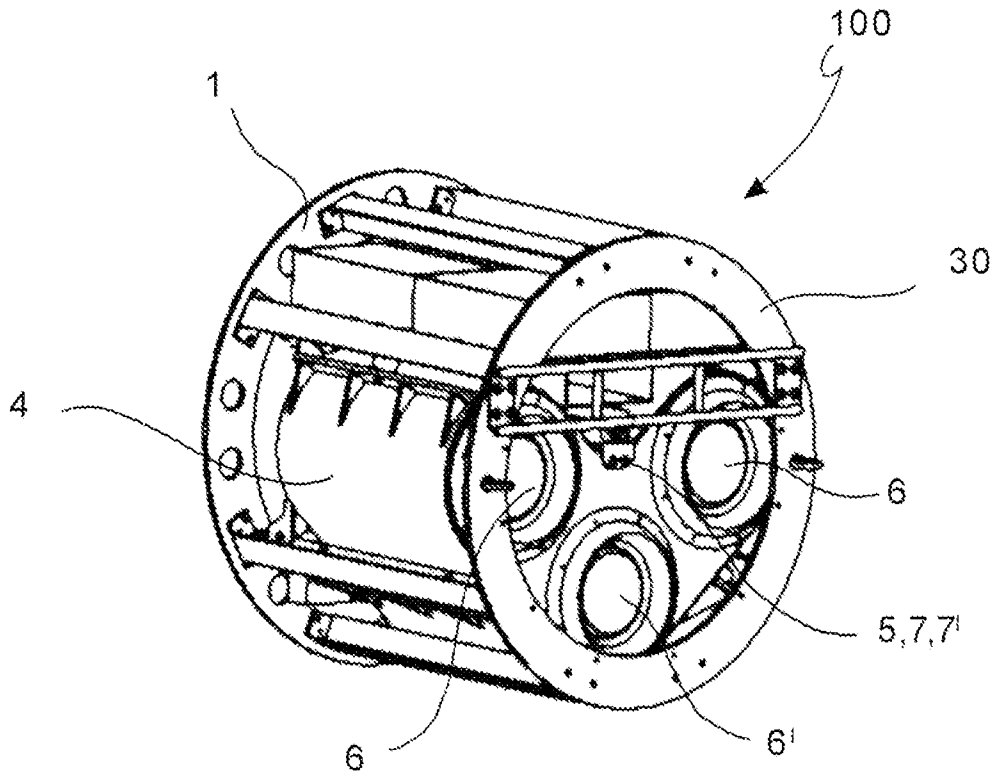

FIG. 4A

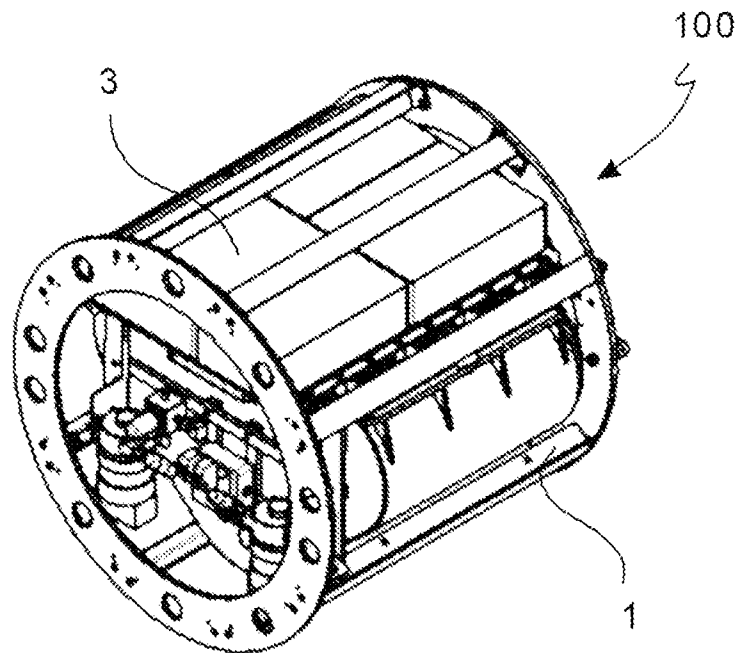

FIG. 4B

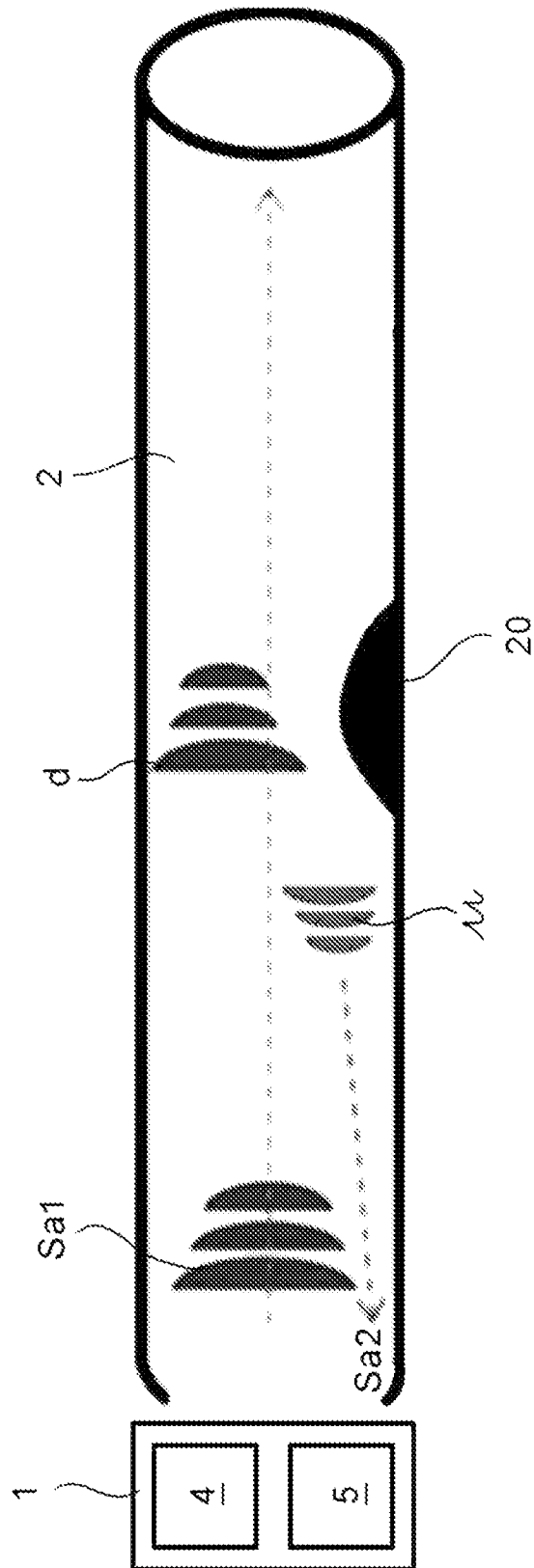

FIG. 5

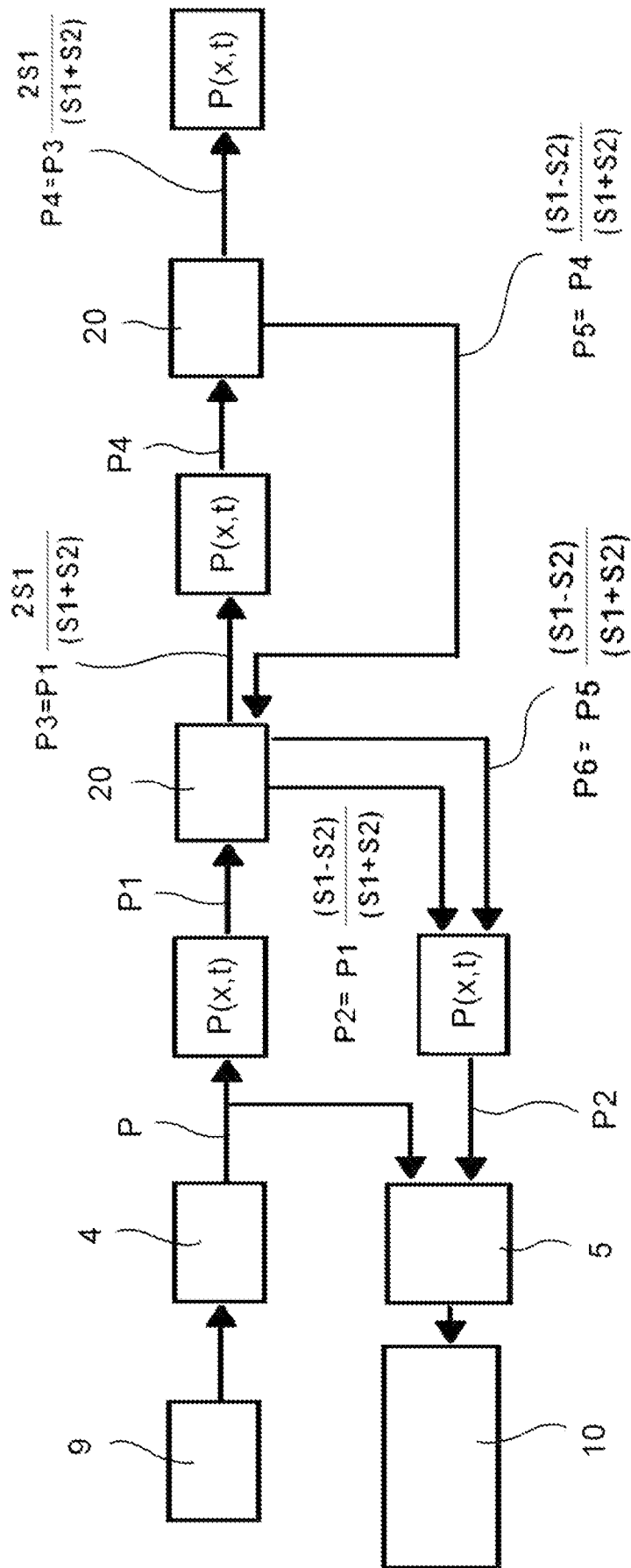

FIG. 6

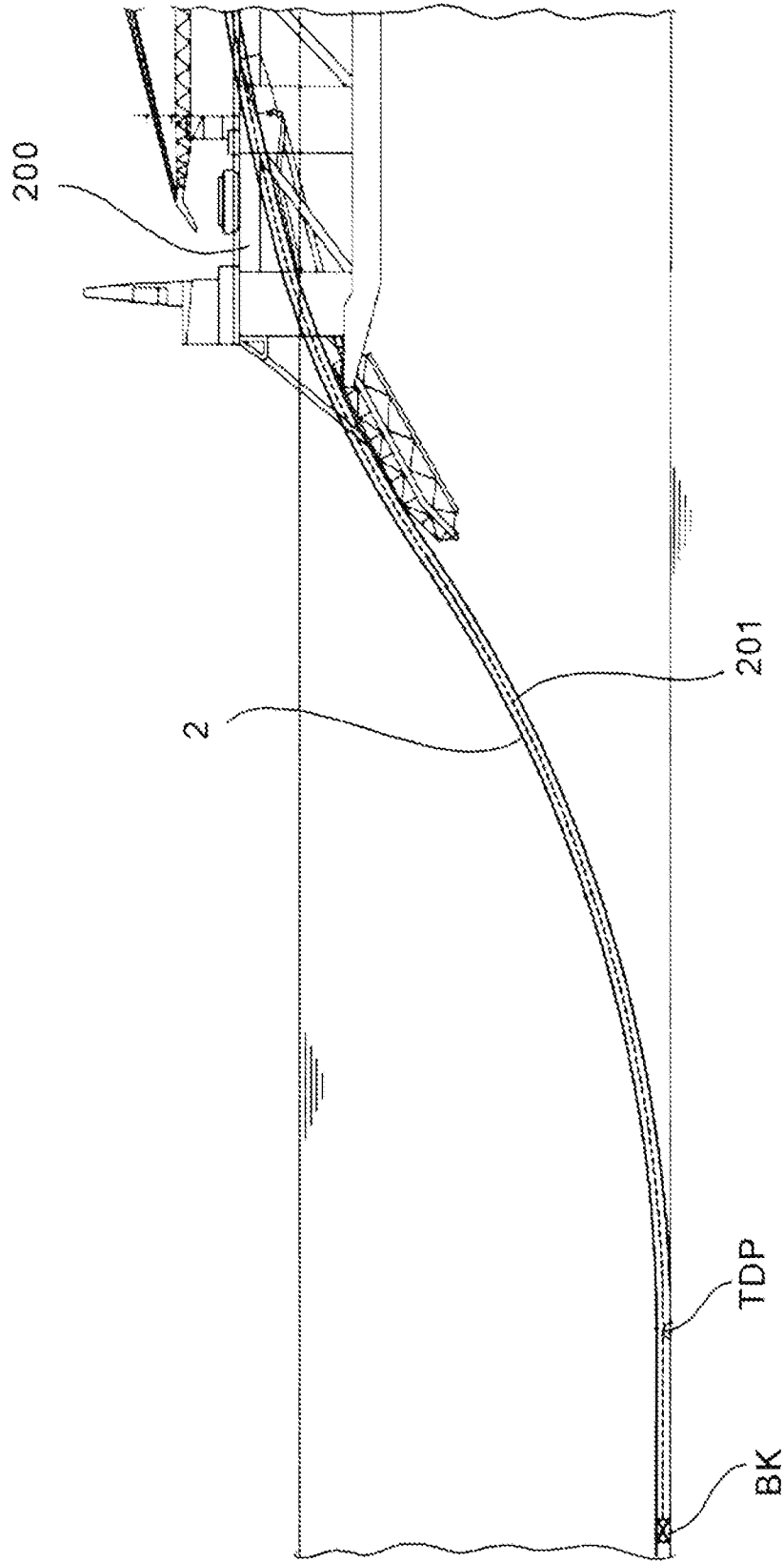

FIG. 7

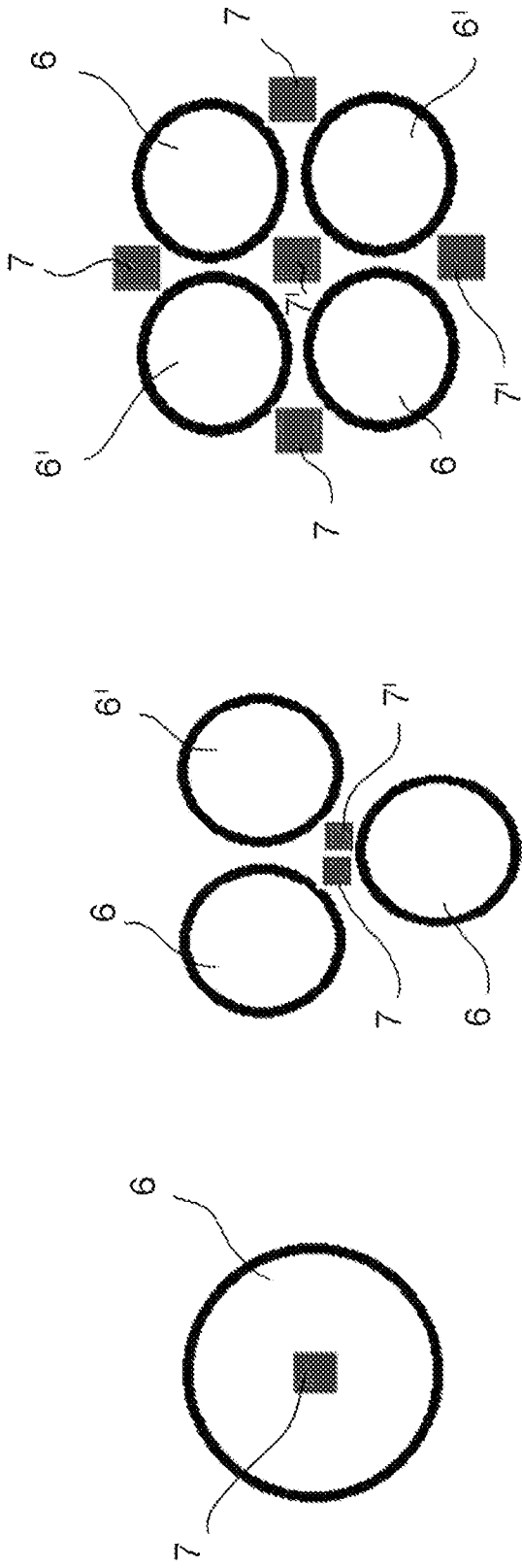

FIG. 8A

FIG. 8B

FIG. 8C

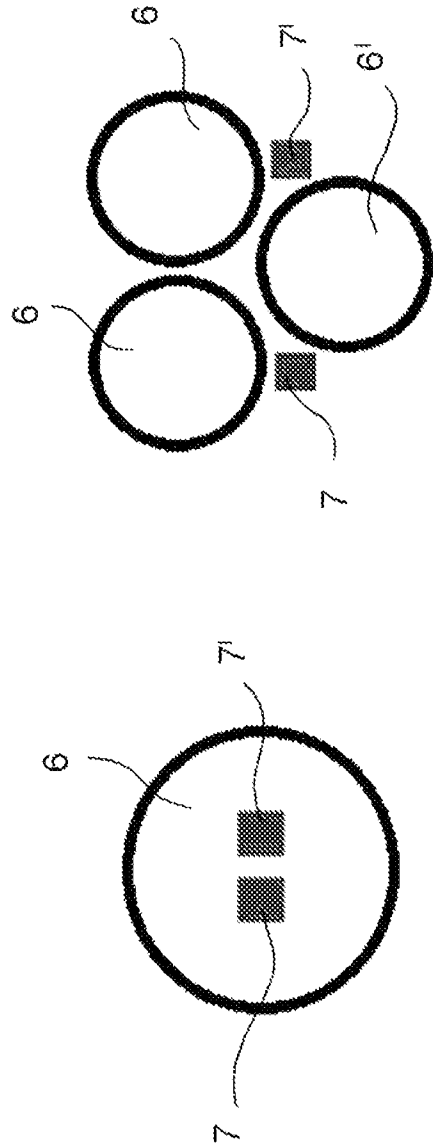

FIG. 8D

FIG. 8E

INTERNATIONAL SEARCH REPORT

International application No PCT/IB2016/052969

A. CLASSIFICATION OF SUBJECT MATTER		
INV. G01B17/00	G01N29/44	G01N29/06
G01N29/11	G01N29/34	G01N29/46
G01M3/24	F16L1/12	G01N22/02
G01B17/04		
ADD.		
According to International Patent Classification (IPC) or to both national classification and IPC		
B. FIELDS SEARCHED		
Minimum documentation searched (classification system followed by classification symbols)		
G01B G01N G01M F16L		
Documentation searched other than minimum documentation to the extent that such documents are included in the fields searched		
Electronic data base consulted during the international search (name of data base and, where practicable, search terms used)		
EPO-Internal		
C. DOCUMENTS CONSIDERED TO BE RELEVANT		
Category*	Citation of document, with indication, where appropriate, of the relevant passages	Relevant to claim No.
X	US 4 092 868 A (THOMPSON ROBERT B ET AL) 6 June 1978 (1978-06-06)	1
Y	the whole document -----	1-32
X	US 2013/286778 A1 (KISNER ROGER [US] ET AL) 31 October 2013 (2013-10-31)	1
Y	abstract; figures 10,11 paragraphs [0004] - [0008], [0037] - paragraphs [0042], [0083] - [0091] -----	1-32
X	US 5 995 447 A (MANDAL BATAKRISHNA [US] ET AL) 30 November 1999 (1999-11-30)	1
Y	abstract; figures 1,5 column 10 - column 18 -----	1-32
Y	US 6 751 560 B1 (TINGLEY ROBERT [US] ET AL) 15 June 2004 (2004-06-15)	1-32
	the whole document -----	
<input type="checkbox"/> Further documents are listed in the continuation of Box C. <input checked="" type="checkbox"/> See patent family annex.		
* Special categories of cited documents :		
"A" document defining the general state of the art which is not considered to be of particular relevance	"T" later document published after the international filing date or priority date and not in conflict with the application but cited to understand the principle or theory underlying the invention	
"E" earlier application or patent but published on or after the international filing date	"X" document of particular relevance; the claimed invention cannot be considered novel or cannot be considered to involve an inventive step when the document is taken alone	
"L" document which may throw doubts on priority claim(s) or which is cited to establish the publication date of another citation or other special reason (as specified)	"Y" document of particular relevance; the claimed invention cannot be considered to involve an inventive step when the document is combined with one or more other such documents, such combination being obvious to a person skilled in the art	
"O" document referring to an oral disclosure, use, exhibition or other means	"&" document member of the same patent family	
"P" document published prior to the international filing date but later than the priority date claimed		
Date of the actual completion of the international search	Date of mailing of the international search report	
16 August 2016	29/08/2016	
Name and mailing address of the ISA/ European Patent Office, P.B. 5818 Patentlaan 2 NL - 2280 HV Rijswijk Tel. (+31-70) 340-2040, Fax: (+31-70) 340-3016	Authorized officer Stanciu, C	

INTERNATIONAL SEARCH REPORT

Information on patent family members

International application No PCT/IB2016/052969

Patent document cited in search report	Publication date	Patent family member(s)	Publication date
US 4092868	A	06-06-1978	NONE

US 2013286778	A1	31--10--2013	NONE

us 5995447	A	30--11--1999	NONE

us 6751560	B1	15--06--2004	AU 7811101 A 13--02--2002
			BR 0112956 A 01--07--2003
			US 6751560 B1 1s--06--2004
			US 2002035437 A1 21--03--2002
			WO 0210709 A2 07--02--2002
