

**BIOCHEMICAL BASIS OF B CELL DYSFUNCTION
IN LYN KINASE DEFICIENT MICE**

Yuekang Xu

A thesis submitted in total fulfilment of the requirements of the degree of
Doctor of Philosophy

November, 2003

(Produced on acid-free paper)

The Walter and Eliza Hall Institute of Medical Research
Department of Medical Biology
University of Melbourne

ABSTRACT

B lymphocytes constitutes an important arm of the immune system, and their response to antigen is largely dependent upon signal transduction through the B cell receptor (BCR). Such a potent receptor, however, needs to be further balanced by positive and negative regulators to prevent harmful effects that may arise from inappropriate stimulation. Src family protein tyrosine kinase Lyn is involved in both positive and negative regulation, since the both gain-of-function Lyn and loss-of-function Lyn mutations caused autoimmunity in mice. The exact signalling pathway(s) regulated by Lyn in B cells, however, are still not clear. Work presented in this thesis attempts to elucidate the biochemical mechanisms that underline the double-edged nature of Lyn in BCR signalling.

CD19 is an important B cell co-receptor that helps to set the threshold for BCR signalling. Although CD19 expression level is same in $lyn^{-/-}$ and $lyn^{+/+}$ B cells, it was difficult to solubilize CD19 from $lyn^{-/-}$ mice by TX-100 detergent, compared with wild-type mice. Since lipid rafts are defined as a TX-100 insoluble domain of the plasma membrane, the possibility that CD19 was constitutively located in this signalling platform in Lyn-deficient B cells would explain the hyper-responsiveness of $lyn^{-/-}$ B cells. Therefore the membrane localization of CD19 in the absence of Lyn was examined carefully. Lipid rafts were found to possess all the necessary proposed properties as signalling platforms, such as containing the Src kinase family member Lyn and excluding the receptor phosphatase CD45. The BCR was rapidly translocated into the lipid raft domain after BCR cross-linking. In the resting state, however, CD19 was found to be outside lipid rafts in both wild type and $lyn^{-/-}$ B cells.

Given a normal membrane distribution of CD19 in the absence of Lyn, the biochemical consequences of BCR ligation in mouse B cells deficient in either Lyn or CD19 was examined for evidence of interaction or co-dependence between these molecules. In contrast to published results, the extent of CD19 phosphorylation following BCR ligation was unaffected by the absence of Lyn yet was dependent on other Src-family PTKs as it was inhibited fully by pp2, a Src-family specific inhibitor. Consistent with the normal phosphorylation of CD19 in $lyn^{-/-}$ B cells, the recruitment

of phosphoinositide-3 kinase to CD19 and the ability of CD19 to enhance both intracellular calcium flux and Erk1/2 activation after co-ligation with the BCR were intact in the absence of Lyn. Similarly, unique functions of Lyn were found to be independent of CD19. The increase in Lyn kinase activity following BCR ligation and the inhibition of BCR-mediated calcium flux by CD22 were both normal in CD19^{-/-} B cells. Collectively, these data argue that the unique functions of Lyn do not require CD19 and that the signal amplification mediated by CD19 is independent of Lyn. Therefore, the roles of Lyn and CD19 following BCR ligation are independent and opposing, one being primarily inhibitory and the other stimulatory.

The opposite phenotype of Lyn-deficient B cells to that of PI3K-deficient B cells prompted us to investigate the possibility that Lyn works through PI3K. We found that many aspects of the hyper-sensitive phenotype of Lyn-deficient primary B cells in response to BCR ligation, such as Erk MAP kinase activation, calcium elevation and hyper-proliferation were attenuated by removal of PI3K activity, suggesting an elevated PI3K pathway in the absence of Lyn. Furthermore, the specific activity of PI3K from lyn^{-/-} primary B cells was found to be higher both before and after BCR-stimulation, indicating the inhibition of PI3K activity by Lyn. In a search for the factors that cause the activation of PI3K in primary B cells, we found the BCR-induced phosphorylation of a PI3K associated protein was inhibited by pp2, a Src family PTK inhibitor, but elevated in Lyn-deficient primary B cells. Moreover, the Src family PTK activity was demonstrated to be required for the activation of PI3K in both wild type and Lyn-deficient primary B cells. On the basis of these data we propose a novel inhibitive mechanism of Lyn in BCR signalling acting on PI3K.

DECLARATION

This is to certify that

- (i) this thesis comprises my original work except as acknowledged below
- (ii) due acknowledgment has been made in the text to all other material used
- (iii) this thesis is less than 100, 000 words in length.

In accordance with the regulations of the University of Melbourne I assess my contribution of those chapters in this thesis as follows:

Chapter 3: 100%

Chapter 4: 90% with contributions from Amenda Light in Section 4.4.3 and Sara-Jane Beavitt in Section 4.3.5.

Chapter 5: 95% with contribution from Dr. Harshal Nandurkar in Section 5.3.2.

My overall contribution to the results presented in this thesis is therefore 95%.

Yuekang Xu

PUBLICATIONS

The work presented in this thesis was performed at the Walter and Eliza Hall Institute for Medical Research, under the supervision of Dr. David Tarlinton. Some of the work performed during the period of my PhD has been presented in the following publication:

1. **Xu Y**, Beavitt SJ, Harder KW, Hibbs ML, and Tarlinton DM. (2002). The activation and subsequent regulatory roles of Lyn and CD19 after B cell Receptor ligation are independent. *J Immunol*, 169:6910.
2. Enders A, Bouillet P, Puthalakath H, **Xu Y**, Tarlinton DM, Strasser A. (2003). Loss of the pro-apoptotic BH3-only Bcl-2 family member Bim inhibits BCR stimulation-induced apoptosis and deletion of autoreactive B cells. *J. Exp. Med.* 198:1119.
3. **Xu Y**, Harder KW, Nandurkar H, Hibbs ML and Tarlinton DM. PI3-kinase activity in B cells is negatively regulated by Lyn tyrosine kinase. (manuscript in preparation).

ACKNOWLEDGEMENTS

I would first like to thank my supervisor Dr. David Tarlinton for introducing me into his Lab and giving me the opportunity to fulfil my long-term dream of getting a PhD degree in medical science. His intellectual input, timely encouragement and endless patience make my time in his lab happy and productive. To the rest of the staff in Tarlinton's Lab, I am also grateful for their consistent support. I thank Amenda Light for showing me some basic techniques in cell biology, fellow students Nick Huntington and Kirsten Fairfax for providing assistance to bits and pieces of my experiments.

My thanks would also go to our long-time collaborator, the staff in Hibbs Lab from Ludwig Institute of Cancer Research. Dr. Margaret Hibbs provided a lot of reagents and mice essential for my studies; Dr. Kenneth Harder is generous in giving his intellectual wisdoms; Sarah-Jane Beavitt and Franca Casagrande are very helpful in technical assistance. Our regular meeting with these guys is inspirational.

There are also a number of WEHI staff I would like to thank to, including the FACS staff Catherine Tarlinton and Viki Lapatis who have sacrificed their lunch time in order to extend my FACS sorting time, and the personnel on the 6th floor mice room Kristy Brown and Silvana Liburdi who take good care of our mice and sometimes even kill the mice for me when I have difficulty in taking one out of a full box of dreadful mice. Dr. John Wilkins from Graphic Production Department devoted his free time to show me how to format my thesis. Dr. Jianguo Zhang has given me a lot of help when I was on my L plate with biochemistry experiments. I thank Dr. Yifan Zhan for letting me share with him his Vav interests although the final consequence is that he bought the antibody and I used it for free in my study.

Finally, I am indebted to my family and my parent for their support throughout my studies. My wife gave up her position as an attending doctor in China and accompanied me to Australia. She has covered most of the domestic works in the

family although she herself is doing a PhD in medical science too. My son Tom is also a continuous source of support during my PhD study who often comes with me to the Lab during the weekend, sitting in front of computer or drawing on a piece of paper while I was doing my experiment. Finally I would like to dedicate this thesis to my parent, especially my father, who always has a higher expectation of his son.

ABBREVIATIONS

aa	amino acid
ABTS	2',2'-azinobis(3-ethylbenzthiazoline sulfonic acid) diammonium salt
BASH	B cell adaptor containing an SH2 domain
BCAP	B cell adaptor for PI3K
BCR	B cell receptor
BLNK	B cell linker protein
BSA	bovine serum albumin
BTK	Bruton's tyrosine kinase
CD	cluster of differentiation
CFSE	5, 6 carboxy fluorescein succinimidyl ester
CR	complement receptor
CREB	camp response element binding protein
DAG	diacylglycerol
DME	Dulbecco's Modified Eagle's Medium
DMSO	dimethyl sulphoxide
Dok	downstream of tyrosine kinase
ELISA	enzyme-linked immunosorbent assay
Erk	extracellular-signal regulated kinnase

Fab	fragment antigen binding
FACS	fluorescence activated cell sorter
FCS	foetal calf serum
Fc γ R	Fc γ recetor
FITC	fluorescein isothiocyanate
GAP	GTPase-activating protein
HEM	HEPES Eagle's Medium
HRP	horseradish peroxidase
Ig	immunoglobulin
IP ₃	inositol 1, 4, 5,-triphosphate
Ippt	immunoprecipitation
ITAM	immunoreceptor tyrosine-based activation motif
ITIM	immunoreceptor tyrosine-based inhibitory motif
JNK	c-Jun N-terminal kinase
MAPK	mitogen-activated protein kinase
<i>me</i>	motheaten
<i>me-v</i>	motheaten viable
mIg	membrane bound immunoglobulin
MIRRs	multichain immune recognition receptors
NFAT	nuclear factor of activated T cell

PAG	phosphoprotein associated with glycosphingolipid-enriched microdomins
PBS	phosphate buffered saline
PCR	polymerase chain reaction
PH	plecstrin homology domain
PKB	protein kinase B
PKC	protein kinase C
PLC- γ	phospholipase C gamma
PIR-B	paired immunoglobulin-like receptor B
PI	propidium iodide
PI3K	phosphoinositide 3-kinase
PTK	protein tyrosine kinase
PTP	protein tyrosine phosphatase
RCRB	red cell removal buffer
SFKs	Src family kinases
SH-2	<i>src</i> homology 2 domain
SH-3	<i>src</i> homology 3 domain
SHP-1	SH2-containing protein tyrosine phosphatase 1
SHIP	SH2-containing inositol-5'-phosphatase
SLP-65	SH2 domain-containing leukocyte protein of 65 kDa
SREs	serum response elements
Syk	spleen tyrosine kinase
TCR	T cell receptor

XID	X-linked B cell immunodeficiency
XLA	X-linked agammaglobulinemia
Wt	wild type
WEHI	Walter and Eliza Hall Institute
ZAP-70	zeta-associated protein of 70 kDa

TABLE OF CONTENTS

CHAPTER 1: SIGNALLING ACTIVATION VIA B CELL REDCEPTOR	1
1.1: B CELL ANTIGEN RECEPTOR	1
1.2: PROTEIN AND LIPID KINASE	5
1.2.1: Src protein tyrosine kinses	5
1.2.1.1: The structure of Src PTKs	6
1.2.1.2: The function of Src family PTKs	10
1.2.2: Syk/ZAP-70 PTK	13
1.2.2.1: The structure of Syk/ZAP-70 PTKs	13
1.2.2.2: The function of Syk of Syk/ZAP-70 PTK	14
1.2.3: Btk/Tec family PTKs	18
1.2.3.1: The structure of Btk	18
1.2.3.2: The function of Btk	19
1.2.4: Phosphoinositide 3-kinase	22
1.2.4.1: The classification of PI3Ks	22
1.2.4.2: The structure of class I PI3Ks	23
1.2.4.3: The function of class IA PI3Ks	24
1.2.4.4: The activation of class IA PI3K	30
1.3: SIGNALLING PATHWAYS INITIATED FROM THE B CELL RECEPTOR	34
1.3.1: PLC γ 2 pathway	34
1.3.2: Ras pathway	38
1.3.3: PI3K pathway	41
1.4: REGULATION OF BCR SIGNALLING	45
1.4.1: Positive regulation of BCR signalling by CD19	45
1.4.1.1: The structure of CD19	45
1.4.1.2: The function of CD19	48
1.4.2: Negative regulation of BCR by Lyn	53
1.4.2.1: Phosphorylating negative receptors	53
1.4.2.2: Phosphorylating adaptor molecules	57
1.4.2.3: Kinase-independent inhibition	59
1.4.2.4: Phosphorylating a negative regulatory site on Syk	60
1.5: AIMS OF THIS THESIS	60
CHAPTER 2: MATERIALS AND METHODS	62
2.1: MEDIA	62
2.2: SOLUTIONS AND SUPPLEMENTS	63
2.3: CELL LINES AND MICE	65
2.3.1: B Cell Lines Genotyping	65
2.3.2: Mice Strains	66
2.4: ANTIBODIES	66
2.5: CELL PREPARATIONS	68
2.5.1: <i>In vitro</i> Cell Line Culture	68
2.5.2: Standard Splenic Cell Preparations	68
2.5.3: B Cell Enrichment by Complement Killing	68
2.5.4: B Cell Enrichment by MACS Columns	69
2.5.5: Immunofluorescence Labelling and Flow Cytometry	69
2.6: BIOTINATION OF PROTEINS	69
2.7: LIPID RAFT ISOLATION	70
2.8: CELL BIOCHEMISTRY	70
2.8.1: Cell Stimulation and Lysate Preparation	70
2.8.2: BCA Protein Determination	71

2.8.3: Immunoprecipitation and Western Blotting	71
2.9: PROTEIN AND LIPID KINASE ASSAYS	72
2.9.1: Lyn Kinase Assay using SOP	72
2.9.2: PI ₃ Kinase Assay	73
2.10: PRODUCTION OF ANTIBODY AGAINST CYTOPLASMIC TAIL OF CD19	74
2.10.1: Checking CD19 Inserts from Bacteria	75
2.10.2: Transformation of CD19 containing vector into expression host BL-21	76
2.10.3: Production of GST-CD19 Fusion Protein from Bacteria BL-21	76
2.10.4: CD19 Quantitation and Purification for Immunization	77
2.11: CELL PROLIFERATION ASSAY	78
2.11.1: CFSE labelling	78
2.11.2: Tissue culture	78
2.11.3: Cell division measurement by FACS	78
2.12: CALCIUM FLUX ASSAY	78
2.13: ELISA ASSAY	79
CHAPTER 3: THE ROLE OF LYN IN CD19 MEMBRANE LOCALIZATION	80
3.1: INTRODUCTION	80
3.2: RESULTS AND DISCUSSION	83
3.2.1: Lyn is dispensible for activating BCR signalling	83
3.2.2: Lyn has a weak association with CD19, a positive modulator of BCR	85
3.2.3: CD19 failed to be solublized by non-ionic detergent in Lyn-deficient primary B cells	88
3.2.4: Lipid rafts are signalling platforms, but do not constitutively contain CD19 in the absence of Lyn	93
3.2.5: Cellular purity contributes to the different solubility of CD19 in Lyn ^{-/-} mice	97
3.3: CONCLUSION	102
CHAPTER 4: THE ACTIVATION AND SUBSEQUENT REGULATORY ROLES OF LYN AND CD19 AFTER B CELL RECEPTOR LIGATION ARE INDEPENDENT	104
4.1: SUMMARY	104
4.2: INTRODUCTION	104
4.3: RESULTS	107
4.3.1: CD19 phosphorylation is intact in Lyn-deficient primary B cells	107
4.3.2: CD19 is a substrate of Src family PTK	107
4.3.3: Lyn is not required for CD19 to recruit PI3K and enhance calcium flux after co-ligation with BCR	109
4.3.4: Co-ligation of the BCR with CD19 increases mitogen-activated protein kinase phosphorylation in the absence of Lyn	111
4.3.5: Activation of Lyn and total protein tyrosine phosphorylation after BCR ligation are unaffected by the absence of CD19	115
4.3.6: Lyn-dependent tyrosine phosphorylation of CD22 and FcγRIIB after BCR cross-linking is comparable to that of wild type counterpart in CD19-deficient mice	115
4.3.7: Inhibitory role of CD22 and FcγRIIB is Lyn dependent and CD19 independent	117
4.4: DISCUSSION	120
CHAPTER 5: LYN DOWN-REGULATES PI3K IN PRIMARY MURINE B CELLS	125
5.1: SUMMARY	125
5.2: INTRODUCTION	125
5.3: RESULTS	127

5.3.1: The hyper-responsive phenotype of Lyn ^{-/-} primary B cell was suppressed by PI3K inhibitors	127
5.3.2: PI3K kinase activity is enhanced in the Lyn-deficient primary B cell	129
5.3.3: PI3K pathway is hyper-active in absence of Lyn	134
5.3.4: Lyn inhibits PI3K mediated B cell proliferation	137
5.3.5: Src family kinase are involved in PI3K activation in primary B cell	140
5.3.6: Other Src PTKs contributes to the elevated PI3K activity in Lyn ^{-/-} primary B cells	143
5.4: DISCUSSION	148
CHAPTER 6: GENERAL CONCLUSION	154
6.1: INTRODUCTION	154
6.2: DISCUSSION	155
6.2.1: The role of Lyn in positive regulation of BCR signalling	155
6.2.2: The positive role of CD19 in BCR signalling	157
6.2.3: Negative regulation of BCR signalling by Lyn	158
6.3: CONCLUSION	160
REFERENCES	161

List of Figures and Tables

Figure 1.1: The structure of B cell receptor complex	3
Table 1.1: Expression pattern of Src family protein tyrosine kinase	7
Figure 1.2: Src protein tyrosine kinases	9
Figure 1.3: Structural Characteristics of the ZAP-70 and Syk protein tyrosine kinases	15
Figure 1.4: The structure of Btk in comparison with those of Src and Syk PTKs	20
Figure 1.5: Structural features of phosphoinositide 3-kinase class I family	25
Figure 1.6: PLC- γ pathway	37
Figure 1.7: Ras pathway	40
Figure 1.8: PI3K pathway	44
Figure 1.9: Model of CD19 structure	46
Table 2.1 : Antibodies	66
Figure 3.1: Signal activation through BCR is delayed but still accomplished in absence of Lyn	84
Figure 3.2: CD19 is rapidly tyrosine phosphorylated after BCR ligation	86
Figure 3.3: CD19 positively regulates Erk activation	87
Figure 3.4: Lyn is weakly associated with CD19	89
Figure 3.5: Comparison of different B cell enrichment methods	91
Figure 3.6: CD19 solubilization by different lysis buffer	92
Figure 3.7: Lipid rafts contain the Src PTK Lyn but exclude PTP CD45	95
Figure 3.8: After stimulation, BCR but not SHP-1, is translocated into lipid rafts	96
Figure 3.9: Lipid raft isolation from a Lyn ^{-/-} B cell line	98
Figure 3.10: CD19 is constitutively located outside lipid rafts in both WT and Lyn ^{-/-} B cell	99
Figure 3.11: Cell purity affects the solubilization of CD19 in Lyn ^{-/-} mice	101
Figure 4.1: CD19 phosphorylation in the absence of Lyn	108
Figure 4.2: CD19 is a substrate of Src-family PTK activity	110
Figure 4.3: Recruitment of PI3K to CD19 is intact in lyn ^{-/-} B cells	112
Figure 4.4: Co-ligation of the BCR with CD19 enhances Ca ²⁺ flux in control and lyn ^{-/-} B cells	113
Figure 4.5: Co-ligation of CD19 with the BCR enhances phosphorylation of ERK1/2 in control and lyn ^{-/-} B cells	114
Figure 4.6: Lyn kinase activity, phosphorylation and total protein phosphorylation in control and CD19 ^{-/-} B cells	116

<i>Figure 4.7: Comparison of CD22 and FcγRIIb phosphorylation in Lyn and CD19 deficient mice</i>	<i>118</i>
<i>Figure 4.8: Lyn-dependent inhibition by CD22 and FcγRIIB is intact in CD19^{-/-} B cells ..</i>	<i>119</i>
<i>Figure 5.1: The hyper-responsiveness of Lyn^{-/-} primary B cells after BCR stimulation is corrected by Wortmannin</i>	<i>128</i>
<i>Figure 5.2: Wortmannin and LY294002 have the same inhibitory effect on Erk activation but cause no cell death</i>	<i>130</i>
<i>Figure 5.3: Wortmannin does not inhibit the phosphorylation/activation of Vav</i>	<i>131</i>
<i>Figure 5.4: PI3K-dependent Erk MAP activation does not require Btk</i>	<i>132</i>
<i>Figure 5.5: In vitro PI3K activity is elevated in Lyn -deficient primary B cells</i>	<i>133</i>
<i>Figure 5.6: PI3K pathway is hyper-active in lyn^{-/-} primary B cells—1</i>	<i>135</i>
<i>Figure 5.7: PI3K pathway is hyper-active in Lyn^{-/-} primary B cells—2</i>	<i>136</i>
<i>Figure 5.8: BCAP is hyper-phosphorylated in Lyn -deficient primary B cells</i>	<i>138</i>
Figure 5.9: The hyper-proliferation of Lyn –deficient B cells is inhibited in a dose dependent manner by LY29004	139
<i>Figure 5.10: Elevated Erk MAP kinase activation in Lyn -deficient primary B cells after BCR ligation is inhibited by wortmannin in a dose-dependent manner .</i>	<i>141</i>
<i>Figure 5.11: Src family kinases are involved in PI3K activation</i>	<i>142</i>
<i>Figure 5.12: Other Src PTKs contributes to the elevated PI3K activity in Lyn -/- primary B cells</i>	<i>144</i>
<i>Figure 5.13: The PI3K associated protein is the substrate of Srk PTKs</i>	<i>146</i>
<i>Figure 5.14: A PI3K associated protein is hyper-phosphorylated in the absence of lyn</i>	<i>147</i>
<i>Figure 5.15: Proposed model for inhibition of PI3K activation by Lyn in the context of BCR signalling</i>	<i>151</i>

CHAPTER 1: SIGNALLING ACTIVATION VIA B CELL RECEPTOR

In the battle against a bewildering array of infectious agents, humoral immune mechanisms provide a defensive strategy additional to that provided by the complement-mediated acute inflammatory reaction. Of the numerous soluble plasma proteins in the humoral response to the foreign invasion, antibody is an important constituent of both innate immunity and specific acquired immunity. The production of antibody is a specific function of B lymphocyte and is the final result of a series of signalling events initiated via the antigen receptor on the cell surface, the B Cell Receptor (BCR).

1.1: B CELL ANTIGEN RECEPTOR

As pre-B lymphocytes transit into the immature B cell stage, they begin to express specific receptors that function to recognize foreign antigen and subsequently to process it for presentation to T cells, and to transduce signals that lead ultimately to the production of antibody. This multifunctional receptor on the B cell surface is called B cell antigen receptor (BCR). The BCR belongs to a family of Multichain Immune Recognition Receptors (MIRRs), which includes the T cell receptor (TCR) and receptors for the Fc portions of IgG (Fc γ RI, Fc γ RIIA, Fc γ RIIC, Fc γ RIIIA) and IgE (Fc ϵ RI) (Tamir et al., 1998). The common feature of this receptor family is an oligomeric structure in which different membrane-spanning subunits are used for the purpose of antigen or immunoglobulin recognition and signal transduction. As a member of the MIRRs family, BCR uses surface immunoglobulin (sIg) to sense environmental changes, and employs a disulfide linked Ig α /Ig β heterodimer, noncovalently associated with the sIg, to transduce signals from the BCR to the nucleus in response to external changes.

The sIg on the B cell membrane is a tetrameric complex of Ig heavy (H) chains and light (L) chains. It is derived from the same gene as that of the secreted form of immunoglobulin by alternative RNA processing and therefore has the same antigen specificity, which is determined during B cell development when each B cell somatically recombines the immunoglobulin gene segments to create a unique immunoglobulin

variable region gene. The surface immunoglobulin, however, has a hydrophobic transmembrane domain that anchors it to the surface of the B cell, while the secreted form of immunoglobulin does not. B cells express surface IgM in their immature stages, but as part of their maturation shortly after entering the periphery from the bone marrow, they express both surface IgM and IgD. Class switch recombination occurring during an immune response leads to the appearance of memory B cells that express the other classes of surface immunoglobulin, namely IgG, IgA and IgE. The cytoplasmic domains of sIg are short, ranging from only three amino acid residues in the case of sIgM and sIgD (lysine-valine-lysine-COOH in each case) to 28 residues for the sIgG subclasses (Reth et al., 1992). The longer cytoplasmic domains of IgG and IgE could be related to the efficient responses of memory B cells that use IgG or IgE as their surface immunoglobulin (Kaisho et al., 1997; Achatz et al., 1997; Martin and Goodnow, 2002; Wakabayashi et al., 2002).

The short cytoplasmic domains of surface immunoglobulin requires additional subunits in the BCR complex to transduce signals. During the late 1980s and early 1990s, four publications had a dramatic impact on the research of BCR signalling, of which, three were related to the signal transduction subunit of the BCR complex. These were the discovery of surface proteins associated with sIgM (Hombach et al., 1988); cloning of the *mb-1* gene (Sakaguchi et al., 1988); the description of a YXXL-based motif (single-letter code is used for amino acids, with X denoting any amino acid) conserved in accessory chains of antigen receptors and Fc receptors (Reth, 1989); and the finding that cross-linking the BCR induces cytoplasmic protein tyrosine phosphorylation events (Gold et al., 1990). Later on, the sIgM-associated proteins, now known as Ig α (CD79a) and Ig β (CD79b), were found to be encoded by *mb-1* and *B29* genes respectively (Hombach et al., 1990; Campbell et al., 1991; Schamel et al., 2000). Ig α and Ig β are two disulfide-bonded heterodimers that non-covalently associate with the heavy chains of the sIg (Hombach et al., 1988, 1990; Campbell et al., 1991). The same Ig α /Ig β heterodimer is associated with all of the five different heavy chain classes of murine (Venkitaraman et al., 1991) and human (van Noesel et al., 1992) sIg molecules, but different glycosylation of the Ig α protein has been observed (Campbell et al., 1991; Wienands et al., 1991). The structure of BCR complex is depicted in Fig 1.1.

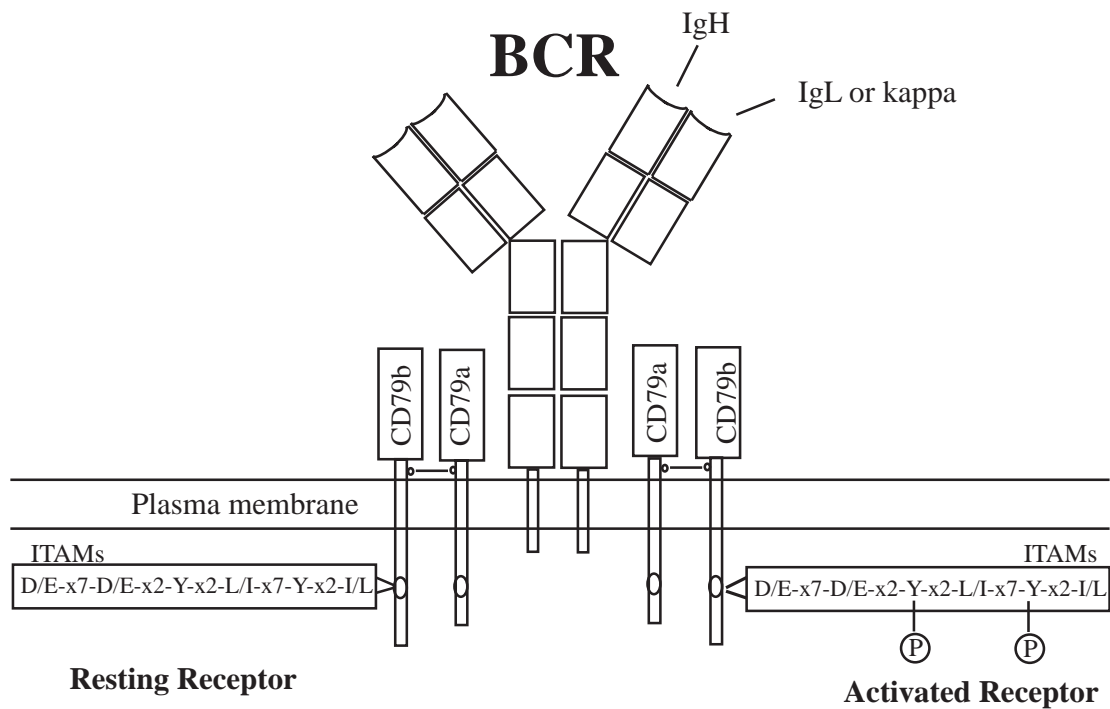

Figure 1.1 The structure of B cell receptor complex. B cell receptor (BCR) is composed of membrane-bound surface immunoglobulin (sIg) and disulfide linked CD79a (Ig α)/CD79b (Ig β) heterodimer, which noncovalently associate with sIg. The phosphorylation state of the Immunoreceptor Tyrosine-base Activation Motif (ITAM) sequences within the Ig α /Ig β subunit are depicted for resting and activated BCR complex.

The signal initiation site on the Ig α and Ig β was first identified by Reth (Reth, 1989). The study of signal function of these sIgM-associated proteins can be summarized in two stages of *in vitro* and *in vivo* experiments. *In vitro*, the biochemical events induced by Ig α and Ig β were mainly determined using a chimeric-molecule approach in the mature B cell line, A20 (Sanchez et al., 1993). In these experiments, Ig heavy chain molecules, carrying a mutation of two conserved polar residues within the transmembrane region, were found to be non-functional. They could neither associate with Ig α /Ig β heterodimers nor cause increases in intracellular Ca²⁺ and tyrosine phosphorylation. However, chimeric immunoglobulin molecules fused to the cytoplasmic tails of Ig α or Ig β (Ig μ /Ig α and Ig μ /Ig β) could reconstitute Ca²⁺ flux. Furthermore, differences between the functions of the Ig α and Ig β tails were observed, in which only the Ig μ /Ig α chimera could reconstitute increase in both Ca²⁺ and tyrosine phosphorylation to levels induced by BCR crosslinking, while the Ig μ /Ig β chimeric molecule reconstituted Ca²⁺ flux only (Sanchez et al., 1993).

The role of Ig α and Ig β in BCR signalling in immature B cells was examined using a B cell lymphoma, WEHI-231. Engagement of the BCR gives both apoptotic and cell cycle arrest signals to the WEHI-231 cells (Benhamou et al., 1990; Hasbold and Klaus et al., 1990). Chimeric molecules, composed of the extracellular and transmembrane portions of the platelet-derived growth factor receptor (PDGFR) and the cytoplasmic tail of either Ig α or Ig β , were introduced into WEHI-231 and found to be capable of inducing apoptosis following PDGF treatment, but only when both were present (Tseng et al., 1997). There was no effect of PDGF on cells transfected with PDGF/Ig α or PDGF/Ig β alone, indicating the involvement of both subunits in the BCR signalling transduction (Tseng et al., 1997).

The *in vitro* data for Ig α and Ig β in signal transduction, however, needed to be supported by *in vivo* experiments, which were mainly done on knockout animals. Ablation of Ig β in mice leads to a complete impairment of B cell development, indicating the importance of this BCR subunit (Gong et al., 1996). Moreover, this block occurs before variable (V_H) to diversity joining (DJ_H) recombination, even before Ig μ is expressed, which suggests that there is a checkpoint that requires Ig β signalling during the V_HD_HJ_H recombination process (Gong et al., 1996; Kurosaki, 1999). The signalling capacity of

Ig α was examined by deleting its cytoplasmic domain. In the cytoplasmic Ig $\alpha^{-/-}$ mice, pre-B cell development was apparently normal, whereas the number of peripheral B cells was decreased tenfold (Torres et al., 1996), suggesting a different developmental stage requirement for signal transduction through Ig α . The most likely explanation for the decreased number of peripheral B cells in cytoplasmic Ig $\alpha^{-/-}$ mice is that the persistence signal through BCR requires both Ig α and Ig β , while Ig β alone is sufficient for pre-B cell development. Collectively, the data from both Ig $\beta^{-/-}$ and conditional Ig $\alpha^{-/-}$ mice emphasize the importance of Ig α and Ig β subunits in BCR signal transduction although the contributions of Ig α and Ig β are not identical and potentially impact different stages of B cell development.

1.2: PROTEIN AND LIPID KINASE

As a major signalling receptor on the B lymphocyte, BCR is used to sense environmental changes outside the cell, and Ig α /Ig β heterodimer to convert such changes into signals, that are transduced into the nucleus in order for the cell to take such actions as proliferation, differentiation or apoptosis. But how are the signals transduced in the cytoplasm? The earliest and immediate response that B cell take after BCR stimulation is a series of biochemical changes which includes phosphorylation of intracellular signalling molecules, increased phosphatidyl inositol (PI) turnover, and calcium mobilization. It is these biochemical cascades that convey signals from the BCR to the nucleus. In terms of phosphorylation, the BCR, however, has no intrinsic Protein Tyrosine Kinase (PTK) activity, making it different from other surface receptors such as cytokine receptors that can phosphorylate tyrosine themselves. To solve this problem, the BCR employs several distinct families of cytoplasmic PTKs and lipid kinases. Indeed, three distinct families of non-receptor PTKs as well as a lipid kinase have been found to be quickly activated upon BCR engagement: These are the Src family of PTKs; Syk of Zap70/Syk family PTKs; Btk of the Tec family of PTKs; and Phosphoinositide 3-kinase (PI3K).

1.2.1: Src Protein Tyrosine Kinases:

Structural analysis of PTKs has revealed at least two classes of enzymes: receptor type kinases which contain extracellular, ligand-binding domains and transmembrane domains; and cytoplasmic non-receptor type kinases which do not have receptor structures at all. The catalytic function of receptor-type kinases is enhanced by ligand-induced dimerization, while non-receptor tyrosine protein kinases lack an intrinsic ability to interact with the extracellular compartment, and therefore participate in ligand-induced intracellular signal transduction responses by associating with the cytoplasmic domains of other cell surface molecules that themselves have no intracellular catalytic domain. The Src-family kinases belong to the non-receptor type kinases, with molecular masses of 55 000 – 60 000. This kinase family includes *Src*, *Yes*, *Fgr*, *Fyn*, *Lyn*, *Lck*, *Hck*, *Blk* and *Yrk*. Members of the c-src gene family can be placed into two groups on the basis to their expression patterns (Brickell, 1992). *Src*, *fyn*, *yes* are ubiquitously expressed (Coutneidge et al., 1993) and *yrk* is observed in a broad range of tissues and cell types (Sudol et al., 1993), whilst expression of the *lyn*, *blk*, *hck*, *lck* and *fgr* genes is restricted to particular hematopoietic cell lineages, as shown in Table 1.

1.2.1.1: Structure of Src PTKs:

Src-related enzymes exhibit a highly conserved primary structure. From the amino-terminus to the carboxy-terminus, the common features of all Src-family members are:

- 1). A membrane association domain, which comprises a myristylation site (glycine 2), a site of palmitoylation (cysteines 3 and /or 5 and /or 6), as well as a cluster of basic residues capable of interacting with acidic phospholipids in the membrane (Resh, 1994).
- 2). A “unique” domain that functions to mediate interactions with specific substrates (Shaw et al., 1989; Turner et al, 1990). The sequence in this domain varies between family members from 50-80 amino acids and represents the most divergent sequence in Src-PTKs. For instance, Lyn exists as two distinct isoforms, referred to as p56^{lyn} and p53^{lyn} that are derived from alternatively spliced mRNA encoding proteins of 512 and 491 amino acid respectively (Yi et al., 1991; Stanley et al., 1991). The difference between the Lyn two isoforms is in the unique domain: p56^{lyn} contains an additional 21 amino acids. While both Lyn isoforms are co-expressed and have been found to be

Table 1.1. Expression Pattern of Src family Protein Tyrosine Kinases

	B cell	T cell	granulocyte	macrophage	mast cell	monocyte
Lyn	+			+	+	+
Blk	+		+	+		+
Hck	+		+	+		+
Lck		+				
Fgr	+		+	+		+
Src			ubiquitously			
Fyn			ubiquitously			
Yes			ubiquitously			
Yrk			ubiquitously			
Ref	1-6	7	3,8	1,8,9	10	1,3,8

1. Yamanashi et al., 1989.

2. Dymecki et al., 1990.

3. Quintrell et al., 1987.

4. Burkhardt et al., 1991.

5. Link et al., 1995.

6. Wechsler et al., 1995.

7. Barber et al., 1989.

8. Ley et al., 1989.

9. Katagiri et al., 1991.

10. Eiseman et al., 1992.

associated with the same cell surface receptor complex, it is possible that they mediate binding to different cell surface receptors through their unique domain sequences, or that they have different affinities for the same receptor complex (Hibbs et al., 1997). 3). A Src-homology-3 (SH3) domain that contains 60 amino acids and interacts with proline-rich polypeptides and is presumably involved in signal amplification (Pawson et al., 1992). For example, most of the signalling adaptor molecules contain proline-rich sequences and they are involved in signal transduction mainly by interacting with SH3 domains (Feng et al., 1994; Lim et al., 1994). 4). A Src-homology-2 (SH2) domain that contains 100 amino acid and has the ability to bind inter- or intra-molecularly to tyrosine phosphorylated proteins (Pawson et al., 1992). The specificity of the binding to phosphorylated tyrosine is regulated by the sequence flanking the SH2 domain (Felder et al., 1993; Panayotou et al., 1993). 5). A catalytic region, the most conserved region between Src family members. It contains sites for ATP binding, phosphotransfer and autophosphorylation. A characteristic feature of the catalytic domain is the presence of a tyrosine residue (Tyr-397 in Lyn) as the autophosphorylation site, which becomes phosphorylated during enzyme activation. 6). A negative regulatory domain at the carboxy-terminus of Src-family members, including the major site of *in vivo* tyrosine phosphorylation. The phosphorylation of a conserved tyrosine residue (Tyr-508) in the regulatory domain of Lyn negatively regulates its tyrosine kinase activity. Current models suggest that in the inactive state, the C-terminal tyrosine in the regulatory domain is phosphorylated by PTK Csk (Okada et al., 1991; Bergman et al., 1992). The interactions among domains, stabilized by binding of the phosphorylated tail to the SH2 domain lock the molecule in a conformation that simultaneously disrupts the kinase active site and sequesters the binding surfaces of the SH2 and SH3 domains. When the C-terminal tyrosine is de-phosphorylated by CD45, - a transmembrane protein tyrosine phosphatase (Cahir McFarland et al., 1993; Hurley et al., 1993), - the SH2 and SH3 domains are freed from the phosphorylated Tyr 508, which promotes enzyme autophosphorylation and hence increases the kinase activity (Sicheri et al., 1997; Xu et al., 1997). The common structural features of Src family protein tyrosine kinases are depicted in Figure 1.2.

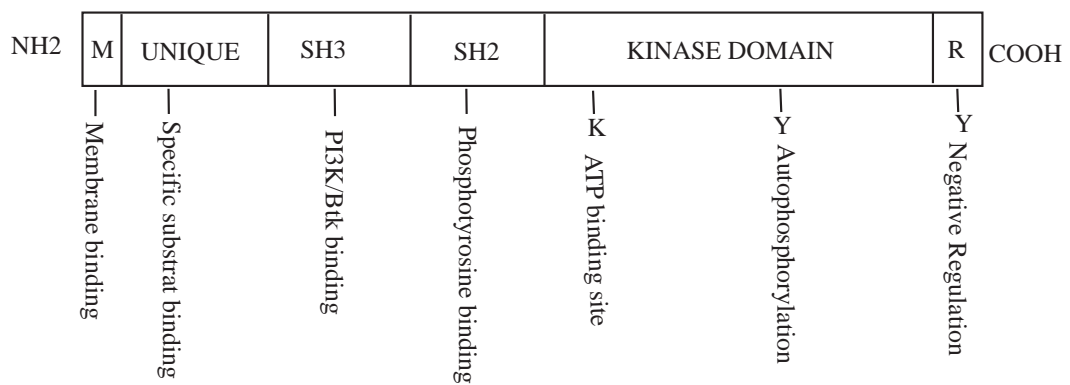

Figure 1.2 Src Protein Tyrosine Kinases. Shown is a schematic representation of the common features of Src family protein tyrosine kinase members. Specific residues in each member vary slightly. The function of each domain is indicated.

1.2.1.2: Function of Src-PTKs in B Lymphocyte:

The functions of Src family PTKs correlates with their physical expression and association. In hematopoietic cells, the Src-PTKs are associated with several surface receptors including integrins, G-protein-coupled receptors, growth factor receptors, BCR, T cell antigen receptor (TCR), the high affinity Fc ϵ RI complex, CD40, Fc γ RI, the lipopolysaccharide receptor, and several cytokine receptors (Erpel et al., 1995). Engagement of these receptors by suitable ligands activates Src family PTKs and thereby starts signal transduction by phosphorylating several target proteins in these receptor pathways. Therefore, the major function of Src-family PTKs is to initiate signalling transduction by phosphorylating substrate molecules.

In B cells, the direct target of phosphorylation by Src-PTK is the Ig α / β subunit in the BCR complex. Ig α and Ig β chains contain a sequence motif of approximately 26 amino acid residues within their cytoplasmic regions. This motif is named the Immunoreceptor Tyrosine-based Activation Motif (ITAM) (Reth, 1989), and is characterized by six conserved amino acids in the sequence D/Ex₇D/Ex₂Yx₂L/Ix₇Yx₂L/I (in single-letter amino acid code, where x represents any amino acid) (Cambier, 1995). The phosphorylation of the two critical tyrosines in the ITAMs in Ig α / β heterodimers creates binding sites for SH2 domain containing molecules involved in the BCR signal transduction cascade. The recruitment of signalling molecules to the Ig α / β subunits brings them into close proximity with the plasma membrane where they can be activated by specific enzymes.

Of these SH2 domain-containing signal transducers recruited to the Ig α / β subunits in the BCR complex, Syk -another non-receptor family of protein tyrosine kinase- is the key molecule phosphorylated by the Src-family PTK (Kurosaki et al., 1994). Following its phosphorylation, Syk becomes activated and starts several important signalling pathways, leading to B cell activation. The function of Syk in BCR signalling will be discussed in detail in the following section of this review.

Other downstream molecules in the BCR signalling pathway that fall into the scope of tyrosine phosphorylation by the Src-family PTKs are some important adaptor proteins in the cytosol. HS1 is a 75-kDa protein encoded by a gene (*hs1*) expressed only in hematopoietic cells. It is mainly localized in the membrane and cytosolic fractions of the

cells. p75HS1 was found to be rapidly phosphorylated and associated with the Src-like kinase Lyn after crosslinking of membrane-bound IgM, making it an important substrate of Src family PTK and possibly other protein-tyrosine kinases upon B cell antigen receptor-mediated signalling (Yamanashi et al., 1993; Fukamachi et al., 1994)

p21ras is a key regulator of cell growth. GTPase-activating protein (GAP) may act as both a regulator of p21ras activity and as a downstream effector of p21ras (Cales et al., 1988; Molloy et al., 1992). Tyrosine phosphorylation of GAP increased rapidly after mIg cross-linking in the immature B cell line WEHI 231, the mature B cell lines BAL 17 and Daudi and the IgG-bearing B cell line A20, which showed p21ras GAP to also be a substrate for mIg-activated tyrosine kinases. (Gold et al., 1993). Furthermore, the GAP associated protein that migrates at 62 kDa by SDS-PAGE (p62^{dok}) was isolated in the hematopoietic progenitors from chronic myelogenous leukemia (CML) patients, and was found to be constitutively tyrosine phosphorylated (Carpino et al., 1997). Later on, p62^{dok} was proven to be tyrosine phosphorylated in a Lyn-dependent manner upon cross-linking of BCR or BCR with Fc γ RIIB and plays a negative role in various BCR signalling situations (Tamir et al., 2000; Yamanashi et al., 2000).

Further substrates phosphorylated by the Src family protein tyrosine kinases include Bruton tyrosine kinase (BTK), a protein tyrosine kinase involved in phosphorylation of phospholipidase C gamma 2 (PLC- γ 2). (Kawakami et al., 1994; Aoki et al., 1994); CD19, a co-receptor of BCR that promotes B cell signalling (Chalupny et al, 1993; van Noesel et al, 1993;); and CD22, an adhesion molecule that is implicated in calcium inhibition in B cells (Schulter et al., 1992; Chen et al., 1998; Cornall et al., 1998; Smith et al., 1998).

Apart from phosphorylating downstream molecules in the signalling cascade as a tyrosine kinase, the Src-family PTKs also have a role independent of this activity. The SH3 domain of the Src-family PTKs, for example, has the ability to interact with proline-rich peptides contained in most of the cytoplasmic signalling molecules. This interaction either directly activates these molecules or brings them close to plasma membrane to be activated. One such target molecule is the 85 kD sub-unit of PI3 kinase, which is reported to interact with the SH3 domain of p53/56^{lyn} and p59^{fyn} (Pleiman et al., 1994; Karnitz et al., 1994). The binding of the SH3 domain of Lyn and Fyn to the purified PI3 kinase led to a five-to-seven fold increase in the specific kinase activity of PI3

kinase. Moreover, the ligand-induced receptor activation of PI3 kinase was blocked by a peptide containing residues 84 to 99 of p85, the regulatory subunit of PI3 kinase (Pleiman et al., 1994), which further supports the idea that interaction of the SH3 domain of Src-family PTKs with PI3 kinase can regulate the enzymatic activity of the latter. A second documented target for the SH3 domain of Src-related molecules is the Tec family of tyrosine protein kinases, the third non-receptor PTK in hemopoietic cells, which includes Tec and Btk. By utilizing the glutathione S-transferase (GST)-fusion system, the C-terminal half of the Tec N-terminal unique domain was found to bind p53/56^{lyn} constitutively, with the binding domain of Lyn localized to its SH3 domain (Mano et al., 1994). Btk was also reported to be capable of associating with the SH3 domain of not only p53/56^{lyn}, but also p59^{fyn} and p56/59^{Hck} with the interactions mediated by two 10-amino acid long motifs in Btk. (Cheng et al., 1994). Finally, the SH3 domains of Src family PTKs can also associate with some multifunctional adapter proteins to enrich Src-PTK's importance as an essential molecule in the hemopoietic lineage. A 62 kDa tyrosine-phosphorylated protein that associates with p21ras GTPase-activating protein was identified as a Src family kinase SH3-domain-binding protein in the yeast two-hybrid system (Richard et al., 1995). Reconstitution of complexes containing p62 and the src family kinase p59^{fyn} demonstrated that formation of such a complex resulted in tyrosine phosphorylation of p62 and this phosphorylation required an intact SH3 domain of p59^{fyn} (Richard et al., 1995).

The major obstacle in addressing the function of Src family PTKs in general is the apparent redundancy among individual family members. To overcome this problem, a Blk, Fyn and Lyn triple-deficient mouse, referred to as Src Family Kinase-deficient (SFK-deficient) was recently generated (Saijo et al., 2003). Although this defect was not associated with impaired tyrosine phosphorylation of known key signalling molecules such as Ig α , Ig β and Syk in the pre-B cells, the absence of Blk, Fyn, and Lyn completely abrogated pre-BCR-mediated NF- κ B activation, which was unaffected in Syk-deficient pre B cells (Saijo et al., 2003). Furthermore, the link between Src family PTKs and NF- κ B activation in pre-B cells was localized to the atypical PKC- λ , whose phosphorylation is greatly reduced in the absence of Blk, Fyn, and Lyn (Saijo et al., 2003). Although the analysis of signalling events in mouse mature B cells with such SFK-deficiency needs to be done in the future, these results suggest an independent role of Src family PTKs from that of Syk in early B cell development.

1.2.2: SYK/ZAP-70:

Following receptor engagement and phosphorylation of the ITAMs by Src-family PTKs, a second class of cytosolic PTKs, the Syk/ZAP-70 family of PTKs, is recruited to the antigen receptor complex. Syk (spleen tyrosine kinase) was initially purified as a novel 40 kDa PTK from soluble extracts of bovine thymus, but it later turned out that this protein was actually derived from a larger 72 kDa protein (Syk) that was highly susceptible to proteolytic degradation (Law et al., 1994; Taniguchi et al., 1991; Zioncheck et al., 1986). Cloning of porcine and human Syk revealed a new class of non-receptor PTKs (Taniguchi et al., 1991; Law et al., 1994). As opposed to the discovery of Syk, the identification of ZAP-70 was closely related to its functional characteristics. ZAP-70 was first isolated as a 70 kDa tyrosine phosphorylated protein associated with the tyrosine phosphorylated TCR ζ chain following TCR ligation (Chan et al., 1991). It was therefore designated as zeta-associated protein of 70 kDa (ZAP-70) (Chan et al., 1991). ZAP-70 has approximately 73% amino acid sequence homology with Syk, but their expression pattern is quite different. ZAP-70 was reported to be expressed in T cells and NK cells (Chan et al., 1992; Chan et al., 1994) and recently also found throughout B cell development (Schweighoffer et al., 2003). Although Syk protein is present in all major thymocyte subsets, its expression level is down-regulated threefold to fourfold in peripheral T cells. In contrast to ZAP-70, expression of Syk is 12- to 15-fold higher in peripheral B cells when compared with peripheral T cells (Taniguchi 1993; Chan et al., 1994). Besides, Syk was also reported in macrophages (Greenberg et al., 1994) and later in dendritic cells (Fanger et al., 1997). Therefore, Syk is mainly expressed in B cell and has a broader expression pattern than that of ZAP-70 (Law et al., 1994).

1.2.2.1: The Structure of Syk/ZAP-70 PTKs

As a non-receptor protein tyrosine kinase, the structure of Syk/ZAP-70 family PTKs is slightly different from that of Src family. At the amino terminus, the Syk/ZAP-70 family of PTKs have no putative sites of N-myristylation. Although this family of PTKs also

have two SH2 domains, they have no Src-homology 3 (SH3) domains. Following the two tandem amino-terminal SH2 domains is an extended interdomain region, which is important in regulating the kinase activity of these proteins. These interdomain regions of Syk and ZAP-70 show about 30% sequence identity. Like Src-family PTKs, the Syk/ZAP-70 kinases also have a well-conserved catalytic enzyme domain. ZAP-70 contains the amino acids YTAR, a sequence identical to the autophosphorylation motif of the Src-family PTKs (Cooper et al., 1993), while the corresponding region in Syk comprises the amino acid sequence YKAQ. At the COOH-terminus, Syk/ZAP-70 PTKs do not contain negative regulatory tyrosine phosphorylation sites that are evident in the Src-family PTKs. (Fig 2.2.2).

Both of the tandem SH2 domains in Syk/ZAP-70 kinases were shown to be required to bind to the two, properly spaced, phosphotyrosyl residues of ITAMs in the antigen receptor complex (Chan and Shaw, 1995; Hatada et al., 1995), and the binding of Syk to phosphorylated tyrosines in the ITAMs is a crucial step in its activation (Pao et al., 1998). Auto-phosphorylation of Syk occurs *in vitro* on several tyrosine residues (Furlong et al., 1997; Keshvara et al., 1997), at least two of which -Y518 and Y519- are located within the activation loop of the catalytic domain and have been identified as *in vivo* phosphorylation sites (Couture et al., 1996). Mutation of either or both these residues to phenylalanine blocked the normally observed tyrosine phosphorylation of many cellular proteins (Couture et al., 1997). Sequences of phosphorylation sites located within the hinge region predict that Syk serves as a docking site for other SH2 domain-containing proteins. Consistent with this prediction, auto-phosphorylated Syk efficiently binds the carboxyl terminal SH2 domain of phospholipase C- γ 1 (Furlong et al., 1997).

1.2.2.2: The Function of Syk of Syk/ZAP-70 PTKs

The importance of Syk to several organ systems including the immune system is supported by the fact that Syk-deficient mice die perinatally (Cheng et al., 1995;

ZAP-70**SYK**

Figure 1.3: Structural Characteristics of the ZAP-70 and Syk Protein Tyrosine Kinases.

Schematic representation of ZAP-70 and Syk N-terminal (SH2-N) and COOH-terminal (SH2-C) Src-homology 2 domains and the catalytic kinase domain (Kinase). Amino acid sequence numbers are labelled above their corresponding positions.

Tybulewicz et al., 1998). Study of the Syk^{-/-} lymphoid cells showed that the Syk mutation impaired the differentiation of B-lineage cells, apparently by disrupting signalling from the pre-BCR complex and thereby preventing the clonal expansion, and

further maturation, of pre-B cells (Cheng et al., 1995). The early death of Syk – deficient mice has made the investigation of the immune system in these mice problematic. However, analysis of donor B lineage cells in radiation chimeras reconstituted with fetal liver from Syk-deficient mice showed a block in B-cell receptor signalling (Turner et al., 1995). Despite the production of small numbers of immature B cells, Syk-deficient radiation chimaeras failed to accumulate mature B cells, indicating a role for this protein in the production or maintenance of mature B cells (Turner et al., 1995).

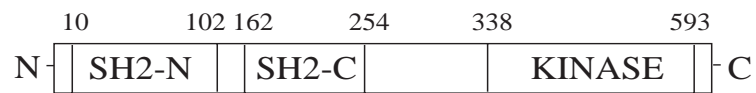
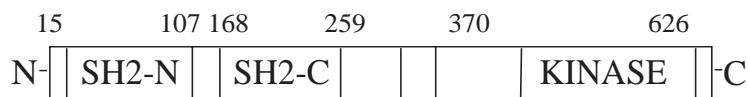
The roles that Syk plays in signal transduction from the BCR have been analysed most extensively in a cell line using targeted gene disruption. Reconstitution of DT40 cells, rendered Syk-deficient by homologous recombination, with the wild-type but not the kinase-dead Syk, led to a complete restoration of BCR-mediated signalling (Kurosaki et al., 1994; Takata et al., 1994), indicated the necessity of this non-receptor kinase in BCR signalling pathway. In terms of signalling initiation, Syk was recently found to phosphorylate both tyrosines in the ITAMs of BCR complex, while Lyn phosphorylates only the first tyrosine (Rolli et al., 2002). Distinct from the Src-family member Lyn, deletion of Syk in DT40 B cell line abolished BCR-induced tyrosine phosphorylation of phospholipase C-gamma 2 (PLC γ 2), resulting in the loss of both inositol 1,4,5-trisphosphate (IP3) generation and calcium mobilization, demonstrating a critical role for Syk in phosphorylating and activating PLC γ 2 (Takata et al., 1994). Since PLC γ 2 is involved in the activation of the phosphatidylinositol pathway, its role in BCR signalling has been examined by generating a PLC γ 2-deficient DT40 cell line (Takata et al., 1995). Cross-linking sIgM on the PLC γ 2-deficient cells evoked neither inositol 1,4,5-trisphosphate nor calcium mobilization, which supported the argument that PLC γ 2 is the upstream phospholipase that causes inositol 1,4,5-trisphosphate generation and calcium mobilization. However, in the PLC γ 2-deficient or Syk-deficient DT40 B cells, the induction of apoptosis was also found to be blocked but still observable in Lyn-deficient B cells (Takata et al., 1995). These results indicate that activation of PLC γ 2 through Syk is required for sIgM-induced apoptosis.

Following PLC γ 2, several other intracellular signalling proteins including Vav, HS1, and Shc, (Deckert et al., 1996; Brunati et al., 1995; Harmer et al., 1997) have been identified as functional substrates of Syk. Vav is a proto-oncogene exclusively expressed in

hematopoietic cells. In the yeast two-hybrid system, Syk was found to phosphorylate Vav. Furthermore, the interaction between Syk and Vav is antigen receptor stimulation dependent and involves the SH2 domain of Vav and tyrosine residues located in a region of Syk between its C-terminal SH2 and kinase domains (Deckert et al., 1996). BCR-induced tyrosine phosphorylation of Shc induces it to form a complex with another adapter molecule, Grb2, and the Ras guanine nucleotide exchange factor, Sos, which is believed to lead to the activation of Ras (Bonfini et al., 1992). Syk was demonstrated to be the protein tyrosine kinase responsible for the phosphorylation of Shc in stimulated B cells, and the Syk-phosphorylated Shc possesses two Grb2 binding sites, which are required for efficient formation of Shc-Grb2-Sos complexes *in vitro* and *in vivo* (Harmer et al., 1997).

Though it was clear from the above studies that Syk stimulates PLC γ 2, Vav and Shc, the mechanism by which these events occur remained obscure until the identification of a particular cytosolic adaptor protein. Fu *et al* first cloned the gene encoding the adaptor in mouse and man, which they named BLNK (B cell linker protein) (Fu and Chan, 1997). In the same year, another group independently cloned the mouse gene, which they called SLP-65 (SH2-domain-containing leukocyte protein of 65 kDa) (Wienands et al., 1998) and later a chicken homologue was also cloned (Goitsuka et al., 1998) and termed BASH (B cell adaptor containing an SH2 domain). In spite of the different terminology, the new molecule turned out to be a novel adaptor protein that linked Syk to many downstream signalling events. After BCR cross-linking, BLNK/SLP-65 is rapidly tyrosine-phosphorylated by Syk. The phosphorylated BLNK provides docking sites for several SH2-containing effector molecules, forming a signalling complex involving PLC γ 2, Grb-2 and Vav that, in turn, permits the phosphorylation and/or activation of their respective signalling pathways (Zhang et al., 1998; Ishiai et al., 1999).

Most of the BCR signalling occurs in plasma membrane microdomains called lipid rafts, in which diverse signalling pathways are assembled (Cheng et al., 1999; Petrie et al., 2000). The prominent role of Syk in early BCR signalling is further supported by the finding using a microscopic visualization approach that Syk is rapidly translocated into lipid raft domains (Gupta et al., 2003). Although inconsistent with a previous study (Cheng et al., 1999), in which biochemical purification of lipid rafts might have disrupted native protein-protein interaction, this result provided physical evidence for the

accessibility of Syk to the antigen receptor, the Src family PTKs and other signalling molecules in the early stages of signalling.

1.2.3: BTK

The third class of non-receptor cytoplasmic tyrosine kinases involved in B cell signal transduction, other than Src family and Syk/ZAP-70 family PTKs, is the Tec family of protein tyrosine kinases, which consists of Bruton's tyrosine kinase (Btk) (Tsukada et al., 1993; Aoki et al., 1994); Tec (Mano et al., 1990; Mano et al., 1993); Itk (Siliciano et al., 1992; Tanaka et al., 1993), as well as the less homologous Txk kinase (Haire et al., 1994). Btk was initially identified as the target of mutations responsible for the genetic defects associated with X-linked agammaglobulinemia (XLA) in man, and X-linked B cell immunodeficiency (XID) in mice (Tsukada et al., 1993; Rawlings et al., 1993). The expression of Btk is preferentially in cells of the B lymphoid and myelomonocytic lineages, but not in T cells where Itk is the predominant Tec family PTK (Tsukada et al., 1993; Vetrie et al., 1993; Siliciano et al., 1992).

1.2.3.1: The Structure of Btk

Like the Src-family PTKs, Bruton's tyrosine kinase contains classical SH1, SH2 and SH3 domains in tandem (amino acid residue 215-279, 280-376 and 377-659 respectively), which is different from the Syk/ZAP-70 family kinases in that they contain tandem SH2 domains but lack an SH3 region. The SH2 and SH3 domains are highly conserved in all Tec family PTKs. These noncatalytic domains exist among a series of cytoplasmic signalling proteins including PLC- γ , Ras GTPase (guanosine triphosphatase)-activating protein, and Src-like tyrosine kinases, with SH2 domains binding to tyrosine phosphorylated proteins and SH3 binding to proline rich motifs. The formation of these heteromeric signalling protein complex at or near the plasma membrane links the kinases to specific target proteins (Koch et al., 1991; Pawson et al., 1992; Birge et al., 1993). The Btk PTK differs from the Src-related kinases in its lack of a negative regulatory phosphorylation site and in the absence of an amino-terminal myristylation site (Tsukada et al., 1993; Vetrie et al., 1993). Amino-terminal

myristylation results in constitutive membrane association of all Src-family kinases (Resh, 1994), while lack of the myristylation signal lead to the majority of the Btk protein remaining in the cytoplasm, which indicates that translocation from the cytosol to the cell membrane may be a critical feature in the activation of Btk.

The most distinctive feature of Btk is the presence of an amino-terminal pleckstrin homology (PH) domain (amino acid residue 1-137), followed by cysteine-rich and proline-rich regions that together comprise the Tec homology (TH) domain (amino acid residue 138-214) (Vihinen et al., 1994). The PH domain is highly conserved between the Tec family members, and was implicated in translocating Btk to the plasma membrane (Hemmings, 1997), which is both essential (Kasakami et al., 1994; Li et al., 1995) and sufficient for its activation (Li et al., 1997a). The proline rich sequence in the TH domain may function as a ligand involved in SH3 mediated interaction with Src-family proteins and other SH3 containing proteins (Cheng et al., 1994; Mano et al., 1994).

1.2.3.2: The Function of Btk

Evidence obtained from the analysis of BCR signalling in the chicken B cell line DT40 indicates the involvement of Btk in phospholipase dependent signalling. Disruption of the Btk locus in DT40 cells caused a significant reduction in the tyrosine phosphorylation of PLC- γ 2 upon BCR stimulation, leading to the loss of both inositol 3,4,5-trisphosphate (IP3) generation and calcium mobilization in response to BCR cross-linking. Furthermore, the PH and SH2 domains of Btk were found to be required for PLC- γ 2 activation (Takata et al., 1996). In addition, activation of the μ isoform of PKC (PKC μ) downstream of PLC- γ 2 in DT40 cells after BCR engagement was partially reduced by the disruption of Btk (Sidorenko et al., 1996), further supporting the regulatory role of Btk in phosphatidylinositol hydrolysis and calcium mobilization.

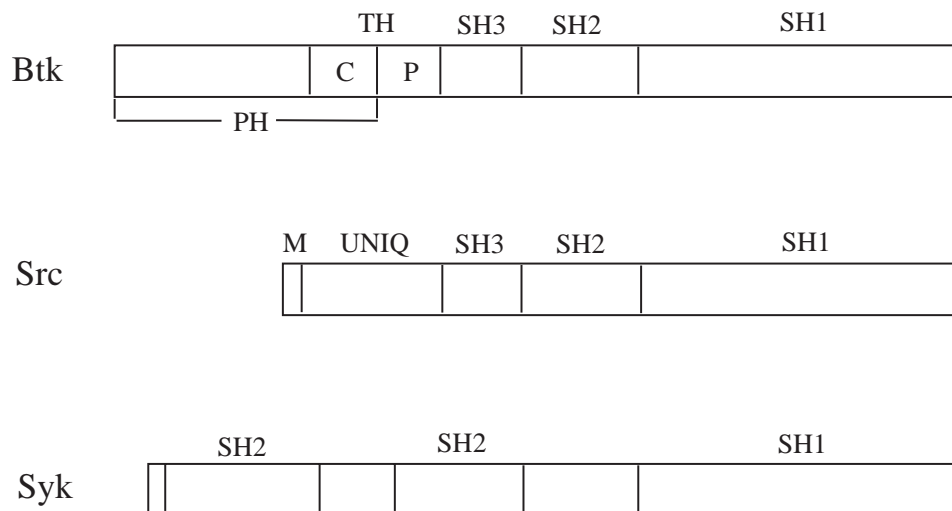

Figure 1.4: The Structure of Btk in comparison with those of Src and Syk PTKs.

PH, TH, SH1, SH2 and SH3 domains are indicated by the labels above the boxed regions in each protein. The cysteine-rich and proline-rich regions of the Btk TH domain are designated C and P respectively. UNIQ represents the unique region of Src family PTKs.

Research on DT40 cells also showed that apart from the phospholipase-dependent response, Btk may have a role in apoptosis induction. After exposure to radiation, DT40 cells undergo apoptosis (Yang et al., 1995), as they do in response to BCR crosslinking. While this radiation-induced apoptosis occurred in Lyn and Syk disrupted B cells, it was

completely abolished in the Btk disrupted B cells (Uckun et al., 1996), indicating an requirement for Btk in these process among the three important non-receptor PTKs. Furthermore, the kinase domain of Btk was identified to be responsible for triggering radiation-induced apoptosis in B lymphoma cells because introduction of the human *btk* gene mutated either in SH2 domain or PH domain (but not a kinase domain mutant) into the Btk-deficient cells restored the apoptotic response to radiation (Uckun et al., 1996).

Recent studies on Btk function suggest that this non-receptor PTK may play a direct role in affecting gene transcription. Like other Tec family members, Btk has been shown to interact with transcription factors (Lewis et al., 2001). In ectopically as well as endogenously Btk-expressing cells, Btk was reported to translocate to the nucleus in response to external stimulation (Mohamed et al., 2000). A direct impact of Btk on gene expression is further supported by an *in vitro* finding that BAP/TFII-I, a protein implicated in transcriptional regulation (Roy et al., 1997), is a substrate for Btk and is hyperphosphorylated on tyrosine upon co-expression with Btk in mammalian cells (Egloff et al., 2001).

Mutations in *btk* have been linked to the severe early B cell developmental blocks in human XLA and to the milder B cell activation deficiencies in murine XID (Tsukada et al., 1993; Rawlings et al., 1993). To elucidate the potential Btk functions in mice, a Btk-deficient mouse line was generated by gene targeting in embryonic stem cells and assayed by RAG2-deficient blastocyst complementation (Khan et al., 1995). The blocked expression of Btk lead to reduced numbers of mature conventional B cells, severe B1 cell deficiency, serum IgM and IgG3 deficiency, and defective responses *in vitro* to various B cell activators and *in vivo* to immunization with thymus-independent type II antigens, indicating an important role of Btk in splenic B cell proliferation (Khan et al., 1995). Further analysis of the Btk knockout model suggested that Btk is not essential for pre-B cell receptor signalling in the mouse, but Btk-mediated B cell receptor signalling appears to be required for the survival of immature B cells in the bone marrow, development of peripheral B cells, including follicular entry, follicular maturation and plasma cell differentiation (Maas et al., 2001).

1.2.4. Phosphoinositide 3-kinase

Apart from protein tyrosine phosphorylation, phosphatidylinositol (PtdIns) turnover can also carry a powerful signal. Phosphoinositide 3-kinases (PI3Ks) are an evolutionarily conserved family of signal transducing enzymes that phosphorylate the D3 position of the inositol ring of phosphoinositides and produce PtdIns (3)P, PtdIns (3,4)P₂, and PtdIns (3,4,5)P₃. A great variety of stimuli activate PI3Ks, leading to the transient accumulation of these lipid products in cell membranes, which then serve as second messengers to regulate the location and activity of an array of downstream effector molecules.

1.2.4.1: The Classification of PI3Ks

Since the discovery of a PI3K activity in 1988 (Whitman et al., 1988), nine members of the PI3-K families have been isolated from mammalian cells. According to the molecules that they preferentially utilize as substrates, PI3Ks are grouped, as suggested by Domin and Waterfield, into three classes (Domin and Waterfield, 1997): Class I (IA and IB), Class II and Class III.

Class I PI3Ks utilize PtdIns (PI), PtdIns(4)P (PI4P) and PtdIns(4,5)P₂ (PI(4,5)P₂) as substrates *in vitro*, but in cells, their preferred substrate is PI(4,5)P₂ (Stephens et al., 1993; Woscholski et al., 1997). Class I PI3Ks are further subdivided into class IA and IB enzymes according to the different upstream molecules. Class IA PI3Ks signal downstream of tyrosine kinases while Class IB PI3K work under heterotrimeric G-protein-coupled receptors (Fruman et al., 1998). All mammalian cell types investigated express at least one class IA PI3K isoform, and stimulation of almost every receptor that induces tyrosine kinase activity also leads to class IA PI3K activation (Stephens et al., 1993; Fry, 1994; Wymann et al., 1998).

Class II PI3Ks are large molecules (> 170 kDa). This class of PI3Ks have a lipid substrate specificity clearly distinct from that of class I and class III enzymes. *In vitro* class II PI3Ks can use PI, PI(4)P, and PI(4,5)P₂ as substrates, with a strong preference for PI>PI(4)P>>>PI(4,5)P₂ (MacDougall et al., 1995; Domin et al; 1997). In contrast to class I PI3Ks which are mainly cytosolic, class II PI3Ks are predominantly associated with the membrane fraction of cells (Arcaro et al., 1998; Prior et al., 199).

Class III PI3Ks are the homologues of the yeast vesicular protein-sorting protein Vps34p (Herman et al., 1992). These PI3Ks can only use PI as a substrate *in vitro* and they are most likely responsible for the generation of a large fraction of the PI(3)P in cells. The fact that cellular levels of PI(3)P remain quite constant suggests that the physiological processes in which class III PI3Ks are involved are not triggered by cellular stimulation.

Of the three classes of PI3Ks, class I PI 3Ks are the best understood in their role in leukocyte signalling pathways and therefore their structures will be discussed in detail.

1.2.4.2: The Structure of Class I PI3Ks

Class I PI3Ks are heterodimers made up of an ~ 110 kDa catalytic subunit (p110) and a tightly associated adaptor/regulatory subunit. The class IA PI3Ks have three catalytic isoforms (p110 α , p110 β , or p110 δ), and five regulatory isoforms (p85 α , p85 β , p50 α , p55 α , or p55 γ). The regulatory units p85 α , p85 β , and p55 γ are encoded by distinct genes, while p50 α and p55 α are produced from alternate transcripts of the p85 α gene. Each of the regulatory isoforms in class IA molecules contains two SH2 domains that mediate binding to phosphotyrosine residues in the sequence motif pYxxM (x represent any amino acid). Together with other protein-interaction domains in the catalytic and regulatory subunits, which will be described later, the SH2 domains help recruit the class IA PI3Ks to membrane-associated signalling complexes following tyrosine kinase activation. Between the two SH2 domains is a region that is necessary and sufficient for interaction with the N terminus of p110 catalytic subunits (Klippel et al., 1993). This region, referred to as the inter-SH2 domain, contains sequences that are predicted to form α -helices that fold into a coiled-coil structure (Klippel et al., 1993). In addition to the SH2 domain, p85 α and p85 β possess an N-terminal SH3 domain, two or three proline-rich segments and a region of homology to GTPase-activating proteins for the rho family of small G proteins (rho-GAPs) (Koyama et al., 1993; Vanhaesebroeck et al., 1999).

The three catalytic subunits of class IA PI3Ks, p110 α , p110 β , and p110 δ , share 42-58% amino acid sequence identity (Hiles et al., 1992; Hu et al., 1993; Vanhaesebroeck et al., 1997). Each of these proteins contains an N-terminal region that interacts with regulatory subunits, a domain that binds to the small G protein ras, a phosphoinositide

kinase (PIK) domain homologous to a region found in other phosphoinositide kinases, and a C-terminal catalytic domain. p110 α and p110 β , are widely distributed in mammalian tissues, while p110 δ shows a more restricted distribution and is mainly found in leukocytes (Vanhaesebroeck et al., 1999).

The only class IB PI3K that has been identified so far is the p110 γ catalytic subunit complexed with a 101-kDa regulatory protein (p101) (Stephens et al., 1994). The p110 γ contains a PIK domain and a ras-binding domain but diverges from class IA PI3Ks at its N terminus and does not interact with p85 proteins (Stoyanov et al., 1995; Stephens et al., 1997). The unique regulatory subunit of class IB PI3K, p101, possesses no recognizable homology to other proteins (Stephens et al., 1997). The regions of interaction between p101 and p110 γ have not been mapped. The structural domains of Class IA and IB PI3Ks are depicted in Fig 1.5.

1.2.4.3: The Function of Class IA PI3K

Much attention has been paid to class IA PI3Ks since they were found to be the isoforms that signal downstream of tyrosine kinases. In B cells, this class of PI3Ks is rapidly activated by BCR engagement. Although all of the class I PI3Ks phosphorylate PI, PI(4)P, and PI(4,5)P2 *in vitro* as has been mentioned above, PI(4,5)P2 is the predominant substrate in cells and therefore the major product of the kinases is PI(3,4,5)P3 (Toker et al., 1997). The major function of PI3K is realized via its lipid product, PIP3, which can recruit signalling proteins to the plasma membrane through their PH domains (Lemmon et al., 1998; Leervers et al., 1999). Once at the plasma membrane, these cytosolic proteins or enzymes are further activated by their respective

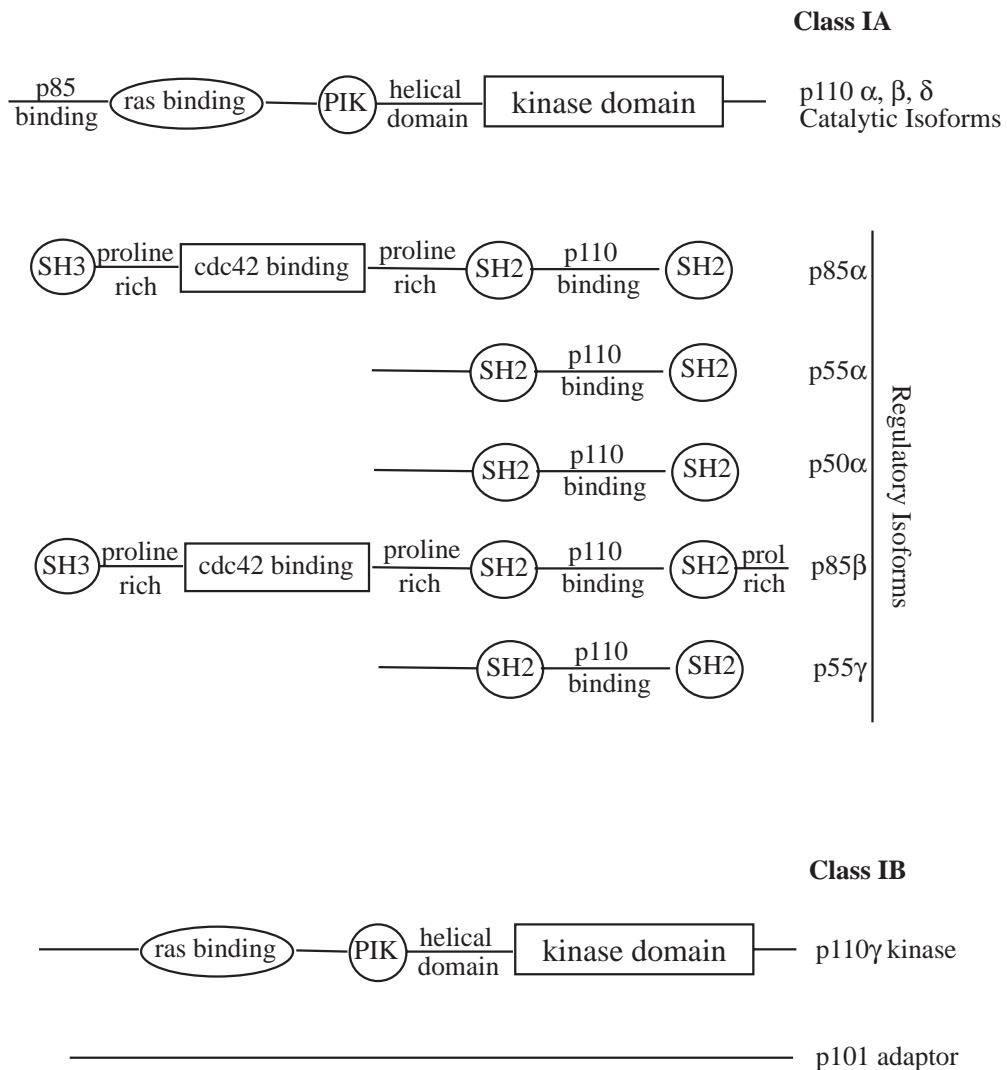

Figure 1.5 Structural features of phosphoinositide 3-kinase (PI3K) Class I family members. Class I PI3Ks is further subdivided into class IA and IB based on the associated regulatory subunit. The class IA catalytic isoforms associate interchangeably with five regulatory isoforms in which p85 α , P55 α and p50 α are encoded by alternative transcripts of a single gene.

kinases and subsequently initiate a series of signalling cascades that lead to such events as calcium flux, cell survival and proliferation (Leever et al., 1999).

Calcium Flux

Of the several PH domain-containing proteins that are known to be targets of PI3K in B cells, the Tec family PTK Btk is an important one implicated in calcium flux control (Rawlings et al., 1996; Rawlings, 1999). PIP3 binds with high affinity to the PH domain of Btk, recruiting it to the plasma membrane. There it can be activated by membrane-associated Src family kinases that phosphorylate Y551 in the activation loop, and this activation is dependent on an intact Btk PH domain (Li et al., 1997; Nisitani et al., 1999). Additionally, the lipid product generated by PI3K was also reported to directly increase Btk activity by binding to the PH domain of Btk and thereby relieving an inhibitory interaction between the PH and kinase domains (Saito et al., 2001). A critical substrate of Btk is PLC γ 2 (Fluckiger et al., 1998). After being brought together by the scaffolding protein BLNK, Btk can phosphorylate and maximise the activation of PLC- γ 2 (Fu et al., 1998; Hashimoto et al., 1999). In addition, PI3K may contribute to recruitment of PLC- γ 2 via direct interactions of PIP3 with the SH2 and/or PH domains of PLC- γ 2, indirectly activating PLC- γ 2 in the absence of its tyrosine phosphorylation (Bae et al., 1998; Falasca et al., 1998). After being fully activated by Btk under the influence of PI3K, PLC- γ 2 produces the second messenger I(3,4,5)P3 to increase calcium flux in the cytoplasm (Berridge et al., 1984).

The above model for PI3K to enhance intracellular calcium flux is supported by pharmacological and gene targeting approaches. The treatment of primary B cells with wortmannin, a drug that specifically inhibits the activity of PI3K (Arcaro et al., 1993), attenuates BCR-mediated calcium flux (Buhl et al., 1997), while over-expression of Btk and PI3K enhances PLC- γ 2 phosphorylation and the sustained phase of calcium flux (Scharenberg et al., 1998), indicating the promoting effect of PI3K in the calcium pathway. Finally, knockout models of different subunits of PI3K confirm the requirement of PI3K for elevated calcium flux *in vivo*. Jou *et al* recently generated a mutant mouse in which the gene encoding p110 δ , one of the three p110 catalytic subunits of class IA PI3Ks, was disrupted in murine ES cells (Jou et al., 2002). Among the immune-deficiencies in these mutant mice, the IgM-induced calcium flux was found

to be attenuated to around 25 % of the wild type control (Jou et al., 2002). Collectively, these results strongly indicate an essential role for PI3K in the calcium pathway in B cell.

Cell Proliferation and Survival

In the past three or four years, the subunits of PI3Ks have been genetically disrupted in mice in an attempt to fully understand the role of these lipid kinases *in vivo*. The regulatory subunit of PI3Ks increases the thermal stability of the catalytic subunits (Yu et al., 1998) and regulates the association of the enzyme with membrane-associated signalling complexes (Klinghoffer et al., 1996). To further define the function of these subunits mice lacking p85 α (Suzuki et al., 1999; Terauchi et al., 1999) or p85 α together with its two spliced variants p55 α and p50 α (Fruman et al., 1999; Fruman., 2000) have been generated. While p85 α ^{-/-} mice are viable, p85-p55-p50 α ^{-/-} mice die from liver degeneration days after birth (Suzuki et al., 1999; Fruman et al., 1999). Consequently the function of p85 α gene products in lymphocytes have been studied using RAG2-deficient blastocyst complementation system, in which homozygous p85-p55-p50 α ^{-/-} ES cells were injected into RAG2^{-/-} blastocysts (Chen et al., 1993). As the RAG2-deficient mice lack mature B and T cells (Shinkai et al., 1992), any lymphocytes in such chimeras will have developed from the ES cells and therefore be deficient in all p85 gene products. Such chimeras and the intact p85 α ^{-/-} mice exhibit impaired B cell development at the pro-B cell stage, reduced numbers of peripheral mature B cells, and decreased serum immunoglobulin (Suzuki et al., 1999; Terauchi et al., 1999; Fruman et al., 1999). Most strikingly, in both kinds of mutant mice, the few B cells that do develop have diminished proliferative responses to anti-IgM, LPS, and CD40 (Suzuki et al., 1999; Fruman et al., 1999). Involvement of PI3Ks in B cell proliferation was further underscored by recent genetic deletion in mice of the gene encoding the δ isoform of the p110 catalytic subunit of PI3Ks (Jou et al., 2002). Although the mice were viable, they displayed an immuno-deficient phenotype similar to that of p85 α ^{-/-} mice, including attenuated proliferation in response to B cell mitogens (Jou et al., 2002).

The similarities between the p85 α ^{-/-} and p110 δ ^{-/-} in B cell proliferation indicate that p110 δ may uniquely associate with p85 α in the context of the BCR, given the lack of a

significant effect of p85 α and p110 δ -deficiency on TCR signalling pathways (Fruman et al., 2000; Jou et al., 2002). Furthermore, the fact that the phenotypes observed in these PI3K mutant mice resemble the defects in Xid and Btk knockout mice, suggests that PI3K and Btk are components of a common signalling pathway in calcium mobilization that can lead to cell proliferation. Apart from the calcium, however, mitogen-activated protein kinase (MAPK) is another biochemical means by which PI3K affects cell proliferation. Class I PI3Ks possess intrinsic protein kinase activity that is inseparable from their lipid kinase activity (Vanhaesebroeck et al., 1997; Stoyanova et al., 1997). The major substrates of this protein kinase activity are serine residues within the catalytic subunit itself and /or its associated regulatory subunit (Stoyanova et al., 1997). Apart from phosphorylating its own regulatory p85 subunit, and thereby decreasing the enzyme's lipid kinase activity (Carpenter et al., 1993), the protein kinase activity of PI3K was also found to be associated with the activation of MAPK. Exchange of a putative lipid substrate-binding site generated a PI3K protein with altered or aborted lipid kinase activity but retained protein kinase activity. When transiently expressed in COS7 cells, this mutant PI3K exhibited wortmannin-sensitive activation of MAPK, whereas a catalytically inactive PI3K did not, attributing MAPK activation to the protein kinase activity of PI3Ks (Bondeva et al., 1998).

In addition to reduced proliferation, decreased cell survival is another characteristic of these PI3K mutant mice (Suzuki et al., 1999; Terauchi et al., 1999; Fruman et al., 2000). The mechanism by which PI3Ks effect cell survival might be their association with the serine/threonine kinase Akt. Also known as protein kinase B (PKB), Akt is another PH-domain containing molecule that is a target of PI3K in B cells. Discovered as the cellular homolog of the v-akt oncogene, Akt was one of the first clearly identified targets of PI3K (Franke et al., 1995; Downward et al., 1998). Akt can be activated by many receptors including BCR, and in all cases the activation of Akt is dependent on PI3K (Gold et al., 2000). Therefore, the status of Akt phosphorylation is generally used as a readout of PI3K activity (Gold et al., 1999; Li et al., 1999; Jacob et al., 1999; Astoul et al., 1999).

Binding of the Akt PH domain to the PI3K-derived lipid, PIP3, recruits Akt to the plasma membrane, causes it to dimerize and induces a conformational change that allows Akt to be phosphorylated and activated by upstream kinases (Andjelkovic et al., 1997;

Datta et al., 1995). After being phosphorylated/activated at the plasma membrane, Akt translocates to the cytosol and the nucleus (Astoul et al., 1999; Meier et al., 1997).

Many substrates for Akt are critical regulators of apoptosis and cell survival, of which the first to be identified was Bad (Del Peso et al., 1997; Datta et al., 1997). Bad belongs to a distant member of the Bcl-2 family of regulators of cell death in mammalian cells (White et al., 1996). Bad promotes cell death at least in part through heterodimerization with, and therefore inhibition of, the survival proteins Bcl-2 and Bcl-x_L (Yang et al., 1995). After phosphorylation, however, Bad binds to another protein called 14-3-3, which frees the membrane-bound Bcl-x_L for anti-apoptosis effect (Zha et al., 1996). Active, but not inactive, forms of Akt were found to phosphorylate Bad both *in vivo* and *in vitro* at the same residues that are phosphorylated in response to interleukin-3(IL-3) (Del Peso et al., 1997). In growth factor promoted cell survival, Akt was also reported to phosphorylate Bad both *in vitro* and *in vivo*, and block the Bad-induced death of primary neurons in a site-specific manner, thereby suppressing apoptosis and promoting cell survival (Datta et al., 1997)

Another means by which PI3Ks can contribute to cell survival via Akt is caspase-9, an intracellular protease that functions as initiator and effector of apoptosis (Li et al., 1997). In an *in vitro* experiment, Akt phosphorylated recombinant caspase-9 on serine-196 and inhibited its protease activity, while a mutant pro-caspase-9 was resistant to Akt-mediated phosphorylation and inhibition, resulting in Akt-resistant induction of apoptosis (Cardone et al., 1998). Therefore, as for Bad, the pro-apoptotic activity of caspase-9 is also inhibited by Akt phosphorylation to promote cell survival.

Besides phosphorylating and inactivating components of the apoptotic machinery, including Bad and caspase 9 in a transcription-independent manner, Akt is also implicated in cell survival by regulating the activity of a transcription factor. In the presence of survival factor, Akt was found to phosphorylate a member of the Forkhead family of transcription factors, leading to its association with the 14-3-3 proteins in the cytoplasm, rather than its nuclear translocation to trigger apoptosis, most likely by inducing the expression of genes that are critical for cell death, such as Fas ligand gene. (Brunet et al., 1999).

1.2.4.4: The Activation of Class IA PI3Ks

Given the important role that PI3Ks play in controlling cell behaviour such as survival and proliferation, understanding the mechanisms that lead to the activation of this lipid kinase is an interesting issue. Several factors are involved in the activation of PI3Ks in B cells following BCR engagement.

Y-x-x-M-Containing Scaffolding proteins

PI3K is a cytosolic enzyme and receptor-induced production of PIP3 in the plasma membrane reflect translocation of PI3K from the cytosol to the membrane. The two SH2 domains of the PI3K p85 regulatory subunit are utilized to recruit the p110 catalytic subunit to the membrane by binding to phosphotyrosines present in receptor tails or other membrane-associated signalling molecules. Indeed the motif Y-x-x-M (x denotes any amino acid) has been shown to have strong binding affinity to the two SH2 domains of p85 (Okada et al., 2000). However, unlike growth factor receptors that undergo ligand-induced autophosphorylation on the Y-x-x-M motif and directly recruit PI3K, the Ig α / β subunits of the BCR do not contain Y-x-x-M sequences. Therefore, the ability of the BCR to recruit PI3K to the plasma membrane depends on its ability to induce the phosphorylation of Y-x-x-M motifs on other membrane-associated docking proteins. CD19 is a B cell co-receptor that has two Y-x-x-M motifs in its cytoplasmic tail. The tyrosine in the Y-x-x-M motifs is rapidly phosphorylated after BCR ligation (Tuveson et al., 1993), recruiting PI3K to the plasma membrane. Changing tyrosines 484 and 515 in the motifs to phenylalanine residues was reported to abrogate the ability of CD19 to bind PI3K, which severely impaired BCR-induced activation of PI3K (Buhl et al., 1997). This result suggests that CD19 is the major membrane docking site for PI3K in BCR-stimulated B cells. However, recently another group reported that in the B cells of CD19 knockout mice, BCR induced PI3K activity is comparable to that of wild type counterpart if not higher (Fujimoto et al., 2002), suggesting a compensational role of other Y-x-x-M sequence-containing docking molecules in B cells in the absence of CD19.

One such docking protein that BCR uses to mobilize PI3K in B cells is B cell adaptor for PI3Ks (BCAP). BCAP possesses four Y-x-x-M motifs and associates with p85 proteins following BCR stimulation of chicken or mouse B cells. Deletion of BCAP in chicken DT40 cells reduces BCR-triggered PIP3 production, leading to impaired Akt response, though not as completely as wortmannin treatment (Okada et al., 2000). Transfection experiments demonstrated that phosphorylation of the Y-x-x-M motifs in BCAP is critical for PI3K activation (Okada et al., 2000). Later on, the Y-x-x-M motifs in BCAP were shown to be even more important than that of CD19 in CD19-mediated PI3K signalling pathway (Inabe et al., 2002), laying a solid foundation for BCAP in PI3K activation. These cell line-derived results, however, need to be confirmed in the animal to address the physiological association of BCAP with PI3K. Mutant mice deficient in BCAP were recently generated, and showed decreased numbers of mature B cells, a B1 B cell deficiency, lower titers of serum IgM and IgG3, and an attenuated responses to T cell-independent type II antigens (Yamazaki et al., 2002), a phenotype resemble that of Btk-deficient mouse line (Khan et al., 1995) and XID mice (Tsukada et al., 1993; Rawlings et al., 1993), to which, mice deficient in p85 α regulatory subunit of PI3K also bear similarity (Suzuki et al., 1999). Therefore, it is likely that BCAP and PI3K work through each other *in vivo*. Biochemically, although BCR-induced calcium mobilization and proliferative response were reduced, the kinase activity of Akt and PI3K in the BCAP-deficient B cells, however, were comparable to that of the wild type control (Yamazaki et al., 2002), indicating either a downstream identity of BCAP in PI3K pathway or a redundancy between the adaptor proteins for PI3K activation.

Gab1 is a member of a family of docking proteins, which include p120 Gab1 and p97 Gab2 (Holgado-Madruga et al., 1997; Gu et al., 1998). Although Gab1 and Gab2 are encoded by different genes, they both contain conserved PH domains as well as the potential SH2 domain-binding sites. While Gab2 appears to play a role in PI3K activation downstream of various cytokine receptors (Gu et al., 2001), Gab1 is tyrosine phosphorylated following BCR stimulation and interacts with class IA PI3K (Ingham et al., 1998). Over-expression of Gab1 in the WEHI-231 B cell line cause Gab1 to potentiate BCR-induced tyrosine phosphorylation of Akt, and Gab1 PH domain as well as PI3K activity were required for the BCR-induced translocation of Gab1 from the cytosol to the plasma membrane (Ingham et al., 2001). These results suggest that Gab1

may be both upstream and downstream of PI3K and respond to the PI3K signal by amplifying or extending the duration of PI3K activation.

Protein Tyrosine Kinases

Recruitment of PI3K to the plasma membrane by these docking proteins serves to bring it in proximity to its membrane substrates, notably PI(3,4)P₂, for maximal enzyme activity. But the most important advantage for this cytosolic enzyme to be present in the membrane is that some membrane-rich PTKs might activate it easily. The tyrosine kinases involved in BCR-induced activation of PI3K have been examined in great detail in cell lines by loss-of-function approaches, using the activation of Akt as a readout. Since PI3K is rapidly activated after BCR cross-linking, and Src-family PTKs and Syk are thought to be the initiators of signalling events downstream of the BCR, the role of these PTKs in PI3K activation were checked first. In DT40 B cell line expressing Lyn but not Syk, BCR-induced Akt phosphorylation occurred, but the level was lower than that of wild-type controls (Gold et al., 1999; Li et al., 1999). Additionally, the BCR-induced Akt phosphorylation was also quite transient in the absence of Syk, as opposed to the sustained BCR-induced Akt phosphorylation observed in the wild-type DT40 B cells. When both Lyn and Syk were deleted in the DT40 B cells, BCR-induced Akt phosphorylation was completely ablated (Gold et al., 1999), indicating a requirement for both Src and Syk PTK for PI3K activity. Furthermore, the effect of Syk on accumulation of PIP₃, the product of PI3K, in B cell signalling was tested by dominant negative and gene knockout approaches. Both methods indicated that Syk is upstream of, and necessary for, a significant portion of BCR-induced PIP₃ production (Beitz et al., 1999). These results indicate that while Src family tyrosine kinases can mediate activation of the PI3K/Akt pathway, the Syk tyrosine kinase is required for maximal and sustained activation of this signalling pathway.

The mechanisms involving the activation of PI3K by Syk may be associated with its ability to tyrosine phosphorylate the adaptor molecules for PI3K, such as BCAP. Indeed, the phosphorylation of BCAP is reported to be reduced in Syk-deficient B cell lines (Okada et al., 2000). Unlike Syk, the mechanisms of Src family PTKs in activating PI3Ks may involve the direct interaction between these two kinase families. Early in

1992, a group of Japanese scientist reported that PI3K bound Lyn tyrosine kinase in a BCR-induced manner (Yamanashi et al., 1992), indicating a physical association, albeit weak, between Src-PTKs with PI3Ks. Later on, the *in vitro* binding assay of Lyn (Pleiman et al., 1994), Fyn (Prasad et al., 1993; Kapeller et al., 1994; Pleiman et al., 1994) and Lck (Kapeller et al., 1994) to PI3Ks demonstrated that this interaction occurred between the SH3 domains of Src-PTKs and proline-rich motifs of p85 α , the regulatory subunit of PI3Ks, which enhances the activity of the associated PI3K catalytic subunit (Pleiman et al., 1994).

While Src-PTKs and Syk were demonstrated to promote Akt/PI3K activation, Lyn, a member of Src-PTK family, however, was found to have an opposite role. BCR cross-linking of Lyn-deficient B cells resulted in markedly enhanced phosphorylation and activation of Akt in both cell lines and splenic B cells, compared with wild-type controls (Li et al., 1999; Craxton et al., 1999). Furthermore, the negative regulation of Akt in DT 40 B cells by Lyn was shown not to depend on the protein phosphatase SHP-1, SHP-2, or SHIP (Li et al., 1999), indicating the existence of an alternative pathway, by which, Lyn negatively regulates PI3K signals downstream of the BCR complex.

Ras

Apart from the protein tyrosine kinase and tyrosine phosphorylated scaffold proteins, receptor-mediated activation of PI3K was also reported to be associated with the direct binding by Ras. *In vivo*, a dominant negative Ras mutant inhibited growth factor induced production of 3' phosphorylated phosphoinositides in PC12 cells and transfection of Ras, but not Raf, into COS cells resulted in a large elevation in the level of these lipids (Rodriguez-Viciana et al., 1994). *In vitro*, the interaction of Ras-GTP, the active form of Ras, but not Ras-GDP, with PI3K led to an increase in its enzymatic activity in fibroblasts following growth factor stimulation and this stimulation was synergistic with the effect of tyrosine phosphopeptide binding to p85 (Rodriguez-Viciana et al., 1996). Besides, evidence from experiments using platelet-derived growth factor (PDGF)-receptor mutants also suggested that accumulation of GTP-bound Ras was required for full activation of class IA PI3K (Klinghoffer et al., 1996). Finally, the dependence of PI3K activation on Ras interaction was also examined in IgG-bearing

A20 murine B cell line, using activation Akt as an indirect measurement for PI3K activity. After transient transfection with HA-tagged Akt cDNA, in combination with a dominant negative mutant of Ras, both basal and BCR-stimulated HA-Akt activity was completely inhibited, compared with 3-5 fold increase of BCR-induced HA-Akt activity in cells transfected with empty vector, indicating that the activation of PI3K and its effector Akt by BCR is downstream of Ras (Jacob et al., 2002).

Taken together, these data indicate that PI3Ks might be another class of Ras effector molecules, alongside proteins such as the Raf Ser/Thr kinases. The interaction of Ras with PI3K might result in allosteric activation and/or contribute to PI3K recruitment to the plasma membrane. However, it should be noted that some data also position Ras downstream of PI3Ks, which will be discussed in the following section. Therefore, PI3K can be regulated by a number of mechanisms, and Ras contributes to the activation of this lipid kinase synergistically with tyrosine kinases.

1.3: SIGNALLING PATHWAYS INITIATED FROM THE B CELL RECEPTOR:

The protein tyrosine kinases and lipid kinases activated by BCR-stimulation act to trigger a complex panel of early signalling events. Of these, three important signalling pathways convey the BCR signals to nucleus: These are PLC- γ 2 pathway; Ras pathway; and PI3K pathway.

1.3.1: PLC- γ 2 Pathway:

The first signalling pathway to be activated following BCR engagement was the PLC- γ 2 pathway. PLC- γ is a phospholipase which hydrolyzes phosphatidylinositol 4,5-bisphosphate (PI4,5-P₂) to form diacylglycerol (DAG) and inositol 1,4,5-trisphosphate (IP₃) (Bijsterbosch et al., 1985). Two PLC- γ isoforms are expressed in B cells: PLC- γ 1 and PLC- γ 2. Unlike most other cell types, in which PLC- γ 1 predominates, B cells contain PLC- γ 2 as the main isoform (Marshall et al., 2000). Although both isoforms appear to participate in BCR signal transduction (Carter et al., 1991; Hempel et al., 1992), it is not clear whether they play distinct functional roles. Activation of PLC- γ

upon BCR ligation requires both its recruitment to the membrane and its tyrosine phosphorylation. PLC- γ has several protein-protein interaction domains in its structure, such as PH, SH2 and SH3 domains, which can be utilized to associate with scaffolding proteins for recruitment to the vicinity of the membrane. Among these domains, SH2 is known to play a critical role in PLC- γ activation (Takata et al., 1995). The ligand for the SH2 domains of PLC- γ , however, was unknown until a tyrosine-phosphorylated adaptor protein, termed B cell linker protein (BLNK) was identified (Fu and Chan, 1997; Goitsuka et al., 1998; Wienands et al., 1998). The 65kDa BLNK protein was rapidly tyrosine phosphorylated after BCR cross-linking and then was found to be dependent on Syk, rather than Lyn or Btk (Fu et al., 1998). Over-expression of wild-type BLNK promoted BCR-induced calcium mobilisation, while disruption of BLNK in DT40 B cells abrogated PLC- γ phosphorylation and calcium response upon BCR ligation (Ishiai et al., 1999). The binding of PLC- γ SH2 domain to the phosphotyrosines in BLNK brings PLC- γ into close proximity with the BCR signalling complex, whereby PLC- γ becomes tyrosine phosphorylated and activated (Ishiai et al., 1999; DeBell et al., 1999).

Syk- but not Lyn-deficient DT-40 cells exhibited an almost complete loss of tyrosine phosphorylation of PLC- γ 2 and IP3 generation (Takata et al., 1994), suggesting that Syk plays an indispensable role in PLC- γ phosphorylation and activation. When Btk was disrupted in DT 40 cells, however, the phosphorylation of PLC- γ 2 was slightly reduced, but IP3 generation was almost complete lost (Takata et al., 1996), indicating that both Btk and Syk are required for PLC- γ activation, but they may be involved in phosphorylating different tyrosines on PLC- γ .

Since Syk activation precedes that of Btk following BCR ligation (Saouaf et al., 1995), a model of PLC- γ activation has been proposed in which the initial /partial activation of PLC- γ is dependent mainly on Syk but its later /full activation requires both Syk and Btk (Rawlings et al., 1999). After BCR cross-linking, Syk becomes activated and thereby phosphorylates BLNK, creating binding sites for PLC- γ via its SH2 domain. This would bring PLC- γ into proximity with Syk, leading to its phosphorylation and partial activation by Syk. In the later stage of BCR cross-linking, Btk is recruited to the membrane by binding via its PH domain to the PIP3, the product of PI3K (Varnai et al., 1999). Besides, BLNK has also been reported to associate with membrane recruited Btk

in that Btk binds via its SH2 domain to the phosphorylated BLNK (Su et al., 1999; Hashimoto et al., 1999). After recruitment to the plasma membrane, Btk is phosphorylated and activated probably by Src-PTKs (Rawlings et al., 1996). Activated Btk then phosphorylates PLC- γ , resulting in the full activation of PLC- γ .

After being activated by the above mechanism, PLC- γ generated DAG and IP3 act as second messengers in signal transduction. DAG is a lipophilic compound that remains in the plasma membrane and activates most protein kinase C isozymes (Sidorenko et al., 1996; Barbazuk et al., 1999; Bras et al., 1997), which can also be activated by the tumor-promoting phorbol esters (phorbol myristate acetate, PMA, etc.). The functions of the different isoforms of PKCs vary. While PKC β was reported to associate with and phosphorylate Btk (Yao et al., 1994), PKC μ may be a negative regulator of BCR signalling as it can phosphorylate Syk *in vitro* and inhibit its ability to phosphorylate PLC γ 1 (Sidorenko et al., 1996). Although discrepancies exist among the functions assigned to the PKCs and the function of some of them remains unclear, stimulation of B cells with phorbol esters, the activator of PKCs, activates the p42/p44 form of mitogen-activated protein kinases (Erk) (Gold et al., 1992) and synergizes with the calcium signal (see following section for details) to activate the transcription factors NFAT (nuclear factor of activated T cell) and NF- κ B (Venkataraman et al., 1994; Baeuerle et al., 1994). The transcription factor CREB (cAMP response element binding protein) is also activated upon stimulation of protein kinase C with phorbol esters in B cells (Xie et al., 1995; Xie et al., 1996), suggesting that it is another direct or indirect target of PKC.

The other second messenger released by PLC- γ is IP3, which is water soluble and diffuses to the endoplasmic reticulum where it interacts with the IP3 receptor that causes the release of calcium ions from this intracellular compartment. Full release of the intracellular calcium stores results in the opening of the plasma membrane calcium channels that are responsible for the entry of extracellular calcium that produces the sustained elevation of calcium. Therefore, IP3 stimulates both calcium release intracellularly and calcium entry extracellularly, with the former triggering such events as muscle contraction, secretion, adhesion and synaptic transmission, and the latter inducing cell proliferation and differentiation (Parekh et al., 1997; Putney et al., 1993). The amplitude and duration of calcium signals in B cells controls differential activation of the

pro-inflammatory transcriptional regulators NF- κ B, c-Jun N-terminal kinase (JNK) and NFAT. NF- κ B and JNK are selectively activated by a large transient calcium

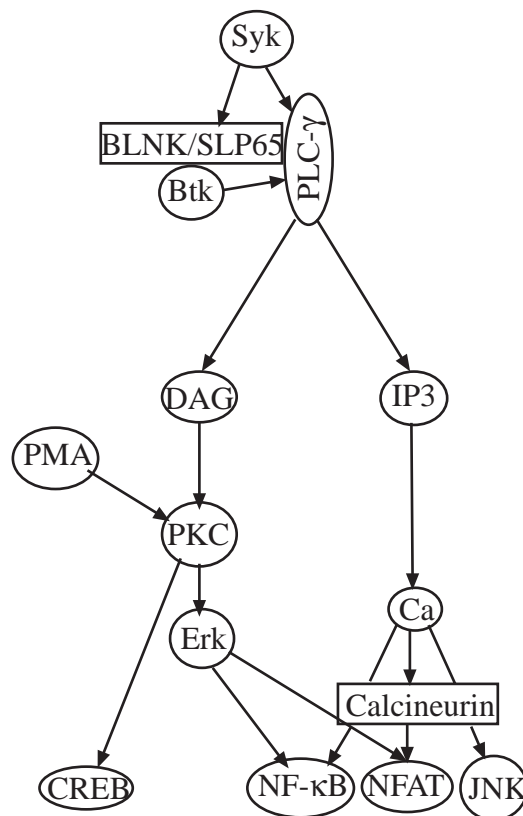

Figure 1.6: PLC- γ pathway: After BCR cross-linking, PLC- γ is first partially activated by Syk and then fully activated by both Syk and Btk mediated via phosphorylated BLNK, a target of Syk activity. Activated PLC- γ generates DAG and IP3 as second messengers, with the former activating Erk through PKC, and the latter opening calcium channels inside the cell. Once activated, Erk synergizes with the calcium signals to activate several transcription factors including CREB, NFAT, and NF κ B.

rise whereas NFAT is activated by a low, sustained calcium plateau (Baeuerle et al., 1994; Dolmetsch et al., 1997). Although initially described as a transcription factor that is important for cytokine gene expression in TCR- stimulated T cells, NFAT is clearly can be activated by BCR stimulation in B cells (Venkataraman et al., 1994). The activation of NFAT is caused by its dephosphorylation by calcineurin, the calcium activated serine/threonine phosphatase (Clipstone et al., 1992; Jain et al., 1993). Dephosphorylation of NFAT leads to its nuclear translocation and participation in calcium-dependent induction of genes required for lymphocyte activation and proliferation (Timmerman et al., 1996).

1.3.2. Ras Pathway

The second major signalling pathway triggered in response to BCR engagement is the Ras pathway. Ras is an important regulator of cell growth and differentiation in most cell types (McCormick et al., 1994). The activity of Ras is determined by the nature of a bound guanine nucleotide in such a way that GDP binding makes Ras inactive and GTP binding makes Ras active (De Vendittis et al., 1986; Hattori et al., 1986). The binding state of Ras, however, is controlled by nucleotide exchange factors (e.g. mSOS1 and mSOS2), which are translocated to the plasma membrane where Ras is located upon receptor engagement. The membrane recruitment of mSOSs are associated with the adapter protein Shc, which is tyrosine phosphorylated after BCR stimulation and assembles with another adapter protein, Grb2, in complexes (Lankester et al., 1994; Saxton et al., 1994; Smit et al., 1994).

After being recruited to the plasma membrane and in close proximity to Ras, the mSOSs exchange factors promote the release of GDP from Ras (inactive state) for GTP binding (active state). The conversion of Ras from an inactive to an active state, however, is negatively regulated by other molecules, called GTPase activating proteins (GAPs) that hydrolyze the bound GTP to yield GDP and phosphate (McCormick et al., 1994; McCormick et al., 1996). BCR stimulation results in tyrosine phosphorylation of both

RasGAP, and two RasGAP-associate proteins of 190kDa and 62 kDa (Gold et al., 1993). The cloning of the genes encoding these proteins showed that the p190 protein is a GAP for the Rho family members, which may allow the coupling of signalling pathways that involve Ras and Rho GTPases (Settleman et al., 1992). The p62 RasGAP –associated protein, which appeared to be a docking protein based on its structure and the fact that it was rapidly tyrosine phosphorylated after receptor cross-linking, was termed p62^{dok} (Carpino et al., 1997; Yamanashi., 1997). The negative role of p62^{dok} in the Ras pathway was unknown until 1999 when it was found to be a substrate of the Src-family Lyn by an *in vitro* phosphorylation-screening strategy (Lock et al., 1999), and later on, the phosphorylation of Erk was found to be enhanced in the p62^{dok} deficient mice (Yamanashi et al., 2000).

Activated Ras then interacts with and activates the serine/threonine protein kinase Raf by recruiting Raf to the plasma membrane where a separate, Ras-independent, activation of Raf occurs (Stokoe et al., 1994). Once activated, Raf serine phosphorylates two further MAP kinase kinases (MEK1/2), the dual specificity kinases that in turn phosphorylate two key regulatory threonine and tyrosine residues in extracellular-signal regulated kinase (Erk) 1 and Erk 2 (Crews et al., 1992; Dent et al., 1992; Kyriakis et al., 1992). These MAP kinases are clearly activated in B cells stimulated through the BCR. Of the two isoforms of pp44/pp42 (Erk1/2), only p42-kDa Erk (Erk2) appears to be activated and tyrosine-phosphorylated to a significant extent upon BCR engagement (Sutherland et al., 1996). Although protein kinase C (PKC) is involved in the activation of the Erks in B cells, the sIg-stimulated Erk activation and tyrosine phosphorylation were only partially blocked by a PKC inhibitor, indicating the existence of both PKC-dependent and –independent Erk activation mechanisms by BCR (Casillas et al., 1991; Gold et al., 1992; Tordai et al., 1994).

Upon activation, the Erks either phosphorylate a number of cytoplasmic targets or migrate to the nucleus. The translocation of Erks to nucleus is rapid (seen in 15 min), persistent (at least during the entire G1 period up to 6 hours), reversible (by removal of the mitogenic stimulus) and apparently coupled to the mitogenic potential of the serum (Lenormand et al., 1993). In the nucleus, the Erks phosphorylate and activate a number of transcription factors including the Ets-family members that cooperate with Serum Response Factor (SRF) to activate transcription at Serum Response Elements (SREs)

(Treisman et al., 1996). Among the early response genes of BCR-stimulated B cells known to be regulated by SREs are *c-fos* and *egr-1* (DeFranco et al., 1993), which encode proteins responsible for important cell behaviour (Maltzman et al., 1996a;

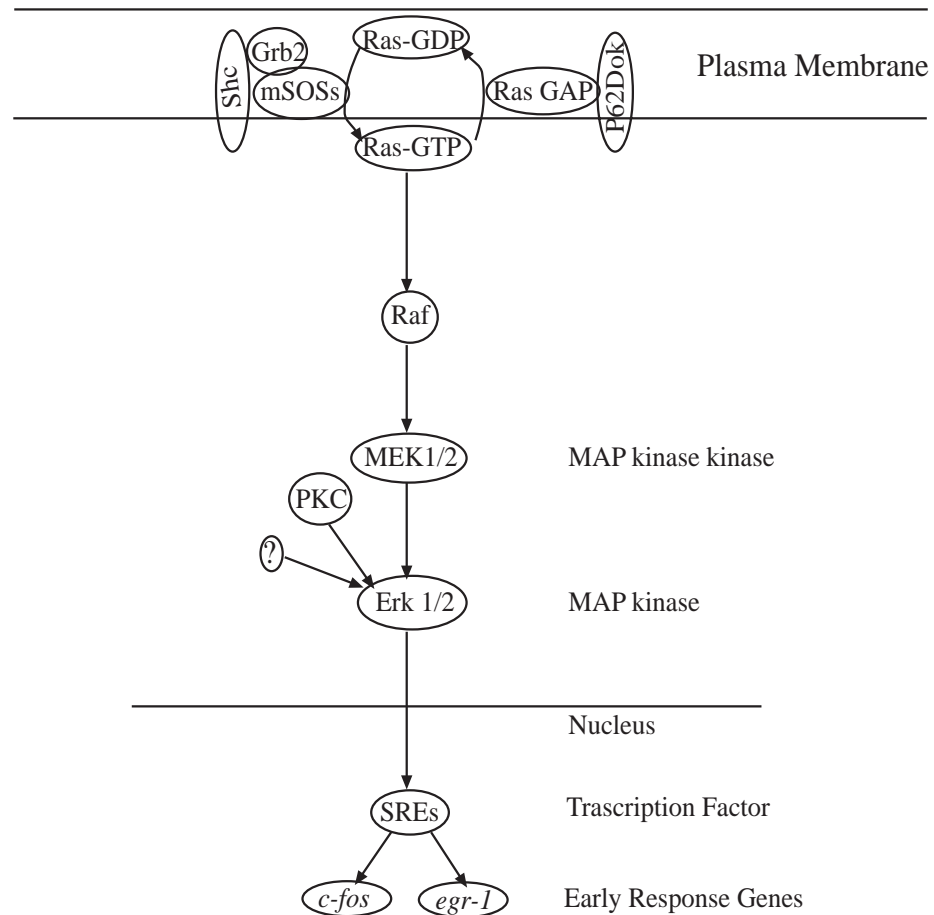

Figure 1.7: Ras pathway: Membrane localized Ras is converted between active (GTP binding) and inactive (GDP binding) forms by signalling complexes of Grb2/mSOSs and Ras GAP, which are recruited to the plasma membrane by the phosphorylated adaptor molecules Shc and p62^{dok} respectively. Ras-GTP recruits and activates Raf, which activates the MAP kinase kinase MEK1/2 and finally leads to the activation of the MAP

kinases Erk1/2. Once activated, Erk1/2 translocates into the nucleus and activates the transcription factor SRE to start the transcription of early response genes.

Maltzman et al., 1996b). Abnormal activation of the Erk pathways can result in the growth and pathological behaviour of cancer cells (Walter et al., 2000). The Ras/Erk pathway has long been known to be important in many cell types for receptor-induced proliferation responses (Pages et al., 1992; Woods et al., 1997). The effects of Erks in BCR-induced proliferation, however, were not fully addressed until recently when Richards *et al* used two structurally and mechanistically distinct inhibitors to investigate the role of this pathway in B cell behaviour. These inhibitors suppressed BCR-induced activation of Erk MAP kinase only but not other forms of MAP kinase such as JNK in all B cell types tested (Richards et al., 2001). Although the BCR-induced cell cycle arrest or apoptosis in WEHI-231 cells and primary immature splenic B cells was undisturbed by these inhibitors, both inhibitors blocked BCR-induced proliferation of mature splenic B cells, as well as the induction of the proteins involved in cell-cell interactions and B cell trafficking such as CD44 adhesion protein and CD69 activation marker. These results indicate a critical role for Erk in BCR-induced proliferation. In agreement with this findings, the enhanced BCR-induced Erk activity observed in Lyn knockout mice (Chan et al., 1997) correlates with enhanced B cell proliferation despite most of the BCR-induced immediate signalling events being delayed or decreased to some extent (Hibbs et al., 1995; Wang et al., 1996; Nishizumi et al., 1998).

1.3.3. Phosphatidylinositol 3-Kinase Pathway

A third signalling pathway initiated by BCR cross-linking is the phosphatidylinositol 3-kinase (PI3K) pathway. BCR stimulation leads to rapid activation of PI3Ks and accumulation of its product PIP3 in the plasma membrane, which in turn attracts PH domain-containing molecules from the cytosol to be activated, as summarized in previous sections. There are two major PH domain-containing targets of PIP3 in the PI3K signalling pathway: the serine/threonine protein kinase Akt/PKB and the Tec family non-receptor kinase Btk. Since the role of Akt/PKB in inhibiting apoptosis and of

Btk in calcium flux have been reviewed in detail, only the emerging effect of PI3K pathway on p44/p42 MAPK (Erk1/2) activation will be discussed here.

The relevance of PI3K for activation of Erk was observed in several experimental systems. First expression of activated forms of p110 α PI3K was reported to stimulate diverse Ras/MAP kinase -dependent cellular processes including oocyte maturation and *fos* transcription (Hu et al., 1995). Second, over-expression of PI3K γ in COS-7 cells activated MAP kinase in a G-protein-dependent fashion, while expression of a catalytically inactive mutant of PI3K γ abolished the stimulation of MAPK (Lopez-Illasaca et al., 1997).

In addition to genetic manipulation, pharmaceutical approaches have been explored to confirm the effect of PI3K on MAP kinase activation. Inhibition of PI3K with wortmannin has been shown to block activation of MAP kinase in several cell types (Hu et al., 1996; Duckworth et al., 1997; Wennstrom et al., 1999; Pirola et al., 2001). Wortmannin blocked platelet-derived growth factor (PDGF)-dependent activation of Raf-1 and the MAP kinase cascade in Chinese hamster ovary cells, which have few PDGF receptors, but had no significant effect on Erk activation in Swiss 3T3 cells, which have high levels of PDGF receptors (Sturani et al., 1986). However, wortmannin could block activation of Erk proteins if Swiss 3T3 cells were stimulated with lower, physiological levels of PDGF (Duckworth et al., 1997). These results suggest that PI3K is in an efficient pathway for activation of MAP kinase, but MAP kinase can also be stimulated by a redundant pathway when a large number of receptors are activated.

Treatment of T cells with wortmannin blocked anti-CD3-induced activation of the MAP kinase Erk2 while wortmannin had no effect on the activity of Erk2 when added directly to the in vitro assays. In addition, expression of a disruptive PI3K construct also reduced Erk2 activation, while a construct that stimulates PI3K enhanced the activation of Erk2 (Von Willebrand et al., 1996). Receptor-induced activation of other Ser/Thr kinases such as c-Raf, B-Raf, Mek1, Mek2, Mekk, was not affected by wortmannin (Von Willebrand et al., 1996).

The cross-talk between PI3 Kinase and Erk MAP kinase in B cells has not been fully investigated until recently when different PI3K inhibitors and dominant-negative PI3K constructs were used to inhibit PI3 kinase activity following BCR stimulation. In each

case the BCR-induced Erk phosphorylation/activation was blocked. This influence of PI3K on Erk activation was independent of intracellular calcium mobilization because reconstitution of calcium flux by the calcium ionophore ionomycin in the absence of PI3K activity failed to restore Erk phosphorylation (Jacob et al., 2002). Further experiments showed that PI3K influences the Ras cascade both up-stream and downstream of Ras itself, suggesting that PI3K and Ras pathways in B cells are intimately connected at several levels (Jacob et al., 2002).

While accumulating data demonstrate the requirement of PI3K for Erk MAP kinase activation, the intermediate targets that link PI3K to Erk MAP kinase, however, remain elusive. Phospholipase C family members could be such intermediaries. Indeed, PLC- γ is a downstream target of PI3K, because PLC- γ itself is also a PH domain-containing molecule (Falasca et al., 1998; Bae et al., 1998). The PH domain of PLC- γ binds to the PI3K product, PIP3, and is thus targeted to the membrane to be activated. Consistent with this, activation of PI3K caused PLC- γ PH domain-mediated membrane targeting and PLC- γ activation in response to growth factor stimulation (Falasca et al., 1998). In addition, PIP3 was reported to activate purified PLC- γ isozymes *in vitro* (Bae et al., 1998) and expression of an activated catalytic subunit of PI3K in COS-7 cells resulted in an increase in inositol phosphate formation, suggesting an alternative mechanisms of PLC- γ activation independent of its phosphorylation (Bae et al., 1998). These results demonstrate that PI3K can affect PLC- γ activity not only indirectly via Btk, but directly via PIP3 as well. After full activation, this phospholipase generates the second messenger DAG to activate PKC. PKC is upstream of Erk, because stimulation of PKC with phorbol esters was reported to activate Erk MAP kinase (Gold et al., 1992), as has been summarized in the PLC- γ pathway (Section 1.3.1).

There are also reports indicating an alternative pathway by which PI3K can have an affect on Erk activation. In B cell lines, PI3K activity was found to be required for the activation of Ras and MEK, the upstream activator of Erk, although assembly of the Shc/Grb2/Sos complex was unaffected by PI3K inhibition (Jacob et al., 2002), suggesting that PI3K can influence Erk activation via the Ras pathway. Furthermore, transient expression of a trimeric G-protein-sensitive phosphoinositide 3-kinase (PI3K γ) (Stoyanov et al., 1995) hybrids, in which a putative lipid substrate-binding site was exchanged to abort lipid kinase activity but retain protein kinase activity, exhibited

wortmannin-sensitive activation of MAP kinase in COS cells, whereas a catalytically inactive PI3K γ did not (Bondeva et al., 1998). Membrane-targeted PI3K γ constitutively produced PIP3 and activated Akt but not MAP kinase (Bondeva et al., 1998), indicating the protein kinase activity of PI3K can lead to Erk activation independent of lipid kinase

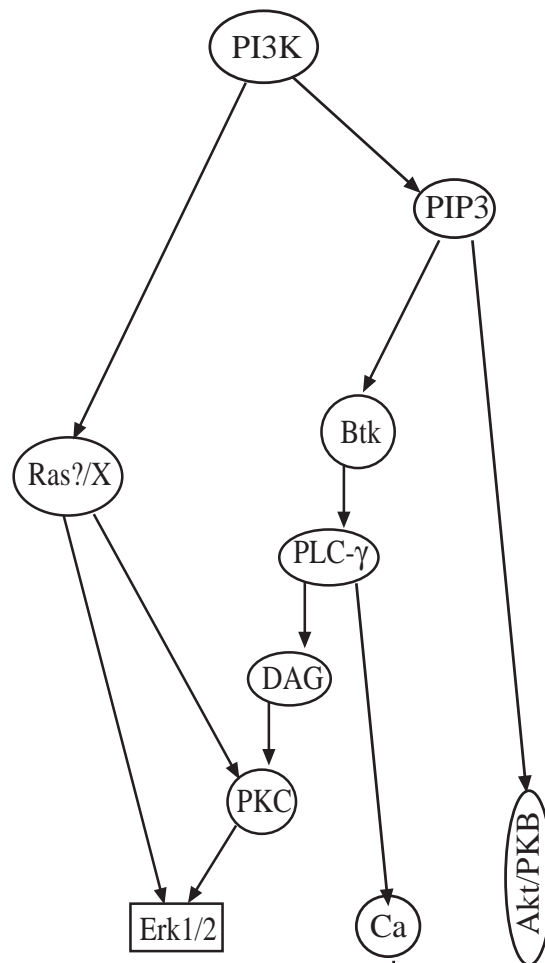

Figure 1.8: PI3K pathway: The PI3K generated lipid product PIP3 acts to recruit and activate PH domain-containing molecules such as Akt and Btk, which promote cell

survival and full activation of the PLC- γ pathway respectively. PI3K might also have an input in the activation of the Ras pathway as well, indicated as Ras ?/X.

activity. Consistent with this idea, a separate group also reported the protein kinase activity of PI3K activates Erk but not Akt in 293 cells (Pirola et al., 2001), further demonstrating the possibility of multiple ways from PI3K towards Erk activation.

1.4: REGULATION OF BCR SIGNALLING:

Since the signal initiated from BCR can generate the diverse biochemical pathways as discussed above that combine to induce such different biological responses as proliferation, differentiation and apoptosis, depending on the context of the BCR signals, it must be properly regulated. Unbalanced signalling from BCR may cause detrimental effects such as autoimmunity or immunodeficiency. B cells, however, overcome these potential problems by utilizing several regulatory molecules to control signal strength via adjusting the threshold for the B cell receptor. Of the numerous regulatory molecules employed by the BCR, two are of particular importance: One is the BCR co-receptor CD19 and the other is Src family protein tyrosine kinase Lyn.

1.4.1: Positive Regulation of BCR Signalling by CD19:

CD19 is an approximately 95kDa glycoprotein member of the immunoglobulin super-family expressed exclusively on B cells (Sato et al., 1996). In mouse, this surface protein is expressed from the early pre-B cell stage until the time of plasma cell differentiation. Mature conventional B cells (B-2) from different peripheral lymphoid tissues have similar CD19 expression levels that are lower than those of CD5⁺ (B-1) B cells (Krop et al., 1996).

1.4.1.1: Structure of CD19:

The extracellular domain of CD19 contains two C2-type Ig-like domains separated by a smaller, potentially disulfide-linked domain. On the surface of mature B cells, CD19 forms a heterologous non-covalent complex with CD21, a receptor for complement

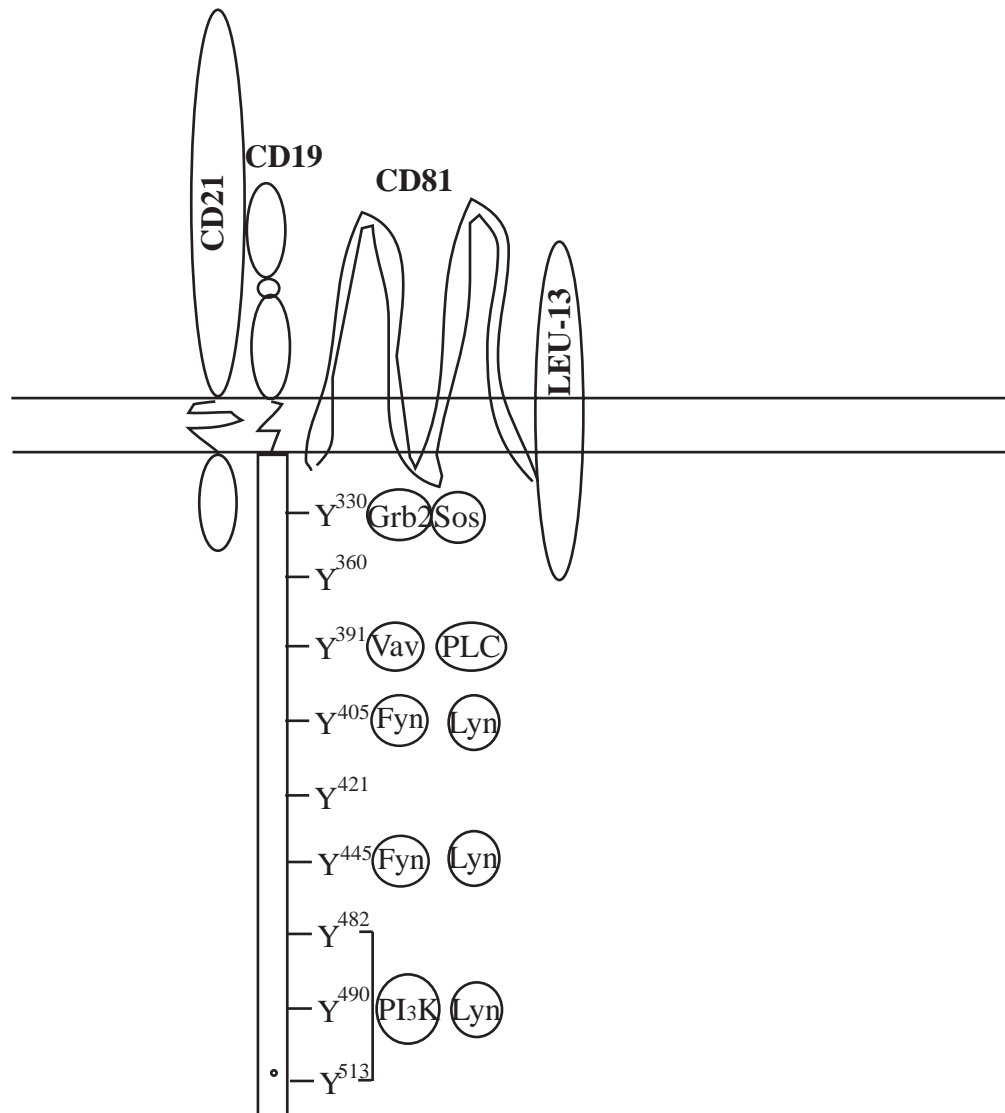

Figure 1.9: Model of CD19 structure: CD19 forms a complex with CD21, CD81 and Leu-13 on the cell surface. The cytoplasmic domains of CD19 contain 9 tyrosines

designated as Y with corresponding amino acid positions labelled. After phosphorylation of these tyrosines, they bind to potential signalling molecules as indicated to amplify signal transduction.

cleavage fragments generated during complement activation (Carroll et al., 1998). In addition, CD19 interacts with CD81, a broadly expressed member of the tetraspanin family of cell-surface molecules that are involved in multiple, diverse signalling pathways (Bradbury et al., 1992; Maecker et al., 1997). CD81 associates with another widely expressed cell-surface molecule termed Leu-13 (Deblandre et al., 1995; Matsumoto et al., 1993). Although the functional significance of this multi-molecular complex on the cell surface is not understood, it was envisioned that CD19 and its associated CD81/Leu-13 molecules provide a signalling function to inform B cells of complement activation in their microenvironment (Tedder et al., 1999).

Intracellular signalling arising from the CD19/CD21/CD81 complex is, however, independent of both CD21 and CD81 (Matsumoto et al., 1993), but requires the cytoplasmic domain of CD19, because the phenotypes of transgenic mice that expressed only the extracellular and transmembrane domains of CD19 were similar, if not identical, to CD19-deficient mice (Sato et al., 1997). The cytoplasmic domain of CD19 is approximately 240 amino acid long and contains 19% acidic and 9.5% basic amino acid residues, with some localized regions of strong net negative charge (Teffer et al., 1994). There are nine tyrosines in the cytoplasmic tail of CD19, which are highly conserved among human, mouse and guinea pig (Zhou et al., 1991), indicating the importance of this domain for CD19 function. Of the nine tyrosine residues, three have been formally shown by mutational analysis to be phosphorylated: tyrosines-391, -482 and -513 (Li et al., 1997; O'Rourke et al., 1998; Tuveson et al., 1993). The former binds Vav and PLC- γ 2 through its SH2 domain (Weng et al., 1994; Li et al., 1997; O'Rourke et al., 1998; Brooks et al., 2000), and the latter two cooperate to bind PI3K through the SH2 domains of this enzyme's p85 subunit (Tuveson et al., 1993). The tyrosine-482 and -513 were recently found to be important for most of CD19 functions *in vivo* (Wang et al., 2002). Phosphotyrosyl peptides with sequences corresponding to Y405 and Y445 of CD19 and having the sequence, YEND/E, have been shown to bind a fusion protein containing the SH2 domain of Fyn (Chalupny et al., 1995), although mutation of this site has not been

done to determine its role in signalling by CD19. Phosphopeptides matching CD19 Y330 precipitated a complex that included Grb2 and Sos, which were also detected in CD19 immunoprecipitates from activated cells (Brooks et al., 2000; Fujimoto et al., 2000).

1.4.1.2: The Function of CD19

CD19 is required for normal B cell responses in mice and is likely to play a regulatory, and perhaps pathogenic role in human autoimmune disease such as SLE (Kuroki et al., 2002). Gene disruption studies in mice showed that the peritoneal B 1 and the splenic marginal zone B cell subsets are fully dependent on CD19 (Engel et al., 1995; Martin and Kearney, 2000; Rickert et al., 1995; Sato et al., 1995). The IgG response to antigens is dramatically reduced in these animals, with a commensurate reduction in number and size of germinal centres (Fearon and Carroll, 2000). Conversely, transgenic mice that over-express CD19 by threefold on B cells have a reciprocal phenotype (Zhou et al., 1994). A hallmark of these mice is an increased B-1 cell population in the peritoneal cavity (Sato et al., 1996). Surface IgM levels are reduced on B cells from these mice, but their B cells are hyper-responsive to transmembrane signals and proliferate at elevated levels (Sato et al., 2000). The over-expression of CD19 also resulted in the development of autoimmune disease in the transgenic mice (Tedder et al., 1997). The immune-deficiency associated with the loss of CD19 and the autoimmune tendency associated with too much CD19 strongly suggest a positive regulatory role of this surface co-receptor in promoting BCR signalling.

The positive role of CD19 *in vivo* can be explained by the following *in vitro* experiments as well as the mechanisms based on these *in vitro* observations:

Calcium Mobilization:

Since intracellular calcium flux is an important index for cell response, the role of CD19, as a signalling molecule in calcium flux was first examined by cross-linking it alone with monoclonal antibodies and an elevated intracellular calcium was found (Pezzutto et al., 1987), generating the first link between CD19 and calcium response. Later on, co-ligation of CD19 with surface Ig synergistically increased intracellular calcium levels, in

that the response achieved by simultaneous ligation was greater than the sum of individual ligation of the two receptors (Carter et al., 1991), further demonstrating the promoting effect of CD19 on calcium flux in B cells.

The mechanisms underlying the positive effect of CD19 on calcium flux are multifold: IP3 is responsible for the release of intracellular calcium storage and, ultimately, the activity of the calcium release-activated calcium current that maintains the elevation of intracellular calcium. The IP3 comes from PIP2, which is synthesized by a phosphatidylinositol 4-phosphate 5-kinase (PIP5-kinase). Therefore, the finding that ligating CD19 alone modestly activated, and that co-ligating CD19 and membrane IgM strongly activated, PIP5 kinase in primary murine B cells suggested that CD19 may contribute to the B cell calcium response by regulating the availability of PIP2 (O'Rourke et al., 1998).

Other proposed mechanisms for CD19 to regulate calcium are via PI3K and Btk, although conflicting evidence exists. Some scientists believe while CD19 is not required for antigen-mediated activation of receptor proximal tyrosine kinases, it is critical for activation of PI3K. PI3K activation was found to be dependent on phosphorylation of CD19 Y484 and Y515, and antigen-induced CD19-dependent PI3K activation was required for calcium mobilization response (Buhl et al., 1997). The evidence from others, however, does not support the CD19/PI3K/calcium pathway by the finding that in the CD19-deficient mice, the BCR-induced calcium flux is normal (Rickert et al., 1995; Sato et al., 1997). Btk plays a critical role in BCR-mediated calcium, as has been reviewed previously. The role of CD19 in Btk activation was checked in a CD19 reconstituted myeloma model and CD19 gene-ablated animals. BCR-mediated Btk activation and phosphorylation were found to be dependent on the expression of CD19, while BCR-mediated activation of Lyn and Syk were not (Buhl et al., 1999). Wortmannin pre-incubation inhibited the activation and phosphorylation of Btk after BCR cross-linking and Btk activation was not rescued in a myeloma by expression of a CD19 mutant in which tyrosine residues Y484 and Y515 were changed to phenylalanine (Buhl et al., 1999). These findings postulate that the ability of CD19 to recruit and activate PI3K, which in turn activates Btk, would cause CD19 to enhance calcium flux. Again, this theory confronts contradictory evidence such as Akt activation being reduced in CD19-deficient B cells (Otero et al., 2001); PI3K activity and Akt activation being

normal in CD19-deficient mice (Fujimoto et al., 2002) and the combined loss of both CD19 and Btk having additive inhibitory effects on BCR-induced calcium responses in primary B cells (Fujimoto et al., 2002).

Recently, a new mechanism has been proposed to explain the role of CD19 in the calcium flux pathway: that is via sequestration of the Src family PTK Lyn (Fujimoto et al., 2001), a negative regulatory molecule for calcium flux (Smith et al., 1998). Indeed, Lyn has long been reported to associate with the cytoplasmic tail of CD19 (van Noesel et al., 1993). CD19 cross-linking may augment BCR-induced calcium response by sequestering the available pool of functional Lyn away from downstream negative regulatory proteins such as CD22. Consistent with this proposal, simultaneous CD19 engagement was reported not to enhance the BCR-induced calcium responses of Lyn- or CD22-deficient B cells over BCR ligation alone (Fujimoto et al., 2001). Thus, CD19 recruitment of Lyn may preferentially activate selective signalling pathways downstream of the CD19/Lyn complex to the exclusion of other downstream regulatory and effector pathways (Fujimoto et al., 2001).

MAP Kinase Activation

The other major *in vitro* molecular evidence that leads to the positive role of CD19 in primary B cells is the activation of MAP kinase. Co-ligating CD19 to surface IgM caused a 5- to 10- fold augmentation of the activation of the three MAP kinases: Erk2, JNK1 and p38, relative to the effects of ligating optimally BCR alone in primary murine B cells (Tooze et al., 1997). Similar results were also achieved in human B cell lines in which co-ligation of CD19 caused synergistic, prolonged enhancement of MAP kinase activity relative to ligation of either receptor complex alone (Li et al., 1997). These data indicate that CD19 has a positive impact on MAP kinase. Consistent with this, a further study demonstrated that tyrosine phosphorylation of Vav was markedly enhanced after CD19-BCR co-ligation and the mutation of Y391 in CD19 's cytoplasmic domain, the site at which Vav but not PI3K binds, blocked the enhancement of MAP kinase activation, suggesting that Vav is the factor linking CD19 to MAP kinase activation (Li et al., 1997).

The SH2 domain-containing transforming Shc protein has been implicated in MAP kinase activation via interacting with Grb2/Sos in Ras pathway (see previous section for details). Co-ligation of the BCR with CD19 increased the interaction of Shc with Grb2/Sos in both transformed and normal human B cells, whereas CD19 cross-linking alone induce neither Shc tyrosine phosphorylation nor translocation (Lankester et al., 1994). Besides, Grb2/Sos complexes were also found to be associated with native CD19. In mapping studies with altered constructs, it was found that CD19 Y330 and/or Y360 were necessary for binding to Grb2 and Sos (Brooks et al., 2000). Therefore, enhanced tyrosine phosphorylation and membrane translocation of Shc/Grb2/Sos complexes could form an additional mechanism for the activation of MAP kinase by co-stimulation of CD19.

The pathway leading to MAP kinase Erk2 activation from CD19 was further dissected in Daudi human B lymphoblastoid cells and compared with that from the BCR. While CD19-BCR co-ligation did not increase activation of Ras or Raf beyond that induced by ligation of sIgM alone, the co-engagement of CD19 with BCR resulted in the synergistic activation of MEK1 (Li et al., 1998), indicating a different pathway from CD19 to Erk activation. Furthermore, synergistic activation of Erk2 by CD19 occurred in the absence of changes in intracellular calcium and was not blocked by the loss of protein kinase C activity, demonstrating that the CD19-dependent Erk activation pathway does not involve calcium and PKC (Li et al., 1998). However, a later study by the same group reported that in CD19 induced Erk activation, PI3K, calcium and PKC were all required and that CD19 enhances the MAPK cascade at multiple levels, depending on the state of differentiation (Li et al., 2000). Thus the pathway from CD19 to Erk activation remains obscure.

Prolonging BCR Signalling in Lipid Rafts

Advances in membrane biology have led to the identification of glycosphingolipid- and cholesterol-rich plasma membrane microdomains, or lipid rafts, that have been proposed to function as platforms for both signal transduction and membrane trafficking (Simons et al., 1997). The important signalling molecules that have been identified as residents of these lipid microdomains include Src family PTKs Lyn, Lck, and Fyn (Casey et al.,

1995), and the ZAP-70 family PTK Syk (Stauffer et al., 1997). Following antigen binding, the BCR rapidly translocates into lipid rafts and is then subsequently internalised from the lipid rafts into the cell, a process that plays a role not only in the targeting of antigens that captured by the BCR for presentation, but also in the down-regulation of BCR signalling as well (Cheng et al., 1999). The role of the CD19/CD21 complex in the translocation of the BCR into lipid rafts was explored in the CH27 mouse B cell line (Cherukuri et al., 2001). After co-ligating CD19 with BCR by complement-tagged antigens, the CD19/CD21 complex was found to translocate together with the BCR into lipid rafts. Moreover, the presence of CD19/CD21 in the lipid raft caused by the co-ligation was demonstrated to significantly sustain BCR residency in lipid rafts, resulting in prolonged BCR signalling (Cherukuri et al., 2001). This result provides a novel additional mechanism to explain the positive function of CD19.

Src PTK Amplification

Src family protein tyrosine kinases are implicated in the initiation and propagation of BCR signalling. A novel biochemical basis for the positive role of CD19 was recently proposed, in which amplification of the Src PTKs, especially Lyn was mediated by CD19 (Fujimoto et al., 1999; Fujimoto et al., 2000). Lyn expression was reported to be required for CD19 tyrosine phosphorylation in primary B cells (Fujimoto et al., 2000). Furthermore, experiments with purified proteins demonstrated that CD19-Y513 was Lyn's initial phosphorylation and binding site (Fujimoto et al., 2000). This was proposed to lead to processive phosphorylation of CD19 -Y482, which recruited a second Lyn molecule, allowing for transphosphorylation and amplification of Lyn kinase activity (Fujimoto et al., 2000). Although it sounds feasible, a great defect of this model is its failure to explain the opposite phenotypes of CD19 and Lyn knockout mice. In order to test the upstream effect of CD19 on Lyn, a CD19 and Lyn double knockout mouse was generated by the same group. The phenotype of the mice deficient for both CD19 and Lyn, however, did not look like that of CD19-deficient mice as would be expected under this model. Instead, CD19-deficiency suppressed the hyper-responsiveness of Lyn-deficient B cells and the autoimmunity characterized by serum auto-antibodies and immune complex-mediated glomerulonephritis in Lyn-deficient mice (Hasegawa et al., 2000). In addition, the enhanced intracellular calcium responses

following BCR ligation that typifies Lyn deficiency were delayed, rather than normalized, by the loss of CD19 expression (Hasegawa et al., 2001). These findings demonstrate that although it is possible for CD19 to amplify Src family PTK members—the tyrosine phosphorylation of Fyn and other cellular proteins induced following BCR ligation was dramatically reduced in CD19/Lyn double knock-out B cells relative to Lyn knock-out B cells (Hasegawa et al., 2000)—Lyn and CD19 are each engaged in the two extremes of the signalling scale. Rather than being dependent on each other, knocking out both CD19 and Lyn may bring BCR signalling back to balance.

1.4.2: Negative Regulation of BCR Signalling By Lyn

After initiation and propagation, a well-balanced signal needs a negative feed-back loop for termination when complete or to prevent inappropriate activation. Among dozens of negative regulators in B lymphocyte, the protein tyrosine kinase Lyn is a double-edged one. As a Src family member, Lyn is involved in signal initiation and amplification. These positive roles of Lyn in BCR regulation, however, are redundant and can be substituted by other Src family PTK members, because BCR signalling can still occur in its absence although in a delayed fashion (Chan et al., 1997). The hyper-responsive phenotype of Lyn-deficient mice, however, demonstrated that the unique function of this protein tyrosine kinase lies in its negative side. The molecular mechanism of negative regulatory role of Lyn can be summarized as follows.

1.4.2.1: Phosphorylating Negative Receptors

The negative regulatory mechanisms of B cells involves the engagement of several surface molecules, which can moderate the B cell's response to antigenic stimulation. These surface molecules are called negative receptor for BCR and their phosphorylation depends, to a great extent, on Lyn.

FcγRIIb1

When antigen is present in the form of immune complexes with IgG, as would occur late in immune responses, antigen binding to the BCR of specific B cells leads to co-ligation of the BCR and the receptor for Fc portion of immunoglobulin, Fc γ RIIb1 (Cassel et al., 1993; Muta et al., 1994), inhibiting B cell activation so as to stop production of too much antibody (Phillips and Parker, 1983). Indeed, Fc γ RIIb1-deficient mice exhibit elevated antibody responses, particularly at late times after immunization (Takai et al., 1996). Co-ligation of the BCR and Fc γ RIIb1 led to phosphorylation of a tyrosine in the cytoplasmic domain of Fc γ RIIb1 that is critical for its inhibition of BCR-induced elevation of intracellular free calcium and activation of Ras pathway (DeFranco et al., 1995; Hippen et al., 1997; Tridandapani et al., 1997). After tyrosine phosphorylation, the cytoplasmic domain of Fc γ RIIb1 serves as a recruitment site for two phosphatases: SH2-containing inositol 5-phosphatase (SHIP) and SH2-containing protein tyrosine phosphatase-1 (SHP-1) (Ono et al., 1996; D'Ambrosio et al., 1995). Both dampen the BCR-signal, although SHIP appears to be the more important in mediating the inhibitory effects of Fc γ RIIb1 in B cells (Ono et al., 1997; Nadler et al., 1997).

The inhibitory function of Fc γ RIIb1 in Lyn-deficient mice was first checked in 1996 when it was found that the B cells from young Lyn-deficient mice were hyper-responsive to anti-IgM-induced proliferation, and co-ligation of Fc γ RIIb1 receptor with the BCR on Lyn-deficient primary B cells failed to suppress the BCR-induced proliferation, while it could on control B cells (Wang et al., 1996). The defective inhibition of proliferation by Fc γ RIIb1 in absence of Lyn was later confirmed (Chan et al., 1997). Furthermore, it was also reported that the negative regulation of Erk and calcium by Fc γ RIIb1 were partly impaired in Lyn-deficient mice (Chan et al., 1998). The phosphorylation of Fc γ RIIb1 in Lyn-deficient mice as a biochemical basis for the defective function of this receptor was therefore examined and found to be reduced (Chan et al., 1998; Nishizumi et al., 1998), consistent with the idea that Lyn plays an important role in the phosphorylation of Fc γ RIIb1 on its inhibitory tyrosine upon co-ligation with BCR. However, the fact that the inhibitory function of Fc γ RIIb1 are still partly present in Lyn-deficient primary B cells leads to the presumption that Lyn must have affected other inhibitory pathway(s) in addition to Fc γ RIIb1.

CD22

CD22 is a B cell restricted member of the sialoadhesin family of adhesion molecules (Kelm et al., 1994). After BCR or CD22 cross-linking, CD22 is rapidly tyrosine phosphorylated (Schulte et al., 1992; Peaker et al., 1993), facilitating recruitment of a number of intracellular signalling molecules including SHP-1 (Doody et al., 1995; Campbell et al., 1995), Lyn, Syk, PI3K and PLC- γ (Tuscano et al., 1996; Tuscano et al., 1996; Law et al., 1996). Although it may also serve a positive role in some contexts (Cyster et al., 1997; Tuscano et al., 1996), CD22 appears to be an inhibitory receptor because B cells from CD22-deficient mice show enhanced BCR-induced calcium elevation (O'Keefe et al., 1996; Otipoby et al., 1996; Sato et al., 1996), which is reduced after co-ligation of CD22 with BCR in wild type primary B cells (Xu et al., 2002), and activation of MAP kinase pathways is suppressed when CD22 is co-ligated into the BCR signalling complex but enhanced when CD22 is separately ligated before BCR engagement (Tooze et al., 1997). The inhibitory phosphatase SHP-1 recruited (Law et al., 1996; Doody et al., 1995) is a strong candidate for mediating the inhibitory effect of CD22.

To examine the inhibitory role of CD22 in Lyn-deficient B cells, an anti-CD22 antibody was used to sequester CD22 prior to BCR stimulation. This treatment enhanced anti-IgM-induced calcium elevation in wild-type B cells, consistent with the negative regulatory role of CD22 in calcium pathway. The sequestration of CD22, however, failed to raise the elevated calcium flux in the Lyn-deficient B cells following BCR ligation although it was not maximum (Chan et al., 1998), suggesting that the ability of CD22 to down-regulate the BCR-induced calcium response was critically dependent upon Lyn. The requirement of Lyn for CD22-mediated calcium inhibition in primary B cells was not only repeated by others (Smith et al., 1998; Cornall et al., 1998), but also the primary role of Lyn in phosphorylating CD22 (Smith et al., 1998; Nishizumi et al., 1998), and recruiting SHP-1 (Smith et al., 1998) were established. Recently, in order to further investigate the role of Lyn kinase in setting signalling thresholds for BCR, Lyn^{up/up} mice were generated, in which a gain-of-function mutation analogous to the Src Y527F-activating mutation was introduced into the Lyn gene, and resulted in sustained activation of Lyn in these mice (Harder et al., 2001; Hibbs et al., 2002). The finding that Lyn^{up/up} primary B cells have constitutive phosphorylation of CD22 and SHP-1 (Hibbs et

al., 2002) further strengthens the role of Lyn in phosphorylating CD22, which in turn recruits SHP-1.

CD72

CD72, formerly called Lyb-2, is a 45 kDa type II transmembrane glycoprotein expressed primarily on B cells as a disulfide-linked homodimer from the pro-B through the mature B cell stage, but downregulated on terminally differentiated plasma cells (Nakayama et al., 1989; Sato et al., 1976; Von Hoegen et al., 1990). This surface protein has a 95 amino acid cytoplasmic domain that contains two potential ITIMs (Adachi et al., 1998). Initial signalling studies on CD72 classified it as a positive modulator of B cell responses since anti-CD72 was reported to induced tyrosine phosphorylation of a variety of proteins including PLC- γ and CD19, and to activate Lyn, Blk and Btk (but not Syk) kinases (Venkataraman et al., 1998a; Venkataraman et al., 1998b). However, the evidence that a small amount of protein phosphatase SHP-1 was immunoprecipitated with CD72 from the WEHI-231 B cell line and that cross-linking of the BCR enhanced both tyrosine phosphorylation of CD72 and association of CD72 with SHP-1 in these cells (Adachi et al., 1998) suggested that CD72 might be a negative regulator of BCR signalling via SHP-1 (Adachi et al., 1998; Adachi et al., 2001). In order to elucidate the function of CD72 in B cell activation, the homozygous CD72-deficient mice was generated by targeted gene inactivation (Pan et al., 1999). The phenotype of CD72^{-/-} mice indicates that CD72 plays a non-redundant role *in vivo* and negatively regulates responsiveness of B cells.

The phenotype of CD72^{-/-} mice is similar to that of Lyn-deficient mice in that B cells from both are hyper-responsive to BCR cross-linking and LPS stimulation (Pan et al., 1999; Wang et al., 1996; Cornall et al., 1998). These similarities suggest that Lyn might be involved in the signalling pathway utilized by CD72. Consistent with this hypothesis, Lyn has been shown to tyrosine phosphorylate CD72 in an *in vitro* assay (Adachi et al., 1998). However, Lyn deficiency does have broader effects than CD72 deficiency including overt autoimmune disease with autoantibody production and glomerulonephritis, which are not observed in CD72-deficient mice, suggesting additional effectors of Lyn in the negative regulation of BCR signalling.

PIR-B

Another ITIM-containing surface molecule that may be employed by Lyn for negative regulation is Paired Immunoglobulin-like Receptor-B (PIR-B). Based on RNA and RT-PCR analysis, expression of PIR-B is restricted to B cells and myeloid cells (Hayami et al., 1997; Kubagawa et al., 1997). While the overall structure of PIR-B shows homology to several Ig-superfamily members, its striking feature is the presence of four sets of ITIM-like sequences in the cytoplasmic tail (Maeda et al., 1998). Synthetic phosphotyrosyl peptides corresponding to the third and fourth ITIMs of PIR-B can bind SHP-1, SHP-2 and SHIP from macrophages and B cell line lysates (Yamashita et al., 1998), indicating these enzymes could be recruited for the inhibitory function of PIR-B. Further study showed that the PIR-B mediated inhibition was markedly reduced in the SHP-1 and SHP-2 double-deficient DT40 chicken B cells, but unaffected in SHIP-deficient cells, suggesting that PIR-B negatively regulates BCR activation by the redundant functions of SHP-1 and SHP-2 (Maeda et al., 1998). Consistent with this result, SHP-1 and SHP-2, rather than SHIP, were found to be co-immunoprecipitated with PIR-B (Blery et al., 1998), and over-expression of a catalytically inactive form of SHP-1 prevented the PIR-B-mediated inhibition of tyrosine phosphorylation of Syk, Btk, and PLC- γ 2 (Maeda et al., 1999).

The association of Lyn with the inhibitory activities of PIR-B is supported by experiments in both mice and cell lines. In mice, constitutive tyrosine phosphorylation of PIR-B molecules on macrophages and B cells was observed, irrespective of the cell activation status. These constitutively phosphorylated PIR-B molecules were associated with the Lyn and SHP-1, and in Lyn-deficient mice, PIR-B tyrosine phosphorylation was greatly reduced (Ho et al., 1999). In a B cell line, however, PIR-B phosphorylation required co-ligation with the BCR (Ho et al., 1999; Maeda et al., 1999), but is completely abolished in the Lyn-deficient DT40 cells (Maeda et al., 1999). These results suggest that the Src family member Lyn plays an important role in tyrosine phosphorylation of the inhibitory molecule PIR-B, irrespective of BCR co-ligation.

1.4.2.2: Phosphorylating Adaptor Molecules

Adaptor molecules are commonly referred to as proteins that possess protein-protein or protein-lipid interaction domains, such as SH2, SH3, or PH domains, but do not have enzymatic activity. This distinguishes them from kinases and phosphatases, which also have these interaction domains and can serve as adaptors as well as enzymes. In this concept, certain co-receptors such as CD22 and PIR-B can be regarded as adaptor molecules. Since the role of Lyn in phosphorylating these surface molecules has been discussed above, only non-receptor adaptor molecules involved in the negative regulation of BCR signalling and their relationship with Lyn will be reviewed here.

Dok (Downstream of tyrosine kinase) is a family of adaptor molecules that modulates immunoreceptor, cytokine and growth factor signalling in a variety of hematopoietic lineages. These molecules share an N-terminal PH domain, a central phosphotyrosine binding domain (PTB) and a C-terminus motif that allows for association with both SH2- and SH3- containing molecules (Jones et al., 1999; Suzu et al., 2000; Veillette et al., 2002; Yamanashi et al., 2000). The inhibitory function of the Dok proteins in B cells is associated with Fc γ RIIb (Tamir et al., 2000). Co-ligating Fc γ RIIb with the BCR resulted in increased tyrosine phosphorylation of p62Dok, with a concomitant increase in its binding to RasGAP, a negative regulator of Ras (Tamir et al., 2000). Furthermore, B cells from p62Dok^{-/-} animals demonstrate elevation of MAPK activity and proliferation following co-engagement of the BCR and Fc γ RIIb, consistent with a negative role for Dok in MAP kinase regulation (Yamanashi et al., 2000). It is therefore proposed that following receptor ligation, Dok-1 (p62Dok) is recruited to the cell membrane via association of its PTB domain with phosphorylated residues within SHIP, which in turn is recruited to the membrane via association of its SH2 domain with phosphorylated Fc γ RIIb, a substrate of Lyn. Besides, Lyn may also be involved in the direct phosphorylation of the p62Dok, because in Lyn-deficient primary B cells, the phosphorylation of p62Dok is abolished in both BCR cross-linking alone and co-ligation with Fc γ RIIb (Yamanashi et al., 2000).

Phosphoprotein associated with glycosphingolipid-enriched microdomains (PAG, or cbp for Csk binding protein) has emerged as a potentially critical regulator of Src family kinase activity through its association with the cytosolic protein tyrosine kinase (Csk)

(Nada et al., 1991; Brdicka et al., 2000; Kawabuchi et al., 2000). Like Dok protein, PAG contains several phosphorylatable tyrosines for SH2 binding and two potential SH3 binding sites. Based on analysis of T cells, in which the role of PAG has been extensively studied, the following model has been suggested in B cells (Kurosaki et al., 2002): In the resting state, raft-associated PAG recruits Csk to the plasma membrane via its phosphorylated tyrosine and therefore activates Csk (Takeuchi et al., 2000). Activated Csk then phosphorylates the C-terminus tyrosine of Src family PTKs in the lipid raft, which makes the Src PTKs inactive (Hata et al., 1994). Upon receptor cross-linking, PAG becomes de-phosphorylated, as is the case of T cells, by an as yet unidentified phosphatase and releases Csk (Brdicka et al., 2000). The absence of Csk in the lipid raft removes the inhibition on Src PTKs.

An important extension of this model, assuming that PAG is phosphorylated again during the course of signalling, is that the restoration of the PAG-Csk interaction might contribute to the termination of Src-family PTKs activity. The PTK that is responsible for PAG phosphorylation in B cells might be Lyn, although this has not been tested directly. If so, then the Lyn that is activated on BCR ligation could inhibit the kinase activities of Src-family PTKs, including itself, by recruiting Csk to the rafts (Kurosaki et al., 2002). In support to this model, Lyn-deficiency has been reported to enhance Fyn-dependent signals and degranulation in mast cells (Parravicini et al., 2002).

1.4.2.3: Kinase –Independent Inhibition

Apart from phosphorylating some negative receptors or adaptor molecules, the mechanisms of Lyn in the negative regulation of BCR signalling were also include tyrosine kinase-independent function. Given Lyn's important physical location in the lipid rafts of the plasma membrane where most of the signalling activators and substrates reside, the presence of Lyn in the cell membrane itself could prevent the translocation of other cytosolic signalling molecules to the membrane where they would gain access to their physiological substrates or activators. One such example is that Lyn was found to be able to inhibit PKC activation without requiring its kinase activity (Katsuta et al., 1998). In DT40 chicken B cell lines, the absence of Lyn caused elevated PKC activation after BCR cross-linking but did not change the level of expression, compared with that of

control cells. This elevation of PKC activity in Lyn-deficient cells, however, was completely reversed to wild-type level by the transfection of the kinase-inactive LynKL vector, indicating that the tyrosine kinase activity of Lyn is not required for this inhibition of PKC activity. (Katsuta et al., 1998).

1.4.2.4: Phosphorylating a negative regulatory site on Syk:

Understanding the signalling role of Lyn is complicated by the fact that phosphorylation of both positive and negative signalling molecules has been found to require this Src family PTK. Syk is a positive effector of BCR-stimulated responses because disruption of this gene results in pronounced defects in calcium signalling and B cell development (Turner et al., 1995; Cheng et al., Takata et al., 1994). Following its recruitment to the BCR, Syk becomes phosphorylated on multiple tyrosines, including three (Tyr-317, -342, and -346) in the linker region that separates the tandem SH2 domains from the C-terminal catalytic domain (Keshvara et al., 1998). The phosphorylation of Tyr-342, -346, or both creates a binding site for PLC γ (Law et al., 1996). The phosphorylation of Tyr-317, however, creates a binding site for c-Cbl, an adaptor protein that serves as a negative regulator of BCR-stimulated calcium signalling (Lupher et al., 1998; Yankee et al., 1999). In DT40 B cells that lack the Src family kinase Lyn, the phosphorylation of the inhibitory Tyr-317 was found to be suppressed, leading to elevated production of IP3 and an amplified calcium signal (Hong et al., 2002). Although this result came from a cell line in which Lyn is the only Src family PTK and needs to be confirmed in other cell system, it at least broadens our view that the mechanisms of Lyn in negatively regulating BCR signalling could also extend to modulating positive signalosomes, apart from promoting inhibitory signalling molecules.

1.5: THE AIMS OF THE THESIS:

Lyn is mainly involved in the negative regulation of B cell receptor-mediated signals, although positive signalling events are also associated with this protein tyrosine kinase based on the fact that it is the predominant Src family PTK expressed in B cells and that the constitutive activation of Lyn results in autoimmunity just as the absence of Lyn does (Hibbs et al., 1995; Harder et al., 2001; Hibbs et al., 2002). The mechanisms for Lyn as

a negative regulator of BCR signalling identified so far have been summarized above and mainly involve phosphorylation of some BCR negative co-receptors, which in turn recruit and activate protein or lipid phosphatases to down-regulate BCR-induced signals. However, some of the hyper-responsive phenotypes of Lyn-deficient B cells are still present in these phosphatase-deficient B cells (Li et al., 1999), and some of the inhibitory effects of BCR co-receptors are still functional in Lyn knock-out mice (Chan et al., 1997; Chan et al., 1998), suggesting some independent negative regulatory mechanisms between Lyn and the phosphatase, as well as the possible existence of novel molecules or signalling pathways that are negatively regulated by Lyn.

This thesis examines the roles of Lyn in regulating signal transduction from the BCR. We first investigate the molecular interaction between Lyn and CD19, an important B cell specific co-receptor and signalling modulator, by assessing Lyn and CD19 membrane localization, as well as the phosphorylation and function of each molecule in the absence of the other. Finally, a novel inhibitory role of Lyn in PI3K activation is described and a mechanism proposed.

CHAPTER 2: MATERIALS AND METHODS

2.1: MEDIA

The following media were prepared by the Walter and Eliza Hall Institute media department. Media were sterilized by filtration through a 0.22 μm membrane filter and stored at 4 ° C.

Complete RPMI was used for cell culture and where otherwise indicated. This media consisted of RPMI 1640 supplemented with 2-ME and 5% FCS (*see solutions and supplements*).

Ken D. Shortman's Balanced Salt Solution (KDS/BSS) was prepared to mouse tonicity by adding 0.15M NaCl, 0.004M KCl, 0.002M CaCl₂, 0.001M MgSO₄, 0.001M KH₂PO₄, 0.0008M K₂HPO₄ and 0.015M Hepes buffer to Milli Q water, pH to 7.2.

Kelso DME was prepared to mouse tonicity by dissolving 4g glucose, 6mg folic acid, 36mg L-asparagine, 116mg L-arginine HCl, 2g NaHCO₃, 10mM Hepes, 60mg penicillin and 100mg streptomycin to 1 litre Dulbecco's Modified Eagle's Medium (Gibco cat no 430-1600).

HEPES Eagle's Medium (HEM) was prepared to mouse tonicity by dissolving a 1 x 10 litre packet of Minimum Essential Medium (Cat. No. 41500-018, Gibco BRL, Grand Island, NY, USA), 160 mL of a 1 M HEPES solution, 1.0g penicillin and 1.0g streptomycin in 8.75 litres of Milli Q water. pH to 7.2 with NaOH.

Phosphate Buffered Saline (PBS), pH 7.3, (0.02M PO₄) was prepared to mouse tonicity by dissolving 57g of Na₂HPO₄·2H₂O, 12g of Na₂H₂PO₄·2H₂O and 174g of NaCl in 20 litres of Milli Q water. For use in immunofluorescent staining, PBS was supplemented with 3% foetal calf serum.

Red Cell Removal Buffer (RCRB), pH 7.3, was prepared by dissolving 155.8g NH_4Cl , 0.74g ethylenediaminetetra-acetic acid (EDTA)-disodium salt and 20g NaHCO_3 in 20 litres of Milli Q water.

RPMI 1640 was prepared to mouse tonicity by dissolving a 1 x 10 litre packet of RPMI 1640 (Cat. No. 50-020-PB-R, TRACE Biosciences Pty. Ltd., Australia), 9.0g NaCl , 20g NaHCO_3 , 1.1g sodium pyruvate, 1.0g penicillin and 1.0g streptomycin in 10 litres of double distilled water.

2.2: SOLUTIONS AND SUPPLEMENTS:

Asparagine and Glutamine were supplied by WEHI media department and made into 100mM and 200mM stock with Milli Q water respectively. For cell culture, they are used in 1:100 dilution in Kelso DME.

β -Mercaptoethanol (2-ME) was purchased from Sigma, Sydney, Australia. For cell culture, it is diluted to 100mM in HEM (50 μl of 2-ME in 6.5 ml of HEM) and further diluted in Kelso DME to a final dilution of 100 μM (100 μl in 100 ml).

Dimethyl Sulphoxide (DMSO) 99.5% was purchased from BDH, MERCK Pty. Ltd., Australia.

Foetal Calf Serum (FCS) was supplied by CSL Ltd., Melbourne, Australia. The FCS was heat-inactivated in a 56°C waterbath for 60 mins and then stored at – 20°C.

FAM Culture Media for wt type B cell line: To 100 ml Kelso DME, add 8 ml of FCS, 1 ml of 100mM Asparagine, and 100 μl of above-made 2-ME.

FGM Culture Media for *lyn*-deficient B cell line: To 100 ml of Kelso DME, add 5 ml of FCS, 1 ml of 200mM Glutamine, and 50 μl of above-made 2-ME.

Freezing Media for B cell lines (6 ml): 600 μl of DMSO; 1.2 ml of FCS; and 4.2 ml of Kelso DME containing 10% FCS. Cells are Freezed at 1 ml/vial into –70 C for 24 -48hrs before put into liquid N2.

Propidium Iodide (Calbiochem, CA, USA) was stored at 100 µg/mL in PBS at 4°C and used at a final concentration of 1 µg/mL for FACS analysis and sorting.

Rabbit Complement was purchased from C-six Diagnostics Inc., Winconsin, USA. Each batch was tested to ensure it was capable of killing anti-CD4, anti-CD8 and anti-Thy 1 monoclonal antibody labelled T cells.

Coommassie Blue Staining Solution: 10% Methanol, 10% Acetic Acid, 0.1% Coommassie Blue R-250.

Gel was stained for about 15 min at room temperature, then de-stained in 10% acetic acid plus 20% methanol overnight.

Digestion Buffer for DNA extraction from B cell lines. 100mM of Tris (pH8.0), 5 mM of EDTA (pH 8.0), 0.2% w/v of SDS, 200mM of Na Cl and 100µg/mL of proteinase K. This solution was stored at room temperature without the proteinase K, which was stored at -20°C and added just prior to use.

ELISA Blocking Solution comprised PBS with 0.6% weight to volume skim milk powder, 0.05% Tween-20 and 1% FCS. This solution was stored at 4 °C.

Lau Lysis Buffer: 100 mM NaCl; 10 mM Tris-HCl (pH 7.5); 2 mM EDTA; 1% NP 40.

Lipid Re-suspension Buffer (re-useable): 20 mM Tris (pH 7.4); 1 mM MgCl₂; 1mM EGTA.

Lyn Kinase Buffer: 25 mM Tris (pH 7.5), 0.5 mM DTT; 0.1 mM NaVO₄; 50 µM cold ATP; 10 mM MgCl₂.

MACS Buffer: PBS supplemented with 2mMEDTA and 0.5% Bovine Serum Albumin (BSA).

PI₃Kinase Reaction Buffer: 20 mM Tris (pH 7.4); 5 mM MgCl₂.

Sodium Ortho Vanadate Stock Solution (10 x): 100mM Sodium Ortho Vanadate (Na_3VO_4)* in Milli Q Water

* Na_3VO_4 was activated for maximal inhibition of protein phosphotyrosyl-phosphatases. After making up the stock solution, the pH was adjusted to 10, the solution transferred to a 100 ml glass bottle and boiled in microwave till colourless. When cool, the pH was re-adjusted to 10. This process was repeated till solution remained colourless and pH stabilized at 10.

RIPA Lysis Buffer: 20 mM Tris (pH 7.5); 150 mM NaCl; 1 % Triton X-100; 1 % Sodium Deoxycholate; 0.1% SDS

SDS Sample Buffer (2 x): 0.01% Bromophenol blue, 4% SDS, 20% Glycerol, 125mM Tris-HCl (pH 6.8), 2.5% β Mercaptoethanol.

Stripping Buffer: 100 mM 2-mercaptoethanol, 2% SDS, 62.5 mM Tris (pH 6.7).

TNEV Buffer: 10 mM Tris-HCl, pH7.5, 150 mM NaCl, 5 mM EDTA, 1 mM Na_3VO_4

TLC Plate Coating Solution: 1% Oxalic acid (dipotassium monohydrate); 1 mM EDTA; 40% Methanol.

(10 g of Oxalic acid + 2 ml of 500 mM EDTA + 400 ml of Methanol in 1 L dd water)

TLC Tank Solution:

Propan-1-ol	130 ml
Glacial acetic acid	8 ml
Phosphoric acid	0.68 ml
DD water	62 ml
<hr/>	
Total	200 ml

2.3: CELL LINES AND MICE

2.3.1: B Cell Line Genotyping

PCR assays specific for *lyn*^{-/-} and corresponding wild type alleles were performed on each cell line to confirm genotypes. The DNA was extracted from 1 x 10⁶ cells by lysing the cells in 500 µl of Digestion buffer for 1 hour at 55 °C /1350 rpm shaking. After spinning down debris, supernatants were transferred into new tubes and an equal volume of isopropanol (500 µl) added to precipitate DNA. After washing with 70% EtOH, the DNA was resuspended in 100 µl of 8 mM NaOH with agitation for 30 mins. Once solubilized, 40 µl of 45mM Hepe was added with 360 µl of dH₂O to give a final volume of 0.5ml.

All PCR were carried out in a 20 µl volume using the following mixture:

2 µl of 10 x PCR buffer (Perkin Elmer), 2 µl of 10 x dNTPs (Pharmacia Biotech) (5 µM), 1.6 µl of MgCl₂ (2.5mM), 2 µl of Primer (20µmol), 0.3µl of Taq Polymerase (Perkin Elmer) (10 Units), and 5.1 µl of dH₂O, before adding 1 µl of sample DNA.

The primers and conditions used for each genotype are as follows:

Common Forward Primer 5'-CGGCCTTCATATCCATGATTCAC-3'

Wt Reverse Primer 5'-CAGGTGGAGCATACTGGCTGTTT-3'

lyn^{-/-} Reverse Primer 5'-CCTTGGGAAAAGCGCCTCCCCTAC-3'

PCR products were generated by 35 cycles of 95°C for 30s, 60°C for 30s, and 72°C for 30s, with 72°C for 1' 30s at last. The products were analysed on a 2% agarose gel and bands visualised using ethidium bromide fluorescence.

2.3.2: Mice Strains

***lyn*^{-/-} Mice** The generation of the *lyn*^{-/-} mice has been described (Hibbs et al., 1995). Mice were originally a C57BL/6 x 129/Sv inter-cross before an 11th generation C56BL/6 backcross line was established.

***CD19*^{-/-} Mice** CD19-deficient mice were obtained by inactivation of the CD19 gene in embryonic stem cells (Rickert et al., 1995), and subsequent germline transmission

of the mutant allele through the generation and breeding of chimaeric mice. The mice are an 11th generation C57BL/6 backcross.

Xid Mice Xid mice (CBA/N) containing a point mutation in Btk PH domain and their wild-type control mice (CBA/Ca) were maintained in WEHI Animal Facility.

***cd45*^{-/-} Mice** *cd45*^{-/-} mice were generated by targeted deletion of exon 12 of the *cd45* gene, which encodes part of the extracellular domain and is common to all CD45 isoforms (Mee et al., 1999). The mice are more than 11th generation of C57BL/6 backcross.

2.4: ANTIBODIES

The names, specificities and sources of antibodies and related reagents used in the work described in this thesis are listed in Table 2.1.

Table 2.1 Antibodies

Specificity	Name/Host	Derivation/Purchasing source
CD19	ID3	Krop et al., 1996
FcγR I and II	2.4G2	Unkeless et al., 1979
CD45R (B220)	RA3-6B2	Coffman and Weissman, 1981
CD22.2	Cy34	Symington et al., 1982
CD5 (Ly-1)	53.7.8	Ledbetter and Herzenberg., 1979
IgM	331.12	Kincade et al., 1981
Igκ	187.1	Hybridoma 1:5-11, 1981
CD43	S7	Gulley et al., 1988
Thy-1	30H12	Ledbetter and Herzenberg, 1979
CD4	3155	Sarmiento et al., 1980
CD8	RL 172.4	Malek et al., 1983
IgD	11-26C	Southern Biotech. Assoc.
Phospho-tyrosine	4G10	Upstate Biotech.
IκBα	Mouse monoclonal	Cell Signalling Technology
Vav	Mouse monoclonal	Cell Signalling Technology
Lyn	Rabbit antiserum	Santa Cruz Biotech.

Erk2	Rabbit antiserum	Cell Signalling Technology
Phospho-Erk1/2	Rabbit antiserum	Cell Signalling Technology
CD19	Rabbit antiserum	Dr. James Bolen from Millennium Pharmaceuticals, Boston, MA
CD22	Rabbit antiserum	Dr. P. Crocker, Dundee University United Kingdom
BCAP	Rabbit antiserum	Dr. T.Kurosaki, Kansai Medical University, Japan
pIκBα	Rabbit antiserum	Cell Signalling Technology
Vav	Rabbit antiserum	Santa Cruz Biotech
Akt 1	Goat polyclonal IgG	Santa Cruz Biotech
Phospho-Akt	Rabbit antiserum	Cell Signalling Technology
PI3K	Rabbit antiserum	Upstate Biotech
IgM Ltd	Goat F(ab') ₂ Ab	Jackson ImmunoResearch
IgM	Goat Inact Ab	Southern Biotech. Assoc.
Rabbit Ig	HRP-Conjugated Sheep Ab	Silenus, Chemicon, Australia
Goat Ig	HRP-Conjugated Donkey Ab	Silenus, Chemicon, Australia
Mouse IgG2a	HRP-Conjugated Goat Ab	Southern Biotech. Associ.
Mouse IgG2b	HRP-Conjugated Goat Ab	Southern Biotech. Associ.
Actin	HRP-Conjugated Goat Ab	Santa Cruze Biotech

2.5: CELL PREPARATIONS

2.5.1: *In vitro* Cell Lines Culture After a quick thawing, B lymphoma cell lines were washed and resuspended in 5 ml of their preferred media, diluted in 1:1, 1:2 and 1:4 for 7 day's growth at 37°C before splitted at 1:3 and 1: 20 dilution later on.

2.5.2: Standard Splenic Cell Preparations Mice were sacrificed by CO₂ asphyxiation and the spleens removed and placed into complete RPMI containing 1%FCS . Single cell suspensions of spleens were obtained by cutting the spleens into small pieces and gently pushing the organs through a wire sieve. Cells were then resuspended in RCRB at room temperature for 30 seconds, centrifuged and then

washed and resuspended in PBS/FCS. Cells were finally passed through nylon mesh to remove aggregates.

2.5.3: B Cell Enrichment by Complement Killing B cells were enriched from pooled spleen cell suspensions by complement killing of T cells. Cells were centrifuged and resuspended at 10^7 cells/mL in the supernatants from the hybridoma cell lines 30H12(anti-Thy-1), 3155 (anti-CD4) and RL 172.4 (anti-CD8) in a 1:1:1 ratio for 30 mins on ice. Cells were again centrifuged to remove unbound antibody and resuspended in RPMI containing 1% FCS and rabbit complement. The cells were then transferred to tissue culture petri dishes (Falcon, New Jersey, USA) and incubated at 37°C 10% CO_2 for 40 mins. Non-adherent cells were recovered and washed in complete RPMI twice and passed through nylon mesh to remove dead cell aggregates.

2.5.4: B Cell Enrichment by MACS Columns Single cell suspensions were made from mice spleens by standard preparation method, washed in PBS, and cell pellets was resuspended in MACS buffer (450 μl /spleen). After incubation with MicroBeads coated either with anti-rat Ig or anti-CD45R (B220) mAbs (Miltenyi Biotec, Auburn, CA) (50 μl / spleen) for 15 min at 4°C , the cells were washed once with 10-20 x labelling volume of buffer then re-suspended in MACS buffer (500 μl /spleen) for magnetic separation. 3 x 1 ml of degassed MACS buffer was applied on the top of column placed in the MidiMACS Separation Unit before running through the magnetically labelled cell suspension, and washing the column with 3 x 2 ml buffer. The total effluent was collected as negative fraction (negative selection). For positive selection, the column was removed from separator and placed on a new collection tube. After 5 ml of buffer was applied to the reservoir of the column, it was firmly flushed out using a plunger into the collection tube.

2.5.5: Immunofluorescence Labelling and Flow Cytometry Cell suspensions were incubated at 0.5×10^6 per well on ice for 30 mins with fluorescent-conjugated antibody diluted in PBS/FCS to an appropriate concentration. After washing twice, cells were resuspended in PBS/FCS and propidium iodide was added at $1 \mu\text{g/mL}$ for dead cell exclusion. Cells were analysed on a FACScan (Becton Dickinson, San Jose,

CA) for different surface markers, or isolated by sorting using a MoFlo (Cytomation, Fort Collins, Colorado, USA) for specific cell populations.

2.6: BIOTINYLATION OF PROTEINS (ANTIBODIES)

Dialysis tubing with a diameter of 1 cm and pore size of 12-14 x 10³ kD was chosen, and boiled in 1 % NH₄CO₃ to activate the tube. Protein (antibody) was then dialysed against 1 litre of 0.1M NaCO₃ (pH 8.2-8.6) overnight at 4°C. Protein (antibody) was transferred in a screw-cap tube on the bench and adjusted to be 1 mg/ml with 0.1M NaHCO₃. Biotin succinimide ester (Biotin-N-Hydroxy Succinimide Ester NHS-d-Biotin, Sigma H-1759) was weighed out into a glass vial and dissolved in DMSO (Dimethylsulfoxide, Sigma D-8779) to 1 mg/ml immediately before use. 120 µl biotin per 1 ml of protein (antibody) was mixed and rotated at room temperature for 4 hours. After dialysis against 2 changes of 1 litre PBS each overnight at 4 °C for 2 nights, the conjugation was tested by staining with a titration of decreasing amounts of conjugate.

2.7: LIPID RAFT ISOLATION

100 x 10⁶ cells were lysed in 1 ml of TNEV Buffer, plus 1% Triton X-100 on ice for 30 min. After centrifugation for 10 min at 3000 rpm on a bench top centrifuge at 4 °C, the cleared lysates were diluted 1 : 1 with 85% (w/v) sucrose in TNEV. 6 ml of 35% and 3.5 ml of 5% sucrose in TNEV were then in turn overlaid on top of the diluted lysates. Lipid rafts from the cells were floated toward top by ultracentrifuging the sample at 33,500 rpm (200,000 g) for 16 hours at 4 °C in SW40Ti rotor. 1 ml fractions from the top to the bottom were collected into eppendorf tubes to be analysed by direct western blot.

2.8: CELL BIOCHEMISTRY

2.8.1: Cell Stimulation and Lysate Preparation

After washing with PBS, the cells were resuspended at 20-40 x 10⁶ /ml in 0.5 ml PBS, and pre-warmed at 37 °C for 5 min before stimulation. Where inhibition of kinases was required, the cells were incubated with specific inhibitors at 37 °C for an additional 20-30 min. Cells were generally stimulated with Goat anti-mouse IgM at different time points at the specified concentrations. Co-ligation of the BCR with

CD19 was done by staining B cells with biotinylated monoclonal antibodies (Mabs) specific for Ig κ and CD19, either alone or together. Fc γ RIIb binding was blocked by saturating concentrations of 2.4G2. Cross-linking of biotinylated Mabs for co-ligation was achieved by addition of avidin to a final concentration of 20 μ g/ml. For Fc γ RIIb co-ligation, purified splenic B cells were treated with either buffer alone, F(ab')₂ goat anti-mouse IgM at 40 μ g/ml or intact goat anti-mouse IgM at 60 μ g/ml to give equimolar stimulation for 2 min at 37°C. At the end of stimulation, 10 ml of ice-cold PBS was added immediately to the samples and the cells spun down at 1500 rpm for 5 min. After removing the supernatant, 1 ml of lysis buffer was added to each sample in the presence of 1 x Complete Protease Inhibitor (Roche Diagnostics, GmbH, Mannheim, Germany) and the samples were left on ice for 30 min before the cell debris was spun down and the cleared supernatants of the lysates were transferred into new eppendorf tubes. 20 μ l lysates were left for protein determination and the rest were stored at -70 °C for later immunoprecipitation or direct western analysis.

2.8.2: BCA Protein Determination (Pierce)

A protein standard dilution series protein of 1mg/ml, 0.5mg/ml, 0.25mg/ml, 0.625mg/ml was established from a 2mg/ml Pierce BSA Standard, prepared in 96-well microtitre plate. The unknown sample dilution and lysis buffer dilution were prepared in 1 : 2; 1 : 5; and 1 : 10 if necessary. The standards and appropriately diluted unknown samples were prepared in duplicate in the sample lysis buffer or H₂O with final volume of the sample being 10 μ l. 200 μ l of "BCA working reagent" (100 μ l BCA solution B in 4.9 ml BCA solution A) was added to each well, and the plate was agitated and incubated at 37 °C for 30 min before read at A₅₉₂.

2.8.3: Immunoprecipitation and Western Blotting

At least 100 μ g of protein derived from cell lysates or 20 x 10⁶ cell lysate equivalents were subject to immunoprecipitation, in which optimal concentration of biotinylated MAb was incubated with the cell lysates for 2 hours at 4 °C, followed by Streptavidin Sepharose Beads (Amersham Pharmacia Biotech, Uppsala, Sweden) for an additional hour, or optimal concentration of polyclonal antibodies were incubated with the cell lysates overnight at 4 °C, followed by Protein G Sepharose Beads (Pharmacia/Amersham) for 2 hours. The immunoprecipitates were then washed 3

times with lysis buffer, eluted by addition of a equal volume of 2 x SDS sample buffer containing 2.5% 2-ME, and heated for 5 min at 95 °C. 40-50 µl of sample was loaded onto the appropriate percentage acrylamide gel. After SDS-PAGE separation, proteins were transferred for 2-3 hours at 4 °C to nitrocellulose membranes (Amersham Pharmacia Biotech UK Ltd, Buckinghamshire, England). The membrane was blocked either with 3% BSA for one hour at room temperature and incubated with primary antibodies overnight at 4 °C, or 1% BSA overnight at 4 °C and incubated with primary antibodies for one hour at room temperature. After extensive washing, the membrane was incubated with appropriate HRP-conjugated secondary antibodies against the primary antibodies for one hour at room temperature. The proteins of interests were visualised by addition of Chemiluminescent Substrate (Pierce, Rockford, Illinois). To verify equivalent protein loading, membranes were subsequently stripped with stripping buffer (See 2.2) for 15 min at room temperature and re-probed with appropriate antibodies. For quantitation of band intensities, non-saturating exposures were scanned by a Computing Densitometer (Molecular Dynamics).

2.9: PROTEIN AND LIPID KINASE ASSAYS

2.9.1: Lyn Kinase Assay using SOP [Src Optimal Peptide: AEEIYGEFEAKKKK (Sicilia et al., 1998)]

60 µl of Protein-A 50% sepharose slurry was added to pre-clear lysates for at least one hour, followed by overnight on a wheel at 4 °C, in which 3 µl of anti-Lyn antibody (Santa Cruz, 200 µg/ml) was added for every 100 µg of total cell lysates (in a final volume of approx 600 µl). 20 µl of protein-A sepharose (50% slurry) was added to each IP sample plus lysis buffer as background and continue rotating for 1.5 hours. Beads were washed 3 times in 1 ml of lysis buffer at 13,000 rpm for 1 min at room temperature. For triplicate measurement, 310 µl lysis buffer was added to each tube, which was then divided into 3 x 100 µl aliquots among three tubes. After spinning, the supernatant from beads were removed, leaving approximately 10 µl beads.

Kinase reaction mix/sample:

- 1 µl of SOP (from 5 mg/ml Stock)
- 0.25 µl of γ -³²P ATP
- 10 µl of Kinase Buffer (from 4 x Stock)

$$\frac{18.75 \mu\text{l of dH}_2\text{O}}{30 \mu\text{l total}}$$

30 μl of above kinase mix was added to each sample tube. After incubation at 30 °C for 7.5 min at 900 rpm in Eppendorf thermomixer in the hood, the reaction was terminated by brief centrifugation followed by spotting 20 μl of supernatant onto Whatman P81 chromatography paper (Clifton, NJ). Unincorporated [γ -³²P] ATP was eliminated by one 10-min wash and two 5-min washes in 0.4% orthophosphoric acid followed by a 5-min wash in 100% ethanol. The phosphorylated peptide bound to the paper was immersed in beta counter scintillation fluid and counted (Packard Instruments, Downers Grove, IL). Kinase assays were conducted in triplicate and activity was expressed in c.p.m. The amount of Lyn present in each assay was determined by eluting Lyn from the beads followed by SDS gel electrophoresis and Western blot analysis. Assays were normalized for Lyn content as measured by densitometry.

2.9.2: PI₃ Kinase Assay

Preparing Substrate Mix During the p85 immunoprecipitation, substrate mix for PI₃K was prepared: 15 μl of Phosphoinositide (PI) and 5 μl of Phosphatidylserine (PS) were added in an eppendorf tube, and the mix was dried under a stream of Nitrogen to remove the organic solvents used to store the above lipids (PS helps to reconstitute PI as micelles, which are required for optimal activity of the enzyme). 400 μl of Lipid Resuspension Buffer was added to the dry tube and pipetted up and down, before the mix was sonicated for 5 min to obtain good resuspension (after sonication, the mixture of lipids looked clear as compared to slightly cloudy earlier, and 50 μl of this mix was added to each reaction as the substrate).

Assembling Kinase Reaction After PI₃K was immunoprecipitated, the immunoprecipitates were washed with 3 x 1 ml of kinase reaction buffer, and the following added for kinase reaction in every IP sample:

PI ₃ Kinase IP	30 μl (see above)
Substrate	50 μl
Reaction Buffer (20 x stock)	5 μl
ATP (1 mM stock)	2 μl

γ - ³² P-ATP	1~2 μ l
DD water	~ 12 μ l
<hr/>	
Final Vol	100 μ l

Above reaction mix was incubated behind Perspex shielding at room temperature for 30 min, and then stopped by addition of 100 μ l 1 M HCl and 200 μ l of Methanol: Chloroform (1 Vol: 1 Vol). After vortexing for 10 sec, the reaction mix was centrifuge at 13,000 rpm for 30-60 sec, producing a lower aqueous phase with the labelled-lipid and a higher solvent phase with the beads for IP sandwiched in between. A yellow-tipped Gilson was used to aspirate enzyme product. 100 μ l of the enzyme products was loaded on to the TLC plate, which was coated shortly beforehand and dried in the air/fume hood. Coating Solution was poured on to the plate till it was evenly “wetted” and then decanted back into the bottle for reuse.

Separating Lipid Product by TLC TLC tank was assembled at least 2~4 hours before the experiment: 3 M blotting papers were arranged along the two sides of the tank before 200 ml of Tank Solution was poured. The tank was then capped and sealed using Vaseline/grease in the area of contact between the lid and the tank top. After the TLC plate was loaded and dry, it was immersed in the tank with the loading zone in contact with the tank solution. The tank was capped air-tight and left for 4~5 hours to allow for the upward migration of the lipid. When the solvent phase was within 1 cm of the top edge of the TLC plate, the plate was carefully removed and dried in the fume hood. The plate was finally wrapped in Clingwrap and exposed to autoradiography.

Quantifying Labelled Substrates The intensity of the radio-active phosphorous incorporated into lipid product was measured by Phosphorimager (Molecular Dynamics, Sunnyvale, CA), and represents the activity of PI₃ Kinase.

2.10: PRODUCTION OF ANTIBODY AGAINST CYTOSOLIC TAIL OF MOUSE CD19

CD19 cDNA was made out of spleen from BL6 wild type mice. Sal I and Not I Restriction Enzyme Sites were created at the two ends of the intracellular fragment of

CD19 cDNA (720bp) by PCR, which was subsequently cloned into the expression vector pGEX-4T-1 (4,900bp), and transformed into bacteria cloning host DH 10- α .

2.10.1: Checking CD19 Inserts from Bacteria

DNA extraction by QIAprep protocol 6 colonies were randomly picked up and 3 ml overnight culture from each was grown up at 37 °C in LB broth supplemented with ampicillin. After spinning down the culture twice in Eppendorf tube, 250 μ l of P1 buffer, 250 μ l of P2 buffer and 500 μ l of N3 buffer from QIAprep Kit were added. Cleared supernatants were transferred into QIAprep column in Eppendorf tube, centrifuged for 30-60 sec, and the flow-through was discarded. 0.75 ml of Buffer PE was added to wash QIAprep spin column. After discarding the flow-through, the QIAprep column was then placed in a clean 1.5-ml microfuge tube, and 50 μ l of Buffer EB (10 mM Tris-HCl, pH 8.5) was added to elute DNA.

Restriction Enzyme Digestion Following were added to an Eppendorf tube for each sample:

dH ₂ O:	6.8 μ l
10 x Buffer D	1 μ l
Sal I	0.1 μ l
Not I	0.1 μ l
DNA sample	2 μ l
	<hr/>
	10 μ l

After overnight digestion at 37 °C, the samples were run on 1% Agarose gel to check the correct bands.

CD19 Insert Sequencing by PCR Correct sequence of the CD19 insert was finally confirmed by PCR using primers specific for intracellular fragment of CD19:

CD19 I1: 5'- GAA GAG CCA GAC AGC GAG - 3'

CD19 I2: 5'- CTC ATA GCC ACT CCC ATC - 3'

For each reaction, following were added to PCR tubes:

T Reaction Mix	8 μ l
3.2 pM Primer (CD19 I1 or CD19 I2)	1 μ l
DNA Sample	<hr/> 11 μ l
	20 μ l

25 cycles of 96°C 30s, 50°C 15s, 60°C 4min was run for each reaction.

PCR products were precipitated by adding 80 µl of 75% Isopropanol, vortexing and leaving at room temperature for 15 min. After spinning down, the samples were washed again with 250 µl of 75% Isopropanol, and air-dry at 90°C for 1 min before being stored at 4 °C to be sequenced.

2.10.2: Transformation of CD19 containing vector into expression host BL-21

The vector to be transformed was diluted in 1 : 100 with H₂O, and DNA concentration was measured using the following equation:

$$\text{DNA Concentration } (\mu\text{g}/\mu\text{l}): \frac{A_{260} \text{ Reading} \times \text{Dilution factor} (100) \times 50}{1000}$$

50 ng (1-2 µl) of plasmid DNA was added into Eppendorf tube containing 200µl of competent BL-21. After leaving on ice for 30 min to let the plasmid bind to the bacteria, the Eppendorf tube was then dipped in 42 °C water bath for 1.2 min, and immediately put back into ice to stop plasmid infection. LB without Ampicillin was added into the tube and the bacteria were spread onto LB/Amp plate for overnight incubation at 37 °C.

2.10.3: Production of GST-CD19 Fusion Protein from Bacteria BL-21

Small Scale Production for Check 100 µl out of 2 ml overnight bacterial culture was taken into 2 ml of fresh LB/Amp and grown for 1.5 hours at 37°C. 100 µl of each sample was taken out as an un-induced control, before 20 µl of 10 mM IPTG was added to the rest of 1.8 ml of bacteria to induce the production of GST-fusion protein. After 4 more hours growing, 200 µl of bacteria were then taken out to be resolved by SDS-PAGE and stained with Commas Blue. Since the size of CD19 insert DNA is 700bp, the estimated protein size should be: $700/3 \times 110 = 25.6$ kD; the size of GST protein is 27 kD, the correct size of GST-CD19 fusion protein, therefore, should be: $25.6 \text{ kD} + 27 \text{ kD} = 52 \text{ kD}$.

Large Scale Production for GST Pull Down 2 ml out 4 ml overnight culture was taken into 200 ml of fresh LB/Amp to grow for additional 2.5 hours. After checking the OD at 595 nm to be 0.6, 200 µl of 0.1 M IPTG was added to the 200 ml culture (final concentration of 0.1 mM) and incubation continued for 3 hours at 37 °C before

spinning down at 3,500 rpm for 15 min at 4 °C. Bacteria pellet was resuspended in 12 ml of STE (10mM Tris, pH8.0, 150mM NaCl, 1 mM EDTA), transferred to 50 ml tubes and spun down at 2,500 rpm for 10 min 4 °C. Bacteria were lysed on ice by 12 ml of STE containing 1.5% Sarkosyl (2.2 ml from 10% stock), 5mM DTT (60 µl from 1M stock) and proteinase inhibitors. After vortexing for 5 s, cells were sonicated on ice for 1 min (power level 5, 50% duty cycle, 2 x 6 pulses) and the bacteria lysate clarified by centrifugation at 15,000 rpm for 10 min at 4 °C. Supernatant was transferred to a fresh 50 ml tube on ice and 10 ml of Triton X-100 from 10% stock in STE was added, plus 500 µl of washed and swollen glutathione beads (1:1 in PBS). The mixture was incubated overnight by rotating at 4 °C, before spinning down the beads at 2000 rpm for 10 min at 4 °C, and washing 2 more times with 40 ml of ice-cold PBS each. Pelleted beads were then transferred into an eppendorf tube and the CD19-GST was eluted by incubating with 5 x 400 µl of Elution Buffer (10mM glutathione, 50mM Tris pH 8.0, 0.1 % Triton X-100, 5 mM DTT) at 4 °C, 15 min each time before spinning down at 2,000 rpm for 2 min at 4°C. The CD19-GST fusion protein was collected from each elution into a new tube and stored at -70 °C.

2.10.4: CD19 Quantitation and Purification for Immunization

The amount of CD19 in the eluted solution was measured by titrating against a standard protein BSA in 1 µg, 5 µg, and 10 µg. After resolved by 10% SDS gel, the proteins were visualized by Commasie Blue staining and the amount of CD19 protein was compared against BSA to calculate the protein concentration of the stock.

For rabbit immunization, 200 µg of CD19 was loaded onto 10% SDS gel. After electrophoresis, the gel was stained in a solution of 4M Sodium Acetate for 20 min on a shaker at low speed. The stained band was viewed by looking at the gel against a black non-reflective surface. A band of 52 kD was cut out and rinsed in 3-4 changes of 50 ml dH₂O, minced in a small volume of PBS in an Eppendorf tube and stored at -70 °C until being injected into rabbits.

2.11: CELL PROLIFERATION ASSAY

2.11.1: CFSE Labelling

10×10^6 purified primary B cells were washed with RPMI without FCS, spun down and resuspended in 1 ml of pre-warmed RPMI. 5 μ M final concentration of CFSE [5, and 6 Carboxyfluorescein diacetate succinimidyl ester] (Molecular Probes, Oregon), was added into the resuspended cells (1:10 dilution of the stock before adding 10 μ l into 1ml of cell suspension to give final dilution of 1:1000). After cells were stained at 37°C for 10 min, the excess dye was washed out with RPMI/FCS. The CFSE labelled cells were re-suspended at 2×10^6 /ml to be added 100 μ l /well into 96 well flat bottom plate containing 100 μ l of stimulus with or without inhibitors in each well.

2.11.2: Tissue Culture

200 μ l of CFSE labelled cells, plus stimulus/inhibitors in each well, were incubated at 37°C 10% CO₂ for 48 hours before FACS staining for fluorescence intensity.

2.11.3: Cell Division Measurement by FACS

After 48 hours culture, B cells were transferred into round bottom 96 well ELISA plate, spun down, and re-suspended in 200 μ l of PBS, containing 1% FCS/(1 μ g/ml) PI. The intensity of FITC labelled dye was determined by FACScan, with unstimulated (undivided) sample as a zero division control. Half of the intensity represents first division, and half of that intensity represents the second division, and so on.

2.12: CALCIUM FLUX

After purification, 10×10^6 primary B cells were collected and resuspended in Calcium Buffer (KDS-BSS + 0.1% Glucose/0.1% FCS) at room temperature. 2 μ l of 1 mM Indo-AM Cell Permeant Stock (50 μ l DMSO was added freshly into 50 μ g desiccated powder, Molecular Probes) was added into the 1 ml cell suspension to give a final concentration of 2 μ M. After vortexing, cells were covered with foil and placed at 37 °C for 40 min, with hand-mixing every 10 min. Cells were left at room temperature for 5 mins before 4 ml of Calcium Buffer was added and then left at room temperature for another 20 mins. After centrifugation, the cells were resuspended in 500 μ l of Calcium Buffer and stained for B cell with fluorochrome labelled antibody specific for B220 at room temperature for 10 min. If necessary, cells were split into two part in equal amount and treated with and without inhibitors

at 37 °C before being washed and resuspended in 250 µl of Calcium Buffer. 50 µl (1×10^6) of the cells per stimulation were transferred into FACS tubes containing 500 µl of Calcium Buffer, and each tube run for 30-45 seconds to establish a baseline. BCR crosslinking was initiated by adding 475 µl of the cells to 25 µl of 20 x anti-IgM and collecting the events for 5 min.

2.13: ELISA ASSAY

The isotypes of mouse anti-phospho (active) Src PTK antibody was measured by ELISA. Sheep anti-mouse total Ig (Silenus Laboratories) was absorbed to flexible U-bottom 96 well plates (Costar, Cambridge, MA) at 2 µg/ml in 0.2 M carbonate buffer (pH 9.5) by incubating at 37 °C for two hours. After washing the plate three times in the order of PBS containing 0.1% Tween-20, PBS, and distilled water, the tested sample was diluted at 1:10 (2 µg/ml) in the blocking solution, along with different purified mouse mAb as controls and added at 50 µl/well. The plate was incubated overnight at room temperature and then washed three times as before. Horseradish peroxidase conjugated secondary antibodies directed against different mouse isotypes (Southern Biotechnology Associates, Inc) were diluted at 1:500 in the blocking solution, and 50 µl was added into each well. After 4 hours incubation at room temperature and three washes, HRPO was detected by the addition of 100 µl of the enzyme substrate 2,2'-azinocis 3-ethylbenzthiazoline sulphonic acid (Sigma) at 0.55 mg/ml in 0.1M sodium citrate (pH 4.5) plus 0.1% H₂O₂. Absorbance was read using Titerteck Multiskan MCC/340 (Labsystems, Helsinki) at 414nm with a reference wavelength of 492nm after 30-45 min incubation at room temperature.

CHAPTER 3: THE ROLE OF LYN IN CD19 MEMBRANE LOCALIZATION

3.1: INTRODUCTION

Signalling activation through the BCR plays a critical role in the whole life cycle of B-lymphocytes. Depending on the maturation status of the B cells and the signals supplied by other cells such as T cells and macrophages, antigen binding to the BCR can lead to either elimination in the case of auto-reactive B cells or proliferation and differentiation of those B cells that recognize foreign antigens (Goodnow *et al*, 1995; Rajewsky *et al*, 1996). These events are primarily initiated by activation of Protein Tyrosine Kinases (PTKs) of the Src-family (Lyn, Fyn, Blk, Fly etc) (Burkhard *et al*, 1991); the Syk/ZAP-70 family (Syk) (Hutcheroft *et al*, 1992); and the Tec family (Btk) (Aoki *et al*, 1994). The phosphorylation of multiple substrates by these kinases leads to the activation of multiple intracellular signal pathways including phosphoinositide hydrolysis, the Ras pathway and intracellular calcium elevation. These culminate in the activation of a series of DNA binding proteins that initiate specific gene transcription for cell proliferation and differentiation.

A well-balanced BCR signal, however, requires further regulation and this is provided by a series of surface molecules that modify and provide a context for signal transduction. For example, CD22 can negatively regulate BCR signals via recruiting the phosphotyrosine phosphatase, SHP-1, to the Immunoreceptor Tyrosine-based Inhibitor Motifs (ITIM) of its cytoplasmic tail. After phosphorylation SHP-1 can down-regulate BCR signalling by dephosphorylation of Src PTK, Syk (Siminivitch *et al* 2000; Dustin *et al.*, 1999), as well as the adaptor protein BLNK/SLP65 (Mizuno *et al.*, 2000). The low affinity Fc γ Receptor IIB on the B cell also has an ITIM in its cytoplasmic tail, but the major phosphatase it recruits after phosphorylation is SH2-containing Inositol Phosphatase (SHIP), which inhibits the Ras pathway through binding to P62^{dok} and competing for Shc (Tamir *et al*, 2000). CD19, on the other hand, can promote BCR signals by providing docking sites in its phosphorylated cytoplasmic domain for additional signalling molecules such as PI3-Kinase and Vav (Tuveson *et al*, 1993; Weng *et al*, 1994). By binding to CD19, these intracellular

signalling molecules are brought in close proximity to the plasma membrane, where their upstream activators are located.

As a Src PTK family member, Lyn was originally thought to be the amplifier of BCR signaling, which was supported by the fact that it can phosphorylate tyrosine(s) in the ITAMs of the Ig α / Ig β subunits of BCR complexes (Songyang et al., 1995; Schmitz et al., 1996), and lead to the activation of Syk (Kurosaki et al., 1994; Rowley et al., 1995; Kimura et al., 1996), an essential enzyme for B cell signalling cascades. Later on, however, the generation of *lyn*^{-/-} mice demonstrated that Lyn was mainly involved in the negative regulation of BCR signaling, because the primary B cells from these mutant mice were hyper-responsive to BCR crosslinking (Wang et al., 1996; Chan et al., 1997; Chan et al., 1998; Cornall et al., 1998). Indeed, Lyn was found to be required to phosphorylate ITIMs of some negative BCR co-receptors such as CD22, Fc γ RIIB, CD72 and PIR-B (Smith *et al*, 1998; Nishizumi *et al*, 1998; Maeda et al., 1999); some negative intracellular molecules such as rasGAP-associated docking protein p62^{dok} (Yamanashi et al, 1999); and phospho-tyrosine phosphatases, such as SHP-1/2 (Harder et al, 2001). Given the diverse substrates that Lyn could have worked on, there are still a lot of unknown mechanisms associated with this unique Src protein tyrosine kinase. For instance, when Lyn loss-of-function mice tend to have autoimmune disease, the Lyn-gain-of-function mice also end up with autoimmunity (Hibbs et al., 2002). The paradoxical effects of Lyn prompt us to search for novel substrates to explain the complex role of Lyn in BCR signaling.

CD19 is an important BCR co-receptor, which can lower the threshold for the number of BCR that must be ligated to activate the B cell when antigen is limiting. What is more, CD19 might also allow the BCR to engage signalling pathways that would not otherwise be effectively activated, because cross-linking CD19 with BCR has been reported to result in enhanced cell proliferation (Carter *et al*, 1992); augmented MAPK activation (Tooze *et al*, 1997); elevation of calcium flux (Carter *et al*, 1998); up-regulating B7-1 and B7-2 expression (Kozono et al, 1998); and retention of BCR in the lipid raft of plasma membrane for signalling (Cherukuri *et al*, 2001). The positive role of CD19 was further supported by the recent finding that CD19 can also exert a role before antigen encounter by promoting the survival of naïve recirculating

B cells (Otero et al., 2003). Consistent with these in vitro findings, CD19^{-/-} mice demonstrate an immuno-deficient phenotype, while genetically modified mice that over-express CD19 developed autoimmunity (Sato et al., 2000).

Since the tight regulation of CD19 function is likely to be a critical event for normal immunity, and its expression was believed to possibly modulate the activities of Src-PTK Lyn, CD22, SHP-1, and FcRII (Fujimoto et al., 1999; Fujimoto et al., 2000; Tedder et al., 2000), the molecular interaction between Lyn and CD19 were thoroughly investigated in chapter 3 and chapter 4 of this thesis, with Chapter 3 focusing on the physical association, and chapter 4 focusing on biochemical interaction between these two molecules.

3.2: RESULTS AND DISCUSSION

3.2.1: Lyn is dispensable for activating BCR signalling.

The most rapid biochemical changes induced by antigen binding to the B cell Receptor (BCR) is tyrosine phosphorylation of a multitude of molecules inside the B lymphocyte. Since Src family protein tyrosine kinases are among the first to be activated following BCR stimulation (Saouaf et al., 1994), and the ITAMs of Ig α / β complex match Src-family kinase specificities (Songyang et al, 1995; Schmitz et al., 1996), Src family PTKs are thought to be the initiator of BCR signalling. The role of Lyn, a member of Src family PTKs, in relaying the phosphorylation signal induced by BCR crosslinking was therefore examined in a B cell line, in which immature primary B cells from both wild-type and Lyn-deficient mice was immortalized by transformation with an E μ -myc transgene (Corcoran et al., 1999). BCR stimulation was achieved by adding F(ab')₂ portions of goat anti-mouse IgM to avoid the engagement of Fc receptors on the B cells. In the control cell line, BCR crosslinking induced rapid tyrosine phosphorylation of numerous intracellular molecules at 1 minute time point compared with the 0 minutes unstimulated sample. This BCR-induced tyrosine phosphorylation of signalling molecules peaked at 5 minutes and has receded substantially by 25 minutes post-stimulation. In the Lyn-deficient B cell line, however, the kinetics of tyrosine phosphorylation of signalling molecules is different from that of wild type cell line. Within the first five minutes after stimulation, the total protein phosphorylation of Lyn-deficient B cells was weaker than that of control, indicating a delay in relaying BCR signalling in absence of Lyn. 25 minutes later, however, the phosphorylation inside Lyn-deficient B cells eventually reached a maximum, close to the 5 minutes peak level of wild type cell line (Fig 3.1). This result demonstrates an important role of Lyn in initiating BCR signalling, but its role in activating B cells is redundant. In Lyn's absence, BCR signalling activation can still be accomplished although decreased for the first few minutes.

3.2.2: Lyn has a weak association with CD19, a positive modulator of BCR-

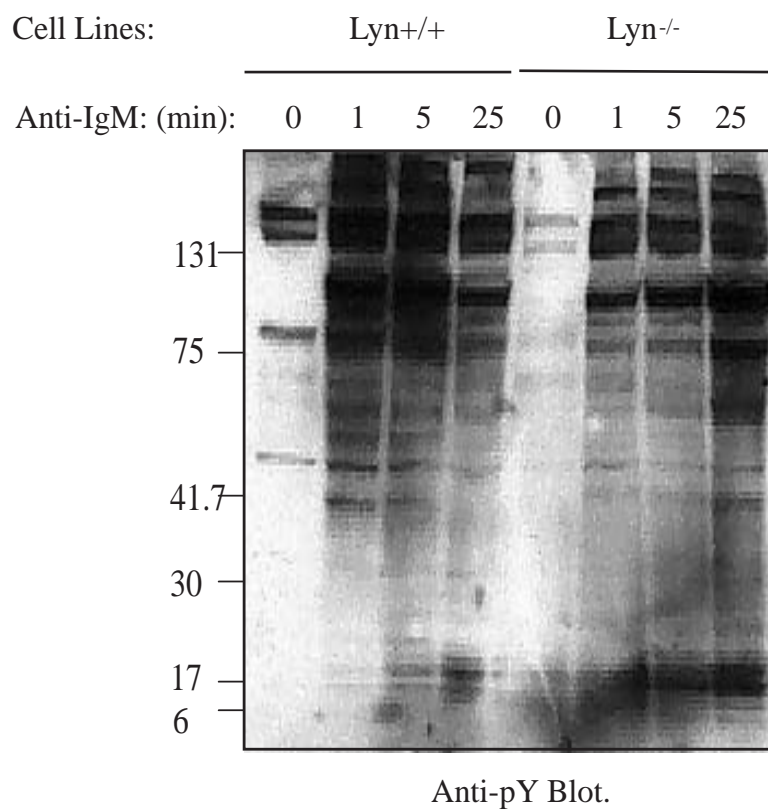

Figure 3.1: Signal activation through BCR is delayed but still accomplished in absence of Lyn. Equal number of cells (2×10^6) from both wild type (Lyn^{+/+}) and Lyn-deficient (Lyn^{-/-}) B cell lines were stimulated with the F(ab')₂ portion of goat anti-IgM at 37 °C for different time period as indicated and then lysed. The total cellular proteins were separated by SDS-PAGE, and subjected to anti-phosphotyrosine Western blotting. Shown on the left are the standard protein marker in kD.

induced MAP kinase activation.

The dispensable role of Lyn in BCR signal activation prompted us to investigate its role in promoting signalling through BCR co-receptors. CD19 is an important BCR co-stimulatory molecule that functions in conjunction with the BCR to amplify signal transduction (Carter and Fearon, 1992). The major means by which CD19 is thought to couple extracellular ligation to intracellular signalling pathways is by the tyrosine phosphorylation of its large 242 amino acid cytoplasmic domain (Sato et al., 1997). Therefore, the kinetics of wild-type CD19 phosphorylation in response to BCR stimulation was first examined before checking the role of Lyn in CD19 signalling. CD19 was immunoprecipitated by biotinylated rat anti-CD19 monoclonal antibody (see table 2.1). The specificity of CD19 precipitation and subsequent western detection were confirmed by comparing biotinylated rat mAb anti-CD19 immunoprecipitation in both wild type and CD19-deficient primary B cells, with the isotype matched biotinylated rat mAb anti-B220 immunoprecipitation in wild type primary B cells as isotype control (Fig 3.2A). After stimulating B cells for varying times, CD19 was immunoprecipitated and its tyrosine phosphorylation checked by anti-phosphotyrosine mAb (4G10). The filters were then stripped and probed for CD19 to confirm the identity of the precipitated proteins. In our Lyn^{+/+} B cell line, CD19 was rapidly tyrosine phosphorylated at 1 min point post-BCR stimulation. After 5 minutes, CD19 phosphorylation began to decline, but was still detectable 15 minutes after BCR cross-linking (Fig 3.2B). The profile of CD19 phosphorylation in primary B cells is similar to that of B cell lines, with a peak at the 1 minute time point, a decline at 5 minutes, yet still visible at 15 minutes post-stimulation (Fig 3.2C).

The rapid tyrosine phosphorylation of CD19 after BCR crosslinking should correlate with a positive role in BCR pathway. One of the important effectors of BCR signalling is the Erk MAP kinase that once activated, is rapidly translocated into the nucleus to initiate the transcription of some early response genes. Thus the effect of CD19 on Erk MAP kinase activation was titrated against increasing concentration of anti-CD19 antibody either alone or together with anti-Ig κ . The MAP kinase activation

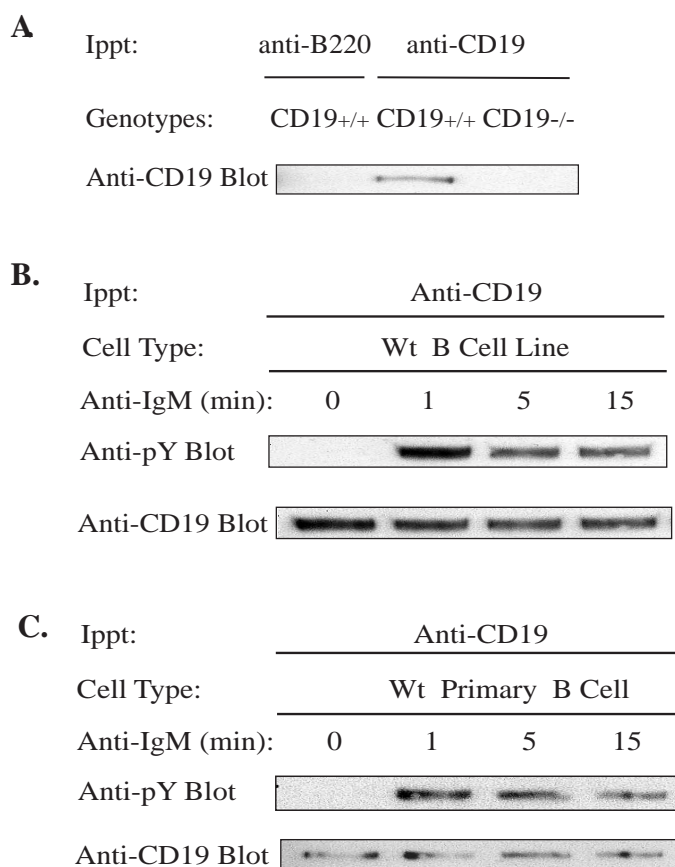

Figure 3.2: CD19 is rapidly tyrosine phosphorylated after BCR ligation: The specificity of CD19 immunoprecipitation is shown in (A), in which anti-B220 antibody, as isotype control, failed to immunoprecipitate CD19, while anti-CD19 antibody immunoprecipitated CD19 from CD19-sufficient mice but not from CD19-deficient mice. B cell line (B) or primary B cells (C) were stimulated with the F(ab')₂ portion of anti-IgM for the indicated time period before being lysed and CD19 immunoprecipitated for anti-phosphotyrosine blotting. The filters were stripped and reprobbed with anti-CD19 for loading control.

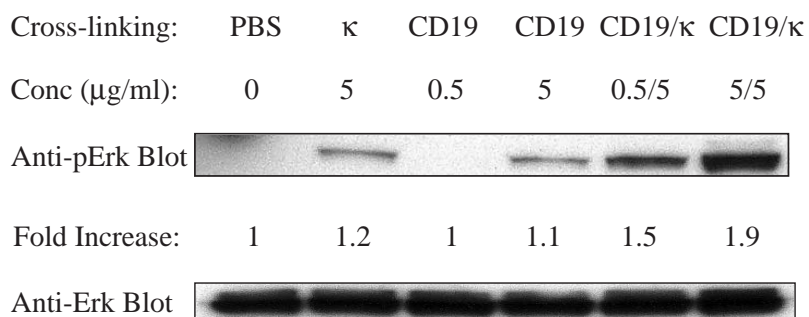

Figure 3.3: CD19 positively regulates Erk activation. Purified splenic B cells from wild type mice were pre-incubated with either medium, biotinylated anti-Ig κ , biotinylated anti-CD19 or both antibodies at the indicated concentrations. B cell stimulation was initiated by addition of avidin and halted after 2 min. Whole cell lysates were probed with antibodies specific for the phosphorylated form of Erk (upper panel). Membranes were stripped and re-blotted with anti-Erk to reveal protein loading (lower panel).

was checked by Western blotting with antibody that recognizes the phosphorylated (activated) form of Erk. Erk MAP kinase phosphorylation/activation occurred

following ligation of either membrane Ig κ or CD19 alone at 5 μ g/ml, but the activation signal of the MAP kinase is much stronger when membrane Ig and CD19 were co-ligated than when either was crosslinked alone (Fig 3.3). This may indicate that the function of CD19 requires BCR crosslinking, and the tyrosine kinase(s) that act(s) on CD19 to initiate its function are most effectively activated by membrane Ig.

Since Src family PTKs are the first to be activated by membrane Ig (Saouaf et al., 1994), and Lyn is the predominant Src PTK in B cells (Burkhardt et al., 1991), the physical association of Lyn with CD19 in response to BCR ligation was checked to test the possibility that Lyn acts on CD19. After stimulation with anti-IgM, B cells were lysed with detergent and CD19 immuno-precipitated. The immunoprecipitates were separated on SDS gel, transferred onto membrane and probed for the presence of Lyn. The physical association of Lyn with CD19 was not detected until a lower concentration of detergent (0.5% Triton X100) was used to lyse the cells (Fig. 3.4). After BCR-crosslinking for 5 min, a tyrosine phosphorylated band of 95 kD was visible. Below this 95 kD band were two weak tyrosine phosphorylated bands of 56 kD in both unstimulated and stimulated lanes. Stripping and probing the filter with anti-CD19 and anti-Lyn Abs proved these bands to be CD19 and Lyn respectively (the blot on the right is the isotype control and total cell lysate (TCL) result of Lyn migration position on the gel under the same system condition). The weak association of Lyn with CD19 is constitutive. BCR-induced CD19 phosphorylation, however, did not increase the amount of Lyn binding processively to CD19. Nevertheless, the constitutive association of Lyn with CD19 makes it possible that Lyn initiates the tyrosine phosphorylation of CD19 after BCR cross-linking.

3.2.3: CD19 failed to be solubilized by non-ionic detergent in Lyn-deficient primary B cells.

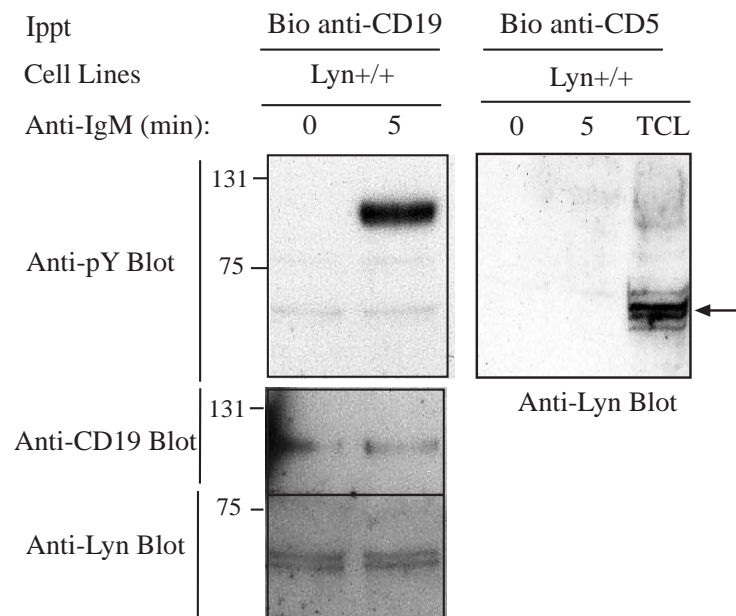
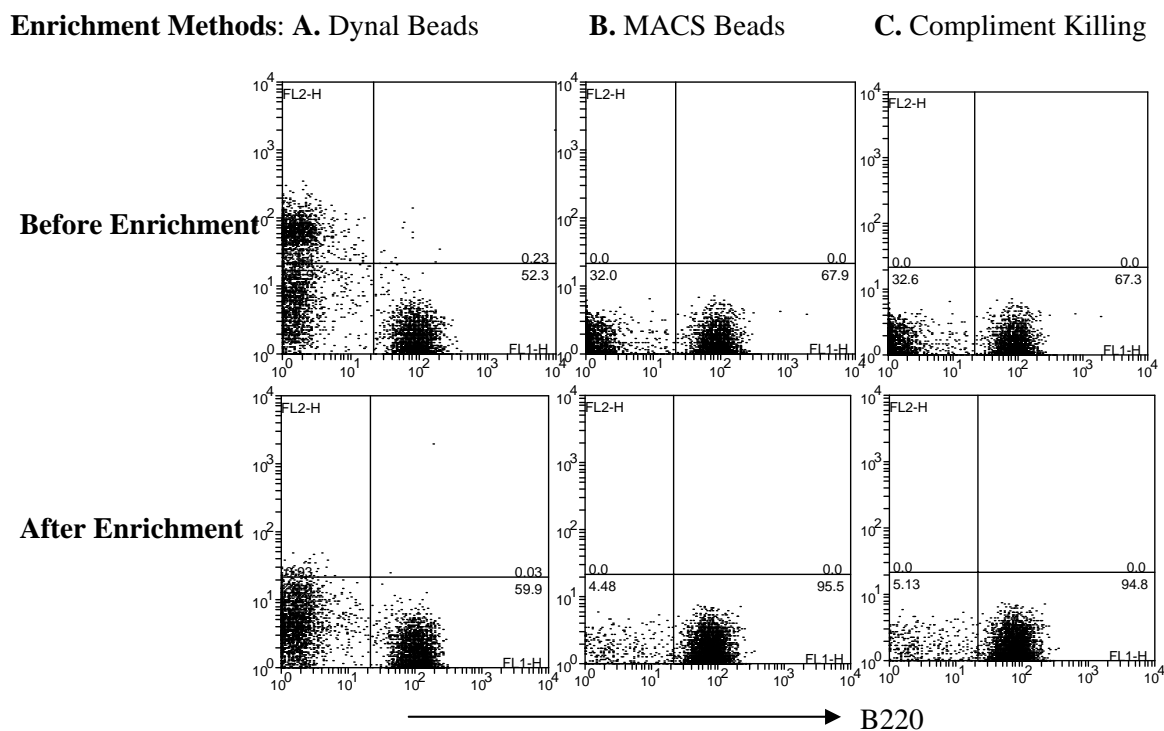

Figure 3.4: Lyn is weakly associated with CD19. CD19 was immunoprecipitated from a Lyn^{+/+} B cell line after the indicated time of stimulation and the Western blot was probed sequentially for phosphotyrosine (upper left panel), CD19 (middle left panel), and Lyn (lower left panel). A control Ab (Bio-anti-CD5) failed to precipitate Lyn from the Lyn^{+/+} B cell line, either unstimulated or stimulated (upper right panel). Lyn was detectable in the total cell lysate (TCL) and indicated by the arrow.

After detecting the weak association of Lyn with CD19, we next want to know whether Lyn is required for CD19 phosphorylation. To this end, CD19 need to be immunoprecipitated from both wild type and Lyn-deficient primary splenic B cells. Unlike cell lines, spleens contain an array of different cell lineages including B cells, T cells, and macrophages and therefore enrichment was done for B cells. A number of ways have been tried for negative depletion of non-B cells amongst the splenocytes, which included using Dynal beads coated with anti-CD43; MACS Beads coated with anti-rat mAb after incubating samples with cocktails of rat anti-T cell Abs and finally complement killing of T cells. Among these three methods of eliminating non-B cells, MACS beads give the highest B cell purity (95.5%), but the recovery is the lowest (8.16×10^6 /spleen). Therefore, compliment depletion of T cells was used to enrich B cells in mouse spleen because of its high recovery and B cell purity (Fig 3.5).

We enriched B cells from Lyn-deficient and wild-type control spleens by complement killing of T cells. The percentage of B cell population enriched was lower from Lyn-deficient spleen than from wild-type control (around 50% compared to 95%) due to a higher proportion of granulocytes and macrophages in the spleens from Lyn-deficient mice (Hibbs et al., 1995; Nishizumi et al., 1995). We thought, however, that this shouldn't affect our examination of CD19 phosphorylation in response to BCR stimulation as long as we adjusted the number of B cells in each sample to be the same since CD19 is only expressed in B cells and the stimulus added was also B cell specific. After cross-linking the BCR with the F(ab')₂ portion of goat anti-IgM, purified splenic B cells from both wild-type and Lyn-deficient mice were lysed with normal detergent (1% Triton X100), CD19 immunoprecipitated and transferred onto nitrocellulose membrane. To our surprise, probing the filter with rabbit anti-CD19 serum failed to reveal CD19 in the Lyn-deficient sample while it did in the wild type samples (Fig 3.6A). To check the availability of CD19 for immunoprecipitation in the absence of Lyn, the splenic B cells from wild-type and Lyn-deficient mice were stained for surface CD19 expression. Although the number of splenic B cells in the Lyn-deficient mice are somewhat lower than that of wild type control, CD19 expression, on a single cell basis, is the same (Fig 3.6B).



Splenocyte Input:	67×10^6	64×10^6	82×10^6
Splenocyte Output:	26×10^6	8.16×10^6	32.8×10^6

Figure 3.5: Comparison of different B cell enrichment methods. Splenocytes from one wild-type mouse spleen were either incubated with Dynal beads coated with anti-CD43 Ab (A), or incubated with a cocktails of rat anti-T cell Abs before addition of MACS beads coated with anti-rat Ab (B), or anti-T cell Abs plus compliment (C). After depletion of non-B cells, samples were stained for B220 to check B cell purity, except in the sample enriched by Dynal beads, additional CD43 staining was also scanned in FL2 channel to check the efficiency of depletion.

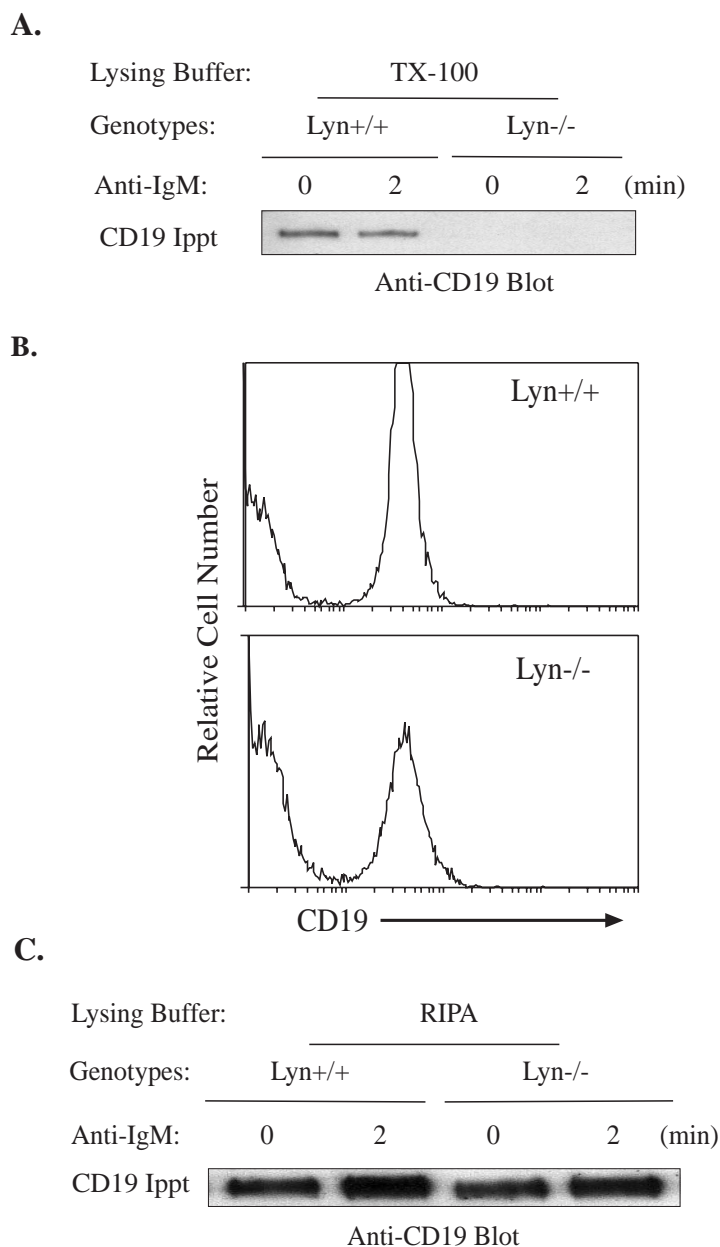

Figure 3.6: CD19 solubilization by different lysis buffer. Purified splenic B cells (20×10^6 /time point) were stimulated with the $F(ab')_2$ anti-IgM for the indicated times, and lysed with different lysing buffers as indicated (A and C). Immunoprecipitated proteins were transferred to a filter and probed with rabbit polyclonal anti-CD19 antibody. Splenocytes from both wild type and Lyn-deficient mice were enriched for B cells by complement depletion of T cells. CD19 expression on $lyn^{+/+}$ and $lyn^{-/-}$ splenocytes displayed using FACS histogram (B).

Since CD19 expression is not down-regulated in Lyn-deficient primary B cells, the failure to recover CD19 from a Triton X100 lysate may be due to the weakness of this detergent. Therefore RIPA buffer was tried, as this contains 0.1% SDS in addition to 1% TX100 and 1% Deoxycholate. After lysing the Lyn-deficient primary B cell in RIPA, CD19 was successfully detected on the filter, in equivalent amounts to wild-type mice (Fig 3.6C)

The fact that the non-ionic detergent Triton X-100 did not extract CD19 from the B cell membrane from Lyn-deficient mice while a stronger SDS detergent did lead us to hypothesise that in the absence of Lyn, CD19 might be constitutively located in a Triton X-100-insoluble micro-domain on cell membrane called lipid raft and this may contribute to the hyper-responsiveness of Lyn-deficient B cells.

3.2.4: Lipid rafts are signalling platforms, but do not constitutively contain CD19 in the absence of Lyn

For a long time, lipids were thought to play only a passive role as simple building blocks for membranes that delimit intracellular compartments and separate the internal milieu from the extracellular environment. In the fluid mosaic model, cellular membranes were envisaged as disordered uniform bilayers in which lipids moved freely and randomly by lateral diffusion (Levine et al., 1971). During the past decade, a new model that accounts for lipid diversity emerged. This model proposed the existence in biological membranes of lipid microdomains or rafts that have a high sphingolipid and cholesterol content (Simons and Ikonen, 1997). Unlike the loosely packed, disordered phospholipids present in the bulk of membranes, raft lipids are organised in a tightly packed, liquid-ordered manner, and have been proposed to function as platforms for both signal transduction and membrane trafficking (Simons and Ikonen, 1997).

The tight packing of lipids in rafts confers resistance to solubilization by non-ionic detergents at low temperatures, which allows their isolation as an insoluble membrane fraction according to their buoyant density on sucrose gradients (Brown and Rose, 1992; Parton et al., 1995; Rodgers et al., 1996). Several important signalling proteins have been identified as residents of these lipid microdomains, including double-

acylated Src family protein tyrosine kinases (Casey et al., 1995) and Zap-70 family protein tyrosine kinase (Stauffer et al., 1997), but not the phosphatase CD45 (Cheng et al., 1999). Lipid rafts also contain cholesterol and glycosphingolipid (GM1 ganglioside), which can be detected by cholera toxin B subunit (CTB) and serves as a means of identifying lipid rafts.

In order to check whether CD19 is constitutively located in this signalling microdomain in Lyn-deficient B cells, we first needed to isolate and characterize lipid rafts from cell membranes. Our initial attempt to isolate the lipid raft in primary B cells was unsuccessful due to the difficulty in obtaining the necessary amount of purified splenic B cells (10^8) from Lyn-deficient mice. We therefore turned to our *lyn*^{-/-} and *lyn*^{+/+} B cell lines, in which the B cells are immortalised at immature stages. After lysing the cells in Triton X-100 buffer on ice, lipid rafts were floated on discontinuous sucrose gradients by high-speed centrifugation, and 1 ml fractions were collected from the top to the bottom of the gradients, of which 20 μ l aliquots were subjected to SDS-PAGE separation (see materials and methods for details). The fractions at the top (3/4) represent lipid raft and those at bottom (11/12) represent domains outside lipid raft as defined by revealing the raft specific substances cholesterol and glycosphingolipid (GM1 ganglioside) and Lyn all in fraction 4 and CD45R in fraction 10, 11, and 12 in Western blot (Fig 3.7).

As a signalling platform, lipid raft domains should maintain a dynamic exchange of proteins that are important for antigen receptor signalling before and after stimulation. To verify this dynamics, lipid rafts from the surface IgM-expressing B cell line were isolated before and after BCR cross-linking, transferred onto filters, and revealed by western antibody. A great amount of IgM was identified outside lipid rafts in fraction 10, 11, and 12 despite the antigen receptor stimulation (Fig 3.8A). This IgM comprised both surface IgM and the cytoplasmic IgM in and outside ER. A small proportion of surface IgM was found in lipid rafts of plasma membrane before receptor stimulation. After receptor stimulation, however, the proportion of sIgM in

CHAPTER 4. INDEPENDENT REGULATORY ROLES OF LYN AND CD19

4.1: SUMMARY:

The balance between immunity and tolerance depends on the appropriate balance between positive and negative signals within lymphocytes. Key mediators of signalling in B cells include the cell surface glycoprotein CD19 and the Src-related protein tyrosine kinase Lyn. A recent model of the biochemical events following B cell receptor (BCR) ligation intimately links the activation of Lyn and CD19 despite the unique regulatory functions of CD19 and Lyn being thought to be in opposition to each other. We examined the biochemical consequences of BCR ligation in mouse B cells deficient in either Lyn or CD19 for evidence of interaction or co-dependence. In contrast to published results we found that the extent of CD19 phosphorylation following BCR ligation was unaffected by the absence of Lyn yet was dependent on other Src-family PTKs as it was inhibited fully by pp2, a Src-family specific inhibitor. Consistent with the normal phosphorylation of CD19 in *lyn*^{-/-} B cells, the recruitment of phosphoinositide-3 kinase to CD19 and the ability of CD19 to enhance both intracellular calcium flux and Erk1/2 activation after co-ligation with the BCR were intact in the absence of Lyn. Similarly, unique functions of Lyn were found to be independent of CD19. The increase in Lyn kinase activity following BCR ligation and the inhibition of BCR-mediated calcium flux by CD22 and Erk MAP kinase activation by FcγRIIB were all normal in CD19^{-/-} B cells. Collectively, these data argue that the unique functions of Lyn do not require CD19 and that the signal amplification mediated by CD19 is independent of Lyn. We conclude that the roles of Lyn and CD19 following BCR ligation are independent and opposing, one being primarily inhibitory and the other stimulatory.

4.2: INTRODUCTION:

The developmental fate of B lymphocytes is determined largely by signals emanating from the B cell receptor (BCR). Early in development, productive rearrangements at the Ig heavy and light chain loci are required for pre-B cells to reach the immature B cell stage. Entry of immature B cells into the population of mature recirculating B lymphocytes requires the cells to successfully negotiate BCR-mediated negative

selection for high avidity self-reactivity (Hartley et al., 1991; Nemazee & Burki, 1989) as well as a BCR-mediated positive selection step (Gu et al., 1991; Loder et al., 1999). Persistence of mature B cells is dependent similarly on the presence of a functional BCR (Lam et al., 1997). B cell involvement in immune responses to exogenous antigens requires the avidity of the interaction between the BCR and the antigen to be greater than a certain threshold value. Signalling through the BCR thus determines both the survival and the reactivity of B cells.

It is also clear, however, that the cellular and molecular environment in which BCR ligation occurs can modulate the outcome. T cells, for example, can enhance B cell activation by providing membrane bound and secreted co-stimuli such as CD40-ligand and cytokines (Baxter & Hodgkin, 2002). Similarly, components of the complement cascade such as C3d fragments bound to an antigen can greatly increase the B cell response by co-ligating the complex comprising CD21, CD19 and Leu-18 with the BCR (Carter & Fearon, 1992; Dempsey et al., 1996). Conversely, co-ligation of Fc γ RIIB1 with the BCR via the Fc regions of Ig bound to antigen can inhibit B cell reactivity (Malbec et al., 1999). That is, receptors on the surface of the B cell that sense the context in which BCR engagement occurs can positively and negatively modulate the signal delivered through the BCR and thus may be critical in determining the outcome, be that activation, differentiation or death.

The molecular pathways emanating from the BCR and its accessory molecules are becoming increasingly well defined. BCR cross-linking results in the rapid activation of Src-related protein tyrosine kinases, of which Lyn is predominant in mouse B cells. Active Src-PTKs facilitate the phosphorylation and consequent activation of Syk, the dominant PTK in B lymphocytes. The positive role of Lyn in Syk activation in mouse B cells does not appear to be unique since in the absence of Lyn, Syk activation occurs, albeit at a reduced rate (Chan et al., 1997; Cornall et al., 1998). Active Syk efficiently phosphorylates numerous intracellular substrates mediating B cell activation including Ig α , Ig β and various adaptor proteins including BLNK (SLP-65/BASH) and phospholipase C β (PLC β) (Marshall et al., 2000). These molecules in turn mediate a cascade of events resulting in release of Ca²⁺ from intra-cellular stores, activation and nuclear localization of NF-AT and NF κ B and, if the conditions

are correct, mitogenesis. CD19 exerts its positive effect on BCR signalling by the phosphorylation dependent recruitment of Vav and phosphatidylinositol-3 kinase (PI3K), that in turn enhances Ca flux, activation of the extracellular signal-regulated kinase (ERK1/2) and, ultimately, B cell proliferation (Carter & Fearon, 1992; Carter et al., 1988; Tooze et al., 1997). CD19 deficiency results in a hypo-responsive B cell phenotype in which activation mediated by BCR cross-linking and T cell dependent immune responses are compromised to varying degrees (Engel et al., 1995; Rickert et al., 1995).

Ligation of the BCR also initiates negative regulatory cascades that often involve the recruitment of phosphatases to BCR-proximal molecules. For example, co-ligation of CD22 with the BCR results in it being phosphorylated on tyrosines contained within immunoreceptor tyrosine-based inhibitory motifs (ITIMs) that serve as binding sites for the SH2 domains of the phosphatase SHP-1 (Doody et al., 1995). SHP-1 is active in dephosphorylating many of the signal transduction molecules proximal to the BCR such as Syk, BLNK and Ig α (Adachi et al., 2001). Phosphorylation of tyrosines within the ITIM of several B cell negative regulatory molecules such as CD22, CD72 and PIR-B has been found to depend on Lyn (Adachi et al., 1998; Chan et al., 1998; Cornall et al., 1998; Ho et al., 1999; Nishizumi et al., 1998; Smith et al., 1998). Loss of these molecules results in a hyper-responsive B cell phenotype and autoimmunity (Nitschke et al., 1997; Pan et al., 1999; Ujike et al., 2002), as is also the case for loss of Lyn (Chan et al., 1997; Hibbs et al., 1995; Wang et al., 1996), although the phenotypes are not identical. Thus biochemical and cellular studies have defined unique roles for Lyn in inhibiting BCR signalling. The role of Lyn in promoting BCR signalling through phosphorylation of immunoreceptor tyrosine based activation motifs (ITAM) in Ig α / β does not appear to be unique (Chan et al., 1997; Takata et al., 1994), presumably due to the activity of other Src-related PTK in B cells such as Fyn and Blk.

Given that most experimental data have defined almost diametrically opposing functions for CD19 and Lyn in regulating B cell activation, two recent observations came as somewhat of a surprise. These findings were that 1) the initial phosphorylation of CD19 was entirely dependent on Lyn (Fujimoto et al., 2000a) and

2) increased Lyn activity in stimulated B cells was dependent on the presence of an amplification loop centered on tyrosine phosphorylation of CD19 (Fujimoto et al., 2000a; Fujimoto et al., 1999b). Given this proposed inter-relationship between Lyn and CD19 in B cell activation, we endeavoured to more clearly define the molecular basis and consequences of this interaction. We have re-examined the relationship between CD19 and Lyn and found that the pathways in which these two molecules participate in an obligatory manner are essentially independent of each other.

4.3: RESULTS

4.3.1: CD19 phosphorylation is intact in Lyn-deficient B cells

It has been reported that tyrosine phosphorylation of CD19 is compromised in Lyn-deficient B cells following BCR ligation (Fujimoto et al., 2000a). To confirm this observation, we checked CD19 tyrosine phosphorylation first in B cell lines in which B cells from both Lyn-deficient mice and wild type controls had been immortalized at an immature state (Corcoran et al., 1999). After stimulation with F(ab')₂ polyclonal anti-IgM reagent for different times, the B cells were lysed and CD19 immunoprecipitated. The tyrosine phosphorylation of CD19 was checked by Western blot with 4G10. Contrary to published results (Fujimoto et al., 2000a), we found no difference in the level or rate of CD19 phosphorylation in *lyn*^{-/-} B cells after BCR ligation when compared to control B cells (Fig 4.1A). We also measured the tyrosine phosphorylation status of CD19 in *lyn*^{+/+} and *lyn*^{-/-} splenic B cells immediately prior to, or 1 and 5 minutes after BCR cross-linking. Similar results were obtained in the cell lines and primary B cells (Fig 4.1B). These data demonstrate clearly that the presence of Lyn is not obligatory for CD19 phosphorylation in mouse B cells.

4.3.2: CD19 is a substrate of Src- family PTK.

BCR cross-linking induces tyrosine phosphorylation of CD19 while cross-linking CD19 alone does not (Fujimoto et al., 2001; Inabe & Kurosaki, 2002). The PTK responsible for CD19 phosphorylation is presumed, therefore, to be BCR-associated with Lyn and Syk being prime candidates. Since we have shown CD19

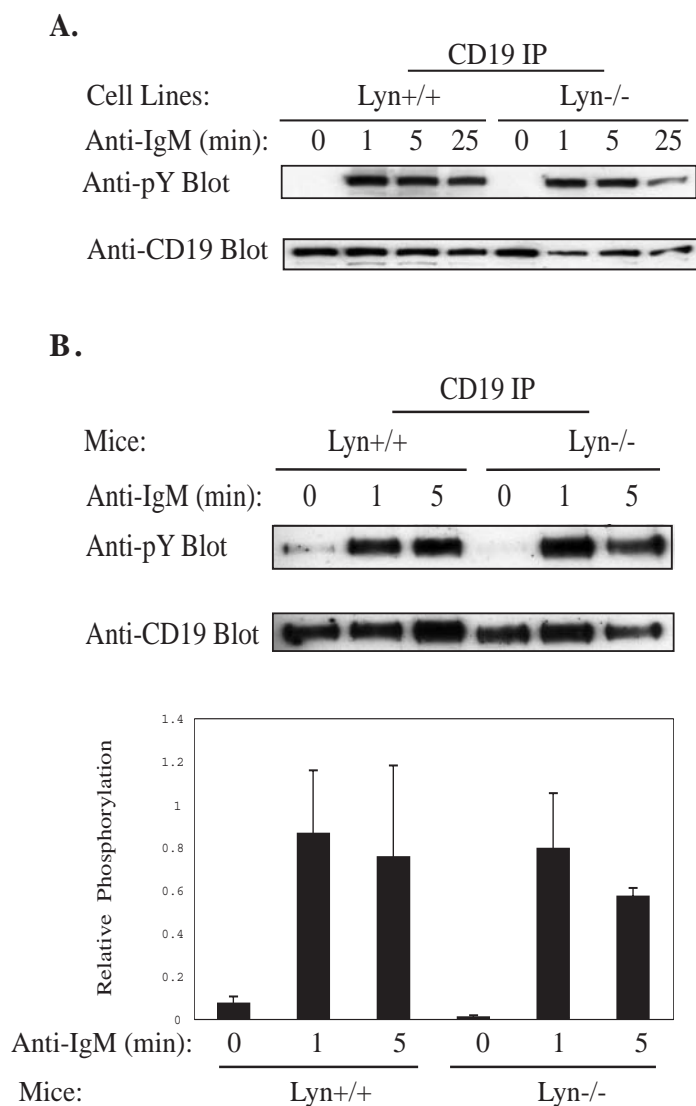

Figure 4.1. CD19 phosphorylation in the absence of Lyn. *lyn*^{+/+} and *lyn*^{-/-} B cell lines (A), or purified splenic B cells from both wild type and *lyn*^{-/-} mice (B) were stimulated with F(ab')₂ anti-IgM for the indicated times, lysed and CD19 immunoprecipitated. Immunoprecipitated proteins were probed with the anti-phosphotyrosine antibody, 4G10. All blots were subsequently stripped and re-probed with rabbit anti-CD19 to show loading. Signals obtained from the Western blots in mice samples (B) were quantified by densitometry and the mean ±SE of the ratio of the intensity of the anti-phosphotyrosine and anti-CD19 signals at each time point from three independent experiments were plotted, permitting a comparison of the relative tyrosine phosphorylation of CD19 in primary B cells from *lyn*^{+/+} and *lyn*^{-/-} mice.

phosphorylation to be normal in the absence of Lyn, we wished to determine whether the kinase responsible was either a Src-family PTK or Syk. We therefore stimulated *lyn*^{-/-} and control B cell lines with F(ab')₂ anti-IgM in the presence of the Src-family specific inhibitor pp2 (Hanke *et al.*, 1996) and then determined the extent of CD19 phosphorylation. Figure 4.2A shows that in both *lyn*^{-/-} and *lyn*^{+/+} B cell lines the BCR-induced phosphorylation of CD19 is inhibited completely by pp2 but unaffected by the control drug, pp3.

A number of reports implicate Lyn as the PTK responsible for CD19 phosphorylation in Lyn-sufficient B cells (Roifman & Ke, 1993; van Noesel *et al.*, 1993). While our data indicate that a Src-related PTK is responsible for CD19 phosphorylation in the absence of Lyn (Fig. 4.2A), we are unable to identify the specific PTK involved. We also examined CD19 phosphorylation in a B cell line carrying a genetic modification encoding a constitutively activated form of Lyn (*lyn*^{+up}: Y508F (Harder *et al.*, 2001)). While BCR cross-linking is required to induce phosphorylation of CD19 in the control B cell line, tyrosine phosphorylation of CD19 was detected in the unstimulated *lyn*^{+up} B cell line and enhanced by BCR cross-linking (Fig. 4.2B). Collectively these results strongly support a role for Lyn in CD19 phosphorylation following BCR ligation. These data also suggest, however, that in the absence of Lyn, other members of the Src family mediate the BCR-induced phosphorylation of CD19. The relative contribution of other Src family PTK in wild type or Lyn-deficient B cells cannot be resolved at present.

4.3.3: Lyn is not required for CD19 to recruit PI3K and enhance calcium flux after co-ligation with BCR

The costimulatory role of CD19 in B cell activation is mediated by the recruitment of the signalling molecules such as PI3K to tyrosine phosphorylation sites on CD19 (Tuveson *et al.*, 1993; Weng *et al.*, 1994). Although we have shown that other Src-family PTK can compensate for the absence of Lyn in BCR-dependent phosphorylation of CD19, Lyn might still be essential for recruitment of specific effector signalling molecules to the cytoplasmic domain of CD19. To test this possibility, we immunoprecipitated CD19 from resting and stimulated *lyn*^{+/+} and *lyn*^{-/-}

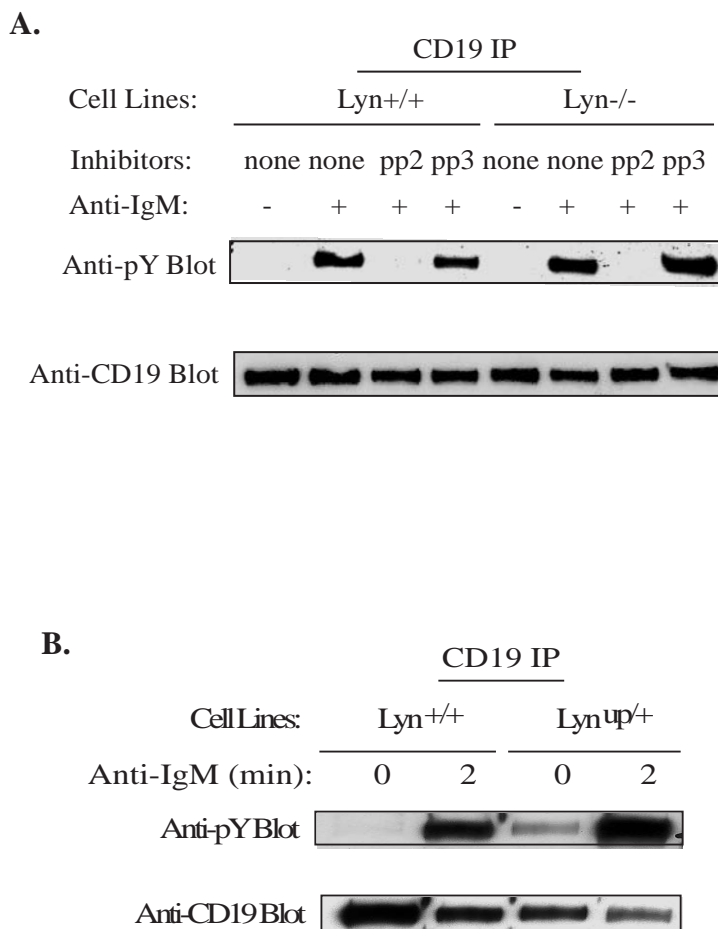

Figure 4.2. CD19 is a substrate of Src-family PTK activity. (A). Control and Lyn-deficient B cell lines were untreated or pre-treated with either pp2 or the control compound pp3 before BCR stimulation with F(ab')₂ anti-IgM. CD19 immunoprecipitates were blotted sequentially with anti-phosphotyrosine antibody then anti-CD19 sera as described in Fig.4.1. (B). Control and Lyn^{up/+} B cell lines were stimulated, lysed and CD19 immunoprecipitated. Phospho-CD19 was revealed with anti-phosphotyrosine antibody and total CD19 by re-probing with rabbit anti-CD19 serum.

primary B cells and looked for co-precipitation of PI3K. We found that PI3K was recruited to CD19 equally well in *lyn*^{-/-} and *lyn*^{+/+} primary B cells following BCR ligation (Fig. 4.3). Recruitment of PI3K to CD19 is thought to be important in the enhanced calcium flux engendered by BCR and CD19 co-ligation (Li & Carter, 2000). We therefore tested the functional relevance of PI3K recruitment to CD19 in *lyn*^{-/-} splenic B cells by comparing the calcium flux induced by BCR ligation alone with that induced by co-ligation of the BCR with CD19. As expected, in control B cells, co-ligation of CD19 with the BCR induced a higher calcium flux than BCR ligation alone (Fig. 4.4A). Importantly, we observed a similarly enhanced calcium flux upon BCR and CD19 co-ligation in *lyn*^{-/-} B cells (Fig. 4.4B) indicating that the absence of Lyn affects neither the CD19-dependent recruitment nor function of effector molecules essential for the mobilization of Ca²⁺.

4.3.4: Co-ligation of the BCR with CD19 increases MAP kinase phosphorylation in the absence of Lyn

Besides raising calcium flux, co-ligation of CD19 with the BCR can also enhance the activation of MAP kinase (Tooze et al., 1997). To determine whether the role of CD19 in regulating MAP kinase activation is affected by the absence of Lyn, purified splenic B cells from *lyn*^{+/+} and *lyn*^{-/-} mice were stimulated by cross-linking the BCR, CD19 or both, and ERK1/2 activation was measured by detection of its phosphorylated forms. In *lyn*^{+/+} B cells, cross-linking CD19 or the BCR alone resulted in no or low-level phosphorylation of ERK1/2 respectively, whereas co-ligation induced a signal much stronger than that induced by either stimulus alone (Fig.4.5). Ligation of the BCR on *lyn*^{-/-} B cells induced stronger ERK1/2 phosphorylation compared with control B cells, a result consistent with the previously reported hyper-activity of ERK1/2 (Chan et al., 1998). Curiously, cross-linking CD19 alone in *lyn*^{-/-} B cells induced a low level of ERK1/2 phosphorylation. While the basis for this observation is currently being investigated, it is consistent with Lyn being a negative regulator of MAP kinase activity (Chan et al., 1997). Furthermore, the already strong ERK1/2 phosphorylation induced by BCR cross-linking on *lyn*^{-/-} B cells was enhanced by co-ligation of CD19 with the BCR (Fig.4.5), clearly

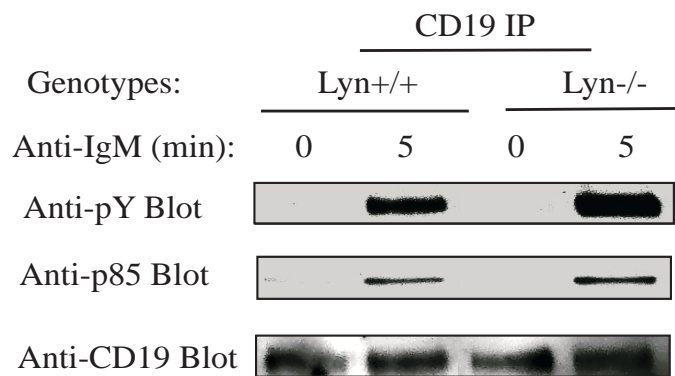

Figure 4.3. Recruitment of PI3K to CD19 is intact in *lyn*^{-/-} B cells. Purified splenic B cells from control and *lyn*^{-/-} mice were stimulated for the indicated times. CD19 was immunoprecipitated and the Western blot probed with anti-phosphotyrosine (upper panel) and rabbit anti-PI3K serum (middle panel). After stripping, the blot was re-probed with rabbit anti-CD19 to reveal the amount of CD19 loaded (lower panel).

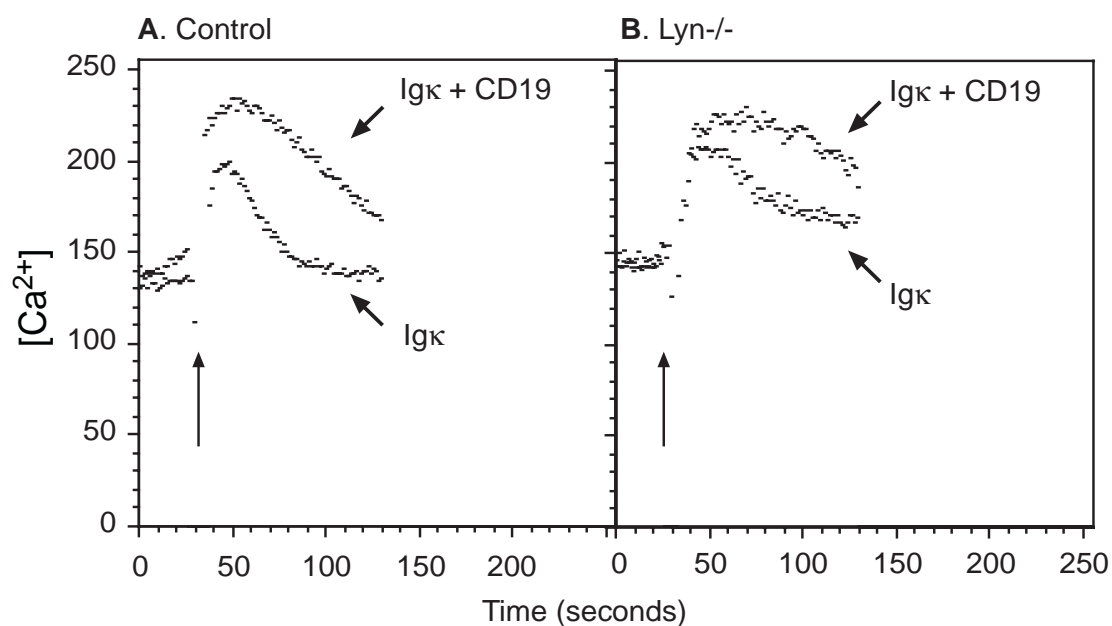

Figure 4.4. Co-ligation of the BCR with CD19 enhances Ca^{2+} flux in control and *lyn*^{-/-} B cells. Splenocytes from (A) control or (B) *lyn*^{-/-} mice, loaded with the calcium sensitive dye indo-1, were stained with biotinylated monoclonal antibodies for Igκ alone or together with anti-CD19 as indicated. B cells, specifically labeled with FITC-conjugated anti-B220, were analysed by flow cytometry. After establishing baseline fluorescence, cross-linking was initiated by addition of avidin (indicated by the vertical arrow) and the analysis continued for the times indicated. The plots represent the fluorescence ratio of gated B220⁺ cells. The result shown is from one of three independent experiments. Previous analyses have demonstrated no effect of anti-B220 staining on Ca^{2+} flux ((Smith et al., 1998) and data not shown).

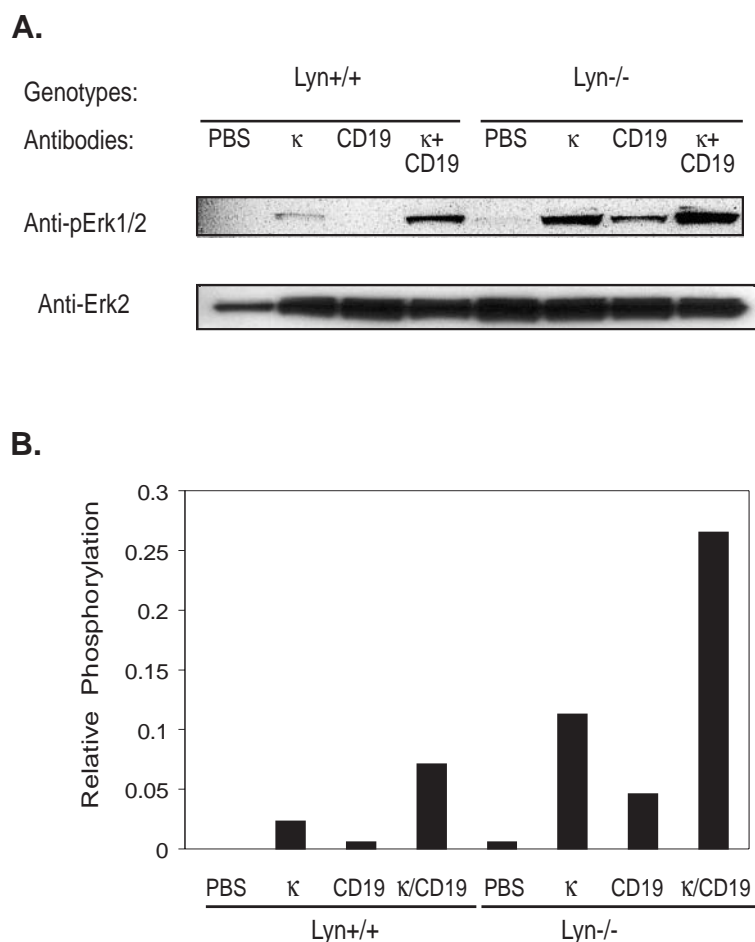

Figure 4.5. Co-ligation of CD19 with the BCR enhances phosphorylation of ERK1/2 in control and *lyn*^{-/-} B cells. Purified splenic B cells (2×10^6 /lane) were pre-incubated with either medium, biotinylated anti-Ig κ , biotinylated anti-CD19 or both antibodies together. B cell stimulation was initiated by addition of avidin and halted after 2 min. (A). Whole cell lysates were resolved by SDS-PAGE, transferred to nitrocellulose membranes and probed with antibodies specific for the phosphorylated form of ERK1/2 (upper panel). Membranes were stripped and re-blotted with anti-Erk1/2 to reveal protein loading (lower panel). (B). The ratio of the intensity of the phospho-ERK1/2 and ERK1/2 signals for each stimulation condition was determined by densitometric analysis, allowing a comparison of the relative phosphorylation of ERK1/2 between samples.

demonstrating that the role of CD19 in enhancing MAP kinase activity remains intact in Lyn-deficient B cells. Collectively, these data demonstrate that the ability of CD19 to enhance BCR signalling is not dependent on Lyn.

4.3.5: Activation of Lyn and total protein tyrosine phosphorylation following BCR ligation are unaffected by the absence of CD19.

Having found the BCR-associated functions of CD19 to be independent of Lyn, we next examined the suggested role of CD19 in the activation of Lyn. If, as proposed, CD19 is essential for the amplification of Lyn activity in B cells following BCR ligation (Fujimoto et al., 2000a), then in the absence of CD19, Lyn activity should be diminished. We measured Lyn specific activity in CD19^{-/-} and CD19^{+/+} splenic B cells before and after BCR ligation (Fig. 4.6A). In control B cells, Lyn activity increased approximately 1.6 fold after 2 minutes of BCR cross-linking. The activity of Lyn in CD19^{-/-} primary B cells increased about 1.9 fold after equivalent BCR stimulation (Fig. 4.6A), demonstrating that the activation of Lyn in B cells is not affected by the absence of CD19. It is important to note that both the baseline and stimulated activity of Lyn are approximately equal in both cell types indicating an approximately equal increase in the absolute activity in control and CD19^{-/-} B cells. In agreement with this result, we found the level of phosphorylated Lyn in CD19^{-/-} and CD19^{+/+} B cells to increase comparably following BCR ligation (Fig. 4.6B). Finally, the level of tyrosine phosphorylation induced by BCR ligation was similar in control and CD19^{-/-} splenic B cells (Fig. 4.6C) suggesting that many of the early steps in B cell activation are unaffected by the absence of CD19.

4.3.6: Lyn-dependent tyrosine phosphorylation of CD22 and FcγRIIB is comparable to that of wt type mice in CD19-deficient mice.

CD22 and FcγRIIB are two important B cell surface molecules that negatively control BCR-induced signals. Since Lyn was reported to be the primary PTK that phosphorylates these surface molecules in B cells (Smith et al., 1998; Chan et al., 1998), we next tested the Lyn-dependent tyrosine phosphorylation of CD22 and FcγRIIB in CD19- deficient primary B cells after BCR stimulation to confirm that the

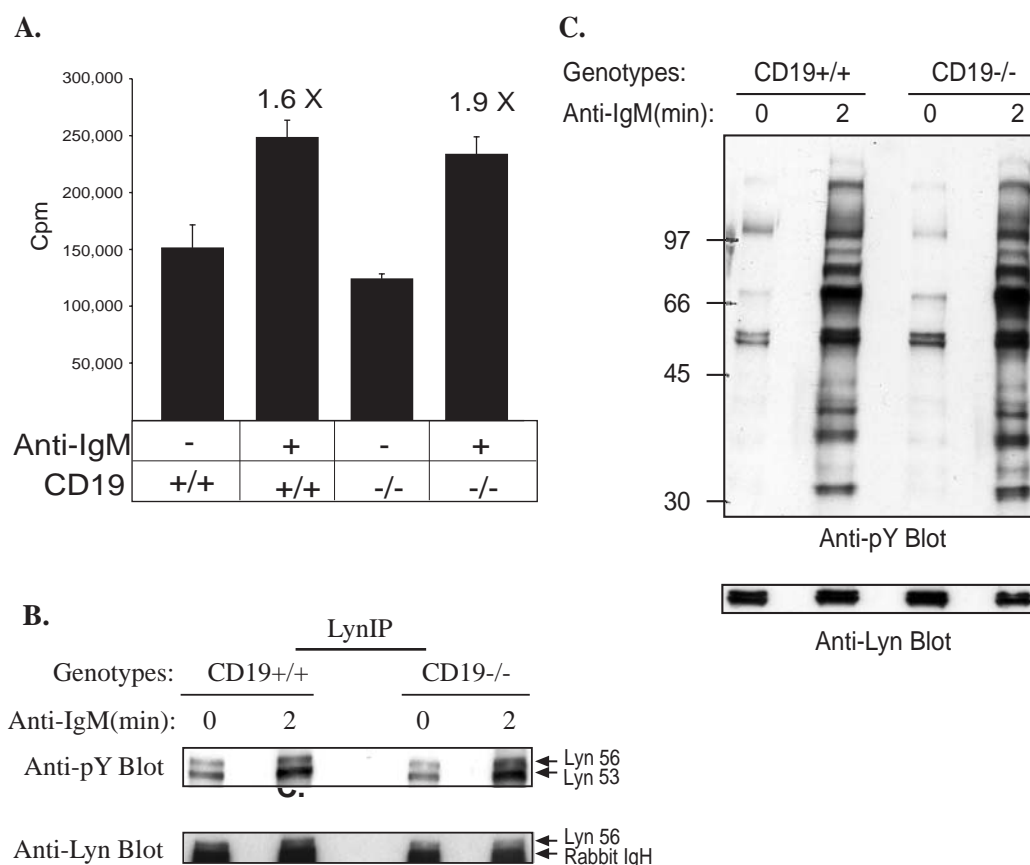

Figure 4.6. Lyn kinase activity, phosphorylation and total protein phosphorylation in control and CD19^{-/-} B cells. (A). Lyn was immunoprecipitated from normalized cell lysates prepared from control and CD19^{-/-} B cells either unstimulated or stimulated with F(ab')₂ anti-IgM for 2 minutes. Lyn kinase assay was performed as described in Chapter 2. The relative mean Lyn-kinase activity from triplicate assays is plotted as is the fold increase observed in each sample following stimulation. The values represent the mean \pm SE of 2 independent experiments. (B). Splenic B cells from CD19^{+/+} and CD19^{-/-} mice were treated as in (A). Lyn was immunoprecipitated from 100 μ g of total protein, Western blotted and probed to detect phosphorylated tyrosines before stripping the membrane and re-probing with anti-Lyn. (C). Splenic B cells from the mice were treated as in A. Protein (7.5 μ g) from each sample was Western blotted and probed for phosphorylated tyrosines. Positions of molecular weight standards are shown on the left. The membrane was subsequently stripped and re-probed with anti-Lyn as a loading control.

activity of Lyn is not affected by the loss of CD19. We found that CD22 is constitutively tyrosine phosphorylated in the wild type primary B cells and BCR crosslinking increase this phosphorylation. In the Lyn-deficient B cells, however, CD22 phosphorylation is barely detectable and BCR ligation failed to enhance the weak phosphorylation of CD22 at two time points tested. Quite different from *lyn*^{-/-} mice, *CD19*^{-/-} primary B cells demonstrated strong phosphorylation of CD22 similar to the control both before and after BCR stimulation (Fig 4.7A). Likewise, tyrosine phosphorylation of FcγRIIB after co-ligation with the BCR in CD19-deficient primary B cells looks more like that of wild type control than that of Lyn-deficient B cells, which is compromised (Fig 4.7B). These results agree with the intact Lyn activity in the absence of CD19.

4.3.7: Inhibitory role of CD22 and FcγRIIB is Lyn-dependent and CD19-independent .

In addition to the phosphorylation studies, we checked the functions of these surface molecules in the absence of CD19. In particular, we tested the ability of CD22 co-ligation to inhibit BCR mediated calcium flux in *CD19*^{-/-} B cells and FcγRIIB co-ligation to inhibit BCR mediated ERK activation, as these activities have been found to depend to varying degrees on Lyn (Chan et al., 1998; Chan et al., 1997; Nishizumi et al., 1998; Smith et al., 1998). As expected, cross-linking CD22 with the BCR inhibited calcium flux in control but not *lyn*^{-/-} B cells (Fig. 4.8A, B). In contrast to Lyn-deficient B cells, co-ligation of CD22 with the BCR on *CD19*^{-/-} B cells inhibited calcium flux with a kinetics and to a degree comparable to that in control B cells (Fig. 4.8C), supporting the notion that the Lyn dependent, CD22 mediated-inhibition of calcium flux induced by BCR ligation is not dependent on CD19. Finally, we determined whether the inhibition of ERK phosphorylation mediated by co-ligating FcγRIIB with the BCR was sensitive to the presence of Lyn or CD19. Control B cells showed greatly diminished ERK phosphorylation when stimulated with intact anti-IgM compared to F(ab')₂ anti-IgM (Fig. 4.8D). Both stimuli induced equal levels of total tyrosine phosphorylation while only intact anti-IgM induced FcγRII phosphorylation (data not shown). FcγRII was less inhibitory of ERK phosphorylation in *lyn*^{-/-} B cells (Fig. 4.8D), consistent with a role for Lyn in FcγRII

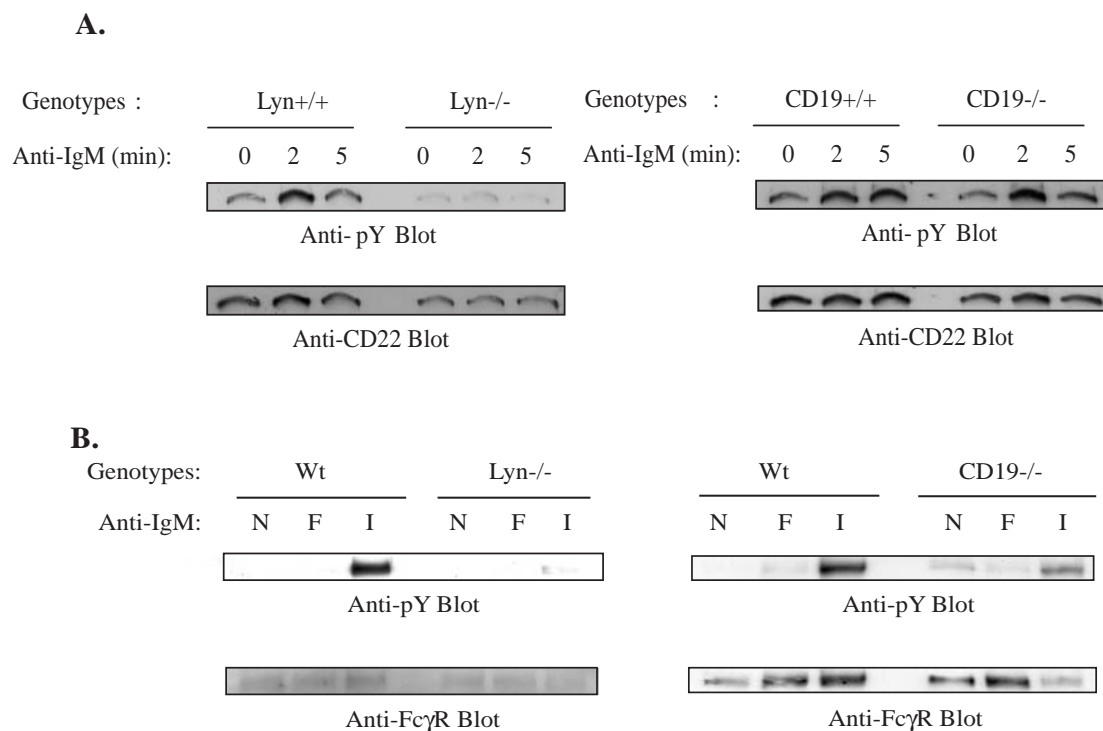

Figure 4.7. Comparison of CD22 and FcγRIIb phosphorylation in *Lyn* and *CD19*-deficient mice. Purified splenic B cells from control, *Lyn*^{-/-}, and *CD19*^{-/-} mice were stimulated either with (A) F(ab)₂ anti-IgM, or (B) F(ab)₂ portion (F), intact (I) anti-IgM or no stimulus (N). CD22 (A), and FcγRIIB (B) were immunoprecipitated, and Western blotted with anti-phosphotyrosine Ab before the filters were stripped and re-probed with anti-CD22 (A) and anti-FcγR (B) Abs for loading control.

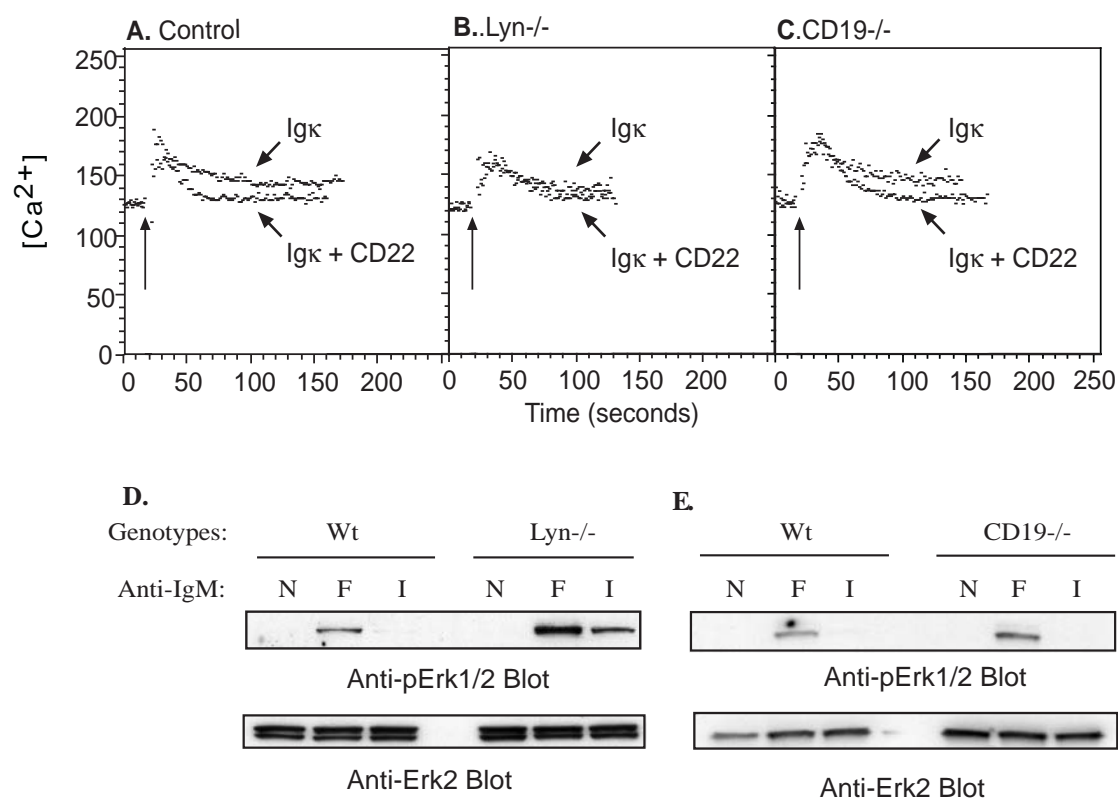

Figure 4.8. *Lyn*-dependent inhibition by *CD22* and *FcγRIIB* is intact in *CD19*^{-/-} B cells. Splenocytes, previously loaded with the calcium sensitive dye indo-1, were labelled with biotinylated antibodies specific for Igκ alone or together with anti-*CD22*. The cells were subsequently stained with FITC-conjugated anti-B220. After establishing baseline indo-1 fluorescence by flow cytometry, receptors were cross-linked by the addition of avidin to a final concentration of 20 μg/ml. The resultant flux in intracellular Ca²⁺ in (A) control, (B) *lyn*^{-/-} and (C) *CD19*^{-/-} B220⁺ cells was monitored for the indicated times. The plots depict calcium content as defined by fluorescence ratio as a function of time and the experiment was repeated twice. Purified splenic B cells from (D) control and *lyn*^{-/-} and (E) control and *CD19*^{-/-} were either not treated (N), or treated with F(ab')₂ goat anti-IgM fragments (F), or intact goat anti-IgM antibody (I) for 2 min at 37°C. Total cell lysates were separated by electrophoresis, blotted and probed for phosphorylated ERK1/2 (upper panel). The filter was subsequently stripped and re-probed with anti-ERK2 to show protein loading (lower panel). The rabbit anti-ERK2 Abs used in E belonged to a different batch than was used in D and appeared to have less cross-reactivity with ERK1.

mediated inhibition in B cells (Chan et al., 1997; Wang et al., 1996). CD19^{-/-} B cells, on the other hand, showed an inhibition of ERK phosphorylation similar to controls (Fig. 4.8E). Collectively these results are most consistent with the regulatory activity of Lyn induced by BCR stimulation being unaffected by the absence of CD19.

4.4: DISCUSSION

The outcome of B lymphocyte stimulation is the sum of the positive and negative signals delivered through the BCR. Studies over many years have defined CD19 as a prominent positive regulator of B cell activation. These studies have included biochemical analysis of the consequences of co-ligating CD19 with the BCR (Doody et al., 1996) and analysis of B cells from CD19 deficient mice (Engel et al., 1995; Rickert et al., 1995). All available evidence supports the notion that CD19 functions to amplify signalling from the BCR. Conversely, the Src-related tyrosine kinase Lyn has been identified as a critical negative regulator or inhibitor of B cell activation. In mouse primary B cells, Lyn has the unique role of phosphorylating tyrosines within the ITIMs of several key inhibitory proteins thereby providing docking sites for phosphatases that down-regulate B cell activation (Adachi et al., 1998; Chan et al., 1998; Cornall et al., 1998; Ho et al., 1999; Nishizumi et al., 1998; Smith et al., 1998). At certain points, however, CD19, Lyn and the pathways emanating from them are thought to intersect. Lyn has long been suspected as the principal tyrosine kinase responsible for phosphorylating CD19 following B cell activation (Roifman et al., 1993; van Noesel et al., 1993). Similarly, CD19 co-ligation with the BCR intensifies MAP-kinase activation (Tooze et al., 1997) while the absence of Lyn results in hyper-activation of MAP-kinase (Chan et al., 1997), suggesting a convergence of these pathways at this point. Ca²⁺ flux due to BCR ligation is enhanced in the absence of Lyn (Smith et al., 1998) but either delayed or normal in the absence of CD19 (Fujimoto et al., 1999a; Sato et al., 1997). A similar reciprocal relationship between Lyn and CD19 is apparent in the status of Akt. Akt is reported to be hyper-phosphorylated in Lyn-deficient B cells (Li et al., 1999), but hypo-phosphorylated following BCR ligation in CD19-deficient B cells (Otero et al., 2001). Given these apparently opposite activities for Lyn and CD19 in B cell activation, recent findings suggesting that CD19 phosphorylation depends entirely on Lyn (Fujimoto et al., 2000a) and that increased Lyn activity should depend on phosphorylated CD19

(Fujimoto et al., 2000a; Fujimoto et al., 1999b) were surprising. If these observations and the resultant model are correct, one might expect that the regulatory activities of CD19 and Lyn would show a degree of inter-dependence and that the B cell phenotype resulting from the absence of CD19 or Lyn might show a degree of redundancy.

The study reported here was undertaken to clarify the relationship between Lyn and CD19 in mouse B cells and to define points at which the regulatory roles of these molecules converged. To this end we examined CD19 phosphorylation following BCR ligation in the presence and absence of Lyn and found it to increase and decrease with a kinetic essentially the same as in control B cells (Fig. 4.1). We examined recruitment of the ancillary signalling molecule PI3K to CD19 following B cell activation and found this also to be unaltered by the absence of Lyn (Fig. 4.3). Moreover, the enhanced Ca^{2+} flux and phosphorylation of ERK1/2 following co-ligation of CD19 with the BCR remained intact in *lyn*^{-/-} B cells. The fact that we saw no effect of Lyn deficiency on CD19 function raises the question of whether Lyn has any role in CD19 activation following BCR ligation. We did find CD19 phosphorylation in both *lyn*^{+/+} and *lyn*^{-/-} B cell line to be blocked by the Src-kinase specific inhibitor pp2, indicating that Src-related tyrosine kinases are responsible for BCR-dependent CD19 phosphorylation. CD19 was also constitutively phosphorylated in a cell line containing a constitutively active form of Lyn, identifying CD19 as a potential substrate of Lyn. Thus the often suggested role for Lyn in CD19 phosphorylation is either shared with, or able to be replaced by, other Src-related kinases found in B cells. A similar conclusion has been reached after analysis of Lyn's other suggested positive roles, such as the activation of Syk (Chan et al., 1997). Our data demonstrate no unique role for Lyn in CD19-mediated signalling processes initiated by BCR ligation.

We also examined the reported role of CD19 in amplifying Lyn activity in B cells (Fujimoto et al., 2000a; Fujimoto et al., 1999b). In a current model, Lyn phosphorylates and subsequently binds to tyrosine 513 in the cytoplasmic tail of CD19 via its SH2 domain. Lyn then phosphorylates tyrosine 482 of CD19 through "processive phosphorylation" which allows recruitment of another Lyn molecule

leading to Lyn transphosphorylation and/or autophosphorylation. The ability of Lyn to amplify its own activity via its interaction with CD19 is proposed to account for the majority of the increase in Lyn activity in B cells following BCR ligation (Fujimoto et al., 2000a; Fujimoto et al., 1999b). Such a model might predict that the absence of CD19 would negatively affect the unique functions of Lyn following BCR stimulation. Our analysis of these activities, however, has failed to reveal any effect of the absence of CD19 on Lyn activity. First, we measured Lyn kinase activity in CD19 sufficient and deficient B cells following BCR ligation and found the magnitude of the increase to be independent of the presence or absence of CD19 (Fig. 4.6). Similarly we found the ability of CD22 to inhibit Ca^{2+} flux and Fc γ RIIB to inhibit ERK phosphorylation following co-ligation with the BCR to be unaffected by the absence of CD19 (Fig. 4.8). We and others have previously shown these activities to depend either entirely or predominantly on the presence of Lyn (Chan et al., 1998; Chan et al., 1997; Cornall et al., 1998; Smith et al., 1998). While Lyn almost certainly interacts with CD19 in normal circumstances (see for example Fig 3.4), our data support the notion that this interaction is not essential for the function of either CD19 or Lyn.

The biochemical independence of CD19 and Lyn reported here is consistent with the biology of B cells derived from mice deficient in either molecule. CD19^{-/-} B cells have been reported to have either normal or diminished proliferation in response to BCR ligation (Engel et al., 1995; Rickert et al., 1995). CD19^{-/-} mice also show diminished levels of IgM in serum and fail to generate germinal centers following immunization with T cell dependent (TD) antigen in alum (Engel et al., 1995; Rickert et al., 1995). Lyn-deficient B cells, on the other hand, hyper-proliferate following BCR ligation (Chan et al., 1997; Wang et al., 1996) and germinal centers form in *lyn*^{-/-} mice following immunization (L. Blink and DT, unpublished). *Lyn*^{-/-} mice also contain 10 times the normal level of IgM in their serum (Hibbs et al., 1995). These phenotypic traits are consistent with Lyn and CD19 acting independently in B cell activation.

If Lyn and CD19 are critical mediators of negative and positive signalling from the BCR, respectively, and if the balance between positive and negative pathways is

essential for normal B cell activation, at what points do Lyn-dependent and CD19-dependent pathways impinge on each other? While our data are not exhaustive on this issue, we find intersection in both the regulation of MAP-kinase and in Ca^{2+} flux. That is, CD19 is a positive regulator of both MAP-kinase and Ca flux while Lyn is a negative regulator of both. How this regulation occurs is not clear. Does Lyn act directly or indirectly on CD19 to diminish these responses? Since Lyn is responsible for mobilization of phosphatases to the plasma membrane it is possible that Lyn may regulate CD19 activity via the activation of a phosphatase such as SHP-1 that subsequently modulates the phosphorylation of CD19. Indeed, the hyperphosphorylation of CD19 in Me^v B cells has been attributed to the absence of SHP-1, although this affect is itself thought to be indirect (Somani et al., 2001). Furthermore, mice transgenic for human CD19 show a B cell phenotype and develop an autoimmune disease that is remarkably similar to that found in Lyn-deficient mice (Hibbs et al., 1995; Nishizumi et al., 1995; Sato et al., 2000). That is, too little Lyn could be equivalent to a functional excess of CD19. The dephosphorylation of CD19 apparent in $\text{lyn}^{-/}$ B cells (Fig. 4.1) indicates that Lyn does not act indirectly via, for example, activation of phosphatase to regulate the level of CD19 phosphorylation. This in turn suggests that Lyn exerts its influence on B cell signalling pathways parallel to or downstream of CD19.

Interestingly, we noticed that CD19 ligation alone lead to the activation of ERK in $\text{lyn}^{-/}$ B cells (Fig 4.5). The reason for this could be because CD19 is constitutively associated with BCR to some degree, and ligation of CD19 triggered a low level of BCR signaling that ultimately resulted in ERK MAP kinase activation. In wild-type B cells, this signal may be too small to detect, but in $\text{lyn}^{-/}$ B cells, which are hyper-responsive to BCR ligation, this signal is detectable. Alternatively, it could be that the absence of Lyn may have already caused ERK activity to be near its threshold level in the resting state through some CD19 independent mechanism (which are investigated in the next chapter). Ligation of CD19 may therefore induce ERK activation in the knockout that will not occur in wild type B cells.

Several elements of our data are in direct contradiction to those reported previously on the co-dependence of Lyn and CD19 (Fujimoto et al., 2000a; Fujimoto et al., 1999b). Most importantly we find normal phosphorylation of CD19 in $\text{lyn}^{-/}$ B cells

and normal activation of Lyn in CD19^{-/-} B cells. These results, therefore, question the model of 'processive amplification of Src-kinases' in B cell activation in which Lyn is the obligate kinase for CD19 phosphorylation and CD19 is the obligate scaffold for the amplification of Src family kinase activation following BCR cross-linking (Fujimoto et al., 2000a; Fujimoto et al., 2000b; Fujimoto et al., 2001; Fujimoto et al., 1999b; Hasegawa et al., 2001). As mentioned above, the biology of both the mice and the B cells deficient in either Lyn or CD19 best fits a model of B cell activation in which the activation of Lyn and CD19 are not dependent events, a notion consistent with the biochemistry presented here. While Lyn and CD19 may interact in the manner described (Fujimoto et al., 2000a), it is clearly not essential for the function of either. While we have no explanation for the failure to see CD19 phosphorylation in *lyn*^{-/-} B cells (Fujimoto et al., 2000a), the gene targeted mice used in our experiments differ from those used by Tedder and colleagues, although several studies suggest they are indistinguishable (Chan et al., 1997; Engel et al., 1995; Hibbs et al., 1995; Rickert et al., 1995). Our studies indicate, however, that previous measurements of Lyn kinase activity (Fujimoto et al., 1999a; Fujimoto et al., 2000a) were sub-optimal. In establishing conditions for measuring Lyn activity, we compared the peptide cdc2(6-20) with the Src-optimal peptide (Sicilia et al., 1998) as substrates for Lyn and found a 22 fold difference in favour of SOP (Beavitt SJ and Hibbs ML., data not shown). Hck has also been reported to phosphorylate SOP more efficiently than cdc2 (Sicilia et al., 1998) suggesting cdc2 is not the optimal substrate for assessing Src family PTK activity. It may be that the use of the cdc2 peptide diminishes the sensitivity of the assay and makes differences difficult to resolve.

In conclusion, we have found that CD19 and Lyn exert opposite and independent effects following B cell activation. CD19 loss does not affect the activity of Lyn and Lyn is not required for CD19 phosphorylation although it may play a role when present. We did find, however, that Lyn exerts a negative influence on signalling pathways augmented by CD19 co-ligation with the BCR. If Lyn were to act downstream of CD19 this would allow greater flexibility in the extent to which various pathways were modulated in different stimulatory circumstances.

CHAPTER 5: LYN DOWN-REGULATES PI3K IN PRIMARY MURINE B LYMPHOCYTES

----- Novel mechanisms to explain the hyper-sensitive phenotype of Lyn-deficient mice

5.1.SUMMARY

The phenotype of Lyn knockout mice suggests this Src family protein tyrosine kinase to be a negative regulator of B cell signalling. The negative regulatory mechanisms of Lyn in B cells, however, are not fully understood. We report here that the hyper-sensitive phenotype of Lyn-deficient primary B cells in response to BCR ligation such as Erk MAP kinase activation, calcium elevation and hyper-proliferation were attenuated by removal of phosphoinositide-3 kinase (PI3K) activity. Furthermore, the specific activity of PI3K from Lyn-deficient primary B cells was found to be elevated both before and after BCR-stimulation. Finally, the activity of other Src family PTKs in Lyn -deficient primary B cells was demonstrated to be required for the elevated PI3K activation in Lyn -deficient B cells. On the basis of these data we propose a novel inhibitive mechanism of Lyn in BCR signalling acting on PI3K.

5.2: INTRODUCTION

The signals propagated through the BCR are central to B cell development and production of antibodies in response to antigen. The early events of signal transduction through the BCR is the activation of a series of non-receptor protein tyrosine kinases that belong to the Src family, the Zap/Syk family, and the Tec/Btk family. Once activated, they transduce signals received from the BCR to the nucleus by catalysing phosphorylation of the tyrosine residues in either the cytoplasmic domains of some surface molecules or within intracellular adaptor proteins that in turn recruit cytosolic signalling molecules close to the plasma membrane for activation. Of these three kinds of non-receptor PTKs, Src PTKs are the first to be activated and play an important role in signal initiation.

As the predominant Src family PTK member expressed in B cells, Lyn participates in the activation of the BCR signalling cascade via phosphorylating the Ig α / β subunit of BCR complex (Chan et al., 1997), Syk (Cornall et al., 1998; Hibbs et al., 2002), and CD19 (Fujimoto et al., 2000a; Xu et al., 2002). However, Lyn is also involved in down-regulation of BCR signalling by phosphorylating the immunoreceptor tyrosine-based inhibitory motifs (ITIMs) of several inhibitory receptors including CD22 (Smith et al., 1998; Nishizumi et al., 1998), Fc γ RIIb (Chan et al., 1998; Nishizumi et al., 1998), CD72 (Adachi et al., 1998), paired Ig-like receptor-B (Ho et al., 1999), and PD-1 (Okazaki et al., 2001). The phosphorylation of inhibitory surface molecules is unique to Lyn while phosphorylation of BCR subunits and their associated co-stimulatory molecules is redundant (Chan et al., 1997; Xu et al., 2002). Therefore, B cells from Lyn-deficient mice are hyper-responsive to BCR stimulation in terms of MAP kinase activation, calcium flux and proliferation. As a consequence, the Lyn-deficient mice develop autoimmune disease similar to systemic lupus erythematosus (SLE) as they age (Hibbs et al., 1995; Nishizumi et al., 1995).

BCR ligation also induces activation of phosphoinositide-3 kinase (PI3K) (Gold et al., 1992), which is a key enzyme producing phospholipid second messengers and has an important role in various signal transduction pathways (Fruman et al., 1998). PI3K family members were classified into three groups according to their structure and substrate specificity (Katso et al., 2001). Among them, class IA heterodimeric PI3Ks consisting of a catalytic subunit (p110 α , p110 β , p110 δ) and a regulatory subunit (p85 α , p85 β , p55 γ) are activated by tyrosine-kinase-associated receptors, including antigen, co-stimulatory and cytokine receptors (Okkenhaug et al., 2003). PI3K mutant mice deficient for the genes encoding p85 α , the most abundantly and ubiquitously expressed regulatory subunit of class IA PI3Ks, have been generated (Terauchi et al., 1999; Suzuki et al., 1999; Fruman et al., 1999). The B cell phenotype of these mice was more severe than that of T cells, probably due to an alternative regulatory subunit other than p85 α in T cells (Fruman et al., 1999). In the absence of PI3K activity, primary B cells demonstrated a general immunodeficient phenotype that resembled Xid mice (Suzuki et al., 1999; Fruman et al., 1999).

The B cell phenotype in the absence of PI3K activity is opposite to that of Lyn -deficient B cells, raising the possibility that there is some connection between these two molecules. Indeed, several lines of evidence suggest that Lyn might negatively regulate PI3K pathway. First, the activity of Akt, a molecule down-stream of PI3K, was found to be elevated after BCR crosslinking in Lyn-deficient primary B cells (Li, et al., 1999; Craxton et al., 1999). Second, tyrosine phosphorylation of p110, the catalytic subunit of PI3K, was enhanced in a Lyn-deficient DT40 chicken B cell line (Craxton et al., 1999). Third, PIP3, the product of PI3K, was increased in Lyn-deficient mast cells (Parravicini et al., 2002). Here, we investigate the role of Lyn in PI3K pathway in murine primary B cells. We find that the hyper-sensitivity of the Lyn-deficient B cells to BCR ligation is dampened by loss of PI3K activity and specific enzymatic activity of PI3K is elevated in Lyn-deficient primary B cells. Furthermore, we find that the Src-family PTKs other than Lyn are the factors causing the elevated PI3K activity in the Lyn-deficient mice.

5.3: RESULTS

5.3.1: The hyper-responsive phenotype of Lyn-deficient primary B cell was suppressed by PI3K inhibitors.

Mice deficient for *lyn* are predisposed to autoimmunity, which is accountable, in part, by the *in vitro* biochemical findings that Lyn-deficient primary B cell have enhanced Erk activation (Chan et al., 1997) and elevated calcium flux (Chan et al., 1998; Cornall et al., 1998; Smith et al., 1998) in response to BCR ligation. However, the molecular mechanisms that lead to the hyper-responsiveness of Lyn-deficient B cell have not been fully elucidated. Since PI3K was recently reported to be critical for BCR-induced Erk MAPK activation and intracellular calcium flux in B cells (Jacob et al., 2002; Marshall et al., 2000; Jou et al., 2002), we employed a pharmaceutical approach to investigate the possibility that *lyn* works through PI3K in B cells. After treatment with wortmannin, a chemical compound that specifically inhibits PI3K (Arcaro et al., 1993), primary B cells from both wild-type and Lyn -deficient mice were stimulated with F(ab')₂ goat anti-IgM, lysed with detergent and

A.

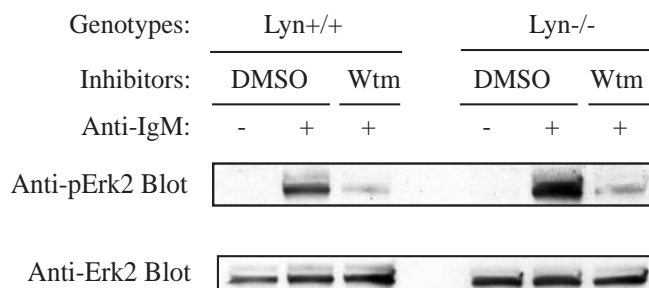

B.

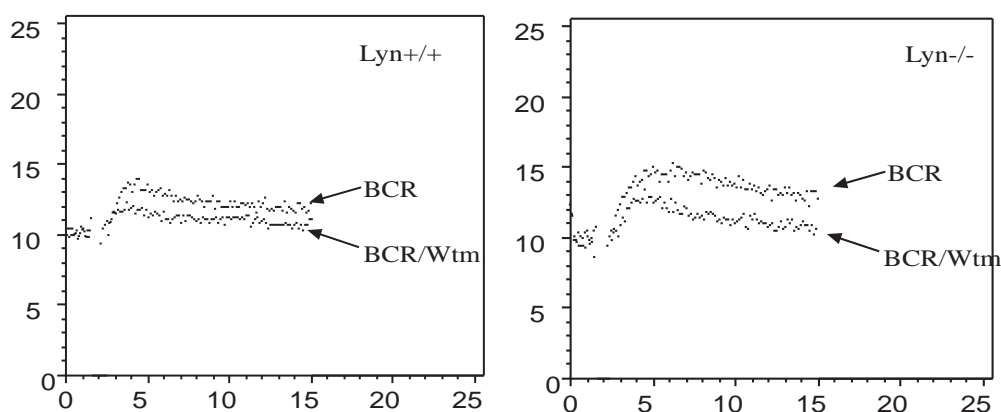

Figure 5.1. The hyper-responsiveness of Lyn-deficient primary B cells after BCR stimulation is corrected by Wortmannin

(a.). Splenic B cells from both wild-type and Lyn -deficient mice were treated with either DMSO or 50nM wortmannin (Wtm) before being stimulated with 40 μ g/ml goat anti-mouse IgM. Whole cell lysates were probed with anti-phospho-Erk2 Abs. The filter was stripped and re-probed with anti-Erk2. (b.). Splenic B cells from wild type and Lyn-deficient mice were loaded with the calcium-sensitive dye indo-1, and then treated with or without 50nM wortmannin. After establishing baseline fluorescence, BCR stimulation was initiated by addition of goat anti-IgM and the resulting calcium flux monitored for 10 minutes.

checked for activated/phosphorylated form of Erk by western blotting. Remarkably, the BCR-induced hyper-phosphorylation of Erk in Lyn-deficient primary B cells was reduced to the level of wild-type control by this PI3K inhibitor (Fig. 5.1A). Likewise, wortmannin also inhibited the elevated intracellular calcium flux in response to BCR crosslinking in Lyn -deficient primary B cells (Fig. 5.1 B). A structurally different chemical LY294002 that also specifically inhibits PI3K activity (Vlahos et al., 1994) was also used to treat the sample, and similar results were obtained in the inhibition of Erk MAP kinase activation (Fig 5.2). Treatment of the samples with these inhibitors did not cause cell death as the treated cells responded as well as untreated samples to BCR crosslinking in term of total tyrosine phosphorylation (Fig 5.2). While the PI3K inhibitors suppressed the phosphorylation and activation of Erk MAP kinase, treatment of primary B cells with wortmannin within the same concentration range did not affect the phosphorylation and activation of another intracellular molecule, Vav (Fig 5.3). This indicates that the inhibitory role of these drugs is restricted to the PI3K/Erk pathway. Collectively, these results indicate that PI3K activity is a critical factor associated with the hyper-responsiveness of Lyn -deficient primary B cells. Since the phenotype of the Xid mouse containing a point mutation in the Btk PH domain that disrupts binding to PIP3 is similar to that of p85 α - and p110 δ -deficient mice (Suzuki et al., 1999; Okkenhaug et al., 2002), the possibility that Btk mediates the PI3K-dependent Erk activation was checked in primary B cells from Xid mice. Surprisingly, the BCR-induced Erk activation in Btk-mutated B cell is the same as that of wild-type control and is able to be suppressed by a PI3K inhibitor (Fig 5.4), suggesting an existence of alternative PI3K effector(s) in the Erk pathway.

5.3.2: PI3K kinase activity is enhanced in the lyn -deficient primary B cell

Inhibition of the hyper-sensitive phenotype of Lyn -deficient B cells by PI3K inhibitors prompted us to think that Lyn might negatively regulate PI3K activation and therefore, PI3K activity could be elevated in the absence of Lyn . To verify this possibility, primary B cells from both wild-type and Lyn -deficient mice were left either unstimulated, or stimulated with anti-IgM to activate PI3K inside the cell

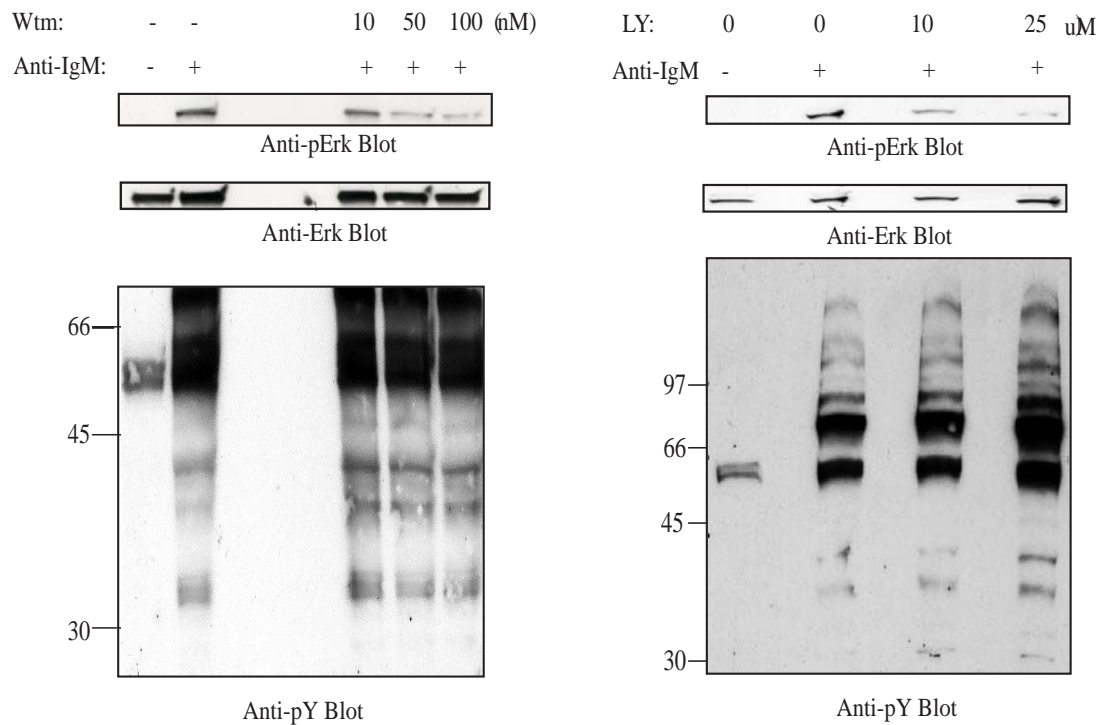

Figure 5.2. Wortmannin and LY294002 have the same inhibitory effect on Erk activation but cause no cell death.

Splenic B cells from wild-type mice were treated with either wortmannin (Wtm) or LY294002 (LY) at increasing concentration before being stimulated with 40 μ g/ml goat anti-mouse IgM. Whole cell lysates were probed with anti-phospho-Erk2 Abs first. The filter was then stripped and re-probed with anti-Erk2, then stripped and re-probed with anti-phosphotyrosine Abs.

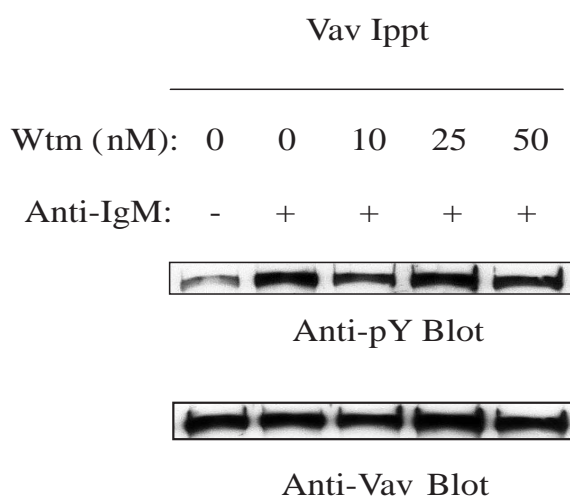

Figure 5.3. Wortmannin does not inhibit the phosphorylation/activation of Vav

Purified splenic B cells from wild type mice were treated with or without Wortmannin at increasing concentration before being stimulated with the F(ab')₂ portion of anti-IgM and lysed with detergent. Vav was immunoprecipitated and checked for its tyrosine phosphorylation using the anti-phosphotyrosine Ab (4G10). The same filter was subsequently stripped and reprobed with rabbit anti-Vav serum to show approximately equal amount of Vav on the filter.

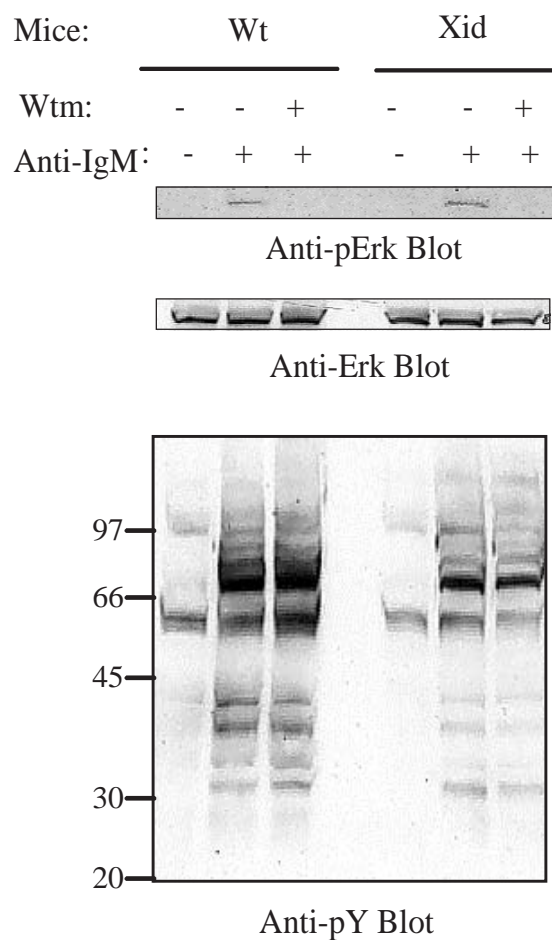

Figure 5.4. PI3K-dependent Erk MAP activation does not require Btk.

Purified splenic B cells from Xid mice and wild type controls were pre-treated with wortmannin at 50nM before being stimulated with goat-anti-IgM and lysed. Whole cell lysates were resolved by SDS-PAGE and probed with Ab recognizing the phosphorylated form of Erk. The filter was then stripped and reprobed with anti-Erk, stripped again and reprobed with anti-phosphotyrosine Abs.

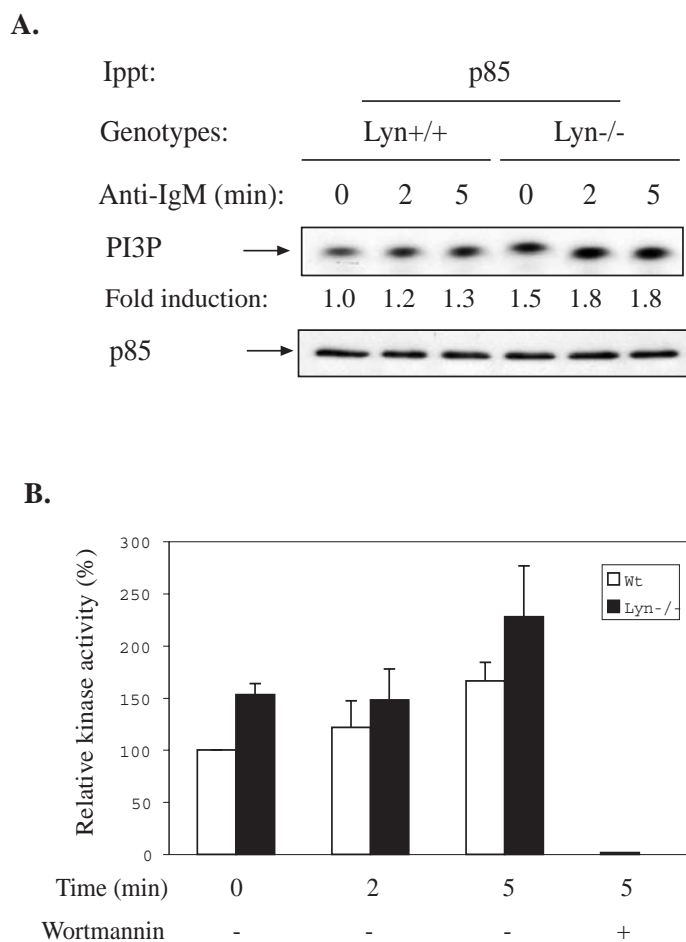

Figure 5.5. *In vitro* PI3K activity is elevated in Lyn -deficient primary B cells

(a.). Purified splenic B cells were incubated with anti-IgM Abs, lysed and the lysates were immunoprecipitated with anti-p85 Ab. Precipitated proteins were then incubated with phosphatidylinositol and [32 P]ATP and separated by TLC. 32 P incorporated into PI3P was quantified using a phosphor imager. (b.). Signals derived from Western blots were scanned over densitometry and the results from three independent experiments are graphed as the relative mean (\pm SEM) quantities of 32 P incorporated into PI3P in all experiments. In each experiment, the kinase activities in unstimulated wild-type B cells were defined as 100%.

before lysis. PI3K was purified by immunoprecipitation using anti-p85 antibody. After addition of phosphatidylinositol (PI), the optimal substrate for PI3K, the enzymatic activity of PI3K was quantitated *in vitro* by the production of PIP3. In wild type samples, 2 min after BCR crosslinking, PI3K activity displayed a slight increase over the 0 min resting status, with a further increase observed 5 min post-stimulation (Fig 5.5). In the Lyn-deficient mice, however, PI3K activity was constitutively higher than that of wild type mice, and showed a further increase after 2 and 5 min BCR-stimulation (Fig. 5.5). These results provide, for the first time, direct evidence that PI3K activity is elevated in primary B cells from Lyn -deficient mice.

5.3.3: PI3K pathway is hyper-active in absence of Lyn

Finding elevated PI3K activity in Lyn -deficient primary B cells predicts that the PI3K pathway should be hyper-active in the absence of Lyn. In agreement with this prediction, Akt, a molecule directly down-stream of PI3K, was reported to be hyper-activated following BCR ligation in Lyn-deficient primary B cells (Li, et al., 1999; Craxton et al., 1999). The hyper-active Akt in the absence of Lyn is further supported here by data showing that BCR-induced Akt activation is reduced in B cells from mice in which Lyn has been mutated to be constitutively active (gain-of-function) (Harder et al., 2001) (Fig 5.6). Complete inhibition of Akt phosphorylation/activation by Wortmannin in both wild-type and Lyn -deficient primary B cells demonstrates the downstream identity of Akt in the PI3K pathway. Compared with wild-type control, while Lyn loss-of-function enhanced Akt activation in response to BCR ligation, the Lyn gain-of-function inhibited Akt activation (Fig 5.6).

The hyper-activity of the PI3K pathway in the absence of Lyn should also lead to the elevated activity of key regulatory molecules further down-stream of PI3K. NF kappa B (NFκB) was recently reported to be a target of the PI3K pathway in mitogen-induced B cell growth (Grumont et al., 2002). An index of NFκB activation is the phosphorylation of the NF-kappa B-bound inhibitory protein IκB, which is degraded once phosphorylated, thereby liberating NF-κB to translocate to the nucleus (Karin and Ben-Neriah, 2000). Therefore, the phosphorylation and degradation of IκBα in

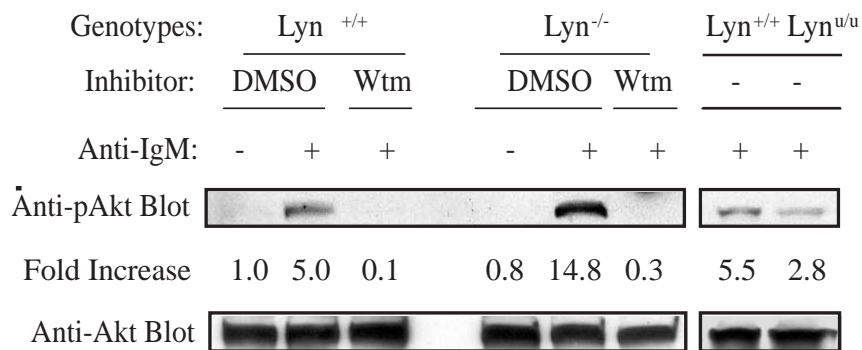

Figure 5.6. PI3K pathway is hyper-active in Lyn-deficient primary B cells--1.

(a) B cells purified from wild-type, Lyn⁻ loss-of-function and Lyn⁻ gain-of-function (lyn^{u/u}) mice were pre-treated with or without wortmannin as indicated before being stimulated with anti-IgM at optimal concentration. Whole cell lysates were probed with antibodies against phospho-Akt. After being stripped, the filter was re-probed with anti-Akt total protein as a loading control.

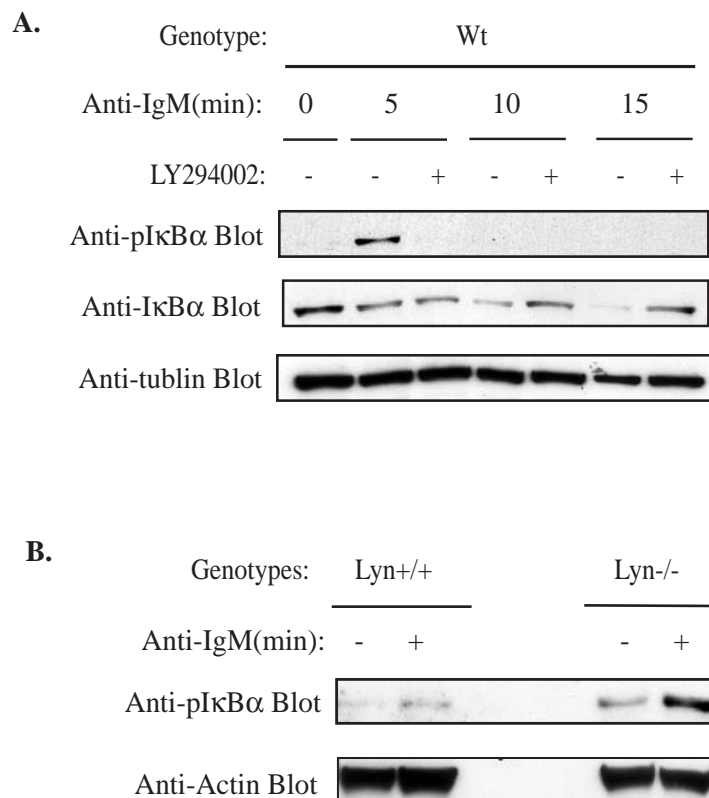

Figure 5.7. PI3K pathway is hyper-active in Lyn-deficient primary B cells--2.

Purified splenic B cells from wild type mice were pre-treated with LY294002 at 25 μ M before stimulation with anti-IgM at different time points as indicated (a), or purified splenic B cells from both wild type and Lyn-deficient mice were stimulated with anti-IgM for 5 min (b). Total cell lysates were probed with antibodies that recognize the phosphorylated form of I κ B α protein. The filters were subsequently stripped and re-probed with either anti-tubulin (a), or anti-actin (b) antibodies as loading controls.

response to BCR stimulation was checked in wild type primary B cells in the presence and absence of PI3K inhibitor. In the LY294002 untreated samples, I κ B α began to be phosphorylated and degraded 5 min after BCR ligation and had disappeared by the 15 min time point. In the presence of LY294002, however, there was no phosphorylation of I κ B α at any time point tested and the protein level of I κ B α also remained constant, even after 15 min post BCR stimulation (Fig 5.7A), confirming a requirement for PI3K in BCR-induced NF κ B activation. This PI3K- dependent signal, however, was found to be much stronger in Lyn -deficient B cells than B cells in wild-type control B cells both before and after BCR ligation (Fig 5.7B), which serves as another piece of evidence for the elevated activity of the PI3K pathway in Lyn -deficient primary B cells.

The hyper-active PI3K pathway in the absence of Lyn was further proven by the phosphorylation status of B Cell Adaptor for PI3K (BCAP) (Okada et al., 2000) in Lyn -deficient primary B cells following BCR ligation. There are four PI3K binding motifs (Y-x-x-M) in BCAP whose tyrosine phosphorylation is greatly increased following BCR ligation (Okada et al., 2000). A BCAP-deficient DT40 B cell line had impaired Akt phosphorylation (Okada et al., 2000; Inabe et al., 2002) while BCAP-deficient primary B cells had reduced calcium mobilization, poor proliferative responses and reduced NF-kappa B activation upon BCR crosslinking (Yamazaki et al., 2002; Yamazaki et al., 2003), indicating an important role of this molecule in PI3K pathway. To check BCAP phosphorylation in the absence of Lyn, BCAP was immunoprecipitated from Lyn -deficient primary B cells after BCR crosslinking and probed with 4G10. Out of the four isoforms of BCAP, the phosphorylation of BCAP 3/4 from Lyn -deficient primary B cells was found to be stronger than in the wild type control sample at the 2 min time point in spite of less protein being present on the gel (Fig 5.8). Collectively, these data demonstrate an elevated activity of PI3K pathway in Lyn -deficient primary B cell.

5.3.4: Lyn inhibits PI3K mediated B cell proliferation

The biochemical pathways regulated by Lyn kinase should finally be represented in B cell functions. One of the important functional consequences of BCR ligation during the response to antigen is proliferation and differentiation into antibody forming

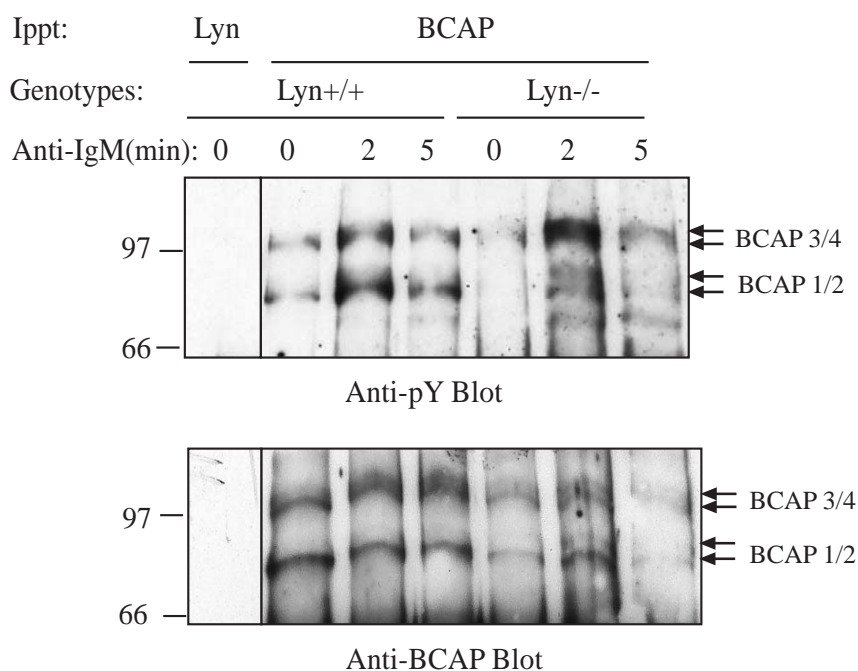

Figure 5.8. BCAP is hyper-phosphorylated in Lyn^{-/-} deficient primary B cells

Purified splenic B cells from both wild-type and Lyn^{-/-} mice were stimulated with F(ab')₂ anti-IgM before lysis and immunoprecipitation of either BCAP, or Lyn as antibody control. After resolution by SDS-PAGE, the proteins were transferred onto a nitrocellulose membrane and probed with anti-phosphotyrosine Ab (upper panel). The membrane was then stripped and re-probed with rabbit anti-BCAP serum (lower panel).

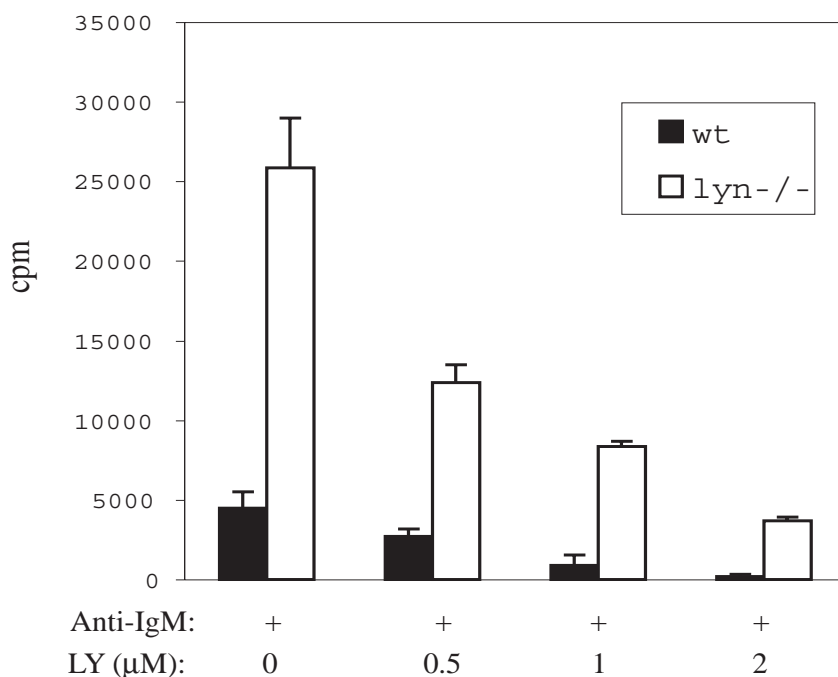

Figure 5.9. The hyper-proliferation of Lyn -deficient B cells is inhibited in a dose-dependent manner by LY29004

Equal number of purified splenic B cells from wild-type and Lyn -deficient mice were stimulated with 1 μg/ml anti-IgM in the presence of increasing concentrations of LY 294002 as indicated, cultured at 37⁰ C for 40 hrs before being pulsed with [³H] thymidine for an additional 6 hours. Incorporation of [³H] is used as a measure of proliferation and is displayed as counts per minute (c.p.m.) for each sample. The graphs represent the average of triplicate wells with s.d. indicated. One of three experiments is shown.

cells. B cells from Lyn -deficient mice hyper-proliferate in response to BCR ligation. Therefore, proliferation of Lyn -deficient B cells was assessed to define the involvement of PI3K in the hyper-proliferative attribute of Lyn -deficient B cells in response to BCR stimulation. Due to the lower rate of degradation of LY294002 in tissue culture conditions it was chosen over Wortmannin to incubate with primary B cell from both wild type and Lyn -deficient mice in the absence and presence of BCR crosslinking reagent. After the 40 hours incubation, ³H-thymidine was added for the last 6 hour. Incorporated radioactivity was measured as count per minute (c.p.m). Noticeably, the B cell proliferation from both wild type and Lyn - deficient mice after BCR ligation was suppressed by PI3K inhibitor in a dose-dependent manner, confirming an essential role for PI3K in B cell proliferation (Suzuki et al., 1999; Jacob et al., 2002). Furthermore, at a certain concentration of inhibitor (2 μ M), the hyper-proliferative property of Lyn -deficient primary B cells was corrected to be equal to that of wild-type uninhibited level (Fig 5.9). This result suggests that PI3K is a major contributor to the hyper-proliferation in Lyn -deficient B cells. Since the activation of Erk MAP kinase is reported to be necessary for mature splenic B cell proliferation (Richard et al., 2001), a similar titration of PI3K inhibitor on Erk phosphorylation/activation was performed on both wild type and Lyn -deficient primary B cells. The inhibition of PI3K activity by wortmannin was monitored by phosphorylation/activation of Akt. Consistent with the proliferation evidence, the hyper-phosphorylated Erk signal from Lyn-deficient mice after BCR crosslinking was inhibited by wortmannin in a dose-dependent manner as was Akt phosphorylation (Fig 5.10). At a certain concentration of the drug (approximately 12nM), the phosphorylation of Erk in Lyn -deficient samples was reduced to be equal to that in wild-type untreated B cells (Fig 5.10).

5.3.5: Src family kinases are involved in PI3K activation in primary B cell

The dose-dependent effect of PI3K activity on the Lyn -deficient phenotype and the elevated PI3K activity in the absence of Lyn strongly suggest that lyn inhibits the activity of PI3K itself, not just its down-stream molecules, such as Akt. But what causes PI3K activation in primary B cells? Since the SH3 domains of Lyn and Fyn

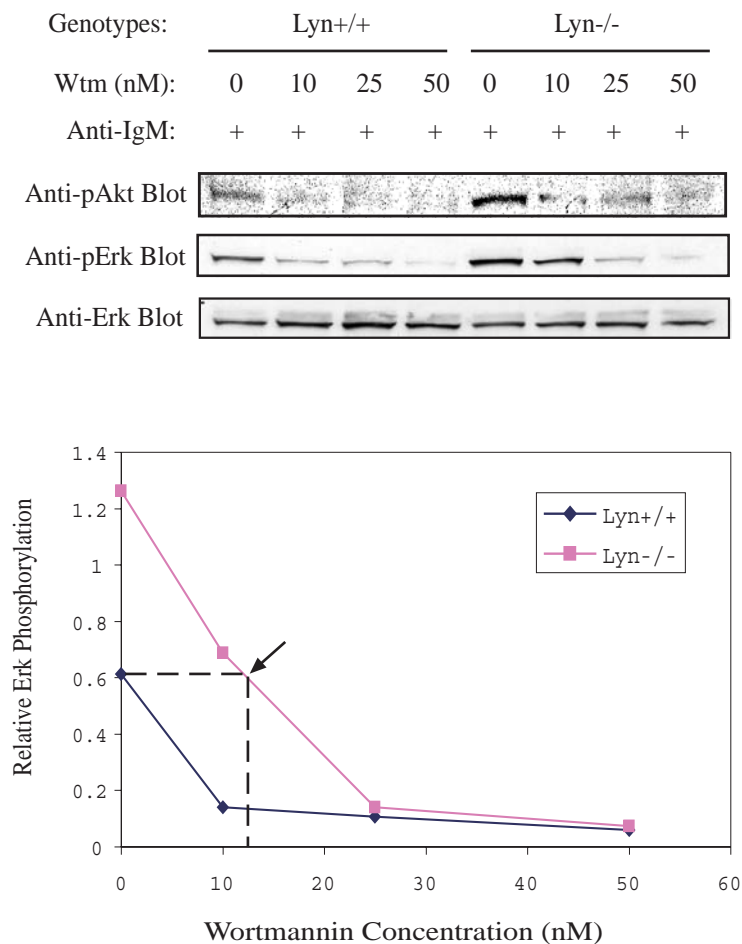

Figure 5.10. Elevated Erk MAP kinase activation in Lyn -deficient primary B cells after BCR ligation is inhibited by wortmannin in a dose-dependent manner

Splenic B cells from both wild-type and Lyn -deficient mice were treated with either DMSO or increasing concentration of wortmannin before stimulation with 40 μ g/ml F(ab')₂ goat anti-mouse IgM. Whole cell lysates were probed with anti-phospho-Akt and anti-phospho-Erk2 Abs. The filter was stripped and re-probed with anti-Erk2 (upper panel). Signals obtained from the Western blots were quantified by densitometry and the relative phosphorylation of Erk over total Erk was plotted (lower panel). Arrow indicates the concentration of drug required to inhibit the hyperphosphorylation of Erk from Lyn -deficient sample to be equal to that in wild-type untreated sample.

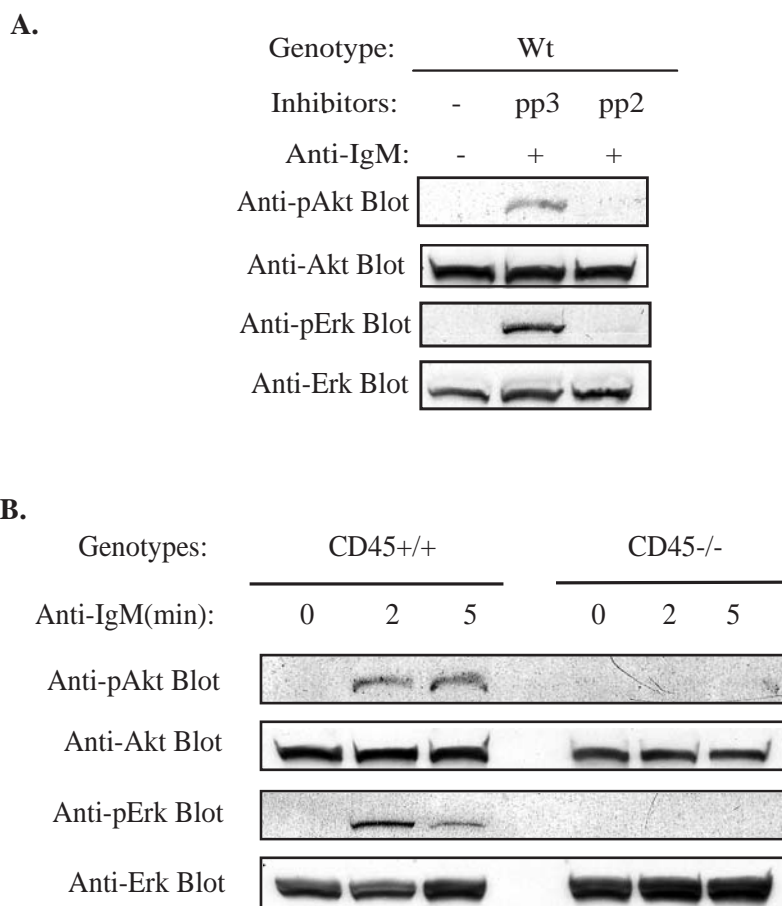

Figure 5.11. Src family kinases are involved in PI3K activation

(a.) Purified splenic B cells from wild type mice were treated either with 10 μ M pp3 or pp2 at 37 $^{\circ}$ C before stimulation with F(ab')₂ anti-IgM for 2 min and then lysed. The whole cell lysates were checked for phosphorylated forms of Akt and Erk, and then the filter was stripped and re-probed with anti-Akt and anti-Erk Abs as loading controls. (b.) Purified primary B cells from wild type and CD45-deficient mice were stimulated and whole cell lysates were probed as in (a).

were reported to activate the specific kinase activity of PI3K by five to seven-fold *in vitro* (Pleiman et al., 1994), we used pp2, a specific SFK inhibitor (Hanke et al., 1996), to check the requirement for SFK activity in PI3K activation in wild-type primary B cells, using Akt phosphorylation as a readout. After BCR ligation, Akt was phosphorylated in the samples treated with pp3, a control drug for pp2, but not in samples treated with pp2, indicating a requirement of SFK activity in the activation of PI3K. Additionally, Erk phosphorylation was also found to be greatly reduced in the pp2 treated primary B cells, which agrees with the PI3K-dependence of Erk MAP kinase activation (Fig 5.11A). Consistent with the pharmaceutical results, Akt activation in response to BCR ligation was found to be abolished in primary B cells from CD45-deficient mice, in which the phosphatase CD45, believed to be the SFK activator (Yanagi et al., 1996), was absent. Furthermore, like pp2 treated samples, Erk MAP kinase activation in response to BCR crosslinking at different time points was not observed (Fig 5.11C).

5.3.6: Other Src PTKs contribute to the elevated PI3K activity in Lyn-deficient primary B cells

Having shown that SFKs are responsible for PI3K activation in presence of Lyn, we next asked if it was still the case when Lyn, the major SFK expressed in B cell, was absent. In other words, are other SFKs involved in the elevated PI3K activity in Lyn-deficient primary B cells? To answer this question, we treated primary B cells from both wild-type and Lyn-deficient mice with increasing concentrations of pp2 before BCR ligation and then examined Akt phosphorylation. In wild type mice, BCR-induced Akt activation was brought down by pp2 in an apparently dose-dependent manner, with significant reduction at 2 μ M, and abolition at 10 μ M pp2, confirming the involvement of SFKs in PI3K activation in wild-type B cells. In the Lyn-deficient B cells, the hyper-activated Akt activity following BCR ligation was also successfully suppressed by increasing concentration of the SFK inhibitor. Although not completely abolished at 10 μ M, the level of induced phospho-Akt signal from Lyn-deficient primary B cells disappeared at 20 μ M concentration of pp2 (Fig 5.12). Since the activation of SFKs precedes the activation of Syk by several minutes following BCR ligation (Yamanashi et al., 1992; Burg et al., 1994) and Syk is believed to require SFKs for full activation (Kurosaki et al., 1994),

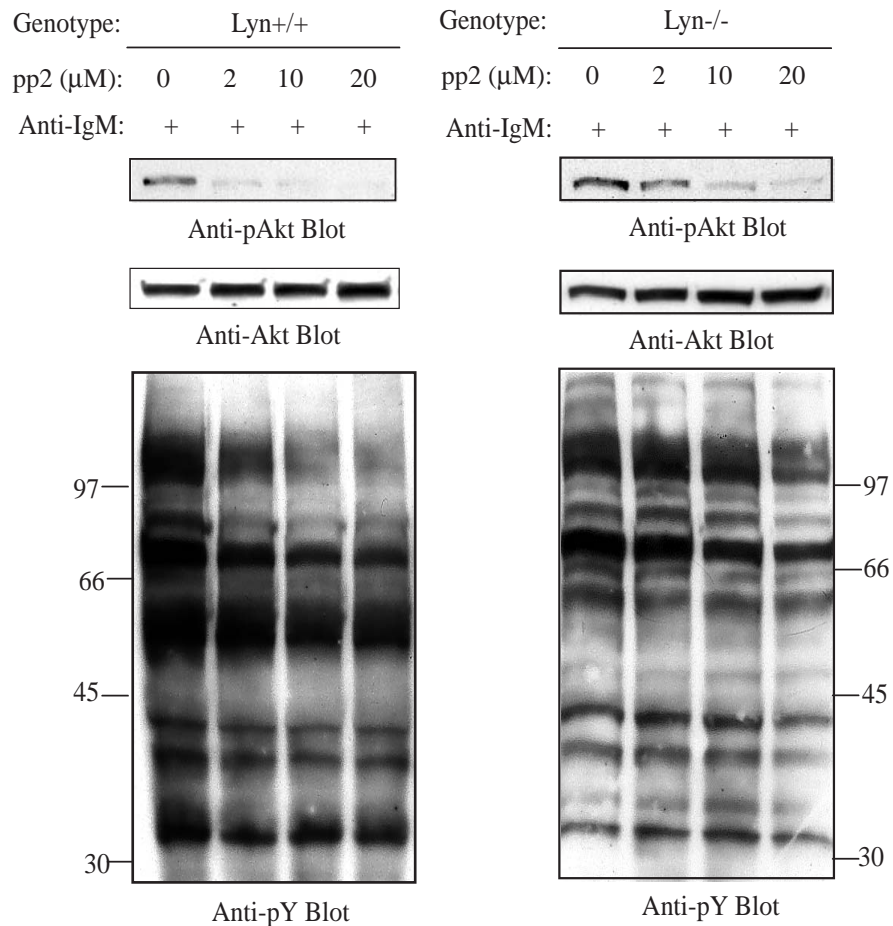

Figure 5.12. Other Src PTKs contributes to the elevated PI3K activity in Lyn-deficient primary B cells.

Purified splenic B cells from both wild type and Lyn-deficient mice were treated either with DMSO or pp2 at increasing concentrations before stimulation with F(ab')₂ anti-IgM, followed by lysis. Whole cell lysates were probed for the phosphorylated form of Akt. The filters were subsequently stripped and probed with anti-Akt and anti-phosphotyrosine antibodies.

it was important to prove that the concentration of Src inhibitor used in our experiment did not affect the activity of Syk. Because Syk is the critical protein tyrosine kinase involved in phosphorylation of the majority of signalling molecules inside B cells, if Syk activity had been inhibited in the pp2 treated samples, the tyrosine phosphorylation of the whole cell lysates in response to BCR stimulation would be greatly reduced, as was reported in the Syk-deficient A20 B cell line (Yokozeki et al., 2003). We therefore examined total tyrosine phosphorylation of the pp2 treated samples. With the increasing concentration of pp2 on both wild type and Lyn -deficient primary B cells, the total tyrosine phosphorylation was reduced only slightly (Fig 5.12), suggesting normal Syk activity in the drug-treated samples. The fact that the hyper-phosphorylation of Akt in BCR stimulated lyn -deficient B cells was suppressed by pp2 as it was in wild-type controls indicates that SFKs other than Lyn are responsible for PI3K activation in Lyn-deficient primary B cells.

But what is the link between the SFKs and PI3K activation and how does Lyn inhibit PI3K activity? The phosphorylation events catalysed by PTKs not only modulate the catalytic activity of effector enzymes but also mediate protein-protein interactions that juxtapose critical signal transduction elements. Since PI3K activity requires PI3K to be recruited close to its substrate in the plasma membrane by membrane bound proteins that contain the pY-x-x-M motif, SFK might affect PI3K activity via tyrosine phosphorylation of these PI3K recruiting proteins. To investigate this possibility, we stimulated primary B cells from wild-type mice, immunoprecipitated the p85 subunit of PI3K and probed with anti-phosphotyrosine antibody to see if any PI3K associated protein become phosphorylated in response to BCR ligation. In the 4G10 blot, we noticed a BCR-induced tyrosine phosphorylated band that migrated at a position above 97kD in the p85 immunoprecipitates. The phosphorylation of this protein increases 2 min following BCR crosslinking and declines at 5 min post-stimulation (Fig 5.13A). According to its molecular weight it is not the p85 subunit of PI3K (Fig 5.13A lower panel), nor is p110 catalytic subunit of PI3K (110kD). Probing the same filter with anti-CD19 antibody proved that it is not CD19 either. The BCR-induced tyrosine phosphorylation of this PI3K associated protein, however, is inhibited by pp2 (Fig 5.13B), suggesting it is either a substrate of SFK or a

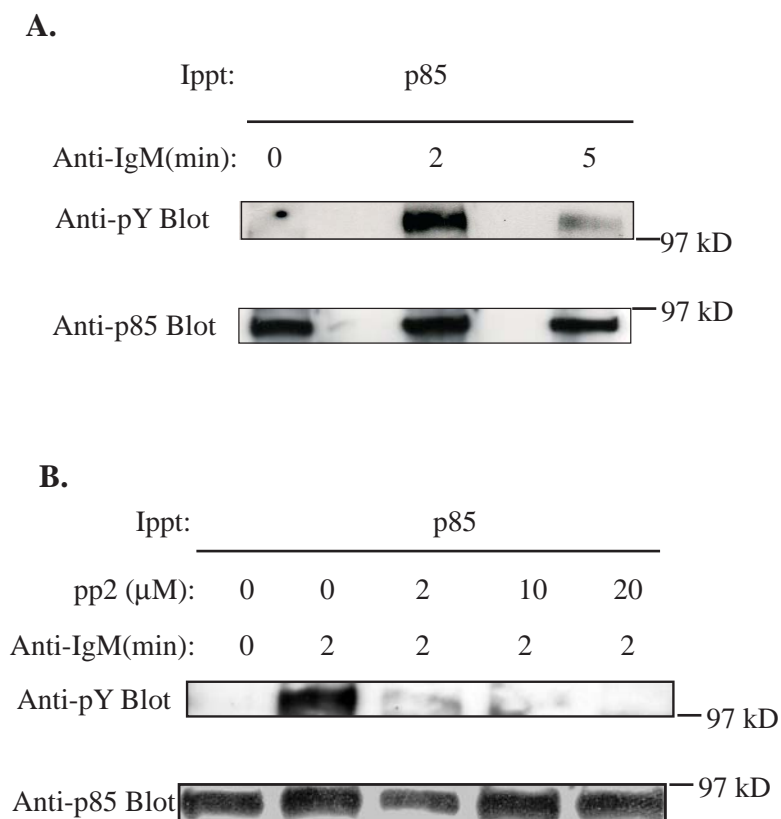

Figure 5.13. The PI3K associated protein is the substrate of Src PTKs.

(a). Purified splenic B cells from wild-type mice were stimulated with F(ab') anti-IgM and lysed. p85 was immunoprecipitated and the tyrosine phosphorylated proteins that associated with p85 (upper panel) were detected with anti-pY Ab. The filter were subsequently stripped and re-probed with rabbit anti- p85 serum as a loading control (lower panel). (b). Purified splenic B cells from wild-type mice were treated with pp2 at increasing concentration as indicated and then proceeded as in (a).

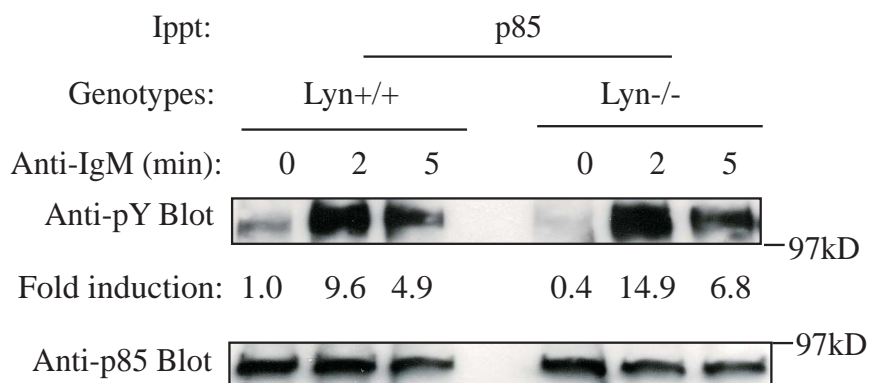

Figure 5.14. A PI3K associated protein is hyper-phosphorylated in the absence of lyn. *lyn*^{+/+} or *lyn*^{-/-} splenic B cells were stimulated with anti-IgM for the time indicated and then lysed. p85 was immunoprecipitated and tyrosine phosphorylated proteins associated with p85 (upper panel) and immunoprecipitated p85 (lower panel) were detected with anti-pY and p85 antibodies respectively. Fold induction is calculated as relative signal over wild type unstimulated control after normalised for the amount of p85 precipitated.

molecule whose tyrosine phosphorylation is controlled by SFK. Consistent with the elevated PI3K activity in *Lyn*-deficient primary B cells, the SFK-dependent tyrosine phosphorylation of this protein(s) is also enhanced in *Lyn*-deficient B cells following BCR ligation compared with that of wild-type control (Fig 5.14). Therefore it is possible that *Lyn* down-regulates PI3K activity by either inhibiting other SFKs activity or de-phosphorylating these PI3K-recruiting molecules via tyrosine phosphatases.

5.4. DISCUSSION

In this study, we demonstrate the novel finding that the BCR hyper-sensitive phenotype of primary B cells from *Lyn*-deficient mice is attenuated by removal of PI3K activity, suggesting a negative regulatory role for *Lyn* in the PI3K pathway. PI3Ks are a family of enzymes that regulate diverse biological functions in every cell type by generating lipid second messengers (Vanhaesebroeck et al., 2001). New insights into the role of PI3Ks in lymphocyte biology have been derived from recent gene-targeting studies, which reveal an important regulatory role for this lipid kinase in adaptive immunity including cell growth, differentiation, survival, and proliferation. Too little PI3K activity leads to immunodeficiency, whereas too much activity leads to autoimmunity and leukaemia (Fruman et al., 1999; Suzuki et al., 1999; Jou et al., 2002; Borlado et al., 2000). Given such an essential role for PI3K in the immune system, it is not surprising to find that PI3Ks or their pathways are targets of negative regulatory molecules such as *Lyn* in primary B cells.

Although the signalling cascades involving Ras, PI3K and PLC- γ activated in response to BCR ligation are generally described as independent of each other, cross-talk between these pathways is essential for actual signalling transduction inside the cells and PI3K seems to be dominant over the other two. For example, PI3K activity was reported to be required for the activation of Ras/MAPK pathway in several cell lineages including B cell (Von Willebrand et al., 1996; Lopez-Illasaca et al., 1997; Wennstrom et al., 1999; Jacob et al., 2002). Likewise, assembly of PH-domain containing, membrane-associated signalling complex including PLC- γ and tyrosine

kinase Btk, which finally results in intracellular calcium flux, requires PIP3, the product of PI3K (Vanhaesebroeck et al., 1997). A B cell adaptor molecules of 32 kDa (Bam32) has also been found to have a high affinity PIP3-binding PH domain and seems to have a role in BCR-dependent calcium flux, although the mechanism by which this occurs is unknown (Marshall et al., 2000; Niiro et al., 2002). Consistent with this biochemical evidence, the hallmark of the B cell phenotype from conditional PI3K-deficient mice is reduced proliferation in response to mitogen stimulation including BCR ligation (Suzuki et al., 1999; Fruman et al., 1999). Furthermore, the proliferation of B cells was shown to be controlled by PI3K-dependent induction of Rel/NF-kappaB regulated c-myc transcription (Grumont et al., 2002).

Since PI3K activity is required in wild type primary B cells for the activation of Erk MAPK, calcium flux and proliferation in response to BCR ligation, the inhibition of these elevated properties in Lyn -deficient B cell by PI3K inhibitors could simply reflect that PI3K is upstream of these pathways in which Lyn has an individual inhibitory role. However, we excluded this possibility by showing the dose-dependent effect of PI3K inhibitors on dampening Erk activation and proliferation in Lyn-deficient primary B cells in response to BCR ligation. In addition, direct *in vitro* PI3K kinase activity assay in Lyn- deficient primary B cells further confirm the inhibition of PI3K activity by Lyn in primary B cell.

In this study, we further demonstrated that SFK activity is required for the elevated PI3K activity in Lyn deficient primary B cells as the elevated PI3K activity, represented by the stronger Akt phosphorylation, in the Lyn -deficient primary B cells could be suppressed by the SFK inhibitor pp2 in a dose-dependent manner. The increasing concentration of pp2 used did not appear to affect Syk activity as total tyrosine phosphorylation blots demonstrated extensive tyrosine phosphorylation in response to BCR stimulation after the pp2 treatment. Consistent with our data, two groups recently reported that BCR-mediated activation of PI3K and MAP kinase is Syk-independent (Yokozeki et al., 2003), and SFK-dependent NF kappaB activation in pro-B cell does not require Syk (Saijo et al., 2003). Therefore, our data suggest that the mediators of this elevated PI3K activity in the absence of Lyn are the other SFKs. Furthermore, SFK dependent phosphorylation of a PI3K associated protein

was found to be enhanced following BCR ligation in the Lyn⁻deficient B cells, suggesting a counter-balancing role for Lyn with the other SFKs in PI3K activation. In agreement with this hypothesis, Fyn-mediated, PI3K-dependent mast cell degranulation is reported to be elevated in the Lyn⁻deficient mice (Parravicini et al., 2002).

What then are the mechanisms that underlie the inhibition of SFK activity by Lyn? The activity of SFKs can be regulated by phosphorylation of C terminal Tyr527 by Csk, which mediates an intramolecular association with the SH2 domain of the same kinase, and therefore leads to repressed kinase activity (Cooper and Howell 1993). Data that are emerging from several laboratories indicate that the newly identified membrane adaptor molecule that has affinity for lipid rafts, PAG/cbp (phosphoprotein associated with glycosphingolipid-enriched microdomains/Csk binding protein), might regulate Csk subcellular localization (Kawabuchi, et al., 2000; Brdicka et al., 2000). PAG/cbp is expressed in mast cells, T cells and B cells (Kurosaki et al., 2002) and once phosphorylated in mast cells and T cells, has been shown to recruit Csk from the cytoplasm to the lipid rafts for termination of SFK activity (Ohtake et al., 2002; Davidson et al., 2003). The protein tyrosine kinase responsible for PAG/cbp phosphorylation in B cells might be Lyn because Lyn is the predominant Src PTK in B cells (Yamanashi et al., 1989; Yamanashi et al., 1991) and located in the lipid raft (Casey et al., 1995; Cheng et al., 1999). Thus, Lyn that is activated following BCR ligation could initiate a negative - feedback regulatory loop to control SFKs activity - including its own-by phosphorylating PAG. In the absence of Lyn, this negative regulatory loop would be lost or diminished and dysregulated SFK activity could occur.

Another mechanism by which Lyn could inhibit the activation of other SFKs is via the SH2 domain-containing protein tyrosine phosphatase SHP-1, which links the already established mechanism of negative regulation by Lyn (Chan et al., 1997; Chan et al., 1998; Smith et al., 1998; Hibbs et al., 2002) to our present findings. For SHP-1 activation, its tandem SH2 domains need to be associated with a tyrosine-phosphorylated peptide (Pei et al., 1994). Upon BCR ligation, SHP-1 is recruited to

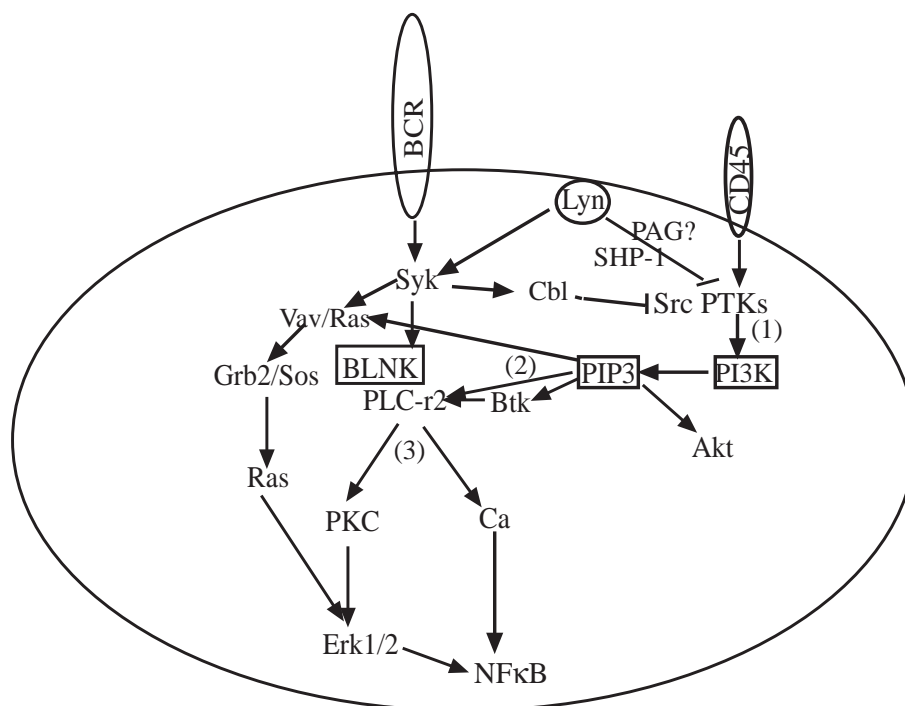

Figure 5.15. Proposed model for inhibition of PI3K activation by Lyn in the context of BCR signalling.

(1) PI3K is rapidly activated after BCR cross-linking via adaptor molecules for membrane recruitment and then via SFKs for the lipid kinase activation. (2) Activated PI3K produce PIP3 to attract and activate PH-domain containing molecules, (3) leading to MAP kinase and calcium activation. The up-stream inhibition of PI3K by Lyn potentially involves both de-phosphorylation of PI3K adaptor molecules and down-regulation of Src PTKs activation. The mechanisms could be through adaptor molecules such as PAG, tyrosine phosphatases like SHP-1 or the ubiquitin ligase Cbl.

the plasma membrane via binding to phosphorylated tyrosine residues within Immunoreceptor Tyrosine-based Inhibitory Motifs (ITIMs) of several B cell surface molecules such as CD22, FcγRIIb, and CD72. This recruitment of SHP-1 requires Lyn as tyrosine phosphorylation within the ITIMs of these surface molecules depends on the presence of Lyn. In line with the positive role of Lyn in activation of SHP-1, SHP-1 phosphorylation in response to BCR crosslinking was found to be reduced in Lyn loss-of-function mice (Nishizumi et al., 1998; Hibbs et al., 2002) and enhanced in Lyn gain-of-function mice (Hibbs et al., 2002). Conversely, activated SHP-1 was found to deactivate Src family Lyn, as cyanogen bromide cleavage data revealed that SHP-1 de-phosphorylates the Lyn auto-phosphorylation site (Somani et al., 2001). Given the sequence homology among the Src family PTKs in the autophosphorylation site, this role of SHP-1 in dephosphorylating/deactivating Lyn could equally well be extended to other Src PTKs. Therefore, in the wild-type situation, Lyn seems to be involved in activating SHP-1, which in turn terminates the activity of whole Src PTKs including Lyn itself. In the absence of Lyn, however, the activation of SHP-1 is diminished, which then causes the hyper-active state of other SFKs in B cells.

Apart from PAG/cbp and PTP, the other candidate molecule that Lyn may work on to inhibit SFK activation is Syk. Lyn was reported to be responsible for the phosphorylation of inhibitory Tyr-317 within the linker region of Syk, which recruits Cbl to dampen the calcium signal in DT40 B cells (Hong et al., 2002). The Cbl family of proteins contain substrate recognition domains that interact specifically with the SH3 domain of SFKs (Tsygankov et al., 2001) and therefore, targets activated Src kinases for degradation thus attenuating receptor signalling (Rao et al., 2002). Along this line, the Lyn protein expression level from primary B cells, in which Lyn was genetically manipulated to be constitutively active, was much less than that of wild type control (Hibbs et al., 2002). Furthermore, several groups have demonstrated recently that Cbl polyubiquitinates activated pools of Fyn, Lck and Src, leading to their proteasomal degradation (Yokouchi et al., 2001; Rao et al., 2002). Moreover, Cbl-deficient cells showed reduced levels of Fyn and Lck ubiquitination, indicating an important role for endogenous Cbl in regulating SFK turnover (Rao et al., 2002). Given such an important role of Cbl in down-regulating SFK activity, it would then

be possible that reduced degradation of SFKs by low recruitment of Cbl in absence of Lyn causes the elevated PI3K activity.

In spite of the several mechanisms that could lead to the enhanced activity of SFKs in the absence of Lyn, our data demonstrate convincingly a negative regulatory role of Lyn in PI3K activation. Lyn could have achieved this effect by any of the above-mentioned mechanisms in primary B cells, acting alone or in combination. Our proposed model is that in resting B cells, signalling molecules are sporadically distributed in the plasma and cell membrane compartments. Co-ligation of oligomeric BCR by antigen activates SFKs, which initiates BCR signal transduction via activating PI3K in addition to phosphorylating Ig α / β . Activated PI3K produces the lipid product PIP3 to recruit PH domain-containing molecules such as PLC- γ , Btk, Vav, and Akt, to the plasma membrane. Recruitment of these positive molecules to the plasma membrane brings them in to close proximity of the lipid rafts where many signal activating enzymes reside. Once activated, these molecules then catalyse reaction cascades in the PLC- γ pathway, the Ras/MAPK pathway, and the Akt pathway, which will finally lead to the activation of such transcription factors as NF- κ B and NFAT. At the same time as antigen initiates BCR signalling, it also starts negative feed-back machinery inside the cell, presumably to counter-balance the positive signalling promoted. Work presented in this chapter and previously published data indicate that the task of this negative regulatory role in BCR signalling is mainly Lyn's. After activation together with other SFKs by BCR ligation, Lyn could phosphorylate ITIM containing surface molecules to recruit SHP-1 close to membrane-located SFKs for down-regulation of their activities. In addition, Lyn might phosphorylate the membrane adaptor protein PAG/cbp, which then recruits Csk to lipid rafts for de-activation of SFKs. Finally Lyn might phosphorylate a particular tyrosine in Syk to recruit Cbl for the degradation of already activated SFKs. Exactly which mechanism is involved in the down-regulation of the various signalling pathway following BCR ligation remains to be clarified, but it is clear that Lyn can participate in all. We are currently investigating these mechanisms within primary B cells.

CHAPTER 6: GENERAL DISCUSSION

6.1: INTRODUCTION

The intracellular signalling cascades triggered by the B-cell antigen receptor (BCR) determine the fate of B lymphocyte during both development and immune responses. Depending upon whether suitable signals are obtained from other cell types in different contexts, ligation of the BCR by antigen can have different outcomes including proliferation, differentiation, functional inactivation and apoptosis (Nossal, 1983; Healy and Goodnow, 1998). Such BCR signalling, however, is balanced or fine tuned by surface molecules that perceive the situation under which the B cell contacts antigen as well as intracellular enzymes that control the signal transduction cascades. For example, tyrosine phosphorylation of CD19 cytoplasmic tail, caused by binding of complement-coated antigen to BCR, recruits and activates the lipid kinase PI3K and the effector molecule Vav, both of which enhance BCR signalling (Tuveson et al., 1993; Weng et al., 1994). Co-ligation of Fc γ receptor IIB with BCR on the B cell via the Fc portion of IgG bound to antigen in the later stages of an immune response causes tyrosine phosphorylation of the cytoplasmic domain of Fc γ receptor IIB, which then recruits and activates the inositol phosphatase SHIP to terminate the antigenic response (Ono et al., 1996; Kiener et al., 1997). Altering the balanced of BCR signalling could lead to either immunodeficiency or autoimmunity. In this thesis, the roles of Lyn, a non-receptor protein tyrosine kinase (PTK) of the Src family, in the regulation of both positive and negative BCR signalling pathways were investigated and novel mechanisms were proposed.

6.2: DISCUSSION

6.2.1: The Role of Lyn in Positive Regulation of BCR Signalling

Lyn is the predominant Src PTK expressed in B cells and has been implicated by a variety of biochemical experiments to be involved in BCR signal propagation. Lyn associates with IgM and IgD complexes (Yamanashi et al., 1991) and is rapidly phosphorylated and activated upon BCR cross-linking (Burkhardt et al., 1991). Furthermore, the activation of Lyn correlates with the tyrosine phosphorylation of Ig α / β (Saouaf et al., 1994). In addition, Lyn interacts with and phosphorylates tyrosine residues in a number of intracellular signalling effector molecules in BCR pathway such as Syk kinase (Kurosaki et al., 1994; Sidorenko et al., 1995), HS1 protein (Yamanashi et al., 1993; Yamanashi et al., 1997) and the Cbl protooncogene product (Tezuka et al., 1996) following BCR ligation. The positive function of Lyn in BCR was first demonstrated in a Lyn-deficient variant of the chicken B cell line DT40, which exhibited delayed calcium influx following BCR ligation (Takata et al., 1994), indicating a requirement for Lyn in promoting BCR-induced calcium mobilization. Consistent with these cell line data, Lyn-deficient mice that were generated later also demonstrated a hypo-proliferation phenotype in primary B cell following BCR ligation (Hibbs et al., 1995; Nishizumi et al., 1995). A positive role for Lyn in BCR-induced signal transduction is further supported by the development of autoimmune disease in the recently generated gain-of-function Lyn mutant mice (Harder et al., 2001; Hibbs et al., 2002). Consistent with the positive role of Lyn in initiating BCR, delay is observed in tyrosine phosphorylation of total cellular proteins following BCR ligation in the absence of Lyn (Chan et al., 1997; Fig 3.1).

While the promotional effect of Lyn on BCR signalling was obvious in these studies, the question of whether this activity was unique to Lyn remained unanswered, because there are deficiencies in the approaches used above. For example, Lyn is the only Src family PTK expressed in the DT40 cell line, Lyn-deficient mice develop autoimmune disease as they age and in the Lyn gain-of-function mice, Lyn is active in resting cells when the protein kinases are supposed to remain in a quiescent state, which might result in different signalling mechanism from that in activated cells. It was later found that Lyn-deficient DT40 chicken B cells that express other Src-family kinase members had BCR signalling reconstituted (Takata et al., 1994); that BCR

stimulation of Lyn-deficient B cell from mouse spleen at sub-optimal concentrations led to enhanced proliferation (Wang et al., 1996; Chan et al., 1997); and that the Lyn gain-of-function primary B cell also displayed enhanced phosphorylation of negative regulatory molecules such as CD22 and SHP-1 (Hibbs et al., 2002). Collectively, these data suggest that the role of Lyn in amplifying BCR is conditional and replaceable. In the absence of Lyn, the tyrosine phosphorylation of Ig α / β in the BCR complex, which is an important event in recruiting and activating the critical molecule Syk, could still be achieved (Chan et al., 1997; Cornall et al., 1998).

Besides the BCR complex, Lyn was also reported to physically associate with CD19 (van Noesel et al., 1993), making it possible that the positive mechanisms of Lyn in regulating BCR could be achieved by phosphorylating CD19, a BCR co-stimulatory molecule. Indeed, Tedder's group has recently reported that tyrosine phosphorylation of CD19 is abolished in Lyn-deficient primary B cell (Fujimoto et al., 2000). There are nine conserved tyrosine residues in the ~240-amino acid cytoplasmic region of CD19 (Tedder et al., 1989), which mediates most of the functions of CD19 except the induction of homotypic cellular aggregation (Matsumoto et al., 1993). If Lyn is the only PTK that phosphorylates CD19, the phenotype of Lyn-deficient primary B cells should overlap to same extent with that of CD19-deficient B cell. Rather the two are obviously and almost diametrically different (Hibbs et al., 1995; Nishizumi et al., 1995; Richert et al., 1995; Engel et al., 1995). Furthermore, the phenotype of Lyn- and CD19- double deficient primary B cell should look like that of Lyn- deficient primary B cell rather than that of CD19-deficiency in that the double mutation suppressed the hyper-responsiveness and development of autoimmunity characteristic of Lyn-deficient mice (Hasegawa et al., 2001).

For these reasons, the role of Lyn in phosphorylation of CD19 was re-examined. Lyn was found to be weakly associated with CD19 since it required the use of mild detergent. Furthermore, the weak association of Lyn with CD19 is constitutive and the BCR-induced phosphorylation of CD19 did not cause "processive binding" of Lyn to CD19 as was proposed by Tedder's group (Fujimoto et al., 2000). However, constitutively active Lyn did result in CD19 phosphorylation in resting B cells and this constitutive phosphorylation was increased following BCR ligation, suggesting

that Lyn phosphorylates CD19 when it is active. It is interesting to speculate that the constitutive phosphorylation of CD19 in Lyn gain-of-function mice may be part of the biochemical basis for the autoimmunity observed in such mice (Hibbs et al., 2002). However, BCR-induced CD19 phosphorylation was not affected by loss of Lyn. In agreement with its phosphorylation, the functions of CD19 in recruiting PI3K, elevating calcium flux, and increasing MAP kinase activity also turned out to be intact in the absence of Lyn (Chapter 4). Collectively, these data suggested that the role of Lyn in phosphorylating CD19, like that in phosphorylation of ITAM-containing molecules $Ig\alpha/\beta$ in the BCR complex, is redundant.

6.2.2: The Positive Roles of CD19 in BCR Signalling

CD19 is an essential co-receptor for the BCR and co-ligation of the BCR with CD19 reduced the degree of ligation of the BCR required for full B cell activation (Cater and Fearon, 1992). In CD19-deficient mice, peritoneal B-1 lineage cells are greatly reduced (Richert et al., 1995; Engel et al., 1995). CD19 deficiency was also reported to result in the severe reduction of serum Ig levels and diminished T-dependent immune response (Sato et al., 1996; Sato et al., 1997). Biochemically, the nine conserved tyrosine residues (Tedder et al., 1989) in the 240-amino acid cytoplasmic region of CD19 become rapidly phosphorylated following BCR ligation to generate functionally active SH2-recognition domains that mediate the recruitment of regulatory molecules to the plasma membrane such as Vav and PI3K (Tuveson et al., 1993) for the generation of inositol-1,4,5-trisphosphate and elevation of intracellular calcium concentration (O'Rourke et al., 1998). Ligation of CD19 or co-ligation of the BCR and CD19 also results in activation of three mitogen-activated protein kinases, Erk2, JNK and p38 (Weng et al., 1994; Tooze et al., 1997; Li and Carter, 1998; O'Rourke et al., 1998). Recently BCR-induced tyrosine phosphorylation of $Ig\alpha$ and Lyn but not Syk was found to be greatly compromised in CD19-deficient primary B cells while phosphorylation of $Ig\beta$ and Fyn was abolished (Fujimoto et al., 1999a), suggesting a reduced activity of Src family PTK in the absence of CD19. A novel role of CD19 in the amplification of Src PTK Lyn activity following BCR ligation was proposed (Fujimoto et al., 1999a; Fujimoto et al., 2000). However, since the role

of Lyn in initiating BCR signalling is known to be redundant (Chan et al., 1997; Cornall et al., 1998) while its role in negative signalling pathways is unique (Wang et al., 1996; Chan et al., 1997; Chan et al., 1998; Cornall et al., 1998; Smith et al., 1998), it seems paradoxical that CD19 can promote BCR signalling via amplifying Lyn. Contrary to the published report, we found that the unique functions of Lyn in dampening BCR via CD22 and Fc γ RIIB were independent of CD19 and the activity of Lyn is normal in the CD19-deficient B cells both before and after BCR ligation (Chapter 4). Although it remains possible that CD19 amplifies other Src family PTKs to phosphorylate Ig α / β for the propagation of BCR signalling, we conclude that CD19 has no effect on the functions of Lyn after BCR ligation. The roles of Lyn and CD19 appear therefore to be independent and opposing, one being primarily inhibitory and the other stimulatory.

6.2.3: Negative Regulation of BCR Signalling by Lyn

Since the generation of Lyn-deficient mice and their subsequent development of autoimmune disease (Hibbs et al., 1995; Nishizumi et al., 1995), accumulating evidence has indicated a negative role for Lyn in regulating BCR signalling. Although Lyn-deficient mice have a reduced number of B cells, this deficiency is mainly confined to mature recirculating population and is probably caused by the accelerated differentiation of B cells into antibody forming cell (Chan et al., 1998) rather than a developmental block. In vitro experiments showed that besides hyper-proliferation in response to BCR cross-linking at lower concentration (Wang et al., 1996; Chan et al., 1997), Lyn-deficient primary B cells also showed elevated MAP kinase activation (Chan et al., 1997; Chan et al., 1998) and enhanced calcium flux (Chan et al., 1998; 1998; Cornall et al., 1998; Nishizumi et al., Smith et al., 1998). The mechanisms proposed so far to explain the hyper-sensitive phenotype of Lyn-deficient B cells, however, are limited to the defective phosphorylation of CD22 (Chan et al., 1998; Cornall et al., 1998; Nishizumi et al., 1998; Smith et al., 1998), CD72 (Adachi et al., 1998) and PIR-B (Ho et al., 1999) with the subsequent failure to recruit the tyrosine phosphatase SHP-1 and the reduced phosphorylation of Fc γ RIIB (Chan et al., 1998; Nishizumi et al., 1998) and its subsequent inability to recruit the phospholipidase SHIP (Sarmay et al., 1997; Chan et al., 1998; Nishizumi et al., 1998).

Apart from protein-protein interactions, lipid-protein interactions also play an important role in receptor-induced signalling. The recently generated conditional mutant mice for PI3K demonstrated the indispensability of this lipid kinase in BCR-induced proliferation, intracellular calcium flux and Erk MAPK activation (Suzuki et al., 1999; Marshall et al., 2000; Jacob et al., 2002; Jou et al., 2002). Given the opposite phenotype of Lyn-deficient mice to that of PI3K-mutant mice, it was always a possibility that the negative regulatory role of Lyn in BCR signalling could include PI3K. Using pharmaceutical inhibitors, we found that the hyper-sensitive phenotype of Lyn-deficient primary B cells in response to BCR ligation, such as Erk MAP kinase activation, calcium elevation and hyper-proliferation, were attenuated by removal of PI3K activity. Furthermore, the specific kinase activity of PI3K from primary B cells was found to be higher both before and after BCR-stimulation, confirming the inhibition of Lyn on PI3K activity. In a search for the factors that cause the activation of PI3K in primary B cells, we found that the remaining Src family PTKs (SFKs) were required for the elevated PI3K activation in absence of Lyn. Consistent with this, the BCR-induced tyrosine phosphorylation of a PI3K-associated protein was inhibitable by pp2 (an SFK inhibitor), defining it as being down stream of SFK. Furthermore, SFK dependent phosphorylation of this PI3K associated protein was enhanced following BCR ligation in Lyn-deficient B cells, suggesting a counter-balancing role for Lyn with the other SFKs in PI3K activation (Chapter 5).

The activity of SFKs is regulated by the phosphorylation status of their C-terminal Tyr527, which is phosphorylated by c-Src tyrosine kinase (CSK) for kinase repression (Cooper et al., 1993; Hata et al., 1994), and dephosphorylated by the receptor tyrosine phosphatase CD45 for kinase activation (Yanagi et al., 1996). A newly identified adaptor that has affinity for lipid rafts, known as phosphorprotein associated with GEMs (PAG) [also called Csk-binding protine (cbp)] is believed to recruit the cytoplasmic Csk to the lipid rafts where SFKs reside (Simons and Ikonen 1997; Cheng et al., 1999), facilitating the suppression of SFKs (Kawabuchi et al., 2000; Brdicka et al., 2000). Since Lyn is the predominant SFKs expressed in the lipid rafts of B cells, it could very likely be that Lyn has a feed-back inhibition on the activity of

all SFKs including itself by phosphorylation of the Csk recruiting molecule, PAG/cbp. This hypothesis is currently under investigation.

6.3: CONCLUSION

Lyn protein tyrosine kinase is the predominantly expressed Src family member in B lymphocytes and has both positive and negative regulatory roles in BCR-induced signal transduction. Accumulating evidence, however, indicates that the positive functions of Lyn following BCR ligation are redundant, which is reflected not only in phosphorylation and initiation of traditional BCR pathways, but also in phosphorylation and initiation of the pathway from CD19, a B cell co-stimulatory molecule that helps reduce the threshold for BCR stimulation. The irreplaceable functions of Lyn in primary B cell are to set negative feed-back control of the signalling cascades following BCR ligation by phosphorylating ITIM containing surface molecules that recruit and activate phosphatases. Besides, the data present in this thesis indicate that it is also possible that Lyn uniquely phosphorylates an adaptor molecule in lipid rafts to recruit Csk for suppression of other Src family PTK activity, which is necessary for PI3K activity in primary B cells. In this thesis we show for the first time dysregulated PI3K activity in Lyn-deficient B cells and present evidence to show that the biochemical consequences of Lyn deficiency in B cell all appear to depend on the dysregulation of PI3K.

Despite the progress described here, fully elucidating the mechanisms of Lyn activity in B cells requires additional work. An important challenge in the future is to verify the *in vitro* findings reported here in *in vivo* models. These studies may well contribute not only to the knowledge of B cell biology but also to the development of pharmaceutical reagents for better management of human autoimmune diseases, which may have dysregulated Lyn as a contributing or causative factor (Liossis et al., 2001).

REFERENCE

- Achatz, G., Nitschke, L., Lamers, M. C. (1997). Effect of transmembrane and cytoplasmic domains of IgE on the IgE response. *Science* 276:409-11.
- Adachi, T., Flaswinkel, H., Yakura, H., Reth, M., Tsubata, T. (1998). The B cell surface protein CD72 recruits the tyrosine phosphatase SHP-1 upon tyrosine phosphorylation. *J Immunol* 160:4662-5.
- Adachi, T., Wakabayashi, C., Nakayama, T., Yakura, H., Tsubata, T. (2000). CD72 negatively regulates signaling through the antigen receptor of B cells. *J Immunol* 164:1223-9.
- Adachi, T., Wienands, J., Wakabayashi, C., Yakura, H., Reth, M., Tsubata, T. (2001). SHP-1 requires inhibitory co-receptors to down-modulate B cell antigen receptor-mediated phosphorylation of cellular substrates. *J Biol Chem* 276:26648-55.
- Akhtar, S. S., Wani, B. A., Bano, Z. A., Salim, K. P., Handoo, F. A. (1996). 5-Fluorouracil-induced severe but reversible cardiogenic shock: a case report. *Tumori* 82:505-7.
- Alessi, D. R., Andjelkovic, M., Caudwell, B., Cron, P., Morrice, N., Cohen, P., Hemmings, B. A. (1996). Mechanism of activation of protein kinase B by insulin and IGF-1. *Embo J* 15:6541-51.
- Andjelkovic, M., Alessi, D. R., Meier, R., Fernandez, A., Lamb, N. J., Frech, M., Cron, P., Cohen, P., Lucocq, J. M., Hemmings, B. A. (1997). Role of translocation in the activation and function of protein kinase B. *J Biol Chem* 272:31515-24.
- Aoki, Y., Isselbacher, K. J., Pillai, S. (1994). Bruton tyrosine kinase is tyrosine phosphorylated and activated in pre-B lymphocytes and receptor-ligated B cells. *Proc Natl Acad Sci U S A* 91:10606-9.
- Arcaro, A., Volinia, S., Zvelebil, M. J., Stein, R., Watton, S. J., Layton, M. J., Gout, I., Ahmadi, K., Downward, J., Waterfield, M. D. (1998). Human phosphoinositide 3-kinase C2beta, the role of calcium and the C2 domain in enzyme activity. *J Biol Chem* 273:33082-90.
- Arcaro, A., Wymann, M. P. (1993). Wortmannin is a potent phosphatidylinositol 3-kinase inhibitor: the role of phosphatidylinositol 3,4,5-trisphosphate in neutrophil responses. *Biochem J* 296:297-301.
- Astoul, E., Watton, S., Cantrell, D. (1999). The dynamics of protein kinase B regulation during B cell antigen receptor engagement. *J Cell Biol* 145:1511-20.
- Bae, Y. S., Cantley, L. G., Chen, C. S., Kim, S. R., Kwon, K. S., Rhee, S. G. (1998). Activation of phospholipase C-gamma by phosphatidylinositol 3,4,5-trisphosphate. *J Biol Chem* 273:4465-9.
- Baeuerle, P. A., Henkel, T. (1994). Function and activation of NF-kappa B in the immune system. *Annu Rev Immunol* 12:141-79.
- Barbazuk, S. M., Gold, M. R. (1999). Protein kinase C-delta is a target of B-cell antigen receptor signaling. *Immunol Lett* 69:259-67.
- Barber, E. K., Dasgupta, J. D., Schlossman, S. F., Trevillyan, J. M., Rudd, C. E. (1989). The CD4 and CD8 antigens are coupled to a protein-tyrosine kinase (p56lck) that phosphorylates the CD3 complex. *Proc Natl Acad Sci U S A* 86:3277-81.
- Baxter, A. G., Hodgkin, P. D. (2002). Activation rules: the two-signal theories of immune activation. *Nat Rev Immunol* 2:439-46.
- Beitz, L. O., Fruman, D. A., Kurosaki, T., Cantley, L. C., Scharenberg, A. M. (1999). SYK is upstream of phosphoinositide 3-kinase in B cell receptor signaling. *J Biol Chem* 274:32662-6.

- Bellacosa, A., Chan, T. O., Ahmed, N. N., Datta, K., Malstrom, S., Stokoe, D., McCormick, F., Feng, J., Tsichlis, P. (1998). Akt activation by growth factors is a multiple-step process: the role of the PH domain. *Oncogene* 17:313-25.
- Benhamou, L. E., Cazenave, P. A., Sarthou, P. (1990). Anti-immunoglobulins induce death by apoptosis in WEHI-231 B lymphoma cells. *Eur J Immunol* 20:1405-7.
- Bergman, M., Mustelin, T., Oetken, C., Partanen, J., Flint, N. A., Amrein, K. E., Autero, M., Burn, P., Alitalo, K. (1992). The human p50csk tyrosine kinase phosphorylates p56lck at Tyr-505 and down regulates its catalytic activity. *Embo J* 11:2919-24.
- Berridge, M. J., Heslop, J. P., Irvine, R. F., Brown, K. D. (1984). Inositol trisphosphate formation and calcium mobilization in Swiss 3T3 cells in response to platelet-derived growth factor. *Biochem J* 222:195-201.
- Bijsterbosch, M. K., Meade, C. J., Turner, G. A., Klaus, G. G. (1985). B lymphocyte receptors and polyphosphoinositide degradation. *Cell* 41:999-1006.
- Birge, R. B., Hanafusa, H. (1993). Closing in on SH2 specificity. *Science* 262:1522-4.
- Blery, M., Kubagawa, H., Chen, C. C., Vely, F., Cooper, M. D., Vivier, E. (1998). The paired Ig-like receptor PIR-B is an inhibitory receptor that recruits the protein-tyrosine phosphatase SHP-1. *Proc Natl Acad Sci U S A* 95:2446-51.
- Bondeva, T., Pirola, L., Bulgarelli-Leva, G., Rubio, I., Wetzker, R., Wymann, M. P. (1998). Bifurcation of lipid and protein kinase signals of PI3Kgamma to the protein kinases PKB and MAPK. *Science* 282:293-6.
- Bonfini, L., Karlovich, C. A., Dasgupta, C., Banerjee, U. (1992). The Son of sevenless gene product: a putative activator of Ras. *Science* 255:603-6.
- Borlado, L. R., Redondo, C., Alvarez, B., Jimenez, C., Criado, L. M., Flores, J., Marcos, M. A., Martinez, A. C., Balomenos, D., Carrera, A. C. (2000). Increased phosphoinositide 3-kinase activity induces a lymphoproliferative disorder and contributes to tumor generation in vivo. *Faseb J* 14:895-903.
- Bradbury, L. E., Kansas, G. S., Levy, S., Evans, R. L., Tedder, T. F. (1992). The CD19/CD21 signal transducing complex of human B lymphocytes includes the target of antiproliferative antibody-1 and Leu-13 molecules. *J Immunol* 149:2841-50.
- Bras, A., Martinez, A. C., Baixeras, E. (1997). B cell receptor cross-linking prevents Fas-induced cell death by inactivating the IL-1 beta-converting enzyme protease and regulating Bcl-2/Bcl-x expression. *J Immunol* 159:3168-77.
- Brdicka, T., Pavlistova, D., Leo, A., Bruyns, E., Korinek, V., Angelisova, P., Scherer, J., Shevchenko, A., Hilgert, I., Cerny, J., Drbal, K., Kuramitsu, Y., Kornacker, B., Horejsi, V., Schraven, B. (2000). Phosphoprotein associated with glycosphingolipid-enriched microdomains (PAG), a novel ubiquitously expressed transmembrane adaptor protein, binds the protein tyrosine kinase csk and is involved in regulation of T cell activation. *J Exp Med* 191:1591-604.
- Brickell, P. M. (1992). The p60c-src family of protein-tyrosine kinases: structure, regulation, and function. *Crit Rev Oncog* 3:401-46.
- Brooks, S. R., Li, X., Volanakis, E. J., Carter, R. H. (2000). Systematic analysis of the role of CD19 cytoplasmic tyrosines in enhancement of activation in Daudi human B cells: clustering of phospholipase C and Vav and of Grb2 and Sos with different CD19 tyrosines. *J Immunol* 164:3123-31.
- Brown, D. A., Rose, J. K. (1992). Sorting of GPI-anchored proteins to glycolipid-enriched membrane subdomains during transport to the apical cell surface. *Cell* 68:533-44.

- Brugge, J. S., Cotton, P. C., Queral, A. E., Barrett, J. N., Nonner, D., Keane, R. W. (1985). Neurons express high levels of a structurally modified, activated form of pp60c-src. *Nature* 316:554-7.
- Brunati, A. M., Donella-Deana, A., Ruzzene, M., Marin, O., Pinna, L. A. (1995). Site specificity of p72syk protein tyrosine kinase: efficient phosphorylation of motifs recognized by Src homology 2 domains of the Src family. *FEBS Lett* 367:149-52.
- Brunet, A., Bonni, A., Zigmond, M. J., Lin, M. Z., Juo, P., Hu, L. S., Anderson, M. J., Arden, K. C., Blenis, J., Greenberg, M. E. (1999). Akt promotes cell survival by phosphorylating and inhibiting a Forkhead transcription factor. *Cell* 96:857-68.
- Buhl, A. M., Cambier, J. C. (1997). Co-receptor and accessory regulation of B-cell antigen receptor signal transduction. *Immunol Rev* 160:127-38.
- Buhl, A. M., Cambier, J. C. (1999). Phosphorylation of CD19 Y484 and Y515, and linked activation of phosphatidylinositol 3-kinase, are required for B cell antigen receptor-mediated activation of Bruton's tyrosine kinase. *J Immunol* 162:4438-46.
- Buhl, A. M., Pleiman, C. M., Rickert, R. C., Cambier, J. C. (1997). Qualitative regulation of B cell antigen receptor signaling by CD19: selective requirement for PI3-kinase activation, inositol-1,4,5-trisphosphate production and Ca²⁺ mobilization. *J Exp Med* 186:1897-910.
- Burg, D. L., Furlong, M. T., Harrison, M. L., Geahlen, R. L. (1994). Interactions of Lyn with the antigen receptor during B cell activation. *J Biol Chem* 269:28136-42.
- Burkhardt, A. L., Brunswick, M., Bolen, J. B., Mond, J. J. (1991). Anti-immunoglobulin stimulation of B lymphocytes activates src-related protein-tyrosine kinases. *Proc Natl Acad Sci U S A* 88:7410-4.
- Cahir McFarland, E. D., Hurley, T. R., Pingel, J. T., Sefton, B. M., Shaw, A., Thomas, M. L. (1993). Correlation between Src family member regulation by the protein-tyrosine-phosphatase CD45 and transmembrane signaling through the T-cell receptor. *Proc Natl Acad Sci U S A* 90:1402-6.
- Cambier, J. C. (1995). Antigen and Fc receptor signaling. The awesome power of the immunoreceptor tyrosine-based activation motif (ITAM). *J Immunol* 155:3281-5.
- Campbell, K. S., Hager, E. J., Friedrich, R. J., Cambier, J. C. (1991). IgM antigen receptor complex contains phosphoprotein products of B29 and mb-1 genes. *Proc Natl Acad Sci U S A* 88:3982-6.
- Campbell, M. A., Klinman, N. R. (1995). Phosphotyrosine-dependent association between CD22 and protein tyrosine phosphatase 1C. *Eur J Immunol* 25:1573-9.
- Cardone, M. H., Roy, N., Stennicke, H. R., Salvesen, G. S., Franke, T. F., Stanbridge, E., Frisch, S., Reed, J. C. (1998). Regulation of cell death protease caspase-9 by phosphorylation. *Science* 282:1318-21.
- Carpenter, C. L., Auger, K. R., Duckworth, B. C., Hou, W. M., Schaffhausen, B., Cantley, L. C. (1993). A tightly associated serine/threonine protein kinase regulates phosphoinositide 3-kinase activity. *Mol Cell Biol* 13:1657-65.
- Carpino, N., Wisniewski, D., Strife, A., Marshak, D., Kobayashi, R., Stillman, B., Clarkson, B. (1997). p62(dok): a constitutively tyrosine-phosphorylated, GAP-associated protein in chronic myelogenous leukemia progenitor cells. *Cell* 88:197-204.
- Carroll, M. C. (1998). CD21/CD35 in B cell activation. *Semin Immunol* 10:279-86.
- Carsetti, R. (2000). The development of B cells in the bone marrow is controlled by the balance between cell-autonomous mechanisms and signals from the microenvironment. *J Exp Med* 191:5-8.
- Carter, R. H., Fearon, D. T. (1992). CD19: lowering the threshold for antigen receptor stimulation of B lymphocytes. *Science* 256:105-7.

- Carter, R. H., Park, D. J., Rhee, S. G., Fearon, D. T. (1991). Tyrosine phosphorylation of phospholipase C induced by membrane immunoglobulin in B lymphocytes. *Proc Natl Acad Sci U S A* 88:2745-9.
- Carter, R. H., Spycher, M. O., Ng, Y. C., Hoffman, R., Fearon, D. T. (1988). Synergistic interaction between complement receptor type 2 and membrane IgM on B lymphocytes. *J Immunol* 141:457-63.
- Carter, R. H., Tuveson, D. A., Park, D. J., Rhee, S. G., Fearon, D. T. (1991). The CD19 complex of B lymphocytes. Activation of phospholipase C by a protein tyrosine kinase-dependent pathway that can be enhanced by the membrane IgM complex. *J Immunol* 147:3663-71.
- Carter, R. H., Wang, Y., Brooks, S. (2002). Role of CD19 signal transduction in B cell biology. *Immunol Res* 26:45-54.
- Casey, P. J. (1995). Protein lipidation in cell signaling. *Science* 268:221-5.
- Casillas, A., Hanekom, C., Williams, K., Katz, R., Nel, A. E. (1991). Stimulation of B-cells via the membrane immunoglobulin receptor or with phorbol myristate 13-acetate induces tyrosine phosphorylation and activation of a 42-kDa microtubule-associated protein-2 kinase. *J Biol Chem* 266:19088-94.
- Cassel, D. L., Keller, M. A., Surrey, S., Schwartz, E., Schreiber, A. D., Rappaport, E. F., McKenzie, S. E. (1993). Differential expression of Fc gamma RIIA, Fc gamma RIIB and Fc gamma RIIC in hematopoietic cells: analysis of transcripts. *Mol Immunol* 30:451-60.
- Chalupny, N. J., Aruffo, A., Esselstyn, J. M., Chan, P. Y., Bajorath, J., Blake, J., Gilliland, L. K., Ledbetter, J. A., Tepper, M. A. (1995). Specific binding of Fyn and phosphatidylinositol 3-kinase to the B cell surface glycoprotein CD19 through their src homology 2 domains. *Eur J Immunol* 25:2978-84.
- Chalupny, N. J., Kanner, S. B., Schieven, G. L., Wee, S. F., Gilliland, L. K., Aruffo, A., Ledbetter, J. A. (1993). Tyrosine phosphorylation of CD19 in pre-B and mature B cells. *Embo J* 12:2691-6.
- Chan, A. C., Irving, B. A., Fraser, J. D., Weiss, A. (1991). The zeta chain is associated with a tyrosine kinase and upon T-cell antigen receptor stimulation associates with ZAP-70, a 70-kDa tyrosine phosphoprotein. *Proc Natl Acad Sci U S A* 88:9166-70.
- Chan, A. C., Iwashima, M., Turck, C. W., Weiss, A. (1992). ZAP-70: a 70 kd protein-tyrosine kinase that associates with the TCR zeta chain. *Cell* 71:649-62.
- Chan, A. C., van Oers, N. S., Tran, A., Turka, L., Law, C. L., Ryan, J. C., Clark, E. A., Weiss, A. (1994). Differential expression of ZAP-70 and Syk protein tyrosine kinases, and the role of this family of protein tyrosine kinases in TCR signaling. *J Immunol* 152:4758-66.
- Chan, V. W., Lowell, C. A., DeFranco, A. L. (1998). Defective negative regulation of antigen receptor signaling in Lyn- deficient B lymphocytes. *Curr Biol* 8:545-53.
- Chan, V. W., Meng, F., Soriano, P., DeFranco, A. L., Lowell, C. A. (1997). Characterization of the B lymphocyte populations in Lyn-deficient mice and the role of Lyn in signal initiation and down-regulation. *Immunity* 7:69-81.
- Chen, J., Lansford, R., Stewart, V., Young, F., Alt, F. W. (1993). RAG-2-deficient blastocyst complementation: an assay of gene function in lymphocyte development. *Proc Natl Acad Sci U S A* 90:4528-32.
- Cheng, A. M., Rowley, B., Pao, W., Hayday, A., Bolen, J. B., Pawson, T. (1995). Syk tyrosine kinase required for mouse viability and B-cell development. *Nature* 378:303-6.
- Cheng, G., Ye, Z. S., Baltimore, D. (1994). Binding of Bruton's tyrosine kinase to Fyn, Lyn, or Hck through a Src homology 3 domain-mediated interaction. *Proc Natl Acad Sci U S A* 91:8152-5.

- Cheng, P. C., Cherukuri, A., Dykstra, M., Malapati, S., Sproul, T., Chen, M. R., Pierce, S. K. (2001). Floating the raft hypothesis: the roles of lipid rafts in B cell antigen receptor function. *Semin Immunol* 13:107-14.
- Cheng, P. C., Dykstra, M. L., Mitchell, R. N., Pierce, S. K. (1999). A role for lipid rafts in B cell antigen receptor signaling and antigen targeting. *J Exp Med* 190:1549-60.
- Cherukuri, A., Cheng, P. C., Sohn, H. W., Pierce, S. K. (2001). The CD19/CD21 complex functions to prolong B cell antigen receptor signaling from lipid rafts. *Immunity* 14:169-79.
- Chu, D. H., Morita, C. T., Weiss, A. (1998). The Syk family of protein tyrosine kinases in T-cell activation and development. *Immunol Rev* 165:167-80.
- Clipstone, N. A., Crabtree, G. R. (1992). Identification of calcineurin as a key signalling enzyme in T-lymphocyte activation. *Nature* 357:695-7.
- Cobb, M. H. (1999). MAP kinase pathways. *Prog Biophys Mol Biol* 71:479-500.
- Coffman, R. L., Weissman, I. L. (1981). A monoclonal antibody that recognizes B cells and B cell precursors in mice. *J Exp Med* 153:269-79.
- Cooper, J. A., Howell, B. (1993). The when and how of Src regulation. *Cell* 73:1051-4.
- Corcoran, L. M., Tawfilis, S., Barlow, L. J. (1999). Generation of B lymphoma cell lines from knockout mice by transformation in vivo with an Emu-myc transgene. *J Immunol Methods* 228:131-8.
- Cornall, R. J., Cyster, J. G., Hibbs, M. L., Dunn, A. R., Otipoby, K. L., Clark, E. A., Goodnow, C. C. (1998). Polygenic autoimmune traits: Lyn, CD22, and SHP-1 are limiting elements of a biochemical pathway regulating BCR signaling and selection. *Immunity* 8:497-508.
- Couture, C., Deckert, M., Williams, S., Russo, F. O., Altman, A., Mustelin, T. (1996). Identification of the site in the Syk protein tyrosine kinase that binds the SH2 domain of Lck. *J Biol Chem* 271:24294-9.
- Couture, C., Williams, S., Gauthier, N., Taylor, P., Mustelin, T. (1997). Role of Tyr518 and Tyr519 in the regulation of catalytic activity and substrate phosphorylation by Syk protein-tyrosine kinase. *Eur J Biochem* 246:447-51.
- Crabtree, G. R., Clipstone, N. A. (1994). Signal transmission between the plasma membrane and nucleus of T lymphocytes. *Annu Rev Biochem* 63:1045-83.
- Craxton, A., Jiang, A., Kurosaki, T., Clark, E. A. (1999). Syk and Bruton's tyrosine kinase are required for B cell antigen receptor-mediated activation of the kinase Akt. *J Biol Chem* 274:30644-50.
- Crespo, P., Schuebel, K. E., Ostrom, A. A., Gutkind, J. S., Bustelo, X. R. (1997). Phosphotyrosine-dependent activation of Rac-1 GDP/GTP exchange by the vav proto-oncogene product. *Nature* 385:169-72.
- Crews, C. M., Alessandrini, A., Erikson, R. L. (1992). The primary structure of MEK, a protein kinase that phosphorylates the ERK gene product. *Science* 258:478-80.
- Cyster, J. G., Goodnow, C. C. (1997). Tuning antigen receptor signaling by CD22: integrating cues from antigens and the microenvironment. *Immunity* 6:509-17.
- Cyster, J. G., Healy, J. I., Kishihara, K., Mak, T. W., Thomas, M. L., Goodnow, C. C. (1996). Regulation of B-lymphocyte negative and positive selection by tyrosine phosphatase CD45. *Nature* 381:325-8.
- D'Ambrosio, D., Hippen, K. L., Minskoff, S. A., Mellman, I., Pani, G., Siminovitch, K. A., Cambier, J. C. (1995). Recruitment and activation of PTP1C in negative regulation of antigen receptor signaling by

- Fc gamma RIIB1. *Science* 268:293-7.
- Datta, K., Franke, T. F., Chan, T. O., Makris, A., Yang, S. I., Kaplan, D. R., Morrison, D. K., Golemis, E. A., Tsichlis, P. N. (1995). AH/PH domain-mediated interaction between Akt molecules and its potential role in Akt regulation. *Mol Cell Biol* 15:2304-10.
- Datta, S. R., Dudek, H., Tao, X., Masters, S., Fu, H., Gotoh, Y., Greenberg, M. E. (1997). Akt phosphorylation of BAD couples survival signals to the cell-intrinsic death machinery. *Cell* 91:231-41.
- Davidson, D., Bakinowski, M., Thomas, M. L., Horejsi, V., Veillette, A. (2003). Phosphorylation-dependent regulation of T-cell activation by PAG/Cbp, a lipid raft-associated transmembrane adaptor. *Mol Cell Biol* 23:2017-28.
- de Fougerolles, A. R., Batista, F., Johnsson, E., Fearon, D. T. (2001). IgM and stromal cell-associated heparan sulfate/heparin as complement-independent ligands for CD19. *Eur J Immunol* 31:2189-99.
- De Vendittis, E., Zahn, R., Fasano, O. (1986). Regeneration of the GTP-bound from the GDP-bound form of human and yeast ras proteins by nucleotide exchange. Stimulatory effect of organic and inorganic polyphosphates. *Eur J Biochem* 161:473-8.
- DeBell, K. E., Stoica, B. A., Veri, M. C., Di Baldassarre, A., Miscia, S., Graham, L. J., Rellahan, B. L., Ishiai, M., Kurosaki, T., Bonvini, E. (1999). Functional independence and interdependence of the Src homology domains of phospholipase C-gamma1 in B-cell receptor signal transduction. *Mol Cell Biol* 19:7388-98.
- Deblandre, G. A., Marinx, O. P., Evans, S. S., Majjaj, S., Leo, O., Caput, D., Huez, G. A., Wathelet, M. G. (1995). Expression cloning of an interferon-inducible 17-kDa membrane protein implicated in the control of cell growth. *J Biol Chem* 270:23860-6.
- Deckert, M., Tartare-Deckert, S., Couture, C., Mustelin, T., Altman, A. (1996). Functional and physical interactions of Syk family kinases with the Vav proto-oncogene product. *Immunity* 5:591-604.
- DeFranco, A. L. (1993). Structure and function of the B cell antigen receptor. *Annu Rev Cell Biol* 9:377-410.
- DeFranco, A. L., Law, D. A. (1995). Tyrosine phosphatases and the antibody response. *Science* 268:263-4.
- del Peso, L., Gonzalez-Garcia, M., Page, C., Herrera, R., Nunez, G. (1997). Interleukin-3-induced phosphorylation of BAD through the protein kinase Akt. *Science* 278:687-9.
- Dempsey, P. W., Allison, M. E., Akkaraju, S., Goodnow, C. C., Fearon, D. T. (1996). C3d of complement as a molecular adjuvant: bridging innate and acquired immunity. *Science* 271:348-50.
- Dent, P., Haser, W., Haystead, T. A., Vincent, L. A., Roberts, T. M., Sturgill, T. W. (1992). Activation of mitogen-activated protein kinase kinase by v-Raf in NIH 3T3 cells and in vitro. *Science* 257:1404-7.
- Dolmetsch, R. E., Lewis, R. S., Goodnow, C. C., Healy, J. I. (1997). Differential activation of transcription factors induced by Ca²⁺ response amplitude and duration. *Nature* 386:855-8.
- Domin, J., Pages, F., Volinia, S., Rittenhouse, S. E., Zvelebil, M. J., Stein, R. C., Waterfield, M. D. (1997). Cloning of a human phosphoinositide 3-kinase with a C2 domain that displays reduced sensitivity to the inhibitor wortmannin. *Biochem J* 326:139-47.
- Domin, J., Waterfield, M. D. (1997). Using structure to define the function of phosphoinositide 3-kinase family members. *FEBS Lett* 410:91-5.
- Donjerkovic, D., Scott, D. W. (2000). Activation-induced cell death in B lymphocytes. *Cell Res* 10:179-92.

- Doody, G. M., Dempsey, P. W., Fearon, D. T. (1996). Activation of B lymphocytes: integrating signals from CD19, CD22 and Fc gamma RIIB1. *Curr Opin Immunol* 8:378-82.
- Doody, G. M., Justement, L. B., Delibrias, C. C., Matthews, R. J., Lin, J., Thomas, M. L., Fearon, D. T. (1995). A role in B cell activation for CD22 and the protein tyrosine phosphatase SHP. *Science* 269:242-4.
- Downward, J. (1998). Mechanisms and consequences of activation of protein kinase B/Akt. *Curr Opin Cell Biol* 10:262-7.
- Duckworth, B. C., Cantley, L. C. (1997). Conditional inhibition of the mitogen-activated protein kinase cascade by wortmannin. Dependence on signal strength. *J Biol Chem* 272:27665-70.
- Dustin, L. B., Plas, D. R., Wong, J., Hu, Y. T., Soto, C., Chan, A. C., Thomas, M. L. (1999). Expression of dominant-negative src-homology domain 2-containing protein tyrosine phosphatase-1 results in increased Syk tyrosine kinase activity and B cell activation. *J Immunol* 162:2717-24.
- Dymecki, S. M., Niederhuber, J. E., Desiderio, S. V. (1990). Specific expression of a tyrosine kinase gene, blk, in B lymphoid cells. *Science* 247:332-6.
- Egloff, A. M., Desiderio, S. (2001). Identification of phosphorylation sites for Bruton's tyrosine kinase within the transcriptional regulator BAP/TFII-I. *J Biol Chem* 276:27806-15.
- Eiseman, E., Bolen, J. B. (1992). Engagement of the high-affinity IgE receptor activates src protein-related tyrosine kinases. *Nature* 355:78-80.
- Engel, P., Zhou, L. J., Ord, D. C., Sato, S., Koller, B., Tedder, T. F. (1995). Abnormal B lymphocyte development, activation, and differentiation in mice that lack or overexpress the CD19 signal transduction molecule. *Immunity* 3:39-50.
- Erpel, T., Courtneidge, S. A. (1995). Src family protein tyrosine kinases and cellular signal transduction pathways. *Curr Opin Cell Biol* 7:176-82.
- Falasca, M., Logan, S. K., Lehto, V. P., Baccante, G., Lemmon, M. A., Schlessinger, J. (1998). Activation of phospholipase C gamma by PI 3-kinase-induced PH domain-mediated membrane targeting. *Embo J* 17:414-22.
- Fanger, N. A., Voigtlaender, D., Liu, C., Swink, S., Wardwell, K., Fisher, J., Graziano, R. F., Pfefferkorn, L. C., Guyre, P. M. (1997). Characterization of expression, cytokine regulation, and effector function of the high affinity IgG receptor Fc gamma RI (CD64) expressed on human blood dendritic cells. *J Immunol* 158:3090-8.
- Fearon, D. T., Carroll, M. C. (2000). Regulation of B lymphocyte responses to foreign and self-antigens by the CD19/CD21 complex. *Annu Rev Immunol* 18:393-422.
- Felder, S., Zhou, M., Hu, P., Urena, J., Ullrich, A., Chaudhuri, M., White, M., Shoelson, S. E., Schlessinger, J. (1993). SH2 domains exhibit high-affinity binding to tyrosine-phosphorylated peptides yet also exhibit rapid dissociation and exchange. *Mol Cell Biol* 13:1449-55.
- Feng, S., Chen, J. K., Yu, H., Simon, J. A., Schreiber, S. L. (1994). Two binding orientations for peptides to the Src SH3 domain: development of a general model for SH3-ligand interactions. *Science* 266:1241-7.
- Fluckiger, A. C., Li, Z., Kato, R. M., Wahl, M. I., Ochs, H. D., Longnecker, R., Kinet, J. P., Witte, O. N., Scharenberg, A. M., Rawlings, D. J. (1998). Btk/Tec kinases regulate sustained increases in intracellular Ca²⁺ following B-cell receptor activation. *Embo J* 17:1973-85.
- Franke, T. F., Yang, S. I., Chan, T. O., Datta, K., Kazlauskas, A., Morrison, D. K., Kaplan, D. R., Tsichlis, P. N. (1995). The protein kinase encoded by the Akt proto-oncogene is a target of the PDGF-activated phosphatidylinositol 3-kinase. *Cell* 81:727-36.

- Fruman, D. A., Ferl, G. Z., An, S. S., Donahue, A. C., Satterthwaite, A. B., Witte, O. N. (2002). Phosphoinositide 3-kinase and Bruton's tyrosine kinase regulate overlapping sets of genes in B lymphocytes. *Proc Natl Acad Sci U S A* 99:359-64.
- Fruman, D. A., Mauvais-Jarvis, F., Pollard, D. A., Yballe, C. M., Brazil, D., Bronson, R. T., Kahn, C. R., Cantley, L. C. (2000). Hypoglycaemia, liver necrosis and perinatal death in mice lacking all isoforms of phosphoinositide 3-kinase p85 alpha. *Nat Genet* 26:379-82.
- Fruman, D. A., Meyers, R. E., Cantley, L. C. (1998). Phosphoinositide kinases. *Annu Rev Biochem* 67:481-507.
- Fruman, D. A., Snapper, S. B., Yballe, C. M., Davidson, L., Yu, J. Y., Alt, F. W., Cantley, L. C. (1999). Impaired B cell development and proliferation in absence of phosphoinositide 3-kinase p85alpha. *Science* 283:393-7.
- Fry, M. J. (1994). Structure, regulation and function of phosphoinositide 3-kinases. *Biochim Biophys Acta* 1226:237-68.
- Fu, C., Chan, A. C. (1997). Identification of two tyrosine phosphoproteins, pp70 and pp68, which interact with phospholipase Cgamma, Grb2, and Vav after B cell antigen receptor activation. *J Biol Chem* 272:27362-8.
- Fu, C., Turck, C. W., Kurosaki, T., Chan, A. C. (1998). BLNK: a central linker protein in B cell activation. *Immunity* 9:93-103.
- Fujimoto, M., Bradney, A. P., Poe, J. C., Steeber, D. A., Tedder, T. F. (1999a). Modulation of B lymphocyte antigen receptor signal transduction by a CD19/CD22 regulatory loop. *Immunity* 11:191-200.
- Fujimoto, M., Fujimoto, Y., Poe, J. C., Jansen, P. J., Lowell, C. A., DeFranco, A. L., Tedder, T. F. (2000b). CD19 regulates Src family protein tyrosine kinase activation in B lymphocytes through processive amplification. *Immunity* 13:47-57.
- Fujimoto, M., Poe, J. C., Hasegawa, M., Tedder, T. F. (2000a). CD19 regulates intrinsic B lymphocyte signal transduction and activation through a novel mechanism of processive amplification. *Immunol Res* 22:281-98.
- Fujimoto, M., Poe, J. C., Hasegawa, M., Tedder, T. F. (2001). CD19 amplification of B lymphocyte Ca²⁺ responses: a role for Lyn sequestration in extinguishing negative regulation. *J Biol Chem* 276:44820-7.
- Fujimoto, M., Poe, J. C., Jansen, P. J., Sato, S., Tedder, T. F. (1999b). CD19 amplifies B lymphocyte signal transduction by regulating Src- family protein tyrosine kinase activation. *J Immunol* 162:7088-94.
- Fujimoto, M., Poe, J. C., Satterthwaite, A. B., Wahl, M. I., Witte, O. N., Tedder, T. F. (2002). Complementary roles for CD19 and Bruton's tyrosine kinase in B lymphocyte signal transduction. *J Immunol* 168:5465-76.
- Fukamachi, H., Yamada, N., Miura, T., Kato, T., Ishikawa, M., Gulbins, E., Altman, A., Kawakami, Y., Kawakami, T. (1994). Identification of a protein, SPY75, with repetitive helix-turn-helix motifs and an SH3 domain as a major substrate for protein tyrosine kinase(s) activated by Fc epsilon RI cross-linking. *J Immunol* 152:642-52.
- Furlong, M. T., Mahrenholz, A. M., Kim, K. H., Ashendel, C. L., Harrison, M. L., Geahlen, R. L. (1997). Identification of the major sites of autophosphorylation of the murine protein-tyrosine kinase Syk. *Biochim Biophys Acta* 1355:177-90.
- Goitsuka, R., Fujimura, Y., Mamada, H., Umeda, A., Morimura, T., Uetsuka, K., Doi, K., Tsuji, S.,

- Kitamura, D. (1998). BASH, a novel signaling molecule preferentially expressed in B cells of the bursa of Fabricius. *J Immunol* 161:5804-8.
- Gold, M. R., Chan, V. W., Turck, C. W., DeFranco, A. L. (1992). Membrane Ig cross-linking regulates phosphatidylinositol 3-kinase in B lymphocytes. *J Immunol* 148:2012-22.
- Gold, M. R., Crowley, M. T., Martin, G. A., McCormick, F., DeFranco, A. L. (1993). Targets of B lymphocyte antigen receptor signal transduction include the p21ras GTPase-activating protein (GAP) and two GAP-associated proteins. *J Immunol* 150:377-86.
- Gold, M. R., Ingham, R. J., McLeod, S. J., Christian, S. L., Scheid, M. P., Duronio, V., Santos, L., Matsuuchi, L. (2000). Targets of B-cell antigen receptor signaling: the phosphatidylinositol 3-kinase/Akt/glycogen synthase kinase-3 signaling pathway and the Rap1 GTPase. *Immunol Rev* 176:47-68.
- Gold, M. R., Law, D. A., DeFranco, A. L. (1990). Stimulation of protein tyrosine phosphorylation by the B-lymphocyte antigen receptor. *Nature* 345:810-3.
- Gold, M. R., Sanghera, J. S., Stewart, J., Pelech, S. L. (1992). Selective activation of p42 mitogen-activated protein (MAP) kinase in murine B lymphoma cell lines by membrane immunoglobulin cross-linking. Evidence for protein kinase C-independent and -dependent mechanisms of activation. *Biochem J* 287:269-76.
- Gold, M. R., Scheid, M. P., Santos, L., Dang-Lawson, M., Roth, R. A., Matsuuchi, L., Duronio, V., Krebs, D. L. (1999). The B cell antigen receptor activates the Akt (protein kinase B)/glycogen synthase kinase-3 signaling pathway via phosphatidylinositol 3-kinase. *J Immunol* 163:1894-905.
- Gong, S., Sanchez, M., Nussenzweig, M. C. (1996). Counterselection against D mu is mediated through immunoglobulin (Ig)alpha-Igbeta. *J Exp Med* 184:2079-84.
- Greenberg, S., Chang, P., Silverstein, S. C. (1994). Tyrosine phosphorylation of the gamma subunit of Fc gamma receptors, p72syk, and paxillin during Fc receptor-mediated phagocytosis in macrophages. *J Biol Chem* 269:3897-902.
- Grumont, R. J., Strasser, A., Gerondakis, S. (2002). B cell growth is controlled by phosphatidylinositol 3-kinase-dependent induction of Rel/NF-kappaB regulated c-myc transcription. *Mol Cell* 10:1283-94.
- Gu, H., Pratt, J. C., Burakoff, S. J., Neel, B. G. (1998). Cloning of p97/Gab2, the major SHP2-binding protein in hematopoietic cells, reveals a novel pathway for cytokine-induced gene activation. *Mol Cell* 2:729-40.
- Gu, H., Saito, K., Klamann, L. D., Shen, J., Fleming, T., Wang, Y., Pratt, J. C., Lin, G., Lim, B., Kinetic, J. P., Neel, B. G. (2001). Essential role for Gab2 in the allergic response. *Nature* 412:186-90.
- Gu, H., Tarlinton, D., Muller, W., Rajewsky, K., Forster, I. (1991). Most peripheral B cells in mice are ligand selected. *J Exp Med* 173:1357-71.
- Gulley, M. L., Ogata, L. C., Thorson, J. A., Dailey, M. O., Kemp, J. D. (1988). Identification of a murine pan-T cell antigen which is also expressed during the terminal phases of B cell differentiation. *J Immunol* 140:3751-7.
- Gupta, N., DeFranco, A. L. (2003). Visualizing lipid raft dynamics and early signaling events during antigen receptor-mediated B-lymphocyte activation. *Mol Biol Cell* 14:432-44.
- Haire, R. N., Ohta, Y., Lewis, J. E., Fu, S. M., Kroisel, P., Litman, G. W. (1994). TXK, a novel human tyrosine kinase expressed in T cells shares sequence identity with Tec family kinases and maps to 4p12. *Hum Mol Genet* 3:897-901.
- Hanke, J. H., Gardner, J. P., Dow, R. L., Changelian, P. S., Brissette, W. H., Weringer, E. J., Pollok, B. A., Connelly, P. A. (1996). Discovery of a novel, potent, and Src family-selective tyrosine kinase

- inhibitor. Study of Lck- and FynT-dependent T cell activation. *J Biol Chem* 271:695-701.
- Harder, K. W., Parsons, L. M., Armes, J., Evans, N., Kountouri, N., Clark, R., Quilici, C., Grail, D., Hodgson, G. S., Dunn, A. R., Hibbs, M. L. (2001). Gain- and loss-of-function Lyn mutant mice define a critical inhibitory role for Lyn in the myeloid lineage. *Immunity* 15:603-15.
- Harmer, S. L., DeFranco, A. L. (1997). Shc contains two Grb2 binding sites needed for efficient formation of complexes with SOS in B lymphocytes. *Mol Cell Biol* 17:4087-95.
- Hartley, S. B., Crosbie, J., Brink, R., Kantor, A. B., Basten, A., Goodnow, C. C. (1991). Elimination from peripheral lymphoid tissues of self-reactive B lymphocytes recognizing membrane-bound antigens. *Nature* 353:765-9.
- Hasbold, J., Klaus, G. G. (1990). Anti-immunoglobulin antibodies induce apoptosis in immature B cell lymphomas. *Eur J Immunol* 20:1685-90.
- Hasegawa, M., Fujimoto, M., Poe, J. C., Steeber, D. A., Lowell, C. A., Tedder, T. F. (2001a). A CD19-dependent signaling pathway regulates autoimmunity in Lyn- deficient mice. *J Immunol* 167:2469-78.
- Hasegawa, M., Fujimoto, M., Poe, J. C., Steeber, D. A., Tedder, T. F. (2001b). CD19 can regulate B lymphocyte signal transduction independent of complement activation. *J Immunol* 167:3190-200.
- Hashimoto, S., Iwamatsu, A., Ishiai, M., Okawa, K., Yamadori, T., Matsushita, M., Baba, Y., Kishimoto, T., Kurosaki, T., Tsukada, S. (1999). Identification of the SH2 domain binding protein of Bruton's tyrosine kinase as BLNK--functional significance of Btk-SH2 domain in B-cell antigen receptor-coupled calcium signaling. *Blood* 94:2357-64.
- Hata, A., Sabe, H., Kurosaki, T., Takata, M., Hanafusa, H. (1994). Functional analysis of Csk in signal transduction through the B-cell antigen receptor. *Mol Cell Biol* 14:7306-13.
- Hatada, M. H., Lu, X., Laird, E. R., Green, J., Morgenstern, J. P., Lou, M., Marr, C. S., Phillips, T. B., Ram, M. K., Theriault, K., et al. (1995). Molecular basis for interaction of the protein tyrosine kinase ZAP-70 with the T-cell receptor. *Nature* 377:32-8.
- Hattori, S., Yamashita, T., Copeland, T. D., Oroszlan, S., Shih, T. Y. (1986). Reactivity of a sulfhydryl group of the ras oncogene product p21 modulated by GTP binding. *J Biol Chem* 261:14582-6.
- Hayami, K., Fukuta, D., Nishikawa, Y., Yamashita, Y., Inui, M., Ohyama, Y., Hikida, M., Ohmori, H., Takai, T. (1997). Molecular cloning of a novel murine cell-surface glycoprotein homologous to killer cell inhibitory receptors. *J Biol Chem* 272:7320-7.
- Healy, J. I., Dolmetsch, R. E., Timmerman, L. A., Cyster, J. G., Thomas, M. L., Crabtree, G. R., Lewis, R. S., Goodnow, C. C. (1997). Different nuclear signals are activated by the B cell receptor during positive versus negative signaling. *Immunity* 6:419-28.
- Healy, J. I., Goodnow, C. C. (1998). Positive versus negative signaling by lymphocyte antigen receptors. *Annu Rev Immunol* 16:645-70.
- Hemmings, B. A. (1997). PH domains--a universal membrane adapter. *Science* 275:1899.
- Hempel, W. M., Schatzman, R. C., DeFranco, A. L. (1992). Tyrosine phosphorylation of phospholipase C-gamma 2 upon cross-linking of membrane Ig on murine B lymphocytes. *J Immunol* 148:3021-7.
- Herman, P. K., Stack, J. H., Emr, S. D. (1992). An essential role for a protein and lipid kinase complex in secretory protein sorting. *Trends in Cell Biology* 2:363-368.
- Hibbs, M. L., Dunn, A. R. (1997). Lyn, a src-like tyrosine kinase. *Int J Biochem Cell Biol* 29:397-400.
- Hibbs, M. L., Harder, K. W., Armes, J., Kountouri, N., Quilici, C., Casagrande, F., Dunn, A. R., Tarlinton, D. M. (2002). Sustained activation of Lyn tyrosine kinase in vivo leads to autoimmunity. *J*

Exp Med 196:1593-604.

Hibbs, M. L., Tarlinton, D. M., Armes, J., Grail, D., Hodgson, G., Maglitto, R., Stacker, S. A., Dunn, A. R. (1995). Multiple defects in the immune system of Lyn-deficient mice, culminating in autoimmune disease. *Cell* 83:301-11.

Hiles, I. D., Otsu, M., Volinia, S., Fry, M. J., Gout, I., Dhand, R., Panayotou, G., Ruiz-Larrea, F., Thompson, A., Totty, N. F., et al. (1992). Phosphatidylinositol 3-kinase: structure and expression of the 110 kd catalytic subunit. *Cell* 70:419-29.

Hippen, K. L., Buhl, A. M., D'Ambrosio, D., Nakamura, K., Persin, C., Cambier, J. C. (1997). Fc gammaRIIB1 inhibition of BCR-mediated phosphoinositide hydrolysis and Ca²⁺ mobilization is integrated by CD19 dephosphorylation. *Immunity* 7:49-58.

Ho, L. H., Uehara, T., Chen, C. C., Kubagawa, H., Cooper, M. D. (1999). Constitutive tyrosine phosphorylation of the inhibitory paired Ig-like receptor PIR-B. *Proc Natl Acad Sci U S A* 96:15086-90.

Holgado-Madruga, M., Moscatello, D. K., Emlet, D. R., Dieterich, R., Wong, A. J. (1997). Grb2-associated binder-1 mediates phosphatidylinositol 3-kinase activation and the promotion of cell survival by nerve growth factor. *Proc Natl Acad Sci U S A* 94:12419-24.

Hombach, J., Leclercq, L., Radbruch, A., Rajewsky, K., Reth, M. (1988). A novel 34-kd protein co-isolated with the IgM molecule in surface IgM-expressing cells. *Embo J* 7:3451-6.

Hombach, J., Lottspeich, F., Reth, M. (1990). Identification of the genes encoding the IgM-alpha and Ig-beta components of the IgM antigen receptor complex by amino-terminal sequencing. *Eur J Immunol* 20:2795-9.

Hombach, J., Tsubata, T., Leclercq, L., Stappert, H., Reth, M. (1990). Molecular components of the B-cell antigen receptor complex of the IgM class. *Nature* 343:760-2.

Hong, J. J., Yankee, T. M., Harrison, M. L., Geahlen, R. L. (2002). Regulation of signaling in B cells through the phosphorylation of Syk on linker region tyrosines. A mechanism for negative signaling by the Lyn tyrosine kinase. *J Biol Chem* 277:31703-14.

Hu, P., Mondino, A., Skolnik, E. Y., Schlessinger, J. (1993). Cloning of a novel, ubiquitously expressed human phosphatidylinositol 3-kinase and identification of its binding site on p85. *Mol Cell Biol* 13:7677-88.

Hurley, T. R., Hyman, R., Sefton, B. M. (1993). Differential effects of expression of the CD45 tyrosine protein phosphatase on the tyrosine phosphorylation of the lck, fyn, and c-src tyrosine protein kinases. *Mol Cell Biol* 13:1651-6.

Hutchcroft, J. E., Harrison, M. L., Geahlen, R. L. (1992). Association of the 72-kDa protein-tyrosine kinase PTK72 with the B cell antigen receptor. *J Biol Chem* 267:8613-9.

Inabe, K., Ishiai, M., Scharenberg, A. M., Freshney, N., Downward, J., Kurosaki, T. (2002). Vav3 modulates B cell receptor responses by regulating phosphoinositide 3-kinase activation. *J Exp Med* 195:189-200.

Inabe, K., Kurosaki, T. (2002). Tyrosine phosphorylation of B-cell adaptor for phosphoinositide 3-kinase is required for Akt activation in response to CD19 engagement. *Blood* 99:584-9.

Ingham, R. J., Holgado-Madruga, M., Siu, C., Wong, A. J., Gold, M. R. (1998). The Gab1 protein is a docking site for multiple proteins involved in signaling by the B cell antigen receptor. *J Biol Chem* 273:30630-7.

Ingham, R. J., Santos, L., Dang-Lawson, M., Holgado-Madruga, M., Dudek, P., Maroun, C. R., Wong, A. J., Matsuuchi, L., Gold, M. R. (2001). The Gab1 docking protein links the b cell antigen receptor to

- the phosphatidylinositol 3-kinase/Akt signaling pathway and to the SHP2 tyrosine phosphatase. *J Biol Chem* 276:12257-65.
- Ishiai, M., Kurosaki, M., Pappu, R., Okawa, K., Ronko, I., Fu, C., Shibata, M., Iwamatsu, A., Chan, A. C., Kurosaki, T. (1999). BLNK required for coupling Syk to PLC gamma 2 and Rac1-JNK in B cells. *Immunity* 10:117-25.
- Ishiai, M., Sugawara, H., Kurosaki, M., Kurosaki, T. (1999). Cutting edge: association of phospholipase C-gamma 2 Src homology 2 domains with BLNK is critical for B cell antigen receptor signaling. *J Immunol* 163:1746-9.
- Jacob, A., Cooney, D., Pradhan, M., Coggeshall, K. M. (2002). Convergence of signaling pathways on the activation of ERK in B cells. *J Biol Chem* 277:23420-6.
- Jacob, A., Cooney, D., Tridandapani, S., Kelley, T., Coggeshall, K. M. (1999). FcgammaRIIb modulation of surface immunoglobulin-induced Akt activation in murine B cells. *J Biol Chem* 274:13704-10.
- Jain, J., McCaffrey, P. G., Miner, Z., Kerppola, T. K., Lambert, J. N., Verdine, G. L., Curran, T., Rao, A. (1993). The T-cell transcription factor NFATp is a substrate for calcineurin and interacts with Fos and Jun. *Nature* 365:352-5.
- Janas, M. L., Hodgkin, P., Hibbs, M., Tarlinton, D. (1999). Genetic evidence for Lyn as a negative regulator of IL-4 signaling. *J Immunol* 163:4192-8.
- Jones, N., Dumont, D. J. (1999). Recruitment of Dok-R to the EGF receptor through its PTB domain is required for attenuation of Erk MAP kinase activation. *Curr Biol* 9:1057-60.
- Jou, S. T., Carpino, N., Takahashi, Y., Piekorz, R., Chao, J. R., Wang, D., Ihle, J. N. (2002). Essential, nonredundant role for the phosphoinositide 3-kinase p110delta in signaling by the B-cell receptor complex. *Mol Cell Biol* 22:8580-91.
- Kaisho, T., Schwenk, F., Rajewsky, K. (1997). The roles of gamma 1 heavy chain membrane expression and cytoplasmic tail in IgG1 responses. *Science* 276:412-5.
- Kapeller, R., Prasad, K. V., Janssen, O., Hou, W., Schaffhausen, B. S., Rudd, C. E., Cantley, L. C. (1994). Identification of two SH3-binding motifs in the regulatory subunit of phosphatidylinositol 3-kinase. *J Biol Chem* 269:1927-33.
- Karin, M., Ben-Neriah, Y. (2000). Phosphorylation meets ubiquitination: the control of NF-[kappa]B activity. *Annu Rev Immunol* 18:621-63.
- Karnitz, L. M., Sutor, S. L., Abraham, R. T. (1994). The Src-family kinase, Fyn, regulates the activation of phosphatidylinositol 3-kinase in an interleukin 2-responsive T cell line. *J Exp Med* 179:1799-808.
- Katagiri, K., Katagiri, T., Koyama, Y., Morikawa, M., Yamamoto, T., Yoshida, T. (1991). Expression of src family genes during monocytic differentiation of HL-60 cells. *J Immunol* 146:701-7.
- Katso, R., Okkenhaug, K., Ahmadi, K., White, S., Timms, J., Waterfield, M. D. (2001). Cellular function of phosphoinositide 3-kinases: implications for development, homeostasis, and cancer. *Annu Rev Cell Dev Biol* 17:615-75.
- Katsuta, H., Tsuji, S., Niho, Y., Kurosaki, T., Kitamura, D. (1998). Lyn-mediated down-regulation of B cell antigen receptor signaling: inhibition of protein kinase C activation by Lyn in a kinase-independent fashion. *J Immunol* 160:1547-51.
- Kawabuchi, M., Satomi, Y., Takao, T., Shimonishi, Y., Nada, S., Nagai, K., Tarakhovsky, A., Okada, M. (2000). Transmembrane phosphoprotein Cbp regulates the activities of Src-family tyrosine kinases. *Nature* 404:999-1003.

- Kawakami, Y., Yao, L., Miura, T., Tsukada, S., Witte, O. N., Kawakami, T. (1994). Tyrosine phosphorylation and activation of Bruton tyrosine kinase upon Fc epsilon RI cross-linking. *Mol Cell Biol* 14:5108-13.
- Kelm, S., Pelz, A., Schauer, R., Filbin, M. T., Tang, S., de Bellard, M. E., Schnaar, R. L., Mahoney, J. A., Hartnell, A., Bradfield, P., et al. (1994). Sialoadhesin, myelin-associated glycoprotein and CD22 define a new family of sialic acid-dependent adhesion molecules of the immunoglobulin superfamily. *Curr Biol* 4:965-72.
- Keshvara, L. M., Isaacson, C., Harrison, M. L., Geahlen, R. L. (1997). Syk activation and dissociation from the B-cell antigen receptor is mediated by phosphorylation of tyrosine 130. *J Biol Chem* 272:10377-81.
- Keshvara, L. M., Isaacson, C. C., Yankee, T. M., Sarac, R., Harrison, M. L., Geahlen, R. L. (1998). Syk- and Lyn-dependent phosphorylation of Syk on multiple tyrosines following B cell activation includes a site that negatively regulates signaling. *J Immunol* 161:5276-83.
- Khan, W. N., Alt, F. W., Gerstein, R. M., Malynn, B. A., Larsson, I., Rathbun, G., Davidson, L., Muller, S., Kantor, A. B., Herzenberg, L. A., et al. (1995). Defective B cell development and function in Btk-deficient mice. *Immunity* 3:283-99.
- Kiener, P. A., Lioubin, M. N., Rohrschneider, L. R., Ledbetter, J. A., Nadler, S. G., Diegel, M. L. (1997). Co-ligation of the antigen and Fc receptors gives rise to the selective modulation of intracellular signaling in B cells. Regulation of the association of phosphatidylinositol 3-kinase and inositol 5'-phosphatase with the antigen receptor complex. *J Biol Chem* 272:3838-44.
- Kimura, T., Sakamoto, H., Appella, E., Siraganian, R. P. (1996). Conformational changes induced in the protein tyrosine kinase p72syk by tyrosine phosphorylation or by binding of phosphorylated immunoreceptor tyrosine-based activation motif peptides. *Mol Cell Biol* 16:1471-8.
- Kincade, P. W., Lee, G., Sun, L., Watanabe, T. (1981). Monoclonal rat antibodies to murine IgM determinants. *J Immunol Methods* 42:17-26.
- Kitanaka, A., Ito, C., Coustan-Smith, E., Campana, D. (1997). CD38 ligation in human B cell progenitors triggers tyrosine phosphorylation of CD19 and association of CD19 with lyn and phosphatidylinositol 3-kinase. *J Immunol* 159:184-92.
- Klinghoffer, R. A., Duckworth, B., Valius, M., Cantley, L., Kazlauskas, A. (1996). Platelet-derived growth factor-dependent activation of phosphatidylinositol 3-kinase is regulated by receptor binding of SH2-domain-containing proteins which influence Ras activity. *Mol Cell Biol* 16:5905-14.
- Klippel, A., Escobedo, J. A., Hu, Q., Williams, L. T. (1993). A region of the 85-kilodalton (kDa) subunit of phosphatidylinositol 3-kinase binds the 110-kDa catalytic subunit in vivo. *Mol Cell Biol* 13:5560-6.
- Koch, C. A., Anderson, D., Moran, M. F., Ellis, C., Pawson, T. (1991). SH2 and SH3 domains: elements that control interactions of cytoplasmic signaling proteins. *Science* 252:668-74.
- Kodaki, T., Woscholski, R., Hallberg, B., Rodriguez-Viciana, P., Downward, J., Parker, P. J. (1994). The activation of phosphatidylinositol 3-kinase by Ras. *Curr Biol* 4:798-806.
- Koyama, S., Yu, H., Dalgarno, D. C., Shin, T. B., Zydowsky, L. D., Schreiber, S. L. (1993). Structure of the PI3K SH3 domain and analysis of the SH3 family. *Cell* 72:945-52.
- Kozono, Y., Abe, R., Kozono, H., Kelly, R. G., Azuma, T., Holers, V. M. (1998). Cross-linking CD21/CD35 or CD19 increases both B7-1 and B7-2 expression on murine splenic B cells. *J Immunol* 160:1565-72.
- Krop, I., Shaffer, A. L., Fearon, D. T., Schlissel, M. S. (1996). The signaling activity of murine CD19

is regulated during cell development. *J Immunol* 157:48-56.

Kubagawa, H., Burrows, P. D., Cooper, M. D. (1997). A novel pair of immunoglobulin-like receptors expressed by B cells and myeloid cells. *Proc Natl Acad Sci U S A* 94:5261-6.

Kubagawa, H., Chen, C. C., Ho, L. H., Shimada, T. S., Gartland, L., Mashburn, C., Uehara, T., Ravetch, J. V., Cooper, M. D. (1999). Biochemical nature and cellular distribution of the paired immunoglobulin-like receptors, PIR-A and PIR-B. *J Exp Med* 189:309-18.

Kumanogoh, A., Watanabe, C., Lee, I., Wang, X., Shi, W., Araki, H., Hirata, H., Iwahori, K., Uchida, J., Yasui, T., Matsumoto, M., Yoshida, K., Yakura, H., Pan, C., Parnes, J. R., Kikutani, H. (2000). Identification of CD72 as a lymphocyte receptor for the class IV semaphorin CD100: a novel mechanism for regulating B cell signaling. *Immunity* 13:621-31.

Kuroki, K., Tsuchiya, N., Tsao, B. P., Grossman, J. M., Fukazawa, T., Hagiwara, K., Kano, H., Takazoe, M., Iwata, T., Hashimoto, H., Tokunaga, K. (2002). Polymorphisms of human CD19 gene: possible association with susceptibility to systemic lupus erythematosus in Japanese. *Genes Immun* 3:S21-30.

Kurosaki, T. (1999). Genetic analysis of B cell antigen receptor signaling. *Annu Rev Immunol* 17:555-92.

Kurosaki, T. (2002). Regulation of B-cell signal transduction by adaptor proteins. *Nat Rev Immunol* 2:354-63.

Kurosaki, T., Okada, T. (2001). Regulation of phospholipase C-gamma2 and phosphoinositide 3-kinase pathways by adaptor proteins in B lymphocytes. *Int Rev Immunol* 20:697-711.

Kurosaki, T., Takata, M., Yamanashi, Y., Inazu, T., Taniguchi, T., Yamamoto, T., Yamamura, H. (1994). Syk activation by the Src-family tyrosine kinase in the B cell receptor signaling. *J Exp Med* 179:1725-9.

Kyriakis, J. M., App, H., Zhang, X. F., Banerjee, P., Brautigan, D. L., Rapp, U. R., Avruch, J. (1992). Raf-1 activates MAP kinase-kinase. *Nature* 358:417-21.

Lam, K. P., Kuhn, R., Rajewsky, K. (1997). In vivo ablation of surface immunoglobulin on mature B cells by inducible gene targeting results in rapid cell death. *Cell* 90:1073-83.

Lam, K. P., Rajewsky, K. (1999). B cell antigen receptor specificity and surface density together determine B-1 versus B-2 cell development. *J Exp Med* 190:471-7.

Lankester, A. C., van Schijndel, G. M., Rood, P. M., Verhoeven, A. J., van Lier, R. A. (1994). B cell antigen receptor cross-linking induces tyrosine phosphorylation and membrane translocation of a multimeric Shc complex that is augmented by CD19 co-ligation. *Eur J Immunol* 24:2818-25.

Law, C. L., Chandran, K. A., Sidorenko, S. P., Clark, E. A. (1996). Phospholipase C-gamma1 interacts with conserved phosphotyrosyl residues in the linker region of Syk and is a substrate for Syk. *Mol Cell Biol* 16:1305-15.

Law, C. L., Sidorenko, S. P., Chandran, K. A., Draves, K. E., Chan, A. C., Weiss, A., Edelhoff, S., Disteche, C. M., Clark, E. A. (1994). Molecular cloning of human Syk. A B cell protein-tyrosine kinase associated with the surface immunoglobulin M-B cell receptor complex. *J Biol Chem* 269:12310-9.

Law, C. L., Sidorenko, S. P., Chandran, K. A., Zhao, Z., Shen, S. H., Fischer, E. H., Clark, E. A. (1996). CD22 associates with protein tyrosine phosphatase 1C, Syk, and phospholipase C-gamma(1) upon B cell activation. *J Exp Med* 183:547-60.

Law, D. A., Chan, V.W., Datta, S.K., and DeFranco, A.L. (1993). B-cell antigen receptor motifs have redundant signalling capabilities and bind the tyrosine kinase PTK72, Lyn and Fyn. *Curr Biol* 3:645-657.

- Ledbetter, J. A., Herzenberg, L. A. (1979). Xenogeneic monoclonal antibodies to mouse lymphoid differentiation antigens. *Immunol Rev* 47:63-90.
- Leevers, S. J., Vanhaesebroeck, B., Waterfield, M. D. (1999). Signalling through phosphoinositide 3-kinases: the lipids take centre stage. *Curr Opin Cell Biol* 11:219-25.
- Lemmon, M. A., Ferguson, K. M. (1998). Pleckstrin homology domains. *Curr Top Microbiol Immunol* 228:39-74.
- Lenormand, P., Sardet, C., Pages, G., L'Allemain, G., Brunet, A., Pouyssegur, J. (1993). Growth factors induce nuclear translocation of MAP kinases (p42mapk and p44mapk) but not of their activator MAP kinase kinase (p45mapkk) in fibroblasts. *J Cell Biol* 122:1079-88.
- Levine, Y. K., Wilkins, M. H. (1971). Structure of oriented lipid bilayers. *Nat New Biol* 230:69-72.
- Lewis, C. M., Broussard, C., Czar, M. J., Schwartzberg, P. L. (2001). Tec kinases: modulators of lymphocyte signaling and development. *Curr Opin Immunol* 13:317-25.
- Ley, T. J., Connolly, N. L., Katamine, S., Cheah, M. S., Senior, R. M., Robbins, K. C. (1989). Tissue-specific expression and developmental regulation of the human fgr proto-oncogene. *Mol Cell Biol* 9:92-9.
- Li, H. L., Davis, W. W., Whiteman, E. L., Birnbaum, M. J., Pure, E. (1999). The tyrosine kinases Syk and Lyn exert opposing effects on the activation of protein kinase Akt/PKB in B lymphocytes. *Proc Natl Acad Sci U S A* 96:6890-5.
- Li, P., Nijhawan, D., Budihardjo, I., Srinivasula, S. M., Ahmad, M., Alnemri, E. S., Wang, X. (1997). Cytochrome c and dATP-dependent formation of Apaf-1/caspase-9 complex initiates an apoptotic protease cascade. *Cell* 91:479-89.
- Li, T., Rawlings, D. J., Park, H., Kato, R. M., Witte, O. N., Satterthwaite, A. B. (1997). Constitutive membrane association potentiates activation of Bruton tyrosine kinase. *Oncogene* 15:1375-83.
- Li, T., Tsukada, S., Satterthwaite, A., Havlik, M. H., Park, H., Takatsu, K., Witte, O. N. (1995). Activation of Bruton's tyrosine kinase (BTK) by a point mutation in its pleckstrin homology (PH) domain. *Immunity* 2:451-60.
- Li, X., Carter, R. H. (1998). Convergence of CD19 and B cell antigen receptor signals at MEK1 in the ERK2 activation cascade. *J Immunol* 161:5901-8.
- Li, X., Carter, R. H. (2000). CD19 signal transduction in normal human B cells: linkage to downstream pathways requires phosphatidylinositol 3-kinase, protein kinase C and Ca²⁺. *Eur J Immunol* 30:1576-86.
- Li, X., Sandoval, D., Freeberg, L., Carter, R. H. (1997). Role of CD19 tyrosine 391 in synergistic activation of B lymphocytes by coligation of CD19 and membrane Ig. *J Immunol* 158:5649-57.
- Li, Z., Wahl, M. I., Eguinoa, A., Stephens, L. R., Hawkins, P. T., Witte, O. N. (1997). Phosphatidylinositol 3-kinase-gamma activates Bruton's tyrosine kinase in concert with Src family kinases. *Proc Natl Acad Sci U S A* 94:13820-5.
- Lim, W. A., Richards, F. M., Fox, R. O. (1994). Structural determinants of peptide-binding orientation and of sequence specificity in SH3 domains. *Nature* 372:375-9.
- Link, D. C., Zutter, M. (1995). The proto-oncogene c-fgr is expressed in normal mantle zone B lymphocytes and is developmentally regulated during myelomonocytic differentiation in vivo. *Blood* 85:472-9.
- Liossis, S. N., Solomou, E. E., Dimopoulos, M. A., Panayiotidis, P., Mavrikakis, M. M., Sfrikakis, P. P.

- (2001). B-cell kinase lyn deficiency in patients with systemic lupus erythematosus. *J Investig Med* 49:157-65.
- Liu, Y., Wang, Y., Yamakuchi, M., Masuda, S., Tokioka, T., Yamaoka, S., Maruyama, I., Kitajima, I. (2001). Phosphoinositide-3 kinase-PKB/Akt pathway activation is involved in fibroblast Rat-1 transformation by human T-cell leukemia virus type I tax. *Oncogene* 20:2514-26.
- Lock, P., Casagrande, F., Dunn, A. R. (1999). Independent SH2-binding sites mediate interaction of Dok-related protein with RasGTPase-activating protein and Nck. *J Biol Chem* 274:22775-84.
- Loder, F., Mutschler, B., Ray, R. J., Paige, C. J., Sideras, P., Torres, R., Lamers, M. C., Carsetti, R. (1999). B cell development in the spleen takes place in discrete steps and is determined by the quality of B cell receptor-derived signals. *J Exp Med* 190:75-89.
- Lopez-Illasaca, M., Crespo, P., Pellici, P. G., Gutkind, J. S., Wetzker, R. (1997). Linkage of G protein-coupled receptors to the MAPK signaling pathway through PI 3-kinase gamma. *Science* 275:394-7.
- Lupher, M. L., Jr., Rao, N., Lill, N. L., Andoniou, C. E., Miyake, S., Clark, E. A., Druker, B., Band, H. (1998). Cbl-mediated negative regulation of the Syk tyrosine kinase. A critical role for Cbl phosphotyrosine-binding domain binding to Syk phosphotyrosine 323. *J Biol Chem* 273:35273-81.
- Ma, H., Yankee, T. M., Hu, J., Asai, D. J., Harrison, M. L., Geahlen, R. L. (2001). Visualization of Syk-antigen receptor interactions using green fluorescent protein: differential roles for Syk and Lyn in the regulation of receptor capping and internalization. *J Immunol* 166:1507-16.
- Maas, A., Hendriks, R. W. (2001). Role of Bruton's tyrosine kinase in B cell development. *Dev Immunol* 8:171-81.
- MacDougall, L. K., Domin, J., Waterfield, M. D. (1995). A family of phosphoinositide 3-kinases in *Drosophila* identifies a new mediator of signal transduction. *Curr Biol* 5:1404-15.
- Maecker, H. T., Todd, S. C., Levy, S. (1997). The tetraspanin superfamily: molecular facilitators. *Faseb J* 11:428-42.
- Maeda, A., Kurosaki, M., Ono, M., Takai, T., Kurosaki, T. (1998). Requirement of SH2-containing protein tyrosine phosphatases SHP-1 and SHP-2 for paired immunoglobulin-like receptor B (PIR-B)-mediated inhibitory signal. *J Exp Med* 187:1355-60.
- Maeda, A., Scharenberg, A. M., Tsukada, S., Bolen, J. B., Kinet, J. P., Kurosaki, T. (1999). Paired immunoglobulin-like receptor B (PIR-B) inhibits BCR-induced activation of Syk and Btk by SHP-1. *Oncogene* 18:2291-7.
- Mahajan, S., Vassilev, A., Sun, N., Ozer, Z., Mao, C., Uckun, F. M. (2001). Transcription factor STAT5A is a substrate of Bruton's tyrosine kinase in B cells. *J Biol Chem* 276:31216-28.
- Malbec, O., Fridman, W. H., Dairon, M. (1999a). Negative regulation of c-kit-mediated cell proliferation by Fc gamma RIIB. *J Immunol* 162:4424-9.
- Malbec, O., Fridman, W. H., Dairon, M. (1999b). Negative regulation of hematopoietic cell activation and proliferation by Fc gamma RIIB. *Curr Top Microbiol Immunol* 244:13-27.
- Malek, T. R., Robb, R. J., Shevach, E. M. (1983). Identification and initial characterization of a rat monoclonal antibody reactive with the murine interleukin 2 receptor-ligand complex. *Proc Natl Acad Sci U S A* 80:5694-8.
- Maltzman, J. S., Carman, J. A., Monroe, J. G. (1996a). Role of EGR1 in regulation of stimulus-dependent CD44 transcription in B lymphocytes. *Mol Cell Biol* 16:2283-94.
- Maltzman, J. S., Carman, J. A., Monroe, J. G. (1996b). Transcriptional regulation of the Icam-1 gene in antigen receptor- and phorbol ester-stimulated B lymphocytes: role for transcription factor EGR1. *J*

Exp Med 183:1747-59.

Mano, H., Ishikawa, F., Nishida, J., Hirai, H., Takaku, F. (1990). A novel protein-tyrosine kinase, tec, is preferentially expressed in liver. *Oncogene* 5:1781-6.

Mano, H., Mano, K., Tang, B., Koehler, M., Yi, T., Gilbert, D. J., Jenkins, N. A., Copeland, N. G., Ihle, J. N. (1993). Expression of a novel form of Tec kinase in hematopoietic cells and mapping of the gene to chromosome 5 near Kit. *Oncogene* 8:417-24.

Mano, H., Sato, K., Yazaki, Y., Hirai, H. (1994). Tec protein-tyrosine kinase directly associates with Lyn protein-tyrosine kinase through its N-terminal unique domain. *Oncogene* 9:3205-11.

Marshall, A. J., Niiro, H., Lerner, C. G., Yun, T. J., Thomas, S., Distech, C. M., Clark, E. A. (2000). A novel B lymphocyte-associated adaptor protein, Bam32, regulates antigen receptor signaling downstream of phosphatidylinositol 3-kinase. *J Exp Med* 191:1319-32.

Marshall, A. J., Niiro, H., Yun, T. J., Clark, E. A. (2000). Regulation of B-cell activation and differentiation by the phosphatidylinositol 3-kinase and phospholipase Cgamma pathway. *Immunol Rev* 176:30-46.

Marte, B. M., Rodriguez-Viciano, P., Wennstrom, S., Warne, P. H., Downward, J. (1997). R-Ras can activate the phosphoinositide 3-kinase but not the MAP kinase arm of the Ras effector pathways. *Curr Biol* 7:63-70.

Martin, F., Kearney, J. F. (2000). Positive selection from newly formed to marginal zone B cells depends on the rate of clonal production, CD19, and btk. *Immunity* 12:39-49.

Martin, S. W., Goodnow, C. C. (2002). Burst-enhancing role of the IgG membrane tail as a molecular determinant of memory. *Nat Immunol* 3:182-8.

Matsumoto, A. K., Martin, D. R., Carter, R. H., Klickstein, L. B., Ahearn, J. M., Fearon, D. T. (1993). Functional dissection of the CD21/CD19/TAPA-1/Leu-13 complex of B lymphocytes. *J Exp Med* 178:1407-17.

McCormick, F. (1994). Activators and effectors of ras p21 proteins. *Curr Opin Genet Dev* 4:71-6.

Meier, R., Alessi, D. R., Cron, P., Andjelkovic, M., Hemmings, B. A. (1997). Mitogenic activation, phosphorylation, and nuclear translocation of protein kinase Bbeta. *J Biol Chem* 272:30491-7.

Mizuno, K., Tagawa, Y., Mitomo, K., Arimura, Y., Hatano, N., Katagiri, T., Ogimoto, M., Yakura, H. (2000). Src homology region 2 (SH2) domain-containing phosphatase-1 dephosphorylates B cell linker protein/SH2 domain leukocyte protein of 65 kDa and selectively regulates c-Jun NH2-terminal kinase activation in B cells. *J Immunol* 165:1344-51.

Mohamed, A. J., Vargas, L., Nore, B. F., Backesjo, C. M., Christensson, B., Smith, C. I. (2000). Nucleocytoplasmic shuttling of Bruton's tyrosine kinase. *J Biol Chem* 275:40614-9.

Muta, T., Kurosaki, T., Misulovin, Z., Sanchez, M., Nussenzweig, M. C., Ravetch, J. V. (1994). A 13-amino-acid motif in the cytoplasmic domain of Fc gamma RIIB modulates B-cell receptor signalling. *Nature* 368:70-3.

Myers, D. E., Jun, X., Waddick, K. G., Forsyth, C., Chelstrom, L. M., Gunther, R. L., Tumer, N. E., Bolen, J., Uckun, F. M. (1995). Membrane-associated CD19-LYN complex is an endogenous p53-independent and Bcl-2-independent regulator of apoptosis in human B-lineage lymphoma cells. *Proc Natl Acad Sci U S A* 92:9575-9.

Nadler, M. J., Chen, B., Anderson, J. S., Wortis, H. H., Neel, B. G. (1997). Protein-tyrosine phosphatase SHP-1 is dispensable for Fc gamma RIIB-mediated inhibition of B cell antigen receptor activation. *J Biol Chem* 272:20038-43.

- Nakayama, E., von Hoegen, I., Parnes, J. R. (1989). Sequence of the Lyb-2 B-cell differentiation antigen defines a gene superfamily of receptors with inverted membrane orientation. *Proc Natl Acad Sci U S A* 86:1352-6.
- Naramura, M., Kole, H. K., Hu, R. J., Gu, H. (1998). Altered thymic positive selection and intracellular signals in Cbl- deficient mice. *Proc Natl Acad Sci U S A* 95:15547-52.
- Nemazee, D. A., Burki, K. (1989). Clonal deletion of B lymphocytes in a transgenic mouse bearing anti-MHC class I antibody genes. *Nature* 337:562-6.
- Niuro, H., Maeda, A., Kurosaki, T., Clark, E. A. (2002). The B lymphocyte adaptor molecule of 32 kD (Bam32) regulates B cell antigen receptor signaling and cell survival. *J Exp Med* 195:143-9.
- Nishizumi, H., Horikawa, K., Mlinaric-Rascan, I., Yamamoto, T. (1998). A double-edged kinase Lyn: a positive and negative regulator for antigen receptor-mediated signals. *J Exp Med* 187:1343-8.
- Nishizumi, H., Taniuchi, I., Yamanashi, Y., Kitamura, D., Ilic, D., Mori, S., Watanabe, T., Yamamoto, T. (1995). Impaired proliferation of peripheral B cells and indication of autoimmune disease in lyn-deficient mice. *Immunity* 3:549-60.
- Nisitani, S., Kato, R. M., Rawlings, D. J., Witte, O. N., Wahl, M. I. (1999). In situ detection of activated Bruton's tyrosine kinase in the Ig signaling complex by phosphopeptide-specific monoclonal antibodies. *Proc Natl Acad Sci U S A* 96:2221-6.
- Nitschke, L., Carsetti, R., Ocker, B., Kohler, G., Lamers, M. C. (1997). CD22 is a negative regulator of B-cell receptor signalling. *Curr Biol* 7:133-43.
- Nossal, G. J. (1983). Cellular mechanisms of immunologic tolerance. *Annu Rev Immunol* 1:33-62.
- O'Keefe, T. L., Williams, G. T., Davies, S. L., Neuberger, M. S. (1996). Hyperresponsive B cells in CD22-deficient mice. *Science* 274:798-801.
- O'Rourke, L. M., Tooze, R., Turner, M., Sandoval, D. M., Carter, R. H., Tybulewicz, V. L., Fearon, D. T. (1998). CD19 as a membrane-anchored adaptor protein of B lymphocytes: costimulation of lipid and protein kinases by recruitment of Vav. *Immunity* 8:635-45.
- Ohtake, H., Ichikawa, N., Okada, M., Yamashita, T. (2002). Cutting Edge: Transmembrane phosphoprotein Csk-binding protein/phosphoprotein associated with glycosphingolipid-enriched microdomains as a negative feedback regulator of mast cell signaling through the FcepsilonRI. *J Immunol* 168:2087-90.
- Okada, M., Nada, S., Yamanashi, Y., Yamamoto, T., Nakagawa, H. (1991). CSK: a protein-tyrosine kinase involved in regulation of src family kinases. *J Biol Chem* 266:24249-52.
- Okada, T., Maeda, A., Iwamatsu, A., Gotoh, K., Kurosaki, T. (2000). BCAP: the tyrosine kinase substrate that connects B cell receptor to phosphoinositide 3-kinase activation. *Immunity* 13:817-27.
- Okazaki, T., Maeda, A., Nishimura, H., Kurosaki, T., Honjo, T. (2001). PD-1 immunoreceptor inhibits B cell receptor-mediated signaling by recruiting src homology 2-domain-containing tyrosine phosphatase 2 to phosphotyrosine. *Proc Natl Acad Sci U S A* 98:13866-71.
- Okkenhaug, K., Bilancio, A., Farjot, G., Priddle, H., Sancho, S., Peskett, E., Pearce, W., Meek, S. E., Salpekar, A., Waterfield, M. D., Smith, A. J., Vanhaesebroeck, B. (2002). Impaired B and T cell antigen receptor signaling in p110delta PI 3-kinase mutant mice. *Science* 297:1031-4.
- Okkenhaug, K., Vanhaesebroeck, B. (2003). PI3K in lymphocyte development, differentiation and activation. *Nat Rev Immunol* 3:317-30.
- Ono, M., Bolland, S., Tempst, P., Ravetch, J. V. (1996). Role of the inositol phosphatase SHIP in negative regulation of the immune system by the receptor Fc(gamma)RIIB. *Nature* 383:263-6.

- Ono, M., Okada, H., Bolland, S., Yanagi, S., Kurosaki, T., Ravetch, J. V. (1997). Deletion of SHIP or SHP-1 reveals two distinct pathways for inhibitory signaling. *Cell* 90:293-301.
- Otero, D. C., Anzelon, A. N., Rickert, R. C. (2003). CD19 function in early and late B cell development: I. Maintenance of follicular and marginal zone B cells requires CD19-dependent survival signals. *J Immunol* 170:73-83.
- Otero, D. C., Omori, S. A., Rickert, R. C. (2001). Cd19-dependent activation of Akt kinase in B-lymphocytes. *J Biol Chem* 276:1474-8.
- Otipoby, K. L., Andersson, K. B., Draves, K. E., Klaus, S. J., Farr, A. G., Kerner, J. D., Perlmutter, R. M., Law, C. L., Clark, E. A. (1996). CD22 regulates thymus-independent responses and the lifespan of B cells. *Nature* 384:634-7.
- Pages, G., Lenormand, P., L'Allemain, G., Chambard, J. C., Meloche, S., Pouyssegur, J. (1993). Mitogen-activated protein kinases p42mapk and p44mapk are required for fibroblast proliferation. *Proc Natl Acad Sci U S A* 90:8319-23.
- Pan, C., Baumgarth, N., Parnes, J. R. (1999). CD72-deficient mice reveal nonredundant roles of CD72 in B cell development and activation. *Immunity* 11:495-506.
- Panayotou, G., Gish, G., End, P., Truong, O., Gout, I., Dhand, R., Fry, M. J., Hiles, I., Pawson, T., Waterfield, M. D. (1993). Interactions between SH2 domains and tyrosine-phosphorylated platelet-derived growth factor beta-receptor sequences: analysis of kinetic parameters by a novel biosensor-based approach. *Mol Cell Biol* 13:3567-76.
- Pao, L. I., Cambier, J. C. (1997). Syk, but not Lyn, recruitment to B cell antigen receptor and activation following stimulation of CD45- B cells. *J Immunol* 158:2663-9.
- Pao, L. I., Famiglietti, S. J., Cambier, J. C. (1998). Asymmetrical phosphorylation and function of immunoreceptor tyrosine-based activation motif tyrosines in B cell antigen receptor signal transduction. *J Immunol* 160:3305-14.
- Parekh, A. B., Fleig, A., Penner, R. (1997). The store-operated calcium current I(CRAC): nonlinear activation by InsP3 and dissociation from calcium release. *Cell* 89:973-80.
- Parravicini, V., Gadina, M., Kovarova, M., Odom, S., Gonzalez-Espinosa, C., Furumoto, Y., Saitoh, S., Samelson, L. E., O'Shea, J. J., Rivera, J. (2002). Fyn kinase initiates complementary signals required for IgE-dependent mast cell degranulation. *Nat Immunol* 3:741-8.
- Parton, R. G., Simons, K. (1995). Digging into caveolae. *Science* 269:1398-9.
- Pawson, T., Gish, G. D. (1992). SH2 and SH3 domains: from structure to function. *Cell* 71:359-62.
- Peaker, C. J., Neuberger, M. S. (1993). Association of CD22 with the B cell antigen receptor. *Eur J Immunol* 23:1358-63.
- Pei, D., Lorenz, U., Klingmuller, U., Neel, B. G., Walsh, C. T. (1994). Intramolecular regulation of protein tyrosine phosphatase SH-PTP1: a new function for Src homology 2 domains. *Biochemistry* 33:15483-93.
- Petrie, R. J., Schnetkamp, P. P., Patel, K. D., Awasthi-Kalia, M., Deans, J. P. (2000). Transient translocation of the B cell receptor and Src homology 2 domain-containing inositol phosphatase to lipid rafts: evidence toward a role in calcium regulation. *J Immunol* 165:1220-7.
- Pezzutto, A., Dorken, B., Rabinovitch, P. S., Ledbetter, J. A., Moldenhauer, G., Clark, E. A. (1987). CD19 monoclonal antibody HD37 inhibits anti-immunoglobulin-induced B cell activation and proliferation. *J Immunol* 138:2793-9.

- Phillips, N. E., Parker, D. C. (1984). Cross-linking of B lymphocyte Fc gamma receptors and membrane immunoglobulin inhibits anti-immunoglobulin-induced blastogenesis. *J Immunol* 132:627-32.
- Pirola, L., Zvelebil, M. J., Bulgarelli-Leva, G., Van Obberghen, E., Waterfield, M. D., Wymann, M. P. (2001). Activation loop sequences confer substrate specificity to phosphoinositide 3-kinase alpha (PI3Kalpha). Functions of lipid kinase-deficient PI3Kalpha in signaling. *J Biol Chem* 276:21544-54.
- Pleiman, C. M., Hertz, W. M., Cambier, J. C. (1994). Activation of phosphatidylinositol-3' kinase by Src-family kinase SH3 binding to the p85 subunit. *Science* 263:1609-12.
- Prasad, K. V., Janssen, O., Kapeller, R., Raab, M., Cantley, L. C., Rudd, C. E. (1993). Src-homology 3 domain of protein kinase p59fyn mediates binding to phosphatidylinositol 3-kinase in T cells. *Proc Natl Acad Sci U S A* 90:7366-70.
- Prior, I. A., Clague, M. J. (1999). Localization of a class II phosphatidylinositol 3-kinase, PI3KC2alpha, to clathrin-coated vesicles. *Mol Cell Biol Res Commun* 1:162-6.
- Putney, J. W., Jr., Bird, G. S. (1993). The signal for capacitative calcium entry. *Cell* 75:199-201.
- Quintrell, N., Lebo, R., Varmus, H., Bishop, J. M., Pettenati, M. J., Le Beau, M. M., Diaz, M. O., Rowley, J. D. (1987). Identification of a human gene (HCK) that encodes a protein-tyrosine kinase and is expressed in hemopoietic cells. *Mol Cell Biol* 7:2267-75.
- Rameh, L. E., Arvidsson, A., Carraway, K. L., 3rd, Couvillon, A. D., Rathbun, G., Crompton, A., VanRenterghem, B., Czech, M. P., Ravichandran, K. S., Burakoff, S. J., Wang, D. S., Chen, C. S., Cantley, L. C. (1997). A comparative analysis of the phosphoinositide binding specificity of pleckstrin homology domains. *J Biol Chem* 272:22059-66.
- Rao, N., Dodge, I., Band, H. (2002). The Cbl family of ubiquitin ligases: critical negative regulators of tyrosine kinase signaling in the immune system. *J Leukoc Biol* 71:753-63.
- Rao, N., Miyake, S., Reddi, A. L., Douillard, P., Ghosh, A. K., Dodge, I. L., Zhou, P., Fernandes, N. D., Band, H. (2002). Negative regulation of Lck by Cbl ubiquitin ligase. *Proc Natl Acad Sci U S A* 99:3794-9.
- Rawlings, D. J. (1999). Bruton's tyrosine kinase controls a sustained calcium signal essential for B lineage development and function. *Clin Immunol* 91:243-53.
- Rawlings, D. J., Saffran, D. C., Tsukada, S., Largaespada, D. A., Grimaldi, J. C., Cohen, L., Mohr, R. N., Bazan, J. F., Howard, M., Copeland, N. G., et al. (1993). Mutation of unique region of Bruton's tyrosine kinase in immunodeficient XID mice. *Science* 261:358-61.
- Rawlings, D. J., Scharenberg, A. M., Park, H., Wahl, M. I., Lin, S., Kato, R. M., Fluckiger, A. C., Witte, O. N., Kinet, J. P. (1996). Activation of BTK by a phosphorylation mechanism initiated by SRC family kinases. *Science* 271:822-5.
- Resh, M. D. (1994). Myristylation and palmitoylation of Src family members: the fats of the matter. *Cell* 76:411-3.
- Reth, M. (1989). Antigen receptor tail clue. *Nature* 338:383-4.
- Reth, M. (1992). Antigen receptors on B lymphocytes. *Annu Rev Immunol* 10:97-121.
- Richard, S., Yu, D., Blumer, K. J., Hausladen, D., Olszowy, M. W., Connelly, P. A., Shaw, A. S. (1995). Association of p62, a multifunctional SH2- and SH3-domain-binding protein, with src family tyrosine kinases, Grb2, and phospholipase C gamma-1. *Mol Cell Biol* 15:186-97.
- Richards, J. D., Dave, S. H., Chou, C. H., Mamchak, A. A., DeFranco, A. L. (2001). Inhibition of the MEK/ERK signaling pathway blocks a subset of B cell responses to antigen. *J Immunol* 166:3855-64.

- Richards, J. D., Gold, M. R., Hourihane, S. L., DeFranco, A. L., Matsuuchi, L. (1996). Reconstitution of B cell antigen receptor-induced signaling events in a nonlymphoid cell line by expressing the Syk protein-tyrosine kinase. *J Biol Chem* 271:6458-66.
- Rickert, R. C., Rajewsky, K., Roes, J. (1995). Impairment of T-cell-dependent B-cell responses and B-1 cell development in CD19-deficient mice. *Nature* 376:352-5.
- Roberts, T., Snow, E. C. (1999). Cutting edge: recruitment of the CD19/CD21 coreceptor to B cell antigen receptor is required for antigen-mediated expression of Bcl-2 by resting and cycling hen egg lysozyme transgenic B cells. *J Immunol* 162:4377-80.
- Rodgers, W., Rose, J. K. (1996). Exclusion of CD45 inhibits activity of p56lck associated with glycolipid-enriched membrane domains. *J Cell Biol* 135:1515-23.
- Rodriguez-Viciano, P., Warne, P. H., Dhand, R., Vanhaesebroeck, B., Gout, I., Fry, M. J., Waterfield, M. D., Downward, J. (1994). Phosphatidylinositol-3-OH kinase as a direct target of Ras. *Nature* 370:527-32.
- Rodriguez-Viciano, P., Warne, P. H., Vanhaesebroeck, B., Waterfield, M. D., Downward, J. (1996). Activation of phosphoinositide 3-kinase by interaction with Ras and by point mutation. *Embo J* 15:2442-51.
- Roifman, C. M., Ke, S. (1993). CD19 is a substrate of the antigen receptor-associated protein tyrosine kinase in human B cells. *Biochem Biophys Res Commun* 194:222-5.
- Rolli, V., Gallwitz, M., Wossning, T., Flemming, A., Schamel, W. W., Zurn, C., Reth, M. (2002). Amplification of B cell antigen receptor signaling by a Syk/ITAM positive feedback loop. *Mol Cell* 10:1057-69.
- Rott, O., Cash, E. (1994). Influenza virus hemagglutinin induces differentiation of mature resting B cells and growth arrest of immature WEHI-231 lymphoma cells. *J Immunol* 152:5381-91.
- Rowley, R. B., Burkhardt, A. L., Chao, H. G., Matsueda, G. R., Bolen, J. B. (1995). Syk protein-tyrosine kinase is regulated by tyrosine-phosphorylated Ig alpha/Ig beta immunoreceptor tyrosine activation motif binding and autophosphorylation. *J Biol Chem* 270:11590-4.
- Roy, A. L., Du, H., Gregor, P. D., Novina, C. D., Martinez, E., Roeder, R. G. (1997). Cloning of an inr- and E-box-binding protein, TFII-I, that interacts physically and functionally with USF1. *Embo J* 16:7091-104.
- Saijo, K., Schmedt, C., Su, I. H., Karasuyama, H., Lowell, C. A., Reth, M., Adachi, T., Patke, A., Santana, A., Tarakhovskiy, A. (2003). Essential role of Src-family protein tyrosine kinases in NF-kappaB activation during B cell development. *Nat Immunol* 4:274-9.
- Saito, K., Scharenberg, A. M., Kinet, J. P. (2001). Interaction between the Btk PH domain and phosphatidylinositol-3,4,5-trisphosphate directly regulates Btk. *J Biol Chem* 276:16201-6.
- Sakaguchi, N., Kashiwamura, S., Kimoto, M., Thalmann, P., Melchers, F. (1988). B lymphocyte lineage-restricted expression of mb-1, a gene with CD3-like structural properties. *Embo J* 7:3457-64.
- Salim, K., Bottomley, M. J., Querfurth, E., Zvelebil, M. J., Gout, I., Scaife, R., Margolis, R. L., Gigg, R., Smith, C. I., Driscoll, P. C., Waterfield, M. D., Panayotou, G. (1996). Distinct specificity in the recognition of phosphoinositides by the pleckstrin homology domains of dynamin and Bruton's tyrosine kinase. *Embo J* 15:6241-50.
- Samelson, L. E., Phillips, A. F., Luong, E. T., Klausner, R. D. (1990). Association of the fyn protein-tyrosine kinase with the T-cell antigen receptor. *Proc Natl Acad Sci U S A* 87:4358-62.
- Sanchez, M., Misulovin, Z., Burkhardt, A. L., Mahajan, S., Costa, T., Franke, R., Bolen, J. B.,

- Nussenzweig, M. (1993). Signal transduction by immunoglobulin is mediated through Ig alpha and Ig beta. *J Exp Med* 178:1049-55.
- Saouaf, S. J., Burkhardt, A. L., Bolen, J. B. (1995). Nonreceptor protein tyrosine kinase involvement in signal transduction and immunodeficiency disease. *Clin Immunol Immunopathol* 76:S151-7.
- Saouaf, S. J., Mahajan, S., Rowley, R. B., Kut, S. A., Fargnoli, J., Burkhardt, A. L., Tsukada, S., Witte, O. N., Bolen, J. B. (1994). Temporal differences in the activation of three classes of non-transmembrane protein tyrosine kinases following B-cell antigen receptor surface engagement. *Proc Natl Acad Sci U S A* 91:9524-8.
- Sarmay, G., Koncz, G., Pecht, I., Gergely, J. (1997). Fc gamma receptor type IIb induced recruitment of inositol and protein phosphatases to the signal transducing complex of human B-cell. *Immunol Lett* 57:159-64.
- Sarmiento, M., Glasebrook, A. L., Fitch, F. W. (1980). IgG or IgM monoclonal antibodies reactive with different determinants on the molecular complex bearing Lyt 2 antigen block T cell-mediated cytotoxicity in the absence of complement. *J Immunol* 125:2665-72.
- Sasaki, T., Suzuki, A., Sasaki, J., Penninger, J. M. (2002). Phosphoinositide 3-kinases in immunity: lessons from knockout mice. *J Biochem (Tokyo)* 131:495-501.
- Sato, H., Boyse, E.A. (1976). A new alloantigen expressed selectively on B cells: the Lyb-2 system. *Immunogenetics* 3:565-572.
- Sato, S., Hasegawa, M., Fujimoto, M., Tedder, T. F., Takehara, K. (2000). Quantitative genetic variation in CD19 expression correlates with autoimmunity. *J Immunol* 165:6635-43.
- Sato, S., Miller, A. S., Howard, M. C., Tedder, T. F. (1997). Regulation of B lymphocyte development and activation by the CD19/CD21/CD81/Leu 13 complex requires the cytoplasmic domain of CD19. *J Immunol* 159:3278-87.
- Sato, S., Miller, A. S., Inaoki, M., Bock, C. B., Jansen, P. J., Tang, M. L., Tedder, T. F. (1996). CD22 is both a positive and negative regulator of B lymphocyte antigen receptor signal transduction: altered signaling in CD22-deficient mice. *Immunity* 5:551-62.
- Sato, S., Ono, N., Steeber, D. A., Pisetsky, D. S., Tedder, T. F. (1996). CD19 regulates B lymphocyte signaling thresholds critical for the development of B-1 lineage cells and autoimmunity. *J Immunol* 157:4371-8.
- Sato, S., Steeber, D. A., Jansen, P. J., Tedder, T. F. (1997). CD19 expression levels regulate B lymphocyte development: human CD19 restores normal function in mice lacking endogenous CD19. *J Immunol* 158:4662-9.
- Sato, S., Steeber, D. A., Tedder, T. F. (1995). The CD19 signal transduction molecule is a response regulator of B-lymphocyte differentiation. *Proc Natl Acad Sci U S A* 92:11558-62.
- Saxton, T. M., van Oostveen, I., Bowtell, D., Aebersold, R., Gold, M. R. (1994). B cell antigen receptor cross-linking induces phosphorylation of the p21ras oncoprotein activators SHC and mSOS1 as well as assembly of complexes containing SHC, GRB-2, mSOS1, and a 145-kDa tyrosine-phosphorylated protein. *J Immunol* 153:623-36.
- Schamel, W. W., Reth, M. (2000). Monomeric and oligomeric complexes of the B cell antigen receptor. *Immunity* 13:5-14.
- Scharenberg, A. M., El-Hillal, O., Fruman, D. A., Beitz, L. O., Li, Z., Lin, S., Gout, I., Cantley, L. C., Rawlings, D. J., Kinet, J. P. (1998). Phosphatidylinositol-3,4,5-trisphosphate (PtdIns-3,4,5-P3)/Tec kinase-dependent calcium signaling pathway: a target for SHIP-mediated inhibitory signals. *Embo J* 17:1961-72.

- Schmitz, R., Baumann, G., Gram, H. (1996). Catalytic specificity of phosphotyrosine kinases Blk, Lyn, c-Src and Syk as assessed by phage display. *J Mol Biol* 260:664-77.
- Schulte, R. J., Campbell, M. A., Fischer, W. H., Sefton, B. M. (1992). Tyrosine phosphorylation of CD22 during B cell activation. *Science* 258:1001-4.
- Schweighoffer, E., Vanes, L., Mathiot, A., Nakamura, T., Tybulewicz, V. L. (2003). Unexpected requirement for ZAP-70 in pre-B cell development and allelic exclusion. *Immunity* 18:523-33.
- Settleman, J., Albright, C. F., Foster, L. C., Weinberg, R. A. (1992). Association between GTPase activators for Rho and Ras families. *Nature* 359:153-4.
- Shaw, A. S., Amrein, K. E., Hammond, C., Stern, D. F., Sefton, B. M., Rose, J. K. (1989). The lck tyrosine protein kinase interacts with the cytoplasmic tail of the CD4 glycoprotein through its unique amino-terminal domain. *Cell* 59:627-36.
- Shinkai, Y., Rathbun, G., Lam, K. P., Oltz, E. M., Stewart, V., Mendelsohn, M., Charron, J., Datta, M., Young, F., Stall, A. M., et al. (1992). RAG-2-deficient mice lack mature lymphocytes owing to inability to initiate V(D)J rearrangement. *Cell* 68:855-67.
- Sicheri, F., Moarefi, I., Kuriyan, J. (1997). Crystal structure of the Src family tyrosine kinase Hck. *Nature* 385:602-9.
- Sicilia, R. J., Hibbs, M. L., Bello, P. A., Bjorge, J. D., Fujita, D. J., Stanley, I. J., Dunn, A. R., Cheng, H. C. (1998). Common in vitro substrate specificity and differential Src homology 2 domain accessibility displayed by two members of the Src family of protein-tyrosine kinases, c-Src and Hck. *J Biol Chem* 273:16756-63.
- Sidorenko, S. P., Law, C. L., Chandran, K. A., Clark, E. A. (1995). Human spleen tyrosine kinase p72Syk associates with the Src-family kinase p53/56Lyn and a 120-kDa phosphoprotein. *Proc Natl Acad Sci U S A* 92:359-63.
- Sidorenko, S. P., Law, C. L., Klaus, S. J., Chandran, K. A., Takata, M., Kurosaki, T., Clark, E. A. (1996). Protein kinase C mu (PKC mu) associates with the B cell antigen receptor complex and regulates lymphocyte signaling. *Immunity* 5:353-63.
- Siliciano, J. D., Morrow, T. A., Desiderio, S. V. (1992). itk, a T-cell-specific tyrosine kinase gene inducible by interleukin 2. *Proc Natl Acad Sci U S A* 89:11194-8.
- Simons, K., Ikonen, E. (1997). Functional rafts in cell membranes. *Nature* 387:569-72.
- Smit, L., de Vries-Smits, A. M., Bos, J. L., Borst, J. (1994). B cell antigen receptor stimulation induces formation of a Shc-Grb2 complex containing multiple tyrosine-phosphorylated proteins. *J Biol Chem* 269:20209-12.
- Smith, K. G., Hewitson, T. D., Nossal, G. J., Tarlinton, D. M. (1996). The phenotype and fate of the antibody-forming cells of the splenic foci. *Eur J Immunol* 26:444-8.
- Smith, K. G., Tarlinton, D. M., Doody, G. M., Hibbs, M. L., Fearon, D. T. (1998). Inhibition of the B cell by CD22: a requirement for Lyn. *J Exp Med* 187:807-11.
- Somani, A. K., Yuen, K., Xu, F., Zhang, J., Branch, D. R., Siminovitch, K. A. (2001). The SH2 domain containing tyrosine phosphatase-1 down-regulates activation of Lyn and Lyn-induced tyrosine phosphorylation of the CD19 receptor in B cells. *J Biol Chem* 276:1938-44.
- Songyang, Z., Cantley, L. C. (1995). Recognition and specificity in protein tyrosine kinase-mediated signalling. *Trends Biochem Sci* 20:470-5.
- Stanley, E., Ralph, S., McEwen, S., Boulet, I., Holtzman, D. A., Lock, P., Dunn, A. R. (1991). Alternatively spliced murine lyn mRNAs encode distinct proteins. *Mol Cell Biol* 11:3399-406.

- Stauffer, T. P., Meyer, T. (1997). Compartmentalized IgE receptor-mediated signal transduction in living cells. *J Cell Biol* 139:1447-54.
- Stephens, L., Smrcka, A., Cooke, F. T., Jackson, T. R., Sternweis, P. C., Hawkins, P. T. (1994). A novel phosphoinositide 3 kinase activity in myeloid-derived cells is activated by G protein beta gamma subunits. *Cell* 77:83-93.
- Stephens, L. R., Eguinoa, A., Erdjument-Bromage, H., Lui, M., Cooke, F., Coadwell, J., Smrcka, A. S., Thelen, M., Cadwallader, K., Tempst, P., Hawkins, P. T. (1997). The G beta gamma sensitivity of a PI3K is dependent upon a tightly associated adaptor, p101. *Cell* 89:105-14.
- Stephens, L. R., Jackson, T. R., Hawkins, P. T. (1993). Agonist-stimulated synthesis of phosphatidylinositol(3,4,5)-trisphosphate: a new intracellular signalling system? *Biochim Biophys Acta* 1179:27-75.
- Stokoe, D., Macdonald, S. G., Cadwallader, K., Symons, M., Hancock, J. F. (1994). Activation of Raf as a result of recruitment to the plasma membrane. *Science* 264:1463-7.
- Stoyanov, B., Volinia, S., Hanck, T., Rubio, I., Loubtchenkov, M., Malek, D., Stoyanova, S., Vanhaesebroeck, B., Dhand, R., Nurnberg, B., et al. (1995). Cloning and characterization of a G protein-activated human phosphoinositide-3 kinase. *Science* 269:690-3.
- Stoyanova, S., Bulgarelli-Leva, G., Kirsch, C., Hanck, T., Klinger, R., Wetzker, R., Wymann, M. P. (1997). Lipid kinase and protein kinase activities of G-protein-coupled phosphoinositide 3-kinase gamma: structure-activity analysis and interactions with wortmannin. *Biochem J* 324:489-95.
- Sturani, E., Vicentini, L. M., Zippel, R., Toschi, L., Pandiella-Alonso, A., Comoglio, P. M., Meldolesi, J. (1986). PDGF-induced receptor phosphorylation and phosphoinositide hydrolysis are unaffected by protein kinase C activation in mouse Swiss 3T3 and human skin fibroblasts. *Biochem Biophys Res Commun* 137:343-50.
- Su, Y. W., Zhang, Y., Schweikert, J., Koretzky, G. A., Reth, M., Wienands, J. (1999). Interaction of SLP adaptors with the SH2 domain of Tec family kinases. *Eur J Immunol* 29:3702-11.
- Sudol, M., Greulich, H., Newman, L., Sarkar, A., Sukegawa, J., Yamamoto, T. (1993). A novel Yes-related kinase, Yrk, is expressed at elevated levels in neural and hematopoietic tissues. *Oncogene* 8:823-31.
- Sutherland, C. L., Heath, A. W., Pelech, S. L., Young, P. R., Gold, M. R. (1996). Differential activation of the ERK, JNK, and p38 mitogen-activated protein kinases by CD40 and the B cell antigen receptor. *J Immunol* 157:3381-90.
- Suzu, S., Tanaka-Douzono, M., Nomaguchi, K., Yamada, M., Hayasawa, H., Kimura, F., Motoyoshi, K. (2000). p56(dok-2) as a cytokine-inducible inhibitor of cell proliferation and signal transduction. *Embo J* 19:5114-22.
- Suzuki, H., Terauchi, Y., Fujiwara, M., Aizawa, S., Yazaki, Y., Kadowaki, T., Koyasu, S. (1999). Xid-like immunodeficiency in mice with disruption of the p85alpha subunit of phosphoinositide 3-kinase. *Science* 283:390-2.
- Symington, F. W., Subbarao, B., Mosier, D. E., Sprent, J. (1982). Lyb-8.2: A new B cell antigen defined and characterized with a monoclonal antibody. *Immunogenetics* 16:381-91.
- Takai, T., Ono, M., Hikida, M., Ohmori, H., Ravetch, J. V. (1996). Augmented humoral and anaphylactic responses in Fc gamma RII-deficient mice. *Nature* 379:346-9.
- Takata, M., Homma, Y., Kurosaki, T. (1995). Requirement of phospholipase C-gamma 2 activation in surface immunoglobulin M-induced B cell apoptosis. *J Exp Med* 182:907-14.

- Takata, M., Kurosaki, T. (1996). A role for Bruton's tyrosine kinase in B cell antigen receptor-mediated activation of phospholipase C-gamma 2. *J Exp Med* 184:31-40.
- Takata, M., Sabe, H., Hata, A., Inazu, T., Homma, Y., Nukada, T., Yamamura, H., Kurosaki, T. (1994). Tyrosine kinases Lyn and Syk regulate B cell receptor-coupled Ca²⁺ mobilization through distinct pathways. *Embo J* 13:1341-9.
- Takeuchi, S., Takayama, Y., Ogawa, A., Tamura, K., Okada, M. (2000). Transmembrane phosphoprotein Cbp positively regulates the activity of the carboxyl-terminal Src kinase, Csk. *J Biol Chem* 275:29183-6.
- Tamir, I., Cambier, J. C. (1998). Antigen receptor signaling: integration of protein tyrosine kinase functions. *Oncogene* 17:1353-64.
- Tamir, I., Stolpa, J. C., Helgason, C. D., Nakamura, K., Bruhns, P., Daeron, M., Cambier, J. C. (2000). The RasGAP-binding protein p62dok is a mediator of inhibitory FcgammaRIIB signals in B cells. *Immunity* 12:347-58.
- Tanaka, N., Asao, H., Ohtani, K., Nakamura, M., Sugamura, K. (1993). A novel human tyrosine kinase gene inducible in T cells by interleukin 2. *FEBS Lett* 324:1-5.
- Taniguchi, T., Kitagawa, H., Yasue, S., Yanagi, S., Sakai, K., Asahi, M., Ohta, S., Takeuchi, F., Nakamura, S., Yamamura, H. (1993). Protein-tyrosine kinase p72syk is activated by thrombin and is negatively regulated through Ca²⁺ mobilization in platelets. *J Biol Chem* 268:2277-9.
- Taniguchi, T., Kobayashi, T., Kondo, J., Takahashi, K., Nakamura, H., Suzuki, J., Nagai, K., Yamada, T., Nakamura, S., Yamamura, H. (1991). Molecular cloning of a porcine gene syk that encodes a 72-kDa protein-tyrosine kinase showing high susceptibility to proteolysis. *J Biol Chem* 266:15790-6.
- Tedder, T. F., Sato, S., Poe, J. C., Fujimoto, M. (1999). CD19 and CD22 regulate a B lymphocyte signal transduction pathway that contributes to autoimmunity.
- Tedder, T. F., Inaoki, M., Sato, S. (1997). The CD19-CD21 complex regulates signal transduction thresholds governing humoral immunity and autoimmunity. *Immunity* 6:107-18.
- Tedder, T. F., Isaacs, C. M. (1989). Isolation of cDNAs encoding the CD19 antigen of human and mouse B lymphocytes. A new member of the immunoglobulin superfamily. *J Immunol* 143:712-7.
- Tedder, T. F., Sato, S., Poe, J. C., Fujimoto, M. (2000). CD19 and CD22 regulate a B lymphocyte signal transduction pathway that contributes to autoimmunity. *Keio J Med* 49:1-13.
- Tedder, T. F., Zhou, L. J., Engel, P. (1994). The CD19/CD21 signal transduction complex of B lymphocytes. *Immunol Today* 15:437-42.
- Terauchi, Y., Tsuji, Y., Satoh, S., Minoura, H., Murakami, K., Okuno, A., Inukai, K., Asano, T., Kaburagi, Y., Ueki, K., Nakajima, H., Hanafusa, T., Matsuzawa, Y., Sekihara, H., Yin, Y., Barrett, J. C., Oda, H., Ishikawa, T., Akanuma, Y., Komuro, I., Suzuki, M., Yamamura, K., Kodama, T., Suzuki, H., Kadowaki, T., et al. (1999). Increased insulin sensitivity and hypoglycaemia in mice lacking the p85 alpha subunit of phosphoinositide 3-kinase. *Nat Genet* 21:230-5.
- Tezuka, T., Umemori, H., Fusaki, N., Yagi, T., Takata, M., Kurosaki, T., Yamamoto, T. (1996). Physical and functional association of the cbl protooncogene product with an src-family protein tyrosine kinase, p53/56lyn, in the B cell antigen receptor-mediated signaling. *J Exp Med* 183:675-80.
- Timmerman, L. A., Clipstone, N. A., Ho, S. N., Northrop, J. P., Crabtree, G. R. (1996). Rapid shuttling of NF-AT in discrimination of Ca²⁺ signals and immunosuppression. *Nature* 383:837-40.
- Toker, A., Cantley, L. C. (1997). Signalling through the lipid products of phosphoinositide-3-OH kinase. *Nature* 387:673-6.

- Tooze, R. M., Doody, G. M., Fearon, D. T. (1997). Counterregulation by the coreceptors CD19 and CD22 of MAP kinase activation by membrane immunoglobulin. *Immunity* 7:59-67.
- Tordai, A., Franklin, R. A., Patel, H., Gardner, A. M., Johnson, G. L., Gelfand, E. W. (1994). Cross-linking of surface IgM stimulates the Ras/Raf-1/MEK/MAPK cascade in human B lymphocytes. *J Biol Chem* 269:7538-43.
- Torres, R. M., Flaswinkel, H., Reth, M., Rajewsky, K. (1996). Aberrant B Cell Development and Immune Response in Mice with a Compromised BCR Complex. *Science* 272:1802-4.
- Treisman, R. (1994). Ternary complex factors: growth factor regulated transcriptional activators. *Curr Opin Genet Dev* 4:96-101.
- Treisman, R. (1996). Regulation of transcription by MAP kinase cascades. *Curr Opin Cell Biol* 8:205-15.
- Tridandapani, S., Chacko, G. W., Van Brocklyn, J. R., Coggeshall, K. M. (1997). Negative signaling in B cells causes reduced Ras activity by reducing Shc-Grb2 interactions. *J Immunol* 158:1125-32.
- Tseng, J., Eisfelder, B. J., Clark, M. R. (1997). B-cell antigen receptor-induced apoptosis requires both Ig alpha and Ig beta. *Blood* 89:1513-20.
- Tsukada, S., Saffran, D. C., Rawlings, D. J., Parolini, O., Allen, R. C., Klisak, I., Sparkes, R. S., Kubagawa, H., Mohandas, T., Quan, S., et al. (1993). Deficient expression of a B cell cytoplasmic tyrosine kinase in human X-linked agammaglobulinemia. *Cell* 72:279-90.
- Tsygankov, A. Y., Teckchandani, A. M., Feshchenko, E. A., Swaminathan, G. (2001). Beyond the RING: CBL proteins as multivalent adapters. *Oncogene* 20:6382-402.
- Turner, J. M., Brodsky, M. H., Irving, B. A., Levin, S. D., Perlmutter, R. M., Littman, D. R. (1990). Interaction of the unique N-terminal region of tyrosine kinase p56lck with cytoplasmic domains of CD4 and CD8 is mediated by cysteine motifs. *Cell* 60:755-65.
- Turner, M., Mee, P. J., Costello, P. S., Williams, O., Price, A. A., Duddy, L. P., Furlong, M. T., Geahlen, R. L., Tybulewicz, V. L. (1995). Perinatal lethality and blocked B-cell development in mice lacking the tyrosine kinase Syk. *Nature* 378:298-302.
- Tuscano, J., Engel, P., Tedder, T. F., Kehrl, J. H. (1996). Engagement of the adhesion receptor CD22 triggers a potent stimulatory signal for B cells and blocking CD22/CD22L interactions impairs T-cell proliferation. *Blood* 87:4723-30.
- Tuscano, J. M., Engel, P., Tedder, T. F., Agarwal, A., Kehrl, J. H. (1996). Involvement of p72syk kinase, p53/56lyn kinase and phosphatidylinositol-3 kinase in signal transduction via the human B lymphocyte antigen CD22. *Eur J Immunol* 26:1246-52.
- Tuveson, D. A., Carter, R. H., Soltoff, S. P., Fearon, D. T. (1993). CD19 of B cells as a surrogate kinase insert region to bind phosphatidylinositol 3-kinase. *Science* 260:986-9.
- Tybulewicz, V. L. (1998). Analysis of antigen receptor signalling using mouse gene targeting. *Curr Opin Cell Biol* 10:195-204.
- Uckun, F. M., Waddick, K. G., Mahajan, S., Jun, X., Takata, M., Bolen, J., Kurosaki, T. (1996). BTK as a mediator of radiation-induced apoptosis in DT-40 lymphoma B cells. *Science* 273:1096-100.
- Ujike, A., Takeda, K., Nakamura, A., Ebihara, S., Akiyama, K., Takai, T. (2002). Impaired dendritic cell maturation and increased T(H)2 responses in PIR- B(-/-) mice. *Nat Immunol* 3:542-8.
- Umemori, H., Wanaka, A., Kato, H., Takeuchi, M., Tohyama, M., Yamamoto, T. (1992). Specific expressions of Fyn and Lyn, lymphocyte antigen receptor-associated tyrosine kinases, in the central nervous system. *Brain Res Mol Brain Res* 16:303-10.

- Unkeless, J. C. (1979). Characterization of a monoclonal antibody directed against mouse macrophage and lymphocyte Fc receptors. *J Exp Med* 150:580-96.
- Van Noesel, C. J., Brouns, G. S., van Schijndel, G. M., Bende, R. J., Mason, D. Y., Borst, J., van Lier, R. A. (1992). Comparison of human B cell antigen receptor complexes: membrane-expressed forms of immunoglobulin (Ig)M, IgD, and IgG are associated with structurally related heterodimers. *J Exp Med* 175:1511-9.
- van Noesel, C. J., Lankester, A. C., van Schijndel, G. M., van Lier, R. A. (1993). The CR2/CD19 complex on human B cells contains the src-family kinase Lyn. *Int Immunol* 5:699-705.
- Vanhaesebroeck, B., Leeyers, S. J., Panayotou, G., Waterfield, M. D. (1997). Phosphoinositide 3-kinases: a conserved family of signal transducers. *Trends Biochem Sci* 22:267-72.
- Vanhaesebroeck, B., Welham, M. J., Kotani, K., Stein, R., Warne, P. H., Zvelebil, M. J., Higashi, K., Volinia, S., Downward, J., Waterfield, M. D. (1997). P110delta, a novel phosphoinositide 3-kinase in leukocytes. *Proc Natl Acad Sci U S A* 94:4330-5.
- Varnai, P., Rother, K. I., Balla, T. (1999). Phosphatidylinositol 3-kinase-dependent membrane association of the Bruton's tyrosine kinase pleckstrin homology domain visualized in single living cells. *J Biol Chem* 274:10983-9.
- Veillette, A., Latour, S., Davidson, D. (2002). Negative regulation of immunoreceptor signaling. *Annu Rev Immunol* 20:669-707.
- Venkataraman, C., Lu, P. J., Buhl, A. M., Chen, C. S., Cambier, J. C., Bondada, S. (1998). CD72-mediated B cell activation involves recruitment of CD19 and activation of phosphatidylinositol 3-kinase. *Eur J Immunol* 28:3003-16.
- Venkataraman, C., Muthusamy, N., Muthukkumar, S., Bondada, S. (1998). Activation of lyn, blk, and btk but not syk in CD72-stimulated B lymphocytes. *J Immunol* 160:3322-9.
- Venkataraman, L., Francis, D. A., Wang, Z., Liu, J., Rothstein, T. L., Sen, R. (1994). Cyclosporin-A sensitive induction of NF-AT in murine B cells. *Immunity* 1:189-96.
- Venkitaraman, A. R., Williams, G. T., Dariavach, P., Neuberger, M. S. (1991). The B-cell antigen receptor of the five immunoglobulin classes. *Nature* 352:777-81.
- Vetrie, D., Vorechovsky, I., Sideras, P., Holland, J., Davies, A., Flinter, F., Hammarstrom, L., Kinnon, C., Levinsky, R., Bobrow, M., et al. (1993). The gene involved in X-linked agammaglobulinaemia is a member of the src family of protein-tyrosine kinases. *Nature* 361:226-33.
- Vihinen, M., Nilsson, L., Smith, C. I. (1994). Tec homology (TH) adjacent to the PH domain. *FEBS Lett* 350:263-5.
- Vlahos, C. J., Matter, W. F., Hui, K. Y., Brown, R. F. (1994). A specific inhibitor of phosphatidylinositol 3-kinase, 2-(4-morpholinyl)-8-phenyl-4H-1-benzopyran-4-one (LY294002). *J Biol Chem* 269:5241-8.
- Von Hoegen, I., Nakayama, E., Parnes, J. R. (1990). Identification of a human protein homologous to the mouse Lyb-2 B cell differentiation antigen and sequence of the corresponding cDNA. *J Immunol* 144:4870-7.
- Von Willebrand, M., Jascur, T., Bonnefoy-Berard, N., Yano, H., Altman, A., Matsuda, Y., Mustelin, T. (1996). Inhibition of phosphatidylinositol 3-kinase blocks T cell antigen receptor/CD3-induced activation of the mitogen-activated kinase Erk2. *Eur J Biochem* 235:828-35.
- Wakabayashi, C., Adachi, T., Wienands, J., Tsubata, T. (2002). A distinct signaling pathway used by the IgG-containing B cell antigen receptor. *Science* 298:2392-5.

- Walaas, S. I., Zhao, Y. H., Sudol, M. (1993). Neuronal localization of the tyrosine-specific protein kinase p62c-yes in rat basal ganglia. *Neurochem Res* 18:43-6.
- Wang, D.
- Wang, J., Koizumi, T., Watanabe, T. (1996). Altered antigen receptor signaling and impaired Fas-mediated apoptosis of B cells in Lyn-deficient mice. *J Exp Med* 184:831-8.
- Wang, Y., Brooks, S. R., Li, X., Anzelon, A. N., Rickert, R. C., Carter, R. H. (2002). The physiologic role of CD19 cytoplasmic tyrosines. *Immunity* 17:501-14.
- Wechsler, R. J., Monroe, J. G. (1995). src-family tyrosine kinase p55fgr is expressed in murine splenic B cells and is activated in response to antigen receptor cross-linking. *J Immunol* 154:3234-44.
- Welch, H., Eguinoa, A., Stephens, L. R., Hawkins, P. T. (1998). Protein kinase B and rac are activated in parallel within a phosphatidylinositide 3OH-kinase-controlled signaling pathway. *J Biol Chem* 273:11248-56.
- Weng, W. K., Jarvis, L., LeBien, T. W. (1994). Signaling through CD19 activates Vav/mitogen-activated protein kinase pathway and induces formation of a CD19/Vav/phosphatidylinositol 3-kinase complex in human B cell precursors. *J Biol Chem* 269:32514-21.
- Wennstrom, S., Downward, J. (1999). Role of phosphoinositide 3-kinase in activation of ras and mitogen-activated protein kinase by epidermal growth factor. *Mol Cell Biol* 19:4279-88.
- White, E. (1996). Life, death, and the pursuit of apoptosis. *Genes Dev* 10:1-15.
- Whitman, M., Downes, C. P., Keeler, M., Keller, T., Cantley, L. (1988). Type I phosphatidylinositol kinase makes a novel inositol phospholipid, phosphatidylinositol-3-phosphate. *Nature* 332:644-6.
- Wienands, J., Reth, M. (1991). The B cell antigen receptor of class IgD can be expressed on the cell surface in two different forms. *Eur J Immunol* 21:2373-8.
- Wienands, J., Schweikert, J., Wollscheid, B., Jumaa, H., Nielsen, P. J., Reth, M. (1998). SLP-65: a new signaling component in B lymphocytes which requires expression of the antigen receptor for phosphorylation. *J Exp Med* 188:791-5.
- Woods, D., Parry, D., Cherwinski, H., Bosch, E., Lees, E., McMahon, M. (1997). Raf-induced proliferation or cell cycle arrest is determined by the level of Raf activity with arrest mediated by p21Cip1. *Mol Cell Biol* 17:5598-611.
- Woscholski, R., Parker, P. J. (1997). Inositol lipid 5-phosphatases--traffic signals and signal traffic. *Trends Biochem Sci* 22:427-31.
- Wu, Y., Nadler, M. J., Brennan, L. A., Gish, G. D., Timms, J. F., Fusaki, N., Jongstra-Bilen, J., Tada, N., Pawson, T., Wither, J., Neel, B. G., Hozumi, N. (1998). The B-cell transmembrane protein CD72 binds to and is an in vivo substrate of the protein tyrosine phosphatase SHP-1. *Curr Biol* 8:1009-17.
- Wu, Y., Pani, G., Siminovitch, K., Hozumi, N. (1995). Antigen receptor-triggered apoptosis in immature B cell lines is associated with the binding of a 44-kDa phosphoprotein to the PTP1C tyrosine phosphatase. *Eur J Immunol* 25:2279-84.
- Wymann, M. P., Pirola, L. (1998). Structure and function of phosphoinositide 3-kinases. *Biochim Biophys Acta* 1436:127-50.
- Xie, H., Rothstein, T. L. (1995). Protein kinase C mediates activation of nuclear cAMP response element-binding protein (CREB) in B lymphocytes stimulated through surface Ig. *J Immunol* 154:1717-23.

- Xie, H., Wang, Z., Rothstein, T. L. (1996). Signaling pathways for antigen receptor-mediated induction of transcription factor CREB in B lymphocytes. *Cell Immunol* 169:264-70.
- Xu, W., Harrison, S. C., Eck, M. J. (1997). Three-dimensional structure of the tyrosine kinase c-Src. *Nature* 385:595-602.
- Xu, Y., Beavitt, S. J., Harder, K. W., Hibbs, M. L., Tarlinton, D. M. (2002). The activation and subsequent regulatory roles of Lyn and CD19 after B cell receptor ligation are independent. *J Immunol* 169:6910-8.
- Yamanashi, Y., Fukuda, T., Nishizumi, H., Inazu, T., Higashi, K., Kitamura, D., Ishida, T., Yamamura, H., Watanabe, T., Yamamoto, T. (1997). Role of tyrosine phosphorylation of HS1 in B cell antigen receptor-mediated apoptosis. *J Exp Med* 185:1387-92.
- Yamanashi, Y., Fukui, Y., Wongsasant, B., Kinoshita, Y., Ichimori, Y., Toyoshima, K., Yamamoto, T. (1992). Activation of Src-like protein-tyrosine kinase Lyn and its association with phosphatidylinositol 3-kinase upon B-cell antigen receptor-mediated signaling. *Proc Natl Acad Sci U S A* 89:1118-22.
- Yamanashi, Y., Kakiuchi, T., Mizuguchi, J., Yamamoto, T., Toyoshima, K. (1991). Association of B cell antigen receptor with protein tyrosine kinase Lyn. *Science* 251:192-4.
- Yamanashi, Y., Mori, S., Yoshida, M., Kishimoto, T., Inoue, K., Yamamoto, T., Toyoshima, K. (1989). Selective expression of a protein-tyrosine kinase, p56lyn, in hematopoietic cells and association with production of human T-cell lymphotropic virus type I. *Proc Natl Acad Sci U S A* 86:6538-42.
- Yamanashi, Y., Okada, M., Semba, T., Yamori, T., Umemori, H., Tsunasawa, S., Toyoshima, K., Kitamura, D., Watanabe, T., Yamamoto, T. (1993). Identification of HS1 protein as a major substrate of protein-tyrosine kinase(s) upon B-cell antigen receptor-mediated signaling. *Proc Natl Acad Sci U S A* 90:3631-5.
- Yamanashi, Y., Tamura, T., Kanamori, T., Yamane, H., Nariuchi, H., Yamamoto, T., Baltimore, D. (2000). Role of the rasGAP-associated docking protein p62(dok) in negative regulation of B cell receptor-mediated signaling. *Genes Dev* 14:11-6.
- Yamashita, Y., Fukuta, D., Tsuji, A., Nagabukuro, A., Matsuda, Y., Nishikawa, Y., Ohyama, Y., Ohmori, H., Ono, M., Takai, T. (1998). Genomic structures and chromosomal location of p91, a novel murine regulatory receptor family. *J Biochem (Tokyo)* 123:358-68.
- Yamazaki, T., Kurosaki, T. (2003). Contribution of BCAP to maintenance of mature B cells through c-Rel. *Nat Immunol* 4:780-6.
- Yamazaki, T., Takeda, K., Gotoh, K., Takeshima, H., Akira, S., Kurosaki, T. (2002). Essential immunoregulatory role for BCAP in B cell development and function. *J Exp Med* 195:535-45.
- Yanagi, S., Sugawara, H., Kurosaki, M., Sabe, H., Yamamura, H., Kurosaki, T. (1996). CD45 modulates phosphorylation of both autophosphorylation and negative regulatory tyrosines of Lyn in B cells. *J Biol Chem* 271:30487-92.
- Yang, C., Maruyama, S., Yanagi, S., Wang, X., Takata, M., Kurosaki, T., Yamamura, H. (1995). Syk and Lyn are involved in radiation-induced signaling, but inactivation of Syk or Lyn alone is not sufficient to prevent radiation-induced apoptosis. *J Biochem (Tokyo)* 118:33-8.
- Yang, E., Zha, J., Jockel, J., Boise, L. H., Thompson, C. B., Korsmeyer, S. J. (1995). Bad, a heterodimeric partner for Bcl-XL and Bcl-2, displaces Bax and promotes cell death. *Cell* 80:285-91.
- Yankee, T. M., Keshvara, L. M., Sawadikosol, S., Harrison, M. L., Geahlen, R. L. (1999). Inhibition of signaling through the B cell antigen receptor by the protooncogene product, c-Cbl, requires Syk tyrosine 317 and the c-Cbl phosphotyrosine-binding domain. *J Immunol* 163:5827-35.
- Yao, L., Kawakami, Y., Kawakami, T. (1994). The pleckstrin homology domain of Bruton tyrosine

- kinase interacts with protein kinase C. *Proc Natl Acad Sci U S A* 91:9175-9.
- Yi, T. L., Bolen, J. B., Ihle, J. N. (1991). Hematopoietic cells express two forms of lyn kinase differing by 21 amino acids in the amino terminus. *Mol Cell Biol* 11:2391-8.
- Yokouchi, M., Kondo, T., Sanjay, A., Houghton, A., Yoshimura, A., Komiya, S., Zhang, H., Baron, R. (2001). Src-catalyzed phosphorylation of c-Cbl leads to the interdependent ubiquitination of both proteins. *J Biol Chem* 276:35185-93.
- Yokozeki, T., Adler, K., Lankar, D., Bonnerot, C. (2003). B cell receptor-mediated Syk-independent activation of phosphatidylinositol 3-kinase, Ras, and mitogen-activated protein kinase pathways. *J Immunol* 171:1328-35.
- Yu, J. Z., Y., McIlroy, J. Orr, G.A, Backer, J. M. (1998). Regulation of the p85/p110 phosphatidylinositol 3'-kinase: stabilization and inhibition of the p110a catalytic subunit by the p85 regulatory subunit. *Mol Cell Biol* 18:1379-1387.
- Zha, J., Harada, H., Yang, E., Jockel, J., Korsmeyer, S. J. (1996). Serine phosphorylation of death agonist BAD in response to survival factor results in binding to 14-3-3 not BCL-X(L). *Cell* 87:619-28.
- Zhang, Y., Wienands, J., Zurn, C., Reth, M. (1998). Induction of the antigen receptor expression on B lymphocytes results in rapid competence for signaling of SLP-65 and Syk. *Embo J* 17:7304-10.
- Zhou, L. J., Ord, D. C., Hughes, A. L., Tedder, T. F. (1991). Structure and domain organization of the CD19 antigen of human, mouse, and guinea pig B lymphocytes. Conservation of the extensive cytoplasmic domain. *J Immunol* 147:1424-32.
- Zhou, L. J., Smith, H. M., Waldschmidt, T. J., Schwarting, R., Daley, J., Tedder, T. F. (1994). Tissue-specific expression of the human CD19 gene in transgenic mice inhibits antigen-independent B-lymphocyte development. *Mol Cell Biol* 14:3884-94.
- Zioncheck, T. F., Harrison, M. L., Geahlen, R. L. (1986). Purification and characterization of a protein-tyrosine kinase from bovine thymus. *J Biol Chem* 261:15637-43.



Minerva Access is the Institutional Repository of The University of Melbourne

Author/s:

XU, YUEKANG

Title:

Biochemical basis of B cell dysfunction in Lyn kinase deficient mice

Date:

2003-11

Citation:

Xu, Y. (2003). Biochemical basis of B cell dysfunction in Lyn kinase deficient mice. PhD thesis, The Walter and Eliza Hall Institute of Medical Research, and, Department of Medical Biology, The University of Melbourne.

Publication Status:

Unpublished

Persistent Link:

<http://hdl.handle.net/11343/39187>

File Description:

Biochemical basis of B cell dysfunction in Lyn kinase deficient mice

Terms and Conditions:

Terms and Conditions: Copyright in works deposited in Minerva Access is retained by the copyright owner. The work may not be altered without permission from the copyright owner. Readers may only download, print and save electronic copies of whole works for their own personal non-commercial use. Any use that exceeds these limits requires permission from the copyright owner. Attribution is essential when quoting or paraphrasing from these works.