



Durham E-Theses

The differential expression of the genes encoding glutamine synthetase in developing root modules

Teverson, Rachel

How to cite:

Teverson, Rachel (1990) *The differential expression of the genes encoding glutamine synthetase in developing root modules*, Durham theses, Durham University. Available at Durham E-Theses Online: <http://etheses.dur.ac.uk/5958/>

Use policy

The full-text may be used and/or reproduced, and given to third parties in any format or medium, without prior permission or charge, for personal research or study, educational, or not-for-profit purposes provided that:

- a full bibliographic reference is made to the original source
- a [link](#) is made to the metadata record in Durham E-Theses
- the full-text is not changed in any way

The full-text must not be sold in any format or medium without the formal permission of the copyright holders.

Please consult the [full Durham E-Theses policy](#) for further details.

Academic Support Office, Durham University, University Office, Old Elvet, Durham DH1 3HP
e-mail: e-theses.admin@dur.ac.uk Tel: +44 0191 334 6107
<http://etheses.dur.ac.uk>

THE DIFFERENTIAL EXPRESSION OF THE GENES ENCODING GLUTAMINE SYNTHETASE

IN DEVELOPING ROOT NODULES

by

Rachel Teverson BSc. (hons).

A thesis submitted in accordance with the requirements for the degree
of Doctor of Philosophy of the University of Durham.

Department of Biological Sciences, University of Durham.

Collaborating establishment; Department of Biochemistry and Crop
Physiology, Institute of Arable Crops Research, Harpenden, Herts.

January 1990



17 007 287

To my Mother
and in memory of my Father.

CONTENTS

	page
1. <u>INTRODUCTION</u>	1
1.1. PROSPECTS FOR THE IMPROVEMENT OF NITROGEN FIXATION	1
1.2. THE CLASSIFICATION, DEVELOPMENT AND STRUCTURE OF ROOT NODULES	5
1.2.1. Root Nodule Classification	5
1.2.2. Early Root Nodule Development	7
1.2.2.1. Attraction	
1.2.2.2. Root Hair Invasion and Growth of the Infection Thread	
1.2.2.3. Release of the <i>Rhizobium</i> and Host Plant Infection	
1.2.3. Root Nodule Structure	12
1.2.3.1. General Structure	
1.2.3.2. The Root Nodule Vascular System	
1.2.3.3. Structure of Elongate/Indeterminate Nodules	
1.2.3.4. Structure of Spherical Nodules	
1.3. THE BIOCHEMISTRY OF ROOT NODULES	18
1.3.1. Energy Requirements For Nitrogen Fixation	18
1.3.2. The Nitrogenase Enzyme	19
1.3.3. Uptake Hydrogenase	20
1.3.4. Oxygen Metabolism	21
1.3.5. Leghaemoglobin	21
1.3.6. The Assimilation of Ammonia in the Host Plant Cells	23
1.4. GLUTAMINE SYNTHETASE	28
1.4.1. The Genes Encoding Glutamine Synthetase	28
1.4.2. Glutamine Synthetase Expression in Developing Nodules	29
1.4.3. Assembly of GS Polypeptides in <i>P. vulgaris</i> Root Nodules	29
1.4.4. The Regulation of GS Gene Expression in <i>P. vulgaris</i> Root Nodules	30
1.4.5. The Expression of Chimaeric GS Genes in Transgenic Plants	31
1.4.6. The Expression of GS in Root Nodules of Other Legume Species	31

2.3.3.2.	Hybridization	
2.3.3.3.	Post Hybridization Washes	
2.3.3.4.	Probe Detection	
2.3.3.5.	<i>L. corniculatus</i> Hybridizations	
2.4.	IMMUNO LABELLING AND STAINING FOR β -GLUCURONIDASE	66
2.4.1.	Immuno-Labelling of PEG Embedded Sections for Light Microscopy	66
2.4.1.1.	Immuno-Gold Labelling of Sections for Light Microscopy	
2.4.1.2.	Alkaline Phosphatase Protein Localization	
2.4.2.	Immuno-Gold Labelling of Resin Embedded Sections for Electron Microscopy	
2.4.3.	β -Glucuronidase (GUS) Localization in Transformed <i>L. corniculatus</i> Plants	

RESULTS AND DISCUSSION

3.	<u>THE STRUCTURE AND DEVELOPMENT OF <i>P. vulgaris</i> ROOT NODULES</u>	69
3.1.	STAGES OF NODULE DEVELOPMENT	69
3.1.1.	Early Stage Nodules	69
3.1.2.	Intermediate Stage Nodules	72
3.1.3.	Late Stage Nodules	75
4.	<u>THE APPLICATION OF <i>In situ</i> HISTOCHEMICAL TECHNIQUES</u>	77
4.1.	TISSUE PREPARATION	78
4.1.1.	Fixing of Tissue	78
4.1.2.	Embedding of Tissue	82
4.2.	<i>In situ</i> HYBRIDIZATION TO CYTOSOLIC mRNAs	85
4.2.1.	Preparation and Labelling of Probes	85
4.2.2.	Hybridization Pretreatments	89
4.2.3.	Hybridization Conditions	91
4.2.4.	Post-Hybridization Washes	92
4.2.5.	Methods of Probe Detection	92
4.3.	IMMUNOCYTOCHEMISTRY FOR PROTEIN LOCALIZATION	97

	page
5. THE USE OF <i>In situ</i> HISTOCHEMICAL TECHNIQUES TO LOCALIZE GS mRNA <u>AND PROTEIN IN <i>P. vulgaris</i> ROOT NODULES</u>	97
5.1. RESULTS	97
5.1.1. The Localization of GS mRNA	97
5.1.2. The Immunocytochemical Localization of GS Protein	100
5.1.2.1. Immuno-Gold Localization of GS Protein	
5.1.2.2. Alkaline Phosphatase Visualization of GS Protein	
5.1.3. Summary of Results on the Localization of GS mRNA and Protein	102
5.2. DISCUSSION	105
5.2.1. The Location of GS in <i>P. vulgaris</i> Root Nodules	105
5.2.2. The Temporal Pattern of GS Expression in <i>P. vulgaris</i> Root Nodules	105
5.2.3. The Assembly of the GS Polypeptides in <i>P. vulgaris</i>	111
5.2.4. Implications for the Spatial and Temporal Expression of GS in <i>P. vulgaris</i> Root Nodules	112
6. THE EXPRESSION OF GS/GUS GENE FUSIONS IN NODULES OF TRANSGENIC <i>L.</i> <u><i>corniculatus</i> PLANTS</u>	116
6.1. <i>In situ</i> HISTOCHEMICAL RESULTS	116
6.1.1. The Expression of the β /GUS Construct	117
6.1.2. Expression of the γ /GUS Construct	118
6.2. DISCUSSION	123
6.2.1. The Expression of GS/GUS Gene Fusions in <i>L. corniculatus</i> Plants	123
6.2.2. Comparison of the GS Expression in Chimaeric <i>L.</i> <i>corniculatus</i> and <i>P. vulgaris</i> Plants	125
6.2.3. The Influence of the 5' Flanking Regions on GS gene Expression	127
7. DISCUSSION: THE EXPRESSION OF GS IN LEGUME ROOT NODULES	129
7.1. THE CONTROL OF GENE EXPRESSION IN OTHER NODULE SYSTEMS	129
7.2. THE CONTROL OF GS GENE EXPRESSION IN <i>P. vulgaris</i>	131
7.2.1. The Influence of Gene Structure on the Expression of GS	132

	page
7.2.2. Factors Involved in the Induction of GS Genes in Root Nodules	134
7.2.3. The Temporal and Spatial Control of GS Isoenzyme Assembly	137
7.3. FUTURE WORK	140
7.3.1. Further Use of <i>In situ</i> Hybridization Techniques	140
7.3.2. Further Investigations into Gene Expression in Legume Root Nodules	140
8. <u>SUMMARY</u>	142
9. <u>REFERENCES</u>	

ABSTRACT.

THE DIFFERENTIAL EXPRESSION OF GENES ENCODING GLUTAMINE SYNTHETASE IN

DEVELOPING ROOT NODULES

by
Rachel Teverson.

Glutamine synthetase (GS) is one of the key enzymes involved in the assimilation of ammonia into organic nitrogen in plants. It is important in legume root nodules where ammonia, produced by the *Rhizobium*-legume symbiosis, is converted to organic nitrogen before it can be transported to other parts of the plant.

In *Phaseolus vulgaris* three cytosolic and one plastidic GS polypeptide have been identified. One or more of these polypeptides assemble to form distinct octameric GS isoenzymes.

GS activity increases significantly in *P. vulgaris* during nodulation and this is associated with the increased (or repressed) expression of the three cytosolic polypeptide genes *gln- α* , *gln- β* and *gln- γ* .

The temporal and spatial pattern of mRNA and protein distribution of these genes has been investigated using *in situ* hybridization and immunocytochemistry.

An *in situ* hybridization protocol has been established using photobiotinylated cRNA probes, visualised with alkaline phosphatase, or streptavidin gold with silver enhancement. The fixation, embedding, section pretreatments and hybridization conditions have all been optimized for legume root nodule sections, the mRNA distributions corresponding to the *gln- α* , *gln- β* and *gln- γ* genes within *P. vulgaris* root-nodule sections indicate that the assembly of the GS isoenzymes is at least partially controlled by the differential temporal and spatial expression of these genes throughout the nodule tissues during nodulation.

These results have been compared with the expression of the β -glucuronidase (GUS) gene fused with the 5' flanking regions of the *P. vulgaris* GS genes in chimaeric *Lotus corniculatus* plants. The GUS expression was demonstrated by the optimized *in situ* hybridization techniques in conjunction with immunocytochemical and GUS histochemical localization techniques.

Results indicate the control of GS gene expression is at the transcriptional level and at least partially determined by the 5' flanking regions of these genes.

Declaration: No part of this work has been submitted by me for any degree at this or any other University. All the work presented was done by me except where otherwise stated.

The copyright of this thesis rests with the author. No quotation from it should be published without prior written consent from the author, and information derived from it should be acknowledged.

LIST OF FIGURES

page

Figure 1. Glutamine Synthetase/GOGAT system for the Assimilation of Ammonia in Root Nodules	23
2. Diagram to Show Cellular Locations of Reactions of Ammonia Assimilation in Ureide Producing Legume Root Nodules	25
3. Model to Summarize the Synthesis of the Cytosolic Glutamine Synthetase Isoenzymes in <i>P. vulgaris</i> Root Nodules	27
4. The Location of GS Inserts Used to Construct cRNA Probes	47
5. Reported Levels of α , β and γ GS mRNA in <i>P. vulgaris</i> Root Nodules	110
6. Cellular Locations and Levels of GS mRNA and Protein in <i>P. vulgaris</i> Root Nodules	110

LIST OF TABLES

Table 1. Tissue Fixation Conditions	39
2. Vector Digests for Subcloning cDNA Fragments	48
3. Tissue Fixation Conditions (repeat of Table 1)	79
4. The Assessment of Fixatives	80
5. The Assessment of Embedding Media	82
6. Summary of <i>in situ</i> hybridization Results on <i>P. vulgaris</i> Root Nodules	99
7. Summary of Expression of α , β and γ , mRNAs and Protein in <i>P. vulgaris</i> Root Nodules	104
8. Summary of mRNA and GUS protein Levels in Transgenic <i>L. corniculatus</i> Root Nodules at The Intermediate to Late Stage of Development	122

LIST OF PLATES

CHAPTER 5.

Plate 1. Attachment of Early Root Nodules

2. Infected region of a *P. vulgaris* Root Nodule
3. Electron Micrographs of an Early Developing Nodule
4. Intermediate Stage Root Nodule Section
5. Electron Micrographs of Intermediate Stage Nodules
6. Late Stage Nodule Section
7. Electron Micrographs of Late Stage Nodule Sections
8. The Staining of Sections for mRNA
- 9a and 9b. The Comparison of Different Embedding Materials
- 9c. Section Stained for RNA After Hybridization
- 10a. Southern Blotting Results
- 10b. Probe Detection Strips

CHAPTER 6.

Plate 11. Sections Hybridized with a GS α cRNA Probe

12. and 13. Sections Hybridized with the GS β cRNA Probe
14. Control Sections Hybridized with a Sense Strand Probe
15. β Probe Detected with Streptavidin-Gold and Silver on Sections
16. and 17. Sections Hybridized with GS γ cRNA Probes
18. Sections Hybridized with the GS γ cRNA Probe visualized with streptavidin-Gold and Silver
19. Sections Hybridized with a Poly dTT Probe
- 20-22. Immuno-Gold and Silver Enhancement of Sections for GS Protein
- 23-25. Sections Immuno-Labelled for GS Protein and Visualized with Alkaline Phosphatase
26. Electron Micrograph of Immuno-Gold Labelled Sections for GS Protein

CHAPTER 7.

27. and 28b. Location of β /GUS mRNA in Transgenic *L. corniculatus* Plants

- 28b. *L. corniculatis* Plants Containing the β /GUS construct
Stained with X-Gluc
29. and 30a. Location of γ /GUS mRNA in transgenic *L. corniculatus*
Plants
- 30b. Sections from γ /GUS Transgenic Plants Labelled with Immuno-
Gold and Silver Enhanced for GUS Protein
31. Immuno-Labelled γ /GUS Plants
32. The Location of γ /GUS mRNA and Protein in Nodules From the
plant Line B₁B₁
33. X-Gluc Stained Sections From γ /GUS plant Line C₁E₁

LIST OF ABBREVIATIONS

AP - Alkaline Phosphatase
ATP - Adenosine Tri-Phosphate
BCIP - 5-bromo-4-chloro-3-indolyl Phosphate
bp - base pairs
B.S.A. - Bovine Serum Albumin
 $\text{Ca}^{2+}/\text{Mn}^{2+}$ - Calcium/Manganese Ions
CaC Buffer - Sodium Cacodylate Buffer
CaCl - Calcium Chloride
cDNA/RNA - complimentary RNA/DNA
cm - centimetres
CsCl - Cesium Chloride
diam. - diameter
DNA - deoxyribonucleic acid
DTT - Dithiothrietol
EDTA - ethylenediaminetetra-acetic acid, disodium salt
Fig. - Figure
Formald. - formaldehyde
g - gram
glut. - glutaraldehyde
GS - Glutamine synthetase
GUS - β -Glucuronidase
h - hour
HCl - Hydrochloric acid
HOAc - Acetic acid
I - Infected cells (of root nodules)
Kb - kilobases
KCl - potassium chloride
kD - kilodaltons
 KH_2PO_4 - potassium dihydrogen orthophosphate
kV - kilovolts
l - litre
M - Molar
 MgSO_4 - magnesium sulphate
min. - minute

ml - millilitre
mm - millimetre
mM - millimolar
NaCl - Sodium chloride
NaOAc - Sodium acetate
NaOH - Sodium hydroxide
Na₂HPO₄ - di-sodium orthophosphate
NaH₂PO₄ - Sodium di-hydrogen orthophosphate
NBT - nitro-blue tetrazolium
ng - nanograms
NH₄OAc - Ammonium acetate
NI - non-infected cells (of root nodules)
OD₆₀₀ - optical density 600
O/N - overnight
para - paraformaldehyde
pBS - bluescribe plasmid vector
PBS - Phosphate Buffered Saline
PEG - polyethylene glycol
poly A⁺ - polyadenylated
pg - picograms
rpm - revolutions per minute
RNA - ribonucleic acid
R.T. - Room Temperature
SDS - Sodium dodecyl sulphate
SDW - Sterile distilled water
Sec. - seconds
SSC. - salt, sodium citrate
TE - Tris-EDTA buffer
TLE - Tris (low) EDTA
tRNA - transfer RNA
V - volts
VB - vascular bundle
VE - vascular endodermis
v/v - volume/volume proportions
W - Watts
w/v - weight/volume proportions

INTRODUCTION

1. INTRODUCTION.

1.1. PROSPECTS FOR THE IMPROVEMENT OF NITROGEN FIXATION.

Nitrogen is essential for plant and therefore animal productivity. Before it can be used by plants, atmospheric nitrogen must first be fixed to an acceptable form, such as ammonia, by a biological, natural non-biological, or industrial process.

Natural non-biological processes such as lightning, volcanic activity and combustion account for approximately 30 mega-tonnes of nitrogen fixed annually. Industrial processes account for approximately 50 mega-tonnes fixed for fertilizer, and biologically, approximately 122 mega-tonnes are fixed annually, of which 90 mega-tonnes are from agricultural soils (Newton, 1987).

Newton (1987) reported that approximately half of the 3% increase in world cereal grain production over a 25 year period could be assigned to the exponential increase in the commercial production of nitrogen fertilizer. In many instances nitrogen is the limiting factor among soil nutrients and, within certain limits, grain yield directly depends on the amount of soil nitrogen which is available to roots of growing cereal (or forage) plants. In industrialized countries farmers apply around 80 to 120kg of nitrogen per hectare annually. The industrial processes involved in the production of ammonia have limitations; industrial production requires natural gas or liquid hydrocarbons to supply hydrogen and energy for the production of nitrogen fertilizers, the availability and cost of these components may



prove prohibitive in the future. Due to the increased use of nitrogen fertilizers, the question can be asked 'Is there a place for *Rhizobium*-based agriculture'; this is particularly relevant in a European context where the trend has been away from legume-based pastures and geared towards more intensive production. There is an ever-increasing concern over the rising levels of nitrates in water supplies in this country, and there is a realistic possibility that restrictions on the application of fertilizers to agricultural land will soon be imposed.

In developing countries the investment in construction costs, which together with the storage and transportation costs, can be prohibitive for the production of chemical fertilizers. Newton (1981) and Evans *et al.* (1985) have both suggested that the ideal model for nitrogen fixation is the biological system in which the nitrogenase catalyst is able to fix nitrogen using the energy from sunlight via photosynthesis. The present 'green' trend towards organic farming and reduction in industrial pollution suggests the importance of biological nitrogen fixation in the future will almost inevitably increase.

Sprent (1986) suggested that "many people believe in the developed world, emphasis should shift from a high input/output agriculture to a low input/output system". This would result in legumes returning to at least part of their former position in crop rotations and pastures.

Attempts to increase the nitrogen supply have and will continue to include world-wide investment into research on biological nitrogen fixation.

Just over one hundred years ago it was established that the *Rhizobium*-legume symbiosis was a widely-occurring, natural method for reducing atmospheric nitrogen to ammonia, the host legume then

incorporated the fixed nitrogen into organic compounds (Nutman, 1987).

The first conclusive demonstration that pea plants grew better in nitrogen-deficient soil if they had nodules on their roots was reported in 1886, by Hellriegel and Wilfarth. The nodules were found to be initiated by the bacterium *Bacillus radicola* now known as *Rhizobium leguminosarum*. A patent for the biotechnology to produce a *Rhizobium* inoculum was subsequently taken out (Sprent, 1986).

Today molecular biology techniques have enabled some of the genes associated with nodulation to be successfully transferred and expressed in transgenic plants. With the application of such techniques the ability of legumes and even non-legumes to fix nitrogen at an ever increasing level of efficiency is becoming an important topic for research.

Johnston *et al.* (1987) suggested that "The symbiotic interaction between leguminous plants and bacteria of the genera *Rhizobium* and *Bradyrhizobium* was the single most important beneficial association between plants and bacteria in agriculture" and also that "over and above its agronomic significance the legume-*Rhizobium* symbiosis is of interest because it represents a complex programme of biochemical and morphological differentiation in the two different partners. It thus offers potential as a model system for the analysis of differentiation both in bacteria and in plants and for the study of the signals that pass between the two kinds of organisms".

The developing legume root nodule therefore provides an ideal system in which to study plant gene expression. A variety of assays have been carried out on legume root nodules in order to ascertain their biochemical and genetic functioning. Most of these studies have

however, been carried out on homogenized tissue, although many structural investigations have also been undertaken. *In situ* studies at the protein and mRNA level, can however directly associate the control of particular genes, and the ultimate destination of their product within the particular cell types which are unique in the *Rhizobium*-legume symbiosis.

1.2. THE CLASSIFICATION, DEVELOPMENT AND STRUCTURE OF ROOT NODULES.

The complexity of root nodules was aptly summarised by Syono et al. (1976) in the statement "the development of root nodules reflects the genetic, structural and physiological complexities of an intimate relationship between prokaryotic bacteria and the eukaryotic angiosperm partner".

The symbiotic association between the legume and bacteria starts when the gram-negative, soil-living bacteria are attracted towards legume roots shortly after seed germination. The bacteria invade the plant root within an infection thread, and are subsequently released into the legume-host cells. Some cells become infected by the multiplying *Rhizobium*, which form bacteroids contained within a peribacteroid membrane within the host plant cell, whilst other cells remain uninfected. The infection process stimulates a chain of events resulting in the physiological and biochemical development of a functional root nodule, capable of fixing atmospheric nitrogen into ammonia and subsequently assimilating this ammonia into an appropriate form to be transported through the plant. The nodule protects the bacteroids from competing soil micro-organisms whilst the plant host provides a source of minerals, water and carbon via a vascular system to support the nitrogen fixation.

1.2.1. Root Nodule Classification.

Legume root nodules vary in their structure and development. This variation is due to different legume species, and in particular the strain of *Rhizobium* or *Bradyrhizobium* infecting the particular legume.

Nodules are often classified by their shape and pattern of development. Two main developmental and structural types of root nodule occur in legumes; Verma and Long (1983) described these as spherical or oval, such as those found on kidney bean (*Phaseolus vulgaris*) roots, and club shaped, cylindrical or elongate such as those found on pea (*Pisum sativum*) roots.

The spherical nodules have a relatively short, determinate life. The rhizobia infect cells in the centre of the forming nodule which are surrounded by a ring of cortical and endodermal cells; once formed this determinate structure no longer divides. Meristematic activity ceases soon after infection, and most of the increase in nodule size results from the expansion of the infected cells.

In contrast, the longitudinal indeterminate nodules have a persistent meristem which continues to divide while the early-infected cells are senescing; the nodule continues to develop for approximately five weeks.

Root nodules can also be classified by the form in which they export fixed nitrogen to the rest of the host plant. Tropical legumes, such as soybean, cowpea and kidney beans, export the fixed nitrogen in the form of ureides allantoin and allantoic acid, from the purine metabolic pathway, whilst temperate legumes such as pea, lupin, and alfalfa, export fixed nitrogen in the form of the amides asparagine and glutamine.

1.2.2. Early Root Nodule Development.

The early development of legume root nodules, whether spherical or elongate, can be divided into a series of stages; attraction, invasion and growth of the infection thread and release of the rhizobia and host plant infection. The general structure of both nodule types is described in the following section (1.2.3), followed by a more specific description of the two nodule types.

1.2.2.1. Attraction.

The *Rhizobium* live in the rhizosphere of their potential legume hosts, where exudates from the legume roots stimulate them to proliferate. Recognition and attachment of the *Rhizobium* to the epidermal root cells of the legume host is thought to involve a cross reaction, such as lectins on the the root hairs of the host attracting the rhizobia (Bauer, 1981; Graham, 1988). Recently Diaz et al. (1989) have successfully introduced a pea lectin gene into clover using an *Agrobacterium rhizogenes* vector. The resulting transformants exhibited the early stages of infection and nodulation when inoculated with *Rhizobium leguminosarum*, which is normally specific to peas. This demonstrates that lectins play a major role in the host specific attraction/infection process, although few functional nodules resulted from this 'cross infection' indicating lectins are not the only factors involved.

The bacterial recognition and response is also a very important factor in the early attraction and infection process. This bacterial recognition and response is known to be at least partly mediated by the bacterial *nod D* gene. The *nod* genes are a cluster of genes, located on

the rhizobial symbiotic plasmid involved in the early stages of nodulation. The induction of the *nod D* gene has been reported to be triggered by flavonoids or isoflavonoids secreted from the host legume roots (Firmin *et al.*, 1987). The flavone luteolin has been shown to be the most important inducer of the *R. meliloti nod* genes present in alfalfa root exudate (Peters, Frost and Long, 1986), and the flavone glucoside apigenin-7-O-glucoside, isolated from peas, was reported to induce the *nod* genes in *Rhizobium leguminosarum* bv. *viciae*, in addition to 3 other flavones and 3 flavanones (Firmin *et al.*, 1986). However, the flavonol kaempferol and the isoflavones genestein and daidzein, have been demonstrated to have 'anti-inducing', effects on *Rhizobium leguminosarum* bv. *viciae* (Firmin *et al.*, 1986). Djordevic *et al.* (1987) have demonstrated coumarins such as umbelliferone reduced the effect of inducers on the induction of the *nod* genes of *Rhizobium leguminosarum* bv. *trifolii*.

Downie and Johnston (1988) demonstrated that *nod D* induces the synthesis of *nod ABC* gene product which is a soluble factor required for root hair curling and possibly involved in eliciting the development of the nodule meristem.

1.2.2.2. Root Hair Invasion and Growth of the Infection Thread.

Rhizobial infection of the legume root hair is affected by a variety of factors such as temperature, pH, mineral content of the soil, the number of rhizobia present in the soil, the degree of competition with other soil bacteria, and the specificity of the rhizobial strain for the particular potential host. Sanders *et al.* (1978) suggested rhizobial polysaccharides are implicated in the host

specificity. Haack (1964), demonstrated an average of 2.8% of pea root hairs became infected, out of a total of 20,000.

The first sign of plant/rhizobial recognition and attachment is the swelling of the root hair cell wall. This is due to the formation of callus, and on close examination increased cytoplasmic streaming of the associated cytoplasm is evident. Externally, curling and branching of the infected root hair results from the displacement of cell wall growth by the bacteria and can result in a curvature of 360° or more (Callaham and Torrey, 1981).

The infection thread is formed as the rhizobia penetrate the root hair cell wall and make contact with the host cell plasma membrane; this causes redirected cell wall growth resulting in invagination of the root hair cell wall, producing a tubular infection thread. Callaham and Torrey (1981) demonstrated that the tubular infection thread containing the bacteria was sheathed by a plant cell membrane and plant cell wall materials. VandenBosch *et.al.* (1989) have identified an infection thread matrix component which occurs in infected roots and at intercellular spaces where cell plates fuse with the parent cell wall. These intercellular spaces have been shown to contain pectic components involved in the loosening and degrading of cell walls (Moore and Staehelm, 1988). Infection threads, which are also often located at 3 way cell:cell junctions, contain the same soluble matrix material. It seems likely therefore, that degrading enzymes are used in the cell to cell movement of the infection thread, and that the infection thread makes an intracellular tunnel through the nodule cortex using these loosening and degrading enzymes.

The bacteria contained within this infection thread are unable to

fix nitrogen at this stage (de Faria *et al.*, 1986), and only those at the advancing end of the infection thread appear to divide, resulting in a growth rate of up to 7 μ m/hour (Robertson and Farnden, 1980).

The infection thread grows through 3-5 layers of outer cortical cells with the aid of the pectolytic enzymes loosening the cell walls, (VandenBosch *et al.*, 1989) and meristematic activity is initiated in the layers of cells directly in front of the infection thread.

1.2.2.3. Release of the *Rhizobium* and Host Plant Infection.

Cells directly in front of the tip of the infection thread divide and differentiate to form the nodule tissue. The bacteria are released into the predominantly polyploid central meristematic cells by an endocytotic process in which the bacteria push out the plasmalemma, the infection thread pinches in behind and encloses the bacteria in the host plasma membrane. Robertson and Farnden (1980) reported that the end of the infection thread in lupin and soybean is very thin or even absent, consisting of only unwallled and partially electron translucent protrusions. Within peas there are unwallled droplets of heavily staining matrix around the tip of the infection thread bound by a plasma membrane, which represent the sites of the bacterial release into the host cell cytoplasm (Newcomb, 1976). The compositional changes at the tip of the infection thread have been suggested to be a result of a change in the function of the Golgi apparatus whereby the rate of membrane synthesis remains constant or increases, whilst the rate of deposit decreases (Goodchild and Bergersen, 1966), together with increased cellulytic and pectolytic activity. Once the individual bacterial cells are internalized to the plant cell cytoplasm, they

develop into nitrogen-fixing endosymbiont bacteroids enclosed in the plant-derived peribacteroid membrane. These membrane envelopes may protect the bacteria from the antibiotic substances in the plant cytoplasm (Dixon, 1969).

Goodchild (1977) suggested that the polyploid cells, with considerably enlarged nuclei and nucleoli, tend to be those which become specifically infected, whilst other diploid cells remain uninfected throughout the life of the nodule. Libbenga and Bogers (1974) have suggested these polyploid cells result from endoreduplication, stimulated by bacterial hormones. However, Verma and Long (1983) have demonstrated that the ploidy of the cells is not the factor determining which cells become infected and which do not.

The number of bacteria within each peribacteroid membrane is thought to be under host control (Dart, 1977), and varies between plant species, *P. vulgaris* has up to 6, whilst peas usually 1 or 2 (Newcomb, 1981). It has been suggested this may be determined by the host peribacteroid membrane (Verma and Long (1983). As the bacteria multiply the mitochondria and amyloplasts in the infected cells are pushed to the periphery, particularly of the cell adjacent to the intercellular spaces (Dart 1975). Endoplasmic reticulum, Golgi and small cytoplasmic vesicles are often seen in thin sections of newly-infected cells and throughout the cytoplasm of more heavily-infected cells, where they may play a role in the synthesis of the plasma membrane as the infected cells expand.

1.2.3. Root Nodule Structure.

1.2.3.1. General Structure.

The development of root nodules varies, to some extent, with the particular nodule type and between species, (as already discussed), however all have basic structural similarities. Developing root nodules generally consist of:

1. a central region of infected cells interspersed with smaller noninfected cells. The infected cells are packed with bacteroids, which are enclosed in a plasma membrane.
2. a meristematic region of dividing cells. The location and lifetime of this region varies with different the nodule types.
3. an outer cortical layer, which may contain specialised parenchyma cells, and contains a vascular system forming a network around the centrally infected region of the nodule.
4. an outer layer of callus-like cells often forming lenticels or ridges around the outside of the nodule.

The vascular system follows a similar pattern of development in both nodule types, and this common development is outlined in 1.2.3.2., with the specific aspects dealt with separately in 1.2.3.3. and 1.2.3.4.

1.2.3.2. The Root Nodule Vascular System.

Pate *et al.* (1969) demonstrated that a root nodule was capable of a nitrogen turnover 3-10 times its own nitrogen content per day. As it

does not accumulate this nitrogen, the nodule requires an extremely efficient export system.

The peripheral vascular network of a root nodule covers only a few percent of the total nodule surface area. Central nodule cells are typically 0.3-1.3mm away from the nearest vascular tissue. Vascular strands develop to connect the root vascular tissue to the provascular strands of the developing nodule. The strands are initiated close to the central polyploid meristematic zone, and form as the volume of infected tissue increases. Differentiation into xylem and phloem elements begins at the root connection and progresses towards the nodule apex. The typical vascular bundle consists of centrifugally-orientated xylem elements, surrounded by centripetally arranged patches of phloem. Each vascular strand has its own endodermis and Casparian strip similar in structure, and joined to, the endodermis of the root vascular system. Within the endodermis the xylem and phloem elements are surrounded by pericycle, in some legumes cells in this pericycle layer contain dense cytoplasm and elaborate cell wall ingrowths, and are often known as transfer cells. These transfer cells appear to play a role in the amino acid transport away from the nodule to the xylem, and supply photosynthate from the phloem to the nodule cells (Goodchild, 1977; Newcomb and Peterson, 1979). The vascular bundles develop outside the multiplying cortical cells to form a closed network around the outer parenchymous region of the developing nodule.

Each nodule has a further endodermal layer which differentiates in the cortex of the root outside and beyond the endodermal layer of each vascular strand. Cells outside the endodermis are modified in various ways to form a specialized corky layer of cells with thickened walls.

Frazer (1942) suggested that the layers of thickened cells may provide a diffusion barrier which restricts the flow of oxygen in and out of the nodule. The outermost layer of lenticels, or ridges of loosely packed cells, appear to play a role in gaseous diffusion, these are located immediately above the vascular strands within the nodule (Bergersen and Goodchild, 1973a).

Pate *et al.* (1969) suggested that the conventional source:sink movement of substrates in and out of the nodule operates; the sieve tubes of the phloem import substrates, and follow the symplastic route through the pericycle, endodermis and cortex to the sites of consumption of sugars in the bacteroid tissue. Newcomb (1976) suggested that transfer cells, located next to the vascular cells in some nodules, play an important role in this transport. Transfer cells have ingrowths in the secondary cell wall which increase the surface area of the plasma membrane. Such cells are adapted for the short distance movement of solutes. Pericycle transfer cells are seen in the nodular vascular bundles of peas, alfalfa, clover and lupins (Pate *et al.*, 1969). These transfer cells are thought to facilitate the movement of sugars from the sieve elements to the infected cells, and also facilitate the export of amides and amino acids to the xylem elements of the nodular vascular bundles. Pericycle, xylem and phloem transfer cells have been reported in root tissue adjacent to the nodule in pea, soybean, broad bean, mung bean, and french bean (Newcomb and Peterson, 1979).

1.2.3.3. Structure of Elongate/Indeterminate Nodules.

Indeterminate nodules, such as those formed by peas and clover, are formed by infection threads which turn back on themselves, at the

tip in the infected region of the nodule, towards the epidermis of the plant releasing the rhizobia into the inner region of the newly formed nodule meristem. New meristematic activity is constantly initiated to form an apical meristem over a period of 5-8 weeks. The nodules are characteristically oval in shape and consist of several distinct regions:

1. an active meristematic zone close to the nodule apex.
2. a zone of infection/invasion.
3. an early-symbiotic zone consisting of cells containing dividing bacteroids and starch.
4. a late-symbiotic zone, containing cells filled with bacteroids, fixing nitrogen, pink with leghaemoglobin and containing much less starch, than the younger cells.
5. a senescent zone.

The mature nodule can also be separated into zones by its colour; the distal regions (1 and 2) are white, the middle regions (3 and 4) pink due to the leghaemoglobin content, and the proximal region (5) green/brown due to the degrading leghaemoglobin.

The active meristematic region consists of relatively small cells with numerous small vacuoles, plastids and starch, few mitochondria, and a lot of free ribosomes and endoplasmic reticulum.

The infection threads pass very close to, but not through, the cell nuclei in the zone of infection. Newcomb (1976), suggested that the products of starch degradation are assimilated by the rhizobia, and the cells may act as an oxygen sink or as a storage tissue where starch may be metabolised. The infected region of the nodule consists of large cells packed with bacteroids and rectangular starch grains around the

cell edges, these cells are interspersed with smaller non-infected cells which are, however, larger than those in the meristem.

The senescent region, close to the plant root, consists of dark green-black cells which progressively lose their cell walls and degrade. The vascular system forms an open network from the plant root to the growing meristem.

1.2.3.4. Structure of Spherical Nodules.

Determinate nodules, such as those associated with soybean and red kidney bean, are characteristically spherical, and have a shorter lifespan than the indeterminate, elongate nodules.

Determinate nodules are first visible as small, milky-white protrusions, 9-12 days after inoculation. As they develop they form a pinkish-coloured sphere which eventually degenerates into a brown colour over a period of 3-4 weeks.

The infection thread grows inter and intra cellularly through 5-8 layers of cells, passing close to but not through the nuclei. Mitochondria and rough endoplasmic reticulum are often seen associated with the infection thread.

The nodule forms 4 main radial zones; the cortical cells, vascular strands, nodule meristem, and the central infected region.

The central cells in a young nodule consist of infected cells, containing a few bacteroids in the cytoplasm, interspersed with smaller noninfected cells, surrounded by parenchyma cells with large vacuoles. The division of the infected cells is completed within the first few days after infection, and the subsequent growth of the nodule is largely due to cell enlargement as the bacteroids multiply. The non-

infected cells in the infected region contain large starch grains which are possibly energy reserves, and are gradually used up as the central infected tissue enlarges with the rapidly multiplying rhizobia. The nodule meristem surrounds the infected cells and consists of small cells with dense cytoplasm and little vacuolation.

As the rapid, mitotic activity in the cortical cells ceases, symbiotic growth takes over. The bacteroids multiply within their peribacteroid membrane causing the infected cells to swell.

The nodule is fully developed 18-20 days after infection. At this stage the nodules have a pinkish external appearance with ridges of white callus-like parenchyma cells around the outside. Within this is a single layer of endodermal cells, many of which contain calcium oxalate crystals (Frazer, 1942). A cambium-like cell layer separates the cortex and vascular bundles from the central portion of the nodule, which consists of swollen, infected cells interspersed with smaller non-infected cells with large vacuoles. The infected cells are packed with bacteroids, and have very small or no vacuoles and a prominent central nucleus. The non-infected cells, in contrast, are small with a single large vacuole, a peripherally located nucleus, several large starch grains, which decrease with nodule age, and peroxisomes which increase in size and number with age.

The nodules actively fix dinitrogen from approximately the 10th day after infection up to the 26th day. This usually coincides with the pod-filling stage of the plant. The nodules then begin to senesce from the centre of the nodule outwards.

1.3. THE BIOCHEMISTRY OF ROOT NODULES.

Spherical and elongate nodules share similar nitrogen fixation pathways, utilising the nitrogenase enzyme in the presence of leghaemoglobin within the bacteroids for reducing atmospheric dinitrogen to ammonia. The subsequent assimilation of the ammonia, and the form in which the ammonia is transported from the nodules via the xylem to the rest of the plant, differs between nodule species.

1.3.1.. Energy Requirements for Nitrogen Fixation.

Although it is well established that nitrogen fixation requires photosynthetic products (Bergersen, 1977; Evans and Barber, 1977), the exact form of carbohydrate supplied to the bacteroids is not fully established. All infected cells are adjacent to non-infected cells, which contain large numbers of starch grains. Whether these are mobilised to provide a supply of carbohydrate to the bacteroids is not certain.

The conversion of atmospheric nitrogen to ammonia requires energy;

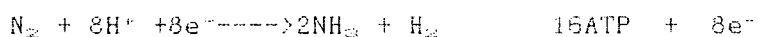

0.55 moles of glucose (21 moles of ATP) are required for the fixation of 1 mole of nitrogen (Pate *et al.*, 1980). The cost of nitrogen fixation to a particular legume varies with the exact metabolic pathway utilized, the presence of uptake hydrogenase and the efficiency of partitioning of electrons.

Up to 22% of the net photosynthate produced by the host plant, may be used during maximum nitrogen fixation.

The enzyme phosphoenolpyruvate carboxylase shows a rapid increase

in specific activity during nodule development (Lawrie and Wheeler, 1975). This enzyme is found in the cytosol of legume nodules, (Vance, 1983) and its main function is likely to be in replenishing the carbon removed from the nodules by the bacteroids.

1.3.2. The Nitrogenase Enzyme.

Bergersen (1974) demonstrated that the bacteroids in legume root nodules contained all the necessary enzyme systems for the reduction of nitrogen to ammonia. Bergersen and Turner (1967) demonstrated that nitrogen fixation was continued by bacteroids isolated from infected nodule cells and was therefore independent of them.

The most important enzyme required in this system is nitrogenase. Characterised by Winter and Burris (1976), the nitrogenase enzymes from *R. lupini* and *R. japonicum* are considered to be representative of all the nitrogenases. The enzyme is made up of two components, a molybdenum-ferrous-protein M_r 200,000 containing an acid-labile sulphur group, and a ferrous protein M_r 50,000-65,000 also containing an acid-labile sulphur. Both oxygen-sensitive metallo-protein components are required for enzyme activity, excess oxygen results in their irreversible inactivation.

Nitrogenase requires ATP, produced by oxidative phosphorylation, and an electron transport system, to function efficiently in the nodule.

The nature of the electron transport system is not fully established; Robertson and Farnden (1980) suggest that it may be similar to that proposed by Yates (1980) for *Azobacter* in which NADH and a chemiosmotic gradient across the membrane are used to reduce a

flavodoxin semiquinone to its hydroquinone form, which in turn reduces nitrogenase.

1.3.3. Uptake Hydrogenase.

Dihydrogen is evolved as a result of the nitrogenase reaction (Bulen and Le Compte, 1966). Although most strains of *Rhizobium* form nodules which evolve hydrogen and release it into the atmosphere, there are a few that form nodules which do not (Schubert and Evans, 1976). These strains recycle dihydrogen (Dixon, 1972); they contain an 'uptake' hydrogenase which is able to recycle the dihydrogen resulting from the nitrogenase reaction and therefore conserve hydrogen (Evans *et al.* 1979). The rhizobia which are able to re-cycle dihydrogen, synthesize the necessary enzymes to activate the dihydrogen and transfer electrons via the bacteroid electron transport chain to oxygen. Harker *et al.* (1984) isolated the hydrogenase from *B. japonicum* and demonstrated that it was composed of two subunits with relative molecular masses of 60,000 and 30,000. The proximal electron acceptor has yet to be identified.

The possible advantages of this 'uptake' hydrogenase are not fully established. Yates (1980) and Albrecht *et al.*, (1979) reported that soybeans, inoculated with *R. japonicum* strains able to synthesize the uptake hydrogenases, could recycle the hydrogen evolved, although they were able to fix more nitrogen and produced greater yields than those inoculated with strains lacking hydrogen uptake capacity. Cunningham *et al.* (1985) reported that the re-cycling of dihydrogen resulted in no significant increase in plant growth, whilst Evans *et al.* (1985) demonstrated a significant increase in plant growth due to the recycling

of dihydrogen.

Attempts are now being made to identify the dihydrogen uptake (*hup*) genes in *hup*⁺ *Rhizobia* and transfer them to *hup*⁻ *Rhizobia* (Evans *et al.*, 1987).

1.3.4. Oxygen Metabolism.

Oxygen is required for the synthesis of ATP in the bacteroids and the plant host cells. Bergersen (1982) showed that in excised nodules, nitrogen fixation and respiration were markedly increased by oxygen partial pressures above atmospheric. Maximum nitrogenase activity is however achieved at oxygen partial pressures of 40-50% that of atmospheric level, higher levels inactivate the nitrogenase enzyme.

A diffusion barrier in the nodule periphery controls the access of oxygen into the nodule. This barrier, located within the nodule cortex, is sensitive to environmental changes (Bergersen, 1982). Evans *et al.* (1987) has suggested that the increase in nitrogenase activity at raised oxygen partial pressures, as reported by Bergersen (1982), may be caused by the effect of this diffusion barrier located in the nodule periphery in response to the detachment of the nodules. However Minchin *et al.* (1985) demonstrated that soybean and pea nodules were not affected by the alteration of oxygen partial pressures to 10, 21 and 30% atmospheric levels. Further investigation in this area is obviously required to clarify this conflicting evidence.

1.3.5. Leghaemoglobin.

A myoglobin-like compound, leghaemoglobin, facilitates the diffusion of bound oxygen to the bacteroids, and is responsible for the

characteristic pink coloration of root nodules. A monomeric haemoprotein of M_r 15,000-17,000, leghaemoglobin was thought to be, with the exception of a 35 kD molecule detected by Verma and Long (1983), the only molecule restricted to infected cells of the root nodule. However more recently VandenBosch and Newcomb (1988) have demonstrated the presence of leghaemoglobin, by immuno-gold labelling, in both the infected and non-infected cells of soybean root nodules. They reported the leghaemoglobin was approximately four times more concentrated in the infected cells, but was present in the cytosol of both infected and non-infected cells and in both types of nuclei, it was not however present in any other organelles of either cell type. It has been proposed that the function of leghaemoglobin is to facilitate the diffusion of oxygen to the bacteroids at a sufficient rate to maintain aerobically supported nitrogen fixation.

The globin or the apoprotein portion of leghaemoglobin, is coded for by the host plant chromosomes (Dilworth and Williams, 1969; Verma *et al.*, 1981), the protohaem moiety however is thought to be synthesized by the *Rhizobium* (Godfrey *et al.*, 1975). Soybean leghaemoglobin is encoded by a small multigene family consisting of four functional genes encoding four major species of leghaemoglobin. The *P. vulgaris* leghaemoglobin sequence has 76% homology with the soybean leghaemoglobin component 'a' (Lehtovaara and Ellfolk, 1974).

On the basis of its coding sequence Landsman *et al.* (1986) proposed that leghaemoglobin may have evolved from a common plant/animal ancestor.

1.3.6. The Assimilation of Ammonia in the Host Plant Cells.

LaRue *et al.*, (1984) reported that, in contrast to the infected cells of root nodules, "there is little information on the metabolism of uninfected plant root nodule cells". There is, however, strong evidence to suggest that several important metabolic pathways involved in nitrogen fixation are located within these non-infected cells. Excess fixed nitrogen in growing media is known to depress nodulation but, although the control of this is not fully defined, the host legume is known to play an important role in the regulation.

Ammonia is assimilated in the legume cytosol by a coupled glutamine synthetase/glutamate synthase reaction, illustrated in Figure 1.

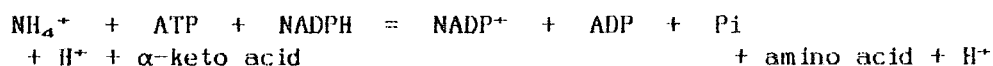
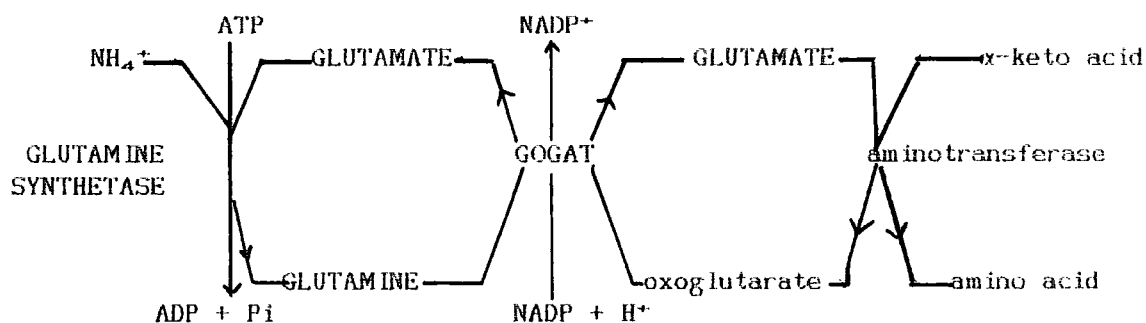
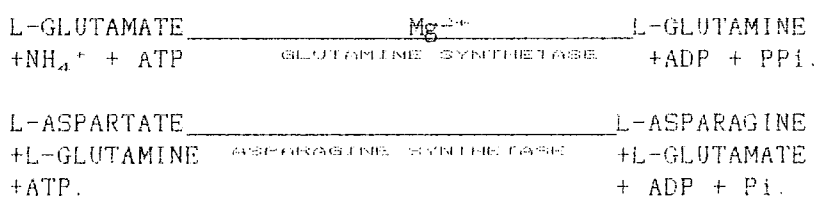

Figure 1. The glutamine synthetase/GOGAT system for the assimilation of ammonia in root nodules. (From Dixon and Wheeler, 1986).

Measurements of glutamine synthetase (GS) and glutamate synthase activity in nodules (Boland *et al.*, 1978; Boland and Benny, 1977; Dilworth, 1980), and the observations that the bacteroids contain relatively low levels of these enzymes and excrete ammonia, support the suggestions by these authors that plants assimilate ammonia produced in

nitrogen fixation via the system outlined in Figure 1. Cullimore *et al.* (1983) demonstrated that the activity of GS in *P. vulgaris* nodules was significantly higher than that in roots. Lara *et al.* (1984) demonstrated that this rise was associated with the appearance of a nodule-specific form of GS in *P. vulgaris* nodules, although the increased levels in other nodules has not been associated with a particular nodule-specific form (the specific isoenzymes of GS are described in detail in the following section). The increased activity of GS follows a similar time course to the accumulation of leghaemoglobin and nitrogenase in the nodule (Robertson *et al.*, 1975a).

Schubert (1986) and Pate and Atkins (1983), have identified the primary nitrogenous compounds exported from most legumes. The majority of temperate legumes from the indeterminate nodule forming group, of which lupins and peas are typical, export nitrogen in the form of amides, such as, asparagine and glutamine. The GS reaction may be coupled with the asparagine synthetase reaction to produce asparagine as the export product.



Asparagine synthetase has been detected in lupin nodules (Boland *et al.*, 1979). Aspartate, which is a substrate for the asparagine synthesis, has been reported to be supplied by the aspartate aminosaminase reaction in which oxaloacetate and glutamine react to

form aspartate and alpha-ketoglutarate (Scott *et al.*, 1982).

Tropical legumes, such as soybean, and kidney bean (*P. vulgaris*), export nitrogen in the form of the ureides, allantoin and allantoic acid. These ureides have a higher nitrogen to carbon ratio (4:4), than the amides asparagine, (2:4), and glutamine, (2:5), and can therefore use carbon more efficiently (Sprent, 1984). Ureide synthesis appears to be confined to the non-infected cells, where significant enlargement of the peroxisomes and proliferation of the smooth endoplasmic reticulum are evident (Newcomb and Tandem, 1981). Peroxisomes in soybean nodules, which convert uric acid to allantoin, appear to be confined to the non-infected cells (Hanks *et al.*, 1981). VandenBosch *et al.* (1986) using uricase immunocytochemistry, have demonstrated the presence of uricase in the peroxisomes of non-infected cells in root nodules. Uricase and xanthine dehydrogenase, required to produce these ureides, are not generally found in roots and are therefore good examples of nodulins. Figure 2 outlines the proposed reactions and the cellular locations of the reactions involved in ammonia assimilation in ureide-producing legumes.

The ureides are transported from the nodules, via the xylem to the leaves where they are degraded to release nitrogenous compounds to be incorporated into proteins.

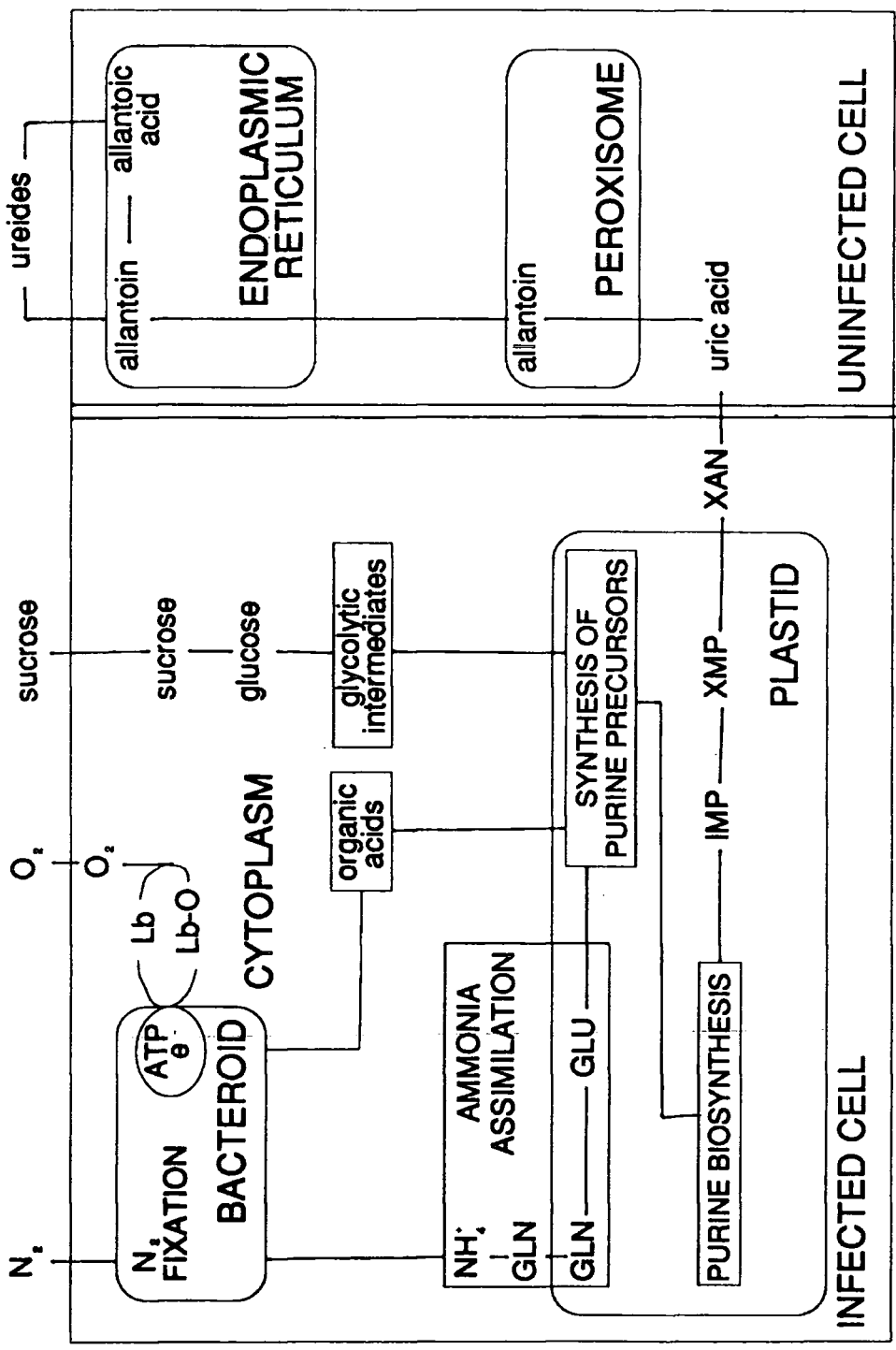

Fig. 2. Diagram to show the proposed cellular locations of the reactions of ammonia assimilation *de novo* purine synthesis and ureide biogenesis in nodules of ureide-producing legumes, (from Schubert, 1986). Lb—leghaemoglobin, GLN—glutamine, GLU—glutamate, IMP—inosine monophosphate, XMP—xanthosine monophosphate, XAN—xanthine.

1.4. GLUTAMINE SYNTHETASE

In higher plants glutamine synthetase (GS) plays a key role in the assimilation of ammonia into organic nitrogen. GS can account for up to 2% of total soluble protein in legumes and is present in both the cytosol and chloroplasts (Forde and Cullimore, 1989), although over 95% of nodule GS activity is present in the plant cell cytosol (Mifflin and Cullimore, 1984). In *P. vulgaris* GS exists in a number of isoenzymic forms which are made up of eight subunits M_r 41 000-45 000. The levels of GS rise in conjunction with rhizobial infection, increase in leghaemoglobin content and the onset of dinitrogen fixation in *P. vulgaris* root nodules (Lara *et al.* 1983).

Hirel *et al.* (1984) demonstrated that the cytosolic GS isoforms in *P. vulgaris* were immunologically different from the heavier chloroplastic GS. These two distinct chloroplastic and cytosolic forms have relative molecular masses of 45 kD and 40 kD respectively, and can be separated by ion exchange chromatography (McNally and Hirel, 1983).

Lara *et al.* (1984b) separated two isoenzymes of GS from *P. vulgaris* which eluted at different positions on DEAE-Sephacel, but were both cytosolic, and had subunits with similar molecular masses of 40 kD. However, only one of these isoenzymes had a counterpart in leaves and roots, suggesting that the other was nodule-specific. The 16 fold increase in GS activity which occurs during nodulation was found to be entirely due to the appearance of this nodule-specific form GS_n (Lara *et al.*, 1984b). These same authors used two-dimensional electrophoresis (isoelectric focussing followed by SDS-PAGE) to examine the composition of the GS isoenzymes in *P. vulgaris*. They demonstrated that nodules

contained two GS polypeptides of molecular mass 40 kD, (γ and β). They reported that γ was nodule specific, and absent in roots and leaves, whilst β was found in roots, nodules and leaves. A third 40 kD GS polypeptide, α , was also detected in roots, and at higher levels in embryos (Ortega *et al.*, 1986). Padilla *et al.* (1987) have more recently detected this α polypeptide at low levels in nodules.

The nodule-specific GS isoenzyme, GS_{n1} , has been shown to consist of both γ and β subunits, whilst GS_{n2} found in both roots and nodules is predominantly composed of the β subunit (Lara *et al.* 1984a).

A further plastid located GS subunit *P. vulgaris* has been detected in chloroplasts, (Cullimore and Bennett, 1988).

Rhizobium produces two GS isoenzymes: a dodecameric isoenzyme (GS_1), and a hexameric enzyme (GS_{1r}). In bacteroids the dodecameric enzyme is repressed by adenylation, and the hexameric isoenzyme is absent (Robertson and Farnden, 1980). The GS involved in assimilation of ammonium from symbiotic dinitrogen fixation is therefore almost entirely of plant origin.

Fig.3. Model to summarize the synthesis of the cytosolic glutamine synthetase isoenzymes in *P. vulgaris* roots and nodules.

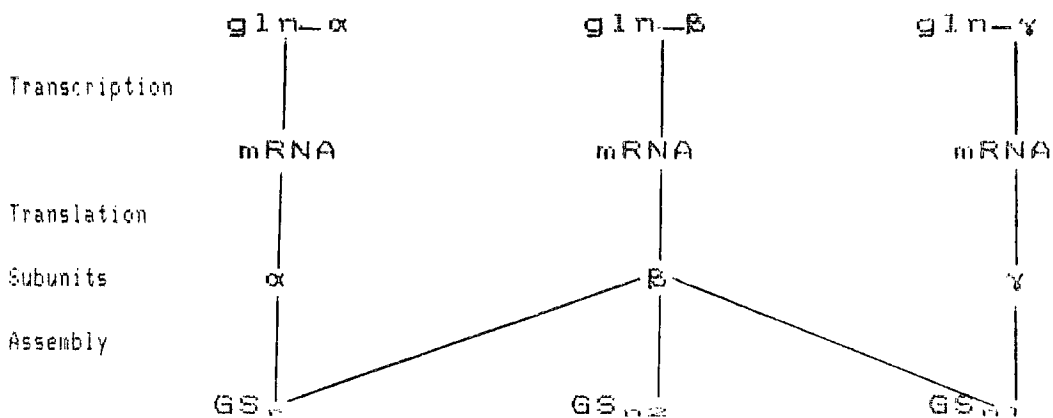

1.4.1. The Genes Encoding Glutamine Synthetase

Four full-length cDNA clones encoding the cytosolic GS subunits which form the isozymes, outlined in Figure 3, in *P. vulgaris* have been obtained; pcGS α -1, pcGS β -1, pcGS γ -1 and pcGS δ -1 (Gebhardt *et al.*, 1986; Lightfoot *et al.*, 1988; Bennett *et al.*, 1989). These four cDNAs were isolated from different plant organs; pcGS β -1 and pcGS α -1 from roots (Gebhardt *et al.*, 1986), pcGS γ -1 from nodules and pcGS δ -1 from leaves (Lightfoot *et al.*, 1988).

The sequences were shown by Gebhardt *et al.* (1986) to hybridize to different restriction fragments, suggesting that they encoded mRNAs from different genes. This demonstrated that GS in *P. vulgaris* is encoded by a small multigene family containing at least four expressed genes. pcGS α -1, pcGS β -1 pcGS γ -1 and pcGS- δ . The cDNA clones for the cytosolic polypeptides, pcGS α -1, pcGS β -1 and pcGS γ -1, were shown to code for the subunits with 85% or more sequence homology. The 5' and 3' ends, however, showed almost complete divergence. An S1 RNase protection technique was used to discriminate between the similar GS sequences, (Gebhardt *et al.* 1986) and to quantify the different GS mRNAs in total poly A⁺ RNA from nodules roots and leaves. The authors demonstrated that pcGS γ mRNA was only present in nodules, pcGS β -1 mRNA in all three organs, and pcGS α -1 mRNA occurred in roots and leaves only. More recently Bennett *et al.* (1989) have demonstrated these mRNAs correspond to the different cytosolic polypeptides, and it thus appears that pcGS α -1, pcGS β -1 and pcGS γ -1 encode α , β and γ polypeptides, thus forming a multigene family of cytosolic GS genes.

1.4.2. Glutamine Synthetase Expression in Developing Nodules..

An S1 RNase protection technique was used to demonstrate the relative abundance of γ and β at different stages of nodulation (Gebhardt *et al.*, 1986). They reported that the abundance of the *gln*- β mRNA remained constant throughout nodulation whilst *gln*- γ mRNA was first detectable around 16 days after inoculation, and reached a maximum around 19 days. The increase in the γ polypeptide followed this increase in mRNA levels and, they suggested that it was regulated by induction of the GS γ gene. Gebhardt *et al.* (1986), reported the *pcGS α -1* mRNA was confined to roots and leaves, and that this corresponded to the distribution of the α polypeptide, although Bennett *et al.* (1989), have more recently demonstrated traces of the α mRNA are present in nodules and possibly decline during nodulation. This decline of the α mRNA is similar to that observed by Padilla *et al.* (1987), who also demonstrated a similar time course of events to those reported by Gebhardt *et al.* (1986) using *in vitro* translation of the products of *P. vulgaris* mRNAs.

1.4.3. Assembly of Glutamine Synthetase Polypeptides in *P. vulgaris*

Root nodules

Initially it was suspected that the γ and β GS subunits assembled into either a γ rich octamer, in the case of GS₁₁, the nodule-specific GS, or as β subunits alone in the case of the root and nodule located GS GS₁₂. It has, however, been suggested that all nine possible combinations of γ and β subunits (γ_8 , $\gamma_7\beta_1$, $\gamma_6\beta_2$, $\gamma_5\beta_3$, $\gamma_4\beta_4$, $\gamma_3\beta_5$, $\gamma_2\beta_6$, $\gamma_1\beta_7$, β_8) may be present in nodules (Robert and Wong, 1986). Using ion exchange HPLC chromatography Cullimore and Bennett (1988),

have reported up to three activity peaks of cytosolic GS in *P. vulgaris*; one containing a high proportion of γ subunits, a second with approximately equal amounts of γ and β subunits, and a third consisting of all β subunits. The assembly of the α polypeptide has yet to be investigated.

1.4.4. The Regulation of GS Gene Expression in *P. vulgaris* root nodules.

Mutant strains of *Rhizobium* which induce trace amounts of leghaemoglobin, have been reported to induce trace amounts of the nodule-specific GS₁₁₁ (Lara *et al.*, 1984a).

Fix⁻ mutants of *Rhizobium* or *Bradyrhizobium*, which produce non-fixing nodules, have been reported to contain less than 5% of this nodule-specific GS₁₁₁, found in normal nodules, and 50% less of the root and nodule located GS₁₁₂, (Lara *et al.*, 1984b). Padilla *et al.* (1987) have however reported results which indicate that the GS polypeptides appear 3 days or more in advance of nitrogenase activity, and could therefore be independent of dinitrogen fixation. These observations and other aspects of GS gene regulation are discussed in detail in context of the *in situ* hybridization and immunocytochemistry results in Chapter 5.

1.4.5. The Expression of Chimaeric Glutamine Synthetase Genes in Transgenic Plants.

The differential expression of the genes specifying the γ and β GS polypeptides of *P. vulgaris* has been demonstrated in transgenic *Lotus corniculatus* plants. Forde *et al.* (1989) demonstrated, that a fragment

of approximately 2 kb from the 5' flanking regions of the *gln-β*, and *gln-γ* genes fused to the bacterial β-glucuronidase (GUS) gene, resulted in the differential expression of GUS gene in transgenic *L. corniculatus* plants. The presence of the *P. vulgaris* GS flanking regions was therefore demonstrated to play a major role in controlling the expression of these GS genes in *P. vulgaris*.

Plant lines containing a *gln-β*/GUS and two different *gln-γ*/GUS gene fusions were demonstrated to express the GUS gene (Forde *et al.* 1989). The *gln-γ*/GUS fusions were; a transcriptional fusion (line B₁B₁) which contained 52 bp of the 5' flanking region of the *gln-γ* gene so that the translational codon was supplied by the first ATG codon of the GUS gene, and a translational fusion (lines J₁D₁ and C₁E₁) which contained an additional 44 bp of the 5' flanking region and the first 24 bp of the GS *gln-γ* coding sequence. Plants containing the *gln-β* constructs all contained the same translational fusions consisting of 1.7 kb of the *glnβ* 5' flanking region and the first 19 bases of the coding sequence. The spatial patterns of expression of these gene constructs in transgenic *L. corniculatus* plants have been further investigated in this work using *in situ* localization techniques

1.4.6. The Expression of GS in Root Nodules of Other Legume Species.

Genomic and mRNA sequences for GS have been reported for nine higher plant species in addition to those in *P. vulgaris*. A single form of nodule-specific GS holoenzyme has been detected in soybean nodules (McParland *et al.*, 1976). Sengupta-Gopalan *et al.* (1986), using a *P. vulgaris* GS probe, demonstrated that GS mRNA levels in soybean nodules

began to increase approximately 12 days after infection. Verma *et al.* (1986), demonstrated that an abundant form of GS was localised in the infected cells of soybean root nodules.

Two isoenzymic forms of GS have been detected in alfalfa root nodules, one of which is nodule-specific and is distinguishable from the other by its insensitivity to tabtoxinine-B-lactam *in vivo* (Knight and Langston-Unkefer, 1988). Groat and Schrader (1982) have reported up to 10 cytosolic forms of GS polypeptides in alfalfa.

Five distinct GS polypeptides have also been detected in peas (Tingey *et al.*, 1987), although all were present in both roots and nodules, and suggested that there was increased expression associated with nodulation, but no evidence of differential induction.

GS activity has also been demonstrated to increase significantly during the development of root nodules in lupin (Robertson *et al.*, 1975b), and evidence has been obtained in two lupin species for the existence of 'nodule-specific' GS genes (Konieczny *et al.*, 1988).

1.5. *IN SITU* LOCALISATION TECHNIQUES

Much of the information concerning the expression of GS in root nodules has been obtained from work using homogenized nodule tissue. One of the unique characteristics of the *Rhizobium*/legume symbiosis is however the development of specialized nodules, which represent a unique combination of infected and non-infected cells which apparently have very different metabolic functions. Homogenization techniques are unable to demonstrate any differential gene expression within these different cell types with any degree of clarity. *In situ* hybridization techniques allow these specific cellular differences to be highlighted and, in combination with immunocytochemistry, *in situ* hybridization can provide important insights into the control of gene expression at the mRNA and protein levels.

1.5.1. Hybridization to mRNA.

The first reports of successful *in situ* hybridizations, involving the use of DNA probes hybridized to mRNA in tissue sections, were made independently, by Gall and Pardue (1969) and John *et al.* (1969).

The technique of *in situ* hybridization provided a novel method of locating and examining the expression of mRNA in tissue. As the methods for DNA purification, probe preparation, and probe labelling progressed rapidly, the use of *in situ* hybridization on animal tissues increased in parallel. Techniques advanced to the use of cRNA probes in addition to the cDNA probes, and methods were also introduced for non-isotopic labelling of probes (Ward *et al.*, 1985; Bresser *et al.*, 1987)

The application of the technique to plant tissues and cells was

slower. Harris and Croy (1986), Mouras *et al.* (1987) and Smith *et al.* (1987) were some of the first to report *in situ* hybridizations on plant cells. More recently there have been further reports of the use of plant cell hybridizations using both radiolabelled cDNA (Meeks-Wagner *et al.* 1989), and cRNA (Comai *et al.* 1989) probes.

1.6. AIMS OF THIS RESEARCH.

This introduction has illustrated the value of nitrogen fixation by legumes, both as a commodity in itself, and as an ideal model in which to study the control of plant gene expression through the symbiotic plant-*Rhizobium* relationship. The role of GS in legume root nodules has been demonstrated to be one of major importance.

It has been established that genes specifying the three cytosolic GS polypeptides (*gln- α* , *gln- β* and *gln- γ*) are differentially expressed in developing nodules. Until now very few studies on the expression of the GS genes have been able to demonstrate the cellular location of the polypeptides.

Research has been carried out with the aims to;

1. describe the major morphological and ultrastructural factors of *P. vulgaris* root nodule development.
2. establish *in situ* hybridization techniques for *P. vulgaris* root nodule tissue by;
 - (i) optimizing fixation, embedding and sectioning methods.
 - (ii) preparing suitable cRNA probes,
 - (iii) investigating the non-isotopic, photo-biotin method of probe labelling
 - (iv) optimizing the *in situ* hybridization conditions as for *P. vulgaris* root nodule sections.
3. use this optimized *in situ* technique to demonstrate the differential temporal and spatial patterns of expression of the *gln- α* , *gln- β* and *gln- γ* genes.
4. demonstrate the cellular locations of GS isoenzymes in developing *P.*

- vulgaris* root nodules by immunocytochemistry.
5. investigate the expression of GS genes fusions with β -glucuronidase (GUS) in transgenic *Lotus corniculatus* plants by;
 - (i) *In situ* hybridization
 - (ii) immunocytochemistry
 - (iii) histochemical staining of GUS enzyme activity.
 6. compare results from 3, 4 and 5 and consider the of the differential temporo-spatial expression of the cytosolic GS genes in developing *P. vulgaris* root nodules.

MATERIALS AND METHODS

2. MATERIALS AND METHODS

2.1. TISSUE PREPARATION

2.1.1. Plant Growth Conditions.

2.1.1.1. For *Phaseolus vulgaris*.

Phaseolus vulgaris L. cv. tendergreen seeds obtained from Dr.B.Forde (Rothamsted Experimental Station), were washed for 1 minute (min) in 75% ethanol (with stirring) to remove the waxy coating from the seeds, sterilized in 4% sodium hypochlorite for 1-2 min, washed 5 times in distilled water and soaked for 30 min to 5 hours (h).

The sterilized seeds were sown in a 1:2 parts (autoclaved) sand:gravel mixture, with approximately 9 seeds per 10 inch pot. The pots were placed in a growth cabinet with a 12 h day, 28° daytime temperature and 25° nighttime temperature, at 8000 lux (200-300 μ Einsteins).

Pots were inoculated at the time of sowing and again at approximately four days after sowing, with *Rhizobium phaseoli* strain 3622. Rhizobia were cultured on a YM agar slope (1L agar contained; 0.5g K_2HPO_4 ; 2.0g $MgSO_4 \cdot 7H_2O$; 0.1 g NaCl; 10.0 g mannitol; 0.4 g yeast extract and 15 g agar), and were resuspended by the addition of sterile water to the slope when required. The cell suspension obtained was diluted to 50 ml, and each pot inoculated with 10 ml. The plants were watered with Reading nutrient solution (a modified Hoaglands solution) containing; $MgSO_4 \cdot 7H_2O$; K_2HPO_4 ; Ferric sodium EDTA; K_2SO_4 , made up in tap water which was assumed to contain sufficient micronutrients for

plant growth and nodule development.

Whole plants were harvested at 10, 14, 17, 21, 24 and 38 days after inoculation. After harvesting the roots were washed in distilled water, the smaller young nodules were cut off at the root to leave just the nodule, or were cut off with approximately 2 mm of root attached to the nodule. The larger nodules were cut off at the root and then cut in half, to allow better penetration of fixative and embedding material, in some cases very large nodules were cut into three parts.

2.1.1.2. For *Lotus corniculatus*

Transformed *Lotus corniculatus* plants cv. Leo obtained from Dr B Forde, were grown in Petri dishes (radial axis vertical) with the lower half blackened out. The plants were grown on agar slopes containing the constituents of Fahreus solution; A 10 x stock contained; 1 g $\text{CaCl}_2 \cdot 2\text{H}_2\text{O}$; 1.2 g $\text{MgSO}_4 \cdot 7\text{H}_2\text{O}$; 1 g KH_2PO_4 ; 1.5 g $\text{Na}_2\text{HPO}_4 \cdot 12\text{H}_2\text{O}$; 0.05 g ferric citrate. Plants were subcultured every 1-2 weeks, with the nodules removed and fixed; the remaining part of the plant was re-inoculated with *Rhizobium loti*, and grown at 25°, 50 $\mu\text{Einsteins m}^{-2} \text{sec}^{-1}$ on a 16 hour day.

2.1.2. Fixation.

Phaseolus vulgaris cv. tendergreen, plants were grown for 10-28 days before the nodules were harvested and fixed. Nodules were washed in distilled water, blotted dry and cut in fixative (usually in half). To find the best fixative for both cell and RNA preservation the following fixation methods were used.

Table 1. Tissue Fixation Conditions.

Fixative	time / temperature	1st wash
1. 70% EtOH/30% HOAc	20 min R.T.	70% EtOH
2. 95% EtOH/5% "	15 min "	95% "
3. 75% EtOH/25% HOAc	15 min "	75% "
4. 100% EtOH	48 h -80°C	100% EtOH
5. 70% EtOH/30% dH ₂ O	20 min 4°C	75% EtOH
6. 100% Methanol	20 min -20°C	70% EtOH 4°C
7. 100% Acetone	20 min -20°C	70% EtOH 4°C
8. 50% Acetone/50% methanol	20 min -20°C	50% EtOH 4°C
9. 4% para in PBS	20 min R.T.	PBS.
10. 4% para in PBS	20 min 4°C	PBS
11. 10% formald./90% methanol	20 min 4°C	PBS
12. 2.5% para. in PBS	30 min R.T.	PBS
13. 1% glut. in 0.05M cacodylate buffer.	3 h R.T.	Cac. Buffer.
14. 1% glut. in PBS	3 h R.T.	PBS.

para - paraformaldehyde, made up freshly each time. PBS-phosphate buffered saline, (0.15 M NaCl; 3 mM KCl; 8 mM Na₂HPO₄·12H₂O; 1 mM NaH₂PO₄; 0.01% Thermosol; 0.05% Tween 20, pH 7.2). Glut - glutaraldehyde, (TAAB lab. equipment). EtOH - absolute ethanol, HOAc - acetic acid.

A second set of fixations were carried out using the above conditions except the fixation time was increased to 15 hours followed

by a 1 hour wash.

For immunocytochemistry tissue was fixed for four hours in 2.5% glutaraldehyde and 1.5% paraformaldehyde in 0.05 M sodium cacodylate buffer, then washed overnight in the same buffer. For structural and ultrastructural studies tissue was fixed as for immunocytochemistry, and post-fixed with 1% osmium tetroxide for four hours.

2.1.3. Dehydration and Embedding

2.1.3.1. Dehydration

After fixation and washing, tissue was dehydrated starting at the appropriate alcohol dilution. The full alcohol series was 12.5%, 25%, 50%, 75%, 95%, and 100% dry alcohol, with a 2 x 15 min incubation in each concentration and 4 x 15 min in the 95 and 100% ethanol solutions.

2.1.3.2. Embedding

For *in situ* hybridization tissue was infiltrated over 4-6 days at 37°C with PEG 1000 (polyethylene glycol M_w 1000 obtained from BDH). After 2-3 changes of 100% PEG, tissue was placed in plastic embedding capsules (TAAB), with molten PEG, then placed on ice to set. Embedded material was stored at 4°C until required.

For immunocytochemistry tissue was infiltrated with L.R. White (London Resin Co.), over 2-3 days, after 2-3 changes of fresh resin, tissue was placed in plastic embedding capsules with fresh resin, covered to exclude any air, and polymerized at 70°C overnight. Tissue for structural and ultrastructural studies was embedded in Spurr resin (TAAB), using the same procedure as for L.R. White embedding, although capsules were not covered during polymerization.

2.1.4. Sectioning and staining for RNA.

10 μ m PEG sections were cut with a steel knife, using a Leitz 1512 microtome; they were dried down on subbed slides (washed slides were subbed with a 0.2% gelatine (BDH), 0.02% chrome alum solution, Aldrich chemical Co.) and stained with acridine orange (Sigma) and methyl green pyronin, to assess the relative RNA content of the tissue after the different fixation conditions.

Staining protocols were as follows:

Acridine orange staining; sections were stained (in 0.5 mg/ml acridine orange made up in 0.2 M glycine-HCl pH2.0) for 30 min in the dark then washed for 2 x 15 min in 0.2 M glycine, mounted in Ciftifluor (Agar Aids), and examined under a Nikon fluorescence microscope using a blue excitation filter.

Methyl green pyronin staining: Sections were washed in 0.2 M sodium phosphate buffer pH 6.0, washed in water for 5 min, then in Walpole's buffer pH 4.8 (60 parts 0.2 M sodium acetate; 40 parts 0.2 M acetic acid), and then stained in methyl green pyronin, (9 parts-2% aq. methyl green; 4-parts 2% aq. pyronin; 14-parts glycerol; 23-parts Walpole's buffer pH 4.8.) for 25 minutes. After staining the sections were briefly washed in Walpole's buffer, blotted dry, and taken through 1:1 acetone:Histosol (Agar Aids), Histosol, and mounted in Histamount. Control sections were incubated in the above phosphate buffer for 1 hour at 37°C, further control sections were incubated under similar conditions with 0.5 mg/ml RNase A (Sigma) in phosphate buffer. Slides were examined under bright field illumination for the presence of RNA shown by the degree of pink staining.

Sections stained with both acridine orange and methyl green

pyronin were scored on a scale of 1-10 for the staining of RNA as shown up by the 2 stains, and for the tissue preservation for each particular fixative.

2.2. PROBE PREPARATION AND LABELLING

2.2.1. Preparation, Labelling and Testing of cDNA Probes

2.2.1.1. Preparation of Glutamine Synthetase cDNA probes

A 140 bp *HindIII/BglIII* fragment was excised from the 5' flanking region of the *gln-β* cDNA clone, and a 250 bp *RsaI/PstI* fragment from *gln-γ* cDNA. After the digests the DNA was electrophoresed overnight on an upright 6% acrylamide gel.

The excised fragments were then electroeluted from the gel as follows:

The gel was stained in 500 ml elution buffer (0.5 M Tris; 0.25 M Acetic acid, pH 8.0), containing 100 μ l (10 mg/ml) ethidium bromide for 30 minutes, then washed in 500 ml of the same buffer for 15 min. The appropriate inserts were cut out of the stained gel under ultra violet light, and placed in a siliconized, (11 mm diam.), glass tube containing 1 ml elution buffer. The gel slice was transferred to pre-washed* dialysis tubing (size 2-18/32) and tied at both ends excluding air bubbles as far as possible.

*Dialysis tubing was washed by boiling in 1 litre 2% NaHCO₃, 1 mM EDTA for 10 min, rinsed in distilled water, then boiled for a further 10 minutes in 0.1 mM EDTA, then stored at 4°C in 50% ethanol, 50% 1 mM EDTA.

The dialysis tubing containing the gel fragments was partially covered with elution buffer in a baby gel tray, and eluted at 210 V (15 V/cm) for 1-2 h. The current was reversed for 1 min at the end of the electroelution to remove any DNA stuck to the tubing. The buffer was then transferred from the tubing to 2 Eppendorf tubes and ethanol

precipitated by adding 1/20th the total volume 4 M ammonium acetate, followed by 2.5 volumes of ethanol, and left at -20°C overnight. The following day the tubes were spun for 15 min at 4°C, the supernatant drained off, and the pellet washed in 75% ethanol, spun for 5 minutes, drained and vacuum desiccated. The final pellet was dissolved in 10 mM Tris-HCl pH 8.0; 0.1 mM EDTA. (TLE).

2.2.1.2. Photo-Biotin Labelling of Probes

A Photoactive biotin was obtained from Vector Laboratories and was initially tested on pUC9 plasmid DNA. An equal volume of Vector Laboratories 'Photoprobe' was mixed with 5 µl (0.25 µg) cDNA probe in sterile distilled water (SDW) under safe light illumination. The mixture was then irradiated for 40 min, using a mercury tungsten 500 W lamp, with the sample 15 cm below the lamp and maintained on ice with the top of the tube open.

The labelled probe was purified as follows; the probe + biotin was made up to 100 µl with 0.1 M Tris-HCl pH 9.5, then 100 µl Butan-2-ol was added, the solution was mixed, spun for 2 min to separate the 2 layers, the upper layer discarded, a further 100 µl butan-2-ol was added, mixed, spun and the upper layer discarded, the remaining solution was ethanol precipitated (as outlined following the electroelution of DNA fragments). The resultant pellet was resuspended in 10 mM Tris-HCl, 1 mM EDTA and stored at -20°C until required.

2.2.1.3. Biotin Detection.

A Biotin detection kit (BRL) was used to determine the level of biotin incorporation into the plasmid DNA, in comparison with supplied

biotinylated DNA standards.

The standard protocol as suggested in the kit was followed using alkaline phosphatase and substrates:

Detection strips; 0-1 ng of biotinylated DNA was dotted onto nitrocellulose strips in 5 μ l aliquots (biotinylated DNA was diluted to the appropriate concentrations with 5 x SSC, diluted from a stock of 20 x SSC; 3.0 M sodium chloride; 0.3 M sodium citrate, pH 7.0). Filters were dried in a vacuum oven for 1-2 h at 80°C.

Alkaline Phosphatase Detection; filters were rehydrated for 1 min in buffer 1 (0.1 M Tris-HCl pH 7.5; 0.1 M NaCl; 2 mM MgCl₂; 0.05% (v/v) Triton X-100), then incubated for 20 min at 42°C in buffer 2, (3% (w/v) bovine serum albumin, (Sigma), in buffer 1). Filter strips were then blotted dry and dried in a vacuum oven for 10-20 minutes at 80°C.

Filters were rehydrated in buffer 2 for 10 min 1 ml 2 μ g/ml BRL streptavidin in buffer 1 was then applied to the filter strips and incubated at room temperature for 10 min, in a sealed bag. The strips were washed for 3 x 3 minutes in a large volume of buffer 1, followed by a 10 min incubation in 1 μ g/ml biotinylated calf intestinal alkaline phosphatase (Biotin AP). The filter strips were washed in buffer 1 for 2 x 3 minutes, then buffer 3, (0.1 M Tris-HCl pH9.5; 0.1 M NaCl; 50 mM MgCl₂), for 2 x 3 minutes, followed by incubation in the BRL dye solution which was prepared by adding, 3.3 μ l NBT (nitro-blue tetrazolium, 75 mg/ml in 70% dimethylformamide), and 2.5 μ l BCIP (5-bromo-4-chloro-3-indolyl phosphate, 50 mg/ml in dimethylformamide), to 750 μ l buffer 3. The filter strips were incubated in the dark for 1-4 h.

2.2.1.4. Hybridization of cDNA Probes on Filters.

Preparation of filters; pBR322 plasmids containing α , β and γ (R-2, R-1 and N-1) probe sequences (as illustrated in section 2.2.2), were linearised with *EcoRI*. The linearised plasmids were denatured (by placing in a boiling waterbath for 5 min.), and transferred onto a 'Biodyne' filter which had been moistened in 2 X SSC, using a Biorad 'dot blot' apparatus. The filter was then subjected to the following; 1 X 5 min in denaturation solution, 1 X 5 min in 1 M Tris-HCl pH 8.0 and 1 X 5 min in 1.5 M NaCl, air dried, and then baked at 80°C for 2 h.

Hybridization conditions; biotin labelled GS probes were hybridized to linearized plasmid DNA containing the target inserts fixed on nylon 'Biodyne' filters.

The following hybridization conditions were used; pre-hybridization solution; 5 X Denhardt's (diluted from a 50 x stock of, 1% ficoll 400, 1% polyvinyl-pyrrolidone, 1% Bovine Serum albumin) solution, 5 X SSC, (diluted from a solution of 20 x SSC, 3 M sodium chloride, 0.3 M sodium citrate), 0.5% SDS (from a stock of 10% sodium dodecyl sulphate), 100 μ g/ml denatured herring sperm DNA, 45% deionized formamide, 25 mM sodium phosphate and 5% dextran sulphate (Sigma). Filters were incubated for 2 h at 42°C. The denatured, biotin labelled probe was then added and the filter incubated overnight at 42°C.

Washes were carried out as follows; 2 X SSC, 0.1% SDS, 2 X 15 min at room temperature, 0.2 X SSC, 0.1% SDS, 2 X 15mins at room temperature, 0.1 X SSC, 0.1% SDS, 1 X 15 min at 65°C, followed by a rinse in 2 X SSC.

Further hybridization tests were carried out using a range of plasmid concentrations. The linearized plasmid was fixed to the nylon

filter using a hand held ultra violet light rather than baking at 50°C for 2 hrs. This was demonstrated by Khandjian (1987) to be an improved method for fixing DNA to nylon filters.

2.2.2..Construction of cRNA Probes

2.2.2.1 Preparation of inserts

The restriction maps in Figure 1 show the location of the inserts used to construct cRNA probes.

Figure 1. Diagram to show the location of the probes used for the *in situ* hybridizations.



(i). γ probe, a *RsaI/PstI* fragment from the 5' flanking region.

(ii). Two β probes;

a *HindIII/BglIII* fragment from the 5' flanking region,

and a *FokI/BamHI* fragment from the 3' flanking region.

(iii). α probe, a *BglIII/EcoRI* fragment from the 5' flanking region.

Fragments were excised from cDNA clones with the appropriate restriction enzymes. The *FokI* digest for the β probe left sticky ends which required filling in with Klenow fragment of DNA polymerase I prior to the second *BamHI* digest. The Klenow treatment was carried out

as follows: the previous digest was heat inactivated for 10 min at 65°C, then 11 µl 1 mM dNTP was added and mixed, followed by 5 U Klenow and a 15 min incubation at room temperature. The reaction was stopped by the addition of 2 µl 0.5 M EDTA, followed by 10 min at 55°C to heat inactivate the enzyme, and the digest transferred to ice immediately. After propanol precipitation, of the DNA, the second restriction was carried out.

The α and 5' β probes were electroeluted from a 1.2% agarose gel (as outlined in 2.2.1.1). The 3' β probe was electroeluted from a 6% acrylamide gel.

2.2.2.2. Preparation of the Plasmid Vector.

The 'Bluscribe' (pBS) vector used, was obtained from Stratagene and contained T3 and T7 promoters flanking the cloning sites.

The following digests were carried out on 1.2 µg vector DNA for each insert;

Table 2. Vector digests for subcloned cDNA fragments.

INSERTS	VECTOR Digested with	promoter	linearised with;
α	<i>EcoRI/BamHI</i>	T3	Eco RI
3' β	<i>SmaI/BamHI</i>	T3	EcoRI
5' β	<i>HindIII/BamHI</i>	T7	Hnd III
γ	<i>SmaI/PstI</i>	T3	Eco RI

The promoters listed above produce the probe or antisense complementary probes for *in situ* hybridization.

Ligation of probe fragments to vector DNA. A target ligation consisting of the vector + probe and a self ligation of vector alone

were carried out for each fragment.

The ligations were carried out in the following solutions;
Target ligations, 1 μ l cut vector DNA (25 ng), 1 μ l (5 ng) insert DNA, 1 U (BRL) T4 DNA ligase, 1 μ l 5 X ligation cocktail, made up to 5 μ l with sterile distilled water. Self ligations were the same as the target but without the insert DNA. Incubations were carried out at 14°C overnight. The following morning the reaction was stopped by adding 44 μ l T.E. buffer and 1 μ l 0.5 M EDTA and the solution stored at -20°C until required.

2.2.2 3. Preparation of Competent Cells and Transformation.

Frozen and fresh competent cells were prepared from JM101 and JM83 cell lines bacterial cell lines using the following methods.

Preparation of frozen competent cells; An overnight culture of 25 ml 2 XL broth + glucose (20 g bactotryptone, 10 g yeast extract, 1 g NaCl, dissolved in 1:1 H₂O, adjusted to pH 7.0 if necessary, and autoclaved. 1 % (v/v) 20% filter sterilised glucose was added before use) in a 250 ml conical flask, was inoculated with a single colony of JM101 or JM83 and shaken overnight at 30°C. 100 ml 2 XL broth pre-warmed to 30°C in a 500 ml conical flask was inoculated with 1 ml of the O/N culture, and incubated at 30°C for approximately 1 h. until the OD₆₀₀=0.25. (1ml was removed from the culture at intervals and the OD₆₀₀ read, (the OD₆₀₀ of 0.25 took approximately 35 min to be reached)). At this stage 1 ml 2 M MgCl₂ was added and the culture grown at 30°C (shaking) to an OD₆₀₀=0.45-0.55. The cells were quickly cooled on ice/water, and left on ice for 2 h, (in some cases cells left O/N have shown considerably higher levels of competence).

Cells were pelleted in sterile 40 ml (plastic) tubes at 5000 rpm for 5 min at 4°C, and the supernatant discarded. Cells were again gently resuspended in half the growth volume, 12.5 ml, ice cold Ca²⁺/Mn²⁺ solution (Ca²⁺/Mn²⁺; for 50 ml, 40 mM-0.27 g sodium acetate, 100mM-1.10g CaCl₂ · 4H₂O, 70mM-0.69 g MnCl₂ · 4H₂O, pH adjusted to 5.5 with HCl, and the solution filter sterilised through a 22 µm filter and cooled on ice, made up freshly). Cells were incubated on ice for 1-2h, then spun at 3000 rpm for 5 min at 4°C, (good competent cells should form a doughnut shaped pellet). Cells were gently resuspended in 1/20th the initial growth volume (2.5 ml/tube.), in Ca²⁺/Mn²⁺ solution containing 15% glycerol. 0.3 ml aliquots were transferred into 1.5 ml Eppendorf tubes and frozen immediately in liquid nitrogen, then stored at -80°C.

The preparation of fresh competent cells; 100ml of 2 X YT media was inoculated with JM101 or JM83 and incubated overnight at 37°C without shaking. 25 ml of pre-warmed 2 X YT broth in a conical flask was inoculated with 0.5 ml of resuspended O/N culture, and incubated 1-1.5 h. with shaking, until the OD₆₀₀ was 0.3-0.4. Cells were pelleted in a Beckman SS34 rotor at 5000 rpm for 4-5 min at 4°C. The supernatant was poured off and the cells gently resuspended in 1/2 the growth volume (12.5 ml) 50 mM ice-cold calcium chloride and left on ice for 20 min. Cells were re-pelleted and gently resuspended in 1/10th the growth volume (2.5 ml) ice-cold 50 mM calcium chloride solution, then used in the transformation.

Transformation: An initial transformation was carried out on cut and uncut vector to test the competence of cells. DNA was diluted to the required concentrations;

(i). Uncut vector to a concentration of 10 pg/25µl in TE buffer.

(ii). Cut vector to a concentration of 1 ng/25µl.

50 µl aliquots of competent cells were added to the 25 µl diluted DNA at 4°C (on ice in 1.5 ml Eppendorf tubes).

The cells + DNA were left on ice for 30 min. 1.5 ml 2 XL broth + glucose was warmed to 37°C in sterile (metal capped) glass tubes. Cells were heat shocked at 37°C for 5 min, then added to the pre-warmed 2XL broth + glucose, shaken for 90 min at 37°C. (an appropriate time for pouring plates). 10mls bottom agar was melted and kept at 54°C, (1 ml per transfection). After the 90 min incubation was complete, 1 ml of bottom agar was mixed with each 1.5 ml culture in a 42°C water bath. 50 µl 2% X-gal in dimethyl formamide, 10 µl 100 mM IPTG (24 mg/ml in sterile distilled water) and 7.5 µl 20 mg/ml ampicillin were quickly added and poured onto L-agar plates containing 100 µg/ml ampicillin. Plates were incubated O/N at 37°C and the colonies counted the following day.

2.2.3.4. Screening Transformants by Colony Hybridization and Southern Blotting.

Preparation of immobilized colonies on filters: Twenty small white colonies (suspected transformants), were transferred to an L-agar master plate and to Schleicher and Schnell 82 mm 0.45 µm pore size 3.1 mm grid on a second L-agar plate. The plates were incubated at 37°C

overnight, then stored at 4°C until required. The grids were then used for the colony hybridizations in order to identify the colonies containing the correct GS fragments.

Filter hybridizations: Preparation of filters; grids on which transformed colonies had been grown were removed from the L-agar plates and transferred to a series of Petri-dish lids containing filter paper soaked in the following; 0.5 M NaOH; 1 M Tris-HCl; pH 7.5, 2 X 5 min, 1.5 M NaCl; 0.5 M Tris-HCl pH 7.5, 1 X 5 min. Grids were allowed to air dry, then baked at 80°C for 2 hours under vacuum.

Preparation of probes; the 4 cDNA fragments corresponding to those subcloned in to the pBS vector were pooled, and ³²P-labelled using the Amersham nick translation kit to use for hybridization to the immunomobilized colonies. The pooled fragments were incubated in; 2 µl d-GTP:dCTP:dTTP, 1:1:1, nucleotide buffer; 250 ng pooled cDNA probe in 5 µl TLE buffer, 2 µl sterile distilled water, 1 µl nick translation enzyme, DNA polymerase, [³²P] dATP (3000 Ci/m mole), at 15°C for 2 h. Following the 2 h incubation the nick translation solution was passed over a 2.8 ml Sephadex G50 column and 100 µl fractions were collected. The fractions containing the labelled cDNA were combined and frozen at -20°C until required for the colony hybridizations.

Filter Hybridizations: The Hybaid I blot processing system (Hybaid Ltd.) was used for pre-hybridizing, hybridizing and washing the nitrocellulose filters. The filters were sealed in a 137 mm x 210 mm bag and pre-hybridized minimum of 2 hours at 65°C in the following solution (Grunstein and Hogness, 1975). 2 ml 100 X Denhardt's solution, 0.1 ml 20% SDS, 2 ml 20 X SSC, 200 µl freshly boiled herring sperm DNA (10 mg/ml), 16.7 µl SDW (sterile distilled water). Following the

prehybridization, the combined labelled probe was added and the filters hybridized at 65°C with shaking overnight. Hybridized filters were washed in 1 l, 2 X SSC, 0.1% SDS, and autoradiographed overnight.

The alkaline lysis (Section 2.2.2.5) method was used to prepare plasmid DNA from clones which appeared to have hybridized to the probe in the colony hybridizations.

Southern Blotting: GS cDNA fragments were used to identify the correct inserts in the pBS vector by southern blotting:

- (i). *Hind*III/*Bam*HI digest of the pR-1 cDNA clone to generate a 2.7 kb plasmid fragment, a 1100 bp 3' fragment and a 350 bp 5' fragment to identify the β fragments.
- (ii). *Hind*III/*Bam*HI digest of the pR-2 cDNA clone to generate a 2.7 kb, a 50 bp and a 70 bp fragment, a single *Bam*HI digest was also used to help identify the correct α fragments due to the large number of *Hind*III restriction sites..
- (iii). *Pst*I digest of the pN-1 cDNA clone, to provide, a 4.3 kb plasmid fragment and a 700 kb insert, to identify the γ fragments.

The resultant fragments were electrophoresed on a 1.2% agarose gel.

Blotting: The gel was washed in distilled water, then incubated for 1 X 20 minutes in 1 l denaturation solution (0.5 M NaOH; 1.5 M NaCl), followed by a further, 1 X 40 min in 1 l of the same solution, then rinsed in distilled water followed by 1 X 60 min in 1 l neutralization solution (1 M Tris-HCl; 3 M NaCl, pH 5.5). The top and sides of the gel were trimmed off, and a wick of Whatman 3 MM paper was soaked in 20 X SSC (3 M NaCl, 0.3 M sodium citrate) and the gel

laid on top of the wick. A Biodyne filter, a fraction larger than the gel was laid on top of the gel, followed by two pieces of Whatman 3 MM paper, absorbant pads were placed on top of the Whatman paper with a glass tray and a small weight on the top. Strips of discarded X-ray film were placed around the edges of the gel to prevent short circuits. The blot was then checked for any leaks and short circuits, and left for 36 h, changing the pads if required.

After blotting the pads were removed, and the filter allowed to air dry on filter paper, then baked at 80°C. The gel was stained in ethidium bromide to check that the DNA had been successfully transferred.

The putative GS subclones were excised from the vector DNA, ³²P-labelled and hybridized individually to the blots, using the filter hybridization conditions outlined earlier in this Section.

2 2.2.5. Preparation of plasmid DNA.

Several methods of preparing plasmid DNA were used to bulk up specific plasmids containing inserts which hybridized to the correct GS cDNA fragments.

Small scale plasmid prep by alkaline lysis and PEG precipitation: A 10 ml culture in L-broth medium containing 100 µg/ml ampicillin was shaken overnight at 37°C. Cells were collected by centrifugation at 4000 rpm for 10 min and resuspended in 100 µl 25 mM Tris-HCl pH 8.0/10 mM EDTA/50 mM glucose, (solution I), then transferred to Eppendorf tubes. 20 µl lysozyme (20 mg/ml in solution I) was added to each Eppendorf, mixed and left to incubate on ice for 20 min 200 µl 0.2 M NaOH/1% SDS (solution II), was added, mixed and incubated on ice for a

further 20 min, 150 μ l 3 M NaOAc pH 5.2 (solution III), was added, mixed and incubated for 20 min. The cells were spun for 15 min at 4°C, the supernatant was decanted off into fresh tubes, 5 μ l boiled RNase A (10 mg/ml) was added, mixed and incubated at 37°C for 20 min. Cell protein was extracted with 300 μ l phenol/chloroform/isoamylalcohol, (25:24:1), the top phase decanted to a fresh tube, 1 ml ethanol added and left at -20°C overnight or -80°C for 1 hour and the nucleic acid collected by centrifugation. The resultant pellet was dried under vacuum, dissolved in 168 μ l distilled water. 32 μ l 5 M NaCl; 200 μ l 13% PEG (M, 8000), was added, mixed and left on ice for 1 h. The plasmid DNA was spun for 30 min, the pellet washed in 1 ml 70% ethanol, dried under vacuum and redissolved in 50 μ l TE buffer. An aliquot was run on an agarose baby gel with a known quantity of marker, to estimate the quantity of plasmid produced.

Midi plasmid prep by alkaline lysis and PEG precipitation: 4 X 1 l, conical flasks containing 250 ml L-broth with 100 μ g/ml ampicillin were inoculated and shaken overnight at 37°C. Cells were spun down the following morning at 3000 rpm 4°C for 15 min., the pellets resuspended in 24 ml solution I (25 mM Tris-HCl, pH 7.5; 10 mM EDTA; 15% sucrose; 2 mg/ml lysozyme, freshly prepared and chilled on ice), and divided between 4, 30 ml corex tubes. The resuspended cells were incubated on ice/water for 20 min. 48 ml solution II, (0.2 M NaOH; 1% SDS), was added (12 ml/4 tubes), the solution carefully mixed, and incubated for a further 10-20 min. on ice/water. 30 ml solution III, (3 M NaOAc pH 5.2), was added, (7.5 ml to each of the 4 tubes). The cells were mixed carefully by inversion and incubated for 20 min on ice/water, then spun at 12000 rpm for 20 min. The supernatant was decanted into 4 corex

tubes avoiding the white precipitate, 200 μ l RNase A (10 mg/ml), 50 μ l/tube, was added and incubated for 20 min. at 37°C. Two phenol/chloroform extractions were carried out, then twice the final volume of ethanol was added to precipitate the DNA, then left at -80°C for 1 h or -20°C overnight. The DNA was precipitated by spinning at 10000 rpm for 20 min, the pellet washed in 75% ethanol, drained and dried down. The dried down pellet was resuspended in 5.12 ml (1.28 ml/tube) SDW, then 1.28 ml 4 M NaCl was added and mixed (320 μ l/tube), followed by 6.40 ml 13% PEG (1.6 ml/tube), mixed and incubated on ice/water for 60 min. The DNA was spun down at 10000 rpm for 10 min, the supernatant removed, the pellet washed in 75% ethanol, (spun at 10000 rpm for 5 min) drained and dried down, then resuspended in TE buffer (1 l, culture should provide approximately 8 mg plasmid DNA). The resuspended DNA was transferred to Eppendorf tubes, and the concentration estimated by running on an agarose gel against a quantified marker.

Alternative method for Midi-plasmid prep. (Holmes and Quigley, (1981), modified). A 50 ml culture was estimated to yield approximately 30-40 μ g plasmid DNA: A single colony was used to inoculate 10 ml L-broth + ampicillin (100 μ g/ml) in a 50 ml centrifuge tube and shaken overnight at 37°C. Cells were then spun down at 7000 rpm for 5 min. at 4°C, the supernatant poured off and the pellets allowed to drain almost dry. Pelleted cells were made into a paste in the remaining liquid and taken up in 0.7 ml STET (0.8 g sucrose; 5 ml 10% Triton; 1ml 0.5 M EDTA; 0.5 ml 1 M Tris HCl pH 8.0, made up to 10 ml with SDW and cooled on ice), per 10 ml original volume. 50 μ l lysozyme (10 mg/ml) was added and mixed gently but thoroughly, then transferred to an

Eppendorf tube. The tube(s) were then placed in a boiling water bath for 40 sec, then spun immediately for 10 min at room temperature. The resultant pellets were removed with a toothpick and discarded (only a small volume was left, approximately 500-500 μ l). 0.5 volumes 4M NH_4OAc and 2 X the original volume isopropanol (propan-2-ol) were added, the solution mixed and left at room temperature for 10 min., then spun for 10 min. at room temperature, the pellet washed in 1 ml 75% ethanol, spun for 5 min. at room temperature, drained and the pellet dried. The pellet was then resuspended in 200 μ l TE (10 mM Tris pH 8.0, 1 mM EDTA pH 8.1). 20 μ l RNase (10 mg/ml) was added and incubated for 2 hours at 37°C. The solution was extracted with phenol/chloroform twice, followed by two chloroform extractions then the plasmid was ethanol precipitated, resuspended and quantified on an agarose gel as for the previous plasmid preps.

Once a reasonable yield of plasmid had been obtained using one or more of the plasmid preps outlined above, the subcloned inserts excised from the plasmid using the appropriate restriction enzymes, and separated out on an acrylamide gel against the correct GS fragments to check their size. Further plasmid DNA containing the required inserts was then prepared using a caesium chloride plasmid prep.

Large scale isolation and purification of plasmid DNA-Caesium chloride plasmid prep: 10 ml L-broth (containing 25 μ g/ml ampicillin) was inoculated with a single colony containing the required insert and shaken overnight at 37°C. 200 ml L-broth (including antibiotic) was inoculated with 2 ml of the overnight culture in a 1 l, conical flask, and shaken for 3-4 h at 37°C until OD_{600} was approximately 1. The cells were collected by spinning at 7000 rpm for 10 min. at 4°C, the

supernatant poured off and the centrifuge tubes placed on ice. The pellet was made into a paste in the remaining liquid, then resuspended in 3 ml 25% (w/w) sucrose in 50 mM Tris HCl pH 8.0. The suspension was then transferred to SS-34 centrifuge tubes. 1 ml lysozyme, (10 mg/ml freshly prepared), was added to the suspension and swirled gently. The suspension was then left on ice for 5 min. swirling gently occasionally. 1 ml iced 0.5 M EDTA pH 8.1 was added and the suspension left on ice for a further 5 min. 9.5 ml iced Triton solution (1 ml 10% Triton; 12.5 ml 0.5 M EDTA; 5 ml 1 M Tris-HCl pH 8.0; 80 ml SDW, cooled on ice.), was added and mixed immediately by inverting the tube several times, then left on ice for 10 min. The lysate was spun at 18 000 rpm (or 12000 rpm, depending on the tubes), for 60 min. at 4°C.

The supernatant was poured off into a pre-weighed centrifuge tube (suitable for a Beckman type 42.1 rotor). The supernatant was weighed and an equal weight of CsCl was added and dissolved. The tubes were then filled up and balanced (including the lids) using 50% (W/W) CsCl in TE buffer. 900 µl ethidium bromide was added, the tubes balanced with paraffin oil and wrapped in foil. (Care was taken not to shake the tubes and to keep them in the dark, in order to avoid the effect of ethidium bromide in the light which can rapidly damage the plasmid DNA. Tubes were spun at 38 000 rpm at 15°C in a (pre-cooled Ti-70 rotor) at 15°C for 48 h. Tubes were covered with foil to protect them from the light when removed from the centrifuge. The gradients were viewed with ultra violet light, and the lower (red) band removed using a bent pasteur pipette. The band was transferred to a clean centrifuge tube, the tube filled up with 50% caesium chloride, balanced, then topped up with liquid paraffin, balanced and spun for 19 hours. The lower band

was removed as before, the ethidium bromide extracted from the recovered plasmid using butanol (pre-saturated with 20 mM Tris-HCl pH 8.0; 1 mM EDTA). An equal volume of butanol to plasmid/ethidium bromide was added, mixed, allowed to separate and the upper layer removed. This was repeated several times until the upper phase was clear. The plasmid was dialysed at 4°C for 1 hour against 2 X 1 l 10 mM Tris-HCl pH 8.0; 1 mM EDTA using pre-washed dialysis tubing (washing was carried out in 50% ethanol, then boiled in 10 mM NaHCO₃ + 1 mM EDTA followed by rinsing in SDW and stored in 50% EtOH). 1/20th volume 4 M NH₄OAc + 2.5 volumes ethanol was added to the contents of the dialysis tubing (in sterile corex tubes), and left overnight at -20°C. The DNA was spun down at 12 000 rpm for 20 min at 4°C, the supernatant removed and the pellet washed in with 75% ethanol, spun, then drained, dried down in a vacuum dessicator and re-suspended in TE buffer. The plasmid was quantified on a spectrophotometer.

2.3. THE USE OF RNA PROBES.

2.3.1. Transcription of Probes.

The pBS 'Bluescribe' plasmid vector (Stratagene), containing the required GS cDNA fragments for *in situ* hybridization probes, was linearized using a restriction digest to cut the plasmid at the end of the insert (to terminate the transcription continuing along the plasmid). The cut plasmid was phenol extracted, ethanol precipitated, washed in 75% ethanol, dried and resuspended in TLE buffer (10 mM Tris-HCl pH 7.5 + 0.1 mM EDTA).

Probes were transcribed according to the transcription protocol supplied by 'Stratagene': the transcription medium was set up as follows; 13.5 μ l DEPC treated distilled water, 5 μ l 5 X transcription buffer (5 x transcription buffer; 200 mM Tris-HCl pH 8.0; 40 mM MgCl₂; 10 mM spermidine; 250 mM NaCl; 1 μ g (1 μ l) DNA template; 1 μ l 10 mM rATP; 1 μ l 10 mM rGTP; 1 μ l 10 mM rUTP; 1 μ l 0.75 M DTT; 1 μ l 10 mM rCTP; 10 U T3 polymerase (or T7 polymerase), the solution was incubated at 37°C for 30 min. The solution was then made up to 250 μ l with DNase buffer, (40 mM Tris-HCl; 6 mM MgCl₂; 10 mM NaCl; 40 μ l 1 M Tris-HCl pH 7.5; 0.5 mg NaCl; 0.78 mg MgCl₂, made up in 960 μ l *DEPC treated water). 1 U RNase free DNase was added and the solution incubated at 37°C for 15 minutes. After incubation the solution was extracted with phenol/chloroform twice, followed by two chloroform extractions. The RNA was then ethanol precipitated by adding 1/10th volume Sodium acetate + 2.5 volumes ethanol, precipitated overnight at -20°C, spun down the following day, and washed in 75% ethanol. The pellet was dried and re-suspended in TE buffer (made up in *DEPC treated water).

An aliquot of the RNA was run on a 1.2% agarose baby gel to check all the plasmid DNA had been digested. The remaining RNA was quantified on a spectrophotometer and stored at -80°C until required.

*DEPC treated water was prepared from a 0.1% solution of DEPC in distilled water which was shaken, left for 15 min at room temperature, then autoclaved for 20 min.

2.3.2. Labelling and Testing of RNA Probes on Filters

2.3.2.1. Photo-Biotin Labelling of RNA Probes

Probe to be labelled was precipitated, resuspended in 1-2 µl distilled water or 0.1 mM EDTA and an equal volume of Photo-Biotin (Vector Laboratories) added under safe light illumination. The probe was irradiated 15 cm below a 500 W mercury vapour lamp in an open Eppendorf tube on ice. The probe was then made up to 100 µl with 0.1 M Tris-HCL pH 9.0, purified with an equal volume of Butanol-2-ol, the top layer removed, and extracted again with butanol, then ethanol precipitated.

2.3.2.2. Biotin Detection Strips and Dot Blots.

Nitrocellulose strips 1 cm x 5 cm were divided into 1 cm squares and spotted with 5 µl solution containing 0, 5, 10, 20 and 50 pg of BRL biotinylated standard DNA. Similar strips were made with the biotinylated RNA probes using 0, 10, 100 and 1000pg per 5µl. Strips were allowed to air dry, then baked at 80°C for 1-2 h under vacuum. The BRL biotin detection kit was used to detect the RNA as outlined in Section 2.2.1.2.

Probes labelled with 11-dUTP biotin incorporated in the

transcription were compared with the photo-biotin method using the biotin detection strips.

Amplification of the biotin signal was investigated on detection strips; amplification consisted of incubating filters with rabbit anti-biotin IgG (diluted 1/100 in PBS; 0.05 M phosphate, 0.7 M NaCl), for 20 min after the initial blocking step (see Section 2.2.1.2.), washed 2 x 5 min. in PBS, followed by a further 20 min. in anti-rabbit biotin for 20 min., washed in PBS, followed by BRL buffer 1, then incubated with the BRL streptavidin, biotin (AP), and the BRL dye solution as outlined in Section 2.2.1.2.

Alternative detection methods were also investigated using a colloidal gold secondary anti-body; anti-rabbit biotin IgG was replaced with anti-rabbit gold IgG, which was then silver enhanced. Experiments with and without salmon sperm DNA added to the biotinylated probe during the ethanol precipitation were carried out to check that this had no effect on the levels of background on filters.

2.3.3. *In situ* Hybridization

A variety of conditions and techniques were investigated in order to find a reliable and repeatable method for optimum hybridizations. The following *in situ* hybridization protocol, based on the methods used by: Bresser (1987), Cox *et al.* (1986) and Goldberg (1986) was used.

2.3.3.1. Pretreatments

10 µm nodule sections were dried on to subbed slides (as described in 2.1.4). Sections were washed in DEPC treated sterile distilled water to remove any remaining PEG, then incubated in 0.2 M HCl for 20 min. at

room temperature, washed in distilled water, incubated in 2 x SSC at 70°C for 15 min., washed in distilled water, blotted dry then incubated in 1 µg/ml proteinase K in TE buffer at 37°C for 30 min. Sections were blotted dry, fixed in 4% paraformaldehyde in PBS for 15 min, washed in PBS solution, and dehydrated, 1 x 2 min 25% ethanol, 1 x 2 minutes 50% ethanol, 1 x 5 minutes 75% ethanol, 1 x 2 minutes 100% ethanol, then air dried ready for the hybridization.

2.3.3.2. Hybridization

Photo-biotinylated cRNA, or cDNA probes were transcribed, labelled and tested as described in Section 2.3.2. 20 µl of the following hybridization solution was applied to the pretreated nodule sections on each slide; 8 ng biotinylated probe, 45% de-ionized formamide, 5 x Denhardt's solution (1% Ficoll 400, 1% polyvinyl-pyrrolidone, 1% B.S.A. dissolved in 500 ml provides a 50 x stock solution), 5 mg/ml yeast tRNA, 10 mM Tris-HCl pH 7.5, 1 mM EDTA, 0.6 M sodium chloride, 10% dextran sulphate (Sigma). Slides were covered with a hydrogen peroxide treated siliconized coverslip, (coverslips were washed in 3% hydrogen peroxide for 10 minutes, rinsed in DEPC treated sterile distilled water, dried in a warm oven and siliconized). The slide was then placed in a Petri-dish with several layers of filter paper moistened with 45% de-ionized formamide, 55% distilled water, the Petri-dish was sealed and incubated overnight. DNA hybridizations were carried out at 37°C and RNA hybridizations at 54°C.

Biotin labelled cDNA probes were used as control probes for the DNA/RNA hybridizations, whilst sense-strand biotin labelled RNA control probes were used in the RNA/RNA hybridizations.

2.3.3.3. Post Hybridization washes

Following the overnight incubation coverslips, were removed, in 4 x SSC at room temperature, followed by a second wash in 4 x SSC, 2 x 15 min. washes in 2 x SSC in the case of cDNA probes. With cRNA probes the slides were treated for 30 min at 37°C in 2 x SSC + 50 µg/ml RNAase in the case of cRNA probes, was followed by 30 min in 0.1 x SSC at 37°C and rinsed in 2 x SSC.

2.3.3.4. Probe Detection

The hybridized biotinylated probes were detected using the BRL detection kit; slides were washed in buffer 1 (0.1 M Tris-HCl pH 7.5; 0.1 M NaCl; 2 mM MgCl₂; 0.05% (v/v) Triton X-100), and blocked for 30 min in buffer 2 (3% (w/v) bovine serum albumin (Sigma) in buffer 1) at 42°C. 100 µl 2 µg/ml BRL streptavidin in buffer 1 was applied to each slide and incubated at room temperature for 20 min. Slides were washed for 3 x 5 min in a large volume of buffer 1, then incubated for 20 min in 1 µg/ml biotin-(AP), (biotinylated calf intestinal alkaline phosphatase). Slides were washed in buffer 1 for 2 x 5 min then buffer 3 (0.1M Tris-HCl pH9.5; 0.1 M NaCl; 50 mM MgCl₂), for 2 x 5 min, followed by incubation in the BRL dye solution which was prepared by adding 3.3 µl NBT (nitro-blue tetrazolium, 75 mg/ml in 70% dimethylformamide) and 2.5 µl BCIP (5-bromo-4-chloro-3-indolyl phosphate, 50 mg/ml in dimethylformamide), in 750 µl buffer 3. Coverslips were placed on the slides and incubated in the dark for 1-4 h. Coverslips were removed in buffer 3 and sections dehydrated through an alcohol series, counterstained with safranin in 70% ethanol, washed, and mounted in Histomount. Sections were viewed under a Nikon

microscope using either bright-field or Nomarski illumination. The labelled probes were shown up as the blue precipitate, against the pink, counterstained background.

Oligo dTT 16-18 probes were photo-biotinylated and hybridized to sections using the cDNA hybridization protocol, to illustrate the most active transcriptional activity within nodule sections.

2.3.3.5. *L. corniculatus* Hybridizations

After some experimentation, the pretreatment and incubation times were shortened for hybridizations with the smaller *L. corniculatus* nodules.

Sections were treated with; 0.2 M HCl for 15 min at room temperature, washed in distilled water, incubated in 2 x SSC at 70°C for 10 min, washed in distilled water, blotted dry then incubated in 1 µg/ml proteinase K in TE buffer at 37°C for 20 min. Sections were blotted dry, fixed in 4% paraformaldehyde in PBS for 10 min. The rest of the hybridization procedure was as outlined above for *P. vulgaris* nodule sections.

2.4. IMMUNO-LABELLING AND STAINING FOR β -GLUCURONIDASE

2.4.1. Immuno-Labelling of PEG-Embedded Sections for Light Microscopy.

P. vulgaris and *L. corniculatus* nodule sections were labelled with a GS antibody, (kindly provided by Dr. J. Cullimore (University of Warwick), and a GUS (β -glucuronidase) antibody kindly provided by Dr. M. Watson (University of Durham). Immuno-gold and alkaline phosphatase methods of antibody detection were both used.

2.4.1.1. Immuno-Gold Labelling of sections for light microscopy.

10 μ m PEG embedded sections were washed in distilled water to remove any excess PEG, then incubated in Lugol's iodine (1% iodine in 2% aqueous potassium iodide solution) for 5 min at room temperature, rinsed in tap water, washed in 2.5% sodium thiosulphate until they turned colourless, and then washed in running tap water for 10 min. Sections were blocked in 2% B.S.A. for 30 min at room temperature, and incubated with antibody diluted in PBS (GS anti-body 1/100, GUS 1/500) or with rabbit pre-immune serum or PBS as controls, for 1 h at room temperature. After incubation sections were washed for 2 x 15 min in PBS, followed by 2 x 15 min Tris-saline (0.15 M NaCl; 20 mM Tris-HCl; 0.1% B.S.A.; 0.01% Tween 20; pH 8.2), then incubated with a 1/50 dilution goat anti-rabbit (5 nm) gold in Tris-saline for 20 min at room temperature, and washed 2 x 15 min in Tris-saline, followed by 2 x 5 min in distilled water. Sections were silver enhanced for 10 min using Jansen silver enhancement kit, washed in distilled water, mounted in Citifluor (Agar Aids), and viewed under a Nikon microscope using an epi-polarising filter with fluorescent light (Nikon IGS optics).

2.4.1.2. Alkaline Phosphatase Protein Localization

The immuno-gold labelling method above was followed up to the goat anti-rabbit gold which was replaced by goat anti-rabbit alkaline phosphatase. This was used at a 1/100 dilution in Tris/saline; the bound enzyme was localized with the BRL biotin detection kit dye as outlined in 2.3.1.

2.4.2. Immuno-Gold Labelling of Resin Sections for Electron Microscopy.

Ultrathin sections were cut and collected on formvar-coated 200 mesh copper grids. Immuno-staining was carried out by floating grids, section side down on drops of solution placed on Nescofilm. Sections were dried between incubations and washes by touching wedges of filter paper on the lower edge of the grid.

Sections were blocked with 2% B.S.A. in PBS for 30 min at room temperature and dried, then incubated with primary antibody (at the same concentration used for the light microscopy procedure) for 1 h at room temperature, with the appropriate control sections, as described above. Sections were washed for 10 x 1 min in drops of PBS, then incubated in a 1/50 dilution of goat anti-rabbit 20 nm gold for 30 min at room temperature, washed for 10 x 1 min in PBS, followed by a stream of distilled water, stained in saturated aqueous uranyl acetate for 30 min, rinsed in distilled water and dried. The sections were then examined in a Philips EM 400 electron microscope at either 60 or 80 kV and images recorded on Kodak 4489 film.

2.4.3. β -Glucuronidase (GUS) Localization in Transformed *L. corniculatus* Plants

The compound 5-bromo-4-chloro-3-indolyl glucuronide (X-Gluc), forms a blue precipitate at the site of β -glucuronidase (GUS) enzyme activity in tissue, Jefferson *et al.* (1987).

Fresh tissue, either whole or chopped into thick sections, was incubated with 2 mM X-Gluc in 0.1 M phosphate buffer, 0.5 M potassium ferricyanide, 0.5 M potassium ferrocyanide and 10 mM EDTA. Tissue was incubated for 1-6 h, then either squashed on a slide, or fixed in 2.5% paraformaldehyde, 1.25% glutaraldehyde, dehydrated and embedded in Spurr resin and sectioned for a more detailed microscopic examination.

RESULTS AND DISCUSSION

3. THE STRUCTURE AND DEVELOPMENT OF *Phaseolus vulgaris* ROOT NODULES

An initial study of the developmental of *P. vulgaris* root nodules was carried out. The methods used for growing, harvesting, fixing, embedding, sectioning and staining of material were outlined in 2.1-2.4.

The exact time from inoculation is not necessarily an accurate guide to nodule maturity. Newcomb *et al* (1979a) classified soybean nodules by morphological appearance because of the considerable variation in nodule size, number per plant and time of initiation. For the purpose of this project nodule development stages has been divided into three stages early, 12-16 days after inoculation, intermediate, 16-21 days after inoculation, and late, 21-28 days after inoculation. The morphological characteristics typical of each stage are demonstrated in Plates 1-7. Early, intermediate and late developmental stages were used in this work to provide broad categories for the classification of nodule age and development.

3.1. STAGES OF NODULE DEVELOPMENT

3.1.1. Early Stage Nodules

Morrison-Baird and Webster (1982) reported that the first small white protrusions were evident on *P. vulgaris* roots 9-12 days after inoculation. Those shown in Plate 1 were harvested 12-16 days after inoculation, when they were pink-white in colour, and represent the typical 'early' stage of nodule development. The nodule tissues become organised according to the characteristic developmental pattern of a

particular plant species, the most marked difference being the development of spherical, determinate nodules on plants, such as bean, or oval, indeterminate nodules on plants such as pea. As with soybean the spherical nature of the nodules can be traced back to the globular mass of mitotically-active, cytoplasmically-rich, meristematic cells, which are derived from the outermost layers of root cortex (Newcomb *et al.* 1979b).

The central infected area of the early nodule contains both infected and non-infected cells (Plates 1a and 1b). At this early stage bacteria have been released from the infection thread, (there is a detailed account of this process in 1.2.2). Surrounding the centrally-infected region, is a ring of meristematic cells containing dense cytoplasm and a relatively small degree of vacuolation (Plate 1b). This cell layer is referred to as the inner cortex in this study. On the outer edge of this cell layer are the developing vascular bundles. These vascular bundles develop from the stele in the plant root, as illustrated in Plate 1b, to form a closed network around the periphery of the nodule (Prasad, 1973).

Adjacent to the vascular bundles and the meristematic cells is a ring of larger cortical cells which often become very vacuolate and develop thick secondary walls and become sclerenchymal in nature (Newcomb, 1981). Dixon and Wheeler (1986) refer to these cells as an endodermal layer; they consist of cells with suberised walls which have few intercellular spaces and thus present a diffusion barrier to gasses passing into and out of the nodule. This enables the low oxygen partial pressures to be maintained within the centre of the nodule. This 'mid-cortical' layer of thickened cells is illustrated in Plate

1a

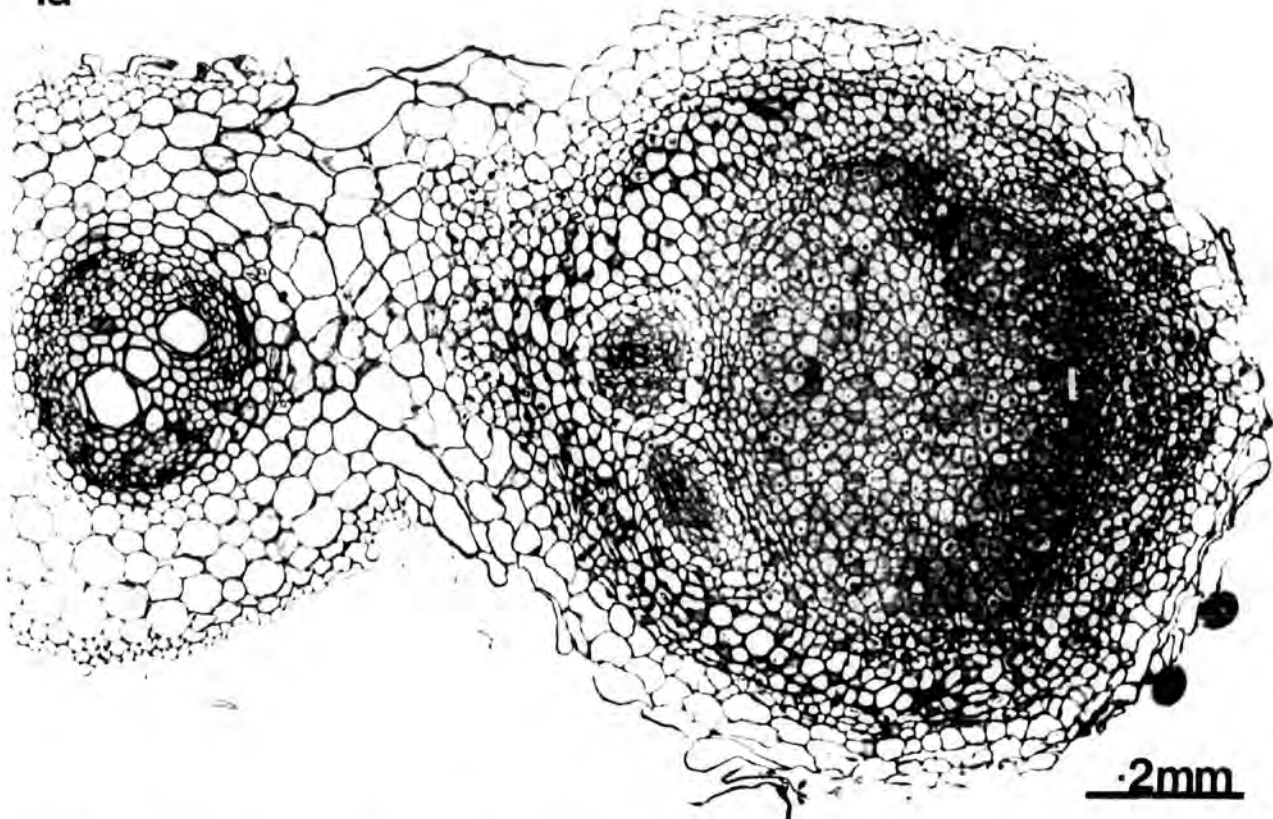
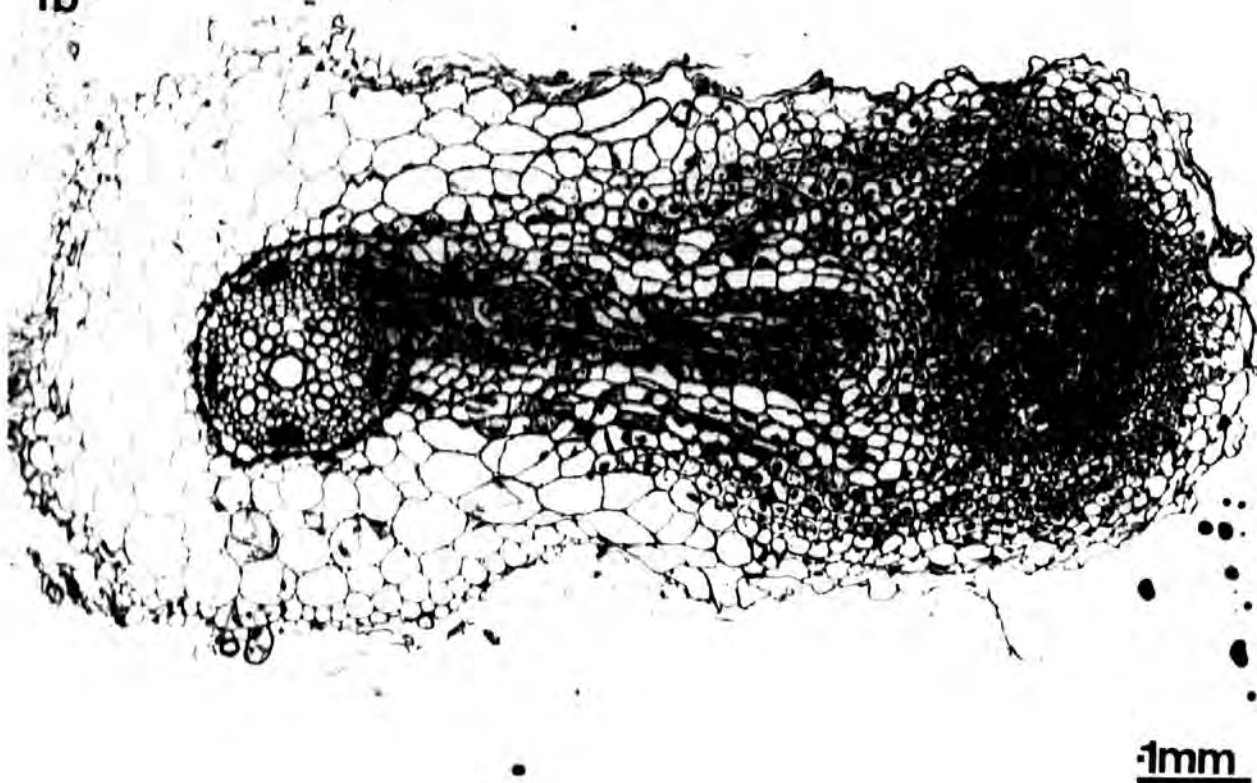

Plate 1. The attachment of early developing nodules to the plant root tissue. 1a shows a cross-section of the vascular bundles (VB), which form a network around the central infected region (I). Plate 1b shows a longitudinal section of the developing vascular tissue from the plant root to the nodule.

1b



1b. A layer of similar endodermal cells is located around the vascular bundles. These cells are referred to here as the vascular endodermal cells (illustrated in Plate 1b). The outer layer of cells, beyond the mid-cortex form the outer-cortex; also illustrated in Plate 1b.

In spherical nodules infection occurs in localised zones particularly in the ring of meristematic cells (Plate 2a). This localized infection has also been observed by Robertson and Farnden (1980). Syono *et al.* (1986) suggested that cells stop dividing in determinate nodules after infection (with the exception of peanut) although Newcomb (1981) suggested that soybean does undergo mitotic activity after infection in order to distribute the *Rhizobium* throughout the tissue.

From the developmental study carried out as part of this work, cell division does appear to continue after infection, although this may be confined to non-infected cells, as the number of cells within the infected region increases with the age of the nodule, as illustrated in Plates 2 and 4.

The large rhizobially-infected cells, with characteristically large nuclei and nucleoli, are distributed amongst a large number of smaller non-infected cells. Verma and Long (1983) estimated that 20-50 % of cells in the central region of the nodule remained uninfected. These non-infected cells are reported to have a relatively low DNA content, 2-4 C, whereas infected cells have 4, 8 or 16 C (Libbenga and Bogers 1974). Infection threads have not been observed to enter these non-infected cells (Newcomb, 1981). The radial arrangement of these non-infected cells may be connected with their possible role of aerating the internal nodule tissues (Bergersen and Goodchild, 1973a)

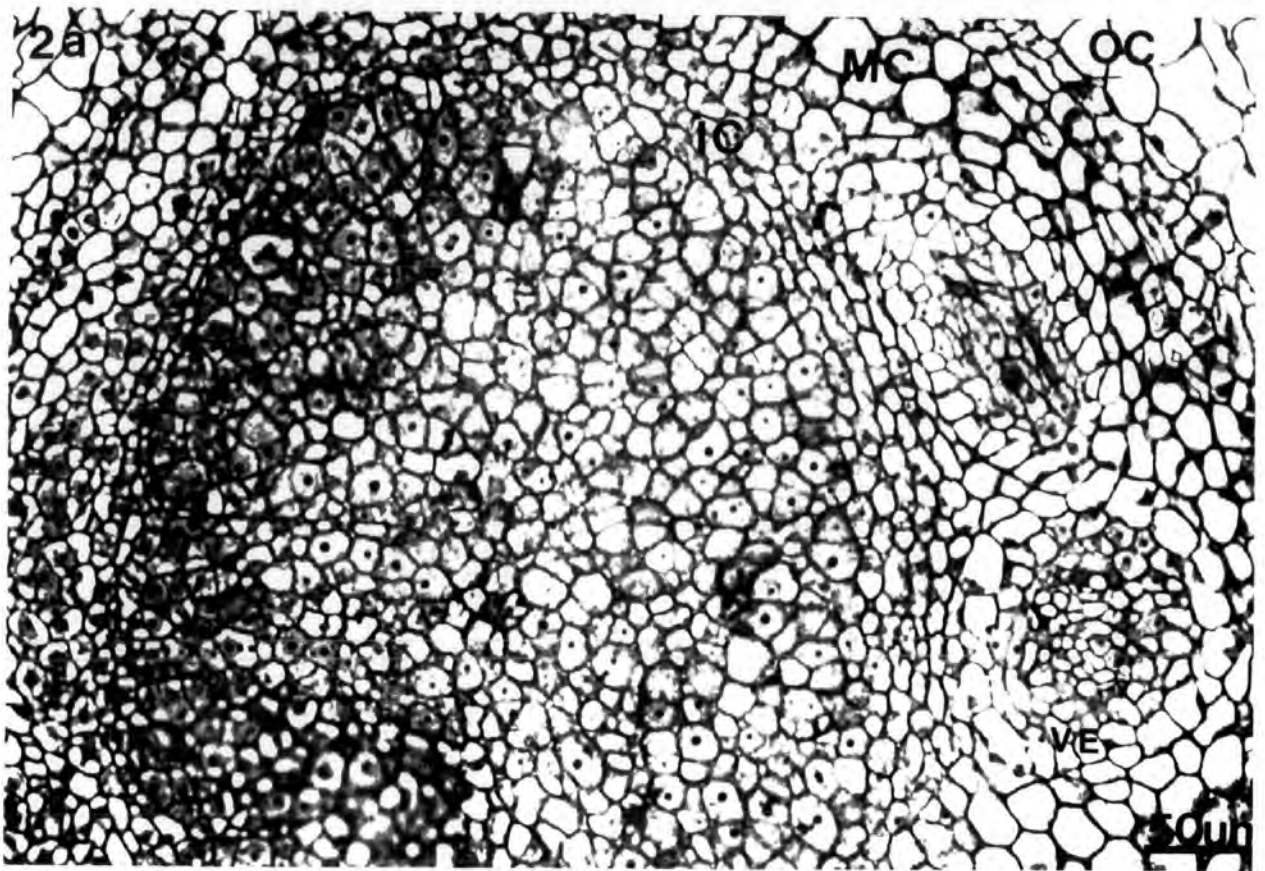
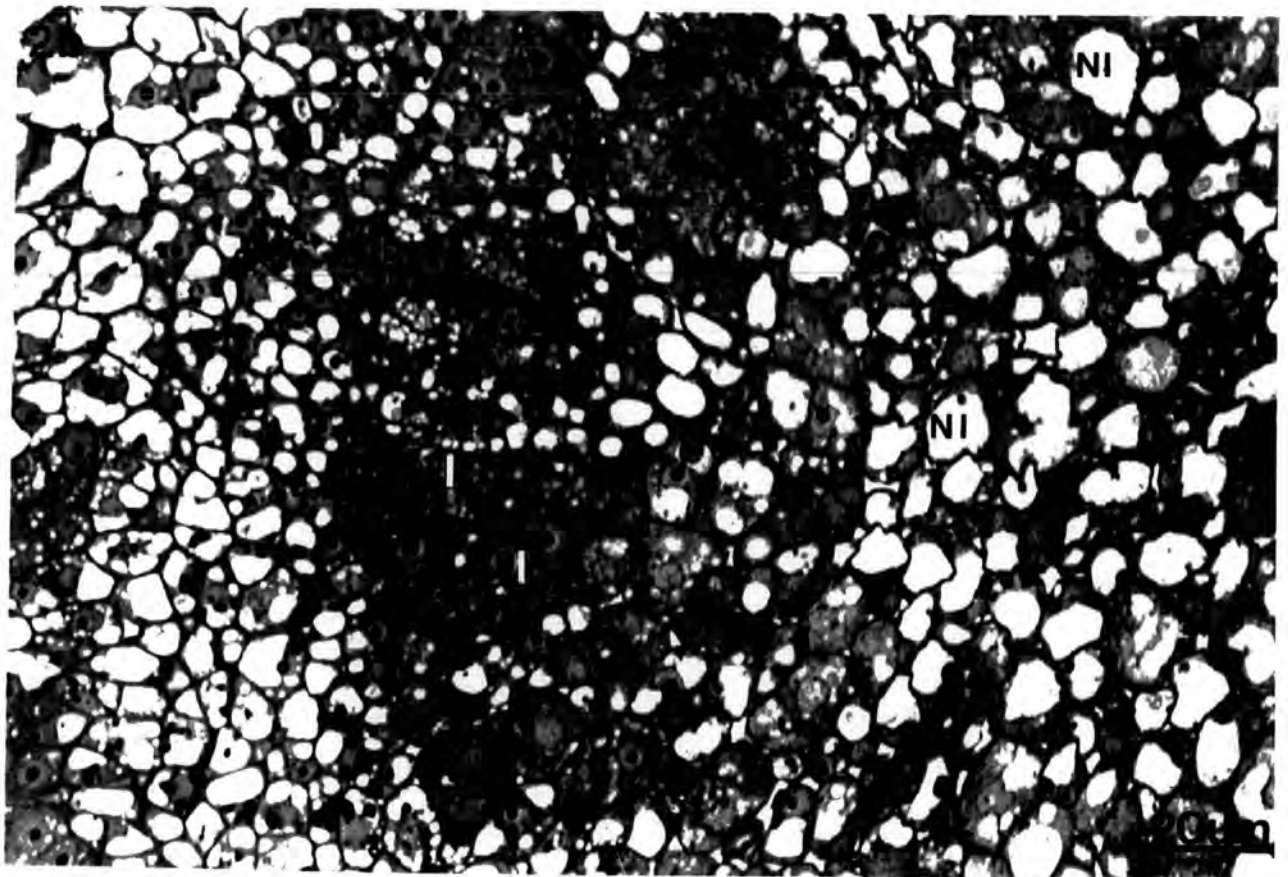

Plate 2. The central infected tissue of an early nodule is shown in more detail, in Plate 2a the inner cortical (IC), mid cortical (MC), outer cortical (OC), and vascular endodermal (VE), tissue can be clearly distinguished. 2b shows the early infected cells (I) with enlarged nuclei interspersed with the vacuolate non infected cells (NI).



The high level of carbohydrate reserves, in the form of starch, within the smaller non-infected cells is illustrated in Plate 3a. In contrast to mung bean, which has large spherical starch grains in the infected cells, and pea (Newcomb, 1976), and alfalfa (Vance et al, 1983) which have large flat starch grains in the infected cells, the starch grains in the infected cells of *P. vulgaris* seem to disappear rapidly during early infection as the bacteroids multiply. There is an increased proliferation of endomembrane systems, including rough endoplasmic reticulum, Golgi apparatus and vesicles in infected cells (Goodchild and Bergersen 1966) which is demonstrated in Plate 3b.

The bacteria within the infected cells are predominantly located around the considerably-enlarged nucleus, Plate 3b. Goodchild and Bergersen (1966) similarly observed this clustering of bacteroids around the nucleus in early soybean nodules, and reported that there were no apparent connections between the bacteroids and the nucleus, as had been suggested by Mosse (1964).

3.1.2. Intermediate Stage Nodules

A typical intermediate stage *P. vulgaris* nodule, approximately 16-21 days after inoculation, is shown in Plate 4. At this stage the nodules are 2-4 mm in diameter and sometimes lobed. The nodules are a deep pink colour with lenticels of white callus-like tissue around the outside.

As Newcomb (1979b) reported with soybean nodules, more mature *P. vulgaris* nodules can differ significantly from their younger counterparts. The older nodules have a much larger centrally-infected region and a narrow but well-defined, cortical region. Prasad (1973)

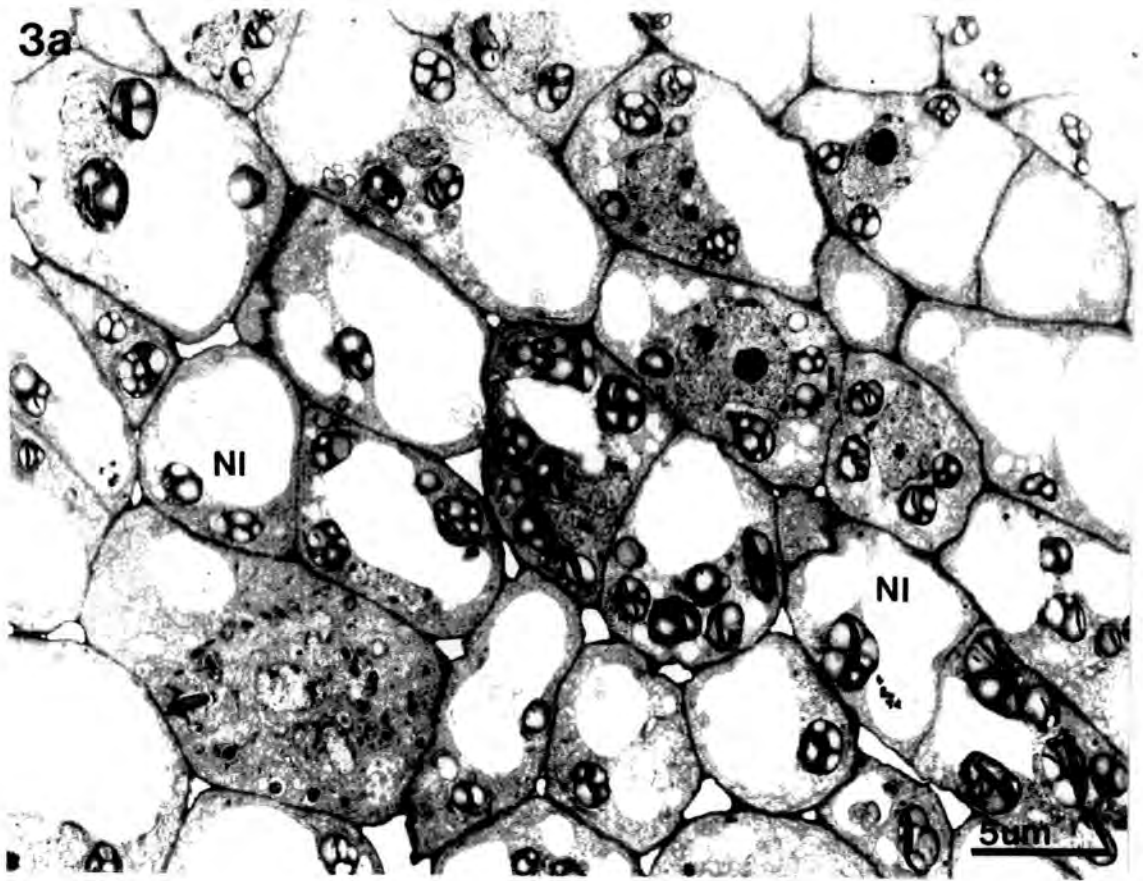
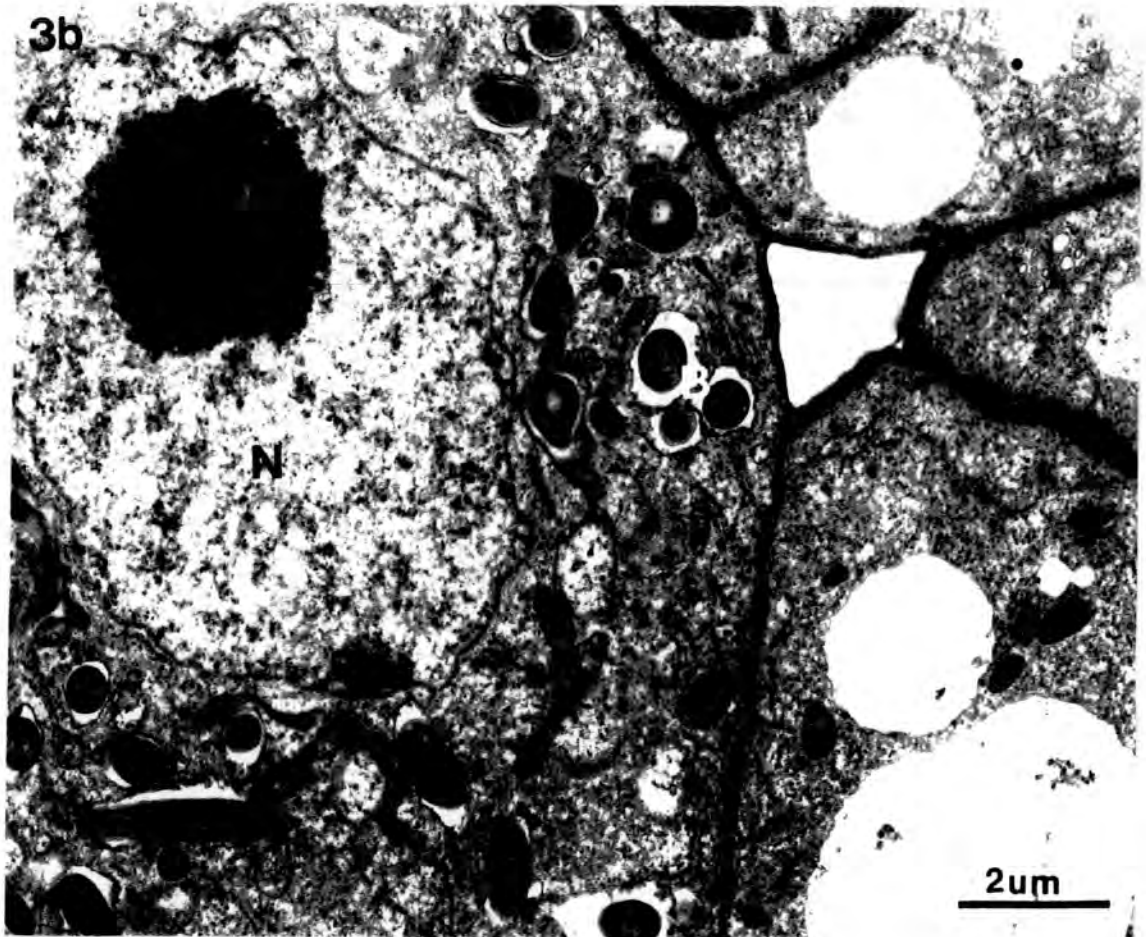

Plate 3 Electron micrographs of a section through an early root nodule. Plate 3a shows the large number of starch grains (S), in the vacuolate non-infected cells (NI). Plate 3b, shows the bacteroids (B), grouped around the nucleus (N), of an early infected cell.



4

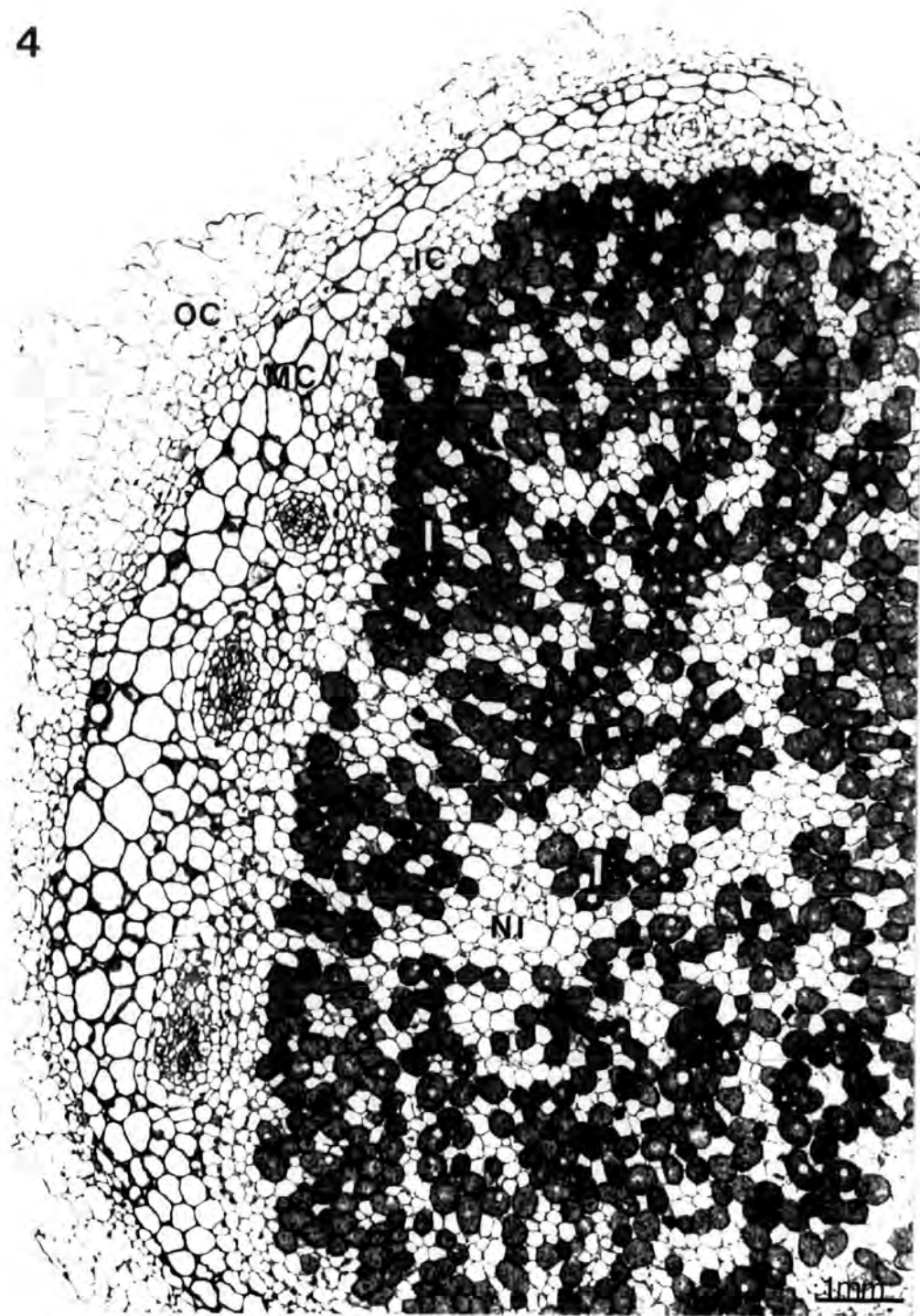

Plate 4, shows a section through a mid stage nodule. The infected cells (I), are more evenly distributed throughout the central region, with the non infected cells (NI), forming a radial pattern between them. The thickened mid cortical cells (MC), are clearly defined between the inner cortex (IC) and the outer cortex (OC).

divided spherical nodules into 4 distinct zones; the central bacteroid zone, the nodule meristem, vascular tissue and the cortical region. For the purpose of this project these regions have been further subdivided, as described in the following summary of the structure of *P. vulgaris* root nodules.

In the central bacteroid region, the infected cells are abundant, relatively small and have a centrally-located nucleus. The vacuolate, non-infected cells, which have a peripherally-located nucleus, are interspersed throughout the infected cells forming a radial-pattern which may help aeration of the central region; large numbers of these non-infected cells are confined to the outer edge of the infected region (Prasad, 1973). This region is termed the inner cortex for the purpose of this project. Dart (1977) suggested that there was only limited mitotic activity in soybean nodules after infection and that this was confined to the inner cortical regions and around the vascular bundles, although Newcomb (1981) was unable to demonstrate this.

The vascular bundles on the outer edge of this inner cortex consist of a layer of endodermal cells, a layer of pericycle, and a ring of phloem surrounding the xylem in the middle (Pate *et al.*, 1968). Calcium oxalate crystals are located in the outer, large suberised cells, which are termed, for the purpose of this project, the mid cortex. It has been proposed that these crystals are a form of waste product (Sutherland and Sprent, 1984) which forms as a result of a build up of calcium, caused by the barrier to apoplastic transport at the mid-cortical cells (Harrison-Murray and Clarkson 1973). The outer layer of cells forming the outer cortex, is often irregular as some of these cells become sloughed off.

In intermediate stage nodules the infected cells are considerably larger than the non-infected cells, and packed with bacteroids around the enlarged nucleus, as illustrated in Plate 5b. The starch reserves in the non-infected cells, at this intermediate stage, are considerably reduced, or absent. As the infected cells increase in size the intercellular spaces also become considerably larger.

Mitochondria become confined to the cell periphery of the infected cells, and are concentrated in regions adjacent to non-infected cells and intercellular spaces (Plate 5b). Peroxisomes are also abundant in the non-infected cells at this stage (Plate 5b). Hanks *et al* (1983), have demonstrated that the peroxisomal enzymes uricase and catalase are at much higher specific levels in non-infected cell fractions of soybean. Newcomb and Tanden (1981) reported that the enlargement of peroxisomes and proliferation of smooth endoplasmic reticulum during nodule development were confined to non-infected cells of the nodule and suggested they had a role in the ureide metabolism, and Vanden Bosch *et al* (1986) have confirmed this by demonstrating the presence of uricase in the non-infected cells of *P. vulgaris* root nodules by immuno-gold labelling.

The bacteroids, contained within their peribacteroid membrane within an infected cell, are shown at a high magnification in Plate 5c. The number of bacteroids within a peribacteroid membrane can vary from 1-2 in pea, up to 16 in mung bean, but is normally 2-6 in beans (Verma and Long, 1983). The morphology of the bacteroids is influenced by the host (Verma and Long, 1983); different plant bacteroids assume different characteristics, for example, peanut forms large spherical bacteroids, pea and broad bean bacteroids assume Y or X shapes, whilst

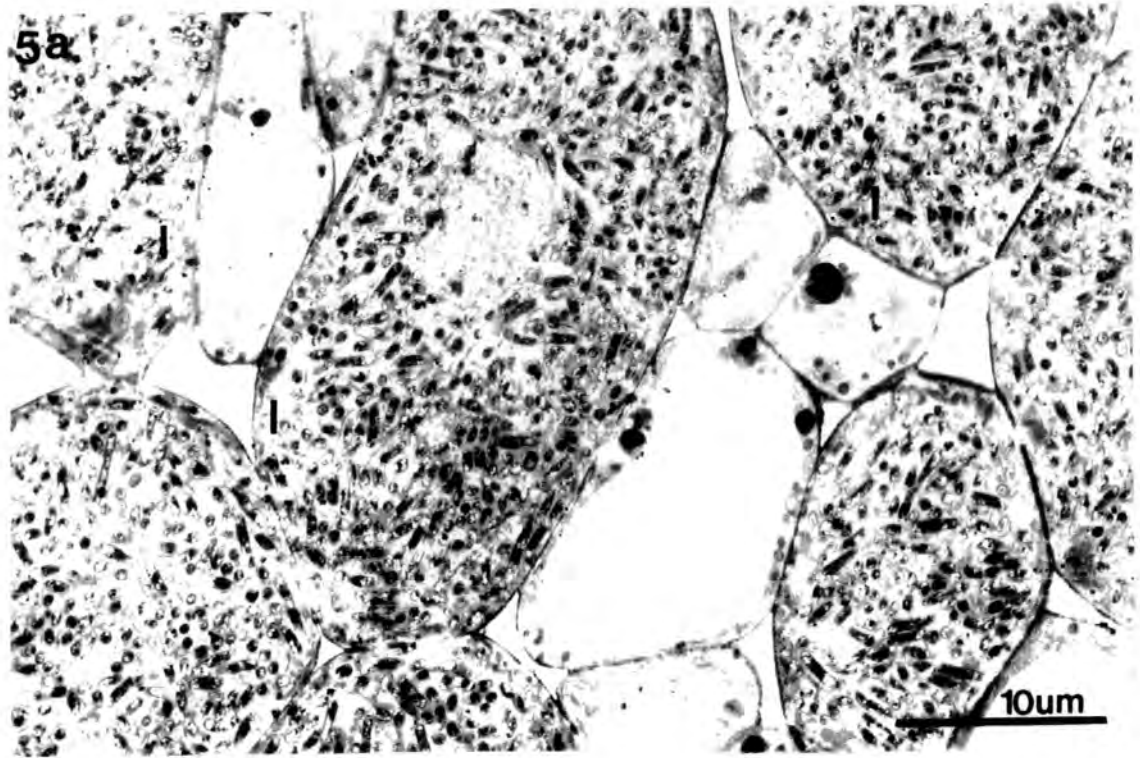

Plate 5. At the mid stage, the infected cells are packed with bacteroids, Plate 5a. 5b shows the host plant organelles in the infected cell clustered around the intercellular spaces and non infected cells, small peroxisomes (P), are the main feature of the non infected cells. Plate 5c shows a higher magnification of the bacteroids contained within the peribacteroid membrane (PBM), in the infected cells



they form an elongate oval shape in beans (Robertson and Farnden, 1980). The transition from free-living *Rhizobium* to bacteroids is often accompanied by a reduction in cell wall thickness and rigidity, together with changes in the outer membrane (Verma and Long, 1983). Bisseling *et al.*, (1977), reported that DNA levels within the bacteroids can increase from 1.6 to 8 fold. The accumulation of β -hydroxybutyrate, a lipid-like storage product, shows up as electron translucent regions within the bacteroids, and can account for up to 30% dry weight of the bacteroids in soybean (Goodchild and Bergersen 1966).

3.1.3. Late Stage Nodules

At the late stage, 21-28 days after inoculation, nodules turn a brownish colour due to the degrading leghaemoglobin. Infected cells in the central region become very elongated, (Plate 6) and the cell walls begin to degenerate.

Prasad (1973) proposed that the senescence of the central region occurs from the sides towards the centre, although Goodchild (1977) suggested that the older tissue tends to be located towards the centre of the infected area. Senescence may, however, occur almost simultaneously over a major portion of the infected tissue (Robertson and Farnden, 1980). The results presented here demonstrate that in *P. vulgaris* senescence occurs from the centre of the infected region outwards or simultaneously all over.

There are a large number of well-developed peroxisomes in the non-infected cells (Plate 7a). These non-infected cells also have large intercellular spaces. The infected cells at this late stage become tightly packed with rhizobia (Plate 7a).

6



100um

Plate 6 shows a section through a late stage nodule. The infected cells have become very dark, due to the degrading leghaemoglobin in these senescing cells

7a

Plate 7 In late stage nodules, the bacteroids, surrounded by large peribacteroid spaces, are packed in the infected cells—Plate 7a. Plate 7b shows the large number of peroxisomes (P), packed in the non infected cells. 7c, shows the bacteroids containing high levels of β hydroxybutyrate crystals, (shown as electron translucent regions), surrounded by a large peribacteroid space (PS), within the peribacteroid membrane.

7b**7c**

Dilworth and Williams (1969) and Bisseling *et al.* (1979) have both reported a rapid decline in RNA content, RNA/DNA ratio and the RNA/protein ratio within mature (late stage) nodules.

Morrison-Baird and Webster (1982) have reported that the peribacteroid membrane degenerates (this is shown in Plates 7a and 7c), although the bacteria do not apparently undergo any significant ultrastructural changes until the rest of the nodule has degenerated. Prasad (1973) suggested that the bacteroids do not degenerate significantly until the host cytoplasm and intercellular walls have degenerated.

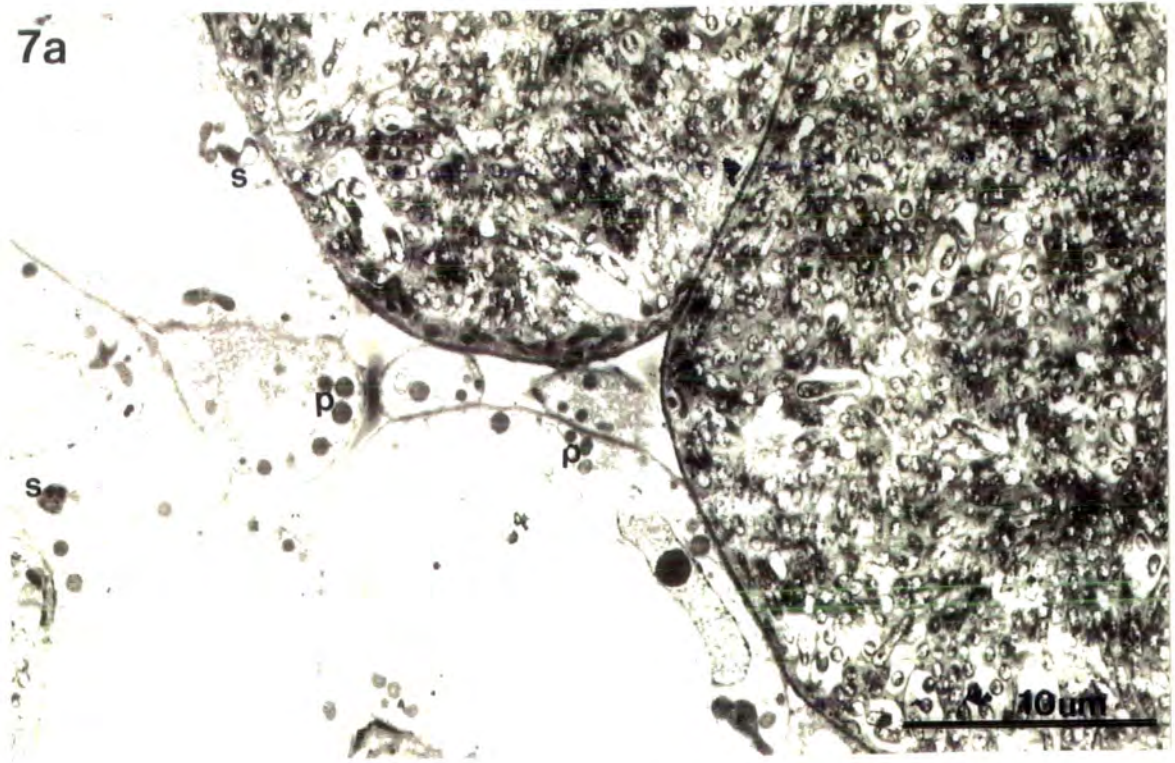
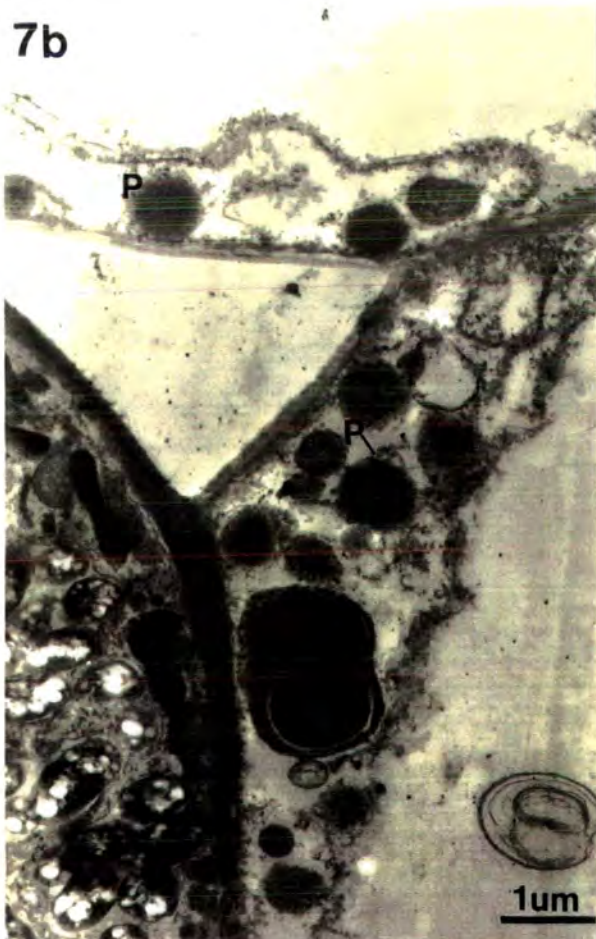
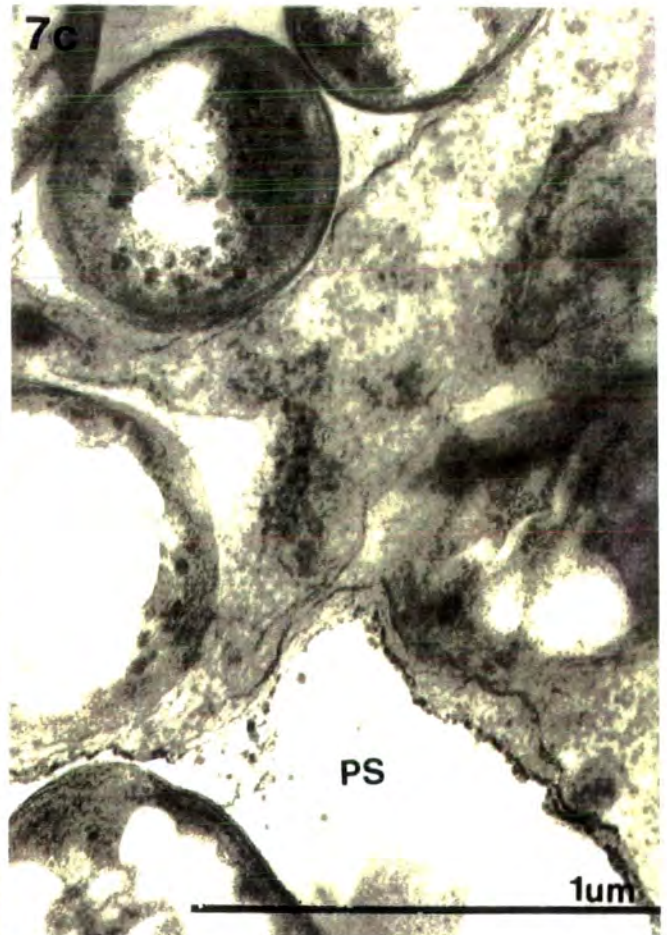
High levels of β -hydroxybutyrate collect within the bacteroids, and large peribacteroid spaces form as a result of the degrading peribacteroid membrane, in late stage nodules (Plate 7a and c).

This developmental study of *P. vulgaris* nodules has provided the basis on which the *in situ* histochemical studies have been carried out.

4. THE APPLICATION OF *In situ* HISTOCHEMICAL TECHNIQUES.

The advantages that can be gained from the use of *in situ* histochemical techniques over more conventional biochemical and molecular methods of investigating gene expression in the root nodule symbiosis, have already been discussed in Chapter 1. The root nodule provides a unique situation in which the plant/bacteria symbiosis results in a pattern of differential gene expression throughout of the root nodule. The arrangement of rhizobially-infected cells and non-infected cells makes the physical separation, and therefore analysis of gene expression in the different cell types, extremely difficult by homogenization-based techniques.

In situ hybridization allows the localization of different RNA, or DNA sequences to specific cells, and therefore cell specific expression and regulation of defined mRNA species can be studied. Immunocytochemistry allows the corresponding specific proteins to be localized to particular cell types. Jeffersen (1988), however, warned that *in situ* techniques, particularly hybridizations are not as straightforward as they may first appear, and can require a great deal of work to achieve accurate, reliable and reproducible results. This has certainly been the case in this project.

At the start of this research relatively few examples of *in situ* hybridization had been described in plant biology. Harris and Croy (1986), Martineau and Taylor (1986), Smith *et al.* (1987), Parthasanathy (1987), and Meyerowitz (1987) were some of the first to publish *in situ* hybridization results on plants. More recently as techniques have advanced there have been many more reports of successful *in situ*

hybridizations on plant tissue (e.g. Schmelzer *et al.*, 1988, Raikhel *et al.*, 1989, Nelson and Langdale, 1989, McFadden *et al.*, 1988, Meeks-Wagner *et al.*, 1989, Gasser *et al.*, 1989, Comai *et al.*, 1989).

Cox *et al.* (1984) suggested that the usefulness of *in situ* hybridization depends on the sensitivity of the method and the accuracy with which signals reflect local concentrations of target mRNAs.

Hafen *et al.* (1983) proposed five basic parameters for successful *in situ* hybridizations including;

1. RNA retention during the preparation of tissue sections.
2. the accessibility of the target RNA for hybridization.
3. the efficiency of probe hybridization to the complementary mRNA.
4. the specific activity of the labelled probe.
5. the efficiency and sensitivity of detection.

The achievement of optimum conditions for legume root nodule hybridizations are described and discussed in this Chapter.

4.1. TISSUE PREPARATION

4.1.1. Fixation of Tissue

A variety of fixatives were used on *P. vulgaris* nodules in order to ascertain the optimal fixative, for both RNA and cell preservation. The fixation methods tried are outlined in Table 3 and the results summarized in Table 4.

Fixed material was dehydrated, embedded, sectioned and stained for RNA retention and structural integrity as described in Chapter 2.1.3. The sections were then scored for both RNA staining and cell preservation. The highest scoring fixatives were then considered on the

of sectioning and reproducibility of good sections. Pretreatments and hybridizations were then carried out and sections stained for mRNA, and the degree of hybridization compared.

Table 3. (as table 1) Tissue fixation conditions.

Fixative	time / temperature	1st wash
1. 70% EtOH/30% HOAc	20 min R.T.	70% EtOH
2. 95% EtOH/5% "	15 min "	95% "
3. 75% EtOH/25% HOAc	15 min "	75% "
4. 100% EtOH	48 h -80°C	100% EtOH
5. 70% EtOH/30% dH ₂ O	20 min 4°C	75% EtOH
6. 100% Methanol	20 min -20°C	70% EtOH 4°C
7. 100% Acetone	20 min -20°C	70% EtOH 4°C
8. 50% Acetone/50% methanol	20 min -20°C	50% EtOH 4°C
9. 4% para in PBS	20 min R.T.	PBS.
10. 4% para in PBS	20 min 4°C	PBS
11. 10% formald./90% methanol	20 min 4°C	PBS
12. 2.5% para. in PBS	30 min R.T.	PBS
13. 1% glut. in 0.05M cacodylate buffer.	3 h R.T.	Cac. Buffer.
14. 1% glut. in PBS	3 h R.T.	PBS.

EtOH - absolute ethanol, HOAc - acetic acid, para - paraformaldehyde, glut - glutaraldehyde.

A second set of fixations were carried out under similar conditions to those listed above but fixed overnight. The short fixations are denoted 'a', and the overnight fixations 'b', in the following results.

Table 4. Results of fixative assessment.

Fixative	Staining	Cell preservation	Overall
1a	3 infected strong	3 reasonable	6
2a	2 faint	2 poor	4
3a	4 non-infected faint	4 good	8*
4a	0	3 reasonable	3
5a	1 infected v. faint	4 good	5
6a	2 faint	3 reasonable	5
7a	4½ good	4½ v. good	9*
8a	4½ good	4½ v. good	9*
9a	4 patchy	4 good	8*
10a	2 v. patchy	4 good	6
11a	2 v. patchy	1½ v. broken	3½
12a	4 good	3 hard to section	7
13a	4½ v. good	4½ v. good	9*
14a	3½ pale	3½ bitty	7
1b	4 good	3 bitty	7
2b	4 good	3 reasonable	7
3b	1 faint	2 poor	3
4b	could'nt section	0	0
5b	2 pale	1	3
6b	3	3	6
7b	2 v. patchy	2 poor	4
8b	4½ good	3½	8*
9b	2	3½	5½
10b	1 v. faint	1½	2½
11b	2 faint	2	4
12b	3	1½	4½
13b	4 good	4 good	8*
14b	4 good	3½	7½

* Sections scoring 8 or more were considered further.

Plate 8 demonstrates some of the contrasts observed with the different fixatives.

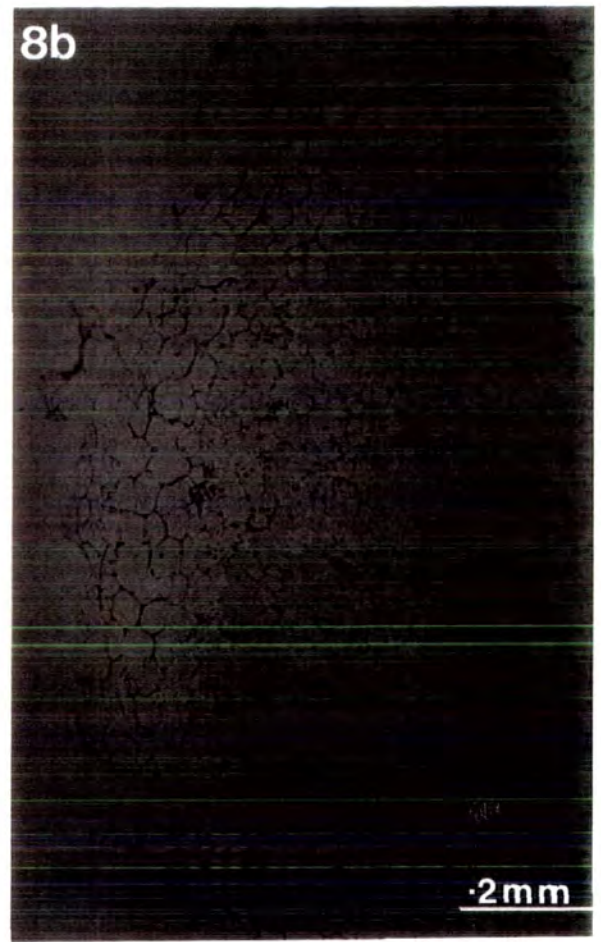
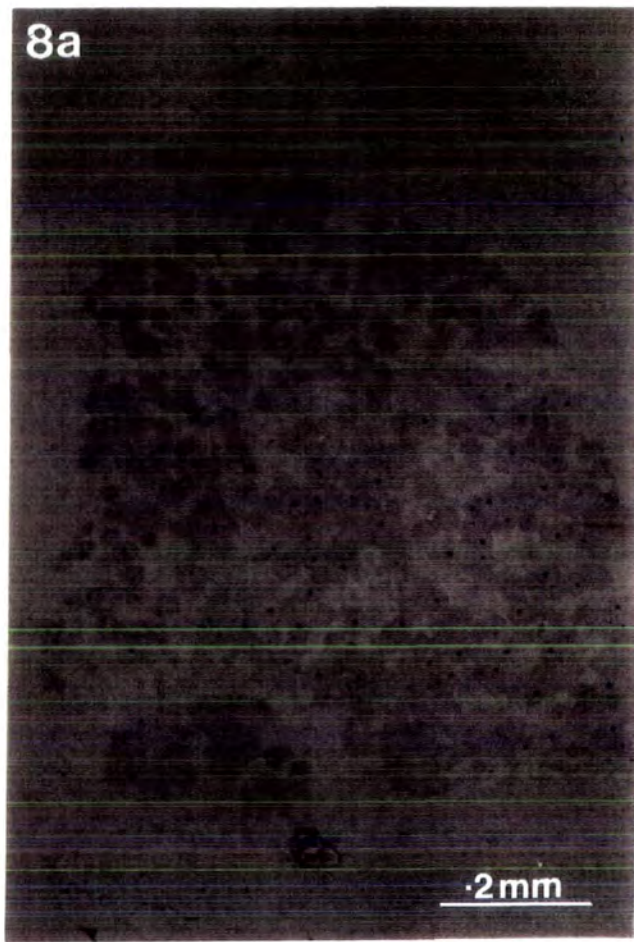
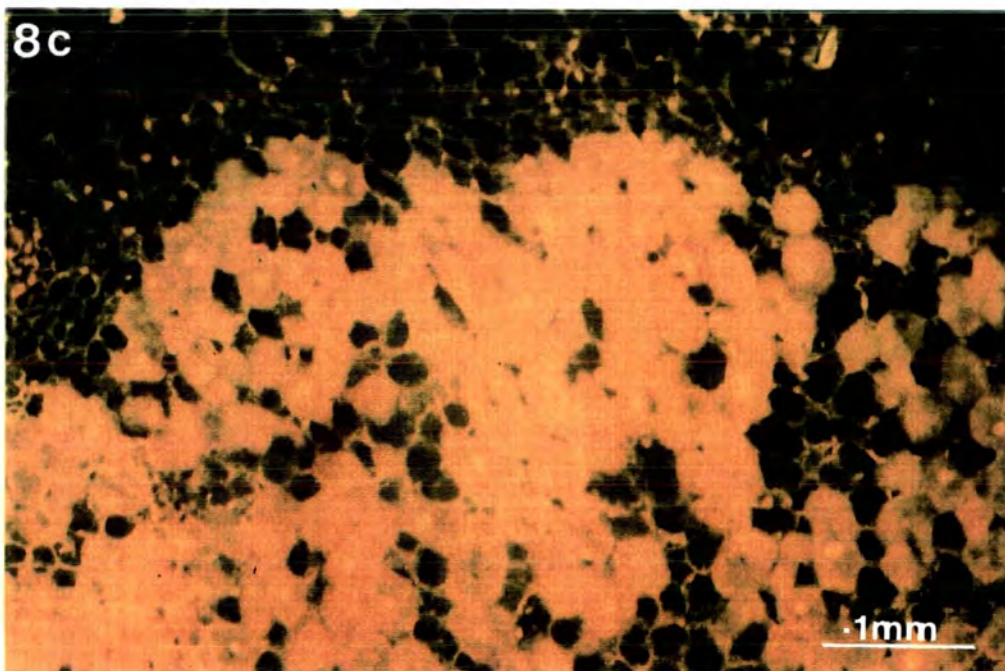

Plate 8 The differences in the RNA preservation by different fixatives; Plates 8a and b, show sections stained with methyl green pyronin. 8a, shows a well fixed section, in contrast the section in 8b shows little or no pink staining and representing very poor RNA preservation, although the cellular preservation is good. Plate 8c shows a section with good RNA preservation stained with acridine orange, the orange/yellow staining represents the RNA.



The better fixatives were assessed in various pretreatments and hybridizations. The best fixative which resulted in the production of good root nodule sections, which were able to withstand the hybridization conditions and produce reliable results, was 1% glutaraldehyde in 0.05 M sodium cacodylate buffer for 3 h (13a).

In this study the ethanol and acetic acid based fixatives, resulted in very poor cell preservation. Dietrich *et al.* (1988), found that an overnight fixation in 10% formalin, 5% acetic acid and 50% ethanol was the best fixative for *Brassica napus* seedling tissue used for *in situ* hybridization. Brahic and Haase (1978) also suggested that the acetic acid-methanol and methanol-acetone fixatives gave the best hybridization efficiencies. Experiments on pea cotyledons in our laboratory also indicated the ethanol-acetic acid fixatives were superior for that particular tissue, with regard to RNA retention and accessibility.

Angerer and Angerer (1981) suggested that glutaraldehyde-fixed tissue showed better RNA retention than ethanol acetic acid fixatives. This, together with the good cell preservation, was the case with *P. vulgaris* root nodule tissue.

Perrot-Rechenmann *et al.* (1989) in contrast, reported that paraformaldehyde was better than glutaraldehyde as a fixative for *in situ* hybridizations on maize leaves. This was also found to be preferable by Harper *et al.* (1986) who suggested that paraformaldehyde fixatives were preferable provided they were followed by pre-hybridization treatments to make the tissue more accessible. Singer *et al.* (1986) found paraformaldehyde a good fixative and glutaraldehyde also good provided it was used with protease pretreatments and small

probes.

McFadden *et al.* (1988) found a paraformaldehyde-glutaraldehyde combination gave better morphological preservation of plant tissues than paraformaldehyde alone as did Schmelzer *et al.* (1988). Guitteny *et al.* (1988) suggested an increasing formaldehyde concentration in the fixative decreased the signal intensity, whilst Godard and Jones (1978) found glutaraldehyde to be a superior fixative as did Angerer, Cox and Angerer (1981) particularly at a 1% concentration, as was found in this work.

From the wide variety of reported fixation preferences, Bresser *et al.* (1986) suggested that 'only one or two fixatives are suitable for each particular tissue', and it is thus important that optimal fixatives are determined empirically for each particular tissue type.

4.1.2. Embedding of Tissue

Different embedding protocols were used with the best fixatives and tissue then compared for RNA preservation, cell preservation, and sectioning quality. The following embedding media were assessed (out of a maximum score of 5).

Table 5. The assessment of embedding media

Embedding material	Sectioning	Cell preservation	RNA preservation
PEG 1500	2	4	4
PEG 1000	5	4	4
WAX	5	3	5
L.R. White	4	5	0
L.R. Gold	4	5	½

The results demonstrate that each embedding medium has its own advantages. PEG 1000 was superior to PEG 1500 due to the sectioning properties which therefore allowed a much higher quality of sections to be obtained.

Wax, despite the good sectioning and RNA preservation, resulted in a poorer quality of cell preservation (as illustrated in Plate 9). The L.R. Gold and L.R. White required an ultramicrotome for sectioning. Although this allowed semithin and thin sections to be cut, which could also be used at the electron microscope level, the RNA preservation was almost non-existent, although the cell preservation was excellent.

McFadden *et al.* (1988) embedded tobacco pistils, anthers and mature pollen in L.R. Gold and reported good RNA preservation and successful *in situ* hybridizations, but I have been unable to repeat this. This technique may be worthwhile investigating further, as it would allow *in situ* hybridization to be carried out at both the electron and light microscope level.

For the *in situ* hybridization work PEG 1000 was found to be the best embedding medium. Despite its low RNA preservation (or accessibility), L.R. White does provide good preservation of antigenic sites (Craig and Miller, 1984), and is therefore very good for immunolabelling studies at both the light and electron microscope levels. This is particularly good for electron microscopic immunolabelling, where PEG 1000 sections could not be used.

Perrot-Rechenman *et al.* (1989) and Schmelzer *et al.* (1988) found frozen sections preferable to embedded sections, although Larsson *et al.* (1988) found paraffin-wax embedded sections were far superior to cryosections. Frozen root nodules were found difficult to handle, and

cryosections were inferior to the embedded ones in my experiments.

Plate 9a illustrates a root nodule section fixed in 1% glutaraldehyde, PEG embedded and hybridized with a biotinylated probe; annealed probe was localized by the blue alkaline phosphatase staining. This is compared with similarly treated wax-embedded tissue also hybridized with a biotinylated probe (Plate 9b). The superior cell morphology in the PEG section is quite evident. Tissue sections fixed as in 9a, were also stained for RNA with methyl green pyronin, after pretreatments and hybridization. The pink staining shown in Plate 9c illustrates the distribution of retained/accessible RNA.

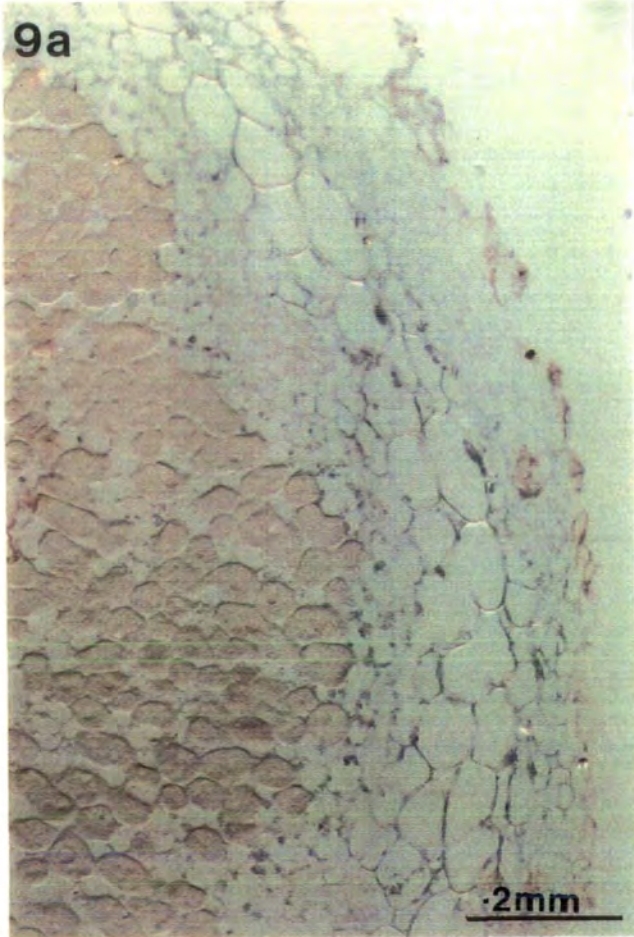
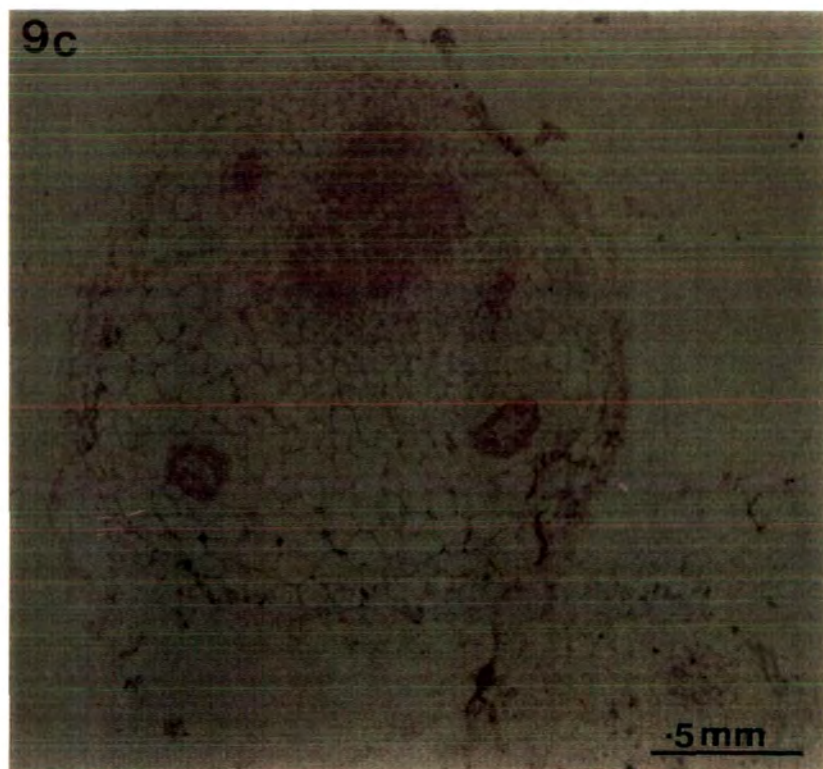

Plate 9 9a and b, illustrate the differences between embedding media; 9a, shows a section fixed in 1% glutaraldehyde, embedded in PEG 1000, hybridized with a biotinylated probe, and labelled with alkaline phosphatase. 9b shows a wax embedded section treated in the same way. Plate 9c shows a section fixed in 1% glutaraldehyde, embedded in PEG 1000, and stained for RNA with methyl green pyronin after the hybridization steps.



4.2. *In situ* HYBRIDIZATION TO CYTOSOLIC mRNAs

4.2.1. Preparation and Labelling of Probes

Over the last five years the techniques available for obtaining and preparing probes, and labelling them have shown considerable advances. Most early *in situ* hybridizations utilised cDNA probes (Brahic and Haase, 1978; Smith *et al.*, 1987, Hafen *et al.*, 1983; Harris and Croy, 1986). cDNA probes are however generally double-stranded and require denaturation by boiling prior to hybridization. During hybridization the separated DNA strands may reanneal to a variable extent and therefore limit the effective concentration of the hybridization probe. RNA and oligonucleotide probes have the advantage of being single-stranded, and therefore eliminate the reannealing problem. RNA probes also allow the use of a ribonuclease enzyme after the hybridization to clean up any non-specific background. Cox *et al.* (1984) reported that a dramatic increase in hybridization efficiency was obtained by using single stranded RNA probes. Meyerowitz (1987) and Angerer, Cox and Angerer (1987) both used RNA probes which they reported resulted in lower non-specific labelling than that produced by cDNA probes. Lathe (1984) first reported the use of oligonucleotide probes and Larsson *et al.* (1988) successfully used these probes for *in situ* hybridizations.

With this evidence and some early experiments, it was decided to construct and use RNA probes. Bresser *et al.* (1987) suggested that small probes (75-100 bp) were superior for *in situ* hybridizations the medium sized (100-400), or large (500-1000 bp) ones. Small to medium sized inserts (illustrated in Figure 1 Chapter 2.2.2.1.) were therefore

chosen from the 5' and 3' untranslated regions of the α , β and γ GS cDNA sequences.

The sequences from the 3' ends of the γ and β genes had short poly (A⁺) tails, although provided the hybridization and washing conditions were correct it was not anticipated that these would cause any problems. Larsson *et al.* (1988) used oligonucleotide probes with homopolymer tails; they reported that even long-tailed probes did not cause non-specific binding. The addition of poly dT or poly dC in the prehybridization or hybridization buffers produced no noticeable effects when the stringency of conditions was correct, and they subsequently omitted them.

Dietrich *et al.* (1984) demonstrated that probes of different lengths and concentrations cannot be quantitatively compared. This has also been demonstrated with the α , β and γ probes used in this project as illustrated in the following section.

The specified cDNA inserts were successfully subcloned into a pBS Bluescribe vector as described in Chapter 2.2.2. The subcloned inserts were then excised and used to probe a Southern blot containing the required inserts (described in Chapter 2.2.2.4.) All the probes bound specifically to the correct sequences, and demonstrated that the correct inserts had been cloned. The results of this blot are shown in Plate 10a.

Several different methods of probe labelling, both radioactive and non-radioactive, have been used for *in situ* hybridizations, both in this project and in previously reported work.

Radiolabelling has proved successful in many instances; Dietrich *et al.* (1984) successfully used RNA probes labelled with ³⁵S, Taneja

10a

N-1 R-1 R-2 R-2

N-1R-1R-2R-2



— 2700bp —

— 1100 —

— 700 —

— 350 —



Plate 10 10a shows the results of Southern blots, probed with the glutamine synthetase α , and β probes, to check for their specificity, as described in the methods.

Plate 10b, shows a typical set of 'detection strips' used to determine the level of probe labelling.

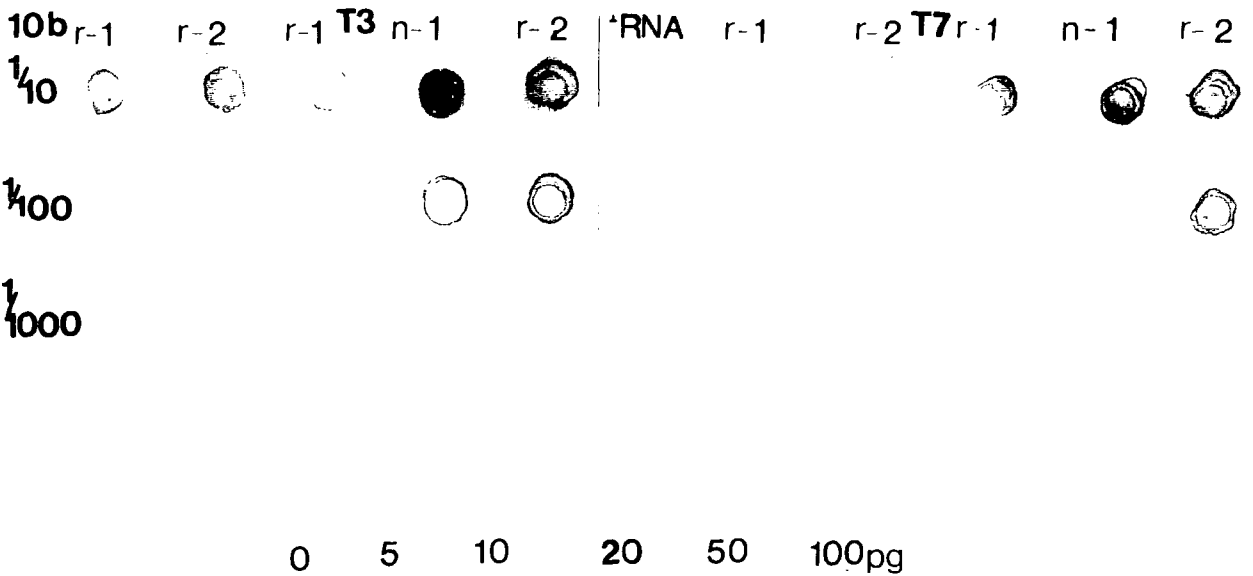

and Singer (1987) used ^{32}P radiolabelled probes successfully, and Schmelzer *et al.* (1988) utilised ^3H -labelled RNA probes. Mouras *et al.* (1989) used both tritiated and biotin 11-dUTP labels; they reported that the tritiated probes resulted in a higher level of labelling than the probes labelled by biotin incorporation. However, Arakaki *et al.* (1988) suggested the use of radiolabelled probes should be restricted to specialized laboratories with the necessary equipment to cope with the safety problems encountered with the use of radiolabelled probes for *in situ* hybridizations.

Gebeyehu *et al.* (1987) reported the usefulness of biotin probes for *in situ* hybridizations. Cunningham *et al.* (1985) compared ^{32}P -labelled probes with biotin-labelled RNA probes and found biotin probes, at least as specific and as good as radiolabelled probes. Larsson *et al.* (1988) reported that ^{32}P -labelled probes did not give sufficient cellular definition and suggested, that the precision of alkaline phosphatase detection, and hence the detection utility was far better than autoradiographic detection even with the most precise ^3H isotope. They also suggested that the detection methods used with biotin, resulted in no background, whilst radiolabelled probes always left a low level of background. Guitteny *et al.* (1988) similarly suggested that the histological and subcellular resolution was greatly enhanced with biotinylated probes. Syrjanen *et al.* (1988) suggested that biotin probes were preferable to ^{35}S -labelled probes. McFadden *et al.* (1988) also demonstrated that this non-radioactive labelling gave superior resolution to radiolabelled probes and was therefore much better suited to electron microscope techniques.

Perrot-Rechanman *et al.* (1989) obtained initial *in situ*

hybridization results using a biotinylated probe, although they experienced problems with non-specific binding of streptavidin in some plant sections. As a result of this Perrot-Rechenman *et al.* (1989) used sulfonated cDNA probes which had been reported by Lebacqz *et al.* (1988) to be at least as sensitive as radiolabelled probes on filters.

In this project early work on root nodules using radiolabelled cDNA probes resulted in high levels of background, non-specific labelling, particularly around the amyloplasts possibly due to photographic emulsion becoming trapped in the sections, and a lack of sensitivity. Biotin-labelling proved to be more specific and precise, requiring less time to produce results, more economical and also allowed labelled probes to be stored for periods of up to six months before use.

Probes can be labelled with biotin by the incorporation of biotin-11-dUTP. (Harris and Croy, 1986) although McCracken (1986) demonstrated very low levels of RNA were obtained when this method of biotin incorporation was used.

Forster *et al.* (1985) reported a novel method of labelling probes, using photobiotin. McInnes *et al.* (1987) reported the successful use of photobiotin for labelling Southern, Northern and dot blots. Childs *et al.* (1987) used photobiotinylated probes for *in situ* hybridizations (and simultaneous immunolabelling). They reported that the photolabelling resulted in minimal damage to the probe, and was equal or superior to those labelled by the incorporation of biotinylated nucleotides. Bresser *et al.* (1987) investigated methods to optimize the labelling of probes with photobiotin, and reported that the use of photobiotinylated probes, instead of 11-dUTP biotin incorporation,

increased the sensitivity of *in situ* hybridizations by 2-3 fold.

In this work the use of photobiotin, as outlined in section Chapter 2.2.1.2. provided a sensitive, successful and reproducible method for labelling RNA probes.

A typical probe detection strip of biotinylated RNA probes compared with quantified standards, is shown in Plate 10b. This 'detection strip' technique was used to provide a guide to the degree of biotin-labelling of each probe.

4.2.2. Hybridization Pretreatments

Careful pretreatment of both slides and sections was found to be extremely important in this research. The introduction of RNA probes, which are less stable than DNA and more susceptible to very abundant RNases, meant that care with the slides used for the hybridizations was very important.

Slides and sections were handled throughout with gloves, and all solutions used were DEPC-treated to eliminate any RNase activity. All glassware used up to and during the hybridization, was treated with 5% hydrogen peroxide solution, followed by DEPC-treated sterile distilled water.

Initial problems, of keeping sections stuck onto slides throughout the hybridization and subsequent washes and detections, were overcome by the use of a 2% gelatine solution as described in Chapter 2.1.4. Other slide fixatives such as poly-L-lysine, and poly-vinyl-alcohol-vinyltriethoxysilane, either failed to hold sections on the slides, or produced unacceptably high levels of background. The time for which sections were allowed to dry down on 'subbed slides' was found to be an

important factor in retaining sections. McFadden *et al.* (1988) and Perrot-Rechenmann *et al.* (1989) also reported the importance of drying sections on slides before pretreatments and hybridization.

Brahic and Haase (1978) and Mouras *et al.* (1987) found that the initial 'blocking' of slides was an important step, whilst Singer *et al.* (1986) and Goldberg (1986) used acetic anhydride treatments to reduce non-specific background on slides. Neither of these two treatments were found necessary in my studies. Bresser *et al.* (1987) suggested that no particular fixed prehybridization step was necessary, and that blocking of non-specific binding of the probe and facilitating probe entry could be accomplished in the hybridization solution.

In this work experiments with pretreatments for *in situ* hybridizations were carried out to test a wide range of techniques. These ranged from no pretreatments at all, to lengthy protocols which were tried in conjunction with various hybridization protocols until the optimum for root nodules, described in Chapter 2.3.3. was achieved. The optimum pretreatments as outlined in 2.3.3.1. were based on those of Schmelzer *et al.* (1988), Smith *et al.* (1987), Meyerowitz (1987), and Childs *et al.* (1987). During optimization work sections were stained for RNA after each pretreatment to ensure there was no significant RNA loss as a result of any particular treatment. Godard and Jones (1978) suggested that HCl treatment of sections resulted in the loss of RNA, although no significant loss was observed in root nodule tissue, tested in this way. McFadden *et al.* (1988) also used hybridization pretreatments initially, but later dropped them suggesting that the necessary blocking steps could be accomplished in the hybridization.

Larsson *et al.* (1988) demonstrated that proteinase K pretreatment of sections resulted in a considerably enhanced signal however, as reported by Brigati *et al.* (1983), over-digestion can result in a loss of RNA in the section. The inclusion of EDTA and a pre-digestion of the proteinase K, was found to be useful in eliminating the possibility of any contaminating RNases.

Singer *et al.* (1986), suggested that the dehydration of sections immediately prior to the hybridization step helped to solubilize lipids in the cell membrane and make cells more permeable to the probe. This step was also found to be beneficial in this work with root nodules.

4.2.3. Hybridization Conditions

Following the pretreatments, the hybridization, based on methods used by Brahic and Haase (1978), Childs *et al.* (1987), Bresser *et al.* (1987), Smith *et al.* (1987), Meyerowitz (1987), Goldberg (1986), and Schmelzer *et al.* (1988), was carried out as outlined in Chapter 2.3.3.2.

The pretreatment and siliconization of the coverslips used in the hybridization was found to be important, as was the inclusion of dextran sulphate in the hybridization solution. Dextran sulphate was first reported by Wahl *et al.* (1979) to increase the speed and efficiency of hybridization. Hafen *et al.* (1983) reported that the inclusion of 10% dextran sulphate produced a four fold increase in the signal detection sensitivity of *in situ* hybridization studies.

Although yeast tRNA was successfully used in this work, Cox *et al.* (1984) had suggested that the inclusion of a carrier such as yeast transfer RNA (tRNA) had very little effect on the efficiency of *in situ*

hybridization.

Mouras *et al.* (1987) used 12-20 ng probe per slide, and reported that the quantity of probe, assuming it was in excess of the message to be detected, was not critical. Approximately 8 ng of probe per slide was found the most effective in this work with root nodules.

4.2.4. Post-Hybridization Washes

Post-hybridization washes were carried out according to the degree of stringency required to get repeatable and reliable results, with the sense strand hybridizations clean and the anti-sense producing a specific and repeatable pattern of labelling.

One of the advantages of RNA probes is the use of RNase A after the hybridization; this precludes the potential amplification of signals by hyperpolymer formation on target RNAs and reduces non-specific background. The use of S1 nuclease with cDNA probes is also possible, although Godard (1983) reported that high concentrations of S1 nuclease may lead to relocalization of the probes bound *in situ*.

Bresser *et al.* (1987) suggested that the delaying of post-hybridization washing beyond the first incubation with streptavidin, thus eliminated the re-blocking step between the washes and the detection; this procedure was not tried in this work.

4.2.5. Methods of Probe Detection

Early experiments with the streptavidin biotinylated-peroxidase (ABC) detection system, used by Childs *et al.* (1987) did not prove as successful as the streptavidin-biotinylated-alkaline phosphatase, system which was detected by 5-bromo-4-chloro-3-indolyl phosphate

(BCIP) and nitroblue tetrazolium (NBT) to produce a purple precipitate (Leary *et al.* (1983). This system has been effectively used for the detection of biotinylated probes hybridized *in situ* in many instances (e.g. Arakaki *et al.*, 1988; Larsson *et al.*, 1988).

Although this detection method produced reliable and reproducible results, the blue precipitate was not always clearly distinguishable on 10 μ m root nodule sections. In an attempt to clarify this labelling, detection methods utilizing protein A-gold and silver enhancement methods were also used.

From the detection methods outlined on the following page, method 3 produced significant quantities of non-specific background; this was possibly due to the omission of the streptavidin in some experiments which has a very high affinity for biotin, and incubations with antibodies which are liable to bind non-specifically. Method 2, as demonstrated in Plates 16 and 18, gave some very specific results, but proved not to be quite so reliable and reproducible as method 1.

Detection Methods

1
|
STREPTAVIDIN
|
Biotin
|
Streptavidin
|
Biotin
|
alk. phos.
|
NBT/BCIP
|
blue ppt.

2
|
STREPTAVIDIN
|
Biotin
|
Streptavidin
|
gold
|
silver
|
enhanced

3
|
ANTI-BIOTIN
|
anti-biotin
|
IGG
|
goat anti-rabbit
|
gold
|
silver
|
enhanced

4.3. IMMUNOCYTOCHEMISTRY FOR PROTEIN LOCALIZATION

Immunocytochemical techniques previously established from this laboratory (e.g. Harris and Croy, 1985; Harris *et al.* 1989), provided a successful basis on which to carry out the protein localizations. Similar studies have been carried out by VandenBosch and Newcomb (1986), Sasakawa *et al.* (1988) and Vanden Bosch and Newcomb (1988) on legume root nodules. Several methods of antibody detection were used.

Antibody Detection

1	2
1 ^o antibody	1 ^o anti - body
goat, anti - rabbit gold	goat, anti - rabbit alkaline phosphayase
silver enhanced (for light microscopy).	NBT/BCIP blue ppt.

The alkaline phosphatase visualisation method was used as a comparison with the silver labelling; results are presented in Chapter 3.3. The alkaline phosphatase method proved to be a rapid and reliable technique, and provided a basis on which to compare the silver and alkaline phosphatase detection methods used for the *in situ* hybridizations.

PEG 1000 was found the best embedding medium for immunocytochemistry at the light microscope level, although L.R. White sections were also used. L.R. White embedded material was used for the

immunolabelling at the electron microscope level. McFadden *et al.* (1988) suggested that the use of L.R. Gold for immunolabelling at the electron microscope level is possibly superior to L.R. White, although this has not been investigated here.

5. THE USE OF *in situ* HISTOCHEMICAL TECHNIQUES TO LOCALIZE GLUTAMINE
SYNTHETASE mRNA AND PROTEIN IN *Phaseolus vulgaris* ROOT NODULES

5.1. RESULTS

The results of the *in situ* hybridizations presented here demonstrate the location of the *gln- α* , *gln- β* and *gln- γ* mRNAs in developing *P. vulgaris* nodules (5.1.1), and the resultant protein levels detected by immunocytochemistry (5.1.2). These results are then discussed in relation to previous reports on the temporal and spatial regulation of glutamine synthetase polypeptides and isoenzymes in *P. vulgaris* (5.2).

5.1.1. The Localization of GS mRNA

The optimized *in situ* hybridization technique was used in conjunction with biotinylated cRNA probes as discussed in Chapter 4.

P. vulgaris nodule sections, hybridized with a biotinylated α RNA probe and visualized with alkaline phosphatase substrate to give the blue/purple colouration, are shown in Plate 11. This Plate demonstrates clearly that the *gln- α* mRNA is most abundant in the inner, mid and outer cortex, and the non-infected cells of the central region throughout nodulation.

In contrast, sections labelled with the β probe (Plate 12a-c) show heavy labelling throughout the nodule tissue in the early stages. However these levels decline rapidly with nodule maturity. The decrease in β mRNA is particularly marked in the infected cells of central

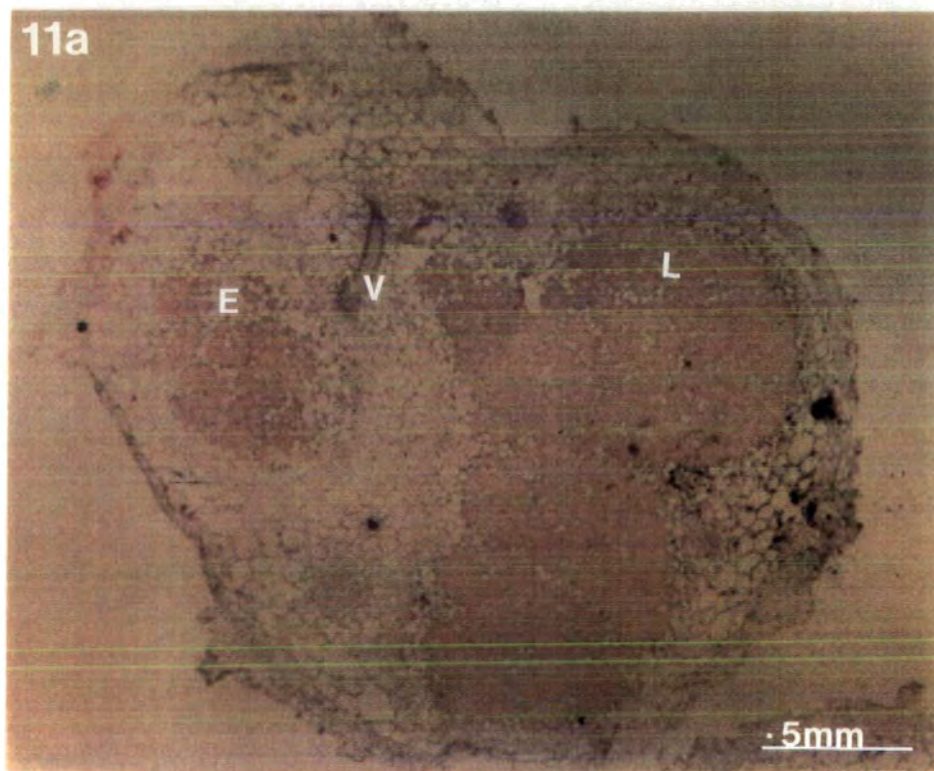

Plate 11 Sections hybridized with a biotinylated α probe, demonstrate the transcription of the α polypeptides is largely confined to the inner, mid and outer cortical regions in both the early (E), and late (L), stages, shown in Plate 11a, heavy labelling is also shown around the major vascular tissue, (V). At a higher magnification, Plate 11b, it can be seen that the labelling is concentrated in the root and nodule cortical tissue, and at a lower level in the non infected cells, of the central region.

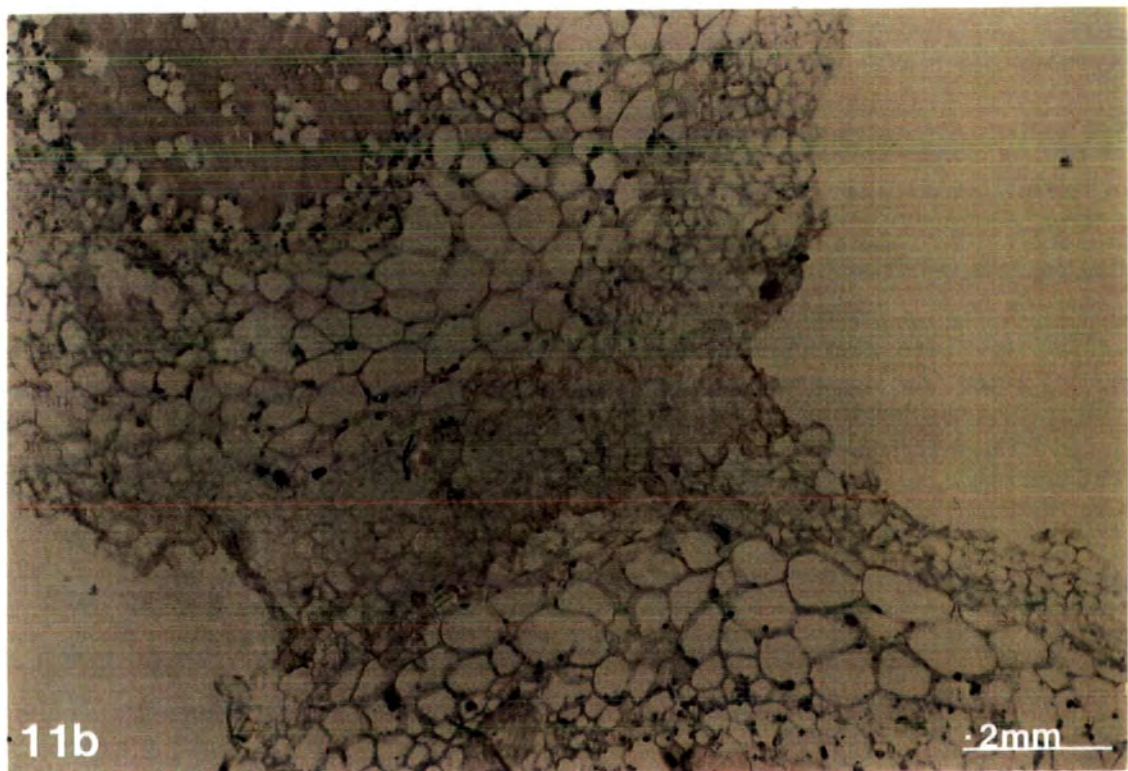
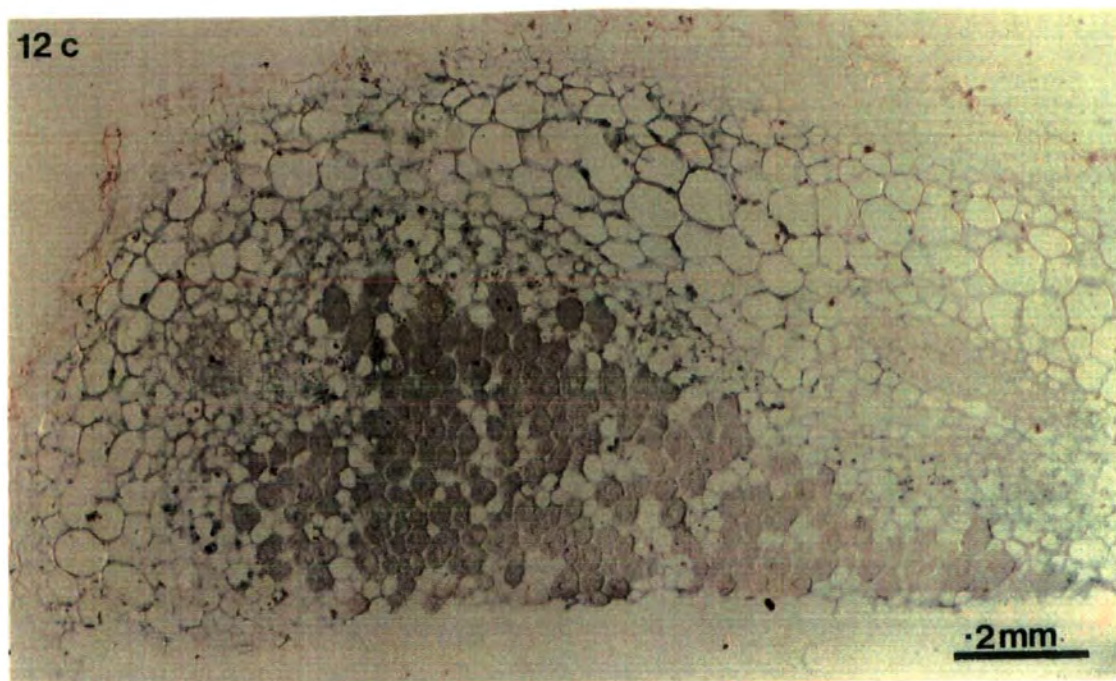
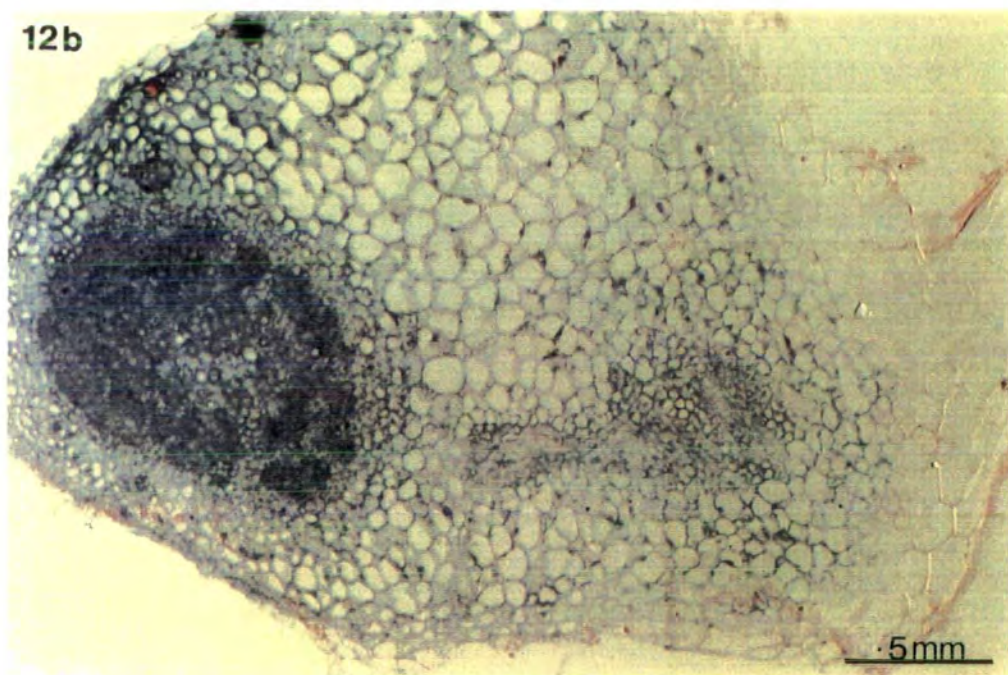
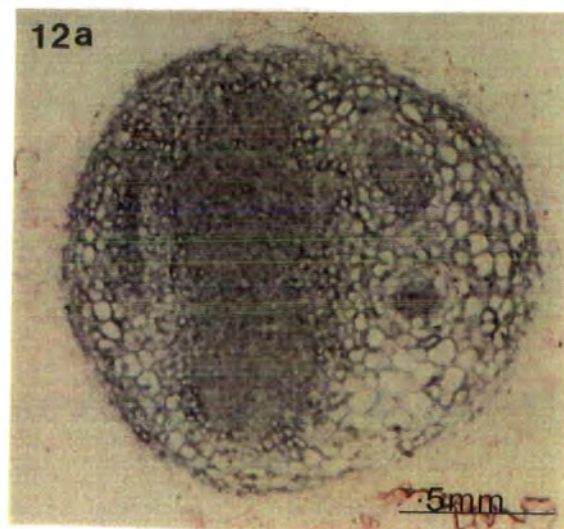

Plate 12 Early-mid
nodule sections hybridized
with a biotinylated β probe.
Plates a and b show heavy
labelling throughout,
particularly in the
infected cells. Plate 12c
shows a marked drop in the
level of expression of the
 β polypeptide, particularly
in the infected cells.



region, (Plate 13a). The highest level of expression becomes confined to the inner cortex, with the levels in the mid and outer cortical tissue remaining constant. High levels of accumulation are seen in the vascular endodermal cells of late nodules (Plate 13a). Control sections, hybridized with the biotinylated sense-strand of the β probe, demonstrate a very low level of background staining (Plates 14a and b).

Sections hybridized with the β probe, but visualized with the alternative streptavidin-gold and silver technique, show a similar pattern of labelling as seen with the alkaline phosphatase labelled sections (Plate 15). The β mRNA is present at high levels throughout the early nodule (Plate 15a), although this becomes predominantly confined to the inner, mid and outer cortical regions in the intermediate and late stage nodules (Plate 15b). Only a low level of β mRNA remains in the infected cells in a late stage nodule (Plate 15c).

The concentration of γ mRNA in the inner cortex and central, infected region in early nodules is demonstrated in Plate 16a. The labelling in the infected cells is evident when compared with a control section which was hybridized with a sense-strand γ probe (Plate 16b). The γ labelling becomes restricted to a band of cells in the inner cortex in a late stage nodule (Plate 16c).

A better illustration of the labelling in the infected cells is obtained when thicker sections are used (Plate 17), although the detailed morphology in these thicker sections is lost. A higher magnification of an intermediate stage nodule labelled with the γ probe (Plate 17b) illustrates the degree of γ labelling when compared with a control section hybridized with the γ sense-strand probe (Plate 17c). The alternative streptavidin-gold and silver detection method, used to

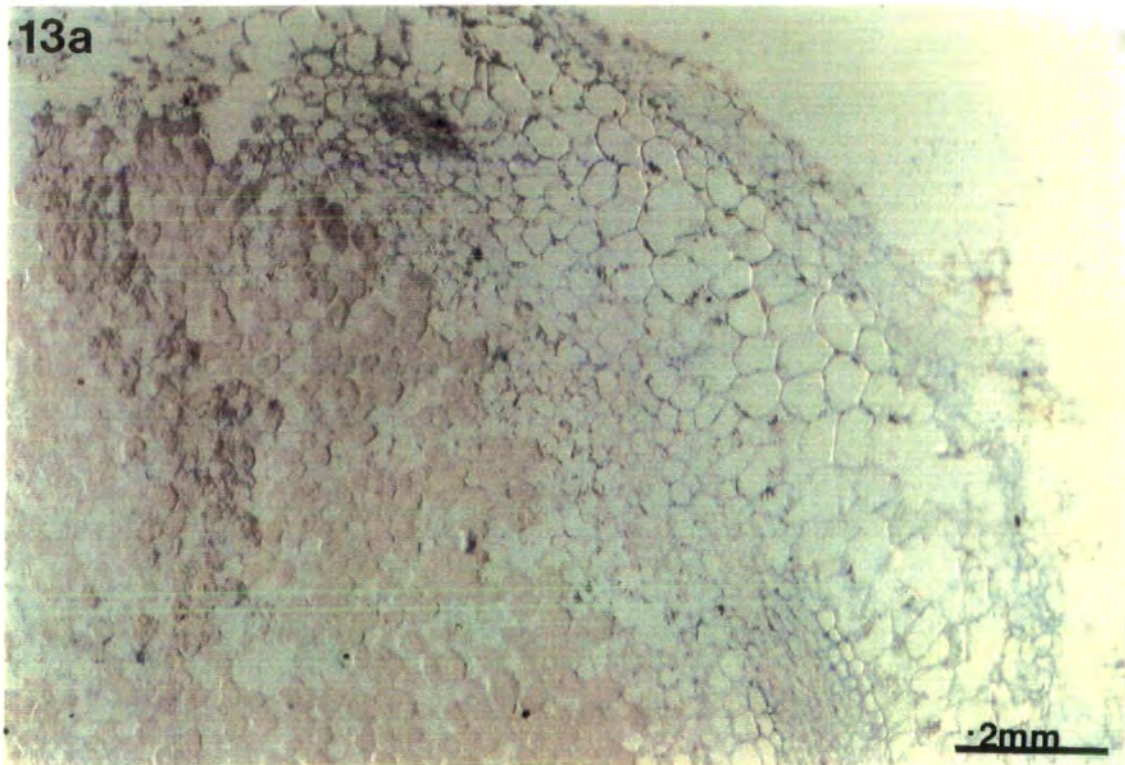
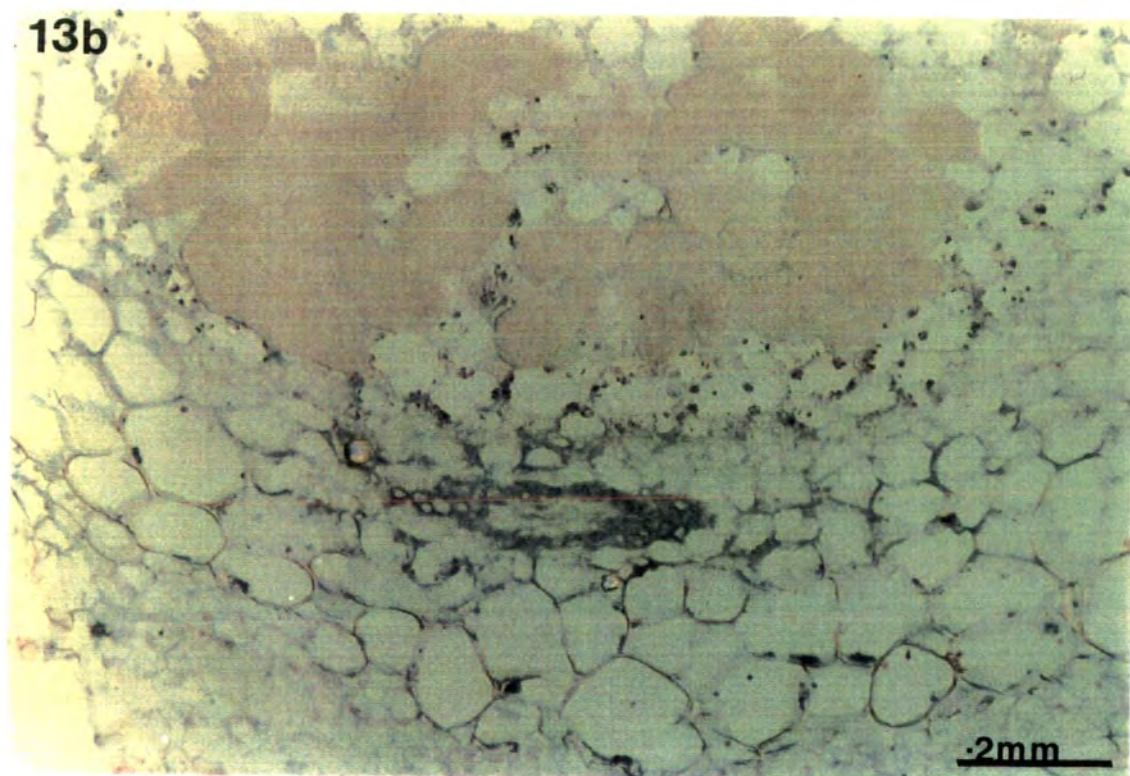

Plate 13 Mid stage nodule sections hybridized with a β probe demonstrate how the levels of β expression remain high in the nodule cortex, and particularly high in the vascular endodermis. Plate 13b shows the labelling in the central region is largely confined to the non infected cells at this stage.



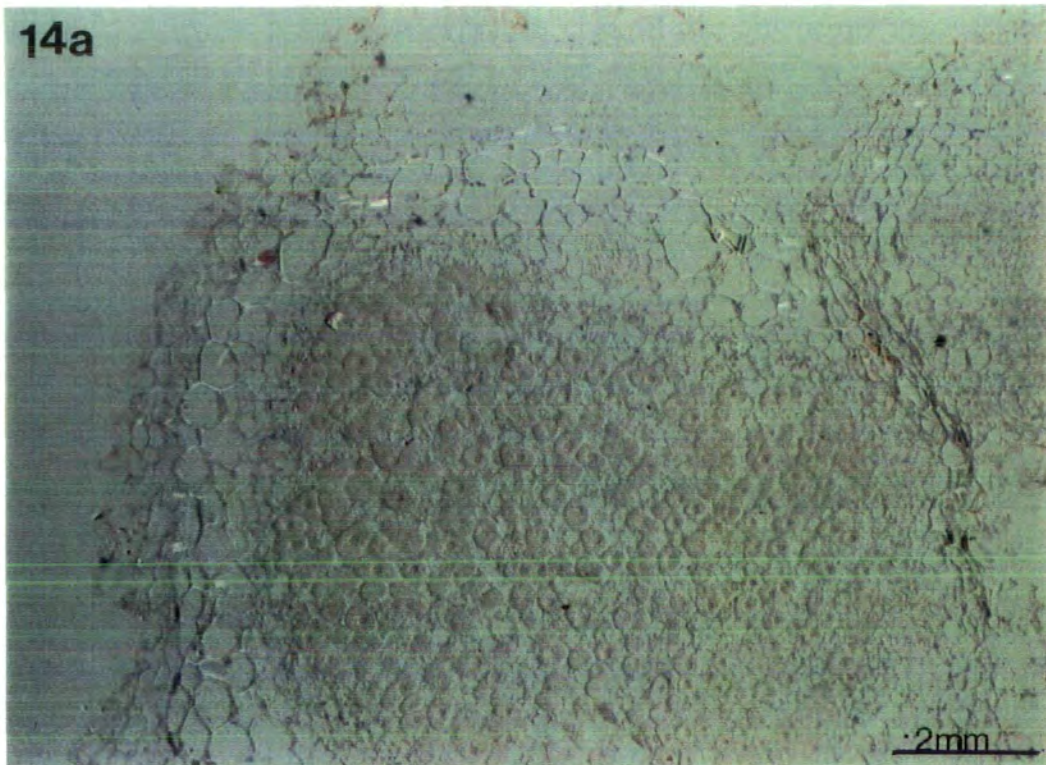
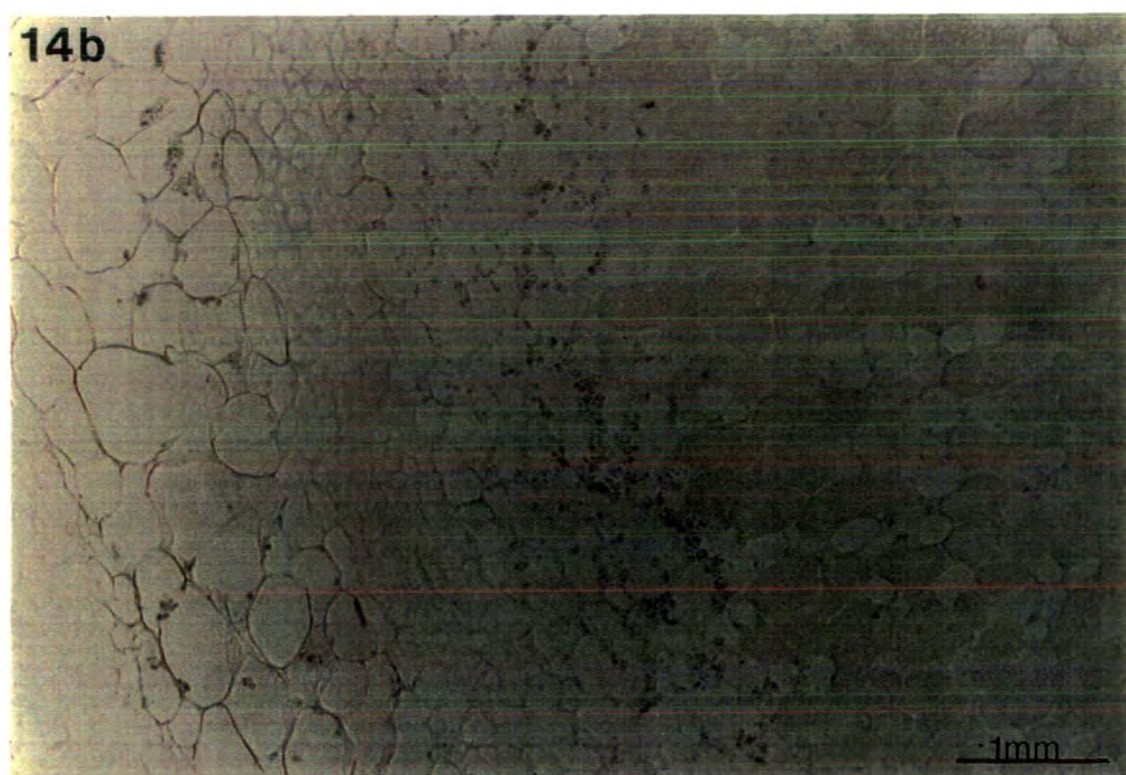

Plate 14 Control nodule sections hybridized with a biotinylated β sense strand probe and labelled with alkaline phosphatase.



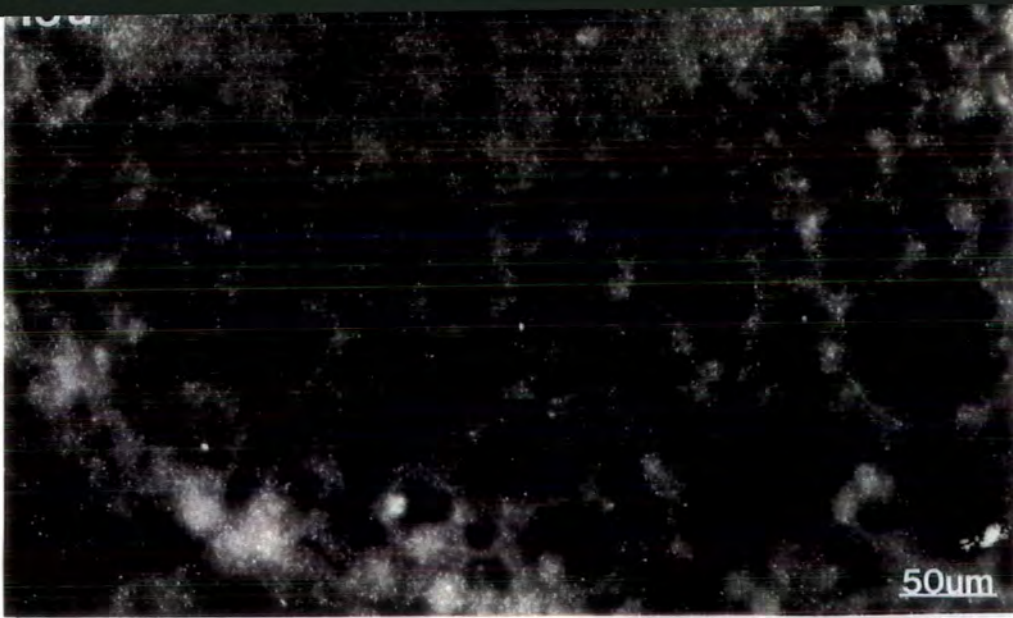
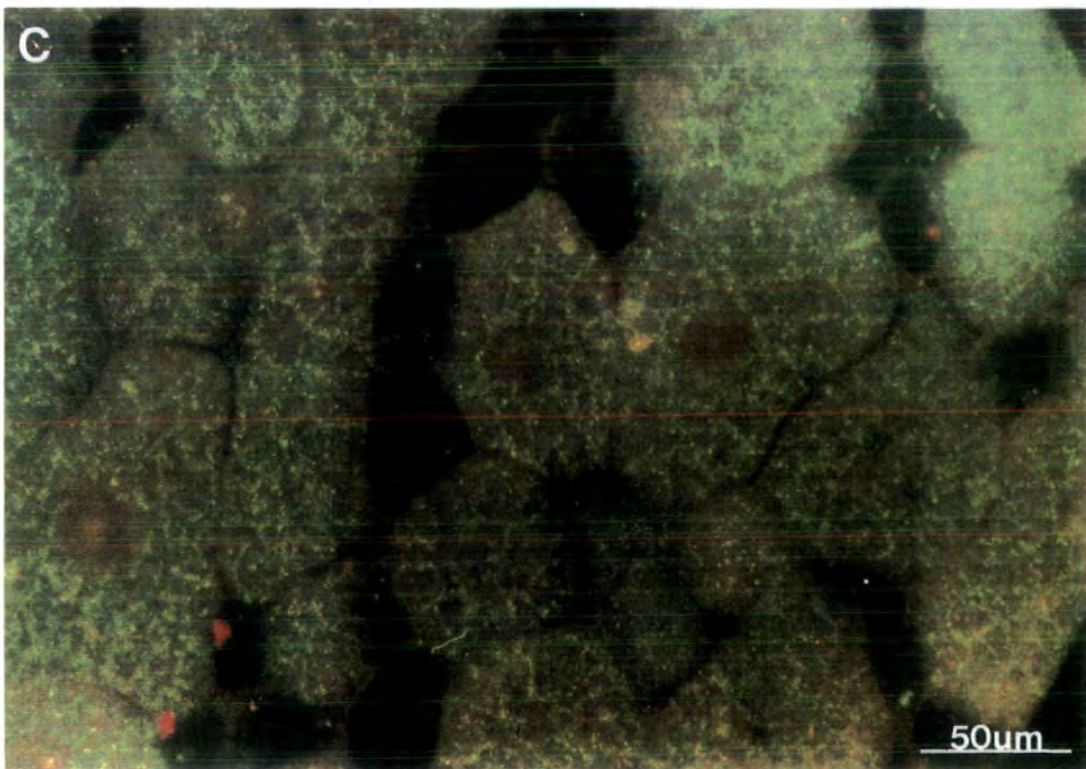
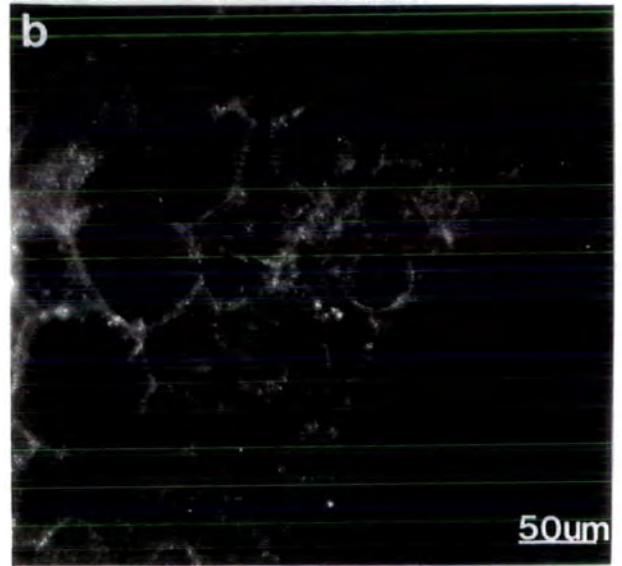

Plate 15 Early (a), mid (b), and late (c), sections hybridized with a biotinylated β probe detected by the alternative streptavidin gold and silver technique, demonstrates a high level of expression in the infected region of early nodules. This becomes confined to the outer cortex, with only a low level of detectable expression in the infected cells, Plates 15b and c.



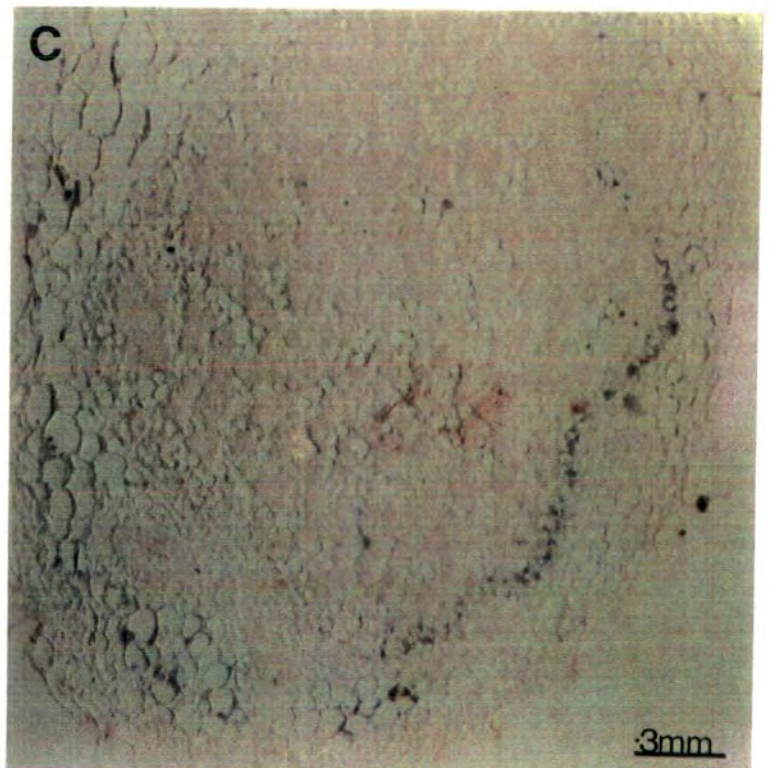
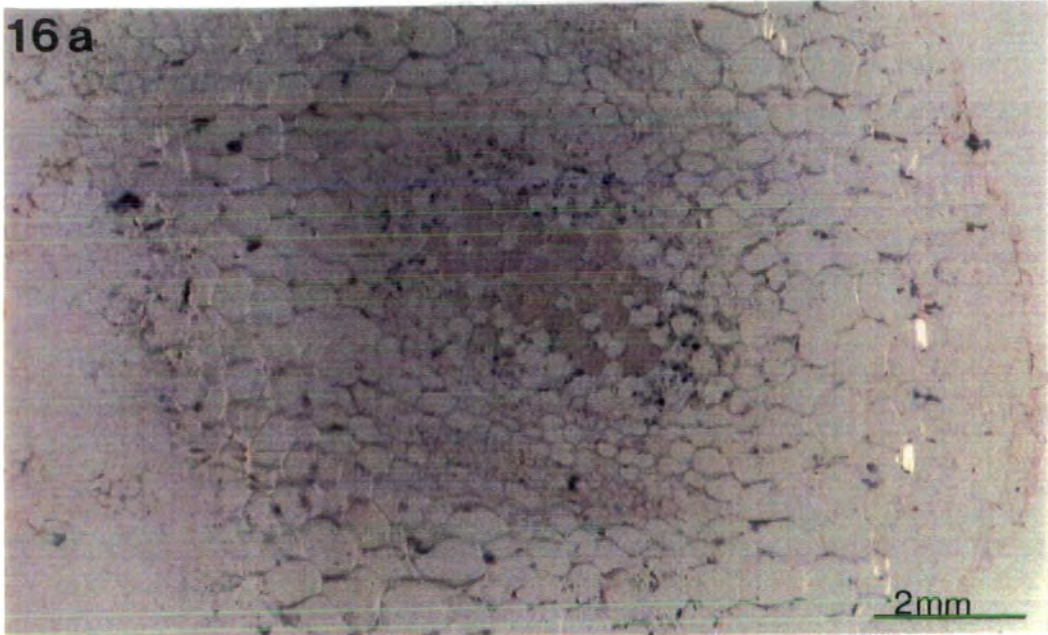

Plate 16, nodule sections hybridized with biotinylated γ probes, labelled with alkaline phosphatase, demonstrate the γ expression is predominantly confined to the inner cortical, and infected regions (a). Plate 16b, shows a control section hybridized with a sense strand γ probe. In late stage nodules the γ expression becomes confined to the inner cortex.

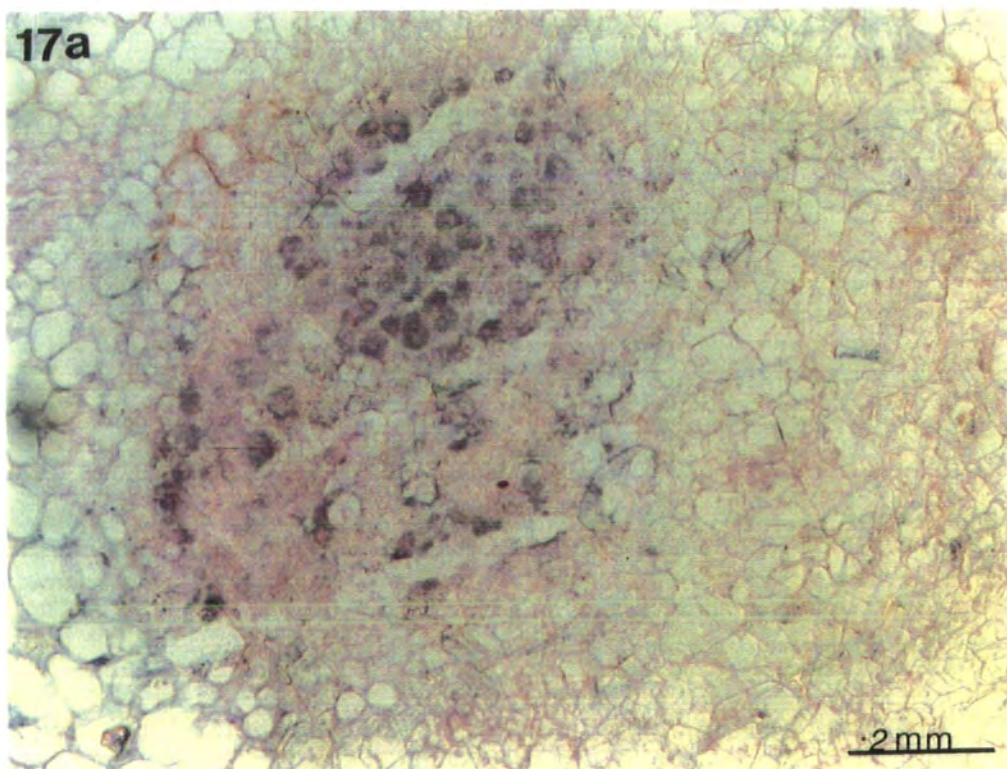
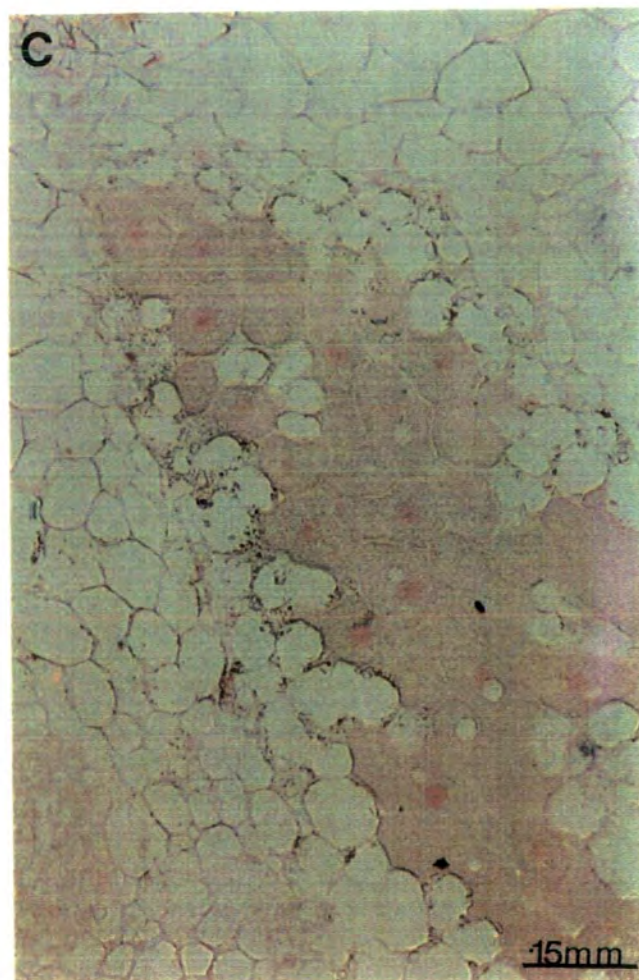
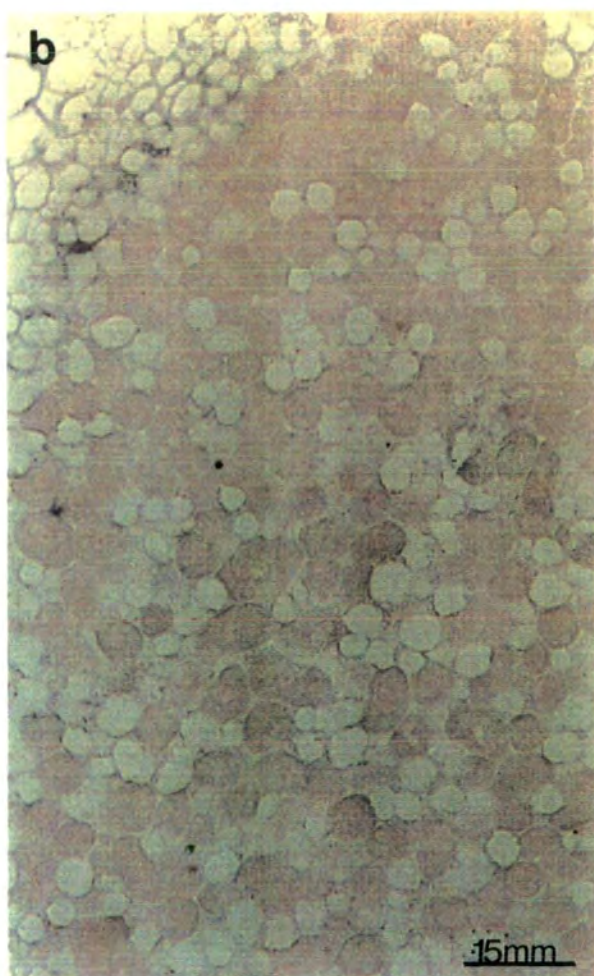

Plate 17 A thick section hybridized with the γ probe, demonstrates the heavy labelling in the infected cells of a young nodule (a), and labelling throughout the infected area and inner cortex. A normal ($10\mu\text{m}$) section, is demonstrated in Plate 17b, 17c shows a section hybridized with a control sense probe.



label the hybridized γ probe is demonstrated in Plate 18. This method again demonstrates the high level of γ expression in the infected, non-infected and inner cortical cells of the central infected region in an early nodule (Plate 18a), but subsequently becomes confined to the inner cortex as the nodule matures (Plate 18b). A higher magnification shows how the γ labelling becomes concentrated in the inner cortex in a late-stage nodule section (Plate 18c).

Table 6. Summary of the *in situ* hybridization results on *P. vulgaris* root nodules.

Developmental Stage	cell type	mRNA		
		α	β	γ
EARLY	I	-	++	++
	NI	+	++	++
	IC	++	++	++
	MC	+	+	-
	OC	+	+	-
	VE	++	++	-
MID	I	-	+	++
	NI	+	+	++
	IC	++	++	++
	MC	+	+	-
	OC	+	+	-
	VE	++	+	-
LATE	I	-	-	-
	NI	+	+	-
	IC	++	+	++
	MC	+	+	-
	OC	+	+	-
	VE	++	++	-

I - infected cells; NI - non-infected cells; IC - inner cortex; MC - mid cortex; OC - outer cortex; VE - vascular endodermis.

An intermediate stage nodule section hybridized with a biotinylated oligo-dT probe was used to demonstrate the major sites of transcriptional activity within the nodule (Plate 19a). The concentration of transcriptional activity around the vascular tissue was particularly evident in the intermediate and late stage sections (Plate 19b).

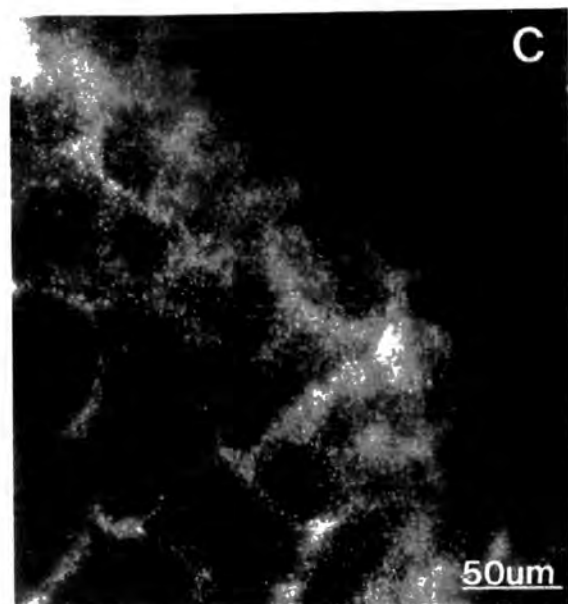
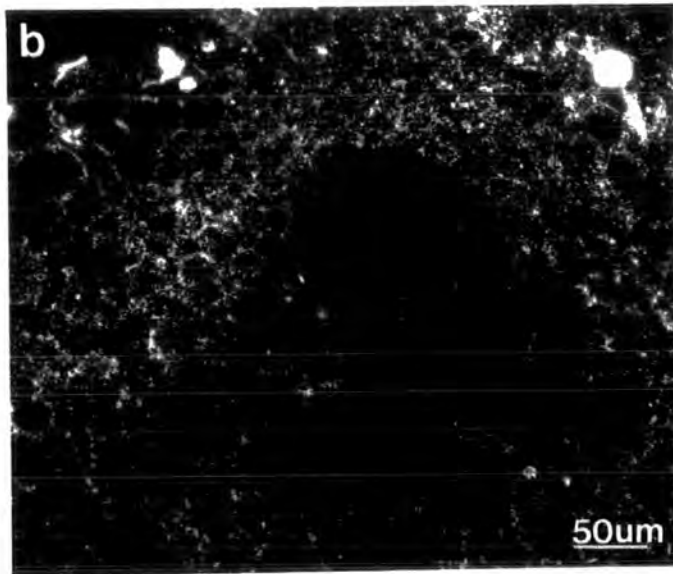
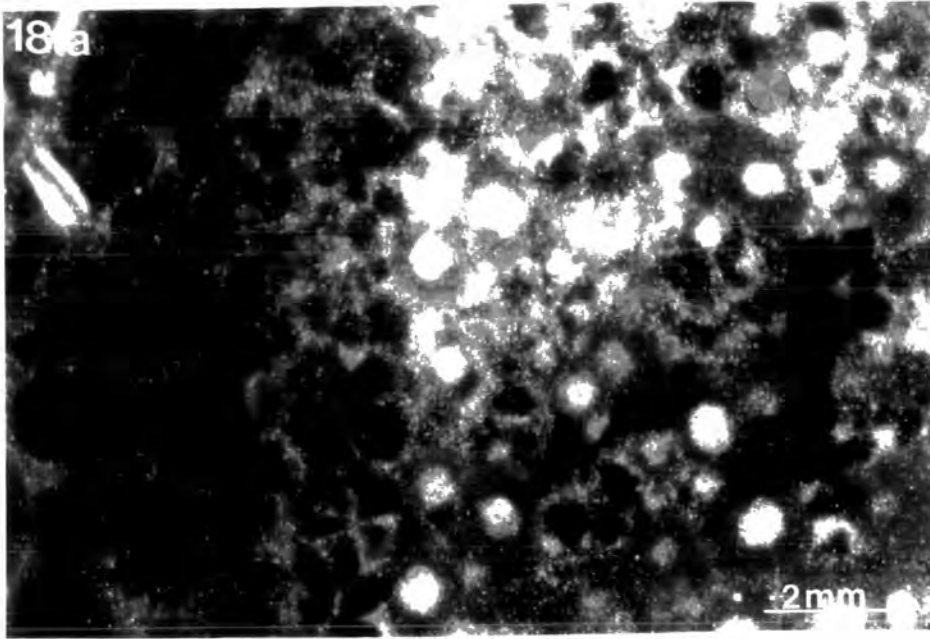

Plate 18, shows the alternative method of probe detection, using streptavidin gold enhanced with silver. The high level of labelling in 'a' is characteristic of the γ distribution in a young nodule, the labelling in the infected area and inner cortex becomes confined to the non infected cells, and the inner cortex, Plates 18b and c, in the later stages.

19a

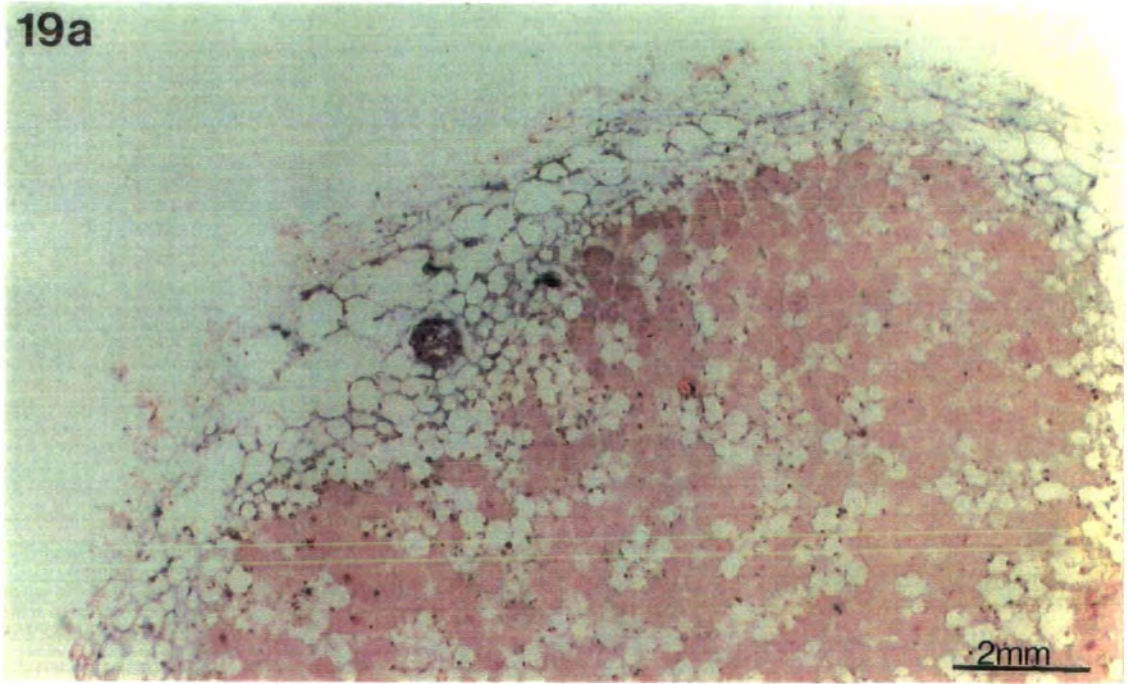
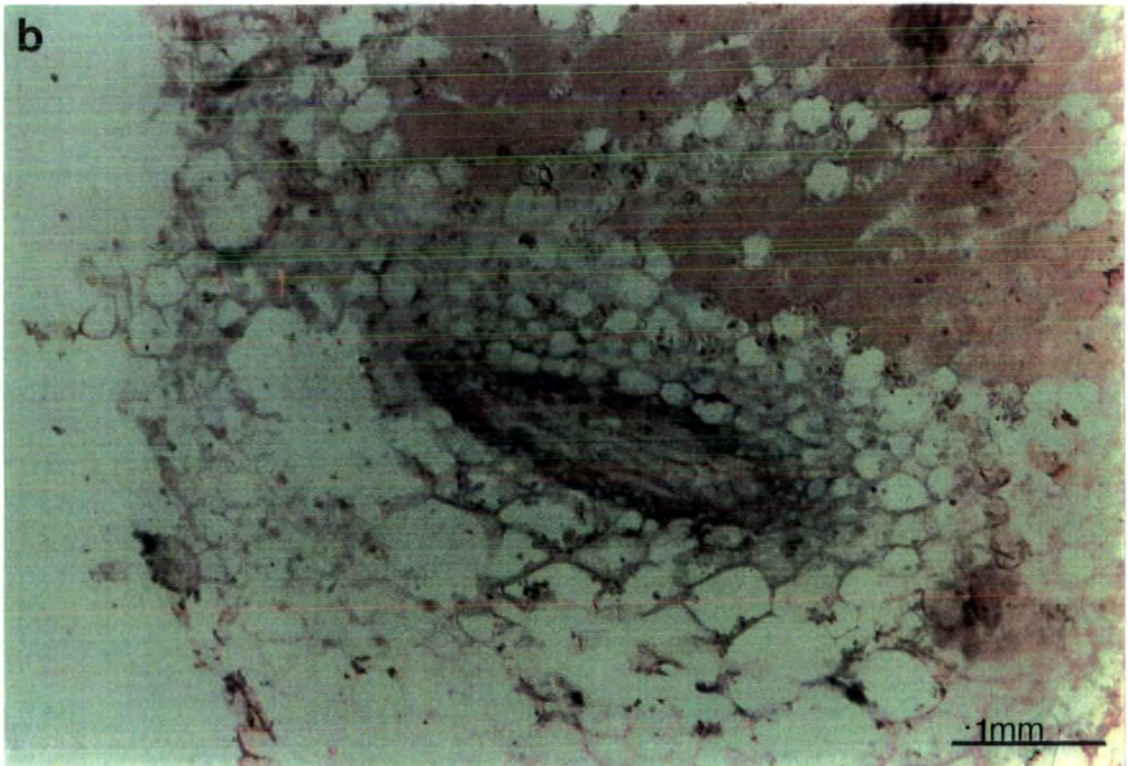

Plate 19 Sections hybridized with an oligo dT probe, demonstrate the regions of highest transcriptional activity. Plate 19a shows high levels in the inner and outer cortex, 'b' demonstrates the highest levels of transcriptional activity are in the vascular endodermal tissue in mature nodules.

b



5.1.2. The Immunocytochemical Localization of Glutamine Synthetase in *P. vulgaris* Root Nodules

The divergence of the GS genes, which has been discussed in Chapter 1, is largely confined to their flanking regions. The different mRNAs can therefore be distinguished using probes which correspond to these flanking regions. The antiserum raised to the isoenzymes is not, however, able to distinguish between polypeptides. Cullimore and Miflin (1983) demonstrated that this antiserum was able to recognise both cytosolic GS isoenzymes of *P. vulgaris*, GS₁₁ and GS₁₂. The immunolabelling methods used in this work therefore can only demonstrate total GS protein in nodules.

5.1.2.1. Immuno-gold Localization of GS protein

The distribution of GS, as demonstrated by immunocytochemistry in an early to intermediate stage nodule section, is shown in Plate 20. Specifically bound antibody is localized with a colloidal-gold secondary antibody, and enhanced with silver. Taking into account the differential distribution of cytoplasm GS appears to be relatively evenly distributed throughout the infected and non-infected cells, on a per cytoplasm basis but not per cell basis, of the central region of the nodule. High levels are also present in the inner and outer cortex, although the mid-cortex only has a low level. The vascular endodermis has relatively high levels, similar to that of the inner cortex, whilst the vascular bundles are themselves almost devoid of GS.

Very early nodules show high concentrations of GS in the developing central tissue. Two regions of early infection are shown in Plates 21a and b, the younger region, on the right hand side of the

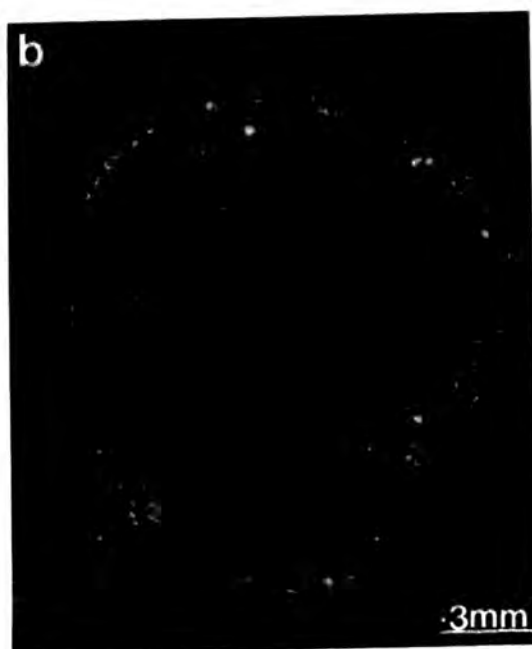
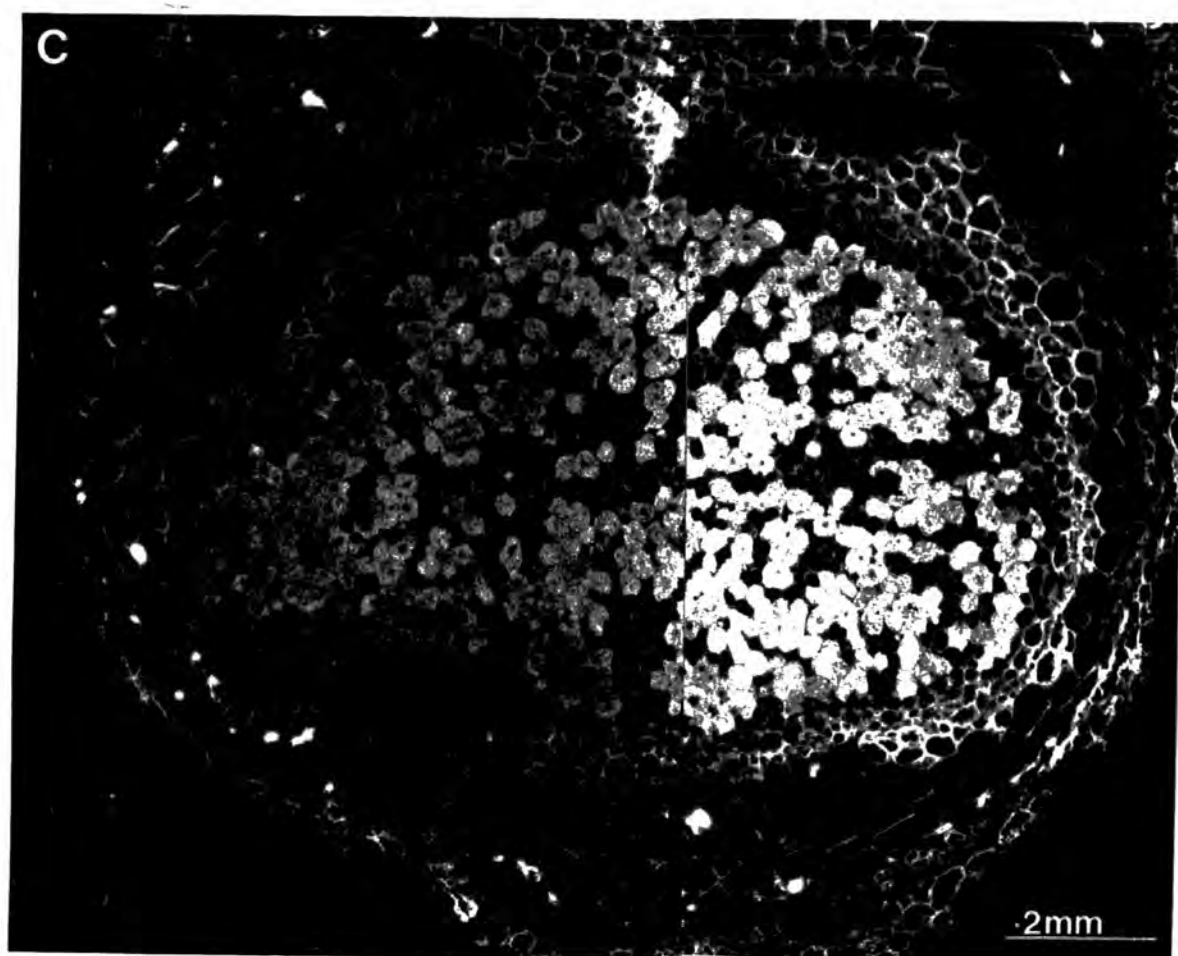

Plate 20. Early-mid stage *Phaseolus* section labelled with glutamine synthetase IgG, visualized with protein-gold and silver enhanced. Low magnification bright field (a), and dark field (b), demonstrate the distribution of labelling throughout the nodule. Plate 20c shows the concentration of labelling in the infected cells and particularly the inner cortex.



nodule, shows a significantly higher concentration of GS particularly in the developing inner and outer cortical tissue. The slightly older region has more labelling concentrated in the central, infected area, the mid-cortex has a relatively low level of labelling. The vascular endodermal tissue has similar levels to the inner cortex and the vascular bundles are again devoid of GS protein.

Control sections of *P. vulgaris* nodules treated with rabbit pre-immune serum, followed by the gold and silver detection method showed very little or no labelling (Plate 21c).

GS levels drop considerably in late stage nodules (Plate 22), and are almost absent in the inner cortex and some of the very elongate infected cells (Plate 22a). The GS protein becomes predominantly confined to the outer perimeter (the host cytoplasm) of the infected cells (Plate 22b). GS still remains in the vascular endodermal cells of late-stage nodules (Plate 22c).

5.1.2.2. Alkaline Phosphatase Visualization of GS Protein

As with the *in situ* hybridizations, in addition to the gold and silver detection method of visualization, an alkaline phosphatase detection method was used for the immunocytochemistry. The alkaline phosphatase method of GS protein visualisation shows a similar pattern of labelling to that shown with the silver; there is a particularly high level of labelling in the outer cortex, in early nodule sections, but to a lesser extent in the central infected region (Plate 23a). As found with the *in situ* hybridizations, a low level of alkaline phosphatase labelling is not so readily detectable as a low level of silver-enhanced gold. In intermediate stage nodules the labelling is



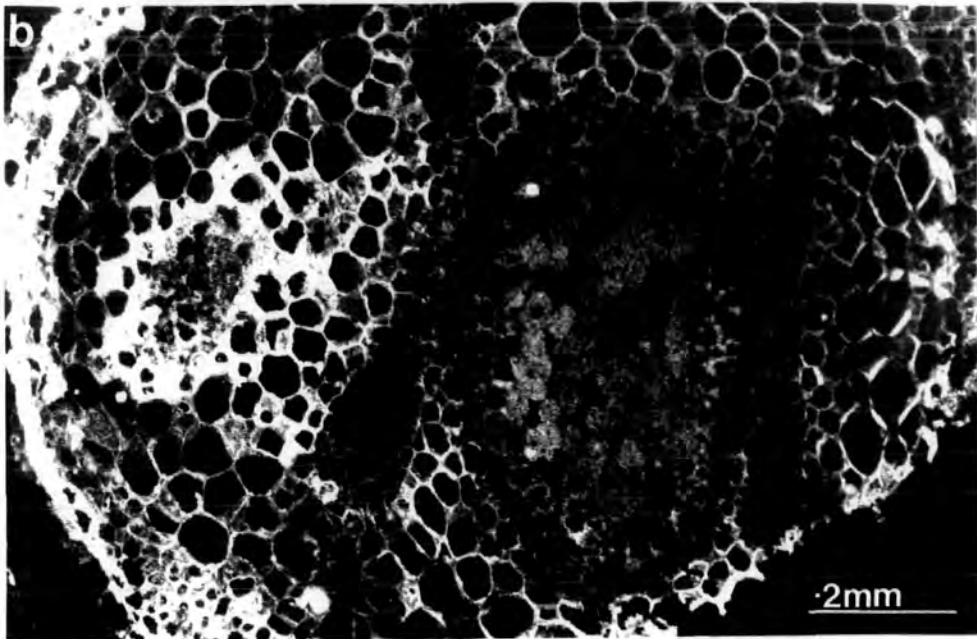
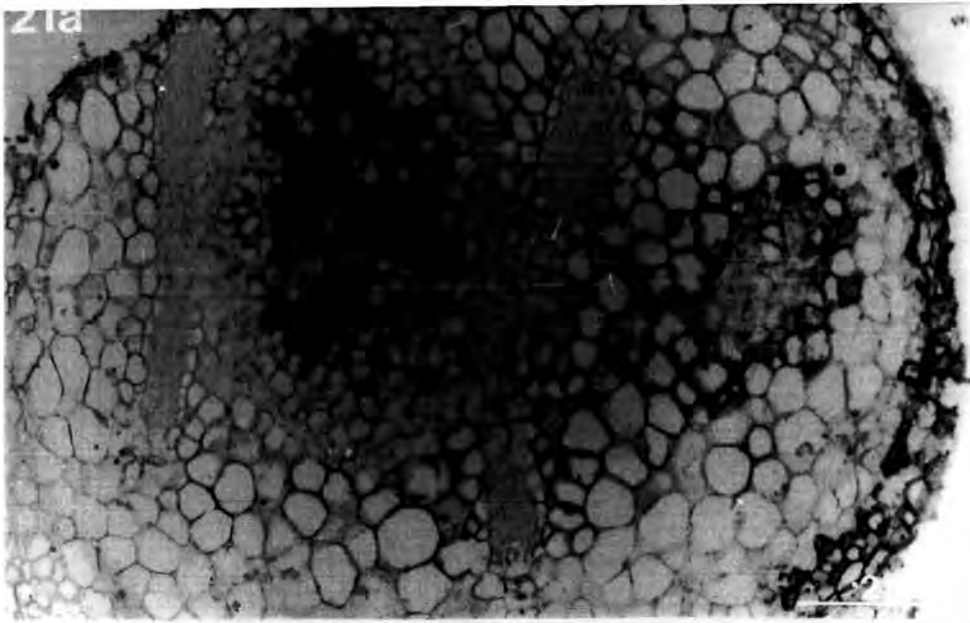
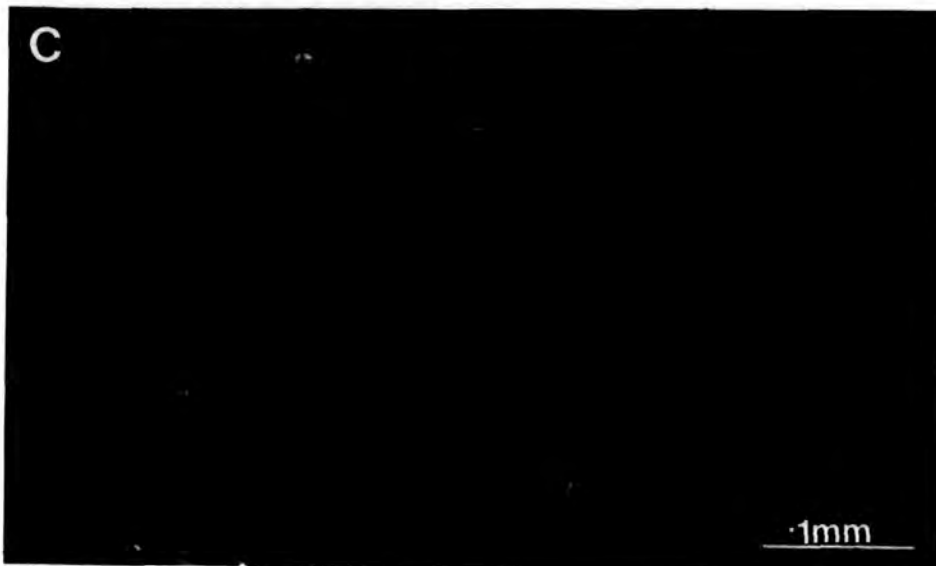

Plate 21. A bright field (a), and dark field (b), demonstrates the concentration of glutamine synthetase in the very early infected areas (I), and the lack of labelling on the vascular bundles (VB). Plate 21c shows a control section labelled with rabbit pre-immune serum.



22a

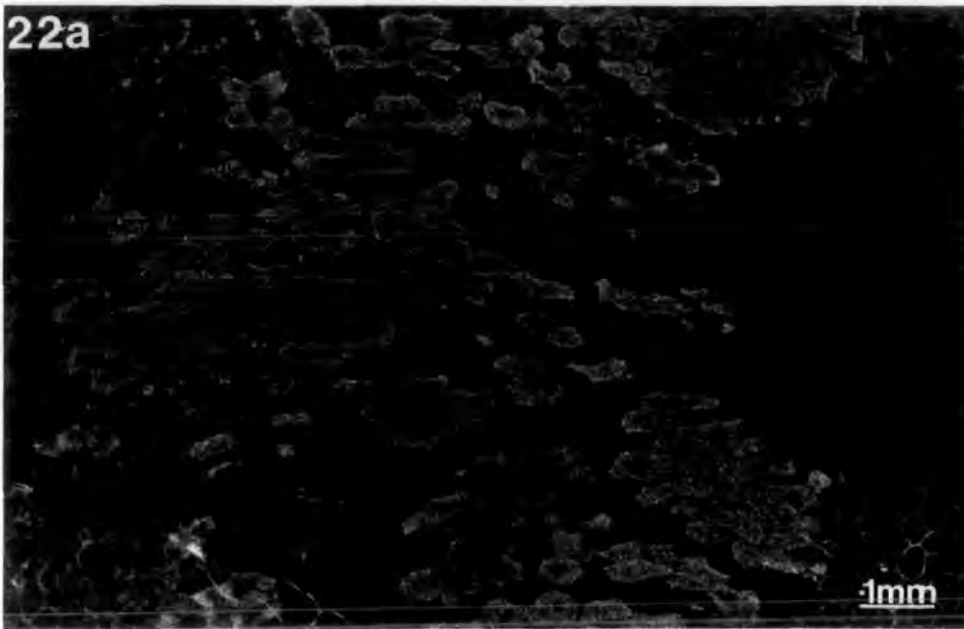
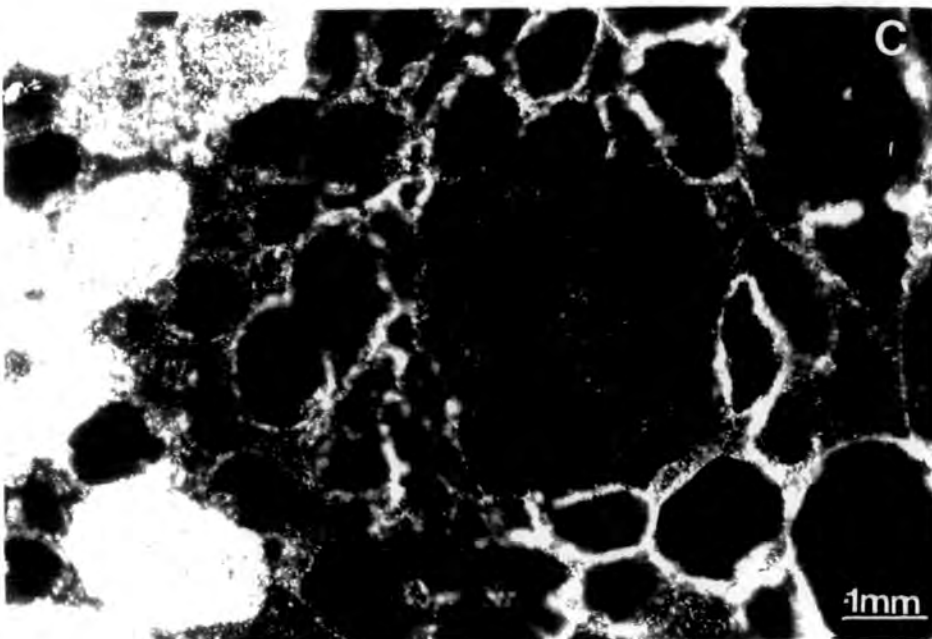
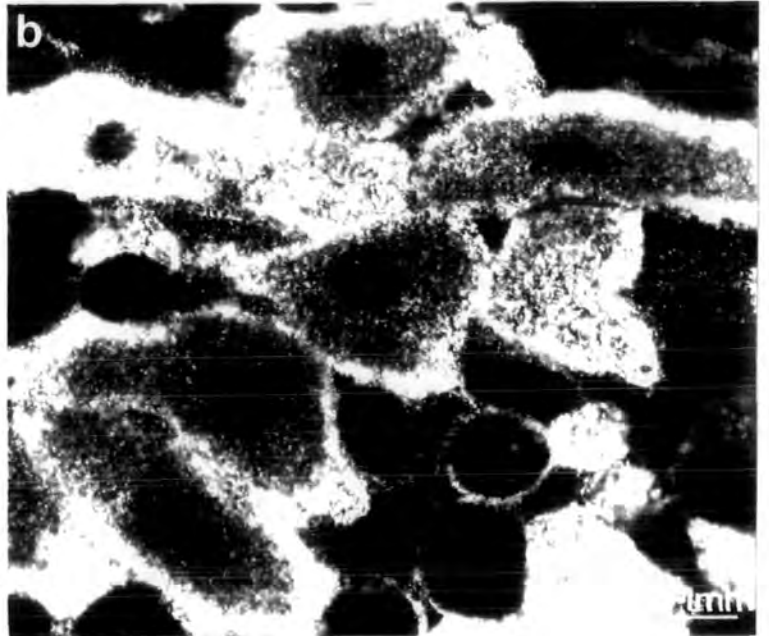

Plate 22 A section through a very late nodule, shows the drop in glutamine synthetase levels in the infected cells. At a higher magnification, the drop in glutamine synthetase can be localized to the centre of the infected cells (b). Plate 22c shows relatively high levels of glutamine synthetase remain in the vascular endodermis (VB) but not on the vascular bundles.



23a

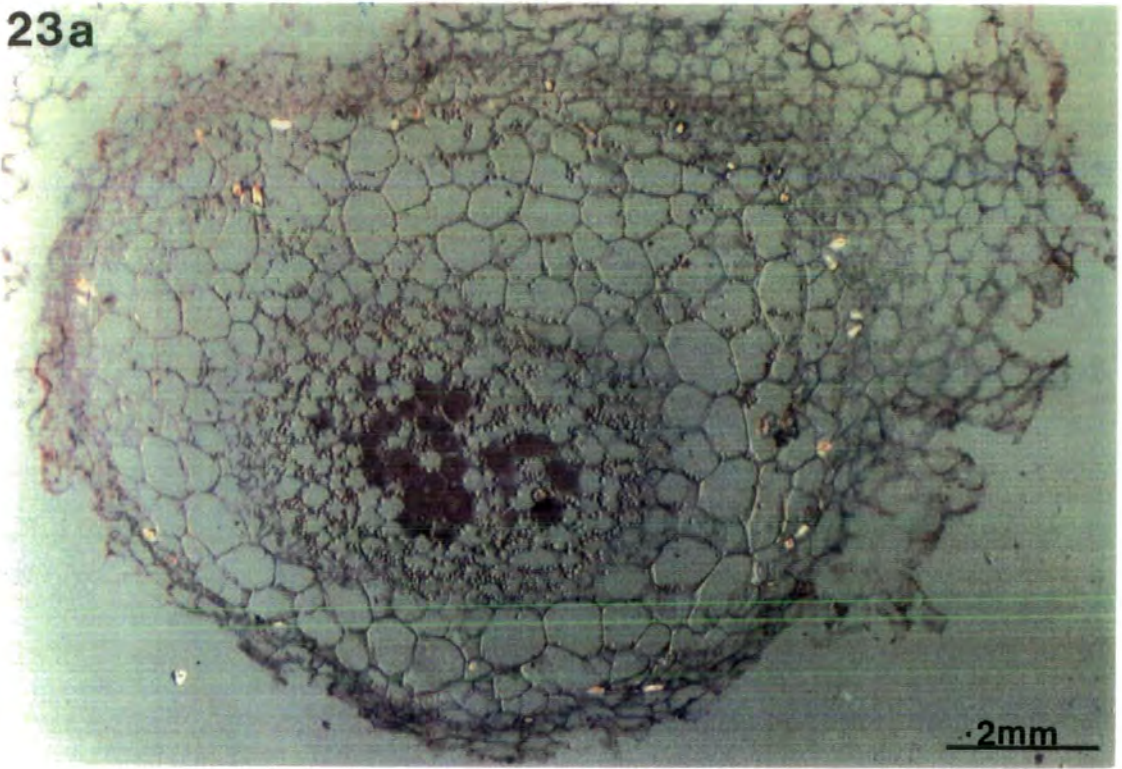
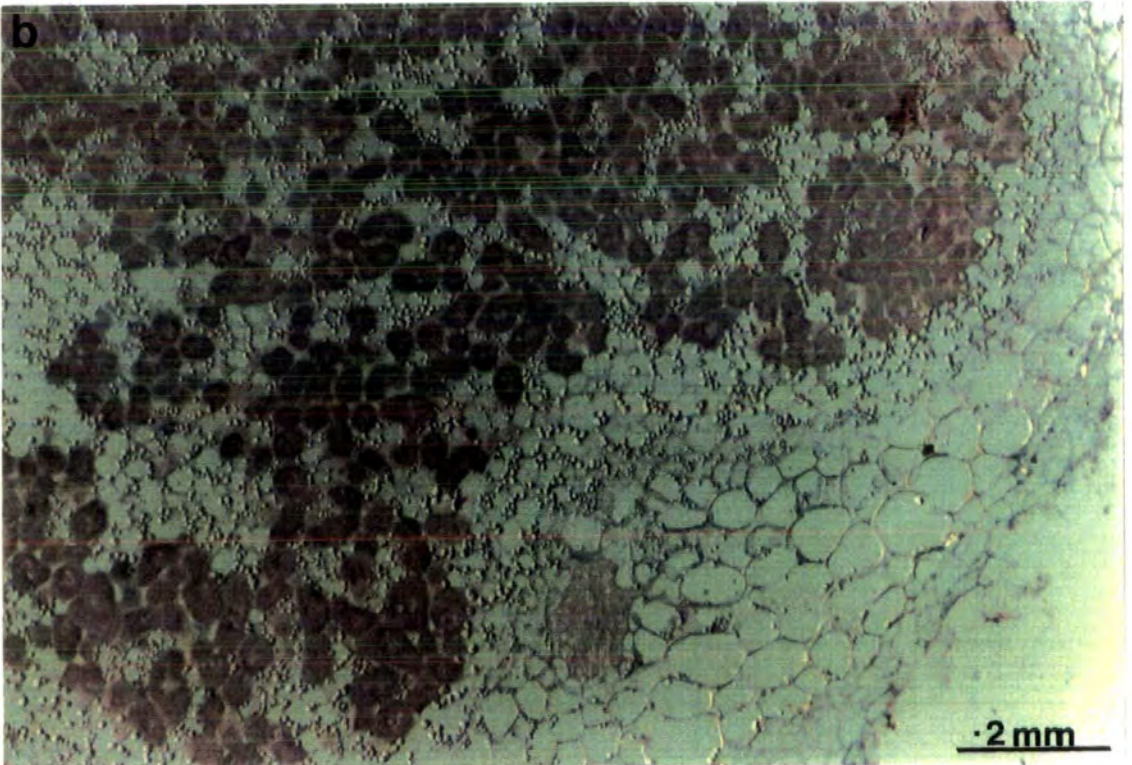

Plate 23. Sections labelled with glutamine synthetase IgG, visualized with alkaline phosphatase, demonstrate a similar distribution of glutamine synthetase as that shown by the silver in both early stage nodules (a), and mid stage nodules (b).



less apparent in the non-infected cells and inner cortex (Plate 23b) than was evident with the silver method (Plate 20c). A higher magnification of the infected cells of an intermediate stage nodule shows that the labelling of the non-infected cells is only detectable when closely compared with a control section treated with rabbit pre-immune serum (Plate 24c). Heavy labelling in the vascular endodermis, but very little in the vascular bundle, as demonstrated with the silver, is a common feature in sections of all stages (Plate 24b). GS becomes confined to the inner and outer cortical and vascular endodermal tissue, in late stage nodules and levels in the infected cells decline considerably (Plates 25a and b).

5.1.2.3. Immuno-gold Localization of GS Protein at the Electron Microscope level

A low magnification electron micrograph of the central infected region of an intermediate stage *P. vulgaris* nodule illustrates the distribution of infected and non-infected cells (Plate 26a). Immuno-gold localization of GS to the host cytoplasm of the infected cells is demonstrated in Plate 26b, with a lower level in the non-infected cells in Plate 26c.

5.1.3. Summary of Results Obtained by the *in situ* Localization of GS mRNA and Protein in *P. vulgaris* Root Nodules

Only the relative, rather than absolute, degree of labelling associated with each probe can be compared due to the differential size of probes. Although the experimental procedures used were designed to keep possible age and fixation variables to a minimum, their possible

24a

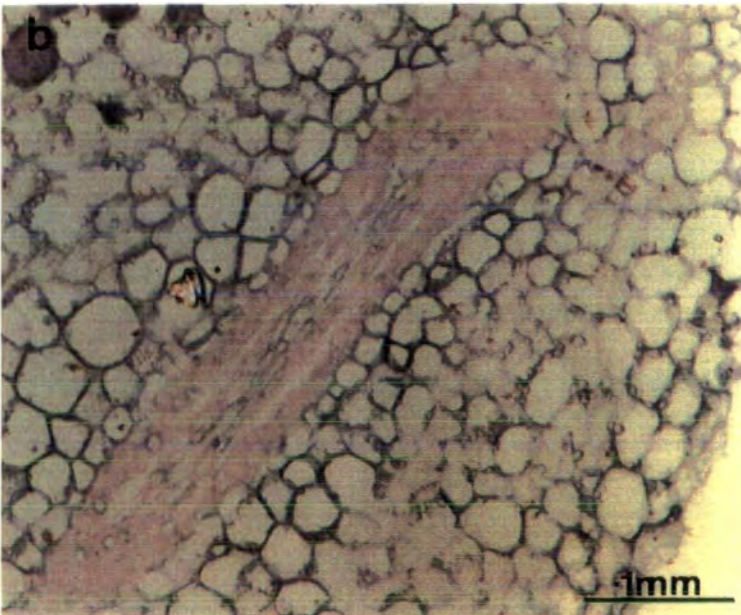
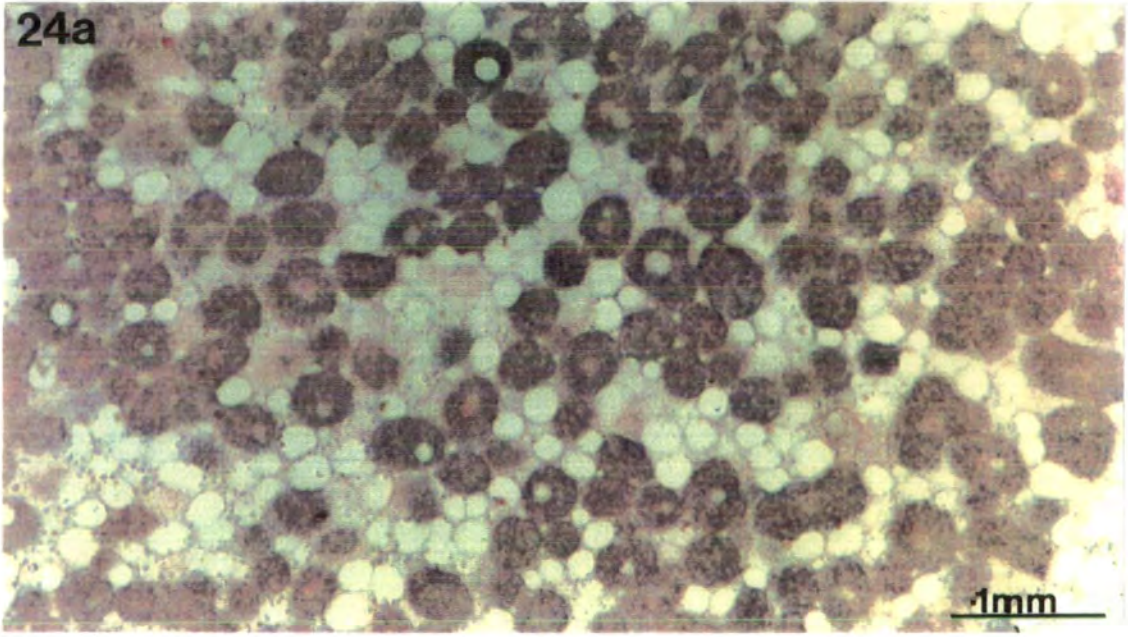
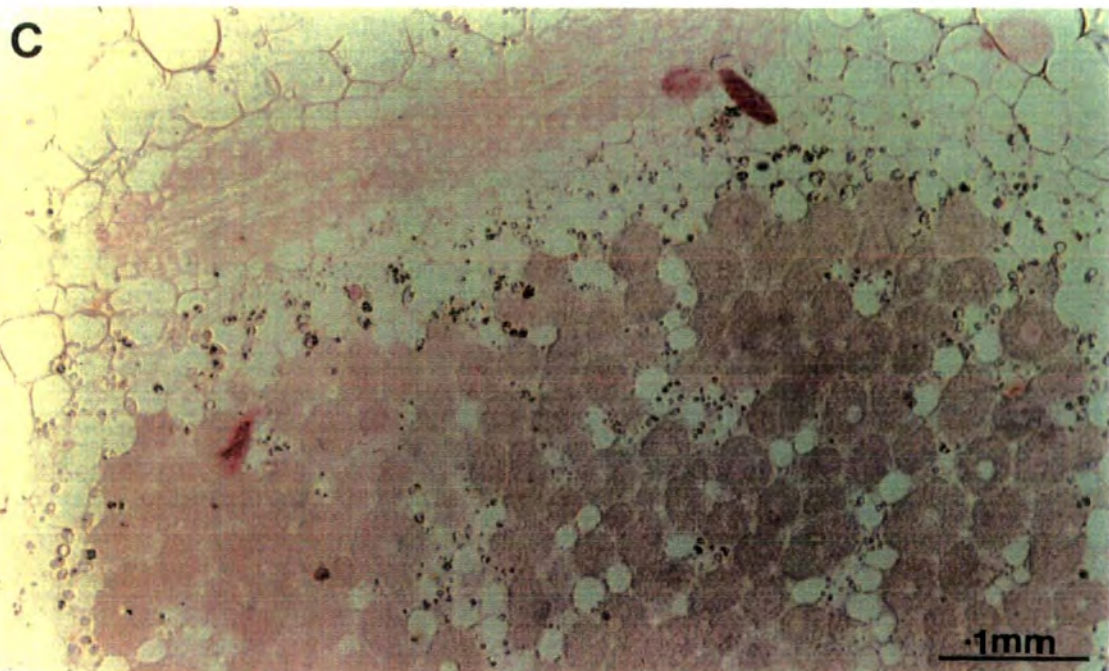

Plate 24 Sections labelled with glutamine synthetase IgG, and alkaline phosphatase, show high levels of labelling in the infected cells of a mid-stage nodule (a), and heavy labelling around the vascular bundles (b). Plate 24c shows a control section, incubated with rabbit pre-immune serum and labelled with alkaline phosphatase.



25a

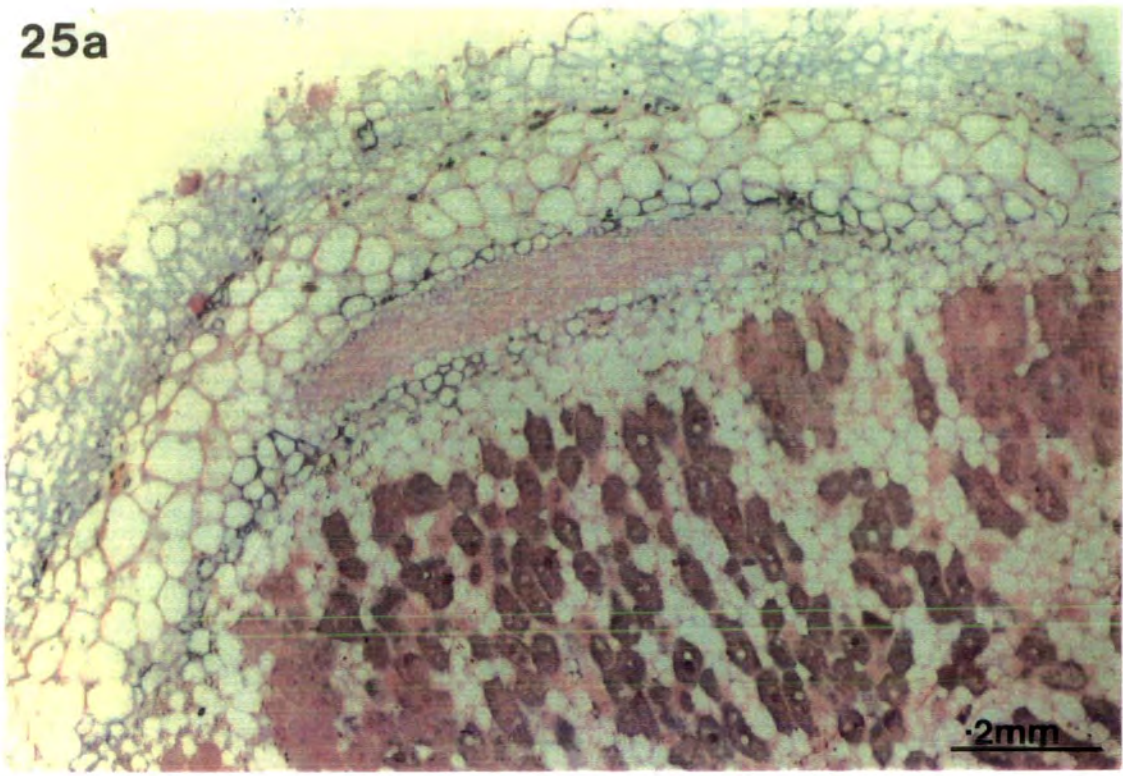
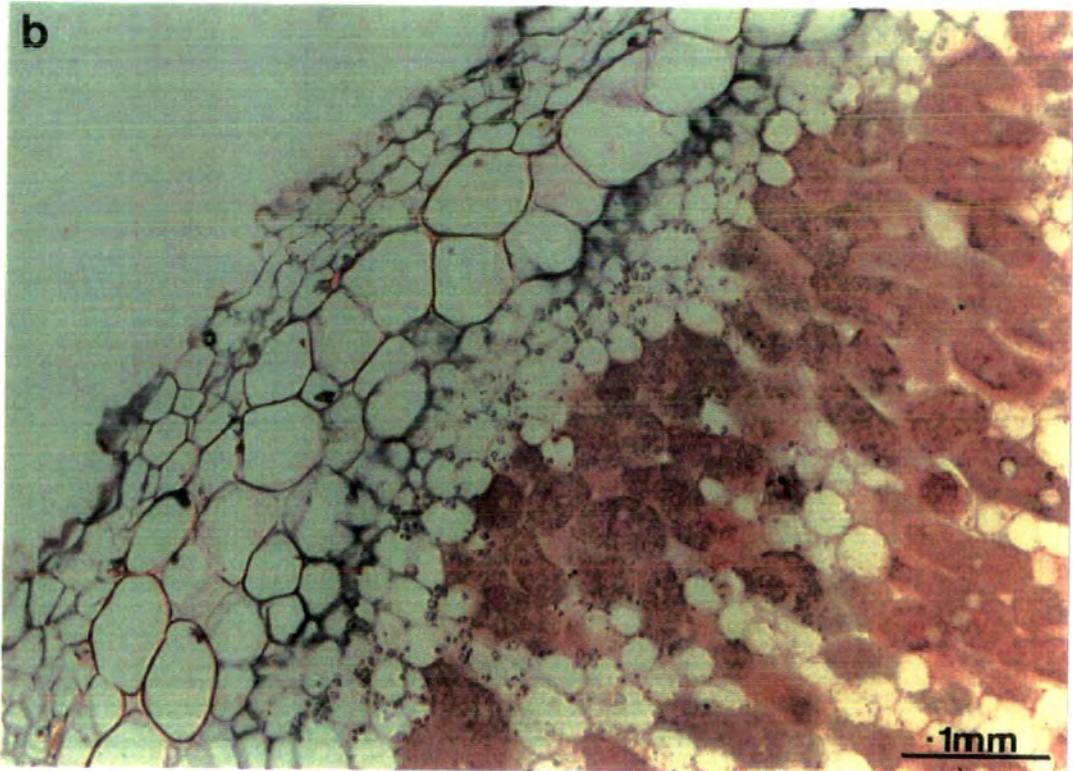

Plate 25. A late nodule section labelled with glutamine synthetase IgG, and alkaline phosphatase, demonstrates the high levels of glutamine synthetase around the vascular bundles. A higher magnification (b), shows a concentration of glutamine synthetase in the inner cortex, with lower levels in the non infected cells.



26a

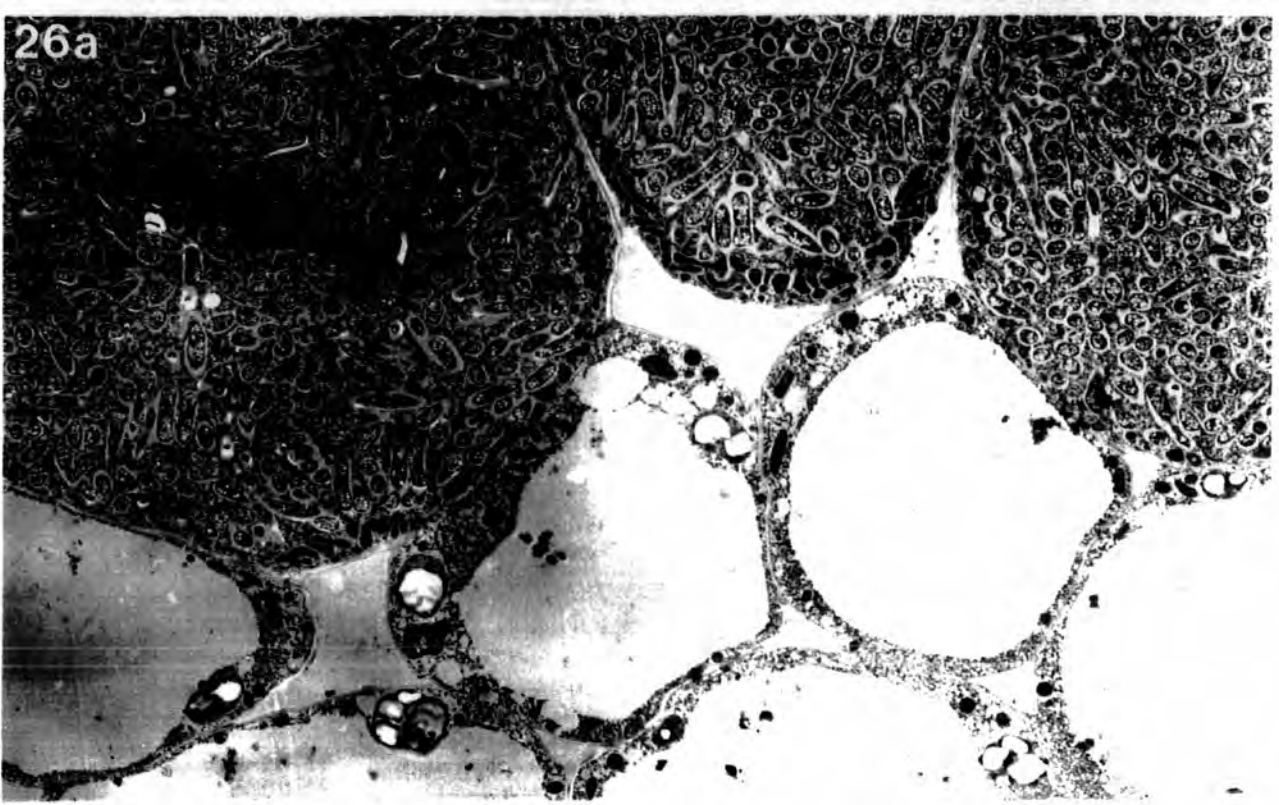
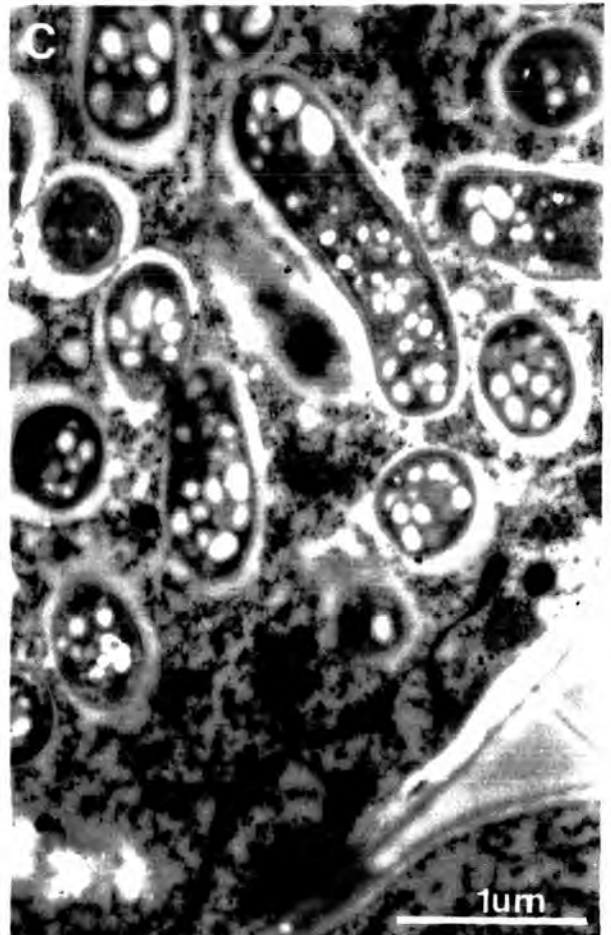
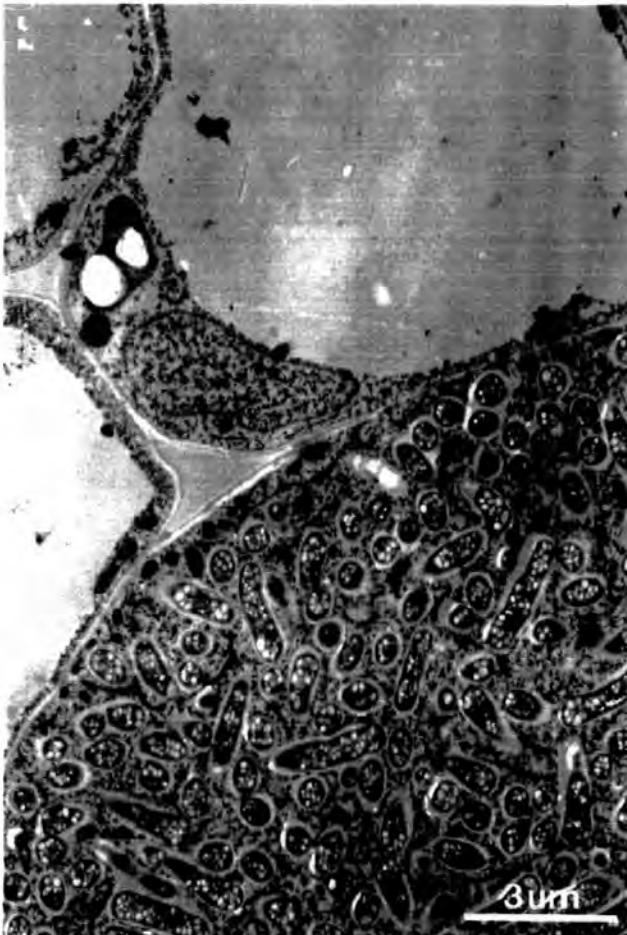

Plate 26 Thin sections labelled with glutamine synthetase IgG, and examined under the electron microscope, demonstrate the presence of glutamine synthetase in the host cytoplasm of the infected cells, and at a low level in the non infected cells.



effects on labelling cannot be ignored.

Taking into consideration these possible variables, results are summarized and then discussed in the context of previous reports on the expression of GS in *P. vulgaris* in 5.2.

Results suggest that *gln- α* is expressed in all tissues except the infected cells, with relatively high levels in the inner cortex and vascular endodermis.

gln- β shows expression throughout the nodule at the early and intermediate stages. Particularly high levels of *gln- β* were found in the infected, non-infected, inner cortical and vascular endodermal cells in early nodules. These levels decline in the infected, non-infected and vascular endodermal cells at the intermediate stage, and become very low or absent in the infected cells at the late stage. *gln- β* mRNA also declines in the inner cortical cells at the late stage, but remains the same, or increases in the vascular endodermis.

Table 7. Summary of the expression of the α , β and γ mRNAs and total GS protein in *P. vulgaris* nodule sections.

Developmental Stage	cell type	mRNA			Protein
		α	β	γ	
EARLY	I	-	++	++	++
	NI	+	++	++	++
	IC	++	++	++	++
	MC	+	+	-	+
	OC	+	+	-	++
	VE	++	++	-	++
MID	I	-	+	++	++
	NI	+	+	++	+
	IC	++	++	++	++
	MC	+	+	-	+
	OC	+	+	-	+
	VE	++	+	-	+
LATE	I	-	-	-	+
	NI	+	+	-	+
	IC	++	+	++	+
	MC	+	+	-	+
	OC	+	+	-	+
	VE	++	++	-	+

I - infected cells; NI - noninfected cells; IC - inner cortex; MC - mid cortex; OC - outer cortex; VE - vascular endodermis.

γ mRNA is present at high levels in the infected, non-infected and inner cortical cells, but is absent, or below detection limits, in the rest of the nodule in both the early and intermediate stages, and becomes confined to the inner cortex at the late stage.

GS protein levels, as demonstrated by the immunocytochemistry, are high throughout the nodule, with a slightly lower level in the mid-cortex at the early stage. GS protein declines in the non-infected, mid cortical and vascular endodermal cells at the intermediate stage. The high levels in the inner cortex and infected cells decline in the late stage (Plate 22). Infected cells at the late stage show early signs of senescence demonstrated by the decline in GS protein.

5.2. DISCUSSION

The model system of the expression of GS in developing root nodules can provide some very important insights into plant gene expression and regulation. There has been a range of studies carried out on the expression of GS in root nodules, at the isoenzyme, polypeptide and more recently the mRNA level.

From the early separation of two cytosolic isoenzymes of GS from nodules by ion exchange chromatography (Cullimore *et al.* 1984), Lara *et al.* (1984) went on to report the purification and polypeptide analysis of root and nodule GS isoenzymes. They reported that these were composed of distinctive polypeptides, and the nodule isoforms GS_{1,1} and GS_{1,2} were composed of different ratios of the γ and β polypeptides.

The confirmation of the existence of different γ and β conjugates (Cullimore and Bennett 1989) supported the suggestion by Robert and Wong (1986) that the different electrophoretic mobilities of nodule GS during development could be due to a continuous distribution of the polypeptides forming heterooligomeric enzymes.

Previous reports of the occurrence of the cytosolic GS mRNAs, polypeptides and isoenzymes *P. vulgaris* nodules and their patterns of accumulation during nodule development are now discussed in relation to the results presented in this thesis.

5.2.1. The Location of GS in *P. vulgaris* Root Nodules

Cullimore and Mifflin (1983) raised GS antisera to GS_{1,1} and GS_{1,2}, and reported that each recognised both forms of nodule GS. The specific

activity of GS_{m2} antisera was higher than that of GS_{m1}, and they therefore only worked with the former. They reported that no polypeptides could be detected when antiserum was incubated with extracts of free-living *Rhizobium*. They also reported that antisera did not cross react with GS from free living or bacteroid *Rhizobium phaseoli*, but the antiserum was able to recognise all the cytosolic and leaf forms of GS from *P. vulgaris*. Some of this antiserum was donated for use in my work. This antiserum has been used to localize total GS protein, excluding that from the *Rhizobium*, in the *P. vulgaris* root nodule tissue studied.

Cullimore and Miflin (1983) demonstrated that absorption of antisera with root GS removed most of the antibodies which would cross react with both forms, resulting in the preparation of antiserum which would specifically recognise GS_{m1}. This led the way for a more extensive investigation into the localization and identification of GS isoenzymes and polypeptides.

Lara *et al.* (1984) reported that the α and β polypeptides were readily detectable in roots, but there were no detectable γ polypeptides. Cullimore *et al.* (1984) were the first to report the presence of the γ polypeptide which was initially considered to be a nodulin, in that it was nodule-specific, as neither the polypeptide nor the *gln- γ* mRNA were detected in roots or leaves (Lara *et al.* 1984; Gebhardt *et al.* 1986). However Bennett *et al.* (1989) have reported that *gln- γ* mRNA and polypeptides are detectable at very low levels in roots, which suggests *gln- γ* is therefore 'nodule-enhanced' rather than 'nodule-specific' and not strictly a nodulin.

Lara *et al.* (1988) suggested that the γ polypeptide could be

located in the peribacteroid space, surrounding the bacteroids and not the host cell cytosol. This has, however, been suggested as unlikely as the γ cDNA (Bennett *et al.*, 1989), and the genomic (Forde *et al.*, 1989) clones have shown that the γ polypeptide is not synthesized with additional transmembrane targeting sequences, and the γ polypeptides assemble with the β polypeptides which are almost certainly in the cytosol (Cullimore and Bennett, 1988). Awonaike *et al.* (1981) used sucrose gradients to separate out nodule contents, including the successful separation of plant mitochondria from bacteroids. They conclusively demonstrated the presence of GS in the plant cytosol. This does not however exclude the possibility of the contents of the peribacteroid space being included with the plant cytosol as a result of peribacteroid membrane rupture. The immunocytochemical results which I have obtained at the electron microscope level have shown no evidence of the presence of any GS in the peribacteroid space.

In summary, the organ-specific expression of the α , β and γ polypeptides has been considered at the isoenzyme, polypeptide and mRNA levels. Initially the isoenzyme GS_{n1}, which contains a high proportion of the γ polypeptide was considered to be nodule specific, whilst the β (making up GS_{n2}) and α polypeptides were considered to be more widespread and found in root and leaf tissue, as well as high levels in embryo radicles and young roots (Ortega *et al.* 1986). More recent reports have however suggested that the α polypeptide is present in nodules (Padilla *et al.*, 1987), and that γ is present in other plant tissues (Bennett *et al.*, 1989), although at a very low level. Thus α is not nodule-exclusive, nor γ nodule-specific.

Cullimore and Bennett (1988) suggested that the tissue and

cellular (rather than organ) specificity of this GS expression needs to be determined. Similarly Padilla *et al.* (1987) suggested that conclusive evidence of a particular intercellular localization of the GS polypeptides in *P. vulgaris* nodules had not been demonstrated, and that the mechanism for regulation may include the possibility of a differential contribution from distinct cell types found in nodule tissues (e.g. infected and non-infected cells), to the accumulation of GS polypeptides or to the corresponding synthesis of mRNAs.

Few reports of the cellular location of the polypeptides have been made. The *in situ* hybridization results presented here agree with the observation by Chen and Cullimore (1989) who dissected nodule tissue and demonstrated γ and β polypeptides in the central region, but only β in the outer cortex. In my investigations *gln- β* mRNA was consistently detected in both the central and cortical tissue, whilst the *gln- γ* mRNA was predominant in the central region. The location of the *gln- α* mRNA in both the cortical and central region also corresponds with that reported by Padilla *et al.* (1987).

The specific cellular locations, and implications they have for the control of the GS expression are discussed in Chapter 7. Before this however the other factors, such as the time course and quantification of both the expression and appearance of these polypeptides are discussed.

5.2.2. The Temporal Pattern of Expression of GS mRNA and Protein in *P. vulgaris* Root Nodules

Padilla *et al.* (1987) demonstrated that the α polypeptide was present at a relatively low concentration throughout nodulation, the β

polypeptide showed an increase, from a relatively high level, up to 32 days after inoculation, whilst the γ polypeptide was detectable at a low level at day 10, and showed a peak 12-13 days after inoculation, and was as abundant or more abundant than the β polypeptides from days 14-32. They found that γ was the most abundant GS polypeptide for a transient period. The results presented in this thesis for the time course of the accumulation of GS mRNA demonstrated by *in situ* hybridization follow a similar pattern.

From *in vitro* studies, Padilla *et al.* (1987) were able to demonstrate the presence of α translatable products up to day 13, and the increase in γ translatable products from day 13 onwards. The close correlation between the translatable products and protein levels suggested that the possibility of post-transcriptional regulation could be excluded. This agrees with the suggestions by Cullimore and Bennett (1988) and Forde and Cullimore (1989).

The α polypeptide has been shown to be the major GS polypeptide in embryo radicles up to 5 days after germination, when β then predominates (Ortega *et al.*, 1986). Padilla *et al.* (1987) suggested that this may be analogous to the situation in nodules where early synthesis of the α polypeptide declines as the nodule matures.

Lara *et al.* (1984) demonstrated that $GS_{n,1}$ increased significantly during nodulation, whilst $GS_{n,2}$ remained constant throughout nodulation. Up to day 10 they reported only $GS_{n,2}$ was detectable. $GS_{n,1}$ was then detectable at day 12 and increased to a higher level than $GS_{n,2}$ by day 18, at which point $GS_{n,1}$ accounted for 84% of the total GS in root nodules, whilst $GS_{n,2}$ remained constant or decreased slightly, and showed no difference in levels from non-nodulated roots. Gebhardt *et*

et al. (1986) however measured the abundancies of mRNA levels by an S1 nuclease protection technique. They suggested that *gln-γ* mRNA was first detectable at approximately day 16, and rose up to day 19 (because of differences in rates of development this corresponds with the early stage used in this work). Bennett *et al.* (1989) measured the abundance of the GS mRNAs qualitatively using a sequence specific RNase protection technique, and reported similar results (illustrated in Fig.5) to those reported by Padilla *et al.* (1987) from *in vitro* translation studies. These results show that the *gln-γ* mRNA levels increase sharply from day 5, to peak at day 12-13, then show a sharp decline. The *gln-β* mRNA levels start at a relatively high level, peak around day 13, and then decline, whilst the *gln-α* mRNA shows a slight decline around day 13, and remains at a very low level.

Forde and Cullimore (1989) suggested that the relative constancy in abundance of *gln-β* mRNA during nodulation in *P. vulgaris* may belie more complex changes at the cellular level. The results presented here, on the cellular levels of GS mRNA, suggest there are differences and changes at the cellular level.

Figure 6 shows the levels of α , β and γ mRNAs detected in the different nodule cell types, at the early, intermediate and late stages of nodule development. These results show how the expression of the GS mRNAs does vary considerably both with time and with the different cell types. Although it is difficult to compare the mRNA levels quantitatively, there appears to be a good correlation between the total GS protein levels detected by immunocytochemistry and the levels of mRNA.

GS mRNA abundance (pg/ug total RNA)

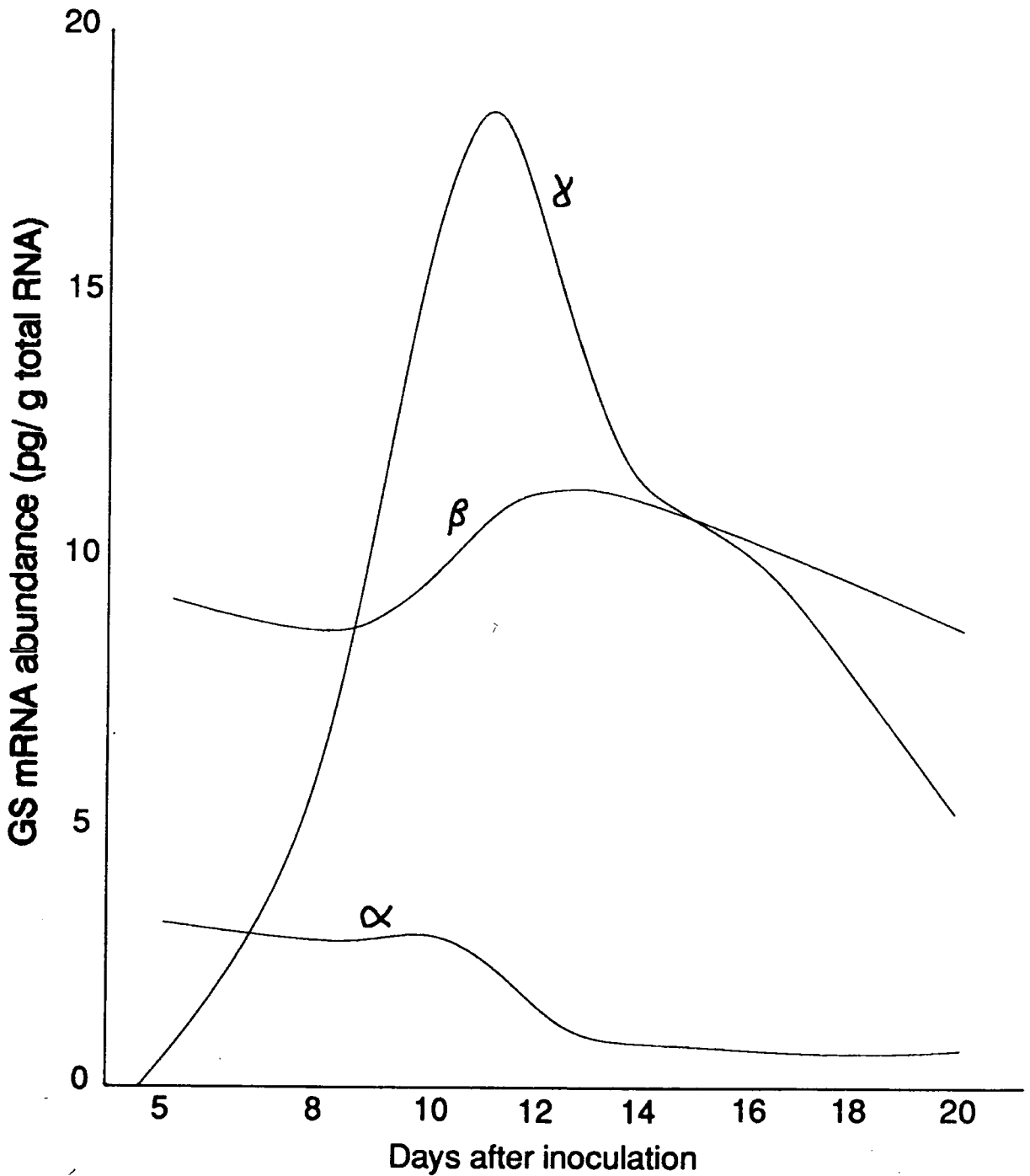
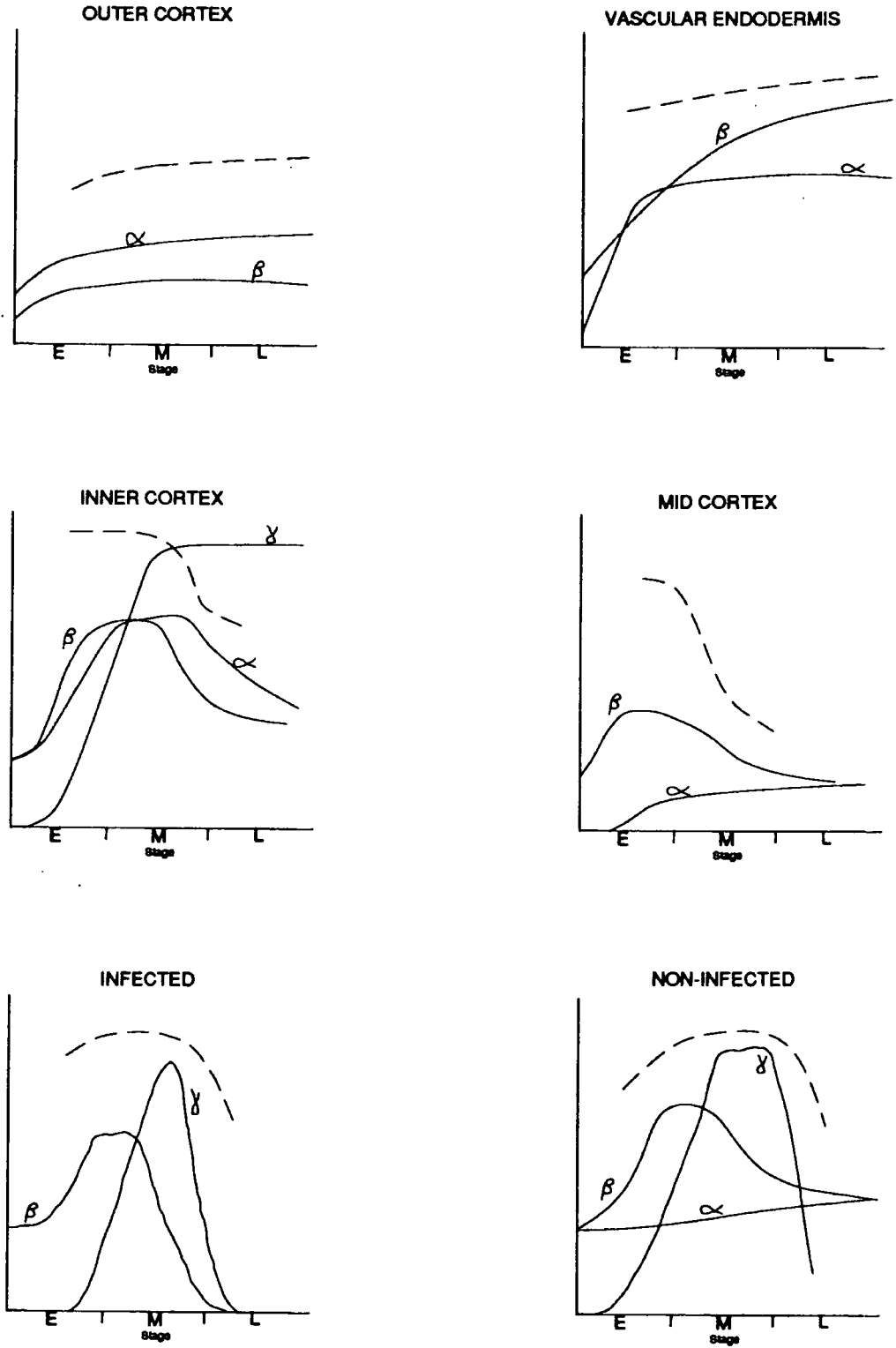

Fig. 5 Graph to show glutamine synthetase polypeptide mRNA levels in *Phaseolus* detected in homogenized nodule tissue using an RNase protection technique, (from Bennett *et al.* 1989).

Fig 6. α , β and γ mRNA levels detected by *in situ* hybridization in the different nodule cell types over a 30 day lifespan—solid lines, and total glutamine synthetase levels shown by immunolabelling—broken lines.



5.2.3. The Assembly of the GS Polypeptides in *P. vulgaris*

It is now relatively well established (Robert and Wong, 1986; Cullimore and Bennett, 1988; Forde and Cullimore, 1989; Bennett *et al.*, 1989) that the γ and β polypeptides form heterooctameric isoenzymes, made up of differing proportions of the γ and β polypeptides. Padilla *et al.* (1986) reported that the ratios of transferase to synthetase activities of total GS which alter during nodulation (Lara *et al.*, 1984), did not correspond directly with the induction of GS₁₁₇. This lack of correlation between activity ratios and reported appearance of the GS isoenzymes is also very likely due to the differential assembly of the polypeptides. However it has been reported that the proportions of the β_{85} to β/γ isoenzymes is greater than would be expected if the formation of the heterologous isoenzymes was totally random (Padilla *et al.*, 1986; Cullimore and Bennett, 1988). The β polypeptide may therefore have a higher affinity to combine with itself, than with the γ polypeptides. The variation in the cellular location and the relative levels of polypeptide mRNA and polypeptides may play an important role in the regulation of heteromer formation, i.e. where the β polypeptide predominates it assembles with itself, but where γ dominates in the same cell type the formation of heteromers is encouraged.

Cullimore and Bennett (1988) reported that the assembly of the α subunit had not been investigated. From these results the possibility arises that isoenzymes comprising of α and β , or even α , β and γ subunits exist in some nodule cell types.

The relative levels of α mRNA have been found to be higher than expected in this work. Previous reports have suggested the *gln*- β mRNA is approximately 5-10 fold more abundant than *gln*- α , (Forde and

Cullimore, 1989; Cullimore and Bennett, 1988). It seems unlikely that the α probe used for these *in situ* hybridizations was either much more efficient, or the α mRNA in the sections was significantly more accessible. There is therefore a possible discrepancy between the relatively low α mRNA levels reported in homogenized tissue and the relatively high levels detected *in situ*. This could be due to the differential contribution of cytoplasm from each cell type in homogenized tissue preparations, which would affect all three cytosolic GS mRNAs to different extents, depending on the particular cellular locations.

5.2.4. Implications for the Spatial and Temporal Expression of GS in *P. vulgaris* Root Nodules

Evidence suggests that the abundance of the GS mRNAs is directly reflected in the protein levels, and therefore any translational control, if present at all, does not significantly affect the polypeptide levels (Mifflin *et al.*, 1985; Gebhardt *et al.*, 1986; Padilla *et al.*, 1987; Cullimore and Bennett, 1988). The *in situ* hybridization studies presented here have shown that there is a complex spatial and temporal variation in distribution of the three cytosolic GS mRNAs. The composition of the GS isoenzymes within the nodule is therefore likely to be determined by this distribution.

Robert and Wong (1986) suggested that the assembly of the γ and β polypeptides may be regulated by temporal and/or spatial separation of the two subunits, which is in agreement with the results presented in this thesis. Padilla *et al.* (1987) reported the presence of α , β and γ polypeptides in nodules between days 10-13 after inoculation, however

as the γ levels rose the levels of α transcription were reported to fall, whilst the β remained constant. This represents the differential synthesis of the three transcripts in the emerging nodule tissue. They reported that at the onset of nitrogenase activity only β and γ transcripts were detectable, and the $\beta:\gamma$ ratios remained similar in nodules of the same age. Gebhardt *et al.* (1986) demonstrated that the GS₁ isoenzyme (thought to consist of predominantly α subunits) could be specifically repressed during nodulation. The reported decline in the *gln- α* mRNA was not very evident from *in situ* hybridization results reported here. However, if the α polypeptide is included in the γ/β isoenzymes GS_{1,2} and/or GS_{2,2}, an α_{60} isoenzyme (GS₁), would be neither present nor detectable in nodules i.e. the α subunit may be present in nodules as a minor component of GS_{1,2} and/or GS_{2,2}.

The *in situ* hybridization results have shown a marked cellular and temporal variation in the GS subunit mRNA levels. It seems very likely that a form of temporal and spatial regulation at the organ and also, the cellular level exists, and controls the subunit composition of the GS isoenzymes.

Lara *et al.* (1984) suggested that the GS polypeptides, particularly γ , increased to high levels during nodulation to assimilate the ammonia produced by the bacteroids. This does not however account for the different isoenzymes or how they are induced.

The active site of the *Salmonella typhimurium* enzyme, and probably that of the higher plant enzymes, is formed by a combination of two active half-sites donated by adjacent subunits (Forde and Cullimore, 1989). It is possible that in *P. vulgaris* Gs octamers have different kinetic properties, and function at their optimum under different

conditions; different cell types, particularly in an organ such as a root nodule where they have different metabolic functions would contain different micro-environments, i.e. the infected cells in the central region, have very different metabolic demands, and as a result, a very different micro-environment, from the vascular endodermal, or cortical cells, which are less closely involved with the bacteroids, and the ammonia produced by them. The cells of the central infected region are associated with higher levels of leghaemoglobin and therefore lower oxygen levels (Vanden Bosch and Newcomb, 1988). It has been suggested that the mid-cortical cells form a diffusion barrier between the central nodule tissue and the outer cells, (Frazer, 1942). It would be unusual to find an enzyme which is able to function at an optimum in both the central infected tissues and the outer cortical tissues, of a root nodule. This is one possible factor which may account for the differential expression of GS in *P. vulgaris* root nodules. This does not however explain how this differential expression is controlled.

One of the signals for the induction of gene expression in a developing root nodule may be the onset of dinitrogen fixation. Padilla *et al.* (1987) have demonstrated that the γ polypeptide first appears at least three days before nitrogenase activity. It has also been shown that the level of *gln- γ* mRNA is affected by nitrogen fixation (Forde and Cullimore, 1989). Experiments with rhizobial mutants, which are unable to fix nitrogen but produce the normal nodule cytology, have shown that the *gln- γ* gene is still expressed although at a lower level in these *fix⁻* nodules (Lara *et al.*, 1983). However no increase in nodule GS above that detected in uninoculated roots, could be detected in roots infected with rhizobial mutant strains which produce nodular

swellings but lacking intracellular rhizobia, (Vanden-Bosch *et al.*, 1986; Noel *et al.*, 1986).

The induction of *gln-γ* (and possibly *gln-β* and *gln-α*) mRNA therefore seems to require a certain stage of nodulation to be reached which may include the invasion by the infection thread, or release of the rhizobia. However the expression of the *gln-γ* gene cannot be obligately dependent on the symbiont, as it is detectable at low levels in other tissues.

It therefore seems that expression of the cytosolic GS genes associated with nodulation is at least partially affected by two or more factors; the invasion of rhizobia, which could trigger the significant rise in gene expression associated with nodulation, and the onset of nitrogen fixation and the production of ammonia, which possibly serves to enhance or prolong expression. It is possible that these same regulatory mechanisms may also operate in a negative manner on the *gln-α* gene, but there is no evidence for this.

6. THE EXPRESSION OF GS/GUS GENE FUSIONS IN NODULES OF TRANSGENIC

Lotus corniculatus PLANTS

6.1. *In situ* HISTOCHEMICAL RESULTS

As a further investigation into the expression of the GS isoenzymes, the techniques optimized on *P. vulgaris* have been applied to transgenic *Lotus corniculatus* plants containing the 5' flanking regions from the *P. vulgaris* *gln-β* and *gln-γ* genes which had been fused to the GUS reporter gene (Forde *et al.*, 1989).

The *in situ* hybridization, and immunocytochemical techniques, required only a small amount of adaptation from those used for the *P. vulgaris* nodules. The same β probe, from the 5' flanking region of the *P. vulgaris gln-β* cDNA, was used for the β/GUS constructs. Similar results were obtained using a GUS cDNA probe. The γ RNA probe used for the *P. vulgaris* studies was from the 3' flanking region of the *gln-γ* gene and was therefore not suitable for hybridization with the γ constructs; a GUS cDNA probe (provided by Miss M. Gibbs, University of Durham) was used for analysis of the *gln γ*/GUS lines, instead. Root sections proved difficult to keep on slides during hybridizations.

Thick sections were stained for GUS using 5-bromo-4-chloro-3-indolyl glucuronide (X-gluc), as described in 2.4.3. Forde *et al.* (1989) have published some excellent results of thick sections of the same transgenic plant lines stained with X-gluc (and this technique was therefore not pursued in my work). The staining of thin sections, or the post-embedding and sectioning of tissues after staining, was found

to be unreliable and difficult to reproduce. Early results however, did indicate, that post fixation and embedding of X-gluc-treated tissue effectively maintained the staining intensity. The subsequent visualization of the blue precipitate in thin sections was however often difficult and insufficient to show up in photomicrographs. Whole root incubations with X-gluc showed variation with size, age and location on the plant, and proved susceptible to damage which induced further staining.

Immunocytochemical labelling of sections with a GUS antibody, from Dr M Watson, University of Durham was found to be a more reliable and reproducible method, which permitted a higher resolution than X-gluc. It was therefore used to localize the GUS enzyme in sections of transgenic *L. corniculatus*. The nodules used in these experiments were generally in the intermediate to late stages of development, and correspond to the intermediate and large-pink stages (respectively) described by Forde *et al.* (1989).

6.1.1. The Expression of the β /GUS Construct

Sections of an intermediate stage *L. corniculatus* nodule on plants containing the β /GUS construct were hybridized with the β RNA probe used for *P. vulgaris* and the biotinylated probe was detected with alkaline phosphatase. β /GUS mRNA was demonstrated in the non-infected cells of the central region, the inner cortex, and particularly the vascular endodermal cells (Plate 27a). For comparison a control *L. corniculatus* nodule, which does not contain the GUS gene, but also hybridized with the same β probe, is illustrated in Plate 27b. Sections containing the γ /GUS construct and hybridized with this β probe showed

27a

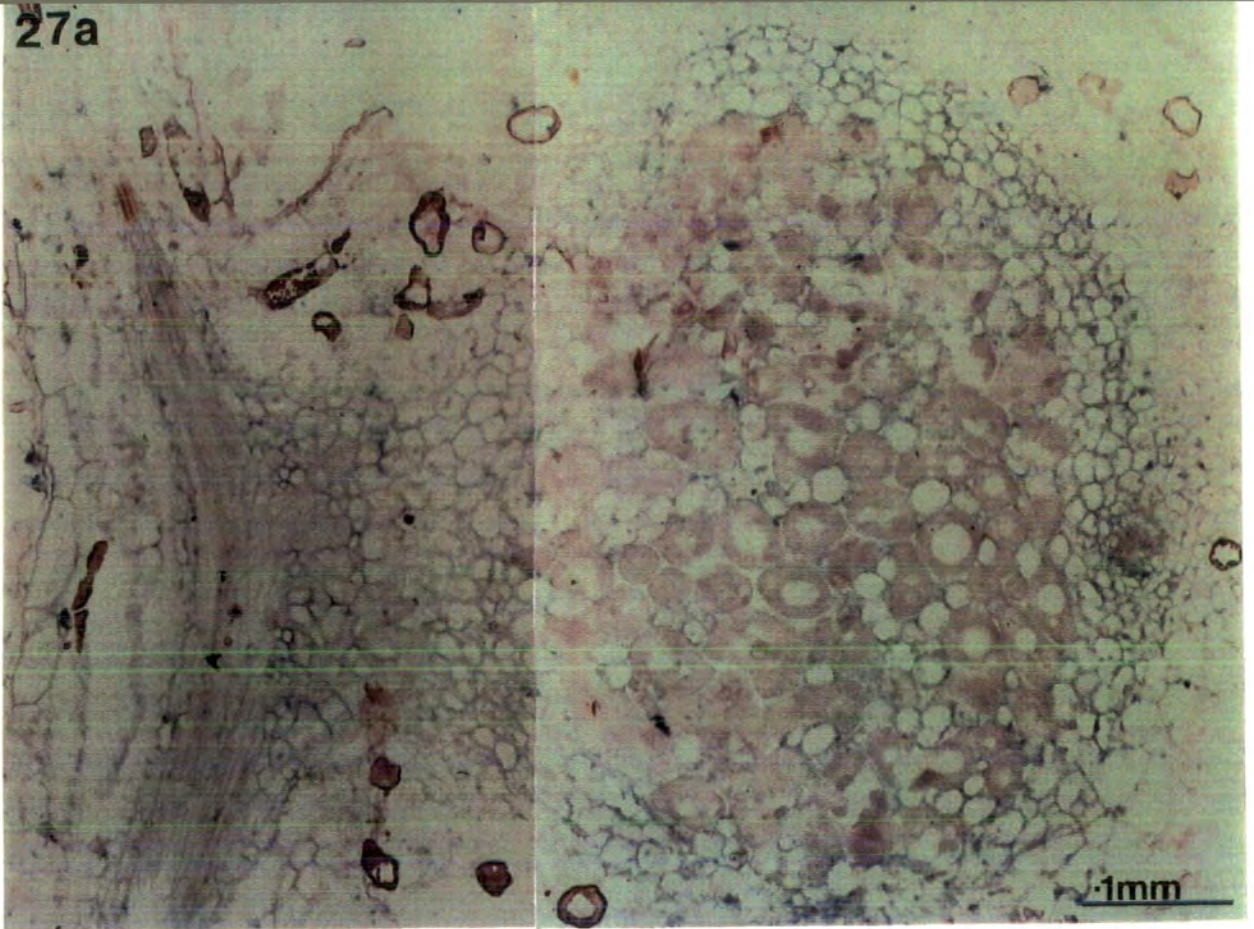
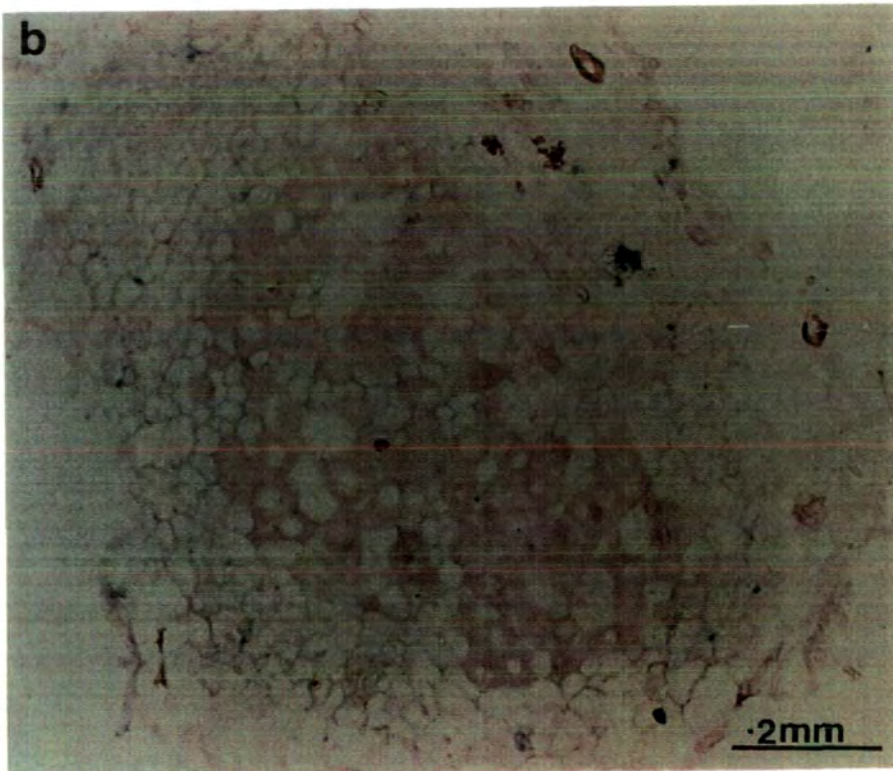

Plate 27. Plate 27a shows the *Phaseolus* β probe hybridized to a section from transgenic *Lotus corniculatis* nodule, expressing the β -glucuronidase reporter gene, from the *Phaseolus glp* β /GUS construct. Plate 27b shows a control section from a *Lotus* plant without the GUS gene, hybridized with the same probe.



containing the γ /GUS construct and hybridized with this β probe showed no detectable labelling.

A particularly high level of β /GUS mRNA is demonstrated in the vascular endodermal cells of a slightly older nodule (Plate 28a) from the same line as that shown in Plate 27a. This also shows there is a greater intensity of labelling around the root connection, with a lower level in the non-infected cells in the central region. A similar pattern of GUS distribution was found in thick sections stained with X-gluc (Plate 28b). Immunocytochemical labelling with gold colloid visualization on sections from the same line demonstrated a similar distribution for the GUS protein, as for the mRNA.

6.1.2. Expression of the γ /GUS construct

Very early emerging nodules from transgenic *L. corniculatus* plants containing the *gln- γ* transcriptional fusion (line J₁D₁), were sectioned and hybridized with a GUS cDNA probe. These showed, even at the very early stage, that the γ /GUS mRNA was present in the developing tissue (Plate 29a). The root attachment, inner cortical and infected cells of the older nodule illustrated in the lower half of Plate 29a also shows the presence of γ /GUS mRNA. An early to intermediate stage nodule (line J₁D₁), showed γ /GUS mRNA in the infected and non-infected cells of the central region, and particularly in the inner cortex, including the vascular endodermis (Plate 29b). There was no detectable expression in the surrounding mid and outer-cortical, or root tissue. A slightly older nodule from the same line again showed the presence of γ /GUS mRNA in the infected, non-infected and inner cortical regions (Plate 30a).

A similar pattern of GUS protein distribution to that demonstrated

28a

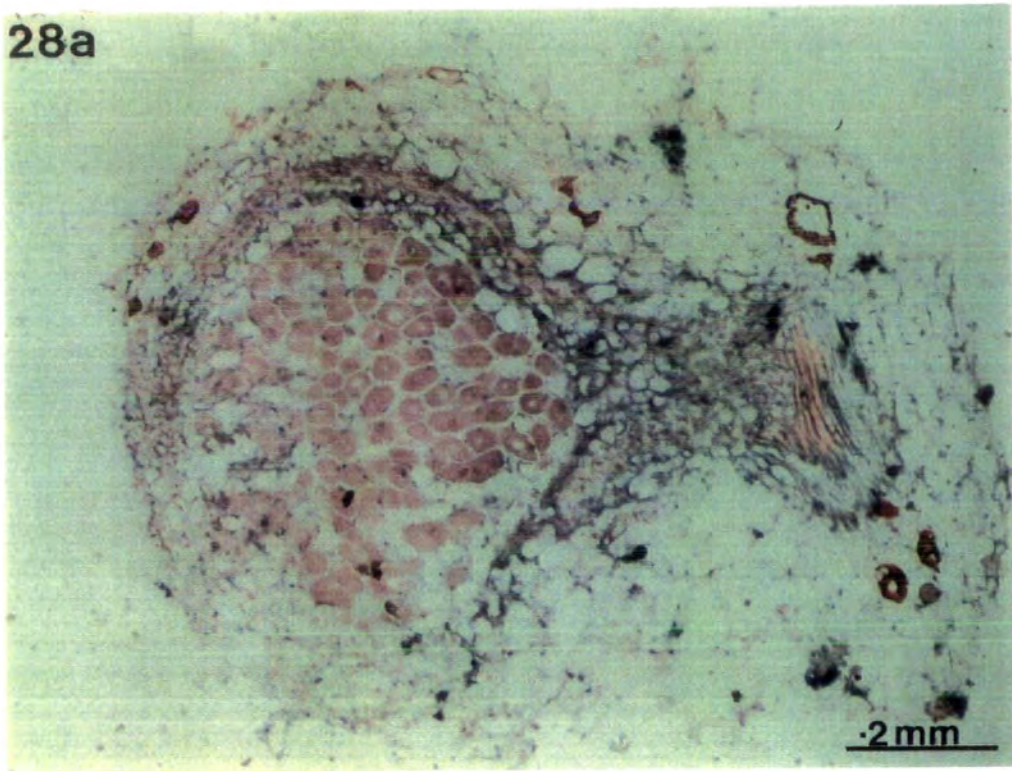
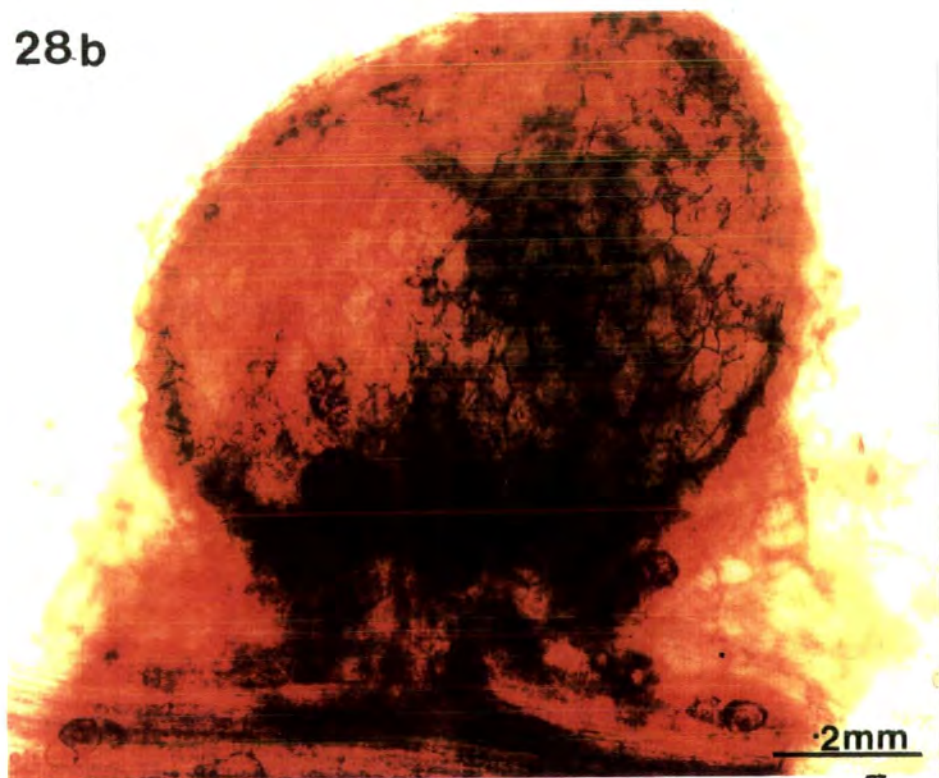

Plate 28. 28a shows a mid-late stage section from a transgenic *Lotus* plant containing the β -GUS construct, hybridized with the *Phaseolus* RNA β probe; the expression of the GUS construct is particularly high in the vascular endodermal tissue at this stage. Plate 28b shows a thick section from a plant containing the same construct, labelled with X-gluc, which again shows high levels of GUS activity around the vascular tissue. A similar pattern of labelling was also demonstrated by immunolabelling, (not shown).

28b



29a

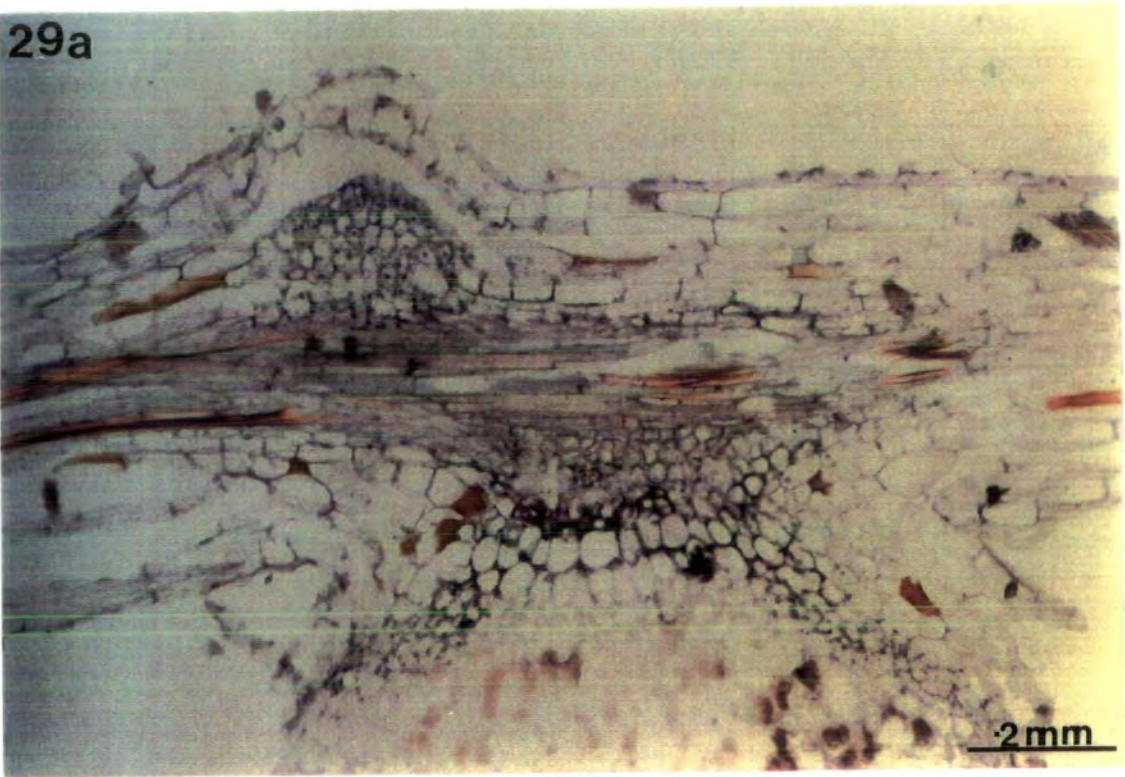
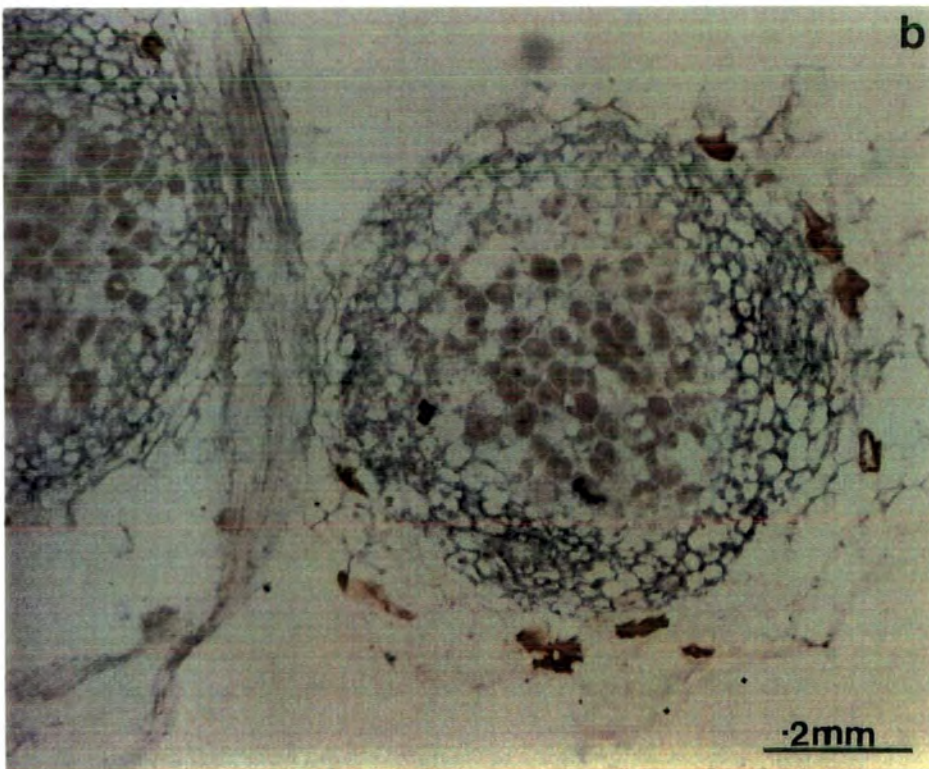

Plate 29. Sections from a *Lotus* plant containing the γ /GUS HH68 construct, line J₁D₁, hybridized with a biotinylated GUS cDNA probe, and labelled with alkaline phosphatase, shows a high level of transcriptional activity in a very early nodule, and the root attachment of a mature nodule (a). A particularly high level of expression was detected in the inner cortical tissue in nodules from this line (b).



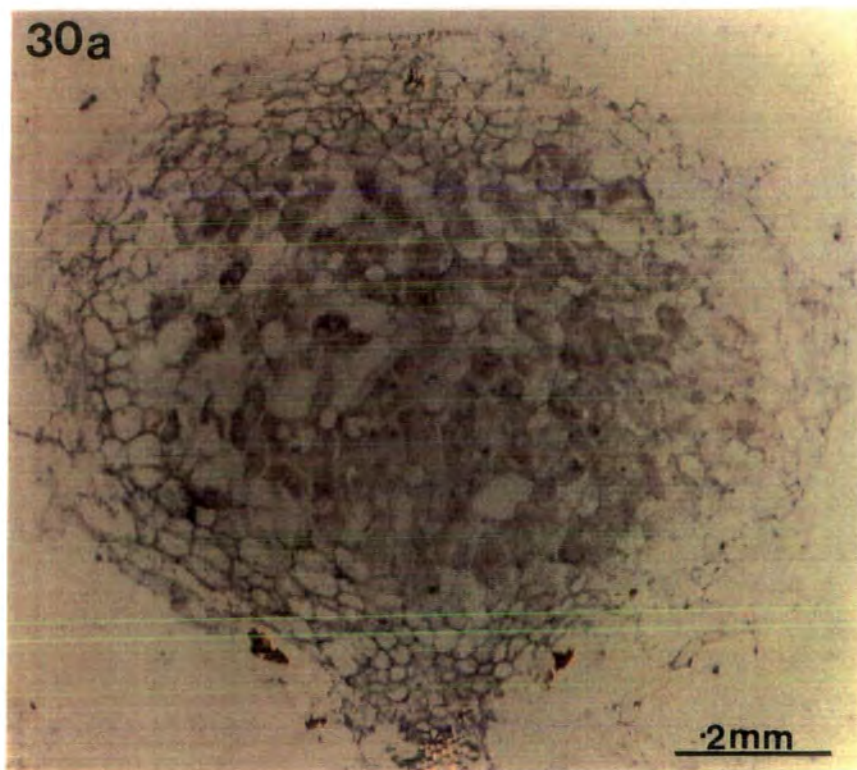

Plate 30 A section from a late stage nodule of a transgenic *Lotus* plant containing the γ /GUS construct, line J₁D₁, hybridized with the GUS probe, shows particularly high levels of GUS expression, in the inner cortex and non infected cells of the infected region (a).

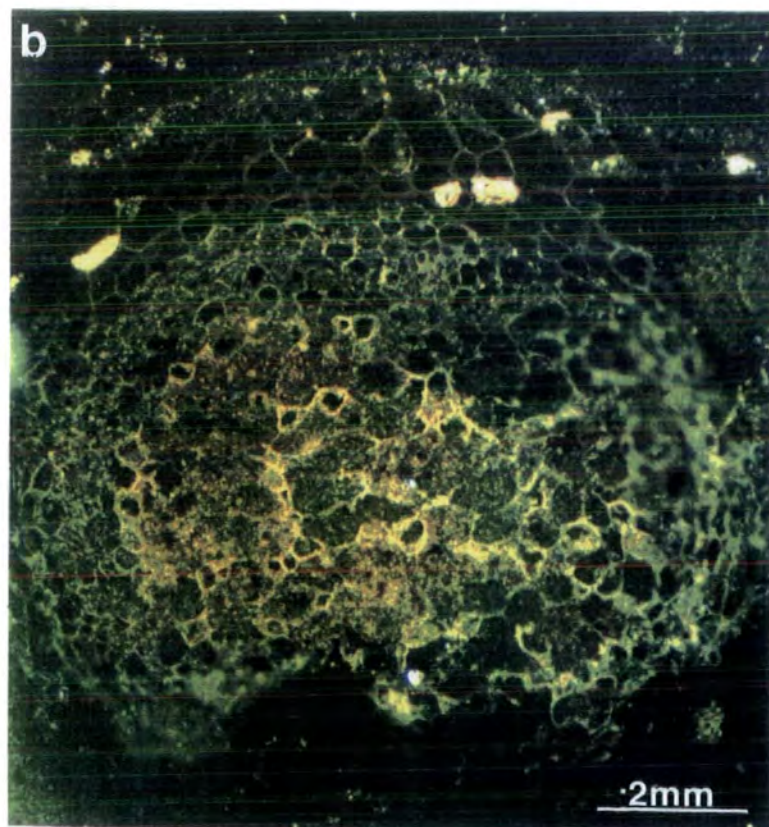

Plate 30b, shows a section immunolabelled for GUS, using a colloidal gold secondary antibody, and silver enhanced. The labelling shows a pattern of labelling similar to that shown in 30a, with particularly high levels of GUS in the non infected cells of the central region.

labelling (Plate 30b). The GUS protein was localized to the non-infected cells, and to a lesser extent the infected and inner-cortical cells of the nodule. The very intense silver staining in three cells of the mid-cortical region, demonstrated in Plate 30b, represents non-specific labelling of the polyphenolic, flavolans characteristic of *L. corniculatus* (Boland *et al.*, 1978; Pankhurst *et al.*, 1979; Vance *et al.*, 1982). The levels of these flavolans differed considerably between the various plant lines.

Slightly older nodule sections from the same plant line, labelled with the GUS antibody and subsequently visualized with the alkaline phosphatase technique, are shown in Plate 31. The sections were not counterstained in order to show up any low level of staining in the infected cells. In these late stage nodule sections the GUS activity was predominantly confined to the non-infected, and inner cortical cells. There was no detectable enzyme in the infected cells.

A different pattern of expression was seen in line B₁B₁, which carries the *gln-γ* transcriptional fusion (Plate 32). In this case γ /GUS mRNA was detected predominantly in the infected cells of the nodule (Plate 32a). The immuno-localizations of GUS by gold and silver (Plate 32b), and alkaline phosphatase (Plate 32c), also suggest that the expression was predominantly in the infected cells of the nodule, although Plate 32b suggests GUS may also be present in the non-infected cells. The level of flavolans in this line is also high. The B₁B₁ plant line contained the transcriptional as opposed to the translational γ /GUS fusion in lines J₁D₁, and C₁E₁.

The localization of GUS in the third γ /GUS line C₁E₁, containing the same translational fusion as the J₁D₁ line, was also examined by

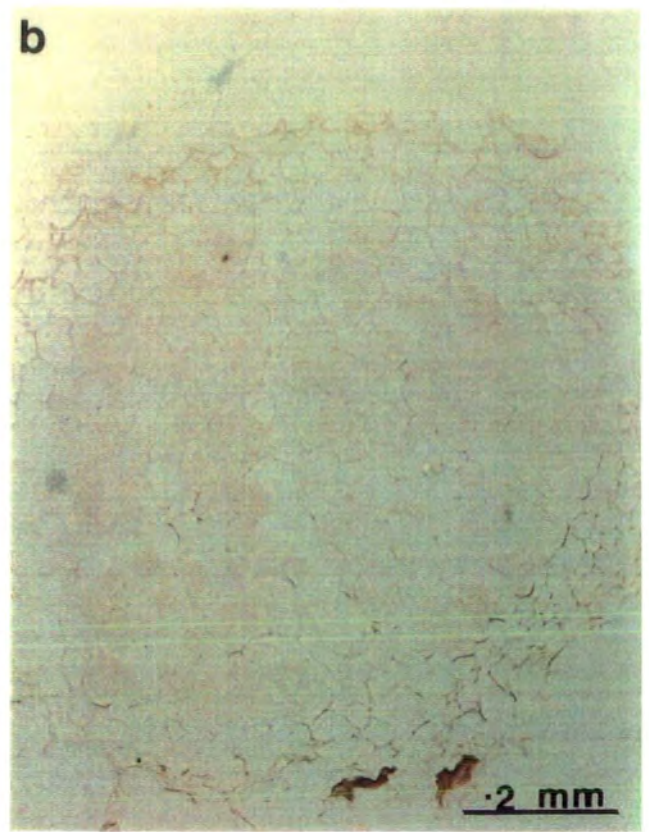
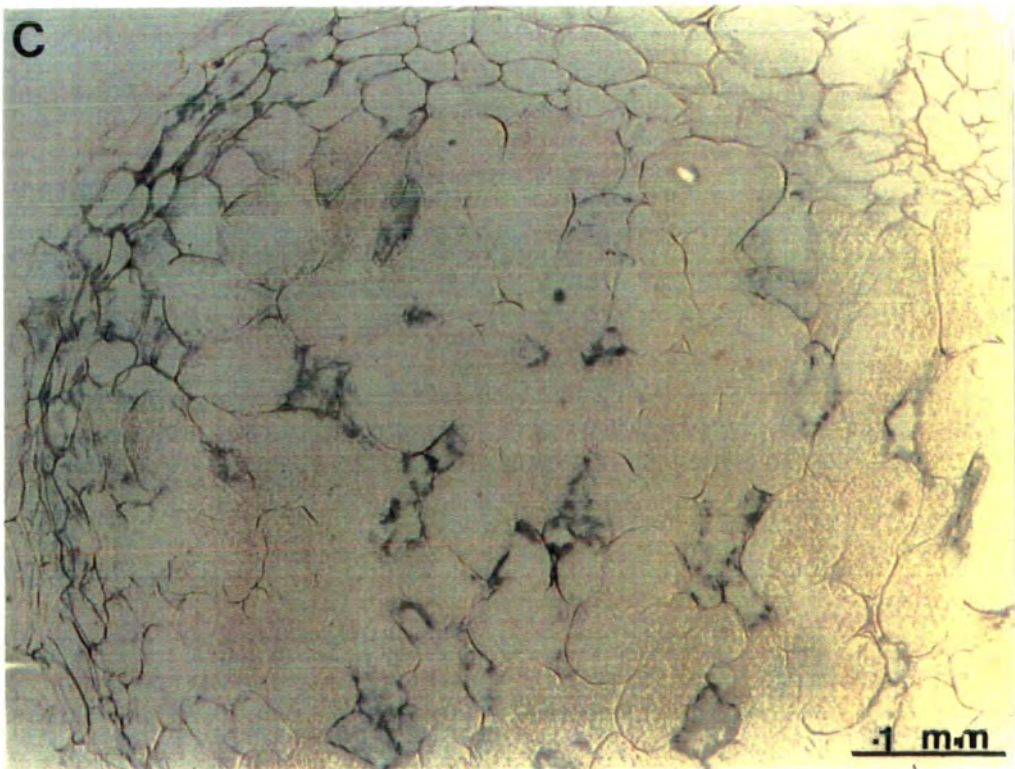

Plate 31. Mid-late stage nodule sections from transgenic *Lotus* plants, line J₁D₁, incubated with the GUS anti-body, and labelled with alkaline phosphatase, as in Plate 30, show heavy labelling in the non infected cells (a), in contrast to the control section labelled with rabbit pre-immune serum (b). Plate 31c shows a higher magnification of 'a'.



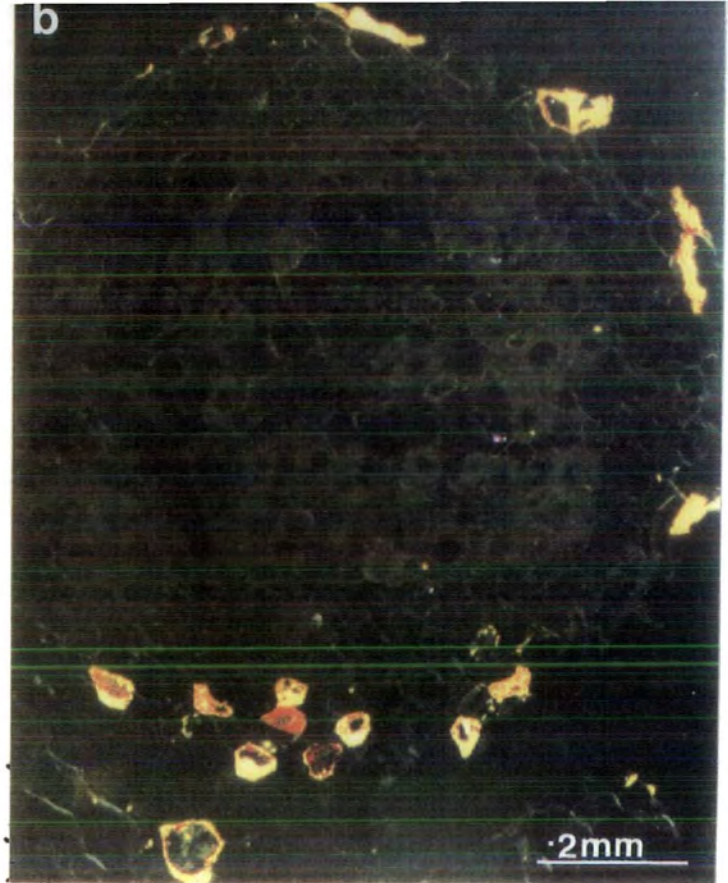

Plate 32. BA68 γ /GUS constructs, line B₁B₂, in *Lotus*. 32a shows a section hybridized with the GUS cDNA probe, in this line, expression is largely confined to the infected cells only.

Immunolabelled sections for GUS, with gold and silver (b), and alkaline phosphatase (c), show a similar pattern of GUS distribution, although only detectable at a low level.



histochemical X-gluc staining. Although the sections are very thick and therefore the cellular resolution bad, the level of GUS is particularly high in the infected and inner-cortical cells in both the very early nodule (Plate 33a), and the intermediate stage nodule (Plate 33b). Although the different cell types cannot be clearly distinguished, the infected cells appear to show the most intense staining, similar to that demonstrated in line B₁B₁ (Plate 32): Although the inner cortical tissue also shows staining for GUS, the resolution is not sufficiently clear to rule out the possibility of a high level of staining in the non-infected cells within the central area, as shown by the γ /GUS translational fusion line J₁D₁, (Plates 29 - 31). The preferential staining of damaged tissue cannot be eliminated with these unfixed tissue sections. The pH and oxygen/peroxide levels within the tissue, which undoubtedly vary between cell types in a root nodule can also affect the level of X-gluc staining considerably. The use of other techniques such as *in situ* hybridization, and immunocytochemical labelling were not as reproducible in this line C₁E₁, as in the other lines.

Similar variations in expression to those seen between the J₁D₁ and C₁E₁ lines which contain the same construct, may also be responsible for the differences in expression between the two translational fusions (plant lines J₁D₁ and C₁E₁) and the transcriptional fusion (B₁B₁) although the different patterns of expression may also be a consequence of the different gene constructs. Studies of a number of plant lines for each construct may help to clarify this problem.

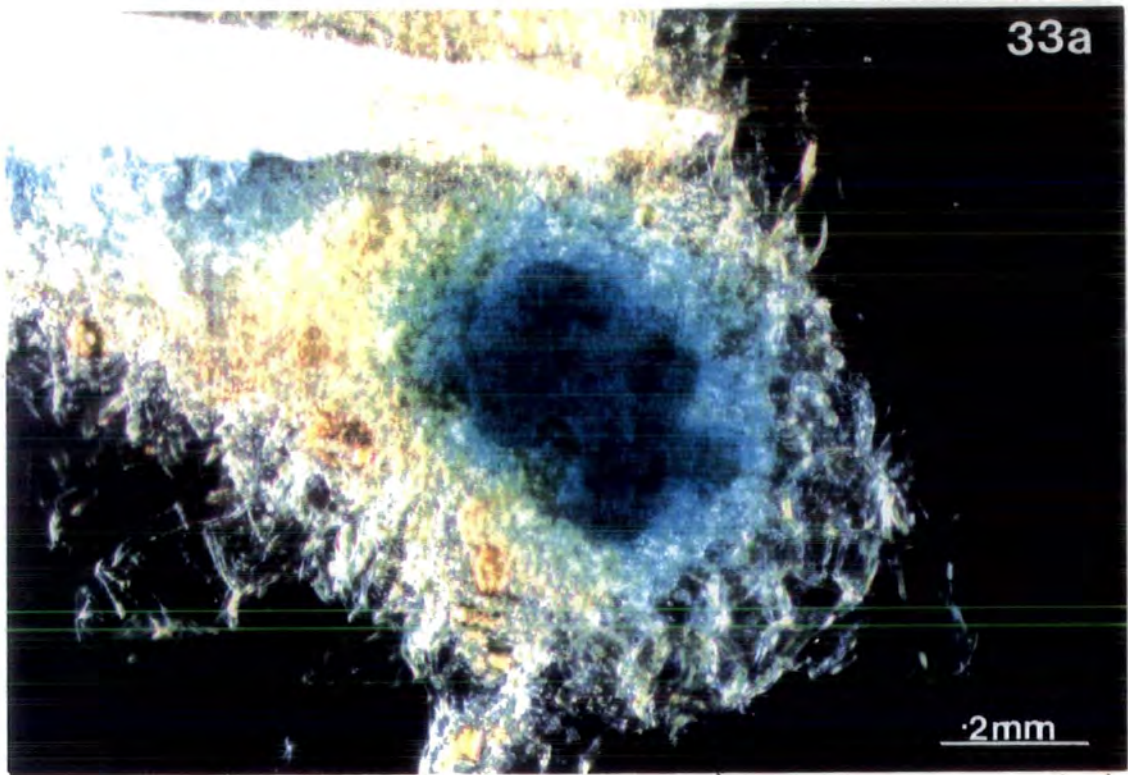
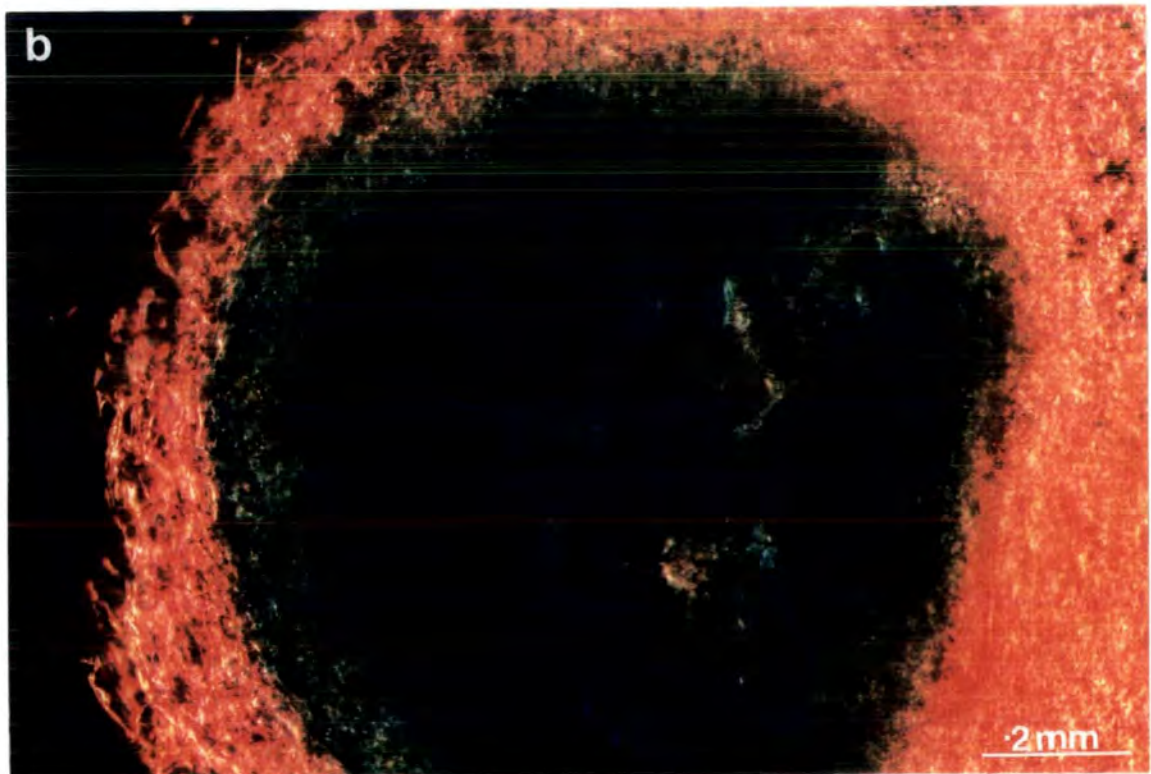

Plate 33 An early nodule from a *Lotus* plant containing the HH68 γ /GUS construct, line C1/E1, labelled with X-gluc shows a high level of GUS expression in the central infected region (a). Plate 33b, demonstrates the labelling is also in the inner cortex, as seen in the J₁D₁ line containing the same construct, although in this line there is apparently a higher level of GUS activity in the infected cell.



The localization of the GS/GUS mRNA by *In situ* hybridization, GUS protein localization by immunocytochemical staining and the localization of GUS enzyme activity by X-gluc staining is summarized in Table 8 on the following page. Results were obtained using intermediate to late stage nodules. *In situ* hybridizations were carried out on the most reproducible plant lines, therefore two of the less reproducible plant lines were only assayed for protein.

TABLE 8 . Summary of the mRNA and GUS protein levels in transgenic *L. corniculatus* root nodules at the intermediate to late stage of development.

Cell type	mRNA		
	β /GUS	γ /GUS (J ₁ D ₁)	γ /GUS (B ₁ B ₁)
I	-	+	++
NI	+	+	+?
IC	+	++	-
MC	-	-	-
OC	-	-	-
VE	++	+	-

PROTEIN				
	β /GUS	γ /GUS (J ₁ D ₁)	γ /GUS (B ₁ B ₁)	* γ /GUS (C ₁ E ₁)
I	-	+?	+	++
NI	+	++	+	+?
IC	+	+	-	+
MC	?	-	-	-
OC	-	-	-	-
VE	++	+	-	?

I-infected cells, NI-non infected cells, IC-inner cortex, MC-mid cortex
 OC-outer cortex, VE-vascular endodermis, *GUS enzyme activity measured by
 X-gluc staining.

6.2. DISCUSSION

6.2.1. The Expression of the GS/GUS gene Fusions in *L. corniculatis* Plants

A notable feature of the results summarized in Table 8 is that, despite the variations between the constructs, all of the lines containing the γ /GUS constructs (whether transcriptional or translational) showed detectable mRNA and protein levels. This was particularly evident at the earlier stages, in the infected cells of the nodule tissue, although neither mRNA nor protein was detected in the infected cells of the plant lines with the β /GUS constructs. Forde *et al.* (1989) reported that nodules containing the β /GUS construct stained with X-gluc showed staining throughout the nodule in the early stages of development. However they reported that this staining became confined to the vascular tissue only in the later stages of development. This same pattern of expression of the β /GUS mRNA and protein has been demonstrated in this thesis. The faint staining in the central region of the early nodules, reported by Forde *et al.* (1989), most likely corresponds to the staining of the non-infected cells. Forde *et al.* (1989) suggest "the intense staining associated with the vascular traces [in the β /GUS lines] may reflect higher overall transcriptional and translational activity in this region, and/or a greater cell density". The experiments with *P. vulgaris*, presented here, have demonstrated the vascular endodermal cells were areas of high transcriptional activity, particularly in mature nodules (Plate 19). Jefferson *et al.* (1987) demonstrated high levels of staining in the vascular tissue, in transgenic tobacco plants constitutively

expressing the GUS gene. Peterman *et al.* (1989), however suggested that intense X-gluc staining in vascular tissue may represent bad penetration of the X-gluc substrate into the tissue. This possibility cannot be excluded where whole nodules are stained as the thickening in the cell walls in the mid-cortex can form an intercellular diffusion barrier between the central and outer nodule tissue. The X-gluc staining of sections, and the *in situ* hybridization results presented here however, also show a high level of β /GUS mRNA in the vascular endodermal cells (Plate 28), which could cause the vascular traces to appear very dark in thick sections.

The results reported here show some differences between lines containing the γ /GUS translational fusion, although both lines showed conclusive evidence of γ /GUS mRNA in the infected cells, and all three lines had detectable levels of GUS protein or enzyme activity in the infected cells. The distribution of GUS activity demonstrated by the X-gluc staining in the B₁B₁ line by Forde *et al.* (1989), is consistent with the γ /GUS mRNA and protein distributions demonstrated here, although the higher resolution immunocytochemical technique showed some detectable GUS in the non-infected cells of the central region.

The variation between different lines demonstrated here is not unusual. Forde *et al.* (1989) reported considerable quantitative variation between different plant lines (from whom which these transgenic plants were obtained), and suggests that "some of the variability that we observe in organ-to-organ distribution of GUS activity in different lines carrying the same construct may be attributable to differences in the severity of the hairy root phenotype". Dean *et al.* (1988) also suggest that the variability, in

the overall expression in different cell lines with the same construct, is a well-established phenomenon in transgenic plants and does not seem to be related to the number of copies of the introduced gene, but is due to 'poorly understood positional effects'.

Despite the variation between different lines, all of the γ /GUS lines showed expression in the infected cells which was not seen in the β /GUS constructs. The differences between the two γ /GUS constructs seem unlikely to be responsible for the slightly different patterns of expression. The translational fusions (lines J,D₁, and C,E₁) both showed expression, although to slightly different extents, in the infected, non-infected, inner cortical, and vascular endodermal cells. Both γ /GUS constructs (as outlined in 1.4.5) contained 2 kb of the 5' flanking region of the *gln- γ* gene, but the translational fusions carried an additional 44 bp including 24 bp of the coding region. In the transcriptional fusion the translation initiation codon is supplied by the GUS gene. The plant line containing this transcriptional fusion (B,B₁) was found to have relatively higher levels of mRNA in the infected cells and less expression in the non-infected cells than in the other two γ /GUS lines.

If the difference in expression was due to these different constructs, rather than variation between the different lines, the transcriptional fusion with the GUS initiation codon, might be expected to show a less specific pattern of expression, than that of the translational fusion; this however was not the case.

6.2.2. Comparison of GS Expression in Chimaeric *L. corniculatus* and *P. vulgaris* plants

There are differences between *L. corniculatus* and *P. vulgaris* root nodules, which could influence the pattern of gene expression. Vance *et al.* (1982) reported that *L. corniculatus* nodules were of the spherical determinate type, the production of ureides and amides as export products had not to their knowledge been investigated. Therefore there may be metabolic differences between the *L. corniculatus* and *P. vulgaris* nodules.

The expression of the GUS genes determined by the *gln-β* and *gln-γ* 5' flanking regions generally show a very similar pattern to that demonstrated in *P. vulgaris*. In the β/GUS line no expression was detected in the infected cells, whilst high levels of β mRNA were detected in the infected cells of early *P. vulgaris* nodules. However early *L. corniculatus* nodules of a similar developmental stage were not examined in sufficient numbers, due to sectioning difficulties. Forde *et al.* (1989) did report some expression throughout the nodule in early β/GUS transgenic plants but they also reported that it was not possible to distinguish between the cell types. Intermediate stage *P. vulgaris* nodules have been demonstrated, in my study to have a reduced level of mRNA in the infected cells.

The expression of *gln-γ* in *P. vulgaris* follows a very similar pattern to that seen in the J₁D₁ line of the transgenic *L. corniculatus* plants, although there does seem to be some detectable expression in the vascular endodermal cells in *L. corniculatus* not seen in *P. vulgaris*. This is possibly due to the slightly different morphology of the two nodule types. The *P. vulgaris* vascular bundles are located on

the edge of the inner and mid-cortex, whilst those in *L. corniculatus* are apparently located in the middle of the inner cortex, where the *gln-γ* expression is high, in in both *P. vulgaris* the J₁D₁ and C₁E₁ *L. corniculatus* plant lines.

6.2.3. The Influence of the 5' flanking region on GS gene Expression

The pattern of expression of the *gln-γ* and *gln-β* genes in *P. vulgaris*, and that of the GUS gene controlled by the respective *P. vulgaris* promoters in the transgenic *L. corniculatus* plants, show remarkable similarity despite any morphological or metabolic differences and taking into account the possible variations between transformed lines. The two legume species apparently therefore respond to the same controlling elements within the 5' flanking regions of the GS genes.

Jensen *et al.* (1986) reported the expression of the soybean leghaemoglobin gene in transgenic *L. corniculatus* plants. They suggested that the nodule-specific expression was under the control of the 5' upstream region of the soybean gene and that it followed the correct developmental timing. De Bruijn *et al.* (1989) have cloned and sequenced the leghaemoglobin genes from the stem-nodulated tropical legume *Sesbania rostrata*. Fragments of this *S. rostrata* leghaemoglobin (*Srg1b3*) 5' upstream region were fused to the GUS reporter gene with either its own CAAT and TATA box promoter regions, or those of the cauliflower mosaic virus 35S promoters. The expression of GUS was then measured in leaves, roots and nodules of chimaeric *L. corniculatus* plants containing these constructs. They demonstrated the *Srg1b3* CAAT and TATA box promoter regions, together with 'upstream enhancer-type

elements' were essential for nodule-specific expression. Similarly Schmid *et al.* (1989) have demonstrated that tissue-specific expression of the *P. vulgaris* chalcone synthase gene was determined by its 5' flanking sequences.

The recognition of the same regulatory sequences in different legume species, such as *P. vulgaris* and *L. corincolatus* demonstrates how specific DNA sequences involved in nodule-enhanced expression of plant nodulation genes have been conserved throughout legume *Rhizobium* symbioses. These specific sequences are apparently induced by a putative bacteroid, or other form of metabolic or developmental signal. A similar common induction is demonstrated by the ability of some *Rhizobium* strains to cross inoculate and induce nodules in other legume species (Jensen *et al.*, 1986).

The homology between the cytosolic *P. vulgaris* GS genes has been established (Cullimore *et al.*, 1983; Lara *et al.*, 1984; Gebhardt *et al.*, 1986), and the divergence between the *gln-β* and *gln-γ* genes in the 5' flanking region reported (Cullimore and Bennett, 1988; Forde *et al.*, 1989; Forde and Cullimore, 1989). The divergence has been suggested to reflect, at least to some extent, the acquisition by each gene of distinct *cis*-acting elements that confer responsiveness to different sets of regulatory signals (Forde *et al.*, 1989).

It seems likely, on the basis of evidence already discussed, that the *cis*-acting regulatory elements will be identified within the 5' flanking regions of the GS *gln-γ* and *gln-β* genes.

7. DISCUSSION: THE EXPRESSION OF GS IN LEGUME ROOT NODULES

The development of *P. vulgaris* root nodules, has been described in Chapter 3, and the optimization and use of *in situ* hybridization techniques to investigate the differential expression of GS in developing nodules in Chapter 4. The results of these investigations and their possible implications are presented and discussed in Chapter 5, with further *in situ* results on transgenic *L. corniculatus* plants containing GS/GUS constructs presented and discussed in Chapter 6.

Reports of work on the expression and control of GS in developing root nodules of other legume species are discussed in this Chapter. They are considered with the results, presented here and elsewhere concerning the control and regulation of the expression of GS in developing *P. vulgaris* root nodules.

7.1. THE CONTROL OF GENE EXPRESSION IN OTHER NODULE SYSTEMS

Sengupta-Gopalan *et al.* (1986) reported that increased GS activity during nodule development in soybean was due to a novel set of four genes. These are detectable 11-12 days after infection and were reported to independent of nitrogen fixation. The root-specific GS, GS_r, and the nodule-specific, GS_n, were both shown to increase in activity during nodulation (Sengupta-Gopalan and Pitas, 1986). These observations correspond with the increase in GS_n and the isoforms of GS_r during *P. vulgaris* nodule development. Both GS_r and leghaemoglobin in soybean were shown to follow a different pattern of expression when

with the nine other soybean nodulins. This led Sengupta-Gopalan and Pitas (1986) to suggest that the GS and leghaemoglobin genes were not under the same control mechanism as the other nodulins.

Tingey *et al.* (1988) demonstrated an increase in pea root GS by approximately 20-fold during nodulation. They identified three polypeptides responsible for this increase, which they demonstrated arose from three different translational products encoded by three homologous, but distinct nuclear genes, which they collectively termed GS_n. These genes represent another small multigene family, similar to those in *P. vulgaris* and soybean. The products of the pea multigene family, although considerably increased in nodules, are also found at a lower level in other tissues, and are therefore nodule-enhanced rather than nodule-specific. This is a similar situation to that in *P. vulgaris*. A cytoplasmic GS polypeptide has been shown to increase dramatically during nodulation in alfalfa (Tischer *et al.*, 1986). Dunn *et al.* (1988) have isolated the cDNA for this polypeptide from a nodule library but did not determine whether it was nodule-enhanced or specific.

Evidence from other legume species therefore suggests that there is a similar increase in one or more GS isoforms during nodulation to that demonstrated in *P. vulgaris*.

7.2. THE CONTROL OF GS GENE EXPRESSION IN *P. vulgaris*

In nitrogen-fixing bacteria the problem of regulating the expression of the structural genes encoding GS has been solved by the use of tandemly-arranged promoters which are active under different conditions of nitrogen nutrition (Dixon, 1984). The GS multigene families provide evidence that higher plants may have adopted the alternative solution of evolving a set of independently regulated structural genes, at least some of which appear to have functionally similar coding sequences.

The control of the expression of these GS genes still remains an intriguing question, and one to which answers could provide important insights into the control of plant gene expression.

The histochemical results presented in this thesis have demonstrated that the formation of the different GS isoenzymes during nodulation is at least partially determined by;

1. the 5' flanking regions encoding isoenzyme subunits, and
2. the differential, spatial and temporal expression of the genes encoding the isoenzyme subunits.

The influence of these 5' flanking regions of the GS genes is considered below in 7.2.1., the way in which these flanking regions may interact with developmental 'signals' to induce the expression of these genes is considered in 7.2.2, and the influence of the spatial and temporal expression of the genes over the resultant isoenzyme composition considered in 7.2.3.

7.2.1. The Influence of Gene Structure on the Expression of GS

Results of studies on GS in legumes all suggest that changes in GS mRNA levels are reflected in the polypeptide levels and therefore, the regulation of these genes is primarily at the transcriptional level (Auger and Verma, 1981; Padilla *et al.*, 1987; Bennett and Cullimore, 1988). However, as Forde and Cullimore (1989) suggest, this assumption must be treated with caution, as changes in steady state levels of mRNA may also reflect post-transcriptional events occurring during mRNA synthesis in the nucleus and/or changes in mRNA stability.

The ability of the 5' flanking region to confer developmental expression of the *gln- γ* and *gln- β* GS genes in *P. vulgaris* was demonstrated in Chapter 6. Reports of the regulatory influence of the 5' flanking regions in other instances of nodule-enhanced expression have also been discussed (Jensen *et al.*, 1986; deBruijn *et al.*, 1989; Schmid *et al.*, 1989).

Forde and Cullimore (1989) reported from sequencing information that the three cytosolic GS genes show putative TATA box sequences (TATAAT/A) approximately 30 bp upstream of the major capsites, but they also reported that the rest of the 5' flanking regions of the GS cytosolic genes were poorly conserved. The former corresponds to the essential TATA and CAAT sequences identified by de Bruijn *et al.* (1989) to be responsible for the nodule-specific regulation of leghaemoglobin genes in *S. rostrata*. Mauro *et al.* (1985) identified putative regulatory elements in the 5' flanking regions of three nodule-specific genes in soybean. De Bruijn *et al.* (1989) reported that there was considerable homology between these elements identified in soybean and those in *S. rostrata*. Verma *et al.* (1986) reported that out of the

four nodulin genes encoding leghaemoglobin in soybean, all except one (nod 35) shared three regions of homology in their 5' ends, and they suggested that it was unlikely that this was a chance occurrence.

Verma *et al.* (1986) suggested that the presence of these short sequences, common to the 5' flanking regions of genes, may provide a structural basis for induction, as is the case with heat shock genes in *Drosophila* and the yeast histidine gene. Other eukaryotic developmental genes have been reported to have 5' regulatory elements such as the glucocorticoid regulatory genes (Cochet *et al.* 1982), and the steroid induced genes (Gray *et al.*, 1981).

Evidence therefore seems to suggest that short conserved regions in the 5' flanking regions, or *cis*-acting elements, in a number of nodule-specific genes, are at least partially responsible for their regulation. Forde and Cullimore (1989) suggest that, now they have cloned the *gln-γ* gene in *P. vulgaris*, it will be interesting to investigate whether different *cis*-acting regulatory elements are responsible for expression in different organs. However, if *cis*-acting elements are to regulate nodule-specific, (or nodule-enhanced) expression, the corresponding *trans*-activator molecules still need to be identified.

Verma *et al.* (1986) have demonstrated that the transcription of nodulins 23 and 24 in soybean begins at the same time, which they suggest provides a rationale for 5' *cis*-sequences being capable of binding the same *trans*-activator molecules. They suggest that infection by, or some product from, the micro-symbiont may produce the required *trans*-activator molecule, this could also be the case in *P. vulgaris*.

7.2.2. Factors Involved in the Induction of GS genes in Root Nodules

The use of rhizobial mutants, capable of initiating various stages of nodule development, have been used to demonstrate the requirement for certain stages of nodulation to be achieved for the full or partial induction of various genes. Lara *et al.* (1984) demonstrated fix^- mutants of *R. phaseoli* induced nodules which exhibited less than 5% the normal GS_{n1} activity, and 50% the normal GS_{n2} activity. Padilla *et al.* (1987) demonstrated that the GS γ polypeptides appeared three days before nitrogenase activity, and were therefore at least partially independent of dinitrogen fixation. Nodule specific/enhanced GS genes have however been shown not to be expressed in fix^- nodules, in which the bacteria do not penetrate cells, or in nodules lacking elongate bacteroids, but are induced in fix^- nodules containing differentiated bacteroids (Dunn *et al.*, 1988; Norris *et al.*, 1988).

Such observations with rhizobial mutants support the suggestion by Padilla *et al.* (1987) that the invasion of the cells by bacteria, and possibly the differentiation of the bacteroids is required for the induction, or at least partial induction, of nodule specific/enhanced genes.

The development of a complex organ such as the root nodule apparently has no single, simple, induction mechanism, although invasion by the bacteroids is evidently important, but not the only factor involved. Verma and Bal (1976) demonstrated that ineffective soybean nodules produced by three different *Rhizobium* strains, induced very different levels of expression of the leghaemoglobin genes. Auger and Verma (1981) suggested that nodule-specific sequences, present at variably-reduced concentrations in nodules induced by the different

mutants, could be a result of nitrogen starvation, and/or a lower proportion of infected cells than in normal nodules. However, this would be expected to affect all nodulins, but it only selectively affected leghaemoglobin and nodule-specific GS in the soybean.

Sengupta-Gopalan and Pitas (1985) demonstrated that fix *Rhizobium*, which induced fix⁻ root nodules in which no peribacteroid membrane was formed, induced the leghaemoglobin genes lb_{α} , lb_{β} and lb_{γ} in soybean but not GS₁₁. Therefore leghaemoglobin and GS are not necessarily induced by the same elements.

The transcription of GS in soybean has been shown to be stimulated by the availability of ammonia produced by dinitrogen fixation (Sengupta-Gopalan and Pitas, 1985). Hirel *et al.* (1987) have also demonstrated that ammonia is important, although not the primary effector in the induction of GS in *P. vulgaris* and may be probably involved in the magnitude and maintenance of expression rather than its initial induction. In contrast to these reports, Corruzzi *et al.* (1989) have demonstrated that in peas *nif D* rhizobial mutants, which induce nodules lacking in nitrogenase, still accumulated GS mRNA to the normal levels; the GS genes do not therefore seem to dependent on the accumulation of ammonia in this case.

Other studies have been conducted on the effect of ammonium by growing nodules in an environment of 80% argon and 20% oxygen. In such an environment nitrogenase is produced but no ammonia, only hydrogen (Atkins *et al.*, 1984; Hirel *et al.*, 1987). *P. vulgaris* plants grown under these conditions were shown to contain 22% GS₁₁, and 65% normal GS₁₂ levels. Similarly Hirel *et al.* (1987) demonstrated that although GS levels were significantly reduced in soybean under these conditions,

leghaemoglobin levels were normal until the late stages. They also demonstrated that the addition of ammonium to soybean roots, previously starved of nitrogen, resulted in an increase in cytosolic GS mRNA within eight hours, whilst the addition of nitrate produced no effect. Cock *et al.* (1989) reported that this effect was not however seen in *P. vulgaris*. The exogenous application of ammonium salts to nodules has been reported to induce early nodule senescence (Vezina *et al.*, 1989) and therefore cannot be used to test out the possible induction of $\text{gln } \gamma$ mRNA in nodules by ammonia.

From such experiments it seems evident that bacteria are either directly or indirectly involved in the induction of nodule-specific/enhanced genes. The penetration and bacterial release appear to be important factors; whether this relates to the release of *trans*-acting factors, which bind to *cis*-acting elements in order to induce specific genes, has yet to be established.

The influence of hormones in GS gene induction cannot be ruled out, Auger and Verma (1981) suggested that the increase in concentration of commonly or moderately abundant sequences appeared to be moderated by auxins, whilst Corruzzi *et al.* (1989) also suggested that GS_n in pea root nodules could be at least partly regulated by hormones. Scheres *et al.* (1989), and Schmid *et al.* (1989), have also demonstrated that early nodulin genes can be induced by hormones.

In summary, it appears that at a transcriptional level of regulation, *cis*-acting elements in the 5' flanking regions of nodule-specific/enhanced genes may respond to *trans*-acting factors, associated with invading rhizobia, and/or development signals, which then in combination initiate the gene induction. Other major regulatory

compounds such as ammonia appear to play a key role, possibly in the magnitude or maintenance of expression. With some insight into the control of nodule specific/enhanced gene expression at the transcriptional level, the possible controls at the polypeptide and isoenzyme levels can be considered.

7.2.3. The Temporal and Spatial Control of GS Isoenzyme Assembly

The temporal and spatial expression of the three cytosolic GS mRNAs was demonstrated in Chapter 5, and the way in which this temporal and spatial expression could determine the isoenzyme composition in a particular cell type within a root nodule was discussed.

On the basis of the *L. corniculatus* histochemical data, Forde *et al.* (1989) suggested that some cells such as the infected cells synthesize both γ and β polypeptides, whilst others synthesize only β polypeptides. This spatial separation of the polypeptides may at least partially determine their assembly into isoenzymes. From the results reported here on the expression of GS in *P. vulgaris* and *L. corniculatus* it seems the GS isoenzyme assembly is at least partially controlled by a temporal and spatial separation of the subunits.

The early expression of the β polypeptide at higher levels than γ , would lead to the formation of $GS_{\gamma\beta}$. As the γ gene is then expressed at increasingly high levels in the infected, non-infected and inner cortical tissue, the ratio of γ : β increases and is reflected in the isoenzyme composition of $GS_{\gamma\gamma}$. The early decline in the expression of the *gln- β* gene in the infected cells, as demonstrated in Chapters 5 and 6, would also contribute to the high ratio of γ : β , which on this basis would be expected to be higher in the infected cells, than the non-

infected and cortical cells. The possible involvement of the α polypeptide has been discussed in Chapter 5.

On the basis of the results presented here it seems likely that in nodules which are actively fixing nitrogen the γ polypeptide is at its highest levels in the infected cells and present at lower levels, or absent in the mid and outer-cortical cells, where the levels of ammonia assimilation would be expected to be significantly lower, i.e. the γ polypeptide may be required in the highest ratios to cope effectively with the conditions in the infected cells, whilst in the cortical tissues the conditions are such that a lower level of γ and higher level of β polypeptides form the optimum isoenzyme. The outer-cortical and root tissue provide the conditions in which the β_{10} , or GS₁₀ isoenzyme functions best.

Similar temporal and spatial expression of other nodule-specific/enhanced genes have been reported. Verma *et al.* (1976) reported there was a time difference between the appearance of two major electrophoretically-distinguishable forms of leghaemoglobin in soybean. As well as being expressed at different stages of nodulation, they were shown to have different turnover rates, although the authors were unable to determine whether the expression also differed spatially.

The suggestion by Cullimore and Bennett (1988) that polypeptides with different properties may be required in different subcellular compartments, has now been demonstrated by the results presented in this thesis and those reported by Forde *et al.* (1989), and at least partially determine the resultant isoenzyme composition.

A complete elucidation of the complex gene control and expression

particularly that of GS in *P. vulgaris*, involved in nodule development is getting closer and will provide important insights into the control and regulation of plant gene expression.

7.3. FUTURE WORK

The results presented here provided a basis on which to extend both the *in situ* histochemical techniques and their application in studies of gene expression during legume root nodule development.

7.3.1. Further Use of *in situ* Hybridization Techniques

Techniques for *in situ* hybridizations on legume root nodules have been established and the various parameters discussed in Chapter 4. These techniques could now be developed further by:

1. extending the *in situ* hybridization techniques to the electron microscope level, to allow more detailed studies on the cellular location of mRNA.
2. developing a more reproducible silver detection method, which may provide a more specific localization of mRNA than alkaline phosphatase.
3. investigating alternative methods of probe labelling, particularly where tissues being studied contain high levels of biotin.

7.3.2. Further Investigations into Gene Expression in Legume Root Nodules

The investigations into the temporal and spatial expression of GS in developing *P. vulgaris* root nodules could be expanded in many ways. These include:

1. investigating the temporal and spatial expression of GS in ineffective *P. vulgaris* root nodules.

2. investigating the possible differential expression of the GS genes in developing embryos of *P. vulgaris*
3. investigating the expression of GS in root nodules of other legume species such as soybean and pea.
4. extending the work reported by Vanden-Bosch and Newcomb (1988), by investigating the temporal and spatial distribution of leghaemoglobin mRNAs in soybean.

8. SUMMARY

A survey of the structural development of *P. vulgaris* nodules was undertaken and acted as a basis for subsequent histochemical localization of the transcription and translation products of GS gene expression. Each stage of tissue preparation for histochemical work was optimized including fixing, sectioning and embedding methods were considered in depth to find an optimum, which combined with the prehybridization and hybridization treatments produced a reliable and reproducible *in situ* hybridization method. Suitable cRNA probes were prepared and methods of non-isotopic labelling and detection investigated. The optimized *in situ* hybridization method, using photobiotin labelled cRNA probes and alkaline phosphatase or streptavidin gold enhanced with silver, methods of visualization were applied to *P. vulgaris* root nodule sections. In combination with immunocytochemical protein localization techniques, the differential temporo-spatial expression of the GS polypeptides in *P. vulgaris* was demonstrated:

The *gln- α* gene is expressed at a low level in all but the rhizobially infected cells throughout nodule development. The *gln- β* gene is expressed at a high level during early nodule development, but becomes confined to the vascular endodermal and cortical tissues in the late stages of nodulation. The *gln- γ* gene expression is concentrated in the central infected, non-infected and inner-cortical tissues in early nodules, and becomes confined to the inner cortex only in the late stages of nodulation.

The same *in situ* histochemical techniques were adapted, and used to demonstrate the 5' flanking regions of the *P. vulgaris* GS genes fused to the GUS reporter gene in *L. corniculatus* showed a similar pattern of temporal and spatial expression.

On the basis of these results obtained by *in situ* hybridization, it can be suggested that the differential temporo-spatial expression of the *P. vulgaris* GS mRNA and polypeptides may determine the isoenzyme composition within a particular cell type.

The expression of these genes encoding the GS polypeptides is at least partially determined by their 5' flanking regions, as demonstrated in the transgenic *L. corniculatus* plants. The controlling elements within this flanking region may be localized to putative *cis*-acting elements which respond to nodule developmental signals and the production of ammonia.

Acknowledgements: I would like to thank Prof. D. Boulter for the use of the facilities in Durham, and Dr. P. Shewry for the use of the facilities in at The Institute of Arable Crops Research in Harpenden

Above all thanks are due to my supervisor Dr. Nick Harris for his help, advice and endless reading of this thesis, and Dr. Brian Forde for his help with the preparation of probes, providing the transgenic *L. corniculatus* plants and his constructive reading of this thesis. I would like to thank Dr. J. Cullimore, and Dr. Martin Watson for providing the GS and GUS antibodies respectively, Margaret Gibbs for providing the GUS cDNA probe, Helen Grindley for her technical advice and assistance in Durham and John Davies for his painstaking work on with the graphs and diagrams in this thesis.

I am grateful to the Science and Engineering Research Council for providing the grant to carry out this work. Many thanks go to all friends and colleagues who have provided help and support over the last three years and particularly to the Madeley family who have provided support encouragement and a very welcome retreat. Finally this thesis would be incomplete without a mention of my constant companion (and paper shredder) throughout the struggle to write this thesis; Spicey rabbit.

9. REFERENCES

- Angerer L.M. and Angerer R.C. (1981). Detection of poly A⁺ RNA in sea urchin eggs and embryos by quantitative *in situ* hybridization. *Nuc. Acids Res.* 9, 2819-2840.
- Angerer L.M., Cox K.H., Angerer R.C., (1987). Demonstration of tissue-specific gene expression by *in situ* hybridization. *Methods in Enzymology.* 152, p649.
- Arakaki Y., Toyoda H., Watanab S., Seki S., Oda T. (1988). Detection of hepatitis B virus-DNA in liver tissues in chronic type B liver diseases and its relevancy to viral antigens: A study by *in situ* hybridization using a biotinylated probe and streptavidin alkaline phosphatase. *Acta Histochem. Cytochem.* 21 (5), 489-498
- Albrecht S.L., Maier R.J., Hanus F.J., Russell S.A., Emerich D.W., Evans H.J. (1979). Hydrogenase in *R. japonicum* increases nitrogen fixation by nodulated soybeans. *Science* 203 (4386), 1255-1257.
- Atkins C.A., Shelp B.J., Storer D.J., Pate J.S. (1984). Nitrogen nutrition and the development of biochemical functions associated with nitrogen fixation and ammonia assimilation of nodules on cowpea seedlings. *Planta* 162 327-333.
- Auger S. and Verma D.P.S., (1981). Induction and expression of nodule-specific host genes in effective and ineffective root nodules of soybean. *Biochemistry* 20 (5), 1300-1306.
- Auger S., Baulcombe D., Verma D.P.S., (1979). Sequence complexities of the poly (A)-containing mRNA in uninfected soybean root and nodule tissue developed due to the infection by *Rhizobium*. *Biochem. Biophys. Acta.* 563 (2) 496-507.
- Awonaike K.O., Lea P.J., Miflin B.J. (1981). The location of the enzymes of ammonia assimilation in root nodules of *Phaseolus vulgaris* L. *Plant Science Letters* 23, 189-195.
- Bauer W.D., (1981). Infection of legumes by *Rhizobium*. *Ann. Rev. Plant Physiol.* 32, 407-449.
- Bennett M.J., Lightfoot D.A., Cullimore J.V. (1989). cDNA sequence and differential expression of the gene encoding glutamine synthetase γ encoding polypeptide of *Phaseolus vulgaris* L. *Plant Molec. Biol.* 12 (5), 553-65.
- Bergersen F.J. (1974). Formation and function of bacteroids. In: *The Biology of Nitrogen Fixation.* (ed. Quispel A.) pp473-498. North-Holland. Amsterdam.
- Bergersen F.J. (1977). Section III. In: *A Treatise on Dinitrogen Fixation.* (ed. Hardy R.W.F. and Silver W.S.). pp519-555. Wiley. New York.
- Bergersen F.J. (1982). *Root nodules of legumes: Structure and Function.* pp164. Chichester. Research Studies Press.

- Bergersen F.J. and Goodchild D.J. (1973a). Aeration pathways in soybean root nodules. *Aust. J. Biol. Sci.* 26 (4) 729-740.
- Bergersen F.J. and Goodchild D.J. (1973b). Cellular location and concentration of leghaemoglobin in soybean root nodules. *Aust. Journal Biol. Sci.* 26 (4), 741-756.
- Bergersen F.J. and Turner G.L. (1967). Nitrogen fixation by the bacteroid fraction of breis of soybean root nodules. *Biochem. Biophys. Acta.* 141, 507-515.
- Bisseling T., Vanden Bos R.C., Weststrate M.W., Hakkaart M.J.J., VanKammen A. (1979). Development of the nitrogen fixing and protein-synthesizing apparatus of bacteroids in pea root nodules. *Biochimica et Biophysica Acta.* 562, 515-526.
- Bisseling T., Vanden Bos R.C., VanKammen A. (1977). Cytofluorometrical determination of the DNA contents of bacteroids and corresponding broth-cultured *Rhizobium* bacteria. *J. Gen. Microbiol.* 101 (1), 79-84.
- Boland M.J., Fordyce A.M., Greenwood R.M. (1978). Enzymes of nitrogen metabolism in legume nodules: A comparative Study. *Aust. Journal Plant Physiol.* 5, 553-559.
- Boland M.J. and Benny A.G. (1977). Enzymes of the nitrogenase metabolism in legume nodules. Purification and properties of NADH-dependent glutamate synthase from lupin nodules. *Eur. J. Biochem.* 79, 344-362.
- Brahic M. and Haase A.T. (1978). Detection of viral sequences of low reiteration frequency by *in situ* hybridization. *Proc. Nat. Acad. Sci. U.S.A.* 75 (12), 6125-6129.
- Bresser J. and Evinger-Hodge M.J. (1987). Comparison of *in situ* hybridization procedures yielding rapid, sensitive mRNA detections. *Gene Anal. Techniques.* 89-104.
- Brigati D.J., Myerson D., Leary J.J., Spalhorz B., Travis S.Z., Fong C.k.y., Hsiung G.D., Ward D.C. (1983). Detection of viral genomes in cultured cells and paraffin-embedded tissue sections using biotin-labelled hybridization probes. *Virology* 126, 32-50.
- Bulen W.A. and LeCompte T.R. (1966). The nitrogenase system from *Azobacter*: 2-enzyme requirements of nitrogen reduction, ATP dependent H_2 evolution and ATP hydrolysis. *Proc. Nat. Acad. Sci. U.S.A.* 56, 979-986.
- DeBruijn E.J., Dehio G., Felix G., Goel B., Grunenberg H.J., Hoffman H.J., Metz B., Ratet P., Stacey G., Szabodos L., Welters R., Schell J. (1989). *Cis*-acting elements and *trans*-acting factors involved in nodulin gene regulation. *EMBO Symposium* 1989. p12.
- Callaham D.A. and Torrey J.G. (1981). The structural basis for infection of root hairs of *Trifolium repens* by *Rhizobium*. *Can. J. Bot.* 59, 1647-1664.

- Chen F.L. and Cullimore J.V. (1989). Two isoenzymes of NADH-dependent glutamine synthase in root nodules of *Phaseolus vulgaris* L. Purification, properties and activity changes during nodule development. *Plant Physiol.* 88 (4), 1454-60.
- Chen J. and Kennedy I.R. (1985). Purification and properties of lupin nodule glutamine synthetase. *Phytochemistry* 24, 2167-2172.
- Childs G.V., Lloyd J.M., Unabia G., Ghard S.D., Wierman M.E., Chin W.W. (1987). Detection of luteinizing hormone β mRNA in individual gonadotrophs after castration: Use of a new *in situ* hybridization method with a photobiotinylated complementary RNA probe. *Molec. Endocrinol.* 1 (12), 926-933.
- Cochet M., Chang A.C.Y., Cohen S.N. (1982). Characterization of the structural gene and putative 5'-regulatory sequences for human proopiomelanocortin. *Nature* 297, 335-339.
- Comai L., Dietrich R.A., Maslyar D.J., Baden C.S., Harada J.J. (1989). Co-ordinate expression of transcriptionally regulated isocitrate lyase and malate synthase genes in *Brassica napus*. *The Plant Cell* 1, 293-300.
- Coruzzi G.M., Edwards J.W., Tsai F-Y., Walker B., Brears T. (1989). Regulation of genes encoding enzymes along a common nitrogen metabolic pathway in plants. 16th EMBO Int. Symp. p20.
- Cox K.H., DeLeon D.V., Angerer L.M., Angerer R.C. (1984). Detection of mRNAs in sea urchin embryos by *in situ* hybridization using asymmetric RNA probes. *Developmental Biol.* 101, 485-502.
- Craig S. and Miller C. (1984). L.R. White resin and improved on-grid immunogold detection of vicilin, a pea seed storage protein. *Cell Biol. Int. Rep.* 8, 879-886.
- Cullimore J.V. and Mifflin B.J. (1983). Immunological studies on glutamine synthetase using antisera raised to the two plant forms of the enzyme from *Phaseolus* root nodules. *J. Exp. Bot.* 35 (153), 581-587.
- Cullimore J.V., Gebhardt C., Saarelainen., Mifflin B.J., Idler K.B., Barker R.F. (1984). Glutamine synthetase of *Phaseolus vulgaris* L. Organ-specific expression of a multigene family. *J. of Molec. and Appl. Genetics* 2, 589-599.
- Cullimore J.V. and Bennett M.J. (1988). The molecular biology and biochemistry of plant glutamine synthetase from root nodules of *Phaseolus vulgaris* L. and other legumes. *J. Plant Physiol.* 132/4, 387-393.
- Cullimore J.V., Lara M., Lea P.J., Mifflin B.J. (1983). Purification and properties of 2 forms of glutamine synthetase from the plant fraction of *Phaseolus* root nodules. *Planta* 157, 245-253.
- Cunningham S.D., Kapulnik Y., Kagan S.A., Brewin N.J., Phillips D.A. (1985). Uptake hydrogenase activity determined by pRL5J1 does not increase symbiotic nitrogen fixation. *Appl. Environ. Microbiol.* 50, 791-794.

- Dart P.J. (1975). Legume root nodule initiation and development. In: The Development and Function of Roots. (eds. Torrey J.G. and Clarkson D.T.). pp467-506. Academic Press, New York.
- Dart P.J. (1977). Infection and development of leguminous nodules. In: A Treatise on Dinitrogen Fixation. (eds. Hardy R.W.F. and Silver W.S.) pp367-472. Wiley, New York.
- Dean, C., Jones, J., Favreau, M., Dunsmuir, P., Bedbrook, J. (1988). Influence of flanking sequences on variability in expression levels of an introduced gene in transgenic tobacco plants. *Nuc. Acids Res.* 16, 9267-9283.
- Diaz C.L., Melchers., Hooykaas P.J., Lugtenberg B.J., Kijne J.W. (1989). Root lectin as a determinant of host-plant specificity in the *Rhizobium*-legume symbiosis. *Nature* 338, 579-581.
- Dietrich R.A., Maslyar D.J., Heupel R.C., Harada J.J. (1989). Spatial patterns of gene expression in *Brassica napus* seedlings: Identification of a cortex specific gene and localization of mRNAs encoding isocitrate lyase and a polypeptide homologous to proteinases. *The Plant Cell* 1, 73-80.
- Dilworth M.J. (1980). The leghaemoglobins. *Methods in Enzymology.* 62C, 812-23.
- Dilworth M.J. and Williams D.C. (1969). Nucleic acid changes in bacteroids of *Rhizobium lupini* during nodule development. *J. Gen. Microbiol.* 48 (1), 31-36.
- Dixon R.O.D. (1969). *Rhizobium*, (with particular reference to relationships with host plants). *Ann. Rev. Microbiol.* 23, 137-158.
- Dixon R.O.D. (1972). Hydrogenase in legume root nodule bacteroids. *Arch. Microbiol.* 85, 193-201.
- Dixon R.O.D. (1984). Hydrogenase in legume root nodule bacteroids: occurrence and properties. *Arch. Mikrobiol* 85, 193-201.
- Dixon R.O.D. and Wheeler C.T. (1986). In: Nitrogen Fixation in Plants. (Dixon R.O.D. and Wheeler C.T. eds.). Blackie. Glasgow and London.
- Djordjevic M.A., Redmond J.W., Batley M., Rolfe B.G. (1987). Clovers secrete specific phenolic compounds which either stimulate or repress *nod* gene expression in *Rhizobium trifolii*. *EMBO J.* 6 (5), 1173-1179.
- Downie J A. and Johnston A.W.B. (1988). Nodulation of legumes by *Rhizobium*. *Plant Cell and Environ.* 11, 403-412.
- Dunn K.R., Dickstein R., Feinbaum R., Burnett B.K., Peterman T.K., Thoidis G., Goodman H.M., Ausbel F.M. (1988). Developmental regulation of nodule-specific genes in alfalfa root nodules. *Molec. Plant-Microbe Interact.* 1, 66-75.
- Evans H.J. and Barber L.E. (1977). Biological nitrogen fixation for food and fiber production. *Science* 197, 332-339.

Evans H.J., Bottomly P.J., Newton W.E. (1985). Nitrogen fixation research progress. Proc. 6th Int. Symp. on nitrogen fixation, Corvallis Oregon. Dordrecht: Martinus Nihoff.

Evans H.J., Emerich D.W., Ruiz-Argueso J., Maier R.J., Albrecht S.L. (1979). In: Proceedings of the Steenbock-Ketterneg International Symposium on nitrogen fixation. (Orme-Johnson W.H. and Newton W. eds.). Univ. Park Press, Baltimore, Maryland.

Evans H.J., Zuber M., Dalton D.A. (1987). Some processes related to nitrogen fixation in nodulated legumes. Phil. Trans. Royal Soc. Lond. B. 317 (67), 209.

Farria S.M.de, Sutherland J.M. and Sprent J.I. (1986). A new type of infected cell in root nodules of *Andira* Spp. (Leguminosae). Plant Sci. 45, 143-147.

Firmin J.L., Wilson K.E., Rossen L., Johnston A.W.B. (1986). Flavanoid activation of nodulation genes in *Rhizobium* reversed by other compounds present in plants. Nature 324, 90-92.

Forde B.G. and Cullimore J.V: The molecular biology of glutamine synthetase in higher plants. Oxf. Surveys Plant Molec. Cell Biol. in press (1989).

Forde B.G., Day H.M., Turton J.F., Wen-Jun S., Cullimore J.V., Oliver J.E. (1989). Two glutamine synthetase genes from *Phaseolus vulgaris* L. Display contrasting developmental and spatial patterns of expression in transgenic *Lotus corniculatus* plants. The Plant Cell. 1, 391-401.

Forster A.C., McInnes J.L., Skingle D.C., Symons R.H. (1985). Non-radioactive hybridization probes prepared by the chemical labelling of DNA and RNA with a novel reagent-photobiotin. Nuc. Acids. Res. 13, p745

Frazer H.L. (1942). The occurrence of endodermis in leguminous root nodules and its effect upon nodule function. Proc. Royal Soc. Edinburgh B. LXI 1941-1943, p328-8.

Gall J.G. and Pardue M.L. (1969). Formation and detection of RNA-DNA hybrid molecules in cytological preparations. Proc. Nat. Acad. Sci. U.S.A. 63, 378-383.

Gasser C.S., Bubelien K.A., Smith A.G., Shah D.M., Fraley R.T. (1989). Isolation of tissue -specific cDNA from tomato pistils. The Plant Cell. 1, 15-24.

Gebeyehu G., Rao P.Y., Soochan P., Simms P.A., Klevan L. (1987). Novel biotinylated nucleotide-analogs for labelling and colorimetric detection of DNA. Nuc. Acids Res. 15 (11), 4513-4534.

Gebhardt C., Oliver J.E., Forde B.G., Saarelainen R., Mifflin B.J. (1986). Primary structure and differential expression of glutamine synthetase genes in nodules, roots and leaves of *P. vulgaris*. EMBO. J. 5 (7), 1429-1435.

Godard C.M. (1983). Improved method for detection of cellular transcripts by *in situ* hybridization. Histochemistry 77, 123-131.

- Godard C.M. and Jones K.W. (1978). An improved method for the detection of cellular transcripts by *in situ* hybridization: Detection of polyadenylic acid sequences in individual cells. *Histochemistry*. 65 (3), 291-300.
- Godfrey C.A., Coventry D.R., Dilworth M.J. (1975). In: Nitrogen Fixation by Free-living Micro-organisms, (Stewart W.D.P., ed.). Internat. Biological Programme, 6, 311-382. Cambridge University Press.
- Goldberg R., (1986). Manual For *In situ* Hybridization. Not Published.
- Goodchild D.J. (1977). The ultrastructure of root nodules in relation to nitrogen fixation. *Int. Rev. Cytol. Supp.* 6, 235-289.
- Goodchild D.J. and Bergersen F.J. (1966). Electron microscopy of the infection and subsequent development of soybean nodule cells. *J. Bacteriol.* 92 (1), 204-213.
- Graham P.H., Bale J., Baker D., Fried M., Rokoski J., Mackay K.T., Craswell E. (1988). The contribution of biological nitrogen fixation to plant production: An overview of the symposium and its implications. *Plant and Soil*, 1988, pi-6.
- Graham R.C. and Karnovsky M.J. (1966). The early stages of absorption of injected horseradish peroxidase in the proximal tubules of mouse kidney: Ultrastructural Cytochemistry by a new technique. *J. Histochem. cytochem.* 14, 291-302.
- Gray D.M., Liu J-J., Railiff R.I., Allen F.S. (1981). Sequence dependence of the circular dichroism of synthetic double stranded RNAs. *Biopolymers* 20, 1337-1382.
- Groat R.G. and Schrader L.E. (1982). Isolation and immunochemical characterization of plant glutamine synthetase in alfalfa (*Medicago sativa* L.) nodules. *Plant Physiol.* 70, 1759-1761.
- Groat R.G. and Vance C.P. (1981). Root nodule enzymes of ammonia assimilation in two plant conditioned symbiotically ineffective genotypes of alfalfa. *Plant Physiol.* 69 (3), 614-618.
- Grunstein M. and Hogness D.S. (1975). Colony hybridization: A method for the isolation of cloned DNAs that contain a specific gene. *Proc. Nat. Acad. Sci. U.S.A.* 73, 3146-3150.
- Guitteny A.F., Fouque B., Mougin C., Teoule R., Bloch B. (1988). Histological detection of messenger RNAs with biotinylated synthetic oligonucleotide probes. *J. Histochem. and Cytochem.* 36 (6), 563-571.
- Haack A. (1964). Über den Einfluss der knöllchenbakterien auf die Wurzelhaare von Leguminosen und nicht Leguminosen. *Zentralbl. Bakteriol. Parasit enkd Infektionstr. Abt. II*, 117, 343-366.
- Hafen E., Levine M., Garber R.L., Gehring W.J. (1983). An improved *in situ* hybridization method for the detection of cellular RNAs in *Drosophila* tissue sections and tis application for localizing transcripts of the homoetic *antennapedia* gene complex. *EMBO J.* 2 (4), 617-623.

- Hanks J.F., Schubert K., Tolbert N.E. (1983). Isolation and characterization of infected and uninfected cells from soybean nodules. *Plant Physiol.* 71, 869-873.
- Hanks J.F., Tolbert N.E., Schubert K.R. (1981). Localization of enzymes of ureide biosynthesis and microsomes of nodules. *Plant Physiol.* 68, 65-69.
- Harker A.R., Lambert G.R., Hanks F.J., Evans H.J. (1984). Some properties of the nickel containing hydrogenase of chemolithotrophically grown *Rhizobium japonicum*. *J. Bact.* 159, 850-856.
- Harker A.R., Lambert G.R., Hanks F.J., Evans H.J. (1985). Further evidence that 2 unique subunits are essential for expression of hydrogenase activity in *Rhizobium japonicum*. *J. Bact.* 164, 187-191.
- Harper M.E., Marsell L.M., Gallo R.G., Wong-Staal F. (1986). Detection of lymphocytes expressing human T-lymphotropic virus type III in lymph nodes and peripheral blood from infected individuals by *in situ* hybridization. *Proc. Nat. Acad. Sci. U.S.A.* 83 p772.
- Harris N. and Croy R.R.D. (1986). Localization of mRNA for pea legumin: *In situ* hybridization using biotinylated cDNA probes. *Protoplasma* 130, 57-67.
- Harris N., Grindley H., Mulchrone J., Croy R.R.D. (1989). Correlated *in situ* hybridization and immunochemical studies of legumin storage protein deposition in pea (*Pisum sativum* L.). *Cell Biol. Int. Rep.* 13(1), 23-35.
- Harrison-Murray R.S., Clarkson D.J. (1973). Relationships between structural development and absorption of ions by the root system of *Cucurbita pepo*. *Planta* 114, 1-16.
- Hirel B., Bouet C., King B., Layzell D., Jacob F., Verma D.P.S. (1987). Glutamine synthetase genes are regulated by ammonia provided externally or by symbiotic nitrogen fixation. *EMBO. J.* 6 (5), 1167-1171.
- Hirel B., McNally S.F., Gadai P., Sumar N., Stewart G.R. (1984). Cytosolic glutamine synthetase in higher plants. A comparative immunological study. *Eur. J. Biochem.* 138, 63-66.
- Holmes D.S. and Quigley M. (1981). A rapid biological method for the preparation of bacterial plasmids. *Anal. Biochem.* 114, 193-197.
- Ingelbrecht J.L.W., Herman L.M.F., Dekeyser R.A., Montagu M.C.V., Deficker A.G. (1989). Different 3' end regions strongly influence the level of gene expression in plant cells. *The Plant Cell.* 1, 671-680.
- Jefferson R.A., Kavanagh T.A., Bevan M.W. (1987). GUS fusions: β -glucuronidase as a sensitive and versatile gene fusion marker in higher plants. *EMBO. J.* 6 (13), 3901-3907.
- Jensen E. O., Marcker K.A., Schell J., DeBruijn F.J. (1988). Interaction of a nodule specific *trans*-acting factor with distinct DNA elements in the soybean leghaemoglobin *lbc*, 5' upstream region. *EMBO. J.* 7 (5), 1265-1271.

Jensen J.S., Marcker K.A., Otten L., Schell J. (1986). Nodule-specific expression of a chimaeric soybean leghaemoglobin gene in transgenic *Lotus corniculatus*. *Nature* 321, 669-674.

John H.A., Birnstiel M.L., Jone K.W. (1969). RNA-DNA hybrids at the cytological level. *Nature* 223, 582-587.

Johnston A.W.B., Downie J.A., Rossen L., Shearman C.A., Firmin J.I., Borthakur D., Wood E.A., Bradley D., Brewin N.J. (1987). Molecular analysis of the *Rhizobium* genes involved in the induction of nitrogen-fixing nodules on legumes. *Phil. Trans. R. Soc. Lond. B.* 317 (67), 193-205.

Jorgensen J.E., Stougaard J., Marcker A., Marcker K.A. (1988). Root nodule-specific gene regulation: Analysis of the soybean nodulin N23 gene promoter in heterologous symbiotic systems. *Nuc. Acids Res.* 16 (1), 39-50.

Khandjian E.W. (1987). Optimized hybridization of DNA blotted and fixed to nitrocellulose and nylon membranes. *Bio/Technology* 5, 165-166.

Knight T.J., Bush D.R., Langston-Unkefer P.J. (1988). Oats tolerant of *Pseudomonas syringae* pv. *tabaci*. Contain tabtoxicine- β -Lactam, insensitive leaf glutamine synthetases. *Plant Physiol.* 88, 333-339.

Knight T.J. and Langston-Unkefer P.J. (1988). Enhancement of symbiotic dinitrogen fixation by a toxin-releasing plant pathogen. *Science* 241, 951.

Konieczny A., Szczyglowski K., Boron L., Przybylska M., Legocki A.B. (1988). Expression of lupin nodulin genes during root nodule development. *Plant Sci.* 55, 145-149.

Landsman J., Dennis E.S., Higgins T.J.V., Appleby C.A., Kortt A.A., Peacock W.J. (1986). Common evolutionary origin of legume and non-legume plant haemoglobins. *Nature* 324, 166-168.

Lara M., Cullimore J.V., Lea P.J., Mifflin B.J., Johnston A.W.B., Lamb J.W. (1984). Appearance of a novel form of plant glutamine synthetase during nodule development in *Phaseolus vulgaris* L. *Planta* 157, 254-258.

Lara M., Ortega J.L., Olguin B.E., Sanchez F. (1988). Nodulin expression and nitrogen metabolism in *Phaseolus vulgaris* root nodules. In: Bothe H., DeBruijn F.J., Newton W.E. eds. *Nitrogen fixation: A hundred years after*. Stuttgart, Gustav-Fischer Verlag pp617-622.

Lara M., Porta H., Padilla J., Folch J., Sanchez F. (1984). Heterogeneity of glutamine synthetase polypeptides in *Phaseolus vulgaris*. *Plant Physiol.* 76 (4), 1019-1023.

Larsson L-I., Christensen T., Dalboge H. (1988). Detection of propiomelanocortin mRNA by *in situ* hybridization using a biotinylated oligodeoxynucleotide probe and avidin-alkaline phosphatase histochemistry. *Histochemistry* 89, 109-116.

- LaRue T.A., Peterson J.B., Tajima S. (1984). Carbon metabolism in the legume nodule. In: Veeger C. and Newton W.E. eds: Advances in nitrogen fixation research, Nijhoff, The Hague. pp437-443.
- Lathe R. (1984). Synthetic oligonucleotide probes deduced from amino acid sequence data: Theoretical and practical considerations. J. Molec. Biol. 183, 1-12.
- Lawrie A.C. and Wheeler C.T. (1975). Nitrogen fixation in the root nodules of *Vicia faba* L. in relation to the assimilation of carbon II. The dark fixation of carbon dioxide. New Phytol. 74, 437-445.
- Libbenga K.R. and Bogers R.J. (1974). Root nodule morphogenesis. In: The biology of nitrogen fixation. A. Quispel ed. Amsterdam: North-Holland. pp430-472.
- Leary J.J., Brigati D.J., Ward D.C. (1983). Rapid and sensitive colorimetric method for visualizing biotin-labelled DNA probes hybridized to DNA or RNA immunobilized on nitrocellulose: Bio-blots. Proc. Nat. Acad. Sci. U.S.A. 80, 4045-4049.
- Lebacqz P., Squalli D., Duchene M., Pouletty P., Joannes M. (1988). A new sensitive non-isotopic method using sulfonated probes to detect picogram quantities of specific DNA sequences on blot hybridizations. J. Biophys. Biochem. Meth. 15 p255.
- Lehtovaara P. and Ellfolk N. (1974). The primary structure of kidney bean leghaemoglobin. FEBS Lett. 43 239.
- Lightfoot D.A., Green N.K., Cullimore J.V. (1988). The chloroplast located glutamine synthetase of *Phaseolus vulgaris* L. nucleotide sequence expression in different organs, and uptake into isolated chloroplasts. Plant Molec. Biol. 11, 191-202.
- Magasanik B. (1988). Reversible phosphorylation of an enhancer binding protein regulating the transcription of bacterial nitrogen utilization genes. Trends in Biochem. Sci. 13, 475-479.
- Marks I and Sprent J.I. (1974). The localization of enzymes in fixed sections of soybean root nodules by electron microscopy. J. Cell Sci. 16 (3), 623-638.
- Martineau B. and Taylor W.C. (1986). Cell specific photosynthetic gene expression in maize determined using cell separation techniques and hybridization *in situ*. Plant Physiol. 82, 613-618.
- Meeks-Wagner D.R., Dennis E.S., VanTran Thanh K., Peacock W.J. (1989). Tobacco genes expressed during *in vitro* floral initiation and their expression during normal plant development. The Plant Cell 1, 25-35.
- Meyerowitz E.M. (1987). *In situ* hybridization to RNA in Plant Tissue. Plant Molec. Biol. Rep. 5 (1), 242-250.
- Mifflin B.J. and Cullimore J.V. (1984). Nitrogen Assimilation in the legume-*Rhizobium* symbiosis: a joint endeavor. In Genes involved in microbe-plant interactions (Verma D.P.S. and Hohn Th. eds.), Springer-Verlag, Vienna, p129-196.

Mifflin B.J., Lara M., Saarelainen R., Gebhardt C., Cullimore J.V. (1985). Physiology and molecular biology of plant glutamine synthetase. Proc. 15th FEBS. Congress, Part A; VNU Science Press, Moscow, pp431-439.

Moore P.J. and Staehelin L.A. (1988). Immuno-gold localization of the cell-wall-matrix polysaccharides rhamnogalacturonase I and xyloglucan during cell expansion and cytokinesis in *Trifolium pratense* L.; Implications for secretory pathways. *Planta* 174, 433-445.

Morrison-Baird L. and Wheeler B.D. (1982). Morphogenesis of effective and ineffective root nodules in *Phaseolus vulgaris* L. *Bot. Gaz.* 143 (1), 41-52.

Mosse B. (1964). Electron microscope studies of nodule development in some clover species. *J. Gen. Microbiol.* 36, 49-66.

Mouras A., Saul M.W., Essad S., Potyykus T. (1987). Localization by *in situ* hybridization of a low copy chimaeric resistance gene introduced into plants by direct gene transfer. *Molec. Gen. Genet.* 207, 204-209.

Mouras A., Negrutiu I., Hoth M., Jacobs M. (1989). From repetitive DNA sequences to single-copy gene mapping in plant chromosomes by *in situ* hybridization. *Plant Physiol. Biochem.* 27 (2), 161-168.

McClure P.R. and Israel D.W. (). Transport of nitrogen in the xylem of soybean plants. *Plant Physiol.* 64 (3) 411-416.

McCormack D.K., Farnden K.J.F., Boland M.J. (1982). Purification and properties of glutamine synthetase from the plant cytosol fraction of lupin nodules. *Arch. Biochem. Biophys.* 218, 561-571.

McCracken S. (1986). Preparation of RNA transcripts using SP6 RNA polymerase. *Focus (Bethesda Res. Labs.)* 7:2 5.

McFadden G.I., Bonig I., Cornish E.C., Clarke A.E. (1988). A simple fixation and embedding method for use in hybridization histochemistry on plant tissues. *Histochemical J.* 20, 575-586.

McInnes J.L., Dalton S., Vize P.D., Robins A.J. (1987). Non-radioactive photobiotin labelled probes detect single copy genes and low abundance mRNA. *Biotechnology* 5 269.

McNally S.F., Hirel B., Gadal P., Mann A.E., Stewart G.R. (1983). Glutamine synthetases of higher plants. *Plant Physiol.* 72, 22-25.

McParland R.H., Guevara J.G., Becker R.R., Evans H.J. (1975). The purification and properties of the glutamine synthetase from the cytosol of soybean root nodules. *Biochem. J.* 153, 597-606.

Nelson T. and Langdale J.A. (1989). Patterns of leaf development in *C₄* plants. *The Plant Cell.* 1, 3-13.

Newcomb W. (1976). A correlated light and electron microscopic study of symbiotic growth and differentiation in *Pisum sativum* root nodules. *Can. J. Bot.* 54, 2163-2186.

- Newcomb W. (1981). Nodule morphogenesis and differentiation. Int. Rev. of Cyt. Supp. 13, 247-298.
- Newcomb W. and Peterson R.L. (1979). The occurrence and ontogeny of transfer cells associated with lateral roots and root nodules in Leguminosae. Can. J. Bot. 57 (23), 2583-2616.
- Newcomb W., Sippell D., Peterson R.L. (1979). The early morphogenesis of *Glycine max* and *Pisum sativum* root nodules. Can. J. Bot. 57, 2603-2616.
- Newcomb W.E. and Tandon S.R. (1981). Uninfected cells of soybean root nodules: Ultrastructure suggests a key role in ureide production. Science 212, 1394-1396.
- Newton E.H., (1987). New man-made nitrogen-fixing systems. Phil. Trans. R. Soc. Lond. B. 317 (67), 259.
- Newton E.H. and Tandon S.R. (1981). Uninfected cells of soybean root nodules: ultrastructure suggests a key role in ureide metabolism. Science 212, 1394-1396.
- Noel D.K., Stacey G., Tandon S.R., Silver L.E., Brill W.J. (1982). *Rhizobium japonicum* mutants defective in symbiotic nitrogen fixation. J. Bacteriol. 152, 485-494.
- Norris J.H., Macol L.A., Hirsch A.M. (1988). Nodulin gene expression in effective alfalfa nodules and in nodules arrested at 3 different stages of development. Plant Physiol. 88, 321-328.
- Nutman P.S. Centenary lecture: a century of Nitrogen Fixation. Phil Trans Royal Soc. B. Biol. 317, 67-298.
- Ortega J.L., Campos F., Sanchez F., Lara M. (1986). Expression of 2 different glutamine synthetase polypeptides during root nodule development in *Phaseolus vulgaris* L. Plant Physiol. 80, 1051-1054.
- Padilla J.E., Campos F., Conde V., Lara M., Sanchez F. (1987). Nodule specific glutamine synthetase is expressed before the onset of nitrogen fixation in *Phaseolus vulgaris* L. Plant Molec. Biol. 9, 65-74.
- Pankhurst C.E., Craig A.S., Jones W.J. (1979). Effectiveness of *Lotus* root nodules. J. Exp. Bot. 30, 1084-1093.
- Parthasarathy M.V. (1987). *In situ* localization of actin filaments in higher plant cells using fluorescent probes. Plant Molec. Biol. Rep. 5 (1), 251-259.
- Pate J.S. (1973). Uptake, assimilation and transport of nitrogen compounds by plants. Soil Biol. Biochem. 5, 109-119.
- Pate J.S., Atkins C.A., White S.T., Rainbird R.M., Woo K.L. (1980). Nitrogen nutrition and xylem transport of nitrogen in ureide-producing grain legumes. Plant Physiol. 65, 961-965.
- Pate J.S., Gunning B.E.S., Briarty L.G. (1969). Ultrastructure and functioning of the transport system of the leguminous root nodule. Planta 85, 11-34.

Pate J.S. and Atkins C.A. (1983). Nitrogen uptake, transport and utilization. In: Nitrogen fixation, vol. 3 (legumes), ed. W.J. Broughton. pp245-298. Oxford: Clarendon Press.

Pelerman J., Boertan w., Engler g., Seurinck J., Botterman j., Alliotte T., Montagu M.V., Inze D. (1989). Strong cellular preference in the expression of a housekeeping gene of *Arabidopsis thaliana* encoding S-adenosylmethione synthetase. The Plant Cell 1, 81-93.

Perrot-Rechemann C., Joannes M., Squall D., Lebacq P. (1989). Detection of phosphoenolpyruvate and ribulose 1,5,-bisphosphate carboxylase transcripts in maize leaves by *in situ* hybridization with sulfonated cDNA probes. J. Histochem. and Cytochem. 37 (4), 423-428.

Peters K.N., Frost J.W., Long S.R. (1986). A plant flavone, luteolin, induces expression of *Rhizobium meliloti* nodulation genes. Science 223, 977-979.

Prasad D.N. (1973). Biology of root nodules of *Phaseolus* Spp. with reference to their anatomical structures. Proc. Indian Nat. Acad. Part B. Biol. Sci. 38 (1/2), 1-7.

Raikel N.V., Bednarek S.Y., Lerner D.R. (1989). *In situ* RNA hybridization in plant tissues. In: Plant Molecular Biology Manual. Gelvin S.B. and Schilperert R.A. eds. (Boston: Kluwer Academic Publishers). Book 9, pp1-32.

Robert F.M. and Wong P.P. (1986). Isoenzymes of glutamine synthetase in *Phaseolus vulgaris* L. and *Phaseolus lunatus* L. root nodules. Plant Physiol. 81, 142-148.

Robertson J.G., Warburton M.F., Farndon K.J.F. (1975a). Induction of glutamine synthetase during nodule development in lupin. FEBS Letters 55 (1), 33-37.

Robertson J.G., Farnden K.J.F., Warburton M.P., Banks J.A.M. (1975b). Induction of glutamine synthetase during nodule development in lupin. Aust. J. Plant Physiol. 2, 265-72.

Robertson J.G. and Farnden K.J.F. (1980). Ultrastructure and metabolism of the developing legume root nodule. In: The Biochemistry of Plants-A comprehensive treatise. Stumpf P.K., Comm E.E., vol.5. Mifflin P.J. ed. p65-113.

Robertson J.G., Wells B., Bisseling T., Farnden K.J.F., Johnston A.W.B. (1984). Immuno-gold localization of leghaemoglobin in cytoplasm in nitrogen-fixing root nodules of pea. Nature 311, 254-256.

Sanders R.E., Carlson R.W., Albersheim T. (1978). A *Rhizobium* mutant incapable of nodulation and normal polysaccharide secretion. Nature 271, 240-242.

Sasakawa H., Hyoshi T., Sugiyama J. (1988). Immuno-gold localization of nitrogenase in root nodules of *Eleagnus pungens thunb.* Plant Cell Physiol. 29 (7), 1147-1152.

- Scheres B., Horvath B., van de Wiel C., Zalensky A., Hirsch A., Bisseling T. (1989). Identification of *Rhizobium leguminosarum* genes involved in the induction of early nodulin gene expression. Abstract from the EMBO Symposium 1989, p7.
- Schmid J., Doerner P.W., Lamb C.J. (1989). The expression of two bean chalcone synthase genes in transgenic tobacco plants. Abstract from the EMBO symposium 1989, p187.
- Schmelzer E., Jahnen W., Hahlbrock K. (1988). *In situ* localization of light-induced chalcone synthase mRNA, chalcone synthase and flavonoid end products in epidermal cells of parsley leaves. Proc. Nat. Acad. Sci. U.S.A. 85, 2989-2993.
- Schubert K.R. (1986). Products of biological nitrogen fixation in higher plants: synthesis, transport and metabolism. Ann. Rev. Plant Physiol. 37, 539-574.
- Schubert K.R. and Evans H.J. (1976). Hydrogen evolution: a major factor affecting the efficiency of nitrogen fixation in nodulated symbionts. Proc. Nat. Acad. Sci. U.S.A. 73, 1207-1211.
- Sengupta-Gopalan C. and Pitas J.W. (1986). Use of nodule specific cDNA clones as molecular probes for the study of expression of nodulin genes during soybean nodule development. Plant Molec. Biol. 7, 189-199.
- Sengupta-Gopalan C., Pitas J.W., Thompson D.V., Hoffman L.M. (1986). Expression of host genes during root nodule development in soybeans. Mol. Gen. Genet. 203 (3), 410-420.
- Singer R.H., Bentley L.J., Willnave C. (1986). Optimization of *in situ* hybridization using isotopic and non-isotopic detection methods. Biotechniques 4 (3), 230.
- Smith J.D. (1949). The concentration and distribution of haemoglobin in the root nodules of leguminous plants. Biochem. J. 44, 585-591.
- Smith A.G., Hinchee M., Horsch R. (1987). Cell and tissue specific expression localized by *in situ* RNA hybridization in floral tissues. Plant Molec. Biol. Rep. 5, 237-241.
- Sprent J.I. (1984). Nitrogen Fixation. In: Advanced plant physiology, (Wilkins M.B. ed.) London Pitman Publishing Co. pp249-273.
- Sprent J.I. (1986). Benefits of *Rhizobium* to agriculture. TIBTECH, May 1986, 124.
- Streeter J.G. (1980). Carbohydrates in soybean nodules. Plant Physiol. 66, 471-476.
- Streeter J.G. (). Nitrate inhibition of legume nodule growth and activity. Plant Physiol. 77 (2), 321-324.
- Streeter J.G. and Salminen S.O. (1985). Carbon metabolism in legume nodules. In: Nitrogen fixation research progress, eds. Evans H.J., Bottomley P.J., Newton W.E., Dordrecht: Martinus Nijhoff. pp277-283.

- Stougaard J., Sandal N.N., Gron A., Kuhle A., Marcker K.A. (1987). 5' analysis of the soybean leghaemoglobin *lbc₂* gene: regulatory elements required for promoter activity and organ specificity. *EMBO. J.* 6 (12), 3565-3569.
- Sutherland J.M. and Sprent J.I. (1984). Calcium oxalate crystals and crystal cells in determinate root nodules of legumes. *Planta* 161 (3), 193-200.
- Syono K., Newcomb W., Torrey J.G. (1976). Cytokinin production in relation to the development of pea root nodules. *Can. J. Bot.* 54, 2155-2186.
- Syrjanen S., Partanen P., Mantyljarvi R., Syrjanen K. (1988). Sensitivity of *in situ* hybridization techniques using biotin and ³²S labelled human papillomavirus (HPV) DNA probes. *J. Virol. Methods* 19, 225-238.
- Tanaja K. and Singer R.H. (1987). Use of oligodeoxynucleotide probes for quantitative *in situ* hybridization to actin mRNA. *Analytical Biochem.* 166, 389-398.
- Tingey S.V. and Coruzzi G.M. (1987). Glutamine synthetase of *Nicotiana plumbaginifolia*. *Plant Physiol.* 84, 366-373.
- Tingey S.V., Walker E.L., Coruzzi G.M. (1987). Glutamine synthetase genes of pea encode distinct polypeptides which are differentially expressed in leaves roots and nodules. *EMBO. J.* 6 (1), 1-9.
- Tischer E., DasSarma S., Goodman H.M. (1986). Nucleotide sequence of an alfalfa glutamine synthetase gene. *Mol. Gen. Genet.* 203, 221-229.
- Vance C.R., Slade S., Maxwell C.A. (1983). Alfalfa root nodule carbon dioxide fixation I. Association with nitrogen fixation and incorporation into amino acids. *Plant Physiol.* 72, 469-473.
- VandenBosch K.A. (1986). Light and electron microscopic visualization of uricase by immunolabelling of sections of resin embedded soybean nodules. *Journal of Microscopy* 143, 187-197.
- VandenBosch K.A., Bradley D.J., Knox J.P., Perotto S., Butcher G.W., Brewin N.J. (1989). Common components of the infection thread matrix and the intercellular space identified by immunocytochemical analysis of pea nodules and uninfected roots. *EMBO. J.* 8 (2), 335-342.
- VandenBosch K.A., Newcomb E.W. (1986). Immuno-gold localization of nodule-specific uricase in developing soybean root nodules. *Planta* 167, 425-436.
- VandenBosch K.A. and Newcomb W.E. (1988). The occurrence of leghaemoglobin protein in the uninfected interstitial cells of soybean root nodules. *Planta* 175, 442-451.
- Van de Wiel C., Nap J-P., Lammeren A.V., Bisseling T. (1988). Histological evidence that a defence response of the host plant interferes with nodulin gene expression in *Vicia sativa* root nodules induced by an *Agrobacterium* transconjugant. *J. Plant Physiol.* 132, 446-452.

Vance C.P. (1983). *Rhizobium* infection and nodulation: a beneficial plant disease?. Ann. Rev. Microbiol. 37 399-424.

Vance C.P., Johnson L.E.B., Stade S., Groat R.G. (1982). Birdsfoot trefoil (*Lotus corniculatus*) root nodules: morphogenesis and the effect of forage harvest on structure and function. Can. J. Bot. 60, 505-518.

Verma D.P.S. and Bal A.K. (1976). Intracellular site of synthesis and localization of leghaemoglobin in root nodules. Proc. Nat. Acad. Sci. U.S.A. 73 (11), 3843-3847.

Verma D.P.S., Brisson N., Lara M., Ortega J.L., Valderrama B. (1987). Localization of the glutamine synthetase polypeptides in *Phaseolus* root nodules. In: Molecular genetics of plant-bacteria interactions. Martinus Nijhoff, Dordrecht pp142-144.

Verma D.P.S., Fortin M.G., Stanley J., Mauro V.P., Purohit S., Morrison N. (1986). Nodulins and nodulin genes of *Glycine max*. Plant Molec. Biol. 7, 51-61.

Verma D.P.S., Haugland R., Brisson N., Legocki R.P., Lacroix L. (1981). Regulation of the expression of leghaemoglobin genes in effective and ineffective root nodules of soybean. Biochimica et Biophysica Acta. 653, 98-107.

Verma D.P.S. and Long S. (1983). The molecular biology of *Rhizobium*-legume symbiosis. Int. Rev. of Cyt. Supp. 14, 211-245.

Vezina L-P., Hope H.J., Joy K.W. (1987). Isoenzymes of glutamine synthetase in roots of pea (*Pisum sativum* L. cv. Little Marvel), and alfalfa (*Medicago media* cv. Saramac). Plant Physiol. 83, 58-62.

Vezina L-P. and Langlois J.R. (1989). Tissue and cellular distribution of glutamine synthetase in roots of pea (*Pisum sativum*) seedlings. Plant Physiol. 90, 1129-1133.

Wahl G.M., Stern M., Stark G.R. (1979). Efficient transfer of large DNA fragments from agarose gels to diazobenzyloxymethyl-paper and rapid hybridization by using dextran sulphate. Proc. Nat. Acad. Sci. U.S.A. 76 (8), 3688-3697.

Werner D., Morschel E., Stripf R., Winchenbach B. (1980). Development of nodules of *Glycine max* infected with an ineffective strain of *Rhizobium japonicum*. Planta 147, 320-329.

Whittaker R.G., Lennox S., Appleby C.A. (1981). Relationship of the minor soybean leghaemoglobins d_1 , d_2 , d_3 and the major leghaemoglobins c_1 , c_2 and c_3 . Biochem. Int. 3, 117-124.

Wong S.L. and Verma D.P.S. (). Promoter analysis of soybean nuclear gene coding for nodulin-23, a nodule specific polypeptide involved in symbiosis with *Rhizobium*. EMBO. J. 4 (10), 2431-2438.

Yates M.G. (1980). Biochemistry of nitrogen fixation. In: The biochemistry of plants (ed. B.J. Mifflin), Vol. 5 Amino acids and derivatives. pp1-64. New York and London Academic Press.

