

## THE ATMOSPHERE OF THE SOIL: ITS COMPOSITION AND THE CAUSES OF VARIATION.

BY EDWARD JOHN RUSSELL AND ALFRED APPELYARD.

(*Rothamsted Experimental Station.*)

(With 17 Text-figures.)

### *Introduction.*

THE remarkable relationships existing between the microorganisms of the soil and the growth of plants have given rise to numerous researches on the bacteria, fungi, and more recently the protozoa of the soil, and considerable knowledge has now been obtained of the organisms present in normal soils. The earlier investigations were necessarily confined largely to methods of isolation, descriptions of the organisms found and studies of their behaviour in certain culture solutions, but sufficient of this preliminary work has been done to enable us to attack the real problem and try to obtain a picture of the life in the soil as it actually is. For this purpose it is necessary to know the relative abundance of the various organisms, to find out which are active and which inert, and to discover what the active forms are doing and what is their mode of life. Before the bacteriological and zoological work can be fully interpreted, however, it is necessary to discover the conditions under which life in the soil goes on, and in the series of papers, of which this is the first, it is proposed to deal with the air supply, water supply, and temperature of our own soils and by comparison with other investigations to see how far the observed relationships hold generally.

In the present paper we shall confine ourselves to the atmosphere of the soil. The soil mass is porous and the volume of solid matter in our case<sup>1</sup> is approximately two-thirds of the whole, leaving one-third pore space. The pore space, however, is not empty but contains a considerable amount of water, and the actual space empty except for

<sup>1</sup> For analysis of the soil, see p. 44.

air is commonly not more than 10 to 20 per cent. of the volume of the soil. The pores appear to be continuous and seem to maintain fairly complete communication between the various layers of the soil; in some places the communication is made more effective by the presence of cracks and burrows.

The soil atmosphere is the air present in these pores. Its biological significance lies in the fact that it is the air surrounding the soil organisms and the roots of plants, and is either in actual contact with them or is separated from them only by a thin film of water or colloidal matter. It is obviously part of the ordinary atmosphere but its composition is influenced by two causes: oxygen is absorbed and carbon dioxide produced by the inhabitants of the soil; while on the other hand, diffusion and other processes of gaseous interchange are constantly replacing it with ordinary atmospheric air, thus eliminating any differences in composition brought about by biochemical or other changes. As a net result the composition of the soil air at any moment is determined by the difference of velocity with which these two processes take place.

Unfortunately the mechanism of gaseous interchange in the soil is not sufficiently well known to enable us to ascertain the speed at which it goes on and so to discover the rate of production of carbon dioxide, a quantity of great importance in the study of the biochemical changes in the soil, but we have obtained evidence that our curves are mainly determined by the production and not by the loss of carbon dioxide from the soil. In any case for our present purpose of discovering the conditions under which life goes on in the soil it is mainly necessary to know the resultant of the various actions concerned.

Preliminary determinations showed that it is not difficult to draw a sample of gas from the soil, that is fairly representative of the soil air and is uncontaminated by atmospheric air. In our experiments the depth selected has been 6 inches, this being right in the region where the soil changes take place, besides being convenient for working. But as a matter of fact no great difference in composition was found on going somewhat deeper: thus the following results (Table I) were obtained at 6 and 18 inches respectively.

In general the soil air was found to be very similar in composition to ordinary atmospheric air, especially as regards the percentages of oxygen and of nitrogen. It commonly contains less oxygen and more carbon dioxide, usually also more nitrogen, but the differences are often small and only detected with certainty by careful analyses (Table VI).

TABLE I. *Comparison of composition of soil air taken from a depth of 6 and 18 in. in the soil. 30 January 1914. Percentage by volume.*

	CO <sub>2</sub>		O <sub>2</sub>	
	6" deep	18" deep	6" deep	18" deep
Grassland, Greatfield .. .. .	1.46	1.64	18.44	17.87
Arable land, Broadbalk (dunged plot) ..	0.34	0.50	20.52	20.33
Arable land, Broadbalk (unmanured plot)	0.34	0.45	20.32	20.35

Unlike atmospheric air, however, the soil air is not constant in composition but changes somewhat from day to day and even on the same day at different spots in the field; nevertheless the values fall within fairly narrow limits.

There are two kinds of variation in composition; the local daily ones just referred to, and the greater variations produced by season, treatment, etc.: the latter may be so great as to mask altogether the local fluctuations. In our experiments the greatest factor of all was the effect of season. Whatever the history of the soil its atmosphere in spring and to a less extent in autumn was characterised by high amounts of carbon dioxide indicating rapid biochemical changes at these seasons of the year, while in summer and winter the amounts were much lower. The effect is complex and includes at least two others each of which was found to be very potent: the temperature during the period December to June, and moistness of the soil during part of the summer months. (Figs. 7 and 8.)

In addition there is the possibility that a certain amount of partial sterilisation has taken place during the winter and during the dry summer, leading to considerable bacterial activity immediately conditions become favourable once more.

This seasonal effect dominates all the others and impresses on all the curves the same general type seen in Figs. 1-6<sup>1</sup>. Other factors, such as manuring, cropping, etc., simply raise or lower the whole curve according as they give rise to more or less carbon dioxide; in particular the effect of the crop proved to be considerably less than was anticipated.

Within these major variations there fall the smaller fluctuations

<sup>1</sup> See Table VI for data.

attributable to differences in composition of the soil<sup>1</sup>, especially the distribution of organic matter, organisms, plant roots and passages such as cracks, burrows of earthworms, etc.; to daily changes in temperature and moisture content of the soil, or to any cause that would facilitate interchange between the soil air and the atmosphere. These local and daily fluctuations lie between relatively narrow limits, and by taking a mean of a number of samples it is not difficult to arrive at a value that approximately expresses the composition of the soil air at the time. Some of these values are given in Table II.

TABLE II. *Mean composition of soil air from various Rothamsted plots. Percentage by volume.*

	CO <sub>2</sub>	O <sub>2</sub>	N <sub>2</sub>
Arable land manured (farmyard manure) and cropped			
Broadbalk wheat (Summer .. ..)	0.23	20.74	79.03
Plot 2 (Winter .. ..)	0.37	20.31	79.32
Arable land unmanured and cropped			
Broadbalk wheat (Summer .. ..)	0.19	20.82	78.99
Plot 3 (Winter .. ..)	0.21	20.42	79.37
Arable land unmanured and cropped Hoos wheat			
Summer .. .. . . . . .	0.28	20.65	79.07
Winter .. .. . . . . .	0.20	20.71	79.09
Arable land unmanured and cropped Hoos fallow			
Summer .. .. . . . . .	0.12	20.84	79.04
Winter .. .. . . . . .	0.08	20.78	79.14
Mean of all the arable soils .. .. . . .	0.25±0.1	20.6±0.2	79.2±0.2
Pasture land. Winter .. .. . . . . .	1.57	18.02	80.04
Atmospheric air .. .. . . . . .	0.03	20.97	79.00

The column labelled nitrogen is simply the residual gas after the carbon dioxide and oxygen have been removed in the analytical process and it includes other gases just as in the case of atmospheric air. Sir James Dewar kindly examined some of the samples for hydrogen, but found only quantities of the same order as in the atmosphere, while our own tests have failed to reveal appreciable quantities either of

<sup>1</sup> We are here using the word to denote the whole of the surface soil complex: solid matter, water, air spaces, etc. It is unfortunate that no soil chemist has yet had the courage to coin a word to express this meaning. The word "soil" is ambiguous, as it means also the actual solid matter.

methane or any other combustible gas. We may therefore safely assume that the residual gas is practically all nitrogen.

This then represents the ordinary composition of the air filling the pores of the soil at a depth of 6 inches, the layer within which most of the important soil changes go on. As already pointed out it is very similar to ordinary atmospheric air but there are three important differences which may have much greater effects than would at first be expected:

1. The amount of carbon dioxide though low in the absolute, is nevertheless about ten or more times as high as in atmospheric air.
2. The amount of moisture present in the soil air is greater than in atmospheric air and is usually nearer the saturation point.
3. The soil air is still, there being much less opportunity for actual movement than in the atmosphere.

It is outside our present subject to discuss the effects of these characteristics and we need only indicate a few ways in which they may be expected to act.

There is considerable evidence that microorganisms are very sensitive to the medium in which they are placed, and the relatively high proportion of carbon dioxide in the soil atmosphere is likely to affect their activity. It is therefore necessary to take this factor into account before applying to the soil any deductions from bacteriological investigations made in the laboratory under ordinary atmospheric conditions.

In consequence of its stillness and its intimate contact with the moist soil particles, the soil air is likely to be saturated or nearly saturated with water vapour, and this condition is known to be favourable for organisms and to reduce the need for free liquid water.

The effect of the extreme stillness of the air, however, cannot be gauged; physiologists recognise that movement in the air is necessary for the comfort and well being of humans, and we should no doubt find the soil atmosphere intolerable from this cause alone, but it is difficult to form any estimate of its effect on microorganisms.

But this free air filling the pore spaces is not the only air in the soil. During the course of other experiments we had occasion to evacuate flasks containing soil, and we found that the vacuum persistently began to fall soon after exhaustion appeared to be complete. Gas was being evolved from the soil, but it came out only very slowly even when a good mercury pump was kept at work for several days.

The total amount of gas given up is not great; its characteristic feature is the absence of oxygen (except in small quantities) and the high proportion of carbon dioxide.

Some of the samples obtained had the composition shown in Table III.

TABLE III. *Composition of gas held absorbed by soil.*  
*Percentage by volume.*

	Weight of soil used, grms	Per-centage of Moisture	Approximate volume of gas removed in successive extractions	Percentage com-position of gas		
				CO <sub>2</sub>	O <sub>2</sub>	N <sub>2</sub>
Pasture soil	352	28	1st 30 c.c.	52.0	0.7	47.3
			2nd 30	84.8	0.2	15.0
			3rd 22	99.1	0.2	0.7
Soil covered with vegetation (Broadbalk wilderness)	400	22	1st 30 c.c.	19.3	5.5	75.2
			2nd 30	57.0	2.6	40.4
			3rd 15	98.7	0.2	1.1
Rich garden soil .. ..	468	20	1st 30 c.c.	89.5	0.2	10.3
			2nd 30	99.3	0.0	0.7
			3rd 15	94.4	0.0	0.6
			4th 30	96.8	0.0	3.1
			5th 30	92.3	0.0	7.6
Arable soil Broadbalk dunged plot ..	—	24	1st 30 c.c.	10.8	4.4	84.8
			2nd 30	57.9	1.8	40.3
			3rd 15	98.4	0.0	1.6
Broadbalk unmanured ..	497	16	1st 30 c.c.	6.3	15.1	78.6
			2nd 25	40.2	9.7	50.1

It will be observed that the composition varies with the pressure, and that the first samples withdrawn contain more oxygen than the last: the final samples are almost pure carbon dioxide.

The volume of gas obtainable depends on the amount of moisture in the soil as it is brought in from the field, and decreased as the soil becomes dryer; from which we may infer that the gas is partly dissolved in the soil moisture, though part may be dissolved in other soil constituents.

Thus it appears that there are two atmospheres in the soil: one present as free gas filling the pores, and practically as rich in oxygen as ordinary air, the other dissolved in the surface films of water and other substances, almost devoid of oxygen and consisting mainly of carbon dioxide with some nitrogen.

It is hardly likely on physical grounds that these atmospheres are abruptly parted at the surface of the film; it is more probable that the free air changes in composition at the surface of the particles where a thin layer of it is to some degree in equilibrium with the dissolved air. The stillness of the soil air is favourable to the formation of a stratum different in composition from the bulk and merging insensibly into it.

The very small amount of oxygen in the dissolved gas is evidence that the rate of consumption of oxygen in the solution is greater than the rate at which fresh supplies come in from the soil air, a fact of great biochemical significance. But still more important for our present purpose is the fact of the existence of this atmosphere almost devoid of oxygen.

We are accustomed to think of a drained cultivated soil as being under essentially aerobic conditions, and the analyses of the free air show that this view is correct. But the existence of this second atmosphere enables an organism that wants anaerobic conditions to find them by submerging itself into the medium in which this atmosphere is dissolved, especially if at the same time it associates itself with an aerobic form capable of taking up any oxygen that becomes dissolved. Thus alongside of the aerobic life in the soil there is the possibility of anaerobic life, and we can no longer dismiss a possible soil change as unlikely simply on the grounds that it requires anaerobic conditions. In the present paper we confine ourselves to the free air in the soil but hope to deal with the dissolved air later on.

#### *The free air in the soil.*

For the first examination of the free air of the soil we have to turn, as in many other agricultural studies, to the papers of Boussingault. In 1853 he published<sup>1</sup> the results of analyses of 36 samples of soil gas taken at a depth of 30–40 cms. At that time Bunsen's classical memoir had not been published nor had gas analysis methods been worked out, so that he was compelled to fix a pipe in the soil (thus causing considerable disturbance) and periodically to aspirate a large volume (2½ to 10 litres) of soil air through baryta water and weigh the carbonate formed. The method must have been cumbersome to work; nevertheless the results are fairly close to ours, the air obtained from soils

<sup>1</sup> Boussingault and Lévy, 'Mémoire sur la composition de l'air confiné dans la terre végétale,' *Annales de Chimie et de Physique*, 1853, 37, 5–50.

that had not recently been manured having the following mean composition:

Carbon dioxide	0.9	per cent.	by volume
Oxygen	19.6	„	„
Nitrogen	79.5	„	„

It is clear that the method gives rather high results for carbon dioxide because atmospheric air was found to contain 0.04 per cent. instead of 0.03 per cent. The air from a recently manured soil contained much more carbon dioxide—up to 10 per cent.—while the oxygen fell as low as .10 per cent.<sup>1</sup>: but as these are the only two out of the 36 they have been omitted from the general mean.

Boussingault and Léwy did not continue their analyses over any prolonged period, nor did they study the effect of conditions such as temperature, moisture content, etc., on the composition of the soil atmosphere. These problems were investigated in Germany and the work was the outcome of the discovery by Pettenkofer<sup>2</sup> of a simple and rapid method of estimating carbon dioxide which he successfully applied in determining the amount of carbon dioxide in the air of the Munich soils<sup>3</sup>. This new method was much more rapid than the older one of Boussingault, enabling many determinations to be made and not requiring great skill in manipulation. Hence a number of workers took it up and a succession of papers on the subject appeared in Wollny's Journal<sup>4</sup> also published from Munich.

It is unnecessary to review all the papers in detail: especially as this has already been done by Fodor<sup>5</sup>, Wollny<sup>6</sup>, and Letts and Blake<sup>7</sup>. Moreover, later work has shown that the results are about 30 per cent. too high<sup>8</sup>. For comparative purposes, however, the method serves

<sup>1</sup> We cannot help thinking there must have been some mistake here; in our experience the oxygen falls very low only in waterlogged soils (p. 32).

<sup>2</sup> Letts and Blake (*Proc. Roy. Soc. Dublin*, 1900, 9, 116) have shown that the principle of the method had already been used by Dalton and his pupils, but this work seems to have been unknown to Pettenkofer.

<sup>3</sup> M. von Pettenkofer, 'Ueber den Kohlensäuregehalt der Grundluft im Geröllboden von München in verschiedenen Tiefen und zu verschiedenen Zeiten,' *Zeitsch. f. Biologie*, 1871, 7, 395-417; and 1873, 9, 250-257.

<sup>4</sup> *Forschungen auf dem Gebiete der Agrikultur-Physik*, 1878-1898.

<sup>5</sup> J. Fodor, *Hygienische Untersuchungen über Luft, Boden und Wasser*, Braunschweig, 1881.

<sup>6</sup> E. Wollny, *Die Zersetzung der organischen Stoffe*, 1897.

<sup>7</sup> E. A. Letts and R. F. Blake, 'The carbonic anhydride of the atmosphere,' *Proc. Roy. Soc. Dublin* 1900, 9, 107-270, especially pp. 214 *et seq.*

<sup>8</sup> Caldwell, in Letts and Blake's paper, *Proc. Roy. Soc. Dublin* 1900, 9, 219-229.



sufficiently well. Successive workers showed that the amount of carbon dioxide in the soil air increased with the amount of organic matter, the water content, and the temperature of the soil. On one point, however, there was considerable disagreement which has survived to our own day: the effect of a growing crop on the production of carbon dioxide in the soil. F. Ebermayer<sup>1</sup> found less carbon dioxide in the soil of a wood than in a fallow soil. Möller<sup>2</sup> in one experiment found more carbon dioxide when a crop of grass was growing, in another less, but the conditions were not strictly comparable. In a better experiment Wollny<sup>3</sup> found that the effect depended on the season: in summer the cropped land (grass) was poorer in carbon dioxide than the fallow land while in winter it was richer. Of the various papers published during this early period this one by Wollny is of rather special interest because it contains numerous CO<sub>2</sub> values obtained between May and September which show an early summer minimum and late summer (end of August) maximum just like ours do. Numerous determinations were also made by Fodor at depths of 1, 2 and 4 metres below the surface of the soil and these showed a maximum percentage of CO<sub>2</sub> in July and a minimum in January or March<sup>4</sup>. No spring maximum was observed.

The earlier workers ascribed the formation of carbon dioxide to the decomposition of the organic matter and generally assumed that the process was the purely chemical "eremacausis" pictured by Liebig. But it was gradually recognised that soil contained numbers of microorganisms and in 1880 Wollny<sup>5</sup> adopting the method of Schloesing and

<sup>1</sup> Ebermayer, 'Mitteilungen über den Kohlensäuregehalt der Waldluft und des Waldbodens im Vergleich zu einer nicht bewaldeten Fläche,' *Forsch. auf dem Gebiete der Agrik.-Physik*, 1878, 1, 158-161.

<sup>2</sup> Joseph Möller, 'Ueber die freie Kohlensäure im Boden,' *ibid.* 1879, 2, 329-338.

<sup>3</sup> E. Wollny, 'Untersuchungen über den Einfluss der Pflanzendecke und der Beschattung auf dem Kohlensäuregehalt der Bodenluft,' *ibid.* 1880, 3, 1-15.

<sup>4</sup> Fodor, *loc. cit.* pp. 125 *et seq.*

<sup>5</sup> 'Untersuchungen über den Kohlensäuregehalt der Bodenluft,' *Landw. Versuchs. Stat.* 1880, 25, 373-391.

An earlier reference to the possible significance of microorganisms in producing the carbon dioxide of the soil occurs in a paper by Joseph Möller, 'Ueber die freie Kohlensäure im Boden' (*Mitt. aus dem forstlichen Versuchswesen Oesterreichs*, 1878, Heft. 2, 121-148). After showing that the amount of carbon dioxide is increased by additions of organic matter he goes on to state that the lower organisms and organic residues brought in from the air are of considerable importance in this connection.

We have been unable to see the original paper, but in the long abstract in Wollny's *Forschungen* no reference is made to any experiments and it does not appear that this was more than an expression of opinion. At any rate it made no impression and it is not referred to by other writers, nor even by Möller himself in his second paper already quoted.

Müntz demonstrated that these were the active agents, the proof being that, in presence of chloroform, soil produces only a fraction of the amount of carbon dioxide formed in untreated soil. This was confirmed by Déherain and Demoussy<sup>1</sup>. From that time it has been generally recognised that the carbon dioxide is mainly produced by the organisms of the soil.

The application of the Pettenkofer method had thus carried the problem a long way, and had given considerable information about the origin and fluctuations of the carbon dioxide in the soil air, but it gave no information at all about the oxygen, and the idea gradually became fixed that the soil atmosphere was deficient in oxygen, a view that was strengthened by the well-known benefits of "aerating" the soil.

Boussingault and Léwy had indeed shown that the percentage of oxygen in the soil air was almost the same as that in the atmosphere, but their results were overlooked. As a matter of fact they rather contributed to the growth of the idea, for in their paper they laid chief stress on the fact that soil air contained 22 times as much carbon dioxide as ordinary air, and did not emphasise its close similarity in oxygen content.

With the introduction of improved methods of gas analysis it became possible to obtain still further refinements in the study of the soil atmosphere. Schloesing *filis*<sup>2</sup> was one of the first to apply the new methods and although his investigation was not very extensive it sufficed to demonstrate the incorrectness of the current conception that the soil air was necessarily deficient in oxygen.

In 1880 Hempel published his book describing a fairly accurate form of gas analysis apparatus which is as easy to use as Pettenkofer's and readily allows of the examination of large numbers of samples of air taken from the soil. It was adopted by Erich Lau in a series of analyses of the air from the soil at Rostock<sup>3</sup>, one sample a month being taken from a sand, a loam, and a peat soil. The general result is that the soil air closely resembles ordinary air in its oxygen content, but that it contains about six times as much carbon dioxide; the actual mean values obtained at a depth of 15 cm. were, in percentages by volume:

<sup>1</sup> *Ann. Agron.* 22, 305.

<sup>2</sup> Th. Schloesing *filis*, 'Sur l'atmosphère confinée dans le sol,' *Compt. Rend.* 1889, 109, 618-20, 673-76.

<sup>3</sup> Erich Lau, *Beiträge zur Kenntnis der Zusammensetzung der im Ackerboden befindlichen Luft*, Inaug. Dissertation, Rostock, 1906.

	Sand	Loam	Peat	Sandy soil, dunged	
				Cropped with potatoes	Fallow
Carbon dioxide ..	0.11	0.14	0.43	0.57	0.18
Oxygen .. ..	20.79	20.69	20.35	20.22	20.73
Nitrogen .. ..	79.10	79.17	79.22	79.21	79.29

The minimum amounts of carbon dioxide (0.04, 0.05 and 0.12 per cent. in the sand, loam, and peat respectively) were found in February, the maximum (0.18, 0.31, and 0.81 per cent.) in July and August: no spring maximum was observed, but this might easily have been missed in the five weeks that elapsed between the taking of the May and the June samples. Some of the plots were planted and some not: the former contained more carbon dioxide than the latter, even in the summer; a result directly opposite to that obtained by Wollny.

Jodidi and Wells adopted Orsat's simpler form of the apparatus, and made a great number of analyses of the soil air from certain plots at Ames, Iowa, over the period April to August, 1910. The mean of all the results showed that at a depth of 7 inches the percentage of oxygen is 20.51, of carbon dioxide 0.25, and of nitrogen 79.24.

These various results are set out in Table IV and taken in conjunction with our own (Table VI) they establish beyond any reasonable doubt the close similarity between the soil air and the atmospheric air so far as oxygen and nitrogen content are concerned.

TABLE IV. *Mean composition of soil air.*

Percentage by volume of:			Locality	Investigators	Date
Oxygen	Nitrogen	Carbon dioxide			
20.6±0.2	79.2±0.2	0.2±0.1	Rostock, Germany	Erich Lau	1906
20.4±0.2	79.4±0.2	0.2±0.2	Ames, Iowa	Jodidi and Wells	1911
20.6±0.2	79.2±0.2	0.25±0.1	Rothamsted	Appleyard and Russell	1913-14

These figures are the means of the averages of the various plots.

*The significance of the fluctuations in composition in the soil air.*

As already stated the composition of the soil air at any moment is a resultant effect, being the difference between the rate at which the carbon dioxide is produced in the soil and that at which it is lost. At first sight it might appear that the composition must therefore be largely accidental but we have been able to show that it is not, and that the great fluctuations as distinct from the minor ones (p. 33) are regulated mainly by the rate of production of carbon dioxide in the soil. The method consists in finding some other substance in the soil which is *produced* in the same manner as the  $\text{CO}_2$ , but *lost* in a different way. If the curve showing the fluctuations of this substance is like the curve for  $\text{CO}_2$  it follows that the fluctuations are largely governed by the rate of production and therefore that the curves given in Figs. 1-5 are essentially production curves. If on the other hand the fluctuations do not resemble those of  $\text{CO}_2$  it follows that the curves are not essentially production curves but that their shape is due to a fortuitous balance of losses and gains.

The required substance is found in the nitrates of the soil which, like the carbon dioxide, are produced in the decomposition of the soil organic matter by bacteria but which are lost in a wholly different manner. Carbon dioxide is lost by gaseous diffusion, a process which proceeds most rapidly in dry conditions when the pores of the soil are most widely open: and least rapidly in wet conditions when the pores are more or less closed. The nitrates, on the other hand, suffer least loss under dry conditions and most loss in wet weather.

Determinations were therefore made of the amount of nitrate present in each plot on every occasion when samples of gas were drawn for analysis, and the values are plotted in the curves: unfortunately the necessity for this was not seen when the investigation first began so that no values were obtained during the first four months.

Inspection of the curves shows that they are all of the same type: there is some displacement in point of time but no difference in character. It follows then that the character of the fluctuations of  $\text{CO}_2$  content in the soil air is determined by the rate of biochemical change in the soil. Further proof is afforded by the fact that the curves for bacterial numbers also show a close resemblance to those of  $\text{CO}_2$  in the soil air.

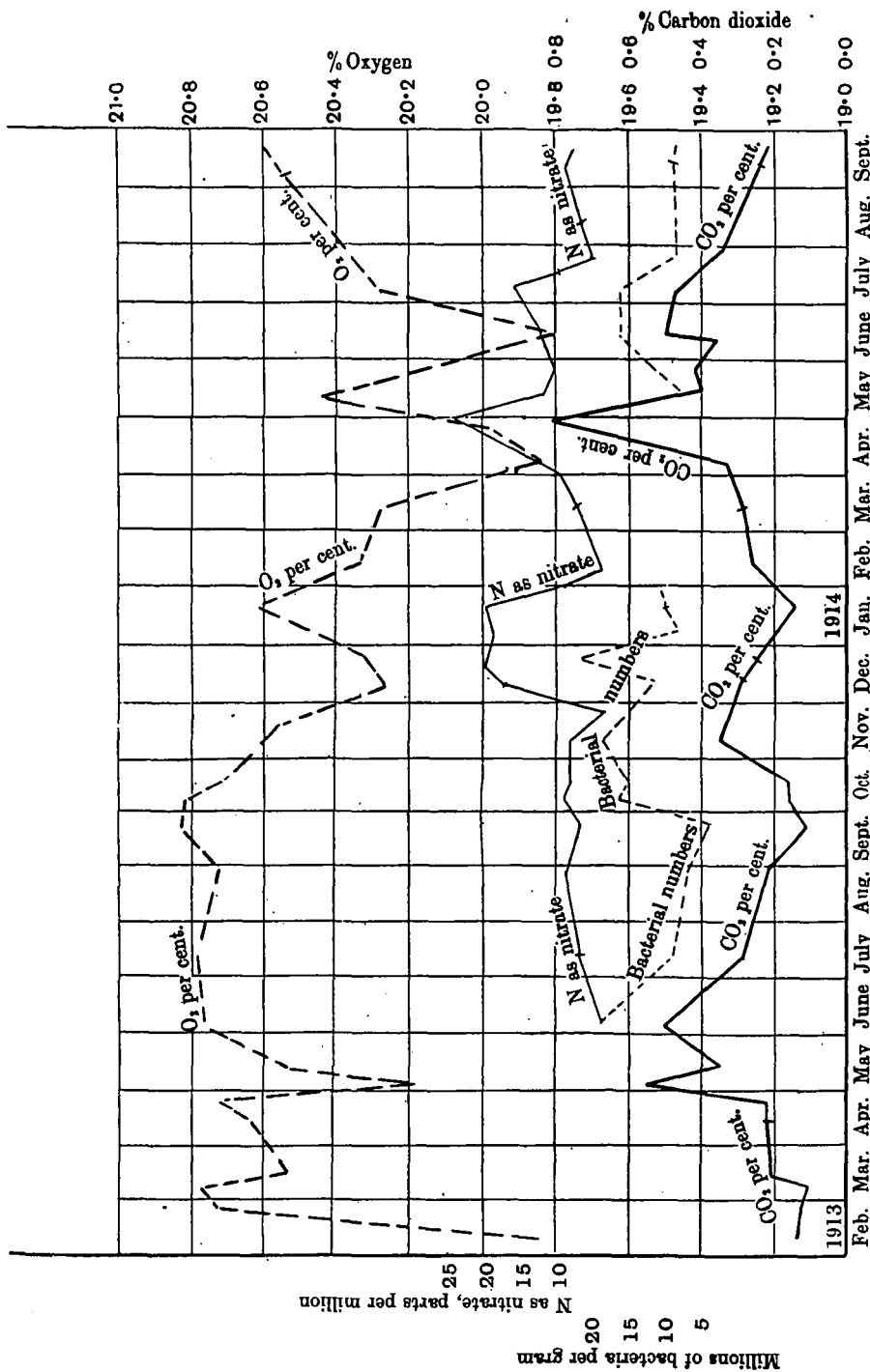

Fig. 1. Curves showing percentage of CO<sub>2</sub> and O<sub>2</sub> in soil air, and bacterial numbers (millions per gram) and nitrate (parts per million) in Broadbalk unmanured plot.

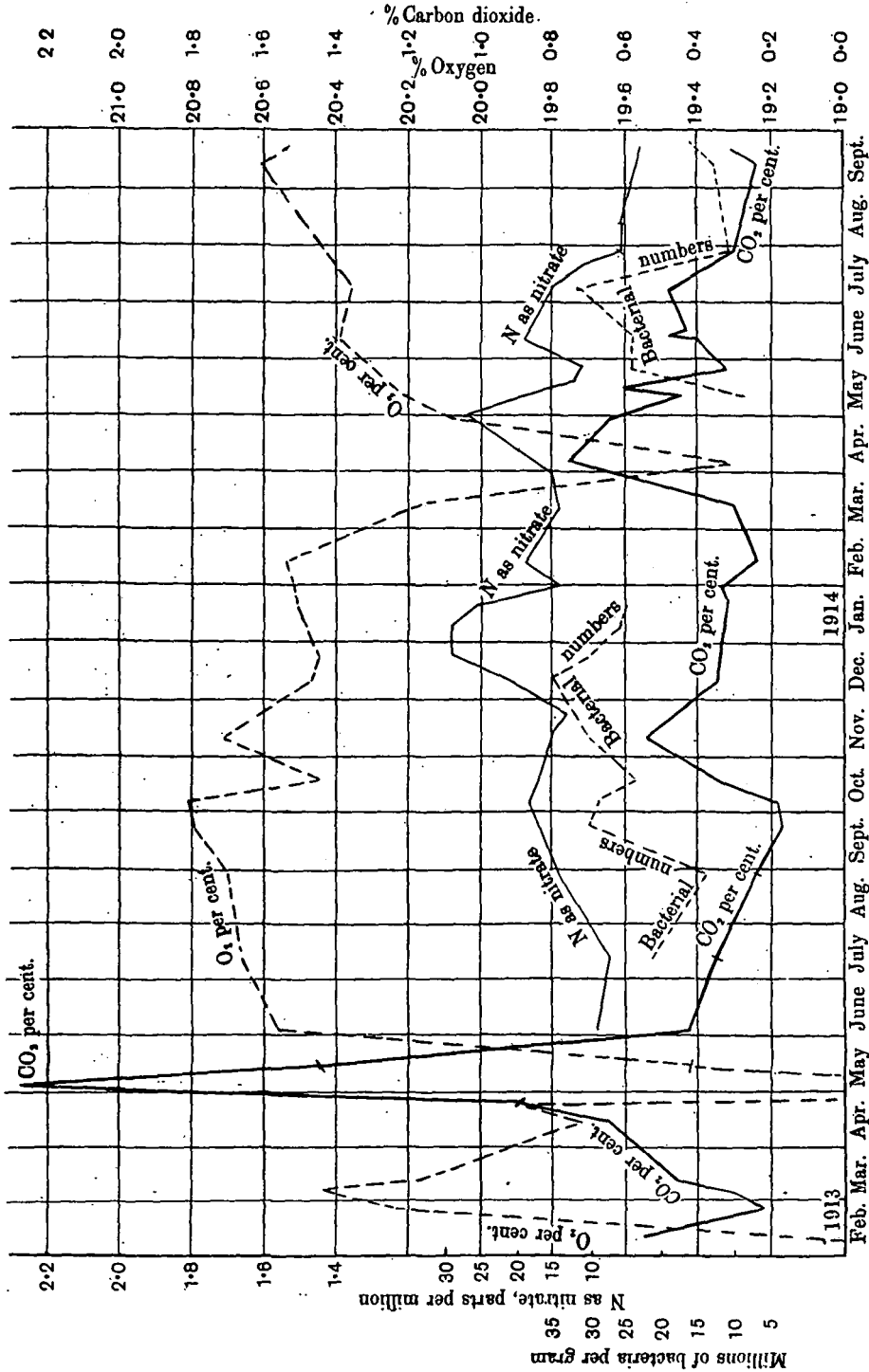

Fig. 2. Curves showing percentage of CO<sub>2</sub>, and of O<sub>2</sub> in soil air, and bacterial numbers (millions per gram) and nitrate (parts per million) in Broadbalk dunged plot.

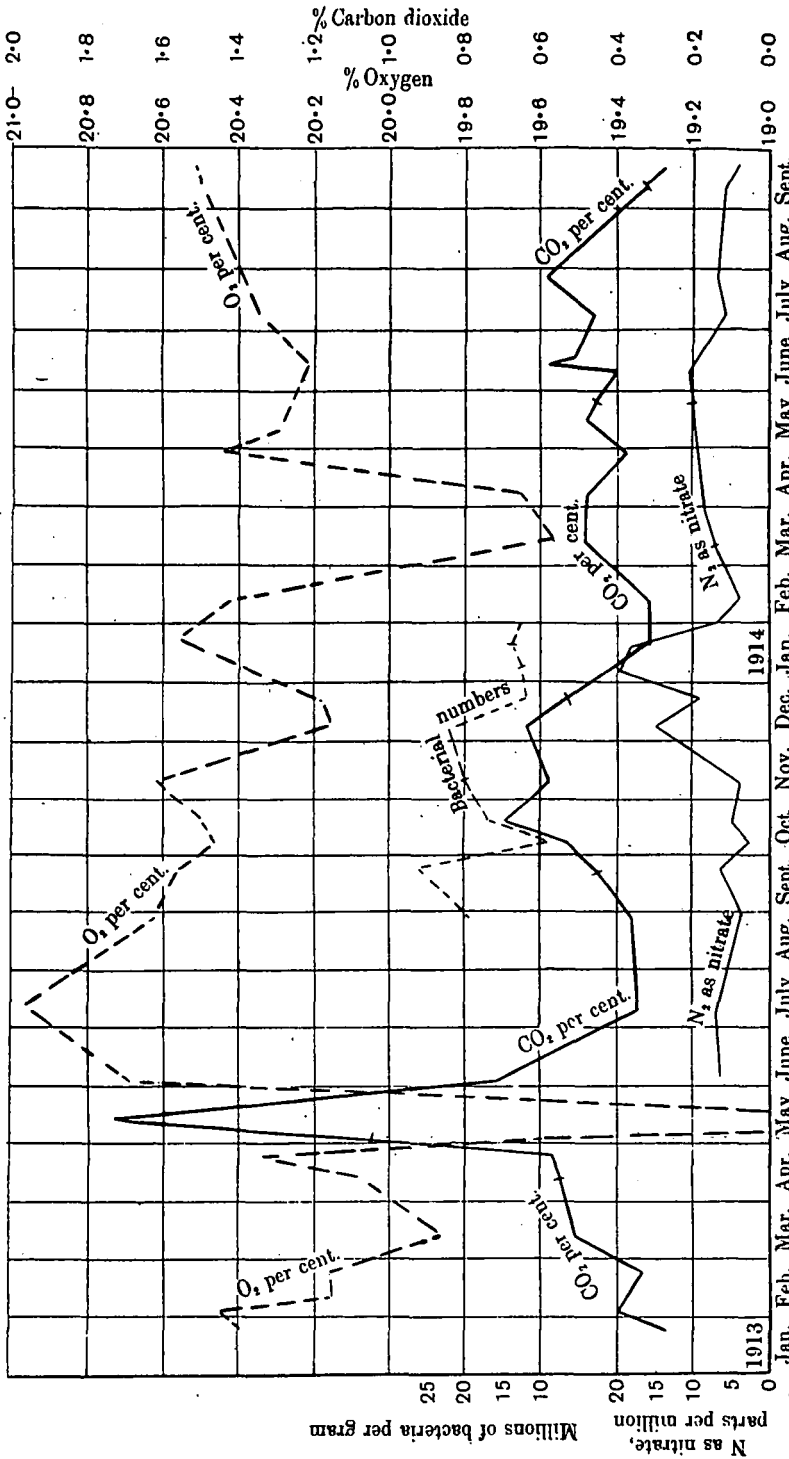

Fig. 3. Curves showing percentages of CO<sub>2</sub> and of O<sub>2</sub> in soil air, and bacterial numbers (millions per gram) and nitrate (parts per million) in Broadbalk wilderness.

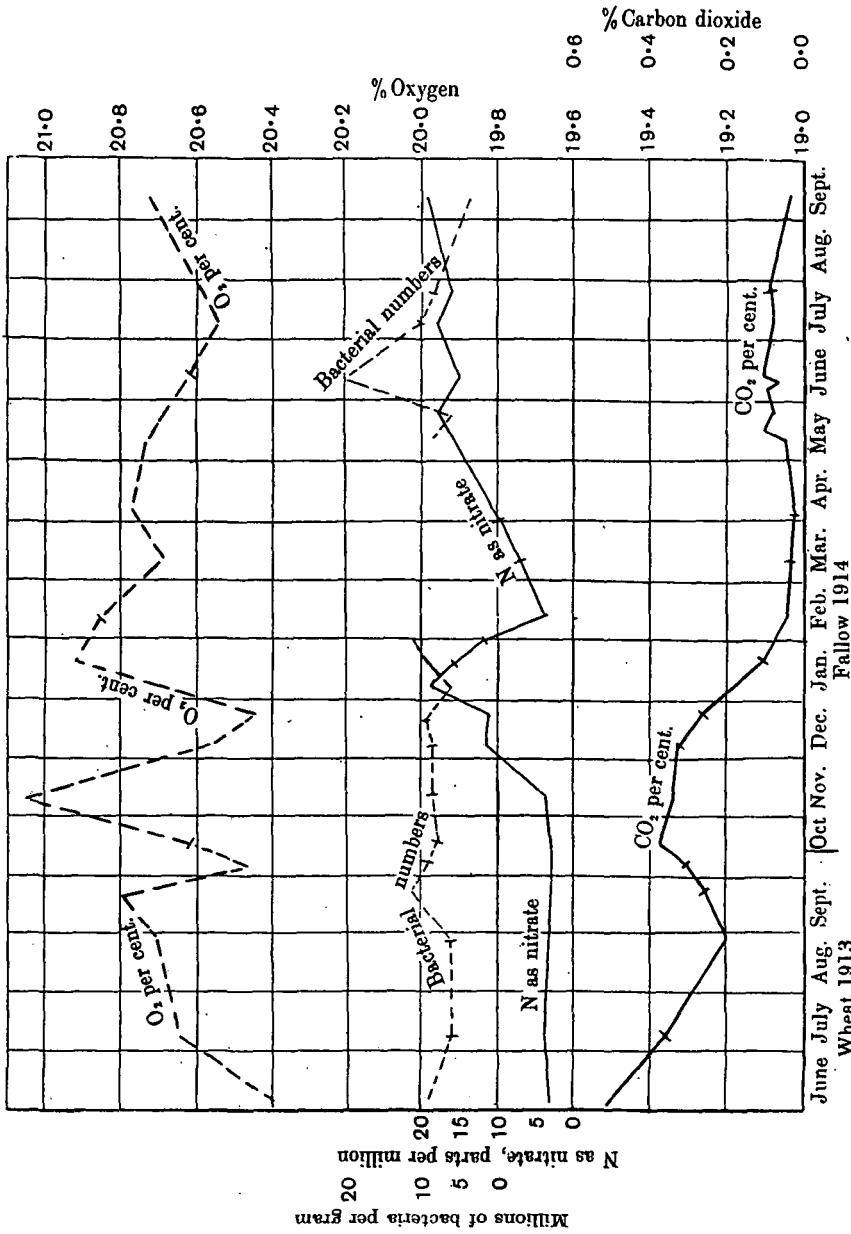

Fig. 4. Curves showing percentages of CO<sub>2</sub> and O<sub>2</sub> in soil air of Hoos wheat and fallow plots. (a) Cropped till Sept. 1913, Fallow during season 1913-14.



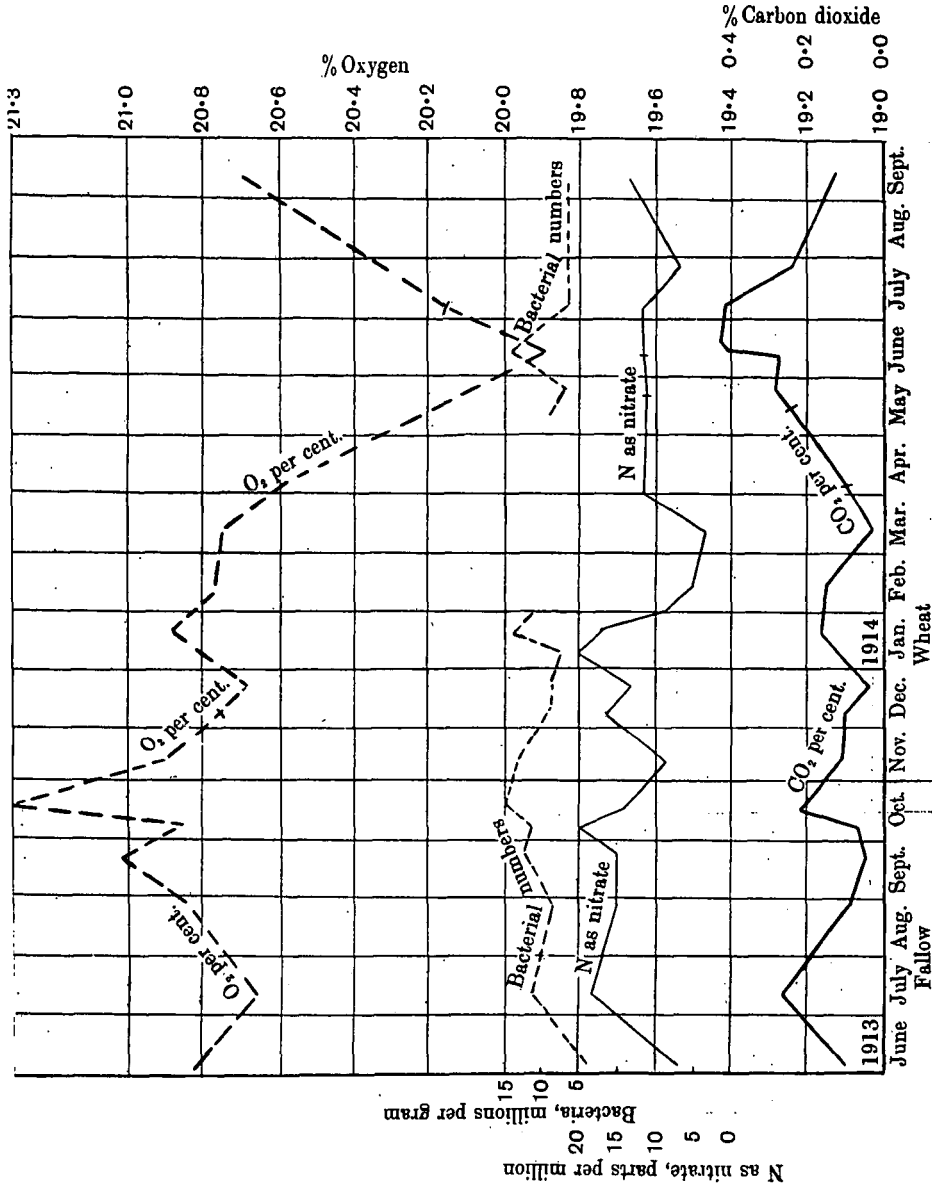

Fig. 5. Curves showing percentages of CO<sub>2</sub> and of O<sub>2</sub> in soil air of Hoos wheat and fallow plots. (b) Fallow till Oct. 1913, cropped during season 1913-14.

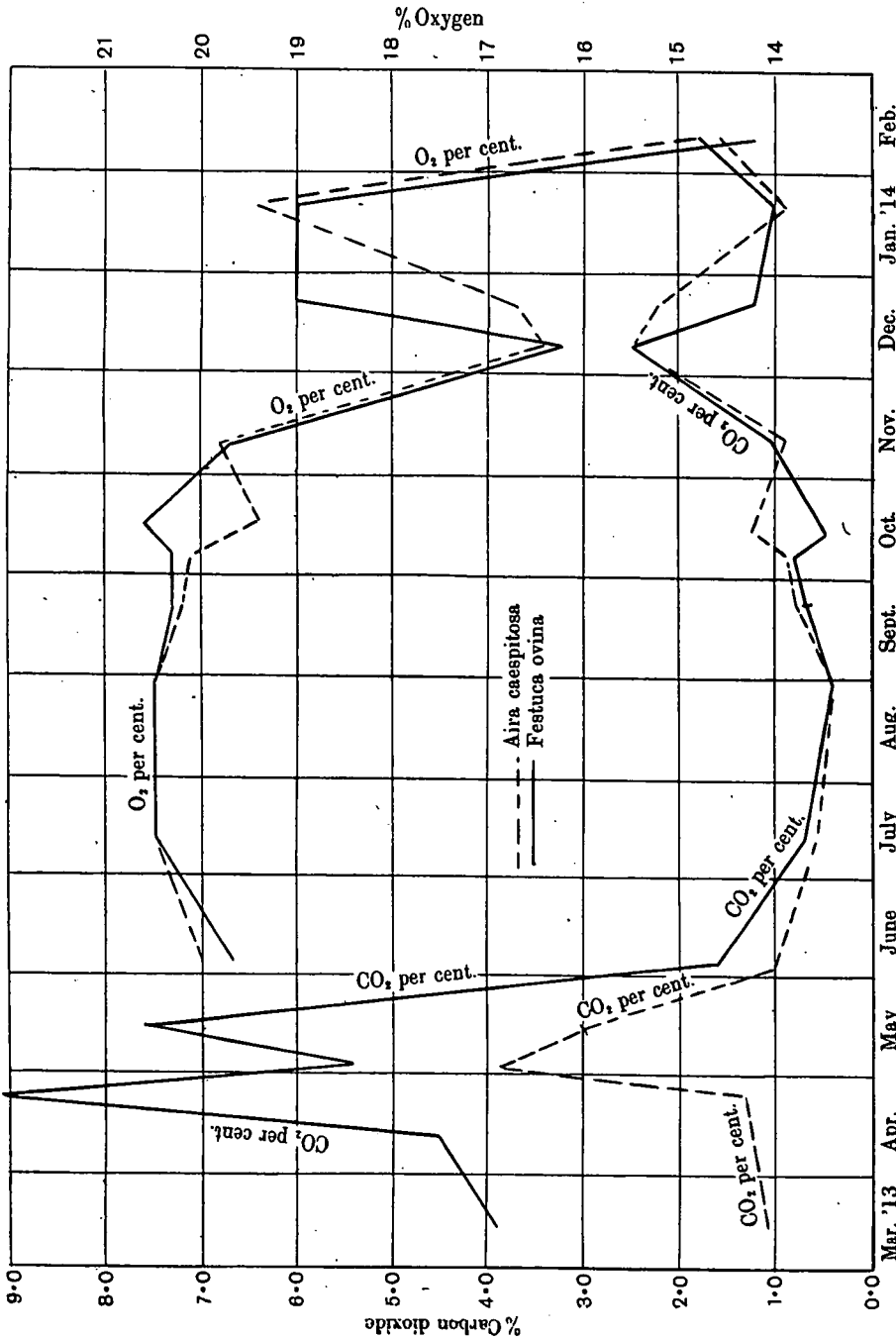

Fig. 6. Curves showing percentages of CO<sub>2</sub> and of O<sub>2</sub> in soil air from Geescroft field under patches of *Aira caespitosa* and of *Festuca ovina* respectively.

*The relationship of CO<sub>2</sub> to oxygen.*

The oxygen curves are generally reciprocal to the CO<sub>2</sub> curves, *i.e.* the oxygen falls as the CO<sub>2</sub> rises, and the agreement is sufficiently close to justify the assumption that the oxygen is mainly used up in producing CO<sub>2</sub>. But the agreement is not absolute and the discrepancies are considerably beyond the limits of experimental error.

TABLE V. *Relationship of CO<sub>2</sub> to oxygen at times of rapid nitrification.*

Plot	Period	CO <sub>2</sub> in soil air %	O <sub>2</sub> in soil air %	Sum	Fall in O <sub>2</sub> in excess of rise in CO <sub>2</sub>	Increase in nitrate during period, parts of N per million
Broadbalk duned	Nov. 1913	0.54	20.72	21.26		
	Dec. "	0.35	20.47	20.82	0.44	7
	Mar. 1914	0.30	20.16	20.46		
	April "	0.76	19.31	20.07	0.39	13
	May "	0.44	20.22	20.66		
	June "	0.43	20.39	20.82	-0.16	7
Broadbalk wilderness	Nov. 1913	0.58	20.62	21.20		
	Dec. "	0.64	20.17	20.81	0.39	11
	Dec. "	0.53	20.19	20.72		
	Jan. 1914	0.32	20.55	20.87	-0.15	9
Broadbalk unmanured	Nov. 1913	0.35	20.56	20.91		
	Dec. "	0.29	20.27	20.56	0.35	10
	Mar. 1914	0.29	20.28	20.57		
	April "	0.34	19.85	20.19	0.38	17
Hoos fallow	Nov. 1913	0.33	21.06	21.39		
	Dec. "	0.32	20.57	20.89	0.50	8
	Feb. 1914	0.04	20.85	20.89		
	May "	0.05	20.73	20.78	0.11	11
Hoos wheat	Nov. 1913	0.11	20.90	21.01		
	Dec. "	0.10	20.76	20.86	0.15	8
	Mar. 1914	0.03	20.75	20.78		
	April "	0.10	20.58	20.68	0.10	7

At least two cases occur in which the oxygen decreases to a greater extent than the CO<sub>2</sub> increases:

- (1) At times of active nitrification.
- (2) After heavy rainfall.

In the first case the falling off of oxygen is partly at any rate the result of oxidations such as the production of nitrate which do not yield a volume of CO<sub>2</sub> equal to that of the oxygen absorbed. Table V gives the results obtained for all the periods of rapid nitrate accumulation: in all except two the fall in oxygen is greater than the rise of CO<sub>2</sub>.

The second case is seen in wet weather particularly in February, 1913 and 1914, but it reaches its maximum development on Geescroft during the period when the soil lies waterlogged; the oxygen then falls as low as 2.6 per cent. but the CO<sub>2</sub> does not rise above 9.1 per cent. There is no evidence of rapid biochemical change; it appears more probable that the CO<sub>2</sub> is being dissolved in the soil water.

There are still other instances where the fall in oxygen precedes the rise in CO<sub>2</sub>: these are readily seen by inspecting the curves.

A third case presents more difficulty and has not yet been satisfactorily explained. Reference to the figures shows that several periods occur when the oxygen and CO<sub>2</sub> rise simultaneously: such are May-June 1913 and April 1914 on Broadbalk unmanured plot (Fig. 1), February, April and November 1913 on Broadbalk dunged plot (Fig. 2), March, April and October 1913 on Broadbalk wilderness (Fig. 3), etc. The phenomena suggest an evolution of CO<sub>2</sub> from the water or colloids in the soil.

In general the oxygen falls below that present in atmospheric air (20.97 per cent.) but in a few cases it exceeds this amount<sup>1</sup>. The occurrence is so rare that we have been unable to make a satisfactory investigation, but we incline to the view that the additional oxygen comes dissolved in the rain (p. 23). The following are instances:

		% CO <sub>2</sub>	% O <sub>2</sub>	% N <sub>2</sub>
Hoos field wheat .. ..	10 Nov. 1913	0.69	21.01	78.30
		0.10	21.10	78.78
		0.19	21.71	78.10
Broadbalk wheat (dunged plot)	10 Nov. 1913	0.11	21.19	78.70
Geescroft .. .. .	10 Nov. 1913	0.19	21.21	78.60

<sup>1</sup> See also Appendix, Table XI, Hoos field fallow.

## THE CAUSES OF FLUCTUATIONS OF COMPOSITION OF SOIL AIR.

A. *The variations due to season.*

These fluctuations consist in a rise to a maximum  $\text{CO}_2$  content in late spring, a fall to a minimum in summer, a rise to a second maximum in late autumn and a fall to a minimum in winter. The oxygen content varies in the inverse sense, reaching minimum values in spring and autumn and maximum values in summer and winter.

All the curves show the same general shape when plotted over the year; proving that the effect of season completely overrides the effect of various soil treatments. Field experiments alone do not enable us to disentangle all the factors, but we took measurements for the purpose of discussing the effect of temperature and moisture content.

*Effect of temperature.* This can be studied from Fig. 7 where the mean soil temperatures taken from the continuous recording soil thermometer are plotted along with the  $\text{CO}_2$  in the soil air from the Broadbalk unmanured plot.

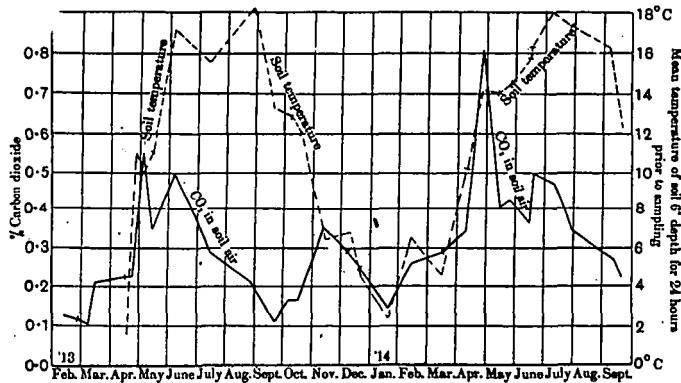

Fig. 7. Curves showing percentage of  $\text{CO}_2$  in air of Broadbalk unmanured plot and mean soil temperature (at 6" depth) for 24 hours previous to sampling.

Beginning with the middle of April, 1913, when soil temperatures were first taken, it is seen that the temperature curve runs closely with the  $\text{CO}_2$  curve up to the early part of May, they then part company and show no more resemblance till November. From that time, however, up to early May, there is a close general resemblance but this ceases from then onwards. Thus we can infer that the temperature is the dominating factor in determining the amounts of  $\text{CO}_2$  production from November to May.

It is clearly not the only factor for the parallelism is not complete: a rise in temperature in spring is more potent to increase the output of  $\text{CO}_2$  than a similar rise later on. Thus the values for temperature and  $\text{CO}_2$  in May and June no longer show the agreement obtained earlier: the  $\text{CO}_2$  maximum in May being above that in June while the temperature maxima fall the other way. These differences in detail indicate that other factors are operating, but they do not weaken the main conclusion that *from November to May the temperature determines the rate of  $\text{CO}_2$  production in the soil*<sup>1</sup>.

The dunged plots and the wilderness show the same general relationships, but again there are differences in detail, the  $\text{CO}_2$  and temperature curves parting company earlier in the summer than on the unmanured plot. The main obvious difference between the plots is that the crop is larger on the dunged plot and the wilderness than on the unmanured plot, and the bearing of this factor will become evident later on.

From June to November, however, the temperature is not the main factor for the curves show no kind of similarity.

*Effect of Moisture.* A comparison of moisture content and  $\text{CO}_2$  content is made in Fig. 8. The moisture determinations only began in June 1913, so that the curve does not run as long as that for temperature but it shows no connection with the  $\text{CO}_2$  curves except during a few months in summer. The moisture is low during June, July and August of 1913 when the  $\text{CO}_2$  is falling: it rises in September and October when the  $\text{CO}_2$  first falls and then rises, it is steadily high from November to March 1914 during which the  $\text{CO}_2$  first falls and then rises; it falls in April while the  $\text{CO}_2$  rises and falls low during summer when the  $\text{CO}_2$  also is low.

Thus moisture does not have nearly so marked an effect as temperature, and it only shows any relationship to the  $\text{CO}_2$  during the summer months July to September.

The extreme case of water logged soil is dealt with on p. 32.

<sup>1</sup> The failure to find on some of the plots a maximum  $\text{CO}_2$  content in May 1914 of the same order as the value obtained in 1913 may be attributed to the fact that quite unwittingly we allowed a favourable temperature period to pass without taking any samples. We made determinations on May 15 and again on May 25, but during the interval there came a rise in temperature which we missed.

May 1914	15th	16th	17th	18th	19th	20th	21st	22nd	23rd	24th
Soil temperature at depths of 6 in. °C.	15.5	15.1	16.1	17.3	16.9	17.9	19.0	20.0	16.1	14.6

*Rainfall.* If instead of taking the percentage of moisture, we plot rainfall for the week preceding the date of sampling, we obtain a somewhat closer relationship with the  $\text{CO}_2$  curves (Fig. 9). The May maximum (1913) is seen to coincide with a period of high rainfall: the

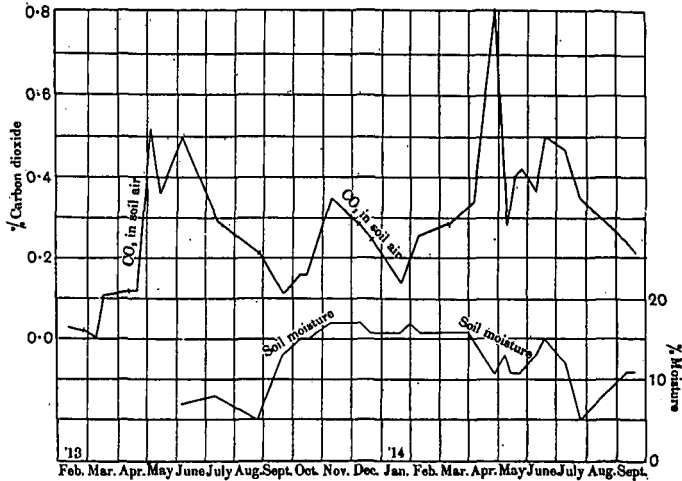

Fig. 8. Curves showing percentage of  $\text{CO}_2$  in air of Broadbalk unmanured plot and soil moisture to a depth of 9".

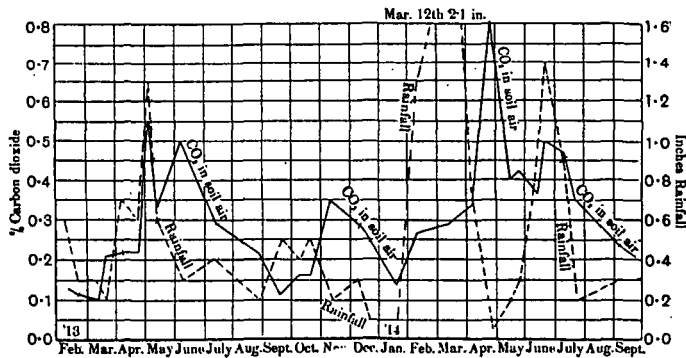

Fig. 9. Curves showing percentage of  $\text{CO}_2$  in air of Broadbalk unmanured plot, and rainfall for seven days preceding day of sampling.

October maximum follows after a second high rainfall and the intervening summer minimum is in a dry period: the April (1914) and the June maxima occur with other high rainfall periods. These are not simple moisture effects, for they are not brought out so clearly on the moisture curve, and we have to seek some other explanation. Two factors appear

to come into play. In the first place the rain does not immediately distribute itself throughout the soil but produces a more or less saturated layer which seals the surface and prevents the escape of  $\text{CO}_2$  from the soil air. Further, rain appears to be nearly saturated with dissolved oxygen. We have already seen that the dissolved atmosphere in the soil tends to lose oxygen more rapidly than to gain it and in consequence is largely anaerobic. A large fall of rain bringing with it oxygen in solution affords the possibility of partially renewing the dissolved atmosphere and giving the organisms a new lease of activity. In time, however, the oxygen is used up and the activity falls off even though the moisture remains constant. This effect is probably most marked when the soil is dry and the new dissolved atmosphere can most completely replace the old one. We could find no determinations of the amount of dissolved oxygen in rain water but a number of analyses of stream waters have been made by the Sewage Commission, and they show that on an average about ten parts per million by weight of dissolved oxygen is present. If we suppose that rain contains approximately the same amount then 1 inch of rain brings down  $2\frac{1}{4}$  lbs. of oxygen per acre; this if converted into  $\text{CO}_2$  would add 0.8 to the normal 0.2 per cent. by volume and make the total up to 1 per cent. In addition the rain itself brings down a certain amount of  $\text{CO}_2$ , but not much, and considerably less than the amount of oxygen.

*Relation between soil air and atmospheric air.* The experiments described in this section show that  $\text{CO}_2$  is produced at maximum rates in spring and in autumn and at minimum rates in summer and winter. As it is constantly escaping from the soil into the atmosphere we should naturally expect to find that the  $\text{CO}_2$  in the atmospheric air also reaches maximum amounts in spring and autumn, minimum amounts in summer and winter.

Systematic determinations of the amount of  $\text{CO}_2$  in atmospheric air are not numerous, but those made prior to 1899 were collected by Letts and Blake in their paper already quoted<sup>1</sup>. A statistical examination of the data shows that, as far as they can be relied upon, they indicate an increase in atmospheric  $\text{CO}_2$  during the period March–May, a falling off during the period May to August, and a rise during the period October to January. Thus a very close agreement is obtained with our soil results.

<sup>1</sup> *Proc. Roy. Soc. Dublin*, 1900, 9, 107–270 and especially pp. 205 *et seq.*



B. *The effect of organic matter.*

Fig. 10 shows the comparison between two plots in Broadbalk wheat field one of which is unmanured while the other receives every September a dressing of 14 tons of farmyard manure. The comparison is only strict during the winter period September to March or April when the

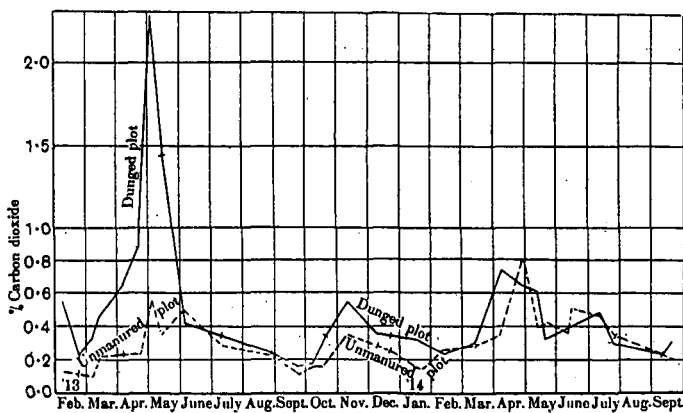

Fig. 10. Comparison of CO<sub>2</sub> content of unmanured plot with plot receiving farmyard manure, Broadbalk field.

crop is so small that it can safely be neglected; from May on to harvest time complication arises from the fact that the dunged plot carries a dense crop while the unmanured plot does not. During winter the air from the dunged plot consistently contains the larger quantity of CO<sub>2</sub>; we can carry the strict comparison from March onwards by taking the fallow part of the dunged plot and the unmanured fallow on Hoos field, which closely resembles the unmanured plot in Broadbalk:

	May 15	May 25	June 10	June 12	June 13	July 7	July 27
Dunged fallow (Broadbalk)	0.22	0.32	0.17	0.36	0.36	0.36	0.35
Unmanured fallow (Hoos)	0.10	0.07	0.08	0.07	0.10	0.08	0.09

The dunged plot still gives the higher result so that the effect of the manure is clearly to increase the amount of CO<sub>2</sub> in the soil air throughout the year.

The persistence of this increase is its chief characteristic, and during most of the year it does not assume very great dimensions nor does it alter the shape of the curve relative to the unmanured land. The actual percentages of CO<sub>2</sub> during the month before and the month after ploughing in are as follows :

	Dunged plot before ploughing in	Unmanured plot		Dunged plot after ploughing in	Unmanured plot
September 22	0.17	0.11	November 10	0.54	0.35
October 6	0.18	0.16	December 9	0.35	0.29
„ 17	0.34	0.16	„ 12	0.34	0.25

Considerably larger differences however were observed during the spring both in CO<sub>2</sub> and oxygen in 1913 and in oxygen in 1914.

### C. *The effect of a growing crop.*

As already pointed out (p. 9) there has been considerable disagreement as to the relative amounts of CO<sub>2</sub> in the air of cropped and of uncropped soils. Critical examination of the older work shows that much of the discussion was irrelevant because the conditions in the various experiments were not comparable. A cropped plot differs in physical state, moisture content, temperature, etc. from uncropped land and when the case is pushed to an extreme and a comparison is instituted between grass land and arable land there arises a further complication due to the difference in organic matter content of the two soils.

The usual method has been to set up a comparison between cropped and fallow portions of the same plot. We have done this in two fields. Figs. 4 and 5 and Table VI give the detailed results and Fig. 11 a simpler comparison for the Hoos wheat and fallow plots. These are made to alternate each year: the land has been unmanured since 1851 and now yields a small crop averaging 16 bushels of wheat per acre. All through the period of active growth (June to August) the cropped plot is the richer in CO<sub>2</sub> and it maintains its superiority even after the crop is cut and right up to the time when the land is ploughed. Then the CO<sub>2</sub> sinks to a low level and remains low throughout the period of fallow; it rises again as soon as the land comes into crop. The physical differences in the plots, however, are considerable. The fallow land is left rough and is not harrowed, it is occasionally cultivated to kill weeds; thus it readily allows of the escape of CO<sub>2</sub>. The cropped land has to

be got into a tilth for the seeding and it speedily becomes compact and less favourable to gaseous diffusion.

During the current year the top half of Broadbalk field has been fallowed and a comparison was made between the fallow and the

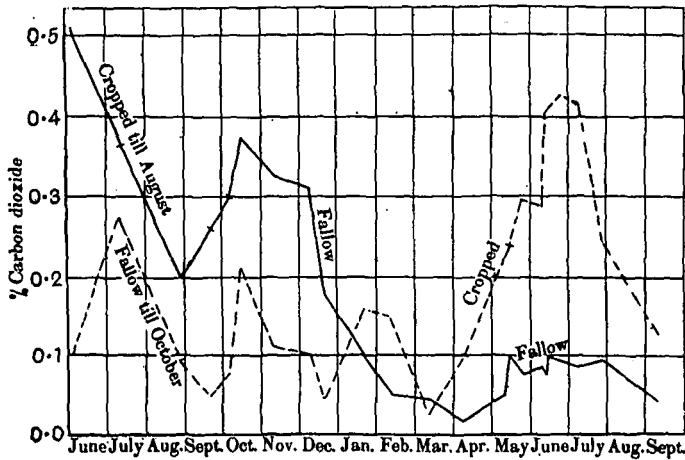

Fig. 11. Curves showing percentage of CO<sub>2</sub> in air of Hoos wheat and fallow plots.

cropped portions of the dunged plot. Here the conditions are different from those in Hoos field; the soil contains considerably more organic matter and does not become very compact: the difference in physical condition between the cropped and fallow portions therefore is not nearly so marked (although it still exists) and a stricter comparison is possible. Moreover the crop (which was fairly dense) did not apparently affect the temperature of the soil, and from May to July practically no differences were observed<sup>1</sup>. The moisture content, however, was affected, the percentage of water being:

	June 12	July 7	July 27	
Fallow portion	18	20	12	per cent. of water
Cropped portion	19	17	9	

<sup>1</sup> The actual readings (6" depth) were:

	May 15	May 25	June 10	June 12	June 13	July 7	July 27
Fallow portion ..	12°	11°	12°	12°	14°	15°	15°
Cropped portion ..	12°	11°	12°	12°	14°	15°	14°

Thus the soil conditions are still not entirely comparable but on the whole they are more so than on Hoos field. The percentages of CO<sub>2</sub> in the soil air were:

	May 15	May 25	June 10	June 12	June 13	July 7	July 27
Fallow portion	0.22	0.32	0.17	0.36	0.36	0.36	0.35
Cropped portion	0.61	0.32	0.35	0.48	0.42	0.48	0.30

Now the crop was considerable (30.4 bushels per acre), yet the increase in CO<sub>2</sub> over that in the fallow plot is not only no greater than in Hoos field but it is not usually (except on May 15) much larger than the error of experiment. Hence it appears that the effect of the growing crop in increasing the amount of CO<sub>2</sub> in the soil air is not great.

We can make the comparison in a different way so as to reduce in another direction the differences in physical state between the plots. The Broadbalk dunged and unmanured cropped plots both receive similar cultivations and treatment apart from manuring: both are equally exposed to the consolidating effect of the weather though the unmanured land does actually become the more closely packed. The dunged land possesses a large quantity of organic matter and carries a dense crop, both conditions favourable for a high percentage of CO<sub>2</sub> in soil air, yet as a matter of fact this high percentage is not obtained, and in summer when one would expect the maximum differences from the unmanured plot there is practically no difference at all<sup>1</sup>.

<sup>1</sup> On the following occasions the unmanured plot gave a higher CO<sub>2</sub> content than the dunged plot in Broadbalk field:

	Date	Mean composition of soil air		Moisture Per cent. in soil	Temperature °C.	
		% CO <sub>2</sub>	% O <sub>2</sub>		Air	Soil
Unmanured plot	3 June 1913	0.50	20.77	7		18
Dunged plot		0.42	20.56	11	22	15
Unmanured plot	29 April 1914	0.81	19.98	11	10	—
Dunged plot		0.65	20.08	16		—
Unmanured plot	25 May 1914	0.42	—	11	10	12
Dunged plot		0.32	—	13		11
Unmanured plot	13 June 1914	0.50	19.80	15	21	15
Dunged plot		0.42	20.38	19		14
Unmanured plot	27 July 1914	0.35	—	5	14	16
Dunged plot		0.30	—	9		14

Determinations of the amount of CO<sub>2</sub> in the soil air of grass land are given in Table VII. The results show that more CO<sub>2</sub> is usually present than in arable land and the oxygen content is lower. But no strict comparison with arable land can be made because of the great

TABLE VII. *Composition of soil air of grassland. Percentage by volume.*

A. *Pasture used for grazing.*

Date	CO <sub>2</sub>	O <sub>2</sub>	N <sub>2</sub>
Nov. 6, 1912 .. ..	1.01	18.72	80.27
"   14   "   "   "   "	1.59	18.12	80.29
"   20   "   "   "   "	1.99	—	—
"   21   "   "   "   "	1.35	—	—
"   22   "   "   "   "	1.90	—	—
Dec. 2, 1913 .. ..	3.34	15.18	71.48
Jan. 30, 1914 .. ..	1.46	18.44	80.10
Jan. 30, 1914, 18 in. deep	1.64	17.87	80.49

B. *Geescroft Wilderness.*

Date	CO <sub>2</sub>	O <sub>2</sub>	N <sub>2</sub>	CO <sub>2</sub>	O <sub>2</sub>	N <sub>2</sub>	Bacterial numbers, millions per gram	N as nitrate, parts per million	
Dec. 19, 1912	1.5	15.8	82.7						
Jan. 13, 1913	0.7	16.6	82.7						
Jan. 24 "	3.1	6.2	90.7						
Feb. 11 "	0.7	19.0	80.3						
Feb. 26 "	2.0	16.4	81.6						
<i>under Festuca ovina.</i>				<i>under Aira caespitosa</i>					
Mar. 13, 1913	3.9	13.0	83.1	1.1	19.4	79.5			
April 14 "	4.5	9.2	86.3	—	—	—			
April 24 "	9.1	2.6	88.3	1.3	19.1	79.6			
May 2 "	5.4	9.0	85.6	3.9	10.6	85.5			
May 13 "	7.6	8.6	83.8	3.0	14.5	82.5			
June 3 "	1.6	19.7	78.7	1.0	20.0	79.0	8	3	
July 11 "	0.7	20.5	78.8	0.6	20.5	78.0	8	4	
Aug. 29 "	0.4	20.5	79.1	0.4	20.5	79.1	9	4	
Sept. 22 "	0.7	20.3	79.0	0.8	20.2	79.0	17	2	
Oct. 6 "	0.8	20.3	78.9	0.9	20.1	79.0	—	5	
Oct. 17 "	0.5	20.6	78.9	1.2	19.4	79.4	14	3	
Nov. 10 "	1.0	19.7	79.3	0.9	19.8	79.3	10	1	
Dec. 9 "	2.5	16.2	81.3	2.5	16.4	79.1	10	8	
Dec. 22 "	1.2	19.0	79.7	2.2	16.7	81.1	17	6	
Jan. 8, 1914	—	—	—	—	—	—	13	—	
Jan. 20 "	1.0	19.0	80.0	0.9	19.5	79.6	8	11	
Jan. 30 "	—	—	—	—	—	—	13	7	
Feb. 12 "	1.8	14.2	84.0	1.6	14.8	83.6	—	6	

difference in amount and composition of the organic matter present in the soil. The closest comparison we can set up is between two of the Broadbalk plots: an arable plot receiving 14 tons of dung annually and carrying each year a good crop of wheat, and an adjacent plot known as the wilderness which has remained undisturbed since 1882 and now carries a dense growth of grasses, clovers, weeds, etc., only young trees and bushes being removed. The percentages of  $\text{CO}_2$  in the soil air are plotted in Fig. 12. There is no great difference between the two curves. In April and early May the dunged plot contains more  $\text{CO}_2$ , from September to early January it contains less, but during these months it has been ploughed up and left loosely exposed to the atmosphere for a time prior to seeding. But the differences rarely

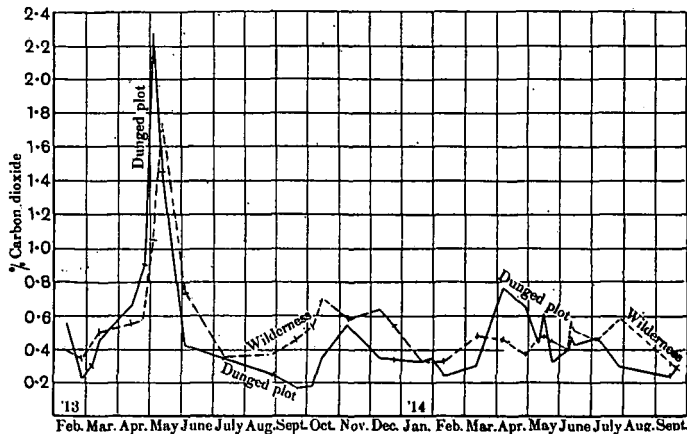

Fig. 12. Curves showing  $\text{CO}_2$  in soil air of Broadbalk dunged and wilderness plots.

exceed 0.3 per cent. When therefore the soil conditions are comparable both as to the state of packing and to the amount of organic matter the difference between grass and arable land is less than might be expected. The result is all the more significant when it is remembered that the air of the unmanured plot is as rich in  $\text{CO}_2$  during summer as the air of the dunged plot.

Taking them as a whole, these observations indicate that a growing crop *per se* has no very marked effect in increasing the amount of  $\text{CO}_2$  in the soil air. Comparison is rendered difficult by the numerous differences between cropped and fallow land or between grass and arable land, which can only partially be eliminated; if an ordinary grass field is compared with an ordinary arable field considerable differences are found, but when the conditions are made more nearly

alike the effect of the crop is not very great. Absolute identity of conditions has not been attained, and we cannot yet be certain whether the small effect of the crop still observed is due to uneliminated soil differences such as the removal of water by the growing crop which thus facilitates the escape of  $\text{CO}_2$  evolved from the plant roots; or to some direct interference of the growing crop with bacterial activity in the soil.

A wholly different argument in a previous paper<sup>1</sup>, led to the conclusion that the growing plant interferes with bacterial activity.

Before leaving this subject attention must be directed to one interesting point in connection with the two Broadbalk plots, the dunged arable and the wilderness. The arable plot shows a persistent loss of nitrogen amounting to over 100 lbs. per acre per annum, apparently

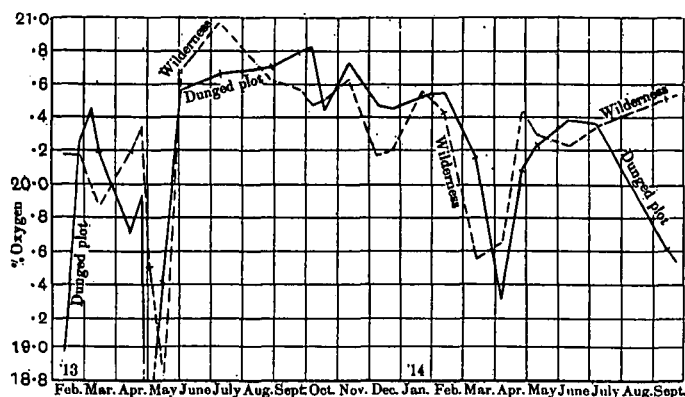

Fig. 13. Curves showing  $\text{O}_2$  in soil air of Broadbalk dunged and wilderness plots.

not wholly by drainage. The wilderness, on the other hand, shows a persistent gain of nitrogen amounting approximately to 100 lbs. per acre per annum. We have hitherto been inclined to attribute this remarkable difference to a supposed greater aeration influencing the biochemical changes in the arable land. It is therefore of special interest to compare the oxygen content of the air from the two plots: this has been done in Fig. 13, from which it appears that there is little if any difference between them.

*Amount of  $\text{CO}_2$  under plants of various species.* On some of the Rothamsted grass plots and especially those that have become acid there is a tendency for certain species to segregate; determinations were therefore made of the percentage of  $\text{CO}_2$  in the soil air of these

<sup>1</sup> 'The nature and amount of the fluctuations in nitrate contents of arable soils,' *J. Agric. Sci.* 1914, 6, 18-57.

various patches. It is found that there is a perceptible falling off of oxygen and rise in CO<sub>2</sub> in passing from a neutral matrix to a "sour" patch (indicated by the presence of rumex or in extreme cases by the total absence of all vegetation). But a patch of a solitary species occurring on a neutral plot such as plot 7 shows no such difference. The results are:

Per cent.	Plot 7		Plot 5 N.		Plot 5 S.			Plot 4 <sup>a</sup>		Plot 11-1	
	Under matrix	Under spirea	Under matrix	Under dactylis	Under matrix	Under dactylis	Under dactylis and rumex	Under matrix	Under bare patch	Under matrix	Under bare patch
CO <sub>2</sub>	1.5	1.4	1.2	1.5	1.3	1.1	2.0	2.1	1.5	1.2	2.3
Oxygen	19.3	20.0	20.0	19.7	20.0	20.1	19.5	19.0	19.5	20.1	18.5

Samples taken May 24th, 1913.

Another field where segregation occurs is Geescroft which is liable to become waterlogged in winter owing to the absence of calcium carbonate from the soil and the consequent deflocculation of the clay. During normal moist or dry conditions the soil air from the various patches is similar in composition and resembles that from the other fields. But in very wet conditions marked differences set in, the oxygen falling and the nitrogen<sup>1</sup> rising very considerably in amount; this happens particularly under the patches of *Festuca ovina* the roots of which form a densely matted tangle near the surface, but it is less marked under the patches of *Aira caespitosa* the roots of which form a bristly mass more readily allowing gaseous diffusion. The results are plotted in Fig. 6, they are as follows:

*Wet conditions*

1913	% CO <sub>2</sub>		% O <sub>2</sub>		% N <sub>2</sub>	
	Aira	Festuca	Aira	Festuca	Aira	Festuca
March 13	1.1	3.9	19.4	13.0	79.5	83.1
April 14	—	4.5	—	9.2	—	86.3
April 24	1.3	9.1	19.1	2.6	79.6	88.3
May 2	3.9	5.4	10.6	9.0	85.5	85.6
May 13	3.0	7.6	14.5	8.6	82.5	83.8

<sup>1</sup> Examination for hydrogen or methane has so far led to negative results.



*Dry conditions*

1913	% CO <sub>2</sub>		% O <sub>2</sub>		% N <sub>2</sub>	
	Aira	Festuca	Aira	Festuca	Aira	Festuca
June 3	1.0	1.6	20.0	19.7	79.0	78.7
July 11	0.6	0.7	20.5	20.5	78.9	78.8
August 29	0.4	0.4	20.5	20.5	79.1	79.1
September 22	0.8	0.7	20.2	20.3	79.0	78.9
October 6	0.9	0.8	20.1	20.3	79.0	78.9

The low amount of CO<sub>2</sub> relative to the oxygen used up has already been discussed (p. 19).

*Minor fluctuations in composition of the soil air.*

We now turn to a consideration of the minor fluctuations in composition of the soil air. These differ fundamentally from the major fluctuation hitherto dealt with in as much as they are probably not associated with the production of CO<sub>2</sub> in the soil but only with variations in the agencies causing loss. They are brought about by two causes:

(1) Variations in the soil itself: shown in Table XI (p. 41) and discussed on p. 4.

(2) Variations in meteorological and cultivation conditions.

The only satisfactory way of dealing with the effect of meteorological conditions on the soil atmosphere is by statistical methods, but although we have many records we do not feel that they are sufficiently numerous for the purpose. We have, however, tested certain broad and obvious possibilities, the data for which are found in Table VI (p. 46).

(a) *Rapid change of temperature.* It has happened on a warm day preceded by a frosty night, *i.e.* where the temperature altered quickly and considerably, that the soil air approximated closely in composition to atmospheric air indicating that it had been largely replaced by atmospheric air. Instances occur on January 13th and February 26th, 1913.

(b) *High rainfall.* In view of the quantity of bicarbonates in drainage water it is important to ascertain whether high rainfall appreciably diminishes the amount of CO<sub>2</sub> in the soil air. The observations do not yield any very definite results: in some cases the immediate effect is to reduce the CO<sub>2</sub> but not always, while usually the subsequent

effect is to increase it (p. 23, Fig. 9). The following data serve as illustrations:

Date .. ..	June 10th	June 12th	June 13th
Rainfall of previous 24 hours ..	0.33 in.	—	0.65 in.
CO <sub>2</sub> per cent. in soil air:—			
Broadbalk unmanured plot ..	0.36	0.37	0.50
„ dunned plot ..	0.40	0.48	0.43
„ wilderness ..	0.40	0.58	0.51
Hoosfield wheat ..	0.28	0.41	0.43
„ fallow ..	0.08	0.07	0.10

These observations confirm the older results of Fodor<sup>1</sup>.

(1) *Strong winds.* On several occasions, e.g. February 3rd, March 7th, 1913, samples were taken directly after a windy night but there was nothing at all to indicate that the composition of the air had been affected by the wind. A current of air passing rapidly over the soil might have been expected to draw out the soil air, but apparently it does not. Probably the force is insufficient, the layer of air in contact with the surface of the soil moves less quickly than the layers a few inches above. Moreover any removal of air by this process from the surface layers of the soil probably leads to an upward movement of air rich in CO<sub>2</sub> from the lower depths.

(2) *Change in barometric pressure.* Fodor<sup>2</sup> found that the CO<sub>2</sub> in soil air rose with falling barometer at three stations out of four where investigations were made. In the only continuous experiment we made we were fortunate in happening upon a time when the barometer was rapidly falling and we also obtained a rise in CO<sub>2</sub> during the period. But when the whole of our CO<sub>2</sub> figures are plotted against barometric pressures or even against changes in barometric pressure no consistent relationship can be observed such as is obtained with rainfall, temperature, etc., so that the influence of barometric pressure appears to be only minor and easily swamped by other factors.

(3) *Night and day.* Fodor<sup>3</sup> and Wollny<sup>4</sup> thought they had evidence that CO<sub>2</sub> streams out from the soil air at night but we can find no indication of any greater loss by night than by day. Samples drawn from the same 5 holes at consecutive 3-hour intervals over a period of

<sup>1</sup> Josef Fodor, *Hygienische Untersuchungen über Luft, Boden und Wasser*, Braunschweig, 1881, p. 130.

<sup>2</sup> Fodor, *ibid.* p. 135.

<sup>3</sup> Fodor, *ibid.* p. 53.

<sup>4</sup> Wollny, *Forsch. auf dem Gebiete der Agrik.-Physik*, 1885, 8, 417.

33 hours failed to show any systematic variation as between the day and the night. The results are given in Table VIII. The CO<sub>2</sub> tends to rise and the oxygen to fall from the 18th hour onwards (*i.e.* from 3.30 a.m. on the 15th) when the barometer is steadily falling, but there is no sign of any relationship with the temperature either of the air or the soil.

TABLE VIII. *Hourly fluctuations in composition of soil air, 3-hour periods over 33 consecutive hours.*

Hour .. ..	0	3	6	9	12		
	A.M.	P.M.	P.M.	P.M.	P.M.		
Time Nov. 14 ..	9.30	12.30	3.30	6.30	9.30		
% CO <sub>2</sub> (mean) ..	0.11	0.13	0.11	0.15	0.13		
% O <sub>2</sub> (mean) ..	20.69	20.82	20.65	20.70	20.61		
Barometer mm. ..	742	746	747	748	749		
Air temp. °C. ..	5	6	2	-1	-2		
Soil temp. °C. ..	2	6	6	5	5		

Hour .. ..	15	18	21	24	27	30	33
	A.M.	A.M.	A.M.	A.M.	P.M.	P.M.	P.M.
Time Nov. 15	12.30	3.30	6.30	9.30	12.30	3.30	6.30
% CO <sub>2</sub> (mean)	0.13	0.13	0.14	0.16	0.16	0.19	0.18
% O <sub>2</sub> (mean) ..	20.61	20.62	20.52	20.54	20.51	20.42	20.43
Barometer mm. ..	747	744	738	733	731	730	729
Air temp. °C. ..	0	1	1	1	13	8	6
Soil temp. °C. ..	5	5	5	5	7	6	5

(4) *Cultivation.* We have not made systematic investigations into the effects of the various cultivation operations, but we find that ploughing usually increases the percentage of oxygen and diminishes the CO<sub>2</sub> in the soil air, the fall in CO<sub>2</sub> being particularly marked when the ploughing is done early. The details are given in Table IX, where also are set out the analytical data for the uncultivated wilderness.

*The relation between carbon dioxide production, nitrate formation and bacterial numbers.*

The curves showing the amounts of carbon dioxide in the soil air and of nitrate in the soil are so similar in character as to justify the view that both essentially represent the rates of formation (p. 12). Closer comparison of the curves with those for bacterial numbers

brings out several important features which we must now proceed to discuss.

Fig. 14 shows the rainfall, bacterial numbers, carbon dioxide and nitrate for the Broadbalk dunged plot, which is perhaps the most convenient for our purpose by reason of the high values it yields. Beginning in July, 1913, the bacterial numbers follow the rainfall very closely till October and less closely till January, the diminishing rainfall

TABLE IX. *Percentage composition of soil air before and after cultivation operations.*

Date	Uncultivated land Wilderness		Cultivated land				Hoos Fallow Wheat	
			Broadbalk Dunged		Broadbalk Unmanured			
	CO <sub>2</sub>	O <sub>2</sub>	CO <sub>2</sub>	O <sub>2</sub>	CO <sub>2</sub>	O <sub>2</sub>	CO <sub>2</sub>	O <sub>2</sub>
July 11 ..	0.36	20.97	0.35	20.66	0.29	20.79	0.27	20.66
			Wheat cut		Wheat cut		Ploughed	
August 29 ..	0.37	20.62	0.24	20.70	0.22	20.73	0.09	20.84
			Ploughed and harrowed		Ploughed and harrowed			
September 22	0.46	20.57	0.17	20.79	0.11	20.83	—	—
October 6 ..	0.53	20.47	0.18	20.81	0.16	20.82	—	—
					Ploughed			
October 17 ..	0.70	20.50	0.34	20.43	0.16	20.72	0.21	21.30
			Ploughed, harrowed and drilled		Harrowed and drilled		Drilled with wheat	
November 10	0.58	20.62	0.54	20.72	0.35	20.56	0.11	20.90
December 22	—	—	—	—	—	—	0.17	20.44
							Ploughed	
January 20 ..	—	—	—	—	—	—	0.10	20.92

of July and August being accompanied by a fall in bacterial numbers, the September rain by a rapid rise, and so on. The CO<sub>2</sub> curves also follow in the same way but later in point of time and they are somewhat smoothed out: thus they do not show the kink in October. The nitrate curves again show the same rise but still later; in comparing them with the others, however, it must be remembered that conditions of drought which favour a decrease of bacteria through death and of CO<sub>2</sub> through diffusion have no effect in reducing the amounts of nitrate: thus during

July and August the nitrates increase instead of falling like the CO<sub>2</sub>. But in November and December the nitrates rise sharply and keep high until the heavy February rains<sup>1</sup>, when they fell to a minimum just as do the bacterial numbers and the carbon dioxide.

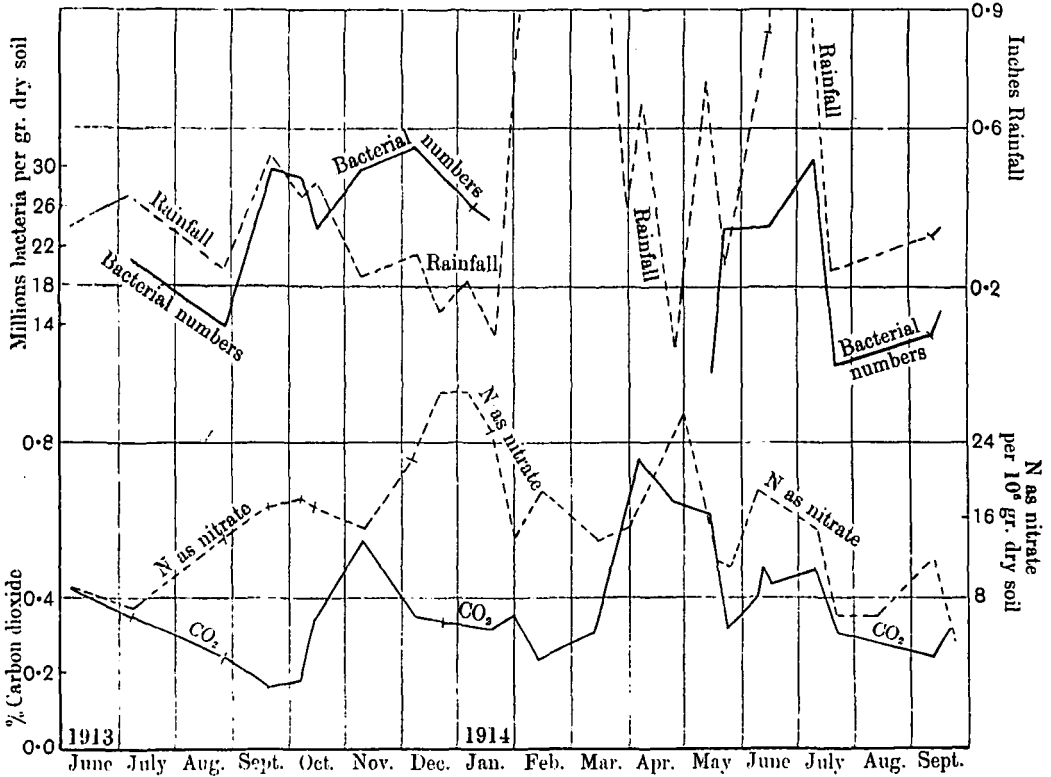

Fig. 14. Curves showing rainfall, bacterial numbers in soil, CO<sub>2</sub> in soil air and nitrate in soil of Broadbalk dunged plot.

<sup>1</sup> The rainfall for December 1913 and January 1914 was considerably below the average so that the washing out of nitrate began later than usual. The rainfall figures are:

	December	January
Average 1853-1913	2.44	2.35
This year ..	0.88	0.88

It is interesting to note that, when the drains began to run in February 1914, the drainage water was of approximately the same order of concentration as after the similar winter conditions of 1879-80:

N as nitrate in drainage water from Plot 2 (dunged)		
February 1914	26.8	29.7 parts per million
„ 1880	27.3	„ „

Unfortunately there was a break in the bacterial counts during the winter months, but the other observations were made. In March, 1914, there occurred a high rainfall, followed by a rise in  $\text{CO}_2$  and somewhat later by a rise in nitrate: in April the  $\text{CO}_2$  falls, but in May and June there is a sharp increase in rainfall and in bacterial numbers, followed by an increase of  $\text{CO}_2$  and of nitrate.

If we take the unmanured (Fig. 1) instead of the dunged plot we obtain similar but numerically smaller results. The wilderness (Fig. 3) also shows the same general phenomena, but the spring rise in the nitrate is considerably flattened down in consequence of the rapid absorption by the plants; the autumn rise, however, is seen, and as before it comes after the rise in  $\text{CO}_2$  and this in turn after the rise in bacteria. Again, the Hoos wheat and fallow plots (Figs. 4 and 5) show like similarity between bacterial numbers,  $\text{CO}_2$  and nitrates, especially during the fallow period. The fluctuations are not great—the land having received no manure for many years is very impoverished—and it would be unsafe to attach too much importance to some of them, but they all go in the same direction. During the time when the land carries a crop of wheat (Fig. 5) the nitrate curve is flattened from April to July; while on the other hand the loosening of the land during the fallow period causes a flattening of the  $\text{CO}_2$  curve.

The general conclusion is that the fluctuations in bacterial numbers, in  $\text{CO}_2$  content and in nitrates in the soil are all of the same general character, and this character is mainly impressed by seasonal factors: other conditions such as manuring, cropping, etc., may pull out or flatten the curves but they do not alter their general shape. The production both of nitrates and of  $\text{CO}_2$  attains a maximum in late spring or early summer, a minimum in summer, a maximum in late autumn and a minimum in winter<sup>1</sup>; the numbers of bacteria fluctuate in the same way in summer, autumn and winter. When the autumn rains came after the dry summer conditions, the bacteria immediately responded by rapid multiplication: then there came an increase in the amount of  $\text{CO}_2$  in the soil air and finally an increase in the amount of nitrates. This order seems to be pretty general.

The spring and autumn periods of maximum biochemical activity in the soil are clearly of great significance in soil management.

<sup>1</sup> Similar seasonal fluctuations in nitrate content are recorded in the paper already quoted in *J. Agric. Sci.* 1914, 6, 18–57.

## APPENDIX.

I. *Method of collecting and analysing the soil air.*

The apparatus used for collecting the soil air is shown in Fig. 15; it was used by Hall and Russell in their investigations of the air of Romney marsh soils. It consists of a hollow cylindrical steel tube (*A*) 2 feet long,  $\frac{5}{8}$  in. outside and  $\frac{3}{8}$  in. inside diameter to which is welded a side tube (*R*) 2½ inches from the top to allow of the air being withdrawn from the nozzle (*S*). The top of the tube is strengthened by a cap (*B*). A solid cylindrical rod (*N*)  $\frac{3}{8}$  in. in diameter with a flat side  $\frac{1}{8}$  in. wide running its whole length fits tightly into the hollow tube; it is provided at the bottom with a collar  $\frac{1}{8}$  in. wide.

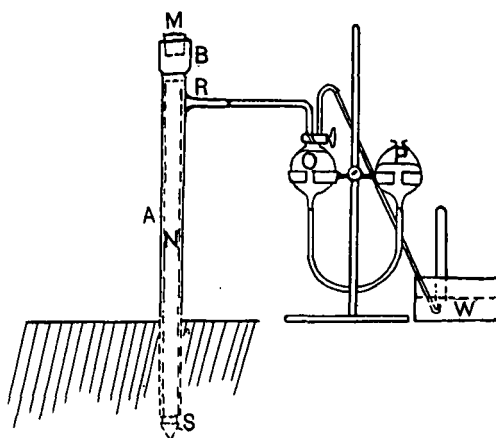

Fig. 15. Apparatus for the collection of soil air.

To obtain a sample of soil air the tube is driven vertically down into the soil to the required depth with a wooden mallet, great care being taken to prevent lateral movements. The inner rod (*N*) is then punched down about  $\frac{1}{4}$  in. and a rubber stopper (*M*) inserted in the hole at the top of the tube.

A small bulb (*O*) of approximately 30 c.c. capacity provided with a two way tap is connected to the side tube (*R*) by means of pressure tubing, and also to a small mercury reservoir (*P*); it has a delivery tube attached through which the gas is forced into a mercury trough (*W*) for collection. The flat side of the inner rod allows the gas to pass freely up the tube when the pressure in the bulb is diminished by

lowering the mercury reservoir. The first 20–30 c.c. is rejected and the next 25 c.c. is collected over mercury in thick-walled test tubes, which are then placed in small crucibles and transported in a rack to the laboratory for analysis. To prevent the rack from being blown over by winds it is held firmly in the ground by iron spikes passing through the base pieces. Only one sample is collected at each point. Successive samples vary slightly in composition (Table X) but a fairly large volume of air of tolerably uniform composition can if desired be withdrawn from the same hole.

TABLE X. *Percentage composition of successive 30 c.c. samples of soil air drawn from the same hole.*

Hole 1	CO <sub>2</sub>	O <sub>2</sub>	N <sub>2</sub>	Hole 2	CO <sub>2</sub>	O <sub>2</sub>	N <sub>2</sub>
1	0.10	20.74	79.16	1	0.36	20.36	79.28
2	0.10	20.72	79.18	2	0.45	20.46	79.09
3	0.11	20.86	79.03	3	0.39	20.55	79.06
4	0.12	20.63	79.25	4	0.36	20.54	79.10
5	0.14	20.77	79.09	5	0.36	20.57	79.07
6	0.12	20.67	79.21	6	0.36	20.45	79.19
7	0.12	20.71	79.17				
8	0.13	20.80	79.07	Hole 3			
9	0.13	20.68	79.19	1	0.18	20.62	79.20
10	0.13	20.79	79.08	2	0.18	20.74	79.08
11	0.13	20.69	79.18	3	0.15	20.63	79.22
12	0.13	20.76	79.11	4	0.15	20.74	79.61
				5	0.18	20.74	79.08
				6	0.23	20.54	79.23
				Hole 4			
				1	0.26	20.57	79.17
				2	0.25	20.49	79.26
				3	0.25	20.45	79.30
				4	0.23	20.52	79.25
				5	0.23	20.74	79.03
				6	0.21	20.63	79.36

As a rule samples of air from 8–12 holes on each plot are drawn and analysed separately, and the mean value is taken to represent fairly accurately the composition of the soil air. These mean values are given in Table VI and plotted in the various Figures 1 to 6.

Samples were drawn from all the plots on the same day so that the values are strictly comparable. The variation from place to place is fairly large, especially on the plot which has received annually 14 tons of farmyard manure, but on the unmanured plot it is comparatively narrow.



TABLE XI. *Showing variation in percentage composition of soil air taken from different holes on the same plot.*

Hole	Broadbalk (dung)			Hole	Broadbalk (unmanured)		
	CO <sub>2</sub>	O <sub>2</sub>	N <sub>2</sub>		CO <sub>2</sub>	O <sub>2</sub>	N <sub>2</sub>
1	0.39	20.63	78.98	1	0.27	20.69	79.04
2	0.32	20.66	79.02	2	0.19	20.77	79.04
3	0.25	20.76	78.99	3	0.33	20.63	79.04
4	0.37	20.69	78.94	4	0.29	20.64	79.07
5	0.34	20.70	78.96	5	0.38	20.67	78.95
6	0.32	20.69	78.99	6	0.34	20.69	78.97
7	0.41	20.53	79.06	7	0.29	21.09	78.62
8	0.40	20.54	79.06	8	0.26	21.15	78.59
Mean	0.35	20.65	79.00		0.29	20.79	78.92
Probable error of 1 determination	±0.03	±0.06			±0.03	±0.11	
Probable error of mean of all 8	±0.01	±0.02			±0.02	±0.05	

## Hoos Field Fallow, Oct. 17, 1913.

Hole	CO <sub>2</sub>	O <sub>2</sub>	N <sub>2</sub>
1	0.19	22.33	77.48
2	0.18	21.27	78.55
3	0.25	21.13	78.62
4	0.34	21.09	78.57
5	0.12	21.12	78.76
6	0.20	21.26	78.54
7	0.12	21.19	78.69
8	0.25	20.99	78.76
Mean	0.21	21.29	78.50
Probable error of 1 determination	±0.04	±0.16	
Probable error of mean of all 8	±0.02	±0.10	

It has frequently been found impossible to obtain a sample of air when the steel rod is driven into the clay subsoil and also when the surface of the ground is frozen. The soil was very wet and the pore space comparatively small, and displacement of the soil air apparently could not take place.

*Analysis of soil air.* The large type of Haldane's gas apparatus is used. The measuring tube (*A*, Fig. 16) has a capacity of 21 c.c. and is graduated from 15–21 c.c. into 0.01 c.c. The analysis of the gas is carried out under constant pressure; temperature and water vapour pressure are compensated by the bulb shown to the left. The water in the jacket must be thoroughly mixed before readings are taken: this is done by blowing through it air from foot bellows. A laboratory vessel (*B*)

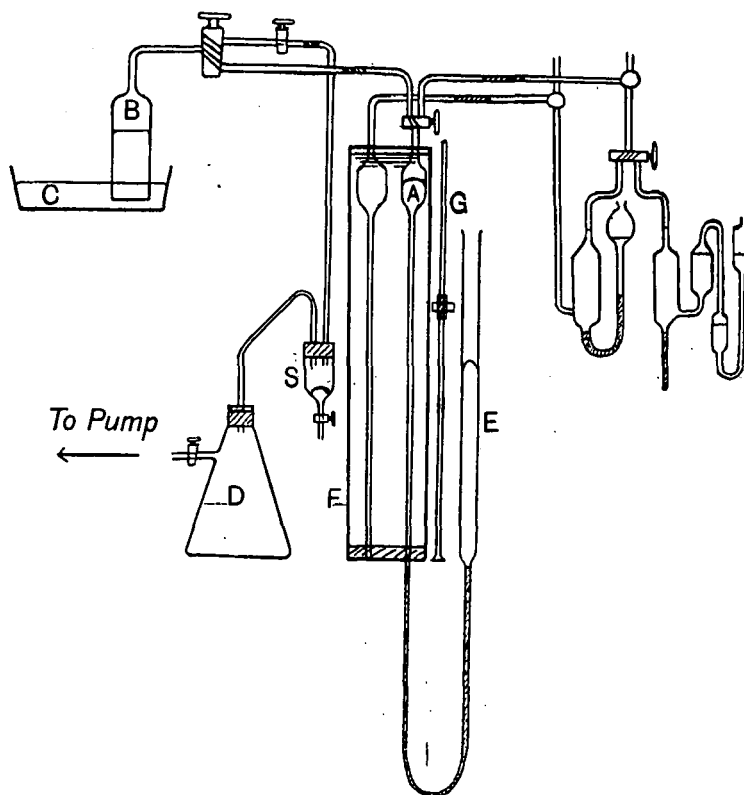

Fig. 16. Apparatus for the analysis of soil air.

in a porcelain mercury trough (*C*) [as used in the well-known Bone and Wheeler gas apparatus] is attached to the measuring tube and filled with mercury by connecting with an evacuated flask (*D*) provided with a mercury trap (*S*). Through this laboratory vessel the gas is readily introduced into the measuring tube. The analysis proceeds in the usual way. Finally the residual gas is forced by means of the levelling tube (*E*) into the laboratory vessel and ejected. A small telescope

sliding on a fixed brass rod (*G*) in front of the water jacket (*F*) which surrounds the measuring tube, and an electric light behind, enable accurate readings to be taken. The laboratory vessel also allows of analyses being made by absorption with small quantities of reagents.

*A simple apparatus for teaching purposes.* For teaching and demonstration purposes the apparatus in Fig. 17 is very useful. A piece of

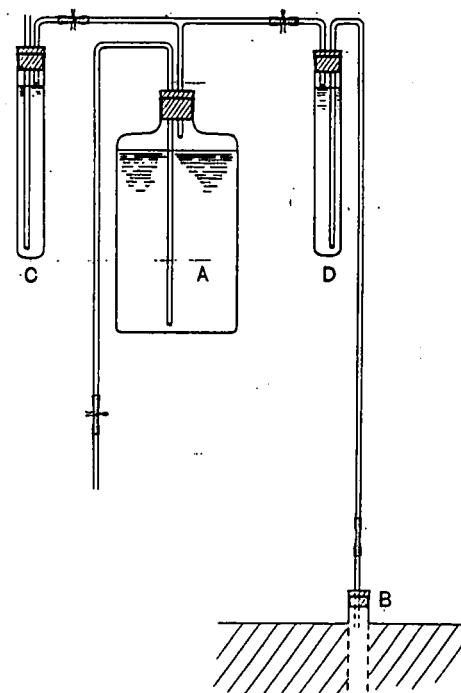

Fig. 17. Apparatus for demonstrating the pressure of  $\text{CO}_2$  in soil air.

*A*, aspirator.

*B*,  $\frac{1}{2}$ " gas pipe driven into soil.

*C*, tube of saturated baryta water open to air.

*D*, " " " " connected to soil.

half inch gas pipe is driven 6 inches into the soil and connected through a tube of baryta water to a large bottle of water fitted with a syphon tube so that it can act as an aspirator. A second tube of baryta water open to the atmosphere is also attached to the bottle. Set the aspirator going and arrange the clips so that air bubbles pass through both baryta tubes at the same rate. In a short time the one connected with the soil shows turbidity while the other open to the air is still clear.

II. *The soil of the Rothamsted fields.*

All the samples of air dealt with in this paper have been drawn from the Rothamsted fields. The soil is a heavy loam with many stones: it becomes very sticky when wet, but can be got into a good crumbly tilth as it becomes drier. Its mechanical analysis is as follows:

## Top 9 inches.

Name of fraction	Diameter of particles	Broadbalk %	Hoos Field %
Fine gravel .....	3 to 1 mm.	1.9	2.0
Coarse sand .....	1 to 0.2 mm.	6.2	6.8
Fine sand .....	0.2 to 0.04 mm.	21.4	19.5
Coarse silt .....	0.04 to 0.01 mm.	32.5	28.9
Fine silt .....	0.01 to 0.002 mm.	13.8	15.5
Clay .....	less than 0.002 mm.	17.6	18.8

The pore space and space normally occupied by air are:

Soil from	Loss on ignition, %	Specific gravity of dry soil		Volume occupied in natural state by		Volume of water		Volume of air	
		Apparent	True	Solid matter	Air and water pore space	In normal moist state	After period of drought	In normal moist state	After period of drought
Broadbalk un-manured plot	4.3	1.57	2.36	65.9	34.1	23.2	17	10.9	17.1
Broadbalk dunged plot	10	1.46	2.31	61.8	38.2	30.3	20	7.9	18.2

## SUMMARY AND CONCLUSIONS.

1. The free air in the pores of the soil to a depth of 6 inches is very similar in composition to the atmospheric air but it differs in two respects:

(a) It contains more CO<sub>2</sub> and correspondingly less oxygen, the average in 100 volumes being 0.25 volume CO<sub>2</sub> and 20.6 of oxygen against 0.03 volume CO<sub>2</sub> and 20.96 oxygen in atmospheric air.

(b) It shows greater fluctuations in composition.

Usually the sum of the CO<sub>2</sub> and oxygen is only slightly less than in atmospheric air but at periods when nitrates rapidly increase there is

a perceptible falling off of oxygen, and a still greater one in waterlogged soils.

2. Besides this free air there is another atmosphere dissolved in the water and colloids of the soils. This consists mainly of  $\text{CO}_2$  and nitrogen and has practically no oxygen.

3. The fluctuations in composition of the free soil air are mainly due to fluctuations in the rate of biochemical change in the soil, the curves being similar to those showing the amount of nitrate and the bacterial counts as far as they were taken. The rate of biochemical activity attains a maximum value in late spring and again in autumn, and minimum values in summer and winter. In autumn the bacteria increase first, then the  $\text{CO}_2$  rises, and finally the nitrate increases.

From November to May the curves closely follow those for the soil temperature which thus appears to be the dominating factor; from May to November they follow the rainfall and to a less extent the soil moisture curves. The distinct difference between rainfall and soil moisture indicates that rainfall does something more than add water to the soil. It is shown that the dissolved oxygen brought in is probably a factor of considerable importance in renewing the dissolved soil atmosphere and facilitating biochemical change.

4. Grass land usually contains more  $\text{CO}_2$  and less oxygen than arable land but we cannot attribute the difference to the crop owing to the large differences in soil composition and conditions. It is difficult to ascertain the precise effect of a crop, but as the soil differences are eliminated so the differences in composition of the soil air become less and less. No evidence could be obtained that the growing crop markedly increases the amount of  $\text{CO}_2$  in the soil air, and if it gives rise to any great evolution of  $\text{CO}_2$  in the soil it apparently exercises a corresponding depressing effect in the activities of soil bacteria. This result agrees with one obtained earlier in reference to the nitrates in the soil.

5. Such weather conditions as barometric pressure, wind velocity, variations in temperature from the mean, small rainfall, etc. seem to have but little effect on the soil atmosphere.

TABLE VI (a). *Composition of soil air (mean percentages by volume) and meteorological data.*

Date	Uncultivated land Broadbalk Wilderness						Arable land												Meteorological data				
							Broadbalk wheat						Hoos wheat and fallow						Rain-fall for 7 previous days	Mean temps for previous day	Baro. mms.	Character of previous day	
							Dunged			Unmanured			(1)			(2)							
	CO <sub>2</sub>	O <sub>2</sub>	N <sub>2</sub>	CO <sub>2</sub>	O <sub>2</sub>	N <sub>2</sub>	CO <sub>2</sub>	O <sub>2</sub>	N <sub>2</sub>	CO <sub>2</sub>	O <sub>2</sub>	N <sub>2</sub>	CO <sub>2</sub>	O <sub>2</sub>	N <sub>2</sub>	CO <sub>2</sub>	O <sub>2</sub>	N <sub>2</sub>	air	soil 6"			
1912 Dec. 19	0.55	20.35	79.10	—	—	—	—	—	—	—	—	—	—	—	—	—	—	—	—	4.4° C.	—	748.5	Showery and dull till midday; then fine and frosty at night.
1913 Jan. 24	0.28	20.40	79.32	—	—	—	—	—	—	—	—	—	—	—	—	—	—	—	—	4.4	—	748.7	Dull; snow melted by 9.0 a.m.; much milder; S. wind.
Feb. 3	0.40	20.45	79.15	—	—	—	—	—	—	—	—	—	—	—	—	—	—	—	—	4.4	—	752.2	Fair morning, sharp rains in afternoon and early evening; S.W. winds.
Feb. 11	0.40	20.17	79.43	0.55	18.97	80.48	0.13	19.86	80.01	—	—	—	—	—	—	—	—	—	—	8.3	—	766.2	Fair, bright in afternoon; S.W. winds.
Feb. 20	0.33	20.16	79.51	0.22	20.24	79.54	0.12	20.72	79.16	—	—	—	—	—	—	—	—	—	—	4.8	—	748.0	Fair till midday; little rain at noon; fair; S.E. light winds.
Mar. 7	—	—	—	0.31	20.44	79.25	0.10	20.77	79.13	—	—	—	—	—	—	—	—	—	—	10	—	763.2	Fair day, some rain with gusty winds at night.
Mar. 13	0.50	19.87	79.63	0.46	20.18	79.36	0.21	20.53	79.26	—	—	—	—	—	—	—	—	—	—	3.9	—	764.2	Fine, light S. winds.
Apr. 14	0.55	20.19	79.26	0.65	19.70	79.65	0.22	20.64	79.14	—	—	—	—	—	—	—	—	—	—	1.7	—	764.7	Fair, cold N. winds, bright sunshine at times.
Apr. 24	0.57	20.34	79.09	0.89	19.93	79.18	0.22	20.71	79.07	—	—	—	—	—	—	—	—	—	—	11.1	—	749.2	Fine, warm, light E. winds.
May 2	1.04	19.50	79.46	2.27	17.61	80.12	0.55	20.19	79.26	—	—	—	—	—	—	—	—	—	—	10	—	760	Fair generally; showery evening; fine frosty air at night; S. to S.W. winds.
May 13	1.73	18.82	79.45	1.45	19.42	79.13	0.35	20.53	79.12	—	—	—	—	—	—	—	—	—	—	10.5	11.1	756.2	Fair morning, showery from noon onwards till evening.
June 3	0.72	20.69	79.59	0.42	20.56	79.02	0.50	20.77	78.73	0.51	20.39	79.10	0.10	20.82	79.08	0.35	13.9	17.4	—	13.9	—	755.5	Fine; S. winds.
July 11	0.36	20.97	78.67	0.35	20.66	79.01	0.29	20.79	78.92	0.36	20.64	79.00	0.27	20.66	79.07	0.42	15	15.5	—	15	—	762.2	Dull; mild; thunder in S. from 1.30 to 3 p.m.; some showers; fine later.
Aug. 29	0.37	20.62	79.01	0.24	20.70	79.06	0.22	20.73	79.05	0.20	20.70	79.10	0.09	20.84	79.07	0.24	19.4	18.1	—	19.4	—	750	Fine hot morning; light N.E. wind; fine and very hot.
Sept. 22	0.46	20.57	78.97	0.17	20.79	79.04	0.11	20.83	79.06	0.26	20.80	78.94	0.05	21.01	78.94	0.52	14.4	13.3	—	14.4	—	757.2	Fine and bright; warmer N.W. wind very light; little fog at night.
Oct. 6	0.53	20.47	79.00	0.18	20.81	79.01	0.16	20.82	79.02	0.30	20.47	79.23	0.07	20.85	79.08	0.41	11.1	12.9	—	11.1	—	745	Changeable, sprinkles of rain in afternoon; S. breezes.
Oct. 17	0.70	20.50	78.80	0.34	20.43	79.23	0.16	20.72	79.12	0.38	20.61	79.01	0.21	21.30	78.49	0.47	12.2	12.0	—	12.2	—	759	Fair, light W. winds; good deal of cloud in afternoon and evening; misty at night.
Nov. 10	0.58	20.62	78.80	0.54	20.72	78.74	0.35	20.56	79.09	0.33	21.06	78.61	0.11	20.80	78.99	0.21	5.0	6.5	—	5.0	—	744.7	Fine; S. W. light airs, some rain at night.

Dec. 9	0-64	20-17	79-19	0-36	20-47	79-18	0-29	20-27	79-44	0-32	20-57	79-11	0-10	20-76	79-14	0-29	7-2	6-9	755	Dull, mild, damp at times; S. E.
Dec. 22 1914	0-63	20-19	79-28	0-34	20-45	79-21	0-25	20-35	79-40	0-17	20-44	79-39	0-04	20-68	79-28	0-13	2-8	4-5	763-5	Dull; slightly misty; E. light breezes; slight frost at night.
Jan. 20	0-32	20-55	79-13	0-32	20-51	79-17	0-14	20-62	79-24	0-10	20-92	78-98	0-16	20-88	78-96	0-09	0-5	2-4	763-5	Dull, cheerless day, cold N. E. winds; snow midday; sleet in evening.
Jan. 30	—	—	—	0-34	20-52	79-14	—	—	—	—	—	—	—	—	—	0-19	7-2	4-6	761-7	Fair, mild, light S. breezes, sprinkle of rain about 1 p.m.
Feb. 12	0-32	20-42	79-26	0-24	20-54	79-22	0-26	20-33	79-41	0-04	20-85	79-11	0-15	20-77	79-08	1-27	7-8	6-5	743-5	Dull with rain all day; heavy showers at night; S. to S. E.
Mar. 2	—	—	—	—	—	—	—	—	—	—	—	—	—	—	—	0-07	6-1	5-8	763-2	Fair day, cool W. winds; shower about 7.30 p.m.; then fair again.
Mar. 11	—	—	—	—	—	—	—	—	—	—	—	—	—	—	—	1-72	3-3	4-7	761-5	Fine morning; cold; snow; fine later; sharp white frost.
Mar. 12	0-49	19-56	79-05	0-30	20-16	79-54	0-29	20-28	79-43	0-03	20-69	79-28	0-03	20-75	79-22	2-12	3-3	4-7	744-2	Fair or fine during day; rain at night; W. winds.
Mar. 31	—	—	—	—	—	—	—	—	—	—	—	—	—	—	—	0-40	8-9	7-4	759	Showery; W. winds.
April 6	0-48	19-65	79-87	0-76	19-31	79-93	0-34	19-85	79-81	0-02	20-78	79-20	0-10	20-58	79-32	0-68	8-9	10-1	741-2	Fair during the day; heavy showers from 7 p.m. onwards; W. wind.
April 29	0-38	20-44	79-18	0-65	20-08	79-27	0-81	19-98	79-21	—	—	—	—	—	—	0-04	10	14-1	756	Fine and bright; E. airs cool at night.
May 11	0-45	20-29	79-26	0-44	20-22	79-34	0-28	20-45	79-27	0-05	20-73	79-22	0-18	20-48	79-34	0-71	6-1	9-1	752-2	Dull and cold; drizzling rain at times; W. breezes light.
May 15	0-48	—	—	0-61	—	—	0-40	—	—	0-10	—	—	0-24	—	—	0-16	12-8	14	760-7	Fine; warmer; S. W.
May 25	0-46	—	—	0-32	—	—	0-42	—	—	0-07	—	—	0-29	—	—	0-26	10	14-6	760-2	Fair generally, cold, some showers in afternoon; N. W. to N.
June 10	0-40	—	—	0-40	—	—	0-36	—	—	0-08	—	—	0-28	—	—	0-84	11-7	15-8	749	Fair morning and mild; dull later; colder continuous rain after 7 p.m.; N. W.
June 12	0-58	—	—	0-48	—	—	0-37	—	—	0-07	—	—	0-41	—	—	1-49	13-3	16-3	752-2	Fine, fresh S. to S. E. breezes till 3 p.m.; then heavy rain till 8 p.m.; N. to N. W.
June 13	0-61	20-21	79-28	0-43	20-39	79-18	0-50	19-80	79-70	0-10	20-62	79-28	0-43	19-89	79-68	1-38	17-2	16-1	753-2	Dull, misty at early morn; bright periods in afternoon; N. W. light breezes.
July 7	0-47	20-35	79-18	0-48	20-36	79-16	0-47	20-29	79-24	0-08	20-54	79-38	0-42	20-15	79-43	0-88	14-4	18	752-2	Showery at times, S. to S. W. light breezes; sharp shower about 7 p.m.
July 27	0-58	—	—	0-30	—	—	0-35	—	—	0-09	—	—	0-24	—	—	0-25	15-0	17-4	743-5	Cool; good deal of cloud; one or two showers between 2 and 4 p.m.
Sept. 12	0-32	20-50	79-18	0-24	20-61	79-15	0-24	20-54	79-22	0-04	20-72	79-24	0-13	20-70	79-17	0-32	15-0	16-2	750-5	Showery during morning, fine later, cool at night; S. wind.
Sept. 21	0-28	20-52	79-20	0-31	20-53	79-16	0-22	20-60	79-18	—	—	—	—	—	—	0-33	10	12-2	760-7	Fair generally; slight showers about noon and 6 p.m.; cold N. W. winds.

Up to Oct. 6, 1913 (1) is Hoos Wheat and (2) Hoos Fallow. After Oct. 6, 1913 (1) is Hoos Fallow and (2) Hoos Wheat. Hoos Wheat of 1913 ploughed up between Dec. 22, 1913 and Jan. 20, 1914 for the 1914 fallow.

TABLE VI (b). Moisture content, nitrate content, and bacterial numbers in soils on dates of sampling.

Date	Soil moisture per cent.				N as nitrate, parts per million				Bacterial numbers. Millions per gram						
	Broadbalk		Hoos		Broadbalk		Hoos		Broadbalk		Hoos				
	Wilderness	Dunged	Un-manured	Wheat	Fallow	Wilderness	Dunged	Un-manured	Wheat	Fallow	Wilderness	Dunged	Un-manured	Wheat	Fallow
June 3, 1913	12	11	7	11	11	6	9	3	3	7	—	—	19	9	4
July 11 "	16	11	8	9	8	7	7	6	6	18	—	—	9	6	11
Aug. 29 "	12	10	5	6	4	4	14	7	7	15	—	—	9	6	8
Sept. 22 "	17	16	13	13	12	6	17	6	6	15	26	26	4	11	12
Oct. 6 "	21	18	15	15	14	3	18	8	8	20	9	9	17	9	11
Oct. 17 "	19	20	15	16	15	5	17	7	7	3	17	24	15	7	15
Nov. 10 "	20	22	17	16	16	4	15	6	6	4	20	30	18	13	8
Nov. 22 "	—	19	16	—	—	—	13	3	3	—	—	—	—	—	—
Dec. 9 "	21	21	17	16	16	15	22	16	16	12	22	35	12	9	8
Dec. 22 "	18	21	16	16	16	9	29	20	20	11	12	30	22	9	9
Jan. 8, 1914	18	23	17	17	17	20	29	17	17	18	13	26	8	7	6
Jan. 20 "	20	27	16	16	16	18	25	18	18	16	14	25	10	14	9
Jan. 30 "	18	21	17	17	17	7	14	9	9	13	13	—	11	11	11
Feb. 12 "	20	24	16	15	17	4	19	3	3	4	—	—	—	—	—
Mar. 2 "	20	21	16	16	16	—	—	—	—	—	—	—	—	—	—
Mar. 11 "	21	22	16	6	7	7	14	7	7	7	—	—	—	—	—
Mar. 31 "	21	22	16	16	16	8	15	9	9	10	—	—	—	—	—
April 30 "	—	16	11	—	—	—	27	24	24	—	—	—	—	—	—
May 11 "	19	18	13	12	13	—	—	—	—	—	—	—	—	8	8
May 18 "	—	12	11	—	—	—	12	12	12	—	12	9	8	—	—
May 25 "	15	13	11	9	11	10	11	10	10	17	12	24	11	7	6
June 10 "	18	18	13	13	12	11	19	12	12	15	—	—	—	—	—
June 12 "	18	19	15	16	15	—	—	—	—	—	—	—	—	14	20
June 26 "	—	13	11	—	—	—	—	—	—	—	—	—	—	—	—
July 7 "	16	17	12	13	13	6	15	15	15	17	29	31	16	15	10
July 21 "	—	14	9	—	—	—	11	9	9	16	—	—	—	—	—
July 27 "	9	9	5	6	7	7	6	5	5	7	—	10	7	6	8
Aug. 13 "	—	14	11	—	—	—	6	7	7	—	—	—	—	—	—
Sept. 12 "	16	15	11	8	10	6	12	9	9	14	—	13	8	6	4
Sept. 21 "	16	16	11	—	—	4	3	8	8	—	—	16	7	—	—

Between Oct. 6 and 17 Hoos Wheat of 1913 becomes Hoos Fallow 1914.