

Implementing Orthogonal Frequency Division Multiplexing Using IFFT/FFT

Nsikan Nkordeh, Francis Idachaba, Ibinabo Bob-Manuel, Oluyinka Oni, *Members IAENG*

Abstract-Orthogonal Frequency Division Multiplexing (OFDM) is a modulation system that offers many advantages over other modulation scheme. OFDM is a particular form of Multi-carrier transmission and is suited for frequency selective channels and high data rates; it overcomes the Inter Symbol Interference (ISI) problem by modulating multiple narrow-band sub-carriers in parallel. In this paper, analysis of OFDM is carried out with emphasis on the implementation using IFFT/FFT as against multiple Oscillators and demodulators. The concept of orthogonality of carriers is used to explain the ability to transmit multi-carriers without interference and the ease of decoupling the signal information at the receivers. Matlab simulations were carried out to show these concepts

Index Term--FFT, IFFT, Modulation, Multi-carrier, OFDM, Orthogonality

I INTRODUCTION

Orthogonal Frequency Division Multiplexing (OFDM) is a techniques that involves transmitting signal information using smaller subcarriers, instead of a single large carrier. OFDM is a form of multi-carrier modulation. The basic principle of multicarrier modulation is to divide the data stream, d , into N parallel data streams with a reduced data rate of d/N ; low rate data streams are then modulated on a separate narrow band subcarriers and summed together for transmission, thereby providing the same data rate as an equivalent single large carrier system[3]. At the receiver a set of filter banks separate the wide-band signal into the original narrowband subcarriers for demodulation. In other words, OFDM involves dividing the available spectrum into several narrow sub-channels/sub carriers which experience differential flat fading as they propagate; this make equalization at the receiver end simple.

Robert W. Chang was the first person to show in 1966 theoretically the principle of operation of OFDM; he obtained a US patent on OFDM in 1970.Chang showed theoretically how to transmit simultaneous data stream through linear band limited channel without Inter Symbol Interference (ISI) and Inter Carrier Interference (ICI)

Manuscript received March 18, 2016; revised April 20, 2016.

N.S Nkordeh is a Lecturer with Department of Electrical and Information Engineering Covenant University Ota Nigeria, nsikan.nkordeh@covenantuniversity.edu.ng

F. E Idachaba an Associate Professor with Department of Electrical and Information Engineering Covenant University Ota Nigeria, francis.idachaba@covenantuniversity.edu.ng

Ibinabo Bob-Manuel is an IT consultant with Kakatar Group Nigeria Limited Abuja, ibinabo.bobmanuel@gmail.com

O. O Oni is a Lecturer with Department of Electrical and Information Engineering Covenant University Ota Nigeria, oluyinka.oni@covenantuniversity.edu.ng

The realization of OFDM was a challenge as at that time; a large number of oscillators were needed to replicate the parallel modulation and demodulation needed for its implementation. The challenge was resolved when in 1971 Weinstein and Ebert used Discrete Fourier Transform to perform baseband modulation and demodulation; this eliminated the need for oscillator banks, and made its implementable on integrated circuit possible at affordable cost. The process of moving a signal from the time domain to the frequency domain involves finding the Fourier transform, while the process of moving it from the frequency to the time domain involves the inverse Fourier transform. Orthogonality of modulating and modulated signal is an indispensable property of OFDM, and this is achieved by introducing Cyclic Prefix.

To obtain a high spectral efficiency, the frequency response of the sub- channels are made to overlap and orthogonality is completely maintained by introducing cyclic prefix; the orthogonality of OFDM overcomes the ISI problem by modulating multiple narrow-band sub-carriers in parallel. Orthogonality is a property that allows the signals to be perfectly transmitted over a common channel and detected without interference; loss of orthogonality results in blurring between the transmitted signals and loss of information[1].In OFDM, to maintain the orthogonality of the subcarrier channels, the correlation between signals transmitted on subcarriers must be zero[4] as will be mathematically shown later. The OFDM scheme has the inherited advantage over single carrier modulation techniques to mitigate ISI and frequency selectivity of the channel.

The first deployment of OFDM was in Digital Video Broadcasting (DVB) and Digital Audio Broadcasting (DAB)

II. PRINCIPLE OF OPERATION

The basic principle of OFDM is to split a high-rate data stream into a number of lower rate streams and transmit them over a number of subcarriers. Orthogonal frequency division multiplexing (OFDM) divides the base bandwidth into N orthogonal narrow sub-channels transmitted in parallel. The generation of the OFDM signals at the transmitter is accomplished using inverse fast Fourier transform (IFFT), which delivers orthogonal carriers[2] Fig1 shows the different stages involved in OFDM modulation; made up of the processes at the transmitter and the processes at the receiver.

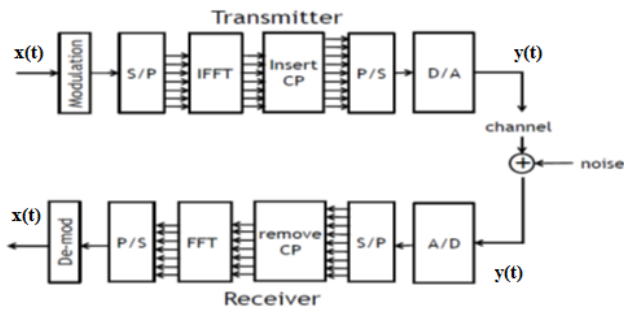

Fig.1 Stages in OFDMA process.

For two exponential signals $\psi_n(t) = e^{j2\pi f_k t}$ and $\psi_m^*(t) = e^{-j2\pi f_i t}$ that make up the sub-carrier of an OFDM system at $f_k = k/T$, these signals are defined to be orthogonal if the integral of the product of the signal over a period is zero that is ; orthogonality condition is given as

$$\int_0^T \psi_n(t) \psi_m^*(t) dt = \begin{cases} 0, & n \neq m \\ 1, & n = m \end{cases} \quad (1)$$

Or

$$\frac{1}{T} \int_0^T e^{j2\pi f_k t} e^{-j2\pi f_i t} dt =$$

$$\frac{1}{T} \int_0^T e^{j2\pi \frac{k}{T} t} e^{-j2\pi \frac{i}{T} t} dt = \frac{1}{T} \int_0^T e^{j2\pi \frac{(k-i)}{T} t} dt$$

$$= \begin{cases} 0, & \forall k = i \\ 1, & k \neq i \end{cases} \quad (2)$$

Orthogonality can also be shown for discrete signal; taking samples of equation(2) at $t = nT_s = \frac{nT}{N}$ for $n = 0, 1, 2, 3 \dots N - 1$

Taking equation (2) into discrete domain, we have

$$\frac{1}{N} \sum_{n=0}^{N-1} e^{j2\pi \frac{k}{T} nT_s} e^{-j2\pi \frac{i}{T} nT_s} = \frac{1}{N} \sum_{n=0}^{N-1} e^{j2\pi \frac{k nT}{T N}} e^{-j2\pi \frac{i nT}{T N}}$$

$$= \frac{1}{N} \sum_{n=0}^{N-1} e^{j2\pi \frac{(k-i)}{N} n} = \begin{cases} 0, & \forall k = i \\ 1, & k \neq i \end{cases} \quad (3)$$

If the available bandwidth for transmission is given by ΔW ; in an OFDM this bandwidth will be split into N

sub-channels. The information signal to be transmitted is first converted to digital bits using an Analogue-to-Digital(A/D) converter before being transmitted. The OFDM transmitter maps the information signal bits into a sequence of PSK or QAM symbols which are subsequently converted into N parallel streams. The serially modulated digital information signal are then passed through a Serial-to-Parallel(S/P) device which are converted to N parallel streams and are transmitters through different sub-carriers [5]. If $X_l[k]$ denote the l th transmit symbol at the k th carrier, $l = 0, 1, 2, \dots \infty$, $k = 0, 1, 2, 3 \dots N - 1$.

The Serial-to-Parallel conversion causes an extension in the transmission time for N symbols to NT_s which forms a single OFDM symbol with a length $T = NT_s$.

Let $\psi_{l,k}(t)$ denote the l th OFDM signal at the K th sub-carrier, which is given as:

$$\psi_{l,k}(t) = \begin{cases} e^{j2\pi f_k (t-lT)} & \forall 0 < t < T \\ 1, & \text{elsewhere} \end{cases} \quad (4)$$

According to [5], the carrier and information (baseband)OFDM signals respectively can be mathematically represented as follow in the continuous-time domain:

$$x_l(t) = Re \left\{ \frac{1}{T} \sum_{l=0}^{\infty} \left\{ \sum_{k=0}^{N-1} X_l[k] \psi_{l,k}(t) \right\} \right\} \quad (5)$$

and

$$x_l(t) = \sum_{l=0}^{\infty} \sum_{k=0}^{N-1} X_l[k] e^{j2\pi f_k (t-lT)} \quad (6)$$

If equation(5) is sampled at $t = lT + nT_s$ with $T_s = T/N$ and $f_k = k/T$, the corresponding discrete-time OFDM is

$$x_l[n] = \sum_{k=0}^{N-1} X_l[k] e^{j2\pi k n / N} \quad \forall n = 0, 1, \dots, N - 1 \quad (7)$$

A closer look at equation (7) reveals that the process of OFDM modulation is effectively an N-point Inverse Direct Fourier Transform IDFT, and this can be efficiently computed using the IFFT (Inverse Fast Fourier Transform) algorithm.

At the receiver where demodulation takes place, the transmitted signal $X_l[k]$ can be decoupled from the receive OFDM,

$$y_l(t) = \sum_{k=0}^{N-1} X_l[k] e^{j2\pi f_k (t-lT)} \quad (lT < t < lT + nT_s)$$

y exploiting the orthogonality among the sub-carriers as stated in Equation(2) , as follow:

$$\begin{aligned}
 Y_i[k] &= \frac{1}{T} \int_{-\infty}^{\infty} y_i(t) e^{-j2\pi k f_k (t-lT)} dt \\
 &= \frac{1}{T} \int_{-\infty}^{\infty} \left\{ \sum_{i=0}^{N-1} X_i[i] e^{-j2\pi i f_k (t-lT)} \right\} e^{-j2\pi k f_k (t-lT)} dt \\
 &= \sum_{i=0}^{N-1} X_i[i] \left\{ \frac{1}{T} \int_0^T e^{-j2\pi (f_i - f_k)(t-lT)} dt \right\} = X_i[k] \quad (8)
 \end{aligned}$$

The sampled discrete time representation OFDM signal, $y_i(t)$ at $t = lN + nT_s$ is given as

$$\begin{aligned}
 Y_i[k] &= \sum_{n=0}^{N-1} y_i[n] e^{-\frac{j2\pi kn}{N}} \\
 &= \sum_{n=0}^{N-1} \left\{ \frac{1}{N} \sum_{i=0}^{N-1} X_i[i] e^{j2\pi in/N} \right\} e^{-j2\pi kn/N} \\
 \sum_{n=0}^{N-1} \sum_{i=0}^{N-1} X_i[i] e^{j2\pi (i-k)n/N} &= X_i[k] \quad (9)
 \end{aligned}$$

The left hand side of equation (9) computes the N-point DFT of $y_i[n]$ (for $n = 0, 1, 2, \dots, N-1$); this can be efficiently computed using the FFT (Fast Fourier Transform) algorithm

Equations (8) and (9) show that OFDM process can be wholly implemented digitally by employing an IFFT (Inverse Fast Fourier Transform) algorithm at the transmitter and a FFT (Fast Fourier Transform) algorithm at the receiver, as a second method of implementation. In the first method, multiple oscillators are needed at the transmitter end, while at the receiver many coherently matched demodulators are required. The complexity of the oscillators and demodulator increases as the number of sub-carriers increase. The implementation of OFDM through the use of IFFT/FFT algorithm greatly reduces the cost, size of the system and complexity; the IFFT/FFT has the computational capability to handle as many sub-carriers as possible.

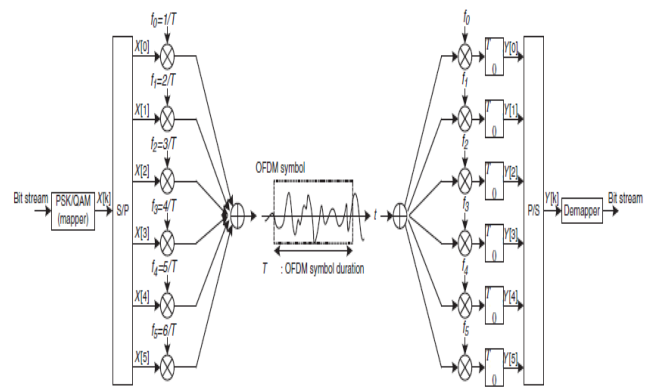

Fig 2 Modulation and demodulation in OFDM

Fig 2 illustrates OFDM modulation and demodulation; at the transmitter, the frequency domain symbols $X[k]$ modulate the sub-carriers with a frequency of $f_k = k/T$ for $N = 6 (k = 0, 1, 2 \dots 5)$, while at the receiver the frequency domain symbol is recovered from the sub-carrier frequency by employing the orthogonality property of the sub-carriers.

III. SIMULATIONS AND RESULTS.

The simulation was done using Matlab ; a realization of what takes place at the transmitter(modulator)and receiver (demodulator) was carried out.OFDM is the modulation standard, and OFDMA the access method for both WiMAX and LTE.The simulation was carried out for WiMAX 2.5GHz, of channel bandwidth 10MHz and OFDM FFT size of 8192.

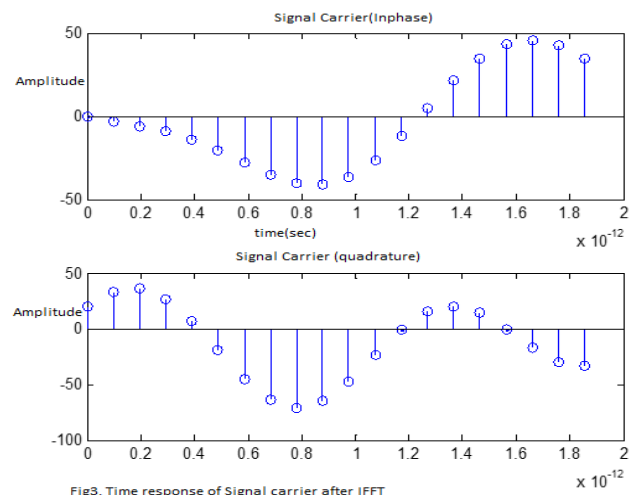

Fig.3 Time response of signal carrier after IFFT

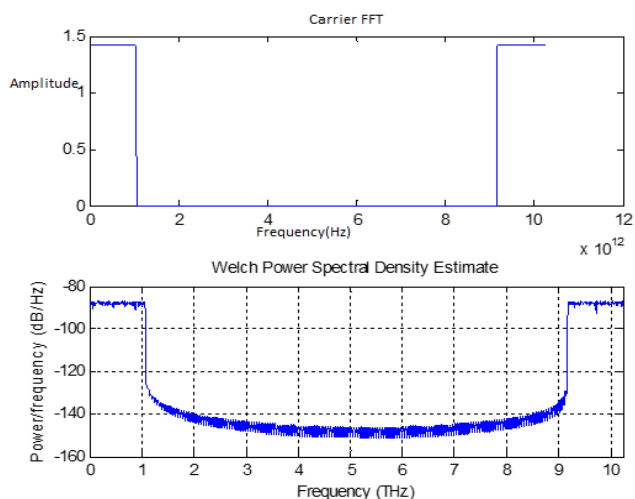

Fig.4 Frequency Response of Signal Carrier after IFFT

Fig.4 Frequency response of signal carrier IFFT

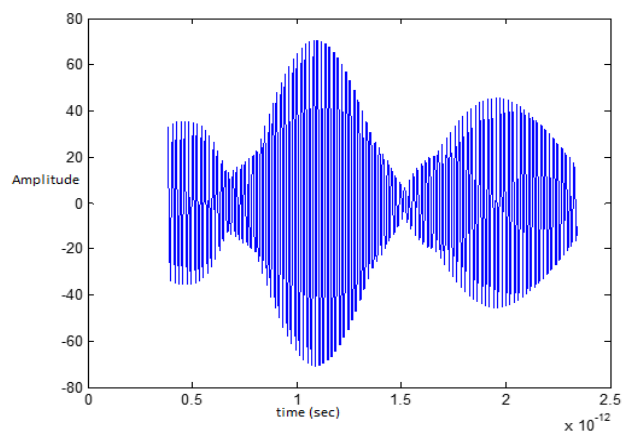

Fig.5 Time response of information Signal

Fig.5 Time response of informal signal

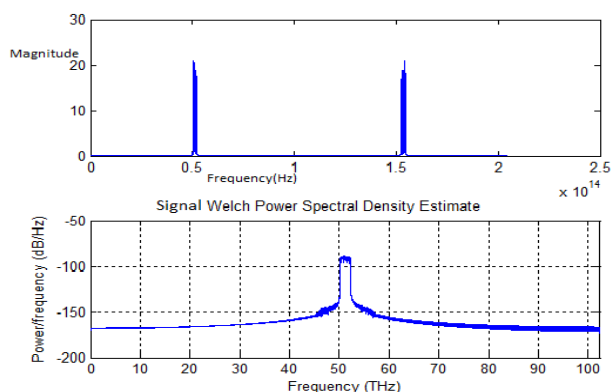

Fig. 6 Frequency response of Signal Information

Fig.6 Frequency response of information signal

IV. CONCLUSION

OFDMA is becoming increasingly popular in the telecoms and Signal processing industries because of the inherent capacity increase it offers. From the analysis in this paper, it

has been shown that by mathematical analysis and MATLAB simulation that OFDM helps in 'compressing' many orthogonal signals into one main carrier; thereby increasing transmission bandwidth. The graphs shows the process through which IFFT/FFT is used in realizing OFDM.

REFERENCES

- [1] Ramjee Prasad and Fernando J. Velez, WiMAX Networks @ Springer Science
- [2] Ramjee Prasad and Fernando J. Velez, WiMAX Networks @ Springer Science
- [3] Ali Ramadan Ali, Tariq Jamil Khanzada, and Abbas Omar "Frequency Offset Compensation for OFDM Systems Using a Combined Autocorrelation and Wiener Filtering Scheme"
- [4] Gavin Hill "Peak Power reduction in OFDM Transmitter", Phd Thesis to Victoria University of Technology, School and Communication and Informatics 2011
- [5] Muhammad Shahid "Modelling, simulation and performance analysis of Multi-carrier TimeDelay Diversity Modulation" Phd Thesis to Naval Postgraduate School Monterey, California 2005
- [6] Yong Soo Cho, Jaekwon Kim, Won Young Yang, Chung G. Kang "MIMO-OFDM Wireless Communication with MATLAB" IEEE Press, John Wiley & Sons (Asia) Pte Ltd
- [7] Leonard J. Cimini, Jr Ye (Geoffrey) Li "Orthogonal Frequency Division Multiplexing For Wireless Channels" AT&T LABS - RESEARCH
- [8] Nilesh Chide, ShreyasDeshmukh, P.B. Borole "Implementation of OFDM System using IFFT and FFT" International Journal of Engineering Research and Applications (IJERA) ISSN: 2248-9622 www.ijera.com Vol. 3, Issue 1, January -February 2013, pp.2009-2014
- [9] Kh. Tovmasyan "OFDM signal constellation processing on Radar applications" Armenian Journal of Physics, 2013, vol. 6, issue 4, pp. 204-208
- [10] Yigal Leiba "OFDMA Tutorial - Theory, principles, design considerations and applications" Runcom Technologies, Ltd., Rishon-Lezion, Israel
- [11] Keithly "Advanced Measurement Techniques for OFDM- and MIMO-based Radio Systems: Demystifying WLAN and WiMAX Testing, 1st edition
- [12] Maneesha Sharma "Effective channel state information (CSI) feedback for MIMO Systems in Wireless Broadband communication" M.Eng Thesis to School of Electrical Engineering and Computer Science and Engineering Faculty, Queensland University of Technology
- [13] Diversity-Multiplexing Tradeoff: A Comprehensive View of Multiple Antenna Systems by Lizhong Zheng
- [14] Characterization of MIMO Antennas with Multiplexing Efficiency by Ruiyuan Tian, BuonKiong Lau, and Zhinong Ying ; Electromagnetic Theory Department of Electrical and Information Technology Lund University Sweden
- [15] On the Diversity, Multiplexing, and Array Gain Tradeoff in MIMO Channels Luis G. Ordóñez, Daniel P. Palomar, and Javier R. Fonollosa SIT 2010, Austin, Texas, U.S.A., June 13 - 18, 2010
- [16] Franco A.T.B N Monteiro , Lattices in MIMO Spatial Multiplexing: Detection and Geometry
- [17] J.G Proakis. Digital Communications, McGraw Hill 4th Edition
- [18] Jr G. D. Forney and G. Ungerboeck. Modulation and coding for linear gaussian channels. *IEEE Trans. Info. Theory*, 1998.
- [19] Vinayak Nagpal Cooperative multiplexing in Wireless Relay Network
- [20] Francisco A.T.B.N Monteiro, "Lattices in MIMO Spatial Multiplexing: Detection and Geometry"
- [21] Luis G. Ordóñez, Daniel P. Palomar and Javier R. Fonollosa "On the Diversity, Multiplexing and Array Gain Tradeoff in MIMO Channels"
- [22] Hiroshi Nishimoto, "Studies on MIMO spatial multiplexing for high-speed communication", Phd dissertation to Hokkaido University, 2007
- [23] Diversity-Multiplexing Tradeoff: A Comprehensive View of Multiple Antenna Systems by Lizhong Zheng
- [24] Characterization of MIMO Antennas with Multiplexing Efficiency by Ruiyuan Tian, BuonKiong Lau, and Zhinong Ying ; Electromagnetic Theory Department of Electrical and Information Technology Lund University Sweden

- [25] On the Diversity, Multiplexing, and Array Gain Tradeoff in MIMO Channels Luis G. Ordonez, Daniel P. Palomar, and Javier R. Fonollosa SIT 2010, Austin, Texas, U.S.A., June 13 - 18, 2010
- [26] Franco A.T.B N Monteiro, Lattices in MIMO Spatial Multiplexing: Detection and Geometry
- [27] J.G Proakis. Digital Communications, McGraw Hill 4th Edition