

## ANALYSIS OF VARIOUS FACTORS IN ORDER TO ENHANCE PRODUCTIVITY AND INCOME OF DAIRY CATTLE FARMERS IN CENTRAL JAVA - INDONESIA

**Mukson, Isbandi, S.I. Santosa, Sudjadmogo and A. Setiadi**

*Faculty of Animal Science and Agriculture, Diponegoro University,*

*Tembalang Campus, Semarang 50275 - Indonesia*

*Corresponding E-mail : mukson.fapetundip@gmail.com*

*Received June 12, 2012; Accepted August 28, 2012*

### ABSTRAK

Penelitian bertujuan untuk menentukan potensi pengembangan sapi perah rakyat dan pengaruh berbagai faktor usaha untuk peningkatan produktivitas usaha dan pendapatan peternak sapi perah. Penelitian menggunakan metode survei pada tiga lokasi, yaitu Kabupaten Semarang, Boyolali dan Banyumas. Sampel sebanyak 495 peternak, terdiri dari 225 peternak anggota Koperasi Unit Desa (PKUD), 180 peternak anggota koperasi susu (PKSU) dan 90 peternak anggota gabungan kelompok tani ternak sapi perah (PGPT) sebagai responden penelitian. Data primer diperoleh melalui wawancara dengan peternak dan data sekunder diambil dari instansi yang terkait. Analisis deskriptif dan model SEM (structural equation modeling) digunakan dalam penelitian. Berdasarkan analisis LQ (Location Quotient), sapi perah di Jawa Tengah potensial untuk dikembangkan. Nilai LQ Kabupaten Semarang, Boyolali dan Banyumas berturut-turut adalah 4,57; 7,68 dan 0,46 dengan rata-rata 4,24. Tingkat pendapatan peternak sebesar Rp 1.024.095/bulan dengan rata-rata skala kepemilikan 2,7 ekor sapi laktasi/peternak. Model SEM dihasilkan sesuai dengan persyaratan. Faktor usaha yang berpengaruh langsung dan sangat signifikan ( $P < 0,01$ ) terhadap produktivitas usaha adalah faktor lingkungan, ekonomi, kelembagaan dan sosial. Sedangkan terhadap pendapatan peternak faktor teknis dan kelembagaan berpengaruh sangat nyata ( $P < 0,01$ ) dan faktor lingkungan, ekonomi dan sosial berpengaruh nyata ( $P < 0,05$ ) terhadap pendapatan peternak. Hasil ini menunjukkan bahwa peran faktor teknis, sosial, ekonomi, kelembagaan dan lingkungan usaha perlu diperhatikan dalam upaya untuk peningkatan produktivitas usaha dan pendapatan peternak.

*Kata kunci : faktor produktivitas, pendapatan, sapi perah*

### ABSTRACT

This survey aims were to determine the potency of dairy cattle development, and to find the relationship among of various factors to improve productivity and income of dairy cattle farmers. Semarang, Boyolali and Banyumas districts were taken as study location. Total respondents were 495 farmers, in which 225 farmers were members of the Village Unit Cooperative (VUC), 180 farmers were member of Various Business Cooperative (VBC) and 90 farmers were member of Farmer Group Association (FGA). Primary data were obtained through interviews with farmers and secondary data were obtained from related institution. Descriptive and Structural Equation Modelling (SEM) analysis were used in the study. Based on LQ (Location Quotients) analysis, dairy cattle in Central Java was potential to be developed. The LQ value of Semarang, Boyolali and Banyumas districts were 4.57, 7.68 and 0.46, respectively, with 4.24 on average. The dairy cattle farmer income was IDR 1.024.095/month with an average of scale ownership lactation cattle was 2.7 head/farmer. Model Goodness of Fit of SEM was fit with the SEM requirement. The productivity was influenced significantly ( $P < 0.01$ ) by environmental, economic, institutional, and social factors. Dairy cattle farmer income were influenced highly significant ( $P < 0.01$ ) by technical and institutional factors ( $P < 0.05$ ) of the income. These results indicated that the role of technical factors, social, economic, institutional and business environment needs to be considered in order to increase business productivity and farmer incomes.

*Keywords : productivity factor, income, dairy cattle*

## INTRODUCTION

The dairy business plays an important role to rotate the economic in rural area. Dairy cattle farmers raised 2-3 head on average. Usually the business just as additional job beside their main job as food plant farmer. In Central Java, dairy cattle produce 6-10 liters/ head/day (Mukson *et al.*, 2010; Yulianto, 2011).

The income of the dairy cattle farmer generated from the dairy cattle business is still relatively slow. This condition is caused by various factors both internal and external such as technical, economic and environment factors. The productivity of businesses is also low. Based on this condition, dairy farm businesses are necessary to improve in order to increase the income of the farmers.

Dairy business in Indonesia is still dominated by small-scale farmer. The supply of milk from farmers were low and still not meet the demand of Milk Processing Industry (MPI) yet. Indonesia government has imposed dairy industry revitalization program until the year 2014. The purpose of policy to increase the production and productivity of dairy cows. Other programs which also support the dairy cattle development was a Presidential Regulation. No. 28, 2008 regarding the National Industrial Policy which emphasizes an increase in livestock productivity, population and ownership of dairy cattle, milk quality, feed quality improvement, human resources improvement, cooperative partnership with MPI, increase the access of capital and increase milk consumption.

Up to now the national milk production supply 25-30% and the remaining 70% was supplied by milk imports (Firman, 2010). Usually Indonesia imported milk from Australia and New Zealand in form of raw milk or as an processed product ("finished product"). The low production and productivity of the domestic milk farmer are caused by lack of capital, small cattle owned by farmer, limited feed both the quality and quantity, and the limited handling post-harvest and marketing of products (Firman, 2010; Mukson *et al.*, 2010). This dairy cattle businesses is influenced by various aspects such as technical, social, economic, and institutional, and environment factors that has not been widely recognized by farmers and other businesses. Situation of the dairy cattle business is affected by the low investment, productivity, efficiency, revenue, and business competitiveness. In order to

improve the dairy cattle business, comprehensive manner is needed, especially on the role of various factors relating to technical business (business management), social and human resources, economic, institutional and business environment. The research was conducted to determine the various factors that influence the productivity and incomes of dairy cattle farmers in Central Java.

## MATERIALS AND METHODS

Three districts in Central Java, namely Semarang, Boyolali and Banyumas regency were chosen as the study location. The study was held in September 2011 to January 2012. The locations were chosen by purposive sampling, which based on consideration of a production center for the dairy cattle and as milk marketing channels in Central Java. The respondents interviewed in this study based on Village Unit Cooperative (VUC), Various Business Cooperative (VBC), and Dairy cattle farmer Group Association (FGA). Five (5) cooperatives and one (1) FGA were taken in Semarang regency, three cooperatives were taken in Boyolali regency and one (1) cooperative was taken Banyumas regency. The sample farmers were taken followed the formula (Lemeshow and David, 1997):

$$n=(4.pq)/d^2$$

where: n = sample size, p = proportion of farmers who have cattle lactation, q = the proportion of cattle farmers who do not have lactation and d = the limit of error (absolute precision).

Four hundred ninety five (495) farmers were interviewed in this study composed of 225 farmers were member of VUC, 180 farmers of VBC and 90 farmers were member of FGA. Primary data was collected by questionnaire-based interview technique, the questioner include the identity of respondents, the dairy business conditions, human resources condition, aspects of milk production, and technical factors, social, economic, institutional and business environment of dairy cattle. While the secondary data were taken from related institution, such as the Animal Husbandry Department and the Central Bureau of Statistics.

Data analysis was performed by descriptive and statistical analysis. Descriptive analysis was used to describe the condition of the dairy cattle business. Analysis of business factors and indicators of measurement using a Likert scale model of the five categories: (Very Poor = 1, Poor

= 2, Fair = 3, Good =4 and Very Good = 5) as described by Indriantoro and Supomo (2002). Structural Equation Model (SEM) were used to determine the direct or indirect effect of various factors on the productivity of the dairy business, and incomes of farmers. AMOS version 16 was used. The fit of model were indicated by Chi-Square as small as possible, the probability ( $\geq 0.05$ ), RMSEA (The Root Mean Square Error Approximation,  $\leq 0.08$ ), TLI (Tucker Lewis Index,  $\geq 0.90$ ) and AGF (Adjusted Goodness of Fit Index,  $\geq 0.90$ ) (Ghozali, 2007; Wijaya, 2009).

## RESULTS AND DISCUSSION

### Business Overview Dairy Cattle in Central Java

Central Java is one of the provinces in Indonesia which has the largest population of dairy cows, number two after East Java. Dairy cow population in Central Java in the year 2010 was 122,489 heads and produce 100,149,736 liters of milk production a year (Central Java, Animal Husbandry and Animal Health Department, 2011a). East Java province has a population of 231,408 head of dairy cattle and produced 528,100.00 liter of milk. West Java Province has 120,475 head of dairy cattle population, with a total of milk production was 262,177,000 liters (Directorate General of Animal Husbandry and Animal Health, 2011).

The dairy cattle in the Central Java region spreads covering producer districts, starting from the city of Semarang, Semarang regency, Salatiga, Boyolali, Klaten, Karanganyar and Sukoharjo and Temanggung, Magelang, Wonosobo and Banyumas districts. Boyolali regency have the biggest number of dairy cattle. The dairy cattle population in Boyolali were 62,480 heads (51.08%) and the dairy cattle population in Semarang District were 37,999 heads (31.02%) of the total population of dairy cows in Central Java. The number of dairy farmers in Central Java were 49,256 households with total number of cattle were 122,489 heads. The average of ownership were 2.49 head/household. Grass production able to support 1,671,961 AU dairy cattle, the field grass able to support 1,092,711 AU of dairy cattle, and agricultural by product like rice straw able to support 2,700,242 AU dairy cattle. Banyumas, Semarang and Boyolali area were suitable to develop dairy cattle business, because of their temperature and environment. Semarang district has a range temperature of 26.2°C-28.5°C while

Boyolali and Banyumas has average temperature of 26.3°C on average. According Sudono *et al.* (2003) that temperature for achieving optimal productivity is 23-28°C. Toharmat (2010) reported that the productivity of dairy cows is strongly influenced by environmental conditions, especially temperature and humidity.

The growth rate of dairy cattle population was positive even still relatively low. Growth rate of dairy cattle was 1.56% on average, This condition indicates that the growth of the dairy business in Central Java continues to grow, even not optimal yet. Effort to increase the dairy cattle population is needed to meet the milk demand in Central Java.

### Analysis of Potential Development in Dairy Cattle Research Sites

The growth rate of dairy cattle population in the study from 2006 to 2010 is shown in Tabel 1. The highest growth rate was reached by Semarang District (3.97%), then Boyolali was (1.16%), whereas Banyumas was decreased (-8.21%). The LQ (location Quotients) analysis was to determine the basic of the dairy sector, which showed that the average value of LQ in District of Semarang, Boyolali and Banyumas were 4.57; 7.68 and 0.46 respectively, average of LQ in three districts was 4.23. These results indicated that Boyolali and Semarang were potential and Banyumas was less potential. The number of dairy cattle population and LQ value analysis are presented in Table 1.

According to Arsyad (1999) and Hendarto (2000), an area could be said as basis when the value of  $LQ > 1$ . As shown in Table 1. the trend of LQ value has decreased, these results demonstrate the growth of dairy cows at three study location was steady and grew slowly. These conditions indicated the resources has not been used optimally, especially supporting resources both technical, social, economic, institutional and business environment. The results of Mukson *et al.* (2011) showed that the LQ based on indicators of the dairy cattle population in the middle lane was more potential than that in the South line (4.93 vs. 0.15). It was necessary to have a stronger effort in order to increase the dairy cattle population.

### Household Characteristics of Dairy Cattle Farmers

Household characteristics of dairy cattle farmers were measured based on the criteria for

Table 1. Dairy Cattle Population and LQ Value in Semarang, Boyolali and Banyumas Regency

Year	Dairy Cattle Population Year (head)			
	Semarang	Boyolali	Banyumas	Average
2006	32,456 (4.54)	59,687 (8.47)	1,637 (0.42)	(4.47)
2007	33,467 (4.96)	59,687 (7.48)	1,509 (0.60)	(4.35)
2008	34,067 (4.39)	61,749 (7.36)	1,104 (0.41)	(4.15)
2009	35,451 (4.52)	62,038 (7.46)	1,115 (0.42)	(4.13)
2010	37,999 (4.46)	62,480 (7.62)	1,124 (0.42)	(4.16)
r (%)	3.97 (4.57)	1.16 (7.68)	-8.21 (0.46)	(4.24)
Trend analysis of LQ	Y=4.75-0.06	Y=8.19-0.17	Y=0.53-0.02	Y=4.50-0.08

Source: Animal Husbandry Statistics (2011); ( ) = The value of LQ

age, education, family size, the main work and business experience. The results showed that most dairy cattle farmers were member of VCU, member of VBC, and member of FGA who still in the productive age, the age of farmers was 25-50 years (72.12%), while the remaining age above 50 years (27.88%) old. Productive age was expected to develop the business more optimal.

Most of farmer education was graduated from Elementary School (56.67%), from Junior High School was 21.01%, Senior High School 19.60%, and college was 2.63%). Low education background were common in agricultural sector include dairy cattle. Efforts to increase knowledge and skills of the farmer in dairy cattle business, such as non-formal education was needed.

The extension services such as counseling and direct technical assistance would improve business productivity. The result showed the highest number of household members were 4-5 people (52.93%), and household with 1-3 member was 44.85%, and the remaining household with more than 5 members was 2.22%. In dairy cattle farmers household, the member were required as a source of labor, the dairy cattle business activities, labor was carried out from the household member. Most of the respondents work as rice farmers as main job (78%). Biggest number of businesses experience with the range of 5-15 years, was 54.95% less than 5 years was 19.39% and above 15 years was 25.66%. The experience was expected to improve skills on dairy business management, so it would increase the dairy cattle farmer income.

### Profile of Dairy Cattle Farmers and Business Productivity

Dairy cattle business profile in this study showed the farmers have 3-4 head was 35.55%, farmers own 5-6 heads was 24.85%, farmers own 7-10 heads was 22.02%, and and farmers own over 10 heads was 4.85%, while farmers own 1-2 heads was 12.73%. Based on scale of cattle owned by farmers was still low. This result of the study in agreement with Yulianto (2011), that stated the scale of the cattle owned by farmers only were 3-4 heads.

Based on the ratio of lactating dairy cows and non-lactating dairy cattle, the ratio above 60% was still relatively small, was only 28.69%, while the remaining of 71.31% was the ratio below 60%. According to Sudono *et al.* (2003), noted to keep producing milk, the ratio should be maintained between lactating and non lactating cattle, at least should be 60%. Service per conception (S/C) is the one of productivity measurement. The result of the study showed that dairy cattle need 1-2 times service before pregnant was 62%, and dairy cattle need more than 2 times service before pregnant was 37.37%. The average milk production of the respondents were of 9.2 liters/cow/day. The majority of respondents (53.74%) own cattle which produce milk 6-10 liters/head/day, 23.64% respondents own cattle which produce 11-15 liters/head/day, 4.85% respondents own cattle which produce more than 15 liters/head/day and 17.78% respondents own cattle which produce 3-5 liters/head/day. Milk production of dairy cattle owned

by farmers of VBC member was 10.25 liters/head/day, whereas the dairy farmer members of cooperatives and members of FGA were relatively low, amounting to 8.68 and 8.58 liters/head/day, respectively (Table 2).

Milk were produced by dairy cattle per head was still relatively low compare with the expected target with the revitalization of the dairy cattle program. Dairy cattle is expected can produce milk at least 15 liters/head/day. The result of study still showed almost 36.0% of dairy cattle produces 5.4 liters/head/day, so the effort to increase the productivity was needed. According to Prasetyo *et al.* (2005) and Firman (2010) there were several factors influence the low milk production, namely: 1) not efficient for low-scale ownership, and generally as a sideline business, 2) the price of milk at farm level was lower compared with production costs, 3) the farmer has not conducted proper in milk handling, and 4) low access to capital. To improve that condition dairy

revitalization program needs to be done through 1) human resources and institutional development, 2) the dairy cattle population enhancement, 3) animal health services improvement, 4) facilities processing equipment improvement, 5) marketing facilities development, 6) facilities feed development, 7) The information systems application and 8) Advocacy and promotion improvement (Department of Animal Husbandry and Animal Health (DHAH) of Central Java Province, 2010b). Results of dairy productivity and incomes of farmers can be seen in Table 2. Milk prices largely reflect the quality of milk (59.60%) in the range of IDR 2,700-2,900/liters (Table 2). This price also reflects the farmers do not get a good price as they expected. Dairy cattle farmers earn an average income of IDR 819,276/month on average. Based on the income of farmers member of VUC was IDR 712,296/month on average, the income dairy cattle farmers member of VBC was IDR

Table 2. Productivity of Milk and Dairy Cattle Income Farmers

No.	Differences	Average	Tukey HSD Test Descriptions		
			VUC-VBC (Sign.)	VBC-FGA (Sign.)	VUC-FGA (Sign.)
1.	Productivity Milk (liters/head/day)				
	-VUC	8.58	0.000**)		
	-VBC	10.25		0.010**)	
	-FGA	8.68			0.978 <sup>ns</sup>
	Total	9.20			
2.	Price of Milk(IDR/liter)				
	-VUC	2,874	0.000**)		
	-VBC	2,823		0.811 <sup>ns</sup>	
	-FGA	2,813			0.000**)
	Total	2,844			
3.	Income of Farmers (IDR/month)				
	-VUC	712,296	0.000**)		
	-VBC	1,004,700		0.001**)	
	-FGA	715,866			0.999 <sup>ns</sup>
	Total	819,276			

VUC = Farmers member of Village Unit Cooperative; VBC = Farmers member of various business Cooperative; FGA = Farmers members of Farmer Group Association; Regional Minimum Wage of Central Java = IDR 874,166 (average of 3 districts)

Table 3. Effect of Various Factors Against Dairy Business Productivity Enterprises and Revenue of Dairy Cattle Farmer

No.	Business factors	Estimate	S.E.	C.R.	P
1.	SF ← EnF	0.522	0.051	10.222	***
2.	TF ← EnF	-0.025	0.048	-0.597	0.597
3.	EF ← EnF	-0.046	0.043	-1.054	0.292
4.	EF ← TF	0.062	0.037	1.669	0.095
5.	EF ← SF	0.218	0.035	6.257	***
6.	IF ← SF	0.289	0.053	5.439	***
7.	IF ← TF	-0.182	0.055	-3.300	***
8.	IF ← EF	0.806	0.067	12.102	***
9.	IF ← EnF	0.107	0.064	1.674	0.094
10.	PrF ← EnF	0.396	0.045	8.760	***
11.	PrF ← TF	-0.036	0.039	-0.922	0.357
12.	PrF ← EF	-0.142	0.054	-2.649	0.008
13.	PrF ← IF	0.229	0.032	7.139	***
14.	PrF ← SF	0.194	0.039	5.003	***
15.	FPN ← EnF	0.095	0.045	2.120	0.034
16.	InF ← TF	-0.162	0.036	-4.474	***
17.	InF ← EF	0.118	0.050	2.365	0.018
18.	InF ← PrF	0.046	0.042	1.114	0.265
19.	InF ← IF	0.204	0.031	6.596	***
20.	InF ← SF	0.077	0.036	2.100	0.036

TF: Technical factor; SF: Social Factor; EF: Economic Factor; IF: Institutional Factor; EnF: Environmental Factor; PrF : Productivity Factor; InF : Income Factor

1,004,700 on average and the income of farmers member of FGA was IDR 715,866 on average (Table 2). Revenues from other products came from milk and the calf sold were estimated on average by 25% (IDR 204,819) obtained income of IDR 1,024,095,-/month, which means dairy cattle farmer income was greater than minimum regional salary (*Upah Minimum Regional/UMR*) Central Java in 2012, the income of the dairy farmers of 3 districts was IDR 874,166 on average.

Dairy farm businesses conducted by farmers generated a lot of advantages. According to Sudono *et al.* (2003), the advantages were: 1) the

dairy farm enterprise is a business that still being able to produce milk every day, 2) very efficient in turning food into protein and calories, 3) produce a fixed income, 4) produce fertilizer and 5) absorption working families, then reduce unemployment.

#### **Analysis of Various Factors Influence Business Model Dairy Farmers Against Productivity and Income**

Model of the influence of various factors dairy businesses to see how the influence of various factors such as business technical factors (TF), social factors (SF), economic factors (EF),

Table 4. Model Goodness of Fit of the Model

Index	Cut off Value	Result	Evaluation Model
Chi-Square	Close to 0 (minimum)	0.001	Good
Probability	$\geq 0.05$	0.982	Good
RMSEA	$\leq 0.08$	0.00	Good
TLI	$\geq 0.90$	1.00	Good
AGFI	$\geq 0.90$	1.00	Good

RMSEA : Root Mean Square Error Approximation; TLI : Tucker Lewis Index; AGFI: Adjusted Goodness of Fit Index

institutional factors (IF) and environmental factors (EF), to factor productivity (PrF) and the factor income of farmers (InF). The results of the analysis using the SEM are presented in Table 3.

As shown as in Table 3, environmental factors, economic, institutional, and social factors influence directly and highly significant ( $P < 0.01$ ) on the productivity, while technical factors and institutional factors influence indirectly the productivity. These results indicate that the management of the business factors must be improved to achieve high productivity. Institutional, technical factors influence directly and high significant to the income of dairy cattle farmers. Economic and social factors significantly affect ( $P < 0.05$ ) the income. The result showed that the productivity factor is not significantly influence ( $P > 0.05$ ) the income of farmers. This is probably the dairy business is still a sideline business and small-scale ownership. Indirect effect for productivity is the environmental factors would influence Social factors, then would influence productivity. Socio economic and institutional factors would influence the productivity. Indirect factor income institutional factor for income were technical factors would influence institutional factors then would influence income factors. economic factors would influence institutional factors and finally the improvement of all factors would improve the farmers income, institutional and environment needs to be considered in efforts to increase business productivity and farmer incomes.

Research done by Thau (2004), Suzuki *et al.* (2005) and Mukson *et al.* (2010) suggested that social factors, economic, institutional, environmental and family resources affect the productivity and development of the dairy business. In the dairy business development

efforts of the people still need to be done, given the limitations of the various internal and external resources. In agreement with the results of research by Purwanto and Nuraeni (2006) which found that the factor of human resources, natural resources and other supporting factors affect the development of dairy cows. The resulting SEM Model Goodness of Fit Indices were fit with SEM requirement (Table 4), and the business model of the influence of various factors on productivity and incomes of farmers are presented in Figure 1. That figure showed some factors would influence the productivity, namely: 1) environment factor, 2) economic factor, 3) institutional factor, and 4) social factor, while environment factor, technical factor, economic factor, institution factor and social factor influence the income. The indirect effect which influence the productivity and income of the farmer through 4 ways were 1) environmental factor to social factor, 2) social factor to economical factor and institutional factor, 3) technical factor to institutional factor and economical factor to institutional factor then would influence the productivity and income of the farmers. Improvement of all the factors would increase the productivity and income of dairy farmers.

## CONCLUSIONS

Productivity of dairy cattle in Central Java, which reflected in milk productivity was still low, The production of milk was only 9.2 liters / head / day on average. Farmer income levels are above minimum wage (UMR) in Central Java. Model of the influence of various business factors indicate that environmental factors, economic, institutional and social impact directly and further influence the milk productivity. The income of dairy cattle

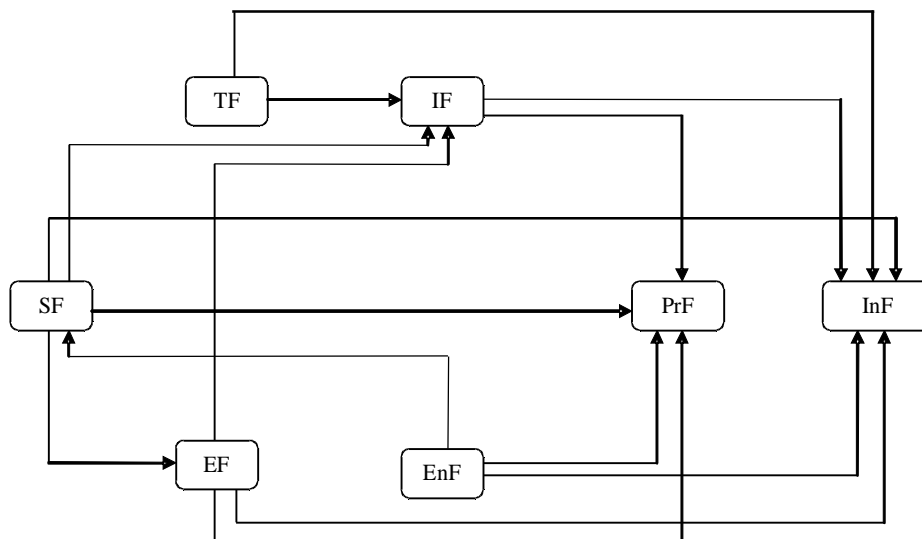

Figure 1. Model of the Influence of Various Factors on Productivity and Incomes of Farmer. TF: technical factor; SF: social factor; EF: economic factor; IF: institutional factor; EnF: environment factor; PrF: Productivity factor, InF: Income Factor

farmers directly were influenced by the environmental factors, technical, economic, institutional and social. The role of technical factors, social, economic, institutional and environment needs to be considered in efforts to increase business productivity and farmer incomes.

## REFERENCES

- Arsyad, L. 1999. *Ekonomi Pembangunan*. Edisi ke empat. Penerbit Sekolah Tinggi Ilmu Ekonomi YKPN, Yogyakarta.
- Dinas Peternakan dan Kesehatan Hewan Provinsi Jawa Tengah. 2011a. *Statistik Peternakan Tahun 2010*. Dinakkeswan, Jawa Tengah.
- Dinas Peternakan dan Kesehatan Hewan Provinsi Jawa Tengah. 2010b. *Kebijakan Pembangunan Peternakan dan Kesehatan Sapi Perah di Jawa Tengah dalam Rangka Penyediaan Susu Berkualitas*. Workshop Penguatan Kelembagaan Pengolahan Susu di Jawa Tengah. Dinas Perindustrian dan Perdagangan Provinsi Jawa Tengah. May 25 – 26, 2010.
- Direktorat Jenderal Peternakan dan Kesehatan Hewan. 2011. *Statistik Peternakan dan Kesehatan Hewan 2011*. Kementerian Pertanian, Jakarta.
- Firman, A. 2010. *Agribisnis Sapi Perah Perah dari Hulu Sampai Hilir*. Penerbit Widya Padjadjaran, Bandung.
- Ghozali, I. 2007. *Model Persamaan Struktural Konsep dan Aplikasi dengan Program AMOS 16.0*. Edisi III. Badan Penerbit Universitas Diponegoro, Semarang.
- Hendarto, R.M. 2000. *Analisis Potensi Daerah dalam Pembangunan Ekonomi*. Fakultas Ekonomi Universitas Diponegoro, Semarang.
- Lemeshow, S. and W.H. J. David. 1997. *Besar Sampel dalam Penelitian Kesehatan*. Gadjah Mada University Press, Yogyakarta (Translated by Dibyong Pramono).
- Mukson, T. Ekowati, M. Handayani and S. Gayatri. 2010. *The Potency of dairy cattle agribusiness development in Semarang regency, Central Java*. *Jurnal Pengembangan Peternakan Tropis*. 35(3):179-184.
- Mukson, Isbandi, K. Budiraharjo, M. Handayani and N.W. Listiani. 2010. *Profitability level and the role of family factors resources for developing dairy cattle farming in getasan-semarang district*. *Prosiding Seminar Nasional Ruminansia 2010*. Fakultas Peternakan Universitas Diponegoro, Semarang. p.127-130
- Mukson, Isbandi, S.I. Santosa and Sudjadmogo. 2011. *Potensi dan faktor pengembangan sapi perah di wilayah jalur pemasaran susu di jawa tengah*. *Proceeding of National Seminar*



- on Zootechniques for Indogenous Resources Development. ISAA Publication No. 1 Tahun 2012. Fakultas Peternakan Universitas Diponegoro, Semarang. p.271-276
- Nuraeni and Purwanto. 2006. Potensi sumberdaya dan analisis pendapatan usaha peternakan sapi perah di kabupaten Sinjai. *Jurnal Agrisistem*. 2(1): 8-17
- Peraturan Presiden RI. 2008. Kebijakan Industri Nasional. Per Pres No. 28 Tahun 2008.
- Prasetyo, E., T. Ekowati and Mukson. 2005. Kondisi dan potensi usahatani sapi perah di kabupaten Semarang. *J. Pengembangan Peternakan Tropis*. 30(2):110-118
- Singarimbun, M dan S. Effendi. 1989. *Metode Penelitian Survei*. LP3ES, Jakarta.
- Sudono, A. Rosdiana, R. Fina and B. Setiawan. 2003. *Beternak Sapi Perah Secara Intensif*. Penerbit Agro Media Pustaka, Jakarta.
- Suzuki, K, M. Kanameda, T. Ogawa, T.T.D. Nguyen, T.T.S. Dang, Q.H. Luu and D.U. Pfeiffer. 2006. Productivity and socio-economic profile of dairy cattle farmers amongst rural smallholder communities in northern Vietnam. *Livest. Sci.* 101(1-3): 242-250
- Thau, T.D. 2004. Factors affecting technical efficiency of household dairy cattle production in two communes of gialam district, Hanoi. *Journal of the International Society for Southeast Asian Agricultural Sciences*. 16(1):86-90.
- Toharmat, T. 2010. Potensi manfaat teknologi rekayasa nutrisi dan manajemen pemberian pakan dalam peningkatan produktivitas sapi perah nasional. *Prosiding Seminar Nasional Ruminansia 2010*. Fakultas Peternakan Universitas Diponegoro, Semarang. p.1-19
- Yulianto, H. 2011. Peningkatan Produksi dan Konsumsi Susu Segar dalam Upaya Meningkatkan Sumberdaya Manusia Berkualitas. *Seminar Milk Day : Fakultas Peternakan Universitas Diponegoro, Dinas Peternakan dan Kesehatan Hewan Prov. Jateng dan Direktorat Jenderal Pengolahan dan Pemasaran Hasil Pertanian. Kementerian Pertanian*. Semarang. June 7, 2011. p.1-5