

Wardiah Mohd DAHALAN^{1,2,3}, Hazlie MOKHLIS^{1,3}, Ab Halim Abu BAKAR^{1,3}, Jasrul Jamani JAMIAN^{1,4}

Department of Electrical Engineering, Faculty of Engineering, University of Malaya, 50603 Kuala Lumpur (1)
Department of Marine Elec. Engineering, University Kuala Lumpur, (Malaysian Institute of Marine Engineering Technology), Perak (2)
UM Power Energy Dedicated Advanced Centre (UMPEDAC), Level 4, Wisma R&D, University of Malaya, Kuala Lumpur, Malaysia (3)
Faculty of Electrical Engineering, Universiti Teknologi Malaysia(4)

The Simultaneous Application of Optimum Network Reconfiguration and Distributed Generation Sizing Using PSO for Power Loss Reduction

Abstract. The utilization of Distributed Generation (DG) sources in Distribution Power system is indeed vital as it is capable of solving problems especially pertaining to power losses due to an increasing demand for electrical energy. The location and optimal size of DG has become a prominent issue for the network to have lower power losses value. In order to reduce unnecessary power losses, the use of a combination reconfiguration method and DG units can assist the system to obtain optimal power loss in the network distribution. The primary idea is to have the reconfiguration process embedded with Distributed Generation (DG) and being operated simultaneously to reduce power losses and determine the optimal size of DG by using Particle Swarm Optimization (PSO). The objective of this paper is to focus on reducing the real power losses in the system as well as improving the voltage profile while fulfilling distribution constraints. The simulation results show that the use of simultaneous approach has resulted the lower power losses and better voltage profile of the system. A detail performance analysis is carried out on IEEE 33-bus systems demonstrate the effectiveness of the proposed methodology.

Streszczenie. W artykule przedstawiono metodę przeprowadzenia rekonfiguracji systemie elektroenergetycznym z wykorzystaniem generatorów rozproszonych. Do zadań głównych należy ograniczenie strat i optymalizacja rozmiarów generatorów, przy jednoczesnym zapewnieniu stabilności systemu. W rozwiązaniu wykorzystano metodę PSO. Przedstawiono wyniki badań symulacyjnych oraz analizę szczegółową dla systemu IEEE 33-liniowego. (Optymalizacja rekonfiguracji sieci elektroenergetycznej i rozmiarów generatorów rozproszonych w redukcji strat energetycznych – zastosowanie algorytmu PSO).

Keywords: Reconfiguration, Particle Swarm Optimization, distributed generation, Power loss and radial distribution systems.

Słowa kluczowe: rekonfiguracja, PSO, generacja rozproszona, straty energii, sieć elektroenergetyczna gwiazdista.

Introduction

The performance of distribution system becomes inefficient due to the reduction in voltage magnitude and increase in distribution losses. Since the distribution power system is the final stage of the distribution process from the source to the individual customer, it has seemed to contribute the greatest amount of power loss in which finally resulted the instability in the system. Thus, many researchers have been focusing on power loss minimization in the network reconfiguration of the distribution system by using various methods. And among the most effective and recent method used is reconfiguration and DG.

The implementation of DG and other devices in distribution system required a high installation cost. Therefore, appropriate size and location of DG is highly important in maintaining the network stability and reduce the power losses in the system. Meanwhile, the installation of reconfiguration network is much simpler and cost efficient compared to other techniques. In general, reconfiguration have two primary objectives which are to provide the maximum amount of electrical supply to the end customers and reconfigure the network system automatically as soon as the problems arise. Thus, various reconfiguration methods have been proposed to solve the power loss problem and each method has the respective advantages and disadvantages.

Based on the literature reports, we can categorize the methods used in three types. First, some researchers focus on determining the DG size and location to reduce power loss in the distribution system without considering the network reconfiguration. Second, there are also researchers who only focus on reconfiguration of the network to find the optimal power losses but ignore the DG part. Meanwhile, in the third category, the researchers focus on both DG and reconfiguration. Those researchers find out the optimal size of DG first which then only the results obtained being applied in the network reconfiguration. In general, they tend to solve the problem separately. For example the analysis in

[1], the researcher has introduced reconfiguration on real application by employing a method based on Genetic Algorithm (GA) to determine the minimal power loss in the distribution network. In their works, the new reconfiguration strategy and novel Genetic operators are being used. The results obtained are able to reduce the computation time and power loss which in fact better in the system compared to the traditional GA. Meanwhile, Shirmohammadi et al. [2] also described heuristic optimization technique for the reconfiguration of distribution networks to decrease their resistive line losses. In another approach, the authors in [3] present a Refined Plant Growth Algorithm (PGSA) simulation for distribution network reconfiguration. The proposed method is combined with the heuristic search rule for node search purpose in order to reduce the computation time. K.Satish et. al. [4] proposed a Bacterial Foraging Algorithm (BFO) approach to find the network reconfiguration in minimizing power loss. The simulation result illustrates that their proposed approach is efficient and easily be extended for other complex system. In brief, the researcher of [1-7] had used the reconfiguration approach to improve the network performance using various methods.

Meanwhile, the researchers of [8-14] for instance, had been using DG to improve the power losses in the distribution system by positioning the optimal location and size of DG units. In addition, the authors of [15-20], using both technique reconfiguration and DG sizing to find the optimal power losses, however, both techniques are operated separately. [15] for example implement the network reconfiguration process by using the TOPO (Tie-Open Point Optimization) technique. The optimal location of the Distributed Generation and the size of DG were then identified using pre-determined sensitivity indices and Evolutionary Programming method respectively. The network reconfiguration is only done when the optimal location and appropriate size of DG are found. Other optimization methods had also been employed to solve the

reconfiguration with the DG problem of distribution network such as Genetic Algorithm (GA) [16], Particle Swarm Optimization (PSO) [17], Ant Search Colony (ASC) [18], Tabu Search [19] and others. Thus far, there are several techniques applied in the previous works. However, none of the researchers have combined the two methods simultaneously to achieve optimal power losses.

In this paper, the researcher is trying to overcome the distribution problem by finding out the best setting for optimal reconfiguration and DG sizing simultaneously. In other words, both numbers of switches and DG size are changing simultaneously during the process. In order to achieve the optimal power loss, PSO method has been proposed in reconfiguration steps taking into consideration its capacity and flexibility for searching optimal solution. In addition, PSO is easier to be implemented because only a few parameters need to be adjusted. Five different cases have been conducted during the analysis which comprise of distribution network with and without DGs. The system is operating to find the optimal reconfiguration and size of DG based on a simultaneous concept by using MATLAB software. The simulation results show that the use of simultaneous approach has successfully generated the optimal power loss and improved voltage profile of the system as compared to the previous approach. The details of these algorithms are explained in the next section.

Mathematical Model for Distribution Network Reconfiguration Problem

Distributing network reconfiguration plays a vital role in finding the radial operating structure in order to minimize the system power losses and at the same time maintaining operating constraints. Thus, the problem can be formulated as follows [17].

$$(1) \text{ Min } P_{\text{loss}} = \sum_{i=1}^n |I_i|^2 k_i R_i \quad i \in N$$

where is P_{loss} = loss function, I_i = current in the branch i , R_i = resistance of the branch i , N is the total number of branches and k_i is the variable that represents the topology status of the branches (1=close, 0= open).

Subject to:

a) Node voltage constraint:

The value of V_i at each node must be within their acceptable ranges to maintain power quality

$$(2) \quad V_{\text{min}} \leq V_{\text{bus}} \leq V_{\text{max}}$$

The standard minimum voltage used is 0.95 and maximum voltage is 1.05 ($\pm 5\%$).

b) Generator operation constraints:

The entire DG units are required to function within the stipulated limit. $P_{i_{\text{min}}}$ and $P_{i_{\text{max}}}$ are the lower and upper bound of DG output respectively.

$$(3) \quad P_{i_{\text{min}}} \leq P_{DG_i} \leq P_{i_{\text{max}}}$$

c) Feeder capability limits:

$$(4) \quad |I_k| \leq I_k^{\text{max}} \quad k \in \{1,2,3,\dots,l\}$$

where I_k^{max} = maximum current capability of branch k .

- Radial configuration format.

- No load-point interruption

Particle Swarm Optimization Algorithm (PSO)

Particle Swarm Optimization has been broadly applied by the majority researcher to solve problems related to optimization problems in power system. The PSO method is

created according to the study of the behavior of clustered social animals such as fish and bird. The birds or fish will move towards the food in certain speed or position. Their movement will depend on their own experience and experience from other 'friends' in the group P_{best} and G_{best} .

The new velocity, V_m^{t+1} and the new position, X_m^{t+1} for the fish or birds are obtained using Eq.(5) and (6) [21].

$$(5) \quad V_m^{t+1} = \omega \times V_m^t + wf_1 \times ran_1 \times (P_{bm}^t - X_m^t) + wf_2 \times ran_2 \times (G_b^t - X_m^t)$$

$$(6) \quad X_m^{t+1} = X_m^t + V_m^{t+1}$$

where V_m^t is the velocity of particle m in iteration t , X_m^t is the position of particle m in iteration t , ran_1 and ran_2 are the random numbers between 0 and 1. P_{bm}^t is the best value of the fitness function that has been achieved by particle m before iteration t . G_b^t is the best value of the fitness function that has been achieved so far by any particle. Constants wf_1 and wf_2 are weighting factors of the random acceleration terms, which attract each particle towards P_{best} and G_{best} positions. Lower values of fitness function allow particles to move farther from the target region before they return. The inertia weight ω_i is typically set according to the following equation:

$$(7) \quad \omega_i(n+1) = \omega_i^{\text{max}} - \frac{\omega_i^{\text{max}} - \omega_i^{\text{min}}}{n_{\text{max}}} \times n$$

In Eq.(7), n_{max} is the maximum number of iterations and n

is the current iteration number. $\omega_{i_{\text{max}}}$ and $\omega_{i_{\text{min}}}$ are maximum and minimum of the inertia weights, respectively. The simple process of implementation of PSO algorithm is as follows:

Step A- Initialization- generate randomly all particles

Step B- Evaluate the fitness function

Step C- Determine P_{best} and G_{best} for all populations

Step D- Evaluate the new speed for each population

Step E- Update the existing position to a new position

Step F- Update the existing speed to the new speed

Step G- Check the stopping criteria –otherwise go to

Step B.

In this work, the particles consist of the tie line (S) and DG size (Pg) as shown in Eq.(8).

$$(8) \quad X_{\text{particle}} = \{S_1, S_2, \dots, S_\beta, Pg_1, Pg_2, \dots, Pg_\alpha\}$$

where β is the number of tie line and α is the number of DG.

Simulation and Analysis of the Results

The test system for the case study consisting of 33-bus radial distribution system is shown in Fig.1. The system consists of one feeder, 32 normally closed tie line and five normally open tie lines (dotted line) and located on branch No. 33, 34, 35, 36 and 37. The system load is assumed to be constant and $S_{\text{base}} = 100\text{MVA}$. The line and load data details can be referred in [11]. The total load in the system is 3715kW. The minimum and maximum voltages are set at 0.95 and 1.05p.u. respectively. All calculations for this method are carried out in the per-unit system. The convergence value is taken as 0.0001.

Descriptions on five different case studies

From the base system, five different cases are formed and shall be analyzed for their robustness and efficiency of PSO in obtaining the best configuration. The lists of cases are:

- Case 1: All the tie switches in the network are open and there are no DG units added into the system. This network is an original 33-bus distribution network without any modification.
- Case 2: Reconfiguration technique is employed in the system in Case 1 with the objective to reduce the power losses in the system.
- Case 3: Four DG units that operated in PQ mode are placed at the optimal location which is at buses 6, 12, 25 and 32 in the system. The impacts of all these DGs are analyzed without reconfiguration action.
- Case 4: The conditions of the system are similar to the Case 3, but the reconfiguration action was being carried out after the optimal size of DG obtained.
- Case 5: Similar with condition in case 4. However, the reconfiguration process operates simultaneously with DG.

The proposed method is written in MATLAB (version 2010b). For the simulation, the size of the population is set to 50. The location of DGs is placed on bus number 6, 16, 22 and 29. Meanwhile the size of DG will be obtained from the proposed method. Four cases are considered:

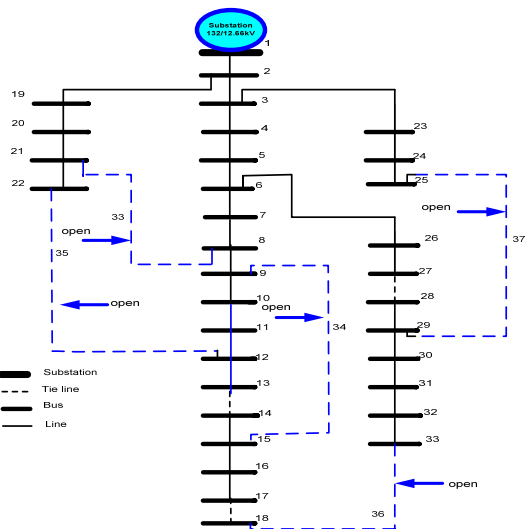

Fig.1. Initial configuration of the 33- bus radial distribution system

Optimal DG Sizing and Reconfiguration in Distribution Network Simultaneously

As mentioned in the previous section, the analysis of reconfiguration involved the network with and without DG units. In the case of a network with DG, the optimal size of DG units is obtained from the simulation in which both parameters DG size and the switches opened (in equation (8)) are adjusted during simulation simultaneously. The size of each DG is already set with the limitation range less than 5MW in the program. In this work, we only manipulate the optimal size of DG while the location of DG is fixed. DG location shall be constant as a controlled measure in order to observe the responding changes of DG sizing. In addition, it is rather impractical to see DG location varies on the real problem situation. Tie switch and sectionalizing switch are considered as the main control variables. The optimal power losses are based on flexible switches while the optimal size of DG depends on the optimal power

losses. After this simulation is run randomly at approximately 100 times by using MATLAB software, then only the minimum power loss with optimal DG size is selected. The results obtained consists of the five opened switches, total power loss and four optimal DG sizing. From the result of the case study, it can be seen from the Table 1 shows that four DGs are installed in different locations with different size.

Table 1. The optimal size of DG of the proposed method

No. of DG	Location (Bus)	Case 4	Case 5
		Reconfiguration & DG (separately)	Reconfiguration & DG (simultaneously)
		DG size	
DG 1	6	1.0185	1.0523
DG 2	16	0.9034	0.6550
DG 3	22	0.5224	0.5545
DG 4	29	1.6559	1.7245
Total Size of DG		4.1002	3.9863

The size of DG in four cases are varies and run at range $0 < DG \leq 5$. The total optimum DGs size operates for case 4 and case 5 is at approximately 4.1002MW and 3.9863MW respectively. The analysis of the results with this method is discussed in detail in the next subsection

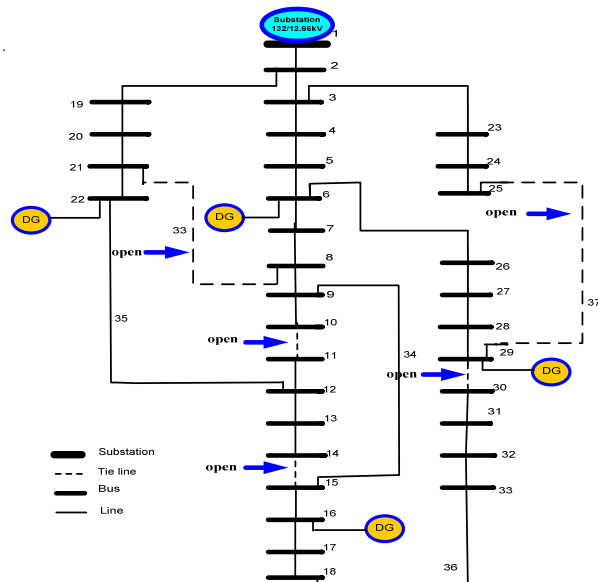

Fig.2. Single-line diagram of 33-bus radial distribution system after reconfiguration with distributed generation (organize separately)

Impact of Reconfiguration and DG installation Technique of the Distribution System

Since the reconfiguration technique has changed the original configuration network as well as a number of feeders, the impacts of this technique to the power losses of the system need to be studied. The schematic diagram of the system after reconfiguration with DG installation (case 4 and case 5) is illustrated in Fig. 2 and Fig. 3. The DG is placed at bus number 6, 16, 22 and 29 as shown on the diagram. The numerical results for the five cases are summarized in Table 2. As mention earlier, the output of the result display five opened switches, optimal total power loss and optimal DG size as shown in Table 2. From the analysis of the results, the system which operates with DG technique in case 3 produced a lower power loss as compared to case 2 in which the reconfiguration technique is applied. With the existence of DG in case 3, the system has been improved about 12.1kW (117.2 kW to 105.1kW). Although the network configuration has changed the power flow direction which

gives the lower power loss in the system, the reconfiguration technique still has its own limitation. Hence, this proves that the existence of DG in the distribution system is indeed significant in ensuring a lower power loss.

However, optimal power loss can be further improved by the combination of both techniques into the distribution system. This can be seen in case 4 in which the loss has been improved further from 105.1 kW to 98.6 kW. Such combination however does incur a slight drawback because the computational time (CPU) is rather long since both techniques operate separately. To further improve the system, the latest invention combines both factors of DG and reconfiguration together and they operate simultaneously as depicted in case 5. It means during

simulation, both variables (switches and size of DG) are adjusted at the same time. The simultaneous concept has indeed proven to give more global optimal results as stated in case 5. The power loss has been improved about 9.3kW.5kW (98.6kW – 89.3kW) .But, if we compare to case 1, this technique has in total achieved the improvement of 57.3%. Meanwhile, the computing time of the case 5 is 15.10 seconds faster as compared to case 4 and the opened switches are also changes to 7, 12, 29, 33 and 37. In addition, the maximum iteration to reach the optimal value is only requires 54 for a case 5 and followed by 61 for case 4 for the proposed method to converge.

Table 2. Results of case study

Case	Opened Switches					Power Loss (kW)	DG sizes (MW)				Iteration	CPU time
	Sw-1	Sw-2	Sw-3	Sw-4	Sw-5		DG-1	DG-2	DG-3	DG-4		
Case 1 *i	33	34	35	36	37	202.3	-	-	-	-	-	-
Case 2 *R	7	9	14	28	32	117.2	-	-	-	-	68	29.09
Case 3 *G	33	34	35	36	37	105.1	1.0038	0.9004	0.5167	1.5726	-	-
Case 4 *R&G	29	14	10	33	37	98.6	1.0439	0.5018	1.5312	2.009	61	25.15
Case 5 **R&G	7	12	29	33	37	89.3	1.0523	0.6545	0.6550	1.8245	54	10.05

*i=initial, *R=reconfiguration, *G=Distributed Generation, *R&G =operate separately, **R&G=operate simultaneously

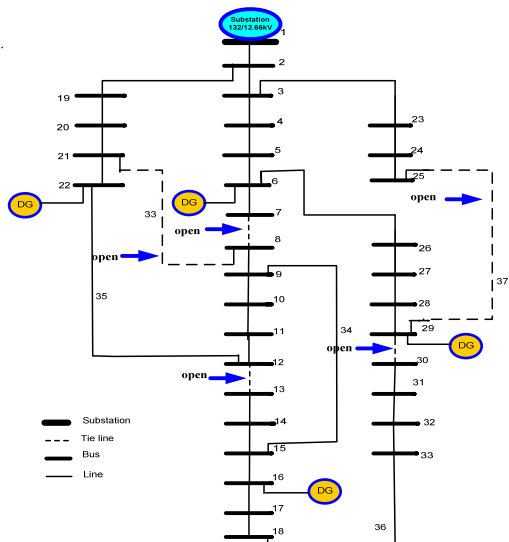

Fig.3. Single-line diagram of 33-bus radial distribution system after reconfiguration with distributed generation (organize simultaneously)

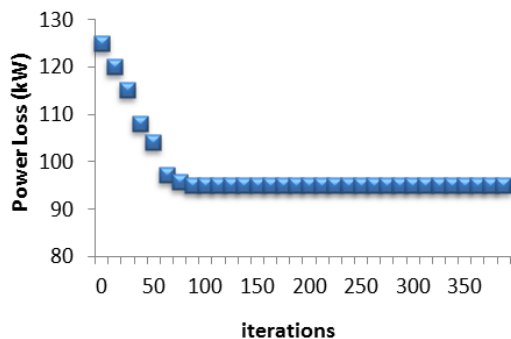

Fig.4. Convergence performance of PSO for the best solution (case 5)

This shows that the proposed method is capable of solving problems faster during the simulation and converge them within a short period of time as compared to other methods. The convergence performance based on the

simultaneous concept in case 5 is depicted in Fig. 4. Meanwhile, the consistency method analysis for both cases are illustrated in Fig. 5

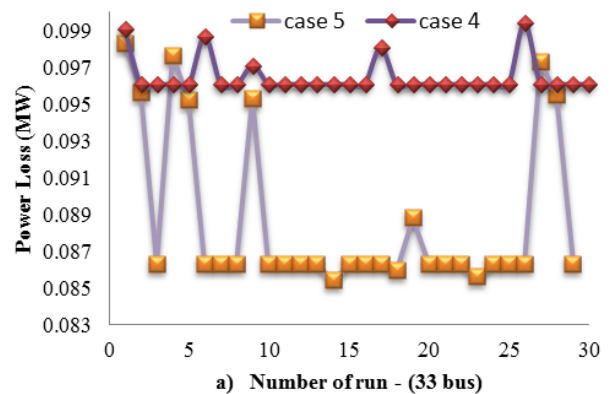

Fig. 5. Consistency method analysis of 33-bus system

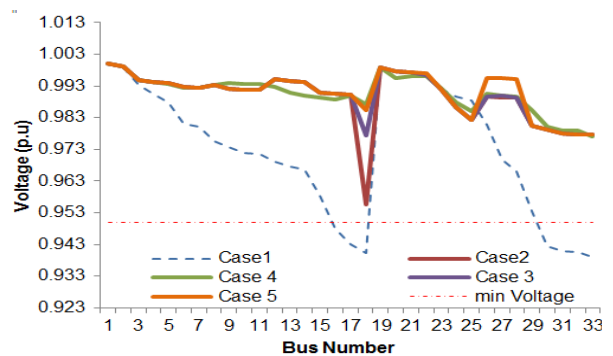

Fig.6. Performance of voltage profile for 33 bus radial distribution system.

Beside generating the lowest power losses, the network reconfiguration also improves the overall voltage profile of the distribution system. Fig.6 illustrates is the performance of the voltage profile on 33-bus distribution system of all cases on voltage profile improvement achieved by the proposed algorithms. In this case, there are obvious

improvements on voltage value between bus 17 till 19 and 25 till 29 . The minimum bus voltage at base case is equal 0.9430 (case 1) which is under the minimum voltage limit and then being raised to nearly 0.9980 (case 5) after reconfiguration and DG technique is applied. The rest of the bus only has the slightly different value or some of the parts is almost the same.. The relationship between cases and power loss are illustrated in Fig. 7.

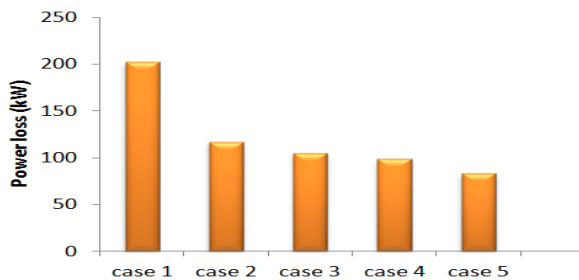

Fig.7. Comparison of power losses between cases

Conclusion

A new approach which based on simultaneous concept technique has been developed in this paper to find the optimal power losses by turning on/off the tie switch and sectionalizing switch and determine the optimum value of DG size simultaneously on the distribution network reconfiguration. A 33-bus distribution system with four distributed generation is used to demonstrate the effectiveness of the proposed technique. In this paper, five cases are considered as explained in the above section.

From the analysis and simulation of the results, the overall perspectives between the five cases show that the case 5 result surpasses among the other cases. The implementation reconfiguration and DG technique in 33-bus system which is operated simultaneously (case 5) has shown tremendous improvement in term of computational time, number of iterations to reach the optimal value of power losses and the optimum value of DG sizing. Experimental results indicated that the optimal open-close status of the switches can be identified which give the minimum power loss while maintain bus voltage magnitudes within the acceptable limits. Based on these reasons, it is strongly expected that the simultaneous concept by using PSO method is capable of solving large-scale problems arose in network reconfiguration as compared to the existing methods.

This work is supported by the Ministry of Higher Education Malaysia under the Exploratory Research Grant Scheme (ERGS), Grant Code: ER025-2011A.

REFERENCES

- [1] J. Mendoza, R. Lopez, D. Morales, E. López, R. Moraga, and P. Dessante, "Minimal Loss Reconfiguration using Genetic Algorithm with Restricted Population and Addressed Operators: Real Application", *IEEE Transactions on Power Systems*, vol. 21, no.2, May. 2006, pp. 948-954.
- [2] D. Shirmohammadi, H.W. Hong, "Reconfiguration of electric distribution networks for resistive line loss reduction", *IEEE Trans. Power Syst.* 4 (1) (1989) 1492–1498.
- [3] J.Y.Fang ZongWang, "A Refined Plant Growth Simulation Algorithm for Distribution Network Reconfiguration", *IEEE Trans. on Power Systems*, 2009, pp.4244-4738.
- [4] K. Sathish Kumar, T. Jayabarathi, "Power system reconfiguration and loss minimization for distribution systems using bacterial foraging optimization algorithm," *Electrical Power and Energy Systems* 36, Nov 2011, pp. 13–17.

- [5] I.Z. Zhu, "Optimal reconfiguration of electrical distribution networks using the refined genetic algorithm", *Elect. Power Syst. Res.* 62(2002) 37–42.
- [6] Y.C.Huang, "Enhanced genetic algorithm-based fuzzy multi objective approach to distribution network reconfiguration", *Proc. Inst. Elect. Eng.* 149 (5) (2002) 615–620.
- [7] H. Kim, Y. Ko, "Artificial neural network based feeder reconfiguration for loss reduction in distribution systems", *IEEE Trans. Power Del.* 8 (3) (1993) 1356–1367.
- [8] M.Padma Lalitha, V.C Veera Reddy, V. Usha, "Optimal DG Placement for Maximum Loss Reduction in Radial Distribution System using ABC algorithm". *Journal of Theoretical and Applied Information Technology*, 2005-2010
- [9] M.Padma Lalitha, V.C Veera Reddy, V. Usha, "Optimal DG Placement for Minimum Real Power Loss in Radial Distribution Systems Using PSO". *Journal of Theoretical and Applied Information Technology*, 2005-2010.
- [10] E. Lopez, h. Opaso., "Online reconfiguration considering variability demand", applications to real networks, *IEEE Trans. Power Syst.* 19 (1) (Singh, Devender Singh, and K.S. Verma, "GA based optimal sizing and placement of distributed generation for loss minimization", *International Journal of Electrical and Computer Engineering* 2:8 2007, pp 556-562 (ONLINE), ISSN : 1307-5179.
- [11] M. H. Moradi and M. Abedini, A combination of genetic algorithm and particle swarm optimization for optimal DG location and sizing in distribution systems, *International Journal of Electrical Power & Energy Systems*, vol. 34, no. 1, Jan. 2012, pp. 66-74.
- [12] Nerves, A.C.; Roncesvalles, J.C.K.; , Application of evolutionary programming to optimal siting and sizing and optimal scheduling of distributed generation, *TENCON 2009 - 2009 IEEE Region 10 Conference* , vol., no., pp.1-6, 23-26 Jan. 2009.
- [13] Yasin, Z.M.; Rahman, T.K.A.; Musirin, I.; Rahim, S.R.A., Optimal sizing of distributed generation by using quantum-inspired evolutionary programming, *Power Engineering and Optimization Conference (PEOCO), 2010 4th International* , vol., no., 23-24 June 2010, pp.468-473.
- [14] Ching-Tzong Su, Chung-Fu Chang and Ji-Pyng Chiou, "Distribution Network Reconfiguration for Loss Reduction by Ant Colony Search Algorithm", *Electric Power Systems Research*, Vol. 75, No. 2-3, August 2005, pp. 190–199.
- [15] Yasin, Z.M.; Rahman, T.K.A.; Network Reconfiguration in a Power Distribution System under Fault Condition with the Presence of Distributed Generation, *International Conference on Energy and Environment (ICEE), 28-30 Aug. 2006.*
- [16] Z. Zhu, "Optimal reconfiguration of electrical distribution networks using the refined GA" *Electric Power System Research*, Vol. 62, 2002, pp. 37-84.
- [17] J.Olamie, T.Niknam, G. Gharehpetian, "Application of Particle Swarm Optimization for Distribution feeder Reconfiguration Considering Distributed Generators", *Applied Mathematics and Computation*, 2008, pp. 575-586.
- [18] Y. K. Wu, C. Y. Lee, L. C. Liu and S. H. Tsai, Study of Reconfiguration for the Distribution System With Distributed Generators, *IEEE Trans. on Power Del.* 25, No. 3, 1678-1685.
- [19] N. Rugithacharencheep; S. Sirisumarannukul, Feeder reconfiguration for loss reduction in distribution system with *Journal*, vol 3, 2009, pp. 47-54.
- [20] K. Prasad, R. Ranjan, Optimal reconfiguration of radial distribution system using a fuzzy mutated genetic algorithm, *IEEE Trans. Power Del.* 20 (2) (2005) 1211–1213.
- [21] J.J. Jamian, M.W. Mustafa, H. Mokhlis, M.N. Abdullah, Comparative Study on Distributed Generator Sizing Using Three Types of Particle Swarm Optimization, *Intelligent Systems, Modelling and Simulation (ISMS), 2012 Third International Conference* no., 8-10 Feb. 2012, 131-136

Authors: Wardiah Mohd Dahalan, University Kuala Lumpur, E-mail: wardiah@mimet.unikl.edu.my, Dr. Hazlie Mokhlis, University of Malaya, Kuala Lumpur, E-mail: hazi@um.edu.my, Dr. Ab Halim Abu Bakar, University of Malaya, Kuala Lumpur, E-mail: a.halim@um.edu.my, Jasrul Jamani Jamian, Universiti Teknologi Malaysia E-mail: jasrul@fke.utm.my
The correspondence address is: E-mail: wardiah@mimet.unikl.edu.my