

Absolute Polar Duty Cycle Division Multiplexing: An Economical and Spectral Efficient Multiplexing Technique

M.K.Abdullah, Amin Malek mohammadi, *Member, IEEE*, G.A.Mahdiraji, A.F.Abas, *Member, IEEE*, M. Mokhtar
Photonic Laboratory, Department of Computer and Communication Systems Engineering, Faculty of Engineering,
University Putra Malaysia, 43400 Serdang, Selangor, Malaysia
aminmalek_m@ieee.org

Abstract—A new multiplexing technique based on duty cycle division is proposed, under the name: Absolute Polar Duty Cycle Division Multiplexing (APDCDM). The new technique allows for more efficient use of time slots as well as the spectrum, taking the advantage of both the conventional TDM and FDM. The basic properties based on theoretical analysis as well as simulation studies have been done to evaluate the performance of this technique based on the signal energy and symbol error rate (SER). In this paper the performance of Absolute Polar Duty Cycle Division Multiplexing is compared with multilevel M-ary as well as with the time division multiplexing (TDM) techniques. The simulation has been set for wireless transmission based on free space propagation model with adaptive white Gaussian noise (AWGN). PSK and QAM are used as modulation schemes to evaluate these techniques against data rates and number of users. The study shows that by increasing the number of users, the energy per bit in APDCDM has better performance than that of TDM technique. The simulation result correspond with the theoretical study shows that Absolute Polar Duty Cycle Division Multiplexing (APDCDM), has better SER than TDM.

I. INTRODUCTION

Multiplexing is one of the fundamental and essential parts in today's digital communications. The expected growth in demand for existing narrowband services and future broadband-interactive, multimedia-entertainment, and educational services has led to a need for high capacity networks. The success and the increasing diffusion of wireless system have made band width a scarce resource. Therefore, efficient use of limited available band width is mandatory.

Whenever the transmission capacity of a medium linking two devices is greater than the transmission needs of the devices, the link can be shared, much as a large water pipe can carry water to several separate houses at once.

Multiplexing is the set of techniques that allows the simultaneous transmission of multiple signals across a single data link. There are several ways in which multiplexing can be achieved such as Frequency Division Multiplexing (FDM) [1, 2, 3], Time Division Multiplexing (TDM) [4, 5, 6], Code Division Multiplexing (CDM) [7, 8, 15] and multilevel M-ary signaling. M-ary is normally used to transmit multiple amplitudes. The main purpose of M-ary is to increase the bandwidth efficiency whereby, many bits can be transmitted by the signal symbol. If each bit is assumed to represent a different user, then M-ary can also be used for multiplexing.

The goals of all multiplexing techniques are to support as many users at as high speed and at the lowest cost possible [10]. TDM is the most widely used multiplexing technique in today's communication, in which the main issue is a clock recovery that may render the system highly complicated and costly for TDM system [10]. Therefore, many investigations have been done to design and develop reliable and cost-effective clock recovery modules for TDM in both electrical and optical versions [11]. Realizing these problems an absolute polar duty cycle division multiplexing (APDCDM) is proposed in this study and implemented in wireless channel based on free space propagation model. In this technique, users with different duty cycle can transmit simultaneously over the communication media. The original data can be easily distinguished from the received signal at the receiver side, based on the signal amplitude and duty cycle.

The purpose of this paper is to introduce the new multiplexing technique based on duty cycle division multiplexing and compare this multiplexing technique with TDM as well as with multilevel M-ary. In section II of the article the basic properties of APDCDM are explained based on theoretical analysis. The results from the simulation study are discussed in subsequent section which is followed by a conclusion.

II. THE WORKING PRINCIPLE

A. Basic properties

The absolute polar duty cycle division multiplexing (APDCDM) is based on having each channel modulated with a unique RZ duty cycle. In this technique each multiplexing user transmits bit '0' with zero volts and for the case of bit one, the odd users transmit with +A volts and the even users transmit with -A volts. Based on the linear distribution of duty cycle, the i^{th} multiplexing user transmits bit 1 within T_i second which is calculated as

$$T_i = i * \frac{T_s}{n+1} \text{ (Seconds)} \quad (1)$$

The first user has the shortest pulse width which is calculate using equation (1), when $i=1$ and the n^{th} user has the longest pulse width, when $i=n$. Therefore, different users share the communication medium to transmit in the same time period and at same frequency but different duty cycles. Based on the 2^n possible bits combination (Figure 1.a), each of these

combinations produce a unique symbol for the absolute polar multiplexed signals. Figure 1.f shows the absolute polar multiplexed symbols for the eight possible combinations of bits for three users. Having the knowledge about this uniqueness at the receiver side, the original data for each user can be easily distinguished and recovered by taking one sample per slot for 'n+1' slots per 'Ts' seconds. This technique allows for automatic bit error detection and correction based on the sequence of sampled amplitudes per symbol duration for the case of multiplexing 'n' users, if only one sample per slot is taken, then, the first sample (taken from the first slot), has $\lceil \frac{n+1}{2} \rceil + 1$ (when n is odd), and $(n/2)+1$ (when n is even) possible levels, the second sample (taken from second slot), has $(n+1)/2$ and $(n/2)$ possible levels. When 'n' is odd and even respectively, the n^{th} sample has only two possible levels (0 or A volts), and the last sample has one possible level which is 0 volts. Note that the maximum amplitudes of the multiplexed signal are (2).

$$\begin{cases} A_{max} = A \left(\frac{n}{2} \right) & n = \text{even} \\ A_{max} = A \left[\frac{n+1}{2} \right] & n = \text{odd} \end{cases} \quad (2)$$

The minimum amplitude that the multiplexed signal may take is '0' volt. The minimum amplitude only happens, when all users transmit bit '0'. For example in Figure 1, case 1 has the minimum amplitude of '0' volts in the first slot. There are n+1 number of slots per symbol in the multiplexed signals. All of these slots have an equal duration that can be calculated using equation (3)

$$T_{slot_k} = \frac{T_s}{n+1} \quad (3)$$

Case	1	2	3	4	5	6	7	8
User1	0	1	0	1	0	1	0	1
User2	0	0	1	1	0	0	1	1
User3	0	0	0	0	1	1	1	1

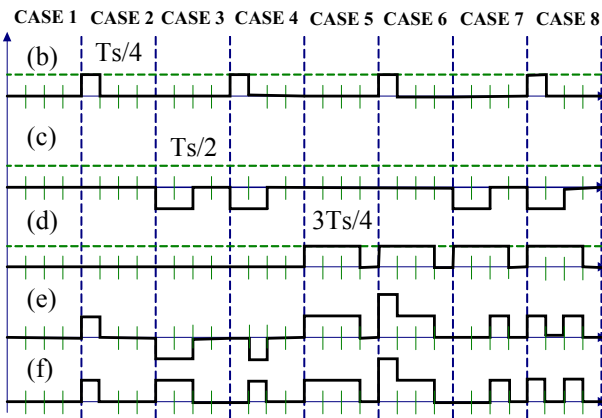

Fig. 1.(a) 8 possible combination of bits for 3 users; (b), (c), (d) Three multiplexing users with duty cycle of 25%,50% and 75% of Ts for user 1 , 2 and 3 respectively and (e) Summation signal of the 3 users.(f) Absolute polar multiplexed signal.

B. Average energy per symbol

Average energy/power per bit can be calculated from energy power spectrum density (E/PSD) or more simply, it can be calculated by taking the average energy/power per symbol for all the 2^n possible combination of bits. The later method was utilized in this paper. Figure 2 illustrates an example of calculating average energy per bit for the case of multiplexing 3 users. The average energy per bit for this method is formulized as:

$$E_{avg}^{bit} = \begin{cases} \left[\frac{n+1}{8n} \right] * A^2 T_s & n = \text{odd} \\ \left[\frac{n+2}{8(n+1)} \right] * A^2 T_s & n = \text{even} \end{cases} \quad (4)$$

Where 'A' is the signal amplitude in volt, 'Ts' is signal symbol duration in second, and 'n' is number of users.

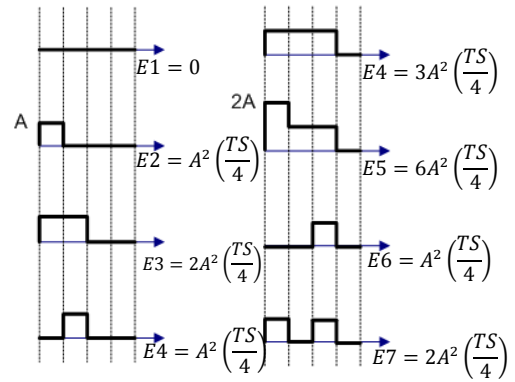

Fig. 2.Absolute polar multiplexed symbols for 8 cases. The average energy per bit for 3 users will be: $E_{avg} = \frac{16A^2 \left(\frac{T_s}{4} \right)}{3 * 2^3} = 0.1667$

C. Comparison of APDCDM with M-ary and TDM technique

M-ary signaling is normally used to transmit multiple amplitudes, each one representing two bits or more. The main purpose of M-ary is to increase the bandwidth efficiency whereby, many bits can be transmitted by the signal symbol. If each bit is assumed to represent a different user, then M-ary can also be used for multiplexing, thus worthy of comparison with the new scheme. Two comparisons are done based on the number of signal voltage levels and on the average energy per bit versus number of users. Figure 3, shows the theoretical results for the signal voltage level versus number of users for the APDCDM, TDM and M-ary techniques. The comparison shows that the number of voltage levels in the TDM remained fixed to two levels, for the APDCDM technique, it increased as $\lceil \frac{n+1}{2} \rceil + 1$, when the number of users is odd and $\left(\frac{n}{2} \right) + 1$ when the number of users are even, and for M-ary it increased as 2^n . Thus in order to multiplex 7 users, the TDM, APDCDM, and M-ary techniques require 2, 5 and 128 signal voltage levels respectively. This result shows the disadvantage

of the M-ary technique which makes it impossible to use as a multiplexing technique for high number of users. Next comparison was continued between TDM and APDCD only.

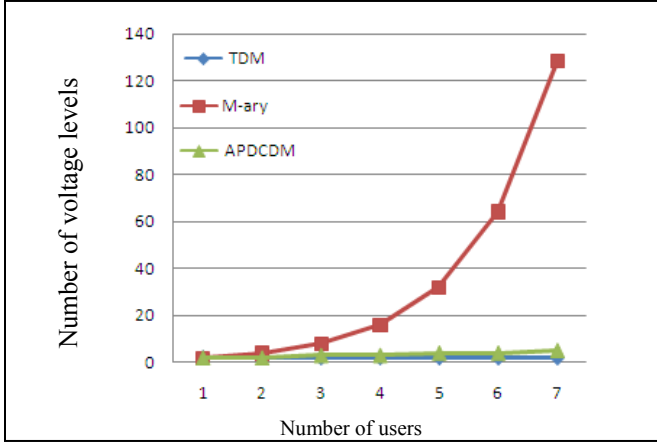

Fig.3. Number of signal voltage levels versus number of users for the M-ary, TDM and APDCDM techniques

The next comparison is done based on the theoretical results for the signal energy. The average energy per bit for the Absolute Polar Duty Cycle Division Multiplexing (APDCDM) is calculated based on the equation (4) as presented in Figure 2. For the TDM, the same method is applied, which is defined as:

$$E_{avg\ bit} = \left(\frac{1}{2n}\right) A^2 T \quad (5)$$

Figure 4 shows the average energy per bit for TDM and APDCDM for multiplexing up to 20 users. The Figure shows that the average energy per bit of absolute polar duty cycle division multiplexing decreased slowly with the number of multiplexing user whereas the average energy per bit for TDM reduced rapidly. So Absolute polar duty cycle division multiplexing is able to support higher number of multiplexing users considering the energy per bit only. Other advantage of absolute polar duty cycle division multiplexing, including simple transmission design, is capability of better clock recovery. For all possible symbols, there are transitions in each symbol except for the case that all users transmit bit 0 which probability is low $(1/2^n)$. The transition is very useful to recover the receiver clock (synchronization). The elaboration of this feature of APDCDM is not within the scope of this paper.

As far as transmitter design is concerned, the optical time division multiplexing technique requires one modulator for each user [16] and the use of multiple modulators is costly and lead to cross-talks [5,9] but, in Absolute polar duty cycle division multiplexing we use only one modulator for all users (Figure5). This is much cheaper and at the same time it avoids cross talk problems.

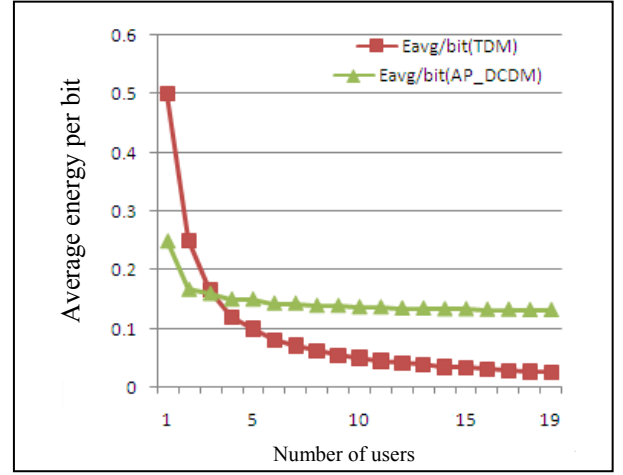

Fig.4. Normalized average energy per bit versus number of users for APDCDM (APDCDM) and TDM

III. SIMULATION

A schematic diagram of the APDCDM is shown in figure 5. In the transmitter side, the duty cycle of each user changed based on some algorithms. Users with different duty cycles are combined together and then, the absolute of that signal will transmit. It was assumed in this study that the medium is wireless and the entire configuration for wireless transmission with adaptive white Gaussian noise (AWGN), M-PSK and M-QAM was applied as modulation schemes. In this simulation we assumed up to 15 users as the number of multiplexing users, 5000 pulses per simulation, free space propagation loss as propagation model, 16 dB and 20 dB as transmitter and receiver gain respectively and 4 GHz as carrier frequency. The simulation was done based on two main important factors which are attenuation and noise. As the transmitter and receiver antenna were assumed to be in light of sight, therefore, the free space propagation model was used to calculate the attenuation in the communication media calculated based on the Friis free space equation [12, 16] which is:

$$Pr = \frac{P_T * G_T * G_r * c^2}{[4 * \pi * d]^2 * l * f^2} \quad (6)$$

where 'Pt', 'Pr' are the transmit and receive power in watts, 'Gt' and 'Gr' are the transmitter and receiver antenna gain, 'c' is the speed of light which is $3 * 10^8 m/s$ [13], 'd' is the distance between transmitter and receiver in meters, 'f' is the carrier frequencies. 'Pt' is assumed to be the same as baseband signal over which is calculated from the energy content of the multiplexed signals shown in Eq. (4) and (5) for APDCDM and TDM respectively. The amount of noise that is considered in communication media is calculated by [12, 14]

$$P_N = K * T_n * B_n \quad (7)$$

Where 'Pn' is thermal noise power in watts, 'K' is the Boltzmann's constant which is $1.38 * 10^{-23} J/K$, 'Tn' is equivalent noise temperature and 'Bn' is the bandwidth. The noise temperature is calculated as illustrated in [12] by:

$$T_n = T_{ant} + T_o(F - 1) \quad (8)$$

Where ' T_{ant} ', is noise temperature of the antenna and 'F' is antenna noise figure in dB and ' T_o ' is temperature of source. Temperature of antenna and source are assumed to be as $27^{\circ}C$ [12].

The simulation is modeled in MATLAB environment in order to calculate the SER of APDCDM and TDM with both M-PSK and M-QAM modulation schemes. In MATLAB we used direct method for calculating the SER which means comparing the transmitted and received data (i.e., number of error/number of transmitted bits).

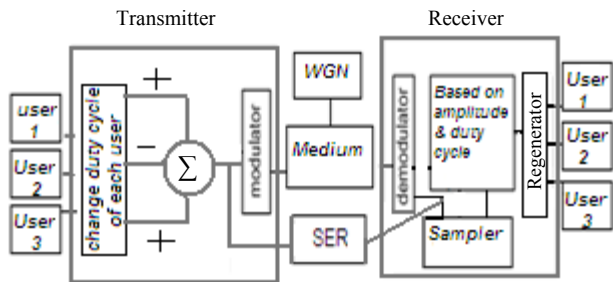

Fig.5. Block diagram of APDCDM

A. Simulation result

Two characteristics of multiplexing system are studied, first SER versus data rate, and second SER versus number of users. In the first case for Absolute polar duty cycle division multiplexing and TDM, numbers of multiplexing users are fixed for the simulation setup and data rate of each user varied from 1 to 20 Mbps. Two modulation schemes of M-PSK and M-QAM are used to modulate the output signal of the Absolute polar duty cycle division multiplexer.

Figure 6 shows the SER versus data rate of the absolute polar duty cycle division multiplexing for 16-PSK and 16-QAM modulation schemes. Based on this result, QAM present, better SER than PSK in different data rates.

The next comparison is done between absolute polar duty cycle division multiplexing and time division multiplexing techniques. In the case of comparison between different multiplexing schemes as QAM modulation scheme performs much better than PSK it is selected as the modulation scheme for comparison between APDCDM and TDM. Figure 7 shows the result of SER versus data rate. It showed that for all bit rates (4 -20 Mbps) the APDCDM has better performance than the TDM. Next comparison done based on number of users, in this case, the number of multiplexing users varied from 3 to 15. All users are assumed to transmit 10 Mbps and the distance between the transmitter and receiver as 10 Km. As illustrated in figure 8 the absolute polar duty cycle division multiplexing performed better than the TDM technique especially at the high number of users. This is because of the higher energy per bit of the absolute polar duty cycle division multiplexing signals as discussed in section (II.B). Base on the simulation results APDCDM has better SER than TDM

when we evaluate these techniques against data rate and number of users.

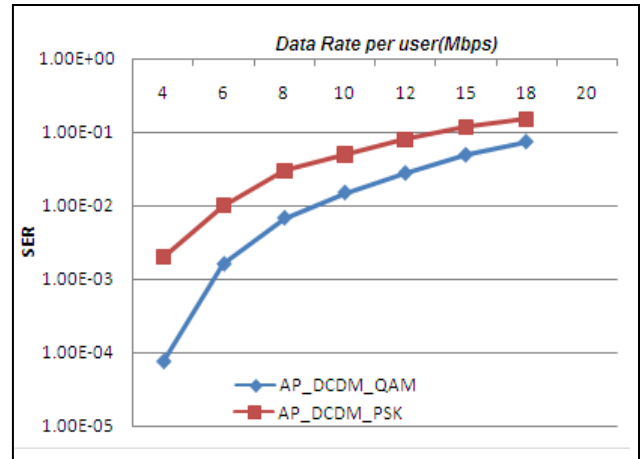

Fig.6. SER versus data rate for APDCDM using 16-PSK and 16-QAM

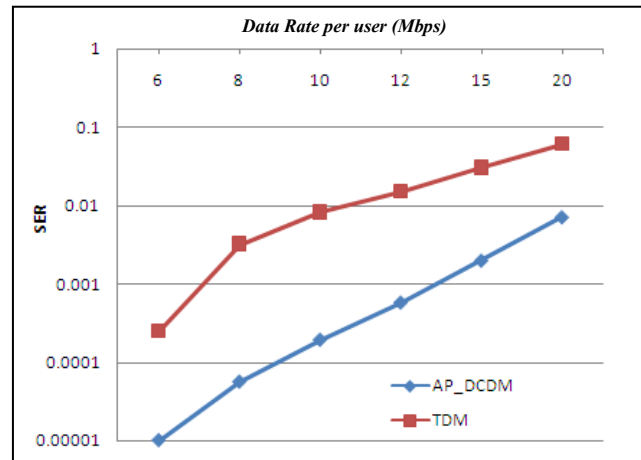

Fig.7. SER versus data rate for APDCDM and TDM using 8-QAM

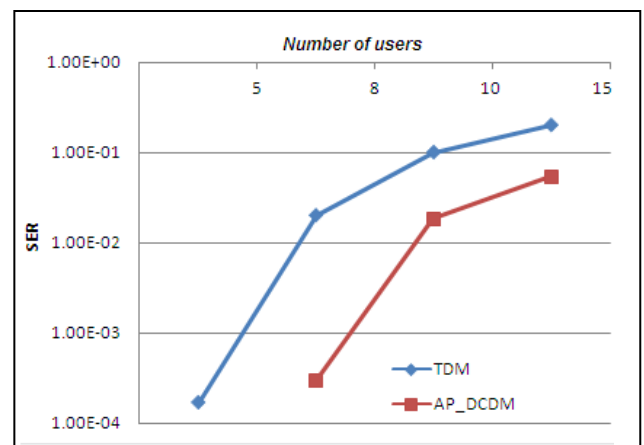

Fig. 8. SER versus number of users for APDCDM and TDM

IV. CONCLUSION

In this study, the principle of Absolute Polar Duty Cycle Division Multiplexing (APDCDM) technique is discussed by comparing with multilevel M-ary and TDM techniques.

Theoretical result showed that using the M-ary technique as multiplexing technique is impractical because the number of signal voltage levels is increased by 2^n (n is the number of users). Although TDM had the advantage of smaller amplitude levels, but by increasing the number of users the average energy per bit of APDCDM showed better performance compare to TDM technique. Simulation results clearly showed better performance of APDCDM than that of TDM for supporting higher number of multiplexing users and also bit rate. As we showed in the simulation result QAM modulation scheme presented better SER than PSK for APDCDM.

Although the simulation considers only noise and attenuation in communication media the generality of the transmission performance of absolute polar duty cycle division multiplexing in comparison with TDM is maintained. The other advantages of APDCDM technique consider for future reports are simpler transmission, better error detection, correction and better clock recovery.

REFERENCES

- [1] Wayne Tomas. Advanced Electronic Communications Systems 4th Edition, Prentice Hall PTR, Inc., USA, 1998.
- [2] Edmond zahedi, Digital Data communication: prentice-Hall, Inc Malaysia, 2002.
- [3] Jayalath, A.D.S.; Rajatheva, R.M.A.P.; Ahmed, K.M," Coded orthogonal frequency division multiplexing for wireless" *Vehicular Technology Conference, IEEE 49th* Volume 3, Issue, Jul 1999 Page(s):2049 - 2053 vol.3.
- [4] R. S. Tucker, G. Eisenstein, S. K. Korotky, "Optical time-division multiplexing for very high bit-rate transmission", *Journ. Lightwave Technology*, Volume 6, Issue 11, Nov. 1988, pp. 1737 – 1749
- [5] M. D. Spirit, A. D. Ellis, and P. E. Barnsley, "Optical time division multiplexing: Systems and networks," *IEEE Commun. Mag.*, vol. 32, no.12, pp. 56-62, Dec. 1994.
- [6] F. Babich, "Considerations on adaptive techniques for time-division multiplexing radio systems," *IEEE Trans. on Vehicular Tech.*, vol. 48,no. 6, pp. 1862-1873, Nov. 1999.
- [7] S. A. Aljunid, M. Ismail, A. R. Ramli, B. M. Ali, M. K. Abdullah, "A new family of optical code sequences for spectral-amplitude-coding optical CDMA systems", *Photon. Technol. Lett.*, Vol. 16, Issue 10, Oct. 2004, pp. 2383 – 2385.
- [8] J. A. Salehi, "Code division multiple-access techniques in optical fiber networks Parts I: Fundamental principles," *IEEE Trans. Commun.*, vol.37, pp. 824-833, Aug. 1989.
- [9] joseph c.palais. fiber optic communications,4th edition, Prentice Hall, Inc, USA, 1998.
- [10] M. K. Abdullah, M. F. Abdalla, A. F. Abas," Duty-cycle Division Multiplexing (DCDM): A Novel and Economical Optical Multiplexing and Electrical Demultiplexing technique for High Speed Fiber Optics Networks" *Wireless and Optical Communications Networks*, 2007.
- [11] G.A.Mahdiraji , M. Khazani.Abdullah ," Duty Cycle Division Multiplexing Technique for Wireless Communications " *Wireless and Optical Communications Networks*, Singapore, 2007.
- [12] T. S. Rappaport. Wireless communications: principles and practice. 2nd Edition, Prentice-Hall, Inc., USA, 2002.
- [13] Bahaa E.A.saleh, Maluin carl Teich. Fundamentals of photonics.:john wilay &sons. Inc 1994.
- [14] Harold kolimbiris. Digital communication systems with satellite and fiber optics applications. Prentice-Hall, Inc., USA 2000.
- [15] Purushotham Kamath, Joseph D. Touch and Joseph A. Bannister." The Need for Media Access Control in Optical CDMA Networks" Information Sciences Institute, University of Southern California.
- [16] Leon W.Couch II."Digitl and analog communication systems" Macmillan publishing company, Inc.USA.1993.