

## PDF hosted at the Radboud Repository of the Radboud University Nijmegen

The following full text is a publisher's version.

For additional information about this publication click this link.

<http://hdl.handle.net/2066/112583>

Please be advised that this information was generated on 2017-12-06 and may be subject to change.

# Two-dimensional electron gas in modulation-doped, ordered-disordered GaInP<sub>2</sub> homojunctions

F. A. J. M. Driessen, G. J. Bauhuis, P. R. Hageman, and L. J. Giling

Department of Experimental Solid State Physics, Research Institute for Materials, University of Nijmegen, Toernooiveld, NL 6525 ED Nijmegen, The Netherlands

(Received 13 April 1994; accepted for publication 27 May 1994)

Capacitance-voltage ( $C$ - $V$ ) profiling techniques and temperature-dependent Hall and resistivity measurements have been used to characterize modulation-doped ordered-GaInP<sub>2</sub>/disordered-GaInP<sub>2</sub> homojunctions grown by metalorganic vapor phase epitaxy. The  $C$ - $V$  measurements showed a narrow profile at the homointerface with an order of magnitude reduction in carrier density within 3 nm. Typical two-dimensional behavior was observed from Hall data showing sheet carrier densities as high as  $3.6 \times 10^{13} \text{ cm}^{-2}$  without carrier freeze out and constant mobilities around  $900 \text{ cm}^2 \text{ V}^{-1} \text{ s}^{-1}$  below  $T=100 \text{ K}$ . The 300 K channel conductivity of this new junction is  $3.2 \times 10^{-3} \Omega^{-1}$ , which is higher than reported in other two-dimensional electron gases.

The alloy Ga<sub>0.52</sub>In<sub>0.48</sub>P (hereafter: GaInP<sub>2</sub>) is of technological importance because it is lattice matched to GaAs, has a high band gap ( $\sim 1.9 \text{ eV}$  at room temperature), and exhibits various favorable properties such as the absence of  $DX$  centers.<sup>1</sup> Depending on the conditions of growth, the lowest free-energy state of GaInP<sub>2</sub> is either a random alloy (disordered) or shows CuPt-type ordering (monolayer superlattice ordering in the  $\langle 111 \rangle$  directions). The ordered state has a reduced band gap owing to the level repulsion between different symmetry states of the binary constituents. This reduction is predicted to be as high as 260 meV if the alloy is entirely ordered.<sup>2</sup> However, in practice only partial ordering into platelike domains occurs. Furthermore, only 2 out of the 4  $\langle 111 \rangle$  ordering variants occur; Friedman *et al.*<sup>3</sup> showed that this asymmetry occurs because the ordering facets are tilted  $4^\circ$  from  $(100)$  towards  $(111)_B$ . A variety of anomalous properties, predominantly at low  $T$ , have been reported for ordered GaInP<sub>2</sub>. These are caused by spatial separation of carriers<sup>4,5</sup> combined with the presence of quasi two-dimensional residual donors.<sup>6,7</sup> For electronic applications the two band-gap states of GaInP<sub>2</sub> offer challenging opportunities because band-gap engineering is possible by simply switching the conditions of growth. Because there is no change in materials or composition at the interface, the ordered and the disordered layers are automatically grown strain free. Along with the conservation of crystal symmetry, the number of nonradiative interface states is then expected to be lower than that of heterointerfaces. This should improve the electrical quality of the interface, as has indeed been observed recently.<sup>8</sup>

In this letter we present the first modulation-doped  $o$ (ordered)-GaInP<sub>2</sub>/ $d$ (disordered)-GaInP<sub>2</sub> homojunction, and characterize it by capacitance-voltage ( $C$ - $V$ ), resistivity, and Hall effect data in the temperature range 10–450 K.

The sample was grown by metalorganic vapor phase epitaxy at a pressure of 20 mbar with AsH<sub>3</sub>, PH<sub>3</sub>, trimethylgallium, and "solution-trimethylindium"<sup>9</sup> as precursors. The structure was grown on a  $(100)$   $6^\circ$  off towards  $(11\bar{1})$ , semi-insulating GaAs substrate, and consisted sequentially of a  $0.3 \mu\text{m}$  undoped GaAs buffer layer, a  $0.5 \mu\text{m}$  long-range ordered, undoped GaInP<sub>2</sub> layer (low band gap), and a

disordered-GaInP<sub>2</sub> layer (high band gap), in which a 5 nm undoped spacer layer was followed by a 100 nm uniformly  $n$ -doped layer with  $n=4 \times 10^{18} \text{ cm}^{-3}$ . Switching between the  $o$  and the  $d$  state was achieved by simultaneously increasing the growth temperature from 640 to 720  $^\circ\text{C}$  and decreasing the V-III ratio from 400 to 125 during a growth interruption. We selected only the  $(11\bar{1})$  ordering variant by using the aforementioned substrate.<sup>10,11</sup> Cross-sectional TEM micrographs of ordered GaInP<sub>2</sub> epilayers grown on these substrates<sup>12</sup> show that the ordered domains are thin in the  $32^\circ$  off towards  $[100]$  direction but extended, with rectangular shape, in the directions perpendicular thereto; the situation is elucidated in Fig. 1. The average dimensions of the domains are  $\bar{b}=3.5\text{--}6 \text{ nm}$  and  $\bar{c}=60 \text{ nm}$ ; that of  $\bar{a}$  is unknown because no ordering reflections are observed at  $(01\bar{1})$  cross sections. However, in a forthcoming publication we conclude that  $\bar{c} > \bar{a}$  from the angular dependence of mobility vs  $T$ .<sup>12</sup> A Hall bar was processed with drain-to-source contacts oriented in the  $[01\bar{1}]$  crystallographic direction. Hence, electrons move across the whole length  $c$  of an ordered

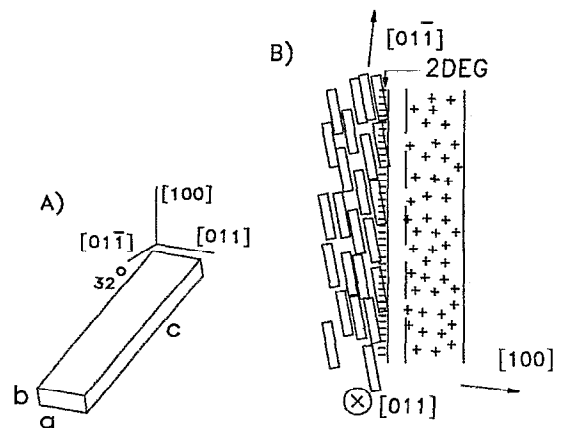

FIG. 1. (A) Orientation of the ordered domains;  $[100]$  is the direction of growth. The average values for  $b$  and  $c$  are 3.5–6 and 60 nm; further that of  $a$  is smaller than that of  $c$ . (B) Schematic of the anisotropic ordered state and the charge distribution in the sample.

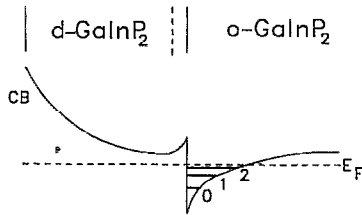

FIG. 2. Conduction-band structure of the *o-d* GaInP<sub>2</sub> modulation-doped homojunction.

plate-like domain before “transferring” to a neighboring domain. *C-V* measurements were performed in depletion mode at  $T=300$  K using a Polaron profiler. Hall and resistivity measurements were performed in a flow cryostat with temperature tuning between 10 and 450 K because at higher temperatures intrinsic conduction through the GaAs substrate influenced the measurements. The standard magnetic field in these experiments was 0.6 T.

The completely ordered alloy is known to have a band gap 260 meV lower than that of the random alloy. For inhomogeneous media like the (partially) *o-GaInP<sub>2</sub>* state it is difficult to maintain the concept of a band structure, which relies on the periodicity and infiniteness of the crystal. However, the onset of signal recorded with photoluminescence excitation spectroscopy<sup>13</sup> is fairly sharp for partially ordered samples and can be used as a measure of the band gap.<sup>14</sup> The conduction-band structure of the modulation-doped junction is shown in Fig. 2.

Although the classical theory for *C-V* measurements does not apply strictly to the 2D quantum mechanical system, the technique has proven valuable for these degenerate systems.<sup>15</sup> In modulation-doped heterostructures with no detectable parallel conductance, the depletion of the 2DEG during *C-V* profiling begins already at zero bias voltage, as can be seen for our sample in Fig. 3. The profile shows a high carrier density at the *d-GaInP<sub>2</sub>/o-GaInP<sub>2</sub>* interface, which decreases by one order of magnitude within 3 nm from the interface. Because of majority carrier diffusion, this distance

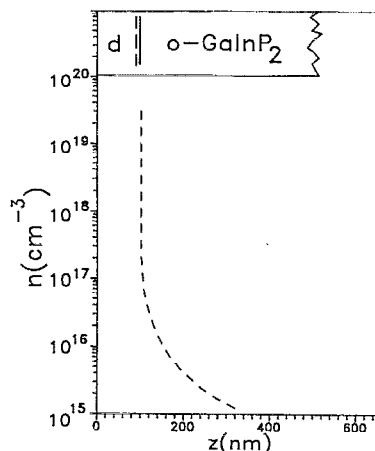

FIG. 3. Capacitance-voltage profile recorded at  $T=300$  K; the inset shows the sample structure.

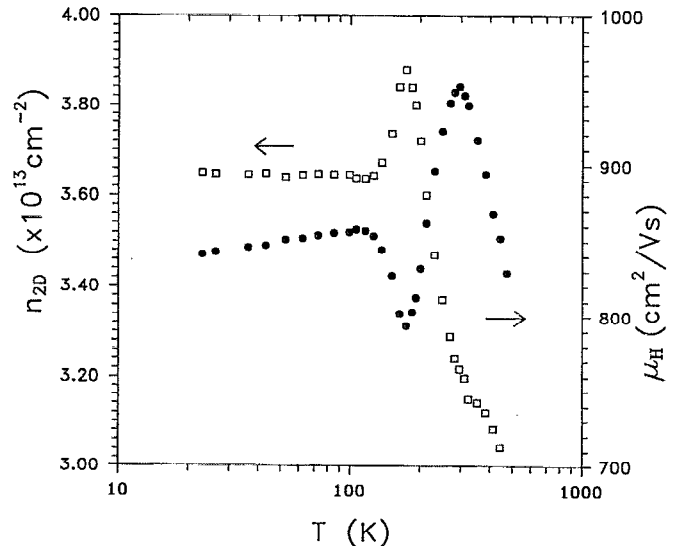

FIG. 4. Sheet carrier density and mobility vs temperature.

is an upper limit.<sup>16</sup> The strong spatial localization of the 2DEG is unambiguously shown here.

Figure 4 shows the sheet carrier density  $n_{2D}$  and the Hall mobility  $\mu_H$  as a function of temperature. No freeze out of carriers is observed below  $T=100$  K, which confirms the formation of a 2DEG, and an unprecedentedly high value of  $n_{2D}=3.6 \times 10^{13} \text{ cm}^{-2}$  is observed in this range. Upon increasing temperature the carrier concentration first increases, as has been observed earlier in 2D systems,<sup>17</sup> but then shows an unprecedented decrease. This decrease is not dramatic (at room temperature still an  $n_{2D}$  of  $2.0 \times 10^{13} \text{ cm}^{-2}$  remains) and is most probably caused by delocalization from the ordered domains, as previously reported in ordered GaInP<sub>2</sub> epilayers,<sup>6,7</sup> so that the conductive layer broadens slightly. It should be noted that the 2DEG is still strongly confined at the interface at 300 K because the *C-V* profile was taken at this temperature. To our knowledge, the above sheet carrier density is the highest reported in any III/V heterostructure; this includes  $\delta$ -doped samples, which are especially known for their high  $n_{2D}$ .<sup>18</sup> We infer a combination of reasons for this: The absence of carrier trapping *DX* centers in GaInP<sub>2</sub>; the previously mentioned reduction in nonradiative interface states owing to the homoepitaxy; and finally, the absence of Al in the sample, which reacts very quickly with residual traces of oxygen and water during growth, and thereby forms deep centers.<sup>19</sup>

The Hall mobility  $\mu_H$  has a constant value below  $T \approx 100$  K, it increases between 100 and 300 K, and shows a further decrease at higher  $T$ . The scattering mechanisms causing this behavior are “mesoscopic” interface roughness scattering, cluster scattering, and polar optical phonon scattering, for the respective temperature regimes.<sup>12</sup>

For high-speed operation of electronic devices the channel conductivity ( $\sigma_{ch}=en_{2D}\mu$ ) at room temperature must be maximized. In Table I the  $\sigma_{ch}$  for this GaInP<sub>2</sub> 2DEG is compared with that of 2DEGs in GaAs/AlGaAs, InGaAs/AlInAs, and  $\delta$ -FETs both at  $T=4.2$  and 300 K. Despite its lower value at low temperature, the  $\sigma_{ch}$  of *o-d* GaInP<sub>2</sub> surpasses

TABLE I. Channel conductivities  $\sigma_{\text{ch}}$  for 2DEGs in various systems at  $T=4$  and 300 K.

	$\sigma_{\text{ch}}^4 \text{K} (\Omega^{-1})$	$\sigma_{\text{ch}}^{300 \text{K}} (\Omega^{-1})$
<i>o-d</i> GaInP <sub>2</sub>	$5.0 \times 10^{-3}$	$3.2 \times 10^{-3}$
GaAs/AlGaAs <sup>a</sup>	$1.1 \times 10^{-1}$	$1.1 \times 10^{-3}$
InGaAs/AlInAs <sup>b</sup>	$9.4 \times 10^{-3}$	$9.4 \times 10^{-4}$
$\delta$ FET <sup>c</sup>	$1.3 \times 10^{-3}$	$9.6 \times 10^{-4}$

<sup>a</sup>From Ref. 20.

<sup>b</sup>From Ref. 21.

<sup>c</sup>From Ref. 18.

those of the others at 300 K. This remarkably high value is caused by the  $\mu(T)$  behavior and makes the *o-d* GaInP<sub>2</sub> 2DEG suited for application in electronic devices. A further increase of  $\sigma_{\text{ch}}$  can be expected if spacer thicknesses of  $\sim 30$  nm are used.<sup>20</sup>

In conclusion, we have prepared and characterized the first two-dimensional electron gas in modulation-doped *o*-GaInP<sub>2</sub>/*d*-GaInP<sub>2</sub> homojunctions. Temperature-dependent Hall and resistivity measurements revealed 2D behavior with an extremely high sheet carrier concentration of  $n_{2\text{D}} = 3.6 \times 10^{13} \text{ cm}^{-2}$  and constant mobility around  $900 \text{ cm}^2 \text{ V}^{-1} \text{ s}^{-1}$  below  $T=100$  K. A sharp *C-V* profile at the *o-d* interface confirmed the dense 2DEG. Finally, the system exhibits the highest channel conductivity at  $T=300$  K reported so far and is therefore suited for the fabrication of high-speed electronic devices.

Financial support from the Stichting voor Fundamenteel Onderzoek der Materie (FOM) and the Nederlandse Organisatie voor Energie en Milieu (NOVEM) is gratefully acknowledged, as is D.M. Frigo for critically reading the manuscript.

- <sup>1</sup>D. Costa and J. Harris, Jr., IEEE Trans. Electron. Devices **59**, 2383 (1992).
- <sup>2</sup>S.-H. Wei and A. Zunger, Appl. Phys. Lett. **56**, 662 (1990).
- <sup>3</sup>D. J. Friedman, J. G. Zhu, A. E. Kibbler, J. M. Olson, and J. Moreland, Appl. Phys. Lett. **63**, 1774 (1993).
- <sup>4</sup>J. E. Fouquet, V. M. Robbins, J. Rosner, and O. Blum, Appl. Phys. Lett. **57**, 1566 (1990).
- <sup>5</sup>M. C. DeLong, W. D. Ohlsen, I. Viohl, P. C. Taylor, and J. M. Olson, J. Appl. Phys. **70**, 2780 (1991).
- <sup>6</sup>F. A. J. M. Driessen, G. J. Bauhuis, S. M. Olsthoorn, and L. J. Giling, Phys. Rev. B **48**, 7889 (1993).
- <sup>7</sup>G. J. Bauhuis, F. A. J. M. Driessen, and L. J. Giling, Phys. Rev. B **48**, 17239 (1993).
- <sup>8</sup>R. A. J. Thomeer, A. van Geelen, and L. J. Giling (unpublished).
- <sup>9</sup>D. M. Frigo, W. W. van Berkel, W. A. H. Maassen, G. P. M. van Mier, J. H. Wilkie, and A. W. Gal, J. Cryst. Growth **124**, 99 (1992).
- <sup>10</sup>P. Bellon, J. P. Chevalier, E. Augard, J. P. André, and G. P. Martin, J. Appl. Phys. **66**, 2388 (1989).
- <sup>11</sup>A. Gomyo, S. Kawata, T. Suzuki, S. Iijima, and I. Hino, Jpn. J. Appl. Phys. **10**, L1728 (1989).
- <sup>12</sup>F. A. J. M. Driessen, G. J. Bauhuis, P. R. Hageman, A. van Geelen, and L. J. Giling (unpublished).
- <sup>13</sup>M. C. DeLong, D. J. Mowbray, R. A. Hogg, M. S. Skolnick, M. Hopkinson, J. P. R. David, P. C. Taylor, S. R. Kurtz, and J. M. Olson, J. Appl. Phys. **73**, 5163 (1993).
- <sup>14</sup>The photon energy of PL signal is no measure of the band gap because it strongly depends on impurities, depletion fields, and band-filling effects.
- <sup>15</sup>E. F. Schubert, K. Ploog, H. Dämbkes, and K. Heime, Appl. Phys. A **33**, 63 (1984).
- <sup>16</sup>D. V. Lang, R. A. Logan, and M. Jaros, Phys. Rev. B **19**, 1015 (1979).
- <sup>17</sup>R. Dingle, H. Störmer, A. Gossard, and W. Wiegmann, Appl. Phys. Lett. **33**, 665 (1978).
- <sup>18</sup>N. Pan, J. Carter, G. S. Jackson, H. Hendriks, J. C. Huang, and X. L. Zheng, Inst. Phys. Conf. Ser. **112**, 401 (1990).
- <sup>19</sup>J. Zhang, B. M. Keyes, S. E. Asher, R. K. Ahrenkiel, and M. L. Timmons, Appl. Phys. Lett. **63**, 1369 (1993).
- <sup>20</sup>W. Walukiewicz, H. E. Ruda, J. Logowski, and H. C. Gatos, Phys. Rev. B **30**, 4571 (1984).
- <sup>21</sup>A. Kastalsky, R. Dingle, K. Y. Cheng, and A. Y. Cho, Appl. Phys. Lett. **41**, 274 (1982).