

**Transactions of the VŠB – Technical University of Ostrava, Mechanical Series**

No. 2, 2017, vol. LXIII

article No. 2036

**Piotr OSTROWSKI\*, Marek PRONOBIS**

COGENERATION CYCLE IN WATER HEATING BOILERS

KOGENERAČNÍ CYKLY VE VODOTRUBNÝCH KOTLECH

**Abstract**

Cogeneration – joint generation of electricity and heat brings savings in consumption of primary fuels. Therefore, it contributes to reduction of harmful substances emission to the atmosphere (CO<sub>2</sub> emission), which also means reduction of external costs of energy and heat generation. Until present, the cogeneration cycles have not been used in heating plants equipped with water boilers (in particular the water-tube ones). This paper presents a concept of innovative cogeneration cycle which operates with a water heating or industrial boiler. The cogeneration cycle does not change the approval of technical parameters of the boiler and it does not limit the scope of its use. The developed comparative cycles in the h-s and T-s systems and simulation model of the unit cogeneration cycle are presented as diagrams and cogeneration indicators. Furthermore, economic indicators of cogeneration are presented for water boilers.

**Abstrakt**

Kogenerace - společná výroba elektřiny a tepla přináší úspory spotřeby primárních paliv. Proto přispívá ke snížení emisí škodlivých látek do ovzduší (emise CO<sub>2</sub>), což také znamená snížení externích nákladů na výrobu energie a tepla. Dosud nebyly kogenerační cykly používány v teplárnách s parními kotly (zejména vodotrubnými). Tento článek představuje koncept inovačního kogeneračního cyklu, který pracuje s ohřevem vody u průmyslového kotle. Kogenerační cyklus nemění schválené technické parametry kotle a neomezuje rozsah jeho použití. Vyvinuté srovnávací cykly v systémech h-s a T-s a simulační model kogeneračního cyklu jednotky jsou prezentovány jako diagramy a ukazatele kogenerace. Dále jsou představeny ekonomické ukazatele kogenerace pro vodotrubné kotle.

**Keywords**

cogeneration, CHP, water boilers, cogeneration efficiency indicators

**1 INTRODUCTION**

In Poland, the energy-effective heating system means a heating or cooling system in which to generate heat or cold the following is used as a minimum:

- a) 50% energy from renewable energy sources or
- b) 50% waste heat, or
- c) **75% cogeneration heat**, or
- d) 50% combination of energy and heat referred to in items a–c.

\* Division of Boilers and Steam Generators, Silesian University of Technology Konarskiego 20, 44-100 Gliwice, Poland, +48 032 237 23 79 email: piotr.ostrowski@polsl.pl

**Cogeneration (or Combined Heat and Power CHP)** is the simultaneous generation of heat and electrical or mechanical energy in the same technological process (*i.e. in combination*).

**High-efficiency cogeneration** means generation of electrical or mechanical energy and useful heat in cogeneration which ensures saving of primary energy used in:

- a) cogeneration unit in the minimum quantity of 10% in comparison to generation of electrical energy and heat in separate systems (of referential efficiency values for separate generation)
- b) cogeneration unit of the installed capacity not exceeding 1 MW in comparison to generation of electrical energy and heat in separate systems (of referential efficiency values for separate generation).

**Electrical energy produced in cogeneration**

Electrical energy produced in cogeneration is calculated as the product of coefficient and annual quantity of useful heat in cogeneration that was generated with annual average efficiency of chemical energy conversion into energy (electrical or mechanical and useful heat) in cogeneration lower than limit efficiencies. This coefficient is calculated on the basis of measurements of the cogeneration unit technological parameters for a specific interval of time and it defines the relationship of electrical energy from cogeneration to the useful heat in cogeneration.

In Poland, combined or industrial power and heat plants which are equipped with coal (or gas) steam boilers and steam turbines operate in the cogeneration system - Fig. 1.

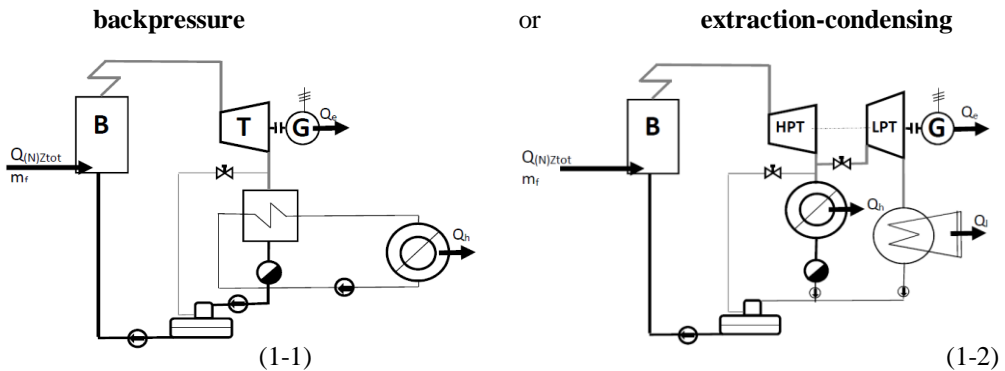

In recent years, cogeneration systems with **gas turbines** or **gas and steam turbines** equipped with furnace-free boilers **water** or **steam** have been put into operation.

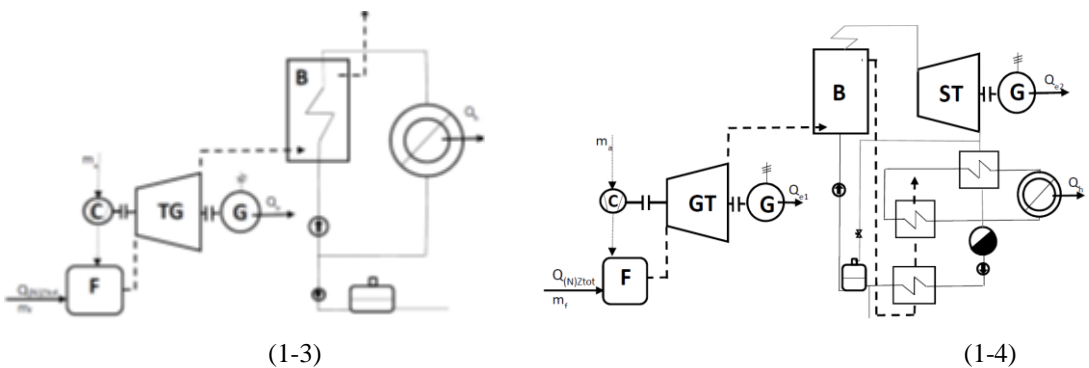

**Fig. 1** Diagrams of typical cogeneration cycles

Energy production in CHP gives the opportunity to reduce consumption of primary fuels. Therefore, it contributes to reduction of harmful substances emission to the atmosphere (also CO<sub>2</sub> emission), which also means reduction of external costs of energy and heat generation.

Promotion of cogeneration is the deviation made by the European Union from the adopted competition promoting policy and it enables application of new mechanisms to support high-efficiency technologies.

Until present, the cogeneration cycles have not been used in heating plants equipped with water boilers (in particular the water-tube ones). This paper presents a concept of innovative cogeneration cycle which operates with a district heating or industrial boiler. The cogeneration cycle does not change the approval of the technical parameters of the boiler and it does not limit the scope of its use.

## 2 DESCRIPTION OF COGENERATION IN WATER HEATING BOILERS

[PATENT APPLICATION P.421821]

Innovative cogeneration plant is designed for heating plants equipped with water boilers (in particular the water-tube ones) and it produces heat and electric energy in cogeneration.

Coal fuel fired in the water boiler furnace heats up the circulating water to the temperature of approx. 20°C higher than the nominal temperature of approx. 150°C, however, lower than the saturation temperature of 201.5 °C (arising from the pressure in water circulation system; approx. 1.6 MPaa). Circulation water behind the boiler (1.6 MPaa, 165°C) is throttled in an isenthalpic process by a valve to the nominal temperature of water behind the boiler < 150°C and it feeds the heating system.

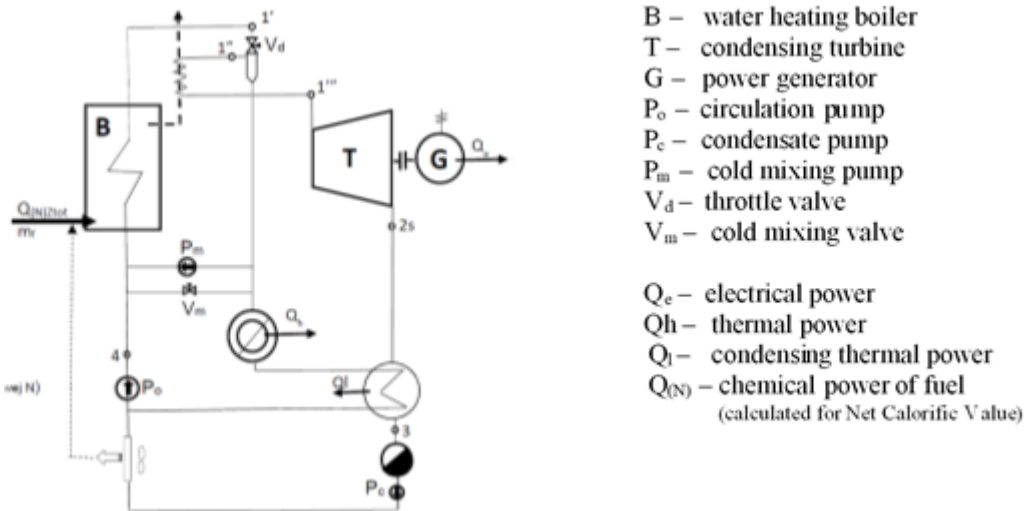

**Fig. 2** Cogeneration plant for water-tube district heating boilers

The dry saturated steam generated in the isenthalpic throttling process of the ≤ 150°C unit temperature is in the superheater heated up by the flue gas stream to the temperature of ≤ 400°C; and the superheater connections on the flue gases side bridge the water heater in the 2nd boiler line. The superheated steam feeds the steam condensing turbine which generates power for the power generator drive. Electrical energy produced by the generator is used in the in-house network or it is distributed to the public network.

The return water from the external heating system is sent to cool down the wet steam in the condenser behind the condensing turbine. The condensate temperature is similar to the seasonally changing

temperature of approx. 42 – 48°C of the return heating water. The condensate of 45 – 50°C temperature (option after additional cooling of air in combustion heaters or seasonally also air from the intake) comes back to the return water in the boiler circulation before cold and hot intermixture.

### 3 COMPARATIVE CHP CYCLES IN WATER HEATING BOILERS

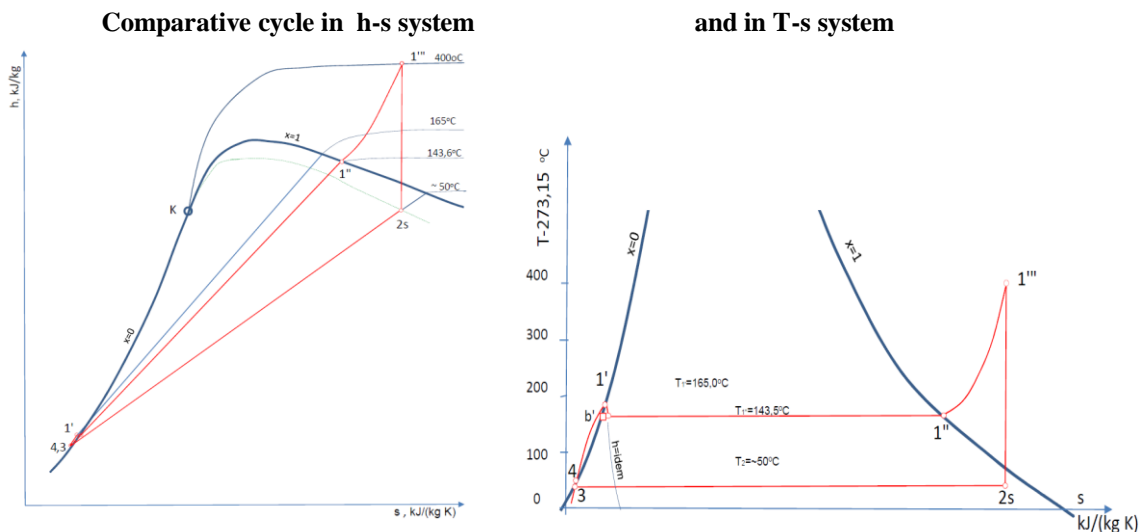

Fig. 3 Comparative cogeneration cycles in water-tube district heating boiler

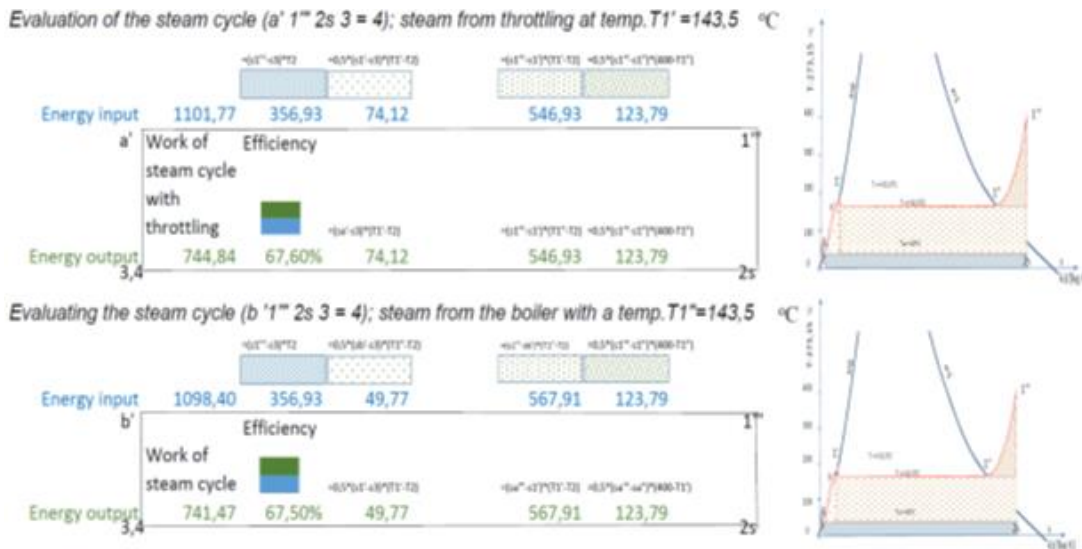
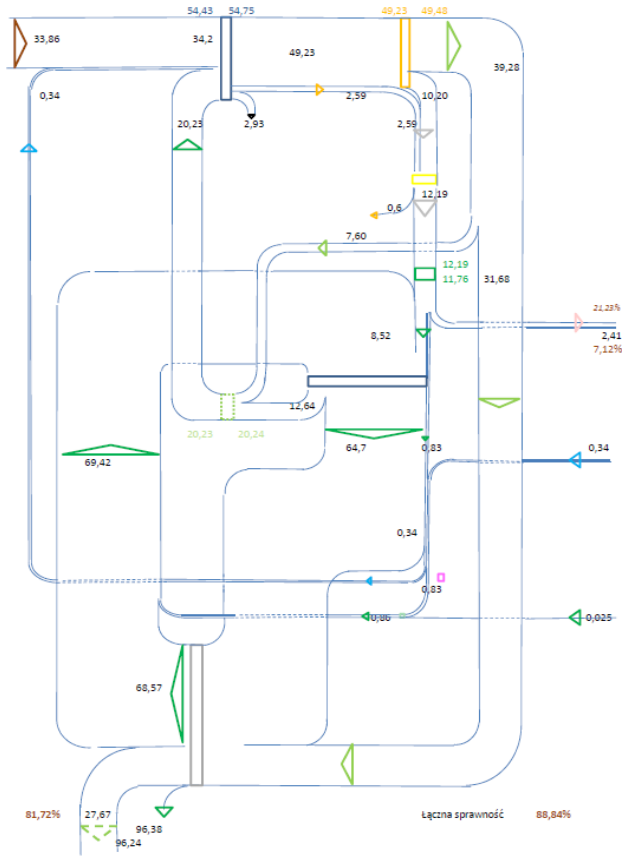

Fig. 4 Comparison of cycles

### 4 RESULTS

Computer simulations of cogeneration cycle were made for WR8 to WR25 water-tube water heating boilers and selected results of these simulations are presented on Fig. 5 and 6 and in Table 1.



**Fig. 5** Sankey diagram of energy

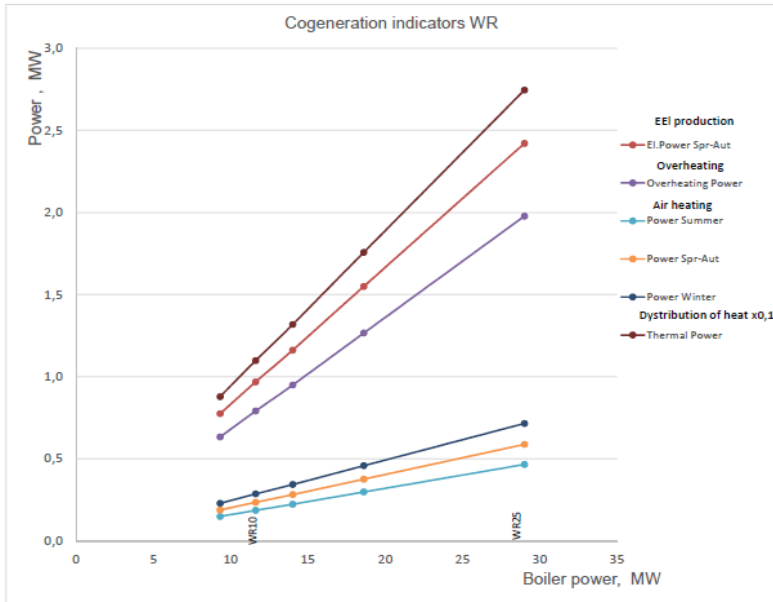

**Fig.6** Thermal indicators of cogeneration for WR boilers

**Tab.1** Economic indicators of cogeneration for WR boilers

	Boiler load	%		100%	100%	100%	
	Chemical power of fuel	MW		34.18	34.36	34.52	
	Number of hours/y			2,150	4,300	2,150	
		Power, MW	Unit	Summer	Spr.-Aut.	Winter	Σ
	Price		PLN	PLN	PLN	PLN	PLN
1	Chemical energy of fuel		45.82	3,367,484	6,769,005	3,400,909	13,537,398
2	Distributed heat	29.00	92.74	5,782,090	11,564,179	5,782,090	23,128,358
	(2:1)						170.85%
3	Distributed heat	27.752	92.74	5,533,180	11,066,361	5,533,180	
4	Electric power consumed	0.50	313.8	337,335	674,670	337,335	
5	Electric power sold	1.912	150	616,527	1,233,054	616,527	
6	Sum (3:5)			6,487,043	12,974,085	6,487,043	25,948,170
	(6:1)						191.68%
7	Profit from modernisation (6) - (2)						<b>2,819,812</b>
8	Cost of investment (estimated)						<b>5,377,500</b>
9	Simple period of return (8:7) (years)						<b>1.91</b>

## 5 SUMMARY

In case of constant fuel consumption:

- in WR25 boiler without cogeneration the 29.0 MWt thermal power is generated if heating plant efficiency is ~ 84% boiler efficiency
- in cogeneration unit (WR25 boiler with cogeneration) 27.75 MWt thermal power and 2.41 MWe electrical power are generated with the cogeneration coefficient  $f_c = 2.41/27.75=0.087$  and heating plant efficiency is ~ 88.84% > 80% of cogeneration efficiency which satisfies the prerequisite for electrical energy production in cogeneration and filing an application for obtaining **red certificates**.

Use of waste energy (1.95MWt flue gases heat and 8.75 MWt condensate heat) creates conditions for filing an application for obtaining **white certificates**.

Economic comparison of cogeneration and heat plant efficiency:

- income on sales of heat/ fuel costs = 170.85%
- (income on sales of heat + costs of electrical energy avoided) / fuel costs 191.68%

Estimated simple period of return of the expenditures on modernisation is 1.91 years.

## REFERENCES

- [1] SZARGUT J. Termodynamika techniczna, Wyd. Politechniki Śląskiej Gliwice 2000 ISBN 83-85718-67-2,
- [2] OSTROWSKI P., PRONOBIS M., Et Al. Zgłoszenie patentowe P.421821 Sposób i instalacja kogeneracji w ciepłowniach zwłaszcza wyposażonych w kotły wodnorurowe. (N-ergia) 06.06.2017.