

University of Bath



**PHD**

**Design and synthesis of novel antioxidants**

Wood, Virginia Ann

*Award date:*  
1999

*Awarding institution:*  
University of Bath

[Link to publication](#)

**General rights**

Copyright and moral rights for the publications made accessible in the public portal are retained by the authors and/or other copyright owners and it is a condition of accessing publications that users recognise and abide by the legal requirements associated with these rights.

- Users may download and print one copy of any publication from the public portal for the purpose of private study or research.
- You may not further distribute the material or use it for any profit-making activity or commercial gain
- You may freely distribute the URL identifying the publication in the public portal ?

**Take down policy**

If you believe that this document breaches copyright please contact us providing details, and we will remove access to the work immediately and investigate your claim.

Download date: 13. May. 2019

Design and Synthesis of Novel Antioxidants

Submitted by Virginia Ann Wood

For the degree of PhD

Of the University of Bath

1999

COPYRIGHT

Attention is drawn to the fact that copyright of this thesis rests with its author. This copy of the thesis has been supplied on condition that anyone who consults it is understood to recognise that its copyright rests with its author and that no quotation from the thesis and no information derived from it may be published without the prior written consent of the author.

This thesis may be made available for consultation within the University Library and may be photocopied or lent to other libraries for the purpose of consultation.



UMI Number: U117664

All rights reserved

INFORMATION TO ALL USERS

The quality of this reproduction is dependent upon the quality of the copy submitted.

In the unlikely event that the author did not send a complete manuscript and there are missing pages, these will be noted. Also, if material had to be removed, a note will indicate the deletion.



UMI U117664

Published by ProQuest LLC 2013. Copyright in the Dissertation held by the Author.  
Microform Edition © ProQuest LLC.

All rights reserved. This work is protected against  
unauthorized copying under Title 17, United States Code.



ProQuest LLC  
789 East Eisenhower Parkway  
P.O. Box 1346  
Ann Arbor, MI 48106-1346

UNIVERSITY OF BATH LIBRARY		
30	22 MAR 2000	
Ph.D.		

## Contents

Acknowledgements	
Abbreviations	
Summary	
Background	1
1.0 Introduction:	1-23
1.1 Cholesterol and Atherosclerosis	1
1.2 Transport of Cholesterol in the body	2-5
1.3 LDL receptors	6
1.4 Receptor-Mediated Clearance of LDL	6-7
1.5 Formation of an atherosclerotic plaque by LDL	8-10
1.6 Lipid Peroxidation	11-14
1.7 Autoxidation and Antioxidants	15-16
1.8 Vitamin E	16-18
1.9 Previous Research	18-23
2.0 The Carbazoles	24-49
3.0 Single electron transfer as a mechanistic feature in the alkylation/addition reactions of indolenines	50-61
3.1 Electrochemistry of imines: an introduction	62-71
3.2 Electrochemistry of imines: Results	72-86
4.0 Piperidinotetrahydroquinolines	87-100
5.0 The Imidazolidines	101-112
6.0 Experimental	113-171
7.0 References	172-178

## Acknowledgements

Firstly I would like to express my gratitude to my supervisor Prof. Malcolm Sainsbury for his support and advice during the period of my research work at Bath and for the time he has spent reading through the entire manuscript of my thesis. I would also like to thank all the technical and general support of the University of Bath.

A big thank you also goes to Dr Max Liu, Dr Ali Ninan, Dr Dave Brown, Dr Neil Smith, and Dr Lawrence Ho for their initial support when I started at Bath.

Finally I would like to thank the following people for making my life at Bath one to remember: Ambrose (who managed to live with me for 3 years!), JC and Tiny T for providing with me regular stress relief on the squash court, The maths posy especially Stu and Steve "yeah, yeah, yeah, check it out nice one"!), Eric (Wild Bill!) (for fixing my computer), Jen, Gail (bird), Nindie for his witty emails, Mr Mendonca (the dancing queen), Selma alabama (Dolly), Christelle (1+2), Mark (profit), Gian (the purple gnome), all my work colleagues at Eli Lilly Research,

and last but not least Mr Gumboo (goozy) for all his love and support throughout my final year and writing up period.

## Abbreviations

ACAT:	enzyme cholesterol acyl transferase
AIBN:	2,2 <sup>1</sup> -azobisisobutyronitrile
BOC, <i>t</i> -BOC	<i>tert</i> -butoxycarbonyl
CoA:	coenzyme A
DCC:	1,3-dicyclohexylcarbodiimide
DCM:	dichloromethane
DCU:	<i>N,N</i> -dicyclohexylurea
Dibal-H:	diisobutylaluminium hydride
DMAP:	4- <i>N,N</i> -dimethylaminopyridine
DMF:	<i>N,N</i> -dimethylformamide
DMSO:	dimethyl sulfoxide
EDC, EDCI	1-[3-( <i>N,N</i> -dimethylaminopropyl)]-3-ethylcarbodiimide hydrochloride
e:	electron
HMG-CoA	$\beta$ -hydroxy- $\beta$ methylglutaryl CoA
HOBt:	1-hydroxybenzotriazole hydrate
IR:	infrared spectroscopy
NBS:	<i>N</i> -bromosuccinimide
NMR:	nuclear magnetic resonance
Nuc:	nucleophile
PCC:	pyridinium chlorochromate
SET:	single electron transfer

TFA: trifluoroacetic acid  
THF: tetrahydrofuran  
TLC: thin layer chromatography  
TMEDA: *N,N,N',N'*-tetramethylethylenediamine  
TMS: trimethylsilyl  
trityl: triphenylmethyl



## Summary

The work in this thesis was undertaken between October 1996 and August 1999 and is primarily concerned with the design and synthesis of novel antioxidants. These compounds could prove useful in the treatment of conditions such as atherosclerosis and diabetes where lipid peroxidation plays an important role.

The syntheses of some novel carbazoles and piperidinotetrahydroquinolines are described. An important step encountered throughout the course of the research involves the addition of alkyl lithiums to indoleines. The reaction was thus studied using a variety of nucleophiles with particular reference to the selectivity of the additions. Evidence was gained to believe that this may not be a simple two electron but rather a single electron transfer.

Attention was then turned to electrochemistry in an attempt to try and mimic the results obtained by chemical reduction of alkali metals.

The final part of the thesis involves the synthesis of some compounds where the problems of chirality have been eliminated.

## **Background**

Free radicals of various types are responsible for a broad range of diseases such as atherosclerosis and diabetes. One possible explanation for the induction of these diseases is that the endogenous antioxidants, which normally protect against radical damage, are not sufficiently active to prevent tissue impairment. Lipid peroxidation caused by the generation of excess radical species may constitute one significant damaging pathway in the above diseases. Administration of antioxidants (additional to those from dietary intake) are currently of interest since they may act to supplement and improve natural protection against attack by radical species such as superoxide<sup>1-3</sup>.

## 1.0 Introduction

### 1.1 Cholesterol and Atherosclerosis

Since its isolation, from gall stones in 1784, cholesterol (1) has become of great importance medically. On the one hand it is fundamental to mammalian existence, but on the other hand it has an association with heart disease.

Cholesterol is a hydrophobic steroid; it has one hydroxy group and one double-bond, together with a side chain of eight carbon atoms.

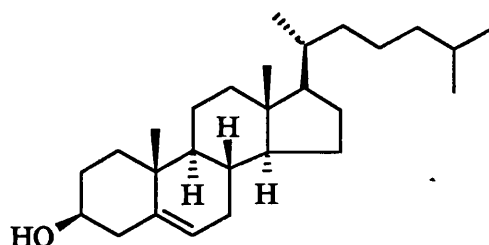

(1)

Cholesterol serves several vital functions in the body. It is an essential component of all cell membranes, providing stability and allowing for transmembrane transport. It is important in the biosynthesis of bile acids, which are produced in the liver and participate in the absorption of fat in the intestine.

### 1.2 Transport of cholesterol in the body

Cholesterol is highly insoluble in aqueous systems and for this reason it cannot circulate freely in plasma. Instead, it is transported around the body in complex particles called lipoproteins.

The basic structure of all lipoproteins are similar. They all contain a core of neutral lipids consisting of cholesterol esters and triglycerides and are surrounded by a surface coat of more polar lipids, which include unesterified cholesterol,

phospholipids and proteins known as apoproteins. The surface coat of the lipoproteins provides a covering structure that resembles the typical plasma membrane of cells, within this the lipids serve as an interface between the aqueous plasma and the inner non-polar lipid core. The lipoprotein is therefore soluble in aqueous media such as serum and can be transported around the circulatory system to areas of the body where it is required.

There are five distinct types of lipoprotein. Each lipoprotein is made up of a different combination of fats and proteins. All five lipoproteins have special functions, with different significance for the formation of arterial plaques and the development of coronary heart disease (CHD).

- **Chylomicrons.**

The transport of cholesterol from the intestine to the liver is facilitated by lipoproteins called chylomicrons. These particles are synthesized in the mucosal cells of the intestine, and are then transported through the lymphatic system until they reach the thoracic duct, where they drain into the bloodstream. Here, the triacylglycerol components are hydrolysed by the enzyme lipoprotein lipase and are either taken up by adipose tissue for storage, or by muscle tissue for oxidation to supply energy. The cholesterol enriched chylomicron remnants are then removed from circulation by liver cells.

- **Very low density lipoprotein (VLDL).**

The major lipoprotein synthesized by the liver is VLDL. VLDL particles transport endogenously produced triglycerides and some cholesteryl esters from the liver. VLDL remnants are either taken up by the liver or transformed into low density lipoproteins (LDL).

- **Intermediate density lipoprotein (IDL).**

When VLDL particles reach adipose or muscle tissue triglycerides are released, leaving a particle decreased in size, but enriched in cholesteryl esters. These residual assemblies are called IDLs. Approximately half of the IDLs in circulation are removed 2 - 6 hours after their initial formation by liver cells. Within these cells, cholesterol is extracted to make new VLDLs and bile acids. IDLs not taken up by the liver dissociate to form LDL particles.

- **High density lipoproteins (HDL).**

HDL units are responsible for the transport of cholesterol from the tissues back to the liver. This is achieved by converting the steroid into cholesteryl esters, some of which are taken up by the mobile VLDLs and some absorbed directly by the liver.

- **Low density lipoprotein (LDL).**

In human blood, the major cholesterol-carrying lipoprotein of plasma is LDL. A conjectural structure of a LDL particle is shown in [Figure (1)]. It consists of a lipid core composed of about 1500 molecules of cholesterol esters. The surface coat of LDL contains unesterified cholesterol and phospholipids together with a single apoprotein apo B-100. LDL can be removed from the bloodstream either *via* the liver or extrahepatic tissues. Uptake of LDL by either route can occur by both receptor and non-receptor pathways, although the latter are poorly defined.

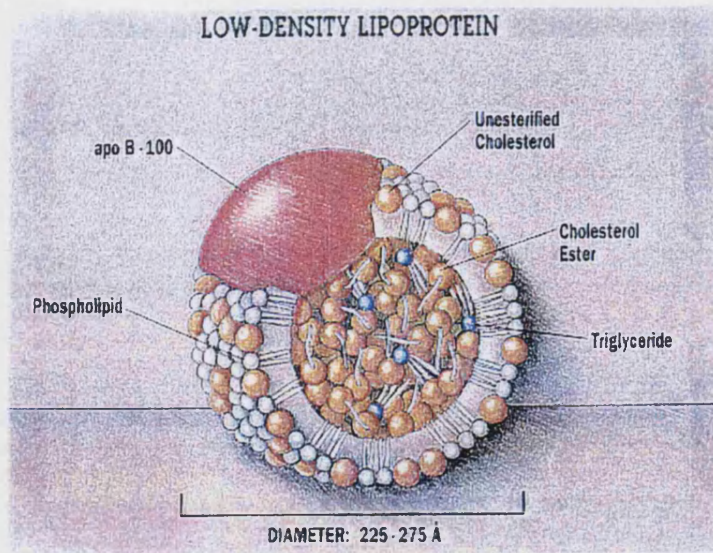

Figure (1). Reproduced by permission from S.M. Grundy, Cholesterol and Atherosclerosis, 1<sup>st</sup> ed., Gower Medical Publishing, New York, 1990 ©.

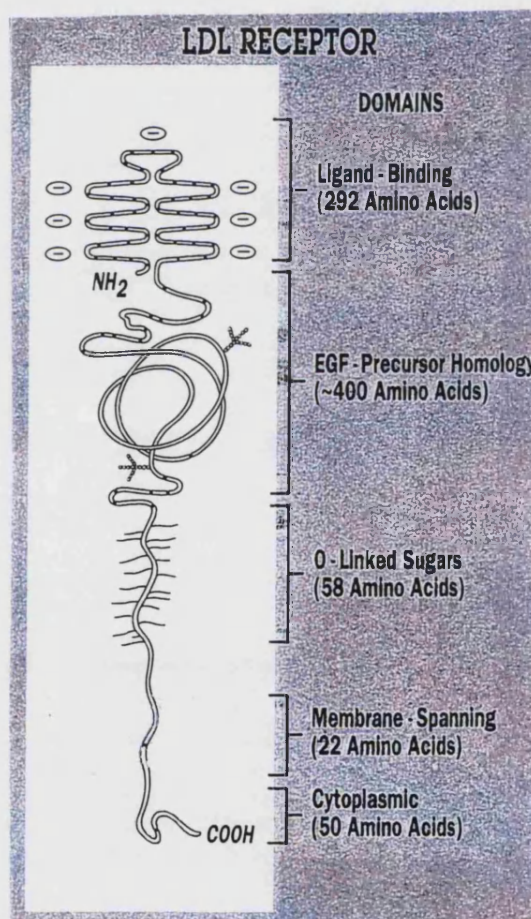

Figure (2). Reproduced by permission from S.M. Grundy, Cholesterol and Atherosclerosis, 1<sup>st</sup> ed., Gower Medical Publishing, New York, 1990 ©.

### **1.3 LDL receptors**

LDL receptors were first discovered in 1973 by Brown and Goldstein<sup>4</sup> when they were studying tissue cultures of the human skin cells called fibroblasts. Although, the actual structure of the LDL receptor is still a matter of some debate, a schematic representation can be made [Figure (2)]. The LDL receptor consists of 820 amino acids and a series of carbohydrate units with a total molecular weight in the region of 120,000. The receptor has been shown to possess several domains, each of which has a unique function. Only one domain is responsible for binding LDL to the plasma membrane of the cell. The central role of the LDL receptor in atherosclerosis was first appreciated when Goldstein and Brown showed that its absence is responsible for the severe disease called familial hypercholesterolemia (FH).

### **1.4 Receptor-Mediated Clearance of LDL**

The pathway by which fats are metabolized and transported around the body is very complex. However, the mechanism by which LDL is metabolized was finally elucidated in 1985 by Brown and Goldstein; an achievement for which they received a Nobel prize<sup>4</sup>.

The mechanism of LDL uptake by cells is shown in [Figure (3)]. LDL receptors are located in coated pits on the surface of cell membranes. When they bind to a LDL particle, the cell membrane fuses in the area of the LDL-receptor complex to form membrane bound sacs. These are then delivered to lysosomes, which contain digestive enzymes that hydrolyze the apoprotein components into amino acids, and the cholesteryl esters to free cholesterol. The receptor is then transferred back to

the cell membrane for further use. Most of the liberated cholesterol moves to the endoplasmic reticulum, where it is used for membrane synthesis. An accumulation of cholesterol has three regulatory effects:

- i) It reduces the synthesis of cholesterol by the cell by inhibiting the action of 3-hydroxy-3-methylglutaryl coenzyme A (HMG-CoA), and also by suppressing the synthesis of this enzyme itself.
- ii) It activates the enzyme acyl-CoA : cholesterol acyl transferase (ACAT), which attaches fatty acid chains to excess cholesterol to form cholesteryl esters. These are then deposited in storage droplets.
- iii) The most significant effect that an accumulation of cholesterol has is the inhibition of LDL receptor synthesis by the cell. The cell thus adjusts so that it has enough receptors to get the cholesterol it requires, but not so many as to overload it. Excess cholesterol is therefore left in the bloodstream in the form of LDLs.

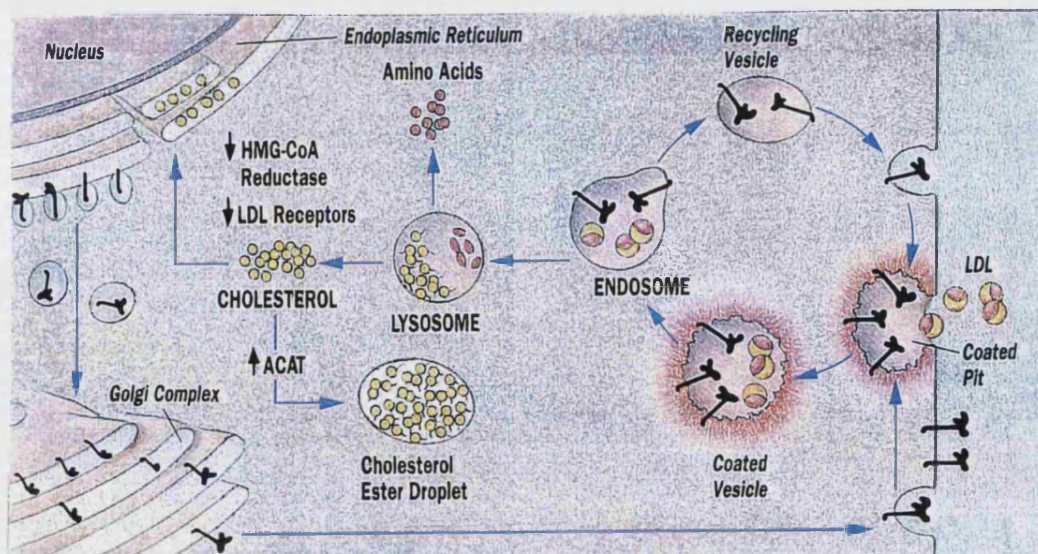

Figure (3). Reproduced by permission from S.M. Grundy, Cholesterol and Atherosclerosis, 1<sup>st</sup> ed., Gower Medical Publishing, New York, 1990 ©.



### **1.5 Formation of an atherosclerotic plaque by LDL**

Atherosclerosis develops slowly and is instigated by damage to the endothelium of arteries. According to the original model proposed by Ross and Glomset<sup>5</sup>, the damaged endothelium becomes “leaky” and is penetrated by LDL particles and blood platelets. In response to the release of hormones such as platelet-derived growth factor, smooth muscle cells in the layer below the endothelium multiply and migrate into the damaged area. At the same time white blood cells, known as monocytes, migrate to the area and are activated to become scavenger cells called macrophages [Figure (4)]. Macrophages are large cells capable of ingesting foreign particles. Normal macrophages possess some LDL receptors, but if LDL is peroxidised (Section 1.6) it is recognized by other receptors known as the acetyl-LDL receptors or the scavenger receptors. LDL bound to these receptors is taken up with enhanced efficiency, so that cholesterol rapidly accumulates within the macrophage and may convert to a foam cell [Figure (5)]. Once formed, the foam cells enter the arterial wall and accumulate together with lipids. This causes necrosis of some foam cells, such that cholesterol esters are released and form a lipid core.

In the coronary arteries the smooth muscle cells and fibrous tissues have a tendency to cover the lipid and foam cell core, giving rise to a fibrous plaque [Figure (6)]. Fibrous plaques encourage the accumulation of blood clots and subsequent hemorrhaging into the plaque causes it to rupture. Following rupture, platelets may aggregate and increase the size of the obstruction. When the plaque grows too large vascular occlusion occurs and this leads to a lack of blood supply to the heart and myocardial infarction. This myocardial infarction maybe fatal leading to cardiac failure, alternatively recovery or part recovery is possible.

Several lines of evidence implicate oxidatively-damaged LDL in atherogenesis. Lipoproteins with many characteristics of oxidative damage have been isolated from atheroma<sup>6</sup>. Several chemically-unrelated antioxidants, which are potent inhibitors of lipoprotein lipid peroxidation *in vitro*, retard atherogenesis in animal models of hypercholesterolemia<sup>7</sup>. *In vitro* work demonstrates that extensively oxidized LDL is rapidly taken up and degraded by cultured macrophages<sup>8,9</sup>, suggesting a role for LDL oxidation in lipid accumulation by the arterial wall. Oxidized LDL is strongly cytotoxic, perhaps explaining why cellular necrosis is prominent in advanced atherosclerotic lesions.

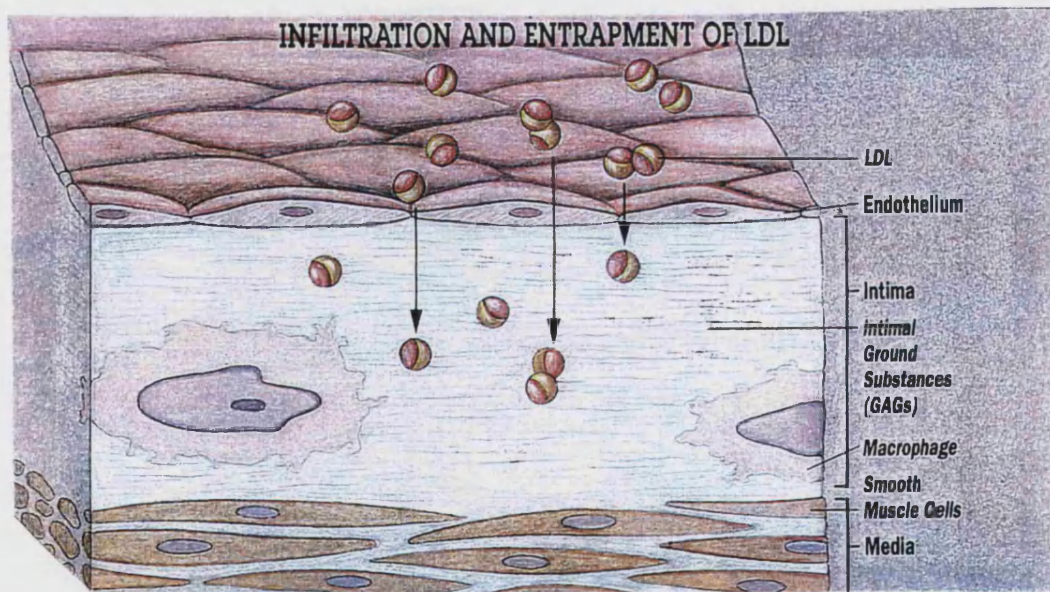

Figure (4). Reproduced by permission from S.M. Grundy, Cholesterol and Atherosclerosis, 1<sup>st</sup> ed., Gower Medical Publishing, New York, 1990 ©.

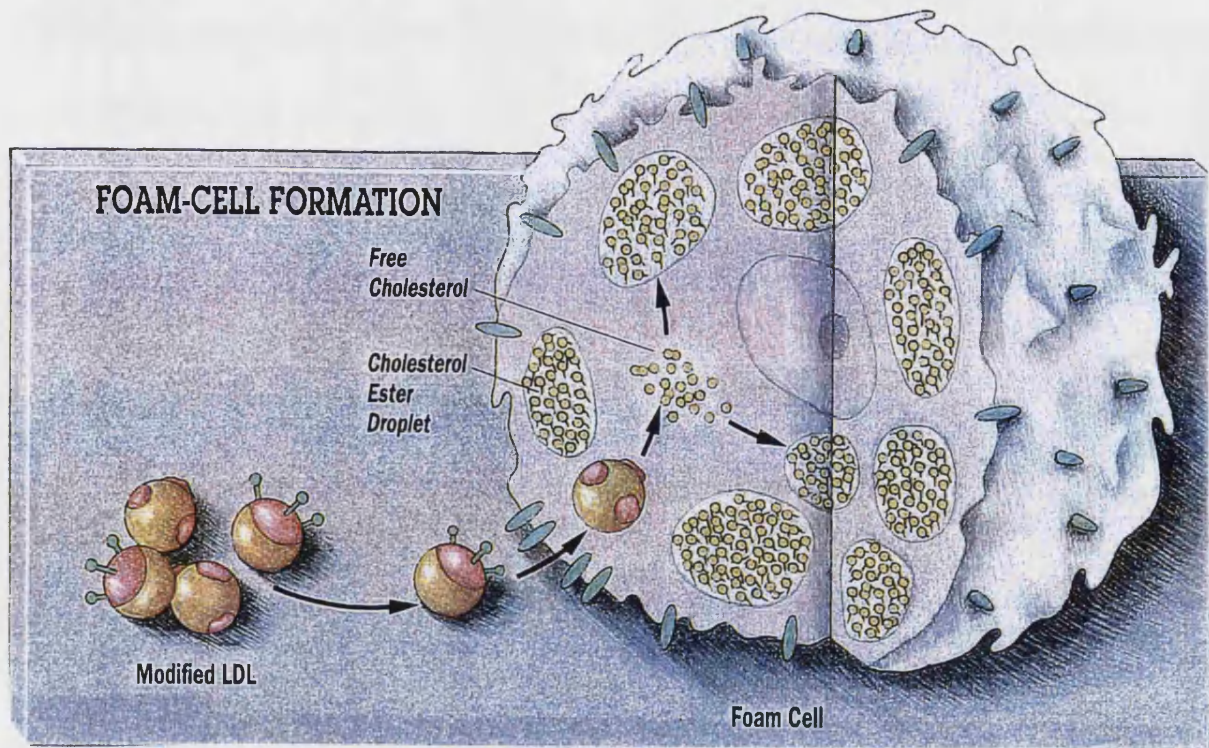

Figure (5). Reproduced by permission from S.M. Grundy, Cholesterol and Atherosclerosis, 1<sup>st</sup> ed., Gower Medical Publishing, New York, 1990 ©.

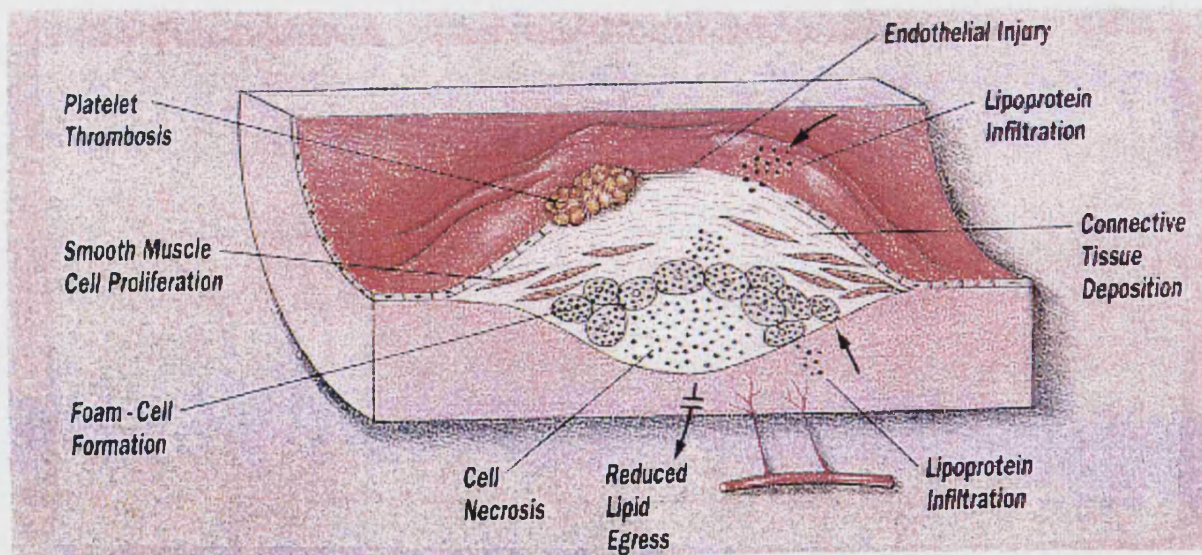

Figure (6). Reproduced by permission from S.M. Grundy, Cholesterol and Atherosclerosis, 1<sup>st</sup> ed., Gower Medical Publishing, New York, 1990 ©.

## **1.6 Lipid peroxidation**

Lipid peroxidation has been broadly defined by A.L.Tappel as the “oxidative deterioration of polyunsaturated lipids”. Lipid peroxidation, such as that which occurs to form modified LDLs, is mainly caused by two species present in the body:

### **(1) The hydroxyl radical, $\text{OH}^\bullet$**

This is formed by the reaction of hydrogen peroxide with iron or copper ions:

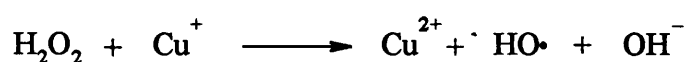
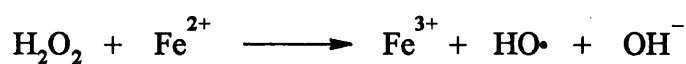

Scheme (1)

Copper is present in the body as part of the proteins albumin and histamine, while iron is an essential component of haem, the oxygen carrying component of red blood cells.

### **(2) The superoxide radical anion, $\text{O}_2^{\bullet-}$**

This species is produced along with hydroxyl radicals as a result of enzyme catalyzed reactions and by the action of phagocytes. Exposure of cells to ionizing radiation, such as X-rays and  $\gamma$ -rays, can also produce the superoxide radical anion.

### (3) Initiation and propagation

The peroxidation process essentially proceeds *via* a free radical mechanism, which consists of initiation and propagation stages. The first chain initiation step in a membrane or polyunsaturated fatty acid is caused by a species that can abstract a hydrogen atom from a methylene group especially when it is adjacent to a double bond (i.e. an allylic system). The hydroxyl radical is able to do this.

e.g.



Scheme (2)

By contrast, a superoxide anion is insufficiently reactive to abstract a proton from lipids, however, once the radical anion is protonated the reaction may proceed.

The presence of double bonds in lipids weakens the adjacent C-H bonds, thus making hydrogen abstraction easier. The resulting allyl radical is then stabilised by resonance to form a conjugated diene. Under aerobic conditions the conjugated diene combines with oxygen forming a peroxy radical or (ROO<sup>•</sup>) [Scheme (3)].

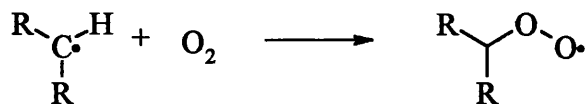

Scheme (3)

Propagation then occurs by the abstraction of a hydrogen atom from another lipid methylene group. The resulting carbon radical can react with oxygen, thus forming another peroxy radical and hence a chain reaction.



Scheme (4)

Other reactions include formation of a cyclic peroxide from the peroxy radical, through attack at a  $\beta$ -double bond. The product may then fragment to form aldehydes and other products [Scheme (5)]:

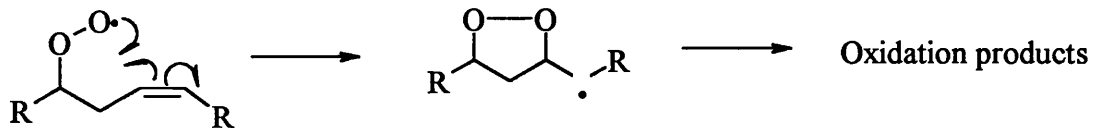

Scheme (5)

A summary of one overall reaction is given below:

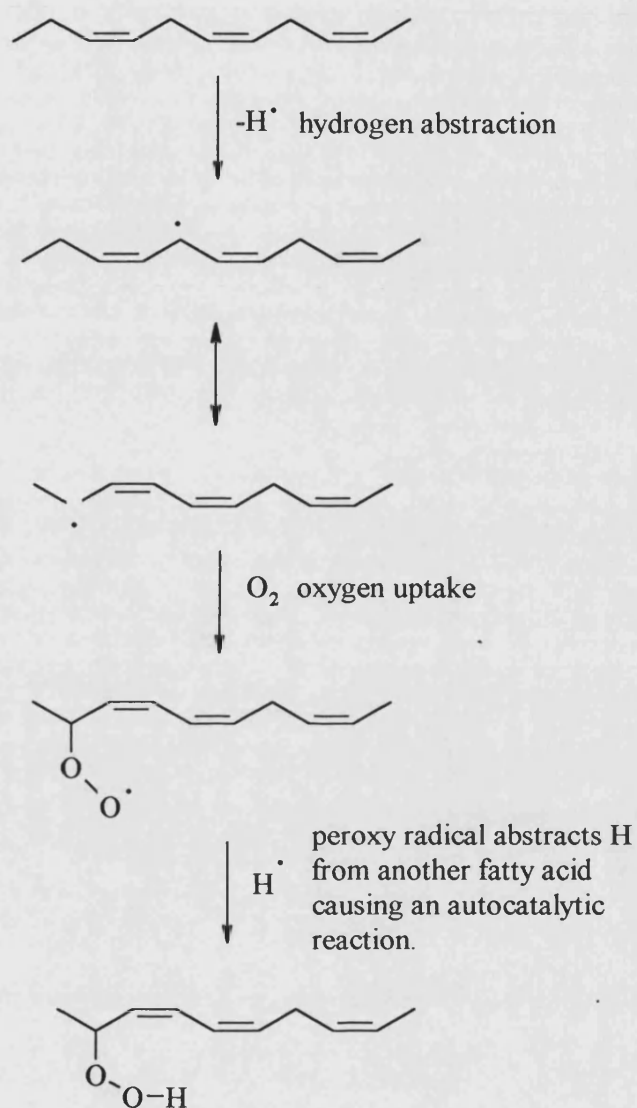

Scheme (6)

If oxidants do indeed initiate atherosclerosis, or contribute to its pathology, then an increased intake of antioxidants (in particular lipid soluble chain-breaking antioxidants that accumulate in lipoproteins) might be expected to have a beneficial effect.

## 1.7 Autoxidation and Antioxidants

Autoxidation is the process by which chemical compounds react with molecular oxygen. With certain functionality this oxidation is particularly facile, leading to the breakdown of the substrate and the generation of peroxides [Section(1.6)].

Autoxidation is responsible for the deterioration of many manufactured plastic and rubber goods. Most susceptible to autoxidation are fats. Fats are present to a large extent in virtually all foods. Indeed, prevention of autoxidation is vital and countless synthetic antioxidants have been developed for this purpose.

A good antioxidant should fulfil several criteria. It must be effective as an electron or hydrogen donor; the resulting radical must be sufficiently stabilized so that the electron density of the unpaired electron is not localized, and thus reactive towards chain transfer. Similarly the radical should be sterically hindered for maximum effect; the original species must be stable towards autoxidation itself; and finally for many radical applications the compound must be sufficiently lipid soluble so that it is concentrated in areas where it is most effective.

Most antioxidants are phenols or aromatic amines and usually act *via* a chain-breaking mechanism [Section (1.8)]. They efficiently donate a hydrogen atom to a peroxy or alkoxy radical forming stable radicals, so interfering with the propagation of lipid peroxidation

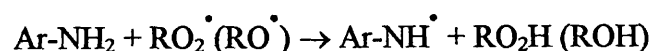
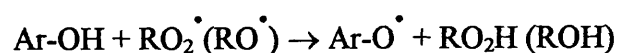

Scheme (6)



The nitrogen or oxygen centered antioxidant radical so produced is insufficiently reactive to abstract hydrogen from the substrate because of delocalisation of the unpaired electron into an aromatic ring moiety. Instead, both species act as chain terminating agents unless a mechanism exists for their reduction back to the antioxidant.

### 1.8 Vitamin E

Perhaps the best known phenolic antioxidant is  $\alpha$ -tocopherol, the major constituent of vitamin E (2). Ubiquitous in nature,  $\alpha$ -tocopherol is one of the most powerful chain-breaking antioxidants<sup>10</sup>.

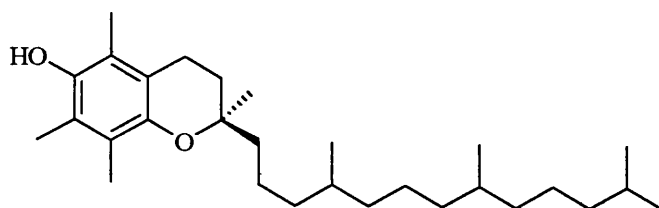

(2)

The lipophilic side chain of  $\alpha$ -tocopherol ensures that the antioxidant will concentrate in the interior of membranes and be transported in lipoproteins, particularly by LDL.  $\alpha$ -Tocopherol protects against lipid peroxidation by quenching and reacting with singlet oxygen and also by reducing the superoxide radical anion. The steps in the oxidation of  $\alpha$ -tocopherol is shown in Scheme (7), and the mechanism by which the  $\alpha$ -tocopheryl radical is regenerated *in vivo* by ascorbic acid, vitamin C, is summarised in Scheme (8).

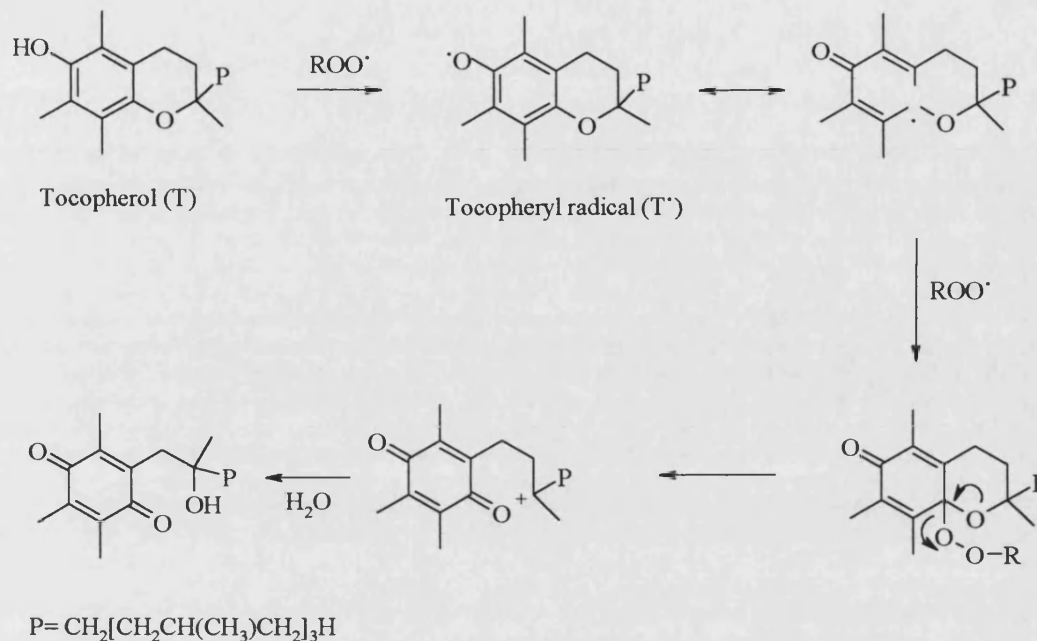

Scheme (7)

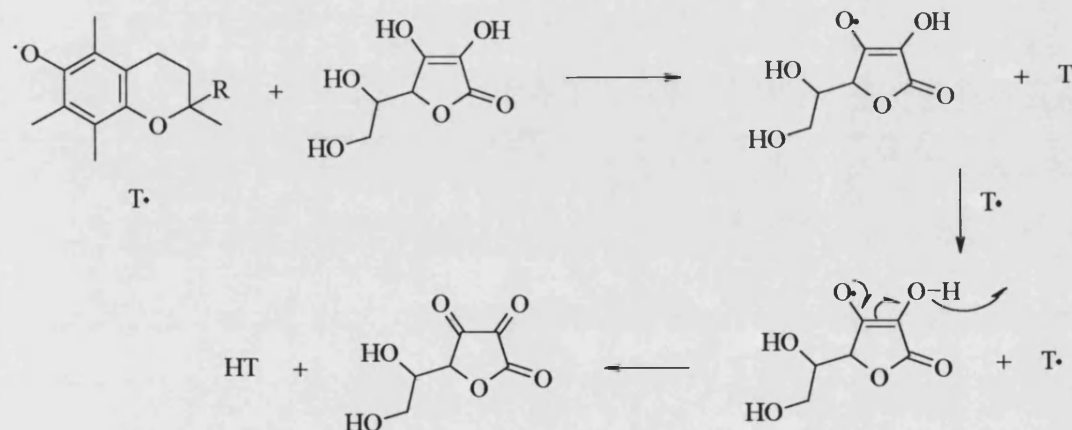

Scheme (8)

A synergism between vitamin E and vitamin C (ascorbic acid) in trapping free radicals was first suggested by Tappel in 1968. Studies by Slater's group confirmed that ascorbic acid can reduce the  $\alpha$ -tocopheryl radical back to  $\alpha$ -tocopherol [Scheme (8)] and this reaction has since been shown to occur in intact membranes. Thus, addition of ascorbate to membranes containing vitamin E can

have antioxidant as well as pro-oxidant effects. Reduction presumably occurs close to the membrane surface, since it is unlikely that the polar vitamin C molecule can enter the hydrophobic interior.

### 1.9 Previous research

Chain-breaking antioxidants, such as vitamin E and its analogues, have been shown to be effective agents in the protection of biological tissue from oxidative stress<sup>1, 11, 12</sup>. Moreover, during the last decade several *in vitro* and *in vivo* studies suggest that modification of LDL by lipid peroxidation increases their atherogenic properties<sup>13</sup>. This hypothesis is further supported by numerous *in vitro* studies showing that antioxidants, including vitamin E, can inhibit LDL oxidation, induced by cells or metal ions<sup>14</sup>.

The potential beneficial therapeutic effects of potent inhibitors of lipid peroxidation encouraged Sainsbury and co-workers to develop novel compounds which when tested *in vitro* should be more potent than vitamin E. Initially our group sought to improve the selectivity exhibited by probucol (3), 2,2-bis(3,5-di-*tert*-butyl-4-hydroxyphenylthio)propane a drug introduced by Marion Merrell Dow as a LDL-cholesterol lowering agent.

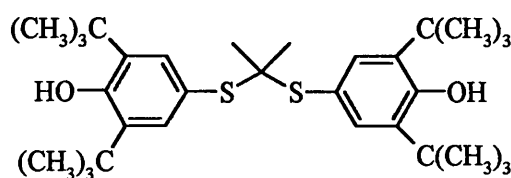

(3)

American and Japanese scientists have found that the anti-atherogenic effect of probucol in rabbits is far greater than expected from its cholesterol-lowering ability. This suggested that its antioxidant activity may work by inhibiting the local oxidative modification of LDL in the arterial wall. Indeed, when administered to human plasma, 45% of this compound was found to bind to LDL and 15% to VLDL<sup>15</sup>. The residual 40% was assumed to be retained by other lipids, including HDL and proteins. Although probucol was indeed effective, the search for a new lead compound continued. For example it was hoped that the next generation of compounds would not bind to HDL, since HDL is considered to be responsible for the transport of cholesterol to the liver, where it is degraded. Interference with this process would not be beneficial<sup>16</sup>.

Before any compounds were synthesized at Bath, it was necessary to recognise what important attributes are likely to be required for such a chain breaking antioxidant.

From numerous studies, it was concluded that the ideal candidate should possess the following features:

- (a) an aromatic “head” bearing substituents to determine an oxidation potential of approximately +0.4V.
- (b) a lipophilic tail capable of “anchoring” the antioxidant in the artery wall so that the head can intercept invasive radical species in the blood stream.
- (c) possible regeneration of the “spent” antioxidant by vitamin C.

The first compounds to be studied by our group<sup>17</sup> were the indenoindoles (4), the quinoxalines (5) and the phenazines (6).

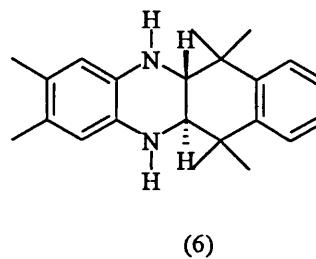
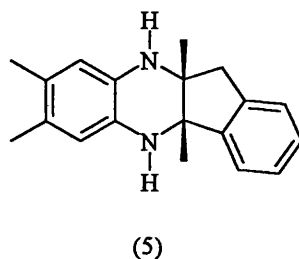
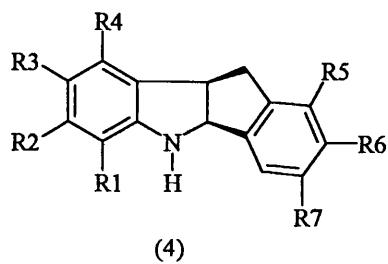

All of these compounds readily form radical cations and, by deprotonation at nitrogen, give radicals delocalised by the aromatic ring bonded to the NH group. Lipophilicity is then provided by the other fused rings. It should be noted that much substitution about the locus of oxidation is needed to prevent the radical being quenched by attack by other endogeneous radical species.

Although all these compounds were found to be very potent antioxidants, unfortunately they failed to show selective binding to LDL. This was considered to be essential if arterial plaque deposition was to be inhibited. There is some evidence to suggest that the lipophilic phytol group of the natural antioxidant vitamin E locates the latter to LDL in this way. The lack of selectivity was a problem and since the lipophilic nature of the steroids is well established, Sainsbury and co-workers<sup>17</sup> synthesized a series of indolines fused to commonly available steroidal units in an attempt to remedy this problem. Such an example is compound (7)

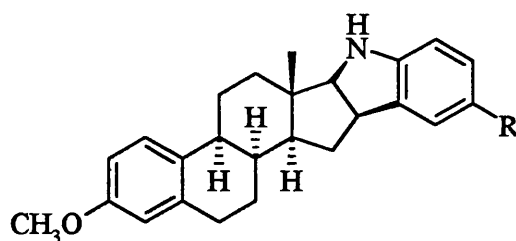

(7)

This and other indolinosteroids certainly bound well to lipoproteins, much better than, say, the indenoindoles, but there was little differentiation between the various forms. Thus a significant incorporation into HDL was observed. It will be recalled that HDL is considered beneficial, so that inhibition of its normal function was undesirable. These results necessitated a re-evaluation of indolines with lipophilicity rankings intermediate between that of the steroidal derivatives and the simple indenoindoles.

Eventually the problem of selective incorporation was solved, by the synthesis of the indolenines (8-10) ( $R=iPr$  and  $R=tBu$ ). These compounds react with alkylolithiums, thereby affording  $\alpha$ -substituted indolines. By selecting alkylolithiums of varying lipophilicity a series of products with a range of LDL affinities were formed and tested. The best compounds<sup>17</sup> obtained in this series were the 6-(*N,N*-dibenzylamino)hexyl derivative (8) ( $R=iPr$ ) and the ethers (9) ( $R=tBu$ ) and (10) ( $R=tBu$ ).

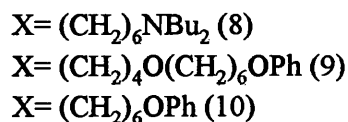
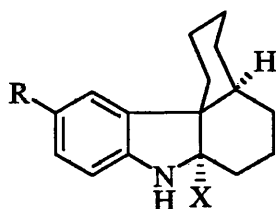

These indolines were found to show better selectivity and percentage binding values than probucol. For example, the first compound (8) has a very high LDL incorporation value of 75%, while 10% is retained in VLDL. For the ethers (9) ( $R=tBu$ ) and (10) ( $R=tBu$ ) the values are 60 and 10% and 55 and 15%, respectively.

A related compound<sup>18</sup> (11) showed 30% binding to LDL and 20% binding to HDL.

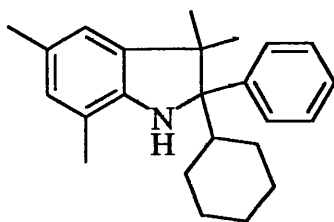

(11)

For various reasons this compound, although not the best, was selected by Astra Pharmaceuticals for pre-clinical evaluation. Watanbe rabbits, which have a severe disposition to atherosclerosis, were fed a diet containing the antioxidant (11) over several weeks. They were then sacrificed and examined, but insufficient reduction of arterial plaque development was noted to warrant further testing. It must be said, however, that this disappointing result was none too reliable as the Watanbe rabbit is a very poor mimic of the human condition. There are other animal modes, but in the case of small mammals it is hard to determine the progression of plaque growth in tiny arteries. Larger animals are expensive to maintain besides raising many other difficulties, not least ethical ones. For this reason rabbits are still the animals of choice, but as just indicated the results are notoriously hard to interpret. In the Swedish trial the degree of plaque inhibition was less than that shown by probucol and this was enough to discourage further interest in the project-at least by Astra!. One overwhelming feature of most of the compounds submitted for assessment is the presence of at least one chiral centre. Only in the case of one indenoindole, synthesised very early on by a previous worker was resolution

carried out. Detailed biological testing of the enantiomers of this compound have not been reported.



## 2.0 The Carbazoles

1,2,3,4,4a,5,6,7-Octahydro-11-isopropyl-1*H*-benzo[*d*]carbazole (12) can be regarded as the starting point for a series of antioxidants. Such a compound embodies the same type of oxidisable indole/indolinene 'head' as the related dihydro and tetrahydroindenoindoles described earlier and its structure is fully substituted at C-3 of the indole unit. This feature would ensure that substitution at this position does not occur in the radical cation, or radical, formed after oxidation. Secondly, the imine group can be used as a means of substituting a range of groups with varying lipophilicity so that the overall affinity of the antioxidant so formed to LDL can be finely tuned.

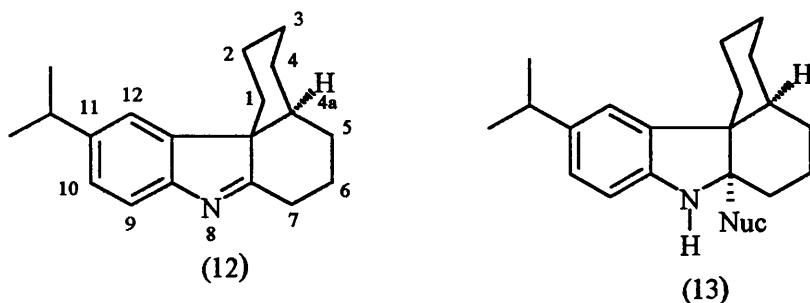

Indeed, antioxidants (13) have already been synthesised at Bath from the addition of various alkyllithiums to the imine bond of the indolenine (12). Apart from the very low yields in these reactions, another problem with the products as antioxidants is that the C-9 position is unsubstituted. This allows the possibility that the ensuing radical cation, or radical, could be quenched by attack at this site by a nucleophile or a radical, respectively. Since the whole point of forming a

chain-breaking antioxidant hinges upon the stability of its oxidised form this is a very serious matter and one that must be addressed.

One approach would be to use a 2,4-disubstituted phenylhydrazine in the Fischer indolisation reaction, thus to form a 9-substituted indolenine. In fact, two syntheses of this type have already been attempted by Dr A. Ninan in this Department, but even in the hands of such an experienced chemist the yields were very poor.

It became one of the author's objectives to see if it was possible to improve matters by substituting the mono-substituted indolenine (12) directly at C-9. In addition, we decided to investigate the possibility of using imine-enamine tautomerism to functionalise C-7 and make this alternative anchor point for lipophilic units [Scheme (9)].

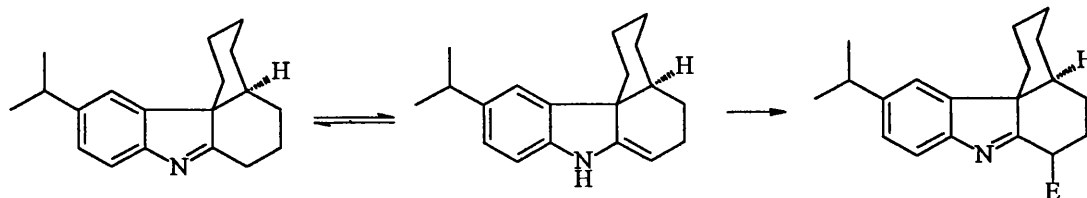

Scheme (9)

In order to advance both of these objectives it was necessary to synthesise a stock of (12) using the Fischer indolisation of *trans*-1-decalone. Unfortunately, this ketone has two  $\alpha$ -hydrogens. Both can become involved in the ring-closing reaction of the intermediate hydrazone formed with 4-isopropylphenylhydrazine [Scheme (10)].

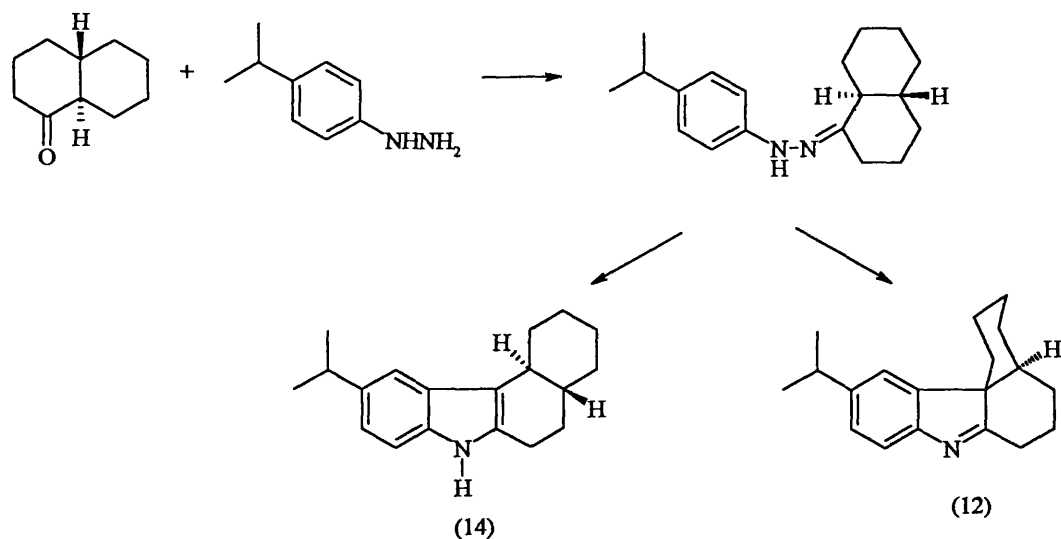

Scheme (10)

This is a well known problem with unsymmetrical ketones. In 1978 Miller and Schinske<sup>19</sup> noted that phenylhydrazones of 2-substituted cyclohexanones gave both indoles and indolenines when reacted with dilute sulfuric acid. Early investigations<sup>20-23</sup> suggest that the course of the reaction is dependent on the stereochemistry of the substrate. However, this theory has not been sustained by more recent research, where the ratio of products seems to be dependent upon the nature of the acid used as catalyst<sup>24</sup>. In general, the conclusion is that weak acids, or low acid concentrations, promote cyclisation in favour of (12) whereas stronger or higher acid concentrations promote cyclisation in favour of a tetrahydrocarbazole (14)

The essential feature in the Fischer Indole synthesis is the direction of tautomerism as illustrated [Scheme (11)]. The difference in the yields of the above products then depend upon those factors, which favour one tautomer over the other. Normally protonation of the individual tautomers is deemed to be essential for

rapid cyclisation (paths B and C), but cyclisation without protonation (paths A and D) is also known to occur<sup>25</sup>.

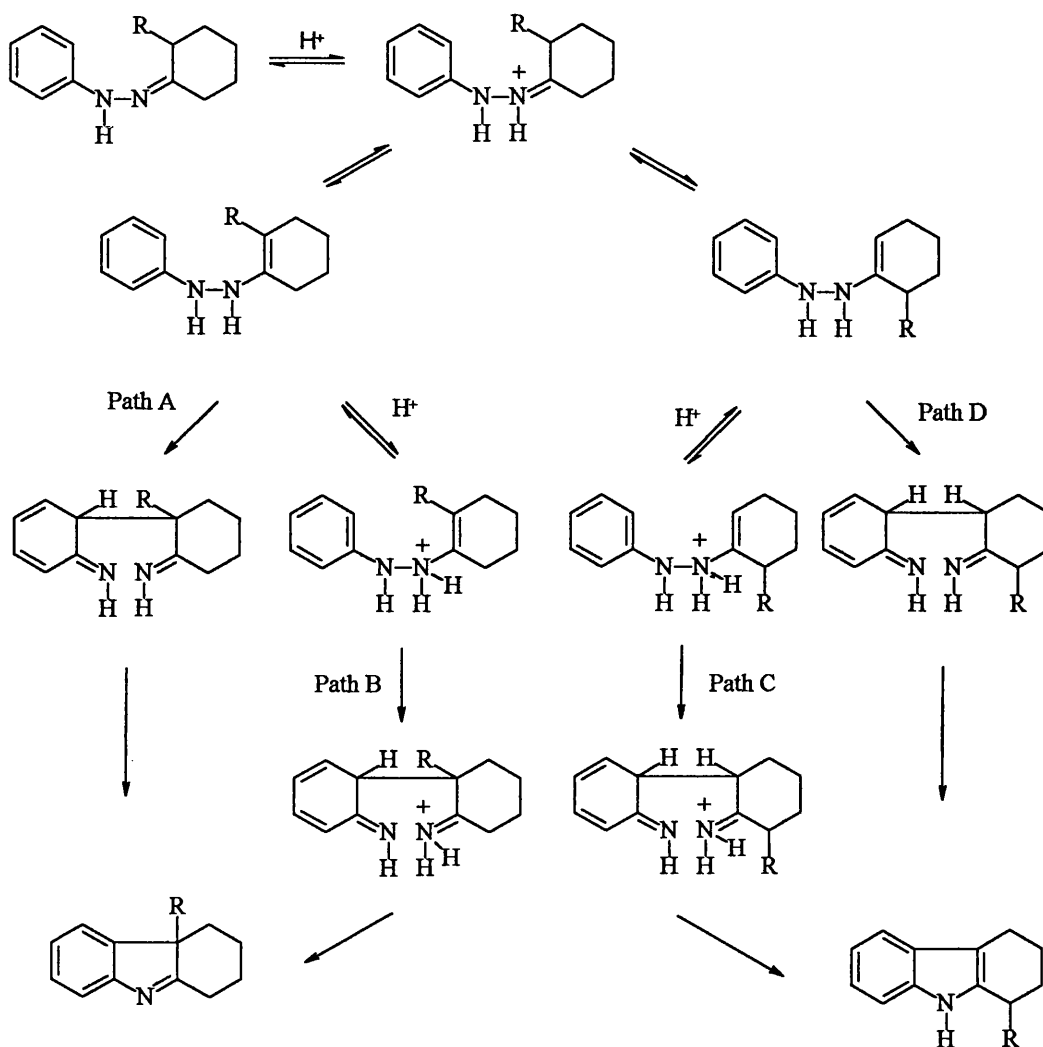

Scheme (11)

Sainsbury and co-workers have also noted that the nature of the acid and the addition of sodium acetate dictate which of the indole (14) or the indolenine (12) are favoured in the indolisation of 1-decalone with 4-isopropylphenylhydrazine.

From MM2 calculations, it appears that the indole (14) is favoured over the indolenine (12) (but only by about 10 kcal.mol<sup>-1</sup>). These data were obtained with the PC Spartan programme.

Sainsbury *et al.* found that using 4-sulfosalicylic acid in glacial acetic acid at 110°C favours the formation of the indole (14) over the indolenine (12) (5:1). However, when toluene 4-sulfonic acid was used in toluene at 100°C a ratio of 1:1 (indole:indolenine) was observed. The addition of sodium acetate to the reaction mixture was found to enhance the formation of the corresponding indolenine (12) rather than the expected indole (14). In particular, when 10% sodium acetate in acetic acid was used, compound (12) outweighed (14) by a ratio of 5:1. This bias was increased slightly when 4-isopropylphenylhydrazine hydrochloride was used instead of 4-isopropylphenylhydrazine.

The effect of sodium acetate is assumed by us to extend beyond that of simply acting as a buffer and acts to modify in some way, the energy content of at least one intermediate in the reaction process. In the absence of acetate ion, (14) dominates as a result of the natural preference of the less sterically constrained (*E*)-hydrazone (15), thus leading directly to the less substituted ene-hydrazine (16) by prototropic rearrangement. However, in the presence of sodium acetate the indolenine (12) is preferred as now the acetate may combine with either the (*E*) or (*Z*) hydrazone to form a common tetrahedral intermediate (17). This could lose acetate ion returning either hydrazone, but eliminates acetic acid to favour the more substituted ene-hydrazine (18), resulting in indolenine formation, [Scheme (12)].

In essence the presence of the acetate ion seems to facilitate the higher energy pathway.

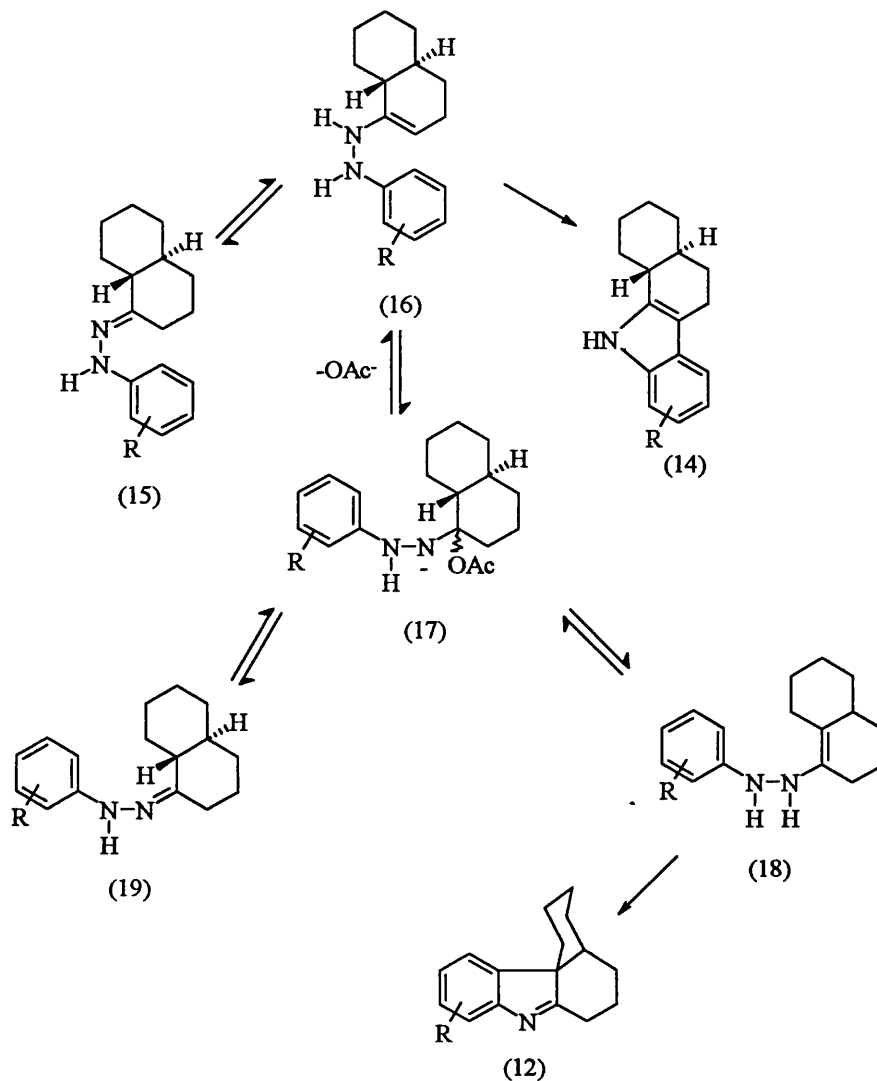

Scheme (12)

In the authors hands the earlier work at Bath was repeated successfully and a good supply of the indolenine was built up, despite the need to separate it from the isomeric indole by column chromatography.

We were now in a position to consider some new work. It is well known that indoles and other nitrogen heterocycles upon *N*-acylation or *N*-sulfonation can be deprotonated by the action of alkyllithiums at sites proximate to the *N*-activating group<sup>26-31</sup>. Once deprotonated the anion is stabilised in the form of a chelated complex [Scheme (13)].

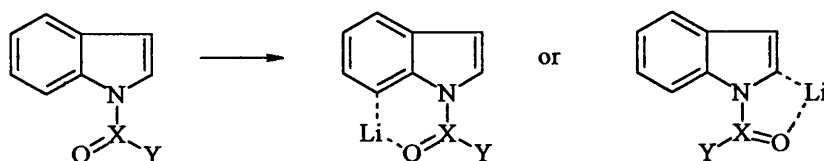

Scheme (13)

Normally, the 2-position of indoles is the site of complexation and subsequent attack by added electrophiles occurs at this position. However, should our indolenine (12) be activated in this way we speculate that either C-7 or C-9 might be involved.

In an initial attempt to investigate these possibilities we reacted (12) with di-*tert*-butoxycarbonate and sodium acetate in THF at reflux. The reaction was extremely slow.

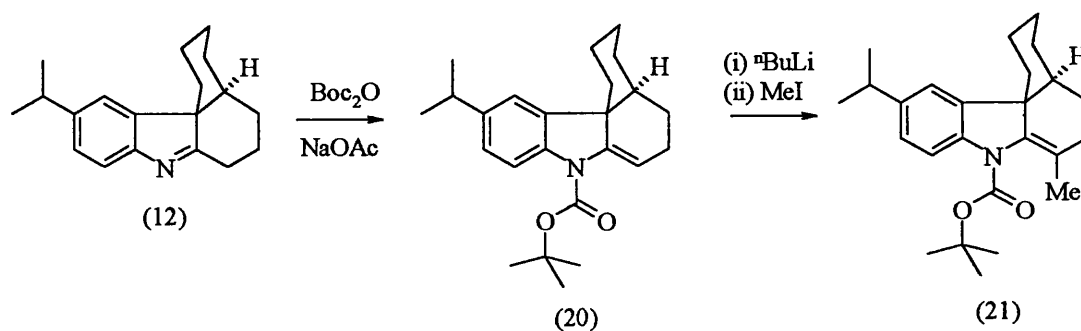

Scheme (14)

After 4-5 weeks we noted the formation of the desired *N-tert*-butoxy derivative (20), but only in 36 % yield. The  $^1\text{H}$  NMR spectrum of the product exhibits a double doublet at  $\delta 5.9\text{ppm}$ , which corresponds to the resonance of the olefinic proton at position C-7. The extremely slow reaction rate must surely reflect the steric congestion around the indolenine nitrogen atom and/or the reluctance of the system to tautomerise.

Next the *N-tert*-butoxy derivative (20) was redissolved in ultra dry THF and the solution cooled to  $-78^\circ\text{C}$ . *tert*-Butyllithium was added slowly and, after stirring for 90 min, a deep red coloration was observed. At first this was taken to mean the formation of the chelated carbanion, however, when the solution was quenched with methyl iodide the now colourless reaction mixture did not contain any new products. In similar reactions now using either allyl chloride or deuterium oxide as electrophiles no new products were either detected or isolated. Bearing in mind the constraining nature of the cyclohexane ring fusion in the indolenine and the comparative difficulty in obtaining this compound we now switched to the simpler model 1,2,3,4-tetrahydro-8-isopropyl-9b-methylcarbazole (22). This was synthesised from a Fischer indolisation reaction between 2-methylcyclohexanone and 4-isopropylphenylhydrazine in essentially the same manner as needed for the indolenine (12), except this compound appeared to be the sole reaction product.

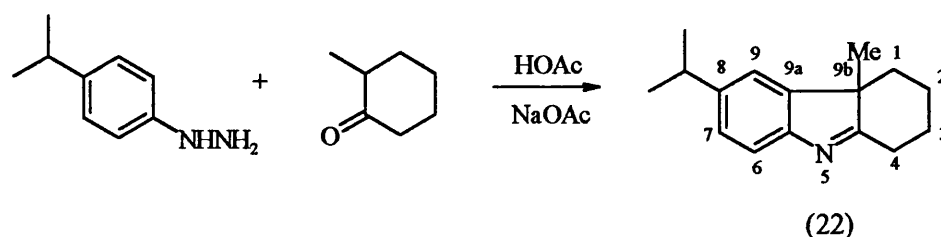

Scheme (15)



Reacting (22) with di-*tert*-butoxycarbonate and sodium acetate in THF afforded the desired *N*-acylamine (23) as the sole product in less than 3 days; considerably faster than with the previous compound.

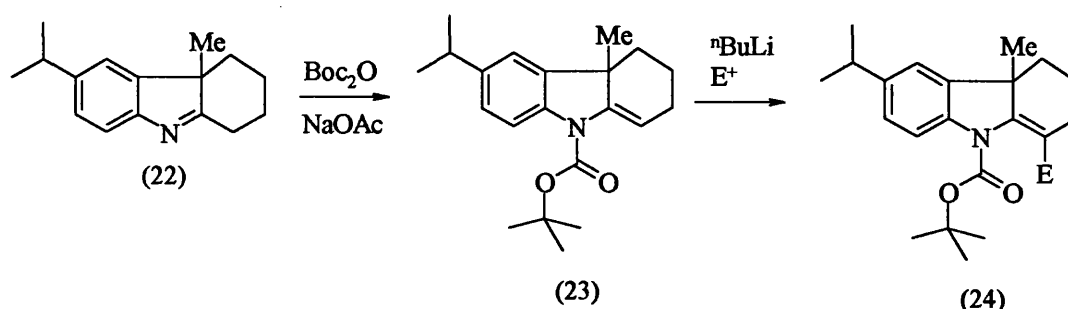

Scheme (16)

This boded well for the lithiation/substitution reaction. However, a lithiation attempt with *tert*-butyllithium and subsequent addition of methyl iodide gave only starting material. Furthermore, an experiment in which deuterium oxide replaced methyl iodide as the electrophile also returned the *N*-acylated tetrahydrocarbazole (23). We can only assume that activation of carbazole analogues of the type cannot take place through six membered chelation, unlike indoles where this process involves a five membered cyclic array.

With this in mind we now reduced the tetrahydrocarbazole (22) with sodium borohydride to give hexahydroanalogue (25). Here, there is a proton alpha to the indoline nitrogen atom. Once activated and lithiated this could fulfil the requirement for a 5 membered lithium chelate. Katritzky and co-workers<sup>32</sup> have used carbon dioxide as an activating agent in chemistry of this kind. For us it also has the major advantage of being substantially smaller than the Boc group. Hence,

the author decided to repeat the reaction shown in [Scheme (17)] using the method employed by Katritzky *et al.*<sup>32</sup>.

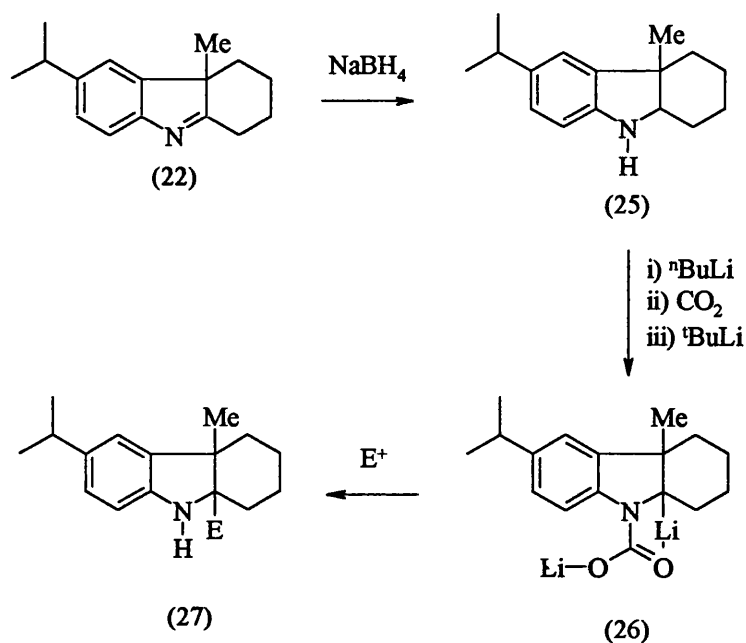

Scheme (17)

First the hexahydrocarbazole (25) was treated with butyllithium, followed by carbon dioxide to form the carbamate (26). A lithiation step was next required using *tert*-butyllithium and finally the addition of an electrophile to form the  $\alpha$ -substituted hexahydrocarbazole (27).

In practice this reaction sequence seemed to work as planned, but after work up only the hexahydrocarbazole (25) was obtained in near quantitative recovery.

We were unsure of the reason for this failure and decided to move rapidly to another approach, namely halogen-lithium exchange<sup>33, 34</sup>. In order to achieve this, we reacted the *N*-acylated tetrahydrocarbazole (25) with *N*-bromosuccinimide

(NBS) in the presence of a catalytic amount of hydrogen peroxide anticipating that bromination should occur at the enamine  $\beta$ -carbon atom as shown [Scheme (18)].

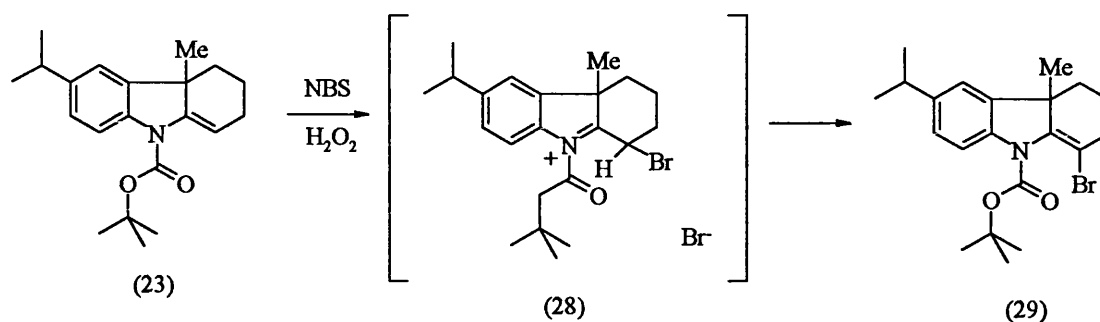

Scheme (18)

In reality however, a multi-component mixture of products was obtained. Separation of the mixture by column chromatography afforded one compound in an almost pure state. The identity of this adduct (30) was initially indicated by FAB spectrometry that revealed molecular ion peaks at  $m/z$  425 ( $M^+$ )/427( $M^+$ +1) *ie.* a true molecular ion at 424/426 in a ratio of 1:1 typical of the isotopic abundance of a compound containing a single bromine atom. A major fragmentation peak occurred at  $m/z$  406/408 indicating the loss of 17 mass units. This together with the IR spectrum, which exhibited a broad band at  $\nu_{\max}$  3160 $\text{cm}^{-1}$  suggested that we had formed the carbinolamine (30) from the iminium intermediate (28) (or its equivalent) [Scheme (18)].

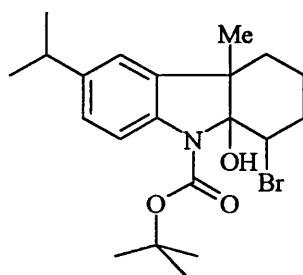

(30)

Interestingly, the  $^1\text{H}$  NMR spectrum of this compound shows the resonance of H-7 as a dd (*ortho* and *meta* coupled) at  $\delta 7.1$  ppm and that of H-9 as a doublet (*meta* coupled)  $\delta 7.2$  ppm. However, the resonance of H-6 at  $\delta 7.4$  ppm is a broad singlet. We considered that this lack of definition was due to the slow rotation of the amide bond, and when the contents of the NMR tube were warmed to  $50^\circ\text{C}$ , the H-6 signal sharpened and now became an *ortho* spin-related doublet. At this temperature a broad signal previously unnoticed was also apparent at  $\delta 6.9$  ppm. This resonance may be due to the carbinolamine hydroxy proton, which was unaccounted for at ambient temperatures. However, a deuterium exchange experiment at ambient temperature was not entirely unambiguous, simply because the original signal was very broad. In addition, there are other resonances in the same vicinity, which render integral changes, before and after, deuteration difficult to measure.

The rest of the  $^1\text{H}$  NMR spectrum remained unaffected by heating and shows H-4 to resonate as an apparent triplet at  $\delta 4.2$  ppm. The coupling constants to  $3\text{H}_\alpha$  and  $3\text{H}_\beta$  are the same ( $J = 4.8\text{Hz}$ ).

Had this compound been formed in higher yield we might have continued work with it, but since it was not we progressed by attempting to functionalise the parent carbazole at C-9.

A report by Iwao *et al.*<sup>35</sup> that indicates that 7-substituted indolines can be successfully prepared via directed lithiation of 1-*tert*-butoxycarbonylindolines in the presence of *sec*-butyllithium and TMEDA [Scheme (19)].

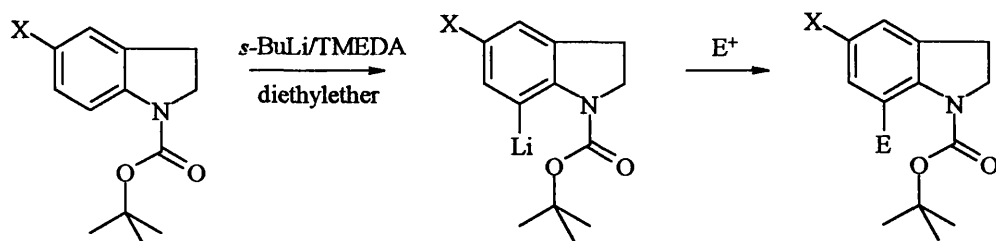

Scheme (19)

This report stimulated us to attempt this methodology with our substrate; the hoped for result is shown [Scheme (20)].

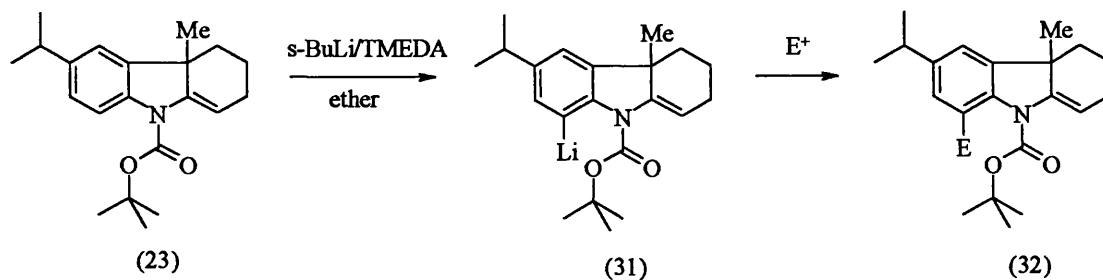

Scheme (20)

However, treatment of the *N*-acylated tetrahydrocarbazole (23) with *sec*-butyllithium in the presence of TMEDA in THF at -78°C for 1 h, followed by quenching with methyl iodide proved totally unrewarding and no substituted product was detected.

There is clearly an unresolved problem in these deprotonation attempts; but with little evidence to provide the basis of new experiments, we decided to attempt a direct bromination of the tetrahydrocarbazole (23), reacting it with NBS in the presence of catalytic hydrogen peroxide, [Scheme (21)].

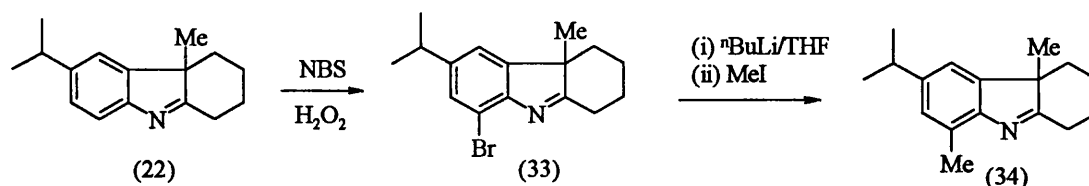

Scheme (21)

After 16 h, TLC analysis of the reaction mixture revealed a new compound which was isolated in a 29% yield. This proved to be the monobromo compound (33), where attack upon the aromatic ring had occurred as indicated by the  $^1\text{H}$  NMR spectrum. In this spectrum two  $^1\text{H}$  doublets were observed; one at  $\delta 7.1\text{ppm}$  and the other at  $\delta 7.3\text{ppm}$ . These doublets are spin-related with  $J=1.5\text{Hz}$ , characteristic of the signals of two meta protons on a benzene unit. This contrasts with the clearly defined AMX pattern of the parent compound (22) at  $\delta 7.2\text{ppm}$  (d  $J_{\text{meta}}=1.8\text{Hz}$ ),  $\delta 7.2$  (dd  $J_{\text{ortho}}=7.9\text{Hz}$   $J_{\text{meta}}=1.8\text{Hz}$ ) and  $\delta 7.5$  (d  $J_{\text{ortho}}=7.9\text{Hz}$ ). Clearly this compound is the C-6 bromo derivative (33).

An attempt to try and increase the yield of (33) by replacing NBS with bromine in the presence of aluminium tribromide was unsuccessful. TLC analysis of the reaction mixture showed the presence of many compounds, but column chromatography was unrewarding. However, mass spectrometry of one component, still crude, showed the presence of molecular ion peaks  $m/z$  at (461), (463), (465) and (467) in the ratio of 1:3:3:1, typical of the isotopic abundance of 3 bromine atoms.

Notwithstanding the low yield of the bromo compound (33) using NBS, we continued to use it in a direct halogen-metal exchange reaction. Treatment with butyllithium in THF and TMEDA at  $-78^{\circ}\text{C}$  under nitrogen, followed by a period at  $-20^{\circ}\text{C}$  and then recooling to  $-78^{\circ}\text{C}$ , gave a deep yellow solution. Methyl iodide was added and the solution was then allowed to warm to room temperature. Upon work up, however, the debrominated tetrahydrocarbazole (22) was obtained. There was no sign of other products, although clearly the intermediate lithiated compound must have formed. The procedure was repeated several times, since we were concerned that water had been inadvertently introduced before the methyl iodide. In each case the result was the same hydrodebromination product. Our conclusion was that methyl iodide is just insufficiently reactive towards the lithiated intermediate, hard though this is to explain.

Turning to the literature, we noted that Keck<sup>36, 37</sup> had successfully allylated halogenated cyclohexanes using allyl stannanes. The general process is summarised [Scheme (22)].

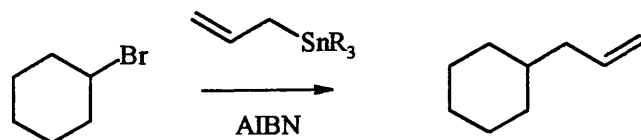

Scheme (22)

With this in mind we decided to adopt the method used by Keck with our brominated substrate. Addition of 0.15eq of AIBN, as radical initiator, to the reaction mixture every hour over a period of 5 days resulted however, only in the isolation of unreacted starting material. The failure of this reaction was not immediately forthcoming, although it may be a result of decomposition of radical species before reaction with allyltri-n-butyltin can take place.

The palladium-catalyzed coupling of haloarenes with alkenes was first introduced by Heck in 1968<sup>38-40</sup> and has subsequently found use in a large variety of syntheses. The overall reaction is shown [Scheme (23)]



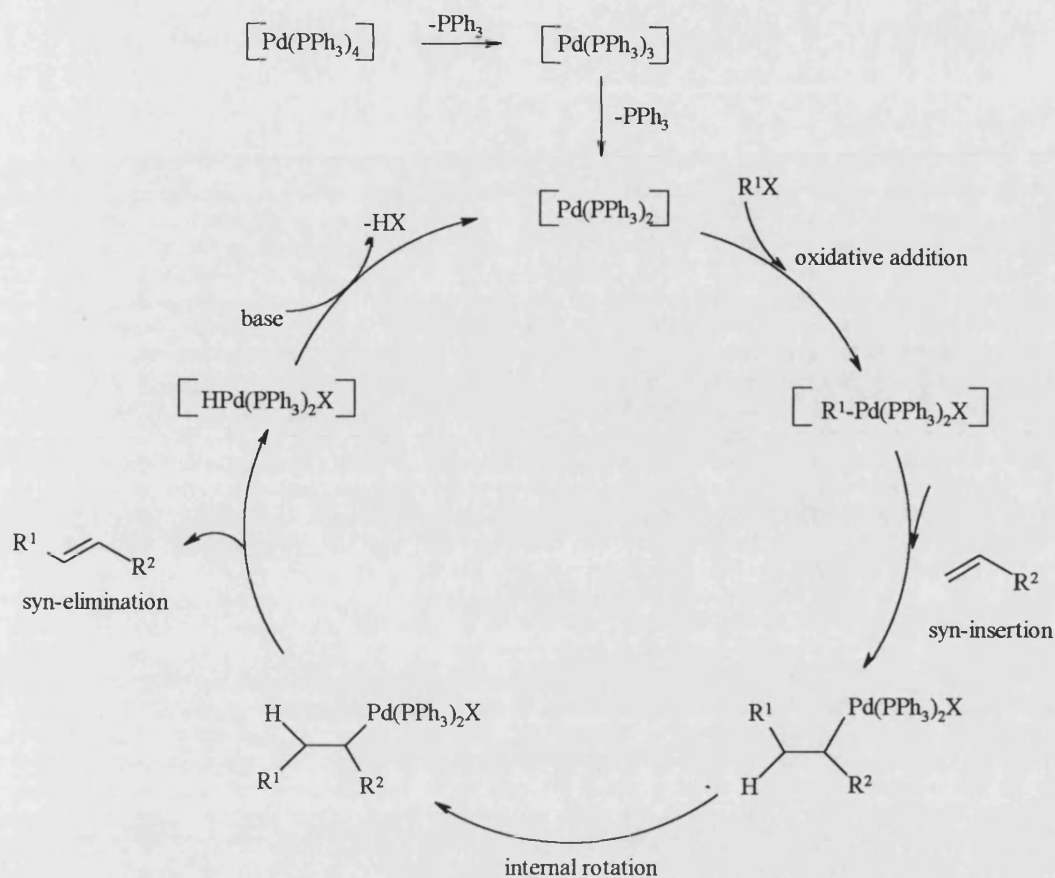

Scheme (23)

Where the mechanism is as follows:

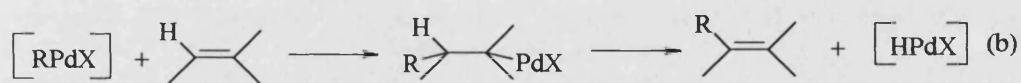
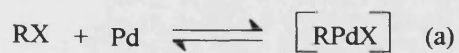

The key step (b) is the palladation of the alkene component by a complex  $[R^1Pd(PPh_3)_2X]$  formed initially from the aryl halide  $R^1X$  and  $Pd^0$ . It should be noted that this process is catalytic in terms of the palladated reagent. A range of halogen (and other groups X) have been used. A weak base such as triethylamine is normally present ostensibly to remove the HX generated.

Reaction of the bromo compound (33) with methyl acrylate in the presence of palladium acetate, triphenylphosphine and triethylamine [Scheme (24)] afforded successfully the alkenylated tetrahydrocarbazole (35) in 41 % yield.

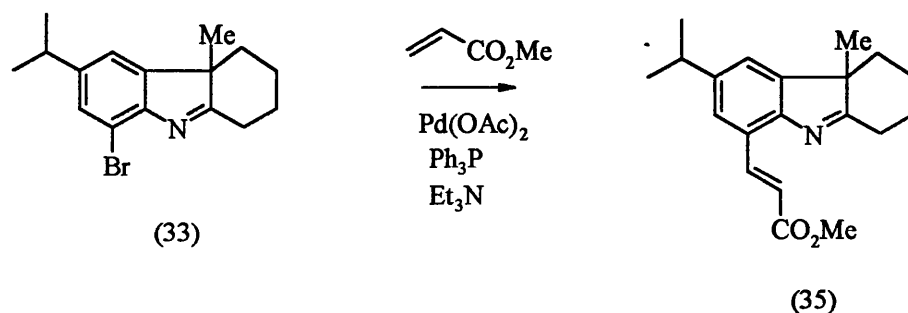

Scheme (24)

In many ways we were surprised that the reaction had worked. For example, the palladation of the bromocarbazole does generate a large structural array, which from our earlier results might have seemed unlikely to react. However, the synthesis of compound (35) prompted us to use the same methodology to prepare a similar derivative from the brominated indolenine compound (36) as shown [Scheme (25)].

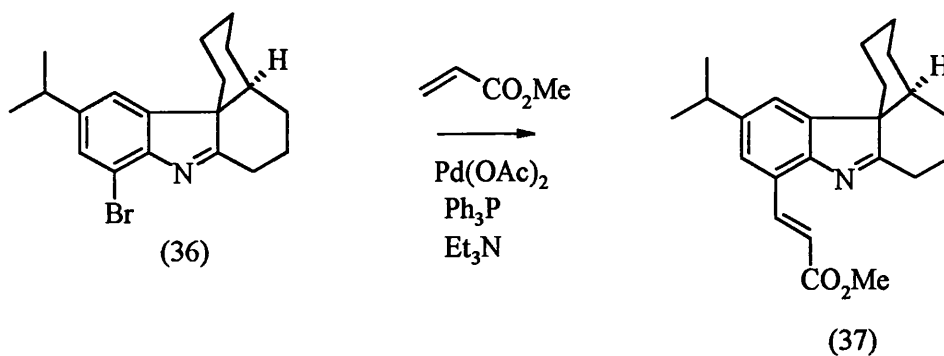

Scheme (25)

Of course the bromo compound had to be synthesised first and when the indolenine (12) was treated with NBS in the presence of a catalytic amount of hydrogen peroxide, at least two new compounds were generated. Unfortunately, these compounds possessed similar retention indices on silica gel, but we were able, nevertheless, to isolate from the mixture the more polar component in the pure state, albeit in low yield 15 %. The identity of the isolated compound was deciphered from examination of spectroscopic data and shown to be the desired compound (36).

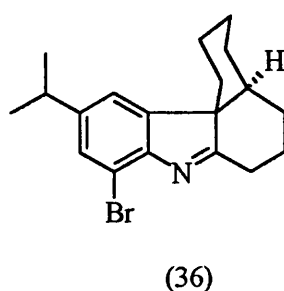

In the <sup>1</sup>H-NMR spectrum of this compound two doublets at δ7.4 and 7.5 with a coupling constant  $J=1.5\text{Hz}$  were observed. The chemical shifts and coupling constants are indicative of a *meta* relationship of protons on the benzene ring. Mass spectrometry reveals molecular ions at  $m/z$  345 and 347, in the ratio of 1:1, consistent with the isotopic abundance for a single bromine atom.

The  $^1\text{H-NMR}$  spectrum of the less polar component of the mixture possesses several idiosyncrasies, the most likely suggestion is that it is a mixture of two dibrominated isomers (38) and (39). Mass spectrometry reveals molecular ions at 425, 427 and 429 in the ratio of 1:2:1, consistent with two bromine atoms. While one bromine atom seems located at C-9 in both components  $^1\text{H-NMR}$  evidence suggests that in one C-7 is the site of the other. For example there are two resonances at  $\delta 5.4$  and  $4.4$  ppm that can be assigned to the alkenic and allylic proton resonances of compound (39). The signals of the other component are not assignable with any degree of confidence, but from a mechanistic point of view a reasonable conclusion is that this compound has to be the 7,9 dibromo isomer (38)

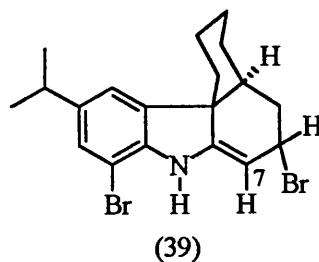
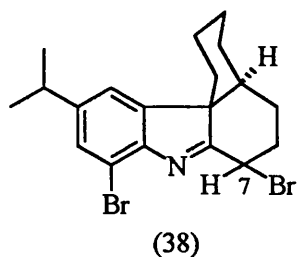

Compound (38) is formed presumably by a reaction involving the enamine (36a), whereas (39) must be the result of a radically induced allylic bromination of the same substrate [Scheme (26)].

The initiation steps involve the generation of a low concentration of bromine from NBS in the presence of the initiator hydrogen peroxide.

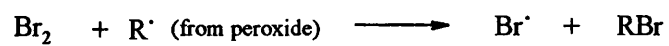
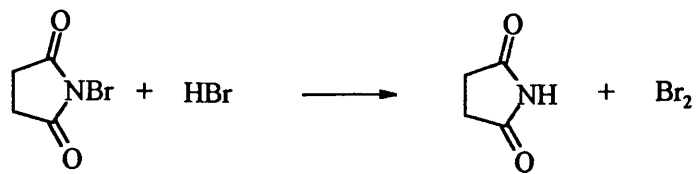

Scheme (26)

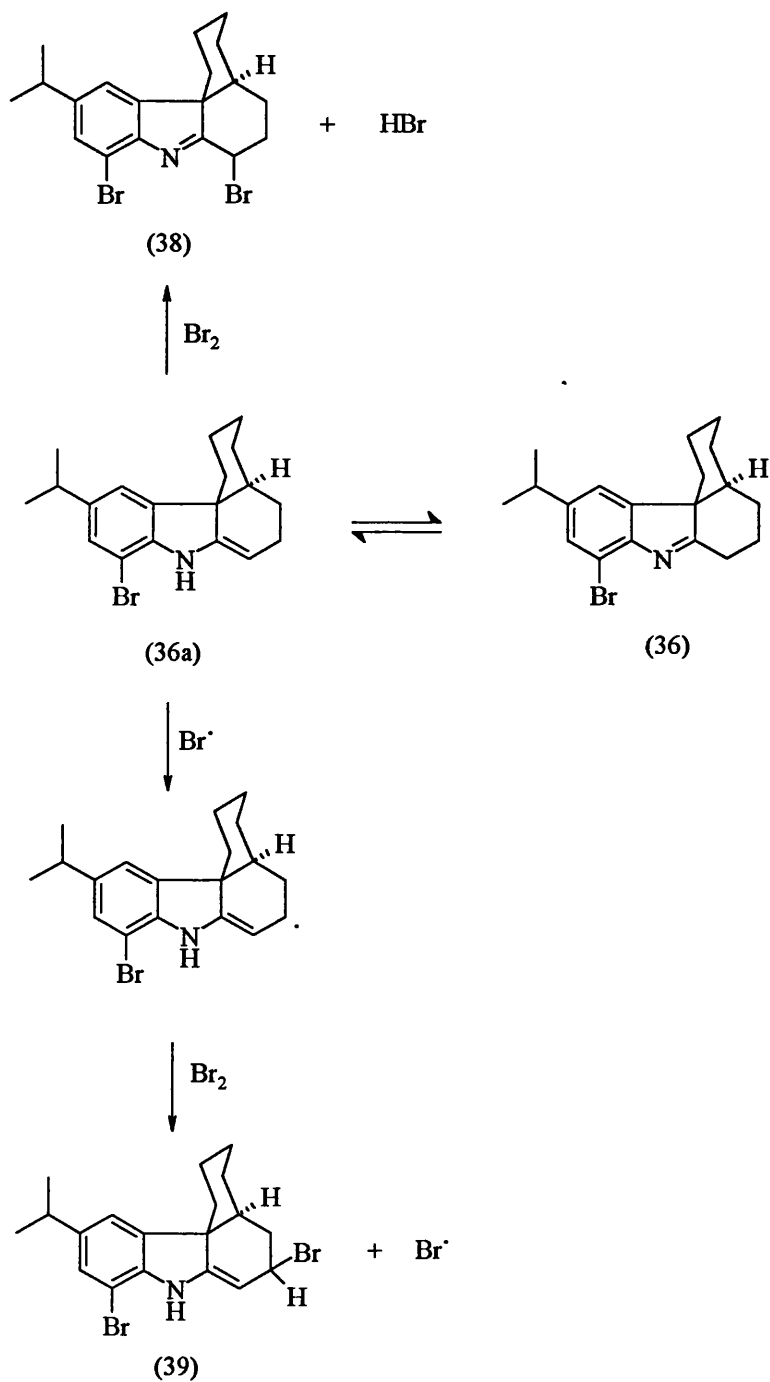

Coupling of the monobrominated compound with methyl acrylate under the same conditions as for tetrahydrobromocarbazole (33) afforded the desired allyl derivative (37) in 41 % yield.

Having obtained the ester (37) the next step was to hydrolyse the ester so to release the acid (40) [Scheme (28)].

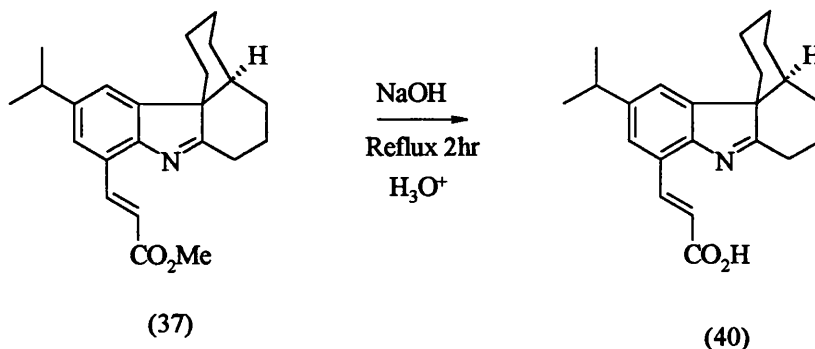

Scheme (28)

It was our intention that either the ester or the acid might be used to anchor various lipophilic units, but although the synthesis of the acid was accomplished by the action of aqueous sodium hydroxide at reflux, further work would have necessitated the preparation of more starting material. At this point we felt other areas might be more rewarding. For example, while the above work was in progress we anticipated using a Claisen rearrangement of the *N*-allyltetrahydrocarbazole (42) to afford the 6-allyl isomer (43) [Scheme (29)]. Once isolated, ozonolysis of this product would give the aldehyde (44). This, or a derivative, could then serve as a precursor of a range of antioxidants of variable lipophilicity.

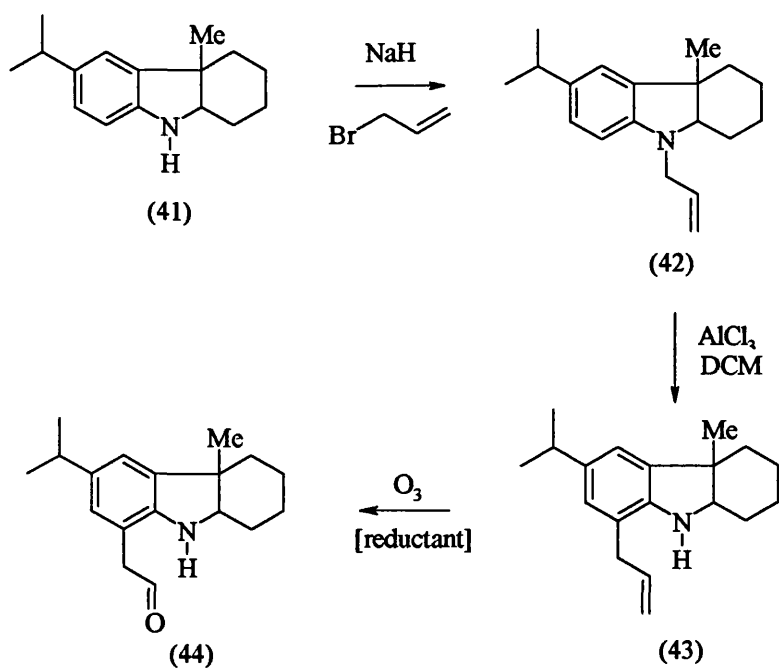

Scheme (29)

Little work has been reported in the literature on the Claisen rearrangement of *N*-allylcarbazoles. Previous unpublished work at Bath<sup>41</sup> shows that treatment of the *N*-allylcarbazole (45) with aluminium trichloride in DCM affords three *C*-allylcarbazoles (46), (47) and (48) in 62%, 24%, and 9% respectively [Scheme (30)].

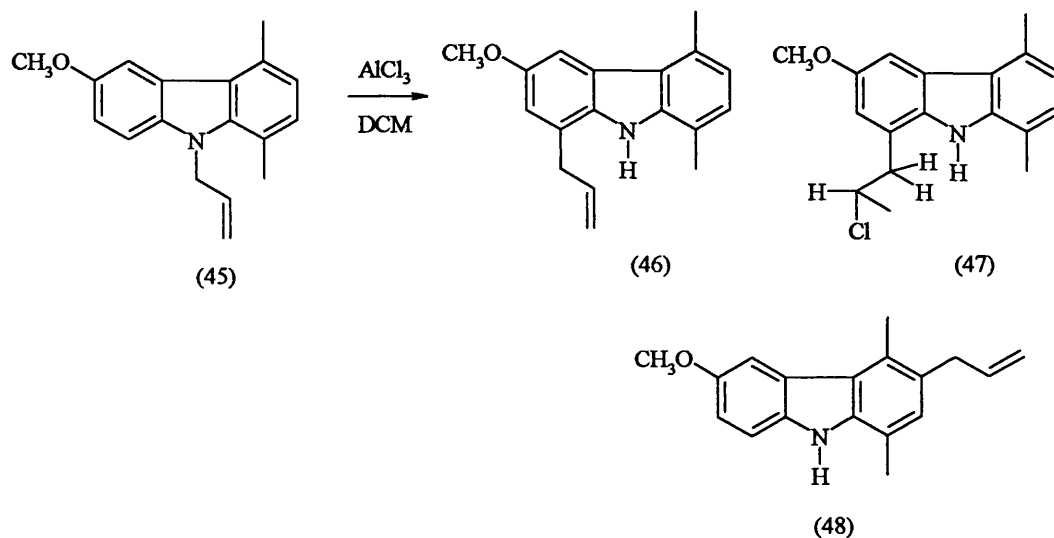

Scheme (30)

Clearly the second product is formed from the first by the addition of hydrochloride and the third is formed either intramolecularly through several rearrangements or an intermolecular process. In our case where there is only one aromatic nucleus a similar reaction should be more straight forward. With this in mind, we attempted to repeat such a reaction upon compound (42).

The *N*-allyltetrahydrocarbazole (42) was prepared successfully by reacting the parent compound (41) with allyl bromide in the presence of sodium hydride. Treatment of (42) with aluminium trichloride in DCM at room temperature, however, afforded only starting material, even when left for 24 h. Repetition of the reaction under several sets of conditions (even under sonication) gave the same result and starting material was recovered quantitatively.

We note that Izumi *et al.*<sup>42</sup> working with indoles have experienced similar results when using aluminium trichloride as a “catalyst”. In this case the problem was overcome however, by changing aluminium trichloride for zinc bromide. It is a distinct possibility that the aluminium salt binds strongly to the indole system. Previous work at Bath<sup>41</sup> for the carbazole example using zinc bromide however, failed to effect a rearrangement.

At this point the experimental work in this area was reassessed and no further effort to resolve this problem was undertaken. We had, of course, shown how to synthesise a similar product through the Heck procedure, but even here future work would be necessary to protect C-4a adjacent to the nitrogen atom. The immediate objective of any further work in this area would thus be to synthesise



compounds of the type (49). The postulated route is shown in the following [Scheme (31)] where X represents a group of variable polarity.

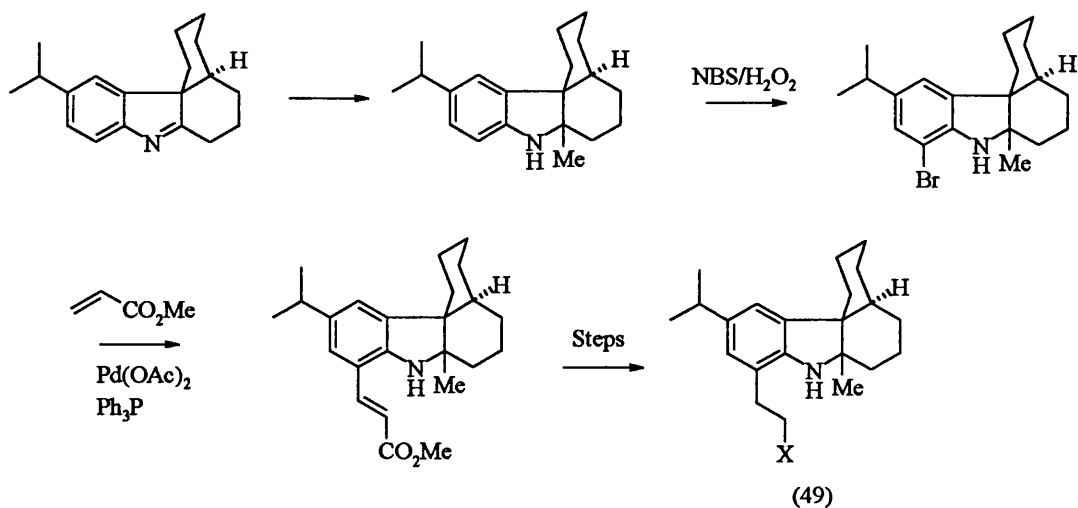

Scheme (31)

Obviously this represents a considerable amount of work and at the end the final products contain three chiral centres. From a pharmacological point of view this is undesirable and our thoughts turned to alternative targets where the problem of chirality is eliminated. It was this which promoted the idea of using a similar molecular template to that of the indolenine (12) and to synthesise achiral spiro compounds of the type (50), where the piperidino nitrogen atom could be used to attach a variety of side chains linked as amide substituents COR.

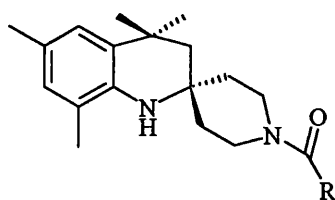

(50)

Before we began work in this area however (Section 3.0), we needed to resolve some aspects of the chemistry of arylimines, which had presented themselves during this and earlier work. In particular, we had accumulated evidence to show that the addition of alkyllithiums to indolenines may not be a simple two-electron process.

### 3.0 Single electron transfer as a mechanistic feature in the alkylation/addition reactions of indolenines

In the course of studying simpler analogues of the tetrahydrobenzocarbazoles (12), our co-workers in Sweden had shown that (51) was an effective chain breaking antioxidant, which binds selectively to low density lipoprotein (LDL) particles in plasma.

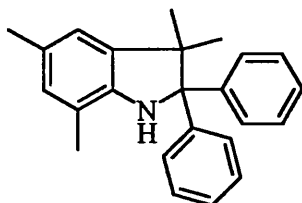

(51)

The mode of synthesis was to form the corresponding imine (52) by a Fischer indolisation reaction between 2,4-dimethylphenylhydrazine and phenyl isopropyl ketone, and then add cyclohexyl lithium. The last reagent was prepared by adding cyclohexyl chloride to *tert*-butyllithium. This reaction did not work well and the best yield of the antioxidant (51) never exceeds 50-60%. Other components in the reaction mixture seemed not to contain the cyclohexyl unit, but rather *tert*-butyl groups and the problem was handed over to the Bath group for resolution. Sainsbury's group soon confirmed that the cyclohexyl group was not transferred to these side products, which were isolated and identified as (53), (54) and (55). Clearly these compounds resulted from the incomplete halogen-metal transfer reaction between *tert*-butyllithium and cyclohexyl chloride, and it was discovered

that treating the indolenine (52) with *tert*-butyllithium alone gave rise to a mixture of (53), (54) and (55) plus other minor products all containing *tert*-butyl groups.

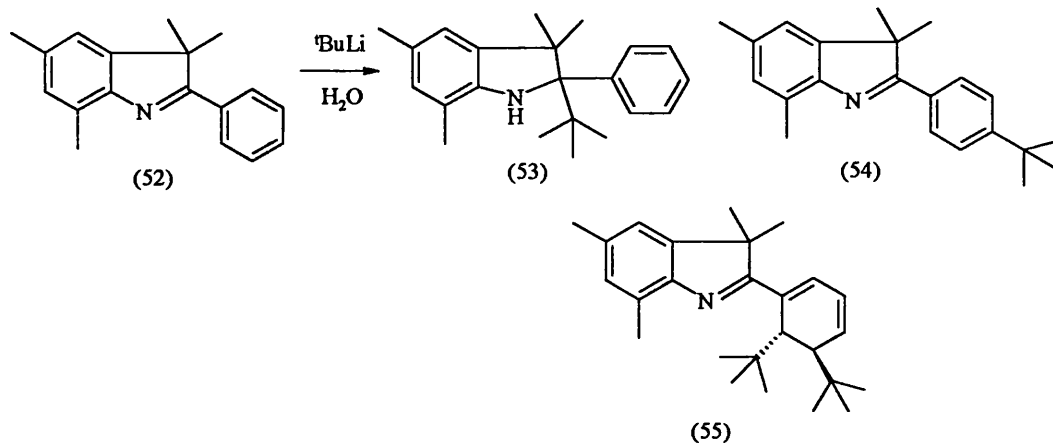

Scheme (32)

To account for the formation of these products it was postulated that the reactions could proceed in two distinct ways:

- (1) Overall nucleophilic addition across the imine double bond to afford the corresponding alkylarylamine (53) as expected and
- (2) Conjugative attack upon the aryl ring to form (54) and (55).

It is thought that both reactions (1) and (2) proceed by a common first step, which involves SET between the alkyl lithium and the imine double bond<sup>43</sup>. This leads to a caged unit containing the alkyl radical, the radical anion of the imine and a lithium cation [Equation (1)]<sup>44, 45</sup>.

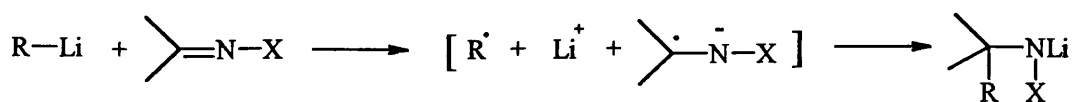

Equation (1)

In the case of imine (52), delocalisation of the radical anion must be a factor, allowing for the rationalisation for the formation of products (54) and (55) as shown.

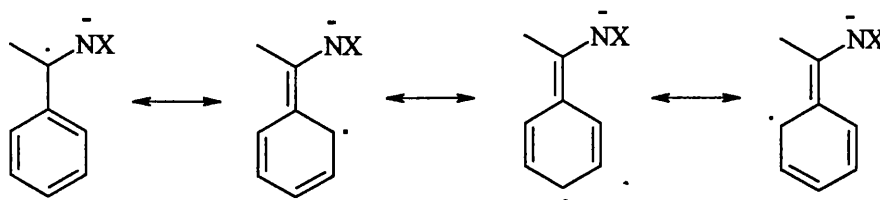

Scheme (33)

It is well known that imines react conveniently with organolithiums and Grignard reagents yielding the halolithium or halomagnesium salts of the resultant addition product: an amine<sup>46</sup>.



Scheme (34)

However, reliable details for such an important reaction are surprisingly scarce. Although the actual structure of Grignard reagents, is still a matter of dispute, extensive studies based upon X-ray crystallography and NMR measurement indicate that metallated alkanes are clearly defined aggregates. While the addition of such reagents to simple imines may be nucleophilic (2-electron) in nature, the reactions of diarylimines are much more likely to involve 1-electron transfer processes, although a distinction between two very rapid single electron transfers and a simultaneous 2-electron reaction is hard to make. For diarylamines we suggest that the second electron transfer is much slower than the first. Here, of course, the initially formed radical anion can gain some stability through resonance. This point will be reinforced later. Certainly there is circumstantial evidence in favour of this type of process since the phenomenon of “conjugative” addition to diarylamines has been known for many years.

Gilman and his co-workers<sup>47</sup>, for example, reported that the reaction of *N*-(2-methoxyphenylmethylene)aniline and phenylmagnesium bromide under “forcing” conditions<sup>48</sup> afforded a product, the structure of which suggests conjugated attack at the position of the methoxyl group as well as addition across the imine double bond.

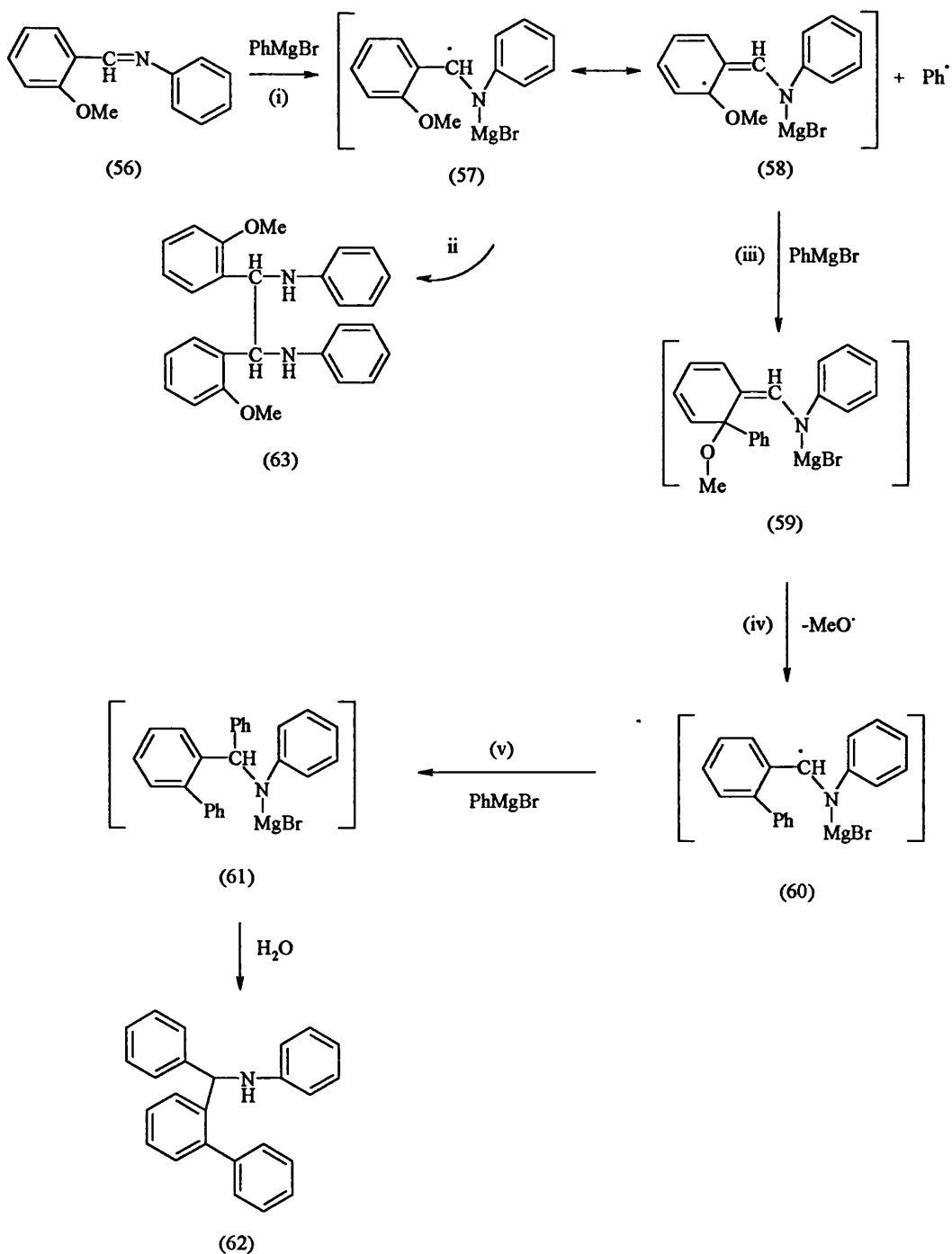

Scheme (35)

One possible explanation of this result is that phenylmagnesium bromide acts as a source of phenyl radicals (probably within a solvent cage). These then attack the methoxylated aromatic ring at an *ipso*-position. Elimination of methoxide radical reforms the imine function to which a conventional nucleophilic addition occurs.

More recent work<sup>49</sup> has confirmed Gilman's work and has also shown that the dimer (63) is formed. Again the last compound can be assumed to form by C-C coupling of the radical anion (57).

With this evidence it is now possible to rationalise what is occurring with the imine (52). We conclude that *tert*-butyllithium reacts with the imine double bond to afford a caged unit containing the *tert*-butyl radical, the radical anion of the imine and a lithium cation as shown (see also equation 1).

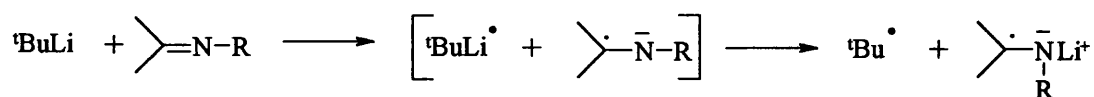

Resonance within the radical anion permits reactions at aryl ring sites and the *tert*-butyl radical then affords the products (54), and (55).

Further evidence for such a single-electron transfer process, comes from the early work of Smith and his colleagues. These workers have shown<sup>45, 50-54</sup> that alkali metals, in an aprotic solvent, combine with imines and alkyl halides to give  $\alpha$ -alkylamines. Originally Smith considered this process to involve the addition of two electrons (from the metal) to afford a dianion. This then reacted with the alkyl halide to displace halide [Scheme (36)].

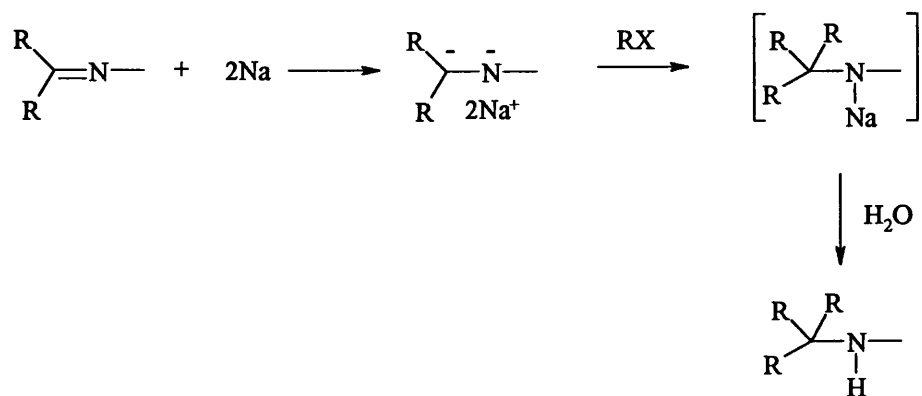

Scheme (36)



Later he revised this opinion and suggested that a single-electron transfer mechanism might operate in certain cases.

This type of reaction suggested to us that a metal/alkyl halide reaction might prove more effective in adding a cyclohexyl unit to the indolenine (52). In fact we decided to use a range of alkyl and alkenyl halides and acetic anhydride in combination with pre-treatment with either sodium, potassium or lithium.

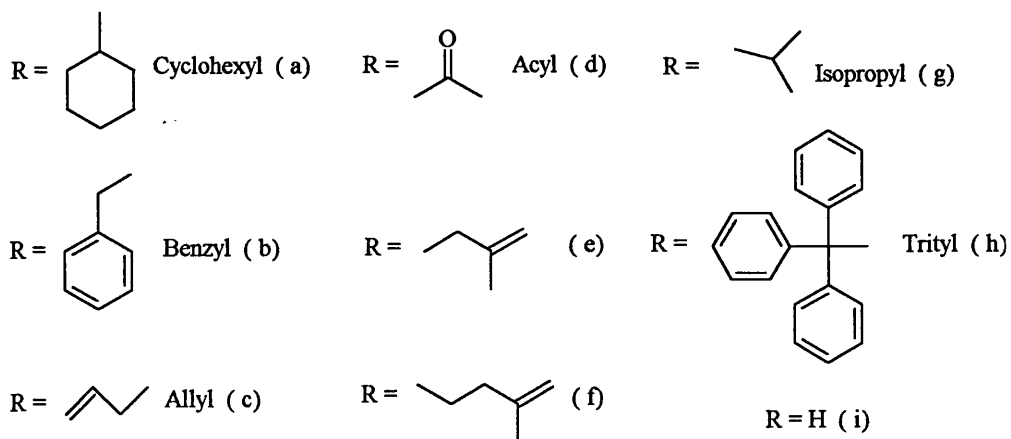
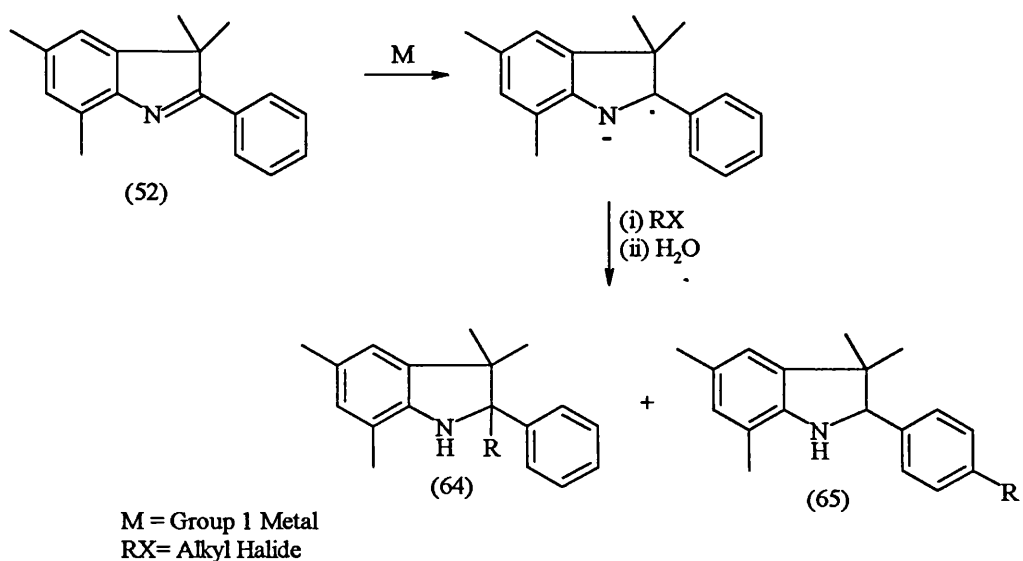

Scheme (37)

In the first series of reactions [Table (1.0)] sodium was used as the electron-donor.

The yields of products, however, are very low:

In addition to the required product we also obtained the conjugative adducts (65) in some cases.

Conditions	Expt no	Alkyl halide	Isolated yield of product(s)
-78°C, 4 eq Na, 4hr	1	Cyclohexyl chloride	(64a), 2%, (65a) <1%
-78°C, 4 eq Na, 4hr	2	Benzyl bromide	(64b) 2%
-78°C, 4 eq Na, 4hr	3	Allyl bromide	(64c) 2%
-78°C, 4 eq Na, 4hr	4	Acetic anhydride	(64d) 2%
RT, 4eq Na, 4hr	5	Isopropyl iodide	(64g) 2%, (65g) <1%
RT, 4eq Na, 4hr	6	Trityl chloride	(64h) 0%
RT, 4eq Na, 4hr	7	$\gamma$ -Dimethylallyl bromide	(64f) 1%
RT, 4eq Na, 5hr	8	Benzyl bromide	(64b) 10%

Table (1)

Following the procedure of Smith and co-workers, the imine (52) was treated with four equivalents of sodium metal as the radical anion generator. After 4 h at room temperature, the black solution was siphoned off from the excess metal. The solution was then cooled to -78°C, before the addition of the halide (experiments (1-4)).

TLC analysis of the reaction mixture normally revealed the presence of three compounds. The major component in each case proved to be starting material. For most reactions another component was the  $\alpha$ -alkylated amine (64i) or an analogue, and the minor component corresponded to the formation of the conjugative addition compound (64). Indeed trityl chloride failed to react, presumably for steric reasons, and only benzyl bromide gave a reasonable yield (10%) of the  $\alpha$ -benzylated adduct (64b).

Such low yields caused us to vary the metal used and the temperature of the reaction, a summary of some of our results is given [Table (2)].

Conditions	Expt no	Alkyl halide	Isolated yield of product(s)
-78°C, 4eq K, 4hr	13	Benzyl bromide	(64b) < 0.5%
RT, 4eq K, 4hr	14	Benzyl bromide	(64b) 0%
-78°C, 4eq Li, 4hr	15	Benzyl bromide	(64b) 1%
RT, 4eq Li, 4hr	16	Benzyl bromide	(64b) 0%
40°C, Xs Na, 5hr	17	Cyclohexyl chloride	(64a) 0%
Reflux, Xs Na, 3hr	18	Cyclohexyl chloride	(64a) > 1%
Reflux, Xs Na, 4hr	19	Cyclohexyl chloride	(64a) 0%

Table (2)

With potassium metal for example 0.5% of the  $\alpha$ -benzylated amine (64b) was formed at -78°C, but none at room temperature.

With lithium the same benzyl bromide afforded 1% of the same product at  $-78^{\circ}\text{C}$ , but none was isolated at room temperature. Changing the alkyl halide to cyclohexyl chloride and the use of sodium at various temperatures (reflux down to  $-78^{\circ}\text{C}$ ) (experiments 1, 7-9) and reaction times gave a maximum 2% yield of the  $\alpha$ -cyclohexyl compound (64a) (at  $-78^{\circ}\text{C}$ ). Although the isolated yields of the adducts were all very low, there did seem to be a general reduction in productivity upon raising the temperature above room temperature. Perhaps this can be attributed to the thermal instability of the radical anion or radicals, but the information we have to support this statement is limited.

Interestingly, modest increases in yields were observed when AIBN was added to sodium mediated reactions (in the presence of light), between the imine and cyclohexyl chloride, benzyl bromide and allyl bromide at  $-78^{\circ}\text{C}$ . However, when benzyl bromide was used at room temperature the addition of the initiator caused the yield of the  $\alpha$ -alkylated adduct to fall from 10% to 5%. If sodium is omitted from the last reaction and AIBN is activated only by light (sunlight or ultraviolet light) no products were isolated.

Conditions	Expt no	Alkyl halide	Isolated yield of product(s)
$-78^{\circ}\text{C}$ , 4eq Na, 4hr, AIBN	9	Cyclohexyl chloride	(64a) 2.7%
$-78^{\circ}\text{C}$ , 4eq Na, 4hr, AIBN	10	Benzyl bromide	(64b) 4.1%
$-78^{\circ}\text{C}$ , 4eq Na, 4hr, AIBN	11	Allyl bromide	(64c) 4.3%
RT, 4eq Na, 4hr, AIBN	12	Benzyl bromide	(64b) 5%

Table (3)

At this point we decided to examine another imine (66), from 2-bromoaniline and 2-methylbenzaldehyde in order to see if an intramolecular cyclisation might occur. One could envisage an intramolecular cyclisation proceeding more readily than an intermolecular one. The anticipated reaction is shown in [Scheme (38)], and should the radical anion react at the C-Br centre, then the dihydrophenanthridine (67) might form. Such a heterocyclic system is present in many alkaloids and biologically important compounds.

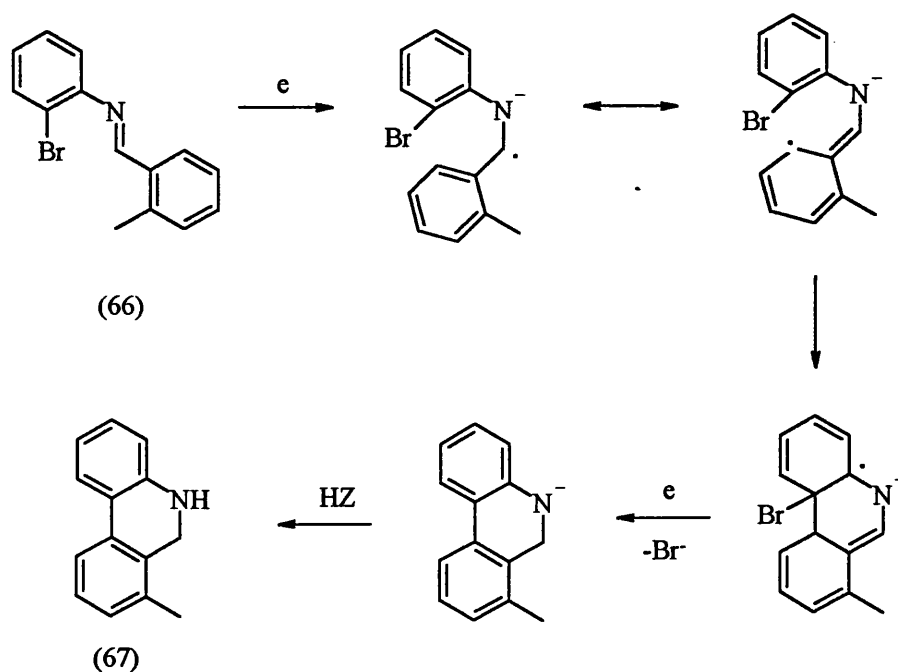

Scheme (38)

In practice however, all attempts at inducing the reaction with lithium or sodium failed. No tangible products could be isolated or detected and complex mixtures were formed. The components of these mixtures proved intractable when subjected to column chromatography.

Due to this apparent lack of control in such reactions it was decided that electrochemistry might be a way forward, since this technique should allow much greater regulation of reduction potential and thereby limit side reactions.

### 3.1 Electrochemistry of imines: an introduction

Electroorganic chemistry provides a convenient and clean method for the generation on a preparative scale of many reactive intermediates. In electrochemistry electrons are regarded as the reagent and the electrode potential thus controls the availability of the reagent. The molecules are activated by the addition or removal of electrons at an electrode. This must involve addition to a LUMO (reduction) or removal from a HOMO (oxidation).

The most important, intermediates formed electrochemically are radical ions, radicals, carbocations, and carbanions. The reactivity of the electrogenerated species is as expected; radical-anions maybe nucleophilic or basic, radical cations are electrophilic, and both may react as radicals to undergo coupling. In this part of the project we hoped to bring about such a coupling reaction between the radical anion of an arylimine and the radical formed from the an alkyl halide. First however, it is necessary to describe some fundamental terms and procedures used to describe and monitor electrochemical processes.

#### Mass Transport

A consideration of modes of transport to, and from the electrode surface within an electrolyte is of practical importance to the electrochemist. Three forms of transport are recognised and can be classified under the headings: diffusion, convection and migration.

## **Diffusion**

Diffusion occurs when localised concentration gradients exist. Entropic forces act to smooth out these uneven distributions of concentration and are therefore the main driving force for this process; normally the larger the gradient the greater the rate of diffusion. Consider a substrate (O) which is oxidised at the electrode surface and forms a chemical product (R). In the region near the electrode where diffusion currents are established (0.003-0.1cm) the concentration of substrate (R) will be less than in the bulk phase and hence the substrate will diffuse towards the electrode surface. On the other hand the product (R) will diffuse away from the electrode into the bulk phase where its concentration is less.

## **Convection**

Convection results from the action of a force on the solution. There are two forms of convection. The first is natural convection, which is present in any solution. This is generated by small thermal or density differences and it acts to mix the solution in a random and therefore unpredictable manner. It is possible to 'drown out' the natural convection effects from an electrochemical experiment by deliberately introducing convection into the cell. This second form of convection is known as forced convection.

## **Migration**

Migration is essentially an electrostatic effect, which arises as a result of applying a voltage across the electrodes. This effectively creates a charged interface. Because of this migratory effect most voltammetric measurements are performed upon solutions, containing an excess of a background electrolyte (e.g. KCl) that does not undergo electrolysis itself, but acts to shield the reactants from such an effect. It should be noted that the purpose of introducing a background electrolyte



into a solution is not however solely to remove migration effects as it also acts as a conductor to lower the internal resistance of the cell.

### **Experimental Cell**

For the majority of electrochemical syntheses, a suitably designed cell is mandatory, but for some, a simple one compartment cell is adequate<sup>55</sup>. The most basic arrangement has both electrodes (the anode and the cathode) immersed in a conducting solution (the electrolyte), which is usually a combination of a solvent and a supporting electrolyte. On applying a potential difference between the electrodes a current flows and electrolysis occurs. This current flow through the system involves firstly, electronic conduction through the external elements of the circuit, followed by ionic conduction. This involves the movement of dissociated ions in solution under the influence of an electrostatic field. Finally, electron transfer occurs either to or from the electrode to the species (M) at the cathode or anode. Clearly, in a one component cell there is the possibility of both cathodic reduction and anodic oxidation of the substrate. To overcome this problem a two compartment cell may be used, in which the sections are divided by a glass frit<sup>55</sup>. This frit is porous enough for ionic conduction, but it is assumed to be insufficiently permeable for diffusion of the substrate.

It is usual to conduct voltammetric experiments using a three electrode system in which a counter electrode (CE) is associated with a working electrode (WE) and a reference electrode (RE). The last is used to monitor the potential of the WE. The usual arrangement is to ensure that current only flows between the WE and the CE. The potential of the WE is often held at a constant value relative to the RE.

Considerations of the electrode 'layout' within the cell must also be noted as yields of products may be affected by poor positioning. For the minimum electrical resistance in the cell the distance between the anode and cathode should be as small as possible

### **Practical requirements**

The essential elements needed for a preparative electrolysis are as follows:

#### **(i) The electrodes:**

The nature of the CE is not critical, providing it is chemically inert under the experimental conditions, a mercury pool or a platinum gauze<sup>55</sup> are commonly employed. The restrictions imposed upon the working electrodes are far greater.

For example in oxidation this limitation is caused by the fact that most metals are themselves oxidised at fairly low electrode potentials. Platinum (and the platinum group metals), however, exhibit good characteristics in this respect and hence maybe used in electro-organic reactions at fairly high electrode potentials, other electrodes such as carbon and lead dioxide<sup>55, 56</sup> have also been commonly used.

For reductions a mercury pool cathode is commonly used<sup>55, 56</sup>.

#### **(ii) The solvent:**

Due to the insolubility of most organic compounds in aqueous media, organic solvents normally form the basis of the electrolyte system. Therefore the ideal electrolyte system must fulfil several requirements.

- It must be electrochemically inert in the potential range of the experiment.
- It must be a good solvent for organic substrates.

- It must be unreactive towards the intermediates present in an electrochemical process.
- It must have a fairly high dielectric constant.
- It must be comparatively easily purified and dried.

Most of these criteria are self explanatory, but the need for a solvent with high dielectric constant is necessary to minimise the electrical resistance of the electrolyte as well as increasing its solubility. Needless to say there are few solvents that fulfil all of these demands, but acetonitrile and DMF<sup>57</sup> are most commonly employed.

**(iii) Background electrolyte and the electrolyte (reactant):**

The restrictions placed on the supporting electrolyte are similar to those for the solvent, but additionally solubility in the solvent is, of course, an important factor.

The most common electrolytes are alkali metal perchlorates<sup>55</sup> and tetra-n-alkyl ammonium fluoroborates or phosphates<sup>55</sup>. These background electrolytes are usually added in high concentration 0.1M to allow a reasonable passage of current through the cell. The reactant itself is typically present in low concentration, say  $10^{-3}$ M.

## **Voltammetry**

### **Introduction**

Voltammetry is one of the techniques that electrochemists employ to investigate electrolysis mechanisms. There are numerous forms of voltammetry, but here we will consider only cyclic voltammetry. For each case, a voltage or series of

voltages are applied to the electrode and the corresponding current that flows is monitored.

### Cyclic Voltammetry

Cyclic voltammetry is a technique that allows one to scan the potential of the working electrode in the anodic (or cathodic) direction and observe peaks due to oxidation (or reduction) of a substrate. The potential can then be scanned in the opposite direction and peaks due to reduction (or oxidation) of intermediates formed during the forward scan may be observed. Ordinarily, an isosceles triangular waveform is used and the potential of the working electrode is varied linearly with time, beginning at point **a** and continuing to point **b** (switching potential) from which the potential is decreased linearly with time to generate the isosceles triangular wave pattern [Figure (10)].

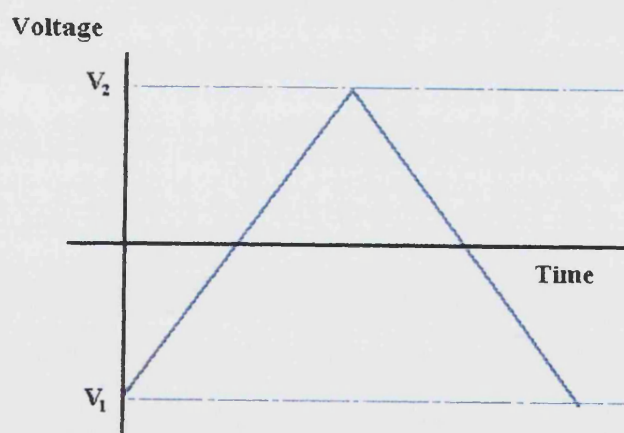

Figure (10)

The current at the peak potential is given by the Randles Sevcik [Equation (2)]:

$$i_p = kn^{2/3}AD^{1/2}C_{\text{bulk}}v^{1/2}$$

Equation (2)

$i_p$  = Peak current/amps

A = Electrode area/cm

$v$  = Rate of potential change/ $\text{vs}^{-1}$

$k$  = Randles Sevcik constant

D = Diffusion coefficient of the electroactive substance/ $\text{cm}^2\text{s}^{-1}$

$n$  = No of electrons transferred in electrode reaction

$C_{\text{bulk}}$  = Bulk concentration of electroactive substance/ $\text{mol cm}^{-3}$

A cyclic voltammogram for a reversible (fast charge transfer) reaction is shown

[Figure (11)] :

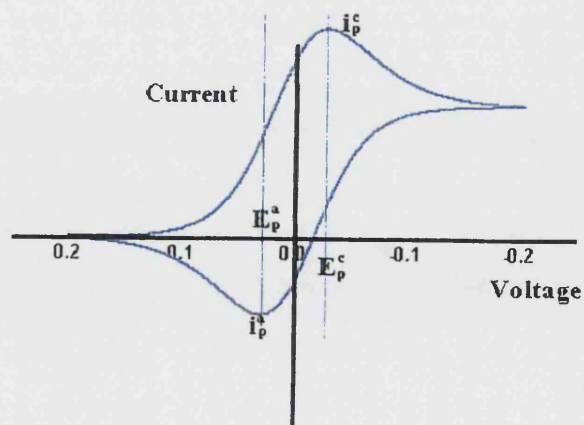
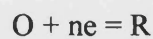

Figure (11)

The starting point **a** is selected such that no current flows when the cell circuit is closed. From point **a** the voltage is scanned in the cathodic direction; as point **b** is reached, reduction of R begins and the current increases with increasing electrode potential until point **c** is reached, where depletion of substrate at the electrode brings about a decrease in current and the observation of a peak.

The direction of the voltage sweep can be changed at point **d** and a peak is observed at **e** on the anodic sweep which corresponds to the oxidation of R. Since there are no coupled chemical reactions, no other anodic peaks are observed and the second cycle differs from the first only slightly due to changes in concentrations of R and O at the electrode.

A cyclic voltammogram for the quasi irreversible (slow charge transfer) reaction is illustrated [Figure (12)]:

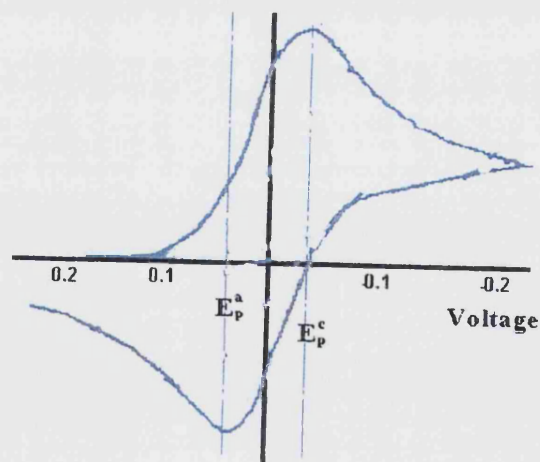
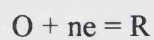
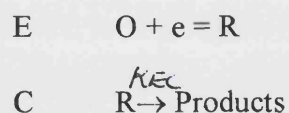

Figure (12)

The form of this voltammogram is identical to the first with the exception that both the peak width and the peak separation are much greater than that observed for the reversible case. The deviation here is a consequence of the fact that a slow charge transfer takes place. Thus the deviation from the reversible voltammogram becomes greater as the voltage sweep rate is increased.

The third general case, reversible reduction of  $O + ne \rightarrow R$  with a coupled chemical reaction (eg EC mechanism), demonstrates the most useful aspect of cyclic voltammetry in the study of organic electrode processes [Figure (13)]:



The [Figure (13)] below shows a cyclic voltammogram for an EC reaction, in this case the electron transfer reaction is reversible and the chemical rate constant  $k_{EC}$  is extremely large.

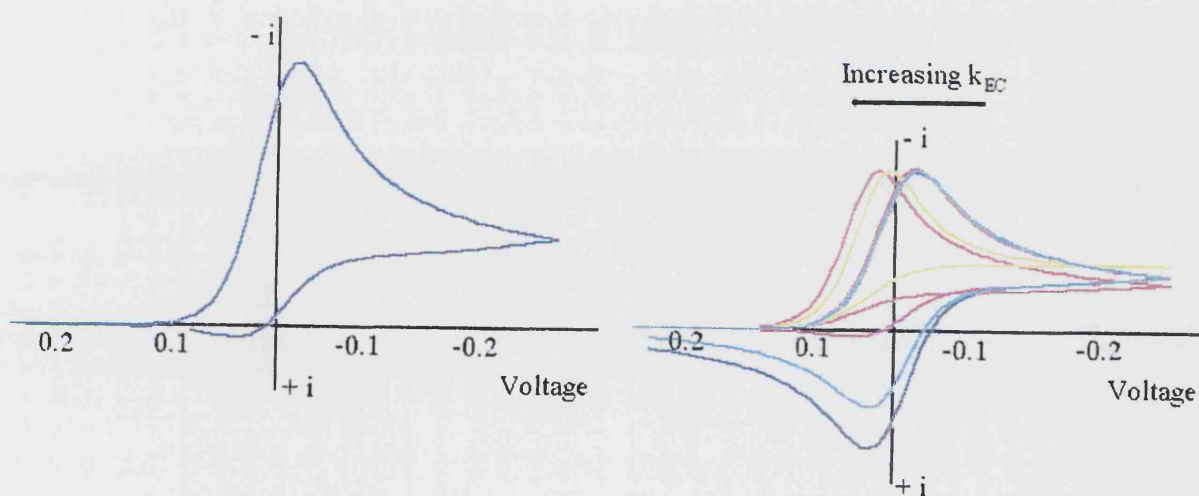

Figure (13)

A notable fact is the reverse peak is reduced in comparison with the forward one. This is because the initial electrolysis product (R) is removed by the fast follow up chemical reaction. Thus, when the voltage is swept back there is little conversion into (O). Obviously if such a cyclic voltammogram is obtained a clearly defined product forming reaction is occurring. Furthermore, as the curves are uncomplicated the product is not itself reduced or oxidised within the range of voltages selected. Had this been the case other reduction and oxidation peaks would be superimposed upon the original trace during the second and subsequent cycles.

It should be noted that the size of the back peak can be explained in terms of the amount of material that reacts during the scan. For very small values of  $K_{EC}$  (R) is essentially unreactive on the timescale of the voltammetric measurement and so no difference is observed between this and the stable reversible electron transfer reaction. As  $K_{EC}$  increases, the size of the back peak begins to decrease due to the removal of (R) by chemical reaction.



### 3.2 Electrochemistry of imines: Results

Nucleophilic attack upon imines can be achieved using many chemical reagents. However, cathodic reduction in the presence of an alkyl halide, which can be reduced to an alkyl radical in the same cell, offers an attractive alternative. Here a wide degree of selectivity should be possible through precise control of electrode potential.

In 1978 Degrand and co-workers<sup>58, 59</sup> reported that pyrrolidine and piperidine derivatives could be synthesised successfully by electrochemical reduction of Schiff bases in the presence of 1, $\omega$ -dibromoalkanes. In particular, the electrochemical reduction of *N*-benzalaniline (68) in the presence of 1,4 dibromobutane afforded 1,2-diphenylpiperidine (69) as shown in [Scheme (39)].

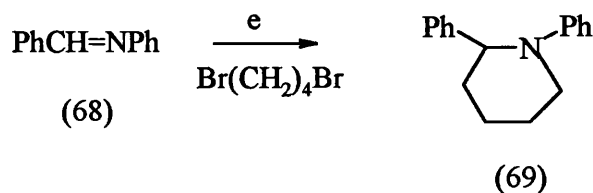

Scheme (39)

Degrad proposed the following mechanism [Scheme (40)] for the reductive cyclisation.

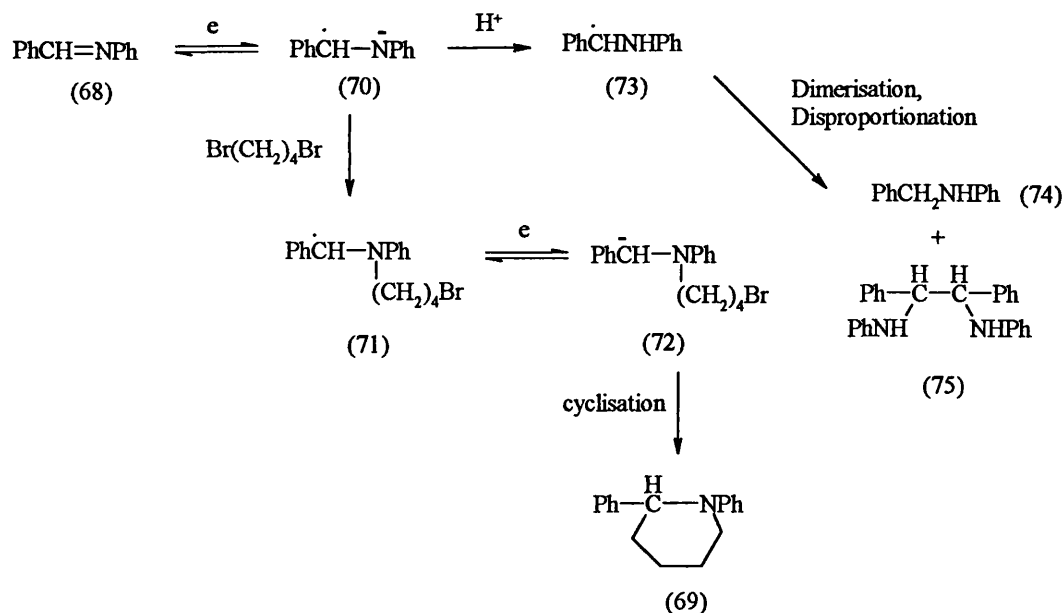

Scheme (40)

It has already been reported by Savéant and co-workers<sup>60</sup> that the *N*-alkylation of the radical anion (70) competes with its protonation by residual water in the solvent. The formation, then the reduction of radical (71) into a cyclic compound is therefore favoured by an increase in the dibromobutane formation.

Degrad seems not to have taken this work further and we believed that we could validate our entry into this.

With this in mind, it was considered necessary for the author to employ the method used by Degrand *et al.*<sup>58</sup> to mimic some of the work already attempted in section (3.0). Initially, it would be necessary to prove that our equipment and experimental conditions were satisfactory; thus it was necessary for the author to repeat Degrand's experiment with *N*-benzaldehyde (68) and 1,4-dibromobutane. In her paper Degrand gave little information was given about the type of cell array used, so our initial set-up employed a typical 2 electrode, 2 compartment synthetic H-type cell [Figure (14)].

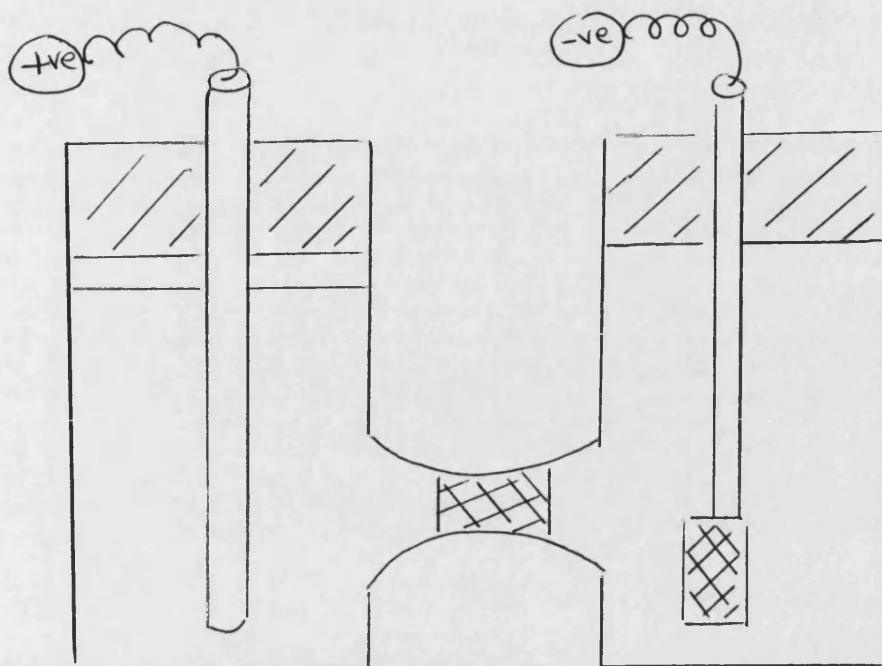

Figure (14)

A flat platinum gauze served as the cathode, previously cleaned in warm concentrated nitric acid. A silver anode was used and the electrolysis was run in DMF with tetrabutylammonium hexafluorophosphate (TBAHFP) as the supporting electrolyte. A ten fold excess of the alkyl halide was added since it had already been noted<sup>58</sup> that a large excess of 1,4-dibromobutane was necessary for an optimal yield of the piperidine (69).

During the course of our experiment a number of problems were encountered (i) The reduction potential of the *N*-benzalaniline (68) (-2.0V) was found to be similar to that at which DMF was reduced. (ii) Platinum gauze has a high resistance, hence this gives rise to a potential drop across the electrode and an overall lack of potential control. These difficulties caused us to abandon the experiment. To circumvent these problems it was necessary to change the experimental set-up so as to define the applied potential more precisely. One idea was to use a system

involving a three electrode arrangement. Indeed, this new set-up gave us an increase in control of electrode potential, and it was possible to run small cyclic voltammograms throughout the course of the experiment. However, we encountered problems in removing the product obtained from the electrode surface and into the bulk solution. To overcome this difficulty, we decided to move a more highly agitated system in the hope that any product made at the electrode would be rapidly transferred into the bulk solution and, in turn, facilitate the movement of substrate to the electrode surface.

The final cell design used a hydrodynamic set-up, where a rotating disc serves as the working electrode [Figure (15)]. The advantage of this is that one can change the rotation speed as necessary, therefore controlling the turnover of reactant at the electrode.

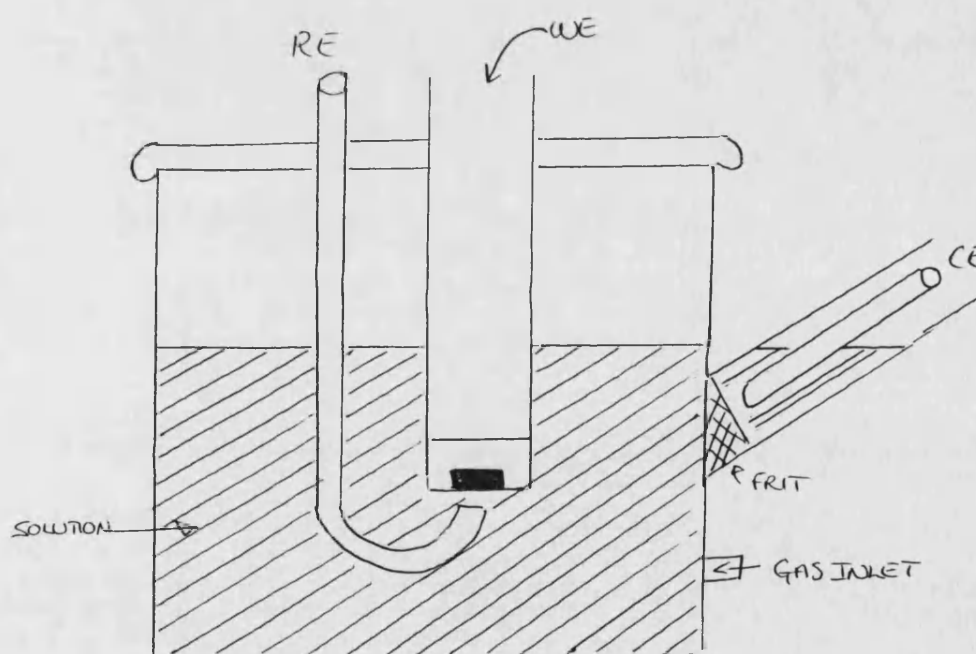

Figure (15)

The rotating disc electrode consisted of a small platinum disc, which was embedded centrally within a large cylinder composed of Teflon (an insulating material). The cylinder was placed in a vessel that contained the reaction mixture and rotated at constant speed. In practice the rotation spins the solution out from the cylinder surface in a radial direction and this movement in turn, draws fresh material in towards the disc.

Before commencing with the experiment, cyclic voltammograms were obtained for *N*-benzalaniline (68) and 1,4-dibromobutane. The cyclic voltammogram of *N*-benzalaniline (68) is shown in [Figure (16)].

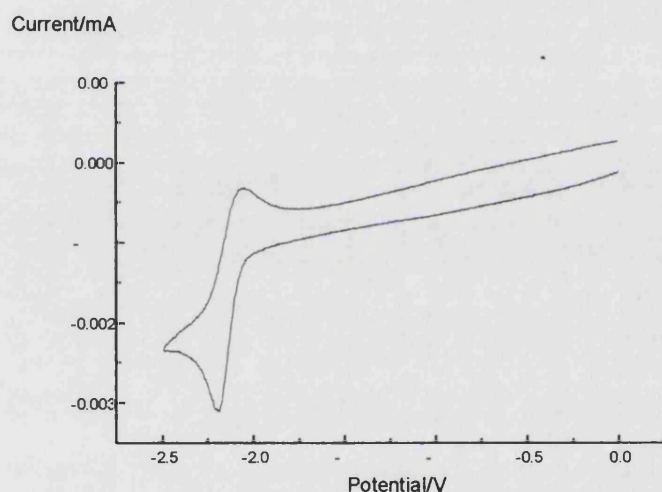

Figure (16)

The shape of this voltammogram is characteristic of a reversible system, as indicated by the almost equal peak heights for the forward and backward scans. It is also possible to deduce that the peak at -2.2V corresponds to a one electron reduction since the peak separation between reduction and oxidation is

approximately equal to 59mV. This value agrees with that predicted by the well known equation<sup>61</sup> (3):

$$E_{p^{ox}} - E_{p^{red}} = 2.218 (RT/nF)$$

Equation (3)

It is thus reasonable to conclude that the peak in the reductive sweep is due to the formation of an anion radical.

The cyclic voltammogram of 1,4-dibromobutane [Figure (17)] on the other hand shows the presence of two peaks at -1.2V and -1.8V. This observation indicates that two reduction events are occurring, neither of which is reversible. We assume that first one bromine and then the other is lost as a bromide ion. Should this be the case, then there is a potential mismatch between that required for the reduction of *N*-benzalaniline (68) and that of the first reduction of 1,4-dibromobutane.

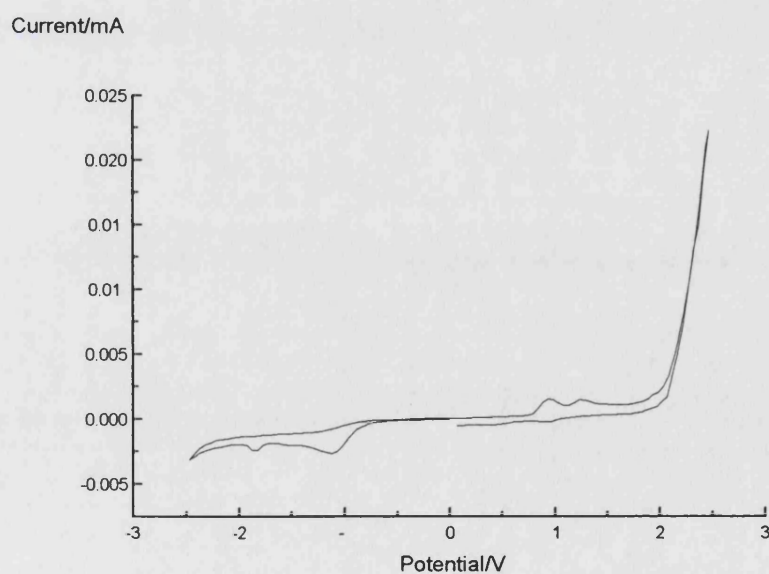
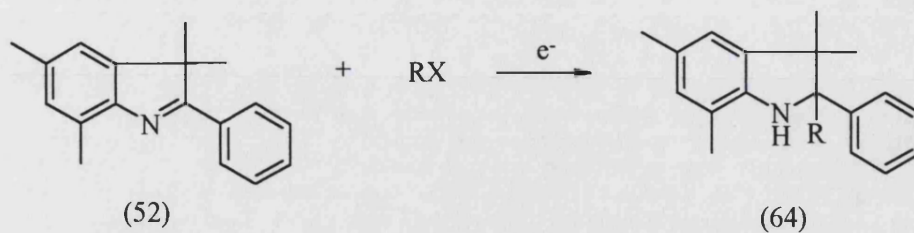

Figure (17)

Nonetheless a preparative electrolysis was run in DMF as solvent, at a platinum rotating disc electrode, rotating at 40Hz with tetrabutylammonium hexafluorophosphate (TBAHFP) as supporting electrolyte. During the course of the reduction the solution turned a deep red colour and this encouraged us to think that a radical process was occurring<sup>51</sup>. After 8 h the catholyte was diluted with water, neutralised, extracted with diethyl ether and the solvent evaporated *in vacuo*. The desired product 1,2-diphenylpiperidine (69) (2%) was isolated, after purification by column chromatography.

Such a poor yield necessitated some investigation of, for example, the effect of solvent, but the use of acetonitrile or THF as replacements for DMF proved unrewarding. No significant improvements were seen when changing the background electrolyte from tetrabutylammonium hexafluorophosphate (TBAHFP) to sodium perchlorate, or to tetrabutylammonium perchlorate (TBAP). Changing the electrode from platinum to lead also proved fruitless, as after 20 min all the lead had decomposed. Using a mercury pool electrode gave rise to no tangible product. In view of these results we decided to stay with our hydrodynamic set-up as described above and address the main reason for our interest, namely the reductive alkylation of the indolenine (52).



R = Cyclohexyl, Benzyl, Isopropyl  
 X = Halide  
 R = H (Reduced compound)

Scheme (41)

Cyclic voltammograms were obtained for indolenine (52) and the respective alkyl halides prior to preparative electrochemical reductions. The cyclic voltammogram of the indolenine (52) shows a single, one-electron redox couple [Figure (18)]. The cathodic potential is approximately equal to  $-2.2\text{V}$ , which as we shall see is rather higher than that of some alkyl halides.

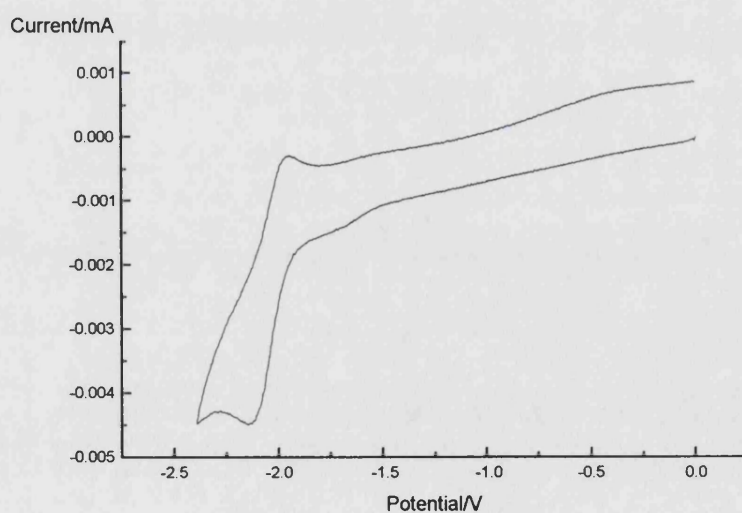

Figure (18)



The reduction potentials of the alkyl halides we selected for a preliminary investigation are shown [Table (4)].

Alkyl halide	$E_p^{ox}/V$	$E_p^{red}/V$
Cyclohexyl chloride	-0.5	-1.1
Benzyl bromide	-1.5	-1.7
Isopropyl iodide	-1.9	-2.25

Table (4)

Hence the application of a voltage of -1.1V, -1.7V and -2.25V, respectively, to each of these halides should give rise to cyclohexyl, benzyl and isopropyl radicals.

A potential of -2.2V would afford the radical anion of the indolenine.

Interestingly, it should be noted that when the indolenine (52) and an alkyl halide (for example isopropyl iodide in the case below) were mixed and the cyclic voltammogram of the mixture was run [Figure (19)], evidence for chemical products is gleaned from the redox couples at +0.9V and +1.2V. The nature of the products responsible for the new peaks could be the required  $\alpha^1$ -propyl indoline (R= <sup>i</sup>Pr). Indeed, if the potential of the cathode is maintained at -2.2V for about a minute the peak intensities at +1.0V and +1.4V increase in size, indicating that a chemical reaction is occurring, after initial reduction of the imine has taken place.

Initial cyclic voltammogram indolenine (52) and isopropyl iodide:

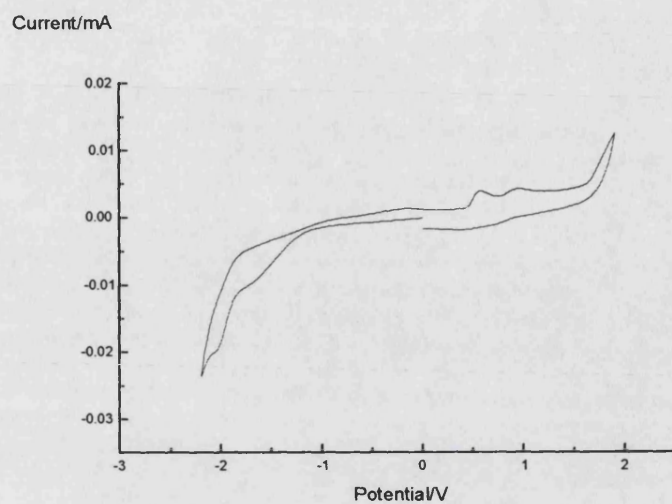

Figure (19)

Indolenine (52) and isopropyl iodide cyclic voltammogram, after 1 min at electrode potential of -2.2V:

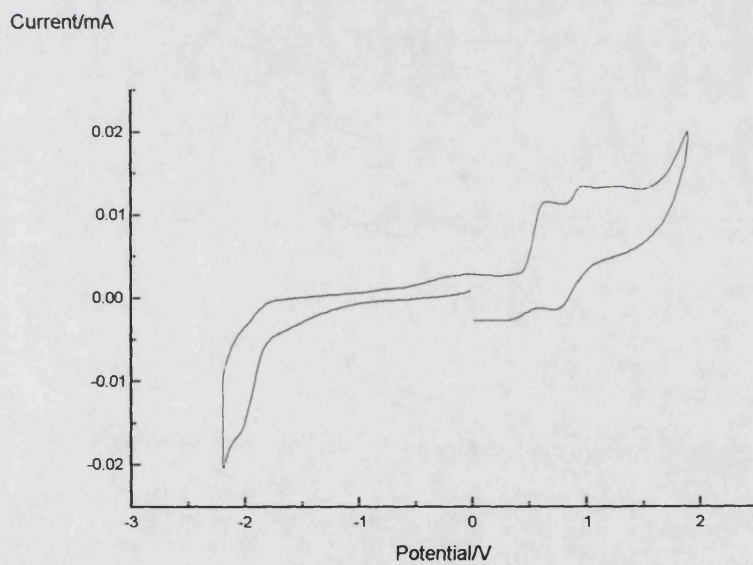

Figure (20)

Despite the fact that the indolenine and cyclohexyl chloride undergo reduction at widely different cathodic potentials, we conducted our first preparative experiment with these compounds. We knew that a potential of a least -2.2V would be required to reduce both species. Applying this potential and rotating the electrode at (40Hz) for 8 h resulted in the solution becoming a deep red colour. On work up, the catholyte afforded a brown viscous oil, which was separated into its components by column chromatography. From this oil, the starting material and the indoline (64, R=H) were obtained, suggesting, as anticipated, that the cyclohexyl chloride forms the cyclohexyl radical. The alkyl radical then combines with another radical before it has time to combine with the indolenine (52). Unaffected by the first reductive step, the indolenine (52) then undergoes reduction to the indoline (64, R=H) at its normal higher potential.

Because cyclohexyl chloride reduces much earlier than the indolenine (52) it was reasonable to change the alkyl halide. Benzyl bromide with a reduction potential closer to that of the indolenine (52) was selected for the next reaction. This was carried out in an identical manner to that described above. At the end of the electroreduction, TLC analysis indicated the presence of the indoline (64, R=H), and unchanged indolenine (52).

In view of this, benzyl bromide was replaced by isopropyl iodide as it is reduced at a potential even closer to that of the indoleine (52). However, once again no  $\alpha$ -alkylated indoline was obtained.

Because of the positive outcome achieved from the initial experiment using *N*-benzalaniline (68) and 1,4-dibromobutane, we decided to replicate the reaction. This time indolenine (52) was selected as the imine and we envisaged that the expected product might be (76) [Scheme (42)].

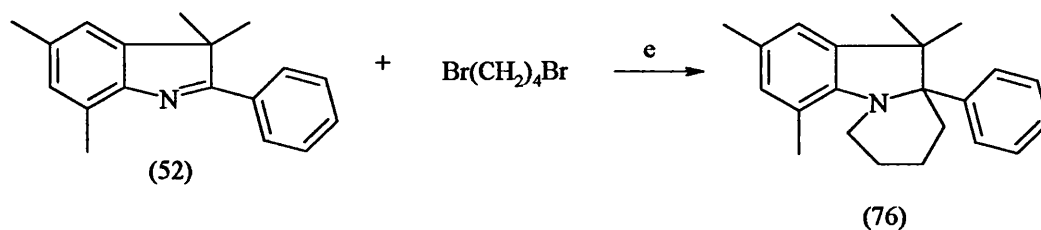

Scheme (42)

The electrolysis was run in DMF, at a platinum rotating disc electrode, rotating at 40Hz with tetrabutylammonium hexafluorophosphate (TBAHFP) as supporting electrolyte. The cathode potential was set at -2.2V and left at this potential until the current had fell to almost zero. Once again the solution turned a deep red colour. After subsequent work up the oily residue was subjected to column chromatography, however, only a trace of a new product (76) was obtained. This material was still impure and the amount available made column chromatography impractical. Nonetheless mass spectrometry showed a molecular ion peak at  $m/z$  305 which is commensurate with that expected for the indoline (76). Unfortunately, due to the impurities  $^1\text{H}$  NMR spectra proved inconclusive. It should be noted that this experiment was repeated several times, varying the length of the electroreduction and the current density. Sadly no better result was obtained.

Due to lack of success in these experiments, it was thought that the reduction might be carried out in a similar manner to that of the chemical one i.e. formation of the imine radical anion first, before the addition of the alkyl halide. Thus, indolenine (52) was reduced at -2.5V for 4 h, then the alkyl halide was added. Once the alkyl halide has been introduced the mixture was then left stirring in the

absence of any applied potential for a further hour. As expected, no products from an interaction of the indolenine and the dihalide were formed. Next the indolenine was reduced at -2.5V for 2.5 h, before addition of the alkyl halide. This time electrolysis was continued for a further 8 h after the dibromide had been introduced. Again no positive result in terms of  $\alpha$ -alkylated indoline product was observed and only the indoline (64, R=H) was identified in the reaction product.

It should be noted that the experiments were also repeated using a sodium salt as the background electrolyte, in an attempt to make the experimental conditions as similar to the chemical reduction as possible. No improvement was noted.

The failure of the indolenine (52) to undergo coupling with an alkyl halide was somewhat puzzling as products had been isolated previously albeit in low yield using the chemical approach. At this point we wondered whether the failure to effect such a reaction could be due to some inherent factor associated with the chemical reaction. One possible explanation is that in the chemical experiment, the alkali metal may provide a surface that can help to stabilise the reactive intermediates produced, as well as bringing the two reactive species closer for coupling.

Undeterred by negative results we decided to investigate one final reaction on another substrate where possible coupling would be intramolecular as opposed to intermolecular as demonstrated in [Scheme (43)].

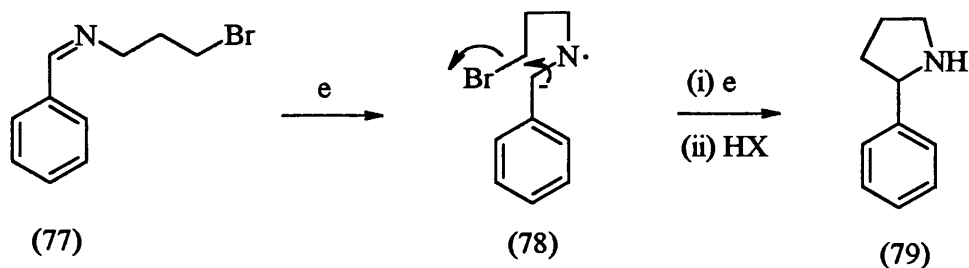

Scheme (43)

If reduction of the imine to the radical anion (78) could be induced to occur before reduction of the C-Br bond then we might anticipate the formation of the pyrrolidinyl radical. This should undergo rapid reduction to the anion and eventually give 2-phenylpyrrolidine (79) on work up. Other possible products might include the dimer (80).

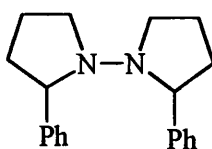

(80)

From the cyclic voltammetry of the indolenine (52) a reversible couple was observed where  $E_p^{ox} = -2.0V$  and  $E_p^{red} = -2.2V$ . The reaction was repeated several times using a similar setup to that employed previously. In a preparative electrolysis attempt a deep red colour was produced as soon as current passed through the cell. Once the cell current fell to virtually zero the catholyte was worked up, but it was clear from thin layer chromatography, that a multi component mixture had been formed. Despite a week of labour none of these

components were obtained in sufficient amounts, or sufficiently pure, for characterisation. At this point it was decided that a chemical synthesis of some achiral antioxidants would be more rewarding and further work in the electrochemical area was not progressed.

## 4.0 Piperidinotetrahydroquinolines

The first achiral targets considered were the piperidinotetrahydroquinolines .

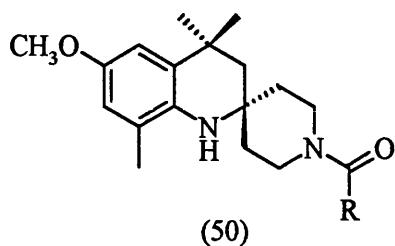

- R=CH<sub>3</sub> (a)
- R=(CH<sub>2</sub>)<sub>5</sub>CH<sub>3</sub> (b)
- R=(CH<sub>2</sub>)<sub>10</sub>CH<sub>3</sub> (c)
- R=(CH<sub>2</sub>)<sub>7</sub>CHCH(CH<sub>2</sub>)<sub>7</sub>CH<sub>3</sub> (d)
- R=CH<sub>2</sub>C(CH<sub>3</sub>)<sub>2</sub>CH<sub>2</sub>CO<sub>2</sub>H (e)
- R=(CH<sub>2</sub>)<sub>6</sub>CH<sub>2</sub>(CHCHCH<sub>2</sub>)<sub>3</sub>CH<sub>3</sub> (f)
- R=CH<sub>2</sub>PhCH<sub>2</sub>CHCONHCOS (g)

In these compounds the 4-methoxytetrahydroquinoline unit is assumed to be the locus of oxidation and the acid residue (RCO-), which is infinitely variable, could be used to fine tune the lipophilicity and selectivity of the antioxidant. Non-chirality is ensured by the spirocyclic nature of the sp<sup>3</sup> carbon atom  $\alpha$ - to the quinoline nitrogen atom.

It should be noted that the benzylic *gem* dimethyl groups are necessary to ensure that the ensuing radical cation, or radical, is not quenched by attack at this site by a nucleophile or a radical, respectively.

The piperidino compounds were chosen specifically to allow us to investigate structure/activity relationships, especially as the nature of the *N*-acyl side chain could be varied in subtle ways in order to home in on the optimum selectivity for LDL.



In order to advance these objectives it was necessary to synthesise a good supply of 6-methoxy-4,4,8-trimethylspiro[piperidine-4,2-(1,2,3,4-tetrahydroquinoline)] (86). The route selected is outlined [Scheme (44)].

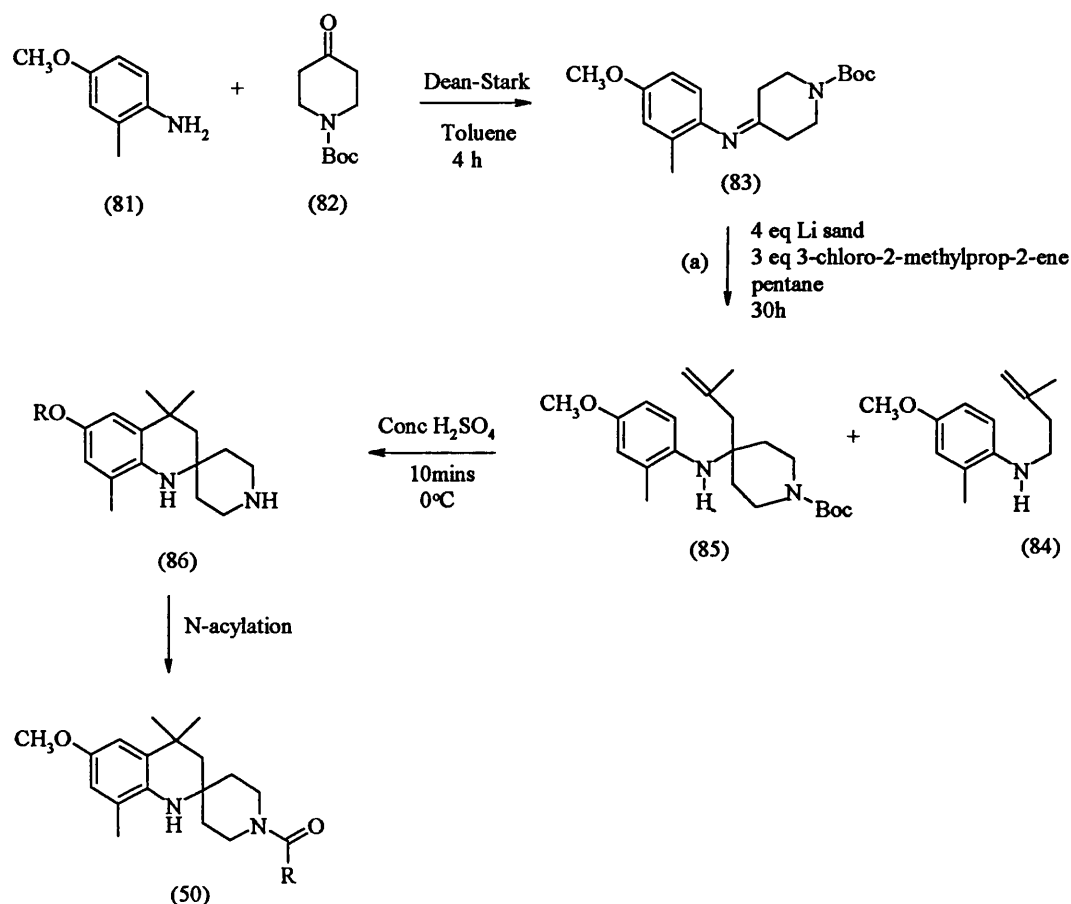

Scheme (44)

Condensation of the commercially available *N*-Boc protected piperidone (82) with 4-methoxy-2-methylaniline (81) was achieved using standard Dean-Stark conditions (in toluene). The resultant imine (83) was obtained in 95% yield and was pure enough to be used directly in the subsequent step.

The next step (a) proved more challenging. A one pot reaction between the imine (83), lithium sand, and 3-chloro-2-methylprop-2-ene in pentane afforded the desired compound (85), but only in 31 % total yield.

As the low yield might be a result of incomplete formation of the required 2-methylallyllithium reagent, we decided that we should prepare it independently in a separate step. Its purity could then be checked before addition to the imine. For this we planned to react a known amount with benzaldehyde in the anticipation of forming either the secondary alcohol (87) or its dehydration product (88).

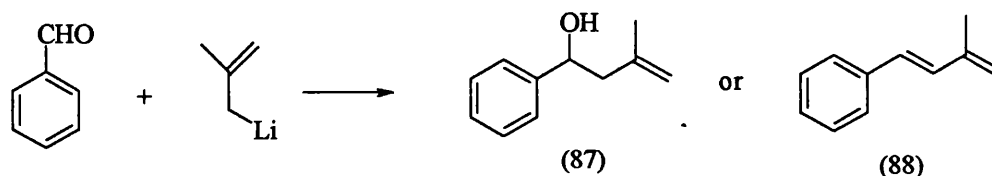

Scheme (45)

The lithium alkenyl was prepared by treating 3-bromo-2-methylprop-2-ene in diethyl ether with lithium sand over a protracted period 30 h. When this was done and the solution quenched with benzaldehyde the alcohol (87) was formed in quantitative yield. Now when the reagent was prepared again and added to the imine no reaction occurred. Clearly the problem is here not with the reagent, but rather with the lack of reactivity with the imine.

It is well known that the addition of organometallic reagents to imines is often accompanied by competitive enolization/reduction and/or bimolecular coupling reactions due to relatively poor electrophilicity of the imine carbon and the competing loss of the  $\alpha$ -proton<sup>62-66</sup>. In general, imines derived from enolizable

aldehydes and ketones undergo exclusive enolization on treatment with alkyl Grignards.

To circumvent these problems, a number of methods have been developed<sup>67-76</sup>. The strategy most commonly employed has involved activation of the imine carbon to nucleophilic attack by co-ordination of a Lewis acid to the nitrogen lone pair<sup>68, 70, 71</sup>.

With this in mind we wondered if the low yield of the product (85), is due to partial enolization, instead of the desired nucleophilic addition [Scheme (46)].



Scheme (46)

In view of this, the reaction was repeated in the presence of an equimolar of zinc chloride, but this did not improve the required addition.

We note that Imamoto and his collaborators<sup>77, 78</sup> report success when organocerium reagents, prepared *in situ* from cerium(III) chloride and organomagnesium or organolithium reagents, are added to carbonyl compounds. In particular, it is claimed that these less basic reagents, react in good yields with those carbonyl compounds which are prone to side reactions, such as enolization.

Terashima *et al.*<sup>79-81</sup> have also reported similar results when treating organocerium reagents with imines.

We decided to follow this work up and to carry out the reactions shown [Scheme (47)].

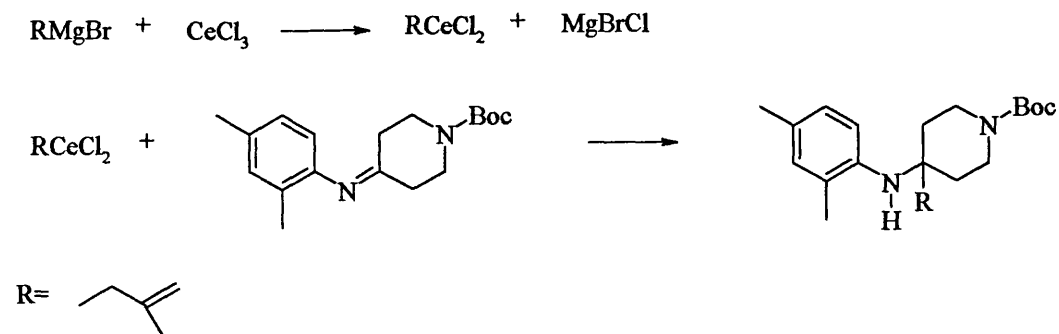

Scheme (47)

Using a procedure recommended by Kaesz<sup>82</sup> we formed the Grignard reagent from 3-bromo-2-methylprop-2-ene and reacted it with cerium trichloride, but when this was combined with the imine, following Imamoto's conditions only the imine was returned.

While this research was being undertaken another group<sup>83, 84</sup> reported similar difficulties when attempting the additions of organolithiums and organomagnesium bromides to imines in diethyl ether as solvent. For some unexplained reason these authors noted an increase in yield from 0 to 80% for the reaction of organomagnesium bromides to imines when the solvent was changed to toluene. However, in our case, such a switch was not advantageous and the best yield of the adduct (85) was only 15%.

Several weeks had now been expended on this problem and we concluded that we were only tinkering with at least two processes in equilibrium. It seemed appropriate to push on and accept that 31% was a reasonable yield of the adduct after all.

The next step in our projected synthesis was acid catalysed ring-closure. Previous work in the Department had shown that concentrated sulfuric acid is a satisfactory

reagent for this type of cyclisation and we assume that if it proceeds by initial protonation of the alkene side chain chemoselectivity is ensured as protonation at the terminal position gives a tertiary cation as an intermediate. Indeed, it is unlikely that anything other than a quinoline should form eventually, unless rearrangement of the double bond occurs. One effect of using strong acid as reagent is that the *N*-protecting group was removed during the reaction.

The key intermediate (86) (R=Me) was obtained successfully (60%), along with the *O*-demethyl derivative (86) (R=H) by cyclisation of aniline (85) using concentrated sulfuric acid.

Once isolated, we attempted to synthesise some *N*-acylated derivatives from (86, R=Me) using a variety of coupling reagents. The first analogues to be investigated were compounds (50, a-d).

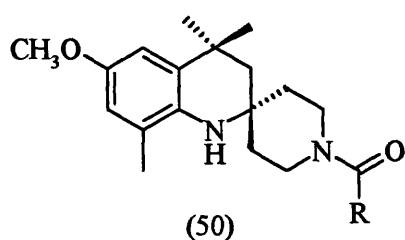

- R= CH<sub>3</sub> (a)
- R= (CH<sub>2</sub>)<sub>5</sub>CH<sub>3</sub> (b)
- R= (CH<sub>2</sub>)<sub>10</sub>CH<sub>3</sub> (c)
- R= (CH<sub>2</sub>)<sub>7</sub>CH=CH(CH<sub>2</sub>)<sub>7</sub>CH<sub>3</sub> (d)

Treatment of the amine (86, R=Me) and the appropriate acid chloride in the presence of 4-dimethylaminopyridine (DMAP) and triethylamine afforded the compounds (50, a-c) in moderate yields of 28, 38 and 95 % respectively.

Of course, there are two basic amino centres in the spiro-tetrahydroquinolines, but one of these is an anilino type, far less reactive than the piperidino unit. The selection of these three amides rested on the fact that we wished to investigate structure-activity relationships with derivatives containing side chains of increasing

length, but from computer modelling studies it soon became apparent that simply increasing the length of the saturated alkyl chain allowed the chain conformational flexibility instead of remaining rigid. Since we wanted the ionisable portion of the compound to be freely accessible, it seemed necessary to synthesize the analogue (50d) where the flexibility of the chain is reduced by the inclusion of a double bond. Reacting amine (86) with oleoyl chloride using similar conditions as previously applied to compounds (50 a-c) resulted in the formation of the desired compound (50d) in 10 % yield.

Our next objective was to prepare two compounds, which would contain a similar functionality to the components of a known material "Tarabetic". Although designed as a drug for diabetes Tarabetic is also believed to act as an antioxidant. It contains  $\gamma$ -linoleic acid (89) which is considered to be the key active ingredient.



(89)

With this in mind, it was deemed necessary for the author to prepare one compound containing an acid function, whilst the other should incorporate a linoleic side chain as shown:

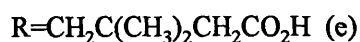
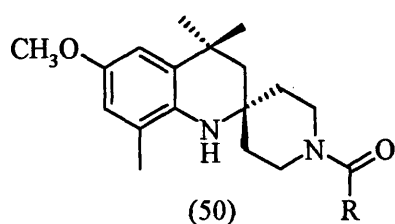

The first compound (50e) was prepared successfully in 10% yield by reacting the amine (86) with 3,3-dimethylglutaric anhydride in the presence of DMAP and triethylamine in DCM.

The second compound (50f) was synthesised by treating amine (86) with linoleic acid in the presence of 1,3-dicyclohexylcarbodiimide (DCC)<sup>85</sup>. Such a coupling reagent has been used with much success in the formation of peptides<sup>86</sup>. The mechanism for the reaction is shown [Scheme (48)].

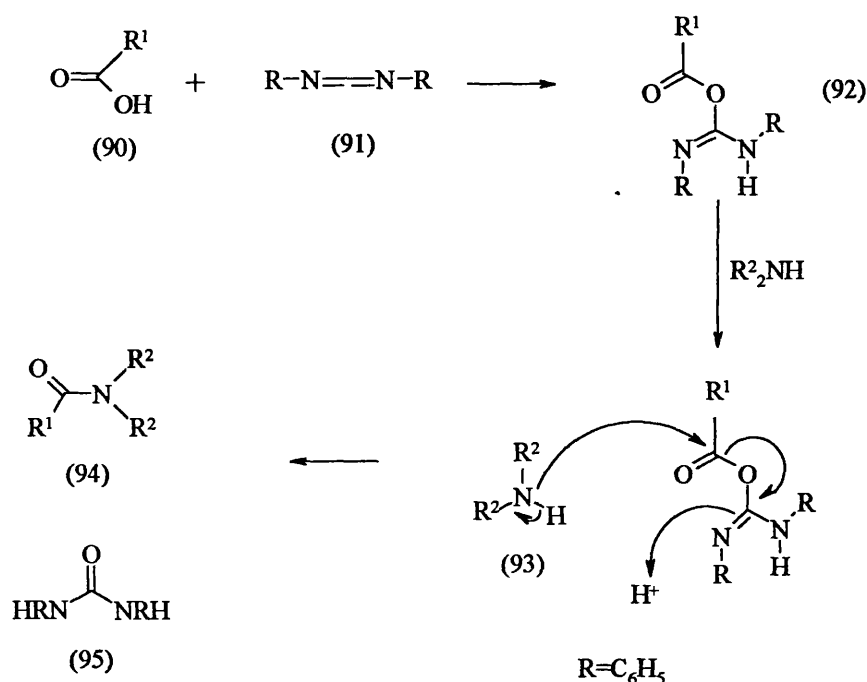

Scheme (48)

Analogue (50f) was initially isolated in 16% yield, but was found to be highly contaminated by dicyclohexyl urea. This by-product however, this could be removed by washing the product with cold ethyl acetate.

It should be noted that little attempt was made to optimise the yields of all the amides since only small quantities of the products were required for biological testing.

At this point a company called Eirex approached us wishing to bring together work on antioxidants and diabetes. This company was extremely interested in evaluating the amides we had just synthesised and encouraged the University of Bath to patent the possible application effects of them. They paid for the cost of the patent application, which was duly filed and reserved the right to licence the patent if the compounds showed useful properties in their tests. The compounds themselves were evaluated at the University of Cork, but none of them showed sufficient activity against diabetes and other indications to warrant follow-up work. Thus the project was dropped.

Unfortunately for us in the process of assessment at Cork all of our stocks of the amides were consumed and we still do not know how these compounds might have behaved in a trial specifically designed to assess their selectivity for LDL.

The work with Eirex focussed our attention on diabetes and in particular upon the drug troglitazone (96), which in addition to its action against this condition also inhibits cholesterol biosynthesis<sup>87</sup>.

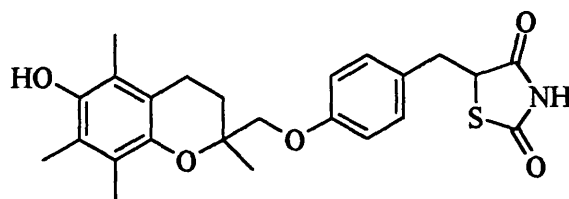

(96)



It seemed to us that the main structural unit of troglitazone might also serve as a *N*-substituent of the piperidino group of the spiro tetrahydroquinolines.

Consequently we took on the synthesis of the amide (50g) and attempted the reaction sequence shown [Scheme (49)].

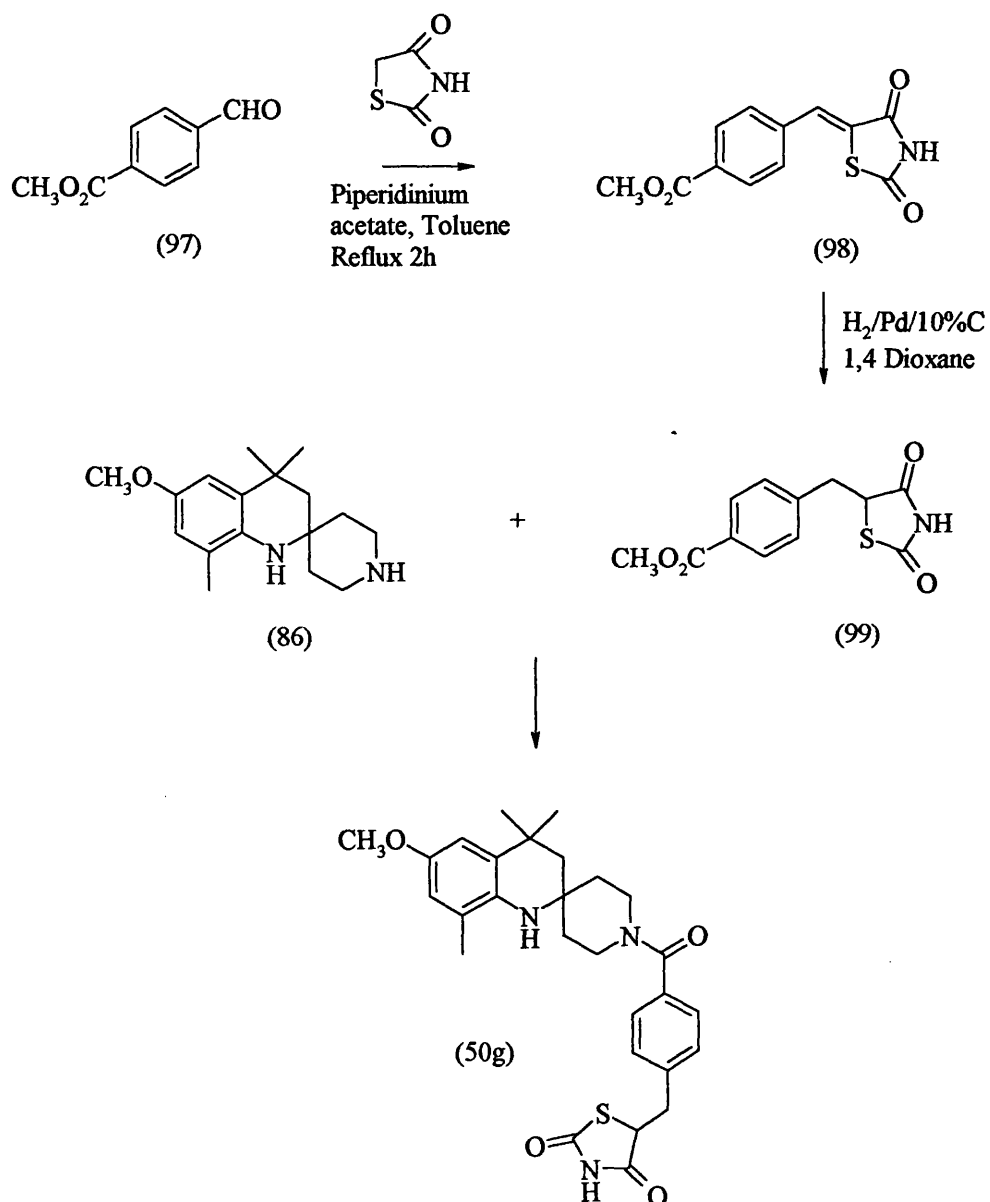

Scheme (49)

The 2,4-thiazolidinedione (98) was prepared in high purity (98%) by a Knoevenagel condensation between methyl 4-formylbenzoate and 2,4-thiazolidinedione in boiling toluene, using a catalytic amount of piperidinium acetate.

Once obtained, the product was hydrogenated to give the benzyl-2,4-thiazolidinedione (99) in 72% yield.

Having formed the two halves of our target molecule we were now in a position to attempt a coupling between them. In 1996, Gotor and co-workers<sup>88, 89</sup> reported success using *Candida antarctica* Lipase (CAL) as a catalyst for the asymmetric amidolysis of (100), affording the enantiopure monoamidation product (101) in high yield.

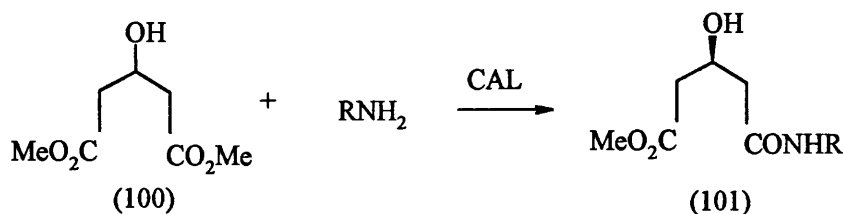

Scheme (50)

We decided to use a similar enzymatic approach to effect coupling on our substrate as shown [Scheme (51)]. However, this failed and a TLC analysis of the reaction mixture only revealed the presence of unreacted starting material. Other enzymes<sup>90</sup> recommended for similar types of couplings were also tried, but the results were all the same.

We are unsure why this reaction failed, although we recognised that our substrates are much more complicated than those normally used in enzymic amidolysis reactions.

Attempts to combine the benzyl-2,4-thiazolidinedione with the piperidine (86) using sodium hydride to deprotonate the latter were also unsuccessful and a quantitative amount of unreacted tetrahydroquinoline was returned after work up.

We were unsure of the reason for this failure and decided to move to an alternative approach. In particular, we decided to hydrolyse the ester (99) to the corresponding acid (102). Once prepared, we anticipated using a peptide coupling reagent to afford the desired Troglitazone analogue (50g).

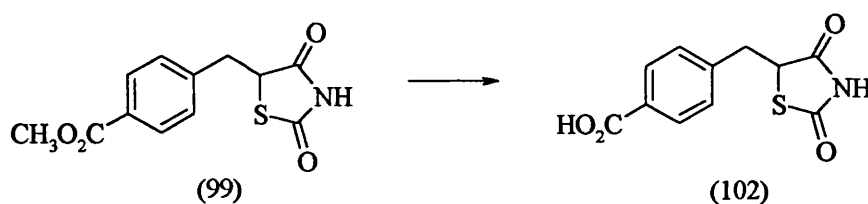

Scheme (51)

In order to achieve our goal, we reacted benzyl-2,4-thiazolidinedione (99) with a dilute aqueous solution of sodium hydroxide. However, these conditions proved too harsh as further degradation occurred. From <sup>1</sup>H NMR we noted that the thiazolidine ring was no longer intact and it seemed possible that the mercaptoamide (103) had formed. Enzymatic hydrolysis conditions were also attempted but these also failed.

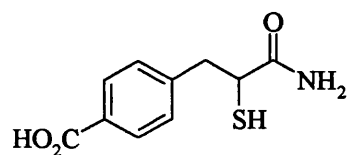

(103)

The final approach was to treat the ester (99) with trimethylsilane iodide (TMSI), followed by subsequent hydrolysis. Such a reaction was first reported by Olah<sup>91</sup>. With our substrate, however, the ester group remained unreactive and even after a reaction time of 35 h in boiling acetonitrile work up gave an almost quantitative return of starting material.

As a consequence of the negative results obtained so far, we decided to move to the benzyl ester<sup>92</sup> as one could envisage the ester group being cleaved during the hydrogenation step as shown [Scheme (52)].

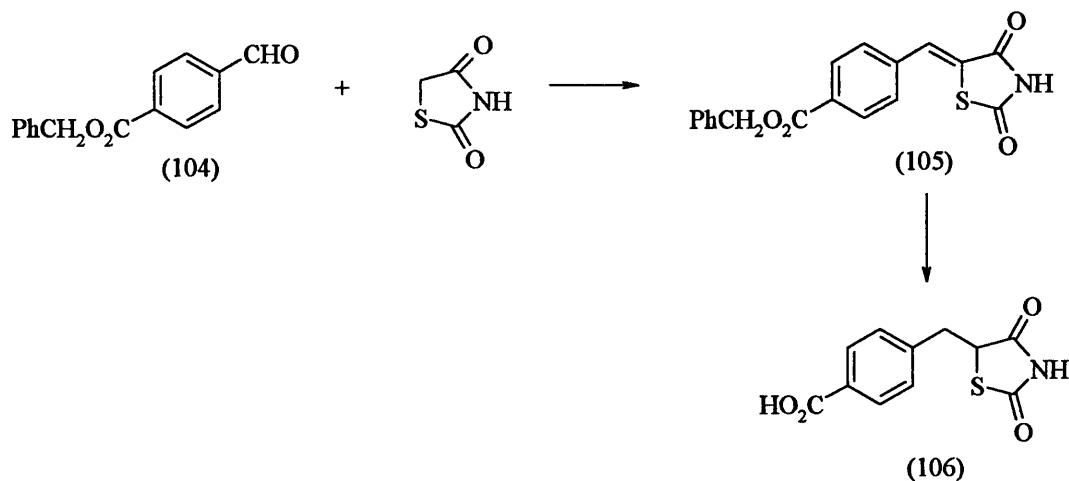

Scheme (52)

Initially, following the procedure of Hassner<sup>93</sup> we reacted 4-formylbenzoic acid with benzyl alcohol in the presence of DCC and a catalytic amount of *N*-pyrrolidinopyridine in DCM. The desired ester (105) was obtained pure in 10% yield although originally it was contaminated with dicyclohexyl urea. Next 4-formylbenzoic acid was treated with sodium hydrogen carbonate and then with benzyl bromide. The desired benzyl ester (105) was isolated in 28% .

More traditional methods of esterification might well have been assessed, but in the meantime we attempted a Knöevenagel reaction between it and the thiazolidinedione. The initial reaction was one in which benzyl 4-formylbenzoate and 2,4-thiazolidinedione were heated in toluene with a catalytic amount of piperdinium acetate. Previously when the methyl ester (99) had been used the condensation worked well. Now the analogous reaction failed. It is probable that the benzyl ester is susceptible to enolisation under the basic conditions we employed and a self-aldolisation-type process is now competitive with condensation with the thiazolidinedione.

At this point the news from Eirex about the simpler amides was relayed to us and the author was instructed not to pursue this particular work further.

## 5.0 The Imidazolidines

One problem we continually faced in previous work was low yields in key reactions. Thus, we wanted to devise a high yielding route to antioxidants that would enable us to obtain rapidly reasonable amounts of materials for biological assessment. We were therefore attracted to the benzimidazoline system as a replacement for the tetrahydroquinoline unit. In particular, we considered compounds of the type (107), where the oxidisable “head” is the 1,2-phenylenediamine moiety and the lipophilic tail is a spiropiperidine assembly as before.

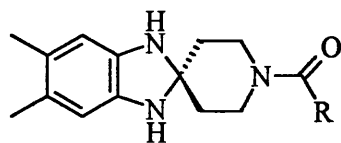

(107)

Benzimidazolidine derivatives are often synthesised by a dehydration condensation reaction between 1,2-phenylenediamine and carbonyl compounds. It is known that this reaction is reversible and removal of generated water is required to complete the reaction. Aldehydes are common co-reagents in the cyclisation, but in general ketones are much less useful. However, imidazolidine formation has been reported when ethylenediamine is treated with cyclohexanone<sup>94</sup>. In our hands we attempted to react the phenylenediamine (108) with the piperidone (109) under Dean-Stark conditions in the anticipation of forming the imine (110). Once formed, one could imagine that cyclisation of the imine might occur under the

appropriate conditions to afford the key intermediate (112). After isolation, deprotection and peptide coupling with an appropriate substrate we might thus obtain a complementary series of potential antioxidants related to the more inaccessible spiro-tetrahydroquinolines.

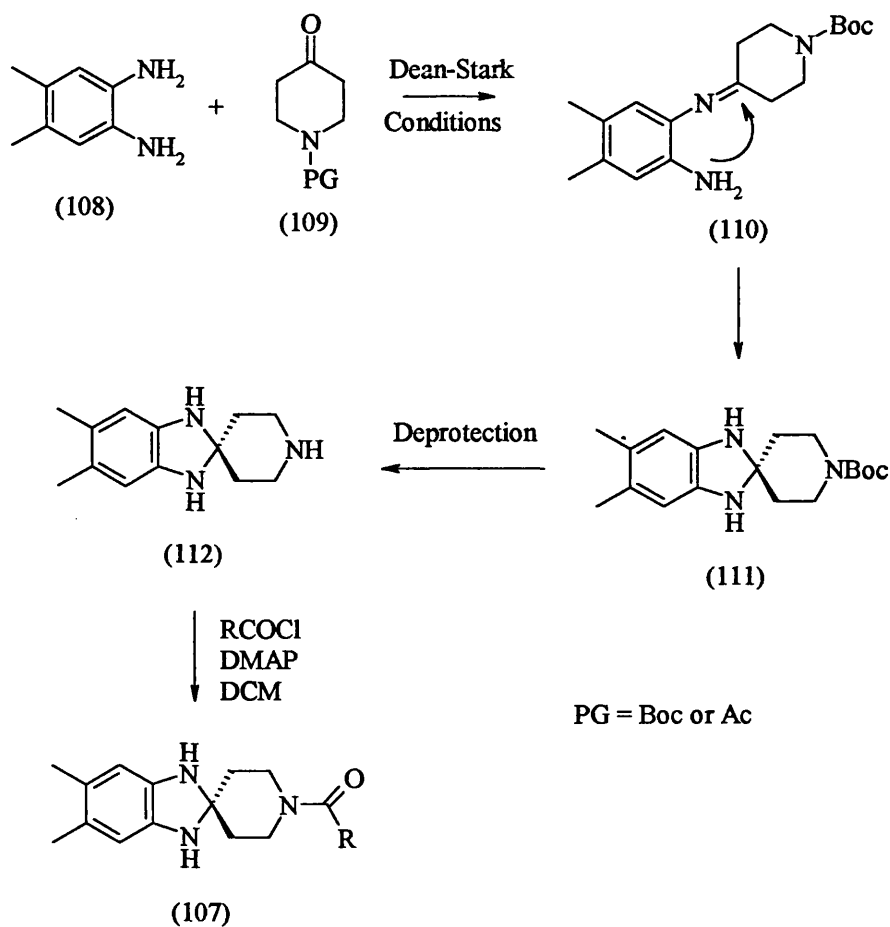

Scheme (53)

In practice, commercially available *N*-Boc protected 4-piperidone (109) was allowed to react under Dean-Stark conditions with 4,5-dimethyl-1,2-diaminebenzene (108), formed previously by the hydrogenation of 2-nitro-4,5-dimethylaniline.

After 4 h TLC analysis of the reaction mixture showed the formation of a new compound, which was presumed to be the imine (110). This was prompted by the electronic spectrum, which revealed a band at  $\lambda_{\text{max}} = 285 \text{ nm}$ . When sodium borohydride was added to the UV sample, this band disappeared. Unfortunately this seemed to be the end of the reaction since the electronic spectrum of the reaction mixture at the end of a 24 h period at reflux had not changed from that after 4 h.

In light of this result we repeated the experiment with a catalytic amount of 4-toluenesulfonic acid added to promote cyclisation of the presumed imine. The end result was the same however, and further attempts to induce cyclisation by increasing the amount of acid also proved unsuccessful.

In 1984, Suschitzky and co-workers<sup>95</sup> reported the preparation of a closely related compound (114, R=H) by heating 1,2-phenylenediamine (108, R=H) with cyclohexanone in water at reflux for a period of only 10 mins.

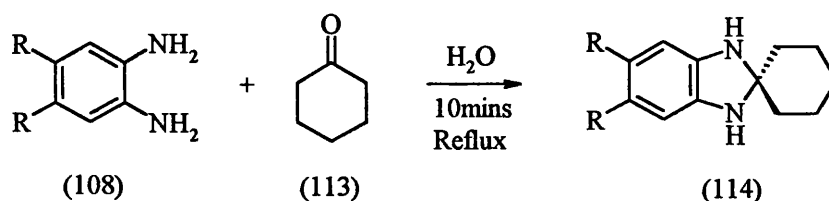

Scheme (54)

We were pleased to discover that when this procedure was repeated using 4,5-dimethylphenylenediamine (108, R=Me) the corresponding benzimidazolidine (114, R=Me) was produced in 66 % yield.



The successful synthesis prompted us to examine the possibility of using the *N*-protected piperidone (115) and indeed this led to our target compound (111), but in only 26% yield.

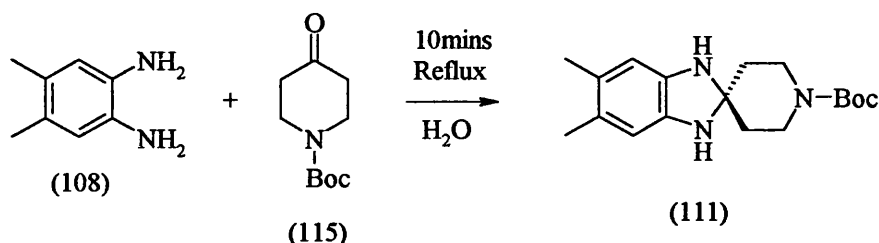

Scheme (55)

Once isolated, deprotection of the nitrogen atom of the product was attempted. Treating the benzimidazolidine (111) with a solution of TFA:DCM (1:1) however, proved unrewarding. TLC analysis of the reaction mixture revealed the presence of a multi component mixture. This was not surprising as it is known that imidazolidines readily hydrolyse in the presence of acids to afford the corresponding aldehyde and diamine of synthesis. However, such a functionality is reported to be more stable in the presence of alkali<sup>94</sup>.

In light of this, we decided to repeat the ring-forming reaction using *N*-acetylpiperidone (116), and when *N*-acetylpiperidone (116) was heated with 4,5-dimethylphenylenediamine (108) under the same conditions as that adopted previously, the desired compound (117) was isolated in 78 % yield.

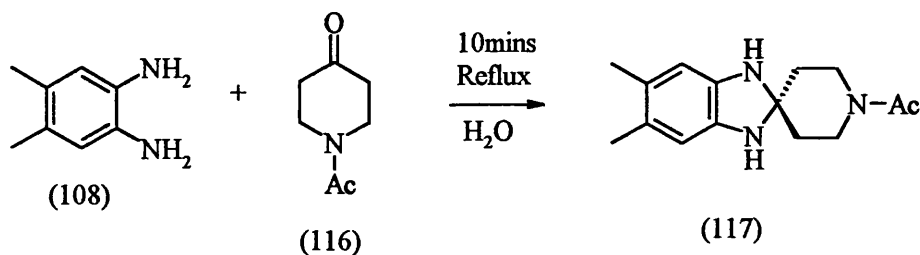

Scheme (56)

The next step was the removal of the acetyl group. This was attempted by stirring the parent compound (117) in the presence of aqueous 10% potassium carbonate for 2 h. However, TLC analysis of the reaction mixture revealed many compounds with similar R<sub>f</sub> values; these could not be separated by column chromatography on silica.

It was only after we had the *N*-acetyl and *N*-Boc protected benzimidazolidines in our possession for a few days that we realised they were unstable and we consider that they revert back initially to the corresponding 2-iminoanilines. From here these products decompose further, probably through hydrolysis in moist air, to the phenylenediamine and the piperidone.

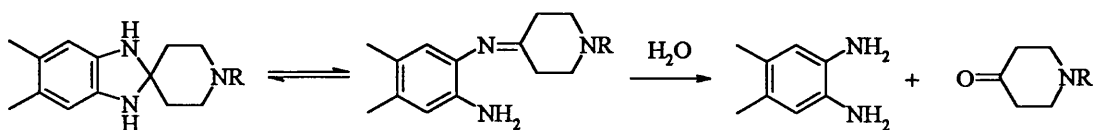

Scheme (57)

This instability is not acceptable in a potential drug and further work in the area was stopped, especially as we discovered that chemists at Astra Sweden had worked on related benzimidazolines and discovered them to be unsatisfactory in their test regimes.

We next turned to analogues where no spiro centre exists and we selected the “open” chain 1,2-phenylenediamines (122) where, as before, R could be groups of variable lipophilicity. The initial synthetic strategy employed is shown [Scheme (58)].

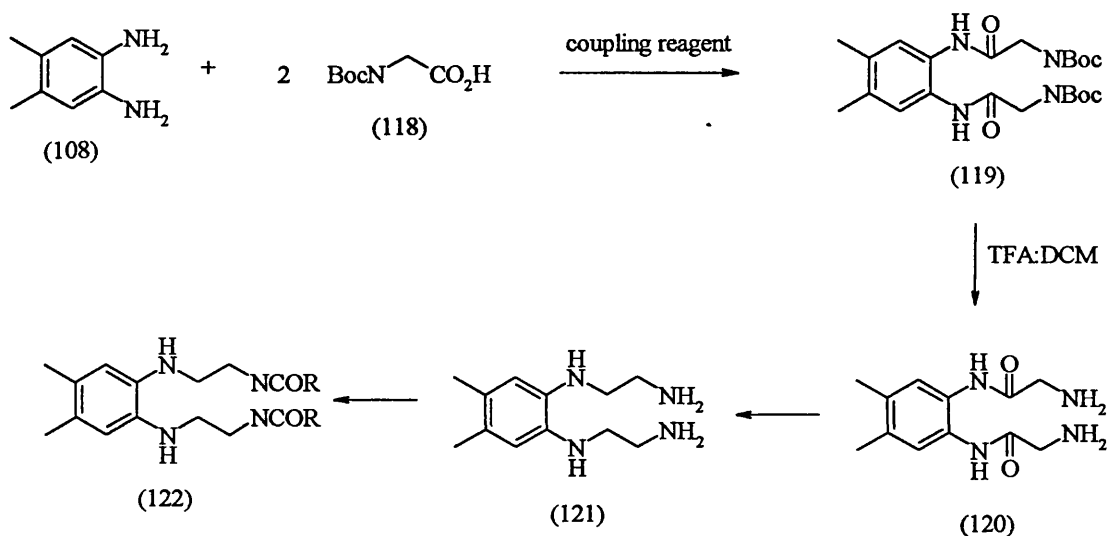

Scheme (58)

The first step involved treating the 1,2-phenylenediamine (108) with *N*-Boc glycine (118) in the presence of DCC. Although this coupling proved successful the maximum yield was only 22 %.

It is well known that a major side reaction encountered with carbodiimides is O-*N*-acyl migration as shown in [Scheme (59)] and we considered that this may well account for the low productivity in our reaction.

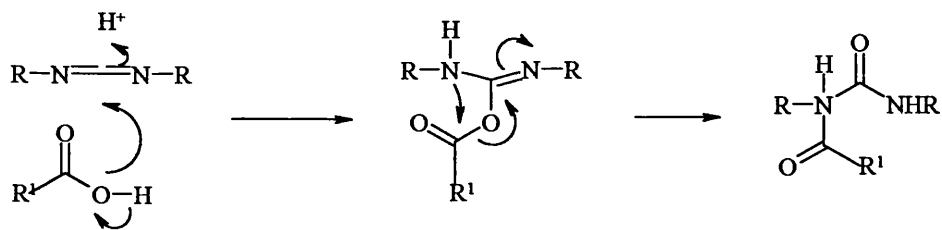

Scheme (59)

To overcome this problem, a number of different reagent systems have been developed. One such is the use of 1-hydroxybenzotriazole (HOBt), which in the presence of carbodiimides promotes only *N*-acylation. The role of the triazole is to form an O-acyl derivative by an exchange with the acylated diimine and it is this which reacts with the amine.

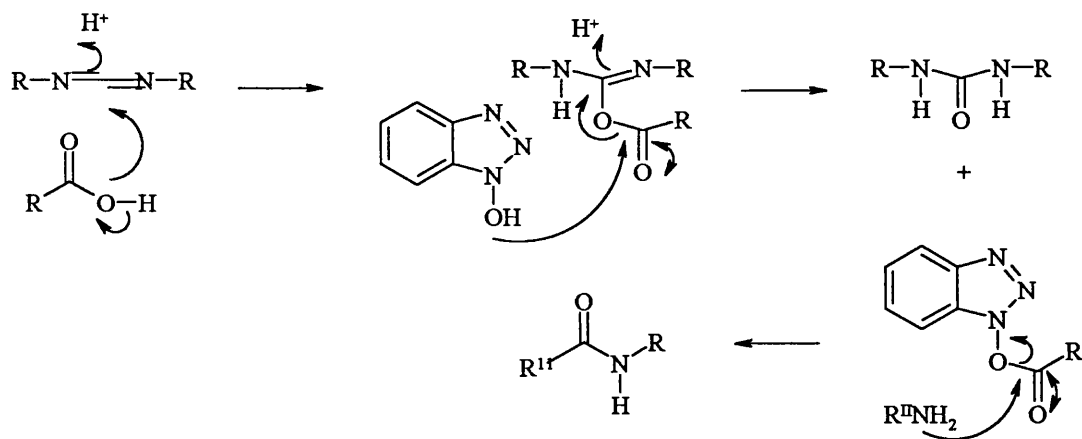

Scheme (60)

When this reagent combination was used with *N*-Boc glycine (118) and the dimethylphenylenediamine (108) we obtained the desired product (119) in 30 % yield. However, it was highly contaminated by dicyclohexylurea which proved very difficult to remove. In view of this, we decided to explore another coupling reagent. Initially 1-ethyl-3-(3-dimethylamino)propylcarbodiimide (EDC)<sup>96</sup> was chosen. This reagent has the advantage that all the coupling reagent by-products can be washed out easily using an aqueous or acid workup.

Reacting the phenylenediamine (108) and *N*-Boc glycine (118) in the presence of EDC in DCM resulted in a substantial increase in the yield of the product that was formed from 30 to 73%.

Having obtained the Boc protected diamide (119) in good yield, *N*-deprotection was performed by treating it with a solution of TFA:DCM (1:1) for 2 h. This afforded the deprotected diamide (120) in 44 % yield).

The next step in the synthesis involved the reduction of the diamide (120) to the tetraamine. An initial attempt using excess diborane in THF at reflux proved unrewarding. Even after 20 h, only starting material was isolated.

Next, lithium aluminium hydride in refluxing THF was employed but this gave a multi-component mixture that proved impossible to separate by column chromatography.

Turning to the literature we noted that Ito *et al.*<sup>97</sup> had reported success when reducing tertiary amides to the corresponding amines with hydrosilanes in the presence of rhodium complexes. Although the actual mechanism is still under investigation, it is thought that the catalytic cycle involves oxidative addition of hydrosilane to a Rh(I) complex [Scheme (61)]. In the process the Rh(I) complex is converted into a hydrido(silyl)rhodium(III) species, (124), which undergoes insertion of the amide substrate. The carbon of the amide is bonded to the Rh metal and silicon migrates to oxygen. Rapid intermolecular hydride transfer leads to reductive cleavage of the O-Si bond and finally the reagent is reformed as an intramolecular hydride shift competes the reduction of the amine.

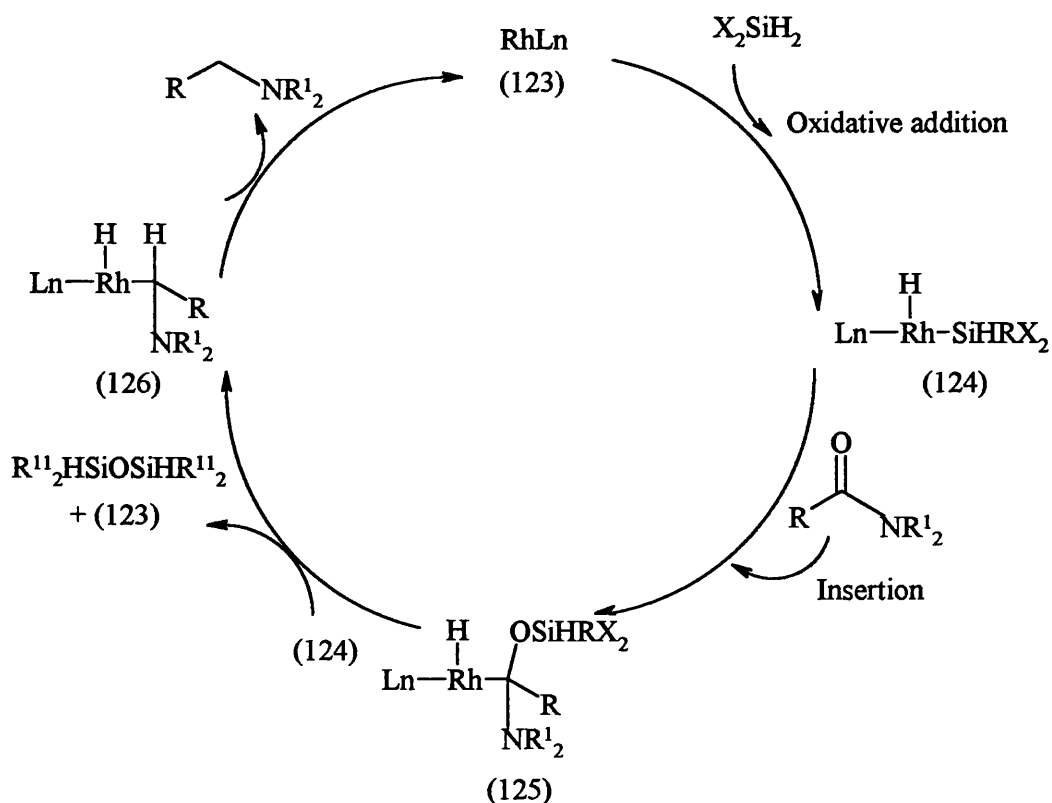

Scheme (61)

In our hands however, treatment of diamide (120) with 0.1 mol%  $\text{RhH}(\text{CO})(\text{PPh}_3)_3$  in THF in the presence of  $\text{Ph}_2\text{SiH}_2$  at room temperature led to the disappearance of starting amide, but we could not isolate the product. This probably reflects the highly soluble nature of the very basic tetraamine. Indeed, on reflection we began to realise how difficult the obtention of such a compound might be and that a more realistic aim might be to form the required diamides by reductive amination using a precursor in which the side chain amino groups already contained the amide units in place. Initially we considered the synthesis of the lauroyl derivative (127), but first it was necessary to prepare the intermediate amidoaldehyde (128). The three step synthesis is outlined below:

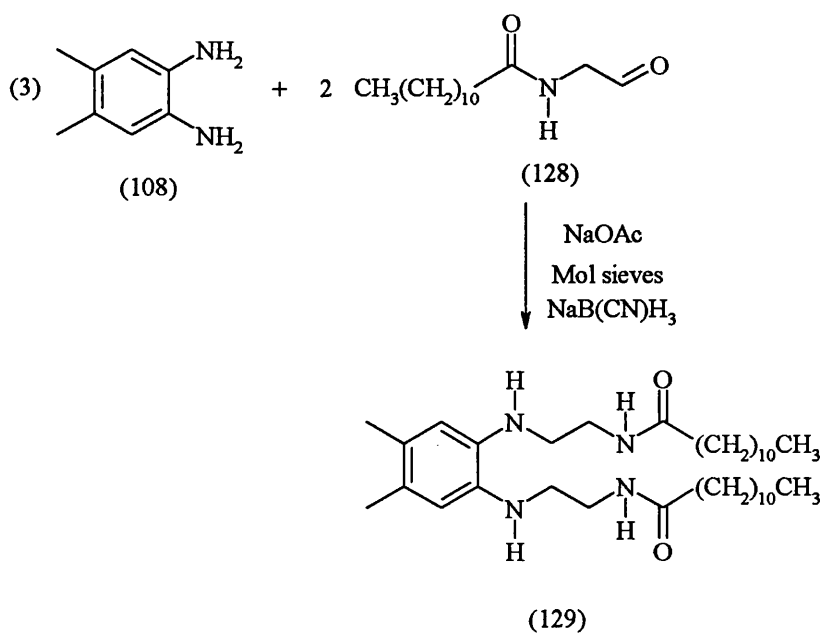
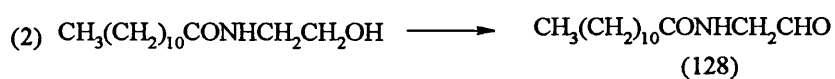
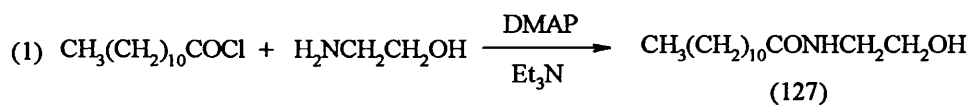

Scheme (62)

Step one involved reacting ethanolamine with lauroyl chloride in the presence of DMAP and triethylamine in DCM. This was indeed successful, affording the hydroxyamide (127) in 70% yield, which we next attempted to oxidise to the corresponding aldehyde (128). This was achieved by treatment of the amido alcohol (127) with pyridinium chlorochromate (PCC). After 1 h IR spectroscopy of the reaction mixture revealed the formation of the desired aldehyde as indicated from an extra absorption peak at  $\nu_{\max}$  1740  $\text{cm}^{-1}$ . It soon became apparent however, that if the reaction mixture was left for a longer period of time e.g. 5 h, the formation of the corresponding acid took place as evidenced by the appearance of a new broad signal centred at  $\nu_{\max} = 3320 \text{ cm}^{-1}$ . It should be noted that an alternative approach, treating the alcohol (127) with a solution of oxalyl chloride and DMSO, also resulted in the formation of the corresponding acid, this time as the sole product.

As a solution of the aldehyde rapidly oxidised in air it was essential that it was used directly without purification in the reductive amination step. Reacting two equivalents of aldehyde (128) with the diamine (108) in the presence of freshly fused sodium acetate, freshly activated molecular sieves and sodium cyanoborohydride afforded a dark oil. This contained several components, which ran closely together on a TLC plate.

An alternative approach would be to carry out the alkylation of the phenylenediamine with the alkyl bromide formed from the amidoalcohol (127).



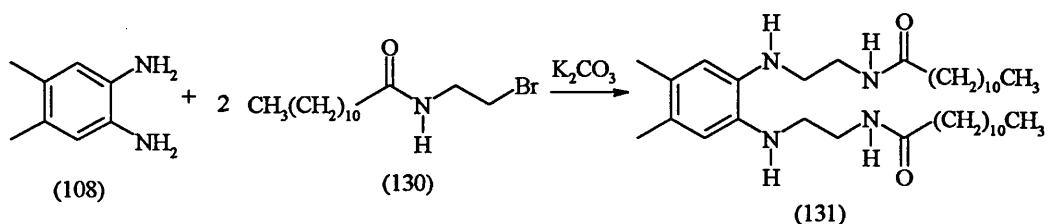

Scheme (63)

Treating alcohol (127) with freshly distilled phosphorus tribromide afforded a yellow solution, which was rapidly quenched on addition of ice water giving only returned amidoalcohol (127). It now seems likely that hydrolysis of the bromo derivative occurs extremely rapidly and had we time to pursue this project further it would have been necessary to use it in the crude form without isolation or treatment with water.

The unsatisfactory end of this work coincided with disappointment in the testing programme. After £20 million had been spent upon developing antioxidants of the indenoindole and indoline types Astra and Eirex decided to pull out of further work in the area.

It was not a question of lack of antioxidant effect, it was a general feeling of the industry that antioxidants in general, might not deliver the protection they once seemed to offer. Vitamin E itself as a supplement to human diet had been shown to act as a promoter as well as an inhibitor of radical processes. Probuocol the lead compound in the area had to be withdrawn several years before and unfortunately Astra's own animal studies failed to show a major reduction of plaque development in the Watanbe rabbit. These conclusions and considerations brought the whole synthetic programme to an end.

## 6.0 Experimental

Chemicals, solvents and reagents were purified and dried, where appropriate, before use by standard methods. 'Petrol' refers to Petroleum ether boiling in the range 40-60°C.

Column chromatography was performed using Amicon Matrix 60Å silica gel under medium pressure using a small hand bellow. Thin layer chromatography (tlc) was performed on Whatman pre-coated glass plates. Visualisation was achieved by illumination under a short wavelength (254nm) ultra violet light where possible.

Melting points were determined on Electrothermal MK III apparatus and are uncorrected. Mass spectra were recorded using a Finnigan MAT 8340 magnetic mass spectrometer. Infa-red (IR) spectra were measured as liquid films and recorded in the range 4000-600cm<sup>-1</sup> using a Perkin Elmer 1605 FT-IR spectrometer.

<sup>1</sup>H and <sup>13</sup>C nuclear magnetic resonance spectra were recorded on a Jeol GX270 (270MHz) or Jeol GX400 (400MHz) spectrometer. For the <sup>13</sup>C, the operating frequency was 67.8mHz, using 90° and 135° DEPT pulse sequences to aid multiplicity determinations. Samples were prepared in solutions of deuterated chloroform or DMSO. δ values are expressed as parts per million downfield from tetramethylsilane as internal standard and coupling constants (*J*) in Hz.

**Trans-2,3,4,4a,5,6,11,11b-Octahydro-8-isopropyl-1H-benzo[a]carbazole (14)**

**and 1,2,3,4,4a,5,6,7-Octahydro-11-isopropylbenzo[d]carbazole (12)<sup>17</sup>**

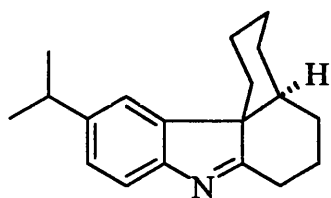

(12)

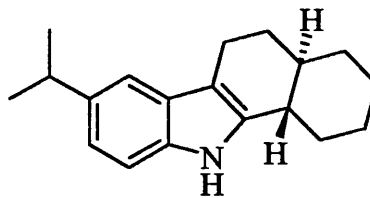

(14)

4-Isopropylphenylhydrazine hydrochloride (10g, 53mmol), 1 decalone (8g, 8.2cm<sup>3</sup>, 53mmol), freshly fused sodium acetate (8.6g, 106.7mmol) and glacial acetic acid (75cm<sup>3</sup>) were heated in an oil bath firstly at 60°C for 30 mins and then at 110°C for 2 h. The solvent was removed and residue partitioned between ethyl acetate and water. The organic layer was collected, washed with brine 20cm<sup>3</sup> (x2) and then saturated sodium hydrogen carbonate 20cm<sup>3</sup> (x2), dried and evaporated. The residue was triturated with light petrol and the solid which formed was collected and washed sparingly with light petrol, until the filtrate was almost colourless. The colourless powder (7.0g) that remained consisted of a 2:1 mixture of indolenine (12) and indole (14). This mixture could be separated with difficulty by repeated crystallisation. The washings and filtrate were combined and evaporated to afford a brown oil (6.2g) which was chromatographed on silica gel, eluting with 4% ethyl acetate in petrol to afford the indole (14) as a pale yellow unstable oil (1.5g, 11%),  $\nu_{\max}/\text{cm}^{-1}$  3406cm<sup>-1</sup>,  $\delta_{\text{H}}$  (CDCl<sub>3</sub>); 1.2 (2H, m), 1.3 (6H, d,  $J= 6.7$ , <sup>i</sup>Pr), 1.3-2.2 (11H, m), 2.6-2.9 (1H, m), 3.0 (1H, sept,  $J= 6.7$ , <sup>i</sup>Pr-CH), 7.0 (1H, dd,  $J= 8.2$ , 1.7, Ar-H), 7.2 (1H, d,  $J= 8.2$ , Ar-H), 7.3 (1H, d,  $J= 1.7$ , Ar-H)  $\delta_{\text{C}}$  (CDCl<sub>3</sub>); 21.2 (2H),

24.8 (6H), 26.3 (2H), 26.4 (2H), 30.1 (2H), 30.9 (2H), 33.2 (2H), 34.3, 40.7, 41.8, 109.3, 110.3, 114.8, 120.0, 127.8, 134.3, 137.7, 140.0.  $m/z$  (EI) % 267.2 (30,  $M^+$ ).

Further elution with 4% ethyl acetate in petrol gave more of the indole (14) contaminated with another component and elution with 20% ethyl acetate in petrol then yielded the indolenine (12) as an oil (4.2g, 30%),  $\nu_{\max}/\text{cm}^{-1}$  1610 $\text{cm}^{-1}$  (C=N),  $\delta_{\text{H}}$  ( $\text{CDCl}_3$ ); 1.0 (1H, brd,  $J=11.5$ ), 1.3 (6H, d,  $J=7.0$ ,  $^i\text{Pr}$ ), 1.4-1.8 (7H, m), 2.0-2.2 (5H, m), 2.6 (1H, ddd,  $J=13.0, 13.0, 5.5$ ), 2.80 (1H, dddd,  $J=13.6, 5.5, 2.5, 2.5$ ), 3.0 (1H, sept,  $J=7.0$ ,  $^i\text{PrCH}$ ), 7.2(1H, dd,  $J=7.9, 1.8$ , Ar-H), 7.5 (1H, d,  $J=7.9$ , Ar-H), 7.6 (1H, d,  $J=1.5$ , Ar-H),  $\delta_{\text{C}}$  ( $\text{CDCl}_3$ ): 19.9 (2H), 21.6 (2H), 24.5 (6H), 26.4 (2H), 27.1 (2H), 27.4 (2H), 28.3 (2H), 29.4 (2H), 34.3, 41.1, 57.5, 119.8, 123.0, 125.3, 144.8, 145.8, 152.6, 189.3.  $m/z$  (EI) % 267.2 (95,  $M^+$ ), 252.2 (100,  $M^+ - \text{Me}$ ).

**1,2,3,4,4a,5,6,7-Octahydro-8-tert-butoxycarbonyl-11-(isopropyl)benzo[d]carbazole (20)**

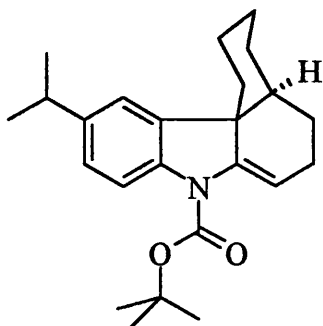

A solution of the indolenine (22) (0.4g, 0.8mmol), di-*tert*-butyldicarbonate (0.4g, 1.6mmol) and freshly fused sodium acetate (0.1g, 1.6mmol) were dissolved in THF

and stirred under nitrogen for a few mins. The reaction was then left to stir at 60-70°C for 5 weeks over which time a further 6 equivalents of di-*tert*-butyldicarbonate were added. On completion the tetrahydrofuran was removed *in vacuo* and the resultant viscous brown oil was taken up in ethyl acetate (40cm<sup>3</sup>) and washed with water 10 cm<sup>3</sup> (x2) and brine 10cm<sup>3</sup> (x2). The organic phases were combined, dried and evaporated to afford a brown oil, which was chromatographed on silica gel, eluting with 4% ethyl acetate in petrol to afford the title compound as a viscous colourless oil (0.13g, 36%),  $\nu_{\max}\text{cm}^{-1}$  1713cm<sup>-1</sup>,  $\delta_{\text{H}}$  (CDCl<sub>3</sub>); 1.0 (1H, m), 1.3 (6H, d,  $J=7.0$ , <sup>i</sup>Pr), 1.5 (9H, s, <sup>t</sup>Bu), 1.5-2.4 (12H, m), 2.9 (1H, hept,  $J=7.0$ , <sup>i</sup>PrCH), 5.9 (1H, bs, 7-H), 7.1 (1H, m, Ar-H), 7.4 (1H, d,  $J=1.6$ , Ar-H), 7.6 (1H, d,  $J=8.2$ , Ar-H),  $\delta_{\text{C}}$  (CDCl<sub>3</sub>); 20.2 (2H), 20.8 (2H), 23.6 (2H), 24.4 (2H), 27.3 (6H), 27.8 (9H), 28.9 (2), 34.0 (2H), 33.8, 34.7, 45.3, 108.3, 115.1, 123.0, 124.5, 138.5, 139.2, 142.5, 145.8, 146.7, 151.7, 152.1.  $m/z$  (FAB) % 367.3 ( $M^{\dagger}+1$ , 40).

Found :  $m/z$  (FAB) 367.251663, C<sub>24</sub>H<sub>33</sub>NO<sub>2</sub>, ( $M^{\dagger}+1$ ) requires : 367.251130.

#### **6-Isopropyl 1,2,3,4-tetrahydro-4a-methyl-carbazole (22)**

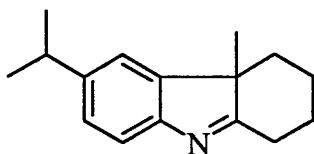

The 4-isopropylphenylhydrazine hydrochloride (5.0g, 33mmol), 2-methyl cyclohexanone (3.7g, 4cm<sup>3</sup>, 33mmol), freshly fused sodium acetate (4.6g, 66mmol) and glacial acetic acid (40cm<sup>3</sup>) were heated in an oil bath firstly at 60°C for 30

mins and then at 110°C for 2 h. The solvent was removed and residue partitioned between ethyl acetate and water. The organic layer was collected, washed with brine 10cm<sup>3</sup> (x2) and then with saturated sodium hydrogen carbonate 10cm<sup>3</sup> (x2), then dried with magnesium sulfate. The organic layers were combined and evaporated to afford a brown oil which was chromatographed on silica gel, eluting with 30% ethyl acetate in petrol to afford the title compound as a pale yellow oil (5.1g, 68%),  $\nu_{\max}/\text{cm}^{-1}$  1582.6cm<sup>-1</sup> (C=N),  $\delta_{\text{H}}$  (CDCl<sub>3</sub>); 1.3 (6H, d,  $J=7.0$ , <sup>i</sup>Pr), 1.3 (3H, s, Me), 2.6 (1H, m), 2.9 (1H, m), 3.0 (1H, hept,  $J=7.0$ , <sup>i</sup>PrCH), 7.2 (1H, d,  $J=1.8$ ), 7.2 (1H, dd,  $J=7.9$ , 1.8), 7.5 (1H, d,  $J=7.9$ ),  $\delta_{\text{C}}$  (CDCl<sub>3</sub>); 19.7 (3H), 21.2 (2H), 24.2 (6H), 28.9 (2H), 29.4 (2H), 34.0, 38.5 (2H), 53.5, 119.2, 119.5, 125.3, 145.7, 146.6, 151.9, 189.4.  $m/z$  (EI) % 227.2 (40, M<sup>+</sup>).

Found :  $m/z$  (EI) 227.167297, C<sub>16</sub>H<sub>21</sub>N (M<sup>+</sup>) requires : 227.167400.

**Synthesis of 1,2,3,4 tetrahydro-6-isopropyl-9-*tert*-butoxycarbonyl-4a-methyl-carbazole (23)**

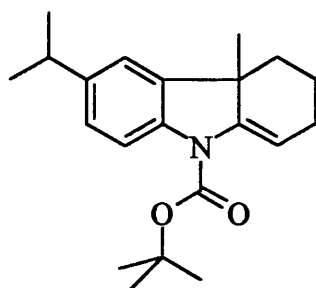

A solution of the indolenine (22) (0.5g, 2.2mmol), di-*tert*-butyldicarbonate (0.48g, 2.2mmol) and freshly fused sodium acetate (0.15g, 2.2mmol) were dissolved in THF and stirred under nitrogen for a few mins. The reaction was then left to stir at

60-70°C for 3 days over which time a further equivalent of di-*tert*-butyldicarbonate was added. On completion of the reaction the tetrahydrofuran was removed *in vacuo* and the resultant viscous brown oil was taken up in ethyl acetate (40cm<sup>3</sup>) and washed with water 15cm<sup>3</sup> (x2) and then brine 15cm<sup>3</sup> (x2). The organic phases were combined dried and evaporated to afford a brown oil, which was chromatographed on silica gel, eluting with 4% ethyl acetate in petrol. This afforded the title compound as a viscous colourless oil (0.37g, 51%)  $\nu_{\max}/\text{cm}^{-1}$  1713cm<sup>-1</sup> (C=O),  $\delta_{\text{H}}$  (CDCl<sub>3</sub>); 1.2 (6H, d,  $J=7.0$ , <sup>i</sup>Pr), 1.3 (3H, s, Me), 1.6 (9H, s, <sup>t</sup>Bu), 1.6-2.3 (6H, m), 2.9 (1H, hept,  $J=7.0$ , <sup>i</sup>PrCH), 5.9 (1H, bs, 7-H), 7.0 (1H, d,  $J=2.0$ ), 7.03 (1H, dd,  $J=1.7, 1.8$ ), 7.6 (1H, d,  $J=8.2$ ),  $\delta_{\text{C}}$  (CDCl<sub>3</sub>); 17.5 (2H), 23.0 (2H), 24.2 (3H), 24.2 (3H), 27.7 (3H), 23.4 (9H), 31.4 (2H), 33.8, 41.6, 81.5, 107.2, 115.0, 119.4, 124.9, 138.7, 139.6, 143.8, 145.2, 151.8,  $m/z$  (FAB) % 327.2 (50, M<sup>+</sup>+1).

Found :  $m/z$  (EI) 327.220276, C<sub>21</sub>H<sub>29</sub>NO<sub>2</sub> (M<sup>+</sup>+1) requires : 327.219829 .

### **1,2,3,4,9,9a-Hexahydro-6-isopropyl-4a-methylcarbazole (25)**

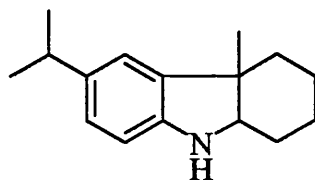

Indolenine (22) (1.5g, 6.6mmol) was placed in tetrahydrofuran (10cm<sup>3</sup>), then sodium borohydride (0.25g, 6.6mmol) was added portionwise. The reaction mixture was then left to stir overnight. On completion of the reaction a solution of

1M sodium hydroxide (5cm<sup>3</sup>) was added. The tetrahydrofuran was removed *in vacuo* and the resultant viscous brown oil was taken up in ethyl acetate (40cm<sup>3</sup>) and washed with water 5cm<sup>3</sup> (x2) and brine 5cm<sup>3</sup> (x2). The organic phases were combined, dried and evaporated to afford a brown oil which was chromatographed on silica gel, eluting with 10% ethyl acetate in petrol to afford the title compound as a pale yellow oil (3.0g, 40%),  $\delta_{\text{H}}$  (CDCl<sub>3</sub>); 1.2 (6H, d,  $J=6.8$ , <sup>i</sup>Pr), 1.3 (3H, s, Me), 1.3-1.7 (8H, m), 2.8 (1H, hept,  $J=6.8$ , <sup>i</sup>PrCH), 3.4 (1H, t,  $J=4.3$ ), 6.6 (1H, d,  $J=8.3$ , Ar-H), 6.87 (1H, s, Ar-H), 6.9 (1H, d,  $J=2.0$ , Ar-H),  $\delta_{\text{C}}$  (CDCl<sub>3</sub>); 21.1 (2H), 21.4 (2H), 24.2 (3H), 27.4 (2H), 35.0 (3H), 35.3 (3H), 42.7 (2H), 60.3, 66.0, 109.8, 119.6, 124.5, 139.5, 139.6, 147.3.  $m/z$  (EI) % 229.2 (60, M<sup>+</sup>).

Found :  $m/z$  (EI) 229.183064 C<sub>16</sub>H<sub>23</sub>N (M<sup>+</sup>) requires :. 229.183050.

**Preparation of *N*-Boc -9a-hydroxy-6-isopropyl-4a-methyl-1-bromo-1,2,3,4,4a,9-hexahydro[9aH]carbazole (30)**

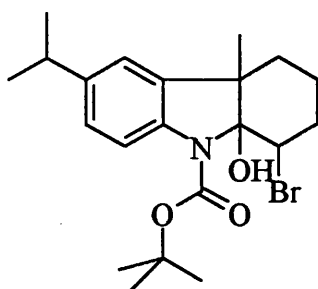

The *tert*-butoxycarbonyl protected carbazole (23) (0.17g, 0.5mmol) was placed in DCM (10cm<sup>3</sup>). *N*-Bromosuccinimide (0.1g, 0.5mmol) was added in one portion and catalytic hydrogen peroxide was added dropwise (0.1cm<sup>3</sup>, 27% solution in water). The reaction was then left to stir at room temperature for 16 h. The



reaction mixture was quenched with water, extracted with ethyl acetate and dried *in vacuo*. Column chromatography on silica gel, eluting with 10% ethyl acetate in petrol yielded the title compound as an oil (0.01g, 4.7%),  $\delta_{\text{H}}$  ( $\text{CDCl}_3$ ); 0.9 (1H, m), 1.2 (6H, d,  $J=7.1$   $^i\text{Pr}$ ), 1.3 (3H, s, Me), (1.6-1.7 (1H, m), 1.7-2.2 (4H, m), 2.9 (1H, hept,  $J=7.1$ ,  $^i\text{PrCH}$ ), 4.2 (1H, t,  $J=4.8$ ,  $\text{CHBr}$ ), 7.1 (1H, dd,  $J=7.9$ , 1.8, Ar-H), 7.2 (1H, d,  $J=1.8$ , Ar-H), 7.4 (1H, brs, Ar-H),  $\delta_{\text{C}}$  ( $\text{CDCl}_3$ ); 23.6 (2H), 24.6 (6H), 27.6 (3H), 28.9 (9H), 28.9 (2H), 30.2 (2H), 34.3, 50.8, 82.6, 117.4, 119.5, 125.6, 126.5, 136.6, 144.8.  $m/z$  (FAB) 425.1/427.2 (40, 40,  $\text{M}^++1$ )  
Found :  $m/z$  (FAB) 425.15950/427.14730  $\text{C}_{21}\text{H}_{31}\text{NO}_3\text{Br}$  ( $\text{M}^++1$ ) requires : 425.14890/427.14680.

### **8-Bromo-1,2,3,4-tetrahydro-6-isopropyl-4a-methylcarbazole (33)**

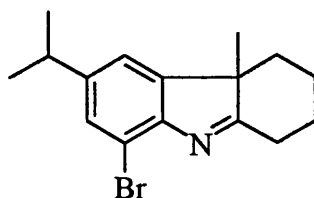

#### **Method 1**

To a solution of the indolenine (22) (0.2g, 0.9mmol) in DCM ( $10\text{cm}^3$ ) was added *N*-bromosuccinimide (0.16g, 0.9mmol) and a catalytic amount of hydrogen peroxide ( $0.1\text{cm}^3$ , 27.5% solution in water). The reaction mixture was then left to stir for a further 16 h before being poured into water. The organic layer was separated and the residue extracted with DCM  $5\text{cm}^3$  (x2). The combined organic layer and extracts were then dried and evaporated to afford a brown oil which was chromatographed on silica gel, eluting with 30% ethyl acetate in petrol. This gave

the title compound as a pale yellow oil (0.08g, 29%),  $\delta_{\text{H}}$  ( $\text{CDCl}_3$ ); 1.3 (6H, d,  $J=7.0$ ,  $^i\text{Pr}$ ), 1.3 (3H, s, Me), 1.4-1.5 (2H, m), 1.7-1.8 (2H, m), 2.2-2.3 (2H, m), 2.6 (1H, m), 2.9 (1H, m), 2.9 (1H, hept,  $J=7.0$ ,  $^i\text{PrCH}$ ), 7.1 (1H, d,  $J=1.5$ , Ar-H), 7.3 (1H, d,  $J=1.5$ , Ar-H),  $\delta_{\text{C}}$  ( $\text{CDCl}_3$ ); 19.8 (3H), 21.2 (2H), 24.1 (6H), 28.8 (2H), 29.7 (2H), 33.9, 38.6 (2H), 55.4, 113.4, 118.5, 128.6, 147.7, 148.4, 150.4, 190.8.  $m/z$  (EI) % 305.0/307.1 (30, 30,  $\text{M}^+$ )

Found :  $m/z$  (EI) 305.078003/307.07560  $\text{C}_{16}\text{H}_{19}\text{NBr}$  ( $\text{M}^+$ ) requires : 305.077911/307.07601.

## Method 2

To a solution of the indolenine (22) (1.0g, 4.4mmol) in dry chloroform ( $10\text{cm}^3$ ) was added aluminium trichloride (0.1g, 0.7mmol). The reaction mixture was left to stir at  $0^\circ\text{C}$  for 15 mins before the addition of bromine (0.7g,  $0.23\text{cm}^3$ , 4.4mmol). The solution was left to stir for 2 h at  $0^\circ\text{C}$  and for a further 2 h at room temperature. The solution was then washed with sodium hydrogen sulphate  $5\text{cm}^3$  (x2). The organic layer was removed and the residue was extracted with DCM  $5\text{cm}^3$  (x2). The organics were combined and evaporated to afford a brown oil which was chromatographed on silica gel, eluting with 10% ethyl acetate in petrol. This gave two products, which could not be separated.

**Attempted ortho-lithiation of 8-Bromo-1,2,3,4-tetrahydro-6-isopropyl-4a-methylcarbazole (34)**

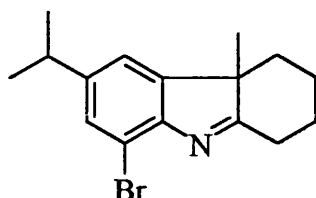

Bromoindolenine (33) (0.2g, 0.7mmol) was placed in ultra dry THF (10 cm<sup>3</sup>). TMEDA (0.2cm<sup>3</sup>, 1.4mmol) was then added. After a few mins *n*-butyllithium (0.4cm<sup>3</sup>, 2.5M in hexanes) was added dropwise at -78°C. The solution was left to stir at -78°C for 2 h, before quenching with excess allyl chloride (1cm<sup>3</sup>, 7.0mmol). The tetrahydrofuran was removed *in vacuo* and the resultant viscous yellow oil was taken up in ethyl acetate (20cm<sup>3</sup>) and washed with water 5cm<sup>3</sup> (x2) and brine 5cm<sup>3</sup> (x2). The organic phases were combined, dried and evaporated to afford an oil which was chromatographed on silica gel, eluting with 20% ethyl acetate in petrol to afford the debrominated compound (22) as a pale yellow oil in quantitative yield,  $\delta_{\text{H}}$  (CDCl<sub>3</sub>); 1.3 (6H, d,  $J=7.0$ , <sup>i</sup>Pr), 1.3 (3H, s, Me), 2.6 (1H, m), 2.9 (1H, m), 3.0 (1H, hept,  $J=7.0$ , <sup>i</sup>PrCH), 7.2 (1H, s), 7.2 (1H, dd,  $J=1.8$ , 6.1), 7.5 (1H, d,  $J=7.9$ ),  $\delta_{\text{C}}$  (CDCl<sub>3</sub>); 19.7 (3H), 21.2 (2H), 24.2 (6H), 28.9 (2H), 29.4 (2H), 34.0, 38.5 (2H), 53.5, 119.2, 119.5, 125.3, 145.7, 146.6, 151.9, 189.4.  $m/z$  (EI) % 227.2 (40, M<sup>+</sup>).

**8-(2-Methoxycarbonylvinyl)-6-isopropyl-1,2,3,4-tetrahydro-4a-methyl-**  
**carbazole (35)**

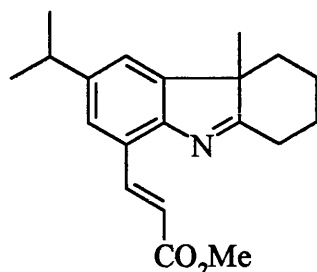

Triphenylphosphine (0.1g, 1.2mmol) and 10% palladium (II) acetate (0.0125g) in freshly distilled toluene (10cm<sup>3</sup>) were stirred for a few mins under nitrogen. Triethylamine (0.1g, 0.1cm<sup>3</sup>, 0.86mmol) was then added dropwise. The bromo compound (33) (0.12g, 0.39mmol) in toluene (5cm<sup>3</sup>) was added before addition of methyl acrylate (0.04g, 0.04cm<sup>3</sup>, 0.39mmol). The reaction mixture was left to stir at 80°C for 2 days. After this time the reaction mixture was poured into water. The organic layer was extracted and the residue washed with DCM 5cm<sup>3</sup> (x2). The organic phases were combined, dried and evaporated to afford a brown oil which was chromatographed on silica gel, eluting with 30% ethyl acetate in petrol. This gave the title compound as a pale yellow oil (0.05g, 41%),  $\delta_{\text{H}}$  (CDCl<sub>3</sub>); 1.27 (6H, m, <sup>i</sup>Pr), 1.74 (4H, m), 2.2 (2H, m), 2.6 (1H, m), 2.9 (1H, hept,  $J=7.0$  (<sup>i</sup>PrCH)), 3.81 (3H, s, OMe), 6.9 (1H, d,  $J=16.1$ ), 7.2 (1H, d,  $J=1.7$ , Ar-H), 7.4 (1H, d,  $J=1.7$ , Ar-H), 8.3 (1H, d,  $J=16.1$ ),  $\delta_{\text{C}}$  (CDCl<sub>3</sub>); 19.9 (3H), 21.3 (2H), 24.2 (6H), 29.0 (2H), 29.8 (2H), 34.1, 38.6 (2H), 51.5 (3H), 53.6, 119.5, 121.1, 124.2, 125.8, 141.4, 146.0, 148.5, 151.7, 167.7, 190.5.  $m/z$  (FAB) % 312.3 (100, M<sup>+</sup>+1)  
Found :  $m/z$  (FAB) 312.196411 C<sub>20</sub>H<sub>26</sub>NO<sub>2</sub> (M<sup>+</sup>+1) requires : 312.196354.

**9-Bromo-1,2,3,4,4a,5,6,7-octahydro-11-isopropylbenzo[d]carbazole (36)**

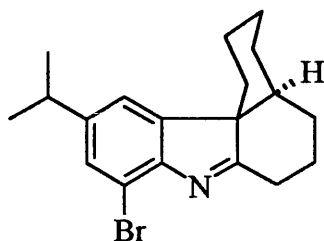

To a solution of the indolenine (12) (1.27g, 4.8mmol) in DCM (20cm<sup>3</sup>) was added *N*-bromosuccinimide (0.85g, 4.8mmol) and a catalytic amount of hydrogen peroxide (0.5cm<sup>3</sup>, 27.5% solution in water). The reaction mixture was then left to stir over the weekend before pouring into water. The organic layer was extracted and the residue washed with DCM 5cm<sup>3</sup> (x2). The organic phases were combined, dried and evaporated to afford a brown oil, which was chromatographed on silica gel, eluting with 30% ethyl acetate in petrol. This gave the title compound as a pale yellow oil; (0.25g, 15%),  $\delta_{\text{H}}$  (CDCl<sub>3</sub>); 1.0 (1H, brd,  $J=12.6$ ), 1.28 (6H, d,  $J=7.0$ , <sup>i</sup>Pr), 1.4-1.8 (7H, m), 2.0-2.2 (5H, m), 2.6 (1H, m), 2.9 (2H, m), 7.4 (1H, d,  $J=1.5$ ), 7.5 (1H, d,  $J=1.5$ );  $\delta_{\text{C}}$  (CDCl<sub>3</sub>); 20.1 (2H), 21.8 (2H), 24.7 (6H), 26.7 (2H), 27.5 (2H), 27.7 (2H), 28.5 (2H), 29.9 (2H), 34.5, 41.6, 59.6, 114.1, 122.3, 128.8, 146.8, 147.5, 150.9, 191.0.  $m/z$  (EI) % 345.1/347.3 (100, 100, M<sup>+</sup>).

Found :  $m/z$  (EI) 345.10921/347.10800 C<sub>19</sub>H<sub>23</sub>NBr (M<sup>+</sup>), requires : 345.10931/347.1073.

**9-(2-Methoxycarbonylvinyl)-1,2,3,4,4a,5,6,7-octahydro-11-**  
**isopropylbenzo[d]carbazole (37)**

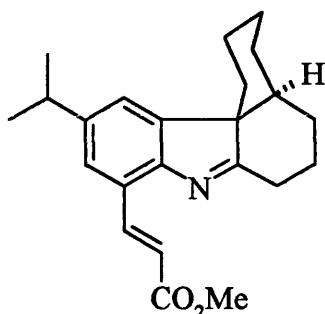

Triphenylphosphine (0.9g, 3.3mmol) and 10% palladium (II) acetate (0.013g) in freshly distilled toluene (10cm<sup>3</sup>) were stirred for a few mins under nitrogen. Triethylamine (0.24g, 0.3cm<sup>3</sup>, 2.4mmol) was then added dropwise. The bromo compound (36) (0.39g, 1.1mmol) dissolved in toluene was added before the addition of methyl acrylate (0.09g, 0.1cm<sup>3</sup>, 1.1mmol). The reaction mixture was left to stir at 80°C for 2 days. It was then quenched with water. The organic phases and washings were combined and evaporated to afford a brown oil, which was chromatographed on silica gel, eluting with 30% ethyl acetate in petrol to afford the title compound as a pale yellow oil (0.05g, 41%),  $\delta_{\text{H}}$  (CDCl<sub>3</sub>); 1.0 (brd, 1H,  $J=11.9$ ), 1.3 (6H, d,  $J=7.0$ ), 1.4-2.2 (12H, m), 2.6 (1H, m), 2.9 (2H, m), 6.9 (1H, d,  $J=16.1$ ), 7.4 (1H, d,  $J=1.7$ ), 7.6 (1H, d,  $J=1.7$ ), 8.3 (1H, d,  $J=16.1$ ),  $\delta_{\text{C}}$  (CDCl<sub>3</sub>); 19.7 (2H), 21.5 (2H), 24.2 (6H), 26.4 (2H), 27.1 (2H), 27.4 (2H), 28.3 (2H), 29.5 (2H), 34.2, 41.1, 51.5 (3H), 57.5, 119.1, 123.5, 124.5, 141.4, 144.9, 146.7, 152.1, 167.7, 190.5.  $m/z$  (EI) % 351.3 (45, M<sup>+</sup>).

Found : (EI) 351.219040 C<sub>23</sub>H<sub>29</sub>NO<sub>2</sub> (M<sup>+</sup>) requires : 351.219829.

**Attempted preparation 9-Bromo-1,2,3,4,4a,5,6,7-octahydro-11-**  
**isopropylbenzo[d]carbazole (38 (39))**

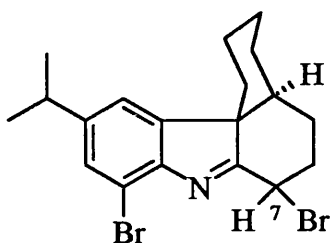

(38)

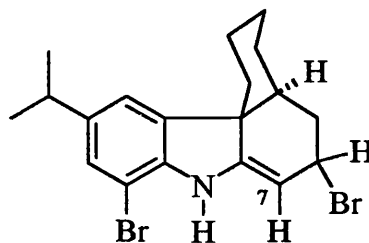

(39)

To a solution of the indolenine (12) (1.27g, 4.8mmol) in DCM (20cm<sup>3</sup>) was added *N*-bromosuccinimide (0.85g, 4.8mmol) and a catalytic amount of hydrogen peroxide (0.5cm<sup>3</sup>, 27.5% solution in water). The reaction mixture was then left to stir over the weekend before pouring into water. The organic layer was extracted and the residue washed with DCM 5cm<sup>3</sup> (x2). The organic phases were combined, dried and evaporated to afford a brown oil, which was chromatographed on silica gel, eluting with 30% ethyl acetate in petrol. This gave a mixture of compounds (38) and (39) which could not be separated by column chromatography  $\delta_{\text{H}}$  (CDCl<sub>3</sub>); 1.2 (2H, brd), 1.3 (14H, m), 1.4-1.8 (16H, m), 2.1-2.2 (2H, m), 2.5 (2H, m), 2.9 (3H, m), 4.4 (1H, m), 4.7 (1H, m), 5.4 (1H, m), 7.4 (2H, d,  $J=1.5$ ), 7.5 (2H, d,  $J=1.5$ ).  $m/z$  (FAB) % 425/427/429 (50:100:50,  $M^+ + 1$ ).

**Preparation of 8-(2-Carboxyvinyl)-6-isopropyl-1,2,3,4-tetrahydro-4a-methyl-carbazole (40)**

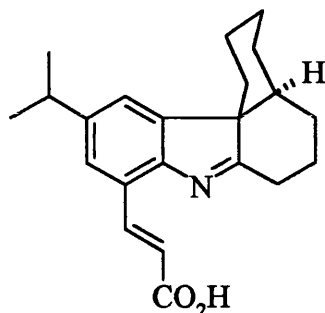

The ester (37) (0.2g, 0.6mmol) was taken up in 2M sodium hydroxide solution (15cm<sup>3</sup>) and left to stir at 60°C for 2 h. The reaction mixture was cooled and filtered through a pad of celite. The mixture was then cooled with ice before addition of concentrated hydrochloric acid. Ethyl acetate was then added and the organic layer was extracted with water 10cm<sup>3</sup> (x2). The organic phases were combined, dried and evaporated to afford the title compound as a pale yellow oil (0.08g, 40%),  $\delta_{\text{H}}$  (CDCl<sub>3</sub>); 1.2 (1H, brd,  $J=11.5$ ), 1.3 (6H, d,  $J=6.8$ ), 1.5-2.1 (12H, m), 2.6 (1H, m), 2.9 (1H, m), 3.6 (1H, m), 6.5 (1H, d,  $J=15.9$ ), 7.5 (1H, s), 7.6 (1H, s), 8.7 (1H, d,  $J=15.9$ ),  $\delta_{\text{C}}$  (CDCl<sub>3</sub>); 19.7 (2H), 21.4 (2H), 24.3 (6H), 26.4 (2H), 27.1 (2H), 27.3 (2H), 28.3 (2H), 28.5 (2H), 34.3, 41.5, 57.4, 120.0, 122.4, 124.6, 126.0, 141.0, 145.5, 146.2, 169.6, 192.5,  $m/z$  (FAB) 338.1 (100, M<sup>+</sup>+1).



**9-Allyl-1,2,3,4,9,9a-Hexahydro-6-isopropyl-4a-methylcarbazole (42)**

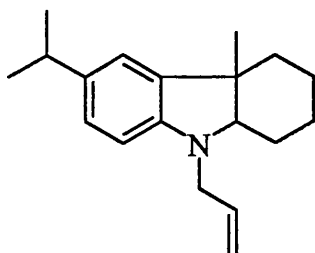

To a stirred solution of sodium hydride (0.07g, 1.5mmol of 60% in oil dispersion) in DMF (20cm<sup>3</sup>) was added at 0°C under nitrogen the carbazole (41) (0.28g, 1.2mmol) in dry DMF. After the addition, the mixture was stirred for a further 10 mins at 0°C. After 10 mins allyl bromide (freshly distilled) (0.15cm<sup>3</sup>, 1.5mmol) was introduced (in dry DMF). The resultant solution was stirred for 15 mins and left to stir at 60°C overnight. After this time, the reaction mixture was cooled to room temperature and poured into cold stirred water (30cm<sup>3</sup>) and extracted with ethyl acetate. The combined organic phases were washed with water 10cm<sup>3</sup> (x2), brine 10cm<sup>3</sup> (x2) and dried over magnesium sulfate. Column chromatography afforded the title compound as a pale yellow oil (0.1g, 31%),  $\delta_{\text{H}}$  (CDCl<sub>3</sub>); 1.2 (6H, d,  $J=6.8$  <sup>i</sup>Pr), 1.3 (3H, s, Me), 1.5-1.6 (8H, m), 1.9 (1H, m), 2.8 (1H, hept,  $J=6.8$ , <sup>i</sup>PrCH), 3.1 (1H, m), 3.5 (1H, m), 3.8 (1H, m), 5.2 (1H, m, CH=CH<sub>2</sub>), 5.3 (1H, m, CH=CH<sub>2</sub>), 5.8 (1H, m, CH=CH<sub>2</sub>), 6.5 (1H, d,  $J=7.9$ , Ar-H), 6.8 (1H, d,  $J=1.8$ , Ar-H), 6.9 (1H, dd,  $J=1.8, 7.9$  Ar-H),  $\delta_{\text{C}}$  (CDCl<sub>3</sub>); 20.8 (2H), 21.7 (2H), 22.0 (3H), 23.5 (2H), 24.4 (6H), 33.6, 36.1 (2H), 41.9, 49.1 (2H), 70.2, 107.7, 116.2 (2H), 119.1, 124.5, 134.8, 138.4, 139.9, 148.8.  $m/z$  (EI) % 269.3 (70, M<sup>+</sup>)

Found :  $m/z$  (EI) 269.213860 C<sub>19</sub>H<sub>27</sub>N (M<sup>+</sup>) requires : 269.214350.

**Attempted preparation of 8-(2-Allyl)-6-isopropyl-1,2,3,4-tetrahydro-4a-methyl-carbazole (43):**

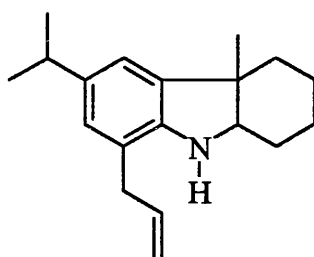

To an efficiently stirred solution of the carbazole (42) (0.44g, 1.6mmol) in dry DCM (50cm<sup>3</sup>) at 20°C, a suspension of freshly ground aluminium trichloride (0.27g, 2.0mmol) in dry DCM (20cm<sup>3</sup>) was added in small portions. The mixture was stirred at room temperature for 20 h under nitrogen before being poured into cold water. The mixture was extracted with DCM. The combined organic layers were washed with water 15cm<sup>3</sup> (x2), brine 15cm<sup>3</sup> (x2) and dried over magnesium sulfate, however, none of the title compound could be isolated.

**Synthesis of 1-acetyl-6<sup>1</sup>-methoxy-4<sup>1</sup>,4<sup>1</sup>,8<sup>1</sup>-trimethylspiro[piperidine-4,2<sup>1</sup>-(1,2,3,4-tetrahydroquinoline)] (50a)**

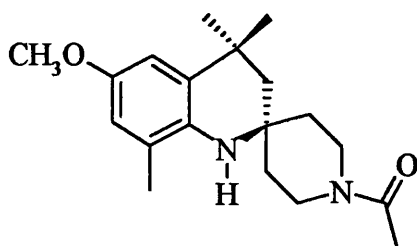

The amine (86) (0.2g, 0.7mmol) in dichloromethane (10cm<sup>3</sup>) and acetyl chloride (0.06g, 0.05cm<sup>3</sup>, 0.7mmol) were stirred at room temperature for 20 h in the presence of a catalytic amount of DMAP and triethylamine (0.2g, 0.2cm<sup>3</sup>, 1.5mmol). The mixture was partitioned between dichloromethane (20cm<sup>3</sup>) and water (20cm<sup>3</sup>). The organic phase was collected, washed with water 10cm<sup>3</sup> (x2), 1%, NaOH 10cm<sup>3</sup> (x2), dried over magnesium sulfate and evaporated. The residual gum was chromatographed on silica eluting with 30% ethyl acetate in petrol to give the title compound as an orange oil (0.18g, 8.0%),  $\delta_H$  (CDCl<sub>3</sub>); 1.3 (6H, s, 2x Me), 1.7 (4H, m), 1.8 (2H, s), 2.1 (3H, s, Me), 2.2 (3H, s, Me), 3.5 (3H, m), 3.8 (3H, s, OMe), 4.1 (1H, m), 6.6 (1H, d,  $J=2.7$ , Ar-H), 6.7 (1H, d,  $J=2.7$ , Ar-H),  $\delta_C$  (CDCl<sub>3</sub>); 17.8 (3H), 21.3 (3H), 32.5, 32.7 (3H), 32.9 (3H), 37.4 (2H), 37.7 (2H), 37.9 (2H), 42.7 (2H), 49.0 (2H), 49.6, 55.5 (3H), 110.1 (1H), 113.7 (1H), 123.3, 132.2, 133.7, 151.8, 168.9.  $m/z$  (EI) % 316.2 (35.0, M<sup>+</sup>), 301.2 (10.0, M<sup>+</sup>-CH<sub>3</sub>), 273.2 (5.0, M<sup>+</sup>-COCH<sub>3</sub>).

Found :  $m/z$  (EI) 316.214188 C<sub>19</sub>H<sub>28</sub>N<sub>2</sub>O<sub>2</sub> (M<sup>+</sup>) requires : 316.215078.

**Synthesis of 1-heptanoyl-6<sup>1</sup>-methoxy-4<sup>1</sup>,4<sup>1</sup>,8<sup>1</sup>-trimethylspiro[piperidine-4,2<sup>1</sup>-(1,2,3,4-tetrahydroquinoline)] (50b)**

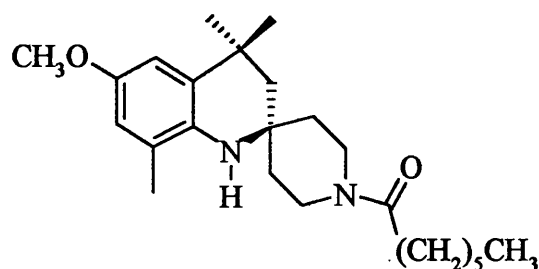

The amine (86) (0.24g, 0.9mmol) in dichloromethane (10cm<sup>3</sup>) and heptanoyl chloride (0.19g, 0.2cm<sup>3</sup>, 0.9mmol) were stirred at room temperature for 20 h in the presence of a catalytic amount of DMAP and triethylamine (0.3g, 0.4cm<sup>3</sup>, 2.6mmol). The mixture was partitioned between dichloromethane (20cm<sup>3</sup>) and water (20cm<sup>3</sup>). The organic phase was collected, washed with water 10cm<sup>3</sup> (x2), 1% NaOH 10cm<sup>3</sup> (x2), dried over magnesium sulfate and evaporated. The residual gum was chromatographed on silica eluting with 30% ethyl acetate in petrol to give the title compound as an orange oil (0.09g, 38%),  $\delta_{\text{H}}$  (CDCl<sub>3</sub>); 0.9 (3H, t,  $J=7.0$ ), 1.3 (12H, m), 1.6 (6H, s, 2x Me), 1.8 (2H, s), 2.2 (3H, s, Me), 2.3 (2H, q,  $J=7.2, 8.2$ ), 3.4 (3H, m), 3.8 (3H, s, OMe), 3.9 (1H, m), 6.6 (1H, d,  $J=2.8$ , Ar-H), 6.7 (1H, d,  $J=2.8$ , Ar-H),  $\delta_{\text{C}}$  (CDCl<sub>3</sub>); 13.9 (3H), 17.8 (3H), 25.2 (2H), 29.1 (2H), 31.5 (2H), 32.4 (2H), 32.8 (3H), 33.3 (3H) 37.5 (2H), 37.7 (2H), 41.9 (2H), 49.0 (2H), 49.6 (2H), 49.7, 55.5 (3H), 76.7, 110.1, 113.7, 123.2, 132.1, 133.7, 151.8, 171.6 m/z (EI) % 386.4 (20, M<sup>+</sup>).

Found : m/z (EI) 386.293434. C<sub>24</sub>H<sub>38</sub>N<sub>2</sub>O<sub>2</sub> (M<sup>+</sup>) requires : 386.293359.

**Synthesis of 1-lauroyl-6<sup>1</sup>-methoxy-4<sup>1</sup>,4<sup>1</sup>,8<sup>1</sup>-trimethylspiro[piperidine-4,2<sup>1</sup>-(1,2,3,4-tetrahydroquinoline)] (50c)**

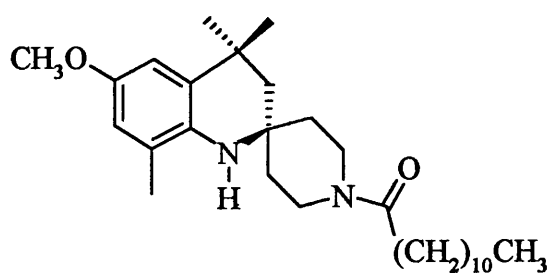

The amine (86) (0.2g, 0.7mmol) in dichloromethane (10cm<sup>3</sup>) and lauroyl chloride (0.16g, 0.2cm<sup>3</sup>, 0.7mmol) were stirred at room temperature for 6 h in the presence of a catalytic amount of DMAP and triethylamine (0.3g, 0.4cm<sup>3</sup>, 2.2mmol). The mixture was partitioned between dichloromethane (20cm<sup>3</sup>) and water (20cm<sup>3</sup>). The organic phase was collected, washed with water 10cm<sup>3</sup> (x2), 1% NaOH 10cm<sup>3</sup> (x2), dried and evaporated. The residual gum was chromatographed on silica eluting with 30% ethyl acetate in petrol to give the title compound as a yellow oil (0.19g, 95%),  $\delta_{\text{H}}$  (CDCl<sub>3</sub>); 0.9 (3H, t,  $J=6.8$ ), 1.3 (22H, m) 1.7 (6H, m), 1.8 (2H, s), 2.2 (3H, s, Me), 2.3 (2H, t,  $J=7.3$ ), 3.5 (3H, m), 3.7 (3H, m), 3.8 (1H, m), 6.7 (1H, d,  $J=2.5$  Ar-H), 6.8 (1H, d,  $J=2.5$  Ar-H),  $\delta_{\text{C}}$  (CDCl<sub>3</sub>); 14.1 (3H), 17.8 (3H), 22.6 (2H), 25.4 (2H), 29.1 (2H), 29.3 (2H), 29.4 (2H), 29.5 (2H), 29.6 (2H), 31.9 (2H), 32.5 (2H), 32.8 (3H), 32.9 (3H), 33.4 (2H), 37.5 (2H), 37.8 (2H), 38.1 (2H), 42.0 (2H), 49.1 (2H), 49.7, 55.6 (3H), 110.3, 113.7, 115.9, 123.2, 132.2, 133.8, 151.9, 171.7 m/z (FAB) % 456.4 (100, M<sup>+</sup>).

Found : m/z (FAB) : 456.3717 C<sub>29</sub>H<sub>48</sub>N<sub>2</sub>O<sub>2</sub> (M<sup>+</sup>+1) requires : 456.3716.

**Synthesis of 1-oleoyl-6<sup>1</sup>-methoxy-4<sup>1</sup>,4<sup>1</sup>,8<sup>1</sup>-trimethylspiro[piperidine-4,2<sup>1</sup>-(1,2,3,4-tetrahydroquinoline)] (50d)**

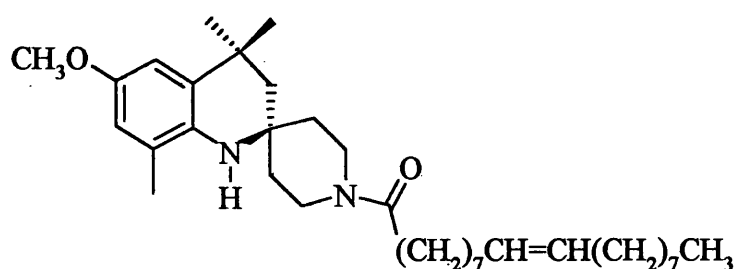

The amine (86) (0.15g, 0.6mmol) in dichloromethane (10cm<sup>3</sup>) and oleoyl chloride (0.16g, 0.2cm<sup>3</sup>, 0.6mmol) were stirred at room temperature for 6 h in the presence of a catalytic amount of DMAP and triethylamine (0.16g, 0.2cm<sup>3</sup>, 0.6mmol). The mixture was partitioned between dichloromethane (20cm<sup>3</sup>) and water (20cm<sup>3</sup>). The organic phase was collected, washed with water 10cm<sup>3</sup> (x2), 1% NaOH 10cm<sup>3</sup> (x2), dried with magnesium sulfate and evaporated. The residual gum was chromatographed on silica eluting with 30% ethyl acetate in petrol to give the title compound as a yellow oil (0.03g, 10%),  $\delta_{\text{H}}$  (CDCl<sub>3</sub>); 0.9 (3H, m, Me), 1.3 (20H, m), 1.7 (6H, m), 1.8 (2H, s), 2.0 (4H, m), 2.2 (3H, s, Me), 2.3 (2H, t,  $J=7.7$ ), 3.4 (2H, m), 3.6 (1H, m), 3.8 (3H, s, OMe), 5.4 (2H, m, CH=CH), 6.6 (1H, d,  $J=2.6$ , Ar-H), 6.7 (1H, d,  $J=2.6$ , Ar-H),  $\delta_{\text{C}}$  (CDCl<sub>3</sub>); 14.1 (3H), 17.9 (3H), 22.7 (2H), 25.4 (2H), 27.2 (2H), 29.2 (2H), 29.3 (2H), 29.4 (2H), 29.5 (2H), 29.5 (2H), 29.7 (2H), 29.8 (2H), 31.9 (2H), 32.6 (2H), 32.6 (2H), 32.8 (3H), 32.9 (3H), 33.5 (2H), 37.5 (2H), 37.9 (2H), 38.1 (2H), 42.0 (2H), 49.1 (2H), 50.0, 55.7 (3H), 110.2, 113.8, 123.3, 129.8, 130.0 130.1, 132.3, 133.8, 151.9, 171.8 m/z (EI) % 538.3 (12, M<sup>+</sup>).

Found : m/z (EI) 538.4499 C<sub>35</sub>H<sub>58</sub>N<sub>2</sub>O<sub>2</sub> (M<sup>+</sup>) requires : 538.4498.

**Synthesis of 4-carboxy-3,3-dimethylbutanoyl-6<sup>1</sup>-methoxy-4<sup>1</sup>,4<sup>1</sup>,8<sup>1</sup>-trimethylspiro[piperidine-4,2<sup>1</sup>-(1,2,3,4-tetrahydroquinoline)] (50e)**

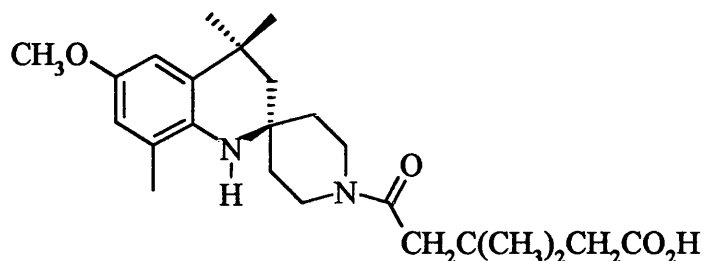

The amine (86) (0.20g, 0.7mmol) in dichloromethane (10cm<sup>3</sup>) and 3,3-dimethylglutaric anhydride (1.0g, 7.0mmol) were stirred at room temperature for 18 h in the presence of a catalytic amount of DMAP and triethylamine (3.0g, 4.0cm<sup>3</sup>, 30mmol). The mixture was partitioned between dichloromethane (20cm<sup>3</sup>) and water (20cm<sup>3</sup>). The organic phase was collected, washed with water 10cm<sup>3</sup> (x2), dried and evaporated. The residual gum was chromatographed on silica eluting with 80% ethyl acetate in petrol to give the title compound as a yellow oil (0.3g, 10%)  $\nu_{\max}/\text{cm}^{-1}$  3408, 1770, 1642cm<sup>-1</sup>,  $\delta_{\text{H}}$  (CDCl<sub>3</sub>); 1.1 (6H, s, 2xMe), 1.3 (6H, s, 2x Me), 1.7 (4H, m), 1.8 (2H, s), 2.2 (3H, s, Me), 2.5 (2H, s), 2.5 (2H, s), 3.5 (3H, m), 3.8 (3H, s, OMe), 3.8 (1H, m), 6.6 (1H, d,  $J=2.7$ , Ar-H), 6.7 (1H, d,  $J=2.7$ , Ar-H),  $\delta_{\text{C}}$  (CDCl<sub>3</sub>); 17.9 (3H), 29.2 (3H), 32.9 (3H), 32.9 (3H), 34.4 (3H), 38.1 (2H), 38.7 (2H), 40.8 (2H), 43.5 (2H), 47.3 (2H), 49.0 (2H), 49.5 (2H), 55.6 (3H), 110.2 (1H), 113.9 (1H), 129.6, 132.4, 133.4, 152.1, 171.6, 171.7, 173.1 m/z (EI) % 416.1 (38, M<sup>+</sup>), 274.1 (46, M<sup>+</sup>-COCH<sub>2</sub>CH(CH<sub>3</sub>)<sub>2</sub>CH<sub>2</sub>CO<sub>2</sub>H).

Found : m/z (EI) 416.266449 C<sub>24</sub>H<sub>36</sub>N<sub>2</sub>O<sub>4</sub> (M<sup>+</sup>) requires : 416.267508.

**Synthesis of 1-linolenyl-6<sup>1</sup>-methoxy-4<sup>1</sup>,4<sup>1</sup>,8<sup>1</sup>-trimethylspiro[piperidine-4,2<sup>1</sup>-(1,2,3,4-tetrahydroquinoline)] (50f)**

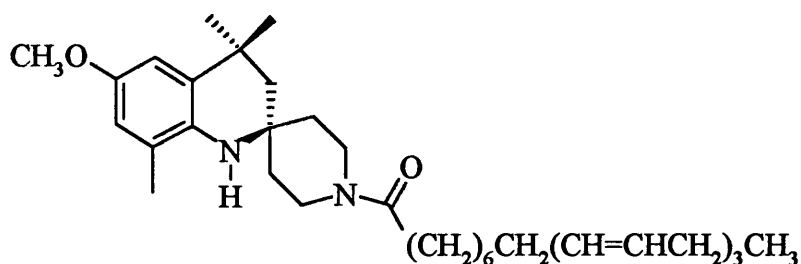

The amine (86) (0.17g, 0.6mmol) was placed in DCM (10cm<sup>3</sup>). Linoleic acid (0.2cm<sup>3</sup>, 0.6mmol) and DCC (0.14g, 7.2mmol) were added at 0°C. The reaction mixture was left to stir at 0°C for 1 h and allowed to reach room temperature and stirred for a further 20 h. Cold ethyl acetate was then added to the solution and the resulting solution left to stir in an ice bath for a further 15mins to allow the DCU to crystallise out. The solution was then filtered to remove any DCU. The residual gum was chromatographed on silica eluting with 30% ethyl acetate in petrol to give the title compound as an orange oil (0.05 g, 16%),  $\delta_{\text{H}}$  (CDCl<sub>3</sub>); 0.9 (3H, m), 1.4 (20H, m), 1.5 (4H, m), 1.8 (2H, s), 2.0 (3H, s, Me), 2.2 (2H, m), 2.3 (2H, m), 2.8 (3H, m), 3.4 (3H, m), 3.7 (3H, s, OMe), 3.8 (1H, m), 5.4 (6H, bs, 3x CH=CH), 6.6 (1H, d,  $J=2.6$ , Ar-H), 6.7 (1H, d,  $J=2.6$ , Ar-H),  $\delta_{\text{C}}$  (CDCl<sub>3</sub>); 14.1 (3H), 14.2 (3H), 17.8 (3H), 25.4 (2H), 25.5 (2H), 25.5 (2H), 27.2 (2H), 29.1 (2H), 29.3 (2H), 29.4 (2H), 29.5 (2H), 29.6 (2H), 32.5 (2H), 32.8 (3H), 32.9 (3H), 33.4 (2H), 37.8 (2H), 38.1 (2H), 42.0 (2H), 49.1 (2H), 49.7, 55.6 (3H),



110.2, 113.7, 123.2, 127.0, 127.7, 128.2, 129.7, 129.9, 130.2, 131.9, 132.2, 133.7, 151.8, 171.6. m/z (FAB) % 534.3 (80, M<sup>+</sup>).

Found : m/z (FAB) 534.417084 C<sub>35</sub>H<sub>54</sub>N<sub>2</sub>O<sub>2</sub> (M<sup>+</sup>+1) requires : 534.418529.

**The attempted synthesis of the troglitazone analogue (50g)**

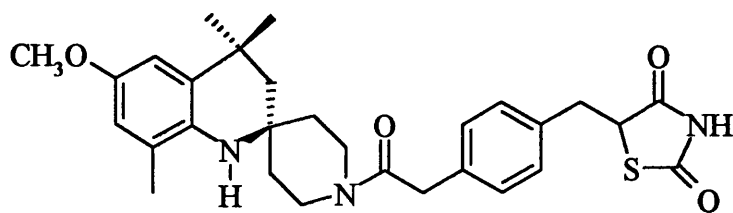

Compound (96) (0.2g, 0.7mmol) was placed in DMSO (20cm<sup>3</sup>) with the amine (86) (0.2g, 0.7mmol). Next sodium hydride (0.02g, 0.7mmol) was added. The reaction mixture was left to stir at room temperature for 24 h and then stirred at reflux for a further 2 h, before quenching with ice water (20cm<sup>3</sup>). The title compound could not be isolated.

**2- Cyclohexyl- 2-phenyl-3, 3, 5, 7-tetramethylindoline (64a)**

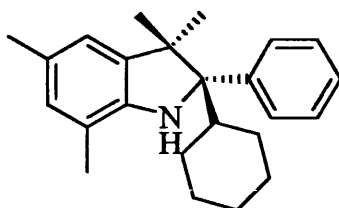

To a solution of indolenine (52) (1.5g, 6mmol) in THF (35cm<sup>3</sup>), sodium metal (0.6g, 24.0mmol) was added. The resulting complex was stirred for 4 h then chlorocyclohexane (0.7g, 6mmol) was added at -78°C, left at this temperature for 1 h before allowing to reach to room temperature. The mixture was stirred for 20 h. It was then treated with saturated ammonium chloride and water, extracted with ether 20cm<sup>3</sup> (x2) and the combined extracts were dried and evaporated to yield the title compound as a colourless oil (0.04g, 2.7%),  $\delta_{\text{H}}$  (CDCl<sub>3</sub>); 0.5 (3H, s, Me), 0.9 (11H, m), 1.5 (3H, s, Me), 2.2 (3H, s, Me), 2.2 (3H, s, Me), 3.7 (1H, s, NH), 6.6 (1H, s, Ar-H), 6.7 (1H, s, Ar-H), 7.3 (5H, m, Ar-H),  $\delta_{\text{C}}$  (CDCl<sub>3</sub>); 16.8 (3H), 20.1 (3H), 21.0 (3H), 26.6 (2H), 27.0 (2H), 28.5 (2H), 30.1 (2H), 31.4 (3H), 34.1, 38.1, 46.2, 76.5, 116.0, 118.6, 126.0, 127.8, 128.5, 132.7, 138.1, 144.6, 145.2 m/z (EI) % 333.2 (10, M<sup>+</sup>)

Found : m/z (EI) 333.245224 C<sub>24</sub>H<sub>31</sub>N (M<sup>+</sup>) requires : 333.2345650.

**3,3,5,7-Tetramethyl-2-(4-cyclohexylphenyl)indoline (65a):**

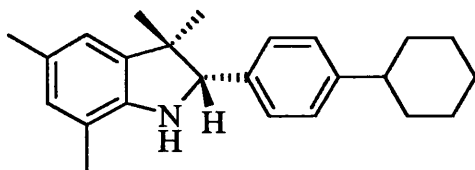

$\delta_{\text{H}}$  ( $\text{CDCl}_3$ ); 1.3 (1H, m), 1.4 (4H, m), 1.5 (6H, s, 2xMe), 1.7 (1H, m), 1.9 (4H, m), 2.3 (3H, s, Me), 2.5 (1H, m), 2.6 (3H, s, Me), 6.9 (2H, d,  $J=1.9$ , Ar-H), 7.3 (2H, d,  $J=2.0$ , Ar-H), 8.1 (2H, ,  $J=2.0$ , Ar-H),  $\delta_{\text{C}}$  ( $\text{CDCl}_3$ ); 16.7 (3H), 21.5 (3H), 24.9 (2H), 26.1 (3H), 26.8 (3H), 34.2 (4H), 44.5 (4H), 53.3, 118.9, 126.9, 128.1, 129.6, 130.0, 131.4, 135.2, 147.7, 149.7, 150.2, 184.0.

**3,3,5,6-Tetramethyl-2-phenylindoline (64i)**

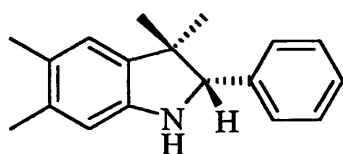

(0.32g, 21%),  $\delta_{\text{H}}$  ( $\text{CDCl}_3$ ); 0.7 (3H, s, Me), 1.4 (3H, s, Me), 2.1 (3H, s, Me), 2.3 (3H, s, Me), 3.8 (1H, bs), 4.5 (1H, s), 6.7 (2H, s, Ar-H), 7.3 (3H, m, Ar-H), 7.5 (2H, m, Ar-H),  $\delta_{\text{C}}$  ( $\text{CDCl}_3$ ); 16.6 (3H), 20.9 (3H), 24.4 (3H), 26.6 (3H), 45.5, 74.6, 118.2, 120.5, 127.3, 127.5, 128.0, 128.3, 128.9, 137.6, 140.2, 145.4.

## 2- Benzyl- 2-phenyl-3, 3, 5, 7-tetramethylindoline (64b)

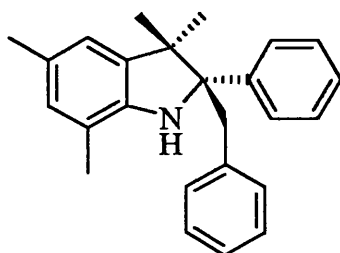

To a solution of indolenine (52) (1.0g, 4.0mmol) in THF (35cm<sup>3</sup>), sodium metal (0.37g, 16.0mmol) was added. The resulting complex was stirred for 4 h then benzyl bromide (0.46cm<sup>3</sup>, 4.0mmol) was added at room temperature. The mixture was stirred for 20 h. It was then treated with saturated ammonium chloride and water, extracted with ether 20cm<sup>3</sup> (x2) and the combined extracts were dried and evaporated to yield the title compound as a colourless oil (0.2g, 21.0%),  $\nu_{\max}/\text{cm}^{-1}$  3350cm<sup>-1</sup>,  $\delta_{\text{H}}$  (CDCl<sub>3</sub>); 0.7 (3H, s, Me), 1.3 (3H, s, Me), 2.3 (3H, s, Me), 2.4 (3H, s, Me), 4.1 (1H, d,  $J=16.9$ ), 4.2 (1H, s, NH), 4.30 (1H, d,  $J=16.9$ ), 6.75 (2H, s, Ar-H), 7.2, 10H, m, Ar-H),  $\delta_{\text{C}}$  (CDCl<sub>3</sub>); 19.9 (3H), 20.6 (3H), 26.1 (3H), 28.4 (3H), 44.1, 51.1 (2H), 78.6, 118.2, 121.1, 126.6, 127.2, 127.5, 127.8, 128.0, 128.2, 128.4, 128.4, 128.5, 129.7, 131.8, 138.8, 139.0, 139.5, 146.0,  $m/z$  (EI) % 326 (15, M<sup>+</sup>-Me), 341.2 (40, M<sup>+</sup>),

Found :  $m/z$  (EI) 341.213608 C<sub>25</sub>H<sub>27</sub>N (M<sup>+</sup>) requires : 341.214350.

Also obtained was the indoline (64i) (0.26g, 26 %), formed by reduction of the indolenine (52) during the reaction.

**2- Allyl-2-phenyl-3, 3, 5, 7-tetramethylindoline (64c)**

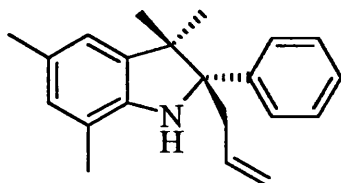

To a solution of indolenine (52) (1.0g, 4.0mmol) in THF (35cm<sup>3</sup>) sodium metal (0.37g, 16.0mmol) was added. The resulting complex was stirred for 4 h then allyl bromide (0.48g, 0.35cm<sup>3</sup>, 4.0mmol) was added at room temperature. The mixture was stirred for 30 h. It was then treated with saturated ammonium chloride and water, extracted with ether 20cm<sup>3</sup> (x2) and the combined extracts were dried and evaporated to yield a colourless oil of the title compound (0.01g, 1%),  $\delta_{\text{H}}$  (CDCl<sub>3</sub>); 0.7 (3H, s, Me), 1.4 (3H, s, Me), 2.3 (3H, s, Me), 2.4 (3H, s, Me), 3.4 (1H, s, NH), 4.5 (2H, m), 5.0 (2H, m, CH=CH<sub>2</sub>), 5.8 (1H, m, CHCH<sub>2</sub>), 6.7 (2H, s, Ar-H), 7.3 (5H, m, Ar-H),  $\delta_{\text{C}}$  (CDCl<sub>3</sub>); 19.8 (3H), 20.7 (3H), 24.9 (3H), 26.2 (3H), 27.2 (3H), 29.7, 43.8, 50.4 (2H), 78.4, 117.7 (2H), 120.9, 127.3, 128.0, 128.1, 128.4, 128.5, 131.5, 133.7, 138.7, 139.7, 145.4, m/z (EI) % 250.1 (20, M<sup>+</sup>-allyl), 276.1 (65, M<sup>+</sup>-Me), 291.2 (100, M<sup>+</sup>) and the reduced compound (64i) (0.27g, 27 %),  $\delta_{\text{H}}$  (CDCl<sub>3</sub>); 0.7 (3H, s, Me), 1.4 (3H, s, Me), 2.1 (3H, s, Me), 2.3 (3H, s, Me), 3.8 (1H, bs), 4.5 (1H, s), 6.7 (2H, s, Ar-H), 7.3 (3H, m, Ar-H), 7.5 (2H, m, Ar-H),  $\delta_{\text{C}}$ (CDCl<sub>3</sub>); 16.6 (3H), 20.9 (3H), 24.4 (3H), 26.6 (3H), 45.5, 74.6, 118.2, 120.5, 127.3, 127.5, 128.0, 128.3, 128.9, 137.6, 140.2, 145.4, m/z (EI) % 276.1 (65, M<sup>+</sup>-Me), 291.2 (100, M<sup>+</sup>).

Found : m/z (EI) 291.198265 C<sub>21</sub>H<sub>25</sub>N (M<sup>+</sup>) requires : 291.198700.

## 2-Acetyl-2-phenyl-3,3,5,7-tetramethylindoline (64d)

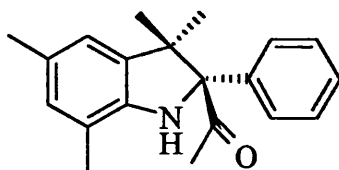

To a solution of indolenine (52) (1.5g, 6.0mmol) in THF (35cm<sup>3</sup>) was added, sodium metal (0.6g, 24mmol). The resulting complex was stirred for 4 h then acetic anhydride (0.6g, 0.6cm<sup>3</sup>, 6.0mmol) was added at -78°C, left at this temperature for 1 h before allowing to reach to room temperature. The mixture was stirred for 20 h. It was then treated with saturated ammonium chloride and water, extracted with ether 20cm<sup>3</sup> (x2) and the combined extracts were dried and evaporated to yield the title compound as a brown oil (0.2g, 13%),  $\nu_{\max}/\text{cm}^{-1}$  1668cm<sup>-1</sup> 3346cm<sup>-1</sup>,  $\delta_{\text{H}}(\text{CDCl}_3)$ ; 0.9 (3H, s, Me), 1.6 (3H, s, Me), 2.2 (3H, s, Me), 2.3 (3H, s, Me), 2.3 (3H, s, Me), 4.9 (1H, s), 7.2 (2H, s, Ar-H), 7.3 (5H, m, Ar-H),  $\delta_{\text{C}}(\text{CDCl}_3)$ ; 20.7 (3H), 21.1 (3H), 22.4 (3H), 23.3 (3H), 24.8 (3H), 31.6 (3H), 46.3, 77.8, 120.4, 126.7, 126.8, 127.7, 127.7, 128.0, 128.1, 128.2, 128.4, 128.5, 129.7, 130.7, 135.4, 139.1,  $m/z$  (EI) % 249.1 (52, M<sup>+</sup>-MeCO), 293.1 (37, M<sup>+</sup>).

Found :  $m/z$  (EI) 293.1766551 C<sub>20</sub>H<sub>23</sub>NO (M<sup>+</sup>) requires : 293.177965.

**2(3-Methylbut-2-enyl)-2-phenyl-3,3,5,7-tetramethylindoline (64f)**

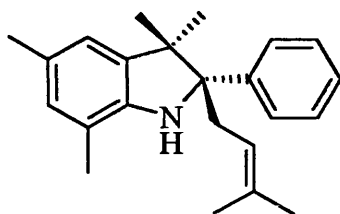

To a solution of indolenine (52) (1.0g, 4.0mmol) in THF (35cm<sup>3</sup>) was added sodium metal (0.4g, 16.0mmol). The resulting complex was stirred for 4 h then 4-bromo-2-methylbutene (0.40cm<sup>3</sup>, 4.0mmol) was added at room temperature. The mixture was stirred for 20 h. It was then treated with saturated ammonium chloride and water, extracted with ether 20cm<sup>3</sup> (x2) and the combined extracts were dried and evaporated to yield the title compound as a colourless oil (0.01g, 1.0%),  $\delta_{\text{H}}$  (CDCl<sub>3</sub>); 0.6 (3H, s, Me), 1.3 (3H, s, Me), 1.4 (3H, s, Me), 1.6 (3H, s, Me), 2.3 (3H, s, Me), 2.4 (3H, s, Me), 3.5 (1H, m), 4.2 (2H, d,  $J=8.1$ , CH<sub>2</sub>CH), 5.2 (1H, m, =CH), 6.7 (2H, s, Ar-H), 7.3 (5H, m, Ar-H),  $\delta_{\text{C}}$  (CDCl<sub>3</sub>); 17.9 (3H), 19.8 (3H), 20.7 (3H), 25.6 (3H), 26.2 (3H), 26.9 (3H), 43.7, 45.2 (2H), 78.2, 78.4, 110.4, 119.5, 119.8, 120.8, 127.2, 127.9, 128.1, 128.4, 131.5, 135.2, 138.8, 145.5, 148.4,  $m/z$  (EI); % 319.3 (97, M<sup>+</sup>).

Found :  $m/z$  (EI) 319.229546 C<sub>23</sub>H<sub>29</sub>N (M<sup>+</sup>) requires : 319.230000.

## 2-Isopropyl- 2-phenyl-3, 3, 5, 7-tetramethylindoline (64g)

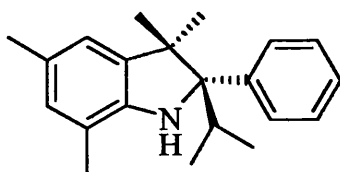

To a solution of indolenine (52) (2.0g, 8.0mmol) in THF (35cm<sup>3</sup>) was added sodium metal (0.7g, 32.0mmol). The resulting complex was stirred for 4 h then isopropyl iodide (0.7g, 0.80 cm<sup>3</sup>, 8.0mmol) was added at room temperature. The mixture was stirred for 20 h. It was then treated with saturated ammonium chloride and water, extracted with ether 20cm<sup>3</sup> (x2) and the combined extracts were dried and evaporated to yield the title compound as a colourless powder (0.02g, 1.0%), mp: 120-121°C,  $\delta_{\text{H}}$  (CDCl<sub>3</sub>); 0.6 (3H, s, Me), 0.7 (6H, d,  $J=6.4$  <sup>i</sup>Pr), 1.6 (3H, s, Me), 2.2 (3H, s, Me), 2.2 (3H, s, Me), 2.5 (1H, m, <sup>i</sup>PrCH), 3.7 (1H, s, NH), 6.6 (1H, s, Ar-H), 6.7 (1H, s, Ar-H), 7.3 (3H, m, Ar-H), 7.6 (2H, brs, Ar-H),  $\delta_{\text{C}}$  (CDCl<sub>3</sub>); 16.7 (3H), 19.1 (3H), 19.7 (3H), 20.3 (3H), 20.9 (3H), 31.4, 34.9 (3H), 47.6, 77.6, 116.0, 118.9, 126.0, 127.4, 127.8, 128.5, 138.0, 145.4 m/z (EI) % 293.2 (10, M<sup>+</sup>).

This product was accompanied by a minute quantity of 2,4<sup>1</sup>-di-isopropyl-2-phenyl-3,3,5,7-tetramethylindoline.

$\delta_{\text{H}}$ (CDCl<sub>3</sub>); 6.0 (2H, d,  $J=10.7$ ) 5.9 (2H, d,  $J=10.7$ ).

Found : m/z (EI) 293.213348 C<sub>21</sub>H<sub>27</sub>N (M<sup>+</sup>) requires : 293.214350.



### The preparation of *N*-(2-methylbenzylidene)-2-bromoaniline (66)

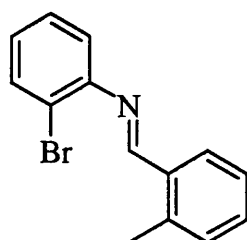

*p*-Tolualdehyde (3.0g, 3.1cm<sup>3</sup>, 25.0mmol) and 2-bromoaniline (3.4g, 25.0mmol) were reacted together under Dean-Stark conditions using toluene (35cm<sup>3</sup>) as solvent and a few *p*-toluenesulfonic acid crystals. The solvent was evaporated to afford the title compound as a green oil (5.0g, 73%),  $\nu_{\max}/\text{cm}^{-1}$  1606 cm<sup>-1</sup>,  $\delta_{\text{H}}$  (CDCl<sub>3</sub>); 2.4 (3H, s, Me), 7.0 (2H, m), 7.3 (3H, m), 7.6 (1H, d,  $J=7.3$ ), 7.8 (1H, d,  $J=8.1$ ), 7.8 (1H, d,  $J=7.9$ ), 8.3 (1H, s, CH=N),  $\delta_{\text{C}}$  (CDCl<sub>3</sub>); 21.6 (3H), 119.8, 126.4, 128.3, 129.5, 129.6, 129.7, 132.5, 132.9, 133.3, 142.2, 150.9, 161.5, 191.9;  $m/z$  (EI) % 274.0, 276.1 (55, 55, M<sup>+</sup>).

### Attempted preparation of 5,6-dihydrophenanthridine (67)

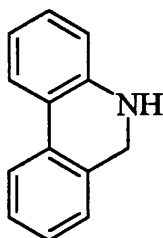

#### **Method 1**

The imine (66) (1.0g, 3.7mmol) was placed in THF (35cm<sup>3</sup>) and sodium metal (0.084g, 3.7mmol) was then added. The resulting complex was left to stir for 20 h

and then it was treated with saturated ammonium chloride solution and water, extracted with ether 10cm<sup>3</sup> (x2) and the combined extracts dried and evaporated. Unfortunately no single product was isolated.

## Method 2

The imine (66) (1.0g, 3.6mmol) was placed in THF (35cm<sup>3</sup>). Sodium metal (0.3g, 14.6mmol) was added and the mixture stirred for 4 h. The resulting solution was decanted from the excess sodium, placed in a flask and left on a sonic bath for 6 h. It was then treated with saturated ammonium chloride solution and water, extracted with ether 15cm<sup>3</sup> (x2) and the combined extracts dried and evaporated. Once again no products could be isolated.

### N-Benzylidene-3-bromopropylamine (77)

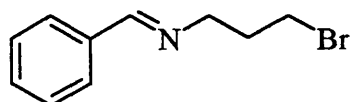

A solution of benzaldehyde (1.4cm<sup>3</sup>, 10.0mmol) in dichloromethane (35cm<sup>3</sup>) was treated with triethylamine (1.9cm<sup>3</sup>, 10.0mmol), 3 bromopropylamine hydrobromide (3.1g, 10.0mmol) and magnesium sulfate (2.0g). The mixture was stirred under reflux for 30 mins. After cooling, the drying agent was filtered off and the solvent evaporated off *in vacuo*. After the addition of dry ether (15cm<sup>3</sup>), the colourless precipitate was filtered and washed with dry ether. The filtrate was evaporated to give a pale yellow oil (1.75g, 77%),  $\nu_{\max}/\text{cm}^{-1}$  1646cm<sup>-1</sup>,  $\delta_{\text{H}}$  (CDCl<sub>3</sub>); 2.2 (2H, m), 3.5 (2H, t,  $J=6.4$ ), 3.7 (2H, t,  $J=6.3$ ), 7.3 (3H, m, Ar-H), 7.7 (2H, m, Ar-H), 8.3

(1H, s,  $\underline{\text{CH}}=\text{N}$ ),  $\delta_{\text{C}}$  ( $\text{CDCl}_3$ ); 31.6 (2H), 33.2 (2H), 58.7 (2H), 128.0, 128.5, 130.7, 132.6, 135.9, 162.0 m/z (EI) % 229.1/227.9 (100, 100,  $\text{M}^+$ ).

Found : m/z (EI) 227.013287/229.01330  $\text{C}_{10}\text{H}_{12}\text{NBr}$  ( $\text{M}^+$ ) requires : 227.013264/229.0132.

### Synthesis of 1-tert-butoxycarbonyl-4-(4-methoxy-2-methylanilino)piperidine

**(83)**

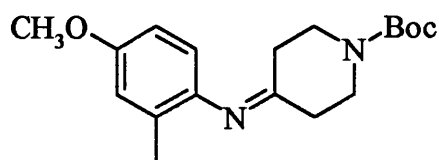

4-Methoxy-2-methylaniline ( $2.6\text{cm}^3$ , 0.02mol) was mixed with *N*-tert-butoxycarbonyl-4-piperidone (4.0g, 0.02mol) in toluene ( $50\text{cm}^3$ ). The solution was then refluxed for 4 h under Dean-Stark conditions in the presence of a few crystals of toluene-4-sulphonic acid. The solvent was then removed from the mixture and the product used directly in the next step;  $\nu_{\text{max}}/\text{cm}^{-1} = 1698\text{cm}^{-1}$  (C=N).

### Preparation of 2-methylallyllithium

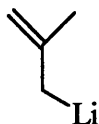

Lithium sand (0.14g, 0.02mol) was added in dry ether at  $0^\circ\text{C}$  into a 3 necked round bottom flask in the presence of argon. 3-Bromo-2-methyl-prop-2-ene (2.0g,

1.4cm<sup>3</sup>, 0.015mol) in ether was then added. The reaction was then left to warm up to room temperature and stirred at this temperature for a further 30 h before using directly in the next reaction. To check the formation of the Grignard a small aliquot was taken and quenched with benzaldehyde. Column chromatography eluting with 10% ethyl acetate in petrol afforded the alcohol (87) as the major product.

Compound (87)

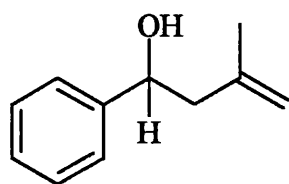

$\delta_{\text{H}}$  (CDCl<sub>3</sub>); 1.82 (3H, s, Me), 2.17 (1H, m), 2.4 (2H, m), 4.9 (3H, m), 7.3 (5H, m, Ar-H),  $\delta_{\text{C}}$  (CDCl<sub>3</sub>); 22.3 (3H), 48.3 (2H), 71.3, 114.0 (2H), 125.73 (2x 1H), 127.5, 128.4 (2x 1H).  $m/z$  (FAB) % 165.1 (15, M<sup>+</sup>+1).

### Preparation of 2-methylallylmagnesium bromide<sup>82</sup>

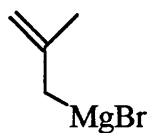

Magnesium turnings (0.72g, 0.03mol) were placed in a round bottom flask and stirred vigorously under argon for 24 h. Anhydrous ether (10cm<sup>3</sup>) was then added before placing a small iodine crystal in the solution. 3-Bromo-2-methylprop-2-ene (4.0g, 3.0cm<sup>3</sup>, 0.03mol) in ether (2.0cm<sup>3</sup>) was then added dropwise at room

temperature under argon. The resulting solution was then stirred for an additional hour before using directly in the next reaction. To check the formation of the Grignard a small aliquot was taken and quenched with benzaldehyde. Column chromatography eluting with 10% ethyl acetate in petrol yielded the alcohol (87).

**Attempted syntheses of 1-tert-butoxycarbonyl-4-(4-methoxy-2methylphenylamino)-4-(2-methylprop-2-enyl)piperidine (85)**

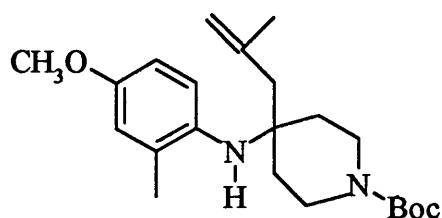

**Method 1**

The organolithium reagent made in the previous reaction was added to the imine (83) (7.5g, 0.02mol) and the reaction mixture was left to stir for 6 h at room temperature. The reaction mixture was then quenched with saturated ammonium chloride, and the phases were separated. The organic phase was washed with water 25cm<sup>3</sup> (x2), and dried using magnesium sulphate. The solvent was then removed under vacuum. Column chromatography was unrewarding.

**Method 2**

The organomagnesium reagent made in the previous reaction was added to the imine (83) (7.5g, 0.02mol) and the reaction mixture was left to stir for 6 h at room temperature. The reaction mixture was then quenched with saturated ammonium chloride, and the phases were separated. The organic phase was washed with

water 25cm<sup>3</sup> (x2), and dried using magnesium sulphate. The solvent was then removed under vacuum. Column chromatography was unsuccessful.

### Method 3

Imine (83) (3.18g, 10mmol) was added dropwise to the organolithium reagent (0.6g, 10mmol) prepared as above. Zinc chloride (10cm<sup>3</sup>, 1.0M solution) was then added. The reaction mixture was then stirred for a further 30 h. TLC indicated that no product had been formed.

### Method 4

Cerium(III) chloride heptahydrate (14.9g, 40mmol) was crushed in a mortar and placed in a flask. The flask was immersed in an oil bath and heated gradually to 135-140°C with evacuation. After maintaining constant temperature for an hour a magnetic stirrer was added and the cerium chloride completely dried *in vacuo* whilst stirring at the same temperature for a further hour.

While the flask was still hot, argon gas was introduced and the flask cooled in an ice bath. Cold THF was added whilst stirring vigorously. The ice bath was removed and the suspension was well stirred at room temperature overnight under argon. After this time the flask was immersed in ice and the organolithium was added (2.5g, 40mmol). After stirring for 1.5 h at 0°C the imine (83) (12.7g, 40mmol) was added dropwise. The reaction mixture was further stirred overnight. TLC indicated the absence of the desired product.

**Synthesis of 1-tert-butoxycarbonyl-4-(4-methoxy-2methylphenylamino)-4-(2-methylprop-2-enyl)piperidine (85)**

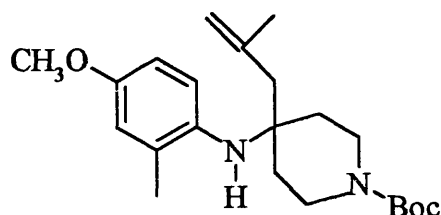

Sodium enriched lithium sand (0.6g, 0.08mol) was added to pentane (50cm<sup>3</sup>) under an atmosphere of argon gas. 3-chloro-2-methylprop-2-ene (5.4g, 6.0cm<sup>3</sup>, 0.06mol) was added to this. The imine (83) (12.0g) formed previously dissolved in THF (15cm<sup>3</sup>) was then added slowly, and the reaction was left to stir for 30 h under argon. The reaction mixture was quenched with saturated aqueous ammonium chloride, and the phases were separated. The organic phase was washed with water 25cm<sup>3</sup> (x2), and dried using magnesium sulphate. The solvent was then removed under vacuum, and the remaining oil purified by chromatography, eluting with 4% ethyl acetate in petrol to give the title compound (2.32g, 31%),  $\delta_{\text{H}}$  (CDCl<sub>3</sub>); 1.5 (9H, s, <sup>t</sup>Bu), 1.7 (3H, s, Me), 2.0 (4H, m), 2.1 (3H, s, Me), 2.5 (2H, s), 3.1 (4H, m), 3.7 (3H, s, OMe), 4.6 (1H, s), 4.9 (1H, s), 6.7 (3H, m, Ar-H),  $\delta_{\text{C}}$  (CDCl<sub>3</sub>); 18.1 (3H), 24.6 (3H), 28.0 (9H), 35.1 (4H), 39.1 (2H), 45.4 (4H), 53.7, 54.0 (3H), 78.9, 110.8, 114.7, 116.8, 125.2, 137.3, 141.4, 151.2, 154.3. m/z (EI) % 319.1 (55, M<sup>+</sup>-CH<sub>2</sub>(=CH<sub>2</sub>)CH<sub>3</sub>), 374 (15, M<sup>+</sup>). Found : m/z (EI) 374.25646 C<sub>22</sub>H<sub>34</sub>N<sub>2</sub>O<sub>3</sub> (M<sup>+</sup>) requires : 374.256943.

**and the side product (84)**

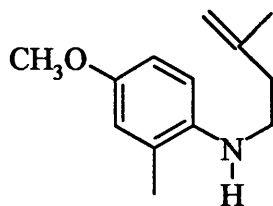

(0.5g),  $\delta_{\text{H}}$  ( $\text{CDCl}_3$ ); 1.8 (3H, s, Me), 2.2 (3H, s, Me), 3.7 (2H, s), 3.7 (3H, s, OMe), 4.9 (1H, s), 5.0 (1H, s), 6.5 (1H, d,  $J=8$ , Ar-H), 6.6 (2H, m, Ar-H),  $\delta_{\text{C}}$  ( $\text{CDCl}_3$ ); 17.6 (3H), 20.5 (3H), 50.5 (2H), 55.6 (3H), 110.6 (2H), 111.0, 111.4, 116.8, 123.5, 140.3, 143.0, 151.5,  $m/z$  (EI) % 136.0 (100,  $\text{M}^+$  -  $\text{CH}_2(=\text{CH}_2)\text{CH}_3$ ), 176.1 (17,  $\text{M}^+$  -  $\text{CH}_3$ ), 191.1 (73,  $\text{M}^+$ ).

**Synthesis of 6<sup>1</sup>-methoxy-4<sup>1</sup>,4<sup>1</sup>,8<sup>1</sup>-trimethylspiro[piperidine-4,2<sup>1</sup>-(1,2,3,4-tetrahydroquinoline)] (86, R=OMe)**

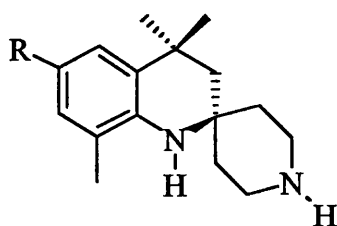

Concentrated sulfuric acid (5cm<sup>3</sup>) was added slowly to the amine (85) (0.5g, 1.6mmol) formed in the previous experiment in an ice bath, and the reaction mixture was warmed to for about 5 mins. Ice (9.0g) was added and the mixture basified with 6M ammonium hydroxide. The solution was then extracted three times with ethyl acetate, and the organic phases were combined, dried with magnesium sulfate, and evaporated. The crude product consisted of a mixture of



the required spiro compound and its O-Methyl derivative in the ratio of 4:3. These two compounds were separated by chromatography.

**(86, R = OMe)**,  $\nu_{\max}$  / $\text{cm}^{-1}$  3415 $\text{cm}^{-1}$  and 3300 $\text{cm}^{-1}$ ,  $\delta_{\text{H}}$  ( $\text{CDCl}_3$ ); 1.3 (6H, s, 2xMe), 1.6 (4H, m), 1.8 (2H, s), 2.2 (3H, s, Me), 2.5 (1H, brs, exchangeable), 2.9 (4H, m), 3.7 (1H, brs, exchangeable), 3.8 (3H, s, OMe), 6.5 (1H, d,  $J=3$ , Ar-H), 6.7 (1H, d,  $J=3$ , Ar-H),  $\delta_{\text{C}}$  ( $\text{CDCl}_3$ ); 17.5 (3H), 31.2 (3H), 32.2 (3H), 32.7 (3H), 38.4 (2H), 40.8 (2H), 41.8 (2H), 42.3 (2H), 49.4 (2H), 55.3 (3H), 57.5, 111.3, 113.3, 122.5, 124.8, 131.80, 134.0, 151.2 m/z (EI) % 274.1 (75,  $\text{M}^+$ ).

(Found : m/z (EI) 274.2046  $\text{C}_{17}\text{H}_{26}\text{N}_2\text{O}$  ( $\text{M}^+$ ) requires : 274.2045.

**(86, R = OH)**,  $\nu_{\max}$  / $\text{cm}^{-1}$  3470-3300 $\text{cm}^{-1}$ ,  $\delta_{\text{H}}$  ( $\text{CDCl}_3$ ); 1.3 (6H, s, 2xMe), 1.6 (4H, m), 1.7 (2H, s), 2.1 (3H, s, Me), 2.5 (1H, brs, exchangeable), 2.88 (4H, m), 3.6 (1H, brs, exchangeable), 6.4 (1H, d,  $J=2.5$ , Ar-H), 6.6 (1H, d,  $J=2.5$ , Ar-H),  $\delta_{\text{C}}$  ( $\text{CDCl}_3$ ); m/z (EI) % 260.1 (10,  $\text{M}^+$ ).

Found : m/z (EI) 260.1870  $\text{C}_{16}\text{H}_{24}\text{N}_2\text{O}$  ( $\text{M}^+$ ) requires : 260.1889.

### Synthesis of 5-(4-acetoxybenzylidene)thiazolidine-2,4-dione (98)

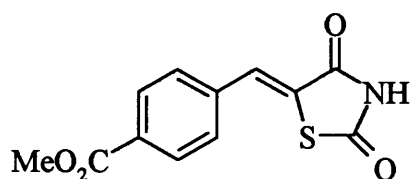

Methyl 4-formylbenzoate (1.8g, 11.0mmol), (1.3g, 11.0mmol) 2,4 thiazolidinedione (1.3g, 11.0mmol), piperidine (0.2 $\text{cm}^3$ ) and glacial acetic acid 0.02 $\text{cm}^3$  were placed in toluene and the solution was refluxed for 2 h. The solution

was left to cool in a fridge overnight, then filtered with cold ether yielding the title compound (2.5g, 89%) as a white powder. Mp: 200-201°C,  $\delta_{\text{H}}$  (CDCl<sub>3</sub>); 3.0 (3H, s, OMe) 6.8 (2H, d,  $J=8.4$ , Ar-H) 6.9 (1H, s, C=CH) 7.2 (2H, d,  $J=8.4$ , Ar-H),  $\delta_{\text{C}}$  (CDCl<sub>3</sub>); 50.8 (3H), 125.0, 128.4 (2H), 128.4 (2H), 128.9, 129.1, 135.9, 164.3, 166.2, 166.4. m/z (EI) % 263.0 (45, M<sup>+</sup>).

Found : m/z (EI) 263.025230 C<sub>12</sub>H<sub>9</sub>NO<sub>4</sub>S (M<sup>+</sup>) requires : 263.02576.

### Synthesis of 5-(4-acetoxybenzyl)thiazolidine-2,4-dione (99)

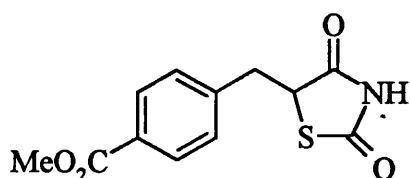

Compound (98) (2.0g, 7.7mmol) placed in dioxane (20cm<sup>3</sup>), 10% palladium on carbon (4.0g) was added and the resulting solution hydrogenated until hydrogen uptake ceased. The title compound (1.46g, 72%) was obtained as a colourless oil  $\nu_{\text{max}}$  1700cm<sup>-1</sup>,  $\delta_{\text{H}}$  (CDCl<sub>3</sub>); 3.2 (1H, m), 3.5 (1H, dd,  $J=4.4$ , 4.4), 3.9 (3H, s, OMe), 4.7 (1H, m, CHCH<sub>2</sub>), 7.4 (2H, d,  $J=8.4$ , Ar-H), 7.9 (2H, d,  $J=8.4$ , Ar-H), 9.0 (1H, brs),  $\delta_{\text{C}}$  (CDCl<sub>3</sub>); 36.4 (2H), 50.6 (1H), 51.0 (3H), 127.3, 127.9 (2H), 128.0 (2H), 140.6, 164.7, 170.1, 174.3. m/z (FAB) % 264.01 (40, M<sup>+</sup>+1).

Found : m/z (FAB) 264.032448 C<sub>12</sub>H<sub>10</sub>NO<sub>4</sub>S (M<sup>+</sup>+1) requires : 264.033055.

## Benzyl 4-formylbenzoate (104)<sup>98</sup>

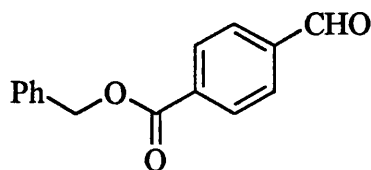

### Method 1

A solution of 4-formylbenzoic acid (1.5g, 10mmol), DCC (2.3g, 10mmol), benzyl alcohol (1.2g, 1.1cm<sup>3</sup>, 10mmol) and 4-pyrrolidinopyridine (0.15g, 1.0mmol) in dichloromethane (40cm<sup>3</sup>) was allowed to stand at room temperature until esterification was complete. The DCU was filtered off and the filtrate washed with water, 5% acetic acid and again with water, dried with magnesium sulfate and the solvent evaporated *in vacuo*. The title compound (0.25g, 10%), mp:141°C was obtained as a colourless solid by crystallisation from hexane in DCM.

### Method 2

The carboxylic acid (0.75g, 5.0mmol) and sodium hydrogen carbonate (0.7g, 8.3mmol) were placed in DMF (25cm<sup>3</sup>). Benzyl bromide (0.7g, 0.5cm<sup>3</sup>, 4.2mmol) was then added dropwise at room temperature. The reaction mixture was left to stir overnight, and then diethyl ether was added (20cm<sup>3</sup>). The solution was washed with water 5cm<sup>3</sup> (x2), saturated sodium hydrogen carbonate 5cm<sup>3</sup> (x2) and dried over magnesium sulfate. The organic phases were combined and evaporated to afford an oil, which was chromatographed on silica gel, eluting with 20% ethyl

acetate in petrol to afford the title compound (0.3g, 28%), mp: 141°C c.f. lit 142-144°C,  $\delta_{\text{H}}$  (CDCl<sub>3</sub>); 5.4 (2H, s), 7.4(5H, m), 8.0 (2H, d,  $J= 8.2$ ), 8.2 (2H, d,  $J=8.2$ ), 10.1 (1H, s),  $\delta_{\text{C}}$  (CDCl<sub>3</sub>); 67.3 (2H), 128.3, 128.5, 128.7, 129.5, 130.3, 135.0, 135.5, 139.2, 191.6. m/z (EI) % 240.2 (40, M<sup>+</sup>).

Found : m/z (EI) 240.078659, C<sub>15</sub>H<sub>12</sub>O<sub>3</sub>(M<sup>+</sup>) requires : 240.078644.

**Attempted preparation of 5-[4-(benzyloxycarbonyl)benzylidene]thiazolidine-2,4-dione (105)**

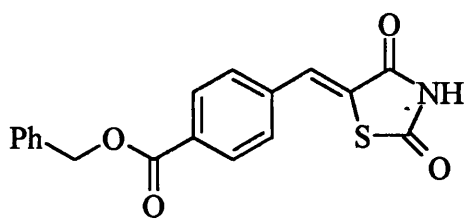

**Method 1**

Benzyl 4-formylbenzoate (3.0g, 12.5mmol), 2,4-thiazolidinedione (1.46g, 12.5mmol), piperidine (0.3cm<sup>3</sup>) and glacial acetic acid (0.03cm<sup>3</sup>) were placed in toluene (25cm<sup>3</sup>) and the solution was refluxed for 2 h under Dean-Stark conditions. The solution was placed in the fridge overnight and filtered with cold ether solution. None of the title compound could be isolated.

## Method 2

Benzyl 4-formylbenzoate (0.5g, 2.2mmol) was placed in DCM with sodium hydroxide (0.09g, 2.2mmol) in a small amount of water. Thiazolidine-2,4-dione (0.27g, 2.2mmol) was then added. The reaction mixture was stirred at room temperature for 16 h before quenching with water and extracting with DCM. However, starting material was isolated after column chromatography.

## Method 3

Thiazolidine-2,4-dione (0.27g, 2.2mmol) and sodium hydride (0.1g, 4mmol) were placed in DCM and stirred under nitrogen for a few mins. Benzyl 4-formylbenzoate (0.5g, 2.2mmol) was then added portionwise. The resulting solution was left to stir overnight. Again only starting material was isolated after column chromatography.

## Attempted synthesis of 5-(4-carboxybenzyl)thiazolidine-2,4-dione (106)

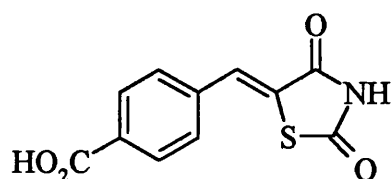

## Method 1

The ester (99) (0.5g, 1.9mmol) was dissolved in water and taken up in 2M sodium hydroxide solution. The reaction mixture was left to stir at 60°C for 3 h. The reaction mixture was then cooled with ice and concentrated hydrochloric acid was added dropwise. Ethyl acetate (15cm<sup>3</sup>) was added. The solution was washed with

water 10cm<sup>3</sup> (x2) and dried over magnesium sulfate. The organic phase was evaporated to afford an oil.

## Method 2

Compound (99) (0.28g, 1.2mmol) was placed in acetonitrile (20cm<sup>3</sup>), Trimethylsilyl iodide (0.47g, 0.30cm<sup>3</sup>, 2.4mmol) was then added. The resulting solution was stirred for 30 h at reflux, before quenching with water. The title compound could not be isolated.

## General procedure for enzyme hydrolysis of 5-(4-acetoxybenzyl)thiazolidine-2,4-dione (106)

The substrate was suspended in water and the enzyme was added. The solution was stirred between 25-40°C (depending on the enzyme) for 1 week. The enzyme was removed by filtration and the aqueous layer extracted with ethyl acetate and concentrated *in vacuo*.

## 1,2-Diamino-4,5-dimethylbenzene (108)<sup>99</sup>

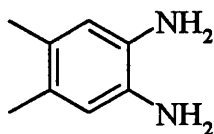

4,5-Dimethyl-2-nitroaniline (1.7g, 0.01mol) in ethanol (100cm<sup>3</sup>) was stirred under hydrogen in the presence of 10% Pd on carbon (0.18g) as catalyst for 16 h. The

catalyst was then removed by filtration and the filtrate evaporated to yield the title compound (1.3g, 93%) as a colourless solid mp: 125-127°C cf lit 125-126°C,  $\delta_{\text{H}}$  ( $\text{CDCl}_3$ ); 2.1 (6H, s, 2x Me), 3.1 (4H, s, 2x  $\text{NH}_2$ ), 6.5 (2H, s, 2x Ar-H)  $\delta_{\text{C}}$  ( $\text{CDCl}_3$ ); 18.8 (6H), 118.5, 127.8, 132.2.  $m/z$  (EI) % 136.1 (100,  $\text{M}^+$ ).

Found :  $m/z$  (EI) : 136.100578,  $\text{C}_8\text{H}_{12}\text{N}_2$  ( $\text{M}^+$ ) requires : 136.100048.

**1-[4-(*N*-tert-Butoxycarbonyl)piperidene]amino]-2-aminobenzene (110)**

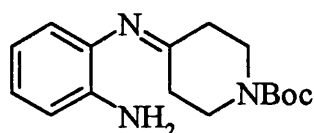

1,2-Phenylenediamine (1.1g, 10.0mmol) was mixed with *N*-tert-butoxy-carbonyl-4-piperidone (2.0g, 10.0mmol) in toluene (50 $\text{cm}^3$ ). The solution was then refluxed for 16 h under Dean-Stark conditions. The solvent was then removed from the mixture and the title compound isolated  $\nu_{\text{max}}/\text{cm}^{-1}$  1681 $\text{cm}^{-1}$  (C=N)

**Spiro[*N*-tert-butoxycarbonylpyridine-4,2<sup>1</sup>-benzimidazole] (111, R=H)**

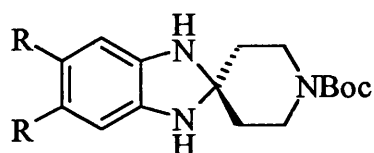

A hot solution of 1,2-phenylenediamine (0.5g, 5.0mmol) was prepared by boiling an aqueous solution of the diamine with activated charcoal for a few mins followed by filtration. *N*-Boc-piperidone (1.4g, 5.2mmol) was added with vigorous shaking

causing the formation of a heavy white precipitate in mins. The mixture was heated for a further 10 mins, cooled and the precipitate filtered off. It was washed with hot water and recrystallised from ethanol. The title compound was obtained as a white powder (1.0g, 67%) mp: 105-108 °C,  $\delta_H$  (CDCl<sub>3</sub>); 1.0 (9H, s, <sup>t</sup>Bu), 1.4 (4H, t,  $J=5.9$ ), 3.1 (4H, t,  $J=5.9$ ), 4.4, (2H, s, 2x NH), 6.1 (2H, m, Ar-H), 6.2 (2H, m, Ar-H),  $\delta_C$  (CDCl<sub>3</sub>); 28.0 (9H), 38.1 (4H), 40.7 (4H), 76.5, 79.3, 109.3 (2H), 119.6 (2H), 139.2, 154.3. m/z (FAB) % 289.3 (100, M<sup>+</sup>+1).

Found : m/z (FAB) 289.179039 C<sub>16</sub>H<sub>23</sub>N<sub>3</sub>O<sub>2</sub> (M<sup>+</sup>+1) requires : 289.179027.

**Spiro[N-tert-butoxycarbonylpyridine-4,2<sup>1</sup>-(4,6-dimethylbenzimidazole)] (111,**

**R=Me)**

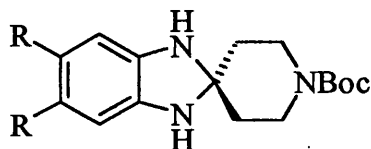

A hot solution of 4,5-dimethylbenzene-1,2-diamine (0.3g, 2.5mmol) was prepared by boiling an aqueous solution of the diamine with activated charcoal for a few mins followed by filtration. *N*-Boc piperidone (0.5g, 2.7mmol) was added with vigorous shaking causing the formation of a heavy white precipitate in mins. The mixture was heated for a further 10 mins, cooled and the precipitate filtered off. The title compound was obtained as an unstable yellow solid (0.18g, 26%),  $\delta_H$  (CDCl<sub>3</sub>); 1.5 (9H, s, <sup>t</sup>Bu), 1.8 (4H, t,  $J=5.7$ ), 2.1 (6H, s, 2x Me), 3.5 (4H, t,  $J=5.7$ ), 4.8 (2H, brs, 2x NH), 6.4 (2H, s, Ar-H),  $\delta_C$  (CDCl<sub>3</sub>); 21.3 (6H), 28.4 (9H),



32.0 (4H), 41.2 (4H), 79.8, 80.0, 104.5, 122.3 (2H), 147.0, 154.7, 155.0, 160.2.

m/z (FAB) % 317.3 (78, M<sup>+</sup>+1).

**2-Spiro[benzimidazolecyclohexane] (114, R=H)<sup>100</sup>**

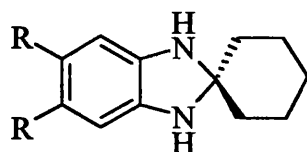

A hot solution of 1,2-phenylenediamine (0.5g, 5.0mmol) was prepared by boiling an aqueous solution of the diamine with activated charcoal for a few mins followed by filtration. Cyclohexanone (0.52cm<sup>3</sup>, 5.2mmol) was added with vigorous shaking causing the formation of a heavy white precipitate in mins. The mixture was heated for a further 10 mins, cooled and the precipitate filtered off. It was washed with hot water and recrystallised from ethanol. The title compound was obtained as yellow needle crystals (0.62g, 66%) mp:134-135°C, c.f. lit 130°C,  $\delta_{\text{H}}$  (CDCl<sub>3</sub>); 1.4 (10H, m), 3.6 (2H, s, 2x NH), 6.4 (2H, m, Ar-H), 6.4 (2H, m, Ar-H),  $\delta_{\text{C}}$  (CDCl<sub>3</sub>); 23.5 (4H), 25.4 (2H), 39.4 (4H), 80.1, 110.2, 120.5, 140.0. m/z (EI) % 188.2 (30, M<sup>+</sup>).

**Spiro[N-acetylpyridine-4,2<sup>1</sup>-(4,6-dimethylbenzimidazole] (117)**

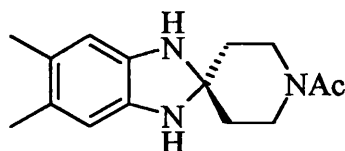

A hot solution of 4,5-dimethylbenzene-1,2-diamine (0.9g, 6.7mmol) was prepared by boiling an aqueous solution of the diamine with activated charcoal for a few mins followed by filtration. *N*-Acetyl-piperidone (1.0g, 0.7cm<sup>3</sup>, 7.0mmol) was added with vigorous shaking causing the formation of a heavy white precipitate in mins. The mixture was heated for a further 10 mins, cooled and the precipitate filtered off. The title compound was obtained as a brown solid (1.35g, 78%),  $\delta_{\text{H}}$  (CDCl<sub>3</sub>); 1.8 (4H, m), 2.1 (6H, s, Me), 2.1 (3H, s, Me), 3.5 (4H, m), 3.9 (2H, brs), 6.4 (2H, s, Ar-H). *m/z* (FAB) % 258.2 (100, M<sup>+</sup>+1).

Found : *m/z* (FAB) 258.160576, C<sub>15</sub>H<sub>20</sub>N<sub>3</sub>O (M<sup>+</sup>+1) requires : 258.160637.

### 1,2-Di-[*N*-(*N*-4-*tert*-butoxycarbonyl)glycinol)amino]4,5-dimethylbenzene (119)

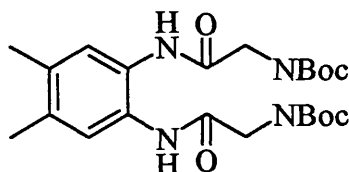

#### Method 1

1,2-Diamino-4,5-dimethylbenzene (0.5g, 3.7mmol) was added to *N*-Boc glycine (1.4g, 8.1mmol) and HOBt (1.2g, 9.2mmol) in DCM. The resulting solution was cooled to 0°C before the addition of DCC (10cm<sup>3</sup> 1M solution in DCM). The solution was left to reach room temperature and then allowed to stir for a further 16 h. The reaction mixture was quenched with water and extracted with ethyl acetate 5cm<sup>3</sup> (x2). The organic layers were combined, dried. The organic layers were combined and evaporated to afford an oil. This was chromatographed on

silica gel eluting with 50% ethyl acetate in petrol to yield the title compound as a colourless solid (0.3g, 22%).

## Method 2

1,2-Diamino-4,5-dimethylbenzene (0.5g, 3.7mmol) and *N*-Boc glycine (1.9g, 11mmol) were placed in DCM (50cm<sup>3</sup>) and stirred for a few mins under nitrogen. EDC (2.3g, 12mmol) was then added portionwise and the resulting solution was left to stir overnight. The volume of DCM was reduced and ethyl acetate was added. The solution was separated with potassium hydrogen sulphate 10cm<sup>3</sup> (x2), sodium hydrogen carbonate 10cm<sup>3</sup> (x2), sodium hydroxide 10cm<sup>3</sup> (x2), and finally brine 10cm<sup>3</sup> (x2). The organic layers were combined and evaporated to afford an oil which was chromatographed on silica gel eluting with 50% ethyl acetate in petrol to yield the title compound as a colourless solid (1.2g, 70%) mp: 115.5-117°C,  $\delta_{\text{H}}$  (CDCl<sub>3</sub>); 1.5 (18H, s, 2x <sup>t</sup>Bu), 2.1 (6H, s, 2x Me), 3.8 (2H, s, 2x CH<sub>2</sub>), 5.9 (2H, s, 2x NH<sub>Boc</sub>), 7.1 (2H, s, 2x Ar-H), 8.6 (2H, s, 2x CONH),  $\delta_{\text{C}}$  (CDCl<sub>3</sub>); 19.2 (6H), 28.4 (18H), 44.4 (4H), 80.1, 127.0 (2H), 127.7, 135.0, 156.4, 169.3. m/z (EI) % 450.3 (15, M<sup>+</sup>).

Found : m/z (EI) 450.248352 C<sub>22</sub>H<sub>34</sub>N<sub>4</sub>O<sub>6</sub> (M<sup>+</sup>) requires : 450.247835.

### 1,2-Di[(*N*-glycinoyl)amino]-4,5-dimethylbenzene (120)

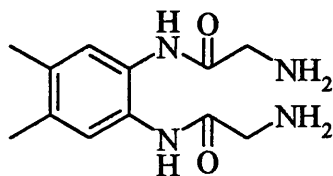

To a solution of compound (119) (1.2g, 2.6mmol) in DCM was slowly added a solution of 50% trifluoroacetic acid in DCM (25cm<sup>3</sup>). The resulting solution was then stirred at room temperature until no more carbon dioxide was given off. The title compound was obtained as a powder (0.28g, 44%) mp: 203-204 °C,  $\delta_{\text{H}}$  (DMSO); 2.2 (6H, s, 2x Me), 3.8 (4H, s, 2x CH<sub>2</sub>), 7.3 (2H, s, 2x Ar-H), 8.3 (4H, s, 2x NH<sub>2</sub>), 9.8 (2H, s, 2x NHCO),  $\delta_{\text{C}}$  (DMSO); 19.2 (6H), 41.1 (4H), 126.0 (2H), 127.7, 133.9, 165.4. m/z (FAB) % 251.2 (100, M<sup>+</sup>+1).

Found : m/z (FAB) 251.151134 C<sub>12</sub>H<sub>19</sub>N<sub>4</sub>O<sub>2</sub> (M<sup>+</sup>+1) requires : 251.150801.

**Attempted preparation of 1,2-di[(N-2-ethylamino)amino]-4,5-dimethylbenzene (121)**

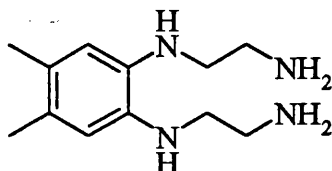

**Method 1**

1,2-Di-(N-glycinoyl)amino-4,5-dimethylbenzene (120) (0.9g, 4.1mmol) was added to a stirred suspension of lithium aluminium hydride (0.6g, 16.5mmol) in THF (20cm<sup>3</sup>) at 0 °C. The resulting solution was left to stir at reflux for 2-3 h, cooled and then left to stand overnight. The reaction mixture was then treated with 20% solution of sodium hydroxide to afford a dark yellow oil. Chromatographic purification of this material was unsuccessful.

### Method 2

To a mixture of 1,2-di-(*N*-glycinoyl)amino-4,5-dimethylbenzene (120) (0.5g, 2.0mmol) and 0.2mol% carbonyltris(triphenylphosphine)rhodium(I)hydride (0.0037g) in THF (2cm<sup>3</sup>) was added diphenylsilane (0.9cm<sup>3</sup>, 9.6mmol) at room temperature. After 24 h, the reaction mixture was diluted with diethylether and extracted with 1M HCl. The aqueous layer was basified with 15% sodium hydroxide solution and extracted with ethylacetate. The organic layer was dried over sodium sulfate and concentrated under reduced pressure to afford starting material.

### Method 3

A solution of borane complex (8cm<sup>3</sup>, 8.0mmol) (1M in THF) was placed in a flask under argon and cooled to 0°C. 1,2-Di-(*N*-glycinoyl)amino-4,5-dimethylbenzene (120) (0.5g in THF 25cm<sup>3</sup>) was then added over a 15 minute period. The resulting solution was refluxed for 16 h before addition of 2M HCl solution (4.5cm<sup>3</sup>) slowly. The THF was removed under reduced pressure, then the reaction mixture was neutralised with sodium hydroxide before extracting with diethyl ether. Only starting material was obtained.

**N-Dodecanoylaminoethanol (127)**

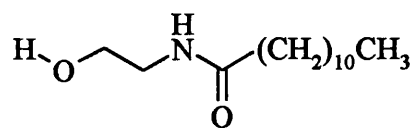

Ethanolamine (2.5g, 2.4cm<sup>3</sup>, 40mmol) was placed in DCM and stirred in the presence of triethylamine (2.0g, 2.8cm<sup>3</sup>, 20mmol) for a few mins. Lauroyl chloride (4.4g, 4.6cm<sup>3</sup>, 20mmol) was then added dropwise. The resulting solution was left to stir overnight, and then quenched with water. The organic product was taken up into DCM (20cm<sup>3</sup>), washed with water 5cm<sup>3</sup> (x2), sodium hydrogen carbonate 5cm<sup>3</sup> (x2), brine 5cm<sup>3</sup> (x2), dried over magnesium sulfate and evaporated to afford the title compound as a colourless solid (6.8g, 70%) mp: 80-82°C,  $\delta_{\text{H}}$  (CDCl<sub>3</sub>); 0.9 (3H, t,  $J=6.5$ ), 1.3 (16H, brs), 1.6 (2H, m), 2.2 (2H, m), 3.4 (2H, t,  $J=4.8$ , CH<sub>2</sub>NH), 3.6 (1H, brs, OH), 3.7 (2H, t,  $J=4.9$ ), 6.4 (1H, brs, NHCO),  $\delta_{\text{C}}$  (CDCl<sub>3</sub>); 14.1 (3H), 22.6 (2H), 25.7 (2H), 29.3 (8H), 29.3 (2H), 29.5 (2H), 29.6 (2H), 31.9 (2H), 36.6 (2H), 42.4 (2H), 46.0 (2H), 62.1 (2H), 174.6. m/z (FAB) % 244.3 (100, M<sup>+</sup>+1).

Found : C, 68.7; H 12.1; N, 5.83. C<sub>14</sub>H<sub>29</sub>NO<sub>2</sub> requires : C, 69.09; H, 12.01; N, 5.75.

### Attempted preparation of *N*-dodecanoylaminoacetaldehyde (128)

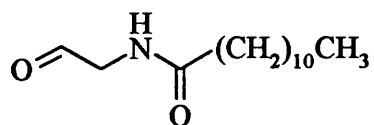

#### Method 1

PCC (6.9g, 32mmol) was dissolved in DCM (25cm<sup>3</sup>). *N*-Dodecanoylaminoethanol (127) (5.1g, 21mmol) was dissolved in a small amount of DCM and added to the reaction mixture in one portion. The resulting solution was stirred at room temperature for 1.5 h. The reaction mixture was diluted with diethyl ether (25cm<sup>3</sup>). The supernatant liquid was decanted off from the black gum. The black residue was washed thoroughly with portions of warm ether. The organic layer and ether washings were combined and filtered through a pad of fluorosil. The filtrate was evaporated to afford the dodecanoic acid as an oil

$$\nu_{\max}/\text{cm}^{-1} = 3302\text{cm}^{-1}.$$

#### Method 2

A solution of DCM (25cm<sup>3</sup>) and oxalyl chloride (1.0cm<sup>3</sup>, 11.0mmol) was placed in a 3 necked flask fitted with a calcium sulfate drying tube and 2 dropping funnels. One of the funnels contained dimethylsulfoxide (1.7cm<sup>3</sup>, 22.0mmol) dissolved in DCM (5cm<sup>3</sup>) and the other contained *N*-Dodecanoylaminoethanol (127) (2.4g, 10.0mmol) dissolved in DCM (10cm<sup>3</sup>). The dimethyl sulfoxide solution was added to the stirred oxalyl chloride solution at -50°C. The reaction mixture was stirred for 2 mins and the alcohol was added over 5 mins, stirring continued for a further

15 mins after which triethylamine (7.0cm<sup>3</sup>, 50.0mmol) was added and the reaction mixture stirred for 5 mins before being allowed to reach room temperature. IR spectroscopy indicated the formation of dodecanoic acid  $\nu_{\text{max}}/\text{cm}^{-1} = 3302\text{cm}^{-1}$ .

### Attempted preparation of (129)

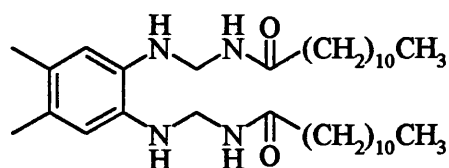

A flask was charged with aldehyde (128) (0.3g, 1.4mmol) and the diamine (108) (0.1g, 0.7mmol), anhydrous sodium acetate (0.2g, 2.7mmol), freshly activated 4 Å molecular sieves (1.4g) in absolute methanol (20 cm<sup>3</sup>). The sodium cyanoborohydride (0.17g, 2.7mmol) was added in a single portion, and the reaction was stirred at room temperature overnight. Excess 10% aqueous hydrochloric acid was added to carefully adjust to pH=2 to destroy excess sodium cyanoborohydride. The aqueous layer was adjusted to pH=10 with saturated sodium carbonate solution and extracted with ethyl acetate 10cm<sup>3</sup> (x2). The combined organic layers were washed with brine 10cm<sup>3</sup> (x2), dried with magnesium sulfate and concentrated *in vacuo*. The title compound was not isolated after column chromatography.



### Attempted preparation of 1-(*N*-dodecanoylamino)-2-bromoethane (130)

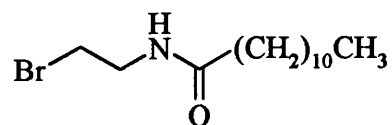

#### **Method 1**

Triphenyl phosphine (1.6g, 6.2mmol), bromine (0.9g, 0.3cm<sup>3</sup>, 5.7mmol) and imidazole (0.5g, 6.6mmol) were mixed together in dry DCM at 0°C under nitrogen. The suspension was stirred for 30 mins at 0°C. *N*-Dodecanoylaminoethanol (127) (1.0g, 4.1mmol) dissolved in DCM was then added dropwise. The solution was then stirred for a further 2 h before being poured into saturated sodium thiosulfate. The reaction mixture was extracted with DCM 10cm<sup>3</sup> (x2), dried with magnesium sulfate and evaporated at reduced pressure. Only triphenyl phosphine was isolated after chromatography of the oily product.

#### **Method 2**

To a solution *N*-dodecanoylaminoethanol (127) (1.5g, 6.2mmol) in 75cm<sup>3</sup> diethylether at 0°C was added phosphorus tribromide (1.7g, 0.6cm<sup>3</sup>, 6.2mmol) freshly distilled. The reaction mixture was left to stand at room temperature for a further 24 h before being used directly in the proceeding experiment. It should be noted that on washing this bromo compound even with ice briefly resulted in the formation of the alcohol.

## Experimental to Electrochemistry section

### N-Benzalaniline (68)<sup>58</sup>

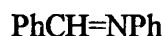

Benzaldehyde (3.2g, 3.1cm<sup>3</sup>, 30mmol) and aniline (2.8g, 2.7cm<sup>3</sup>, 30mmol) in DCM were left to stir in the presence of 4Å molecular sieves over the weekend. The solvent was removed and the residue washed with dry chloroform 10cm<sup>3</sup> (x2). The title compound was obtained as yellow crystals (4.3g, 79%), mp: 49-51°C cf lit value 50°C,  $\nu_{\text{max}}/\text{cm}^{-1} = 1640\text{cm}^{-1}$  (C=N),  $\delta_{\text{H}}$  (CDCl<sub>3</sub>); 7.2-7.3 (3H, m, Ar-H), 7.5 (5H, m, Ar-H), 7.9 (2H, m, Ar-H), 8.5 (1H, s, CH=N),  $\delta_{\text{C}}$  (CDCl<sub>3</sub>); 120.8, 125.9, 128.7, 128.8, 129.0, 129.1, 129.7, 131.3, 136.2, 152.0, 160.3. m/z (EI) % 180.1 (M<sup>+</sup>).

### General Electrolysis Procedure

The initial setup used a conventional 2 compartment H-type cell where a pool of mercury or a platinum gauze (4cm<sup>2</sup>) (previously cleaned in concentrated nitric acid) served as the cathode and either silver or platinum was chosen for the anode. The solvent was generally DMF, although acetonitrile was used on a few occasions and the supporting electrolyte was tetrabutylammoniumhexafluorophosphate (TBAHFP) (0.1M).

Since the potential for the reductions were close to the decomposition potential of the solvent and electrolyte, attempts were made to control the cathode potential using a 3 electrode arrangement where a rotating disc serves as the WE, the CE is silver and the reference is a SCE. The rotating disc electrode consists of a small platinum disc (1cm<sup>2</sup>), which was embedded centrally within a large cylinder composed of teflon. The cylinder was placed in the vessel containing the reaction mixture and rotated at a constant speed (typically 40Hz). The cathode was deaerated with argon. The electrolyses were stopped when the current had diminished by a considerable amount.

### **1,2-Diphenylpiperidine (69)**

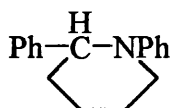

*N*-benzalaniline (conc 3.5mM) and dibromobutane (conc 35mM) were placed in DMF containing the supporting electrolyte (TBAHFP) (0.1M) and reduced at a rotating disc electrode (1cm<sup>2</sup>) for 8 h, until the current had fallen to nearly zero. The catholyte was then diluted with water, neutralised, extracted with ether and the solvent evaporated *in vacuo*. The electrolysis compounds were separated from the excess dibromoalkane by acid extraction. The title compound was obtained by column chromatography (0.1g, 2.0%),  $\delta_{\text{H}}$  (CDCl<sub>3</sub>); 1.5-2.1 (6H, m), 3.1-3.4 (2H, m), 4.5 (1H, t,  $J=4.5$ ), 6.7-7.3 (10H, m),  $\delta_{\text{C}}$  (CDCl<sub>3</sub>); 22.1 (2H), 25.6 (2H), 33.4 (2H), 50.5 (2H), 60.9, 118.7, 119.5, 125.8, 126.1, 127.2, 128.2, 128.7, 131.5, 143.5, 151.8.

**A typical procedure for the reductive alkylation of the indolenine (52)**

A solution of indolenine (52) (conc 3.5mM) and the alkyl halide (35mM) in the supporting electrolyte (0.1M) was reduced at a rotating disc electrode (1cm<sup>2</sup>) until the current had fallen to almost zero. The catholyte was then diluted with water and any products extracted with ether and dried over magnesium sulfate.

## 7.0 References

- 1 B. Halliwell, *Free. Rad. Res. Commun*, 1990, **9**, 1.
- 2 G. M. Campo, F. Squadrito, M. Iocolano, D. Altavilla, G. Calapai, B. Zingarelli, R. Scuri, and A. P. Caputi, *Free. Rad. Biol. Med*, 1994, **16**, 427.
- 3 C. Westerlund, A.-M. Ostlund-Lindqvist, M. Sainsbury, H. G. Shertzer, and P.-O. Sjoquist, *Biochem Pharm*, 1996, **51**, 1397.
- 4 M. S. Brown and J. I. Goldstein, *Science American*, 1984, **Nov**, 52.
- 5 R. Ross and J. A. Glomset, *N. Engl. J. Med*, 1976, **295**, 369.
- 6 S. Yla-Herttuala, W. Palinski, M. E. Rosenfeld, S. Parthasarathy, T. E. Carew, S. Butler, J. L. Witztum, and D. Steinberg, *J. Clin. Invest*, 1989, **84**, 1086.
- 7 J. A. Berliner and J. W. Heinecke, *Free. Rad. Biol. Med*, 1996, **20**, 707.
- 8 J. W. Heinecke, H. Rosen, and A. Chalt, *J. Clin. Invest*, 1984, **74**, 1890.
- 9 U. P. Steinbrecher, S. Parthasarathy, D. S. Leake, J. L. Witztum, and D. Steinberg, *Proc. Natl. Acad. Sci. USA*, 1984, **81**, 3883.
- 10 G. Scott, *Chemistry in Britian*, 1995, **Nov**, 879.
- 11 G. M. Campo, F. Squadrito, M. Iocolano, D. Altavilla, G. Calapai, B. Zingarelli, R. Scuri, and A. P. Caputi, *Free. Rad. Biol. Med*, 1994, **16**, 427.
- 12 U. P. Steinbrecher, H. Zhang, and M. Lougheed, *Free Rad Biol*, 1990, **9**, 155.
- 13 D. Steinberg, S. Parthasarathy, T. E. Carew, J. C. Khoo, and J. L. Witztum, *The New England Journal of Medicine*, 1989, **320**, 915.

- 14 H. Esterbauer, H. Puhl, M. Dieber-Rotheneder, G. Waeg, and H. Rabl,  
*Annal. Med*, 1991, **23**, 573.
- 15 , Data compiled by the Preclinical Research Laboratories, Astra Hassle AB,  
Molndal, Sweden.
- 16 S. M. Grundy, 'Cholesterol and Atherosclerosis: Diagnosis and Treatment',  
Gower Medical Publishing, 1990.
- 17 D. W. Brown, M. Mahon, A. Ninan, and M. Sainsbury, *J. Chem. Soc*,  
*Perkin Trans. 1*, 1997, 1699.
- 18 D. W. Brown, M. Lindquist, M. F. Mahon, B. Malm, G. N. Nilsson, A.  
Ninan, M. Sainsbury, and C. Weterlund, *J. Chem. Soc. Perkin Trans 1*,  
1997, 2337.
- 19 F. M. Miller and W. N. Schinske, *J. Org. Chem*, 1978, **43**, 3384.
- 20 R. E. Lyle and L. Skarlos, *J. Chem. Soc. Chem. Commun*, 1966, 644.
- 21 H. Illy and L. Funderburk, *J. Org. Chem*, 1968, **33**, 4283.
- 22 M. H. Palmer and P. S. McIntyre, *J. Chem. Soc*, 1969, **B**, 446.
- 23 C. W. Bird and A. Wee, *Tetrahedron*, 1985, **41**, 2019.
- 24 K. H. Pausacker, *J. Chem. Soc*, 1950, 621.
- 25 B. Robinson, *Chem Rev*, 1968, 227.
- 26 D. J. Hlasta and M. R. Bell, *Heterocycles*, 1989, **29**, 849.
- 27 M. Gharpure, A. Stoller, F. Bellamy, and G. Firanu, *Synthesis*, 1991, 1079.
- 28 P. Beak and M. Meyers, *Acc. Chem. Res*, 1986, **19**, 356.
- 29 A. R. Katritzky and S. Sengupta, *J. Chem. Soc. Perkin. Trans 1.*, 1989, 17.
- 30 a. R. Katritzky, P. Lue., and X.-X. Chen., *J. Org. Chem.*, 1990, **55**, 3688.

- 31 J. Yutong, J. Qiongzong, Z. Guoxin, and X. Zhang, *Tetrahedron Lett*, 1997, **38**, 215.
- 32 A. R. Katritzky and K. Akutagawa, *Tetrahedron Lett.*, 1985, **26**, 5935.
- 33 E. C. Ashby and T. N. Pham, *J. Org. Chem*, 1987, **52**, 1291.
- 34 W. F. Bailey, J. Jeffrey, J. Patricia, and T. Nurmi, *Tetrahedron Lett*, 1986, **27**, 1865.
- 35 M. Iwao and T. Kuraishi, *Heterocycles*, 1992, **34**, 1031.
- 36 G. E. Keck and J. B. Yates, *J. Am. Chem. Soc*, 1982, **104**, 5829.
- 37 G. E. Keck and E. J. Enholm, *J. Org. Chem*, 1985, **50**, 146.
- 38 H. A. Dieck and R. F. Heck, *J. Am. Chem. Soc*, 1974, **96**, 1133.
- 39 R. F. Heck, *J. Am. Chem. Soc.*, 1968, **90**, 5518.
- 40 R. F. Heck, *J. Am. Chem. Soc.*, 1969, **91**, 6707.
- 41 K. K. Vong, , PhD Thesis, University of Bath, 1987.
- 42 T. Izumi and A. Kasahara, *J. Heterocyclic. Chem.*, 1990, **27**, 1173.
- 43 M. Okubo and S. Ueda, *Bull. Chem. Soc. Jpn.*, 1972, **52**, 3346.
- 44 B. J. Wakefield, 'Organolithium Methods', Academic Press, 1988.
- 45 J. G. Smith and R. Turle, *J. Org. Chem*, 1972, **37**, 126.
- 46 M. S. Kharach and O. Reinmuth, 'Grignard reactions of non-metallic substances', Prentice Hall, 1954.
- 47 H. Gilman, J. E. Kirby, and C. R. Kinrey, *J. Am. Chem. Soc*, 1929, **51**, 2252.
- 48 R. C. Fuson and D. C. McKusick, *J. Am. Chem. Soc*, 1945, **67**, 597.

- 49 M. Okubo and S. Ueda, *Bulletin of the Chemical Society of Japan*, 1979, **52**, 3346.
- 50 J. G. Smith and G. E. F. Simpson, *J. Org. Chem*, 1975, **40**, 495.
- 51 J. G. Smith and D. J. D. J. Mitchell, *J. Am. Chem. Soc.*, 1976, 5045.
- 52 J. G. Smith and C. D. Veach, *Canadian Journal of Chemistry*, 1966, **44**, 2245.
- 53 J. G. Smith and C. D. Veach, *Canadian Journal of Chemistry*, 1966, **44**, 2497.
- 54 J. G. Smith and I. Ho, *J. Org. Chem*, 1971, **37**, 653.
- 55 M. Baizer, 'Organic Electrochemistry', Marcel Dekker, Inc, 1973.
- 56 K. Boujlel and J. Simonet, *Tetrahedron Lett*, 1985, **26**, 3005.
- 57 A. J. Fry and R. G. Reed, *J. Am. Chem. Soc.*, 1969, **91**, 6448.
- 58 C. Degrand, C. Grosdemouge, and P.-L. Compagnon, *Tetrahedron Lett.*, 1978, **33**, 3023.
- 59 C. Degrand, P.-L. Compagnon, G. Belot, and D. Jacquin, *J. Org. Chem.*, 1980, **45**, 1189.
- 60 J. M. Saveant and C. P. Andrieux, *J. Electroanal. Chem.*, 1971, **33**, 453.
- 61 A. C. Fisher, 'Electrode Dynamics', Oxford University Press, 1996.
- 62 H. Thies and H. Schonenberger, *Chem. Ber*, 1956, **89**, 1918.
- 63 G. Stork and S. R. Dowd, *J. Am. Chem. Soc.*, 1963, **85**, 2178.
- 64 R. W. Layer, *Chem. Rev*, 1963, **63**, 489.
- 65 I. Pattison, K. Wade, and B. K. Wyatt, *J. Chem. Soc.*, 1968, **A**, 837.
- 66 F. E. Scully, *J. Org. Chem.*, 1980, **45**, 1515.



- 67 M. Wada, Y. Sakurai, and K.-Y. Akiba, *Tetrahedron Lett.*, 1984, **25**, 1079.
- 68 E. W. Coluin and D. G. McGarry, *J. Chem. Soc. Chem. Commun.*, 1985,  
539.
- 69 M. A. Brook and Jahariger, *Synth. Commun.*, 1988, **18**, 893.
- 70 G. Cainelli, D. Giacomini, M. Panunzio, and P. Zarantunello, *Tetrahedron  
Lett.*, 1992, **33**, 7783.
- 71 M. Giammaruco, M. Taddei, and P. Ulivi, *Tetrahedron Lett.*, 1993, **34**,  
3635.
- 72 J. Thomas, *J. Bull. soc. Chim. Fr.*, 1973, 1300.
- 73 A. R. Katritzky, Q. Hong., and Z. Yang, *J. Org. Chem.*, 1994, **59**, 7947.
- 74 A. R. Katritzky, Q. Hong, and Z. Yang, *J. Org. Chem.*, 1995, **60**, 3405.
- 75 H. Nakamura, H. Iwama, and Y. Yamamoto, *J. Am. Chem. Soc.*, 1996, **118**,  
6641.
- 76 J. Ipaktschi and T. Eckert, *Chem. Ber.*, 1995, **128**, 1171.
- 77 T. Imamoto, N. Takiyama, K. Nakamura, T. Hatajima, and Y. Kamiya, *J.  
Am. Chem. Soc.*, 1989, **111**, 4392.
- 78 T. Imamoto, T. Kusumoto, Y. Tawarayama, Y. Sugiura, T. Mita, Y.  
Hatanaka, and M. Yokoyama, *J. Org. Chem.*, 1984, **49**, 3904.
- 79 T. Matsumoto, Y. Kobayashi, Y. Takemoto, Y. Ito, T. Kamijo, H. Harada,  
and S. Terashiima, *Tetrahedron Lett.*, 1990, **31**, 4175.
- 80 T. Matsumoto, Y. Takemoto, Y. Nakatani, Y. Ito, T. Kaimijo, H. Harada,  
and S. Terashima, *Chem. Pharm. Bull.*, 1991, **39**, 2550.

- 81 M. T. Reetz, R. Jaeger, R. Drewlies, and M. Hubel, *Angew. Chem. Int. Ed. Engl.*, 1991, **30**, 103.
- 82 H. D. Kaesz, 'Inorganic Syntheses: Polynuclear Transition Metal Complexes', 1989.
- 83 J. Cossy, C. Poitevin, and D. G. Pardo, *Synlett*, 1998, 251.
- 84 J. Cossy, C. Poitevin, and D. G. Pardo, *Tetrahedron Lett.*, 1998, **39**, 2965.
- 85 J. Rebek and D. Feitler, *J. Am. Chem. Soc.*, 1974, **96**, 1606.
- 86 J. Sheeman, *J. Am. Chem. Soc.*, 1955, **20**, 1067.
- 87 Y. Nagasaka, K. Kaku, K. Nakamura, and T. Kaneko, *Biochem. Pharm.*, 1995, **50**, 1109.
- 88 S. Puertas, F. Rebolledo, and V. Gotor, *J. Org. Chem.*, 1996, **61**, 6024.
- 89 T. Maugard, M. Remaud-Simeon, D. Petre, and P. Monsan, *Tetrahedron*, 1997, **53**, 5185.
- 90 S. M. Roberts, *J. Chem. Soc. Perkin. Trans. 1.*, 1999, 1.
- 91 G. A. Olah, S. C. Narang, B. G. Balaram Gupta, and R. Malhotra, *J. Org. Chem.*, 1979, **44**, 1247.
- 92 E. Haslam, *Tetrahedron*, 1980, **36**, 2409.
- 93 A. Hassner and V. Alexanian, *Tetrahedron Lett.*, 1978, **46**, 4475.
- 94 R. J. Frem and J. L. Rebsomer, *Chem. Rev.*, 1954, 593.
- 95 H. Suschitzky, K. E. Davies, G. E. Domany, M. Farhat, J. A. L. Herbert, and A. M. Jefferson, *J. Chem. Soc. Perkin. Trans. 1*, 1984, 2465.
- 96 A. Williams and I. T. Ibrahim, *J. Am. Chem. Soc.*, 1981, **103**, 7090.
- 97 Y. Ito, R. Kuwano, and M. Takahashi, *Tetrahedron Lett.*, 1998, **39**, 1017.

- 98 H. Hu, J. S. Mendoza, C. Lowden, L. M. Ballas, and W. P. Janzen, *Bio. Med. Chem.*, 1997, **5**, 1873.
- 99 'Dictionary of Organic Compounds'.
- 100 H. A. Staab and F. Vogtle, *Chem. Ber.*, 1965, **98**, 2681.