

University of Bath



PHD

Does the combination of buprenorphine/naltrexone have antidepressant efficacy in animal models?

Almatroudi, Abdulrahman

Award date:
2016

Awarding institution:
University of Bath

[Link to publication](#)

General rights

Copyright and moral rights for the publications made accessible in the public portal are retained by the authors and/or other copyright owners and it is a condition of accessing publications that users recognise and abide by the legal requirements associated with these rights.

- Users may download and print one copy of any publication from the public portal for the purpose of private study or research.
- You may not further distribute the material or use it for any profit-making activity or commercial gain
- You may freely distribute the URL identifying the publication in the public portal ?

Take down policy

If you believe that this document breaches copyright please contact us providing details, and we will remove access to the work immediately and investigate your claim.

Does the combination of buprenorphine/naltrexone have antidepressant efficacy in animal models?

Abdulrahman Mohammed Almatroudi

A thesis submitted for the degree of Doctor of Philosophy

University of Bath

Department of Pharmacy and Pharmacology

September 2016

COPYRIGHT

Attention is drawn to the fact that copyright of this thesis rests with its author. A copy of this thesis has been supplied on the condition that anyone who consults it is understood to recognise that its copyright rests with the author and they must not copy or use material from it except as permitted by law or with the consent of the author.

This thesis may not be consulted, photocopied or lent to other libraries without the permission of the author for 1 year from the date of acceptance of the thesis.

Signed: Abdulrahman Almatroudi

Date: 28.9.2016

Word count: 55,230

Table of contents

Table of contents.....	i
Table of Figures and Tables.....	vi
Acknowledgements.....	xxiv
Abstract.....	xxv
List of Abbreviations.....	xxvii
Chapter 1: GENERAL INTRODUCTION.....	1
1. Introduction	2
1.1. Opioid receptors.....	2
1.2. The kappa opioid receptors and signalling pathway (κ-receptor)....	3
1.2.1. κ-receptors and mitogen-activated protein kinase (MAPK) cascade activation.....	8
1.2.2. κ-receptor and ERK 1/2 MAPK activation.....	8
1.2.3. κ-receptor and p38 MAPK activation.....	9
1.2.4. κ-receptor and JNK MAPK activation.....	10
1.3. κ-receptor anatomical localisation.....	11
1.4. Effects κ-receptors on neurotransmitter release.....	14
1.5. Depression	16
1.6. The neurobiology of depression	18
1.6.1. Monoamine hypothesis.....	18
1.6.1.1. Serotonin and depression	21
1.6.1.2. Noradrenaline and depression	25
1.6.1.3. Dopamine and depression	26
1.6.2. Neurogenic theory of depression and other mechanisms...28	
1.7 Current antidepressant pharmacotherapies.....	29
1.7.1. Tricyclic antidepressants (TCAs).....	29
1.7.2. Monoamine oxidase inhibitors (MAOIs).....	29
1.7.3. The selective serotonin reuptake inhibitors (SSRIs) and Serotonin–norepinephrine reuptake inhibitor (SNRIs).....	31

1.7.4. Atypical antidepressants.....	32
1.7.5. Newer antidepressants.....	32
1.8. Limitations of the current antidepressant.....	33
1.9. Evidence of involvement of kappa opioid receptor in depression and anxiety.....	33
1.10. Limitations of the existing κ -receptors antagonist.....	40
1.11. Recent short-acting κ -receptors antagonists.....	41
1.12. Hypothesis and aims of the study.....	42
Chapter 2: General material and methods.....	44
2.1. Animals.....	45
2.2. Drugs	45
Chapter 3: Establishing the k-receptor antagonist properties of test compounds in vivo.....	47
3.1. Introduction.....	48
3.2. Aim.....	51
3.3. Method.....	52
3.3.1. Tail withdrawal test.....	52
3.3.2. Locomotor activity test.....	53
3.4. Statistical analysis.....	54
3.5. Result.....	55
3.5.1. Establishing that a combination dose of buprenorphine/naltrexone and single dose of BU10119 is a functional kappa opioid receptor antagonist.....	55
3.6. Discussion.....	67
Chapter 4: Establishing the rewarding properties of combination buprenorphine/naltrexone and single compound BU10119 in conditioned place preference (CPP) task.....	72
4.1. Introduction.....	73
4.2. Aim.....	76
4.3 Methods.....	77
4.3.1 Conditioned place preference (CPP).....	77
4.4 Results.....	80

4.4.1. Establishing the rewarding properties of combination buprenorphine/naltrexone and single compound BU10119 in conditioned place preference (CPP) task.....	80
4.5. Discussion.....	87
Chapter 5: Effects of combination buprenorphine/naltrexone and single compound BU10119 on depression and anxiety-related behaviour....	91
5.1. Can we model depression and anxiety in lab animals?.....	92
5.2. Validity of the animal models of depression and anxiety.....	92
5.3. Behavioural paradigms to assess depression- and anxiety-related behaviours.....	93
5.3.1. Forced swim test.....	93
5.3.2. Hyponeophagia paradigms.....	95
5.3.3. Elevated plus maze (EPM).....	96
5.3.4. The light-dark (LDB) box test.....	97
5.4. Aim.....	99
5.5. Methods.....	100
5.5.1. Forced swim test.....	100
5.5.2. Novelty-induced hypophagia.....	100
5.5.3. Elevated plus maze (EPM).....	101
5.5.4. Light dark box (LDB).....	101
5.6. Statistical analysis.....	101
5.7. Result.....	103
5.7.1. Effects of combination buprenorphine/ naltrexone in the FST.....	103
5.7.2. Effects of combination buprenorphine/ naltrexone in the NIH paradigm.....	106
5.7.3. Effects of combination buprenorphine/naltrexone in the EPM and LDB.....	109
5.7.4. Effects of BU10119 in the FST.....	112
5.7.5. Effects of BU10119 in the NIH paradigm.....	112
5.7.6. Effects of BU10119 in the EPM and LDB.....	115
5.8. Discussion.....	118

Chapter 6: Ability of κ-opioid receptor antagonists to block stress-induced effects.....	124
6.1. Introduction.....	125
6.2. Aim.....	127
6.3. Methods.....	128
6.3.1. Restraint Stress.....	128
6.3.2. Measurement of corticosterone level.....	128
6.3.3. Assessing stress-induced analgesia by warm water tail-withdrawal test.....	129
6.3.4. Behavioural testing.....	130
6.3.4.1. Force swim test (FST) and elevated plus maze (EPM)..	130
6.3.4.2. Sucrose preference test (SPT).....	132
6.3.5. Gene expression.....	132
6.3.5.1. Brain dissection	132
6.3.5.2 RNA isolation.....	132
6.3.5.3. One step reverse transcription PCR (RT-PCR).....	133
6.3.5.4. Quantitative real-time RT-PCR.....	135
6.4. Analysing quantitative real-time RT-PCR Data.....	136
6.5. Statistical analysis.....	136
6.6. Result.....	137
6.6.1. Acute and repeated restraint stress increase plasma corticosterone level.....	137
6.6.2. Effects of acute and repeated restraint stress on analgesia.....	137
6.6.3. Effects of restraint stress on behaviour in the elevated plus maze.....	143
6.6.4. Effects of restraint stress on behaviour forced swim test.....	143
6.6.5. Effects restraint stress on sucrose preference test (SPT).....	143
6.6.6. Effects of restraint stress on gene expression.....	149

6.7. Discussion.....	159
Chapter 7: General discussion.....	162
7.1. General Discussion.....	163
7.2 Clinical potential of buprenorphine/naltrexone and BU10119.....	163
7.3 Why are κ-antagonists likely to be antidepressant?.....	168
Reference.....	171
Appendix.....	217

Table of Figures and Tables

Chapter 1	1
Figure 1.1 Illustration diagram shows the site of action of endogenous opioid. (Adapted by permission from S.Baile.....)	2
Figure 1.2 Crystal packing and overview of the human κ -receptor structure in complex with JD ₁ c, and comparison with the inactive CXCR4 and β 2-AR structures.....	4
Table 1.1 κ -receptor agonists and their binding affinities μ , κ and δ (values extracted from IUPHAR receptor database.....)	5
Figure 1.3 κ -receptor-mediated signal transduction. Cartoon depicting the current status of the κ -receptor signal transduction pathways..	6
Table 1.2 Shows the characteristics of the cloned opioid receptors.....	7
Figure 1.4 κ -receptors modulate the interactions between major circuits involved in stress responses, anxiety, and addiction.....	12
Table 1.3 Relative proportions of the opioid receptors in several species.....	13
Figure 1.5 Summary of κ -receptor modulation and downstream signalling in NAc, Cartoon summary of the sites of κ -receptor modulation in a medium spiny neuron of the NAc and downstream effectors of κ -receptor activation.....	15
Figure 1.6 The possible current hypotheses of depression. In the top oval, the possible hypotheses of depression and their associated drug targets are listed. In the middle oval, the possible	

	biological courses involved in the etiology of depression are shown.....	19
Figure 1.7	Schematic diagram depicting the major pathways involved in the synthesis, release, re-uptake and metabolism of serotonin in serotonergic neurons.....	22
Figure 1.8	Cellular and molecular mechanisms of antidepressant action (red arrows). Antidepressants act by increasing levels of 5HT (blue circles) and/or NA (green circles), which is generally achieved via inhibition of the 5HT and/or NA transporters.....	30
Table 1.4	K-receptor agonists that have shown prodepressant-like behaviours in animal models of depression.....	35
Table 1.5	Summary of the results of opioid receptors affinities (K_i) and antagonist potencies (K_e) of GNTI, JD _T ic and norBNI from different laboratories.....	36
Table 1.6	K-receptor antagonists that have shown attenuation of stress, antidepressant- and anxiolytic-like behaviours in animal models.....	37
Figure 1.9	Chemical structures of buprenorphine and BU1119.....	43
Chapter 2	44
Table 2.1	Summary of the κ -receptors selectivity on μ - κ - δ and ORL-1 receptors (IUPHAR receptor database.....)	46

Chapter 3.....47

Figure 3.1 Antinociceptive effects of buprenorphine (Bup) (0.3,1 and 3 mg/kg) in the mouse tail withdrawal assay. Two-way repeated measures mixed model analysis was used. All values are mean \pm SEM, n= 6 per group. ** $p < 0.01$ as compared between Bup 3 mg/kg and all treatment groups ; *** $p < 0.$ as compared between Bup (1 and 3 mg/kg) and saline and Bup 0.3;## $p < 0.01$ and ;### $p < 0.001$ as compared between Bup 1 mg/kg and saline and Bup 0.3.....56

Figure 3.2 Locomotor activity in the open field in mice treated with buprenorphine (Bup) (0.3, 1and 3mg/kg) and naltrexone (NTX) (3mg/kg). One-way ANOVA was used. All values are mean \pm SEM, n= 6 per group.....57

Figure 3.3 Antinociceptive effects of buprenorphine (Bup 1mg/kg) were blocked by naltrexone (NTX) in the mouse tail withdrawal assay. (A) The time course of the experiment. (B) The antagonist effects of naltrexone (NTX) at 60 min post-administration of agonist. Naltrexone (NTX) dose-dependently blocked buprenorphine-induced antinociception (** $p < 0.01$; *** $p < 0.001$ compared to saline control. Two-way repeated measures mixed model analysis was used All values are mean \pm SEM, n= 5 per group.....58

Figure 3.4 Locomotor activity in the open field in mice treated with buprenorphine (Bup 1 mg/kg) combination with naltrexone (NTX 0.3, 1 and 3mg/kg). All values are mean \pm SEM, n=5 per group.....59

Figure 3.5 Antinociceptive effects of U50,488 (U50, 5 and 10 mg/kg) in the mouse tail-withdrawal assay. Two-way repeated measures

mixed model analysis was used. $***p < 0.001$ U50 10 mg/kg compared to saline control. All values are mean \pm SEM, n= 5 per group.....60

Figure 3.6 Antinociceptive effects of U50,488 (U50, 10 mg/kg) were blocked by naltrexone (NTX) in the mouse tail withdrawal assay. (A) The time course of the experiment. (B) The antagonist effects of naltrexone (NTX) at 60 min post-administration of agonist. Naltrexone (NTX) dose-dependently blocked U50,488-induced antinociception ($*p < 0.05$; $**p < 0.01$; $***p < 0.001$ U50 compared to saline control. Two-way repeated measures mixed model analysis was used All values are mean \pm SEM, n= 5 per group.....61

Figure 3.7 Antinociceptive effects of U50,488 (U50, 10 mg/kg) were blocked by naltrexone (NTX) in the mouse tail withdrawal assay. (A) The time course of the experiment. (B) The antagonist effects of naltrexone (NTX) at 60 min post-administration of agonist. Naltrexone (NTX) dose-dependently blocked U50,488-induced antinociception ($*p < 0.05$; $**p < 0.01$; $***p < 0.001$ U50 compared to saline control. Two-way repeated measures mixed model analysis was used All values are mean \pm SEM, n= 5 per group.....62

Figure 3.8 Duration of κ -antagonist effects of naltrexone (NTX) alone or naltrexone/ buprenorphine combination. Significant blockade of U50,488 induced antinociception is evident at 1 h post-administration and reversed by 24 h. At 8h post-administration, the combination of buprenorphine/naltrexone, produced a significant potentiation of U50-488-induced antinociception ($^^p < 0.001$ compared to all other treatment

groups; ### $p < 0.001$ for all treatment groups compared to NTX/Bup/saline controls; && $p < 0.01$ compared to NTX/Bup/saline controls and compared to NTX/Saline/U50 group. Two-way repeated measures mixed model analysis was used All values are mean \pm SEM, $n = 5$ per group.....64

Figure 3.9 Antinociceptive effects of buprenorphine (1mg/kg) was blocked CCAM (3 mg/kg) in the mouse tail withdrawal assay. CCAM was given 24 hr before Bup. Bup was administered 1 hr before starting the measurement. Two-way repeated measures mixed model analysis was used. All values are mean \pm SEM, $n = 5$ per group. * $p < 0.05$, ** $p < 0.01$ and *** $p < 0.001$ as compared to CCAM+Bup.....65

Figure 3.10 The irreversible μ -antagonist CCAM (3 mg/kg) administered 24 h before testing blocked the buprenorphine/ naltrexone (Bup/NTX) mediated potentiation of U50,488-induced antinociception at 8h post-administration (* $p < 0.05$ compared to U50 alone, @@@ $p < 0.001$ as compared to Bup/NTX combination + U50 group). Two-way repeated measures mixed model analysis was used. All values are mean \pm SEM, $n = 5$ per group.....65

Figure 3.11 Antinociceptive effects of buprenorphine (Bup, 1mg/kg) and U50,488 (U50, 10 mg/kg) are blocked by BU10119 in the mouse tail withdrawal assay. The time course of the experiments is shown (A,B, C). Locomotor activity in the open field in mice treated with BU10119 (0.3, 1 and 3mg/kg) (D). (A) Only buprenorphine (1 mg/kg) was able to increase latency time in the mouse tail withdrawal assay.(*** $p < 0.001$ as compared between Bup (1 mg/kg) and all groups). (B) Antinociceptive effects of U50,488 (10 mg/kg) was blocked by

BU10119 (1 and 3 mg/kg) and norBNI (1 mg/kg). (**p< 0.001 as compared to BU10119 (1 and 3 mg/kg) and norBNI (1mg/kg). ###p<0.001 as compared between all group and norBNI (1mg/kg)). (C) BU10119 (1 mg/kg) blocked buprenorphine and morphine-induced antinociception (**p< 0.001 compared to BUP; \$\$\$p< 0.001 to morphine). The irreversible μ -antagonist CCAM (3 mg/kg) administered 24 h before testing blocked buprenorphine and morphine-induced antinociception at 60 min post-administration (**p< 0.001 compared to BUP; ###p< 0.001 to morphine). Two-way repeated measures mixed model analysis was used. All values are mean \pm SEM, n= 5 per group.....67

Table 3.1 Table shows maximal stimulation of [35S] GTP γ S binding to opioid and ORL-1 receptors. Data are taken from Cueva et al. 2015.....70

Chapter 4.....72

Figure 4.1 Photo of the conditioned place preference (CPP) chamber.....78

Figure 4.2 The time line of the CPP experimental design. Naltrexone (NTX)(1 or 3 mg/kg) was injected 10 min before the injection of buprenorphine or saline. CCAM (3 mg/kg) was injected 24 hr before conditioning and 10 minutes between norBNI and CCAM injection were adopted. NorBNI (10 mg/kg) was injected in the 2nd and 5th day.....78

Figure 4.3 Conditioned place preference to buprenorphine (Bup, 1 mg/kg) in adult male CD1 mice, in the presence and absence of naltrexone (NTX) (1 and 3 mg/kg). In a 900

second test, animals in all treatment groups did not show a preference for either chamber during habituation (pre-conditioning). After 6 days of conditioning, buprenorphine significantly increased the time spent in the drug-paired chamber. The analysis was done by one-way ANOVA followed Unadjusted Least Significant Difference (ULSD) post hoc test. Values are mean \pm SEM, $n=8$ per group. * $p=0.05$ vs pre-condition gr.....81

Figure 4.4 Effects of buprenorphine (Bup), naltrexone (NTX) (10 mg/kg) and BU10119 (1 mg/kg) in conditioned place preference assay in adult male CD1 mice. Data are presented as preference for the drug (= time spent in the drug-paired side during test minus time spent in the drug-paired side at baseline (Naltrexone and BU10119), $n=9$ (Saline, Buprenorphine). The analysis was done by one-way ANOVA followed Unadjusted Least Significant Difference (ULSD)) post hoc test. Values are mean \pm SEM, $n=10$. * $p<0.05$ and ** $p<0.01$ as compared to saline.....82

Figure 4.5 Effects of buprenorphine (Bup) (1 mg/kg), BU10119 (1 mg/kg) and CCAM (3 mg/kg) alone or in combination in conditioned place preference assay in adult male CD1 mice. Data are presented as preference for the drug (= time spent in drug-paired side during test minus time spent in drug-paired side at baseline). The analysis was done by one-way ANOVA followed Unadjusted Least Significant Difference (ULSD)) post hoc test. Values are mean \pm SEM, SEM, $n=9$. ** $p<0.01$ as compared to saline.....84

Figure 4.6 Effects of morphine (10 mg/kg), buprenorphine (Bup) (1mg/kg) alone or in combination with CCAM (3 mg/kg) in conditioned place preference assay in adult male CD1 mice.

CCAM (3 mg/kg) was administered 24 hr before morphine and Bup. Data are presented as preference for the drug (= time spent in drug-paired side during test minus time spent in drug-paired side at baseline) \pm SEM, n=8. The analysis was done by unpaired Student t-test. *p<0.05 as compared to morphine.....85

Figure 4.7 Effects of buprenorphine (Bup) (0.3 mg/kg) alone and in combination with CCAM (3 mg/kg) in conditioned place preference assay in adult male CD1 mice. CCAM (3 mg/kg) was administered 24 hr before Bup. Data are presented as preference for the drug (= time spent in the drug-paired side during test minus time spent in drug-paired side at baseline). The analysis was done by 1-way ANOVA followed Unadjusted Least Significant Difference (ULSD) post hoc test. Values are mean \pm SEM, n=10 (Bup), n=9 (saline and Bup with CCAM). ***p<001 as compared to saline treated group.....86

Figure 4.8 Effects of buprenorphine (Bup) (0.3 mg/kg), CCAM (3 mg/kg), norBNI (10 mg/kg) alone and in combination in conditioned place preference assay. Data are presented as a preference for the drug (= time spent in the drug-paired side during test minus time spent in the drug-paired side at baseline). The analysis was done by one-way ANOVA followed Unadjusted Least Significant Difference (ULSD) post hoc test. Values are mean \pm SEM, n=9. p*<0.05 and p**<0.01 as compared to saline. #p<0.05 as compared to buprenorphine (0.3 mg/kg).....87

Chapter 5.....91

Figure 5.1 The mouse FST set-up.....95

Figure 5.2	The Mouse Plus Maze apparatus used.....	97
Figure 5.3	The light-dark box apparatus.	98
Figure 5.4	Effects of fluoxetine (10 and 20 mg/kg) in adult male CD1 mice in the forced swim test. Data are expressed as mean \pm SEM (n=10 per group) counts of swimming, immobility and climbing behaviours during the last 4-min of a 6 min swim test period. *p< 0.05, **p< 0.01 as compared to saline. #p< 0.05, ##p< 0.01 as compared to fluoxetine (10 mg/kg).....	104
Figure 5.5	Effects of buprenorphine (Bup 1mg/kg) and naltrexone (NTX 1mg/ kg), alone or in combination, in adult male CD1 mice in the forced swim test. The SSRI fluoxetine (20 mg/kg) was administered as a positive control. (A) All compounds under test produced antidepressant-like effects in the forced swim test. Data are expressed as mean \pm SEM (n=10 per group) of time spent swimming, climbing and immobile during the last 4 min of a 6 min swim test. * p< 0.05, ** p< 0.01, ***p< 0.001 compared to saline.....	106
Figure 5.6	Effects of buprenorphine (Bup 1mg/kg) and CCAM (3mg/kg), alone or in combination, in adult male CD1 mice in the forced swim test. The SSRI fluoxetine (20 mg/kg) was administered as a positive control. Data are expressed as mean \pm SEM (n=10 per group) counts of swimming, immobility and climbing behaviours during the last 4- min of a 6 min swim test period. **p< 0.01and ***p< 0.001 compared to saline. CCAM was administered 24 hr before injecting Bup.....	106

Figure 5.7 Effects of buprenorphine (Bup 1 mg/kg) and naltrexone (NTX 1 mg/kg), alone or in combination, in adult male CD1 mice in the novelty induced hypophagia task (novel cage 300 lux). The latency to drink milk in both the home and novel cage environments is shown. The SSRI fluoxetine (20 mg/kg) was administered as a positive control and the selective κ -antagonist norBNI (10 mg/kg) shown for comparison. All values are the mean \pm SEM. (n=10 per group). * p < 0.05, ** p < 0.01 and *** p < 0.001 compared to saline. ^^ p < 0.01 compared to buprenorphine alone. # p < 0.05,### p < 0.001 for comparison between groups.....107

Figure 5.8 Effects of buprenorphine (Bup 1 mg/kg) and naltrexone (NTX 1 mg/kg), alone or in combination, in the mouse novelty induced hypophagia task. The latency to drink milk in both the home and novel cage environments is shown (n=9 per group). (A) The SSRI fluoxetine (20 mg/kg) was administered as a positive control in the new lighting condition (500 lux). (B) The irreversible μ -antagonist CCAM (3 mg/kg) blocks the effects of buprenorphine (1 mg/kg) on latency to drink in the home cage, but not in the novel cage (n=9 per group). All values are the mean \pm SEM. * p < 0.05, ** p < 0.01 and *** p < 0.001 compared to saline. ^^ p < 0.01 compared to buprenorphine alone. ### p < 0.001 for comparison between groups.....108

Figure 5.9 Effects of diazepam (1 and 2 mg/kg) in adult male CD1 mice in the elevated plus maze. The time spent in open arm (A), the number of entries into the open arm (B), total locomotion (C) time spent in the closed arm (D)number of entries in the closed arm (E) distance travelled in open arm

(F) was recorded. Each column represents the mean \pm SEM (n= 9-10 per group). *p<.05 compared to saline by one-way ANOVA.....110

Figure 5.10 Effects of buprenorphine (Bup 1 mg/kg), naltrexone (NTX 1mg/kg), alone or in combination and diazepam 2 mg/kg in the elevated plus maze. (A) The time spent in open arm (B) the number of entries into the open arms (C) distance travelled in the open arm (D) total locomotion (E) the number of entries into the closed arms (F) distance travelled in the open arm (F) was recorded. Each column represents the mean \pm SEM of 10 adult male CD1 mice. *p<0.05 as compared to saline. Analysis was done by one-way ANOVA.....111

Figure 5.11 Effects of buprenorphine (Bup1 mg/kg) and naltrexone (NTX 1 mg/kg), alone or in combination, in the light-dark box (LDB) (A–C). The benzodiazepine diazepam (2 mg/kg) was included as a positive control. The time spent in the light box (A), in the dark box (B) and total ambulation (C) in the LDB are shown (n=18 per group). All values are the mean \pm SEM. *p< 0.05 compared to saline.....113

Figure 5.12 (A) Behaviour in the forced swim test for adult CD-1 male mice treated with BU10119 (1mg/kg), buprenorphine/naltrexone (Bup/NTX) (1mg/kg) combination and fluoxetine (20 mg/kg). All values are the mean \pm SEM (n=10 per group).***p <0.001 as compared to saline. The analysis was done by one-way ANOVA. (B) Effects of BU1019 (1mg/kg) and buprenorphine/naltrexone (1 mg/kg) combination in the mouse novelty induced hypophagia task. The SSRI fluoxetine (20 mg/kg) was administered as a positive control and the selective κ -antagonist norBNI (10

mg/kg) shown for comparison. All values are the mean \pm SEM (n=10 per group). ***p< 0.001 compared to saline. ###p< 0.001 for comparison between groups.....114

Figure 5.13 Effects of buprenorphine/naltrexone (Bup/NTX) (1 mg/kg) combination, BU10119 1mg/kg and diazepam 2 mg/kg in the elevated plus maze. (A) The time spent in open arm (B) the number of entries into the open arms (C) distance travelled in the open arm (D) total locomotion (E) the number of entries into the closed arms (F) distance travelled in the open arm (F) was recorded. Each column represents the mean \pm SEM of 10 adult CD1 mice. *p<0.05 and ** p<0.01 as compared to saline. The analysis was done by one-way ANOVA.....116

Figure 5.14 Effects of buprenorphine/naltrexone (Bup/NTX) (1 mg/kg) combination, BU10119 1mg/kg and diazepam 2 mg/kg in the elevated plus maze. (A) The time spent in open arm (B) the number of entries into the open arms (C) distance travelled in the open arm (D) total locomotion (E) the number of entries into the closed arms (F) distance travelled in the open arm (F) was recorded. Each column represents the mean \pm SEM of 10 adult CD1 mice. *p<0.05 and ** p<0.01 as compared to saline. The analysis was done by one-way ANOVA.....117

Chapter 6100

Figure 6.1 Time-line of the warm water tail-withdrawal experimental design, illustrating the time points of daily restraint, drug treatment and latency measurements for assessing stress-induced analgesia.....130

Figure 6.2	(A) one day and (B) 3 days time-line of the restraint stress protocol used. The time points of daily restraint, blood sampling and behavioural testing when assessing anxiety and depression related behaviour.131
Table 6.1	Gene-specific forward and reverse primers for GOI. Forward and reverse primers sequences were derived Basic Local Alignment Search Tool (BLAST) analysis to confirm the presence of the correct amplicon and expected amplicon size (in base pairs). Primers were used for both one-step RT-PCR and real-time RT-PCR.....134
Table 6.2	Conditions for one-step reverse transcription PCR amplification.....134
Figure 6.3	Effect of 1 day (A) and three day (B) repeated restraint stress (09:00-11:00) on plasma corticosterone of CD1 male mice. All blood samples were taken from 11:00-13:00 h. Results are expressed as mean \pm SEM, n=8. ***p<0.001 as compared to control. ###p<0.001 as compared to baseline stress group. Analysis done repeated measures mixed model analysis.....139
Figure 6.4	Effect of three-day restraint stress (09:00-11:00) and buprenorphine/naltrexone 1 mg/kg (Bup/NTX), BU10119 (1 mg/kg) and norBNI (10 mg/kg) on plasma corticosterone of adult male CD1 mice. norBNI was given once and 24 h before the first restraint stress session. All blood samples were taken from 11:00-13:00 h. Results are expressed as mean \pm SEM, n=8. **p<0.01, ***p<0.001

as compared to non-stressed saline. ##<0.001 comparison between groups. Analysis done repeated measures mixed model analysis.....140

Figure 6.5 A) Effect of 1 day and 3 day restraint stress (09:00-11:00) on stress-induced analgesia in CD1 male mice. (B) Baseline latency on day 3. Results are expressed as mean \pm SEM, n=4. ***p<0.001 as compared to non-stressed controls. Analysis done repeated measures mixed model analysis.....141

Figure 6.6 Effect of one day and three-day restraint stress (9-11am) on stress-induced analgesia in CD1 male mice. All drug treatments tested blocked stress-induced analgesia. Results are expressed as mean \pm SEM, n=6. ***p<0.001 as compared all groups. Analysis done repeated measures mixed model analysis. RS (Restraint stress).....142

Figure 6.7 Effects of acute restraint stress on behaviour in the elevated plus maze. The time spent in open arm (A), the number of entries into the open arm (B), time spent in the closed arm (C), number of entries in the closed arm (D), distance travelled in open arm (E) and total locomotion (F) was recorded. Each column represents the mean \pm SEM of 10 adult CD1 mice. Analysis was done by unpaired t-test.....144

Figure 6.8 Effects of 3 days repeated restraint stress on behaviour in the elevated plus maze. The time spent in open arm (A), the number of entries into the open arm (B), time spent in the closed arm (C), number of entries in the closed arm (D), distance travelled in open arm (E) and total

locomotion (F) was recorded. Each column represents the mean \pm SEM of 20 adult CD1 mice. * $p < 0.05$ as compared to non-stressed by unpaired t-test.....145

Figure 6.9 Effect of 1 day (A) and 3 days (B) restraint stress on behaviour in the FST in CD1 male mice. Time spent swimming and immobile were recorded in the last 4 minutes of a 6 minute test. Results are expressed as mean \pm SEM, $n=10$. Analysis was done by unpaired t-tests.....146

Figure 6.10 Baseline preference for bottle position in sucrose preference test for the front and back bottle (A) and total consumption as body weight % (B) in adult CD1 male mice. Preference was measured over a 12h test period (7pm-7am). Results are expressed as mean \pm SEM, $n=8$. Analysis was done by one way ANOVA.....147

Figure 6.11 Preliminary study to show effects of sucrose concentration on sucrose preference in adult CD-1 male mice. Preference for 1, 2.5 and 5% sucrose solution (A), total consumption of both sucrose and water (B) and sucrose consumption (C) were measured over a 12h test period (7pm-7am). Results are expressed as mean \pm SEM, $n=6-8$ /group. * $p < 0.05$, ** $p < 0.01$, *** $p < 0.001$ as compared to water presence. ## $p < 0.01$ as compared to 1% sucrose. & $p < 0.05$ as compared to 2.5% sucrose. Analysis was done by one-way ANOVA.148

Figure 6.12 Baseline preference for front and back water bottle (A) and total consumption as body weight % (B) in adult CD-1 male mice before 1 day restraint stress. Preference was measured over a 12h test period (19:00-07:00 h). Results

are expressed as mean \pm SEM, n=8. Analysis was done by unpaired t-test.....151

Figure 6.13 Effects of 1 day restraint stress on sucrose preference in adult CD-1 male mice. Preference for 5% sucrose solution (A), total consumption of both sucrose and water (B) and sucrose consumption (C) were measured over a 12h test period (19:00-07:00 h). Results are expressed as mean \pm SEM, n=8. ** p <0.01, *** p <0.001 as compared to non-stressed group. Analysis was done by unpaired t-test.....152

Figure 6.14 Baseline preference for front and back water bottle (A) and total consumption as body weight % (B) in adult CD-1 male mice. Preference was measured over a 12h test period (19:00-07:00 h). Results are expressed as mean \pm SEM, n=8. ** p <0.01 as compared to non-stressed group. Analysis was done by unpaired t-test.....153

Figure 6.15 Effects of 3 days restraint stress on sucrose preference test in adult CD-1 male mice. Preference for 5% sucrose solution (A), total consumption of both sucrose and water (B) and sucrose consumption (C) were measured over a 12h test period (19:00-07:00 h). Results are expressed as mean \pm SEM, n=8. Analysis was done by unpaired t-test.....154

Figure 6.16 Expression of kappa-receptor (k-receptor), prodynorphin (Pdyn) and corticotropin-releasing hormone receptor1 (CRHR1) mRNAs in adult CD-1 male mice in prefrontal cortex (PFC), nucleus accumbens NAc (A) hippocampus (Hip) and amygdala (Amy) (B). One-step RT-PCR with

gene specific primers.....155

Figure 6.17 Quantitative real-time RT-PCR amplification and melting points using 18s rRNA (A), κ -receptor (B), Pdyn (C) and CRHR1 (D) primers in vehicle non-stressed adult CD-1 male mice in PFC tissue. Amplification curves show increasing fluorescence on x-axis and PCR cycle number over 40 cycles of PCR amplification. Melting curves show $\Delta f/dt$ on x-axis and decreasing temperature (95-60°C).....156

Figure 6.18 Relative fold changes of κ -receptor, Pdyn and CRHR1 gene expression in repeated 3 day restraint stress adult CD-1 male mice in PFC (A), NAc (B), Hip (C) and Amy (D). Gene changes are relative to non-stressed control group and normalized to housekeeper gene (18s rRNA). Results are expressed as mean \pm SEM, n=3. Analysis was done by one-way ANOVA.....157

Chapter 7.....162

Figure 7.1 κ -receptor mediated signal transduction pathways. Activation by κ -receptor can result in activation of several kinase cascades. Arrows refer to activation steps, T lines refer to blockers or inhibition of function. Abbreviations are as follows: α G-protein alpha subunit, arrestin phosphorylation independent GPCR scaffold, $\beta\gamma$ G-protein beta-gamma subunit, cAMP cyclic adenosine monophosphate, ERK 1/2 extra-cellular signal regulated kinase, GRK3 G-protein coupled receptor kinase 3, JMR JNK Modulated Regulator, JNK c-Jun N-terminal Kinase, p38 p38 MAPK, P phosphorylation, pCREB phospho-cyclic AMP response element binding protein, PI3K

	phosphoinositol 3-kinase, PKCζ protein kinase C zeta, PTX pertussis toxin, Src short for sarcoma, member of the src family tyrosine kinases, zif268 transcription factor, also called Egr-1. (Reference: Bruchas and Chavkin, 2010).....	165
Figure 7.2	Efficacy of JNK activation correlates with duration of action. Quantification of pJNK-ir from Western blots was plotted as a function of the natural log of duration of antagonism for each compound. Natural log was used to transform the x values because the recovery of response after receptor inactivation follows the asymptotic kinetics of receptor expression approach to equilibrium. (Reference: Melief et al., 2011).....	166
Appendix		217
Table 1	An example of scoring sheet for assessing animals stat during restraint stress.(Adopted from Lloyd and Wolfensohn, 1999).....	218
Figure 1	Effect of 3 days restraint stress on daily bodyweight of adult CD-1 male mice. Results are expressed as mean ± SEM, n=8/group. **p<0.01 ***p<0.001 (repeated measures mixed model analysis).....	219

Acknowledgments

This thesis is dedicated to my parents, family and my uncle Abdulhakeem Almatroudi. A special thanks to my wife, Manal, for her patience, care, love and support throughout my study and life. A second special thanks to my son Mohammed who had to leave us and go back to Saudi Arabia to continue his study at the age of 16 and for depending on himself and his patience and love to his family during the last 4 years .

I would like to express my deepest thanks and gratitude to my supervisors, Drs Sarah Bailey, Chris Bailey and Steve Husbands, for their excellent guidance, encouragement and patience during the course of my study and during the writing of this thesis.

I would like thank my lab mates: Robin, Jo, Jess, Ben for help in qPCR and Annelisa for her helps and support and training during my study; all the staff at 4s Annex: Martin, Lesley, Jane, Jean, and Al for their help and support during my research.

I would like to thank my Saudi Arabian government and Saudi Arabian cultural bureau in London for their help, support and funding me during my studies.

Abstract

Opiates have been used historically for the treatment of depression. Renewed interest in the use of opiates as antidepressants has focused on the development of kappa opioid receptor (κ -receptor) antagonists. In this thesis I have tested the hypothesis that buprenorphine/naltrexone combination has antidepressant efficacy. Buprenorphine acts as a partial mu opioid receptor (μ -receptor) agonist and a κ -receptor antagonist. By combining buprenorphine with the non-selective opioid receptor antagonist naltrexone, the idea was that the activation of μ -receptors would be reduced and the κ -antagonist properties enhanced. First, the appropriate dose of the combination that would act as a short acting κ -receptor antagonist was investigated in the mouse-tail withdrawal test. A dose of BU10119, a novel compound derived from buprenorphine, with pharmacology resembling buprenorphine/naltrexone combination was also investigated. It was established that a combination dose of buprenorphine (1 mg/kg, i.p.) with naltrexone (1 mg/kg, i.p.) functioned as a short acting κ -antagonist in the mouse-tail withdrawal test and BU10119 (1 mg/kg, i.p.) is a κ -antagonist with a rapid onset and a duration of action not more than 24 hours. Furthermore, these doses of the buprenorphine/naltrexone and BU10119 were neither rewarding nor aversive in the conditioned place preference paradigm, and were without significant locomotor effects. Systemic co-administration of buprenorphine/ naltrexone (1 mg/kg, i.p.) and BU10119 in adult CD-1 male mice produced an antidepressant-like response in both the forced swim test and novelty induced hypophagia task. Behaviours in the elevated plus maze and light dark box were not significantly altered by either treatment.

Moreover, pretreatment with buprenorphine/naltrexone and BU10119 blocked stress- induced analgesia in adult male CD1 mice. However, they were not capable of blocking restraint stress-induced elevation of corticosterone levels. Gene expression of κ -receptor, prodynorphin and Corticotropin-Releasing Hormone Receptor 1 were not significantly altered by restraint stress or κ -receptor antagonist treatment in prefrontal cortex, nucleus accumbens, hippocampus and amygdala. I propose that the combination of buprenorphine with naltrexone and BU10119, both represent a novel approaches to the treatment of depression.

Abbreviations

δ-receptor	delta receptors
ORL-1 and NOP- receptor	nociceptin receptor
κ-receptor	kappa receptors
Amygdala	Amy
Ventral tegmental area	VTA
Hippocampus	Hip
Nucleus accumbens	NAc
Hypothalamus	HL
Locus coeruleus	LC
Substantia nigra	SN
Dorsal raphe nucleus	DRN
5-hydroxytryptamine	5-HT
Noradrenaline	NA
Dopamine	DA
Central nervous system	CNS
Tricyclic antidepressants	TCAs
Monoamine oxidase inhibitors	MAOIs
Selective serotonin reuptake inhibitors	SSRIs
Serotonin–noradrenaline reuptake inhibitor	SNRIs
Forced-swim test	FST
Medial prefrontal cortex	mPFC
Elevated plus maze	EPM
norbinaltorphimine	norBNI
(3R)-7-hydroxy-N-((1S)-1-[[[(3R,4R)-4-(3-hydroxyphenyl)-3,4-dimethyl-1-piperidinyl]-methyl]-2-ethylpropyl)-1,2,3,4-tetrahydro-3-isoquinolinecarboxamide	JDTic
5'-guanidinonaltrindole trifluoroacetic acid	GNTI
5'-acetamidinoethylnaltrindole	ANTI
Buprenorphine	Bup
Naltrexone	NTX
Clocinnamox	CCAM
Percentage maximum possible effect	%MPE
Unadjusted Least Significant Difference	ULSD
Mean ± standard error of the mean	SEM
Conditioned place preference	CPP
Novelty induced hypophagia	NIH
Novelty suppressed feeding	NSF
Light-dark box test	LDB
Stress-induced analgesia	SIA
Enzyme-linked immunosorbent assay	ELISA
Sucrose preference test	SPT
Reverse transcription PCR	RT-PCR
threshold cycle	CT
genes of interest	GOI
hypothalamus-pituitary-adrenal	HPA
c-Jun N-terminal kinase	JNK

Chapter 1

General introduction

1. Introduction

1.1. Opioid receptors

Opioid receptors were discovered in 1973 using opioid radioligand binding assays (Pert and Snyder, 1973a; Pert and Snyder, 1973b). It has been discovered that the endogenous opioid system is composed of four families of neuropeptides (endorphins, enkephalins, dynorphins and orphanin FQ/nociceptin) and four receptor subtypes which are called μ -receptor (mu receptors), δ -receptor (delta receptors), NOP-receptor (nociceptin receptor), which also called ORL-1, and κ -receptor (kappa receptors) (Pert and Snyder, 1973a; Terenius, 1973; Martin, 1979; Corbett et al., 2006; Koneru et al., 2009). In general, enkephalins interact with the δ -receptor, dynorphins interact with the κ -receptor, endorphins bind to both μ - and δ -receptors. Also, orphanin FQ/nociceptin interact with the ORL-1 receptors (Corbett et al., 2006; Koneru et al., 2009) (Figure 1.1). The endogenous opioid peptides play an important role in relieving pain by binding to the four primary opioid receptor. However, countenuse activation of μ -receptor causes euphoria, tolerance and physical dependence (Corbett et al., 2006; Koneru et al., 2009).

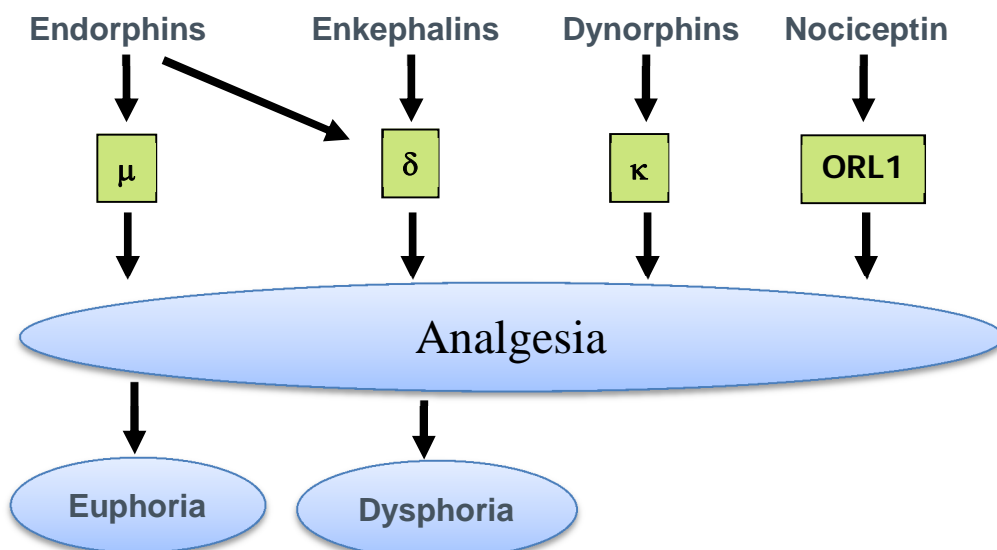

Figure 1.1. illustration diagram shows the site of action of endogenous opioid. (Adapted by permission from S.Bailey).

1.2. The kappa opioid receptors signalling pathway (κ -receptor)

The κ -receptors are seven transmembrane G-protein coupled receptors (GPCRs) that couple to heterotrimeric Gai/o proteins (Kieffer, 1995; Wu et al., 2012). Moreover, κ -receptor (Figure 1.2) was shown to have seven transmembrane domains in the core α -helices, which is connected by three extracellular loops (ECL1, ECL2, ECL3) and three intracellular loops (ICL1, ICL2, ICL3) (Wu et al., 2012). The κ -receptors have been cloned from the human (Simonin et al., 1995; Mansson et al., 1994), rat (Chen et al., 1993; Nishi et al., 1993; Meng et al., 1993), mouse (Yasuda et al., 1993; Nishi et al., 1994) and guinea pig (Xie et al., 1994). They have a high affinity for the endogenous neuropeptide dynorphins A and a variety of selective synthetic agonists and antagonists have been developed for the κ -receptors (Chavkin et al., 1982) (Table 1.1). The κ -receptors was originally studied for its involvement in the mediation of pain (Pasternak, 1980). However, the dysphoric side effects of κ -receptors agonists, have limited the ability of these compounds to be developed as therapeutic agents (Pfeifer et al., 1986; Bruchas et al., 2007). More recently, there has been growing interest in selective κ -receptors agents for their possible role on mood and reward.

Dynorphins are endogenous opioid peptides that are derived from prodynorphin, which include dynorphin A, dynorphin B, and big dynorphin (Schwarzer, 2009). Dynorphins bind and exert their effects through κ -receptors (Chavkin et al., 1982). Activation of κ -receptors causes coupling to the pertussis toxin-sensitive heterotrimeric Gai/o subunit that in turn inhibits adenylyl cyclase and cyclic adenosine monophosphate (cAMP) (Figure 1.3 and Table 1.2) (Schoffelmeer et al., 1988; Lawrence and Bidlack, 1993; Konkoy and Childers, 1993). Also, the G beta(β) /gamma(γ) subunits of the trimeric G protein directly block calcium channels (Tallent, 1994) and open K⁺ channels (Henry et al., 1995) which produces an inhibitory effect in neurons (Schoffelmeer et al., 1988). The evidence for κ -receptors positively coupling to potassium channels and negatively affecting calcium channels

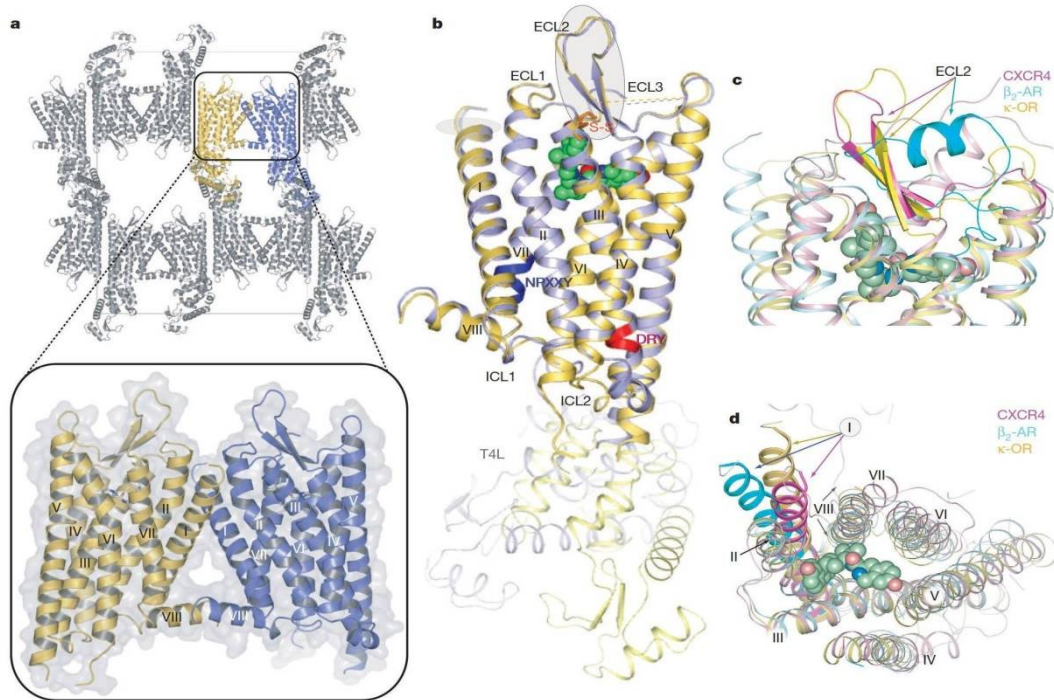

Figure 1.2. Crystal packing and overview of the human κ -receptor structure in complex with JD(Tic), and comparison with the inactive CXCR4 and β 2-AR structures. a, κ -receptor -T4L crystal packing. The parallel dimer in one asymmetric unit is highlighted by the insert. b, Overall architecture of κ -receptor -T4L in complex with JD(Tic). The A molecule (yellow) and B molecule (blue) from one asymmetric unit are aligned through the receptor part. The DRY and NPXXY motifs are highlighted in red and blue, respectively. JD(Tic) is shown in a green sphere representation and the disulphide bond is coloured orange. c, d, Side (c) and extracellular (d) views of a structural alignment of the human κ -receptor (yellow); CXCR4 (PDB accession 3ODU; magenta) and β 2-AR (PDB accession 2RH1; cyan). The graphics were created by PyMOL. (adopted from Wu et al., 2012).

has been confirmed in several cell types ranging from neurons of the hippocampus to the dorsal root ganglia, suggesting that these ion channel effectors are highly targets of κ -receptors activation (Grudt and Williams 1995). Also, it was suggest that activation of the κ -receptors causes intracellular calcium mobilisation via the inositol trisphosphate pathway (Spencer et al., 1997), which can lead to an enhanced hyperpolarisation-activated current in the rat nucleus raphe magnus (Pan, 2003). In vivo experments, it has been reporetd that activation κ -receptors cause excitatory actions in the central nervous system (Johnson et al., 2008; Mc Dermott et

Table 1.1. κ -receptor agonists and their binding affinities μ , κ and δ (values extracted from IUPHAR receptor database; accessed 06/12/2016)

Endogenous peptide agonists	Synthetic agonist Synthetic	Synthetic antagonist Synthetic	Affinity of agonist ligand to κ -receptors (pKi)	Selectivity	Activity
Dynorphin A			8.3 – 10.8		Full agonist
Dynorphin B			8.1 – 9.9		Full agonist
	Ethylketocyclazocine		10	κ - δ	Full agonist
	Enadoline		9.6	κ	Full agonist
	U69593		9.5	κ	Full agonist
	U50,488		7.8-9.7	κ	Agonist
	Salvinorin A		7.8-8.7	κ	Full agonist
		JDTic	9.5 – 11.2	κ	Antagonist
		norBNI	9.6 – 10.7	κ	Antagonist
		LY2456302	9.1	κ	Antagonist
		naltrexone	8.4 – 9.4	κ	Antagonist
		naloxone	7.6 – 8.6	κ	Antagonist
		zyklophin	7.5	κ	Antagonist

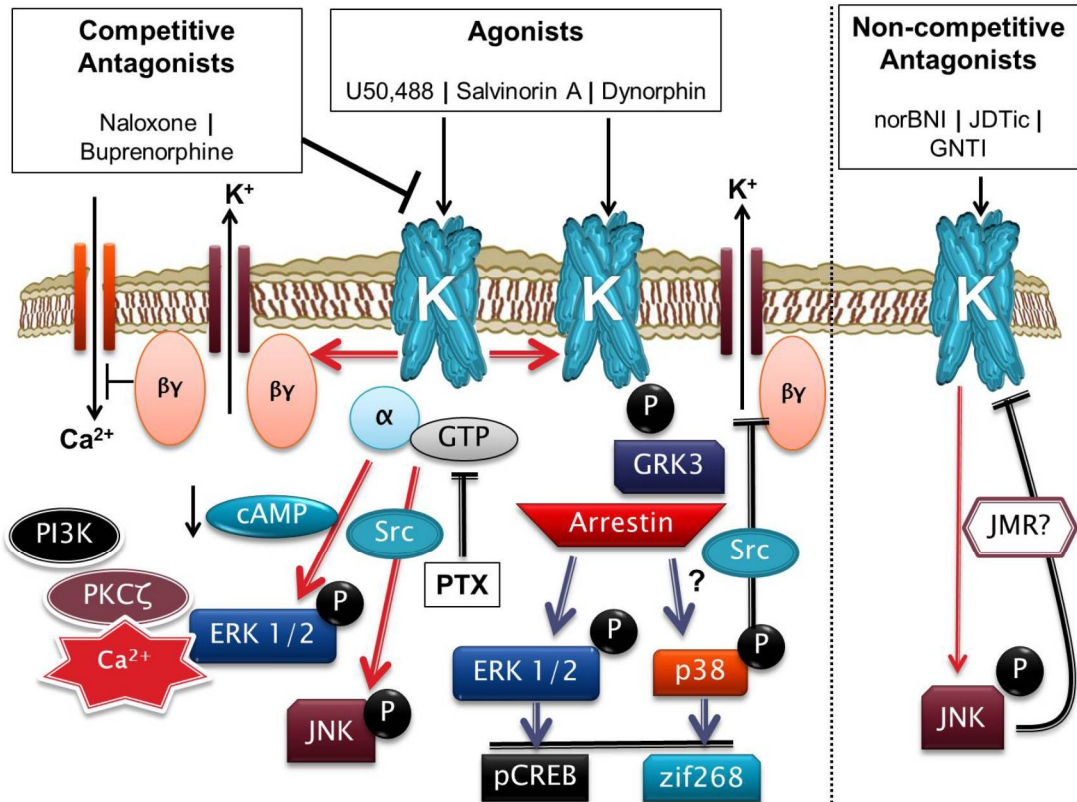

Figure 1.3. K-receptor-mediated signal transduction. Cartoon depicting the current status of the KOR signal transduction pathways. Receptor activation by a variety of K-receptor - selective ligands can result in activation of several kinase cascades. Arrows refer to activation steps, T lines refer to blockers or inhibition of function. Abbreviations are as follows: αG-protein alpha-i subunit, arrestin phosphorylation dependent GPCR scaffold, βγ G-protein beta-gamma subunit, cAMP cyclic adenosine monophosphate, ERK 1/2 extra-cellular signal regulated kinase, GRK3 G protein coupled receptor kinase3, JMR JNK Modulated Regulator, JNK c-Jun N-terminal Kinase, p38 p38 MAPK, P phosphorylation, pCREB phospho-cyclic AMP response element binding protein, PI3K phosphoinositol 3-kinase, PKCζ protein kinase C zeta, PTX pertussis toxin, Src short for sarcoma, member of the src family tyrosine kinases, zif268 transcription factor, also called Egr-1. Adapted from Bruchas and Chavkin, 2010.

Table 1.2. Shows the characteristics of the cloned opioid receptors.

	μ	δ	κ_1
Gene family	7TM G-protein coupled	7TM G-protein coupled	7TM G-protein coupled
Gene organization	Intronic	Intronic	Intronic
Amino acid length	398	372	380
mRNA Size	10-16 kb	4.5 kb	5.2
Binding characteristics	DAMGO Morphine CTOP	DPDPE DSLET Naltrindole	US8488 DYNA(I-17) norBNI
Signal transduction	Coupled to inhibitory G protein ↓ cAMP	Coupled to inhibitory G protein ↓ cAMP	Coupled to inhibitory G protein ↓ cAMP
Number of glycosylation sites	5	2	2
mRNA distribution	Thalamus Striatum Locus coeruleus Nucleus of the solitary tract	Cortex Striatum Lateral reticular	Hypothalamus Nucleus accumbens Substantia nigra Ventral tegmental area Nucleus of the solitary tract

The cloned opioid receptors have similar binding properties to the receptors characterized in brain homogenates. Examples of two receptor agonists and an antagonist that binds to each of these cloned receptors is presented above. Anatomical areas listed are examples of regions demonstrating high levels of μ - δ or κ_1 -receptor mRNA expression. Abbreviations: 7TM, seven transmembrane; CTOP, D -Phe-Cys-Tyr- D -Trp-Orn-Thr-Pen-Thr, DAMGO, D -Ala²-MePhe⁴-Gly-ol⁵-enkephalin; DPDPE, D -Pen²- D -Pen⁵-enkephalin; DSLET, D -Ser²- D -Leu⁵-enkephalin; U58488, 3,4-dichloro-N-[2-(1-pyrrolidinyl)-cyclohexyllbenzene acetamide; DYNA(I-17), dynorphina A(I-17); and norBNI, norbinaltorphimine. (Adapted from Mansour et al., 1995).

al., 2011; Rocha et al., 1997). Dual coupling to excitatory and inhibitory G-proteins (Gs and Gi) has been documented for all of the opioid receptor systems, and it has been proposed by these studies that κ -receptors under some circumstances couple to can stimulatory G-proteins (Crain and Shen 1990).

1.2.1. κ -receptors and mitogen-activated protein kinase (MAPK) cascade activation

The mitogen-activated protein kinases (MAPKs) are the family of kinases that transduce signals from the cell membrane to the nucleus in response to a wide range of stimuli, including stress (Seger and Krebs, 1995; Chang and Karin, 2001; Werlen et al., 2003). MAPK pathway is activated by trophic and growth factor receptors and has been identified as a critical mediator that regulate diverse cellular programs including: apoptosis, differentiation, embryogenesis, cell proliferation, transcription factor regulation, protein-protein interactions and ion channel phosphorylation (McClellan et al., 2007; Raman et al., 2007; Werlen et al., 2003). MAPKs consist of three family members: the extracellular signal-regulated kinase (ERK); the c-Jun NH₂-terminal kinase (JNK); and the p38- MAPK (Seger and Krebs, 1995; Tibbles and Woodgett, 1999; Widmann et al., 1999; Davis, 2000; Chang and Karin, 2001; Johnson and Lapadat, 2002). κ -receptor agonists have been shown to activate all three MAPK family members including the extracellular signal-regulated kinase (ERK), the stress kinase p38 and the stress kinase c-Jun N-terminal kinase (JNK) (Bruchas et al., 2007a; Bruchas et al., 2007; Belcheva et al., 2005) (Figure 1.3).

1.2.2. κ -receptor and ERK 1/2 MAPK activation

The extracellular signal-regulated kinase (ERK) family has its own subfamilies: ERK1 and ERK2 (Seger and Krebs, 1995; Tibbles and Woodgett, 1999). Acute activation of κ , μ and δ receptors have been reported to cause ERK 1/2 phosphorylation in astrocyte cultures via different signalling pathways (Belcheva et al., 2005; Belcheva et al., 1998) (Figure 1.2). Moreover, κ -receptors activation has been reported to direct embryonic

stem cell fate decisions (Kim et al., 2006) and to stimulate proliferation of astrocytes (McLennan et al. 2008). Moreover, it has also been reported that κ -receptor-induced ERK 1/2 phosphorylation occurs in a multi-phase manner (Gesty-Palmer et al., 2006), an arrestin-independent early phase (Arrestins are a small family of proteins important for regulating signal transduction at GPCRs) and an arrestin-dependent late phase in astrocytes (McLennan et al., 2008). It has been reported that repeated swim-stress, a test that induce a sufficient dynorphin release (McLaughlin et al., 2003), caused GRK3-independent (G-protein-coupled receptor kinase 3), ERK 1/2 and pCREB phosphorylation in the nucleus accumbens (NAc) of mice (Bruchas et al., 2008). They reported that these effects are mainly due to the κ -receptor activation and it was blocked by the κ -receptor antagonist, norbinaltorphimine (norBNI) and absent in κ -receptor knockout mice.

1.2.3. κ -receptor and p38 MAPK activation

P38 mitogen-activated protein kinases are a class of MAPK. P38-MAPK is activated in response to a variety of cellular and environmental stresses such as ischemia, heat shock, DNA damage, inflammatory cytokines and UV irradiation ceramide (Seger and Krebs, 1995; Tibbles and Woodgett, 1999; Chang and Karin, 2001; Johnson and Lapadat, 2002). The p38-MAPKs were originally termed as mammalian homologues to the yeast protein Hog1 that sense osmolarity change (Han et al., 1994). In most cases, p38-MAPKs are simultaneously activated with JNKs (Werlen et al., 2003). At least four isoforms of p38-MAPK have been known: p38-MAPK α , p38-MAPK β , p38-MAPK δ , and p38-MAPK γ (Kyriakis and Avruch, 2001). κ -receptor-induced p38 MAPK phosphorylation has been confirmed in several systems in vivo including astrocytes, the spinal cord, GABAergic neurons in the NAc, the cortex and the hippocampus (Bruchas et al., 2006, 2007a; Xu et al., 2007). Moreover, it has been reported that the p38 MAPK pathway play a critical role in modulating chronic pain states (Watkins et al., 2001) and κ -receptor-induced p38 MAPK activation in astrocytes has been involved in cellular reorganisation after nerve injury (Xu et al., 2007). The activation of p38 MAPK by κ -receptor has been shown to require receptor

phosphorylation at serine 369 by GRK3 and subsequent arrestin3 recruitment in primary cultures and in vivo (Bruchas et al., 2006). It was reported by Bruchas et al (2006) that κ -receptor induced p38 requires GRK3/arrestin and that was in contrast with κ -receptor mediated ERK 1/2 phosphorylation, which has both arrestin-independent (Bruchas et al., 2006, 2008) and dependent phases (McLennan et al., 2008).

Bruchas et al (2007a) reported that the selective p38 inhibitor SB203580 was able to block κ -receptor agonist induced conditioned place aversion and stress-induced immobility after induction of p38 MAPK phosphorylation following behavioural stress in vivo, but the mechanisms whereby p38 mediates the κ -receptor dependent effects are not clear.

It has been reported that the potassium channel K (ir) V was shown to become tyrosine phosphorylated by a κ -receptor dependent p38 MAPK-induced Src activation (Clayton et al., 2009). They reported that κ -receptor activation caused phosphorylation of Y12-K(ir)3.1 and channel inhibition through a GRK3-, p38 MAPK- and Src-dependent mechanism. It was suggested that the decrease in the inward potassium current after κ -receptor activation may increase neuronal excitability and may contribute to κ -receptor mediated behavioural responses (Clayton et al., 2009). It was suggested that, p38 MAPK might cause a synaptic depression in some regions while increasing excitation in others. Moreover, it has been documented that p38 is involved in increasing serotonin reuptake through PP2A (phosphatase) and p38-dependent SERT modification (Zhu et al., 2005; Prasad et al., 2005), and κ -receptor activated p38 MAPK in the dorsal raphe nucleus, a serotonergic nucleus, has been suggested to be involved in the κ -receptor dysphoric behaviours effect (Bruchas et al., 2011; Land et al., 2009).

1.2.4. κ -receptor and JNK MAPK activation

JNKs are also known as stress-activated protein kinases; SAPKs, and the JNK stress pathways are involved in many different intracellular

signalling pathways that control a variety of cellular processes, including differentiation, cell growth, transformation, or apoptosis. The JNKs has its own subfamilies: (JNK1, JNK2, and JNK3) (Seger and Krebs, 1995; Tibbles and Woodgett, 1999; Davis, 2000; Chang and Karin, 2001; Johnson and Lapadat, 2002; Werlen et al., 2003). Song et al (2009) reported that the activation JNK causes phosphorylation of specific sites on the amino-terminal transactivation domain of c-Jun, a critical transcription factor in the AP-1 complex. It has been suggested that all arrestin isoforms have the capacity to scaffold JNK (McDonald et al., 2000). The κ -receptor agonists U69,593, U50,48 and Dynorphin B cause JNK phosphorylation (Kam et al., 2004; Bruchas et al., 2007b). It has been reported that U69,593 and U50,488 induced JNK phosphorylation are mediated through pertussis toxin-sensitive G α - activation (Kam et al., 2004; Bruchas et al., 2007b). Moreover, it has been shown that the κ -receptor -induced Src stimulation and GTPase Rac-dependent activation of focal adhesion kinases were critical for κ -receptor -mediated JNK activation in immune cell types (Kam et al., 2004). The identification of the isoform of JNK that κ -receptor activates remains unresolved. However, Melief et al (2011) using JNK knockout mice suggested that the JNK1 isoform mediates the κ -receptor effects.

1.3. κ -receptor anatomical localisation

K-receptors are widely expressed throughout the brain, spinal cord, and peripheral tissues. The expression of both κ -receptors and prodynorphin is high in brain regions that are involved in mood, cognitive, stress responses and reward such as the amygdala (Amy), ventral tegmental area (VTA), hippocampus (Hip), nucleus accumbens (NAc), hypothalamus (HL), locus coeruleus (LC), substantia nigra (SN), and dorsal raphe nucleus (DRN) in human and rodent brains (DePaoli et al., 1994; Kitchen et al., 1997; Lin et al., 2006; Mansour et al., 1994; Crowley and Kash, 2015) (Figure 1.4). It has been documented that the κ -receptors are also expressed at several levels of pain circuitry, including areas such as the dorsal root ganglia, dorsal spinal cord, rostral ventromedial medulla, periaqueductal gray, sensory thalamus (Mansour et al., 1988; Knoll et al., 2010; Winkler et al., 2006;

Neugebauer et al., 2004). Moreover, it has been suggested through receptor binding studies that the κ -receptor is composed of three subtypes named $\kappa 1$, $\kappa 2$, and $\kappa 3$ (Minami et al., 1993). However, only one cDNA clone for the κ -receptor has been documented (Simonin et al., 1995; Mansson et al., 1994). Also, it has been suggested that there is an interaction between κ and δ -receptors that cause $\kappa 2$ subtype pharmacology (Jordan and Devi, 1999).

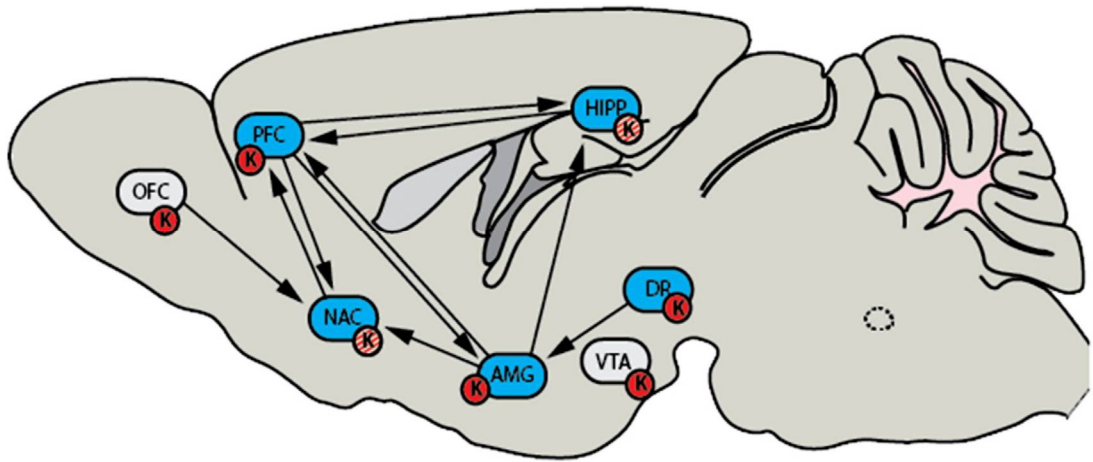

Figure 1.4 . K-receptors modulate the interactions between major circuits involved in stress responses, anxiety, and addiction. K-receptors are found in many key brain regions known to be involved in a variety of diseases, such as anxiety and addiction. It has been found that KORs do not only mediate aversive or anxiogenic responses (red circles); literature has shown that KORs (red and white circles) can also be reinforcing, such as in the nucleus accumbens. In addition, dynorphin knockout mice show increased fear conditioning. Key: orbital frontal cortex (OFC); prefrontal cortex (PFC); nucleus accumbens (NAC); amygdala and extended amygdala (AMG); hippocampus (HIPP); ventral tegmental area (VTA); dorsal raphe nucleus (DR); kappa opioid receptor (K). (Adopted from Crowley and Kash, 2015).

It has been reported that there is species differences between humans and guinea pigs expressing much higher levels of κ -receptors in brain than rats and mice (Table 1.3). Moreover, studies have showed that guinea pigs, but not rats nor mice, have a similar distribution of κ -receptor as humans, e.g., being abundant in cerebellum, layers V and VI of the cortex and in striosomes of the striatum (Quirion et al., 1987; Quirion and Pilapil, 1991).

Table 1.3. Relative proportions of the opioid receptors in several species

Species	μ	δ	κ
Human	22.7 (29%)	27.0 (34%)	29.2 (37%)
Guinea-pig	17.1 (25%)	17.7 (25%)	34.4 (50%)
Mouse	32.5 (25%)	81.0 (62%)	17.6 (13%)
Rat	52.5 (41%)	64.1 (50%)	12.6 (9%)
Pigeon	17.7 (14%)	12.4 (10%)	100.2 (76%)

Opioid receptor binding in the forebrains of several species as determined by Scatchard analysis. The upper number of each pair refers to fmol per mg tissue. μ receptors were labelled with [3H]-DAMGO, δ sites with [3H]-DPDPE and κ -receptors with [3H]-bremazocine in the presence of a 300-fold excess of unlabelled DAMGO and DPDPE. Given the total amount of opioid binding, the numbers beneath in parentheses are the relative abundance of these sites within brain tissue. The values reported here reflect the binding of human frontal cortex and forebrain tissue of the mouse rat, guinea-pig and pigeon (Source: Mansour et al., 1988).

1.4. Effects κ -receptors on neurotransmitter release

The majority of studies on dynorphin and κ -receptor interactions with monoamine systems have focused on dopamine, especially on the mesolimbic dopamine system. The mesolimbic dopamine system have been documented to plays an important role in motivational and reward behaviours. It consist of the nucleus accumbens (NAc; ventral striatum) and its dopaminergic input from the ventral tegmental area (VTA) (Di Charo and Bassareo, 2007; Ikemoto, 2010).

The principal neuron in the NAc is medium spiny projection neurons (MSNs), which make up approximately 90% of all neurons. Principal projection neurons contain γ -aminobutyric acid (GABA) as the primary neurotransmitter and a variety of neuropeptides, including, enkephalin, substance P and neurokinin B (Zahm and Heimer, 1988; Meredith et al., 1993). Moreover, dynorphin is expressed in MSNs of the NAc and the dorsal striatum. The GABAergic MSNs in the NAc, predominantly co-express dopamine D1 receptors and dynorphin, which directly project back to the VTA (Conrad and Pfaff, 1976; Phillipson, 1979). In addition, dynorphin, in the dorsal striatum, is highly expressed in D1 receptor-expressing neurons that project to the substantia nigra (Fisone et al., 2007; You et al., 1994). Moreover, in the dorsal and ventral striatum, MSNs have axon collaterals that can release dynorphin. κ -receptors are localised on the terminals and cell bodies of VTA DA neurons, which input onto the NAc (Shippenberg and Rea, 1997; Svingos et al., 1999) and can regulate local neurotransmitter such as DA, serotonin and glutamate release within NAc (Chefer et al., 2005; Schlosser et al., 1995; Spanagel et al., 1992; Svingos et al., 1999; Thompson et al., 2000; Hjelmstad and Fields, 2001; Hjelmstad and Fields, 2003) (Figure 1.5). Indeed, it has been reported that κ -receptor activation in the NAc region by dynorphin and κ -receptor agonists decreases dopamine release. In contrast, it has been shown that κ -receptor antagonist causes an increase in DA release (Spanagel et al., 1992; Maisonneuve et al., 1994). Moreover, it has been reported in vivo microdialysis studies that U50,488 infusion into the dorsal raphe, median raphe and NAc inhibits 5-HT release

in those sites, suggesting that that κ -receptor directly modulates 5-HT release at pre-synaptic terminals in target regions (Tao and Auerbach, 2002; Tao and Auerbach, 2005).

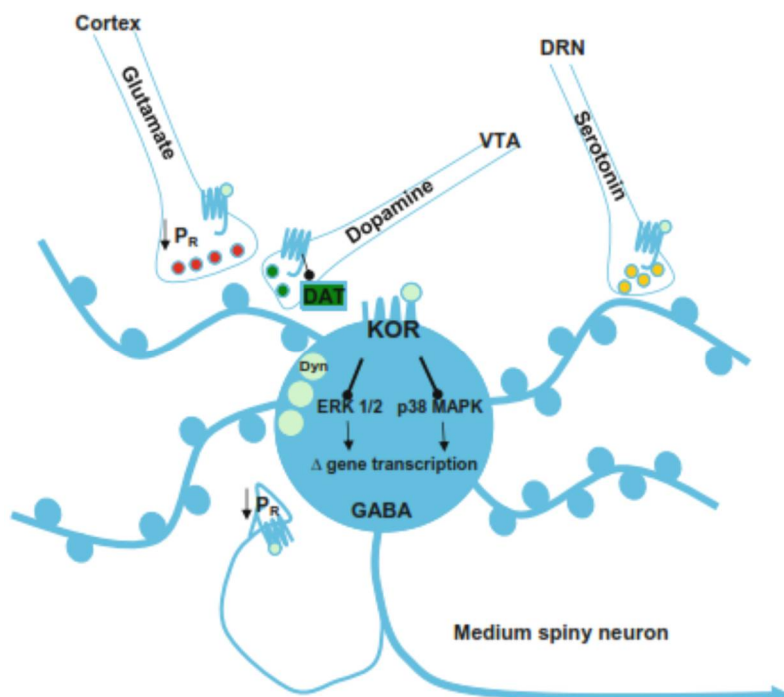

Figure 1.5. Summary of κ -receptor modulation and downstream signalling in NAc, Cartoon summary of the sites of κ -receptor modulation in a medium spiny neuron of the NAc and downstream effectors of κ -receptor activation. Following release of dynorphin (light green circles), κ -receptor (bright green squiggle) can inhibit the release of glutamate (red terminal), dopamine (green terminal), GABA (blue axon collateral), and serotonin (orange terminal). It has been shown that κ -receptor increases dopamine uptake transporter (DAT) function (dark green box) to inhibit dopamine release. Post-synaptically κ -receptor increases (line with ball at the end) ERK 1/2 and p38 MAPK activity through parallel pathways. Source: Pasternak, 2011.

Using radioligand binding assays and in vivo microdialysis Berger et al (2006) investigated the effects of κ -receptor activation on (noradrenaline) NA release in the forebrain. In this study, the effects of U50,488 on NA release from neocortical slices of rat and human were assessed using tritiated NA. In rats, the μ -receptor agonist DAMGO inhibited NA release in the neocortex, but neither κ nor δ -receptor agonists had any effect. However, in human neocortical slices, DAMGO had no effect on NA release, but κ and δ -receptor agonists were able to produce a small depression in NA release (Berger et al., 2006).

1.5. Depression

Depression is one of the most serious mental illness affecting 350 million people worldwide (WHO 2016a) and it can influence the ability of the patient to function at school, at work and in the family. Depression is defined in DSM-IV (American Psychiatric Association, 1994), as condition characterized by the presence of loss of pleasure or interest in usually pleasurable activities (anhedonia), together with an array of other features, including anergia, changes in sleep and appetite, sadness, and suicidal ideation. It is associated with decreased productivity in the workplace and an increased risk of absenteeism from work. Also in severe cases, a depressed patient may commit suicide. Each year, almost 800,000 people worldwide die because of suicide. It was estimated that almost 78% of suicide attempt were in patients affected by major depression (Broadhead et al., 1990; Holma et al., 2010; WHO 2016a). Depression is a debilitating recurrent psychiatric disorders and almost over three-quarters of all patients who recover from one attack of depression go on to one or more attacks in future (Keller, 2001). Many patients may suffer from chronic depression if not treated, lasting over 2 years in one-third of patients (Mental Health Policy Group, 2006). Depression is the fourth cause of disability worldwide and it exerts a huge economic cost (Mauskopf et al., 2009; Ustün et al., 2004) and by 2020 it's predicted that depression will become the second leading cause of disability worldwide (WHO 2016b). The prevalence of depression disorder

in population is not well determined. However, it has been reported that lifetime prevalence of depression in general populations is in the range of 10% to up to 15% (Lépine and Briley, 2011; Vos, 2012). Also, women are twice more likely to be diagnosed with depression than men (Kuehner, 2003).

Depression is characterized by a number of signs and symptoms such as feelings of sadness, loss of pleasure or interest in all or most activities during the day, loss of interest in sex, severe reduction or increase in appetite, insomnia or excessive sleeping, agitation or slowness of movement, fatigue or lack of energy, feelings of guilt or low self-worth, recurrent thoughts of death and urge to commit suicide and reduced ability to think or concentrate (American Psychiatric Association, 2013). Depending on severity and number of the sign and symptoms, a depressive attack can be categorised into mild, moderate, or severe (WHO 2016^{1a}) which are important for treating depression (Bennett and Torrance, 1996). Depressive disorders come in different forms such as major depression (unipolar depression), disruptive mood dysregulation disorder, postpartum depressive disorder, persistent depressive disorder (dysthymia), premenstrual dysphoric disorder and manic-depressive or bipolar disorder which is not predominant as other forms of depressive illnesses (American Psychiatric Association, 2013; Katon, 1987). Of these forms, major depression represents the classic condition and is characterised the patient losing his interest or pleasure in everyday activities, almost each day, and these symptoms and mood disturbance may last for at least 2 weeks in duration. These depressive symptoms may happen once, twice or several times in a lifetime. In persistent depressive disorder (dysthymia), these symptoms are chronic and less severe that do not disable the patient. However, it reduces the patient functionality and prevents him from feeling well. The mood disturbance in this form lasts for at least 2 years in adults or 1 year in children (American Psychiatric Association, 2013).

Patients diagnosed with depression also suffer from anxiety disorders and over half of patients with depression have a persistence chronic history of anxiety disorders (Kessler et al., 1996; Fava et al., 2000). This comorbidity is associated with an increase in severity and persistence of symptoms, for example, higher incidence of suicidality (Roy-Byrne et al., 2000). Anxiety and depression disorders are different, but patient with depression generally experience symptoms similar to those of an anxiety disorder, such as feeling tense, or restless, irritable, significant tension in muscles, easily to become fatigued and difficulty in sleeping and concentrating. The presence of three or more of these symptoms for most days over the previous six months is a sign of generalized anxiety. However, each disorder has its own causes and its own signs and symptoms (American Psychiatric Association, 2013).

1.6. The neurobiology of depression

Unfortunately, the exact underlying etiology of the biological mechanisms behind depression is still unclear (Cryan et al., 2002). Several overlapping mechanisms and factors may contribute to the development of these disorders, including alteration of brain chemistry, genes, gender and exogenous stressors such as, trauma and environmental factors (Charney and Manji, 2004; Caspi et al., 2003; Belmaker and Agam, 2008). However, the possible mechanisms that have been investigated include the monoamine hypothesis, stress and the hypothalamic-pituitary-adrenal axis and neurogenic mechanisms (Figure 1.6).

1.6.1. Monoamine hypothesis

The monoamine hypothesis has been the dominant hypothesis of depression for decades. It states that these disorders are accompanied by decreased monoamine transmission: in 5-hydroxytryptamine (5-HT), noradrenaline (NA) and dopamine (DA) (Nestler et al., 2002). DA and NA are synthesised from the precursor tyrosine. The monoamine serotonin (5-hydroxytryptamine or 5-HT) is synthesised from tryptophan, which is converted inside the nerve terminal to 5-hydroxytryptophan (5-HTP) by the

rate-limiting enzyme tryptophan hydroxylase (TPH). After the release of monoamines, they are able to bind to specific receptors on both presynaptic and postsynaptic terminal membranes. NA, it is able to bind to three families of adrenergic receptors: α_1 , α_2 and β . 5-HT bind to 7 main types of 5-HT receptors (1–7) (Barnes et al., 1999). Moreover, and DA is able to bind to D₁-like receptors that includes the D₁ dopamine receptor (D_{1DR}) and D_{5DR} or to D₂-like receptors that include the D_{2DR}, D_{3DR} and D_{4DR} (Missale et al., 1998; Neve et al., 2004). Reuptake of the monoamines into the presynaptic neuron by Na⁺/Cl⁻-dependent transporters terminate their action (Nelson, 1998).

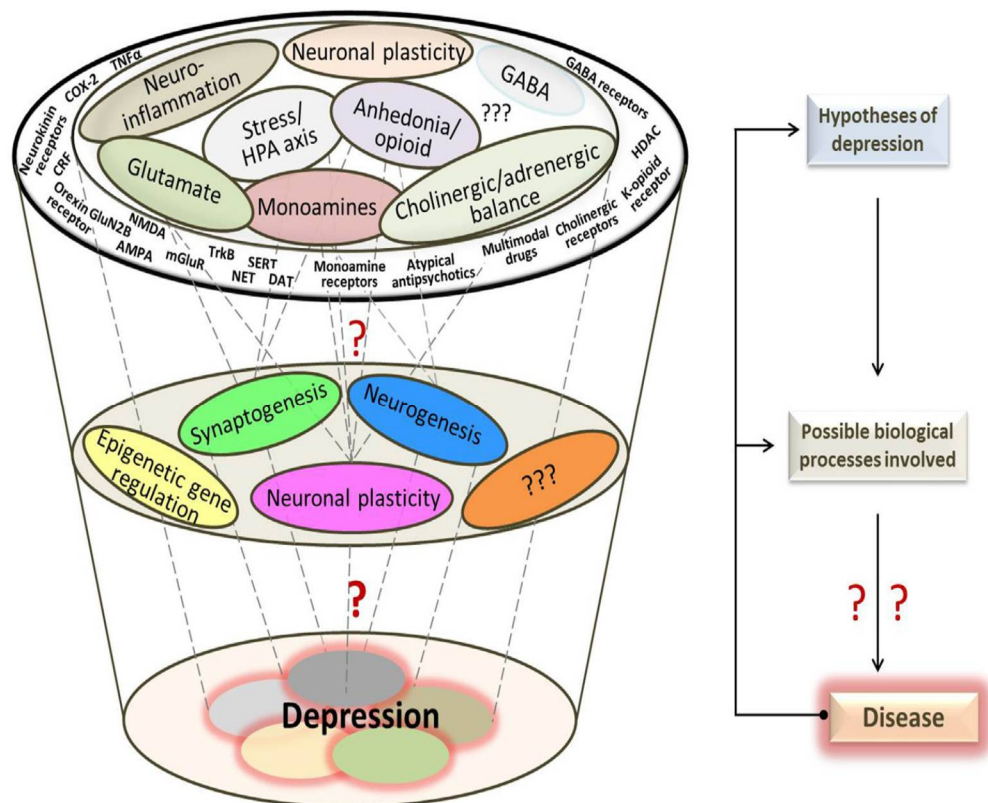

Figure 1.6. The possible current hypotheses of depression. In the top oval, the possible hypotheses of depression and their associated drug targets are listed. In the middle oval, the possible biological courses involved in the etiology of depression are shown (source Dale et al., 2015).

The development of monoamine hypothesis was by the chance finding that iproniazid, a drug intended for the treatment of tuberculosis, was able to elevate mood in depressed patients (Lopez-Munoz et al., 2009). The mechanism behind this was found to be the inhibition of the enzyme monoamine oxidase (Delay et al., 1952) which caused an increased in postsynaptic stimulation through increased neurotransmitter availability. Indeed, preclinical and clinical evidence suggests disturbances in 5-HT and NA neurotransmission in the central nervous system (CNS). For example, it was documented that a significant decrease in the levels of 5-hydroxyindoleacetic acid (a serotonin metabolite) and homovanillic acid (a dopamine metabolite) in the cerebrospinal fluid are noticed in patients with depression (Post et al., 1980; Lakshmi et al., 1992). Moreover, it was reported that serotonin levels were significantly lower in patients with major depressive disorders (Quan-Bui et al., 1984; Malison et al., 1998). In addition, depression was induced after treatment with an antihypertensive drug known as reserpine, which depletes both 5-HT and catecholamines (Goodwin et al., 1971), whereas treatment with parachlorophenylalanine, a drug that depletes central 5-HT by inhibiting TPH, blocks the beneficial effects of tricyclic antidepressants (TCAs) and monoamine oxidase inhibitors (MAOIs) (Shopsin et al., 1976; Shopsin et al., 1975). Also, it was reported that patients who have been treated successfully with NA reuptake inhibitor, suffer from relapse after the administration of a tyrosine hydroxylase inhibitor called α -methyl-para-tyrosine that causes catecholamine (DA and NA) depletion (Booij et al., 2003), although it does not induce depression in normal subjects. That's way, a huge efforts and research were made to produce a novel drugs that increases monoamine function through inhibiting 5-HT and NA transporters since the 1960s (Post et al., 1980; Lakshmi et al., 1992; Dale et al., 2015). Moreover, an increasing evidence in literature suggests an important role for DA signalling in different brain regions (Nieoullon and Coquerel, 2003; Nestler and Carlezon, 2006). Moreover, it has been reported that a reduction in mesolimbic dopamine circuit that consists, in part, of dopaminergic neurons of the VTA that project to the NAc, which is involved in responses to emotional and rewarding stimuli (Morgane

et al., 2005), is responsible for the loss of pleasure (anhedonia) (Schultz et al., 1997; Nestler and Carlezon, 2006).

The monoamine hypothesis is the most established mechanism of depression pathology. However, this hypothesis has unresolved issues. One of them is the temporal delay between the increase of monoamines at the synapse caused by antidepressant administration, which occur within hours, and the onset of therapeutic improvements in patients that take up to 4 weeks to developed (Baldessarini, 1989). Moreover, an effort to induce depression on healthy volunteers through acute tryptophan depletion, which transiently lowers 5-HT brain activity through dietary restriction, has been shown to have no effect (Ruhe et al., 2007). That is way it is difficult to explain the whole mechanism of antidepressant action by the acute increase in monoamines, which does not provide a full understanding of the pathophysiology of depression. However, researcher has moved beyond the measurement of monoamine levels, but they focus on molecular components of monoaminergic signalling pathways that include receptors, enzymes and transporters.

1.6.1.1. Serotonin and depression

The serotonergic pathways start from the brainstem raphe nuclei, which are found lying in or lateral to the midline regions of the pons and upper brainstem (Jacobs et al., 1992). The raphe nuclei are divided into the dorsal raphe nucleus (DRN), the median raphe nucleus (MRN), caudal linear nucleus, and suprallemniscal region (Pineyro et al., 1999). The DRN is the largest of the brainstem serotonergic nuclei containing around 50– 60% of 5-HT neurons in the human CNS and innervates the neostriatum and cortical regions (Baker et al., 1990; Descarries et al., 1982).

The monoamine serotonin (5-hydroxytryptamine or 5-HT) is synthesised from tryptophan, which is converted inside the nerve terminal to 5-hydroxytryptophan (5-HTP) by the rate-limiting enzyme tryptophan hydroxylase (TPH) (Figure 1.7). Upon the release, serotonin is able to bind

to specific receptors on both presynaptic and postsynaptic terminal membranes. 5-HT receptor is seven transmembrane G protein coupled receptor that inhibits adenyl cyclase through G α proteins (Raymond et al., 2001), and in particular G α_i and G α_o subunits (Raymond et al., 1993), and reducing the levels of cyclic adenosine monophosphate (Bockaert et al., 1987).

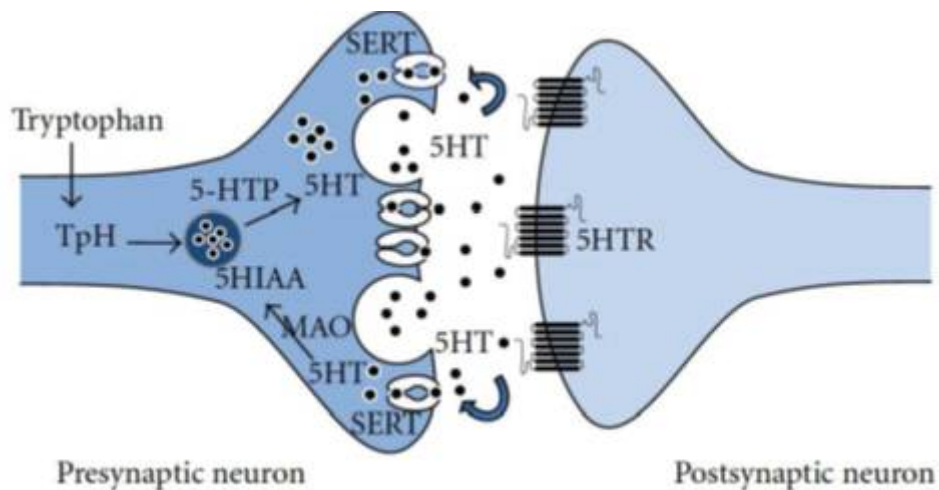

Figure 1.7. Schematic diagram depicting the major pathways involved in the synthesis, release, re-uptake and metabolism of serotonin in serotonergic neurons. TpH: tryptophan hydroxylase; 5- HTP: 5-hydroxy-L-tryptophan; 5-HT: serotonin; SERT: serotonin transporter; MAO: monoamine oxidase; 5-HIAA: 5-hydroxyindoleacetic acid; 5-HTR: serotonergic receptor. (Adopted from Buller et al., 2012).

The important role of 5-HT and its level in depression was suggested in several studies (Quan-Bui et al., 1984; Malison et al., 1998; Post et al., 1980; Lakshmi et al., 1992). Moreover, there is an increasing interest on the role of the 1A subtype of 5-HT receptors (5-HT_{1A}) in depression pathology (Savitz et al., 2009). The 5-HT_{1A} receptor is widely expressed somatodendritically (between the soma and dendritic branches) within the DRN (Sotelo et al., 1990) and postsynaptically on pyramidal cells and interneurons of the cortex, hippocampus, septum, hypothalamus and amygdala (Hensler et al., 1991). The stimulation of postsynaptic 5-HT_{1A} receptors (by 5-HT_{1A} agonists or 5-HT) is inhibitory on glutamatergic neurons (Sprouse et al., 1988). Indeed, it was reported from a number of human post-mortem and from 5-HT_{1A} knockout mice that the 5-HT_{1A} receptors are involved in depression pathology. Indeed, the analysis of depressed human patients post mortem has shown reduced 5-HT_{1A} receptor ligand binding in the ventrolateral prefrontal cortex and the temporal cortex as determined by autoradiography studies (Bowen et al., 1989), reduction in the 5-HT_{1A} receptor ligand binding in the caudal aspects of the dorsal raphe nucleus (Arango et al., 2001) and a reduced 5-HT_{1A} receptor mRNA expression in the dorsolateral prefrontal cortex and hippocampus (Lopez-Figueroa et al., 2004) as well as fewer serotonin transporter (SERT) binding sites (Mann et al., 2000). Reduced 5-HT_{1A} receptor expression and SERT binding site may reflect a compensatory mechanism in response to the hyposerotonergic state present in depressed patients (Mann et al., 2000). Moreover, it has been shown that the knockout mice of 5-HT_{1A} receptor produce anxious-like effects such as reduced exploratory behaviour and enhanced reactivity to fear cues (Heisler et al., 1998; Parks et al., 1998). Moreover, these mice showed an increase in immobility times in the tail suspension test compared with wildtype mice and could not be blocked by paroxetine and fluoxetine (Mayorga et al., 2001).

Other 5-HT receptors have been reported to be involved in depression such as the 5HT_{1B} receptor (Sari, 2004). The 5-HT_{1B} receptors are located on serotonergic neurons of the raphe nucleus (Doucet et al.,

1995) where they act as inhibitory autoreceptors by regulating 5-HT release (Sharp et al., 1989) and controlling serotonergic cell firing (Evrard et al., 1999). Moreover, it has been reported that the activation 5-HT_{1B} receptors inhibit the release of acetylcholine because they exist at the cholinergic terminals of the rat hippocampus (Maura et al., 1986). In addition, it has been reported that the levels of 5-HT_{1B} receptors were significantly lowered in the frontopolar cortex, hippocampus (females only), orbitofrontal cortex (males only), and higher levels in the paraventricular nucleus of suicide victims compared with healthy controls (Anisman et al., 2008). On the other hand, it has been found in autoradiography study that 5-HT_{1B} ligand receptor binding in the prefrontal cortex of suicide victims with major depression was not different from healthy volunteers (Huang et al., 1999). The link between depression and 5-HT_{1B} receptors still unclear. However, preclinical studies have suggested a possible link between 5-HT_{1B} receptors and the antidepressants mechanism of action. Indeed, chronic SSRI treatment can down-regulate and/or desensitize 5-HT_{1B} receptors in rats (Bluer et al., 1988; O'Connor et al., 1994). In addition, chronic treatment with fluoxetine was documented to reduce 5-HT_{1B} mRNA in the rat dorsal raphe nuclei and would be reversed by stopping the treatment (Neumaier et al., 1996). Moreover, it was reported that fluoxetine and paroxetine treatment were able to augment the increase in the 5-HT levels (in the frontal cortex and dorsal raphe nucleus of rats, respectively) after pretreatment with 5-HT_{1B} receptor antagonist GR 127935 (Davidson et al., 1995; Gobert et al., 1997). Moreover, the ability of fluoxetine to raise the 5-HT level was potentiated in the hippocampus in 5-HT_{1B} receptor knockout mice (Knobelman et al., 2001).

There also interactions between different monoaminergic transmitter systems in different brain regions that leads to changes in neurotransmitter release and function. For example, 5-HT activates dopamine release (Parsons and Justice, 1993; De Deurwaerdère et al., 1998; Zangen et al., 2001) in the NAc, through activation of the 5-HT_{1B/1D} (Yan and Yan, 2001) and 5-HT₃ receptors (Campbell and McBride, 1995).

1.6.1.2. Noradrenaline and depression

Noradrenergic neurons are mainly located in the locus coeruleus of the brainstem and project to the cortical, subcortical areas and to the spinal cord (Ressler et al., 1999). Noradrenaline is synthesized from the amino acid tyrosine. The conversion of tyrosine to dopamine occurs mainly in the cytoplasm then dopamine is converted to noradrenaline by dopamine β -monooxygenase that occurs predominantly inside neurotransmitter vesicles (Musacchio, 1975). After NA release, it binds to all three families' of adrenergic receptors (α 1Rs, α 2Rs and β Rs). The adrenergic receptors are seven transmembrane GPCRs and the activation of each family of these receptors causes different consequences.

The important role of NA and its level in depression was suggested in several studies (Belmaker and Agam, 2008; Krishnan and Nestler, 2008). In addition, the adrenergic system may interact with other brain systems, which may take part in development of depression. It has been reported that the administration of α 1 adrenergic receptor agonist phenylephrine stimulates 5-HT firing activity in the DRN and MRN, which suggests that the excitatory α 1 adrenergic receptors may have a role in 5-HT firing in the raphe nuclei (Judge et al., 2006), whereas α 1 adrenergic receptor antagonists suppress 5-HT neuron firing activity (Baraban et al., 1980). Moreover, chronically treated rats with antidepressants were shown to have increased α 1 binding (using [3H] prazosin as a ligand) in the cerebral cortex (Maj et al., 1985). In contrast, α 2 receptors are localized presynaptically as autoreceptors to regulate neurotransmitter release and have been implicated in the inhibitory control of adrenergic and serotonergic pathways innervating the frontal cortex (Dennis et al., 1987; Limberger et al., 1986). Indeed, it was reported that the effects of α 2 adrenergic receptors on serotonergic terminals are inhibitory and it regulate 5-HT release (Limberger et al., 1986). Moreover, the stimulation of α 2 adrenergic receptors has been documented to decrease NA output and suppresses the firing activity of 5-HT neurons in the dorsal raphe nucleus of rats (Clement et al., 1992). Chronic treatment with desipramine lead to hyporesponsive α 2 receptors resulting in raised levels of

NA in the dorsal hippocampus (Sacchetti et al., 2001). However, supersensitivity of the α_2 receptor may be a predisposing factor for depression. Post-mortem studies of depressed suicide victims found an increased level of α_2 adrenergic receptors in the prefrontal cortex compared with healthy controls (Garcia-Sevilla et al., 1999). In addition, it has been reported that the binding of NA transporter was decreased in locus coeruleus of postmortem samples from subjects diagnosed with major depression (Klimek et al., 1997). Moreover, it has been reported that the NA transporter knockout mice are resistant to the stress-induced depressive-like changes in behavior that are seen in wild-type mice (Haenisch et al., 2009).

1.6.1.3. Dopamine and depression

Increasing evidence and relationship between alterations in DA pathways and depression in the mesolimbic pathway has been suggested for many years (Nestler et al., 2006). Four main dopaminergic pathways were identified within the CNS include, nigrostriatal pathway that extends from the substantia nigra to the striatum, the tuberoinfundibular pathway which originates from the hypothalamus and projects to the pituitary gland, the mesocortical pathway and mesolimbic pathway (from the limbic area) which both originate from the ventral tegmental area and projects to the cortex (Dailly et al., 2004). DA receptors are located within these pathways and they are divided in two subfamilies: the D₁-like receptor subtypes (D₁ and D₅), which are coupled with the G_s protein activate adenylyl cyclase, and the D₂-like subfamily (D₂, D₃, and D₄), which are coupled with G proteins inhibit adenylyl cyclase (Missale et al., 1998).

D₁ and D₂ dopamine receptors are the most abundant subtypes in the CNS. D₁ mRNA is localized in the nucleus accumbens, striatum, olfactory tubercule, hypothalamus and thalamus and is post-synaptic receptors. However, The D₅ dopamine receptors distribution is localized to the hippocampus and thalamus and they are expressed at lower level than the D₁ dopamine receptors. The D₂ dopamine receptor is located mainly in the striatum, olfactory tubercule, nucleus accumbens, the substantia nigra pars

compacta, the ventral tegmental area and the pituitary gland. D₂ dopamine receptors are pre- and post-synaptic receptors. D₃ dopamine receptors are expressed in the limbic area and at a lower level in the striatum. The D₃ dopamine receptors exist as autoreceptors that inhibit neuronal dopamine synthesis and post-synaptic receptors. D₄ dopamine receptors were found with a low expression in the basal ganglia and a higher expression in the frontal cortex, amygdala, medulla and hypothalamus (Dailly et al., 2004; Jaber et al., 1996).

Increasing evidence from human and animal studies showed a possible relationship between dopamine and depression. Indeed, lower levels of DA and its metabolites have been documented in the serum and CSF of depressed patients (Engstrom et al., 1999). The deficits in dopaminergic signalling in the mesolimbic pathway have been suggested to cause the anhedonic symptoms often seen in depressed patient (Heinz et al., 1994; Nestler et al., 2006). Moreover, in human studies it was reported that there was a compensatory up-regulation of D₂ receptor density in the basal ganglia/ cerebellum in comparison with healthy volunteers (D'haenen and Bossuyt, 1994). In addition, it has been reported that there was an up-regulation of dopamine transporter that cause more re-uptake of dopamine into the pre-synaptic neurones in depressed patients (Laasonen-Balk et al., 1999). In addition, animal studies have shown a link between the D₂ receptor and depression. For example, Maj et al (1996) have reported an increase in the binding activity of the D₂-like agonist N-0437 in the limbic areas of the rat forebrain including the nucleus accumbens after chronic treatment with imipramine, amitriptyline and mianserin treatment. Also, treatment with imipramine or Mianserin for 14 days increased the binding of the D₂-like agonist quinpirole (Maj et al., 1998). Moreover, it was reported that the D₂-like agonists such as pramipexole (Willner et al., 1994) and quinpirole (Muscat et al., 1992) have antidepressive-like effects by increasing the sucrose consumption in stressed rats. Furthermore, reduction of immobility times in the FST by desipramine, imipramine, or amitriptyline was blocked by

injection of the D₂-like antagonist sulpiride in the nucleus accumbens (Cervo et al., 1988).

1.6.2. Neurogenic theory of depression and other mechanisms

Neurogenesis in adult is the proliferation and functional integration of new neurons with existing neurons and occurs in two main areas: the subventricular zone lining the lateral ventricles and subgranular zone of the hippocampus (Lledo et al., 2006). It was suggested that Adult neurogenesis could underlie the chronic adaptive neuronal processes of depression pathology and antidepressant action, as opposed to acute monoamine-mediated mechanisms (Castren et al., 2007). It has been reported that antidepressant treatment, including chronic fluoxetine administration (Malberg et al., 2000) and electroconvulsive treatment (Madsen et al., 2000), increase hippocampal neurogenesis in animal models.

The stimulation of the hypothalamic-pituitary-adrenal axis is one of the possible mechanisms through which the brain reacts to stress and consists of neurons in the paraventricular nucleus of the hypothalamus that release corticotropin-releasing hormone which in turn activates the synthesis and secretion of adrenocorticotropin from the anterior pituitary. Adrenocorticotropin then stimulates the production and release of glucocorticoids from the adrenal cortex in the form of corticosterone in rodents and cortisol in humans (Berton *et al.*, 2006). It was observed that excessive activation of the hypothalamic-pituitary-adrenal axis was in approximately half of patients diagnosed with depression and this activation was corrected with antidepressant treatment (Arborelius *et al.*, 1999; Holsboer, 2001). It was documented that antagonism of glucocorticoid receptors has been reported to enhance the antidepressive effects of fluoxetine (Johnson *et al.*, 2007; Johnson *et al.*, 2009). It has been documented that glucocorticoids inhibit adult neurogenesis (Duman *et al.*, 2006) and this effect can be reversed by the glucocorticoid antagonist mifepristone (Oomen *et al.*, 2007), these studies strengthen both the glucocorticoid and neurogenic theory of depression.

1.7. Current antidepressant pharmacotherapies

A large number of antidepressants are available which target the monoamine neurotransmitters 5-HT, NA and DA (Figure 1.8). These antidepressants are categorized into:

1.7.1. Tricyclic antidepressants (TCAs)

TCAs were discovered in the early 1950s and introduced to the clinic later in that decade. They were named because of their three rings of atom structure. TCAs such as imipramine, amitriptyline, desipramine and nortriptyline act by blocking the amine pump and thereby inhibiting re-uptake of norepinephrine and serotonin at the presynaptic neuron without blocking the reuptake of DA (Klerman and Cole, 1965; Kerr et al., 2001). They were considered for a long time as the first line of choice for treatment of depression. However, because of their side effects and the development of a new generation of agents with an improved safe profile (e.g. SSRIs) they were no longer considered first line of therapy (Anderson, 2000; López-Muñoz and Alamo, 2009). However, they are still occasionally used for treatment of patients that have failed to respond to other therapies (Broquet, 1999).

1.7.2. Monoamine oxidase inhibitors (MAOIs)

MAOIs act by inhibiting the activity of monoamine oxidase enzyme, which prevents the breakdown of monoamine neurotransmitters and increases their availability and restore their balance (Remick and Froese, 1990). Two isoforms of monoamine oxidase are known, MAO-A and MAO-B. MAO-A acts upon the following substrates 5HT, DA, NA. MAO-B acts upon phenylethylamine, DA and tyramine (Kanazawa, 1994). Phenelzine (Nardil) and tranylcypromine are examples of the non-selective irreversible MAOIs which are available clinically for the treatment of depression (Pitchot et al., 2011). However, the main disadvantage of these drugs is their lethal dietary

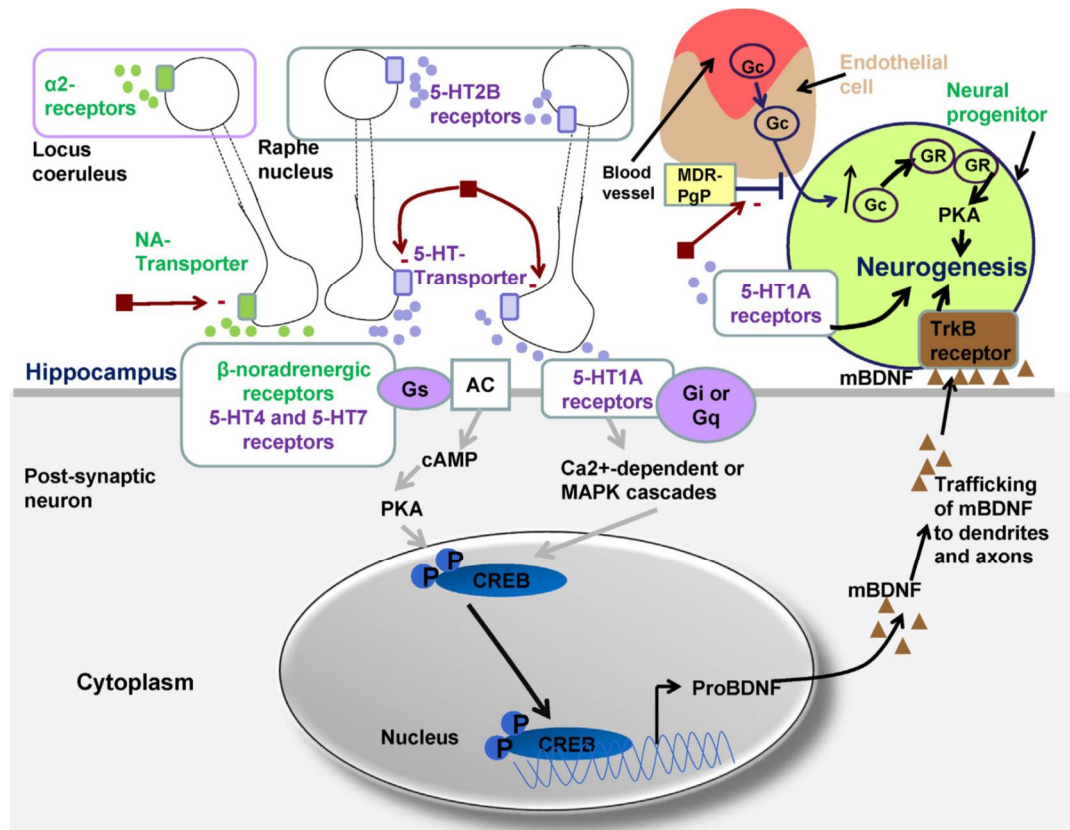

Figure 1.8 . Cellular and molecular mechanisms of antidepressant action (red arrows). Antidepressants act by increasing levels of 5HT (blue circles) and/or NA (green circles), which is generally achieved via inhibition of the 5HT and/or NA transporters. Serotonin then binds to 5-HT_{2B} positive (stimulatory) auto-receptors located in the raphenuclei and to 5-HT_{1A}, 5-HT₄ and 5-HT₇ post-synaptic receptors within the hippocampus, as well as to 5-HT_{1A} receptors located on hippocampal neural progenitor cells. NA binds to α 2 auto-receptors located in the locus coeruleus, and to hippocampal β -adrenergic receptors. Within the post-synaptic hippocampal neurons, activation of both serotonergic and noradrenergic receptors elicits activation of a cytoplasmic cascade of intracellular messengers. β adrenergic receptors as well as 5-HT₄ and 5-HT₇ receptors are coupled to Gs, so their stimulation will sequentially activate cAMP and PKA. On the other hand, 5-HT_{1A} receptors are coupled with Gi or Gq, which activates Ca²⁺-dependent cascades as well as MAPK. All of these pathways lead to phosphorylation of CREB in the nucleus of the cell, which induces transcription of the BDNF gene into pro-BDNF. In the cytoplasm, pro-BDNF will mature into mBDNF which is then trafficked to dendrites and axons. Once released, mBDNF binds to TrkB receptors located on neural progenitor cells, which will contribute to the maturation of these cells and their differentiation into new hippocampal neurons. The following actions have been shown to be essential for the neurogenetic and depression-relevant behavioural effects of SSRIs: stimulation of 5HT_{2B} auto-receptors; inhibition of synaptic 5HT uptake; stimulation of post-synaptic 5HT_{1A} receptors, and stimulation of MAPK, CREB, and BDNF. In parallel, antidepressants inhibit membrane pumps such as MDR-PGP and so increase access of Gc to the brain, resulting in a raised intracellular level of glucocorticoids (Gc), which bind to glucocorticoid receptors (GR). (These effects have been demonstrated in embryonic stem cells. The figure assumes that a similar process occurs in neural progenitors. It is unknown whether this also takes place in mature neurons.) Upon binding, GR activate PKA, leading to increased neurogenesis (probably via the CREB-BDNF pathway). GR also translocate to the nucleus, where the activated receptor can activate or repress transcription of specific genes, which inter alia causes a resensitization of GR. (Adopted from Willner et al., 2013)

and drug interaction. They interact with tyramine containing foods, like cheese, through the iso-enzyme MAO-B, Thus patients may suffer from what is called 'cheese effect', which could lead to hypertensive crisis, which can be fatal (Finberg and Gillman, 2011; Grady and Stahl, 2012). Thus, they have been kept as a last line of treatment, when other antidepressant classes have failed. This led to the development of reversible monoamine oxidase A inhibitors, e.g. moclobemide (Fitton et al., 1992). The advantage of new generation inhibitors is the absence of the 'cheese effect' (Remick and Froese, 1990; Finberg and Gillman, 2011).

1.7.3. The selective serotonin reuptake inhibitors (SSRIs) and Serotonin–noradrenaline reuptake inhibitor (SNRIs)

SSRIs are the most widely used antidepressants and considered the first line of choice for the treatment of depression. Moreover, they are used in the treatment of other related disorders such as generalized anxiety disorder, obsessive-compulsive behaviour, panic disorders and social phobia (Soomro et al., 2008; Capasso et al., 2009). It has been documented that the SSRIs act by selectively blocking the 5-HT reuptake transporter (Figure 1.3). However, how this leads to therapeutic benefit for the patient is not clear. Blockade of the reuptake transporter happens acutely and 5-HT levels at the synapse would be expected to increase rapidly. However, the therapeutic effects of SSRIs are reported to take 4-6 weeks before patients symptoms improve. Interestingly, they don't have improved efficacy compared to the TCAs and MAOIs but they are well tolerated and safer in overdose compared to other classes of antidepressants, because they are selective to 5-HT reuptake pumps, when compared to TCAs and MAOIs that affect other monoamine neurotransmitters and interact with other systems as well. SSRIs include Fluvoxamine, fluoxetine, citalopram, paroxetine and sertraline (Attard, 2012).

The SNRIs are a class of antidepressants that inhibit the reuptake of both 5-HT and NA. They include venlafaxine immediate release and extended release, desvenlafaxine, duloxetine and levomilnacipran.

Venlafaxine was introduced by Wyeth in 1994 and was the first and most commonly used SNRI. Both SNRIs and SSRIs share many of the same side effects because they both act similarly to elevate 5-HT levels (Attard, 2012; Nezafati et al., 2015). While SNRIs are generally safer than TCAs, SNRIs may cause an increase in pulse and blood pressure caused by the increased level of NA. Thus, they should be used with caution patient at risk for heart disease and hypertension (Taylor et al., 2013).

1.7.4. Atypical antidepressants

Mianserin and Mirtazapine are atypical antidepressants are generally receptor-blocking drugs. Mianserin is an example of the atypical antidepressants that was released as an antidepressant by Organon in Europe in the 1970s (Marshall, 1983). Mianserin is safe drug, which is unlike TCAs, because it's devoid of anticholinergic or cardiovascular side effects. However, sleepiness is the most common side effect, due to its high affinity for the histaminergic receptors (Shami et al., 1983; Marshall, 1983). Mianserin antidepressant action was suggested because its ability to increase 5-HT and NA neurotransmission by acting as an antagonist mainly at 5-HT₂ and α_2 adrenoceptor (Shami et al., 1983; Itoh et al., 1990).

1.7.5. Newer antidepressants

Within the past 5 years, two new antidepressant medications have become approved by the Food and Drug Administration for the treatment of major depression and became available in the United States of America: vilazodone in January 2011 and vortioxetine in September 2013 (Deardorff and Grossberg, 2014). It has been reported that the Vilazodone is a SSRI and a partial agonist at the 5-HT_{1A} receptor. Also, it has been shown that vortioxetine displays reuptake blockade of the serotonin transporter, agonist activity at the 5-HT_{1A} receptor, partial agonist activity at the 5-HT_{1B} receptor and antagonism at the 5-HT_{1D}, 5-HT₇, and 5-HT₃ receptors. Even the new antidepressants are still targeting monoamines and it has not been determined whether the antidepressant effects of these drugs are related to

its binding at various 5-HT receptors (Deardorff and Grossberg, 2014; Al-Sukhni et al., 2015).

1.8. Limitations of the current antidepressant

The current antidepressants are far from ideal, with a delay in their onset of action (4-6 weeks) (Claghorn et al., 1996; Taylor et al., 2006; Attard, 2012), almost half of depressed patients don't respond adequately (Fava and Davidson, 1996) and with significant side effects that may impair the patient's compliance and safety, which include nausea, headache, increased appetite and weight gain, loss of sexual desire and sexual dysfunction, agitation, irritability, anxiety, in some cases they increase the suicide thought and attempt (Khawam et al., 2006; Attard, 2012). In addition, it has been reported that patients who suffer from comorbid depression and anxiety have poor response to classic antidepressant treatments (Fava et al., 2008).

1.9. Evidence of involvement of kappa opioid receptor in depression and anxiety

It has been reported that sustained stressful events can increase the risk of developing psychiatric disorders such as depression and anxiety (Gold and Chrousos, 2002; Hunter and McEwen, 2013). Dynorphin is released during stress exposure (Bruchas et al., 2009; Shirayama et al., 2004; McLaughlin et al., 2003). It was documented that dynorphin released during exposure to chronic stress causes a prodepressive-like behaviour in rodents, including increased immobility in the forced-swim test (FST) (Shirayama et al., 2004). In addition, dynorphin reduced drug reward in reward models and this behavioral can be interpreted as a depressive-like effect, anhedonia (Bruchas et al., 2010; Todtenkopf et al., 2004), which is one of the main characteristics of depression.

Pfeiffer et al (1986) reported that activation of κ -receptor causes dysphoria in man. Moreover, it was reported in rats that microinjections of the κ -receptor agonist U50,488H and the dynorphin derivative E-2078 into

the VTA, NAc, medial prefrontal cortex (mPFC) and lateral HL produced place aversions (Bals-Kubik et al., 1993) (Table 1.4). Also, it has been reported by Carlezon et al (2006) that salvinorin A, a highly potent and selective κ -receptor agonist, dependently increased immobility time in the FST and did not affect locomotion in open field which may give an indication that the salvinorin A is prodepressive-like drug in rats. Thus, activation of κ -receptors is dysphoric in humans and prodepressive in preclinical studies.

In addition, κ -receptor gene deletion or prodynorphin gene disruption has the ability to block stress induced prodepressive-like effects (McLaughlin et al., 2003). Indeed, Wittmann et al (2009) have reported that mice lacking prodynorphin showed an increase in the exploration ability in elevated plus maze (EPM) consistent with an anxiolytic-like response. Also, it has been demonstrated that the high affinity κ -receptor antagonists, such as norbinaltorphimine (norBNI), effectively reduced stress induced prodepressive-like effects and produced a significant antidepressant-like effect in the FST (Mague et al., 2003; Filho et al., 2013; McLaughlin et al., 2003) (Table 1.5 and 1.6). Moreover, Knoll et al (2007) reported that κ -receptor antagonist NorBNI and (3R)-7-hydroxy-N-((1S)-1-[[[(3R,4R)-4-(3-hydroxyphenyl)-3,4-dimethyl-1-piperidinyl]-methyl]-2-ethylpropyl]-1,2,3,4-tetrahydro-3-isoquinolinecarboxamide (JDTic) dose-dependently raised open arm exploration in the elevated plus maze (EPM) without altering open field behaviour. They suggested that κ -receptor antagonist may be effective in the treatment of comorbid depressive and anxiety illness. In addition, Wittmann et al (2009) reported that the κ -receptor antagonist, 5'-guanidinonaltrindole trifluoroacetic acid (GNTI) and norBNI, showed a significant anxiolytic-like effect in mice. Moreover, Casal -Dominguez et al (2013) showed that novel 5'-AMN and 5'-MABN, which are mixed κ and μ -receptor antagonists, have significant antidepressant and anxiolytic-like effects at 7–14 days post-injection in mice.

Table 1.4. K-receptor agonists that have shown prodepressant-like behaviours in animal models of depression.

Drug	Test	Result	Species	Reference
U50,488	FST	Repeated forced-swim stress (FSS) increased immobility in wild-type C57Bl/6 mice, but not in littermates lacking the κ -receptor gene.	C57Bl/6 mice (male)	Todtenkopf <i>et al.</i> , 2004
U-69593	FST	Dose-dependently increased immobility	Sprague-Dawley rats (male)	Mague <i>et al.</i> , 2003
N-Methylacetamide	ICSS	Dose dependently elevated brain reward thresholds, equipotent to salvinorin A but has 6-fold longer lasting effects.	Sprague-Dawley rats (male)	Beguin <i>et al.</i> , 2008
Salvinorin A	FST, ICSS	Dose-dependently increased immobility in FST and elevated ICSS thresholds.	Sprague-Dawley rats (male)	Carlezon <i>et al.</i> , 2005
E- 2078		microinjections into the VTA, NAc, mPFC and lateral HL produced place aversions	Rat	Bals-Kubik <i>et al.</i> , 1993

FST, forced-swim test; ICSS, intracranial self-stimulation.

Table 1.5. Summary of the results of opioid receptors affinities (K_i) and antagonist potencies (K_e) of GNTI, JD_{TIC} and norBNI from different laboratories.

Ligand	K_i (nM)			K _i ratio		K_e (nM)				K_e (nM)		Reference
	k	μ	δ	μ/k	δ/k	k(GPI)	μ(GPI)	δ (MVD)	μ/k	δ/k		
GNTI	0.18±0.1	36.9±2.3	70. ±03	205	389	-	-	-	-	-	Jones & Portoghese, 2000	
	3	54	58	18	19.2	-	-	-	-	-	Munro et al., 2013	
	0.14±0.03	99.7±8.7	24.8±11.3	712	177	0.16	30.3	115	189	719	sharma et al., 2001	
	0.09±0.01	9.23±1.39	-	103	-	0.14	30	115	208	799	Jones et al., 1998	
	0.37±0.16	4.74 ± 1.96	2.86±1.45	12.8	7.7	-	-	-	-	-	Casal-Dominguez et al., 2014	
	1	3	44	3	44	-	-	-	-	-	Munro et al., 2013	
	0.41±0.10	0.96±0.01	29.6±11.9	2	72	0.01	3.41 ±0.36	79.3±9.3	341	7930	Thomas et al.,2003	
JD _{TIC}	0.32±0.05	3.73±0.17	301±50	12	940	0.02±0.002	2.16±0.75	>300	108	>15000	Thomas et al.,2001	
	-	-	-	-	-	0.02±0.01	25±4	76±3	1250	3800	Carroll et al., 2006	
	0.29±0.02	1.99 ± 2.38	0.46±0.09	7	1.5	-	-	-	-	-	Casal-Dominguez et al., 2014	
	-	-	-	-	-	12.5	10.6	0.41	30	26	Sharma et al.,2001	
	4	20	41	12	5	-	-	-	-	-	Munro et al., 2013	
	0.12±0.04	101.9±10.2	-	849	-	0.56	13.7	10.6	25	19	Jones et al., 1998	
	-	-	-	-	-	0.41	13	20	32	49	portoghese et al,1988	
	0.26	47	39	181	150	0.55	14	10.6	25	19	portoghese et al,1991,1994	
norBNI	0.244	49.7	41.5	204	170	0.4	13	11	33	28	Stevens et a.,2000	
	0.13	70	-	538	-	-	-	-	-	-	Larson et al., 2000	
	0.4±0.06	1.2±0.2	5.8±0.064	3	15	0.11±0.01	2.38±0.58	5.17±0.7	22	47	Chauvignac et al., 2005	
	1.09±0.14	65.06±7.3	86±7.3	60	79	0.038±0.005	16.7±1.5	10.2±1	439	268	Thomes et al.,2001	
	-	-	-	-	-	0.07 ± 0.03	15.8 ±5.7	12.1 ±3.1	225	173	Thomes et al.,2001	
	-	-	-	-	-	0.05±0.02	26±7	29±8	520	580	Carroll et al., 2006	

Table 1.6. K-receptor antagonists that have shown attenuation of stress, antidepressant- and anxiolytic-like behaviours in animal models.

Time point of k-receptor antagonist treatment or gene ablation	Behavioural Paradigm	Treatment (method)	Treatment time relative to 1st stressor	Behavioural Effect ¹	Species, strain	References
Before Stressors	Forced swim test	NorBNI (IP)	1 h before daily stress	Decreased Immobility ²	Mice, C57Bl/6	McLaughlin et al., 2003, 2006a; Carey et al., 2009
		5'-AMN 5'-MABN	6 days	Decreased Immobility	Male CD-1 mice	Casal-Dominguez et al., 2013
		NorBNI, GNTI (ICV)	3 days before	Decreased Immobility	Rats, CD	Pliakas et al., 2001; Mague et al., 2003
		KOR -/-	N/A	Decreased Immobility	Mice, C57Bl/6	McLaughlin et al., 2003; 2006a Filliol et al., 2000
		KOR -/-	N/A	Not Determined ³	Mice, Hybrid 129SV/C57Bl/6	McLaughlin et al., 2003; 2006a Filliol et al., 2000
		PDyn -/-	N/A	Decreased Immobility	Mice, C57Bl/6	McLaughlin et al., 2003
		PDyn -/-	N/A	Increased Immobility ⁴	Mice, C57Bl/6	Wittmann et al., 2009
	Social Defeat Stress	NorBNI (IP)	1 h before daily stress	Decreased Social Defeat	Mice, C57Bl/6	McLaughlin et al., 2006b
		PDyn -/-	N/A			
	Stress-Induced Potentiation of Cocaine-Conditioned Place Preference	NorBNI (IP)	1 h before daily stress	Blocked Stress-Induced	Mice, C57Bl/6	McLaughlin et al., 2003; 2006a; 2006b
		KOR -/-	N/A			
		PDyn -/-	N/A	No Effect in Unstressed Mice		
	Stress-Induced Reinstatement of Cocaine-Seeking	NorBNI (IP)	1 h before stress	Reinstatement No Effect on Cocaine-Primed Reinstatement	Mice, C57Bl/6	Redila & Chavkin, 2008
		KOR -/- PDyn -/-	N/A		Mice, C57Bl/6	
		Arodyn (ICV)		Reinstatement	Mice, C57Bl/6	Carey et al., 2007
		JDTic (IG)	24 h before stress	Decreased Stress-Induced Reinstatement	Rats, Long-Evans	Beardsley et al., 2005

Time point of κ -receptor antagonist treatment or gene ablation	Behavioural Paradigm	Treatment (method)	Treatment time relative to 1st stressor	Behavioural Effect1	Species, strain	References
NIH		DIPPA	24 hr before stress	Produced anxiolytic-like effects	rat	Carr and Lucki, 2010
		zyklophin	1 h		Male CD-1 mice	Huang et al., 2016
		LY2444296	1 h			
Stress-Induced Deficit in Novel Object Recognition		NorBNI (IP)	1 h before daily stress	Decreased Deficit in Novel Object Recognition	Mice, C57Bl/6	Carey et al., 2009
		PDyn -/-	N/A			
Elevated Plus Maze		NorBNI, JDTic (IP)	48h before	Increased Open Arm Exploration	Rats, CD	Knoll et al., 2007
		5'-AMN, 5'-MABN	7 days	Increased Open Arm Exploration	Male CD-1 mice	Casal-Dominguez et al., 2013
		PDyn -/-	N/A	Increased Open Arm Exploration	Mice, C57Bl/6	Wittmann et al., 2009
		KOR -/-	N/A	No Effect	Mice, Hybrid 129SV/C57Bl/6	Simonin et al., 1998
Zero Maze Open Field		PDyn -/-	N/A	Decreased Exploration	Mice, C57Bl/6	Bilkei-Gorzo et al., 2008
		KOR -/-	N/A	No Effect; Also No Effect Y maze	Mice, Hybrid 129SV/C57Bl/6	Simonin et al., 1998
Open Field		NorBNI (IP); GNTI (IC)	48h before; 20 h before	Increased Center Exploration	Mice, C57Bl/6	Wittmann et al., 2009
		NorBNI (IP)	3 days before	No Effect	Rats, CD	Knoll et al., 2007
		PDyn -/-	N/A	Increased Center Exploration	Mice, C57Bl/6	Wittmann et al., 2009
		KOR -/-	N/A	No Effect	Mice, Hybrid 129SV/C57Bl/6	Simonin et al., 1998

Time point of κ -receptor antagonist treatment or gene ablation	Behavioural Paradigm	Treatment (method)	Treatment time relative to 1st stressor	Behavioural Effect ¹	Species, strain	References
	Light-Dark Box	PDyn $-/-$	N/A	No Effect	Mice, C57Bl/6	Bilkei-Gorzo et al., 2008
		PDyn $-/-$	N/A	increased Time in Lit Area	Mice, C57Bl/6	Wittmann et al., 2009
	Fear-Potentiated Startle	NorBNI, JD _{Tic} (IP)	8 days before training; 10 days before testing	Decreased Conditioned Fear	Rats, CD	Knoll et al., 2007
	Stress-Induced Place Aversion	NorBNI	1 h before stress	Blocked Conditioned Place Aversion	Mice, C57Bl/6	Land et al., 2008
PDyn $-/-$		N/A				
Between Stressors	Forced Swim Test	ANTI (IP)	1, 19, 23 h after	Decreased Immobility	Rats, CD	Mague et al., 2003
		NorBNI, JD _{Tic} (SC)	After 1st swim session			Beardsley et al., 2005
	Learned Helplessness	NorBNI (NAc, HIP)	3 days before testing	Decreased Escape Failures (NAc, HIP)	Rats, CD	Shirayama et al., 2004
		NorBNI (ICV, NAc, HIP)	1 day after training	Decreased Escape Failures (ICV, NAc)		Newton et al., 2002
After Stressors	Stress-Induced Deficit in Novel Object Recognition	NorBNI (IP)	Immediately after 2nd swim session	Decreased Deficit in Novel Object Recognition	Mice, C57Bl/6	Carey et al., 2009

2- (3,4-dichlorophenyl)- N-methyl-N- [(1S)- 1-(3-isothiocyanatophenyl)- 2-(1-pyrrolidinyl) ethyl]acetamide hydrochloride (DIPPA), zyklophin, LY2444296, 5'-(2-aminomethyl) naltrindole (5'-AMN) and N-((Naltrindol-5-yl) methyl) pentanimidamide (5'-MABN), norBNI, GNTI, JD_{Tic}, and Arodyn are κ -receptor antagonists; PDyn $-/-$, prodynorphin knockout mice; KOR $-/-$, kappa receptor knockout mice; HIP, intra-hippocampus microinfusions; NAc, intra-nucleus accumbens microinfusions; ICV, intracerebroventricular; IC, intracisternal; IG, intragastric; IP, intraperitoneal; CD, Sprague Dawley; CPP, conditioned place preference; NOR, novel object recognition. Notes: 1 Behavioral effects in the forced swim test and social defeat stress paradigms are those observed during the second day of testing. Unless noted, in the forced swim test studies there was either no effect during the first swim session or behavior during this session was not examined; 2 Carey et al., 2009 also found decreased immobility during the first swim session; 3 Filliol *et al.*, 2000 used only one swim session; 4 swim session parameters differed from those typically used to study KOR antagonists.

It has been reported that κ -receptor agonists increases corticosterone level in rats (Laorden et al., 2000) and cortisol in humans (Ur et al., 1997) which are known as a stress hormones. On the other hand, norBNI (5 mg/kg) was effective in blocking U50,488H (15 mg/kg) induced an increase in the corticosterone increase in rat (Alcaraz et al., 1993; Victoria et al., 1994). There is evidence suggests that activation of the κ -receptors, after stress, causes a reduction in dopamine release in different brain region(Spanagel et al., 1992; Carlezon et al., 2006 ; Ebner et al., 2010; Belujon and Grace, 2015). Indeed, it has been reported that κ -receptor activation in the NAc region by dynorphin and κ -receptor agonists decreases dopamine release. In contrast, it has been shown that κ -receptor antagonist causes an increase in DA release (Spanagel et al., 1992; Maisonneuve et al., 1994). Moreover, Tejeda et al (2013) have showed that administration of the selective κ -receptor agonist U69, 593 into mPFC causes a reduction in DA release. However, this effect was antagonized by norBNI. Furthermore, κ -receptor has been shown to modulate 5-HT systems by reducing dorsal raphe and nucleus accumbens 5-HT efflux (Bruchas and Chavkin, 2010). These data could explain how κ -receptor antagonists work as possible antidepressants and support the claim that κ -receptors antagonist could play a critical role in regulating mood disorders.

1.10. Limitations of the existing κ -receptors antagonist

κ -receptor antagonists seem to play an important role in the regulation of mood states. However, all the existing high affinity selective κ -receptor antagonists (JDTic, 5'-acetamidinoethylnaltrindole (ANTI), GNTI and norBNI) have two distinct pharmacological properties; slow onset of antagonist activity and very long lasting effects in vivo (up to 56 days following a single dose) (Béguin and Cohen, 2009), which limits and complicates experimental design for in vivo behavioural testing, interpretation and clinical trials if the blockade of κ -receptors may not be easily reversed. For example, one injection of norBNI has peak effects starting about 24 h post-administration, maintained heights levels for 7–10 days and reached control levels after 3–4 weeks (Endoh et al., 1992).

Moreover, it has been reported by Horan et al (1992) that norBNI at high doses has duration of action that stays for several months in mice. Furthermore, GNTI and JD_{Tic} have similar long-lasting effects and produce antagonism for at least 10–14 days (Negus et al., 2002; Carroll et al., 2004). These findings are surprising because these antagonists do not covalently bind to κ -receptors (Smith et al., 1990)

It is unclear how the κ -receptor antagonists produce their long-lasting effects in vivo. However, it has been suggested that they may become physically trapped in the lipid membrane of the nervous system and may not clear easily. Another explanation is that they could be bio-transformed in vivo to long-lasting metabolites that covalently bind to the receptor. Moreover, these κ -receptor antagonists may acutely uncouple the κ -receptor signalling complex, which prevent the agonists from activating the receptor (Bruchas et al., 2007). Therefore, there is a need to find a drug or combination that is short acting κ -receptor antagonist to understand the κ -receptor antagonist activity.

1.11. Recent short-acting κ -receptors antagonists

In the past few years, there were some considerable advances in the designing and production of short-acting κ -receptors antagonists. Aldrich et al., (2009) were able to show that the systemic administration of zyklophin (3 mg/kg s.c.) is active with much shorter of duration (less than 12 h) than norBNI in antagonizing U50,488-induced antinociception, in the warm water tail withdrawal assay, and in inhibiting stress-induced reinstatement of cocaine-seeking behavior in mice. Moreover, Melief et al (2011) examined various analogues of JD_{Tic} and diaryl ethers they used C57BL/6 wild type mice to determine the durations of antagonist action of novel κ -receptor antagonist compared with conventional competitive antagonists. They showed that blockade of U50,488-induced antinociception, after systemic administration (i.p.) of RTI-5989-212 (10 mg/kg), RTI-5989-240 (10 mg/kg), JSPA0658 (10 and 50 mg/kg), JSPA071B (10 and 50 mg/kg), PF4455242

(10 mg/kg), FP3FBZ (10 mg/kg) and naloxone (10 mg/kg) lasted less than 1 d in the warm water tail withdrawal test.

1.12. Hypothesis and aims of the study

The hypothesis of this thesis is that the combination of buprenorphine/naltrexone and the novel compound BU10119 (Figure 1.4), which is buprenorphine analogue, could be a functional short-acting κ -receptor antagonist with antidepressant and anxiolytic activity.

It is documented that buprenorphine is a semi-synthetic opioid with unique complex pharmacological activities; acting as a partial μ -receptor agonist and a κ -receptor antagonist (Mello and Mendelson, 1985), NOP receptor agonist (Lutfy and Cowan, 2004) and δ receptor antagonist (Kajiwara et al., 1986). Clinically buprenorphine is used as a potent analgesic and as an alternative to methadone in the treatment of opioid addiction (West et al., 2000). Also, it was found to be effective in treatment of refractory depression (Bodkin et al., 1995). Buprenorphine has two properties that distinguish it from other opioids. It has a bell shaped analgesic dose–response curve (Lutfy et al., 2003) and a ceiling effect for respiratory depression (Dahan et al., 2006). Therefore, buprenorphine is an attractive compound for use in clinical trials because of low potential toxicity and overdose (Kakko et al., 2007; Hayes et al., 2008). However, the buprenorphine opioid agonist effects could pose a risk for abuse (Casati et al., 2012). A formulation combining buprenorphine with naltrexone, opiate antagonist, could discourage, reduce such abuse and may enhance κ -receptor antagonist of buprenorphine and such combination may work as a functional short acting kappa antagonist which could be helpful in treatment of depression and anxiety. Indeed, Cordery et al (2104) reported that a combination of 0.3 mg/kg buprenorphine and 1.0 mg/kg naltrexone, in adult Sprague Dawley rat, was neither rewarding nor aversive. Moreover, Gerra et al (2006) reported that buprenorphine and naltrexone combination may significantly reduce dysphoria, mood symptoms and craving of heroin in addicted people. Furthermore, BU10119 is a novel compound with a

pharmacology resembling buprenorphine/naltrexone combination (Ridzwan, 2012) and it is predicted that it may be helpful in treatment of depression and anxiety.

All experiments were conducted in adult male CD1 mice. The first aim of this study was to establish appropriate dose of buprenorphine/naltrexone combination that produce the desired pharmacology and to test the duration of the κ -receptor antagonist effect in the warm water tail withdrawal test (chapter 3). Alongside this, the in vivo opioid pharmacology of the novel compound BU10119 was investigated. An important aim was to establish that the combination of buprenorphine/naltrexone and BU10119 were not rewarding nor aversive if these compounds are to be developed in the clinic (chapter 4). The compounds were also assessed for their locomotion effects which is an important confound of behavioural experiments. Subsequently the antidepressant and anxiolytic-like potential of buprenorphine/naltrexone and BU10119 was established in pharmacologically validated behavioural tasks (chapter 5). The final aim was to test the ability of buprenorphine/naltrexone and BU10119 to block stress-induced changes in behaviour, corticosterone and κ -receptor, prodynorphin and CRHR1 gene expression (chapter 6)

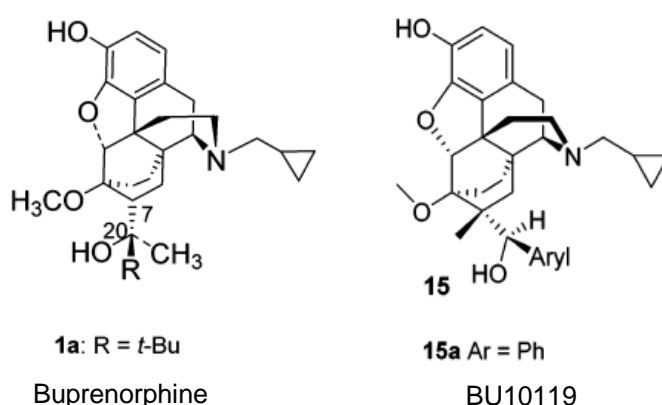

Figure 1.9. Chemical structures of buprenorphine and BU1119 (Adopted from Ridzwan, 2012).

Chapter 2

General material and methods

2. General material and methods

2.1. Animals

Adult (8–10 weeks, 27–38 g) male CD-1 mice, from University of Bath and Charles River, were housed in groups of 4 in cages provided with a shelf, wood shavings and nesting material with ad libitum access to food and water and maintained on a 12:12 hours light–dark cycle (lights on 7:00 am, lights off 7:00 pm). All experiments were performed in accordance with the UK Home Office guidelines and the Animals (Scientific Procedures) Act 1986. For all behavioural tasks animals were habituated to the behavioural room for one hour prior to the experiment beginning. Separate groups of animals, n=5-18 per treatment group, were used for studies of behaviour task. All behavioural experiments were performed between 9:00-16:00 h and mice were acclimatized to the behavioural room for 1h prior to starting.

2.2 Drugs

Diazepam and U50,488 were purchased from Sigma (Dorset, UK). Fluoxetine and naltrexone were supplied by Abcam Biochemicals (Cambridge, UK). Clocinnamox (CCAM) and norBNI were obtained from Tocris Bioscience (Bristol, UK). Buprenorphine was purchased from MacFarlan Smith (Edinburgh, UK) and BU10119 (Table 2.1) (μ agonist and k-antagonist) was synthesized in the Department of Pharmacy and Pharmacology, University of Bath (kindly provided by Prof S. Husbands). For in vivo experiments, all drugs were dissolved in 0.9% w/v saline (Hameln Pharmaceuticals, Gloucester, UK) and injected via the intraperitoneal route at a volume of 10 mL/kg, except for CCAM which was injected at a volume of 20 mL/kg. All drugs were administered 1 hour before testing (naltrexone 10 min before buprenorphine). However, The irreversible μ -antagonist CCAM (3 mg/kg), administered 24h before buprenorphine.

Table 2.1. summary of the κ -receptors selectivity on μ - κ - δ and ORL-1 receptors (IUPHAR receptor database; accessed 06/12/2016)

	μ	κ	δ	ORL-1
Buprenorphine	Partial agonist	Antagonist	Antagonist	partial agonist
Naltrexone	Antagonist	Antagonist	Antagonist	
U50,488		Agonist		
BU10119	Antagonist	Antagonist	Antagonist	partial agonist
CCAM	Antagonist			
norBNI		Antagonist		

Chapter 3

Establishing the k-receptor antagonist properties of test compounds in vivo

3.1. Introduction

Endogenous opioid neuropeptides and non-opioid analgesics are widely used in pain treatment. Opioids, such as morphine, acting through μ -opioid receptors, remain the first line for the treatment of severe pain (Gutstein and Akil, 2001; McNally and Akil, 2002). Morphine is effective in treating acute pain but there is a lack of its analgesic efficacy in neuropathic pain in many clinical studies (Arner and Meyerson, 1988; Cherny et al., 1994). However, opioids may cause serious side effects such as respiratory depression and dependence which limits their use (Bohn and Raehal, 2006). Thus, numerous studies have been made to improve opioid analgesic properties and to reduce their adverse consequences.

There is a potential role for the dynorphin- κ -receptors system in analgesia of neuropathic pain (Kieffer and Gaveriaux-Ruff, 2002). Dynorphins and κ -receptors are distributed widely in the brain, spinal cord and periphery (Mansour et al., 1995). Centrally κ -receptors are involved in thermal nociception through spinal. Indeed, κ -receptors are primarily located in the cell bodies of small myelinated and unmyelinated nociceptive afferents in the dorsal root ganglion and spinal cord (Peckys and Landwehrmeyer, 1999). Peripherally activation of κ -receptors produce antinociceptive effects in visceral pain (Iadarola et al., 1988; Horan and Porreca, 1993; Millan et al., 1988; Vanderah, 2010). Enadoline, a selective κ -receptor agonist, produced a good analgesic efficacy in animal models for mechanical and chemical noxious stimuli (Hunter et al., 1990). Moreover, in a postsurgical pain clinical study, enadoline at a dose of 25 mg significantly produced analgesic effect compared with placebo and the analgesia obtained was similar to that from 10 mg of morphine injected intramuscularly (Pande et al., 1996). However, when enadoline crossed the blood-brain barrier dysphoria became a dose-limiting side effect for these patients and the study was stopped. It has been reported that ADL10-0101, a peripherally acting selective κ -receptor agonist, was effective in treating chronic visceral pain (Eisenach et al., 2003). Thus both κ and μ -receptors are implicated clinically in analgesic responses.

Analgesic effects of opioid compounds can also be identified in animals. Painful stimuli in animals can be induced by inflammation or by stimulation of nociceptors by various stimuli including electrical, chemical, mechanical and thermal (Le Bars et al., 2001). In this thesis, the warm water tail withdrawal test has been used. There are two variants of the tail-withdrawal test (also called tail-flick test). The first one is the tail-flick test using radiant heat (a light beam) to a small surface of the tail. The second type is immersing the tail in the water at a certain temperature, either warm or cold (Le Bars et al., 2001). At a physical level, these two tests are different: the cutaneous temperature varies with the square root of time in the case of radiant heat and more rapidly in the immersion case. Moreover, stimulated surface areas can be very different. Tail immersion in warm water causes an immediate movement of the tail and sometimes the recoiling of the whole body. Both tests cause the tail to withdraw from noxious stimuli and this reflex is monitored (usually called tail-flick latency). An increase in the tail-flick latency is interpreted as an analgesic action. These methods are considered simple, easy to apply, sensitive to known analgesics and show little variability in the recording of the reaction time under a controlled condition (Le Bars et al., 2001). These tests have been widely used to characterise opioid ligands. It has been reported that lower temperatures in tail immersion test might be used to investigate the effects of minor analgesics and the test is useful to differentiate central opioid like analgesics from peripheral analgesics (Luttinger, 1985). Also, these tests have been widely used to characterise opioid ligands. It has been suggested that the tail-flick reflexes are a spinal reflex (Bonnycastle et al., 1953; Sinclair et al., 1988). Also, these reflexes can be controlled by supraspinal structures (Mitchell and Hellon, 1977; Grossman et al., 1982; Carstens and Wilson, 1993; Douglas and Carstens, 1997).

It has been reported that opioid agonists exert their analgesic action in the mouse and rat tail withdrawal test by a dual mechanism: by direct inhibition of nociceptive neurones in the spinal cord and by acting in the supraspinal areas involved in pain modulation (Kolesnikov et al., 1996).

Moreover, it has been reported that a synergistic interaction between these two sites produces the antinociceptive effect in the warm water tail withdrawal test but not the hot-plate test (Hurley et al., 1999).

3.2. Chapter aims

In this chapter, the warm water tail withdrawal assay has been used to establish the appropriate doses of buprenorphine and naltrexone required to achieve a functional κ -receptor antagonist in vivo. Additionally, for the novel compound BU10119 it was essential to confirm its opioid receptor pharmacology profile in vivo. This assay was also used to establish the duration of the κ -receptor antagonist effects. In addition, the potential sedative effects of all test compounds were examined in an open field locomotor assay.

3.3. Method

3.3.1. Tail withdrawal test

Each mouse was scruffed and held in a vertical position and the distal third of the tail (the last 2 cm of the end of the tail was then placed into the beaker of warm water) lowered into a 1-litre beaker of warm water maintained at a constant temperature at 52°C on a stirring hotplate. The latency for the tail withdrawal was recorded using a stopwatch. A 15-second cut-off was imposed to avoid tissue damage. Antinociception was calculated as percentage maximum possible effect (%MPE) = (test latency–control latency)/(15 s–control latency) ×100.

To counteract any possible confounding effects of injection induced stress, in all experiments, animals received 0.9% w/v saline injections so that the total number of injections an individual mouse received, whether in control or drug-treated groups was equivalent (Almatroudi et al., 2015; Casal-Dominguez et al., 2013).

To determine the time course of the antinociceptive effects of buprenorphine (0.3, 1 and 3 mg/kg) (Figure 3.1), baseline latencies were determined 30 minutes before injecting these drugs at time zero. Also, the κ -agonist U50,488 (10 mg/kg) antinociceptive effects were investigated and baseline latencies were determined 30 minutes before injecting at zero time (Figure 3.6). To determine effective μ and κ -antagonist doses (Figure 3.3 (a–b)), naltrexone (0.3, 1 and 3 mg/kg) was injected 10 minutes prior to buprenorphine or U50,488 administration. Tail withdrawal responses were measured at 30, 60, 120, 240 minutes and 24 hours post-injection.

To examine the duration of the κ -receptor antagonist actions (Figure 3.8 (e)), tail withdrawal latency was measured at 1, 8, 24 and 48 hours post-administration of the antagonist, naltrexone (1 mg/kg) alone, or in combination with buprenorphine (1 mg/kg). In these experiments, naltrexone or saline was injected 10 minutes before time zero. Buprenorphine or saline

was injected at time zero. U50,488 or saline was injected 30 minutes before taking a measurement to assess the extent of the κ -receptor blockade. In experiments with the irreversible, selective μ -receptor antagonist CCAM (Broadbear et al., 2000), CCAM was administered 24 hours before treatment with buprenorphine/naltrexone (1 mg/kg) combination.

BU10119 (0.3, 1 and 3 mg/kg) and buprenorphine (1 mg/kg) were tested for antinociceptive effects at 60, 120, 240 minutes post-injection, baseline latencies were measured 30 minutes before injecting the drug (Figure 3.11A). To determine the duration of the κ -receptor antagonist actions of BU10119 (0.3, 1 and 3 mg/kg) (Figure 3.11B), tail withdrawal latency was measured at 1, 8, 24 and 48 hours post-administration. BU10119 (1 mg/kg) and norBNI (1 mg/kg) or saline were injected at time zero. Baseline latencies were measured immediately before injecting U50,488 30 minutes before taking the measurement to assess the extent of the κ -receptor blockade of κ -receptor antagonists.

The μ -receptor antagonist activity of BU10119 (0.3, 1 and 3 mg/kg) and the irreversible, selective μ -receptor antagonist CCAM (3 mg/kg), was tested against buprenorphine (1 mg/kg) and morphine (10 mg/kg). CCAM was administered 24 h before treatment with buprenorphine (1 mg/kg) or morphine (10 mg/kg) (Broadbear et al., 2000). Baseline latencies were measured immediately before injecting BU10119 or saline injection. Buprenorphine and morphine were injected 30 minutes after BU10119 injection (Figure 3.11C). Also, tail withdrawal latency was measured at 60 minutes after Buprenorphine and morphine injection (Figure 3.11D).

3.3.2. Locomotor activity test

Locomotor activity was assessed in an open-field test. Testing was performed to establish the potential sedative effects of buprenorphine (0.3, 1 and 3 mg/kg) alone or in combination with naltrexone (0.3 mg, 1 mg, and 3 mg/kg). Naltrexone was injected 10 minutes before buprenorphine. One hour post-administration, mice were placed singly in an open field (72x72 cm) for

10 minutes under low light conditions (30 lux). Total activity was recorded by photobeam breaks using Motor Monitor software (Campden Instruments) (Almatroudi et al., 2015; Casal-Dominguez et al., 2013).

3.4. Statistical analysis

Locomotor data were analysed using one-way ANOVA and tail flick data were analysed using two-way repeated measures mixed model analysis (Clark et al., 2012). Then, Unadjusted Least Significant Difference (ULSD) were used as Post hoc test (InVivoStat 2.3). Only planned pairwise tests were carried out and p values adjusted for multiple comparisons with Benjamin–Hochberg correction. Values are reported as mean \pm standard error of the mean (SEM) for each treatment group, n = 5 to 6 per treatment group depending on the behavioural paradigm.

3.5. Result

3.5.1. Establishing that a combination dose of buprenorphine/naltrexone and single dose of BU10119 is a functional kappa opioid receptor antagonist

Doses of buprenorphine (0.3-3 mg/kg) that would provide robust antinociception via activation of μ -opioid receptors in the warm water tail withdrawal assay were established (Figure 3.1). Doses of naltrexone, a relatively nonselective opioid receptor antagonist (Giordano et al., 1990) that would block the partial μ -receptor agonist activity of buprenorphine using the warm water tail withdrawal test were established (Figure 3.3A, B, n=5 per group). In buprenorphine dose response curve, two-way repeated measures mixed model analysis showed a significant interaction of Treatment * Time ($F_{(9,60)} = 19.90$, $p < 0.001$). Buprenorphine (1 and 3 mg/kg) produced a significant antinociceptive effect that peaked at 60 min post-administration ($p < 0.001$, compared to saline injected controls, figure 3.1). However, only buprenorphine at the dose of 0.3 and 1 mg/kg returned to baseline after 240 min. Furthermore, in this dose range, one-way ANOVA revealed no significant main effects of doses of treatment on locomotion ($F_{(4, 25)} = 3.66$, $p > 0.05$) (Figure 3.2).

In the second experiment, two-way repeated measures mixed model analysis revealed a significant interaction of Treatment * Time ($F_{(24,120)} = 2.46$, $p < 0.001$). Buprenorphine (1mg/kg) produced a significant antinociceptive effect that peaked at 60 min post-administration ($p < 0.001$, compared to saline injected controls, figure 3.3 B) returning to baseline after 240 min (Figure 3.3 A). Pre-treatment with naltrexone 1mg and 3mg/kg, but not 0.3mg/kg, significantly blocked the buprenorphine-induced antinociception at 30 min ($p < 0.01$), 60 min ($p < 0.001$) and 120 min ($p < 0.001$). Moreover, naltrexone 1mg/kg alone or in combination at doses of 0.3, 1 and 3 mg/kg were without a significant effect on locomotor activity ($p > 0.05$) (Figure 3.2 and 3.4).

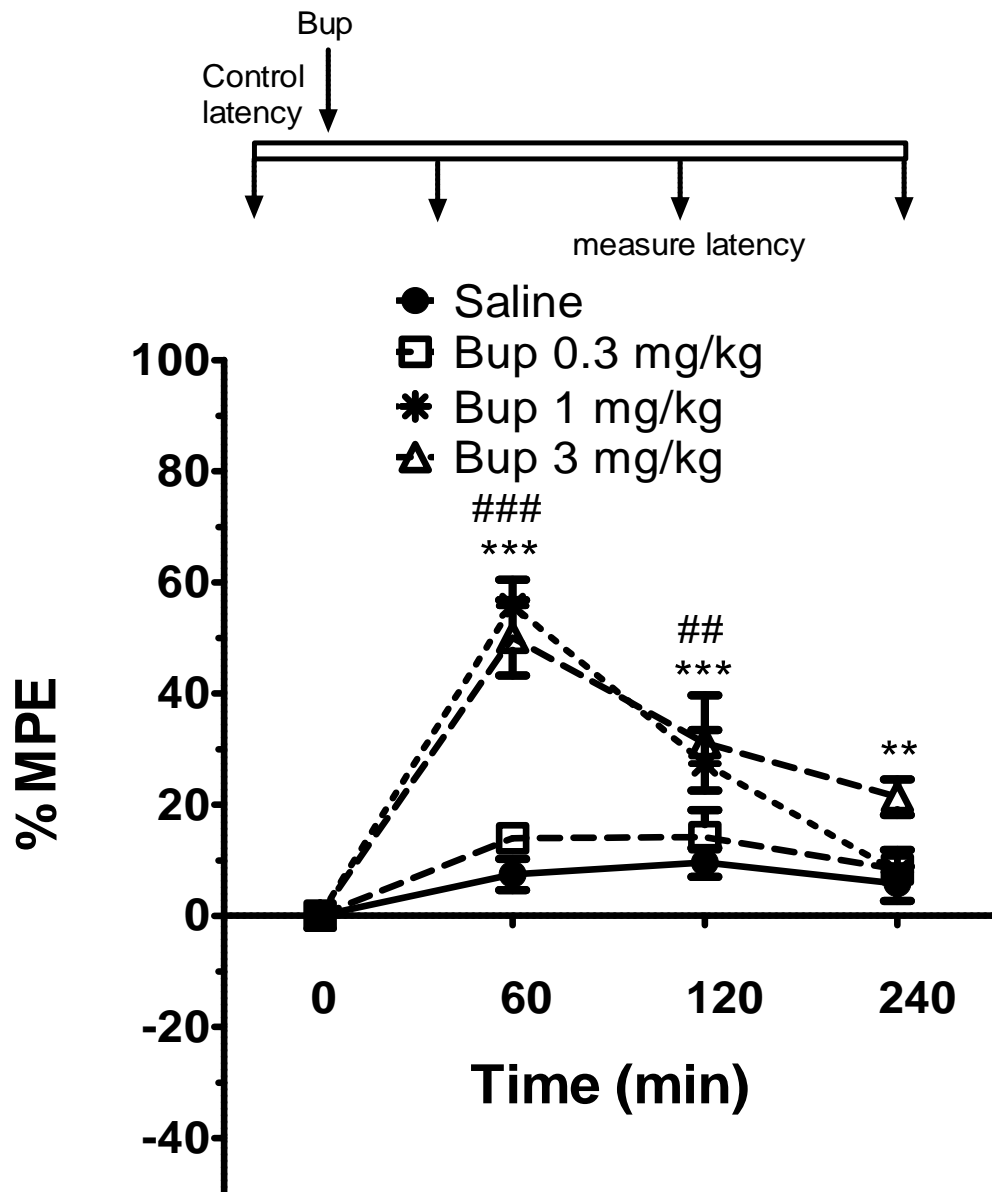

Figure 3.1. Antinociceptive effects of buprenorphine (Bup) (0.3,1 and 3 mg/kg) in the mouse tail withdrawal assay. Two-way repeated measures mixed model analysis was used. Buprenorphine was injected at zero time immediately after baseline measurement. All values are mean \pm SEM, n= 6 per group. **p< 0.01 as compared between Bup 3 mg/kg and all treatment groups ; ***p< 0. as compared between Bup (1 and 3 mg/kg) and saline and Bup 0.3;## p<0.01and ;### p<0.001 as compared between Bup 1 mg/kg and saline and Bup 0.3.

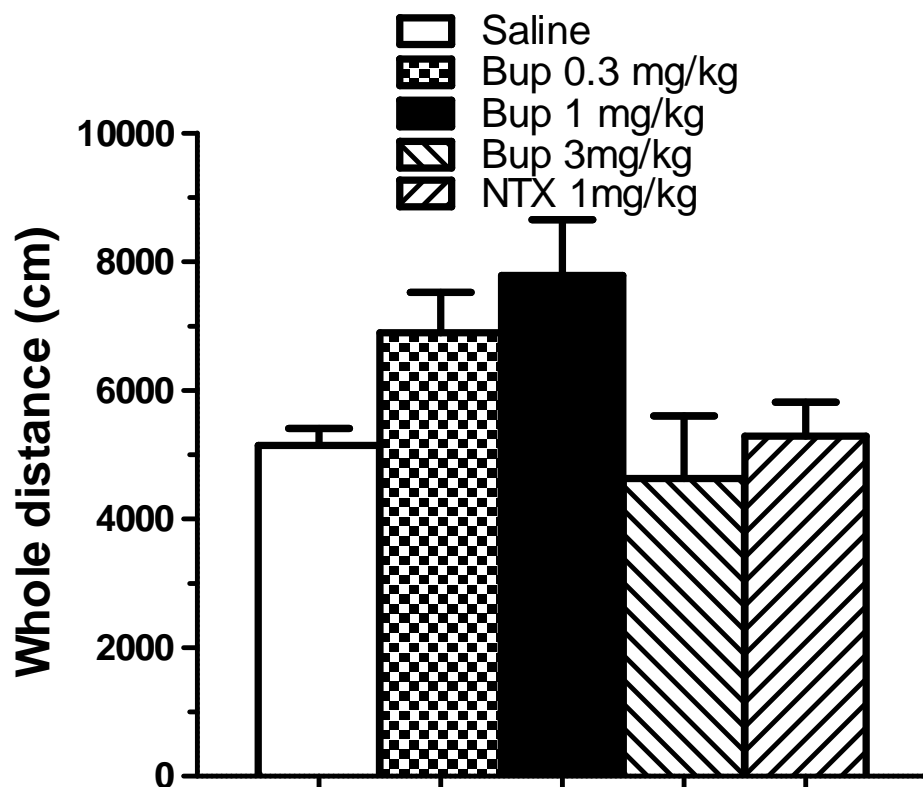
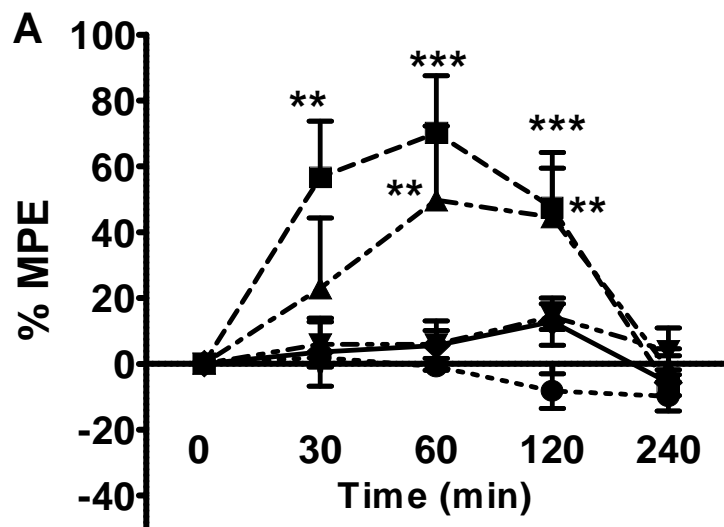
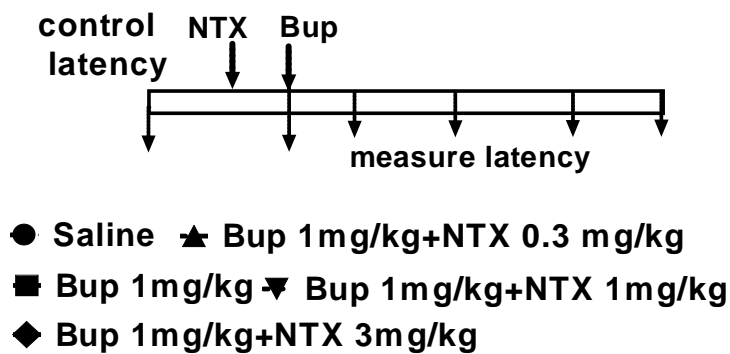

Figure 3.2. Locomotor activity in the open field in mice treated with buprenorphine (Bup) (0.3, 1 and 3mg/kg) and naltrexone (NTX) (3mg/kg). One-way ANOVA was used. All values are mean \pm SEM, n= 6 per group.



□ Saline ■ Bup 1mg/kg ▨ Bup 1mg/kg+NTX 0.3mg/kg
 ■ Bup 1mg/kg+NTX 1mg/kg ▩ Bup 1mg/kg+NTX 3mg/kg

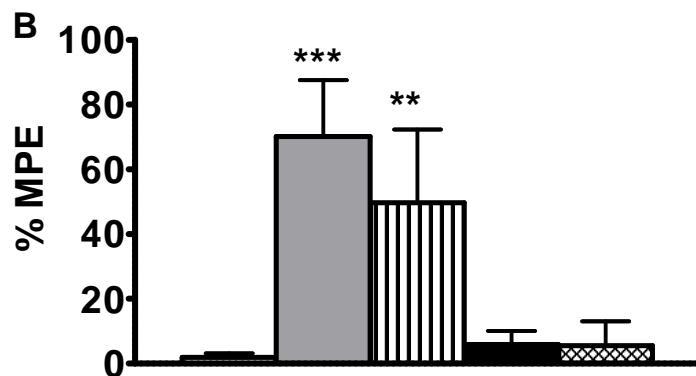

Figure 3.3. Antinociceptive effects of buprenorphine (Bup 1mg/kg) were blocked by naltrexone (NTX) in the mouse tail withdrawal assay. (A) The time course of the experiment. (B) The antagonist effects of naltrexone (NTX) at 60 min post-administration of agonist. Naltrexone (NTX) dose-dependently blocked buprenorphine-induced antinociception (** $p < 0.01$; *** $p < 0.001$ compared to saline control). Two-way repeated measures mixed model analysis was used. All values are mean \pm SEM, $n = 5$ per group.

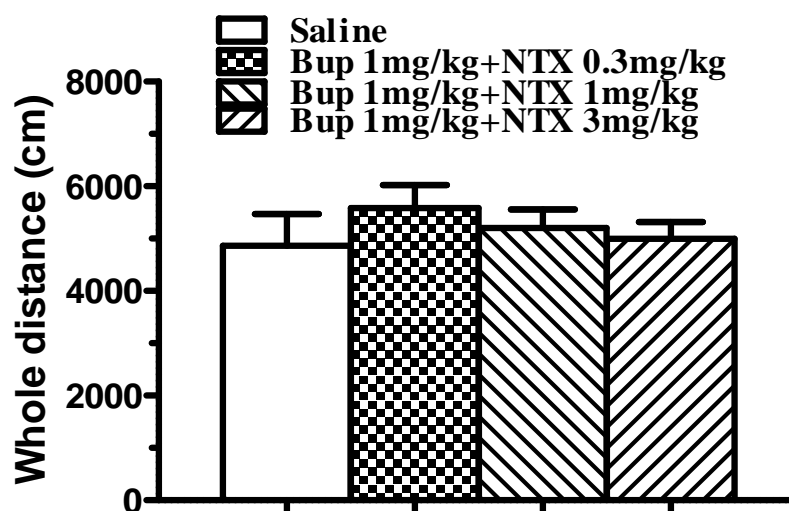

Figure 3.4. Locomotor activity in the open field in mice treated with buprenorphine (Bup 1 mg/kg) combination with naltrexone (NTX 0.3, 1 and 3mg/kg). All values are mean \pm SEM, n=5 per group.

To determine the κ -antagonist properties of naltrexone, the κ -receptor agonist U50,488 (5 and 10mg/kg) was used to establish its effective antinociceptive dose (Figure 3.5, n=5 per group). Two-way repeated measures mixed model analysis showed a significant interaction of Treatment * Time ($F_{(8,40)} = 5.63$, $p < 0.001$). Only U50,488 (10 mg/kg) produced a significant antinociceptive effect that remained effective for 240 min (all p's < 0.001 , compared to saline). In the next experiment, U50,488 (10 mg/kg) (Figure 3.6, n=5 per group) was used and there was a significant Treatment * Time interaction ($F_{(24,114)} = 2.12$, $p < 0.004$). U50,488 produced a significant antinociceptive effect 30 min post-administration ($p < 0.01$) that persisted for more than 240 min ($p < 0.05$ compared to saline controls). Pretreatment with naltrexone 1mg and 3mg/kg, but not 0.3 mg/kg, significantly blocked the U50, 488-induced antinociception (all p's < 0.01 compared to U50,488 alone). However, only naltrexone at a dose of 10 mg/kg was able to block the significant sedative effect of U50, 488 ($p < 0.001$) on locomotor activity (Figure 3.7).

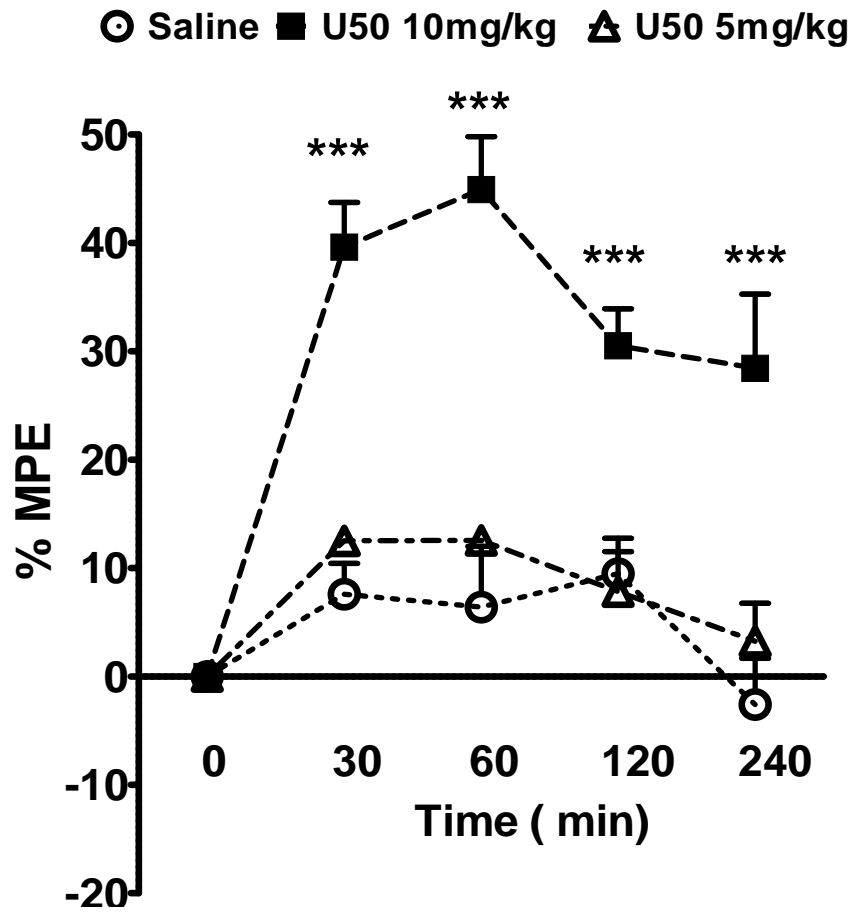

Figure 3.5. Antinociceptive effects of U50,488 (U50, 5 and 10 mg/kg) in the mouse tail-withdrawal assay. Two-way repeated measures mixed model analysis was used. *** $p < 0.001$; U50 10 mg/kg compared to saline control. All values are mean \pm SEM, $n = 5$ per group.

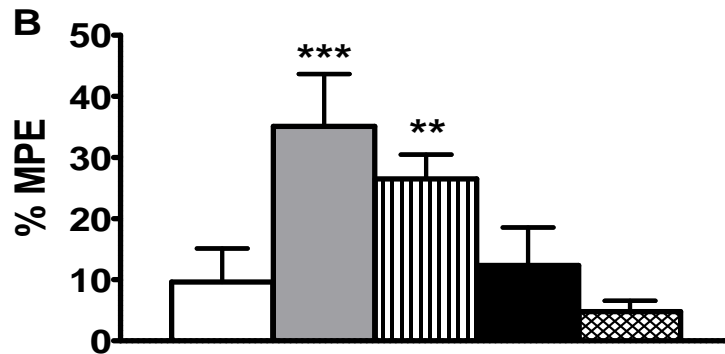
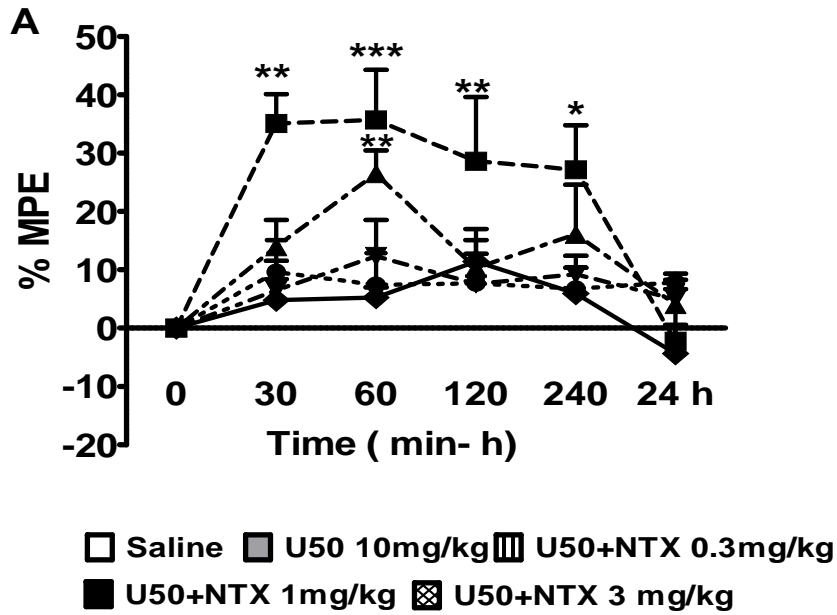
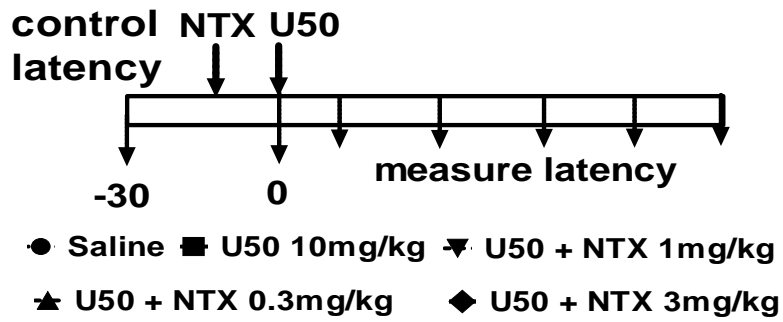

Figure 3.6. Antinociceptive effects of U50,488 (U50, 10 mg/kg) were blocked by naltrexone (NTX) in the mouse tail withdrawal assay. (A) The time course of the experiment. (B) The antagonist effects of naltrexone (NTX) at 60 min post-administration of agonist. Naltrexone (NTX) dose-dependently blocked U50,488-induced antinociception ($p < 0.05$; $**p < 0.01$; $***p < 0.001$) as U50 compared to saline control. Two-way repeated measures mixed model analysis was used. All values are mean \pm SEM, $n = 5$ per group.

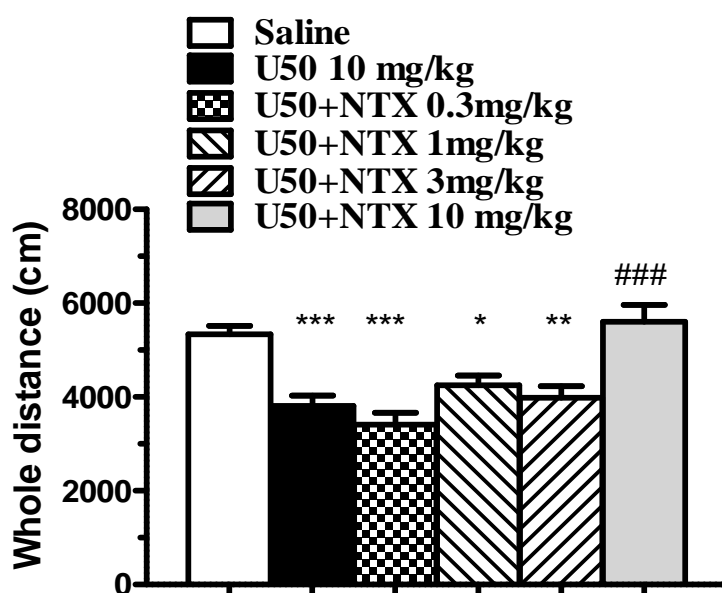
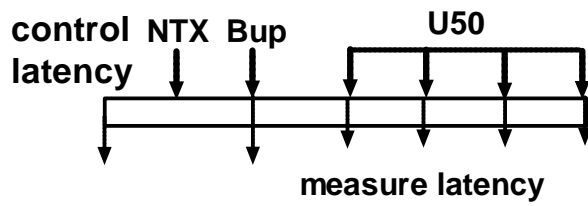

Figure 3.7. Locomotor activity in the open field in mice treated with U50,488 (U50 10 mg/kg) alone and in combination with naltrexone (NTX 0.3, 1,3 and 10 mg/kg). * $p < 0.05$, ** $p < 0.01$; *** $p < 0.001$ as compared to saline control. ### $p < 0.001$ as compared to U50. All values are mean \pm SEM, $n = 5$ per group.

To determine whether naltrexone alone or buprenorphine/naltrexone in combination have long acting κ -antagonist effects, their ability to block U50,488-induced antinociception was tested at 1, 8, 24 and 48 hours post-administration of antagonist (Figure 3.8), $n = 5$ per group). Two-way repeated measures mixed model analysis revealed that there was a significant interaction of Treatment*Time ($F_{(12,64)} = 12.25$, $p < 0.001$). At 1 hour, post-administration U50,488 produced an obvious antinociceptive effect that was significantly reduced by naltrexone alone, or in combination with buprenorphine (all p 's < 0.001 , compared to U50,488 alone). The κ -receptor blockade by naltrexone and by the combination buprenorphine/naltrexone was not evident at 24 and 48 hours post-administration of antagonist (Figure 3.8). At 8 hours post-administration, there was a reduction in the ability of naltrexone to block U50,488 induced antinociception, compared to 1 hour. Surprisingly, at 8 hours post administration of buprenorphine/naltrexone, U50,488 produced a clear potentiation in nociceptive effect ($p < 0.05$ compared to U50,488 alone). To investigate whether this potentiation is

mediated through the μ -opioid receptor, the irreversible μ -antagonist CCAM (3 mg/kg) was used. The ability of CCAM to block buprenorphine induced nociception was first confirmed. CCAM (3 mg/kg) was administered 24 hours before buprenorphine (1 mg/kg) and tail-withdrawal latency was measured at 1, 8, 24 and 48 hours post-administration of CCAM (Figure 3.9). CCAM (3 mg/kg) significantly reduced the antinociceptive effects of buprenorphine 1 mg/kg at all time intervals but not at 48 hours. In the second experiment, CCAM was injected 24 hours before the experiment began to investigate the potentiation of U50,488 effects at 8 hours. CCAM blocked the apparent potentiation ($p < 0.001$), suggesting that this potentiation results from μ -receptor activation by buprenorphine or its metabolites (Figure 3.10).



- U50 10mg/kg □ Bup 1mg/kg+NTX 1mg/kg+Saline
- ▲ Bup 1mg/kg+NTX 1mg/kg+U50
- ▼ NTX 1mg/kg+saline+U50

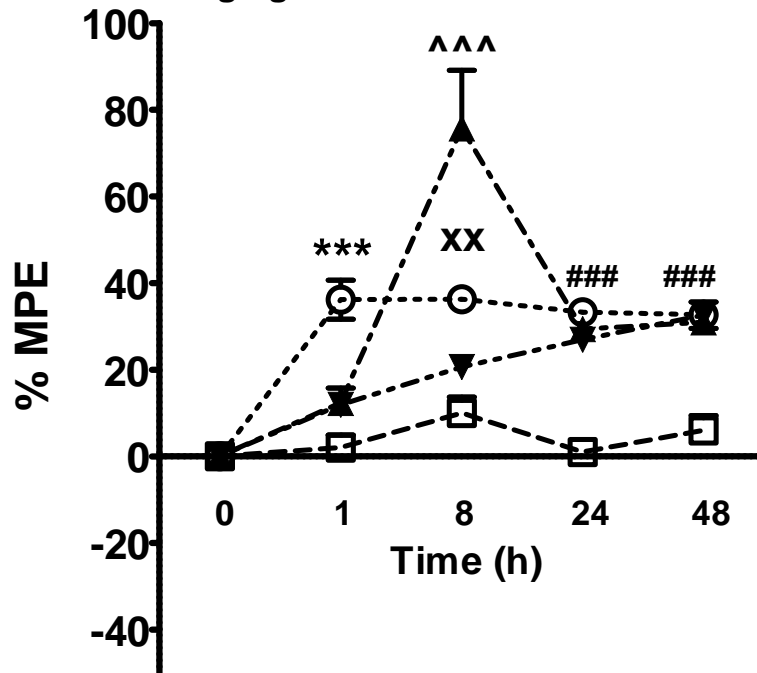

Figure 3.8. Duration of κ -antagonist effects of naltrexone (NTX) alone or naltrexone/buprenorphine combination. Significant blockade of U50,488 induced antinociception is evident at 1 h post-administration and reversed by 24 h. At 8h post-administration, the combination of buprenorphine/naltrexone, produced a significant potentiation of U50-488-induced antinociception (***) $p < 0.001$ compared to all other treatment groups, (^^^) $p < 0.001$ compared to all other treatment groups; (###) $p < 0.001$ for all treatment groups compared to NTX/Bup/saline controls; (xx) $p < 0.01$ compared to NTX/Bup/saline controls and compared to NTX/Saline/U50 group. Two-way repeated measures mixed model analysis was used. All values are mean \pm SEM, $n = 5$ per group.

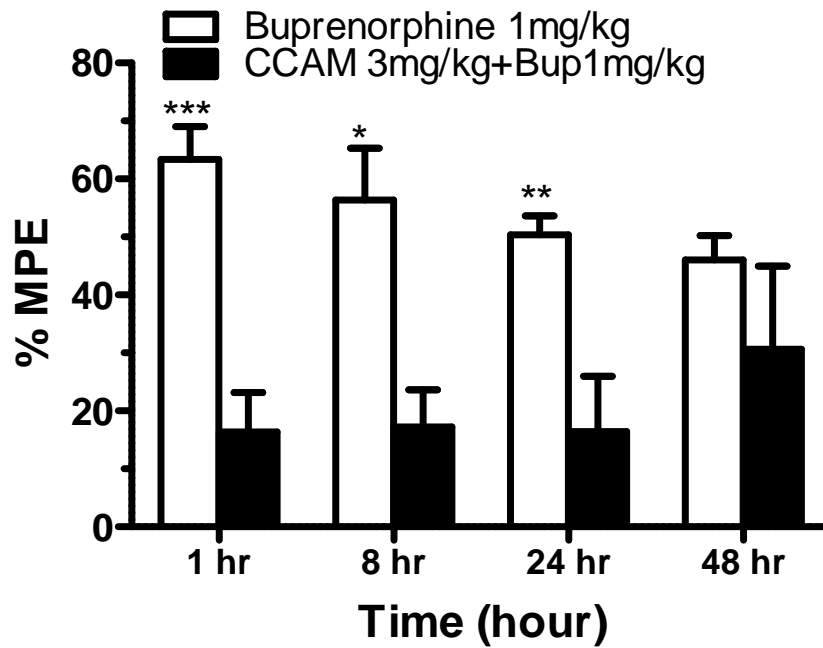

Figure 3.9. Antinociceptive effects of buprenorphine (1mg/kg) was blocked CCAM (3 mg/kg) in the mouse tail withdrawal assay. CCAM was given 24 hr before Bup. Bup was administered 1 hr before starting the measurement. Two-way repeated measures mixed model analysis was used. All values are mean \pm SEM, n= 5 per group. * p < 0.05, ** p < 0.01 and *** p < 0.001 as compared to CCAM+Bup.

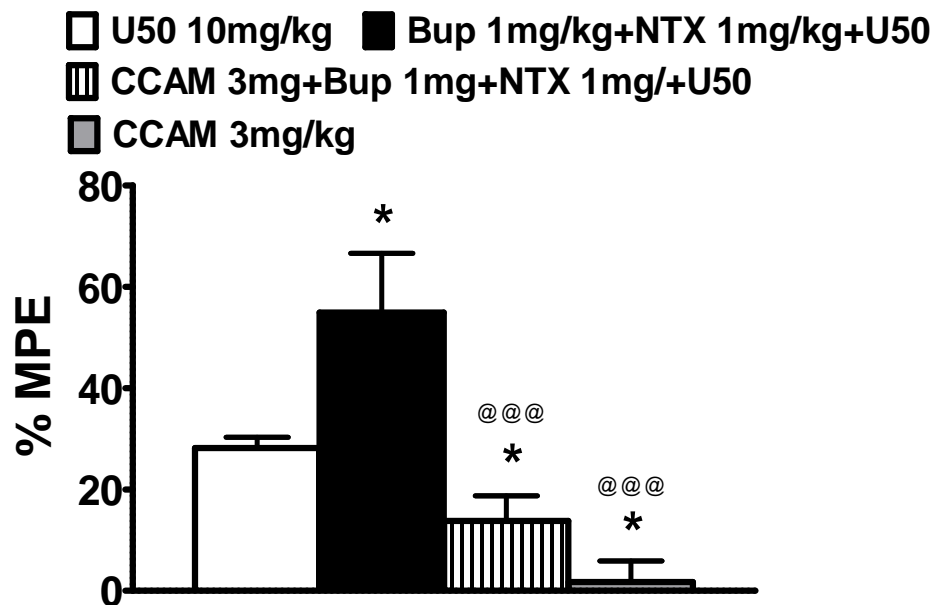

Figure 3.10. The irreversible μ -antagonist CCAM (3 mg/kg) administered 24 h before testing blocked the buprenorphine/ naltrexone (Bup/NTX) mediated potentiation of U50,488-induced antinociception at 8h post-administration (* p < 0.05 compared to U50 alone, @@@ p <0.001 as compared to Bup/NTX combination + U50 group). Two-way repeated measures mixed model analysis was used. All values are mean \pm SEM, n= 5 per group.

BU10119 at a dose of 0.3, 1 and 3 mg/kg showed no antinociceptive effects in the warm water tail withdrawal assay (figure 3.11A). Two-way repeated measures mixed model analysis revealed a significant interaction of Treatment*Time ($F_{(12,60)} = 19.35$, $p < 0.001$). Only buprenorphine (1mg/kg) produced a significant antinociceptive effect that peaked at 60 min post-administration ($p < 0.001$, compared to all injected groups) and returned to baseline after 240 min. BU10119 (1 and 3 mg/kg) and the irreversible μ -antagonist CCAM (3 mg/kg) (Figure 11C) were significantly able to block the antinociceptive effect of buprenorphine (1 mg/kg) and morphine (10 mg/kg) 60 min post-administration ($F_{(7,28)} = 18.68$, $p < 0.001$).

To determine the κ -antagonist properties of BU10119 (0.3, 1 and 3mg/kg) and its ability to block U50,488 induced antinociception, latency measurements were taken at 1, 8, 24 and 48 hours post-administration (Figure 3.11B, $n=5$ per group). Two-way repeated measures mixed model analysis showed that there was a significant interaction of Treatment*Time ($F_{(28,140)} = 5.46$, $p < 0.001$). U50,488 produced a pronounced antinociceptive effect that was significantly blocked by BU10119 (1 and 3 mg/kg) at 1, 8 and 24 h post-administration ($p < 0.001$). Moreover, norBNI (1 mg/kg) was able to block U50,488 analgesic activity at all-time intervals (all p 's < 0.001 , compared to U50,488). Moreover, BU10119 at all doses was without a significant effect on locomotor activity ($p > 0.05$) (Figure 11D).

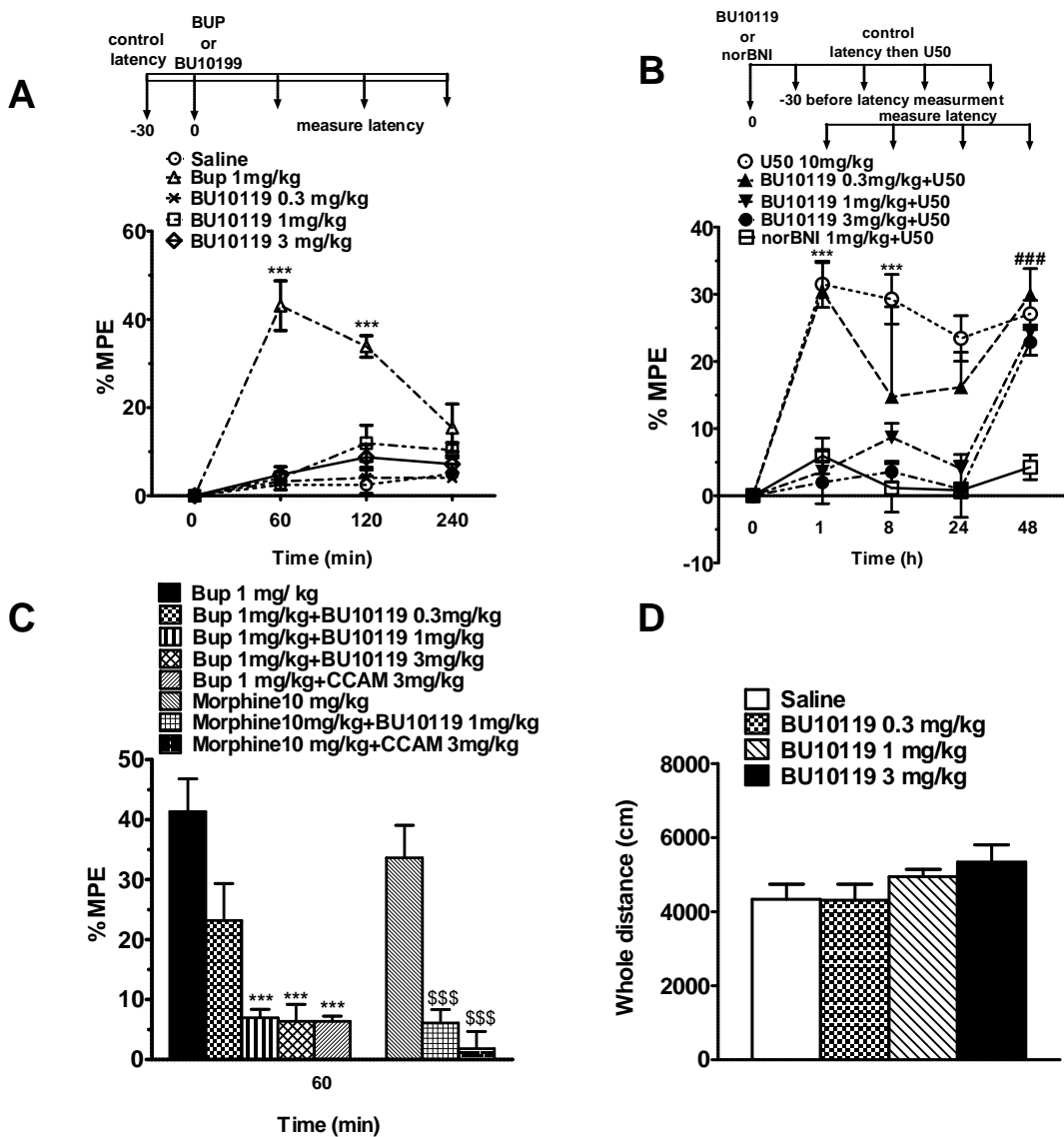

Figure 3.11. Antinociceptive effects of buprenorphine (Bup, 1mg/kg) and U50,488 (U50, 10 mg/kg) are blocked by BU10119 in the mouse tail withdrawal assay. The time course of the experiments is shown (A,B). Locomotor activity in the open field in mice treated with BU10119 (0.3, 1 and 3mg/kg) (D). (A) Only buprenorphine (1 mg/kg) was able to increase latency time in the mouse tail withdrawal assay. (** $p < 0.001$ as compared between Bup (1 mg/kg) and all groups). (B) Antinociceptive effects of U50,488 (10 mg/kg) was blocked by BU10119 (1 and 3 mg/kg) and norBNI (1 mg/kg). (** $p < 0.001$ as compared to BU10119 (1 and 3 mg/kg) and norBNI (1mg/kg)). (### $p < 0.001$ as compared between all group and norBNI (1mg/kg)). (C) BU10119 (1 mg/kg) blocked buprenorphine and morphine-induced antinociception (** $p < 0.001$ compared to BUP; \$\$\$ $p < 0.001$ to morphine). The irreversible μ -antagonist CCAM (3 mg/kg) administered 24 h before testing blocked buprenorphine and morphine-induced antinociception at 60 min post-administration (** $p < 0.001$ compared to BUP; \$\$\$ $p < 0.001$ to morphine). Two-way repeated measures mixed model analysis was used. All values are mean \pm SEM, $n = 5$ per group.

3.6. Discussion:

Buprenorphine has a complex opioid receptor pharmacology; it is a partial agonist at μ and ORL-1 receptors and an antagonist at κ and δ -receptors (Lutfy and Cowan, 2004). Buprenorphine is widely used for its analgesic properties and for the treatment of opioid dependency (Cowan, 1995; Rothman et al., 1995; Preston and Jasinski, 1991; Cowan and Lewis, 1995; Lutfy et al., 2003). Despite the fact that buprenorphine is used for the treatment of opioid dependency it might carry a risk of abuse liability and dependence because it is a partial agonist at μ -receptors (Mello et al., 1988). However, it has been shown that naltrexone, a non-selective opioid antagonist, could discourage and reduce such abuse (Gerra et al., 2006). Here we have established for the first time doses of buprenorphine and naltrexone that, when combined, produce functional κ -receptor antagonism in mice. Systemic administration of buprenorphine/naltrexone combination at a dose of (1 mg/kg) is functional short-acting κ -receptor antagonist in the tail withdrawal test in adult CD-1 male mice. Also, BU10119 (1 mg/kg) is a κ -receptor antagonist with a rapid onset and a duration of action not more than 24 hours. Furthermore, the combination regimen and BU10119 were not sedative being without significant locomotor effects in the open field test at the doses used.

In this chapter, buprenorphine (1 mg/kg) significantly increased the %MPE in tail-flick that was not enhanced at 3 mg/kg. These results are in agreement with previous studies that reported that the analgesic properties of buprenorphine at higher doses may reach a plateau level without a maximal response and the dose response curve is sometimes bell-shaped, in nociceptive assays, depending upon the intensity and nature of the noxious stimulus (Cowan et al., 1977; Dum et al., 1981; Lizasoain et al., 1991; Lutfy and Cowan, 2004; Ide et al., 2004; Lutfy et al., 2003). The antinociceptive effects of buprenorphine result from activation of μ -receptors. Lutfy et al (2003) have shown that buprenorphine has no antinociceptive effect in μ -receptor knockout mice. Moreover, our data agree with studies that have shown that the irreversible μ -antagonist, CCAM was able to block

the analgesic properties of both morphine and buprenorphine (Broadbear et al., 2000; Kögel et al., 2005). In our study we injected CCAM 24 hours before any measurement because CCAM was reported in radioligand binding assays to interact with all μ , κ and δ -receptors. However, after 8 hours or more of injection it becomes an irreversible selective μ -receptor antagonist (Chan et al., 1995; Zernig et al., 1996). Moreover, Lutfy et al (2003) reported that the antinociceptive effect of buprenorphine is significantly enhanced in ORL-1 receptor knock-out mice. In addition, they reported that the antinociceptive effect of buprenorphine was enhanced by J-113397, an ORL-1 receptor antagonist (Lutfy et al., 2003). In the locomotor studies, it has been reported that buprenorphine (0.50 to 5.0 mg/kg) causes an increase in locomotion in mice (Jackson et al., 1993). However, in this study, buprenorphine at the dose of 1mg/kg alone or in combination with naltrexone were neither hyperactive nor sedative in adult CD-1 male mice and this is an agreement with a previous study (Filibeck et al., 1981). This controversy could be explained by the different effect of the drug on different strains.

In this chapter, naltrexone pretreatment (1 and 3 mg/kg) was capable of blocking buprenorphine antinociception and that was in agreement with a previous study in mice (Kögel et al., 2005). Moreover, the antinociceptive effects of U50, 488 (10 mg/kg) were significantly reduced by pretreatment with naltrexone (1 and 3 mg/kg) and this is an agreement with previous studies (Dum and Herz, 1981; Stevens et al., 1994). In open field study, U50, 488 (10 mg/kg) significantly reduced locomotion in mice. Similar effects were reported by Paris et al (2011) and von et al (1983). Since U50, 488 is a highly specific for the κ -receptor (von et al., 1983) it is likely that this effect is mediated by κ -receptors. Von et al (1983) reported that U50, 488 at a dose of 10 mg/kg caused a significant hypoactivity in mice that was reversed by naloxone 10 mg/kg. In this study, naltrexone pretreatment with 10 mg/kg was the only dose able to antagonise the hypoactivity of U50, 488.

In this chapter, we have shown that BU10119 have no analgesic properties in tail flick assay. Also, it was able to suppress the increase in %MPE of both morphine and buprenorphine and this effect may be mediated through μ -receptor antagonism. These results are in consistence with rat vas deferens assay which found that BU10119 was a reversible competitive antagonist at μ -opioid receptors with a pA2 value of 10.08 (9.84-10.31) (Ridzwan, 2102). Moreover, BU10119 showed κ -receptor antagonist activity by blocking the analgesic effect of U50,488 and this result is with consistent with mice vas deferens assay which found that BU10119 acts as a κ -receptor antagonist with an average pA2 value of 9.83 (9.08-10.58) (Ridzwan, 2102) (see table 3.1). Indeed, these effects were not mediated through general sedation because BU10119 was neither hyperactive nor sedative in locomotor activity test and that BU10119 is mixed μ/κ -receptor antagonist.

Compound	κ -receptor	μ -receptor	ORL-1	δ -receptor
Buprenorphine	0 \pm 6% (Ke = 0.14 \pm 0.06 nM)	20 \pm 6% (EC50: 0.7 \pm 0.3nM)	39 \pm 12% (EC50: 1480 \pm 980 nM)	7 \pm 3%
BU10119	-2 \pm 1% (Ke = 0.09 \pm 0.04 nM)	2 \pm 4% (Ke = 0.28 \pm 0.04 nM)	56 \pm 1% (EC50: 147 \pm 33 nM)	0 \pm 4%

Table 3.1. Table shows maximal stimulation of [35S] GTP γ S binding to opioid and ORL-1 receptors. Data are taken from Cueva et al. 2015.

It has been reported that the existing selective κ -receptors antagonists, such as norBNI and GNTI have very long lasting effects in vivo (Beguin and Cohen, 2009; Carroll and Carlezon, 2013). For example, one injection of norBNI has peak κ - receptor antagonist effects starting at about 24 hours post-administration, continuing at high levels for 7–10 days and returning to control levels after 3–4 weeks or persisting for months (Endoh et al., 1992; Horan et al., 1992). This limits in vivo behavioural testing and potentially clinical trials if the blockade of κ -receptors may not be easily reversed. In this study, buprenorphine/naltrexone combination and BU10119

were demonstrated to have shorter durations of κ -receptor antagonist action in comparison to norBNI, with potencies similar to that of norBNI, in blocking κ -receptor agonist-induced antinociception.

In summary, here we demonstrated that the buprenorphine/naltrexone (1 mg/kg) combination are mixed μ/κ -receptor antagonist and a functional short acting κ -receptor antagonist. Moreover, we established that the BU10119 (1 mg/kg) is mixed μ/κ -receptor antagonist with a rapid onset and a duration of action, not more than 24 hours. Furthermore, the combination regimen and BU10119 were neither hyperactive nor sedative in locomotor activity assay and these actions are not mediated throughout a general sedation.

Chapter 4

**Establishing the rewarding properties of combination
buprenorphine/naltrexone and single compound
BU10119 in conditioned place preference (CPP) task**

4.1. Introduction

Opioid compounds, both prescription analgesics and drugs like heroin, are associated with dependence and addiction. Addiction to opioid analgesics is a growing problem worldwide and can cause serious health side effects and can lead to deaths due to overdose (Fields, 2011; Hall et al., 2008). In the general population, in 2011/12 in England, there were 8.4 opiate users per 1,000 and 155,000 people were treated for opioid addiction (Strang et al., 2006). Indeed, almost one in nine deaths recorded among people in their 20s and 30s in Wales and England in 2014 were related to drug addiction (White and Hamilton, 2016). Drug addiction can be defined as a chronic relapsing disorder that is characterized by a compulsive drug use regardless of severe negative consequences or loss of control over drug use which can lead to long-lasting changes in certain brain regions (Hyman et al., 2006).

The exact mechanism of opioid addiction is still unclear. However, numerous studies have been made in the past two decades to identify the brain regions and the cellular and molecular mechanism that mediate addiction (Hyman et al., 2006; Wang et al., 2012). The mesolimbic pathway, in particular, was reported as the key part in reward process. This pathway originates with dopaminergic cell bodies in the VTA, a dopamine-rich nucleus located in the ventral portion of the midbrain. These dopaminergic axons project and primarily end in the NAc in the ventral striatum, but also extend into the Amy, and lateral Hip (Adinoff, 2004). It was documented that the analgesic and rewarding properties of opioids depend on its actions at the μ -receptor (Sora et al., 1997; Zhang et al., 2009). Since the majority of μ -receptors in the VTA are localized to the GABA cells (Dilts and Kalivas, 1989; Garzon and Pickel, 2001), it has been proposed that μ -receptor activation produces dopamine release via disinhibition. Opioid binding to VTA GABA cells produces hyperpolarization of these neurons (Johnson and North, 1992) and causes the releases of dopamine and accounts for the rewarding properties of opioid (Ting-A-Kee and van der Kooy, 2012). Indeed, systemic administration of μ -receptor agonist causes a conditioned place

preference (CPP), in rats and mice, which can be blocked by injection of μ -receptor selective antagonists into the VTA or genetic knockdown of μ -opioid receptor (Olmstead and Franklin, 1997, Zhang et al., 2009). Moreover, there are other sites that μ -receptor agonists, such as morphine, may act on to produce self-administration in mice which include the lateral and medial HL, NAc shell and the mesencephalic central gray area (David and Cazala, 1994). Also, it was reported that naltrexone decreased ethanol consumption in human alcoholics (Volpicelli et al., 1992) and was effective in the treatment of heroin dependence (Callahan et al., 1980; Gerra et al., 2006). On the other hand, it has been reported κ -receptor stimulation reduces the release of DA and leads to aversive condition (Spanagel and Shippenberg, 1990; Adinoff, 2004; Lüscher and Malenka, 2011).

Buprenorphine acts as a partial μ -receptor agonist and a κ -receptor antagonist with additional nociception/orphanin FQ receptor (NOP-receptor, also known as ORL1) partial agonist activity (Huang et al., 2001; Lutfy and Cowan, 2004). It has been used as an alternative to methadone in the treatment of opioid addiction (Maremmani and Gerra, 2010). However, buprenorphine treatment carries a risk of abuse liability and dependence. Naltrexone, a relatively non-selective opioid receptor antagonist, is licensed as an abstinence promoter for the treatment of alcohol addiction (Rosner et al., 2010). Combining naltrexone with buprenorphine could reduce the potential abuse liability of buprenorphine activating μ -receptors, while enhancing κ -receptor antagonist actions. Naltrexone has been reported to have some aversive side effects and it is important to make sure that the combination is not rewarding nor aversive. Also, BU10119 is a novel compound, which resemble the combination pharmacology, needs to be assessed for rewarding and aversive properties.

The conditioned place preference (CPP) task is one of the most popular models to study motivational and the reinforcing effects of opioids (Tzschentke, 2007). CPP is a learned behavior reported in many animal species and humans. CPP take place when a subject becomes to prefer one

location more than others because the preferred location has been paired previously with the motivational or the reinforcing events (Bardo and Bevins, 2000; Tzschentke, 2007). Indeed, it has been reported that amphetamine users develop a CPP for where they consumed the drug (Childs and Wit, 2009). The CPP procedure depends on a neutral stimulus which is paired repeatedly with an unconditioned stimulus, such as food (Spyraki et al., 1982), sweet fluid (Agmo and Marroquin, 1997) and drug (Tzschentke, 2007; Olmstead and Franklin, 1997), that elicits a response prior to conditioning which is called unconditioned response. At the end of the experiment and pairings the neutral stimulus will produce responses similar to the unconditioned response. The neutral environmental cues become associated with the motivational or the reinforcing properties of the unconditioned stimulus leading to either avoidance or approach of the environment (Huston et al., 2013).

The apparatus used in CPP is composed of two compartments and they are designed differently so that a mouse or rat can distinguish between them. The apparatus consisted of a box with two compartments joined by a removable partition that allowed animals to explore freely or be restricted to a particular compartment (Ide et al., 2004). CPP procedure composed of three stages which include habituation, conditioning and preference testing (Cunningham et al., 2006). In the habituation stage, the animal is given a chance to explore the two compartments freely and that is performed to reduce the effects of novelty on animals. In the conditioning stage, the animals will be given the unconditioned stimulus each other day and will be paired to one compartment. In the preference testing stage, the animal is allowed to access freely to the two compartments and the time spent in each chamber is recorded. The CPP method is simple, sensitive to low doses of drugs, not expensive, allows both aversive and rewarding effects to be measured and different species can be used. Also, it has been used extensively to show the rewarding effects of opioids in mice (Tzschentke, 2007; Huston et al., 2013).

4.2. Chapter aims

In this chapter, we have tested whether naltrexone at 1mg/kg blocks any rewarding properties of buprenorphine. This dose of naltrexone has been shown to block buprenorphine's analgesic properties mediated at μ -receptors and U50,488 induced analgesia without any sedative effects (Chapter 3). Also, BU10119 at a dose of 1 mg/kg was investigated for any rewarding properties in CPP.

4.3 Methods

4.3.1 Conditioned place preference (CPP)

Place preference conditioning was conducted in a CPP chamber with an auto monitoring system (Ethovision XT version 8.0). CPP was assessed by three phases (habituation, conditioning, and preference testing phase). The apparatus (UGO Basile) consisted of a box with two compartments (16×15 cm/compartment) joined by a removable partition that allowed mice to explore freely or be restricted to a particular compartment. The two compartments differed in appearance and texture: one compartment had black walls and a grey floor with round 2 mm holes, while the other compartment had walls with vertical black and white stripes and a grey floor with 4×4 mm square holes (Figure 4.1). Experiments were performed between 09:00 hours and 16:00 hours under dim light (approximately 15 lux). During all test sessions, the time each mouse spent in each compartment was recorded using tracking software. Mice were randomly assigned to treatment groups and the pairing was counterbalanced (i.e. within each treatment group equal numbers of mice were always drug-paired to each compartment type). On days 1 and 2 mice were habituated to the entire chamber for 15 minutes (one session/day). On days 3–8 mice were conditioned (40 minutes) to one of the two compartments, and daily sessions alternated between drug treatment and saline (In all treatment groups mice received both drug and saline) (Figure 4.2). Mice were given buprenorphine (0.3 or 1 mg/kg), BU10119 (1mg/kg) or saline (0.9 % w/v). Naltrexone (1 or 3 mg/kg) was injected 10 min before the injection of buprenorphine or saline. CCAM (3 mg/kg) was injected and mice immediately returned to the home cage 24 hr before conditioning. In experiments with norBNI (10 mg/kg) mice were injected in the 2nd and 5th and immediately return to home cage and 10 minutes between norBNI and CCAM injection were adopted. After buprenorphine injection, the mice were transferred directly to the place preference box and at the end mice were returned to their home cage.

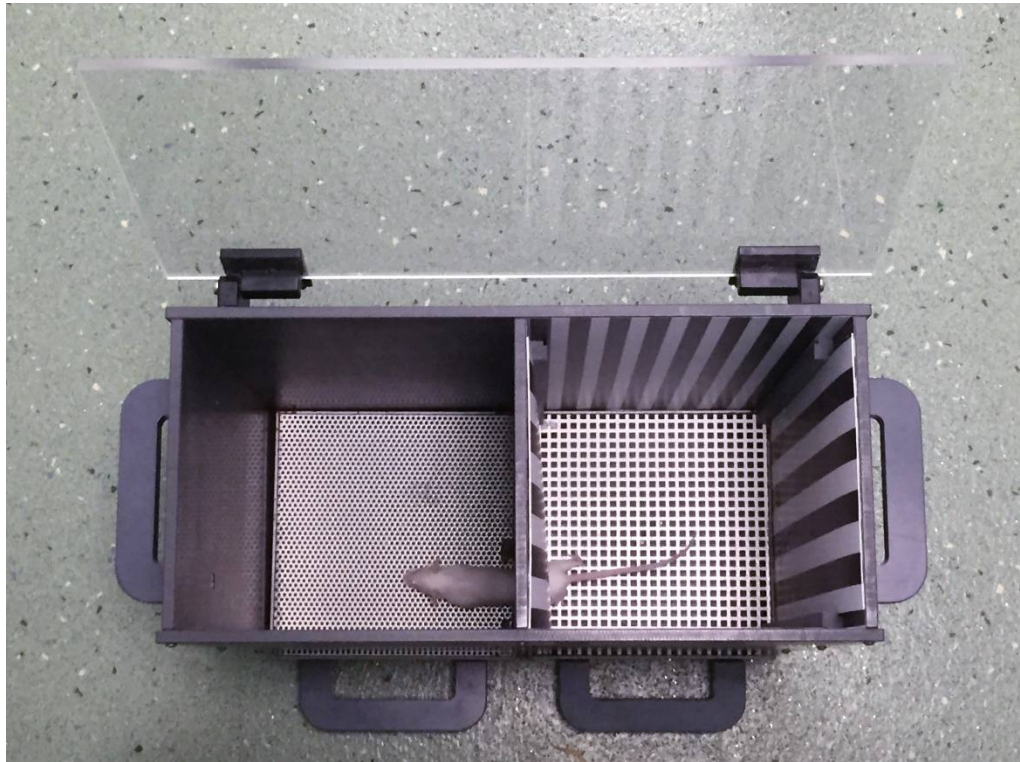

Figure 4.1 Photo of the conditioned place preference (CPP) chamber.

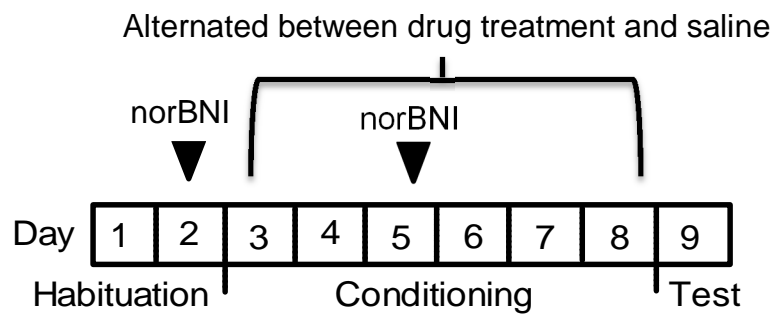

Figure 4.2. The time line of the CPP experimental design. Naltrexone (NTX)(1 or 3 mg/kg) was injected 10 min before the injection of buprenorphine or saline. CCAM (3 mg/kg) was injected 24 hr before conditioning and 10 minutes between norBNI and CCAM injection were adopted. NorBNI (10 mg/kg) was injected in the 2nd and 5th day.

Chamber floors and trays were removed and cleaned with ethanol 70% and left for 5 minutes for ethanol to evaporate before the next trial. On day 9, mice were not injected with saline or drugs. In a free-to-explore test, lasting 15 minutes, mice had free access to both compartments and their preference was determined by recording the time spent in the drug-paired chamber.

4.4 Results

4.4.1. Establishing the rewarding properties of combination buprenorphine/naltrexone and single compound BU10119 in conditioned place preference (CPP) task

The rewarding or aversive properties of BU10119 (1mg/kg), naltrexone (1 and 3 mg/kg), CCAM (3mg/kg) and norBNI (10 mg/kg) was investigated in the CPP task and buprenorphine (0.3 and 1 mg/kg) and morphine were used as positive controls. One way ANOVA revealed that mice receiving 1 mg/kg buprenorphine exhibited significant conditioned place preference, evident as a significantly increased time spent in the drug-paired compartment of the CPP chamber, compared to pre-conditioning ($F_{(5,42)} = 2.84, p < 0.027, n = 8, p = 0.05$) (Figure 4.3). However, co-administration of 1 and 3 mg/kg naltrexone completely blocked the conditioned place preference elicited by buprenorphine. While not significant, there was a trend for 3 mg/kg naltrexone to increase the time spent in the saline-paired compartment compared with preconditioning, suggesting that naltrexone at this dose may be eliciting an aversive response.

In the second experiment we investigated the effects of BU10119 (1mg/kg), higher dose of naltrexone (10 mg/kg) and buprenorphine (1 mg/kg) was included as a positive control (Figure 4.4). One-way ANOVA revealed a significant effect of Treatment on the time spent in a drug-paired compartment in the CPP task ($F_{(3,34)} = 15.16, p < 0.001$) (Figure 4.4). Post hoc comparisons to saline treated controls revealed that buprenorphine (1 mg/kg) increased the time spent in the drug-paired compartment ($p < 0.05$). In contrast, naltrexone (10 mg/kg) increased the time spent in the saline-paired compartment ($p < 0.01$). Naltrexone at higher doses increased the time spent in the saline-paired compartment compared with preconditioning, suggesting that naltrexone at a higher dose is eliciting an aversive response. Also, there was a non-significant increase in the time spent in the drug-paired compartment of BU10119 ($p = 0.058$).

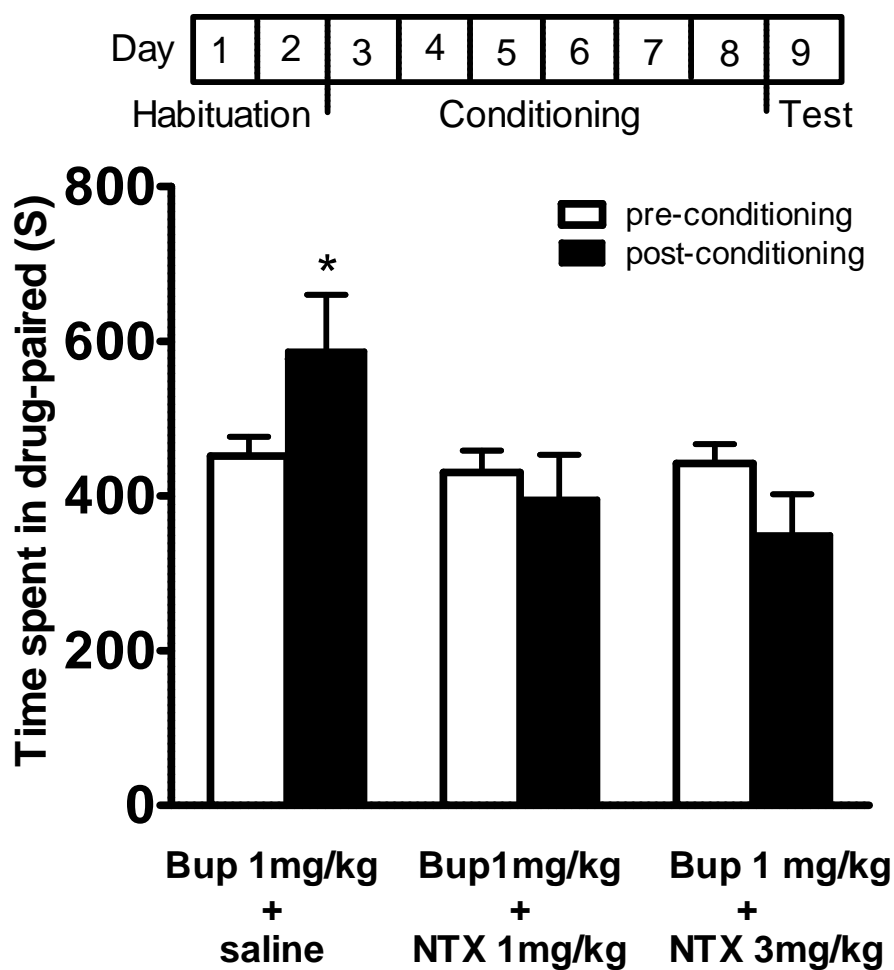

Figure 4.3. Conditioned place preference to buprenorphine (Bup, 1 mg/kg) in adult male CD1 mice, in the presence and absence of naltrexone (NTX) (1 and 3 mg/kg). In a 900 second test, animals in all treatment groups did not show a preference for either chamber during habituation (pre-conditioning). After 6 days of conditioning, buprenorphine significantly increased the time spent in the drug-paired chamber. The analysis was done by one-way ANOVA followed Unadjusted Least Significant Difference (ULSD) post hoc test. Values are mean \pm SEM, $n=8$ per group. * $p=0.05$ vs pre-condition group.

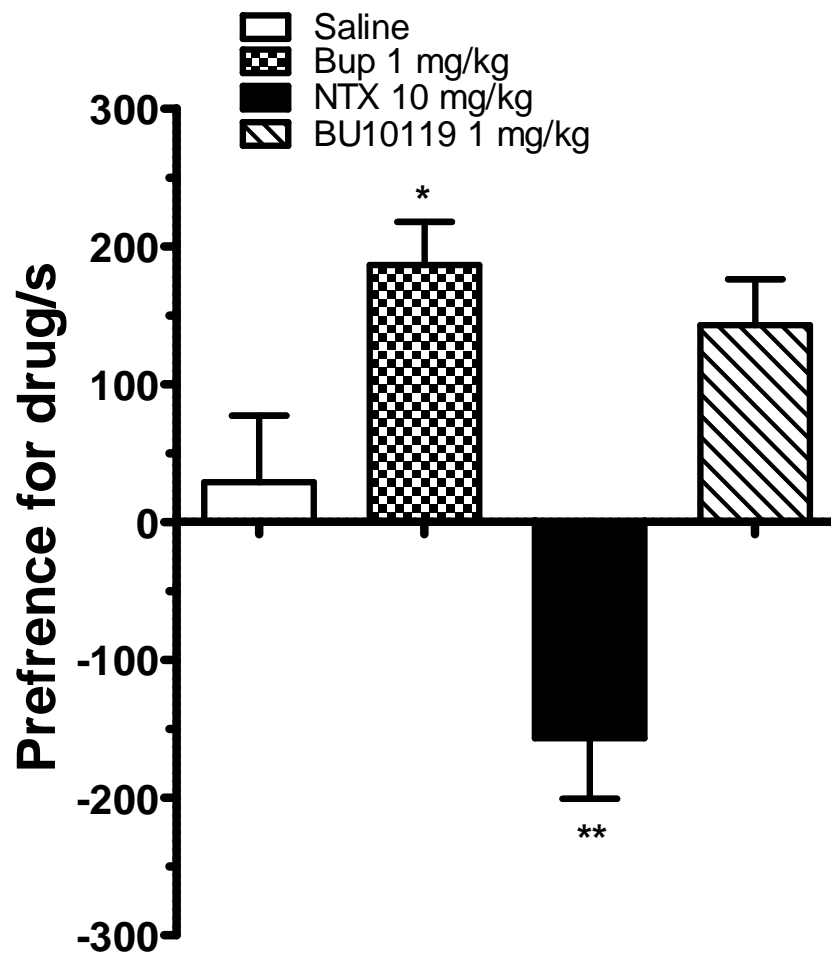

Figure 4.4. Effects of buprenorphine (Bup), naltrexone (NTX) (10 mg/kg) and BU10119 (1 mg/kg) in conditioned place preference assay in adult male CD1 mice. Data are presented as preference for the drug (= time spent in the drug-paired side during test minus time spent in the drug-paired side at baseline (Naltrexone and BU10119), n=9 (Saline, Buprenorphine). The analysis was done by one-way ANOVA followed Unadjusted Least Significant Difference (ULSD)) post hoc test. Values are mean \pm SEM, n=10. *p<0.05 and **p<0.01 as compared to saline.

To investigate whether the increase in time spent in the drug-paired chamber of BU10119 and buprenorphine is mediated through the μ -receptor, the irreversible μ -receptor antagonist CCAM (3mg/kg) was used (Figure 4.5). The selection of CCAM dose was based on our previous tail withdrawal results (Chapter 3). One-way ANOVA revealed a significant effect of Treatment on the conditioned place preference ($F_{(5,48)} = 6.78, p < 0.0001$). However, BU10119 showed a non-significant increase in time spent in the drug-paired compartment, compared to saline-treated groups ($p < 0.0782$). Moreover, CCAM (3 mg/kg) was able to reduce the time spent in the drug-paired compartment to control level for BU10119 (1 mg/kg) treated mice ($p = 0.9$ as compared to saline control). Interestingly, CCAM (3 mg/kg) failed to block or to reduce the significant increase in time spent of buprenorphine (1 mg/kg) in the drug-paired compartment ($p < 0.9139$ as compared to buprenorphine alone, Figure 4.5). Importantly, CCAM (3mg/kg) alone was not rewarding or aversive ($p < 0.9139$). In a subsequent experiment, CCAM (3mg/kg) was able to block the rewarding effects of morphine (10mg/kg) (unpaired Student t-test, $p < 0.0119, n = 8$) (Figure 4.6) but not of buprenorphine (1 mg/kg) ($p < 0.3838$). The ability of CCAM to block the rewarding effects of buprenorphine at a lower dose of 0.3 mg/kg was also investigated. This lower dose of buprenorphine increased the time spent in the drug-paired side of the CPP apparatus compared to saline-treated groups (one-way ANOVA ($F_{(2,25)} = 24.45, p < 0.0001, n = 9-10$) (Figure 4.7). However, CCAM (3mg/kg) failed to block the rewarding properties of 0.3 mg/kg buprenorphine ($p = 0.7811$).

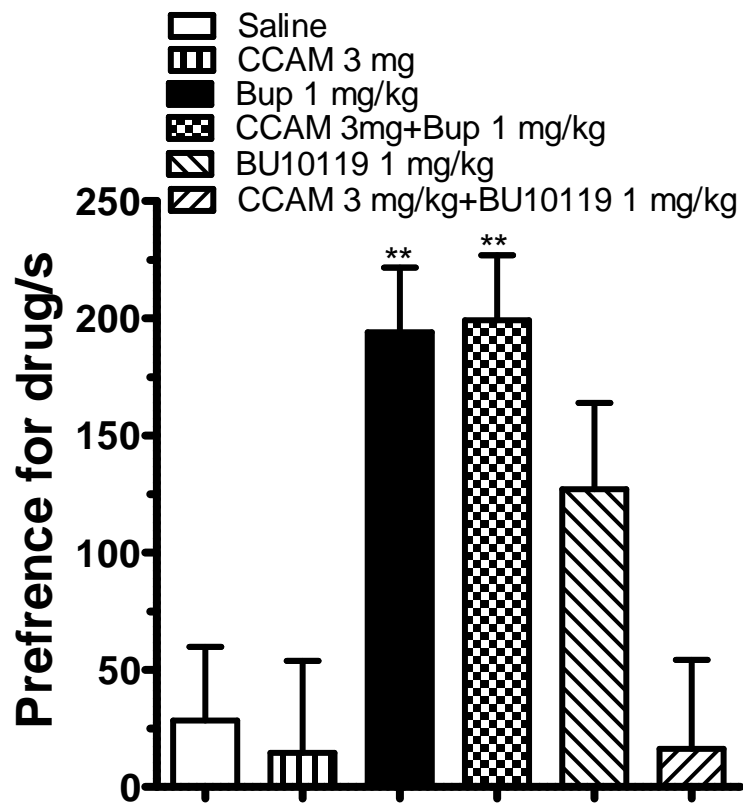

Figure 4.5. Effects of buprenorphine (Bup) (1 mg/kg), BU10119 (1 mg/kg) and CCAM (3 mg/kg) alone or in combination in conditioned place preference assay in adult male CD1 mice. Data are presented as preference for the drug (= time spent in drug-paired side during test minus time spent in drug-paired side at baseline). The analysis was done by one-way ANOVA followed Unadjusted Least Significant Difference (ULSD) post hoc test. Values are mean \pm SEM, SEM, n=9. **p<0.01 as compared to saline.

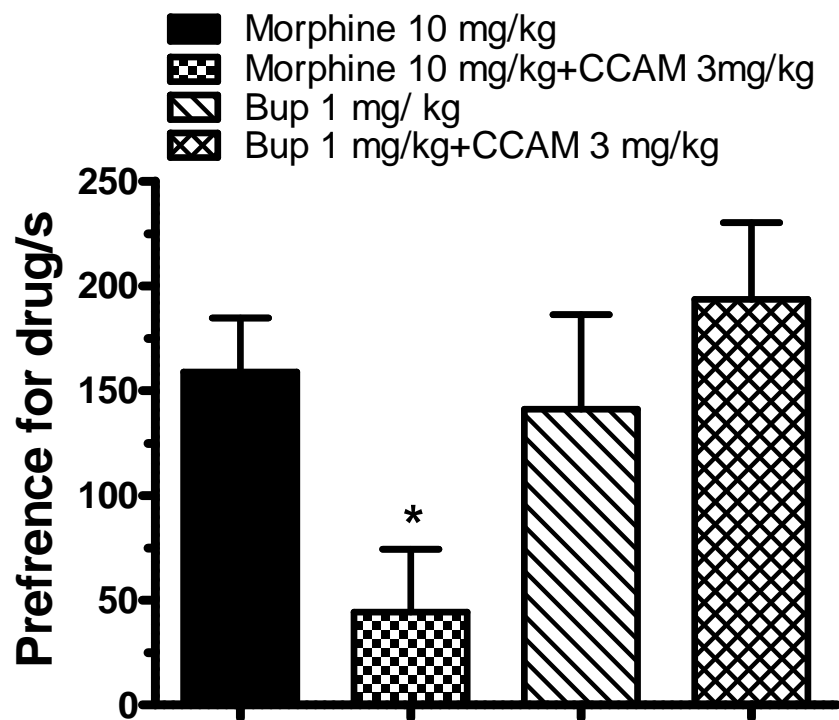

Figure 4.6. Effects of morphine (10 mg/kg), buprenorphine (Bup) (1mg/kg) alone or in combination with CCAM (3 mg/kg) in conditioned place preference assay in adult male CD1 mice. CCAM (3 mg/kg) was administered 24 hr before morphine and Bup. Data are presented as preference for the drug (= time spent in drug-paired side during test minus time spent in drug-paired side at baseline) \pm SEM, n=8. The analysis was done by unpaired Student t-test. * p <0.05 as compared to morphine.

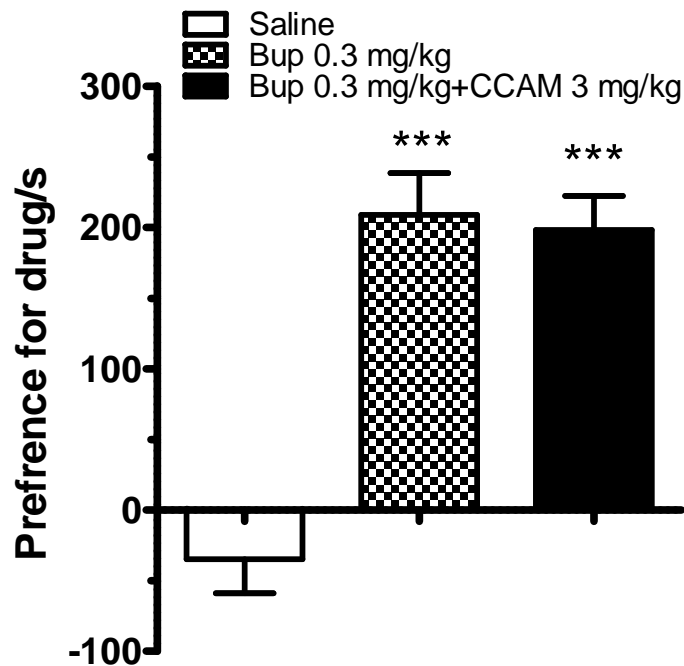

Figure 4.7. Effects of buprenorphine (Bup) (0.3 mg/kg) alone and in combination with CCAM (3 mg/kg) in conditioned place preference assay in adult male CD1 mice. CCAM (3 mg/kg) was administered 24 hr before Bup. Data are presented as preference for the drug (= time spent in the drug-paired side during test minus time spent in drug-paired side at baseline). The analysis was done by 1-way ANOVA followed Unadjusted Least Significant Difference (ULSD) post hoc test. Values are mean \pm SEM, n=10 (Bup), n=9 (saline and Bup with CCAM). ***p<001 as compared to saline treated group.

To determine whether this apparent rewarding effect by buprenorphine (0.3 mg/kg) may be mediated through the κ -receptor, CCAM (3 mg/kg) and the κ -receptor antagonist norBNI (10 mg/kg) were used alone or in combination (Figure 4.8). One-way ANOVA revealed a significant effect of Treatment on the time spent in the drug-paired compartment ($F_{(7,64)}=7.25$, $p<0.0001$). Post hoc analysis showed that CCAM (3mg/kg) ($p<0.725$) and norBNI (10 mg/kg) ($p<0.725$), alone and in combination ($p<0.684$), were neither rewarding nor aversive as compared to saline treated group. Also, neither CCAM (3mg/kg) nor norBNI (10 mg/kg) ($p<0.3$), alone or in combination ($p<0.725$), were able to block the conditioned place preference induced by buprenorphine (0.3 mg/kg). Interestingly, there was a significant increase in the time spent in the drug-paired compartment of the CCAM/buprenorphine combination as compared to buprenorphine (0.3 mg/kg) ($p<0.0325$).

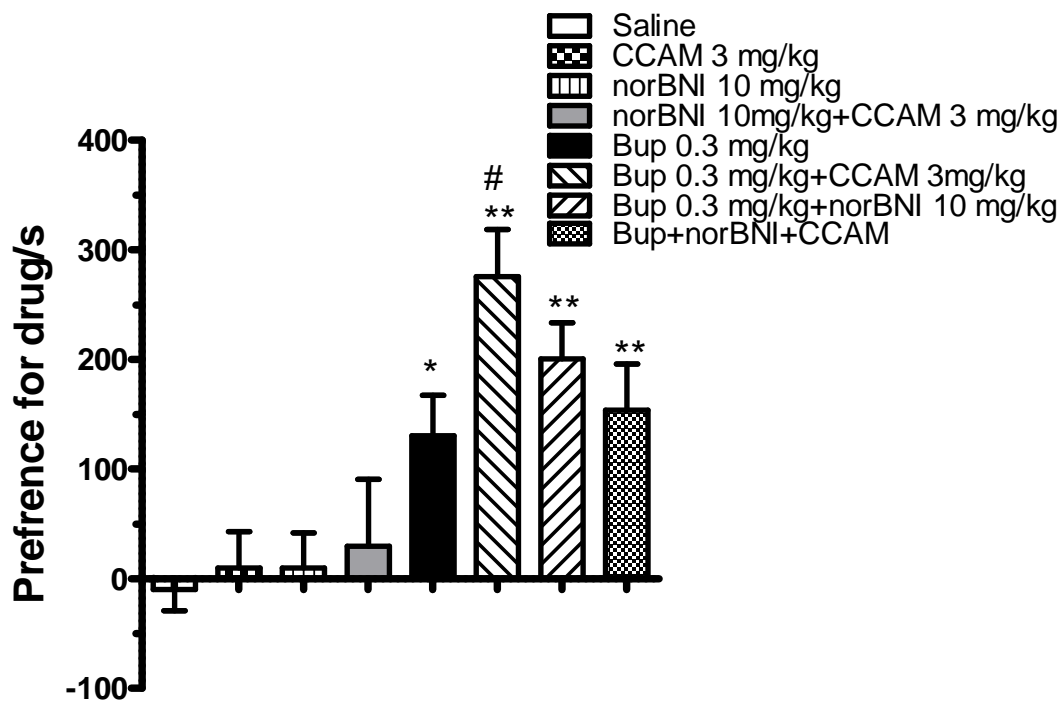

Figure 4.8. Effects of buprenorphine (Bup) (0.3 mg/kg), CCAM (3 mg/kg), norBNI (10 mg/kg) alone and in combination in conditioned place preference assay. Data are presented as a preference for the drug (= time spent in the drug-paired side during test minus time spent in the drug-paired side at baseline). The analysis was done by one-way ANOVA followed Unadjusted Least Significant Difference (ULSD) post hoc test. Values are mean \pm SEM, n=9. $p^* < 0.05$ and $p^{**} < 0.01$ as compared to saline. # $p < 0.05$ as compared to buprenorphine (0.3 mg/kg).

4.5. Discussion

In this study buprenorphine (0.3 and 1 mg/kg) was rewarding in CPP and that is in agreement with previous studies in mice (Ide et al., 2004) and rats (Tzschentke, 2004). Also, naltrexone (1 and 3 mg/kg) was able to block this effect and that was in agreement with previously published findings in rats (Cordery et al., 2014). Furthermore, it was established for the first time that the combination dose of buprenorphine (1 mg/kg) with naltrexone (1 mg/kg) is neither rewarding nor aversive in the CPP paradigm in adult CD-1 male mice.

Naltrexone is non-selective antagonist at the μ , κ -receptor and to a lesser extent at the δ -receptor (Giordano and Cicero, 1990; Takemori et al., 1988; Ghirmai et al., 2008). In this chapter, there was a trend for naltrexone to increase the time spent in the saline-paired compartment compared with preconditioning, which was significant when the dose was increased to 10 mg/kg. This suggests that naltrexone at higher doses may be eliciting an aversive response. Indeed, naltrexone alone at a dose of 10 mg/kg was aversive in this study and this effect may be mediated by μ -opioid antagonism (Mucha et al., 1985; Parker and Rennie, 1992). Indeed, in one study naltrexone was reported to have aversive effects. It was reported that a single 50-mg dose of naltrexone led to a range of unpleasant symptoms, including dysphoria (Mendelson et al., 1978). In another study, naltrexone treatment did not lead to an increase in depressive symptoms. However, there was a trend for the symptoms depression to be lower while on naltrexone. Moreover, participants adherent to naltrexone treatment had less depressive symptoms than those not adherent to naltrexone treatment (Dean et al., 2006).

In this chapter, the surprising result that the irreversible μ -receptor antagonist CCAM did not block place preference induced by buprenorphine. CCAM (3 mg/kg) was able to block the rewarding properties of morphine (10 mg/kg) and this clearly shows that the morphine-induced increase in the time spent in the drug-paired compartment was mediated through the μ -receptor.

This is consistent with Matthes et al (1996) which reported a loss of a morphine-induced increase in place preference and physical dependence in mice lacking the μ -receptor gene.

Buprenorphine reward could be mediated through several receptors which include κ , δ and ORL-1 receptors. CCAM (3mg/kg) and norBNI (10 mg/kg) alone or in combination failed to block the reward of buprenorphine (0.3 mg/kg), suggesting that κ -receptors are not implicated in this effect. Interestingly, Ide et al (2004) reported that buprenorphine maintains its reward ability in homozygous μ -receptor knockout mice but pretreatment with the nonselective opioid antagonist naloxone abolished this ability. These authors also showed that there was a partial block by pretreatment with either the δ -receptor antagonist naltrindole or the κ -receptor antagonist norBNI. Indeed, activation of μ -receptor and antagonism of κ -receptors leads to increase of dopamine release in the different brain area, such as VTA and NAc, which may result in reward and the use of non-selective opioid receptors antagonist may prevent the release of dopamine and abolish this reward. Also, Ide et al (2004) suggested that μ - and δ - and/or κ - receptors are each involved in the rewarding effects of buprenorphine. However, in another study Marquez et al (2007) reported that buprenorphine failed to induce CPP in μ -receptor knockout mice. This controversy between these two studies could be explained by using different strain and protocols in their studies. On the other hand, the failure of CCAM and norBNI in our study to block buprenorphine reward could be explained because the dose of both antagonists is low and CPP task is very sensitive to low doses of μ -receptor agonists and dopamine release. Also, to prevent buprenorphine reward we need to block μ -receptors completely. Ideally, in our study, we should have done a dose response curve for CCAM and norBNI in CPP at the beginning of the experiment. However, due to time limitation and resource we were not able to do that. Also, to investigate the effect of the opioid receptors in buprenorphine reward, κ -receptors knockout mice would be an ideal approach.

The data in this chapter revealed that BU10119 (1 mg/kg) non-significantly increased the time spent in the drug-paired compartment. However, this increase was close to being significant and CCAM was able to reduce this increase to the control level. It has been reported that sweet food (Agmo and Marroquin, 1997) and fluoxetine (2.5 mg/kg) (Collu et al., 1997) elicited CPP. Also, Collu et al (1994, 1996) have reported that both fluoxetine and imipramine, when given chronically, produce CPP for a single dose of cocaine ineffective in control rats. However, fluoxetine been reported to decrease cocaine and amphetamine self-administration in rats (Carroll et al., 1990). All these studies may suggest that any unconditioned stimulus in CPP which may have a positive effect or may possess antidepressant or anxiolytic effects may increase the time spent in the drug-paired compartment and this could explain the ability of BU10119 to increase the time spent in the drug-paired compartment. However, BU10119 is κ -receptor antagonist and it may cause an increase in dopamine level in brain reward circuit and that may contribute its effect on CPP. Moreover, BU10119 may have a low partial μ -receptor agonist activity, which was not detected in the tail-flick assay, which could be responsible for that effect and that may explain why CCAM was able to reduce such an effect on CPP. On the other hand, BU10119 and CCAM are μ -receptor antagonists and given both of them in CPP may explain the ability of combination to reduce the time spent in the drug-paired compartment.

In summary, buprenorphine (0.3 and 1 mg/kg) was rewarding in CPP. Also, naltrexone (1 and 3 mg/kg) was able to block this effect and it was established that the combination dose of buprenorphine (1 mg/kg) with naltrexone (1 mg/kg) is neither rewarding nor aversive in the CPP paradigm in adult CD-1 male mice. Also, BU10119 was without significant rewarding or aversive effects In CPP paradigm.

Chapter 5

Effects of combination buprenorphine/naltrexone and single compound BU10119 on depression and anxiety-related behaviours

5.1. Can we model depression and anxiety in lab animals?

Depression is a complex mental disorder and its diagnosis depends on patient symptoms, such as a feeling of sadness, low self-worth, anhedonia, feelings of guilt, and recurrent thoughts of death (American Psychiatric Association, 2013). The heterogeneity of this disorder suggests that there are multiple different biological mechanisms involved in its pathophysiology. Moreover, several possible causes and factors have been reported and claimed to increase the chance of depression, including, alteration of brain chemistry, genetic and environmental factors (Charney and Manji, 2004). Indeed, the wide range of signs and symptoms and the different possible etiologies of depression highlight the difficulty to mimic these features in animals in labs. Indeed, recurring urges to commit suicide or thoughts of death, or thoughts of guilt, are impossible to model in laboratory animals (Fuchs and Flügge, 2006; Fernando and Robbins, 2011). Therefore, it is almost impossible to know whether a laboratory animal is depressed or not. However, depression produces a wide variety of symptoms and features that can be reproduced independently and evaluated in animals, including physiological alterations, for example biochemical, endocrinological or neuroanatomical, and behavioural features such as cognitive impairments and despair (Hasler et al., 2004; van der Staay et al., 2009).

5.2. Validity of the animal models of depression and anxiety

The use of animal models is an important tool in investigating the pathophysiology of depressive disorders and also in screening and developing novel antidepressants (Nestler and Hyman, 2010; Fernando and Robbins, 2011). Animal models assessing depression-related behaviours depend on the exposing the animals to different kinds of stressors which cause behavioural changes similar to the depression, which can be stopped with antidepressant drugs (Weiss and Kilts, 1998; Willner and Mitchell, 2002).

An ideal animal model of human depression and anxiety must satisfy minimal criteria as much as possible. It must be able to model pathological, physiological or behavioural changes by reproducing these conditions that are believed to cause depression (construct validity) and parallel the numerous symptoms of human depression (face validity). Also, the ability to reverse the behavioural changes by treatment which are effective in humans (predictive validity) is an important criterion in an animal model of depression and anxiety (Willner and Mitchell, 2002; van der Staay et al., 2009).

In this chapter, a number of behavioural tasks for assessing antidepressant and anxiolytic drug action have been used and are discussed here in terms of their validity.

5.3. Behavioural paradigms to assess depression- and anxiety-related behaviours

5.3.1. Forced swim test

The forced swim test (FST) was developed by Porsolt and colleagues (Porsolt et al., 1977) originally in the rat and subsequently in the mouse (Porsolt, 2000). In FST rats are placed for 15 min in the water then they are removed and returned to their home cages. Then they are placed in the cylinders 24 h later and the total duration of immobility is measured during a 5 min test. However, in mice there is no need for the pre-swim session (Porsolt, 2000). In preclinical studies, this test is one of the most widely used tools for assessing antidepressant activity and this is because it's easy to be used, reliable between laboratories and its ability to detect the majority of antidepressants and discriminates antidepressants from neuroleptics and anxiolytics (Borsini and Meli, 1988). Even though it works after 30 minutes of drug administration, it is still highly efficient in predicting the antidepressant potential of tested drug (Petit-Demouliere et al., 2005) and it has been reported to have the highest rates of predictive validity for antidepressants (Holmes, 2003). It involves placing a rat or mouse in a glass cylinder with enough water so that it cannot touch the bottom with its hind paws (Porsolt et al., 1977) (Figure 5.1). At the beginning of the test the animal movements

will increase and eventually will adapt to an immobile position. However, the animal will make a necessary movement to maintain its head above the water. It is known that tricyclic antidepressants, atypical antidepressants, and monoamine oxidase inhibitors decrease the rats and mice immobility in a dose-dependent manner in this test (Porsolt et al., 1977; Borsini and Meli, 1988). In this test immobility is considered as a depression-like behaviour (behavioural despair) (Cryan et al., 2005 a,b). A lot of efforts have been made to increase the sensitivity of the traditional FST. Therefore, an enhancement of the sensitivity of FST was made by several simple procedural changes (Lucki, 1997). These improvements include increasing the water depth to 30 cm from old depths of 15–18 cm and using a time of a 5-s interval to rate the animal behaviour. These enhancements enable researchers to distinguish certain behaviours, particularly: (1) climbing behaviour, which is defined as upward-directed movements of the forepaws along the side of the swim chamber; (2) swimming behaviour, the movement (usually horizontal) throughout the swim chamber that also includes crossing into another quadrant. It has been reported that swimming behaviour predominates for serotonergic antidepressants and climbing predominates for drugs that are primarily noradrenergic, allowing the FST to detect this distinction (Lucki, 1997; Cryan and Lucki, 2000). Also, one of the distinguishing characteristics of the FST is that acute and chronic drug treatments are effective in this model. Indeed, acute administration of fluoxetine (4-64 mg/ kg, i.p.) reduced the time spent immobile in the FST with CD mice (Da-Rocha et al., 1997). On the other hand, Detke et al (1997) reported that chronic treatment with low doses (1-5 mg/kg) of antidepressant drugs which were not effective subchronic produced antidepressant-like effects and that these results support the validity of the FST as a behavioural screen for antidepressant drugs.



Figure 5.1. The mouse FST set-up.

5.3.2. Hyponeophagia paradigms

Hyponeophagia tests include novelty induced hypophagia (NIH) and novelty suppressed feeding (NSF) that are used in rats and mice (Dulawa, and Hen, 2005; Bodnoff et al., 1988). These behavioural paradigms use the innate behaviour of rodents to explore a novel environment but introduce an approach-avoidance conflict. In these paradigms, animals are motivated to approach food or drink but the novel environment is aversive. These paradigms do not require sophisticated training, are not confounded by painful stimuli, are relatively simple and not costly (Blanchard et al., 1998; Belzung et al., 2001). Here, a NIH procedure based on the method of Dulawa and Hen (2005) has been used. In this paradigm, mice are not food/water deprived but are habituated to drink sweetened condensed milk and then given the chance to consume it in two test sessions. The first session occurs in the home cage (control) and the second session in a brightly lit novel cage. It has been reported that hyponeophagia tests have a

good predictive validity because it responds well to the anxiolytic effects of benzodiazepines and antidepressants such as fluoxetine (Dulawa and Hen, 2005). Also, it's able to detect the anxiolytic effects of antidepressants after chronic treatment, which agrees with the clinical profile for this effect in humans (Bodnoff et al., 1989; Dulawa and Hen, 2005). Also, it has been reported that increased anxiety caused by an acute SSRI treatment in human can be detected in this paradigms, an effect that is not reliably detected in other paradigms (Dulawa and Hen, 2005). Thus, this test has a good predictive and construct validity for the anxiolytic effects of chronic antidepressant treatment (Dulawa and Hen, 2005).

5.3.3. Elevated plus maze (EPM)

The elevated plus maze (EPM) is one of the most widely used and straightforward methods for assessing anxiolytic drug effects in rodents (Pellow et al., 1985; Belzung and Griebel, 2001; File, 2001; Holmes, 2001). The EPM is a plus-shaped maze, raised off the floor with two closed and two open arms facing each other and separated by a central platform (Figure 5.2). The concept of EPM is based on innate exploration and an approach-avoidance conflict generated by the aversive elevated open arms. In general, the rodent behaviour is characterised by avoidance of open arm with a high preference for the closed arms (Pellow et al., 1985; Holmes, 2001; Kumar et al., 2013). In literature review, there is a discrepancy in the results of EPM studies and this could be explained by variability in test conditions that may affects the outcome of these results, for example, using different strains, sex, procedures approach, routes of drug administration and method of scoring (Rodgers and Shepherd, 1993; Griebel et al., 2000; Holmes, 2001; King, 2001; Wahlsten et al., 2003;). However, the EPM has a good face and predictive validity and the drugs that are anxiolytic in humans (such as benzodiazepines) are capable of increasing the amount of time spent in the open arms (Pellow et al., 1985; Rodgers et al., 1995; Walf and Frye, 2007).



Figure 5.2. The Mouse Plus Maze apparatus used.

5.3.4. The light-dark (LDB) box test

Crawley and Goodwin designed the light-dark box test before the EPM test in the early 1980s. The LDB test has been used as a pharmacological tool for predicting the anxiolytic effects of novel compounds (Crawley and Goodwin, 1980; Crawley, 1981). It's a behavioural paradigm to assess anxiety that is simple, quick to use, without requiring the prior training of animals. Like the EPM, it is an approach-avoidance task, based on the nature of rodents to avoid the brightly illuminated areas and their spontaneous exploratory behaviours in a novel environment. The test apparatus consists of two interconnecting chambers. One arena is smaller, black and non-illuminated and the other is aversive being large, open and brightly lit (Figure 5.3). Thus, the measures of exploration in the illuminated area (time, locomotion, the number of transitions) is used as experimental indices of anxiety-related behaviour (Crawley and Goodwin, 1980; Ramos, 2008; Campos et al., 2013). Benzodiazepine treatment increases the time

spent in the lit compartment and increases the number of crossing between the two compartments (Crawley, 1981; Pellow et al., 1985; Lister, 1987; Hascoët and Bourin, 2009). However, treatment with psychomotor stimulants such as amphetamine or genetic-induced hyperactivity in basal locomotor activity could produce false positive results (Holmes, 2001). In general, LDB box has a reasonable good predictive validity when screening novel compounds (Crawley, 1981; Hascoët et al., 2001).

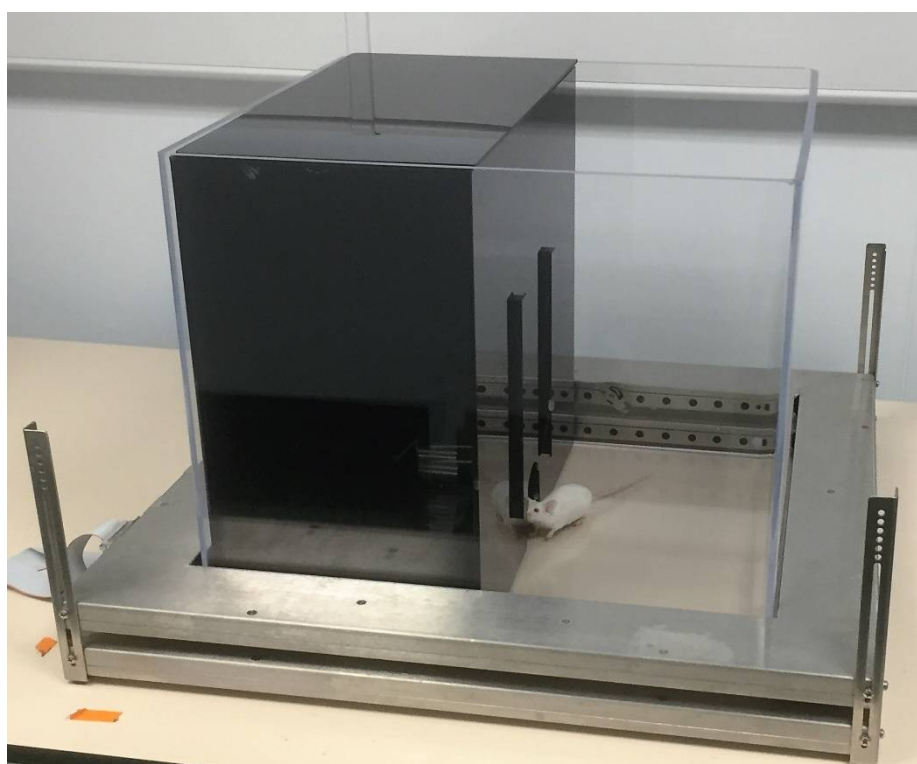

Figure 5.3. The light-dark box apparatus.

5.4. Chapter aims

The behavioural paradigms used were chosen because they have a good predictive validity for screening a novel antidepressant and anxiolytic drugs. In this chapter, FST, NIH, EPM and LDB were used to evaluate whether the combination buprenorphine/naltrexone (1 mg/kg) and BU10119 (1 mg/kg) have antidepressant and anxiolytic effects in adult CD-1 male mice. Importantly, at the doses tested, none of these drugs affected locomotor activity which is a significant confound of behavioural experiment (Chapter 4).

5.5. Methods

5.5.1. Forced swim test

Mice were individually placed in a glass beaker (height 44 cm, diameter 22 cm) filled with water at a depth of 30 cm, at $25 \pm 2^\circ\text{C}$ and behaviour recorded (Sony DCR-SR52) for 6 minutes. Mice were removed, dried and returned to their home cages. Mice were scored, blind for treatment, for three measures: swimming, immobility, climbing and the time spent engaged in these behaviours in the last 4 minutes of the test reported. Drug treatments were saline-injected controls, buprenorphine (1 mg/kg) alone, naltrexone (1 mg/kg) alone, buprenorphine/naltrexone (1 mg/kg) combination, BU10119 (1 mg/kg) and the selective serotonin reuptake inhibitor (SSRI) fluoxetine (20 mg/kg). All drugs were administered 1 hour before testing (naltrexone 10 min before buprenorphine). However, The irreversible μ -antagonist CCAM (3 mg/kg), administered 24h before buprenorphine (Porsolt, 2000; Petit-Demouliere et al., 2005).

5.5.2. Novelty-induced hypophagia

Mice were individually housed for three days before training began. Training consisted of three consecutive days in which mice received concentrated milk (1:3, sweetened condensed milk: water) for 30 minute in their home cage and lighting levels were set to 20 lux. On day four mice underwent home cage testing. On day 5, novel cage testing was conducted by placing the mouse in a clean cage of the same dimensions as their home cage, but with no bedding or shavings and under bright lighting (300 lux, Figure 5.7; 500 lux, Figure 5.8A and 5.8B). The latency to drink was recorded during a 30-minute test period in both the home and novel cage environments. In the first experiment (Figure 5.7), mice received buprenorphine and naltrexone alone, or combined, or the SSRI fluoxetine (20 mg/kg) 1 h prior to testing (naltrexone 10 min before buprenorphine). Mice were also administered the κ -antagonist norBNI (10 mg/kg; 24–48 hours before testing, after training on day 3). In the second and third experiment (Figure 5.8A and 5.8B), the lighting was increased to make the novel cage more aversive and the ability of the κ -receptor antagonists was

investigated. Also, the ability of the irreversible μ -receptor antagonist CCAM (3 mg/kg) (Figure 5.8B) to block the effects of buprenorphine and naltrexone was investigated by the administration after training on day 3 (Dulawa et al., 2004).

5.5.3. Elevated plus maze (EPM)

Mice were placed in the centre of an EPM (EPM2000 Mouse Plus Maze, Campden Instruments) facing an open arm and behaviour was recorded for 5 minutes (Casal-Dominguez et al., 2013). The time spent in, and entries into, the open and closed arms and total ambulation were recorded via infrared photobeams and analysed with Motor Monitor™ software (Campden Instruments). Illumination was 150 lux in the open arms and <1 lux in the closed arms. Mice (n=10/group) were treated with saline, buprenorphine (1mg/kg) alone, naltrexone (1mg/kg) alone, buprenorphine/naltrexone (1 mg/kg) combination, BU10119 (1mg/kg) and diazepam (2 mg/kg) as a positive control, 1h prior to testing (naltrexone 10 min before buprenorphine).

5.5.4. Light dark box (LDB)

Mice were placed at the centre of the lit compartment (400 lux), facing the dark compartment and allowed free access to compartments for 10 minutes (Open field SmartFrame, Campden Instruments) (Casal-Dominguez et al., 2013). The time spent in the lit and dark compartment in the LDB were recorded via beam-breaks using Motor Monitor™ software (Campden Instruments).

5.6. Statistical analysis

FST, EPM and LDB data were analysed using single measures one-way analysis of variance (ANOVA). NIH data were analysed using two-way repeated measures mixed model analysis. Then, Unadjusted Least Significant Difference (ULSD) were used as Post hoc test (InVivoStat 2.3). Only planned pairwise tests were carried out and p values adjusted for multiple comparisons with Benjamin–Hochberg correction. Values are

reported as mean \pm standard error of the mean (SEM) for each treatment group. The number of animals are, n=9 to 12 per treatment group depending on the behavioural paradigm.

5.7. Result

5.7.1 Effects of combination buprenorphine/ naltrexone in the FST

To determine an effective dose of fluoxetine to use as a positive control, fluoxetine (10 and 20 mg/kg) was compared to saline in the forced swim test (Figure 5.4, n=10 per group). One-way ANOVA showed a significant effect of Treatment on the time spent swimming ($F_{(2,25)}=67.82$, $p<0.01$) and time spent immobile ($F_{(2,25)}=4.19$, $p<0.05$) in the last 4 min of 6 min test session. Post hoc comparisons revealed that only the higher dose of fluoxetine (20 mg/kg) significantly increased the time spent swimming ($p<0.01$) and decreased the time spent immobile ($p<0.05$).

Next the effects of buprenorphine (1 mg/kg) and naltrexone (1 mg/kg), alone or in combination, were compared with the SSRI fluoxetine (20 mg/kg) in the forced swim test (Figure 5.5, n=10 per group). One-way ANOVA revealed a significant effect of Treatment on the time spent swimming ($F_{(4,45)} = 6.88$, $p<0.001$) and immobile ($F_{(4,45)} =6.97$, $p<0.001$). Post hoc comparisons to saline treated controls revealed that all drug-treated groups increased the time spent swimming, and decreased the time spent immobile, compared to saline treated mice (all p 's <0.001). Interestingly, immobility times for buprenorphine (1 mg/kg) and naltrexone (1 mg/kg) administered alone were not significantly different from the combination treatment. On the other hand, there was no significant difference on time spent climbing between all groups ($p>0.05$).

Further investigation was carried out to determine whether the antidepressant-like effects of buprenorphine in the forced swim test were related to its partial μ -receptor agonist activity (Figure 5.6, n=10 per group). The irreversible μ -receptor antagonist CCAM (3mg/kg) was administered 24 h before buprenorphine or saline were injected and activity assessed 1 h later in the FST. One-way ANOVA revealed a significant effect of Treatment on the time spent swimming ($F_{(4,40)} =8.84$, $p< 0.001$) and immobile ($F_{(4,40)} = 7.77$, $p< 0.001$). Buprenorphine alone, or in combination with CCAM, produced a significant increase in swimming, and a decrease in immobility,

compared with saline ($p < 0.01$). CCAM alone produced no significant effects on behaviour in the forced swim test as compared to saline control group ($p > 0.05$). These data suggest that the antidepressant-like effects of buprenorphine alone were not mediated by effects at the μ -receptor.

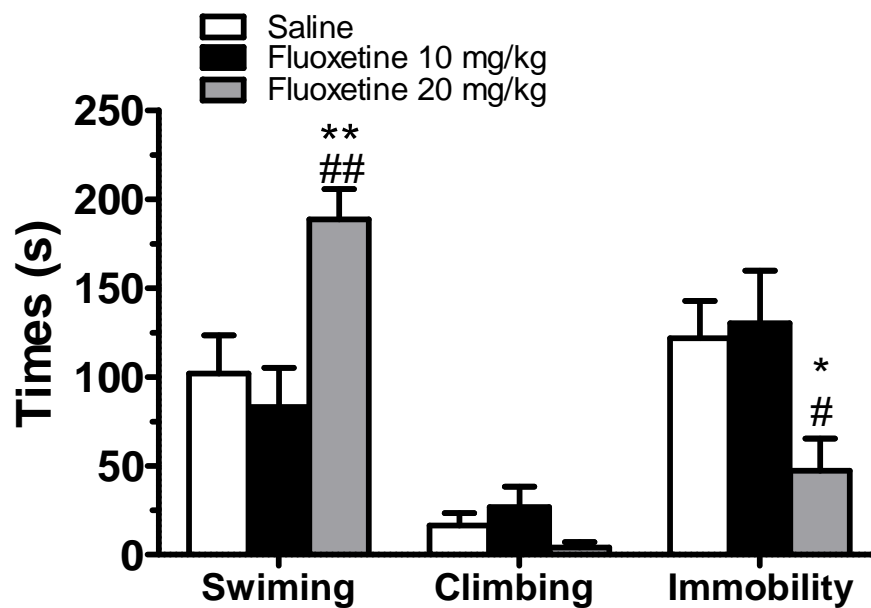

Figure 5.4. Effects of fluoxetine (10 and 20 mg/kg) in adult male CD1 mice in the forced swim test. Data are expressed as mean \pm SEM ($n=10$ per group) counts of swimming, immobility and climbing behaviours during the last 4-min of a 6 min swim test period. * $p < 0.05$, ** $p < 0.01$ as compared to saline. # $p < 0.05$, ## $p < 0.01$ as compared to fluoxetine (10 mg/kg).

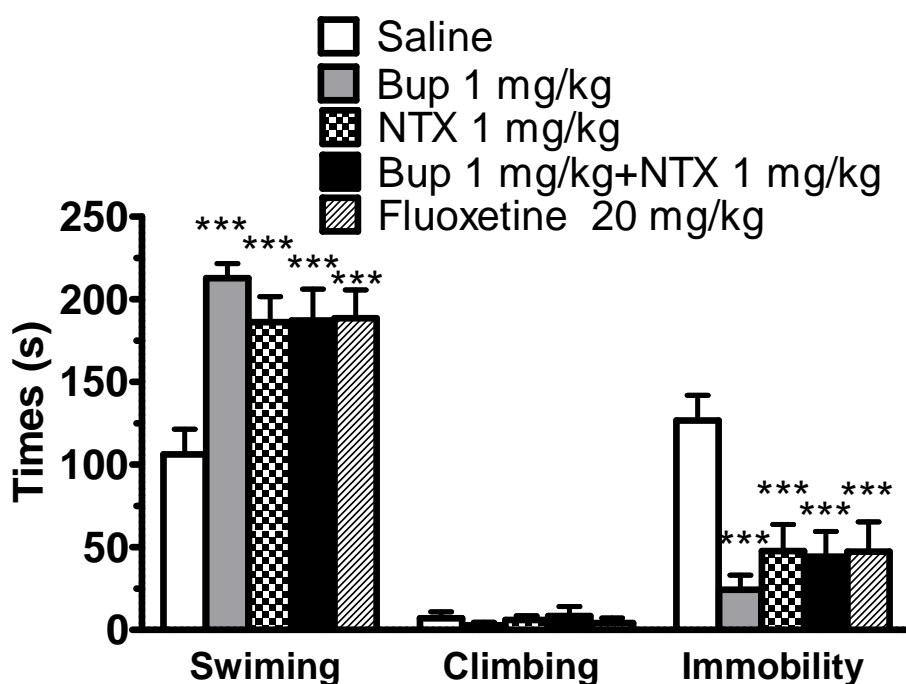

Figure 5.5. Effects of buprenorphine (Bup 1mg/kg) and naltrexone (NTX 1mg/ kg), alone or in combination, in adult male CD1 mice in the forced swim test. The SSRI fluoxetine (20 mg/kg) was administered as a positive control. (A) All compounds under test produced antidepressant-like effects in the forced swim test. Data are expressed as mean \pm SEM (n=10 per group) of time spent swimming, climbing and immobile during the last 4 min of a 6 min swim test. * p< 0.05, ** p< 0.01, ***p< 0.001 compared to saline.

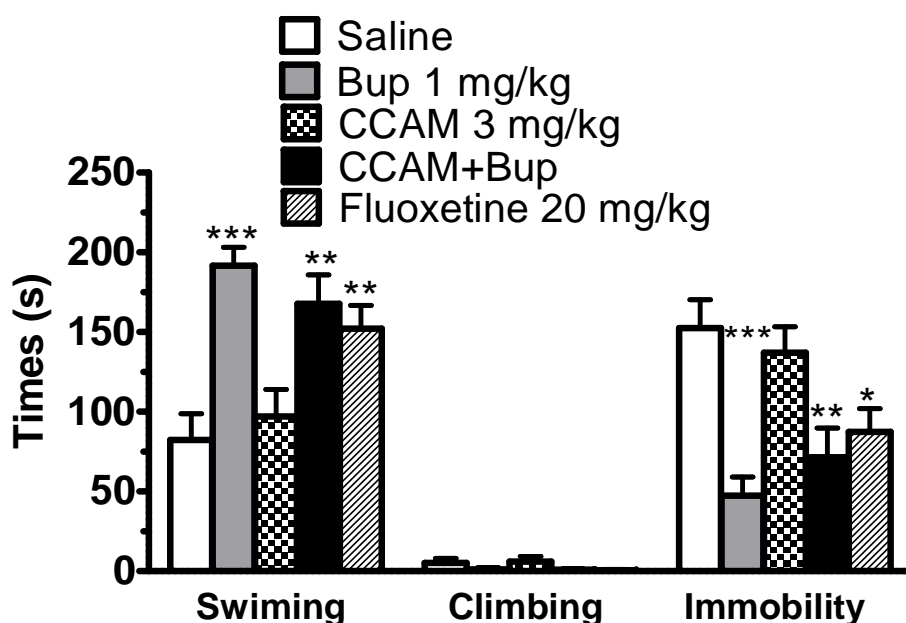

Figure 5.6. Effects of buprenorphine (Bup 1mg/kg) and CCAM (3mg/kg), alone or in combination, in adult male CD1 mice in the forced swim test. The SSRI fluoxetine (20 mg/kg) was administered as a positive control. Data are expressed as mean \pm SEM (n=10 per group) counts of swimming, immobility and climbing behaviours during the last 4- min of a 6 min swim test period. **p< 0.01 and ***p< 0.001 compared to saline. CCAM was administered 24 hr before injecting Bup.

5.7.2. Effects of combination buprenorphine/ naltrexone in the NIH paradigm

Behaviour of mice administered buprenorphine (1 mg/kg) and naltrexone (1 mg/kg), alone or in combination, were compared with the SSRI fluoxetine (20 mg/kg) and the κ -receptor antagonist norBNI (10 mg/kg) in the NIH task (Figure 5.7, n=10 per group). Two-way repeated measures mixed model analysis of the latency to drink times revealed significant main effects of Treatment ($F_{(5,54)}=11.64$, $p<0.001$) and a significant Treatment*Environment interaction ($F_{(5,54)}=10.78$, $p<0.001$). Post hoc comparisons of behaviours in the novel cage showed that, the novel cage was aversive, as demonstrated by the significant increase in the latency to drink in saline treated mice in the novel cage (Mean latency value = 7.52 ± 0.86 minutes) compared with the home cage environment (Mean latency value = 0.53 ± 0.18 minutes, $p<0.001$). Naltrexone alone, or in combination with buprenorphine, significantly reduced the latency to drink milk in the novel cage ($p<0.05$, compared to saline controls). Moreover, the SSRI fluoxetine and the κ -receptor antagonist norBNI, which was administered at the end of training on day 3, also significantly reduced the latency to drink in the novel cage ($p<0.01$, compared to saline). Interestingly, in the home cage, buprenorphine alone significantly increased the latency to drink milk ($p<0.001$) as compared to saline and all drug-treated groups. However, there was no significant difference between buprenorphine and saline treated controls in the novel cage ($p=0.458$).

In the next experiment, we increased the lighting in the novel cage, from 300 lux to 500 lux, to enhance its aversive effects and fluoxetine (20 mg/kg) was used to investigate the new environment (Figure 5.8A-B). Two-way repeated measures mixed model analysis of the latency to drink times revealed significant main effects of Treatment*Environment interaction ($F_{(1,18)}= 5.56$, $p<0.05$). Post hoc comparisons of behaviours in the novel cage showed that fluoxetine (20 mg/kg) significantly reduced the latency to drink milk in the novel cage ($p<0.05$, compared to saline controls) (Figure 5.8A), We also tested the ability of the irreversible μ -receptor antagonist CCAM

(3mg/kg) to block the effects of buprenorphine and naltrexone in the NIH test under this 500 lux condition (Figure 8B, n=9 per group). In CCAM treated mice, CCAM was administered at the end of training on day 3. Two-way

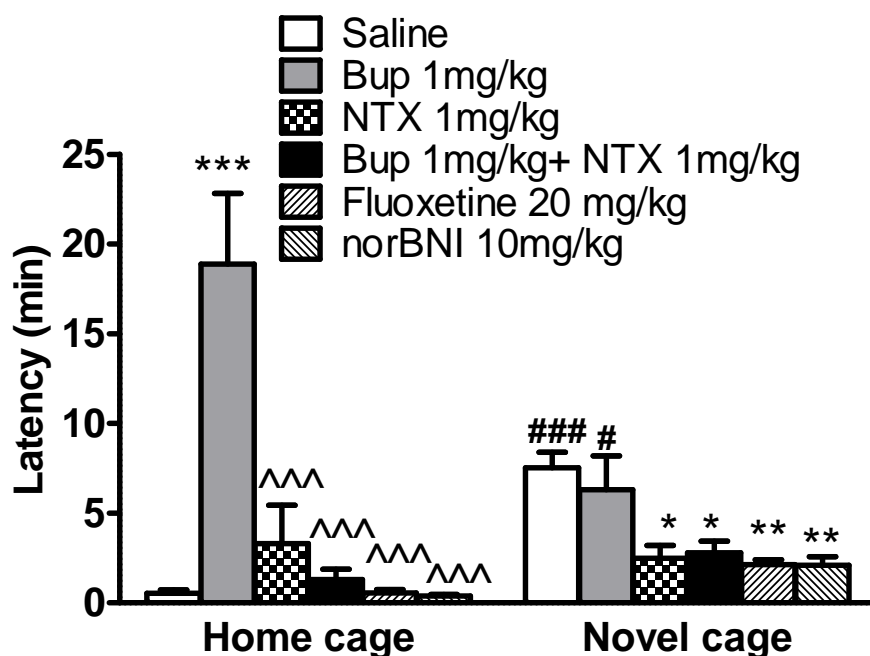

Figure 5.7. Effects of buprenorphine (Bup 1 mg/kg) and naltrexone (NTX 1 mg/kg), alone or in combination, in adult male CD1 mice in the novelty induced hypophagia task (novel cage 300 lux). The latency to drink milk in both the home and novel cage environments is shown. The SSRI fluoxetine (20 mg/kg) was administered as a positive control and the selective κ -antagonist norBNI (10 mg/kg) shown for comparison. All values are the mean \pm SEM. (n=10 per group). * $p < 0.05$, ** $p < 0.01$ and *** $p < 0.001$ compared to saline. ^^ $p < 0.01$ compared to buprenorphine alone. # $p < 0.05$,### $p < 0.001$ for comparison between groups.

repeated measures mixed model analysis revealed significant main effects of Treatment ($F_{(6,56)} = 9.17$ $p < 0.001$) and interaction between Treatment * Environment ($F_{(6,56)} = 26.39$, $p < 0.001$). Post hoc comparisons revealed that, under these conditions, buprenorphine alone significantly reduced the latency to drink in the novel cage ($p < 0.05$ compared to saline control). CCAM blocked the effects of buprenorphine in the home cage to increase the latency to drink ($p < 0.001$) indicating that this effect was mediated by the μ -receptor. In both the home and novel cages, CCAM alone was without significant effect on the latency to drink, compared to saline controls. Furthermore, CCAM did not block the effects of buprenorphine or naltrexone

in the novel cage, indicating that these effects on latency to drink in the novel cage are not μ -receptor mediated.

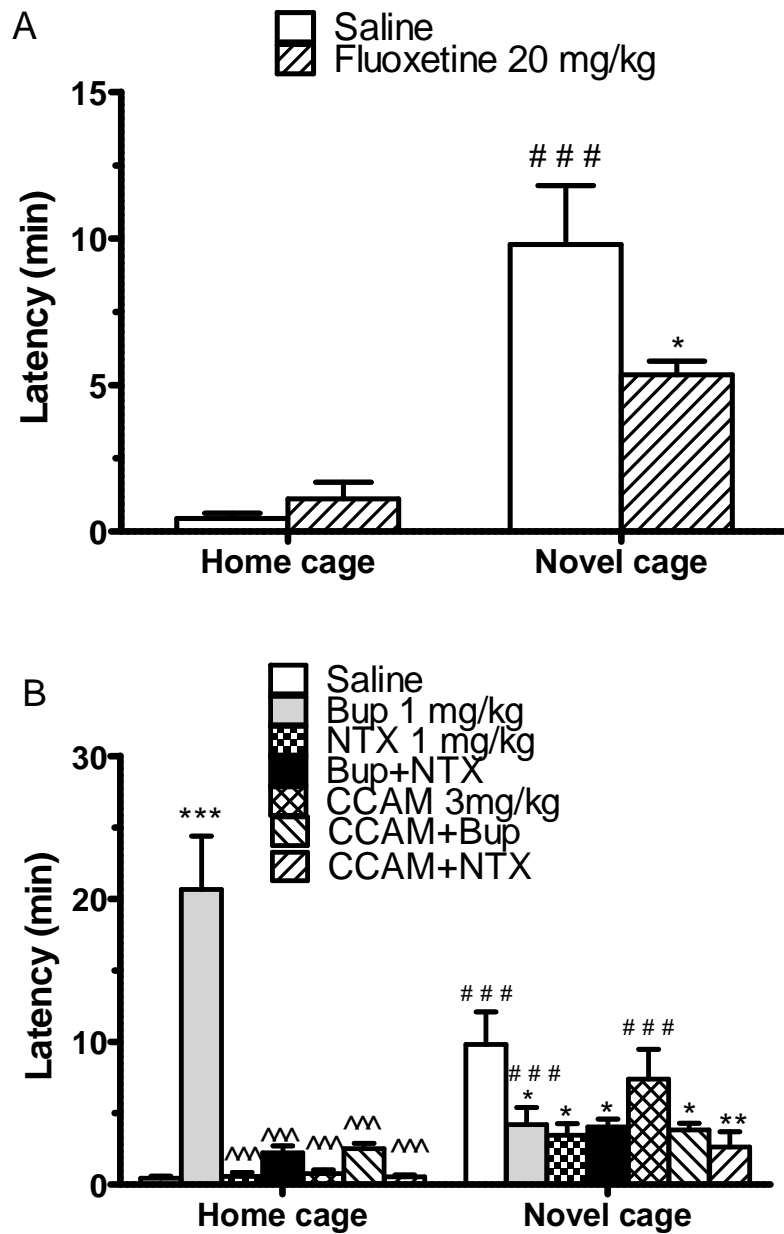

Figure 5.8. Effects of buprenorphine (Bup 1 mg/kg) and naltrexone (NTX 1 mg/kg), alone or in combination, in the mouse novelty induced hypophagia task. The latency to drink milk in both the home and novel cage environments is shown (n=9 per group). (A) The SSRI fluoxetine (20 mg/kg) was administered as a positive control in the new lighting condition (500 lux). (B) The irreversible μ -antagonist CCAM (3 mg/kg) blocks the effects of buprenorphine (1 mg/kg) on latency to drink in the home cage, but not in the novel cage (n=9 per group). All values are the mean \pm SEM. *p< 0.05, **p< 0.01 and ***p< 0.001 compared to saline. ^^p< 0.01 compared to buprenorphine alone. ### p< 0.001 for comparison between groups.

5.7.3. Effects of combination buprenorphine/ naltrexone in the EPM and LDB

To determine an effective dose to use as a positive control, the effects of diazepam (1 and 2 mg/kg) in the EPM test were investigated (Figure 5.9, n=10 per group). One-way ANOVA, revealed significant effects of Treatment on the time spent in ($F_{(2,26)}= 3.76$, $p < 0.037$), number of entries into ($F_{(2,26)} = 3.34$, $p < 0.05$) and distance travelled in ($F_{(2,26)}= 3.24$, $p < 0.05$) the open arms. Within treatment comparisons to saline treated controls revealed that only the benzodiazepine diazepam (2 mg/kg) significantly increased these parameters ($p < 0.05$). However, there was no significant difference in total locomotion between groups ($p > 0.05$).

The effects of buprenorphine (1 mg/kg), naltrexone (1 mg/kg), alone or in combination, and diazepam (2 mg/kg) are shown in Figure 5.10. Analysis of behaviours in the EPM, using one-way ANOVA, revealed significant effects of Treatment on the time spent in ($F_{(4,45)}=3.32$, $p < 0.05$), number of entries into ($F_{(4,45)}=4.42$, $p < 0.05$) and distance travelled in ($F_{(4,45)}= 3.13$, $p < 0.05$) the open arms (Figure 5.10), n=10 per group). Within treatment comparisons to saline treated controls revealed that only the benzodiazepine diazepam (2 mg/kg) significantly increased these parameters ($p < 0.05$). Neither buprenorphine nor naltrexone, alone or in combination, significantly affected behaviours in the EPM. Total ambulation in the EPM was not affected by drug treatment ($F_{(4,45)}=0.95$ $p=0.441$), showing an absence of any sedative effects.

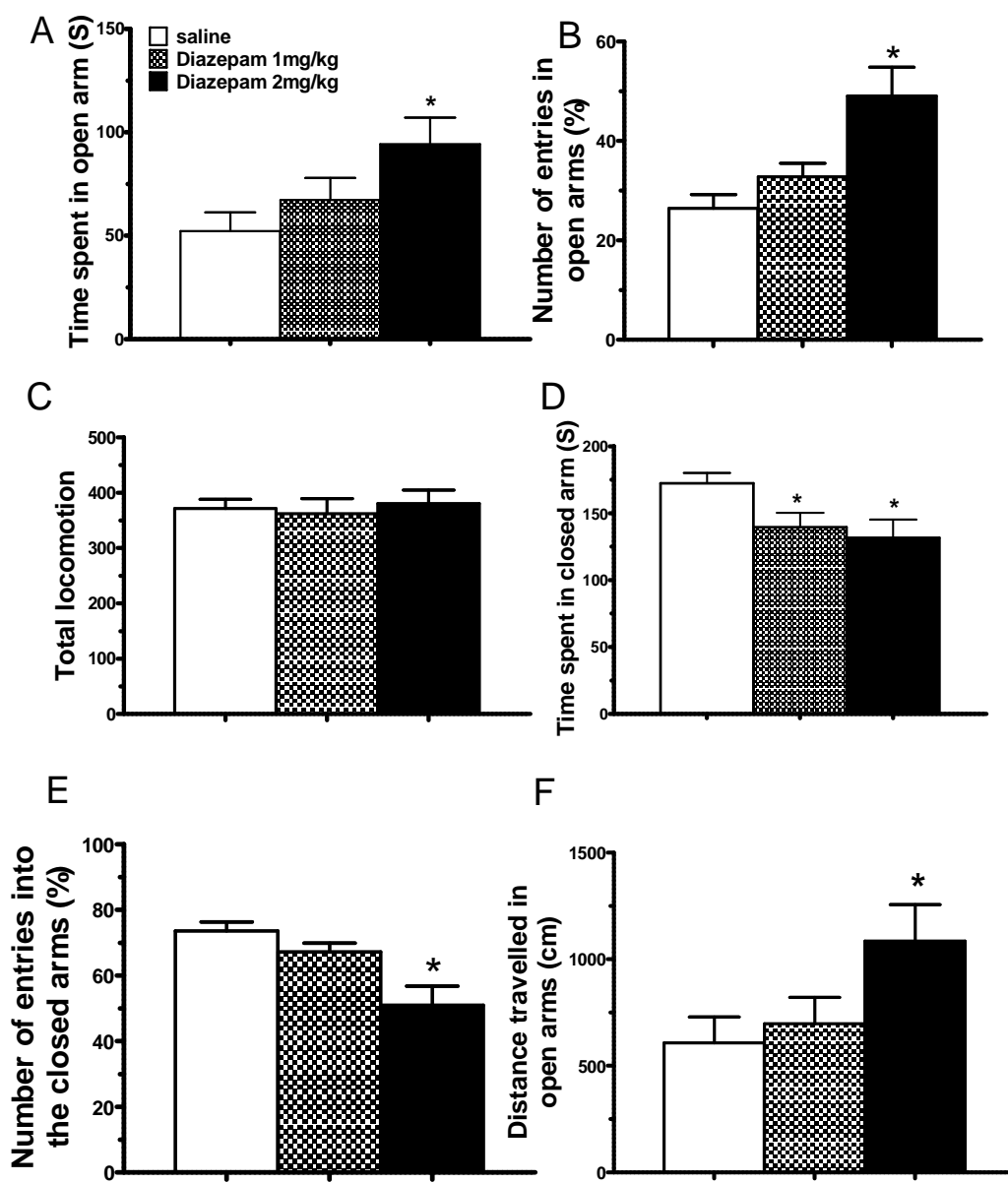

Figure 5.9. Effects of diazepam (1 and 2 mg/kg) in adult male CD1 mice in the elevated plus maze. The time spent in open arm (A), the number of entries into the open arm (B), total locomotion (C) time spent in the closed arm (D) number of entries in the closed arm (E) distance travelled in open arm (F) was recorded. Each column represents the mean \pm SEM (n= 9-10 per group). *p<.05 compared to saline by one-way ANOVA.

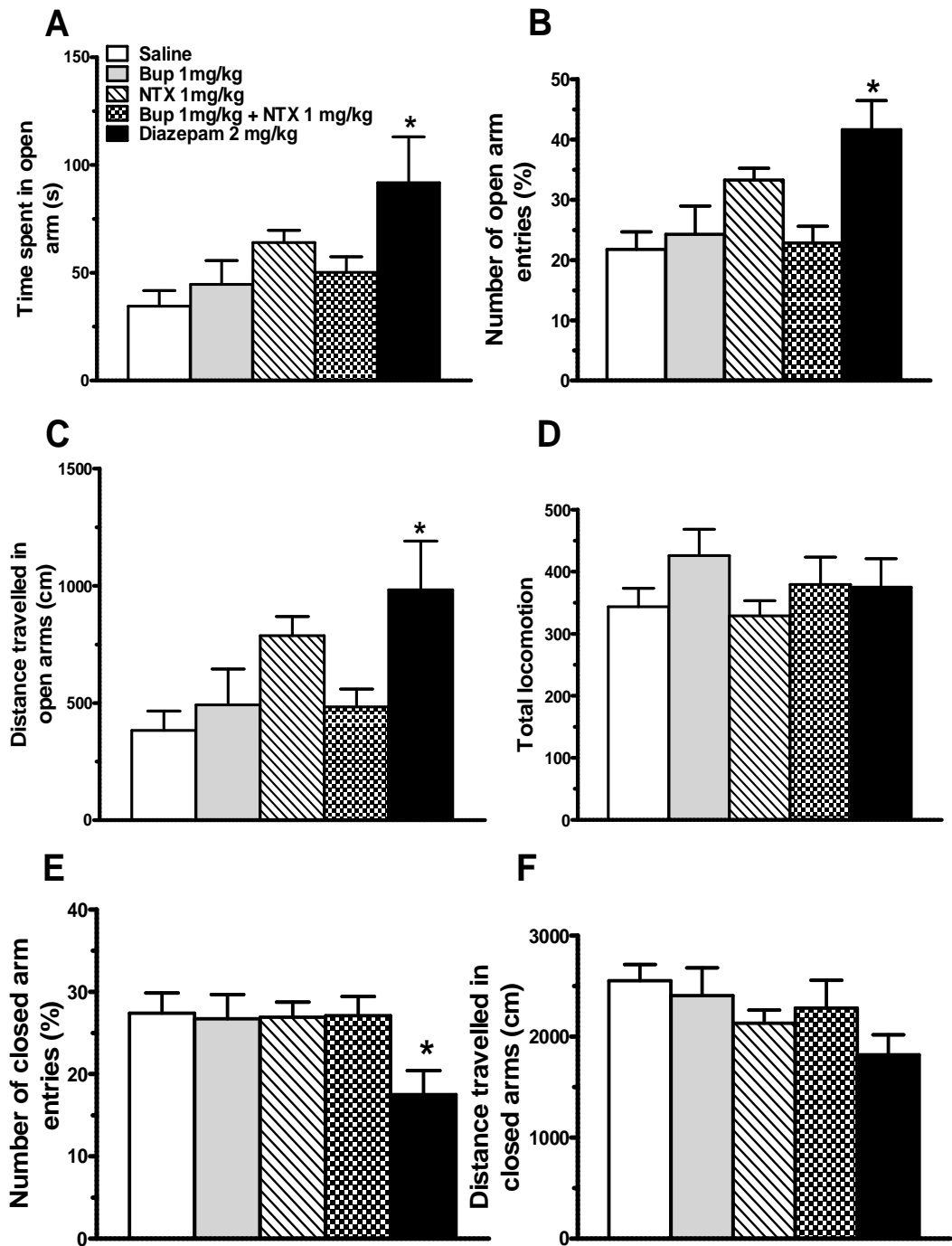

Figure 5.10 Effects of buprenorphine (Bup 1 mg/kg), naltrexone (NTX 1mg/kg), alone or in combination and diazepam 2 mg/kg in the elevated plus maze. (A) The time spent in open arm (B) the number of entries into the open arms (C) distance travelled in the open arm (D) total locomotion (E) the number of entries into the closed arms (F) distance travelled in the open arm (F) was recorded. Each column represents the mean \pm SEM of 10 adult male CD1 mice. * $p < 0.05$ as compared to saline. Analysis was done by one-way ANOVA.

In a separate group of mice, behaviours in the LDB task were examined. There were no significant effects of treatment with buprenorphine and naltrexone, alone or in combination on anxiety-related behaviours in the LDB (Figure 5.11, n=18 per group). One-way ANOVA revealed a significant main effect of Treatment on the time spent in the light ($F_{(4,85)}=3.02$, $p < 0.05$) and dark ($F_{(4,85)}=2.81$, $p < 0.05$) compartment. Within-treatment comparisons to saline controls showed that only diazepam (2 mg/kg) significantly increased the total time spent in the light compartment ($p < 0.05$). As with the EPM, total ambulation in the LDB was not significantly affected by drug treatment ($F_{(4,85)}=2.0$, $p=0.102$), confirming that locomotor effects were not a confound in these experiments.

5.7.4. Effects of BU10119 in the FST

The antidepressant-like potential of the novel compound BU10119 was assessed in the FST. Analysis of behaviours after administration of BU10119 (1mg/kg) and buprenorphine/naltrexone (1 mg/kg) combination in FST, were compared to saline and to the positive control SSRI fluoxetine (20 mg/kg) (figure 5.12A) (n=10). One-way ANOVA revealed a significant effect of Treatment on the time spent swimming ($F_{(3,36)}=6.58$, $p < 0.001$) and immobile ($F_{(3,36)}=7.02$, $p < 0.001$). Post hoc analysis to saline treated controls revealed that all drug-treated groups increased the time spent swimming and decreased the time spent immobile during in the last 4 minutes of the test (all p 's < 0.001). There was no significant difference in time spent climbing between all groups ($p > 0.05$).

5.7.5. Effects of BU10119 in the NIH paradigm

The effects of buprenorphine/naltrexone (1 mg/kg) combination and BU10119 (1 mg/kg), were compared with fluoxetine (20 mg/kg) and the κ -antagonist norBNI (10 mg/kg) in the novelty induced hypophagia task (Figure 5.12B), n=10 per group). Two-way repeated measures mixed model analysis of the latency to drink times revealed significant main effects of Treatment ($F_{(4,75)}=6.13$, $p < 0.001$) and a significant Treatment*Environment interaction ($F_{(4,75)}=5.92$, $p < 0.001$). Within treatment comparisons to saline

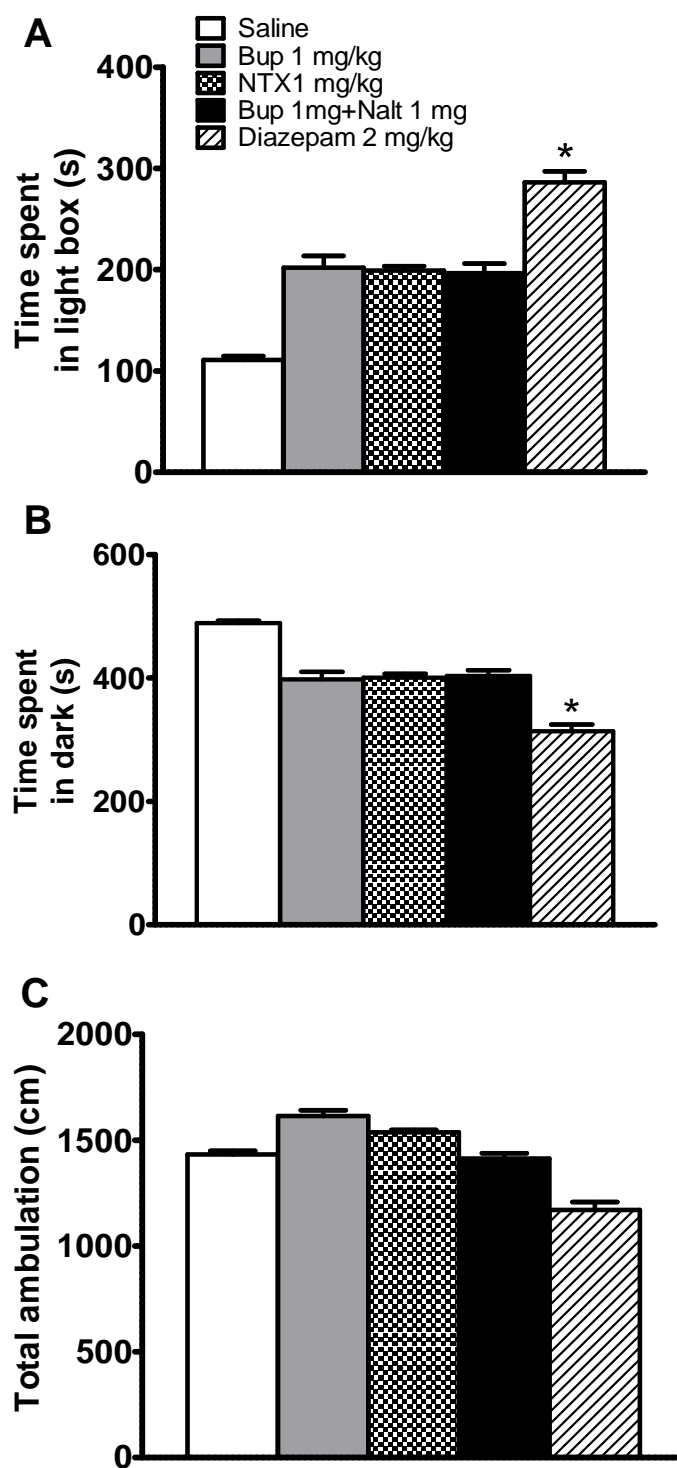

Figure 5.11. Effects of buprenorphine (Bup1 mg/kg) and naltrexone (NTX 1 mg/kg), alone or in combination, in the light-dark box (LDB) (A–C). The benzodiazepine diazepam (2 mg/kg) was included as a positive control. The time spent in the light box (A), in the dark box (B) and total ambulation (C) in the LDB are shown (n=18 per group). All values are the mean \pm SEM. * $p < 0.05$ compared to saline.

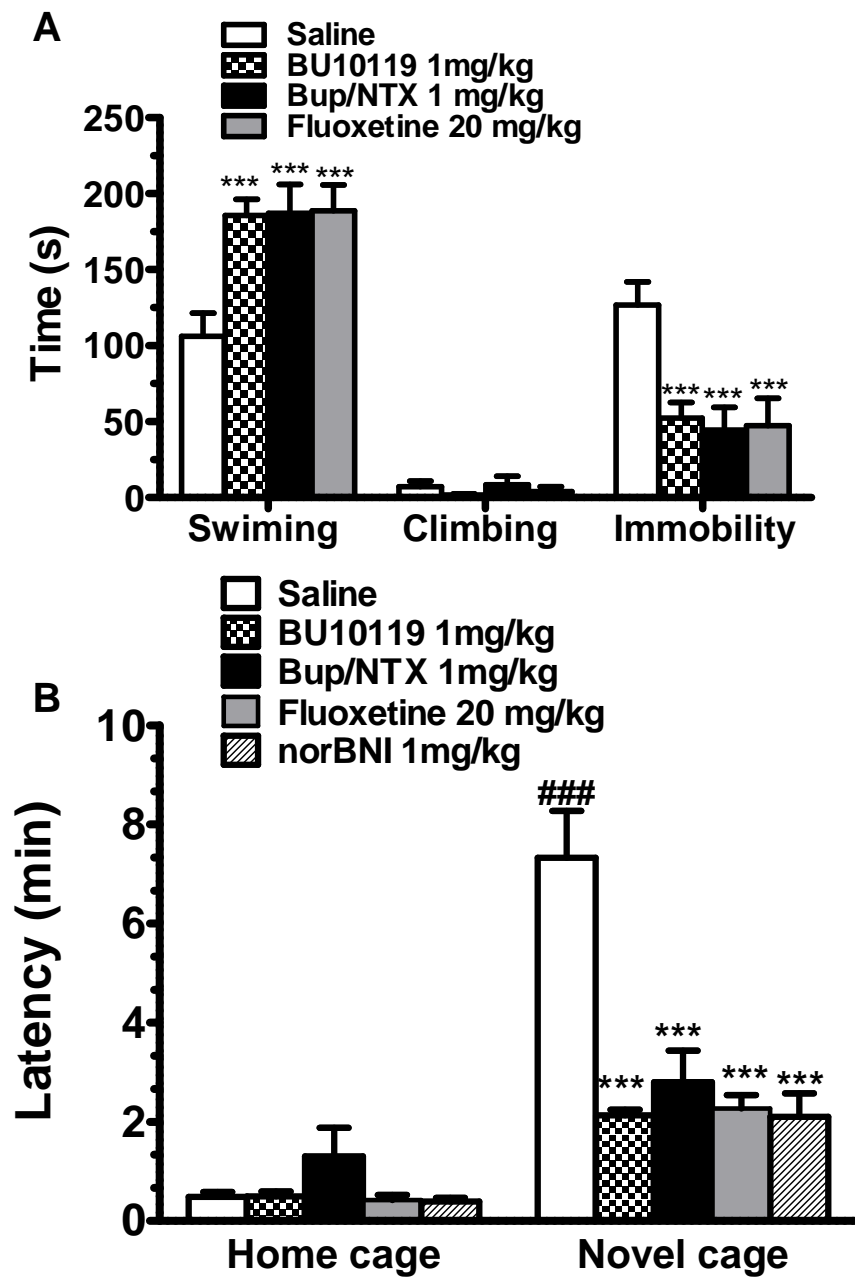

Figure 5.12. (A) Behaviour in the forced swim test for adult CD-1 male mice treated with BU10119 (1mg/kg), buprenorphine/naltrexone (Bup/NTX) (1mg/kg) combination and fluoxetine (20 mg/kg). All values are the mean \pm SEM (n=10 per group).***p <0.001 as compared to saline. The analysis was done by one-way ANOVA. (B) Effects of BU1019 (1mg/kg) and buprenorphine/naltrexone (1 mg/kg) combination in the mouse novelty induced hypophagia task. The SSRI fluoxetine (20 mg/kg) was administered as a positive control and the selective κ -antagonist norBNI (10 mg/kg) shown for comparison. All values are the mean \pm SEM (n=10 per group). ***p< 0.001 compared to saline. ###p< 0.001 for comparison between groups.

treated controls revealed that all drug-treated groups decreased latency to drink milk in a novel cage (all p 's <0.001). Also, the novel cage was aversive by increasing the latency to drink milk in saline control mice (Mean latency value = 7.32 ± 0.94 minutes, 300 lux) as compared to the home cage (Mean latency value = 0.48 ± 0.10 minutes) ($p < 0.001$).

5.7.6. Effects of BU10119 in the EPM and LDB

In the EPM, one-way ANOVA, showed significant effects of Treatment on the time spent in ($F_{(3,36)}=3.29$, $p < 0.05$), number of entries into ($F_{(3,36)}=3.89$, $p < 0.01$) and distance travelled in ($F_{(3,36)}= 3.48$, $p < 0.05$) the open arms (Figure 5.13, $n=10$ per group). Post hoc comparisons to saline treated controls revealed that only the benzodiazepine diazepam (2 mg/kg) significantly increased these parameters ($p < 0.01$). Interestingly, both buprenorphine/naltrexone (1 mg/kg) combination and BU10119 (1 mg/kg) did not show any significant changes in behaviours in the EPM. Total ambulation in the EPM was not affected by drug treatment ($F_{(3,36)}=1.15$ $p=0.342$), showing an absence of any sedative effects.

In the LDB there were no significant changes of treatment with BU10119 (1 mg/kg) and the combination of buprenorphine/naltrexone (1 mg/kg) (Figure 5.14, $n=18$ per group). One-way ANOVA revealed significant main effects of Treatment on the time spent in the light ($F_{(3,60)}=3.59$, $p < 0.01$) and dark ($F_{(3,60)}=3.59$, $p < 0.01$) compartment. Within-treatment analysis to saline controls showed that only diazepam (2 mg/kg) significantly increased the total time spent in the light compartment ($p < 0.01$). As with the EPM, total ambulation in the LDB was not significantly affected by drug treatment ($F_{(3,60)}= 1.26$, $p= 0.29$), which shows that these drugs were not sedative in these experiments.

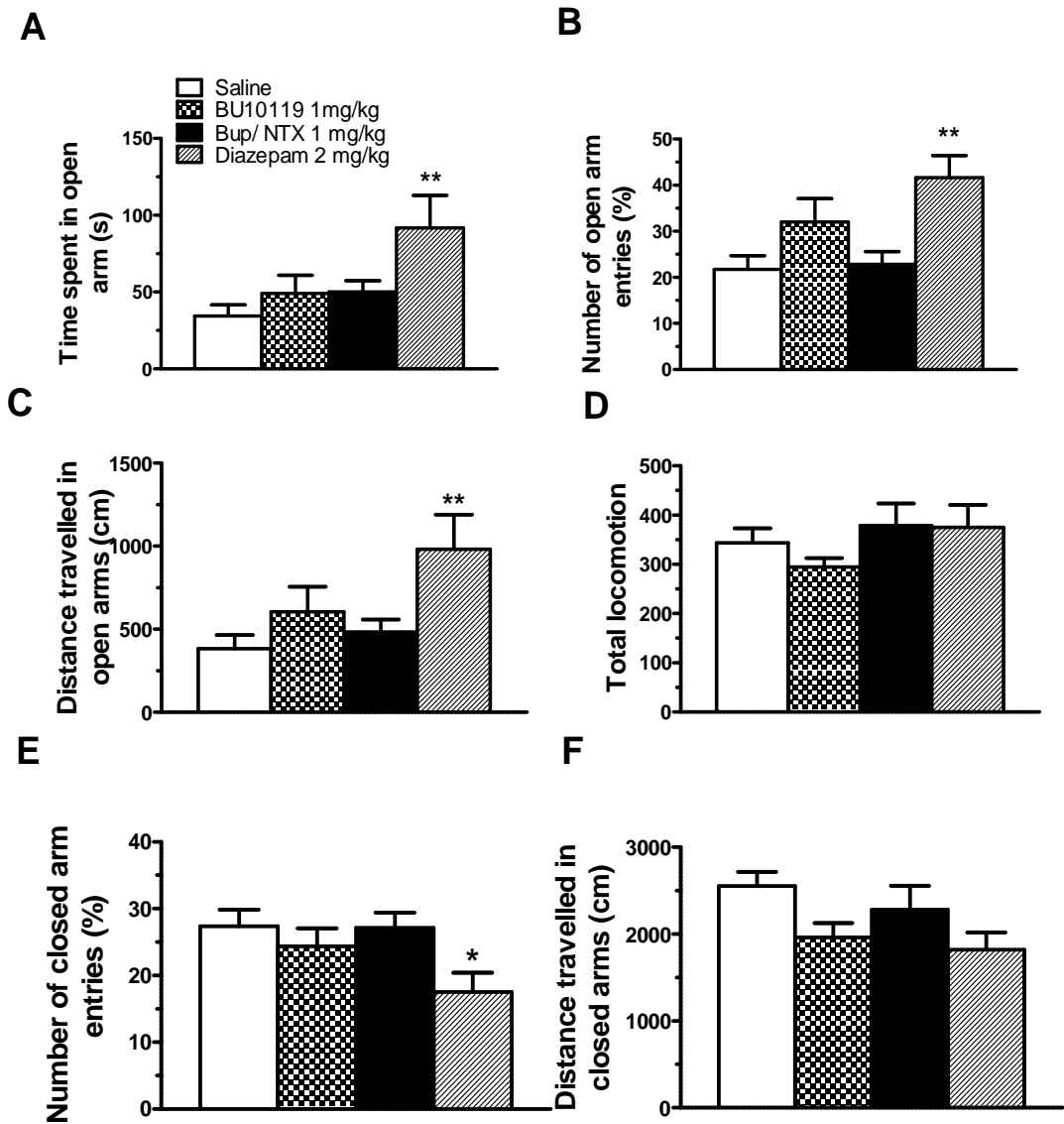

Figure 5.13. Effects of buprenorphine/naltrexone (Bup/NTX) (1 mg/kg) combination, BU10119 1mg/kg and diazepam 2 mg/kg in the elevated plus maze. (A) The time spent in open arm (B) the number of entries into the open arms (C) distance travelled in the open arm (D) total locomotion (E) the number of entries into the closed arms (F) distance travelled in the open arm (F) was recorded. Each column represents the mean \pm SEM of 10 adult CD1 mice. * $p < 0.05$ and ** $p < 0.01$ as compared to saline. The analysis was done by one-way ANOVA.

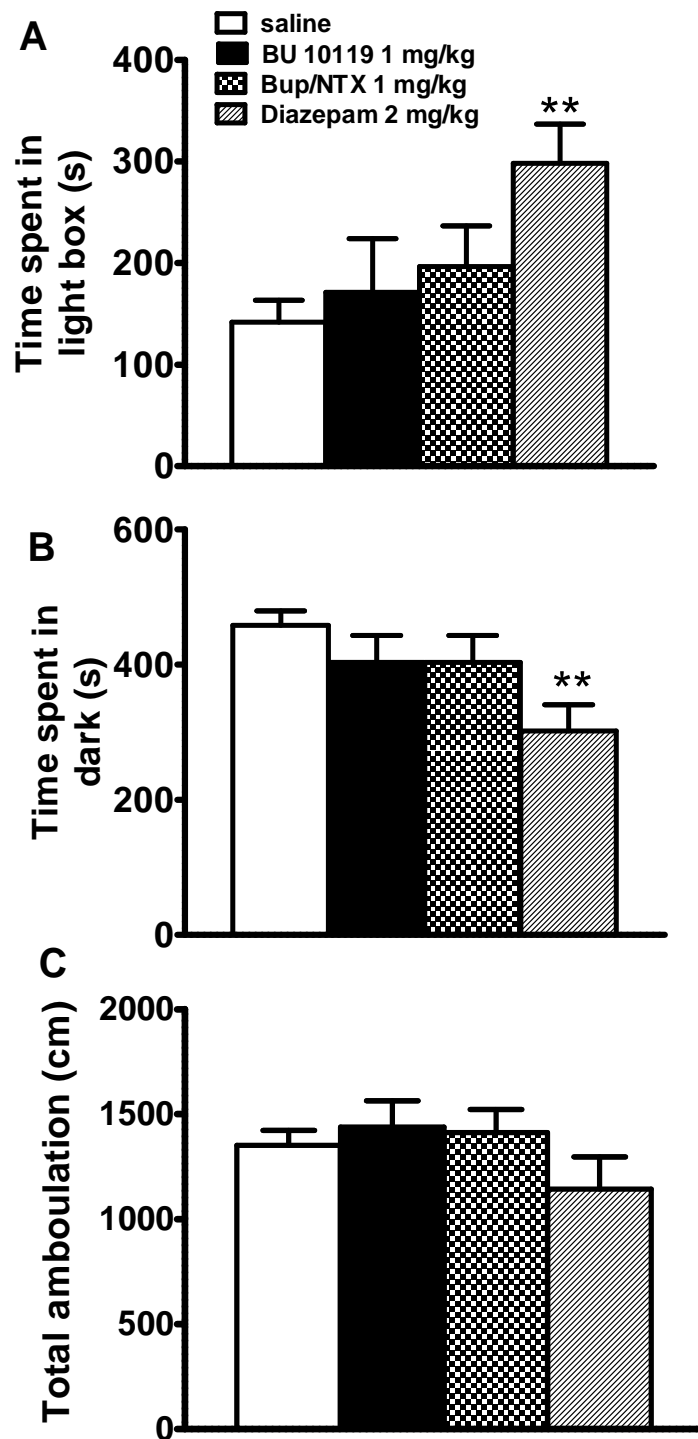

Figure 5.14. Effects of BU10119 (1mg/kg) and buprenorphine/naltrexone (1 mg/kg) combination in the light– dark box. The benzodiazepine diazepam (2 mg/kg) was used as a positive control. The time spent in the light box (A), in the dark box (B) and total ambulation (C) in the LDB are shown (n=18 for buprenorphine/naltrexone, saline and DZP, n=10 for BU10119). All values are the mean \pm SEM. **p < 0.01 compared to saline.

5.8. Discussion

This is the first study to show that the systemic co-administration of buprenorphine (1 mg/kg) with naltrexone (1 mg/kg) in adult male CD-1 mice, produced an antidepressant-like response in behaviours in both the FST and NIH test. The novel compound BU10119 (1 mg/kg), also decreased the time spent immobile in the FST and decreased the latency to drink in the novel cage in NIH task, indicating an antidepressant-like behaviour. These data indicate that these drugs have potential as antidepressant. Interestingly, the combination of buprenorphine with naltrexone and BU10119 were without significant effect on anxiety-related behaviours in the EPM and LDB.

Behavioural paradigms used in this thesis to assess the antidepressant and anxiolytic-like effects of the combination regimen and novel compound BU10119 were validated by using the positive controls fluoxetine and diazepam. Indeed, fluoxetine at the acute and high dose (20 mg/kg) reduced the immobility and increased the swimming time in FST, which was in agreement with the previous studies that reported fluoxetine anti-immobility in FST in adult CD-1 male mice, only at high doses (DeGraaf et al., 1985; Cesana et al., 1993; Da-Rocha et al., 1997; Sánchez and Meier, 1997). Moreover, fluoxetine was effective in reducing latency to drink condensed milk in a novel environment in NIH, which was in agreement with previous studies (Dulawa et al., 2004; Dulawa and Hen, 2005; Surget et al., 2008). However, in these studies fluoxetine was given chronically but in our study it was given acutely. Also, citalopram, the SSRI, was effective only when it was repeatedly given (3 injections of citalopram; 10mg/kg, i.p. over 24 hours) in NIH in mice (Mombereau et al., 2010). The discrepancies between our result, Mombereau et al (2010) and other studies can be explained by the differences in the route of administration, strain, species variability and in the SSRI used which limit the comparison between these studies. Also, Balu et al (2009) reported a notable difference in the sensitivity to chronic administration of fluoxetine between C57Bl/6J and MRL/MpJ mice in the NIH paradigm. In their study, 21 days of treatment with fluoxetine failed to produce a behavioural response in C57Bl/6J mice where

it significantly changed the behaviour in MRL/MpJ mice. Moreover, SSRI, when given acutely, may have some anorectic activity which can be seen in some strains and species which may explain the increase in latency to approach food in this paradigm. The anorectic activity could disappear after adaptation with chronic administration, and that could explain why some SSRI work only after chronic administration. Indeed, acute administration of SSRI, such as sertraline, has been reported to decrease food intake in the rat (Grignaschi et al., 1998; Lucki et al., 1988).

In our study, the classical benzodiazepine, diazepam (2 mg/kg) was used to validate the behavioural paradigms used to assess anxiety related behaviours. Diazepam effects were in agreement with previous studies which reported the increase in the time spent in open arm in the EPM (Pellow et al., 1985; Rodgers et al., 1995; Walf and Frye, 2007) and increase in the time spent in the light compartment in the LDB in mice (Crawley, 1981; Imaizumi et al., 1994, b; Hascoët et al., 2001).

In this chapter, our data are consistent with the previous studies that reported that the κ -antagonists GNTI, norBNI and ANTI have shown antidepressant-like effects (Newton et al., 2002; Mague et al., 2003; Shirayama et al., 2004; Carr et al., 2009) when measured in FST. Moreover, it has been demonstrated that κ -antagonists such as norBNI, GNTI and JDTic decrease anxiety-like behaviours in mouse tests in EPM (Wittmann et al., 2009; Jackson et al., 2010; Van'T and Carlezon, 2013; Hang et al., 2015). Moreover, it has been reported that the κ -antagonists 2-(3,4-dichlorophenyl)-N-methyl-N-[(1S)-1-(3-isothiocyanatophenyl)-2-(1-pyrrolidinyl)ethyl]acetamide hydrochloride (DIPPA) produced anxiolytic-like effects in NIH in the rat (Carr and Lucki, 2010). Also, they reported that the anxiolytic-like effects of DIPPA were obvious after acute treatment which is with an agreement with our result.

In this thesis, buprenorphine, a partial μ -receptor agonist and a κ -antagonist, has shown antidepressant-like effects in FST and NIH.

Previously, buprenorphine has been shown to have antidepressant effects in depressed patients (Emrich et al., 1982) and treatment-resistant depressed patients (Bodkin et al., 1995; Karp et al., 2014). A number of preclinical trials have also demonstrated antidepressant effects of μ -receptor agonist activation. Endogenous enkephalins and endorphins reduced immobility and increased the activity of swimming in rats (Kastin et al., 1978). In the mouse tail suspension test endomorphins (Fichna et al., 2007), morphine, codeine and other agonists reduced the time spent immobile (Berrocoso et al., 2013). More recently, low doses of buprenorphine (0.25 mg/kg and 0.5 mg/kg) have been shown to have antidepressant-like effects in the NIH and FST in C57BL/6 J mice (Falcon et al., 2015). Moreover, Falcon et al (2016) reported that buprenorphine did not reduce immobility in mice with κ -receptor deletion or after pretreatment with norBNI. In contrast, buprenorphine reduced immobility in μ -receptor and δ -receptor knockout mice and in mice pretreated with the ORL-1 antagonist JTC-801. They concluded that the κ -receptor plays an important role in facilitating the effects of buprenorphine in tests sensitive to antidepressant drugs in mice. Our data with the selective irreversible μ -receptor antagonist CCAM supports this idea. In both the FST and NIH task, blockade of μ -receptors did not affect the antidepressant-like response produced by treatment with buprenorphine indicating that these effects are mediated via κ -receptors, rather than μ -receptors.

In this study, it was shown that naltrexone alone produced a significant antidepressant-like effect in the FST and NIH paradigm. This was somewhat surprising since naltrexone is often reported to have aversive effects. Naltrexone is a relatively non-selective opioid receptor antagonist, with a higher affinity for μ - rather than κ -receptors (Giordano et al., 1990). Hence, it was anticipated that naltrexone would reduce buprenorphine's activation of μ -receptors while enhancing its κ -receptor antagonist actions. Also, it was previously shown that mixed μ - κ -receptor antagonists produce both antidepressant and anxiolytic effects in adult CD-1 male mice (Casal-Dominguez et al., 2013). In healthy overweight volunteers, a daily 200 mg dose of naltrexone was found to have no effect on mood symptoms over a

10 week period (Malcolm et al., 1987). However, in opioid-dependent patients, with a high baseline affective burden, depot naltrexone treatment produced a significant improvement in depression scores (Mysels et al., 2011). Perhaps there is therapeutic potential for exploiting the mixed, relatively nonselective opioid receptor antagonists as antidepressant treatments, especially in patients with comorbid substance misuse and mood disorders (Pettinati et al., 2013). Indeed, the antidepressant potential of buprenorphine and naltrexone arises from studies of this combination as a treatment for opioid dependence (Gerra et al., 2006; Rothman et al., 2000). Naltrexone is well established as a treatment for opioid and alcohol dependence, but patient compliance is low. Possible reasons for low adherence include the aversive side effects of naltrexone treatment and the fact that naltrexone has little effect on anhedonia symptoms associated with opioid withdrawal (Bouza et al., 2004; Gerra et al., 2006). The combination of naltrexone (50 mg oral dose) plus buprenorphine (4 mg sublingual) improves mood and reduces the intensity of dysphoria, leading to improved retention of addicts in treatment (Gerra et al., 2006; Rothman et al., 2000). These authors have suggested that this drug combination produces κ -receptor antagonism which improves mood states.

One important caveat with our findings is that they are based on mouse behavioural paradigms. The forced swim test is not a model of depression but is a well-validated and well-established behavioural task for assessing acute antidepressant efficacy (Cryan et al., 2002; Petit - Demouliere et al., 2005). Interestingly, in the FST, antidepressants that target the serotonergic system increase swimming behaviour, whereas those that target noradrenergic systems increase climbing behaviour, thereby decreasing immobility (Detke et al., 1995). In our experiments, buprenorphine/naltrexone combination and BU10119 treatment decreased immobility with a concomitant increase in swimming behaviour, without an effect on climbing behaviour. This may indicate that serotonergic pathways are implicated in the opioid-mediated antidepressant effects seen here, as has been suggested by others (Bruchas et al., 2011). However, it has been

argued that the FST has limited predictive validity and that behavioural paradigm responding to chronic antidepressant treatments have greater validity (Mitchell and Redfern, 2005). The novelty induced hypophagia task is a procedure that has been developed to assess anxiety-related behaviours but has been shown to be sensitive to the chronic anxiolytic effects of antidepressants in rodents (Dulawa and Hen, 2005). In our study, the combination of buprenorphine and naltrexone and the single compound BU10119 have been shown to have antidepressant-like effects in both the FST and the NIH test in adult CD-1 male mice. Further studies are required to assess whether buprenorphine/ naltrexone and BU10119 have any utility in animal models of depressive symptoms such as the Flinders Sensitive Line rat or the chronic unpredictable mild stress model (Overstreet and Wegener, 2013; Monteiro et al., 2015).

Anxiety-related behaviours have been reported to be regulated by the dynorphin κ -receptor system. For example, dynorphin-induced significant anxiogenic-like effects in mice in the LDB and EPM (Narita et al., 2006), while κ -antagonists produced acute and persistent anxiolytic-like effects (Knoll et al., 2007). Interestingly, buprenorphine, over a similar dose range used here (0.3, 1 and 3 mg/kg) has been reported to show anxiogenic effects in NMRI mice in the LDB test (Lelong-Boulouard et al., 2006). However, in our experiments there was no evidence of buprenorphine's reported anxiogenic effects. On the contrary, in the LDB, there was an apparent trend for buprenorphine (and buprenorphine/naltrexone combination) to increase the time spent in the lit compartment although these results did not achieve statistical significance. The absence of a robust anxiolytic-like response for both combination treatment and BU10119 in the EPM and LDB was surprising but this may be because the mice were not sufficiently stressed in these paradigms to activate dynorphin release and alter anxiety behaviours (Shirayama et al., 2004; McLaughlin et al., 2006b; Wittmann et al., 2009). Hyponeophagia, such as tested in the novelty induced hypophagia task, is an anxiety-related measure that is sensitive to the effects of a wide range of pharmacological manipulations including

benzodiazepines and SSRIs (Dulawa and Hen, 2005). Both acute and repeated administration of low dose buprenorphine has recently been shown to reduce the latency to approach food in a novelty induced hypophagia task (Falcon et al., 2015). The NIH test is a conflict-based anxiety test where the aversive novel cage environment suppresses the approach to a highly palatable food. The demonstration of an effect of combination buprenorphine/naltrexone and the single compound BU10119 in the novelty induced hypophagia task, but not in EPM and LDB, supports the potential of κ -receptor antagonists in stress-related tasks (Cryan and Sweeney, 2011). Indeed, Huang et al (2016) investigated the short-acting κ -receptor antagonists effects of zyklophin and LY2444296 in the NIH and EPM tests in mice 1 h postinjection and compared with norBNI (10 mg/kg) 48 h post-administration. In the NIH test, norBNI (10 mg/kg), zyklophin at 3 and 1 mg/kg, or LY2444296 at 30 mg/kg reduced the latency of palatable food consumption in novel cages. In the EPM test, norBNI (10 mg/kg) increased open arm time and % open arm entries or time, but zyklophin at all doses and LY2444296 (30 mg/kg) had no effects. They concluded that all three κ -antagonists had anxiolytic-like effects in the NIH test. However, only the long-acting one norBNI showed anxiolytic-like effects in the EPM test. Their results are quite similar to our study.

In summary, systemic co-administration of buprenorphine (1 mg/kg), naltrexone (1 mg/kg) or in combination and BU10119 (1 mg/kg) in adult CD-1 male mice have antidepressant-like effects in behaviours in both the FST and NIH test and these effects are possibly mediated through κ -receptors, suggesting that these drugs have potential as an antidepressant. However, all drug treatment were without significant effect on anxiety-related behaviours in the EPM and LDB.

Chapter 6

Ability of κ -opioid receptor antagonists to block stress-induced effects

6.1. Introduction

Stress can be defined as a nonspecific reaction to internal and external environmental stressors that might affect the body and is usually accompanied by several cognitive, physiological and psychological changes (Li et al., 2012). Indeed, several studies have reported that stress exposure may increase the risk of developing depression and anxiety in humans (Mazure, 1998; Blazer and Hybels, 2005; Hammen, 2005). To induce stress responses in animals, different models have been established. One of them, restraint stress is widely used and well accepted as a model of stress in rodents, as it is painless and does not cause physical harm to the animals (Buynitsky and Mostofsky, 2009). In addition, acute restraint produces several emotional and autonomic responses that include increase in mean arterial pressure and heart rate (Walker et al., 2003). Moreover, it has been reported that rodents subjected to restraint suffer from behavioral changes such as decreased exploratory activity in an open field (Kennett et al., 1985), decreased exploration of the open arms of an EPM (Guimaraes et al., 1993) and increased immobility in a FST (Sevci et al., 2006). In addition, it was reported that rats exposed to a 21-day-long stress protocol, including immobilization, electric shocks, swimming in cold water, suffer from a reduction in sucrose intake, which is a model of anhedonia and a major sign of depression (Katz, 1981). Moreover, Strekalovae et al (2004) reported that chronic restraint stress in mice caused a significant decrease in sucrose preference, an increase in the immobile time in the FST and that stressed mice spent less time in the open arms of the zero-maze and in the lit compartment of the dark/light box in comparison to control mice. Restraint stress also induces unconditioned and unavoidable neuroendocrine responses, such as increase in plasma corticosterone in rat (Kennett et al., 1985) and mice (Rademacher et al., 2008; Sadler and Bailey, 2013). Moreover, mice when exposed to stress showed an increase in the dynorphin secretion and κ -receptor activation in several brain areas (Bruchas et al., 2007a), and pretreatment with the selective κ -receptor antagonist nor-BNI blocks stress dependent responses (Land et al., 2008; McLaughlin et al., 2003).

Several limbic brain regions have been recognized to be involved in mood disorders that include the PFC, NAc, Amy, and Hip (McEwen, 1999; Newton et al., 2002; Shirayama et al., 2004; Pandya et al., 2012; Falcon et al., 2016). For example, the Hip is sensitive to stress due to the high levels of glucocorticoid receptors expressed in this area (McEwen, 1999). It has been reported that stress leads to neurochemical as well as structural changes in the Hip in animal models (McEwen, 1999; Duman et al., 2001). Moreover, these structural changes might be similar to the atrophy of Hip observed in brain imaging studies of depressed patients (Sheline et al., 1996; Bremner et al., 2000). Many studies have shown that the antidepressant treatment can decrease the atrophy of Hip, as well as the cognitive impairments in depressed patients (Riedel et al., 2002; Sheline et al., 2003; Vermetten et al., 2003). Another example, microinfusions of norBNI into the NAc produced antidepressant-like effect that implicates the importance of this brain region in mood disorders (Newton et al., 2002). Also, it has been reported that the κ -receptor, Pdyn and CRHR1 receptors are expressed in these area and play an important role in mood disorders during stress conditions (DePaoli et al., 1994; Kitchen et al., 1997; Lin et al., 2006; Mansour et al., 1994; Falcon et al., 2016). Indeed, it was reported by Falcon et al (2016) that the exposure to unpredictable chronic mild stress for 3 weeks and chronic buprenorphine treatment caused region-specific changes in the mRNA expression of κ -receptor and Pdyn, emphasizing the potential role of opioid in the treatment of mood disorders. They reported that chronic stress significantly altered opioid gene expression in a number of brain regions (κ -receptor increased in striatum and decreased in Amy and reduced Pdyn in Hip). Interestingly, buprenorphine reversed the effects of chronic stress in some regions (κ -receptor in FC and striatum and Pdyn receptors in FC and Str) which shows the possible interactions between stress, depression- like effects and drug treatment.

6.2. Chapter aims

The aim of this chapter was to investigate whether buprenorphine/naltrexone (1 mg/kg) and BU10119 (1 mg/kg) were able to block stress-induced effects. Different approaches were taken to assessing the effects of stress with and without drug treatment: measurement of plasma corticosterone, development of stress-induced analgesia (SIA), investigating anxiety and depression-related behaviours, and gene expression analysis. The stressor used was a 2h restraint stress administered acutely (1 day) and repeated (3 days).

6.3. Methods

6.3.1. Restraint Stress

Adult CD1 mice in restraint-stressed groups were restrained by a well-ventilated modified 50 ml syringe tube for 2 h for one or three consecutive days from 09:00-11.00 h and they were unable to move forwards or backwards (Poleszak et al., 2006; Sadler and Bailey, 2013). At the end of 2 h restraint mice were returned to their home cage or blood samples taken (section 6.3.2). Stressed mice were daily monitored for signs of stress using a scoring system adapted from Lloyd and Wolfensohn, (1999) (see appendix). All mice were weighed daily immediately prior to being placed in the restraint tube. Non-stressed control mice were weighed daily and returned back to their home cage.

6.3.2. Measurement of corticosterone level

All blood samples of mice were collected at baseline (24 h before restraint) and immediately following the end of restraint stress. Blood samples, 40 µl, were taken from lateral tail vein between 11:00-13:00 h. Heparinised capillary tubes (Hawksley, Sussex, UK) were used to collect blood samples. Blood was collected in centrifuge tubes containing Ethylenediaminetetraacetic acid (EDTA) (2.5 µl) and kept on ice until being centrifuged for 20 min at 4°C at 2000 rcf. Plasma was taken and stored at -20°C until analysis. ELISA, which is enzyme-linked immunosorbent assay, (IBL International, Hamburg, Germany), was used to determine the level of corticosterone according the manufacturers protocol (Sadler and Bailey, 2013).

ELISA Kit contains the following materials:

1. Microtiterwells, 12 x 8 (break apart) strips, 96 wells coated with an anti-Corticosterone antibody (polyclonal).
2. Standard (Standard 0-6), 7 vials, 1 mL, ready to use; Concentrations: 0, 5, 15, 30, 60, 120, 240 nmol/L.
3. Control Low and High, 2 vials, 1 mL each, ready to use.

4. Enzyme Conjugate 250X Concentrate, 1 vial, 150 μ L; Corticosterone conjugated to horseradish Peroxidase.
5. Conjugate Diluent, 1 vial, 25 mL, ready to use.
6. Substrate Solution, 1 vial, 25 mL, ready to use; Tetramethylbenzidine.
7. Stop Solution, 1 vial, 14 mL, ready to use.
8. Wash Solution, 1 vial, 30 mL (40X concentrated).

Before the beginning of the measurement, all reagents and required number of strips were brought to the room temperature before use. The plasma specimens were diluted to 1/10 dilution with Standard 0. Also, dilution of 30 mL of concentrated wash solution with 1170 mL deionized water to a final volume of 1200 ml was made. In addition, dilution of 100 μ L enzyme conjugate with 25 mL conjugate diluent was made, to cover the whole plate. Then, 20 μ L of each standard, control and samples were added into the appropriate wells. Followed by dispensing 200 μ L enzyme conjugate into each well. Then, the strips were thoroughly mixed for 10 seconds. Then they were incubated for 60 minutes at room temperature. Followed by rapidly shake out and removing the contents of the wells. Then the wells were rinsed with diluted wash solution 3times (400 μ L per well). The wells were sharply struck on absorbent paper to remove residual droplets. 100 μ L of substrate solution were added to each well. They were incubated for 15 minutes at room temperature. Then the enzymatic reaction was stopped by adding 50 μ L of stop solution to each well. Finally, the reading were recorded at 450 ± 10 nm with a microtiter plate reader within 10 minutes after adding the stop solution was done.

6.3.3. Assessing stress-induced analgesia by warm water tail-withdrawal test

The warm water tail-withdrawal test was carried out according to the method used previously in chapter 3.2.1. It was used to assess stress-induced analgesia (SIA), after repeated restraint stress for 3 consecutive days (Figure 6.1). norBNI (10 mg/kg) was given once 24 h before the first day of restraint. Baseline latencies were measured before drug injection in

the first and third day of restraint. BU10119 (1 mg/kg) or buprenorphine/naltrexone (1 mg/kg) combination was given daily 1h before restraint, naltrexone (1 mg/kg) was injected 10 minutes prior to buprenorphine. Tail-withdrawal latency was measured 5 minute after restraint ended in the first and third day.

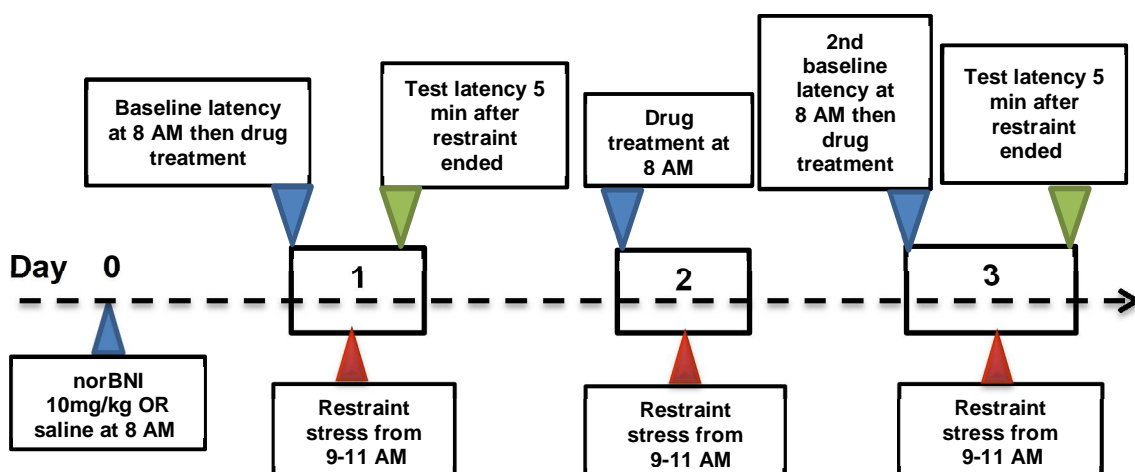

Figure 6.1. Time-line of the warm water tail-withdrawal experimental design, illustrating the time points of daily restraint, drug treatment and latency measurements for assessing stress-induced analgesia.

6.3.4. Behavioural testing

Behavioural testing in the EPM, SPT and FST occurred on day one and day three following 2 hr from the end of restraint (Figure 6.2 A-B). In addition, all blood samples of mice were collected at baseline (24 h before restraint) and immediately following the end of restraint stress. Separate groups of mice were used for each behavioural test. In addition, behavioural testing was done in different room to restraint stress room.

6.3.4.1. Forced swim test (FST) and elevated plus maze (EPM)

FST (section 5.5.1) and EPM (section 5.5.3) were carried out as described previously to assess the effects of 1 day and 3 days of restraint stress.

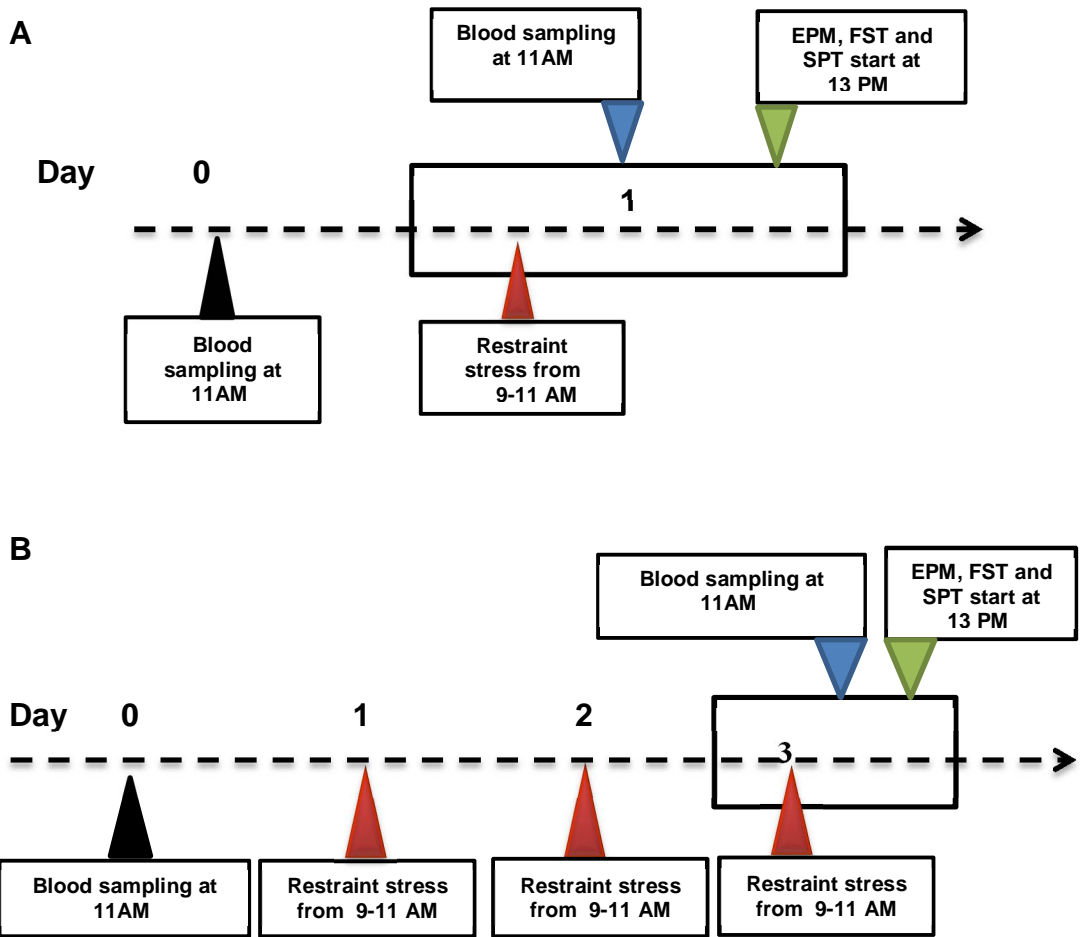

Figure 6.2. (A) one day and (B) 3 days time-line of the restraint stress protocol used. The time points of daily restraint, blood sampling and behavioural testing when assessing anxiety and depression related behaviour.

6.3.4.2. Sucrose preference test (SPT)

Before the last day of restraint, mice were habituated to drinking from 2 bottles of water, for 12h (7pm-7am). The following day, mice were given the choice to drink either water or 1, 2.5 or 5% w/v sucrose during a 12h test (7pm-7am). Bottles were weighed before and after the test, and the preference for sucrose was determined as a percentage of the total volume consumed. (Lewis et al., 2005).

6.3.5. Gene expression

The effects of 3 days of repeated restraint stress in the absence and presence of BU10119 (1 mg/kg) or buprenorphine/naltrexone (1 mg/kg) combination, (given daily 1h before restraint, on gene expression of κ -receptor, prodynorphin and CRHR1 in PFC, NAc, Hip and Amy were assessed. Moreover, norBNI (10 mg/kg) was given once 24 h before restraint. Also, naltrexone (1 mg/kg) was injected 10 minutes prior to buprenorphine.

6.3.5.1. Brain dissection

Mice were killed by cervical dislocation with subsequent decapitation after 2 hr of restraint stress ended, starting from 13 PM. The whole brain was removed immediately and kept on dry ice. Dissection of the prefrontal cortex was done by making a coronal cut of the anterior part of the brain and the olfactory bulb was removed with a razor blade. The mouse brain atlas was used as a reference for brain regions (Paxinos and Franklin, 2001). This was followed by cutting coronal slices and by using multiplex biopsy punch with a tissue punch tool (diameter 2.0 mm) (Miltex GmbH-Japan) then NAc, Hip and Amy were collected from each hemisphere. All microdissection procedures were done on dry ice. All samples were stored at -80°C.

6.3.5.2 RNA isolation

TRIzol (Ambion) reagent was used according to the manufacturer's protocol for the isolation of high quality RNA from mouse brain tissue. Samples were homogenized by adding 0.5ml of TRIzol reagent and mixed

with a pellet pestle (Sigma). A further 0.5ml of TRIzol was added and the homogenate was passed through a 23G needle (BD Microlance, Fisher) (A total of 1ml TRIzol per 50-100mg tissue were used). Then 20µl of glycogen (1mg/ml) were added to the samples and briefly mixed. Homogenized samples were then left to stand for 5 min at room temperature, before 200µl of chloroform was then added in a fume hood. Tubes were shaken vigorously for 15 s and then left to incubate at room temperature for 2-3 min. The samples were subsequently centrifuged at 12,000rpm for 15 min at 4°C. In a fume hood, the upper aqueous phases (≈50% of total volume) were taken into a new tube. Then, the RNA was precipitated by adding 0.5ml of 100% propanol per 1ml TRIzol used and incubated at room temperature for 30 min. After centrifugation (at 12,000rpm for 15 min at 4°C) for 15 min, the supernatant was removed and 1ml of 75% ethanol (Fisher) was added to wash the RNA pellet. Eppendorfs were centrifuged at 7500 rpm for 5 min at 4°C and the liquid was removed, leaving the RNA pellet to air dry (5- 10 min). The air-dried RNA pellet was resuspended in 30µl of RNase-free water and samples incubated at 55-60°C for 15 mins. To remove DNA contamination of RNA, a DNase digest was carried out: 4µl 10X Reaction Buffer, 1µl RNAsin (40U/µl, Fermentas), 4µl DNase (1U/µl, Fermentas) and 1 µl RNase free water. Then sample were centrifuged for 15 mins at 12000g at 4°C. Then the supernatant was removed and the pellet was washed with 250µl of 75% ethanol and vortexed. Samples were centrifuged for 5 mins at 12000g at 4°C then supernatant was removed and the pellet was left to air dry for 15 mins at 37°C (completely dry). Then pellet was resuspended in 20µl RNase free water and stored at -80°C.

6.3.5.3. One step reverse transcription PCR (RT-PCR)

To confirm the presence of our genes of interest (GOI) in non-stressed adult CD-1 male mice in PFC, Hip, NAc and Amy one-step RT-PCR (Invitrogen) was done with the gene specific primers (Sigma) shown in Table 6.1. One-step RT-PCR reactions were performed using Superscript™ One-Step RT-PCR with ®PlatinumTaq (Invitrogen) according to the manufacturer's protocol. Master mixes were created on ice and the

quantities for each PCR reaction were as follows: 12.5µl 2X Reaction Mix containing 0.4mM of each dNTP, 24mM MgSO₄, 10.1µl RNA-free water, 0.4µl of RT/Platinum Taq Mix, which equal 23 ml into 0.2ml PCR tubes then and 1µl template RNA (0.1µg/µl), forward and reverse primers (0.5µl at 10µM) were added. Master mix with primers were mixed with a pipette, before being placed in the PCR machine (DNA Engine Peltier Thermal Cycler, PTC-200, MJ Research). Positive controls were made by amplifying the housekeeper gene ribosomal RNA (18s rRNA). Also, no template negative controls were included.

Gene of interest	Primer	Amplicon length (base-pairs)	Reference
k-receptor	F: GTGGGCTTAGTGGGCAATTCT R:GTGGTAGTAACCAAAGCATCTG	120	Primer Bank
Prodynorphin	F: CTCCTCGTGATGCCCTCTAAT R: AGGGAGCAAATCAGGGGGT	110	Primer Bank
CRHR 1	F:GCAGCCCGTGTGAATTATTCT R:ATGACGGCAATGTGGTAGTGC	83	Primer Bank
18S rRNA gene	F:GTAACCCGTTGAACCCCAT R:CCATCCAATCGGTAGTAGCG	152	Schmittgen et al., 2000

Table 6.1: Gene-specific forward and reverse primers for GOI. Forward and reverse primer sequences were derived Basic Local Alignment Search Tool (BLAST) analysis to confirm the presence of the correct amplicon and expected amplicon size (in base pairs). Primers were used for both one-step RT-PCR and real-time RT-PCR.

Conditions for one-step reverse transcription PCR amplification are shown in table 6.2.

A: cDNA synthesis and pre-denaturation	B: PCR amplification	C: Final extension
Perform 1 cycle of: 50°C for 30 minutes 94°C for 2 minutes	Perform 40 cycles of: Denature, 94°C for 15 seconds Anneal, 60°C for 30 seconds Extend, 72°C for 1 minute/kb	1 cycle of 72°C for 5 minutes

Table 6.2. Conditions for one-step reverse transcription PCR amplification.

Then PCR products were electrophoresed on a 1.2% agarose gel (110 min at 85 mV). GeneSnap (SynGene, 3.00.15) software was used to capture gel pictures.

6.3.5.4. Quantitative real-time RT-PCR

Quantitative real-time RT-PCR was done using SYBR green detection in a two-step process to quantitatively measure the expression of our GOI in mouse brain regions. First step was done by, reverse transcribing the template RNA into cDNA using the Applied Biosystems™ High-Capacity cDNA Reverse Transcription Kit. This was accomplished by adding 2.0µl of 10X RT buffer, 0.8µl of 25X dNTP Mix (100 mM) and 2µl 10X RT Random Primers random, 1µl MultiScribe™ Reverse Transcriptase, 0.25 µl RNase Inhibitor (Ribolock 40U/ µl), 11.45µl of RNA-free water and 2.5µl of RNA (0.1µg/ µl) in PCR tubes. The resulting mixture was pipetted up and down several times to mix. Then the tubes were incubated and following thermal condition were used:

A: cDNA synthesis and pre-denaturation	B: PCR amplification	C: Final extension
Perform 1 cycle of: 50°C for 30 minutes 94°C for 2 minutes	Perform 40 cycles of: Denature, 94°C for 15 seconds Anneal, 60°C for 30 seconds Extend, 72°C for 1 minute/kb	1 cycle of 72°C for 5 minutes

Then the samples were diluted in 450µl (20 µl cDNA+430 Nuclease-free water) and stored at -20°C or second step was started.

Diluted cDNAs (9.2µl = 5 ng cDNA/ reaction) were added to a reaction mix containing GOI-specific forward and reverse primers (0.4µl at 10µM) and 10µl of SYBR green PCR mastermix (Applied Biosystems). The housekeeper genes 18 s rRNA was also amplified. To control against non-specific amplification, a no template control was created by the absence of cDNA template in the reaction mixture. All mixtures were vortexed and centrifuged at 4000rpm for 20 s at 4°C, before insertion into the real-time RT-PCR machine (Applied Biosystems- StepOne Software v2.1).

The real-time RT-PCR amplification conditions for κ -receptor, prodynorphin, CRHR1 and 18s rRNA gene were: 95°C for 10 minutes, followed by 40 cycles of 95°C for 15 seconds and 60°C for 1 minute. This was followed by melt curve analysis to check the specificity of the primers and amplified PCR product.

6.4. Analysing quantitative real-time RT-PCR Data

The exponential amplification of PCR products, known as the crossing point or threshold cycle (CT) number, was automatically calculated using Applied Biosystems-StepOne Software v2.1. Gene changes were quantified using the comparative threshold cycle method ($2^{-\Delta\Delta C_t}$). Firstly, ΔC_t is calculated by normalizing the threshold cycle number of the GOI to the housekeeping gene 18s rRNA. The ΔC_t value is calculated by for example, subtraction of the average expression levels of a target CT value from the sample of the average housekeeping gene (18s rRNA) CT value. Then, the difference between the averaged ΔC_t of stressed treated or stressed non-treated tissue from the averaged ΔC_t of control tissue gives $\Delta\Delta C_t$ and is subsequently transformed to the equation $2^{-\Delta\Delta C_t}$ (Schmittgen et al., 2000).

6.5. Statistical analysis

All data were analyzed using two-way repeated measures mixed model analysis or single measures one-way ANOVA followed by Unadjusted Least Significant Difference (ULSD) post hoc test. In some cases unpaired student t-test were used (Invivostat 2.3). Only planned pairwise tests were carried out and p values adjusted for multiple comparisons with Benjamin-Hochberg correction. Values are reported as mean \pm standard error of the mean (SEM) for each treatment group.

6.6. Result

6.6.1. Acute and repeated restraint stress increase plasma corticosterone level

Exposure to 1 and 3 days restraint stress increased plasma corticosterone level (Figure 6.3). At 1 and 3 days, two-way repeated measures mixed model analysis revealed that there were no significant differences between control and stressed groups in baseline plasma corticosterone measures ($p > 0.05$, $n = 8$). However, post hoc comparison showed that 1 day restraint exposure significantly increased ($\approx 1000\%$) plasma level of corticosterone as compared to baseline levels ($F_{(1,8)} = 38.59$, $p < 0.001$). Similarly, 3 days restraint produced a 900 % significant increase in corticosterone, as compared to baseline levels ($F_{(1,12)} = 54.8$, $p < 0.001$).

The ability of κ -receptor antagonists to block restraint stress induced increase in plasma corticosterone were investigated (Figure 6.4). Two-way repeated measures mixed model analysis revealed that there was no significant difference (between control and stressed groups) in baseline plasma corticosterone levels ($p > 0.05$). However, following 3 days of restraint stress, there was a significant effect of stress on plasma corticosterone level of all treated groups compared to control non-stressed ($F_{(4,21)} = 13.14$, $p < 0.001$). Neither buprenorphine/naltrexone nor BU10119 were able to block stress-induced increase in corticosterone ($p > 0.05$). while norBNI (10 mg/kg) appeared to attenuate stress-induced corticosterone level, this effect was not significant.

6.6.2. Effects of acute and repeated restraint stress on analgesia

In preliminary studies, stress-induced analgesia was evaluated after 1 and 3 days of restraint stress by using tail withdrawal assay (Figure 6.5). Two-way repeated measures mixed model analysis revealed that there was a significant interaction of Treatment*Time ($F_{(1,3)} = 12.86$, $p < 0.001$, $n = 8$). The restraint stress paradigm used produced a significant increase the latency to tail withdrawal (stress-induced analgesia).

The ability of κ -receptor antagonists to block stress-induced analgesia was subsequently investigated (Figure 6.6). Two-way repeated measures mixed model analysis revealed that there was a significant interaction of Treatment*Time ($F_{(12,75)}= 23.3$, $p<0.001$). Stress-induced analgesia was evident after both 1 and 3 days restraint stress with a significant increase in the latency to withdraw the tail as compared to non-stressed mice ($p<0.001$). Interestingly, BU10119 (1 mg/kg), buprenorphine/naltrexone (1 mg/kg) combination and norBNI (10 mg/kg) were able to block stress-induced analgesia ($p<0.001$) caused by both 1 and 3 days restraint stress.

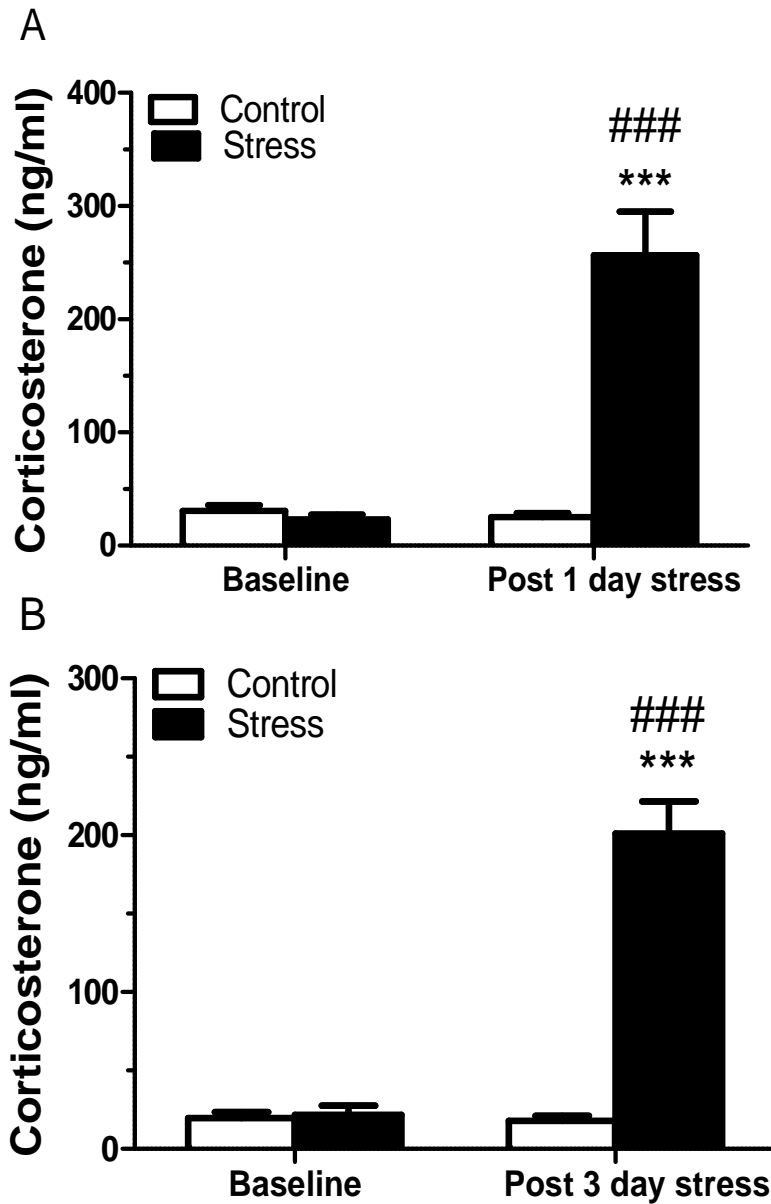

Figure 6.3. Effect of 1 day (A) and three day (B) repeated restraint stress (09:00-11:00) on plasma corticosterone of CD1 male mice. All blood samples were taken from 11:00-13:00 h. Results are expressed as mean \pm SEM, n=8. ***p<0.001 as compared to control. ###p<0.001 as compared to baseline stress group. Analysis done repeated measures mixed model analysis.

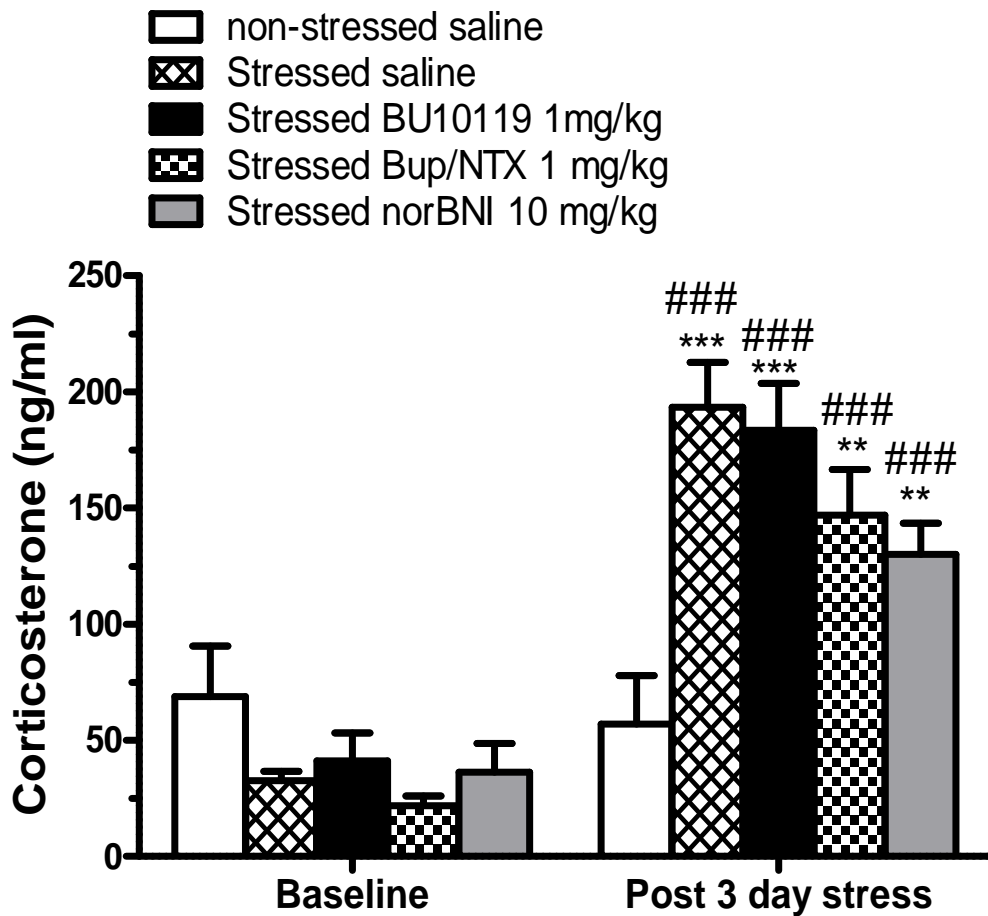

Figure 6.4. Effect of three-day restraint stress (09:00-11:00) and buprenorphine/naltrexone 1 mg/kg (Bup/NTX), BU10119 (1 mg/kg) and norBNI (10 mg/kg) on plasma corticosterone of adult male CD1 mice. norBNI was given once and 24 h before the first restraint stress session. All blood samples were taken from 11:00-13:00 h. Results are expressed as mean \pm SEM, n=8. **p<0.01, ***p<0.001 as compared to non-stressed saline. ##<0.001 comparison between groups. Analysis done repeated measures mixed model analysis.

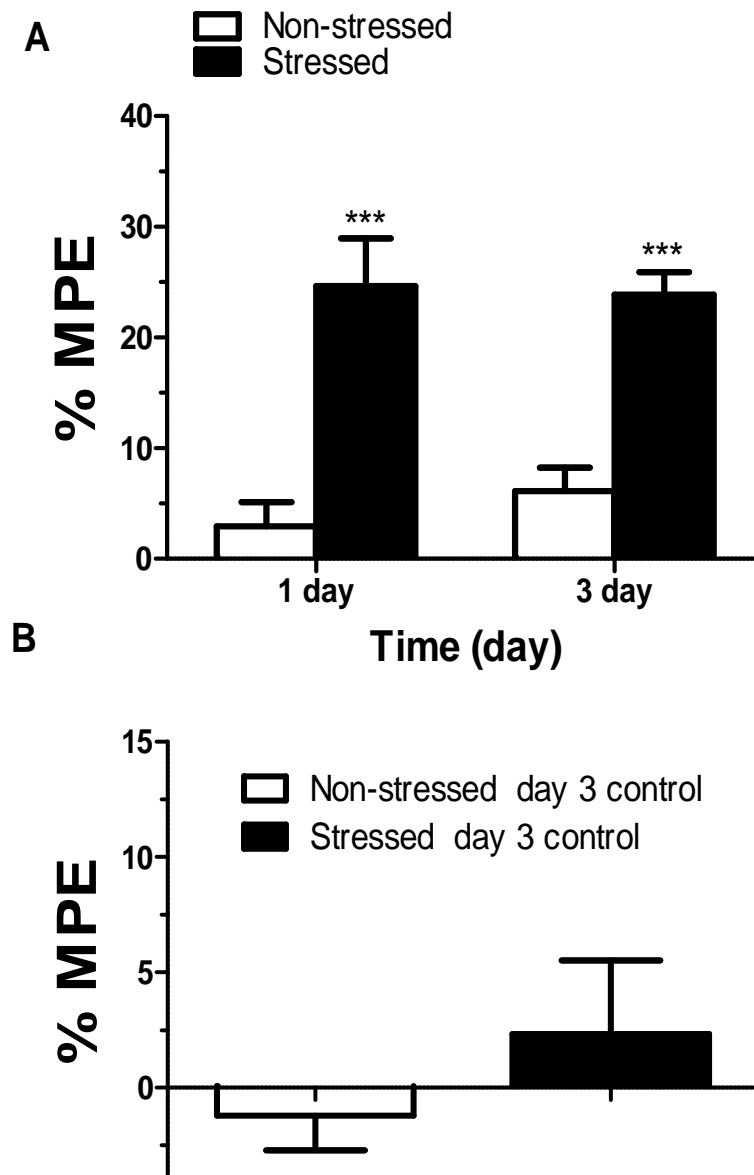

Figure 6.5. (A) Effect of 1 day and 3 day restraint stress (09:00-11:00) on stress-induced analgesia in CD1 male mice. (B) Baseline latency on day 3. Results are expressed as mean \pm SEM, $n=4$. *** $p<0.001$ as compared to non-stressed controls. Analysis done repeated measures mixed model analysis.

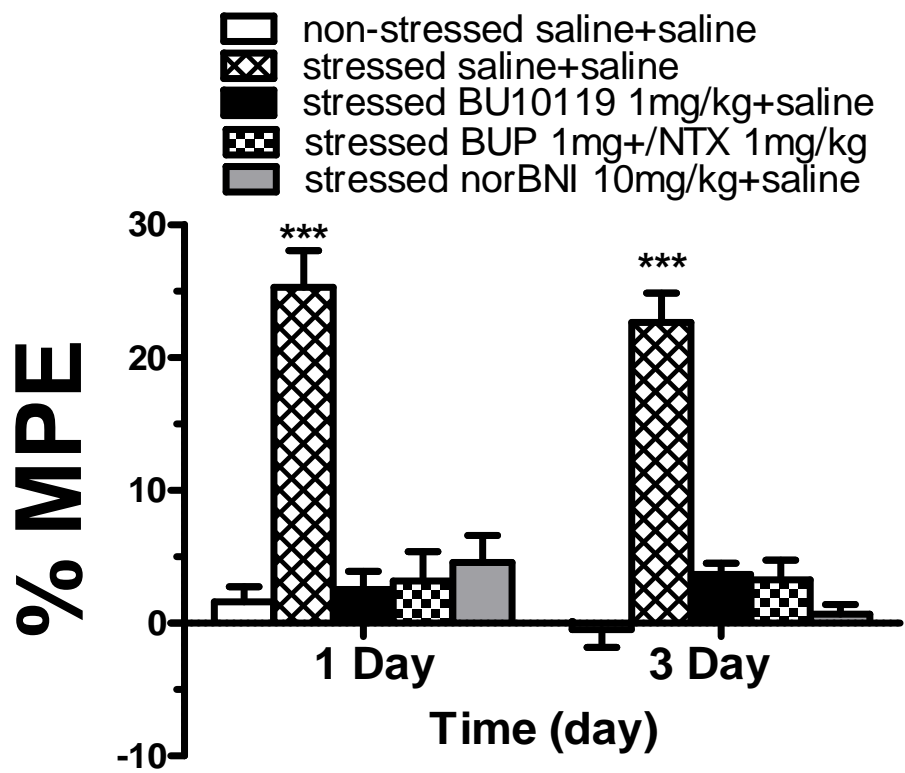
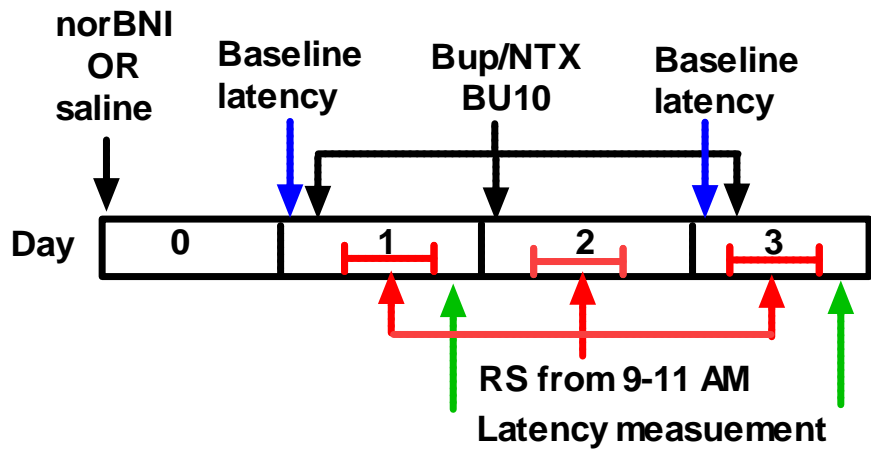

Figure 6.6. Effect of one day and three-day restraint stress (9-11am) on stress-induced analgesia in CD1 male mice. All drug treatments tested blocked stress-induced analgesia. Results are expressed as mean \pm SEM, n=6. ***p<0.001 as compared all groups. Analysis done repeated measures mixed model analysis. RS (Restraint stress).

6.6.3. Effects of restraint stress on behaviour in the elevated plus maze

The effects of 1 and 3 days immobilization for 2 h on behaviours in the EPM are shown in figures 6.7 and 6.8. Using unpaired student t-test, revealed no significant effects of Treatment on the time spent in ($p>0.05$) and number of entries into ($p>0.05$) the open arms in acute and three days restraint. However, there was a significant increase in total locomotion ($p<0.05$) after 3 days repeated restraint stress when compared to non-stressed.

6.6.4. Effects of restraint stress on behaviour in the forced swim test

The effects of 1 and 3 days restraint stress in the FST are shown in (Figure 6.9, $n=10$ per group). Unpaired t-test showed no significant effects of restraint stress on the time spent swimming or immobile in the last 4 min of a 6 min test session ($p>0.05$) and immobile ($p>0.05$) as compared to non-stressed mice.

6.6.5. Effects restraint stress on sucrose preference test (SPT)

Preliminary studies established the effects of bottle position and sucrose concentration in adult CD-1 male mice (Figure 6.10 and 6.11). The position of the sucrose and water bottles were randomly assigned in the cage. There were no significant preference for the position of bottle filled with water placed at front or back of the cage (Figure 6.10, $F_{(5,42)} = 47.81$, $p>0.05$, $n=8$, one way ANOVA). The dose response curve of sucrose preference at 1, 2.5 and 5 % of sucrose in adult male CD1 mice is shown in figure 6.11 ($F_{(5,42)} = 36.28$, $p<0.001$, $n=8$, one way ANOVA). Post hoc comparison revealed that sucrose at 1, 2.5 and 5 % all significantly increased preference for sucrose compared to water ($p<0.05$, $p<0.001$, $p<0.001$ respectively). Also, there was an increase in total consumption as body weight % in 5% sucrose group as compared to the other groups ($p<0.05$). Therefore, 5% sucrose was chosen for future experiment.

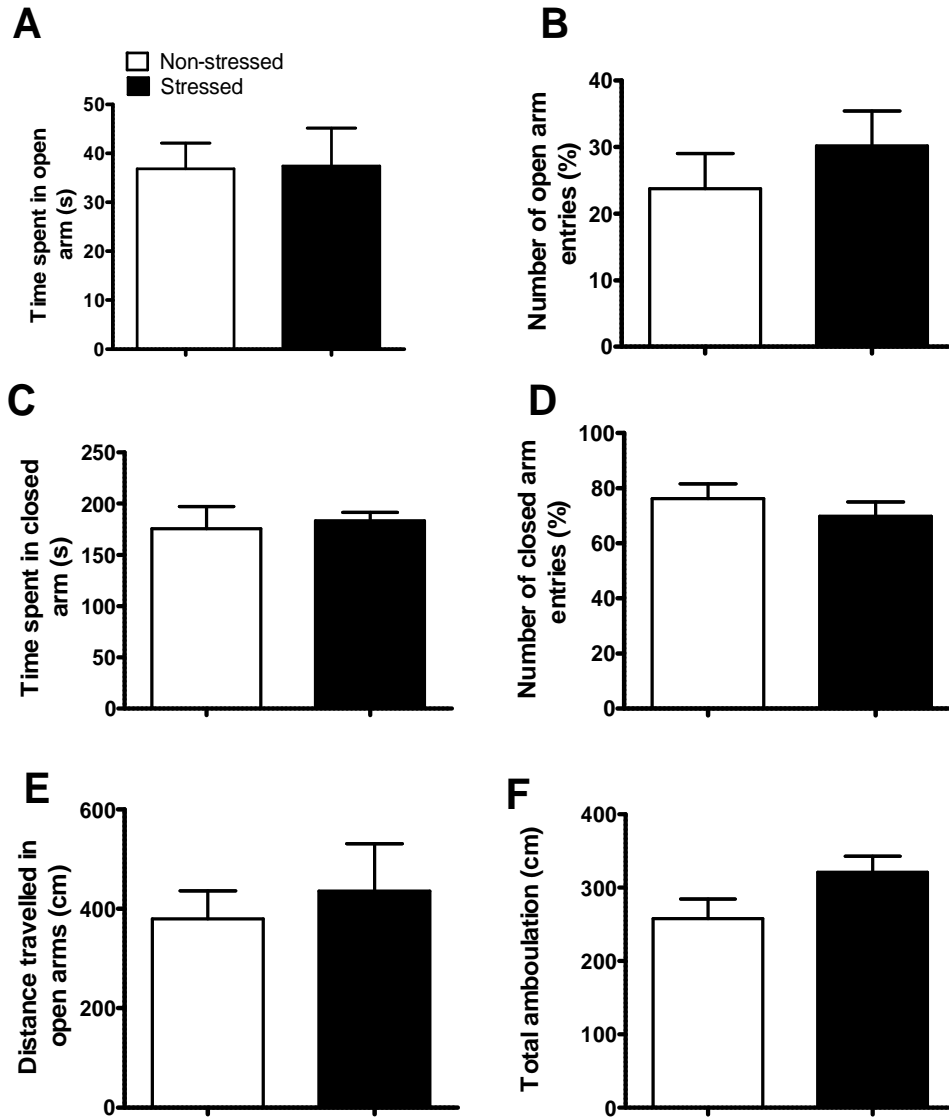

Figure 6.7. Effects of acute restraint stress on behaviour in the elevated plus maze. The time spent in open arm (A), the number of entries into the open arm (B), time spent in the closed arm (C), number of entries in the closed arm (D), distance travelled in open arm (E) and total locomotion (F) was recorded. Each column represents the mean \pm SEM of 10 adult CD1 mice. Analysis was done by unpaired t-test.

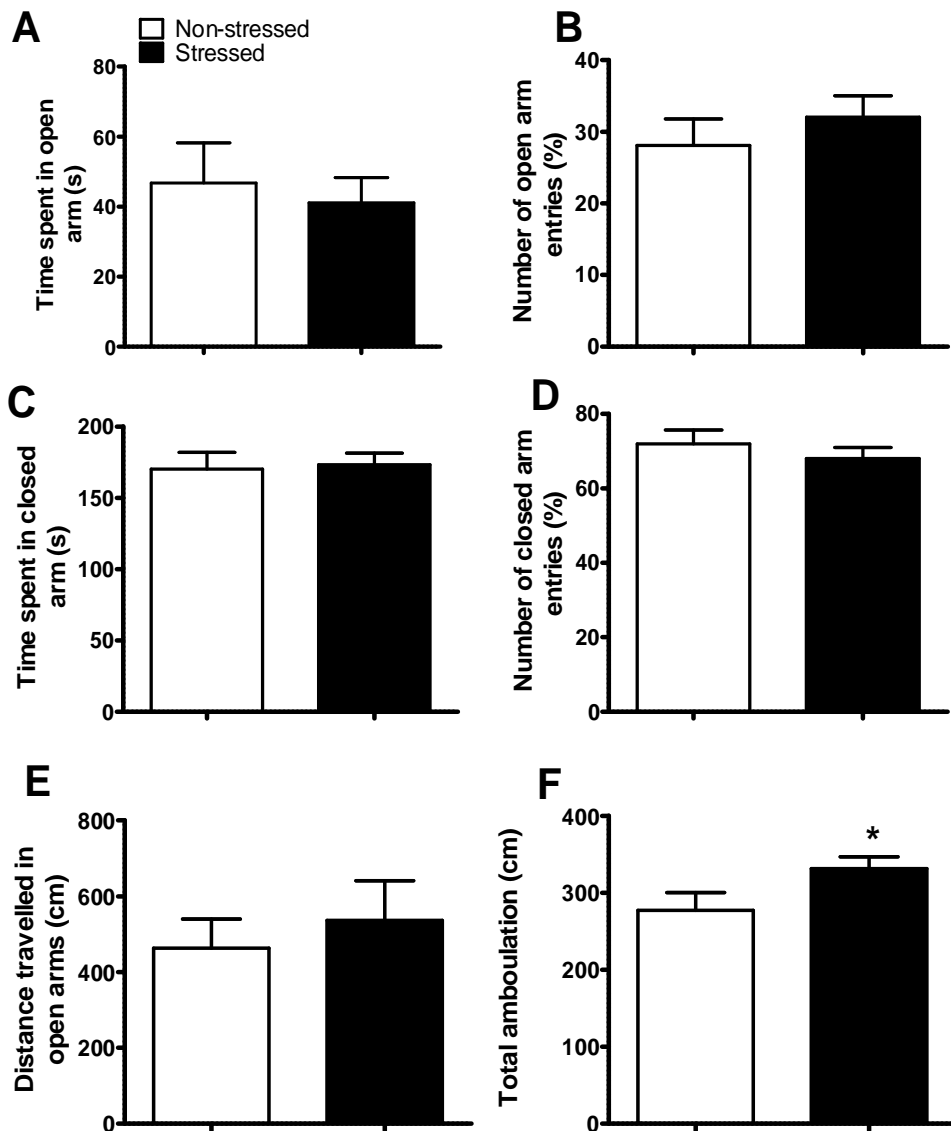

Figure 6.8. Effects of 3 days repeated restraint stress on behaviour in the elevated plus maze. The time spent in open arm (A), the number of entries into the open arm (B), time spent in the closed arm (C), number of entries in the closed arm (D), distance travelled in open arm (E) and total locomotion (F) was recorded. Each column represents the mean \pm SEM of 20 adult CD1 mice. * $p < 0.05$ as compared to non-stressed by unpaired t-test.

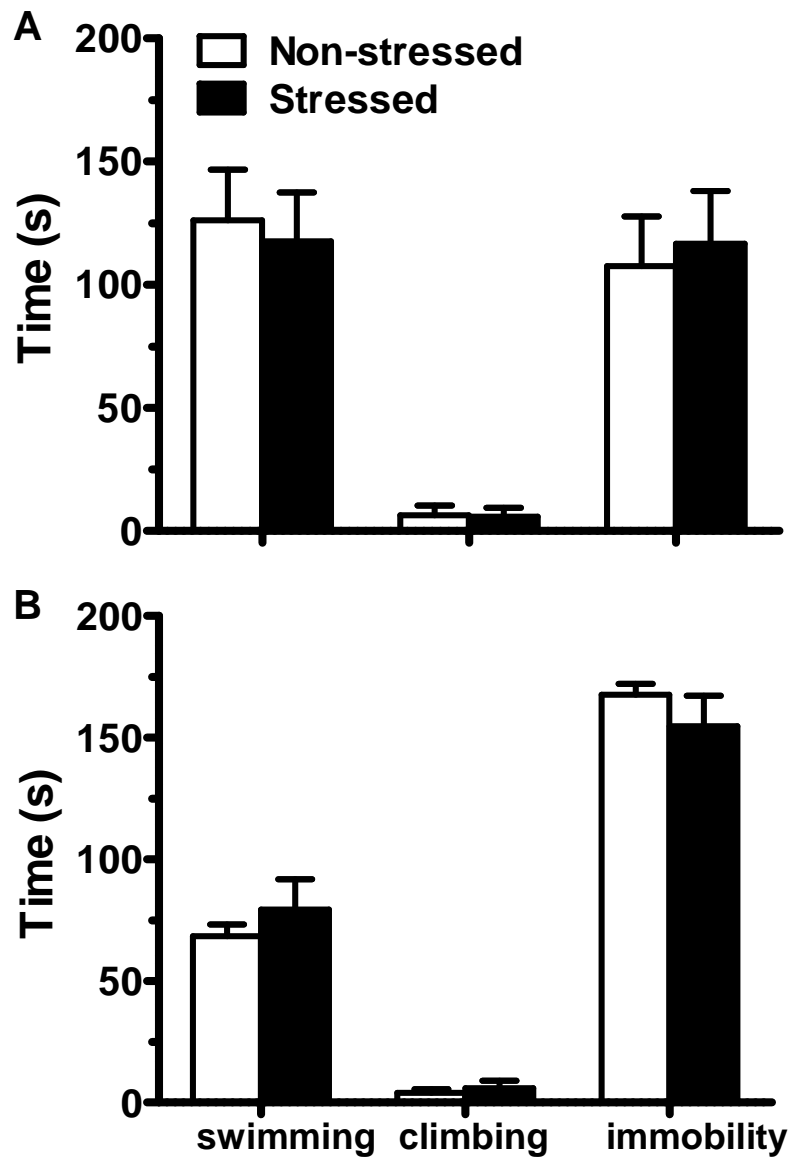
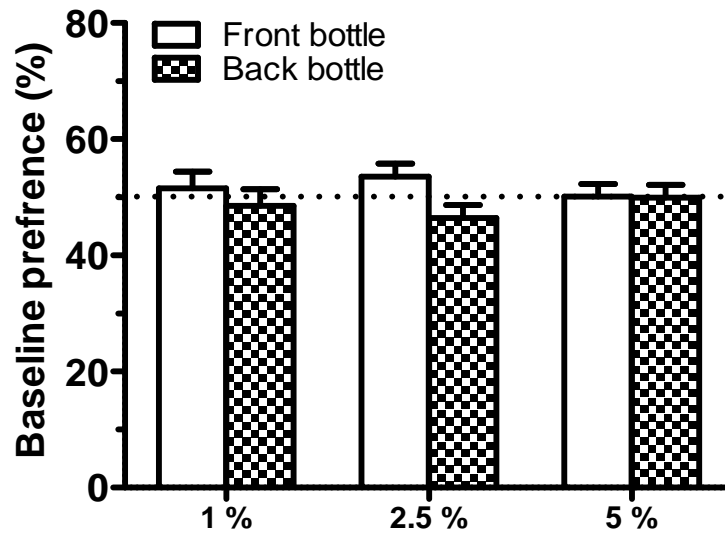

Figure 6.9. Effect of 1 day (A) and 3 days (B) restraint stress on behaviour in the FST in CD1 male mice. Time spent swimming and immobile were recorded in the last 4 minutes of a 6 minute test. Results are expressed as mean \pm SEM, n=10. Analysis was done by unpaired *t*-tests.

A



B

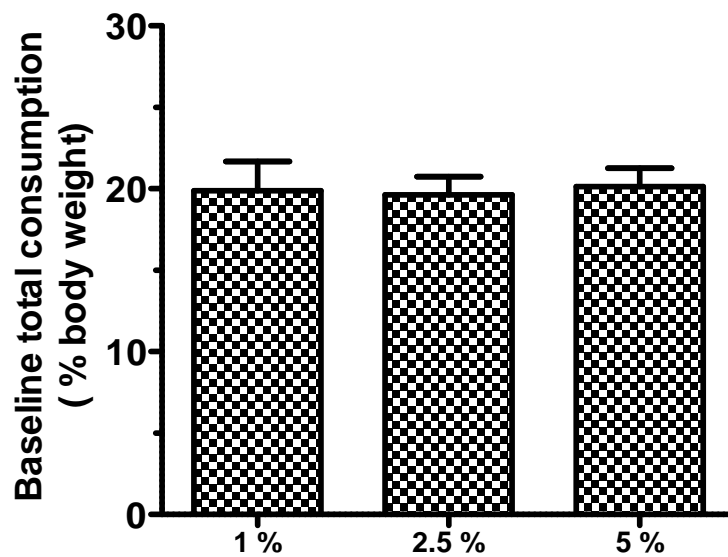

Figure 6.10. Baseline preference for bottle position in sucrose preference test for the front and back bottle (A) and total consumption as body weight % (B) in adult CD1 male mice. Preference was measured over a 12h test period (7pm-7am). Results are expressed as mean \pm SEM, n=8. Analysis was done by one way ANOVA.

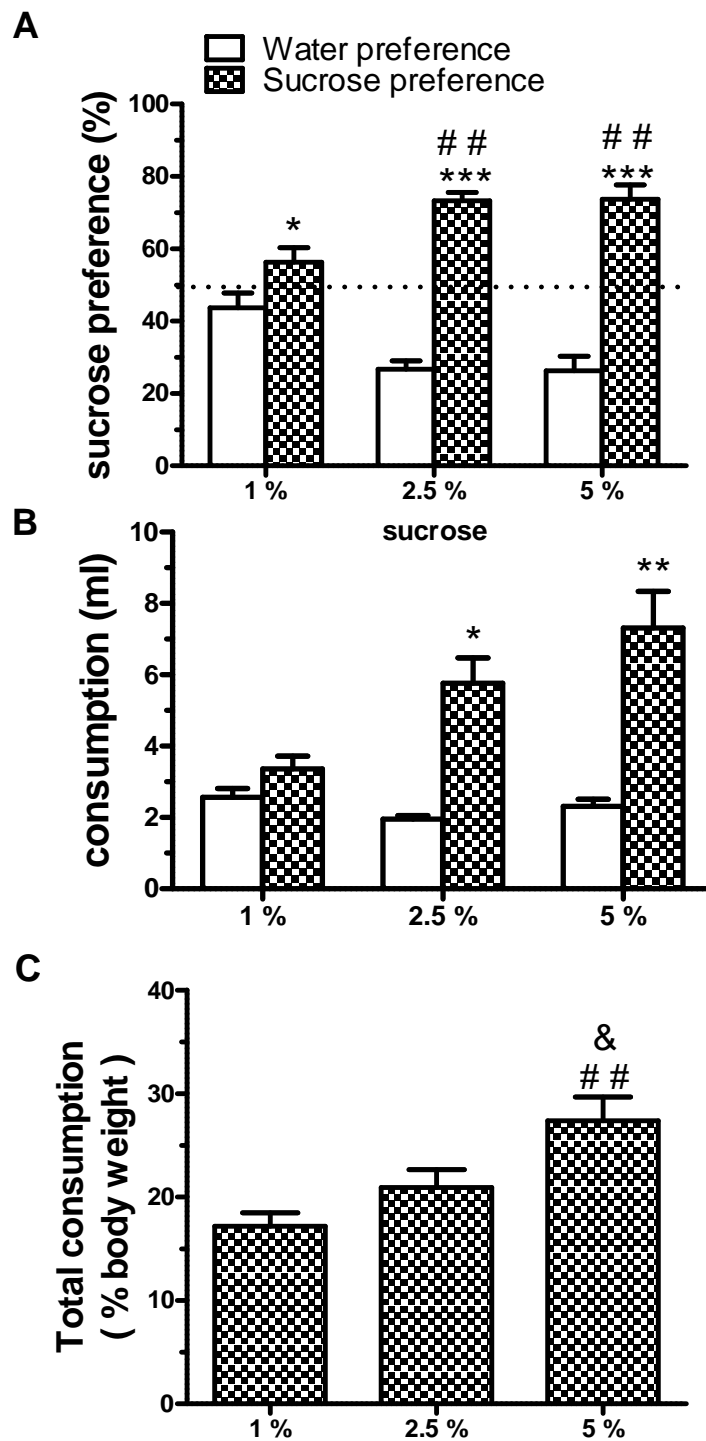

Figure 6.11. Preliminary study to show effects of sucrose concentration on sucrose preference in adult CD-1 male mice . Preference for 1, 2.5 and 5% sucrose solution (A), total consumption of both sucrose and water (B) and sucrose consumption (C) were measured over a 12h test period (7pm-7am). Results are expressed as mean \pm SEM, n=6-8/group. * p <0.05, ** p <0.01, *** p <0.001 as compared to water presence. ## p <0.01 as compared to 1% sucrose. & p <0.05 as compared to 2.5% sucrose. Analysis was done by one-way ANOVA.

The baseline preference for bottle position in 5 % sucrose preference test for the front and back bottle and total consumption for 1 and 3 day stressed and non-stressed groups is shown in figure 6.12 and 6.14. There was no significant difference in baseline measurement of preference from front and back bottle in 1 and 3 day stressed ($p>0.05$, unpaired t-test, $n=8$). Then, the effect of 1 and 3 days restraint stress was assessed in the SPT (Figure 6.13 and 6.15). There were no significant difference in sucrose preference in 1 and 3 day in stressed mice when compared to non-stressed group ($p>0.05$, unpaired t-test, $n=8$). However, there was a significant reduction in total consumption as % of body weight ($p<0.01$, unpaired t-test, $n=8$) and sucrose consumption ($p<0.001$, unpaired t-test, $n=8$) in 1 day stressed mice as compared to non-stressed mice. Since the restraint stress paradigm did not yield a significant change in the anxiety and depression related behaviour it was not possible assess κ -receptor antagonist effects on these behaviours.

6.6.6. Effects of restraint stress on gene expression

One-step RT-PCR was carried out to qualitatively establish the absence or presence of the GOI in PFC, Hip, NAc and Amy tissue isolated from adult CD-1 male mice brains. The GOI analysed were the κ -receptor, Pdyn and CRHR1, while 18s rRNA was used as a house keeping gene.

The expression profile of genes are shown in Figures 6.16 A and B. gel electrophoresis showed a single RT-PCR product of the predicted amplicon size confirming expression of all GOI in these brain regions. In the quantitative real-time RT-PCR experiments, the PCR products were detected by using fluorescent SYBR green. In general, SYBR green binds to all double stranded DNA. Therefore the melting peak analyses was conducted in all experiments to determine whether non-specific binding of additional double-stranded DNA products had occurred. Figures 6.17 A,B,C and D show representative amplification curves, and melting peak

analysis which demonstrate the specific amplification of the housekeeping gene and GOI in PFC region.

Gene expression changes were examined in the PFC, NAc, Hip and Amy of adult CD-1 male mice to determine the effects of 3 days restraint stress and effects κ -receptor antagonist treatment. The restraint stress and κ -receptor antagonist treatment of adult male CD1 mice had no significant effect on the gene expression for all GOI in all regions test ($P > 0.05$, one way ANOVA, Figure 6.18 A,B,C and D).

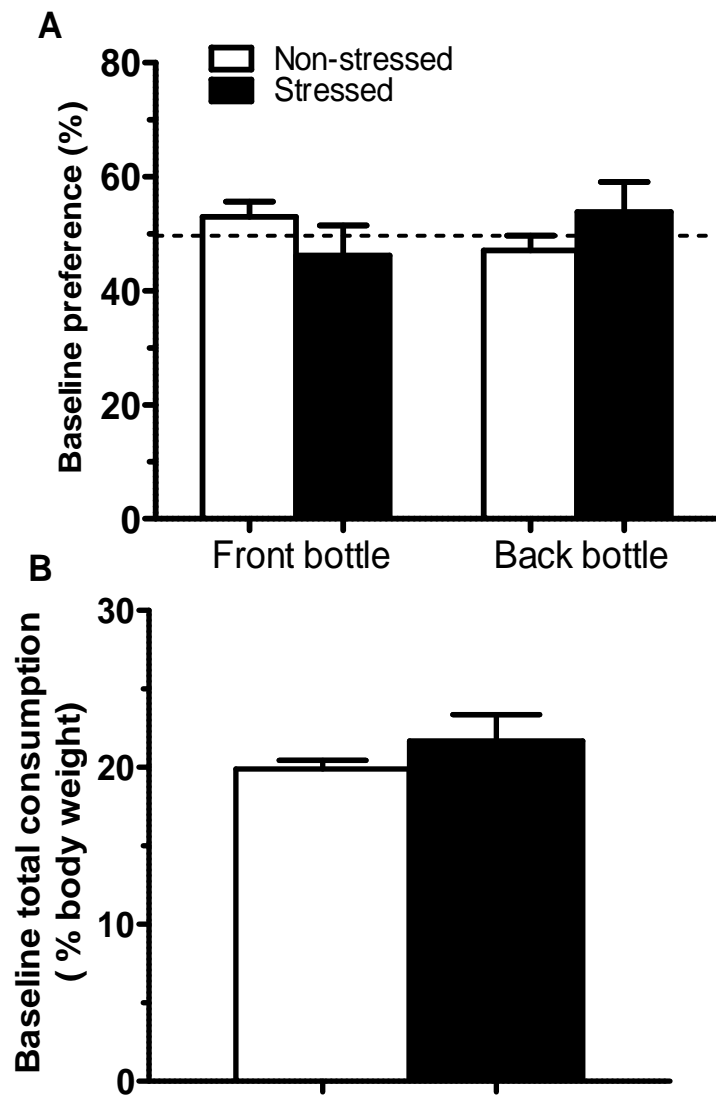

Figure 6.12. Baseline preference for front and back water bottle (A) and total consumption as body weight % (B) in adult CD-1 male mice before 1 day restraint stress. Preference was measured over a 12h test period (19:00-07:00 h). Results are expressed as mean \pm SEM, n=8. Analysis was done by unpaired t-test.

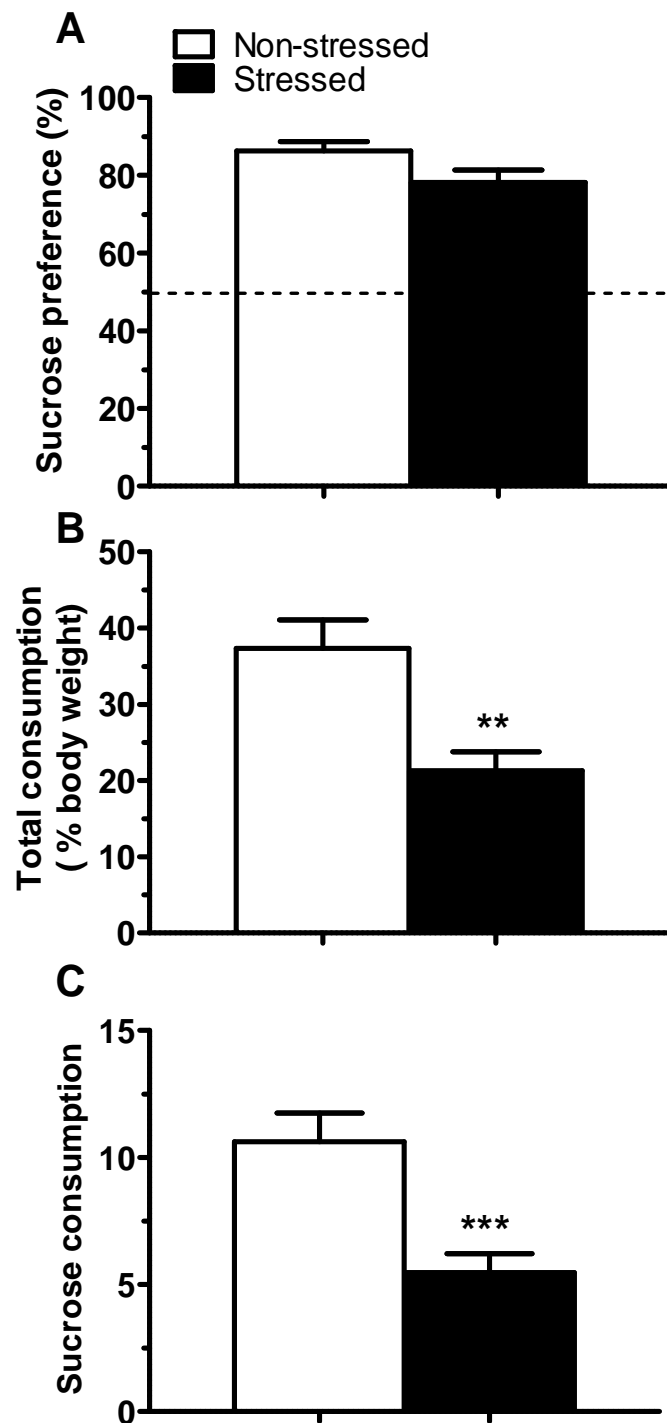

Figure 6.13. Effects of 1 day restraint stress on sucrose preference in adult CD-1 male mice. Preference for 5% sucrose solution (A), total consumption of both sucrose and water (B) and sucrose consumption (C) were measured over a 12h test period (19:00-07:00 h). Results are expressed as mean \pm SEM, $n=8$. ** $p<0.01$, *** $p<0.001$ as compared to non-stressed group. Analysis was done by unpaired t-test.

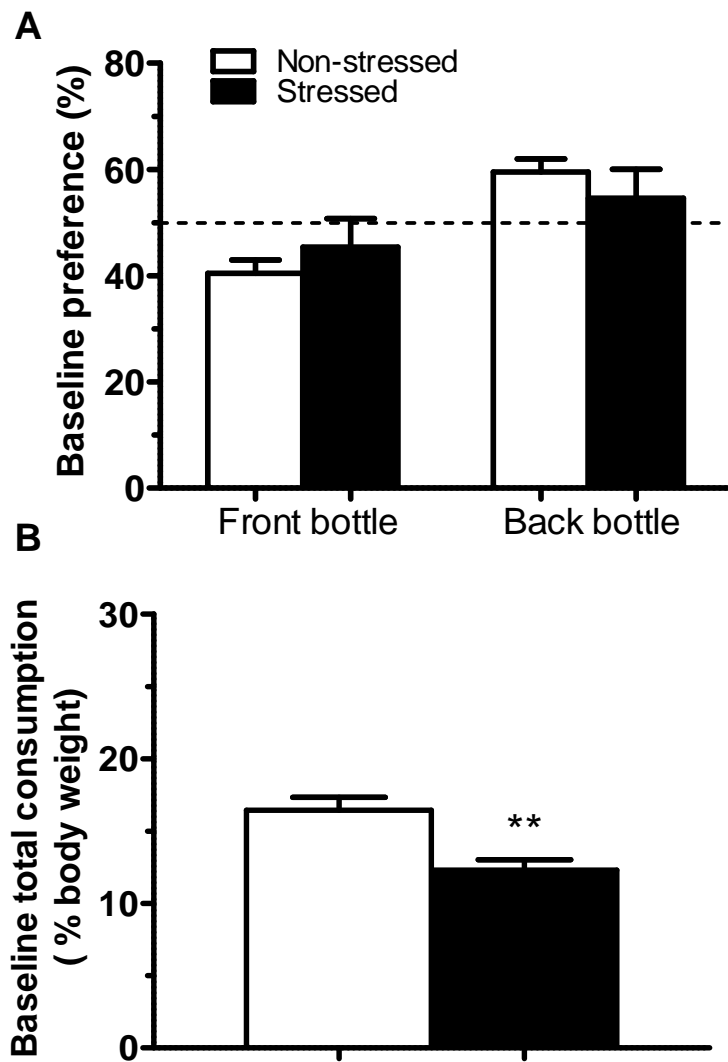

Figure 6.14. Baseline preference for front and back water bottle (A) and total consumption as body weight % (B) in adult CD-1 male mice. Preference was measured over a 12h test period (19:00-07:00 h). Results are expressed as mean \pm SEM, n=8. **p<0.01 as compared to non-stressed group. Analysis was done by unpaired t-test.

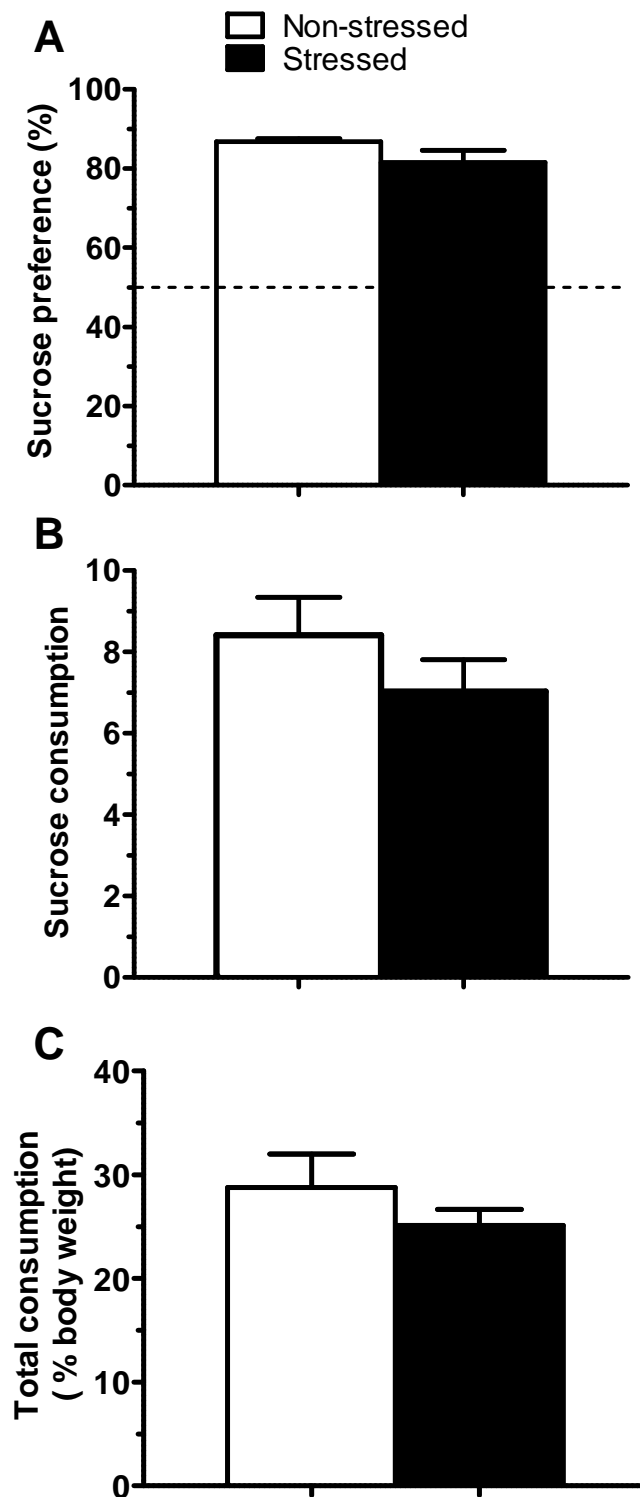

Figure 6.15. Effects of 3 days restraint stress on sucrose preference test in adult CD-1 male mice. Preference for 5% sucrose solution (A), total consumption of both sucrose and water (B) and sucrose consumption (C) were measured over a 12h test period (19:00-07:00 h). Results are expressed as mean \pm SEM, n=8. Analysis was done by unpaired t-test

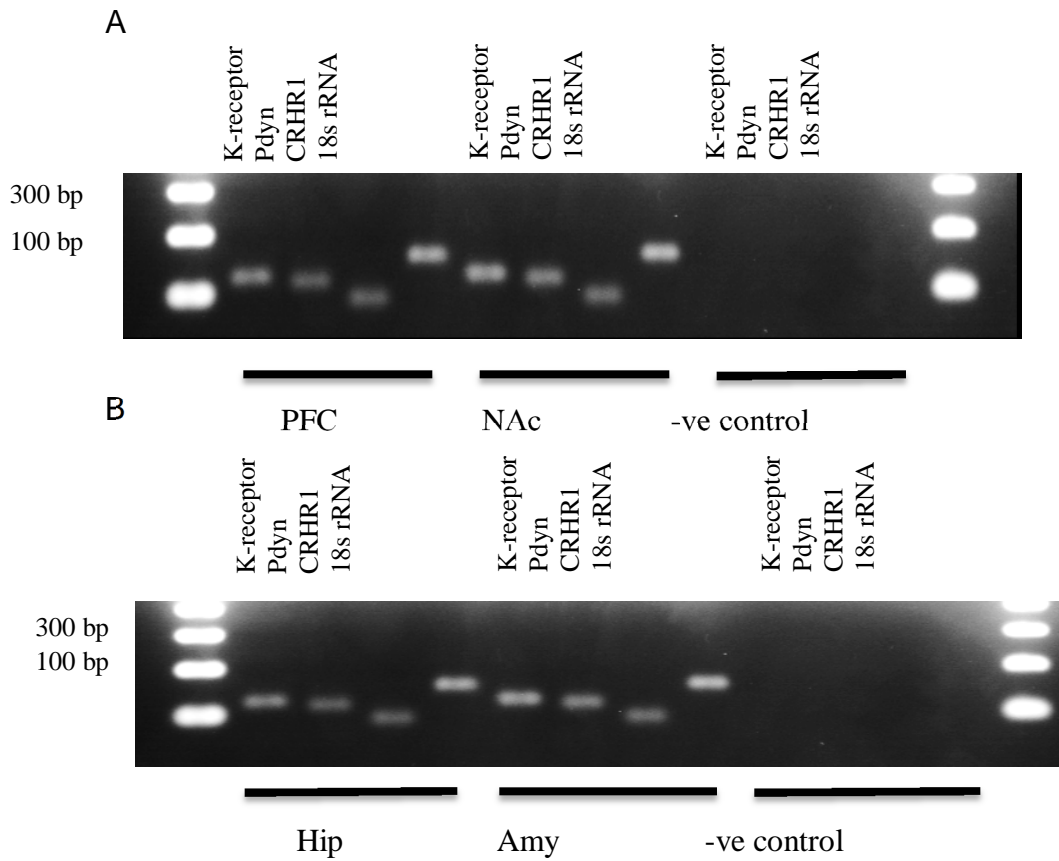

Figure 6.16. Expression of kappa-receptor (k-receptor), prodynorphin (Pdyn) and corticotropin-releasing hormone receptor1 (CRHR1) mRNAs in adult CD-1 male mice in prefrontal cortex (PFC), nucleus accumbens NAc (A) hippocampus (Hip) and amygdala (Amy) (B). One-step RT-PCR with gene specific primers.

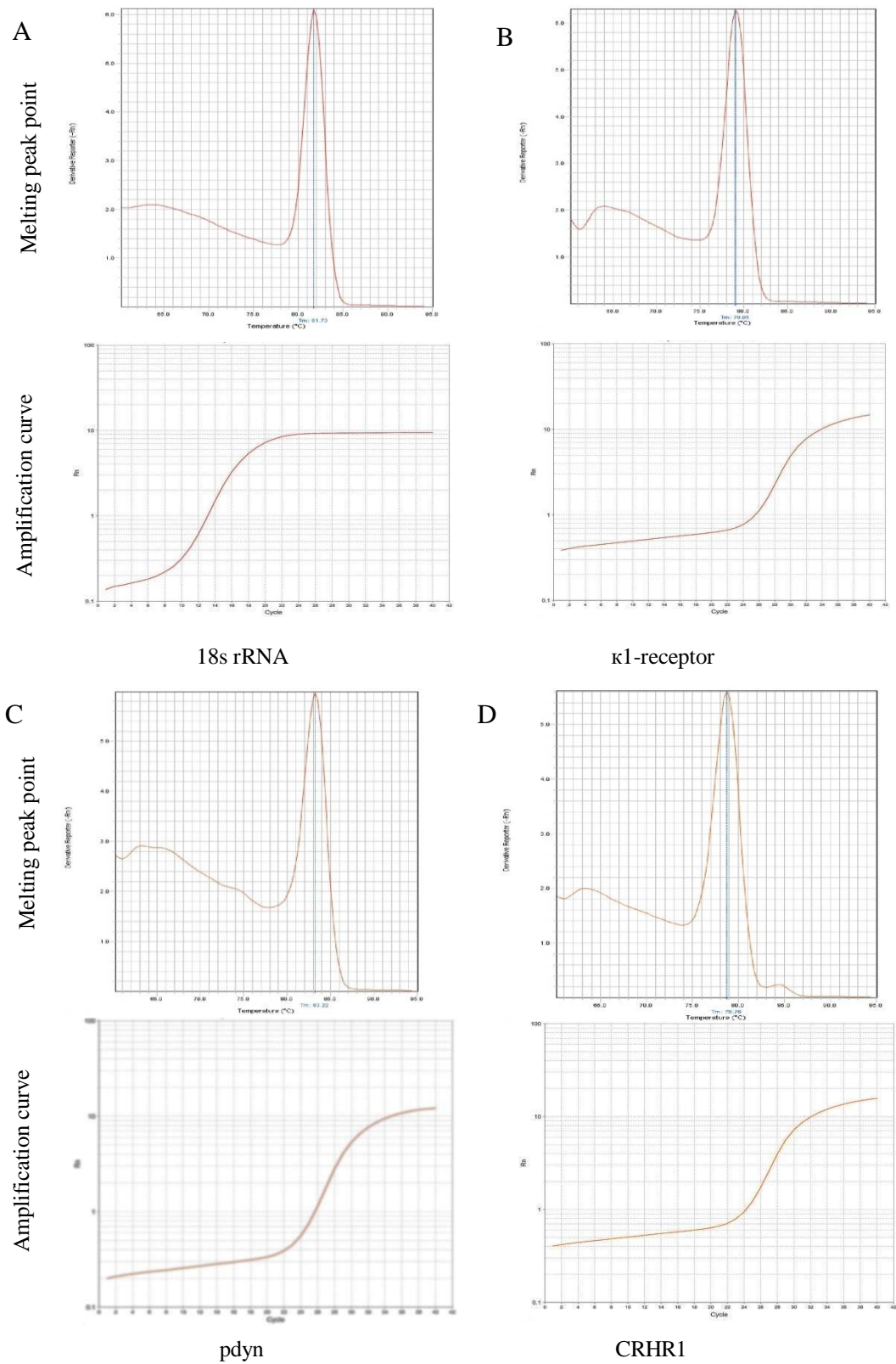

Figure 6.17. Quantitative real-time RT-PCR amplification and melting points using 18s rRNA (A), κ -receptor (B), Pdyn (C) and CRHR1 (D) primers in vehicle non-stressed adult CD-1 male mine in PFC tissue. Amplification curves shows increasing fluorescence on x-axis and PCR cycle number over 40 cycle of PCR amplification. Melting curves shows $\Delta f/dt$ on x-axis and decreasing temperature (95-60°C).

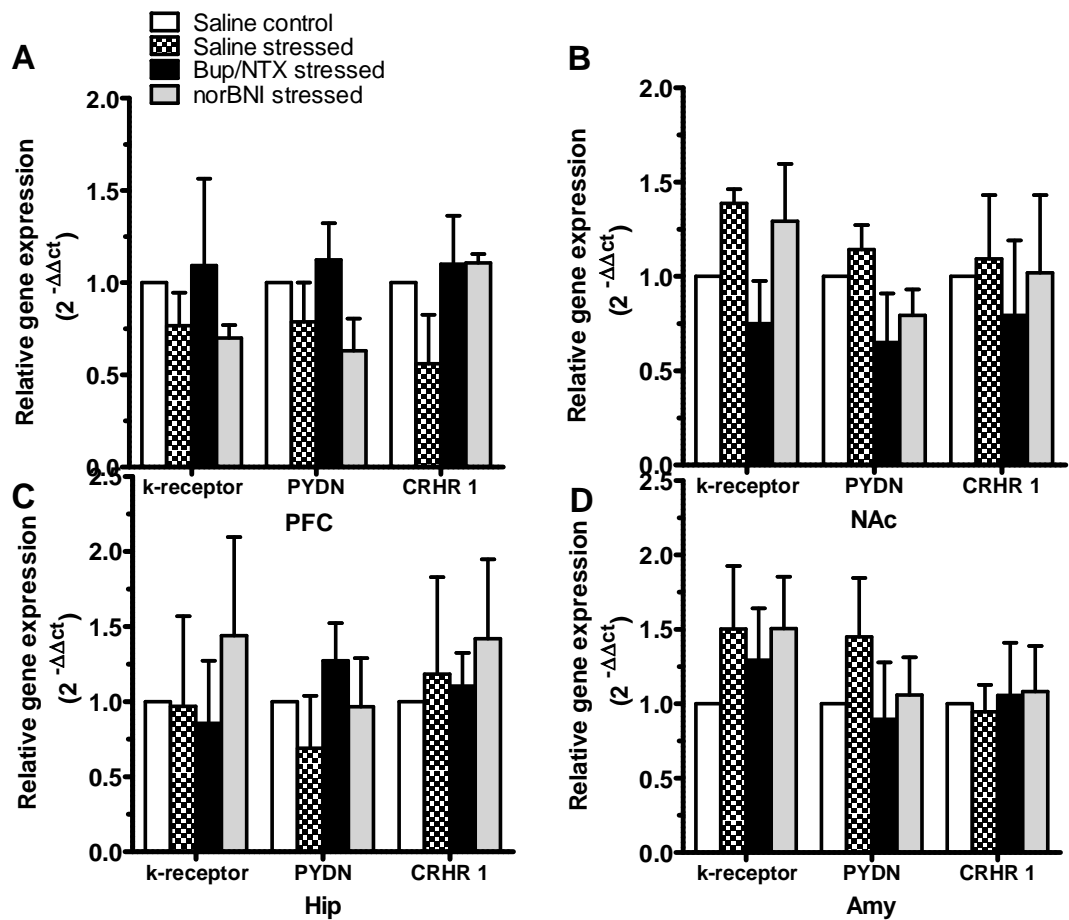

Figure 6.18. Relative fold changes of κ -receptor, Pdyn and CRHR1 gene expression in repeated 3 day restraint stress adult CD-1 male mice in PFC (A), NAc (B), Hip (C) and Amy (D). Gene changes are relative to non-stressed control group and normalized to housekeeper gene (18s rRNA). Results are expressed as mean \pm SEM, n=3. Analysis was done by one-way ANOVA.

6.7. Discussion

In this chapter, 1 day and 3 days restraint stress significantly increased plasma corticosterone levels and induced analgesia in adult CD-1 male mice. Pretreatment with buprenorphine/naltrexone (1 mg/kg), BU10119 (1 mg/kg) or norBNI (10 mg/kg) (given 24 hr before restraint stress) failed to block the increase in plasma corticosterone observed after 3 days of stress. However, pretreatment with these drugs was able to block restraint stress-induced analgesia evident after 1 and 3 days restraint stress. In addition, there was little change of behavioural changes caused by restraint stress on EPM, SPT, and FST as compared to non-stressed groups. Moreover, 3 days restraint stress did not produce any significant changes in the relative expression of the κ -receptor, Pdyn and CRHR1 gene in PFC, NAc, Hip and Amy when compared to non-stressed adult CD-1 male mice.

Our data are in agreement with numerous studies documented that acute and chronic physical and/or psychological stressors such as foot shock and restraint causes a significant several fold increase in corticosterone level in mice (Rademacher et al., 2008; Sadler and Bailey, 2013; Ide et al., 2010; Gong et al., 2015) and in rat (Foilb et al., 2011). The baseline corticosterone values obtained here are within the range reported by others in mice (Ide et al., 2010; Sadler and Bailey, 2016). In this study, 1-day and 3 days repeated restraint stress demonstrated that this procedure increased the activity of the hypothalamus-pituitary-adrenal (HPA) axis and caused an increase in the secretion of corticosteroids from the adrenal cortex. Because of that, corticosterone is usually used as an index for stress and depressive disorders (Chen et al., 2005; Armario, 2006; Zhang et al., 2011). In this study, it is the first time that buprenorphine/naltrexone combination and BU10119 were tested to investigate its effects on restraint stress-induced elevation in corticosterone level. Pretreatment with these κ -antagonist failed to block the increased in plasma corticosterone by restraint stress. This is in agreement with previous studies (McLaughlin et al., 2006b; Polter et al., 2014) that found out that the prodynorphin knockout mice and the classical κ -receptor antagonist norBNI (10mg/kg) did not block force

swim stress-induced increase in corticosterone levels in mice. On the other hand, norBNI (5 mg/kg) was effective in blocking U50,488H (15 mg/kg) induced an increase in the corticosterone in rat (Alcaraz et al., 1993; Victoria et al., 1994). norBNI dose, time of injection and different stress procedures used could explain the lack of norBNI response in blocking the restraint stress increase in corticosterone levels and by increasing the dose and giving norBNI for longer periods before restraint might result in enhancing its protective effect.

Several studies have documented that acute and strong psychological or physical stressors causes a reduction in pain sensation, a phenomenon named stress-induced analgesia. On the other hand, chronic exposure to such stressors that could be anticipatory/anxiogenic in nature, results in less well understood phenomenon of stress-induced hyperalgesia in rodents (Andre et al., 2005; Quintero et al., 2011; Tramullas et al., 2012; Jennings et al., 2014). In this study, 1 day and 3 days restraint stress led to SIA in adult CD-1 male mice and pretreatment with the short and long acting κ -antagonist blocked SIA. This is consistent with previous studies (Kavaliers and Innes, 1987; Miller, 1988; Butler and Finn, 2009). It is assumed that severe stress produces more prominent analgesia and that's why SIA is an important tool as it helps in the measurement of a subjective amount of stress (Kurrikoff et al., 2008) and preventing this phenomenon with κ -receptor antagonists contribute in understanding the role of stress, κ -receptor and dynorphins in depressive disorders. Moreover, the effectiveness of κ -receptor antagonists to block SIA shows their possibility to be used in prophylactic stress situations.

It has been reported that psychological or physical stressors such as restraint stress, exposure to rat, foot shock and tail suspension stressors causes anxiogenic behavior in rodents by increasing time spent in the closed arms and reduce exploratory activity in the open arms of an EPM (Guimaraes et al., 1993; Solomonow and Tasker, 2015), decrease in sucrose preference (Strekalova et al., 2004; Ferland et al., 2014) and

increased immobility in a FST (Strekalova et al., 2004; Sevgi et al., 2006; Poleszak et al., 2006). However, our results showed little changes in behavioural paradigms after restraint stress. First, there was an increase in locomotion after 3 days of repeated restraint stress on adult CD-1 male mice when tested in EPM as compared to control group. This is in agreement with Zimprich et al (2014) who reported that restraint stress for 2 hr significantly increased the distance travelled in open field when compared to non-stressed mice. The increased locomotor activity seen in both tests could be explained by an increase in an effort to escape the aversive environment (Mozhui et al., 2010). Moreover, Zimprich et al (2014) and Sadler and Bailey (2016) suggested that the increased in total locomotion seen in open field after restraint stress could be used as a marker of stress-responsivity in mice. Secondly, after 1 day of restraint stress there was significant reduction in total and sucrose consumption when compared to non-stressed control. However, after 3 day repeated restraint stress these effects were not reproducible. In addition, there were no significant decreases in sucrose preference in 1 and 3 day restraint stress. In the other parameters in EPM and other behavioural paradigms, our results showed no changes after restraint stress compared to non-stressed mice and this is in controversy with other studies which shows a significant decrease in open arm exploration in EPM (Guimaraes et al., 1993; Solomonow and Tasker, 2015) in sucrose preference (Strekalova et al., 2004) and increase in immobility time in FST after restraint stress (Sevgi et al., 2006). One interpretation of our results is that the stress produced by 1 and 3 days restraint stress is equivalent to the stressed induced by the behavioural paradigms and there is no additive effects gained by restraint stress. The controversy between our result and others can be explained by using different strain, species and type of stress. In addition, the different in the timing of starting the behavioural test after stress may account for this controversy. Indeed, Padovan and Guimaraes (2000) tested several groups of rats consisted of 1, 2, 24 or 48 h after the 2h period of acute immobilization. An additional group was restrained daily for 2 h for 7 days, and tested in the plus-maze 24 h after the last restraint period. They, reported that restraint stress produce

behavioral changes, expressed as a deficit in open and enclosed arm exploration of an EPM 24 or 48 h later, but not 1 or 2 h, after stress.

It is known that brain areas such as the PFC, Hip, NAc, and Amy, are important regions involved in the stress response and regulation of emotion and behaviour (Spear, 2000; Mitra et al., 2009). It has been reported that stressing rats with Fear-Potentiated Startle test upregulates κ -receptor mRNA in the basolateral Amy by 65% and downregulated it in the striatum by 22%, without affecting κ -receptor levels in Hip, or dynorphin levels in any region (Knoll et al., 2011). Moreover, Chartoff et al (2009) reported that FST in rats activates dynorphin expression in NAc tissue and desipramine reduced it. Moreover, it was reported by Falcon et al (2016) that the exposure to unpredictable chronic mild stress for 3 weeks in mice significantly altered opioid gene expression in a number of brain regions (κ -receptor increased in striatum and decreased in Amy and reduced Pdyn in Hip. On the other hand, our result in the relative gene upregulated/downregulated expression study revealed no significant changes after 3 days restraint stress in all different regions tested. The controversy between our behavioral studies and gene expression to other studies could be explained by using different strain, species, duration of stress, starting time of experiment after exposure of stress and methods used. Perhaps the duration of stress and the intensity of stressor are not sufficient in our study to produce the expected changes in adult male CD1 mice.

In summary, buprenorphine/naltrexone (1 mg/kg), BU10119 (1 mg/kg) and single dose of norBNI (10 mg/kg) pretreatment were able to block SIA in adult male CD1 mice. However, they were not capable of blocking restraint stress induce elevation of corticosterone level. Moreover, there were few significant differences between stressed and non-stressed mice in EPM, SPT but not in FST. Moreover, gene expression of κ -receptor, Pdyn and CRHR1 were not significantly altered by restraint stress or κ -receptors antagonist treatment.

Chapter 7

General discussion

7.1. General Discussion

The goal of this thesis is to investigate the effects of systemic administration of buprenorphine (1 mg/kg) and naltrexone (1 mg/kg), buprenorphine/naltrexone (1 mg/kg) combination and BU10119 (1 mg/kg) for its possible antidepressant and anxiolytic-like effects and whether they function as short or long-acting κ -receptor antagonist in adult CD-1 male mice. All of these treatments produced antidepressant-like effects in FST and NIH. Interestingly, they were without significant effect on anxiety-related behaviours in the EPM and LDB. Moreover, it was established that the combination dose of buprenorphine/naltrexone (1 mg/kg) functions as a short-acting κ -antagonist in the tail withdrawal test. Also, BU10119 (1 mg/kg) was found to be a functional κ -receptor antagonist with a rapid onset and a duration of action not more than 24 hours. Furthermore, the combination dose was neither rewarding nor aversive in the CPP paradigm. In addition, the combination regimen and BU10119 were neither hyperactive nor sedative in locomotor activity assay and their actions were not mediated throughout by a general sedation. Moreover, buprenorphine/naltrexone (1 mg/kg) combination and BU10119 (1 mg/kg) were able to block stress-induced analgesia in adult CD-1 male mice. However, the antagonists were not capable of blocking restraint stress-induced elevation of corticosterone level. The potential of these antagonists to block stress-induced behavioural effects could not be determined in this study since acute restraint stress did not induce depressive and anxiogenic-like effects in behavioural paradigms compared to non-stressed adult CD-1 male mice.

7.2 Clinical potential of buprenorphine/naltrexone and BU10119

These results are consistent with the growing literature which indicates that κ -receptor antagonists could be beneficial in the treatment and prevention of mood disorders through blockade of dynorphin's negative consequences (Shirayama et al., 2004; Mague et al., 2003; Filho et al., 2013; McLaughlin et al., 2003). Indeed, preclinical studies have consistently shown that activation of the κ -receptors has pro-depressant-related effects (Bals-Kubik et al., 1993; Shirayama et al., 2004), whereas disruption of κ -

receptors signalling via κ -receptors or dynorphin knockouts and blockade with κ -receptors antagonists has antidepressant and anxiolytic-related effects (Wittmann et al., 2009).

The existing literature on κ -receptor antagonists has widely used JDTic and nor-BNI that exhibit long-lasting pharmacokinetic properties, they inhibit receptor signalling for weeks to months after a single dose (Béguin and Cohen, 2009), that complicate experimental design and interpretation of results. Moreover, JDTic was stopped during phase I human clinical trials due to the development of non-sustained ventricular tachycardia (Buda et al., 2015). However, the mechanism of this adverse effect is not clear. One possible explanation is that JDTic activate c-Jun N-terminal kinase (JNK) which may in turn cause disturbance in fatty acid oxidation in a human ventricular and cause cardiac dysfunction. Also, the unusual long-lasting effects of some κ -receptor antagonists has been attributed to their ability to activate the JNK signalling pathway (Bruchas and Chavkin, 2010; Melief et al., 2011) (see figure 7.1 and 7.2). In addition, it has been suggested that κ -receptor antagonists that do not activate JNK could be safer alternatives. The LY2456302 compound, which was produced by Eli Lilly, is an example of a κ -receptor antagonist that does not strongly activate JNK. The authors in their recent phase I trial reported that the product was well-tolerated (Lowe et al., 2014). Moreover, the nonselective κ -receptor antagonists, buprenorphine and naltrexone are licensed in the market for other indications (treatment of opioid dependence) and clinical experiences with them have rarely reported this adverse effect and this is one of the potential advantages of this combination. Also, ALKS-5461 which is a combination of buprenorphine and samidorphan (μ -receptor antagonist) acting as a κ -receptor antagonist, which is under development by Alkermes for the treatment-resistant depression (Ehrich et al., 2015). Their results in phase II were very promising and researchers have reported that ALKS-5461 might work well for the treatment of major depression. In their study they evaluated the effects of buprenorphine (2,4 and 8 mg), in 8:1 and 1:1 dose ratios with

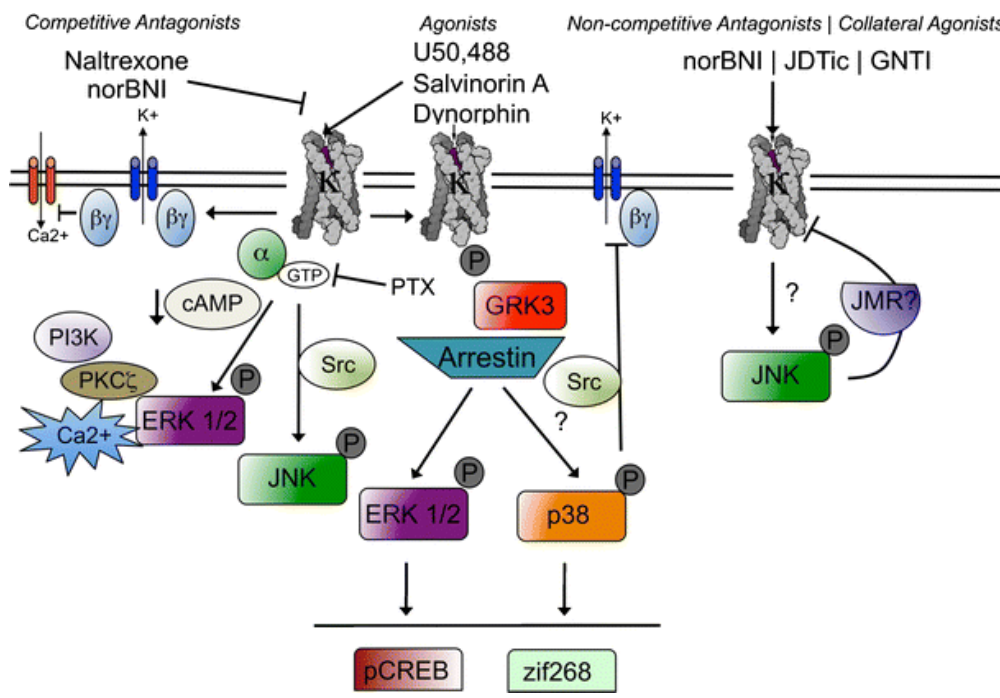

Figure 7.1. K-receptor mediated signal transduction pathways. Activation by of κ-receptor can result in activation of several kinase cascades. Arrows refer to activation steps, T lines refer to blockers or inhibition of function. Abbreviations are as follows: α G-protein alphasubunit, arrestin phosphorylationdependent GPCR scaffold, βγ G-protein beta-gamma subunit, cAMP cyclic adenosine monophosphate, ERK 1/2 extra-cellular signalregulated kinase, GRK3 G-protein coupled receptor kinase3, JMR JNK Modulated Regulator, JNK c-Jun N-terminal Kinase, p38 p38 MAPK, P phosphorylation, pCREB phospho-cyclic AMP response element binding protein, PI3K phosphoinositol 3-kinase, PKCζ protein kinase C zeta, PTX pertussis toxin, Src short for sarcoma, member of the src family tyrosine kinases, zif268 transcription factor, also called Egr-1. (Reference: Bruchas and Chavkin, 2010).

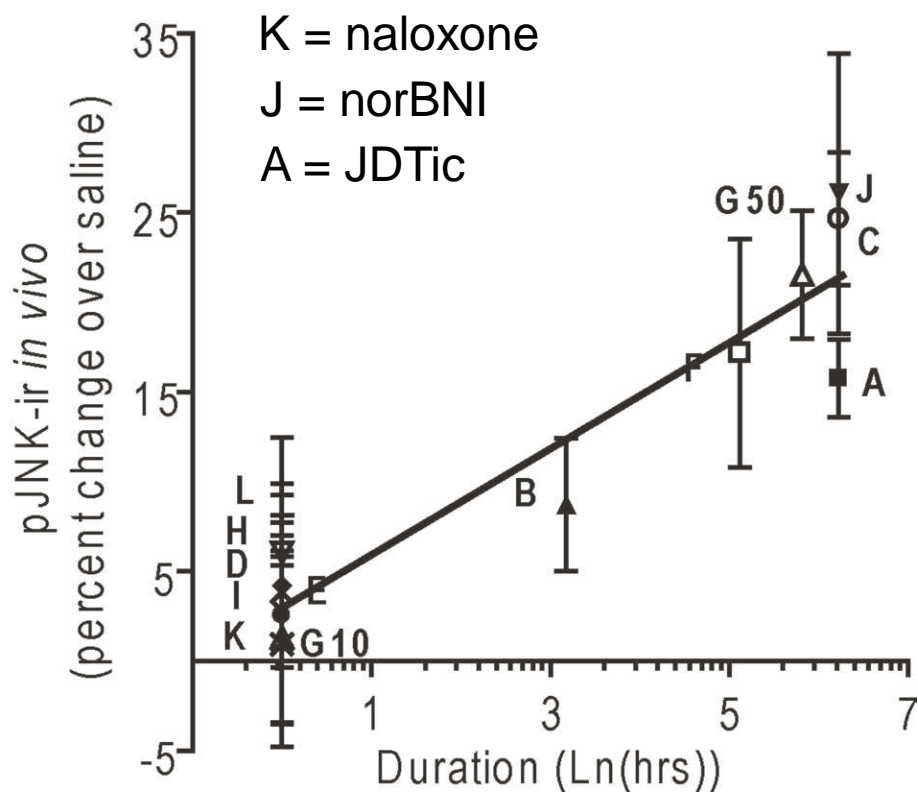

Figure 7.2. Efficacy of JNK activation correlates with duration of action. Quantification of pJNK-ir from Western blots was plotted as a function of the natural log of duration of antagonism for each compound. Natural log was used to transform the x values because the recovery of response after receptor inactivation follows the asymptotic kinetics of receptor expression approach to equilibrium. (Reference: Melief et al., 2011).

samidorphan, as adjunctive therapies in a small cohort of adult subjects with major depressive disorder. Patients had a current episode of depression and experienced inadequate response to antidepressant treatment. After 7 days of once daily buprenorphine/ samidorphan, at a 1:1 ratio, depressed patients exhibited a statistically significant improvement in HAM-D17 total score versus placebo, with an effect size of 1.49 (Ehrich et al., 2015). In addition, the data from two of three core Phase III trials was recently released and revealed that the combination was safe and well tolerated. However, it failed to meet its primary efficacy endpoints, although some efficacy was observed. The third and final core Phase III study is currently in progress. However, they suggested that the buprenorphine/samidorphan combination is a novel and potential treatment for major depressive disorder in patients who are treatment-resistant with standard antidepressants (Fava et al., 2016).

In this study, it has been shown that the combination of buprenorphine (1 mg/kg) with naltrexone (1 mg/kg) and BU10119 (1 mg/kg) administered intraperitoneally in adult CD-1 male mice has antidepressant potential. Buprenorphine and naltrexone are licensed currently for other indications, so may be attractive to translate to the clinic. However, naltrexone is administered orally and buprenorphine sublingually, so achieving the correct dose combination to achieve an antidepressant effect may not be trivial. Cordery et al (2014) have suggested that the ideal buprenorphine: naltrexone plasma concentration ratio is around 1:5 for anti-addiction treatment. Further, they suggested that higher doses of both buprenorphine and naltrexone than those used by Rothman et al (2000) and Gerra et al (2006) for treatment of opioid dependence (buprenorphine 4 mg daily/ naltrexone 50 mg daily) may be even more effective clinically, as the combination would result in greater receptor occupancies. In preclinical studies, lower doses of buprenorphine at 0.25 and 0.5 mg/kg have been shown to have antidepressant-like effects in mice (Falcon et al., 2015), in comparison to 1 mg/kg used in this study which also produced antidepressant-like effects. Interestingly, clinically significant effects of buprenorphine have been observed at lower doses, with the titrated dose

ranging from 0.15 mg/d to 1.8 mg/d or from 0.2 mg/d to 1.6 mg/d (Bodkin et al., 1995; Karp et al., 2014). Naltrexone would need to be carefully titrated to avoid inducing aversive side effects which deter use (Bouza et al., 2004). A further limitation of this combination approach is the risk of diversion of buprenorphine and its abuse liability. Also, buprenorphine and naltrexone could not be administered as a single formulation due to their different bioavailability, which might create compliance issues. Nevertheless, these data highlight the potential of combination buprenorphine/ naltrexone as an antidepressant treatment strategy and to provide an alternative route to achieving a shorter-acting safe and effective κ -receptor antagonist. On the other hand, BU10119 is a single compound combining the pharmacology of buprenorphine/naltrexone it acts as a short κ -receptor antagonist and with no or little μ -receptor agonist activity (resemble the combination buprenorphine/ naltrexone) and the data here show the potential as an antidepressant treatment. However, it is not known if BU10119 could cause activation of JNK which may in turn cause disturbance in fatty acid oxidation in a ventricular cardiac tissue and cause cardiac dysfunction. A lot of work needed to be done to investigate the safety and the efficacy of BU10119 in different variable and multiple stress model such as the Flinders Sensitive Line rat or the chronic unpredictable mild stress model (Overstreet and Wegener, 2013; Monteiro et al., 2015).

7.3 Why are κ -antagonists likely to be antidepressant?

Most of research on depressive disorders has focussed on the possible role of 5-HT and NA neurotransmitter system. Indeed, it has been reported that U50,488 produced decrease in 5-HT during local infusion into the dorsal raphe nucleus, median raphe nucleus, and NAc (Tao and Auerbach, 2002) which may take part in the explaining of the depressive and anxiogenic-like effects in behavioural paradigms produced by stress and κ -receptor agonist. In our FST experiments, buprenorphine/naltrexone combination and BU10119 treatment decreased immobility with a concomitant increase in swimming behaviour, without an effect on climbing behaviour and it has been documented that the antidepressants that target the

serotonergic system increase swimming behaviour, whereas those that target noradrenergic systems increase climbing behaviour, thereby decreasing immobility (Detke et al., 1995), this may indicate that serotonergic pathways are implicated in the opioid-mediated antidepressant effects seen here, as has been suggested by others (Bruchas et al., 2011). On the other hand, there is evidence that other systems may play an important role in the development of depressive disorders. One of these systems is dopaminergic system. It has been reported that disturbance in DA function in NAc lead to anhedonia (Wise, 1982; Wise, 2008). Moreover, it has been reported that 5-HT, NE systems (Pasquier et al., 1977) and endogenous opioid system (Shippenberg and Rea, 1997; Svingos et al., 1999) modulate DA system. Indeed, there is evidence suggests that activation of the κ -receptors, after stress, causes a reduction in dopamine release in different brain regions and that may take part in the pathophysiology of depression (Spanagel et al., 1992; Carlezon et al., 2006; Ebner et al., 2010; Belujon and Grace, 2015). Thus, stress may disturb the balance of different neurotransmitter in brain which may contribute to the development of depressive disorder. On the other hand, the κ -antagonists GNTI, norBNI and ANTI have shown antidepressant-like effects (Newton et al., 2002; Mague et al., 2003; Shirayama et al., 2004; Carr et al., 2009) when measured in FST. Moreover, it has been demonstrated that κ -receptor antagonists such as norBNI, GNTI and the JDTic decrease anxiety-like behaviors in mouse tests, including the NIH and EPM (Van'T and Carlezon, 2013; Hang et al., 2015) and increase the release of dopamine in different brain regions (You et al., 1999; Pliakas et al., 2001; Beardsley et al., 2005) Also, restoring the DA balance, by κ -receptor antagonist, may lead to restoration the balance of NA and 5-HT in the brain, which may explain its antidepressant-like effects.

In conclusion, the systemic co-administration of buprenorphine (1 mg/kg) with naltrexone (1 mg/kg) and BU10119 (1 mg/kg) in adult CD-1 male mice function as short κ -receptor antagonist in the tail withdrawal assay, increased the time spent swimming and reduced immobile behaviour in the

FST, reduced the latency to drink milk in the novel cage in the NIH task and they were able to block SIA, suggesting that these drugs are novel and have potential as antidepressant treatments.

Reference

- Ackroff, K., Rozental, D. & Sclafani, A., 2004. Ethanol-conditioned flavor preferences compared with sugar- and fat-conditioned preferences in rats. *Physiology and Behavior*, 81(4), pp.699–713.
- Adinoff, B., 2004. Neurobiologic processes in drug reward and addiction. *Harvard review of Psychiatry*, 12(6), pp.305–320.
- Agmo, a. & Marroquin, E., 1997. Role of gustatory and postingestive actions of sweeteners in the generation of positive affect as evaluated by place preference conditioning. *Appetite*, 29(3), pp.269–289.
- Alcaraz, C., Milanes, M. V & Vargas, M.L., 1993. Chronic kappa opioid receptor antagonism produces supersensitivity to U-50,488H at the hypothalamo-pituitary-adrenocortical (HPA) axis level. *The Journal of pharmacology and experimental therapeutics*, 266(3), pp.1385–1389.
- Aldrich, J. V, Patkar, K.A. & McLaughlin, J.P., 2009. Zyklophin, a systemically active selective kappa opioid receptor peptide antagonist with short duration of action. *Proceedings of the National Academy of Sciences of the United States of America*, 106(43), pp.18396–18401.
- Almatroudi, A. et al., 2015. Combined administration of buprenorphine and naltrexone produces antidepressant-like effects in mice. *Journal of Psychopharmacology*, 29(7), pp.812–821.
- Al-Sukhni, M., Maruschak, N.A. & McIntyre, R.S., 2015. Vortioxetine : a review of efficacy, safety and tolerability with a focus on cognitive symptoms in major depressive disorder. *Expert Opinion on Drug Safety*, 14(8), pp.1291–1304.
- American Psychiatric Association, 2013. Diagnostic and Statistical Manual of Mental Disorders, 5th Edition (DSM-5). *Diagnostic and Statistical Manual of Mental Disorders 4th edition TR.*, p.280.
- Anderson, I.M., 2000. Selective serotonin reuptake inhibitors versus tricyclic antidepressants: A meta-analysis of efficacy and tolerability. *Journal of Affective Disorders*, 58(1), pp.19–36.
- Anderson, R.I., Lopez, M.F. and Becker, H.C., 2016. Forced swim stress increases ethanol consumption in C57BL/6J mice with a history of chronic intermittent ethanol exposure. *Psychopharmacology*, 233(11), pp.2035-2043.
- Andre, J. et al., 2005. Involvement of cholecystokinergic systems in anxiety-induced hyperalgesia in male rats: behavioral and biochemical studies. *The Journal of Neuroscience*, 25(35), pp.7896–7904.

- Anisman, H. et al., 2008. Serotonin receptor subtype and p11 mRNA expression in stress-relevant brain regions of suicide and control subjects. *Journal of Psychiatry and Neuroscience*, 33(2), pp.131–141.
- Arango, V. et al., 2001. Serotonin 1A receptors, serotonin transporter binding and serotonin transporter mRNA expression in the brainstem of depressed suicide victims. *Neuropsychopharmacology*, 25(6), pp.892–903.
- Arborelius, L. et al., 1999. The role of corticotropin-releasing factor in depression and anxiety disorders. *The Journal of endocrinology*, 160, pp.1–12.
- Armario, A., 2006. The hypothalamic-pituitary-adrenal axis: what can it tell us about stressors? *CNS & Neurological Disorders Drug Targets*, 5(5), pp.485–501.
- Arner, S. & Meyerson, B.A., 1988. Lack of analgesic effect of opioids on neuropathic and idiopathic forms of pain. *Pain*, 33(1), pp.11–23.
- Attard, A., 2012. Antidepressants. *Medicine*, 40(12), pp.681–683.
- Baker, K.G., Halliday, G.M. & Törk, I., 1990. Cytoarchitecture of the human dorsal raphe nucleus. *The Journal of comparative neurology*, 301(2), pp.147–161.
- Baldessarini, R.J., 1989. Current status of antidepressants: Clinical pharmacology and therapy. *Journal of Clinical Psychiatry*, 50(4), pp.117–126.
- Bals-Kubik, R. et al., 1993. Neuroanatomical sites mediating the motivational effects of opioids as mapped by the conditioned place preference paradigm in rats. *The Journal of pharmacology and experimental therapeutics*, 264(1), pp.489–495.
- Baraban, J.M. and Aghajanian, G.K., 1980. Suppression of firing activity of 5-HT neurons in the dorsal raphe by alpha-adrenoceptor antagonists. *Neuropharmacology*, 19(4), pp.355-363.
- Bardo, M.T. & Bevins, R.A., 2000. Conditioned place preference: What does it add to our preclinical understanding of drug reward? *Psychopharmacology*, 153(1), pp.31–43.
- Barnes, N.M. & Sharp, T., 1999. A review of central 5-HT receptors and their function. *Neuropharmacology*, 38(8), pp.1083–1152.
- Basbaum, A.I. et al., 2009. Cellular and molecular mechanisms of pain. *Cell*, 139(2), pp.267–284.

- Beardsley, P.M. et al., 2005. Differential effects of the novel kappa opioid receptor antagonist, JDTC, on reinstatement of cocaine-seeking induced by footshock stressors vs cocaine primes and its antidepressant-like effects in rats. *Psychopharmacology*, 183(1), pp.118–126.
- Béguin, C. & Cohen, B.M., 2009. Medicinal Chemistry of Kappa Opioid Receptor Antagonists. In *Opiate Receptors and Antagonists: from Bench to Clinic*. Edited by Dean RL, Bilsky EJ, Negus SS. *New York: Humana Press*. pp. 99–118.
- Belcheva, M.M. et al., 1998. Opioid modulation of extracellular signal-regulated protein kinase activity is ras-dependent and involves Gbetagamma subunits. *Journal of neurochemistry*, 70(2), pp.635–645.
- Belcheva, M.M. et al., 2005. Mu and kappa opioid receptors activate ERK/MAPK via different protein kinase C isoforms and secondary messengers in astrocytes. *Journal of Biological Chemistry*, 280(30), pp.27662–27669.
- Belmaker, R.H. & Agam, G., 2008. Major depressive disorder. *The New England journal of medicine*, 358(1), pp.55–68.
- Belujon, P. & Grace, A.A., 2015. Regulation of dopamine system responsivity and its adaptive and pathological response to stress. *Proceedings of the Royal Society B: Biological Sciences*, 282(1805), pp.20142516–20142516.
- Belzung, C. & Griebel, G., 2001. Measuring normal and pathological anxiety-like behaviour in mice: A review. *In Behavioural Brain Research*. pp. 141–149.
- Bennett, K.J. & Torrance, G.W., 1996. Measuring health state preferences and utilities: rating scale, time trade-off, and standard gamble techniques. In *Quality of Life and Pharmacoeconomics in Clinical Trials*. pp. 253–265.
- Berger, B. et al., 2006. Presynaptic opioid receptors on noradrenergic and serotonergic neurons in the human as compared to the rat neocortex. *British journal of pharmacology*, 148(6), pp.795–806.
- Berrocchio, E. et al., 2013. Active behaviours produced by antidepressants and opioids in the mouse tail suspension test. *The International Journal of Neuropsychopharmacology*, pp.151–162.
- Berton, O. & Nestler, E.J., 2006. New approaches to antidepressant drug discovery: Beyond monoamines. *Nature Reviews Neuroscience*, 7(2), pp.137–151.

- Bilkei-Gorzo, A. et al., 2008. Control of hormonal stress reactivity by the endogenous opioid system. *Psychoneuroendocrinology*, 33(4), pp.425–436.
- Birch, P.J. et al., 1991. Neuroprotective actions of GR89696, a highly potent and selective kappa-opioid receptor agonist. *British journal of pharmacology*, 103(3), pp.1819–1823
- Birmes, P. et al., 2003. Serotonin syndrome: a brief review. *Canadian Medical Association Journal*, 168(11), pp.1439–1442.
- Blazer, D.G. & Hybels, C.F., 2005. Origins of depression in later life. *Psychological Medicine*, 35(9), pp.1241–1252.
- Blier, P., Chaput, Y. & de Montigny, C., 1988. Long-term 5-HT reuptake blockade, but not monoamine oxidase inhibition, decreases the function of terminal 5-HT autoreceptors: an electrophysiological study in the rat brain. *Naunyn-Schmiedeberg's Archives of Pharmacology*, 337(3), pp.246–254.
- Bockaert, J. et al., 1987. Piperazine derivatives including the putative anxiolytic drugs, buspirone and ipsapirone, are agonists at 5-HT_{1A} receptors negatively coupled with adenylate cyclase in hippocampal neurons. *Naunyn-Schmiedeberg's Archives of Pharmacology*, 335(5), pp.588–592.
- Bodkin, J.A. et al., 1995. Buprenorphine treatment of refractory depression. *Journal of Clinical Psychopharmacology*, 15(1), pp.49–57.
- Bodnar, R.J., 2014. Endogenous opiates and behavior: 2013. *Peptides*, 62, pp.67-136.
- Bodnoff, S.R. et al., 1988. The effects of chronic antidepressant treatment in an animal model of anxiety. *Psychopharmacology (Berl)*, 95(3), pp.298–302.
- Bodnoff, S.R. et al., 1989. A comparison of the effects of diazepam versus several typical and atypical anti-depressant drugs in an animal model of anxiety. *Psychopharmacology*, 97(2), pp.277–279.
- Bohn, L.M. & Raehal, K.M., 2006. Opioid receptor signaling: relevance for gastrointestinal therapy. *Current Opinion in Pharmacology*, 6(6), pp.559–563.
- Booij, L., Van der Does, a J.W. & Riedel, W.J., 2003. Monoamine depletion in psychiatric and healthy populations: review. *Molecular psychiatry*, 8(12), pp.951–973.

- Borsini, F. & Meli, A., 1988. Is the forced swimming test a suitable model for revealing antidepressant activity? *Psychopharmacology*, 94(2), pp.147–160.
- Bouza, C. et al., 2004. Efficacy and safety of naltrexone and acamprosate in the treatment of alcohol dependence: A systematic review. *Addiction*, 99(7), pp.811–828.
- Bowen, D.M. et al., 1989. Circumscribed changes of the cerebral cortex in neuropsychiatric disorders of later life. *Proceedings of the National Academy of Sciences of the United States of America*, 86(23), pp.9504–9508.
- Bremner, J.D. et al., 2000. Hippocampal volume reduction in major depression. *The American Journal of Psychiatry*, 157(1), pp.115–118.
- Broadbear, J.H. et al., 2000. Methocinnamox is a potent, long-lasting, and selective antagonist of morphine-mediated antinociception in the mouse: comparison with clocinnamox, beta-funaltrexamine, and beta-chlornaltrexamine. *The Journal of Pharmacology and Experimental Therapeutics*, 294(3), pp.933–940.
- Broadhead, W.E. et al., 1990. Depression, disability days, and days lost from work in a prospective epidemiologic survey. *JAMA*, 264(19), pp.2524–2528.
- Broquet, K.E., 1999. Status of treatment of depression. *Southern medical journal*, 92(9), pp.846-856.
- Brown, S.M. et al., 2011. Buprenorphine metabolites, buprenorphine-3-glucuronide and norbuprenorphine-3-glucuronide, are biologically active. *Anesthesiology*, 115(6), pp.1251–1260.
- Bruchas, M.R. & Chavkin, C., 2010. Kinase cascades and ligand-directed signaling at the kappa opioid receptor. *Psychopharmacology*, 209(2), pp.137–147.
- Bruchas, M.R. et al., 2006. Kappa opioid receptor activation of p38 MAPK is GRK3- and arrestin-dependent in neurons and astrocytes. *Journal of Biological Chemistry*, 281(26), pp.18081–18089.
- Bruchas, M.R. et al., 2007. Long-acting kappa opioid antagonists disrupt receptor signaling and produce noncompetitive effects by activating c-Jun N-terminal kinase. *Journal of Biological Chemistry*, 282(41), pp.29803–29811.
- Bruchas, M.R. et al., 2007a. Stress-induced p38 mitogen-activated protein kinase activation mediates kappa-opioid-dependent dysphoria. *Journal of Neuroscience*, 27(43), pp.11614–11623.

- Bruchas, M.R. et al., 2009. CRF1-R activation of the dynorphin/kappa opioid system in the mouse basolateral amygdala mediates anxiety-like behavior. *PLoS ONE*, 4(12), p.e8528.
- Bruchas, M.R. et al., 2011. Selective p38 α MAPK deletion in serotonergic neurons produces stress resilience in models of depression and addiction. *Neuron*, 71(3), pp.498–511.
- Bruchas, M.R., Land, B.B. & Chavkin, C., 2010. The dynorphin/kappa opioid system as a modulator of stress-induced and pro-addictive behaviors. *Brain Research*, 1314, pp.44–55.
- Bruchas, M.R., Xu, M. & Chavkin, C., 2008. Repeated swim stress induces kappa opioid-mediated activation of extracellular signal-regulated kinase 1/2. *Neuroreport*, 19(14), pp.1417–1422.
- Buda, J.J. et al., 2015. A Double-Blind, Placebo-Controlled Trial to Evaluate the Safety, Tolerability, and Pharmacokinetics of Single, Escalating Oral Doses of JD1c. *Neuropsychopharmacology*, 40(9), pp.2059–2065.
- Buller, K.M., Wixey, J.A. & Reinebrant, H.E., 2012. Disruption of the serotonergic system after neonatal hypoxia-ischemia in a rodent model. *Neurology Research International*, 2012.
- Butler, R.K. & Finn, D.P., 2009. Stress-induced analgesia. *Progress in Neurobiology*, 88(3), pp.184–202.
- Buynitsky, T. & Mostofsky, D.I., 2009. Restraint stress in biobehavioral research: Recent developments. *Neuroscience and Biobehavioral Reviews*, 33(7), pp.1089–1098.
- Callahan, E.J. et al., 1980. The treatment of heroin addiction: naltrexone alone and with behavior therapy. *The International Journal of the Addictions*, 15(6), pp.795–807.
- Campbell, A.D. and McBride, W.J., 1995. Serotonin-3 receptor and ethanol-stimulated dopamine release in the nucleus accumbens. *Pharmacology, Biochemistry and Behavior*, 51(4), pp.835–842.
- Capasso, A., Petrella, C. & Milano, W., 2009. Pharmacological profile of SSRIs and SNRIs in the treatment of eating disorders. *Current Clinical Pharmacology*, 4(1), pp.78–83.
- Carey, A.N. et al., 2007. Reinstatement of cocaine place-conditioning prevented by the peptide kappa-opioid receptor antagonist arodyn. *European Journal of Pharmacology*, 569(1-2), pp.84–89.

- Carey, A.N. et al., 2009. Endogenous kappa opioid activation mediates stress-induced deficits in learning and memory. *The Journal of neuroscience*, 29(13), pp.4293–300.
- Carlezon, W.A. et al., 2006. Depressive-like effects of the kappa-opioid receptor agonist salvinorin A on behavior and neurochemistry in rats. *The Journal of Pharmacology and Experimental Therapeutics*, 316(1), pp.440–447.
- Carmen, B. et al., 2004. Efficacy and safety of naltrexone and acamprosate in the treatment of alcohol dependence: A systematic review. *Addiction*, 99(7), pp.811–828.
- Carr, G. V et al., 2009. Antidepressant-Like Effects of κ -Opioid Receptor Antagonists in Wistar Kyoto Rats. *Neuropsychopharmacology*, 35(10), pp.752–763.
- Carr, G. V. & Lucki, I., 2010. Comparison of the kappa-opioid receptor antagonist DIPPA in tests of anxiety-like behavior between wistar kyoto and sprague dawley rats. *Psychopharmacology*, 209(2), pp.295–302.
- Carroll, F.I. et al., 2006. N-substituted 4beta-methyl-5-(3-hydroxyphenyl)-7alpha-amidomorphans are potent, selective kappa opioid receptor antagonists. *Journal of medicinal chemistry*, 49(5), pp.1781–1791.
- Carroll, I. et al., 2004. Pharmacological properties of JDTC: a novel kappa-opioid receptor antagonist. *European Journal of Pharmacology*, 501(1–3), pp.111–119.
- Carroll, M.E. et al., 1990. Fluoxetine reduces intravenous cocaine self-administration in rats. *Pharmacol Biochem Behav*, 35(1), pp.237–244.
- Casal-dominguez, J.J. et al., 2013. In vivo and in vitro characterization of naltrindole-derived ligands at the kappa-opioid receptor. *Journal of Psychopharmacology*, 27(2), pp.192–202.
- Casal-Dominguez, J.J. et al., 2014. Characterization of BU09059: A novel potent selective κ -receptor antagonist. *ACS Chemical Neuroscience*, 5(3), pp.177–184.
- Casati, A., Sedefov, R. and Pfeiffer-Gerschel, T., 2012. Misuse of medicines in the European union: A systematic review of the literature. *European Addiction Research*, 18(5), pp.228–245.
- Caspi, A. et al., 2003. Influence of life stress on depression: moderation by a polymorphism in the 5-HTT gene. *Science (New York, N. Y.)*, 301(5631), pp.386–389.

- Castren, E., Voikar, V. & Rantamaki, T., 2007. Role of neurotrophic factors in depression. *Curr Opin Pharmacol*, 7(1), pp.18–21.
- Cervo, L. and Samanin, R., 1988. Repeated treatment with imipramine and amitriptyline reduced the immobility of rats in the swimming test by enhancing dopamine mechanisms in the nucleus accumbens. *Journal of pharmacy and pharmacology*, 40(2), pp.155-156.
- Cesana, R. et al., 1993. Mesulergine antagonism towards the fluoxetine anti-immobility effect in the forced swimming test in mice. *The Journal of Pharmacy and Pharmacology*, 45(5), pp.473–475.
- Chan, K. et al., 1995. The effect of the irreversible mu-opioid receptor antagonist clocinnamox on morphine potency, receptor binding and receptor mRNA. *European Journal of Pharmacology*, 287(2), pp.135–143.
- Chang, L. & Karin, M., 2001. Mammalian MAP kinase signalling cascades. *Nature*, 410(6824), pp.37–40.
- Charney, D.S. and Manji, H.K., 2004. Life stress, genes, and depression: multiple pathways lead to increased risk and new opportunities for intervention. *Science's STKE: signal transduction knowledge environment*, 2004(225), p.re5.
- Chartoff, E.H. et al., 2009. Desipramine reduces stress-activated dynorphin expression and CREB phosphorylation in NAc tissue. *Molecular Pharmacology*, 75(3), pp.704–712.
- Chauvignac, C., Miller, C.N., Srivastava, S.K., Lewis, J.W., Husbands, S.M. and Traynor, J.R., 2005. Major effect of pyrrolic N-benylation in norbinaltorphimine, the selective kappa-opioid receptor antagonist. *Journal of medicinal chemistry*, 48(5), pp.1676-1679.
- Chavkin, C., James, I.F. & Goldstein, A., 1982. Dynorphin is a specific endogenous ligand of the kappa opioid receptor. *Science*, 215(4531), pp.413–415.
- Chen, Y. et al., 1993. Molecular cloning of a rat kappa opioid receptor reveals sequence similarities to the mu and delta opioid receptors. *The Biochemical Journal*, 295 (Pt 3(1 993), pp.625–628.
- Chen, Y. et al., 2005. Behavioral and biochemical studies of total furocoumarins from seeds of *Psoralea corylifolia* in the forced swimming test in mice. *Journal of Ethnopharmacology*, 96(3), pp.451–459.
- Cherny, N.I. et al., 1994. Opioid responsiveness of cancer pain syndromes caused by neuropathic or nociceptive mechanisms: a combined analysis of controlled, single-dose studies. *Neurology*, 44, pp.857–861.

- Childs, E. & de Wit, H., 2009. Amphetamine-Induced Place Preference in Humans. *Biological Psychiatry*, 65(10), pp.900–904.
- Claghorn, J.L. et al., 1996. Fluvoxamine maleate in the treatment of depression: a single-center, double-blind, placebo-controlled comparison with imipramine in outpatients. *Journal of Clinical Psychopharmacology*, 16, pp.113–120.
- Clark, C.R. et al., 1988. Highly selective kappa opioid analgesics. Synthesis and structure-activity relationships of novel N-[(2-aminocyclohexyl)aryl]acetamide and N-[(2-aminocyclohexyl)aryloxy]acetamide derivatives. *Journal of medicinal chemistry*, 31(4), pp.831–836.
- Clark, R.A. et al., 2012. A comparison of InVivoStat with other statistical software packages for analysis of data generated from animal experiments. *Journal of Psychopharmacology*, 26(8), pp.1136–1142.
- Clayton, C.C., Xu, M. & Chavkin, C., 2009. Tyrosine phosphorylation of Kir3 following kappa-opioid receptor activation of p38 MAPK causes heterologous desensitization. *The Journal of biological chemistry*, 284(46), pp.31872–31881.
- Clement, H.W., Gemsa, D. & Wesemann, W., 1992. The effect of adrenergic drugs on serotonin metabolism in the nucleus raphe dorsalis of the rat, studied by in vivo voltammetry. *European Journal of Pharmacology*, 217(1), pp.43–48.
- Collu, M. et al., 1997. Fluoxetine-induced conditioned place preference: a preliminary study. *Synapse*, 25(3), pp.309–311.
- Comer, S.D. et al., 1992. Clocinnamox: a novel, systemically-active, irreversible opioid antagonist. *The Journal of Pharmacology and Experimental Therapeutics*, 262(3), pp.1051–1056.
- Comer, S.D. et al., 2006. Injectable, sustained-release naltrexone for the treatment of opioid dependence: a randomized, placebo-controlled trial. *Archives of General Psychiatry*, 63(2), pp.210–218
- Conrad, L.C.A. and Pfaff, D.W., 1976. Autoradiographic tracing of nucleus accumbens efferents in the rat. *Brain research*, 113(3), pp.589-596.
- Corbett, A.D. et al., 2006. 75 years of opioid research: the exciting but vain quest for the Holy Grail. *British Journal of Pharmacology*, 147 Suppl , pp.S153–162.
- Cordery, S.F. et al., 2014. A non-rewarding, non-aversive buprenorphine/naltrexone combination attenuates drug-primed

reinstatement to cocaine and morphine in rats in a conditioned place preference paradigm. *Addiction Biology*, 19(4), pp.575–586.

Cowan, a., Lewis, J.W. & MacFarlane, I.R., 1977. Agonist and Antagonist Properties of Buprenorphine, a New Antinociceptive Agent. *British Journal of Pharmacology*, 60(4), pp.537–545.

Crain, S.M. & Shen, K.F., 1990. Opioids can evoke direct receptor-mediated excitatory effects on sensory neurons. *Trends in pharmacological sciences*, 11(February), pp.77–81

Crawley, J. & Goodwin, F.K., 1980. Preliminary report of a simple animal behavior model for the anxiolytic effects of benzodiazepines. *Pharmacology Biochemistry and Behavior*, 13(2), pp.167–170.

Crawley, J.N., 1981. Neuropharmacologic specificity of a simple animal model for the behavioral actions of benzodiazepines. *Pharmacology, Biochemistry and Behavior*, 15(5), pp.695–699.

Crowley, N.A. & Kash, T.L., 2015. Kappa opioid receptor signaling in the brain: Circuitry and implications for treatment. *Progress in neuro-psychopharmacology & biological psychiatry*, 62, pp.51–60.

Cryan, J.F. & Holmes, A., 2005. The ascent of mouse: advances in modelling human depression and anxiety. *Nat Rev Drug Discov*, 4(9), pp.775–790.

Cryan, J.F. & Lucki, I., 2000. Antidepressant-like behavioral effects mediated by 5-Hydroxytryptamine(2C) receptors. *The Journal of Pharmacology and Experimental Therapeutics*, 295(3), pp.1120–1126.

Cryan, J.F. & Slattery, D. A, 2007. Animal models of mood disorders: Recent developments. *Current Opinion in Psychiatry*, 20(1), pp.1–7.

Cryan, J.F. & Sweeney, F.F., 2011. The age of anxiety: Role of animal models of anxiolytic action in drug discovery. *British Journal of Pharmacology*, 164(4), pp.1129–1161.

Cryan, J.F., Markou, a & Lucki, I., 2002. Assessing antidepressant activity in rodents: recent developments and future needs. *Trends in Pharmacological Sciences*, 23(5), pp.238–245.

Cryan, J.F., Page, M.E. & Lucki, I., 2005a. Differential behavioral effects of the antidepressants reboxetine, fluoxetine, and moclobemide in a modified forced swim test following chronic treatment. *Psychopharmacology*, 182(3), pp.335–344.

Cryan, J.F., Valentino, R.J. & Lucki, I., 2005b. Assessing substrates underlying the behavioral effects of antidepressants using the modified

rat forced swimming test. *Neuroscience and Biobehavioral Reviews*, 29(4-5), pp.547–569.

Cueva, J.P. et al., 2015. C7 β - methyl analogues of the orvinols: The discovery of kappa opioid antagonists with nociceptin/orphanin FQ peptide (NOP) receptor partial agonism and low, or zero, efficacy at Mu opioid receptors. *Journal of Medicinal Chemistry*, 58(10), pp.4242–4249.

Cunningham, C.L., Gremel, C.M. & Groblewski, P.A., 2006. Drug-induced conditioned place preference and aversion in mice. *Nature Protocols*, 1(4), pp.1662–1670.

Dahan, A. et al., 2006. Buprenorphine induces ceiling in respiratory depression but not in analgesia. *British Journal of Anaesthesia*, 96(5), pp.627–632.

Dailly, E. et al., 2004. Dopamine, depression and antidepressants. *Fundamental and Clinical Pharmacology*, 18(6), pp.601–607.

Dale, E., Bang-Andersen, B. & Sa´nchez, C., 2015. Emerging mechanisms and treatments for depression beyond SSRIs and SNRIs. *Biochemical Pharmacology*, 95, pp.81–97.

Da-Rocha, M.A., Puech, A.J. & Thiébot, M.H., 1997. Influence of anxiolytic drugs on the effects of specific serotonin reuptake inhibitors in the forced swimming test in mice. *Journal of Psychopharmacology (Oxford, England)*, 11(3), pp.211–218.

David, V. & Cazala, P., 1994. Differentiation of intracranial morphine self-administration behavior among five brain regions in mice. *Pharmacology Biochemistry and Behavior*, 48(3), pp.625–633.

Davidson, C. & Stamford, J.A., 1995. The effect of paroxetine on 5-HT efflux in the rat dorsal raphe nucleus is potentiated by both 5-HT_{1A} and 5-HT_{1B} D receptor antagonists. *Neuroscience Letters*, 188(1), pp.41–44.

Davis, R.J., 2000. Signal Transduction by the JNK Group of MAP Kinases. *Cell*, 103(2), pp.239–252.

De Deurwaerdère, P., Stinus, L. and Spampinato, U., 1998. Opposite change of in vivo dopamine release in the rat nucleus accumbens and striatum that follows electrical stimulation of dorsal raphe nucleus: role of 5-HT₃ receptors. *The Journal of Neuroscience*, 18(16), pp.6528–6538.

Dean, A.J. et al., 2006. Does naltrexone treatment lead to depression? Findings from a randomized controlled trial in subjects with opioid dependence. *Journal of Psychiatry and Neuroscience*, 31(1), pp.38–45.

- Deardorff, W.J. & Grossberg, G.T., 2014. A review of the clinical efficacy, safety and tolerability of the antidepressants vilazodone, levomilnacipran and vortioxetine. *Expert Opinion on Pharmacotherapy*, 15(17), pp.2525–2542.
- DeGraaf, J.S., vanRiezen. H., Berendsen. H.H.G., vanDelft, A.M.L., 1985. A set of behavioural tests predicting antidepressant activity. *Drug Development Research*, (5), pp.291-301.
- Delay, J., Laine, B. and Buisson, J.F., 1952. The action of isonicotinyl-hydrazide used in the treatment of depressive states. *Annales médico-psychologiques*, 110(2,5), pp. 689.
- Dennis, T. et al., 1987. Presynaptic alpha-2 adrenoceptors play a major role in the effects of idazoxan on cortical noradrenaline release (as measured by in vivo dialysis) in the rat. *Journal of Pharmacology and Experimental Therapeutics*, 241(2), pp.642-649.
- DePaoli, A.M. et al., 1994. Distribution of kappa opioid receptor mRNA in adult mouse brain: an in situ hybridization histochemistry study. *Molecular and Cellular Neurosciences*, 5(4), pp.327–335.
- Descarries, L. et al., 1982. The serotonin neurons in nucleus raphe dorsalis of adult rat: a light and electron microscope radioautographic study. *The Journal of comparative neurology*, 207(3), pp.239–254.
- Detke, M.J., Johnson, J. & Lucki, I., 1997. Acute and chronic antidepressant drug treatment in the rat forced swimming test model of depression. *Experimental and clinical psychopharmacology*, 5(2), pp.107–112.
- Detke, M.J., Rickels, M. & Lucki, I., 1995. Active behaviors in the rat forced swimming test differentially produced by serotonergic and noradrenergic antidepressants. *Psychopharmacology*, 121(1), pp.66–72.
- Di Chiara, G. & Bassareo, V., 2007. Reward system and addiction: what dopamine does and doesn't do. *Current Opinion in Pharmacology*, 7(1), pp.69–76.
- Dilts, R.P. & Kalivas, P.W., 1989. Autoradiographic localization of mu-opioid and neurotensin receptors within the mesolimbic dopamine system. *Brain Research*, 488(1-2), pp.311–327.
- Doucet, E. et al., 1995. In situ hybridization evidence for the synthesis of 5-HT(1B) receptor in serotonergic neurons of anterior raphe nuclei in the rat brain. *Synapse*, 19(1), pp.18–28.
- Dulawa, S.C. & Hen, R., 2005. Recent advances in animal models of chronic antidepressant effects: The novelty-induced hypophagia test. *Neuroscience and Biobehavioral Reviews*, 29(4–5), pp.771–783.

- Dulawa, S.C. et al., 2004. Effects of chronic fluoxetine in animal models of anxiety and depression. *Neuropsychopharmacology*, 29(7), pp.1321–1330.
- Dum, J., Blasig, J. & Herz, A., 1981. Buprenorphine: Demonstration of physical dependence liability. *European Journal of Pharmacology*, 70(3), pp.293–300.
- Duman, R.S. & Monteggia, L.M., 2006. A Neurotrophic Model for Stress-Related Mood Disorders. *Biological Psychiatry*, 59(12), pp.1116–1127.
- Duman, R.S., Nakagawa, S. & Malberg, J.E., 2001. Regulation of adult neurogenesis by antidepressant treatment. *Neuropsychopharmacology*, 25(6), pp.836–844.
- Ebner, S.R. et al., 2010. Depressive-like effects of the kappa opioid receptor agonist salvinorin A are associated with decreased phasic dopamine release in the nucleus accumbens. *Psychopharmacology*, 209(2), pp.241–252.
- Ehrich, E. et al., 2015. Evaluation of Opioid Modulation in Major Depressive Disorder. *Neuropsychopharmacology*, 40(6), pp. 1448–1455.
- Eisenach, J.C., Carpenter, R. & Curry, R., 2003. Analgesia from a peripherally active kappa-opioid receptor agonist in patients with chronic pancreatitis. *Pain*, 101(1-2), pp.89–95.
- Emrich, H.M, Vogt, P & Herz, A 1982. Possible antidepressive effects of opioids: Action of buprenorphine. *Annals New York Academy of Sciences*, pp. 398: 108–112.
- Endoh, T. et al., 1992. Nor-binaltorphimine: a potent and selective kappa-opioid receptor antagonist with long-lasting activity in vivo. *Archives Internationales de Pharmacodynamie et de Thérapie*, 316, pp.30–42.
- Evrard, A. et al., 1999. 5-HT(1A) and 5-HT(1B) receptors control the firing of serotonergic neurons in the dorsal raphe nucleus of the mouse: Studies in 5-HT(1B) knock-out mice. *European Journal of Neuroscience*, 11(11), pp.3823–3831.
- Falcon, E. et al., 2015. Effects of buprenorphine on behavioral tests for antidepressant and anxiolytic drugs in mice. *Psychopharmacology*, 232(5), pp.907–915.
- Falcon, E. et al., 2016. Antidepressant-Like Effects of Buprenorphine are Mediated by Kappa Opioid Receptors. *Neuropsychopharmacology*, pp.1–8.

- Fava, M. and Davidson, K.G., 1996. Definition and epidemiology of treatment-resistant depression. *Psychiatric Clinics of North America*, 19(2), pp.179–198.
- Fava, M. et al., 2000. Anxiety disorders in Major Depression. *Comprehensive Psychiatry*, 41(2), pp.97–102.
- Fava, M. et al., 2008. Difference in treatment outcome in outpatients with anxious versus nonanxious depression: A STAR*D report. *American Journal of Psychiatry*, 165(3), pp.342–351.
- Fava, M. et al., 2016. Opioid Modulation With Buprenorphine/Samidorphan as Adjunctive Treatment for Inadequate Response to Antidepressants: A Randomized Double-Blind Placebo-Controlled Trial. *American Journal of Psychiatry*, 173(5), pp.499-508.
- Ferland, C.L. et al., 2014. Facilitation of the HPA axis to a novel acute stress following chronic stress exposure modulates histone acetylation and the ERK/MAPK pathway in the dentate gyrus of male rats. *Endocrinology*, 155(8), pp.2942–2952.
- Fernando, A. B.P. & Robbins, T.W., 2011. Animal models of neuropsychiatric disorders. *Annual Review of Clinical Psychology*, 7(1), pp.39–61.
- Fichna, J. et al., 2007. Antidepressant-like effect of endomorphin-1 and endomorphin-2 in mice. *Neuropsychopharmacology*, 32(4), pp.813–821.
- Fields, H.L., 2011. The Doctor's Dilemma: Opiate Analgesics and Chronic Pain. *Neuron*, 69(4), pp.591–594.
- File, S.E., 2001. Factors controlling measures of anxiety and responses to novelty in the mouse. *In Behavioural Brain Research*. pp. 151–157.
- Filho, C.B. et al., 2013. Kappa-opioid receptors mediate the antidepressant-like activity of hesperidin in the mouse forced swimming test. *European Journal of Pharmacology*, 698(1-3), pp.286–291.
- Filibek, U., Castellano, C. & Oliverio, A., 1981. Differential Effects of Opiate Agonists-Antagonists on Morphine-Induced Hyperexcitability and Analgesia in Mice. *Psychopharmacology*, 73, pp.134–136.
- Filliol, D. et al., 2000. Mice deficient for delta- and mu-opioid receptors exhibit opposing alterations of emotional responses. *Nature genetics*, 25(2), pp.195–200.
- Finberg, J.P.M. & Gillman, K., 2011. Selective inhibitors of monoamine oxidase type B and the “cheese effect.” *International Review of Neurobiology*, 100, pp.169–190.

- Fisone, G. et al., 2007. Signaling in the basal ganglia: Postsynaptic and presynaptic mechanisms. *Physiology and Behavior*, 92(1–2), pp.8–14.
- Fitton, a, Faulds, D. & Goa, K.L., 1992. Moclobemide. A review of its pharmacological properties and therapeutic use in depressive illness. *Drugs*, 43(4), pp.561–596.
- Fjalland, B. and Christensen, J.D., 1990. κ -Opioid Receptor Agonists Differentially Affect the Release of Neurohypophysial Hormones. *Pharmacology & toxicology*, 66(3), pp.176-178.
- Foils, A.R., Lui, P. & Romeo, R.D., 2011. The transformation of hormonal stress responses throughout puberty and adolescence. *Journal of Endocrinology*, 210(3), pp.391–398.
- Fuchs, E. & Flügge, G., 2006. Experimental animal models for the simulation of depression and anxiety. *Dialogues in Clinical Neuroscience*, 8(3), pp.323–333.
- García-Sevilla, J.A. et al., 1999. Up-regulation of immunolabeled $\alpha(2A)$ -adrenoceptors, G(i) coupling proteins, and regulatory receptor kinases in the prefrontal cortex of depressed suicides. *Journal of Neurochemistry*, 72(1), pp.282–291.
- Garzón, M. & Pickel, V.M., 2001. Plasmalemmal mu-opioid receptor distribution mainly in nondopaminergic neurons in the rat ventral tegmental area. *Synapse*, 41(4), pp.311–328.
- Gerra, G., Fantoma, a. & Zaimovic, a, 2006. Naltrexone and buprenorphine combination in the treatment of opioid dependence. *Journal of Psychopharmacology*, 20(6), pp.806–814.
- Gesty-Palmer, D. et al., 2006. Distinct β -arrestin and G protein dependent pathways for parathyroid hormone receptor stimulated ERK1/2 activation. *Journal of Biological Chemistry*, 281, pp.10856–10864.
- Ghirmai, S. et al., 2008. Synthesis and biological evaluation of alpha- and beta-6-amido derivatives of 17-cyclopropylmethyl-3, 14beta-dihydroxy-4, 5alpha-epoxymorphinan: potential alcohol-cessation agents. *Journal of Medicinal Chemistry*, 51(6), pp.1913–1924.
- Giordano, A.L., Nock. B. and Cicero. T.J., 1990. Antagonist-induced upregulation of the putative epsilon opioid receptor in rat brain: comparison with kappa, mu and delta opioid receptors. *The Journal of Pharmacology and Experimental Therapeutics*, 255: 536–540.
- Gobert, A., Rivet, J.M., Cistarelli, L. and Millan, M.J., 1997. Potentiation of the fluoxetine-induced increase in dialysate levels of serotonin (5-HT) in the frontal cortex of freely moving rats by combined blockade of 5-HT_{1A}

- and 5-HT_{1B} receptors with WAY 100,635 and GR 127,935. *Journal of neurochemistry*, 68(3), pp.1159-1163.
- Gold, P.W. and Chrousos, G.P., 2002. Organization of the stress system and its dysregulation in melancholic and atypical depression: high vs low CRH/NE states. *Molecular Psychiatry*, 7, pp.254–275.
- Gong, S. et al., 2015. Dynamics and correlation of serum cortisol and corticosterone under different physiological or stressful conditions in mice. *PLoS ONE*, 10(2), p.e0117503.
- Goodwin, F.K. and Bunney, W.E., 1971, November. Depressions following reserpine: a reevaluation. *Seminars in psychiatry*. 3(4),pp. 435-448.
- Grady, M.M. and Stahl, S.M., 2012. Practical guide for prescribing MAOIs: debunking myths and removing barriers. *CNS Spectrums*, 17(01), pp.2–10.
- Griebel, G. et al., 2000. Differences in anxiety-related behaviours and in sensitivity to diazepam in inbred and outbred strains of mice. *Psychopharmacology*, 148(2), pp.164–170.
- Grignaschi, G. et al., 1998. Citalopram-induced hypophagia is enhanced by blockade of 5-HT_{1A} receptors: role of 5-HT_{2C} receptors. *British Journal of Pharmacology*, 124(8), pp.1781–1787.
- Grissom, N. et al., 2007. The physical context of previous stress exposure modifies hypothalamic-pituitary-adrenal responses to a subsequent homotypic stress. *Hormones and Behavior*, 51(1), pp.95–103.
- Grudt, T.J. & Williams, J.T., 1995. Opioid receptors and the regulation of ion conductances. *Rev Neurosci*, 6(3), pp.279–286.
- Guimaraes, F.S. et al., 1993. Hippocampal 5-HT receptors and consolidation of stressful memories. *Behavioural Brain Research*, 58(1-2), pp.133–139.
- Gutstein, H.B. & Akil, H., 2001. Opioid Analgesics. In: Goodman LS, Hardman JG, Limbird LE, Gilman AG (eds) *Goodman & Gilman's the Pharmacological Basis of Therapeutics*. McGraw- Hill, New York, pp. 569–619.
- Haenisch, B. et al., 2009. Knockout of the norepinephrine transporter and pharmacologically diverse antidepressants prevent behavioral and brain neurotrophin alterations in two chronic stress models of depression. *Journal of Neurochemistry*, 111(2), pp.403–416.
- Hall, A.J. et al., 2008. Patterns of Abuse Among Unintentional Pharmaceutical Overdose Fatalities. *Jama*, 300(22), pp.2613–2620.

- Hammen, C., 2005. Stress and depression. *Annual Review of Clinical Psychology*, 1(1), pp.293–319.
- Han, J. et al., 1994. A MAP kinase targeted by endotoxin and hyperosmolarity in mammalian cells. *Science*, 265(5173), pp.808–811.
- Hang, A. et al., 2015. The role of the dynorphin/kappa opioid receptor system in anxiety. *Acta Pharmacologica Sinica*, 36(7), pp.783–790.
- Hascoët, M. & Bourin, M., 2009. The mouse light-dark box test. *Neuromethods*, 42, pp.197–223.
- Hascoët, M., Bourin, M. & Nic Dhonnchadha, B.A., 2001. The mouse light-dark paradigm: A review. *Progress in Neuro-Psychopharmacology and Biological Psychiatry*, 25(1), pp.141–166.
- Hayes, B.D., Klein-Schwartz, W. and Doyon, S., 2008. Toxicity of buprenorphine overdoses in children. *Pediatrics*, 121(4), pp.e782–e786.
- Heisler, L.K. et al., 1998. Elevated anxiety and antidepressant-like responses in serotonin 5-HT_{1A} receptor mutant mice. *Proceedings of the National Academy of Sciences of the United States of America*, 95(25), pp.15049–15054.
- Henry, D.J. et al., 1995. Kappa-opioid receptors couple to inwardly rectifying potassium channels when coexpressed by *Xenopus* oocytes. *Molecular Pharmacology*, 47(3), pp.551–557.
- Hensler, J.G., Kovachich, G.B. & Frazer, A., 1991. A quantitative autoradiographic study of serotonin_{1A} receptor regulation. Effect of 5,7-dihydroxytryptamine and antidepressant treatments. *Neuropsychopharmacology*, 4(2), pp.131–144.
- Hjelmstad, G.O. & Fields, H.L., 2001. Kappa opioid receptor inhibition of glutamatergic transmission in the nucleus accumbens shell. *Journal of neurophysiology*, 85(3), pp.1153–1158.
- Hjelmstad, G.O. & Fields, H.L., 2003. Kappa opioid receptor activation in the nucleus accumbens inhibits glutamate and GABA release through different mechanisms. *Journal of neurophysiology*, 89(5), pp.2389–2395.
- Holma, K.M. et al., 2010. Incidence and predictors of suicide attempts in DSM-IV major depressive disorder: A five-year prospective study. *American Journal of Psychiatry*, 167(7), pp.801–808.
- Holmes, A., 2001. Targeted gene mutation approaches to the study of anxiety-like behavior in mice. *Neuroscience & Biobehavioral Reviews*, 25(3), pp.261–273.

- Holmes, P. V., 2003. Rodent models of depression: reexamining validity without anthropomorphic inference. *Critical Reviews in Neurobiology*, 15(2), pp.143–174.
- Holsboer, F., 2001. Stress, hypercortisolism and corticosteroid receptors in depression: Implications for therapy. *Journal of Affective Disorders*, 62(1–2), pp.77–91.
- Horan, P. et al., 1992. Extremely long-lasting antagonistic actions of norbinaltorphimine (nor-BNI) in the mouse tail-flick test. *The Journal of Pharmacology and Experimental Therapeutics*, 260(3), pp.1237–1243.
- Horan, P.J. & Porreca, F., 1993. Lack of cross-tolerance between U69, 593 and bremazocine suggests kappa-opioid receptor multiplicity in mice. *European Journal of Pharmacology*, 239, pp.93–98.
- Huang, P. et al., 2016. Two short-acting kappa opioid receptor antagonists (zyklophin and LY2444296) exhibited different behavioral effects from the long-acting antagonist norbinaltorphimine in mouse anxiety tests. *Neuroscience Letters*, 615, pp.15–20.
- Huang, Y.Y. et al., 1999. Relationship of psychopathology to the human serotonin(1B) genotype and receptor binding kinetics in postmortem brain tissue. *Neuropsychopharmacology*, 21(2), pp.238–246.
- Hunter, J.C. et al., 1990. CI-977, a novel and selective agonist for the kappa-opioid receptor. *British Journal of Pharmacology*, 101(1), pp.183–189.
- Hunter, R.G. and McEwen, B.S., 2013. Stress and anxiety across the lifespan: structural plasticity and epigenetic regulation. *Epigenomics*, 5(2), pp.177–194.
- Hurley, R.W. et al., 1999. Interaction between medullary and spinal delta1 and delta2 opioid receptors in the production of antinociception in the rat. *The Journal of Pharmacology and Experimental Therapeutics*, 289(2), pp.993–999.
- Huston, J.P. et al., 2013. What's conditioned in conditioned place preference? *Trends in Pharmacological Sciences*, 34(3), pp.162–166.
- Hyman, S.E., Malenka, R.C. & Nestler, E.J., 2006. Neural mechanisms of addiction: the role of reward-related learning and memory. *Annual Review of Neuroscience*, 29, pp.565–598.
- Iadarola, M.J. et al., 1988. Enhancement of dynorphin gene expression in spinal cord following experimental inflammation: stimulus specificity, behavioral parameters and opioid receptor binding. *Pain*, 35(3), pp.313–326.

- Ide, S. et al., 2004. Buprenorphine antinociception is abolished, but naloxone-sensitive reward is retained, in μ -opioid receptor knockout mice. *Neuropsychopharmacology*, 29(9), pp.1656–1663.
- Ide, S. et al., 2010. Reduced emotional and corticosterone responses to stress in mu-opioid receptor knockout mice. *Neuropharmacology*, 58(1), pp.241–247.
- Ikemoto, S., 2010. Brain reward circuitry beyond the mesolimbic dopamine system: A neurobiological theory. *Neuroscience and Biobehavioral Reviews*, 35(2), pp.129–150.
- Imaizumi, M., Miyazaki, S. & Onodera, K., 1994. Effects of xanthine derivatives in a light/dark test in mice and the contribution of adenosine receptors. *Methods and findings in experimental and clinical pharmacology*, 16(9), pp.639-644.
- Itoh, Y. et al., 1990. In vivo measurement of noradrenaline and 3,4-dihydroxyphenylethyleneglycol in the rat hypothalamus by microdialysis: effects of various drugs affecting noradrenaline metabolism. *The Journal of Pharmacology and Experimental Therapeutics*, 255(3), pp.1090–1097.
- Jaber, M. et al., 1996. Dopamine receptors and brain function. *Neuropharmacology*, 35(11), pp.1503–19.
- Jackson, H.C., Griffin, I.J. & Nutt, D.J., 1993. Buprenorphine-cocaine interactions in mice: effect on locomotor activity and hole-dipping behaviour. *Journal of Pharmacy and Pharmacology*, 45(7), pp.636–640.
- Jackson, K.J. et al., 2010. Effect of the selective kappa-opioid receptor antagonist JDTC on nicotine antinociception, reward, and withdrawal in the mouse. *Psychopharmacology*, 209(2), pp.285–294.
- Jacobs, B.L. & Azmitia, E.C., 1992. Structure and function of the brain serotonin system. *Physiological reviews*, 72(1), pp.165–229.
- Jennings, E.M. et al., 2014. Stress-induced hyperalgesia. *Progress in Neurobiology*, 121, pp.1–18.
- Johnson, D.A. et al., 2007. Glucocorticoid Receptor Antagonists Hasten and Augment Neurochemical Responses to a Selective Serotonin Reuptake Inhibitor Antidepressant. *Biological Psychiatry*, 62(11), pp.1228–1235.
- Johnson, D.A. et al., 2009. Glucocorticoid receptor antagonism augments fluoxetine-induced downregulation of the 5-HT transporter. *Neuropsychopharmacology*, 34(2), pp.399–409.

- Johnson, G.L. & Lapadat, R., 2002. Mitogen-activated protein kinase pathways mediated by ERK, JNK, and p38 protein kinases. *Science*, 298(5600), pp.1911–1912.
- Johnson, S.M., Kinney, M.E. & Wiegel, L.M., 2008. Inhibitory and excitatory effects of micro-, delta-, and kappa-opioid receptor activation on breathing in awake turtles, *Trachemys scripta*. *American journal of physiology. Regulatory, integrative and comparative physiology*, 295(5), pp.R1599-1612.
- Johnson, S.W. & North, R.A., 1992. Opioids excite dopamine neurons by hyperpolarization of local interneurons. *The Journal of Neuroscience*, 12(2), pp.483–488.
- Jones, R.M. & Portoghese, P.S., 2000. 5'-Guanidinonaltrindole, a highly selective and potent kappa-opioid receptor antagonist. *European journal of pharmacology*, 396(1), pp.49–52.
- Jones, R.M. and Paterlini, M.G., 1998. kappa-Opioid receptors: recent advances and implications for drug design. *Current opinion in drug discovery & development*, 1(2), pp.175-182.
- Jordan, B.A. & Devi, L.A., 1999. G-protein-coupled receptor heterodimerization modulates receptor function. *Nature*, 399(6737), pp.697–700.
- Judge, S.J. & Gartside, S.E., 2006. Firing of 5-HT neurones in the dorsal and median raphe nucleus in vitro shows differential α 1-adrenoceptor and 5-HT 1A receptor modulation. *Neurochemistry international*, 48(2), pp.100-107.
- Kajiwara, M. et al., 1986. Agonist and antagonist actions of buprenorphine on three types of opioid receptor in isolated preparations. *The Japanese Journal of Pharmacology*, 40(1), pp.95–101.
- Kakko, J. et al., 2007. A stepped care strategy using buprenorphine and methadone versus conventional methadone maintenance in heroin dependence: A randomized controlled trial. *American Journal of Psychiatry*, 164(5), pp.797–803.
- Kanazawa, I., 1994. Short review on monoamine oxidase and its inhibitors. *European Neurology*, 34 Suppl 3, pp.36–39.
- Karp, J.F. et al., 2014. Safety, tolerability, and clinical effect of low-dose buprenorphine for treatment-resistant depression in midlife and older adults. *The Journal of Clinical Psychiatry*, 75(8), pp.e785–793.
- Kastin, A.J. et al., 1978. Enkephalin and other peptides reduce passiveness. *Pharmacology Biochemistry and Behavior*, 9(4), pp.515–519.

- Katon, W., 1987. The epidemiology of depression in medical care. *International Journal of Psychiatry in Medicine*, 17(1), pp.93–112.
- Katz, R.J., 1981. Animal models and human depressive disorders. *Neuroscience and Biobehavioral Reviews*, 5(2), pp.231–246.
- Kavaliers, M. & Innes, D., 1987. Stress-induced opioid analgesia and activity in deer mice: sex and population differences. *Brain Research*, 425(1), pp.49–56.
- Keller, M.B., 2001. Long-term treatment of recurrent and chronic depression. *Journal of Clinical Psychiatry*, 62(SUPPL.,24), pp.3–5.
- Kennett, G.A., Dickinson, S.L. & Curzon, G., 1985. Central serotonergic responses and behavioural adaptation to repeated immobilisation: The effect of the corticosterone synthesis inhibitor metyrapone. *European Journal of Pharmacology*, 119(3), pp.143–152.
- Kerr, G.W., McGuffie, a C. & Wilkie, S., 2001. Tricyclic antidepressant overdose: a review. *Emergency Medicine Journal*, 18(4), pp.236–241.
- Kessler, R.C. et al., 1996. Comorbidity of DSM-III-R major depressive disorder in the general population: results from the US National Comorbidity Survey. *The British Journal of Psychiatry. Supplement*, (30), pp.17–30.
- Khawam, E.A., Laurencic, G. & Malone, D.A., 2006. Side effects of antidepressants: An overview. *Cleveland Clinic Journal of Medicine*, 73(4), pp.351–361.
- Kieffer, B.L. & Gavériaux-Ruff, C., 2002. Exploring the opioid system by gene knockout. *Progress in Neurobiology*, 66(5), pp.285–306.
- Kieffer, B.L., 1995. Recent advances in molecular recognition and signal transduction of active peptides: Receptors for opioid peptides. *Cellular and Molecular Neurobiology*, 15(6), pp.615–635.
- Kim, E. et al., 2006. Mu- and kappa-opioids induce the differentiation of embryonic stem cells to neural progenitors. *The Journal of biological chemistry*, 281(44), pp.33749–33760.
- Kim, J.G. et al., 2013. Basal blood corticosterone level is correlated with susceptibility to chronic restraint stress in mice. *Neuroscience Letters*, 555, pp.137–142.
- Kitchen, I. et al., 1997. Quantitative autoradiographic mapping of μ -, δ - and κ -opioid receptors in knockout mice lacking the μ -opioid receptor gene. *Brain Research*, 778(1), pp.73–88.

- Klerman, G.L and Cole, J.O, 1965. Clinical pharmacology of imipramine and related antidepressant compounds, *Pharmacological Reviews*, 17(2), pp.101–41.
- Klimek, V. et al., 1997. Reduced levels of norepinephrine transporters in the locus coeruleus in major depression. *The Journal of neuroscience*, 17(21), pp.8451–8458.
- Knobelman, D. a, Hen, R. & Lucki, I., 2001. Genetic regulation of extracellular serotonin by 5-hydroxytryptamine(1A) and 5-hydroxytryptamine(1B) autoreceptors in different brain regions of the mouse. *The Journal of pharmacology and experimental therapeutics*, 298(3), pp.1083–1091.
- Knoll, A.T. et al., 2007. Anxiolytic-like effects of kappa-opioid receptor antagonists in models of unlearned and learned fear in rats. *The Journal of Pharmacology and Experimental Therapeutics*, 323(3), pp.838–845.
- Knoll, A.T. et al., 2011. Kappa opioid receptor signaling in the basolateral amygdala regulates conditioned fear and anxiety in rats. *Biological Psychiatry*, 70(5), pp.425–433.
- Kögel, B. et al., 2005. Interaction of mu-opioid receptor agonists and antagonists with the analgesic effect of buprenorphine in mice. *European Journal of pain (London, England)*, 9(5), pp.599–611.
- Kolesnikov, Y.A. et al., 1996. Peripheral morphine analgesia: synergy with central sites and a target of morphine tolerance. *The Journal of Pharmacology and Experimental Therapeutics*, 279(2), pp.502–506.
- Koneru A; Satyanarayana S; Rizman S, 2009. Endogenous Opioids : Their Physiological Role and Receptors. *Global Journal of Pharmacology*, 3(3), pp.149–153.
- Koneru, A., Satyanarayana, S. & Rizman. S., 2009. Endogenous Opioids : Their Physiological Role and Receptors. *Global Journal of Pharmacology*, 3(3), pp.149–153.
- Konkoy, C.S. and Childers, S.R., 1993. Relationship between kappa 1 opioid receptor binding and inhibition of adenylyl cyclase in guinea pig brain membranes. *Biochemical Pharmacology* , 45(1), pp.207–216.
- Krishnan, V. & Nestler, E.J., 2008. The molecular neurobiology of depression. *Nature*, 455(7215), pp.894–902.
- Kuehner, C., 2003. Gender differences in unipolar depression: an update of epidemiological findings and possible explanations. *Acta Psychiatrica Scandinavica*, 108(3), pp.163–174.

- Kumar, V., Bhat, Z.A. & Kumar, D., 2013. Animal models of anxiety: A comprehensive review. *Journal of Pharmacological and Toxicological Methods*, 68(2), pp.175–183.
- Kurrikoff, K. et al., 2008. Stress-induced analgesia in mice: Evidence for interaction between endocannabinoids and cholecystokinin. *European Journal of Neuroscience*, 27(8), pp.2147–2155.
- Kyriakis, J.M. & Avruch, J., 2001. Mammalian mitogen-activated protein kinase signal transduction pathways activated by stress and inflammation. *Physiological reviews*, 81(2), pp.807–869.
- Lahti, R.A. et al., 1985. [3H]U-69593 a highly selective ligand for the opioid κ receptor. *European Journal of Pharmacology*, 109(2), pp.281–284.
- Lahti, R.A., VonVoigtlander, P.F. & Barsuhn, C., 1982. Properties of a selective kappa agonist, U-50,488H. *Life Sciences*, 31(20–21), pp.2257–2260.
- Lakshmi Reddy, P. et al., 1992. CSF amine metabolites in depression. *Biological Psychiatry*, 31(2), pp.112–118.
- Land, B.B. et al., 2008. The Dysphoric Component of Stress Is Encoded by Activation of the Dynorphin κ -Opioid System. *The Journal of neuroscience : the official journal of the Society for Neuroscience*, 28(2), pp.407–414.
- Land, B.B. et al., 2009. Activation of the kappa opioid receptor in the dorsal raphe nucleus mediates the aversive effects of stress and reinstates drug seeking. *Proceedings of the National Academy of Sciences of the United States of America*, 106(45), pp.19168–19173.
- Laorden, M.L. and Milanés, M.V., 2000. Effects of U-50,488H and U-50,488H withdrawal on catecholaminergic neurons of the rat hypothalamus. *Life Sciences*, 66(9), pp.803–815.
- Larson, D.L., Jones, R.M., Hjorth, S.A., Schwartz, T.W. and Portoghese, P.S., 2000. Binding of norbinaltorphimine (norBNI) congeners to wild-type and mutant mu and kappa opioid receptors: molecular recognition loci for the pharmacophore and address components of kappa antagonists. *Journal of medicinal chemistry*, 43(8), pp.1573-1576.
- Lawrence, D.M. and Bidlack, J.M., 1993. The kappa opioid receptor expressed on the mouse R1.1 thymoma cell line is coupled to adenylyl cyclase through a pertussis toxin-sensitive guanine nucleotide-binding regulatory protein. *Journal of Pharmacology and Experimental Therapeutics*, 266(3), pp.1678–1683.

- Le Bars, D., Gozariu, M. & Cadden, S.W., 2001. Animal models of nociception. *Pharmacological Reviews*, 53(4), pp.597–652.
- Lelong-Boulouard, V. et al., 2006. Interactions of buprenorphine and dipotassium clorazepate on anxiety and memory functions in the mouse. *Drug and Alcohol Dependence*, 85(2), pp.103–113.
- Lépine, J.P. and Briley, M., 2011. The increasing burden of depression. *Neuropsychiatric Disease and Treatment*, 7(SUPPL.), pp.3–7.
- Lewis, S.R. et al., 2005. Inbred mouse strain survey of sucrose intake. *Physiology and Behavior*, 85(5), pp.546–556.
- Li, S. et al., 2012. Effects of acute restraint stress on different components of memory as assessed by object-recognition and object-location tasks in mice. *Behavioural Brain Research*, 227(1), pp.199–207.
- Limberger, N., Bonanno, G., Späth, L. and Starke, K., 1986. Autoreceptors and α 2-adrenoceptors at the serotonergic axons of rabbit brain cortex. *Naunyn-Schmiedeberg's archives of pharmacology*, 332(4), pp.324-331.
- Lin, S. et al., 2006. Distribution of prodynorphin mRNA and its interaction with the NPY system in the mouse brain. *Neuropeptides*, 40(2), pp.115–123.
- Lister, R.G., 1987. The use of a plus-maze to measure anxiety in the mouse. *Psychopharmacology*, 92(2), pp.180–185.
- Lizasoain, I., Leza, J.C. & Lorenzo, P., 1991. Buprenorphine: Bell-shaped dose-response curve for its antagonist effects. *General Pharmacology*, 22(2), pp.297–300.
- Lledo, P.-M., Alonso, M. & Grubb, M.S., 2006. Adult neurogenesis and functional plasticity in neuronal circuits. *Nature reviews. Neuroscience*, 7(3), pp.179–193.
- Lloyd, M.H. & Wolfensohn, S.E., 1999. Practical use of distress scoring systems in the application of humane endpoints. *Humane Endpoints in Animal Experiments for Biomedical Research*, pp.48–53.
- Lopez-Figueroa, A.L. et al., 2004. Serotonin 5-HT1A, 5-HT1B, and 5-HT2A receptor mRNA expression in subjects with major depression, bipolar disorder, and schizophrenia. *Biological Psychiatry*, 55(3), pp.225–233.
- López-Muñoz, F. & Alamo, C., 2009. Monoaminergic neurotransmission: the history of the discovery of antidepressants from 1950s until today. *Current Pharmaceutical Design*, 15(14), pp.1563–1586.

- Lowe, S.L. et al., 2014. Safety, tolerability, and pharmacokinetic evaluation of single- and multiple-ascending doses of a novel kappa opioid receptor antagonist LY2456302 and drug interaction with ethanol in healthy subjects. *Journal of Clinical Pharmacology*, 54(9), pp.968–978.
- Lucki, I., 1997. The forced swimming test as a model for core and component behavioral effects of antidepressant drugs. *Behavioural Pharmacology*, 8(6-7), pp.523–532.
- Lucki, I., Kreider, M.S. & Simansky, K.J., 1988. Reduction of feeding behavior by the serotonin uptake inhibitor sertraline. *Psychopharmacology*, 96(3), pp.289–295.
- Lüscher, C. & Malenka, R.C., 2011. Drug-Evoked Synaptic Plasticity in Addiction: From Molecular Changes to Circuit Remodeling. *Neuron*, 69(4), pp.650–663.
- Lutfy, K. & Cowan, A., 2004. Buprenorphine: a unique drug with complex pharmacology. *Current Neuropharmacology*, 2(4), pp.395–402.
- Lutfy, K. et al., 2003. Buprenorphine-induced antinociception is mediated by mu-opioid receptors and compromised by concomitant activation of opioid receptor-like receptors. *The Journal of Neuroscience*, 23(32), pp.10331–10337.
- Luttinger, D., 1985. Determination of antinociceptive efficacy of drugs in mice using different water temperatures in a tail-immersion test. *Journal of Pharmacological Methods*, 13(4), pp.351–357.
- Mague, S.D. et al., 2003. Antidepressant-like effects of kappa-opioid receptor antagonists in the forced swim test in rats. *The Journal of pharmacology and experimental therapeutics*, 305(1), pp.323–330.
- Maisonneuve, I.M., Archer, S. & Glick, S.D., 1994. U50,488, a κ opioid receptor agonist, attenuates cocaine-induced increases in extracellular dopamine in the nucleus accumbens of rats. *Neuroscience Letters*, 181(1-2), pp.57–60.
- Maj, J. et al., 1996. Antidepressant drugs given repeatedly change the binding of the dopamine D2 receptor agonist, [3H]N-0437, to dopamine D2 receptors in the rat brain. *European Journal of Pharmacology*, 304(1–3), pp.49–54.
- Maj, J. et al., 1998. Effect of antidepressant drugs administered repeatedly on the dopamine D3 receptors in the rat brain. *European journal of pharmacology*, 351(1), pp.31–37.

- Maj, J., Klimek, V. & Nowak, G., 1985. Antidepressant drugs given repeatedly increase binding to α 1-adrenoceptors in the rat cortex. *European Journal of Pharmacology*, 119(1–2), pp.113–116.
- Malberg, J.E. et al., 2000. Chronic antidepressant treatment increases neurogenesis in adult rat hippocampus. *The Journal of Neuroscience*, 20(24), pp.9104–9110.
- Malcolm, R. et al., 1987. Naltrexone and dysphoria: a double-blind placebo controlled trial. *Biological Psychiatry*, 22(6), pp.710–716.
- Malison, R.T. et al., 1998. Reduced brain serotonin transporter availability in major depression as measured by [123I]-2 beta-carbomethoxy-3 beta-(4-iodophenyl)tropane and single photon emission computed tomography. *Biological Psychiatry*, 44(11), pp.1090–1098.
- Mann, J.J. et al., 2000. A serotonin transporter gene promoter polymorphism (5-HTTLPR) and prefrontal cortical binding in major depression and suicide. *Archives of general psychiatry*, 57(8), pp.729–738.
- Mansour, A. et al., 1994. Kappa 1 receptor mRNA distribution in the rat CNS: comparison to kappa receptor binding and prodynorphin mRNA. *Molecular and Cellular Neuroscience*, 5(2), pp.124–144.
- Mansour, A. et al., 1995. Opioid-receptor mRNA expression in the rat CNS: anatomical and functional implications. *Trends in Neurosciences*, 18(1), pp.22–29.
- Mansour, A. et al., 1995. Opioid-receptor mRNA expression in the rat CNS: anatomical and functional implications. *Trends in Neurosciences*, 18(1), pp.22–29.
- Mansson, E., Bare, L. & Yang, D., 1994. Isolation of a human kappa opioid receptor cDNA from placenta. *Biochemical & Biophysical Research Communications*, 202(3), pp.1431–1437.
- Marquez, P. et al., 2007. The mu opioid receptor is involved in buprenorphine-induced locomotor stimulation and conditioned place preference. *Neuropharmacology*, 52(6), pp.1336–1341.
- Marshall, R., 1983. The pharmacology of mianserin-an update. *British Journal of Clinical Pharmacology*, 15(2 S), p.263S–268S.
- Martin, W.R., 1979. History and development of mixed opioid agonists, partial agonists and antagonists. *British Journal of Clinical Pharmacology*, 7(S3), p.273S–279S.
- MartínezFernández, E. et al., 2002. The history of opiates. *International Congress Series*, 1242(0), pp.75–77.

- Matthes, H.W. et al., 1996. Loss of morphine-induced analgesia, reward effect and withdrawal symptoms in mice lacking the mu-opioid-receptor gene. *Nature*, 383(6603), pp.819–823.
- Maura, G. & Raiteri, M., 1986. Cholinergic terminals in rat hippocampus possess 5-HT_{1B} receptors mediating inhibition of acetylcholine release. *European Journal of Pharmacology*, 129(3), pp.333–337.
- Mauskopf, J.A. et al., 2009. Nonresponse, partial response, and failure to achieve remission: humanistic and cost burden in major depressive disorder. *Depression and Anxiety*, 26(1), pp.83–97.
- Mayorga, A.J. et al., 2001. Antidepressant-Like Behavioral Effects in 5-Hydroxytryptamine_{1A} and 5-Hydroxytryptamine_{1B} Receptor Mutant Mice. *The Journal Of Pharmacology And Experimental Therapeutics*, 298(3), pp.1101–1107.
- Mazure, C.M., 1998. Life stressors as risk factors in depression. *Clinical Psychology: Science and Practice*, 5(3), pp.291–313.
- McClellan, M.N. et al., 2007. Cross-talk and decision making in MAP kinase pathways. *Nature genetics*, 39(3), pp.409–414.
- McDermott, C.M. & Schrader, L. a, 2011. Activation of κ opioid receptors increases intrinsic excitability of dentate gyrus granule cells. *The Journal of physiology*, 589(Pt 14), pp.3517–3532.
- McEwen, B.S., 1999. Stress and Hippocampal Plasticity. *Annual Review of Neuroscience*, 22(1), pp.105–122.
- McLaughlin, J.P. et al., 2006a. Social defeat stress-induced behavioral responses are mediated by the endogenous kappa opioid system. *Neuropsychopharmacology*, 31(6), pp.1241–1248.
- McLaughlin, J.P. et al., 2006b. Prior activation of kappa opioid receptors by U50,488 mimics repeated forced swim stress to potentiate cocaine place preference conditioning. *Neuropsychopharmacology*, 31(4), pp.787–794.
- McLaughlin, J.P., Marton-Popovici, M. & Chavkin, C., 2003. Kappa opioid receptor antagonism and prodynorphin gene disruption block stress-induced behavioral responses. *The Journal of neuroscience*, 23(13), pp.5674–5683.
- McLennan, G.P. et al., 2008. Kappa opioids promote the proliferation of astrocytes via Gbetagamma and beta-arrestin 2-dependent MAPK-mediated pathways. *Journal of Neurochemistry*, 107(6), pp.1753–1765.

- Mcnally, G.P. & Akil, H., 2002. Opioid peptides and their receptors: Overview and function in pain modulation. *Neuropsychopharmacology: The Fifth Generation of Progress*, pp.35–46.
- Melief, E.J. et al., 2011. Duration of action of a broad range of selective κ -opioid receptor antagonists is positively correlated with c-Jun N-terminal kinase-1 activation. *Molecular Pharmacology*, 80(5), pp.920–9.
- Mello, N.K. & Mendelson, J.H., 1985. Behavioral pharmacology of buprenorphine. *Drug and Alcohol Dependence*, 14(3-4), pp.283–303.
- Mello, N.K. et al., 1988. Progressive ratio performance maintained by buprenorphine, heroin and methadone in Macaque monkeys. *Drug and Alcohol Dependence*, 21(2), pp.81–97.
- Mendelson, J.H. et al., 1978. Effects of naltrexone on mood and neuroendocrine function in normal adult males. *Psychoneuroendocrinology*, 3(3–4), pp.231–236.
- Meng, F. et al., 1993. Cloning and pharmacological characterization of a rat kappa opioid receptor. *Proceedings of the National Academy of Sciences*, 90(21), pp.9954–9958.
- Mental Health Policy Group: The London School of Economics & Mental Health Policy Group: The Centre for Economic Performance's, 2006. *The Depression Report, A New Deal for Depression and Anxiety Disorders*, Available at: <http://eprints.lse.ac.uk/818/>.
- Meredith, G.E., Pennartz, C.M. and Groenewegen, H.J., 1993. The cellular framework for chemical signalling in the nucleus accumbens. *Progress in brain research*, 99, pp.3-24.
- Millan, M.J. et al., 1988. Inflammation of the hind limb as a model of unilateral, localized pain: influence on multiple opioid systems in the spinal cord of the rat. *Pain*, 35(3), pp.299–312.
- Millan, M.J., 1989. Kappa-opioid receptor-mediated antinociception in the rat. I. Comparative actions of mu- and kappa-opioids against noxious thermal, pressure and electrical stimuli. *The Journal of pharmacology and experimental therapeutics*, 251(1), pp.334–341.
- Miller, D.B., 1988. Restraint-induced analgesia in the CD-1 mouse: interactions with morphine and time of day. *Brain Research*, 473(2), pp.327–335.
- Minami, M. et al., 1993. Cloning and expression of a cDNA for the rat kappa-opioid receptor. *FEBS letters*, 329(3), pp.291–295.

- Missale, C. et al., 1998. Dopamine receptors: from structure to function. *Physiological reviews*, 78(1), pp.189–225.
- Mitchell, P.J. & Redfern, P.H., 2005. Animal models of depressive illness: the importance of chronic drug treatment. *Current Pharmaceutical Design*, 11(2), pp.171–203.
- Mitra, R., Adamec, R. & Sapolsky, R., 2009. Resilience against predator stress and dendritic morphology of amygdala neurons. *Behavioural Brain Research*, 205(2), pp.535–543.
- Moffett, M.C. et al., 2007. Maternal separation alters drug intake patterns in adulthood in rats. *Biochemical Pharmacology*, 73(3), pp.321–330.
- Mollereau, C. et al., 1994. ORL1, a novel member of the opioid receptor family. Cloning, functional expression and localization. *FEBS letters*, 341(1), pp.33–38.
- Mombereau, C. et al., 2010. Differential effects of acute and repeated citalopram in mouse models of anxiety and depression. *The international journal of neuropsychopharmacology*, 13(3), pp.321–334.
- Moncrieff, J. & Kirsch, I., 2005. Efficacy of antidepressants in adults. *British Medical Journal*, 331(7509), pp.155–157.
- Monteiro, S. et al., 2015. An efficient chronic unpredictable stress protocol to induce stress-related responses in C57BL/6 mice. *Frontiers in Psychiatry*, 6, p.6
- Morgane, P.J., Galler, J.R. and Mokler, D.J., 2005. A review of systems and networks of the limbic forebrain/limbic midbrain. *Progress in Neurobiology*, 75(2), pp.143–160.
- Mozhui, K. et al., 2010. Strain differences in stress responsivity are associated with divergent amygdala gene expression and glutamate-mediated neuronal excitability. *The Journal of Neuroscience*, 30(15), pp.5357–5367
- Mucha, R.F., Millan, M.J. & Herz, A., 1985. Aversive properties of naloxone in non-dependent (naive) rats may involve blockade of central beta-endorphin. *Psychopharmacology*, 86(3), pp.281–285.
- Munro, T.A. et al., 2013. Selective κ Opioid Antagonists nor-BNI, GNTI and JDTic Have Low Affinities for Non-Opioid Receptors and Transporters. *PLoS ONE*, 8(8), p.e70701.
- Musacchio, J.M., 1975. Enzymes involved in the biosynthesis and degradation of catecholamines. In *Biochemistry of Biogenic Amines* (pp. 1-35). Springer US.

- Muscat, R., Papp, M. & Willner, P., 1992. Antidepressant-like effects of dopamine agonists in an animal model of depression. *Biol Psychiatry*, 31(9), pp.937–946.
- Mysels, D.J. et al., 2011. The association between naltrexone treatment and symptoms of depression in opioid-dependent patients. *The American Journal of Drug and Alcohol Abuse*, 37(1), pp.22–26
- Narita, M. et al., 2006. Chronic pain induces anxiety with concomitant changes in opioidergic function in the amygdala. *Neuropsychopharmacology*, 31(4), pp.739–750.
- Negus, S.S. et al., 2002. Kappa opioid antagonist effects of the novel kappa antagonist 5'-guanidinonaltrindole (GNTI) in an assay of schedule-controlled behavior in rhesus monkeys. *Psychopharmacology*, 163(3–4), pp.412–419.
- Nelson, N., 1998. The Family of Na⁺ / Cl⁻ Neurotransmitter Transporters. *J Neurochem*, 71(5), pp.1785–1803.
- Nestler, E.J. & Carlezon, W.A., 2006. The Mesolimbic Dopamine Reward Circuit in Depression. *Biological Psychiatry*, 59(12), pp.1151–1159.
- Nestler, E.J. & Hyman, S.E., 2010. Animal models of neuropsychiatric disorders. *Nature Neuroscience*, 13(10), pp.1161–1169.
- Nestler, E.J. et al., 2002. Neurobiology of depression. *Neuron*, 34(1), pp.13–25.
- Neugebauer, V. et al., 2004. The amygdala and persistent pain. *Neuroscientist*, 10(3), pp.221–234.
- Neumaier, J.F., Root, D.C. & Hamblin, M.W., 1996. Chronic fluoxetine reduces serotonin transporter mRNA and 5-HT(1B) mRNA in a sequential manner in the rat dorsal raphe nucleus. *Neuropsychopharmacology*, 15(5), pp.515–522.
- Neve, K. a, Seamans, J.K. & Trantham-Davidson, H., 2004. Dopamine receptor signaling. *Journal of receptor and signal transduction research*, 24(3), pp.165–205.
- Newton, S.S. et al., 2002. Inhibition of cAMP response element-binding protein or dynorphin in the nucleus accumbens produces an antidepressant-like effect. *The Journal of Neuroscience*, 22(24), pp.10883–10890.
- Nezafati, M.H., Vojdanparast, M. & Nezafati, P., 2015. Antidepressants and cardiovascular adverse events: A narrative review. *ARYA Atherosclerosis*, 11(5), pp.295–304.

- Nieoullon, A. & Coquerel, A., 2003. Dopamine: a key regulator to adapt action, emotion, motivation and cognition. *Current Opinion in Neurology*, 16 Suppl 2, pp.S3–9.
- Nishi, M. et al., 1993. cDNA cloning and pharmacological characterization of an opioid receptor with high affinities for kappa-subtype-selective ligands. *FEBS letters*, 330(1), pp.77–80.
- Nishi, M. et al., 1994. Structure and chromosomal mapping of genes for the mouse kappa-opioid receptor and an opioid receptor homologue (MOR-C). *Biochem Biophys Res Commun*, 205(2), pp.1353–1357.
- O'Connor, J.J. & Kruk, Z.L., 1994. Effects of 21 days treatment with fluoxetine on stimulated endogenous 5-hydroxytryptamine overflow in the rat dorsal raphe and suprachiasmatic nucleus studies using fast cyclic voltammetry in vitro. *Brain Research*, 640(1–2), pp.328–335.
- Olmstead, M.C. & Franklin, K.B., 1997. The development of a conditioned place preference to morphine: effects of microinjections into various CNS sites. *Behavioral Neuroscience*, 111(6), pp.1324–1334.
- Oomen, C.A. et al., 2007. Brief treatment with the glucocorticoid receptor antagonist mifepristone normalizes the reduction in neurogenesis after chronic stress. *European Journal of Neuroscience*, 26(12), pp.3395–3401.
- Overstreet, D.H. & Wegener, G., 2013. The flinders sensitive line rat model of depression--25 years and still producing. *Pharmacological Reviews*, 65(1), pp.143–155.
- Padovan, C.M. & Guimaraes, F.S., 2000. Restraint-induced hypoactivity in an elevated plus-maze. *Brazilian Journal of Medical and Biological Research*, 33(1), pp.79–83.
- Pan, Z.Z., 1998. mu-Opposing actions of the kappa-opioid receptor. *Trends in pharmacological sciences*, 19(3), pp.94–98.
- Pan, Z.Z., 2003. Kappa-opioid receptor-mediated enhancement of the hyperpolarization-activated current (I_h) through mobilization of intracellular calcium in rat nucleus raphe magnus. *The Journal of physiology*, 548(Pt 3), pp.765–775.
- Pande, A.C. et al., 1996. Analgesic efficacy of enadoline versus placebo or morphine in postsurgical pain. *Clinical Neuropharmacology*, 19(5), pp. 451–456.
- Pandya, M. et al., 2012. Where in the brain is depression? *Current Psychiatry Reports*, 14(6), pp.634–642.

- Parker, L.A. & Rennie, M., 1992. Naltrexone-induced aversions: Assessment by place conditioning, taste reactivity, and taste avoidance paradigms. *Pharmacology Biochemistry and Behavior*, 41(3), pp.559–565.
- Parks, C.L. et al., 1998. Increased anxiety of mice lacking the serotonin1A receptor. *Proceedings of the National Academy of Sciences of the United States of America*, 95(18), pp.10734–10739.
- Parsons, L.H. and Justice, J.B., 1993. Serotonin and dopamine sensitization in the nucleus accumbens, ventral tegmental area, and dorsal raphe nucleus following repeated cocaine administration. *Journal of Neurochemistry*, 61, pp.1611–1619.
- Pasquier, D.A. et al., 1977. Dorsal raphe, substantia nigra and locus coeruleus: Interconnections with each other and the neostriatum. *Brain Research Bulletin*, 2(5), pp.323–339.
- Pasternak, A. 2011. The Opiate Receptors, Pasternak G (ed) Vol. 23, 2nd edn.
- Paxinos, G. & Franklin, K.B.J., 2001. The mouse brain in stereotaxic coordinates, *Academic press*, 2nd edition .
- Peckys, D. & Landwehrmeyer, G.B., 1999. Expression of MU, KAPPA, and delta opioid receptor messenger RNA in the human CNS: A 33P in situ hybridization study. *Neuroscience*, 88(4), pp.1093–1135.
- Pellow, S. et al., 1985. Validation of open : closed arm entries in an elevated plus-maze as a measure of anxiety in the rat. *Journal of Neuroscience Methods*, 14(3), pp.149–167.
- Pert, C.B. & Snyder, S.H., 1973a. Properties of opiate-receptor binding in rat brain. *Proceedings of the National Academy of Sciences of the United States of America*, 70(8), pp.2243–2247.
- Pert, C.B. & Snyder, S.H., 1973b. Opiate receptor: demonstration in nervous tissue. *Science (New York, N.Y.)*, 179(77), pp.1011–1014.
- Peters, G.R. et al., 1987. Diuretic actions in man of a selective kappa opioid agonist: U-62,066E. *Journal of Pharmacology and Experimental Therapeutics*, 240(1), pp.128–131.
- Petit-Demouliere, B., Chenu, F. & Bourin, M., 2005. Forced swimming test in mice: A review of antidepressant activity. *Psychopharmacology*, 177(3), pp.245–255.
- Pettinati, H.M., O'Brien, C.P. & Dundon, W.D., 2013. Current status of co-occurring mood and substance use disorders: a new therapeutic target. *The American Journal of Psychiatry*, 170(1), pp.23–30.

- Pfeiffer, A. et al., 1986. Psychotomimesis mediated by kappa opiate receptors. *Science*, 233, pp.774–776.
- Phillipson, O.T., 1979. Afferent projections to the ventral tegmental area of Tsai and interfascicular nucleus: a horseradish peroxidase study in the rat. *Journal of Comparative Neurology*, 187(1), pp.117-143.
- Piñeyro, G. & Blier, P., 1999. Autoregulation of serotonin neurons: role in antidepressant drug action. *Pharmacological reviews*, 51(3), pp.533–591.
- Pitchot, W., Scantamburlo, G. & Ansseau, M., 2011. [Tricyclic antidepressants and monoamine oxidase inhibitors - do they still have a role in the treatment of depression?]. *Revue Medicale De Liege* , 66(3), pp.144–152.
- Pliakas, a M. et al., 2001. Altered responsiveness to cocaine and increased immobility in the forced swim test associated with elevated cAMP response element-binding protein expression in nucleus accumbens. *The Journal of Neuroscience*, 21(18), pp.7397–7403.
- Pliakas, a M. et al., 2001. Altered responsiveness to cocaine and increased immobility in the forced swim test associated with elevated cAMP response element-binding protein expression in nucleus accumbens. *The Journal of neuroscience: the official journal of the Society for Neuroscience*, 21(18), pp.7397–7403.
- Poleszak, E. et al., 2006. Immobility stress induces depression-like behavior in the forced swim test in mice: effect of magnesium and imipramine. *Pharmacological Reports: PR*, 58, pp.746–752.
- Polter, A.M. et al., 2014. Poststress block of kappa opioid receptors rescues long-term potentiation of inhibitory synapses and prevents reinstatement of cocaine seeking. *Biological Psychiatry*, 76(10), pp.785–793.
- Porsolt, R.D., 2000. Animal models of depression: utility for transgenic research. *Reviews in the Neurosciences*, 11(1), pp.53–58.
- Porsolt, R.D., Le Pichon, M. & Jalfre, M., 1977. Depression: a new animal model sensitive to antidepressant treatments. *Nature*, 266(5604), pp.730–732.
- Portoghese, P.S., Garzon-Aburbeh, A., Nagase, H., Lin, C.E. and Takemori, A.E., 1991. Role of the spacer in conferring kappa opioid receptor selectivity to bivalent ligands related to norbinaltorphimine. *Journal of medicinal chemistry*, 34(4), pp.1292-1296.
- Portoghese, P.S., Lin, C.E., Farouz-Grant, F. and Takemori, A.E., 1994. Structure-Activity Relationship of N17'-Substituted Norbinaltorphimine

- Congeners. Role of the N17'Basic Group in the Interaction with a Putative Address Subsite on the. kappa. Opioid Receptor. *Journal of medicinal chemistry*, 37(10), pp.1495-1500.
- Portoghese, P.S., Nagase, H. and Takemori, A.E., 1988. Stereochemical studies on medicinal agents. 31. Only one pharmacophore is required for the. kappa. opioid antagonist selectivity of norbinaltorphimine. *Journal of medicinal chemistry*, 31(7), pp.1344-1347.
- Post, R. et al., 1980. Lack of effect of carbamazepine on gamma-aminobutyric acid in cerebrospinal fluid. *Neurology*, 30(9), p.1008.
- Prasad, H.C. et al., 2005. Human serotonin transporter variants display altered sensitivity to protein kinase G and p38 mitogen-activated protein kinase. *Proceedings of the National Academy of Sciences of the United States of America*, 102(32), pp.11545–11550.
- Quan-Bui, K.H. Le et al., 1984. Reduced platelet serotonin in depression. *Psychiatry Research*, 13(2), pp.129–139.
- Quintero, L., Cardenas, R. & Suarez-Roca, H., 2011. Stress-induced hyperalgesia is associated with a reduced and delayed GABA inhibitory control that enhances post-synaptic NMDA receptor activation in the spinal cord. *Pain*, 152(8), pp.1909–1922.
- Rademacher, D.J. et al., 2008. Effects of acute and repeated restraint stress on endocannabinoid content in the amygdala, ventral striatum, and medial prefrontal cortex in mice. *Neuropharmacology*, 54(1), pp.108–116.
- Raman, M., Chen, W. & Cobb, M.H., 2007. Differential regulation and properties of MAPKs. *Oncogene*, 26(22), pp.3100–3112.
- Ramos, A., 2008. Animal models of anxiety: do I need multiple tests? *Trends in Pharmacological Sciences*, 29(10), pp.493–498.
- Raymond, J.R. et al., 2001. Multiplicity of mechanisms of serotonin receptor signal transduction. *Pharmacology & therapeutics*, 92(2–3), pp.179–212.
- Raymond, J.R., Olsen, C.L. & Gettys, T.W., 1993. Cell-specific physical and functional coupling of human 5-HT_{1A} receptors to inhibitory G protein alpha-subunits and lack of coupling to G_s alpha. *Biochemistry*, 32(41), pp.11064–11073.
- Redila, V.A. & Chavkin, C., 2008. Stress-induced reinstatement of cocaine seeking is mediated by the kappa opioid system. *Psychopharmacology*, 200(1), pp.59–70.

- Remick, R. a and Froese, C., 1990. Monoamine oxidase inhibitors: clinical review. *Canadian family physician Médecin de famille canadien*, 36, pp.1151–1155.
- Ressler, K.J. & Nemeroff, C.B., 1999. Role of norepinephrine in the pathophysiology and treatment of mood disorders. *Biological Psychiatry*, 46(9), pp.1219–1233.
- Ribeiro Do Couto, B. et al., 2009. Social experiences affect reinstatement of cocaine-induced place preference in mice. *Psychopharmacology*, 207(3), pp.485–498.
- Ridzwan, I. E., 2012. A Single Compound Alternative to a Buprenorphine/Naltrexone Combination. *PhD Thesis, University of Bath*.
- Riedel, W.J. et al., 2002. Dissociable hormonal, cognitive and mood responses to neuroendocrine challenge: Evidence for receptor-specific serotonergic dysregulation in depressed mood. *Neuropsychopharmacology*, 26(3), pp.358–367.
- Rodgers, R.J. & Shepherd, J.K., 1993. Influence of prior maze experience on behaviour and response to diazepam in the elevated plus-maze and light/dark tests of anxiety in mice. *Psychopharmacology*, 113(2), pp.237–242.
- Rodgers, R.J. et al., 1995. Ethopharmacological analysis of the effects of putative “anxiogenic” agents in the mouse elevated plus-maze. *Pharmacology Biochemistry and Behavior*, 52(4), pp.805–813.
- Rothman, R., Gorelick, D.A and Heishman, S.J., 2000. An open-label study of a functional opioid κ antagonist in the treatment of opioid dependence. *Journal of Substance Abuse Treatment*, 18, pp.277–281.
- Roy-Byrne, P.P. et al., 2000. Lifetime panic-depression comorbidity in the National Comorbidity Survey: Association with symptoms, impairment, course and help-seeking. *British Journal of Psychiatry*, 176(MAR.), pp.229–235.
- Ruhé, H.G., Mason, N.S. & Schene, A.H., 2007. Mood is indirectly related to serotonin, norepinephrine and dopamine levels in humans: a meta-analysis of monoamine depletion studies. *Molecular Psychiatry*, 12(4), pp.331–359.
- Sacchetti, G. et al., 2001. Chronic treatment with desipramine facilitates its effect on extracellular noradrenaline in the rat hippocampus: Studies on the role of presynaptic α_2 -adrenoceptors. *Naunyn-Schmiedeberg's Archives of Pharmacology*, 363(1), pp.66–72.

- Sadler, A.M. & Bailey, S.J., 2013. Validation of a refined technique for taking repeated blood samples from juvenile and adult mice. *Laboratory Animals*, 47(4), pp.316–319.
- Sadler, A.M. and Bailey, S.J., 2016. Repeated daily restraint stress induces adaptive behavioural changes in both adult and juvenile mice. *Physiology & Behavior*, 167, pp.313-323.
- Sánchez, C. & Meier, E., 1997. Behavioral profiles of SSRIs in animal models of depression, anxiety and aggression. Are they all alike? *Psychopharmacology*, 129(3), pp.197–205.
- Sari, Y., 2004. Serotonin 1B receptors: From protein to physiological function and behavior. *Neuroscience and Biobehavioral Reviews*, 28(6), pp.565–582.
- Savitz, J., Lucki, I. & Drevets, W.C., 2009. 5-HT(1A) receptor function in major depressive disorder. *Prog Neurobiol*, 88(1), pp.17–31.
- Schank, J.R. et al., 2012. The kappa opioid receptor antagonist JDTC attenuates alcohol seeking and withdrawal anxiety. *Addiction Biology*, 17(3), pp.634–647.
- Schmittgen, T.D. & Zakrajsek, B.A., 2000. Effect of experimental treatment on housekeeping gene expression: Validation by real-time, quantitative RT-PCR. *Journal of Biochemical and Biophysical Methods*, 46(1–2), pp.69–81.
- Schmitz, J.M. et al., 2001. Naltrexone and relapse prevention treatment for cocaine-dependent patients. *Addictive Behaviors*, 26(2), pp.167–180.
- Schoffelmeer, A.N.M. et al., 1988. Mu-, delta- and kappa-opioid receptor-mediated inhibition of neurotransmitter release and adenylate cyclase activity in rat brain slices: studies with fentanyl isothiocyanate. *European Journal of Pharmacology*, 154(2), pp.169–178.
- Schultz, W., Dayan, P. & Montague, P.R., 1997. A neural substrate of prediction and reward. *Science*, 275(June 1994), pp.1593–1599.
- Schwarzer, C., 2009. 30 years of dynorphins - New insights on their functions in neuropsychiatric diseases. *Pharmacology and Therapeutics*, 123(3), pp.353–370.
- Seger, R. & Krebs, E.G., 1995. The MAPK signaling cascade. *Faseb J*, 9(9), pp.726–735.
- Sevgi, S., Ozek, M. & Eroglu, L., 2006. L-NAME prevents anxiety-like and depression-like behavior in rats exposed to restraint stress. *Methods*

and Findings in Experimental and Clinical pharmacology, 28(2), pp.95–99.

Shami, M. et al., 1983. The pharmacokinetics of mianserin. *British Journal of Clinical Pharmacology*, 15(2 S), p.313S–322S.

Sharma, S.K. et al., 2001. Transformation of a kappa-opioid receptor antagonist to a kappa-agonist by transfer of a guanidinium group from the 5'- to 6'-position of naltrindole. *Journal of medicinal chemistry*, 44(13), pp.2073–2079.

Sharp, T., Bramwell, S.R. & Grahame-Smith, D.G., 1989. 5HT₁ agonists reduce 5-hydroxytryptamine release in rat hippocampus in vivo as determined by brain microdialysis. *British Journal of Pharmacology*, 96(2), pp.283–290.

Sheline, Y.I. et al., 1996. Hippocampal atrophy in recurrent major depression. *Proceedings of the National Academy of Sciences of the United States of America*, 93(9), pp.3908–3913.

Sheline, Y.I., Gado, M.H. & Kraemer, H.C., 2003. Untreated depression and hippocampal volume loss. *American Journal of Psychiatry*, 160(8), pp.1516–1518.

Shippenberg, T.S. & Rea, W., 1997. Sensitization to the behavioral effects of cocaine: modulation by dynorphin and kappa-opioid receptor agonists. *Pharmacology Biochemistry and Behavior*, 57(3), pp.449–455.

Shirayama, Y. et al., 2004. Stress increases dynorphin immunoreactivity in limbic brain regions and dynorphin antagonism produces antidepressant-like effects. *Journal of Neurochemistry*, 90(5), pp.1258–1268.

Shopsin, B., Friedman, E. & Gershon, S., 1976. Parachlorophenylalanine reversal of tranylcypromine effects in depressed patients. *Archives of General Psychiatry*, 33(7), pp.811–819.

Shopsin, B., Gershon, S., Goldstein, M., Friedman, E. and Wilk, S., 1975. Use of synthesis inhibitors in defining a role for biogenic amines during imipramine treatment in depressed patients. *Psychopharmacology communications*, 1(2), pp. 239-249.

Simonin, F. et al., 1995. kappa-Opioid receptor in humans: cDNA and genomic cloning, chromosomal assignment, functional expression, pharmacology, and expression pattern in the central nervous system. *Proceedings of the National Academy of Sciences of the United States of America*, 92(15), pp.7006–7010.

- Simonin, F. et al., 1998. Disruption of the kappa-opioid receptor gene in mice enhances sensitivity to chemical visceral pain, impairs pharmacological actions of the selective kappa-agonist U-50,488H and attenuates morphine withdrawal. *The EMBO journal*, 17(4), pp.886–897.
- Sinclair, J.G., Main, C.D. & Lo, G.F., 1988. Spinal vs. supraspinal actions of morphine on the rat tail-flick reflex. *Pain*, 33(3), pp.357–362.
- Sinha, R., 2008. Chronic stress, drug use, and vulnerability to addiction. *Annals of the New York Academy of Sciences*, 1141, pp.105–130.
- Smith, C.B. et al., 1990. Nor-binaltorphimine is a reversible , noncompetitive opioid antagonist in the mouse vas deferens with high affinity for kappa receptors in monkey brain membranes . *Progress in Clinical and Biological Research*, (328), p.65–68.
- Solomonow, J., & Tasker, J. G., 2015. Anxiety behavior induced in mice by acute stress. *Tulane Undergraduate Research Journal*, 2, pp.14-19.
- Soomro, G.M. et al., 2008. Selective serotonin re-uptake inhibitors (SSRIs) versus placebo for obsessive compulsive disorder (OCD). *Cochrane Database of Systematic Reviews (Online)*, (1), p.CD001765.
- Sora, I. et al., 1997. Opiate receptor knockout mice define mu receptor roles in endogenous nociceptive responses and morphine-induced analgesia. *Proceedings of the National Academy of Sciences of the United States of America*, 94(4), pp.1544–1549.
- Sotelo, C. et al., 1990. Direct immunohistochemical evidence of the existence of 5-HT(1A) autoreceptors on serotonergic neurons in the midbrain raphe nuclei. *European Journal of Neuroscience*, 2(12), pp.1144–1154.
- Spanagel, R., Herz, A & Shippenberg, T.S., 1990. The effects of opioid peptides on dopamine release in the nucleus accumbens: an in vivo microdialysis study. *Journal of Neurochemistry*, 55(5), pp.1734–1740.
- Spanagel, R., Herz, A. & Shippenberg, T.S., 1992. Opposing tonically active endogenous opioid systems modulate the mesolimbic dopaminergic pathway. *Proceedings of the National Academy of Sciences of the United States of America*, 89(6), pp.2046–2050.
- Spear, L.P., 2000. The adolescent brain and age-related behavioral manifestations. *Neuroscience and Biobehavioral Reviews*, 24(4), pp.417–463.
- Spencer, R.J. et al., 1997. Mobilization of Ca⁺ from Intracellular Stores in transfected Neuro2a cells by activation of multiple opioid receptor subtypes. *Biochemical Pharmacology*, 54(7), pp.809–818.

- Sperling, R.E. et al., 2010. Endogenous kappa-opioid mediation of stress-induced potentiation of ethanol-conditioned place preference and self-administration. *Psychopharmacology*, 209(2), pp.199–209.
- Sprouse, J.S. & Aghajanian, G.K., 1988. Responses of hippocampal pyramidal cells to putative serotonin 5-HT_{1A} and 5-HT_{1B} agonists: A comparative study with dorsal raphe neurons. *Neuropharmacology*, 27(7), pp.707–715.
- Spyraki, C., Fibiger, H.C. & Phillips, A.G., 1982. Attenuation by haloperidol of place preference conditioning using food reinforcement. *Psychopharmacology*, 77(4), pp.379–382.
- Stahl, S.M. et al., 2004. A Review of the Neuropharmacology of Bupropion, a Dual Norepinephrine and Dopamine Reuptake Inhibitor. *Primary Care Companion to the Journal of Clinical Psychiatry*, 6(4), pp.159–166.
- Stahl, S.M., 2013. *Stahl's Essential Psychopharmacology*, Cambridge University Press, fourth edition, p 291.
- Stevens, W.C. et al., 2000. Potent and selective indolomorphinan antagonists of the kappa-opioid receptor. *Journal of Medicinal Chemistry*, 43(14), pp.2759–2769.
- Strang, J. et al., 2006. Persistence of drug use during imprisonment: Relationship of drug type, recency of use and severity of dependence to use of heroin, cocaine and amphetamine in prison. *Addiction*, 101(8), pp.1125–1132.
- Strekalova, T. et al., 2004. Stress-induced anhedonia in mice is associated with deficits in forced swimming and exploration. *Neuropsychopharmacology*, 29(11), pp.2007–2017.
- Surget, A. et al., 2008. Drug-Dependent Requirement of Hippocampal Neurogenesis in a Model of Depression and of Antidepressant Reversal. *Biological Psychiatry*, 64(4), pp.293–301.
- Svingos, a L., Colago, E.E. & Pickel, V.M., 1999. Cellular sites for dynorphin activation of kappa-opioid receptors in the rat nucleus accumbens shell. *The Journal of neuroscience*, 19(5), pp.1804–1813.
- Takemori, A.E. et al., 1988. Nor-binaltorphimine, a highly selective kappa-opioid antagonist in analgesic and receptor binding assays. *The Journal of Pharmacology and Experimental Therapeutics*, 246(1), pp.255–258.
- Tallent, M. et al., 1994. The cloned kappa opioid receptor couples to an N-type calcium current in undifferentiated PC-12 cells. *Neuroscience*, 63(4), pp.1033–1040.

- Tao, R. & Auerbach, S.B., 2002. Opioid receptor subtypes differentially modulate serotonin efflux in the rat central nervous system. *The Journal of Pharmacology and Experimental Therapeutics*, 303(2), pp.549–556.
- Tao, R. & Auerbach, S.B., 2005. mu-Opioids disinhibit and kappa-opioids inhibit serotonin efflux in the dorsal raphe nucleus. *Brain research*, 1049(1), pp.70–79.
- Taylor, D., Lenox-Smith, A. & Bradley, A., 2013. A review of the suitability of duloxetine and venlafaxine for use in patients with depression in primary care with a focus on cardiovascular safety, suicide and mortality due to antidepressant overdose. *Therapeutic Advances in Psychopharmacology*, 3(3), pp.151–61.
- Taylor, M.J. et al., 2006. Early onset of selective serotonin reuptake inhibitor antidepressant action: systematic review and meta-analysis. *Archives of General Psychiatry*, 63(11), pp.1217–1223.
- Tejeda, H. a et al., 2013. Prefrontal cortical kappa-opioid receptor modulation of local neurotransmission and conditioned place aversion. *Neuropsychopharmacology*, 38(9), pp.1770–1779.
- Terenius, L., 1973. Characteristics of the “receptor” for narcotic analgesics in synaptic plasma membrane fraction from rat brain. *Acta Pharmacologica et Toxicologica*, 33, pp.377–384.
- Thomas, J.B. et al., 2001. Identification of the first trans-(3R,4R)- dimethyl-4-(3-hydroxyphenyl)piperidine derivative to possess highly potent and selective opioid kappa receptor antagonist activity. *Journal of medicinal chemistry*, 44(17), pp.2687–2690.
- Thomas, J.B. et al., 2003. Identification of (3R)-7-hydroxy-N-((1S)-1-[[[(3R,4R)-4-(3-hydroxyphenyl)- 3,4-dimethyl-1-piperidinyl]methyl]-2-methylpropyl)-1,2,3,4-tetrahydro- 3-isoquinolinecarboxamide as a novel potent and selective opioid kappa receptor antagonist. *Journal of medicinal chemistry*, 46(14), pp.3127–3137.
- Thompson, a C. et al., 2000. Kappa-opioid receptor activation modifies dopamine uptake in the nucleus accumbens and opposes the effects of cocaine. *The Journal of neuroscience : the official journal of the Society for Neuroscience*, 20(24), pp.9333–9340.
- Ting-A-Kee, R. & van der Kooy, D., 2012. The neurobiology of opiate motivation. *Cold Spring Harbor Perspectives in Medicine*, 2(10) p.a012096.

- Todtenkopf, M.S. et al., 2004. Effects of kappa-opioid receptor ligands on intracranial self-stimulation in rats. *Psychopharmacology*, 172(4), pp.463–470.
- Toll, L. et al., 2016. Nociceptin/Orphanin FQ Receptor Structure, Signaling, Ligands, Functions, and Interactions with Opioid Systems. *Pharmacological Reviews*, 68(2), pp.419–457.
- Tramullas, M., Dinan, T.G. & Cryan, J.F., 2012. Chronic psychosocial stress induces visceral hyperalgesia in mice. *Stress*, 15(3), pp.281–292.
- Tzschentke, T.M., 2004. Reassessment of buprenorphine in conditioned place preference: Temporal and pharmacological considerations. *Psychopharmacology*, 172(1), pp.58–67.
- Tzschentke, T.M., 2007. Measuring reward with the conditioned place preference (CPP) paradigm: Update of the last decade. *Addiction Biology*, 12(3-4), pp.227–462.
- Ur, E. et al., 1997. The effects of spiradoline (U-62066E), a kappa-opioid receptor agonist, on neuroendocrine function in man. *British Journal of Pharmacology*, 120(5), pp.781–784.
- Ustün, T.B. et al., 2004. Global burden of depressive disorders in the year 2000. *The British journal of psychiatry*, 184(5), pp.386–392.
- Van der Staay, F.J., Arndt, S.S. & Nordquist, R.E., 2009. Evaluation of animal models of neurobehavioral disorders. *Behavioral and Brain Functions*, 5, p.11.
- Van'T Veer, A. & Carlezon, W.A., 2013. Role of kappa-opioid receptors in stress and anxiety-related behavior. *Psychopharmacology*, 229(3), pp.435–452.
- Vanderah, T.W., 2010. Delta and kappa opioid receptors as suitable drug targets for pain. *The Clinical Journal of Pain*, 26 Suppl 1(1), pp.S10–S15.
- Vermetten, E. et al., 2003. Long-term treatment with paroxetine increases verbal declarative memory and hippocampal volume in posttraumatic stress disorder. *Biological Psychiatry*, 54(7), pp.693–702.
- Victoria Milanés, M., Luisa Vargas, M. & Isabel Martin, M., 1994. Involvement of kappa-opioid receptor mechanisms in the calcitonin-induced potentiation of opioid effects at the hypothalamus-pituitary-adrenocortical axis. *European Journal of Pharmacology*, 271(1), pp.103–109.

- Volpicelli, J.R. et al., 1992. Naltrexone in the treatment of alcohol dependence. *Archives of General Psychiatry*, 49(11), pp.876–880.
- Vonvoigtlander, P.F., Lahti, R.A. & Ludens, J.H., 1983. U-50,488: a selective and structurally novel non-Mu (kappa) opioid agonist. *The Journal of Pharmacology and Experimental Therapeutics*, 224(1), pp.7–12.
- Vos, T. et al., 2012. Years lived with disability (YLDs) for 1160 sequelae of 289 diseases and injuries 1990-2010: A systematic analysis for the Global Burden of Disease Study 2010. *The Lancet*, 380(9859), pp.2163–2196.
- Wahlsten, D. et al., 2003. Different data from different labs: Lessons from studies of gene-environment interaction. *Journal of Neurobiology*, 54(1), pp.283–311.
- Walf, A.A. & Frye, C.A., 2007. The use of the elevated plus maze as an assay of anxiety-related behavior in rodents. *Nature Protocols*, 2(2), pp.322–328.
- Walker, D.L., Toufexis, D.J. & Davis, M., 2003. Role of the bed nucleus of the stria terminalis versus the amygdala in fear, stress, and anxiety. *European Journal of Pharmacology*, 463(1-3), pp.199–216.
- Wang, J.C., Kapoor, M. & Goate, A.M., 2012. The genetics of substance dependence. *Annual Review of Genomics and Human Genetics*, 13, pp.241–261.
- Weiss, J.M. & Kilts, C.D., 1998. Animal models of depression and schizophrenia. In: Textbook of Psychopharmacology. Schatzberg AF, NemeroffCB, (editors). Washington DC: *American Psychiatric Press*, pp. 89–131.
- Werlen, G. et al., 2003. Signaling life and death in the thymus: timing is everything. *Science*, 299(5614), pp.1859–1863.
- West, S.L., O’Neal, K.K. & Graham, C.W., 2000. A meta-analysis comparing the effectiveness of buprenorphine and methadone. *Journal of Substance Abuse*, 12(4), pp.405–414.
- White, M. & Hamilton, B., 2016. Trends in drug misuse deaths in England , 1999 to 2014. *Public Health England, Wellington House*
- Willner, P. & Mitchell, P.J., 2002. The validity of animal models of predisposition to depression. *Behavioural Pharmacology*, 13(3), pp.169–188.

- Willner, P. et al., 1994. Reversal of stress-induced anhedonia by the dopamine receptor agonist, pramipexole. *Psychopharmacology*, 115(4), pp.454–462.
- Willner, P., Scheel-Krüger, J. & Belzung, C., 2013. The neurobiology of depression and antidepressant action. *Neuroscience and Biobehavioral Reviews*, 37(10), pp.2331–2371.
- Winkler, C.W. et al., 2006. Kappa opioid receptor (KOR) and GAD67 immunoreactivity are found in OFF and NEUTRAL cells in the rostral ventromedial medulla. *Journal of neurophysiology*, 96(6), pp.3465–3473.
- Wise, R. a., 1982. Neuroleptics and operant behavior: The anhedonia hypothesis. *The Behavioral and Brain Sciences*, 5(01), pp.39–87.
- Wise, R.A., 2008. Dopamine and reward: The anhedonia hypothesis 30 years on. *Neurotoxicity Research*, 14(2-3), pp.169–183.
- Wittmann, W. et al., 2009. Prodynorphin-derived peptides are critical modulators of anxiety and regulate neurochemistry and corticosterone. *Neuropsychopharmacology*, 34(3), pp.775–785.
- Wong, M.L. & Licinio, J., 2004. From monoamines to genomic targets: a paradigm shift for drug discovery in depression. *Nature reviews. Drug Discovery*, 3(2), pp.136–151.
- World Health Organization: Facts sheet No 369 – Depression. Accessed on the 02 of AUG 2016a.
<http://www.who.int/mediacentre/factsheets/fs369/en/>.
- World Health Organization: The world health report: Chapter 2: Burden of Mental and Behavioural Disorders. Accessed on the 02 AUG 2016.
<http://www.who.int/whr/2001/chapter2/en/index4.html>.
- Wu, H. et al., 2012. Structure of the human κ -opioid receptor in complex with JDTic. *Nature*, 485(7398), pp.327–332.
- Xie, G.X. et al., 1994. Primary structure and functional expression of a guinea pig kappa opioid (dynorphin) receptor. *Proceedings of the National Academy of Sciences of the United States of America*, 91(9), pp.3779–3783.
- Xu, M. et al., 2007. Sciatic nerve ligation-induced proliferation of spinal cord astrocytes is mediated by kappa opioid activation of p38 mitogen-activated protein kinase. *The Journal of neuroscience*, 27(10), pp.2570–2581.

- Yan, Q.S. and Yan, S.E., 2001. Activation of 5-HT1B/1D receptors in the mesolimbic dopamine system increases dopamine release from the nucleus accumbens: A microdialysis study. *European Journal of Pharmacology*, 418(1-2), pp.55–64.
- Yasuda, K. et al., 1993. Cloning and functional comparison of kappa and delta opioid receptors from mouse brain. *Proceedings of the National Academy of Sciences of the United States of America*, 90(14), pp.6736–6740.
- You, Z.B. et al., 1994. The striatonigral dynorphin pathway of the rat studied with in vivo microdialysis-II. Effects of dopamine D1 and D2 receptor agonists. *Neuroscience*, 63(2), pp.427–434.
- You, Z.B., Herrera-Marschitz, M. & Terenius, L., 1999. Modulation of neurotransmitter release in the basal ganglia of the rat brain by dynorphin peptides. *The Journal of Pharmacology and Experimental Therapeutics*, 290(3), pp.1307–1315.
- Zahm, D.S. & Heimer, L., 1988. Ventral striatopallidal parts of the basal ganglia in the rat: I. Neurochemical compartmentation as reflected by the distributions of neurotensin and substance P immunoreactivity. *The Journal of comparative neurology*, 272(4), pp.516–535.
- Zangen, A. et al., 2001. Association between depressive behavior and absence of serotonin-dopamine interaction in the nucleus accumbens. *Psychopharmacology*, 155(4), pp.434–439.
- Zernig, G. et al., 1996. Mechanism of clocinnamox blockade of opioid receptors: evidence from in vitro and ex vivo binding and behavioral assays. *The Journal of Pharmacology and Experimental Therapeutics*, 279(1), pp.23–31.
- Zhang, S.Y. et al., 2011. Maternal restraint stress diminishes the developmental potential of oocytes. *Biology of Reproduction*, 84(4), pp.672–681.
- Zhang, Y. et al., 2009. Mu opioid receptor knockdown in the substantia nigra/ventral tegmental area by synthetic small interfering RNA blocks the rewarding and locomotor effects of heroin. *Neuroscience*, 158(2), pp.474–483.
- Zhu, C.B. et al., 2005. p38 MAPK activation elevates serotonin transport activity via a trafficking-independent, protein phosphatase 2A-dependent process. *Journal of Biological Chemistry*, 280(16), pp.15649–15658.

Zimprich, A. et al., 2014. A robust and reliable non-invasive test for stress responsivity in mice. *Frontiers in Behavioral Neuroscience*, 8(April), p.125.

APPENDIX

Exp start date: 15.9.16
 Animal ID: 13 (stress control mice).

study: 3 days SPT

		Restraint stress 9-11 Am				
		Date	15.9	16.9	17.9	18.9
Body weight			32.5	32.5	32.2	31.4
	Daily body weight (g)	0		0		
	Weight loss <5%	1			1	
	Weight loss 5-15%	2				2
	Weight loss >15%	3				
Appearance	Normal	0		0	0	0
	General lack of grooming	1				
	Coat staring, ocular and nasal discharges	2				
	Piloerection, hunched up	3				
Breathing	Normal breathing	0		0	0	0
	Laboured breathing	3				
Natural behaviour	Normal	0		0	0	0
	Minor changes	1				
	Less mobile and alert, isolated	2				
	Vocalisation, self-mutilation, restless or still	3				
Provoked behavior	Normal	0		0	0	0
	Minor depression or exaggerated response	1				
	Moderate change in expected behaviour	2				
	React violently, or very weak and precomatose	3				
Score	If you have scored a 3 more than once , score an extra point for each 3	2-5		0	0	0
	Total	0-20		0	1	2
Total score		3= Normal				

0-4= normal, 5-9=monitor carefully, 10-14= suffering, provide relief, observe regularly, seek second opinion from NACWO and/ or NVS. Consider termination.

Table 1. An example of scoring sheet for assessing animals stat during restraint stress.
 (Adopted from Lloyd and Wolfensohn, 1999).

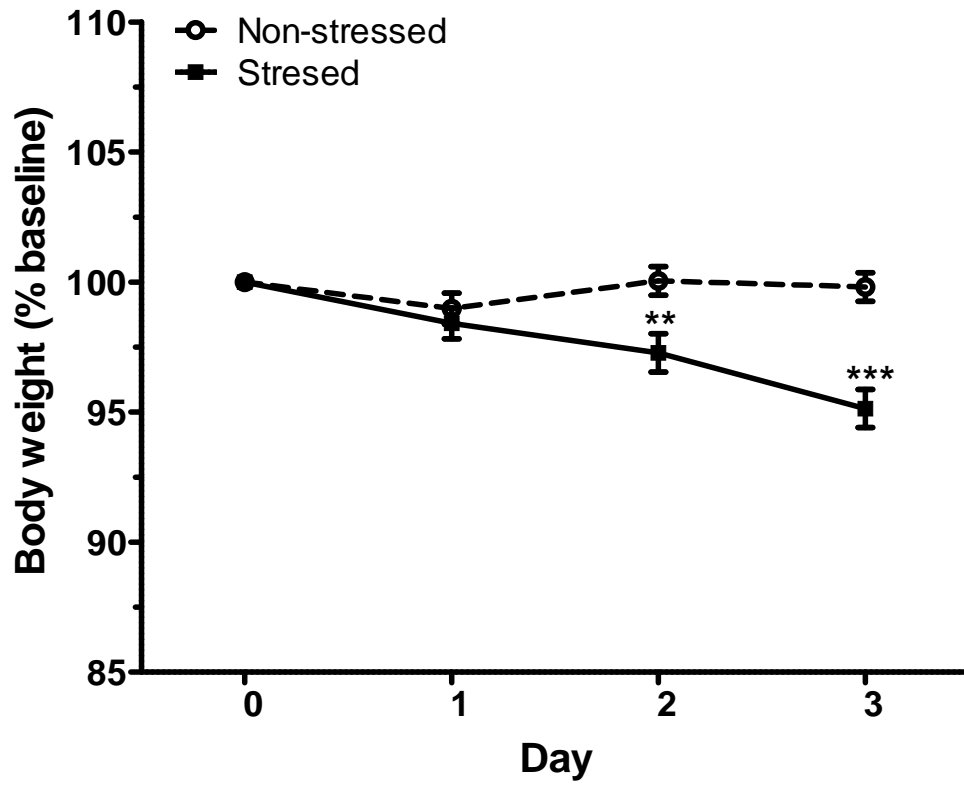

Figure 1. Effect of 3 days restraint stress on daily bodyweight of adult CD-1 male mice. Results are expressed as mean \pm SEM, n=8/group. **p<0.01 ***p<0.001 (repeated measures mixed model analysis).

Published paper

Almatroudi, A. et al., 2015. Combined administration of buprenorphine and naltrexone produces antidepressant-like effects in mice. *Journal of Psychopharmacology*, 29(7), pp.812–821.

Published abstracts

Almatroudi, A., Husbands, S. M., Bailey, C. P. and Bailey, S. J., 2014. Combination Treatment With Buprenorphine/Naltrexone, A Functional Kappa Opioid Receptor Antagonist, Produces Antidepressant-Like Effects In Mice. *Journal of Psychopharmacology*, 28 (8), A101.

Almatroudi, A., Husbands, S. M., Bailey, C. P. and Bailey, S. J., 2013. Establishing the combination of buprenorphine and naltrexone as a functional kappa opioid receptor antagonist in mice. *Proceedings of the British Pharmacological Society*

Bailey, S., Almatroudi, A. M. I., Bailey, C. and Husbands, S., 2015. The antidepressant-like effects of BU10119, a novel kappa opioid receptor antagonist, in the novelty-induced hypophagia task in mice. *In: Society for Neuroscience 2015*, 2015-10-17 - 2015-10-21, Chicago.

Bailey, S., Almatroudi, A. M. I., Bailey, C. and Husbands, S., 2014. The antidepressant-like effects of combination buprenorphine/naltrexone in the novelty-induced hypophagia task in mice. *In: Society for Neuroscience*, 2014-11-15.