

University of Bath



PHD

**Transformation and pedagogy: ICT and Pedagogy in the Context of Transformation and Design & Technology Teaching**

Booth, Anthony

*Award date:*  
2009

*Awarding institution:*  
University of Bath

[Link to publication](#)

**General rights**

Copyright and moral rights for the publications made accessible in the public portal are retained by the authors and/or other copyright owners and it is a condition of accessing publications that users recognise and abide by the legal requirements associated with these rights.

- Users may download and print one copy of any publication from the public portal for the purpose of private study or research.
- You may not further distribute the material or use it for any profit-making activity or commercial gain
- You may freely distribute the URL identifying the publication in the public portal ?

**Take down policy**

If you believe that this document breaches copyright please contact us providing details, and we will remove access to the work immediately and investigate your claim.

**TRANSFORMATION AND PEDAGOGY**

**ICT AND PEDAGOGY IN THE CONTEXT OF TRANSFORMATION AND  
DESIGN & TECHNOLOGY TEACHING**

Submitted by Tony Booth  
For the degree of PhD  
University of Bath  
2009

**COPYRIGHT**

Attention is drawn to the facts that copyright of this thesis rests with the author. This copy of the thesis has been supplied on condition that anyone who consults it is understood to recognise that its copyright rests with the author and that no quotation from the thesis and no information derived from it may be published without the prior written consent of the author.

This thesis may be made available for consultation within the University Library and may be photocopied or lent to other libraries for the purpose of consultation.

Signed by: .....

Date: .....

## **ACKNOWLEDGEMENTS**

I would like to thank my family, friends and supporters in helping me to complete this thesis.

I am especially grateful to my supervisors, Dr Stephen Gough and Dr. Chris Cloke, for their help and support throughout.

The Education department of BAE SYSTEMS was also hugely influential in helping to facilitate my case study and the Eurocollaborator project, which were conducted over a two year period from 1988 to 2000 and would have been impossible without the sustained effort of many aerospace personnel, who gave time during their busy lives to share their thinking and to work with the teachers and pupils who were involved. In addition I thank all of the people who participated in Eurocollaborator and who, while seeming to enjoy the project, generated the core data for the theorising and ideas on transformation and pedagogy. Particular thanks are extended to Chris Rogan, who was Head of Education Liaison at BAE SYSTEMS during the case study period, and to Joe Roberts, Senior Schools Liaison Engineer, who provided management for link-engineers and teachers to work on the project.

I am grateful to my family for their patience, fortitude and forbearance in supporting my extended journey throughout this experience.

## **ABSTRACT**

This research addresses pedagogy in relation to Information & Communication Technology (ICT) in secondary education. Computers have been used in classrooms for approximately thirty years, but it remains unclear whether teachers' pedagogies have changed much in consequence. Thus this research explores the transformation of pedagogy through Information and Communication Technology (ICT).

In 1998 a 2-year, multi-site case study linking teams of students and teachers within four broad UK regions was begun. A further six-year period allowed analysis of research data, to support theory building in relation to transformation of teachers' pedagogy and the conditions necessary to make pedagogical transformation possible.

The research made use of Grounded Theory within a case study methodology. Varied data were collected through my records of planning meetings with teachers and engineers during the project; of pedagogical transformation while visiting schools involved in the project; of teachers', engineers' and pupils' case study interview data where more insightful and directly focused questions on pedagogical issues from their different perspectives were involved, and of teachers' subject knowledge arising from the combined school and industrial manufacturing situated context of the project. The case study interviews involved a representative sample of those taking part in the two-year school and industry project.

Theory on pedagogical transformation has resulted from the analysis of these data. Developing this involved modelling alternative meanings of phenomena observed during the case study and developing new concepts as building blocks of the theory. I also used NVivo as a tool to help with handling the mass of raw data collected during the project and with aspects of the qualitative data management.

The research concludes that teachers may personally reconstruct their pedagogies when faced in certain ways with certain new pedagogy precedents, and develops precedence as a pre-condition of pedagogical transformation.

**TABLE OF CONTENTS**

ACKNOWLEDGEMENT

ABSTRACT

TABLE OF CONTENTS

LIST OF FIGURES

APPENDICES

	<b>Page</b>
<b>CHAPTER 1 : INTRODUCTION</b>	<b>13</b>
1.1 The context and overview of the thesis.	13
1.1.1 What was done during this research.	14
1.1.2 The outputs from this research.	15
1.2 Background to the research in this thesis.	16
1.2.1 The Chapters in this thesis.	22
1.3 The research questions.	24
1.4 My early thinking about ideas concerning transformation and pedagogy in this thesis.	26
1.5 My role and what I did during this project.	29
<b>CHAPTER 2 : TEACHERS' PEDAGOGY AND THIS RESEARCH</b>	<b>32</b>
2.1 Literature where types of precedence do not seem to be recognised.	36

## Transformation and Pedagogy

2.1.1	Historical ideas on the formation of pedagogy.	37
2.1.2	Teachers' perceptions of pupils' learning.	40
2.1.3	Teachers' knowledge structures.	41
2.2	Literature where types of precedence may have been recognised.	42
2.2.1	The broadening interpretation of teaching as a process.	43
2.2.2	Teachers' planning.	45
2.2.3	Transformation as a subject matter knowledge concept.	48
2.2.4	Teachers' thinking in relation to change.	50
2.2.5	Teachers' thinking and changes to classroom order.	50
2.3	Ways the Eurocollaborator project provided opportunities for transformation in design & technology pedagogy.	53
2.3.1	An overview of the evolution of teachers' thinking in design & technology, up to the time of the project.	56
2.3.2	The introduction of microcomputers to design & technology teaching in secondary schools.	59
2.4	Concluding ideas.	62

## **CHAPTER 3 : THE LITERATURE REVIEW**

3.1	Transformation of pedagogy facilitated by ICT: a historical perspective.	64
3.1.1	Positioning transformation and pedagogy in a historical model.	64
3.1.2	The introduction of computers to UK schools.	65
3.1.3	A broad description of the intervening years of learning with ICT in schools.	67
3.1.4	Research that does seem to further illuminate my L1 sub-question: 'How can ICT transform pedagogy?'	73
3.1.5	Some interim conclusions on the research sub-questions.	75
3.1.6	A summary of ways research and the writings of others have	77

## Transformation and Pedagogy

	bearing upon my L1 research question, “How can ICT transform pedagogy?”	
3.2	Research ideas from the later 20 <sup>th</sup> century period.	80
	3.2.1 The mandating of schools during the later period of introducing computers.	85
3.3	A review of these historical perspectives on transformation and pedagogy.	89
3.4	Ways the research questions are informed by the historical treatment so far.	91
3.5	More recent thinking on transformation and pedagogy and its theoretical underpinning.	92
	3.5.1 The current discourse on pedagogy and transformation.	93
	3.5.2 Current thinking on ICT and pedagogy.	94
	3.5.3 Origins of thinking on ICT and pedagogy.	97
	3.5.4 Challenges to defining an ICT pedagogy.	98
	3.5.5 Some theoretical underpinnings of ICT pedagogy.	99
3.6	Summary of the research questions dealt with in this section.	106
	<b>CHAPTER 4 : THE RESEARCH METHODOLOGY</b>	<b>110</b>
4.1	The research questions in the context of the Eurocollaborator project.	110
4.2	Key characteristics of a case study.	111
	4.2.1 Generalisability and the case study.	113
	4.2.2 Validity and the case study.	113
	4.2.3 Reliability and the case study.	114
4.3	The reasons why this research is a case study, and the scope of the	115

## Transformation and Pedagogy

	case study.	
	4.3.1 Scope and limitations of the research.	118
4.4	Grounded Theory and the research methodology.	120
4.5	The data collection in relation to the research methodology.	124
	4.5.1 Who collected data, and about whom was data collected?	124
	4.5.2 Why was this data collected?	126
	4.5.3 When was the data collected?	128
	4.5.4 How was the data collected?	130
	4.5.5 Criteria developed for reviewing the interview questions.	132
4.6	Ethical considerations.	133
4.7	The analytical categories in relation to the research methodology and the approach to analysis and theory building.	139
	4.7.1 Management of the qualitative data.	142
	4.7.2 Indexing the data.	143
	4.7.3 Developing the conceptual categories.	143
	4.7.4 Analytic categories developed from the data.	143
4.8	The uses of NVivo.	146
4.9	Conclusions.	150
	<b>CHAPTER 5 : ANALYSIS OF THE FINDINGS</b>	<b>151</b>
5.1	Introduction.	151
5.2	The interview data.	153
	5.2.1 The analysis of the questionnaires.	153
	5.2.2 The reasoning behind the questions.	153



Transformation and Pedagogy		
5.3	The analysis of the interview data.	154
	5.3.1 The codes and their aggregation.	155
	5.3.2 The NVivo models.	158
	5.3.3 How I dealt with the positive framing of interview questions.	158
5.4	What was said during the interviews and what was selected as especially relevant to the research questions.	160
	5.4.1 Summary of what was found out in relation to codes used and ways they were aggregated.	172
	5.4.2 The axial coding, linking the categories and concepts within the NVivo model.	175
	5.4.3 Summary of the linking process and use of Grounded Theory.	175
	5.4.4 Some pedagogy concepts that arose within the case study analysis.	177
5.5	Summary of findings.	180
	5.5.1 Summary of concepts that have emerged.	187
	5.5.2 Other forms of data that can be linked to the NVivo interview data.	187
	5.5.3 Extensions to the ideas developed within NVivo.	188
<b>CHAPTER 6 : THE SIGNIFICANCE OF THE STUDY</b>		191
6.1	Revisiting the context and overview of the thesis.	191
6.2	The research questions.	197
6.3	The research and the literature drawn together.	194
	6.3.1 The first phase of transformation and pedagogy: a period influenced by prior pedagogy practices and the concept of pre-transformation.	197
	6.3.2 Second phase of transformation and pedagogy: a period when pedagogy precedents emerge and are encountered, and the concept	199

## Transformation and Pedagogy

	of transference.	
	6.3.3 Third phase of transformation and pedagogy: a period when certain prior pedagogy practices may be altered, and the concept of form transfer.	204
	6.3.4 Fourth phase of transformation and pedagogy: a period of altered or transformed pedagogy, and the concept of precedence.	207
6.4	Key conclusions arising from the Grounded Theory approach and the final flow-logic diagram.	210
	6.4.1 Ways the research supports the key research conclusions.	210
6.5	Relationships between the literature that has been reviewed and the key research conclusions.	211
6.6	Ways the key research conclusions could contribute to more general lessons for the development of pedagogy.	213
6.7	Ways the key research conclusions might be applicable to design & technology as a subject.	215
6.8	Relationship between the key research conclusions and the research questions.	217
6.9	Concluding remarks.	221

## LIST OF FIGURES

	<b>Title</b>	<b>Page</b>
Fig. 1	The research questions.	24
Fig. 2	The research phases.	28
Fig. 3	Pedagogical transformation, precedence and the Eurocollaborator case study.	33
Fig. 4	An evolutionary portrait of transformation.	78
Fig. 5	Framework for analysing transformation, first iteration.	123
Fig. 6	Record of interview data collected during the case study.	129
Fig. 7	Framework for analysing transformation, second iteration.	151
Fig. 8	Diagrammatic representation of the linking between the interview questions, focusing themes and the research questions.	154
Fig. 9	The NVivo categories illustrated with poles.	157
Fig. 10	The common NVivo model.	173
Fig. 11	Map of correspondence between broad themes, NVivo nodes and questions.	173
Fig. 12	Comparing transformation data using NVivo.	181
Fig. 13	The framework for analysing transformation, post-NVivo, third iteration.	185
Fig. 14	The framework for analysing transformation: fourth iteration of flow-logic diagram.	196

Fig. 15	Relationship between key research conclusions and the research questions.	218
---------	---	-----

## APPENDICES

		<b>Page</b>
Appendix 1	Examples of print-based information and software resources, which I helped to develop, used to support work on the Eurocollaborator Project.	236
Appendix 2	Example of progress letter, circulated to all schools intending to participate in Eurocollaborator, from BAE SYSTEMS.	237
Appendix 3	Example of computer concept model and computer generated working drawing, used to define a plane.	238
Appendix 4	I kept a diary of my impressions when visiting schools and began to search for possible transformation. An example of an entry in this diary, which is available from the author, is provided.	239
Appendix 5	Although computer-definition provided sufficient information about a plane and its components for manufacturing to take place, the schools also arranged face-to-face meetings to discuss and run checks on exactly how the parts would fit together.	240
Appendix 6	Certain difficulties, such as with aerospace manufacturing techniques, were overcome by teams negotiating some assistance with work that could not be done in school, for example with Warwick University Rapid Prototyping Department.	241

Appendix 7	The interview questions for pupils, teachers and engineers.	242
Appendix 8	Manufacturing and Electronic Product Definition explained.	243
Appendix 9	Schools participating in the Eurocollaborator project.	244
Appendix 10	Some schools adopted more of a lead, or co-ordinating role, in each consortium and would initiate communications on manufacturing requirements and progress with other pupils in the consortium schools.	245
Appendix 11	NVivo Document Coding Report 17th May, node 1 of 33, (1.1) /issues that may influence pedagogy, passages 2 and 4 of 9: a record that shows the need for care in attributing meaning to my transformational categories.	246
Appendix 12	Explanation of ways pupils' data were analysed and considered in the research. A sample of fifty passages from the pupil data entered into NVivo, from node 27, is included.	247
Appendix 13	Computers described as belonging to a new higher level in a manufacturing evolutionary cycle.	248
Appendix 14	Ethical implications of the research, and completed MRES Declaration.	249

## 1. INTRODUCTION

### 1.1 THE CONTEXT AND OVERVIEW OF THE THESIS

The purpose of this research is to examine phenomena of transformation and impact on teachers' pedagogy where ICT was being used in a major collaborative design activity, the Eurocollaborator Project.

Teams of pupils and teachers in groups of secondary schools collaboratively designed and manufactured single products (large scale models of passenger aeroplanes) in distributed yet collaborative ways that were assisted by computer-aided means. The project was co-managed by the UK aerospace industry, BAE SYSTEMS, who helped introduce current industry practices used by their European plane-manufacturing consortia. The Eurocollaborator consortia (of schools) then designed and built scale models of single aircraft from distributed school sites over a 2-year period using similar approaches. Methods of designing and constructing the components of these scale models were dependent upon computer aided means, including computer aided design and manufacture (CAD/CAM) and for communication between the schools.

The research starts from the viewpoint that the Eurocollaborator project, which is also the case study for my research, is transformational in that it places teachers and learners in new contexts, which require pedagogical rethinking – these contexts are referred to as precedents. Further, the project evolved new pedagogical practices, theories, and beliefs. The research attempts to identify these new practices, theories and beliefs using ideas and traditions that were drawn from Grounded Theory, where the analysis of case study data included interviews with teachers, pupils, school managers and BAE engineers. There is an examination of ICT Education literature in order to identify the background to pedagogical transformation with ICT. Design & technology and manufacturing literature is also examined in order to contextualise the pedagogy in current practice, and the thinking about teaching and learning in product design and manufacture.

## Transformation and Pedagogy

The research dealt with the question of whether and how the introduction of new technology can significantly change classroom practice. Some researchers have questioned that major interventions of this kind into schooling have much impact (Cuban 1993, 2002). Others (Noss and Pachler 1999) have raised the question of how the vision of teachers might be raised beyond recycling of old pedagogies with new technology. Introduction of new technologies also requires a rethink of subject knowledge and learner skills (Heppell 1993, 233).

During this research, transformation and pedagogy have been treated as two interdependent ideas in the context of the case study (The Eurocollaborator Project). On the one hand this meant that certain principles of transformation could be posed, based upon ways people in the case study actually worked and learned. On the other hand this meant that pedagogical change that did take place could be described in transformational terms, or given transformational meaning derived from the research and analysis of case study materials.

The case study provided material on teaching and learning with ICT, while the participants worked together within a transformational framework. This framework involved teachers, pupils and aerospace engineers from different school and factory locations working together on single products. The case for this being transformation is carefully formulated and tested throughout the research, leading to conclusions that deal with the new contexts or precedents and the new practices, theories and beliefs which developed. The possible relationship between design & technology as a school subject and industrial manufacturing was examined in order to contextualise the ideas on transformation and pedagogy.

### **1.1.1 What was done during this research.**

New design & technology approaches developed through the project allowed transformation to be experienced at first-hand in the case study schools. Certain research questions were formulated concerning ways teachers translate more fundamental elements of their classroom delivery into approaches that make use of the ICT available to them, as different to other teachers who incorporated ICT via broadly unchanged classroom methods and arrangements (McCormick & Scrimshaw

## Transformation and Pedagogy

2001, 48-52). Case study evidence, including taped interviews collected from across the six consortia of schools, was analysed using NVivo. The analysis developed certain ideas on transformation of more usually preceded designing and making activity common to design & technology teaching and learning. Pupils had to learn that their particular aircraft concept was being jointly rather than individually developed, involved others in different schools and who worked with other teachers. Daily decisions in each school impacted not only on the in-school work of those involved, but also of the distributed-consortium progress because the Eurocollaborator consortium required a work-shared, rather than individual, designing and making approach.

Teaching and learning were influenced by the collaborative nature of the aircraft design and manufacture required by the case study.

The underlying themes used during this research were helpful in articulating such pedagogy phenomena in greater detail so that it could be more closely examined. The new ICT approaches allowed teachers to conceptualise a transformed design & technology knowledge and pedagogy. Certain challenges arising from the transformation were explored in terms of their impact on teachers' pedagogy and developed into theory.

### **1.1.2 The outputs from this research.**

The case study helped to develop new thinking on transformation and pedagogy, where teachers were encountering new pedagogical precedents. This allowed deeper understanding of certain principles of transformation, a new perspective to be brought to literature on ICT in education and a deepening understanding of pedagogy and teachers' needs.

The ideas on transformation and pedagogy in this thesis may also prove useful at a time when transformation has become a broad aspiration and largely un-qualified goal in national dialogue on schooling (Becta 2006). In recognising precedence as a factor in the transformation described in the Eurocollaborator project, together with how this phenomenon affected teachers' pedagogy, this research and its ideas may be useful in



describing ways of embedding new practices for teaching and learning through the use of ICT.

The Eurocollaborator project was an extraordinarily different kind of school design & technology project, initiated as a transformation of usually accepted subject practice by means of new practices borrowed from aerospace industrial manufacturing.

### **1.2 BACKGROUND TO THE RESEARCH IN THIS THESIS**

As a 0.4 seconded teacher of design & technology with the international aerospace company, BAE SYSTEMS and its affiliated secondary schools, I was able to help introduce the Eurocollaborator project and to witness some of this transformation while working at Warton Aerodrome in Lancashire and when visiting many of the schools taking part in it nationally. The project was used as a vehicle to develop the qualitative case study behind my research into transformation and pedagogy, one situated within the school subject of design & technology. The case study also set out to address a fundamental difficulty in this subject: a pedagogical difficulty in representing modern manufacturing. While describing a general outline of this work, and my particular role within it, I will also identify the research questions that are to be addressed throughout the thesis. The overview and outline begins in simplified form in this chapter, being later revisited in chapters 2, 4 and 5 in more detailed research terms. I will be talking more specifically about the basis of the research ideas into pedagogy, data collection, data analysis, particular foci that were selected within the data and the wider picture of my research.

For me personally, the Eurocollaborator project also represented a continuation of my engagement with design & technology subject development, for example from my previous secondment to the national Royal College of Art Schools Technology Project. The Eurocollaborator project was a qualitative case study that had brought teams of pupils and their teachers from different schools together into a large scale and complex collaborative plane building activity. While the design of this collaboration had been borrowed from BAE SYSTEM's aerospace manufacturing industry, it was situated mainly in the schools (and between the schools), spanning

## Transformation and Pedagogy

two academic years of curriculum and aerospace engineering education liaison development, crossing geographically distant boundaries of different school sites between the midlands and southern England and focusing design & technology subject teaching and planning into new and untried forms of teaching and learning for those involved. During the two years of its life span, the Eurocollaborator project introduced teachers and pupils to new precedents in design & technology teaching and learning, ones which helped me to develop particular insights into the world of teachers. These precedents will be explored during the analysis of the qualitative case study, the Eurocollaborator project, and will be described and explained in terms of transformation and pedagogy, terms to be tightened in new ways throughout the research. I am also asserting that the Eurocollaborator project presented pedagogy in a highly original and significant way, one especially relevant to the current period in time where the arguments for an increased use of computers in schooling hinge upon pedagogical transformation (Becta 2006).

There are some problems to overcome which result from using the word transformation here. During the early stages of my secondment to BAE SYSTEMS, when I was being introduced to schools through discussions with teachers and pupils about their perceived needs, I felt that head teachers I spoke to were interested in a transformation of school design & technology curriculum delivery to help convey ideas about modern manufacturing systems. While design & technology teachers in their schools supported this idea, they also spoke to me about their need for access to computers and to new kinds of computer-driven machinery, or explained to me that they were hoping for a project that would enrich their school workshop facilities. Pupils I spoke to seemed interested in lively teaching or the novelty of factory visits during school time, an interest that blossomed into an exciting schools-wide exhibition of their finished planes at the end of the project in July 2000. This celebration was in the form of a very large gathering, held at RAF Cottismore aerodrome in July 2000, to which all people who had been involved in the project were invited. The engineers who might be involved in this project certainly wanted teachers and schools to understand manufacturing, as it was actually conducted, in their aerospace world. But for me as researcher, the deeper understanding and framing of transformation in the context of pedagogy was the goal.

## Transformation and Pedagogy

While these early feelings and ideas, based largely on informal conversations I had with personnel and pupils at the beginning of my secondment to BAE SYSTEMS, are relevant to my argument that the Eurocollaborator project was indeed a transformation it will also be necessary to address precisely what this transformation means. While it feels very unsatisfactory at this point in the thesis not knowing what precisely transformation means, it will be necessary for the term is to be taken on trust for now. What can be said at this stage though is that this precise meaning of transformation is going to be distinct from other kinds of change.

Research has helped to develop new ideas about teachers' pedagogy, especially since the mid last century. In chapter 2, I develop ideas concerning pedagogy as a historical evolution, but as an introduction in the thesis it may be enough to say that teachers' pedagogy has been variously described and that it may be wise to think of pedagogy knowledge as being governed by different rules to those commonly accepted within other kinds of knowledge structures (Dewey 1902). It might not be wise to think of the acquisition of pedagogy in terms of the same kinds of truths observed in other kinds of knowledge, such as in science or maths, or to assume pedagogy knowledge is simply transacted to teachers through such as formal training, guidance or publications (Triggs and John 2004). This position on pedagogy has led to its origins being described by researchers and writers as complex rather than simple (Mortimore 1999, Leach & Moon 1999, McCormick & Scrimshaw 2001, Sutherland et al 2004). However, research in this thesis will examine pedagogy complexity through changes teachers describe during interviews, and through possible meanings attributed to these changes. As such, I will be attempting to describe pedagogy change with the idea of developing new constructs and terminology. I also intend to demonstrate increased rigour in describing pedagogy and transformation throughout this thesis.

The significance of the Eurocollaborator project will also be presented in ways that bring new understanding to the nature of pedagogical change, while allowing pedagogical transformation to be described. As the qualitative case study in my research, the Eurocollaborator project provided a design & technology situated view of pedagogy where ICT and computers were being introduced to teaching in different project schools, but through a particular and unusual project experience. There were

## Transformation and Pedagogy

high levels of deliberately suggested pedagogical originality in this case study, for example an expectation of collaboration between the pupils and teachers in the different schools and a reliance on using industrial manufacturing concepts, rather than more usually preceded design & technology ones, while developing aerospace products (planes) and alternative pedagogies.

The originality in this project was highly engaging for the researcher, a fact that was borne in mind and carefully developed within the BERA Guidelines in order that any extraordinary research impact remained undiminished. For example, I was able to talk to teachers and pupils in different participating schools who were engaged in a single design & technology activity that crossed the geographical boundaries of their schools. It was possible to observe, at first hand, certain pedagogical strategies used by different teachers in different schools, yet these were in fact dealing with what I believe were new and unified design & technology concepts of plane design and manufacture. This unified conceptualisation within Eurocollaborator, one through which the computer was introduced as a defining vehicle of three-dimensional form and communication, was being translated into the design and manufacture of plane parts by pupils that would need to be successfully assembled at the end of the two-year project cycle. This fact also represented an agreement in teachers' planning, one to which teachers had signed allegiance from the project outset in 1998. As researcher, my ability to move across the country between the schools, visiting the participants who were enacting a form of industrial plane manufacturing, was facilitated by BAE SYSTEMS. Here, it might be thought, the similarity with industry would have ended, for the teams were not production workers but teachers and their pupils doing design & technology work on their different plane parts in different school locations. In fact, I will be arguing that the school design & technology teams faced common problems to those of their industrial counterparts, while their experiences helped them to build pedagogy and learning that would have been difficult to develop from within the confines of individual classrooms in individual schools. An issue for this research will be to understand what difference this made to teachers' pedagogy, as well as how other research might inform the understanding of teachers' thinking when the pedagogically un-preceded is encountered. This idea of pedagogical precedence will be explained in much more detail in chapter 2.

## Transformation and Pedagogy

My earlier interest in research had developed during a previous secondment from my post as a design & technology teacher at The George Ward School, Wiltshire, to a national writing project (Royal College of Art Schools Technology Project, 1995-1997). The project had been set up by the then Technology Colleges Trust to develop new and updated texts for teaching design & technology in schools. This role involved helping to source and author new materials for these new design & technology texts, which eventually ran to seventeen separate books published by Hodder & Stoughton. Where interesting or high quality practice had been identified nationally by the Technology Colleges Trust, serving teachers were encouraged to undertake part-time research fellowships to help source materials for authoring the books, a process which had introduced me to working with a wide range of design & technology teachers nationally over the two years of that secondment.

In attempting to author new school texts I had already found that, while it was possible to write about new modern manufacturing approaches, there was still a difficulty in adapting them to suit prevailing approaches to design & technology teaching in schools. Although one more obvious difficulty for the adoption of the industrial manufacturing approaches I was writing for schools could be explained in terms of cost, for example high dependency on new and expensive kinds of computers being introduced, I felt that there were other, perhaps more significant factors that were inhibiting the representation by teachers of modern manufacturing. This included certain ways I felt pedagogic thinking in the subject had developed up to that point. This idea is important to the Eurocollaborator case study, which set out to address a difficulty in representing modern manufacturing within the established design & technology curriculum in project schools. As this is an important idea for my research, it will be re-examined and developed in more detail during chapter 2.

While I had become involved in these attempts to co-author complete curriculum packages for schools, including project source books for pupils and classroom guidance for teachers dealing with pedagogic issues (Royal College of Art 1995-7), my curiosity toward the nature of teachers' pedagogy had also increased. For example, I wanted to understand how new design & technology subject knowledge might be developed from completely new pedagogy constructs, ones that might be different to those commonly held by teachers at that point. During this thesis I will

## Transformation and Pedagogy

attempt to develop such new theoretical constructs around this phenomenon, ones that I am at this stage describing as a pedagogical difficulty in representing modern manufacturing in school.

My subsequent part-time secondment with BAE SYSTEMS and its affiliated schools network, offered an opportunity to extend the earlier work on new subject text design. However, rather than the creation of yet more new subject texts, BAE SYSTEMS and its schools network wanted to introduce modern aerospace manufacturing learning through more hands-on collaborative activity in the schools, for example through joint participation in classroom planning and teaching that involved its engineers. This situation made it possible to develop the Eurocollaborator project, both as a qualitative case study dealing with teachers' pedagogies, and as a way of exploring new manufacturing subject knowledge for design & technology teaching based upon ways BAE SYSTEMS designed and manufactured planes.

My research began to develop when these early ideas were gathered into the single overarching research question for this thesis:

‘How can ICT facilitate the transformation of pedagogy?’

I addressed this research question using a qualitative case study to show how transformation happened in a particular instance, one that was situated within design & technology teaching during the Eurocollaborator project.

Behind this over-arching research question I also wanted to adopt a broad and inclusive approach to pedagogy, one where it would be helpful to focus on teaching but also be necessary to recognise the significance of the learners in the Eurocollaborator project. This approach is broadly consistent with Watkins and Mortimore's (1999, 3, 3-15) premise for a definition of pedagogy as ‘any conscious activity by one person to enhance learning in another’. The origins of this conceptualisation of pedagogy will be examined in chapter 2 of the thesis, while the detailed design of the qualitative case study and its findings will be examined in chapters 4 and 5.

## Transformation and Pedagogy

During the 3 years of pre-planning and operational stages of the Eurocollaborator project, I then gathered data from participants in the schools and BAE SYSTEMS, largely through taped interviews and notes. I viewed my research as essentially a qualitative case study with the Eurocollaborator project as the case. In order to analyse the data and develop theory I made use of ideas drawn from the traditions of Grounded Theory where a qualitative approach was extended into the design of the questions used in the Eurocollaborator interviews. The subsequent analysis of this material was based on qualitative approaches that would help develop understanding of possible transformation of pedagogy that was taking place. The rationale behind the choice of qualitative methods was influenced by the thinking of Yin (1994) and of Strauss and Corbin (1998, 3-7) who argued that where in-depth information and understanding of unknown phenomena are required, qualitative rather than quantitative methods might be better for developing understanding. The interviews provided detail of the experiences, feelings and judgements of people (teachers, pupils and engineers were interviewed separately using specially designed questions) during the project.

### **1.2.1 The Chapters in this thesis.**

The various chapters in this thesis deal with certain stages of developing the Eurocollaborator project and case study, together with the subsequent research and a review of the significance of the study. An overview of the other chapters in this thesis, and how they fit together, is as follows:

In **Chapter 2**, I will examine relationships between teachers' beliefs, together with certain ideas which are central to this research into transformation and pedagogy. This will deal with ways teachers' pedagogy has been thought to evolve and issues concerning ways that the Eurocollaborator project was situated within the design & technology curriculum, including its relationship with industrial manufacturing approaches, ICT and how these presented an opportunity to explore concepts dealing with transformation.

In **Chapter 3** there is a discussion of the relevant literature related to the role of ICT in learning.

## Transformation and Pedagogy

In **Chapter 4**, the research methodology is discussed and the particular research design and approach taken is described.

In **Chapter 5**, there is an analysis of the findings, leading to a discussion of relevant theories and their relationship with the literature.

In **Chapter 6**, the significance of the study is discussed.



### 1.3 THE RESEARCH QUESTIONS

Fig. 1: the research questions.

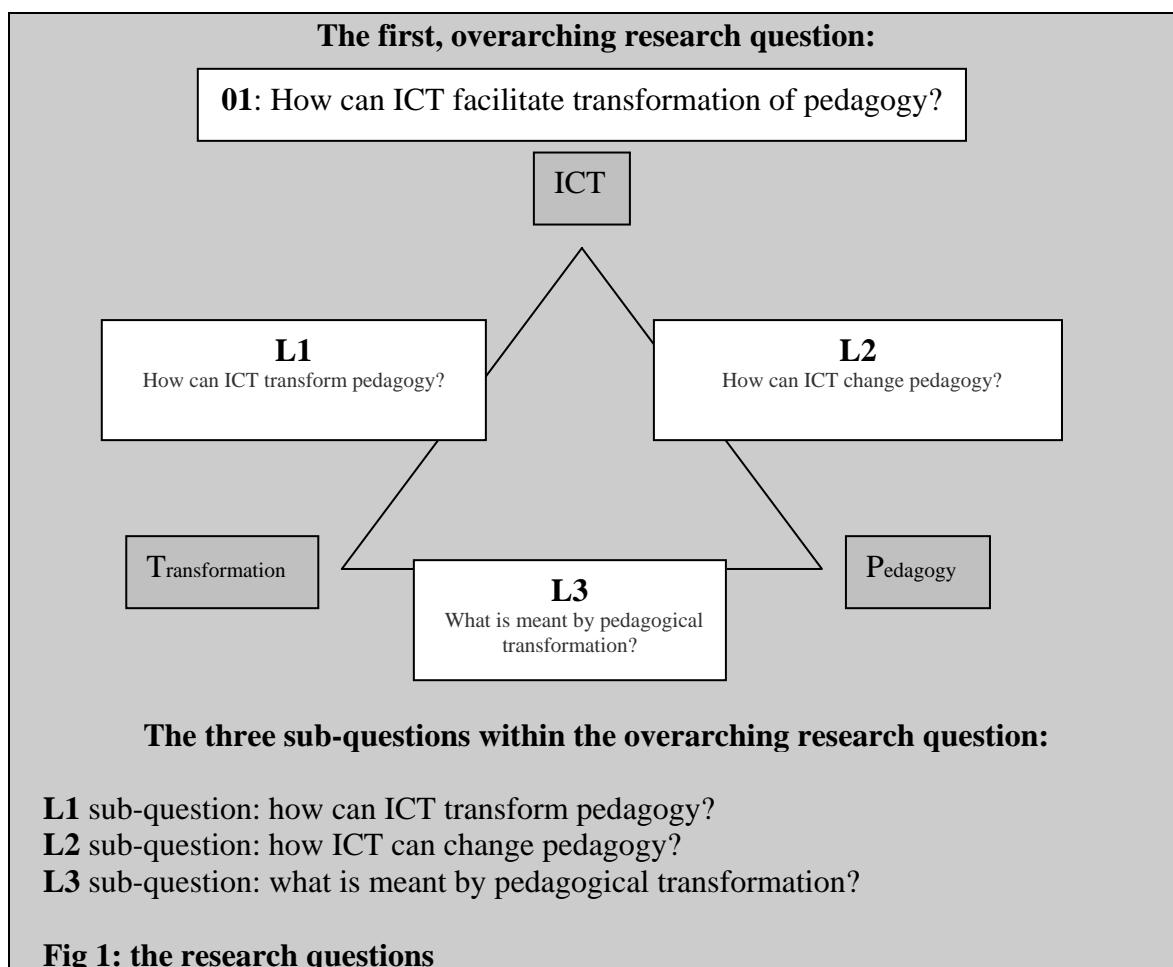

**Fig. 1, source: author**

My overall research question ‘How can ICT facilitate transformation of pedagogy?’ is shown surmounting the illustration fig 1 at **O1**, while a three-way relationship is going to be developed between three sub-questions (**L1**, **L2**, and **L3**) residing within this overall research question. The sides of the triangle in fig. 1 are to convey the idea of emphasis, illustrated here through the suggestion of dimensionality in relation to my L1, L2 and L3 sub-questions. ICT, PEDAGOGY and TRANSFORMATION are therefore positioned on points of this triangle, allowing for situations within the research to be considered as having a magnitude or emphasis within this three-way relationship and in relation to each heading.

## Transformation and Pedagogy

While the headings ICT and PEDAGOGY may be said to have an at least generally accepted meaning at this stage, I will argue this is not yet true of the term TRANSFORMATION. Early on in this thesis it will help if this less-clear idea of transformation were taken on trust, allowing it to be more fully explained in chapter 2. The idea of transformation in relation to subject knowledge and pedagogy is to be addressed qualitatively through the analysis of the case study, the Eurocollaborator project.

As already mentioned, the overarching research question has been subdivided to develop the questions for purposes of research. This overriding research question, and the three sub-questions, will be used to help focus attention on, and help interpret issues that could arise in the research. Some further explanation of these sub-questions, in relation to what I was interested in during the early stages of the research, are as follows:

### **The L1 sub-question: How can ICT transform pedagogy?**

I was interested in what is meant by transformation in the context of the Eurocollaborator project. For example, what processes of transformation, if any, were being facilitated through Information and Communication Technology approaches learned from the aerospace industry and how might different teaching situations involving these influence the pedagogy of teachers involved in the case study?

### **L2 question: How can ICT change pedagogy?**

I was interested in what ways, if any, ICT used during the Eurocollaborator project helped to change pedagogy. However, my overriding research question **01** deals with the idea that ICT can facilitate the transformation of pedagogy, as different from just changing it. This L2 question therefore doesn't actually contribute to the main research question, except to the extent that it will be used to help distinguish processes that ARE change but ARE NOT transformation, so that they can be eliminated.

### **L3 question: What is meant by pedagogical transformation?**

I was interested in how, if at all, working and collaborating with other schools during the project might affect the learning and pedagogy of those who took part. For

## Transformation and Pedagogy

example, what evidence was there that designing and manufacturing collaboratively with an electronically defined product (as different to more usual preceded design & technology approaches) had any particular influence on learning and pedagogy.

These three sub-questions are therefore dealing with the possibility of transformation (loosely defined at this stage in the thesis) in the Eurocollaborator project, together with the possible impact of this transformation on teachers' pedagogy.

In further contextualising these research questions within the anticipated later methodology sections of this thesis, I am also proposing that particular insights from the qualitative case study may help to inform our theoretical understanding of wider issues connected with transformation and pedagogy, especially ones judged or expected to follow the introduction of computers into schooling.

### **1.4 MY EARLY THINKING ABOUT THE IDEAS CONCERNING TRANSFORMATION AND PEDAGOGY IN THIS THESIS**

It was hoped that design & technology pedagogy could be evolved through the Eurocollaborator project activity; where teachers, pupils and engineers would work to a shared definition of the planes, yet perceived individually from the different schools located in their regions. Although this approach to manufacturing is now more of a requirement in modern manufacturing industry, it represented a new precedent for design & technology teaching and learning in the schools at that time. The introduction of this new precedent within a case study and project had been a deliberate decision, for example rather than the production of new printed texts just describing this kind of manufacturing.

The relationship between design & technology and the new aerospace knowledge in the project was thought to be central to the idea of transformation being studied. This examined how more usually preceded approaches to design & technology might be altered by the Eurocollaborator experience in the schools.

The hitherto practice in design & technology in the BAE Schools Network could be described as representing a cross section of national practice. A percentage of the

## Transformation and Pedagogy

secondary schools involved had attained Specialist School status under the national Specialist Schools program and had benefited from additional funding through sponsorship for the teaching of maths, science and technology. Other schools, including from the primary phase, had also received direct funding from BAE SYSTEMS to equip new facilities for teaching CAD/CAM and were developing practices for teaching and learning with these.

Design & technology teaching in the case study would encourage further development of these practices through using new Information and Communication Technology (ICT), combined with state-of-the-art plane-building approaches, assisted by BAE SYSTEMS engineers during a partnership relationship with each school developed over the two years of the project. For example, BAE SYSTEMS was keen on the idea that the Computer Aided Designing and Computer Aided Manufacturing systems that it had encouraged schools to develop could be used to explore plane-building contexts within design & technology lessons.

Between 1998 and 2000, the Eurocollaborator project had been introduced to schools within four UK regions where the work of pupils and teachers in 48 schools was focused on shared development and construction of six different Eurocollaborator planes. The decision to build six, rather than share development of just a single plane, was made by BAE SYSTEMS on manageability grounds for the participating schools and engineers. This allowed collaborative plane building to be concentrated in geographical areas of the country where pupil teams could from time to time travel to each other's schools and discuss progress face-to-face. A map of the different research phases, including the case study activity, is shown overleaf at fig. 2.

Fig. 2: the research phases

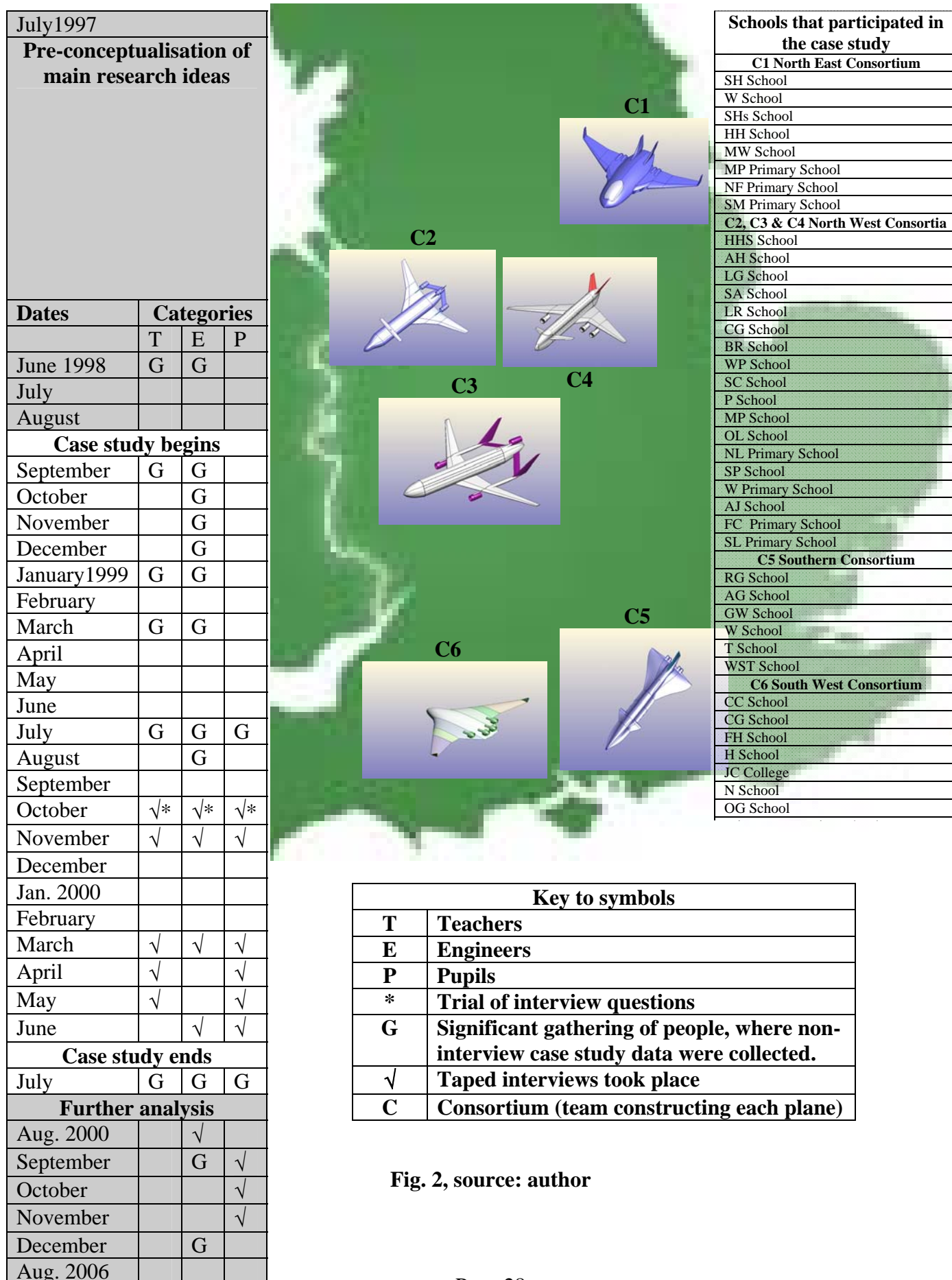

Fig. 2, source: author

## **1.5 MY ROLE AND WHAT I DID DURING THIS PROJECT**

My work with BAE SYSTEMS brought me into contact with aerospace engineers, and with teachers. BAE SYSTEMS wanted to share certain innovative approaches to plane building where new knowledge had been developed from using computers in design & manufacturing. In addition, as will be explained in chapter 2, the schools were beginning to respond to changes within the revised National Curriculum (DfES, 4c, 1995), which had stated pupils were to be ‘taught industrial applications’. These combined to kindle an interest in developing new school approaches that might be enlightened by BAE SYSTEMS engineering expertise.

In the planning stages of the Eurocollaborator project my role was to help identify ways to introduce BAE SYSTEMS’s new manufacturing knowledge to design & technology teaching in its schools network. The Eurocollaborator project was one of several proposals made to the company at the beginning of my part-time secondment to them. During the 1997-1998 period I was trying to understand the form this new knowledge might take, while at the same time I was able to visit many practising teachers in the network to discuss approaches, equipment and facilities that were being used. I began developing ideas on transformation at this time and felt that this might be experienced by teachers and pupils as a transfer from a more familiar form of manufacturing experience to another, one where different knowledge requirements would be made of people. At this point therefore I perceived transformation as a transfer from one form of knowledge to another, with a qualitative case study project (this became named ‘Eurocollaborator’) providing a transitional experience for the teachers, engineers and pupils who would be involved. The main focus of this research, however, will be teachers’ pedagogy.

The work of designing the Eurocollaborator planes for the project was undertaken by schools between September 1998 and August 1999, leaving the work of manufacturing the planes collaboratively to be completed by June 2000. By the end of this period, six consortia-designed-and-manufactured planes had been assembled, each to a 1:25 scale, which meant that they were physically quite large in comparison with more usual design & technology school projects and represented complex multi-

## Transformation and Pedagogy

school product assemblies. As with industrial practice, the aircraft had been defined electronically for the schools. This became available both in the form of computer concept models and as computer aided working drawings, generated with the assistance of the BAE SYSTEMS engineers working in the project (Appendix 3).

In chapter 4, I will provide more detail of my visits to the participating schools and factories that provided interview data. In addition to these interviews, I kept a diary of my impressions when visiting schools and began to search for possible transformation. Certain new precedents already emerging in the early stages had not arrived without frustrations, as can be sensed from this extracted example from my diary ‘Some teacher’s expectations of other colleague in other schools were frustrated. Colleagues were seen to let others down on this occasion, even though the result (e.g. a successful fit) may have been achieved. There is an issue here to do with accountability, what seems fair, that the standards of others may vary greatly, of feeling let down by others, of the pupils maybe feeling let down when they have to depend on others who are outside the controls of the particular school concerned.’ The full text of this note can also be viewed (Appendix 4), and signals the idea that new pedagogy issues might be visible through this research, ones contextualised by the introduction of industrial manufacturing approaches to a design & technology teaching that lacked precedents needed to represent them. In this instance, issues for teachers and pupils on protocols and accountabilities seemed to imply changes from prior to altered forms of design & technology. Each school-group of pupils and their teacher took responsibility for developing a component or segment of each plane. These components had to be jointly understood by the teams and built very precisely, allowing them to fit into a coherent single plane on final assembly. School-based teams manufactured these components independently, at a distance from each other and working from computer-defined information about the whole plane. Although this computer-definition provided sufficient information about the plane and its components for manufacturing to take place, the schools also arranged face-to-face meetings to discuss and run checks on exactly how the parts would fit together (Appendix 5), allowing me further opportunity to gain information from teachers and pupils working on the project on their experiences with using the new Eurocollaborator approaches.

## Transformation and Pedagogy

The overriding research question was intending to examine how ICT might facilitate the transformation of pedagogy within the Eurocollaborator Project, for example where more usual preceded design & technology practice had to be altered or where the demands of the plane building activity in the project could no longer be met by more usual design & technology approaches.

I became interested in these alterations and the idea of there being precedents, or a precedence phenomenon that might be developed as a possible principle of transformation in this research. For this idea to be generalisable beyond the Eurocollaborator project, and the teaching of design & technology, some further consideration will be needed; including ways precedents might lead to change in pedagogical practices, theories, and beliefs. This idea will be further developed as this thesis progresses.

From a purely technical perspective, rather than a pedagogical one, there were precedents that were also challenges to successfully making planes collaboratively between different pupil teams in different schools. These can be thought of as new precedents for design & technology product assembly. Where these concerned overly difficult manufacturing techniques for pupils working in the schools, it was possible to overcome the technical difficulty by negotiating specialist assistance using outside sources arranged by BAE SYSTEMS. An example was the southern consortium's use of Warwick University's rapid prototyping department (Appendix 6). However this different kind of (technical) difficulty and precedence, while of interest to this research, is subsidiary to the pedagogical emphasis in the over-arching research question, 01: How can ICT facilitate transformation of pedagogy?

In summary, my roles during this project included:

- Teacher-advisor to BAE SYSTEMS.
- Supporting school with advice and guidance for design & technology practice.
- Giving advice to BAE SYSTEMS on schools project planning.
- Participating in Eurocollaborator project management.
- Interviewer.



- Researcher

## **2. TEACHERS' PEDAGOGY AND THIS RESEARCH**

The ideas being developed in this thesis, concerning transformational precedents and pedagogy, need clarification at this point. I am testing the idea that it is possible to link pedagogy precedents and pedagogy change, and also that this may be a missing idea in the history of pedagogy. In attempting to substantiate these ideas, I will also be arguing that failure to appreciate the pedagogically un-preceded may have led to a kind of pedagogical indifference, one that has been described as a long-standing under-use of computers in schools (Cuban 1993, 2002, Heppell 1993, Noss and Pachler 1999).

A map of my intended approach to these ideas is shown overleaf, fig. 3, indicating possible new knowledge that could be developed (dashed zone). Fig. 3 can also be said to illustrate the related ideas behind my research into pedagogical transformation, precedence and the Eurocollaborator case study.

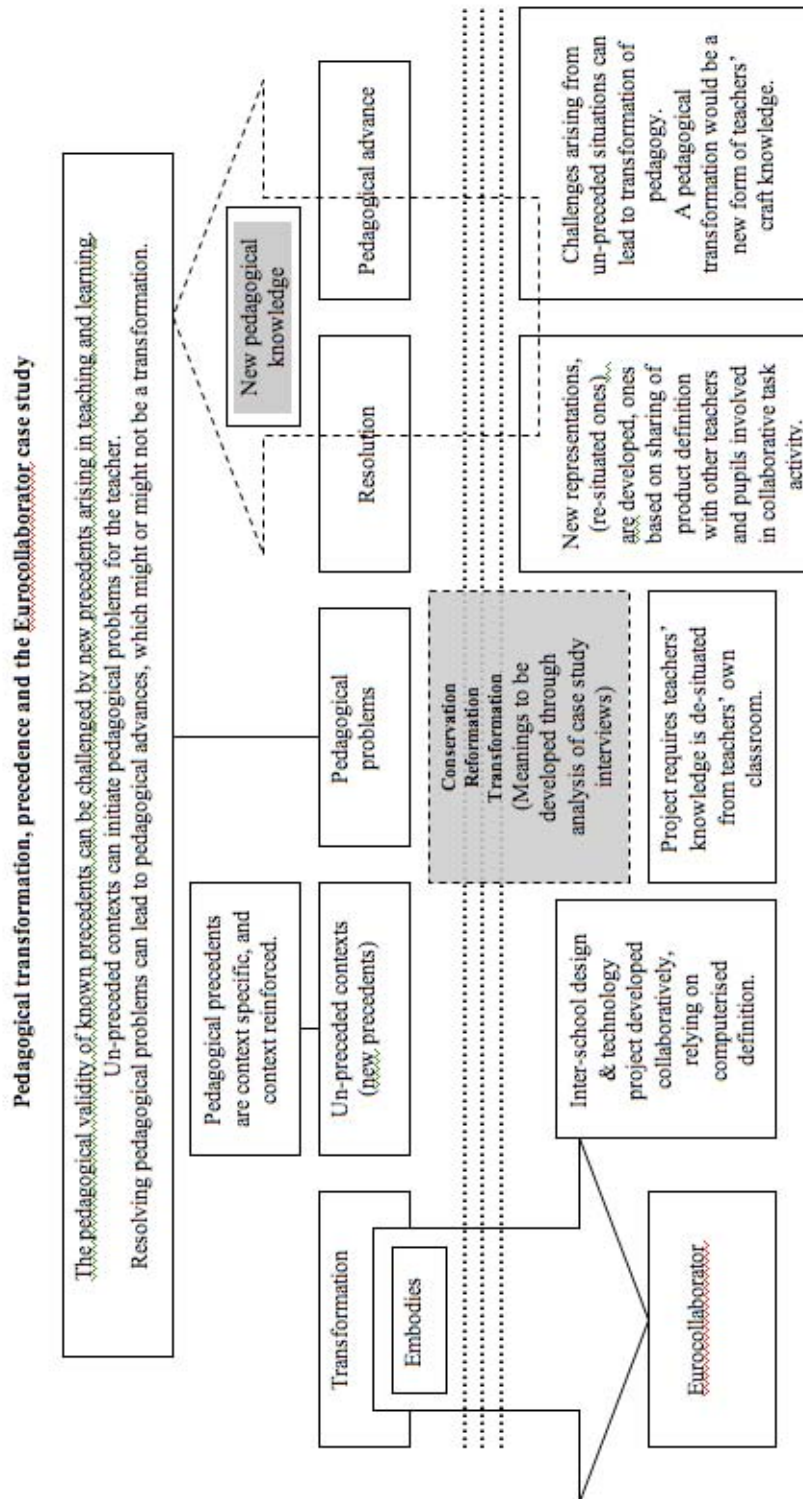

Fig. 3, source: author

Fig. 3 is designed to clarify the context of my case study research, one where ICT and computers are being used by teachers and pupils in a large-scale collaborative task, situated in design & technology teaching and in industrial manufacturing. I will be examining the idea that new pedagogy precedents, stimulated by the design of the case study, could be analysed to help develop new knowledge on the nature of pedagogy. The pedagogy precedents will also be contextualised as a difficulty in representing modern manufacturing approaches in design & technology subject teaching.

Some qualification of precedence terminology used in fig. 3 is also needed:

I am developing the idea that ICT can create new precedents that imply pedagogical problems, ones needing to be adequately resolved by teachers in their teaching, and my research is describing these precedents. The idea of precedents, at least in relation to pedagogy, does not seem to have been widely examined yet and forms the opportunity for my research. I am using the words ‘transformation’ and ‘precedent’ in a certain way here. A closer examination of this idea, one where I am arguing that there can be different kinds of precedence, will be useful before moving on.

- A precedent is defined as something going before in time, order or rank, or an earlier event or action serving as an example or guide (C.O.E.D. 2009). Something that is un-preceded can therefore be said to imply absence of such a precedent or it could be described as a new precedent for the particular persons who experience it. However, an un-preceded event or phenomenon is not the same as an unprecedented one in my research and this will be developed as a distinct idea of precedence.
- The unprecedented is defined as being without precedent, the complete opposite of being preceded, or as being unparalleled or never done or known before (ibid). This is a very sweeping idea, for example it can mean that nothing like an unprecedented phenomenon or event ever happened before or that it is a first example of its kind in every sense.
- The un-preceded is introduced here as a third, and possibly new kind of precedence. It will be associated with other ideas to be developed on

transformation. Un-preceded is an expression that has less precise meaning at this stage, one to be developed into new pedagogical ideas during the thesis. However, un-preceded needs some initial explanation at this point, the plan being to refer through it to sets of conditions or states of affairs that went before but can be said to have led to a new and unexpected pedagogical precedent. Another way of describing this un-preceded state of affairs would be one pertaining to differences between foresight and hindsight in teachers' pedagogical planning and reasoning, or where what had been planned for turned out to be different to the more usual or assumed. Examples of the pedagogically un-preceded will be sought and examined during the case study to see if they may have provided teachers with any new kinds of opportunity to adjust their pedagogical reasoning. This idea includes ways teachers could in some way be truing their pedagogical reasoning, for example from reflection on teaching in an un-preceded context. In developing these ideas more fully during the thesis, I intend to articulate new ideas and thinking on pedagogical advance and the development of pedagogical wisdom by teachers.

The essential difference between the un-preceded and the unprecedented is that, while both may lead to new and unexpected pedagogical precedents for the teacher, only the unprecedented can be thought of as the first situation of its kind to have ever existed. It is also possible to say that the pedagogically un-preceded (for the individual teacher) could arise from situations where there were known precedents but ones which, on reflection, developed in unexpected ways.

This thesis is examining these different types of precedence, and the idea that precedence may be useful in understanding ways teachers' pedagogy could be formed, further developed or even transformed. It may be that teachers' pedagogies in fact comprise practices, theories and beliefs that are founded on largely well known, or somehow well established, teaching precedents. The strategic reasons for introducing new technologies to schools, such as the idea of changing learning approaches using computerised means, may or may not in themselves lead to new theories, beliefs or the adoption of new pedagogy by teachers. On the other hand an un-preceded pedagogy experience, one where prior or well-established precedents were challenged or found no longer adequate in some way, might lead to such a

pedagogy change. Such a change could be related to the pedagogically un-preceded situation experienced by the teacher. These proposals have been broken down, as an early and simplified clarification of my thinking, into steps for illustration purposes in fig. 3, being presented from left to right.

In this thesis I am arguing that pedagogical transformation implies at least the un-preceded, if not the unprecedented, and that such transformation means a change or transfer from an earlier form to a new one. Other kinds of change might not involve such precedents, but these would not qualify as transformation in the terms described in this thesis. In fig. 3 the possibility of transformation is represented on the right hand side, in the form of new pedagogical knowledge and pedagogical advance.

The ideas of conservation, reformation and transformation are also introduced to fig. 3 to signal, at an early stage in the thesis, that certain categories will be needed to help in the analysis of the case study interview data where I will be looking for evidence of pedagogy change in relation to precedence. A substance for these meanings will be developed during this thesis, for example arising from ways the ideas I would like to develop on precedence relate to existing work on teachers' thinking and the history of pedagogy.

In further developing these ideas, it will be necessary in this chapter to examine certain literature on teachers' thinking. This examination will be in three parts:

1. Literature where types of precedence do not seem to be recognised.
2. Literature where types of precedence are, or may be, recognised.
3. Ways the Eurocollaborator project provided opportunities for transformation in design & technology pedagogy, together with descriptions of precedents in design & technology and manufacturing learning for those who were involved.

### **2.1 LITERATURE WHERE TYPES OF PRECEDENCE DO NOT SEEM TO BE RECOGNISED**

## Transformation and Pedagogy

Precedence, as a pedagogical phenomenon, is generally hard to place in early thinking within English education because the study of pedagogy was neglected or deemed unworthy of scholarly consideration until quite recently (Simon 1999).

During the later last century, ideas on teachers' thinking and knowledge structures did develop but I will argue that, even then, researchers did not consider precedence as such. Instead it was enough to examine the complexity of teachers' thinking as a re-interpretation of well-known precedents in subject content (Clark and Yinger 1987). This was unlike pedagogy challenges presented by computer aided approaches for designing and manufacturing in design & technology teaching in my research. The early research that was available can also be considered in different ways as recognising or otherwise the idea of precedence.

### **2.1.1 Historical ideas on the formation of pedagogy.**

It would seem that the English education system lacked a theory of pedagogy, or at least the historical facts suggest pedagogy had not been taken as seriously as an area worthy of academic consideration here as in other parts of Europe (Simon 1999).

Educators in Britain or North America infrequently used the term pedagogy, whereas pedagogy and didactics became the cornerstones of other mainstream European schools of thought (Leach and Moon 1999). The early English education system seems to have lacked the same underpinning of rational, methodological and systematic articulation of knowledge, which gave legitimacy to taught subjects in other parts of Europe. At the same time it has been said (ibid) that the problems of education for the middle classes were taken seriously in Europe, but not in England where the most prestigious educational institutions and private schooling largely ignored education as a subject of enquiry and study (Simon 1999).

One explanation for this apparent indifference to pedagogy in England at the end of the 19<sup>th</sup> century stems from prevailing government party-political thought at that time. The then conservative government had introduced new policies of social discipline that were designed to exert increased containment of the masses, ones counter to more rational approaches to education. Thinking behind such counter policies was

## Transformation and Pedagogy

epitomised by the introduction of a revised form of elementary education (ibid), with new Local Authority Controlled systems that could be managed centrally via a national Board of Education. This approach represented a political interruption to the growth of a rational pedagogy in England, one where the new Local Authorities were initially unable to sustain the systematic, rational approach to education that had begun to be developed during the latter part of the 19<sup>th</sup> century.

In England, the theoretical contexts through which early pedagogy did develop have been described as a period of associationist thinking during the late 19<sup>th</sup> century (Bains 1999), followed by major influences from philosophical idealism and Darwinism during the early 20<sup>th</sup> century. From the 1920s, the ensuing 40 years popularity of educational theory based on psychometry (mental testing) has also been described as a pedagogy setback, or the death of pedagogy in England during that period (Simon 1999). This was neither a climate for the study of pedagogy, nor sensitivity to precedence as a possible lever within pedagogy change.

However, the post-war period in England saw an introduction of more unified approaches to schooling (comprehensive education) and a concern by psychologists and educators for a shift from the prior static ideas to more dynamic and complex theories of child development, allowing revitalised pedagogy to develop. The recreation of pedagogic practice from the mid 20<sup>th</sup> century period allowed current ideas on the nature and psychology of pedagogy to develop.

In fact, the potential for understanding a teacher's pedagogical reasoning through early psychology had existed at the dawn of the 20<sup>th</sup> century in Dewey's (1902) ideas. These later became pivotal as an interpretation of pedagogical reasoning, where precedence also became a possible consideration. I am also arguing this opportunity has been largely missed, at least until the idea of transformation began to enter dialogue on teachers' thinking during the latter part of the 20<sup>th</sup> century (Calderhead 1987).

Dewey (1902) had postulated that every study or subject has two aspects: one for the scientist as scientist and the other for the teacher as teacher. By this he meant that these two aspects of the same knowledge, while not in conflict, were not identical.

## Transformation and Pedagogy

While the aspect for a scientist can be described as a given body of truth for locating new problems, instituting new researches and carrying them through to a verified outcome, the teacher was more concerned with the aspect of representing a given stage and phase of development of experience. The goal of the teacher is to induce a vital and personal experience in another human being, to interpret what the child currently understands and therefore needs in terms of learning. For Dewey therefore (1902) the teacher was not concerned with subject matter as such, but rather with subject matter as a related factor in the total growing experience of the pupil, “thus to see it is to psychologize it” (1902, 285-6). It can be argued Dewey’s psychologizing was new thinking on teachers’ pedagogical reasoning, one where this psychologizing process was being described in the manner of a process of transformation in teachers’ thinking.

However, while Dewey can be said to have developed ways of saying that pedagogy knowledge was different to other kinds of knowledge, describing the nature of those differences was left to others. For example, ways teachers represent knowledge for pupils as a kind of transformation processing was eventually introduced to ways pedagogy knowledge is formed in teachers’ practices, theories and beliefs (Wilson et al 1987).

This idea of transformation eventually helped to describe teachers’ pedagogical reasoning in terms of intellectual growth, or ways comprehension of content, planning and teaching were connected (ibid p113), and helped to convey some of the complexity surrounding processes by which the subject matter and pedagogy for teaching may be transformed. This was an early attempt to develop a theory of pedagogical reasoning, one where certain common aspects of the teaching act were being defined (Wilson et al. 1987). However a particular focus of such earlier research had been the then concern with teachers’ own existing knowledge base, rather than possible new challenges to the validity of pedagogy knowledge, or ways teaching and learning were conducted. This idea of challenge will be developed later in this chapter as an alternative, yet complementary conceptualisation of transformation, one where teachers’ prior thinking could be altered by new precedents occurring within an existing design & technology subject knowledge in the Eurocollaborator project.



### **2.1.2 Teachers' perceptions of pupils' learning.**

A potential for examining the idea of precedence in teachers' pedagogy developed when researchers dealing with teachers' craft knowledge became interested in ways teachers planned and interpreted their subject knowledge (Wilson et al. 1970). There was also a parallel and related interest in the manner in which teachers mediated these subject representations during classroom interaction and activity. However, the direct relevance of these ideas to my own research will depend upon the extent to which such observations of teachers relied upon instructional activity entirely under the control of the teacher in her own classroom, as different from the Eurocollaborator project which depended upon a more distributed responsibility for what the class actually did, for example with different pupil teams and teachers in different schools working on the same electronically defined product.

While some of the 1980s thinking on pedagogy was beginning to attribute transformation to a special kind of conceptualisation of knowledge through teacher processing, other work was beginning to examine teachers' conceptualisations of their pupils' learning from observations in the classroom situation, and therefore how pupils' needs, or readiness for such transformations, were actually interpreted by teachers. For example, how teachers explained their pupils' difficulties and their understanding of subject matter was examined as a core of teachers' real task (Bromme 1987), leading to new ideas on the nature of teachers' practical knowledge. This involved examination of classroom variables, together with ways these could be categorised, described in terms of teachers' situation-specific views of their pupils. However I have found little mention of precedence in the situations analysed. Bromme's research (1987), which was based on research into US classroom instruction in mathematical tasks, was dealing with teachers' post-lesson recollections of events, as a means of revealing more of a focus on the entire class and of instructional flow of the lesson. This was an important idea, offering the possibility of considering teachers' perceptions of pupils' understanding in hindsight. However, at this point there was a greater concern to consider how transitions from old to new

knowledge for the class were actually decided by the teacher and how that had a more complex basis than had previously been thought, for example as a psychological task-framework of demands placed upon the teacher in the classroom. But while this focus on how teachers' perceptions were actually shaped represented a shift away from more simplistic prior models of teacher as manager of an abundance of facts (Bromme 1987, 138), there is little to suggest that new precedents were a consideration.

Cognitive psychologists at that time were, in fact, interested in the process of acquisition of knowledge. This included: ways in which pupils' existing pre-conceptions of subject concepts were reconstructed; the role of teachers' meta-knowledge; ways pupils' earlier insights became restructured in the light of new information being taught; ways teachers were able to combine considerations of the subject matter with their experience of difficulties in student understanding; and, the idea that teachers had a less direct effect on learning than previously thought (Bromme 1987, 139).

These were important steps in our understanding of how teaching stimulated learning, for example by reactivating the potential structure of pupils' old knowledge alongside the introduction of new knowledge, while at the same time noticing pupils' problems (Bromme 1987). But precedence as a means of pedagogical advance was not an issue here, instead a teacher's professional knowledge began to be defined in terms of extending to cope with difficulties in instructional flow, for example where the student's ideas and lesson interactions were developed into objects of explanation. This can be described as a conception of pedagogy based upon teachers' more usual preceded ideas. Instead, I will attempt to extend some of these ideas through a further complexity, one where the responsibility for instructional flow within the case study was not entirely that of the individual teacher but was also being influenced by the wider consortium of other pupils, teachers in neighbouring schools and the non-teacher engineers who were active within the Eurocollaborator project.

### **2.1.3 Teachers' knowledge structures.**

The thinking already mentioned on teachers' transformations of their subject knowledge, for example through constructing representations of knowledge for their pupils (Wilson et al. 1997), led to an interest in ways pupils' comprehension could be described as a constructive process in response to the teachers' planning and decision making. The introduction of precedence to these ideas, developed from analysis of data for the Eurocollaborator project, will be used to examine differences between teachers working independently in their own classrooms and working collaboratively while observing certain project givens. For example a teacher working within her own classroom, and dealing mainly with more usual preceded practices and subject routines, would be unlikely to experience the new precedents presented by the Eurocollaborator project, ones which in this case further increased complexity by introducing teachers and pupils to innovative and collaborative plane manufacturing approaches where the computer had become a fundamental tool.

In summary it can be said that, after early setbacks, theory of education during the last century was recognising an increasing complexity in teachers' thinking, one that aroused research interest. The idea that teachers hold and use implicit knowledge in responding as they do in classrooms, informing their planning and decision making, suggested that teachers' knowledge structures themselves could be analysed (Carter and Doyle 1987). However, the ideas of precedence being developed in my thesis were at best un-developed by others. At this early stage there was more focus on understanding how teachers managed the establishing and maintaining of social order in the classroom, and of representing a more usual preceded curriculum, tasks to be accomplished interactively but largely in more conventional classroom contexts when compared with the Eurocollaborator project.

### **2.2 LITERATURE WHERE TYPES OF PRECEDENCE MAY HAVE BEEN RECOGNISED**

As has already been mentioned, with the declining popularity of behaviourist psychological thinking from the later last century period, it became possible for precedence to be a consideration within research into teachers' thinking and pedagogy. However this possibility did not develop until recently, for example Leach and Moon (1999) have asserted that pedagogy ought to be considered within certain

pedagogic settings (Leach and Moon 1999, 267). Here a theory of pedagogy would need to encompass all complex factors that influence the process of teaching and learning, as well as to recognise that in creating and sustaining pedagogic settings teachers crucially determine both the nature and quality of learning. The broader idea of settings is perhaps more consistent with the idea that precedence could be a factor in pedagogy change. This idea will be developed in this thesis in terms of particular Eurocollaborator case study settings, meaning that teachers were also helping pupils to relate to a broad set of project responsibilities, rather than ones developed personally by the teacher and under the teachers' sole control, as in more usual preceded pedagogy settings.

Leach & Moon (1999) also asserted that within such settings a broad understanding of the human mind and cognitive science, as currently understood at any point in time, seems to be a crucial aspect of teacher knowledge. This thesis will explore the idea that the new precedent of different pupil groups and their teachers in different schools, working concurrently on the same (electronically-defined) product, held the potential for teachers to develop new pedagogy knowledge. An un-preceded situation would now need to be represented by teachers, one that was different to pupils mainly working on their own individually defined products where design and manufacturing decisions could be made more personally and to suit the individual's own needs. The new need, to appreciate that progress in a neighbouring school had real-time bearing on ones own designing and making processes, could become pedagogically significant. Teachers and pupils could no longer work in the more individualised way to which they had perhaps become more accustomed in school, and had now instead to appreciate that the progress of others had become a factor in their own design & technology learning.

However, the more recent ideas on teachers' thinking was suggesting a broader interpretation was needed of how teachers' existing knowledge base is related to ways teaching and learning is conducted (Wilson et al. 1987)

### **2.2.1 The broadening interpretation of teaching as a process.**

## Transformation and Pedagogy

During the 1970s, dissatisfaction with earlier behaviourist approaches to the study of teaching began to develop in the psychology of education (Calderhead 1987).

Ideologically viewing teachers as active agents in the development of their own practice, and as decision-makers using their specialist knowledge to guide their actions in particular situations, militated against the previously dominant view of teaching as the mastery of a series of effective teaching behaviours (ibid).

Interest in the idea of transformation also begins to appear in educational writing during this period, there being a need for more sophistication in describing complexity in teachers' thinking (Clark & Yinger 1987, Wilson et al. 1987). The attempts to unravel the actual nature of teachers' thinking, its origins and how it might develop through examining teachers' own planning processes (Calderhead 1987), led to a broadening of the active research fields in education, one including the fields of sociology, philosophy and anthropology, and an interest in teachers' craft knowledge (Zeichner et al. 1987). For example teachers' perspectives toward teaching, including their personally held systems of beliefs, values and principles, was examined within social contexts of US trainee teachers' classroom teaching (ibid). This research, while troubled by certain inconsistencies it uncovered in teachers' thinking, drew in a range of other kinds of research to examine socializing, evolutionary and psychoanalytic agents of teachers' thinking (Zeichner et al. 1987, 23). Here, differences between kinds of theory trainee teachers were being exposed to during pre and initial training, and what they were actually saying about their beliefs in the context of the classroom world, led to the idea that teachers' craft knowledge could not be represented as an occupational and cultural uniformity. This was shown to be true even within single schools (Zeichner et al. 1987), and led to the idea that the nature of teachers' craft knowledge was subtly influenced by ecological conditions in the classroom and influenced by the underlying design of University training schemes. The ecological idea here (ibid) was more consistent with my ideas on precedence, because in describing teachers' thinking in evolutionary terms, there was more focus on ways teachers might adapt their thinking to possible new conditions in the classroom. This idea is also represented in the ideas of Giroux and others of the so-called Frankfurt School (Giroux 2003) in which the claims of any theory must be confronted with the distinction between the world it examines and portrays, and the world as it actually exists. For Giroux (ibid) this meant studying the relationship between theory and

society, while implying that there were important mediations that linked the institutions and activities of everyday life with the commanding forces shaping a larger social totality. These arguments, while interesting for the suggestion that teachers incorporate informal curriculum into their perspectives and pedagogy, suffered from the difficulty of substantiation and lack of strong empirical evidence (Zeichner et al.). However, Giroux's ideas can be used to help explain certain issues within the evolution of design & technology subject knowledge, an idea that will be developed later in this chapter. They also allow alternative possible perspectives to be described concerning the pedagogies implicit within the Eurocollaborator project, for example to compare teachers' experience of the project in both the ecological terms of existing design & technology approaches with an intervention of industrial manufacturing approaches to subject knowledge. Later in this chapter this approach will be used to develop contrasts and descriptions of the Eurocollaborator design & technology subject knowledge schema and their possible influence on teachers' pedagogy.

### **2.2.2 Teachers' planning.**

While teachers' planning could be treated as a psychological process, for example giving more scope to the idea that teachers' mental lives introduced and helped to order ways learners encountered conditions of classroom learning, there was the problem of describing how teachers actually mediated subject knowledge. A difficulty here was in actually observing mediation, but it was during this period that early references to transformation as a process of teachers' craft knowledge began to appear. However, this was a particular interpretation of transformation, one of questionable terminology. For example, a teacher may be said to interpret subject knowledge to suit a learners' need at any one point in time. But is this a transformation of teachers' craft knowledge, or is it something in the learner's experience that is transformation? What I am suggesting here is that this process could, at best, be described as a transformation within teachers' craft knowledge, rather than of teachers' craft knowledge, and that even here a transformation as such may be questionable. The importance of this distinction, in further elaborating the nature of pedagogy, is an idea that will be developed throughout this thesis.

## Transformation and Pedagogy

Teachers' planning processes became a popular research phenomenon during the 1980s, possibly because these seemed more tangible than other aspects of teachers' thinking. Planning was also thought to link curriculum to instruction in more observable ways (Clark & Yinger 1987). This direction of research into teachers' planning was a rejection of more simplistic prior notions of effective teacher behaviours. Instead, the full complexity of teachers' task, the teachers' frames of reference and the importance of describing the thinking and planning of teachers was addressed (Clark and Yinger 1987). Different ideas about different types and functions of teachers' planning were beginning to be considered, leading to new conceptualisations, for example yearly, termly, weekly, unit and daily; together with the differences in importance teachers ascribed to these (Clark and Yinger 1987, 87). Such kinds of teachers' planning became described as problem spaces within which teacher and student operate, ones that may be defined early and change little during the course of the school year, exerting a powerful and subtle influence on thought and behaviour.

While these ideas do not refer directly to precedence, they can be said to allow for the possibility of its effect on pedagogy, for example that teacher planning decisions did not in fact always follow linearly from specification of objectives and that few teachers seemed to be following an integrated ends-means model in their planning (Clark and Yinger, 90), the nature of teachers' planning being found difficult to describe in any systematic way.

Speculation on when teachers actually thought about objectives, rather than how they planned (Clark and Yinger 1987, 93), led to elaboration of some of this complexity, finding that teachers can be observed to think about and act to support both specific and general learning outcomes for their pupils within the context of interactive teaching and in post-active reflection. This idea of a reflection, one in hindsight of fore planning, is at least consistent with the ideas of precedence being developed in this thesis.

It was being argued that a function of teacher planning was to transform and modify curriculum to fit the unique circumstances of each teaching situation (Clark and Yinger 1987), stimulating researchers' interest in teachers' reasons to plan, types of

planning and further professional development. However, at this stage in the thinking about transformation, a focus was mainly on ways teachers could convert formal units of instruction, for example as might be found in a teaching manual or scheme of work, into plans and attendant classroom behaviour while teaching the unit. In other words, the perceived transformation was an interpretation of the curriculum unit and teachers' preparation of it for actual classroom use. A transformation was being perceived as this act of interpretation by the teacher for the pupils being taught.

While the idea of precedence might be accommodated within such thinking, the interpretation placed on transformation will be questioned in this thesis. A purpose of my research will therefore be to further develop this interpretation of subject content and sequences of instruction as transformations, for example in situations other than more usual preceded ideas and adaptations of existing curricula into instructional activity. My case study will be used to examine what part teachers' planning and pedagogy would play in teaching and learning, where a transformation arising from the use of ICT would be encountered by teachers and their pupils. This would instead involve working within the un-preceded situation of Electronic Product Definition (Broughton et al 1995), of the design and technology product they were constructing. This idea of a transformation, one involving responses to new precedents in design & technology subject teaching influenced by new industrial manufacturing approaches, will be developed throughout this thesis.

As researchers grappled with the difficulty of predicting teachers' classroom behaviour from prior planning (Clark and Yinger 1987), the idea of teacher as a professional thinker was encouraged by a new cognitive psychology that was helping to address and understand the phenomenon of teacher cognition. The observation that teachers were found to draw upon (perhaps implicitly) thoughtful and systematic notions about pupils; subject matter, teaching environments and teaching processes, and where idiosyncratic contexts could require the joint construction of meaning; depicted the teacher professional as a reflective rather than controlling being. This position argued for a greater understanding of the relationship between teacher reflection and action (Clark and Yinger 1987, 98). The goals of research into teaching, and the image of teaching at this point, became influenced by a shift toward promoting professionals own understanding of self, with reflection playing the major



role, rather than of developing a theory of practice for the teacher. The growing interest in the idea of providing teachers with new kinds of knowledge base, including ideas about subject matter knowledge and the role that it was thought to play in teaching, provides a basis for my idea that types of precedence could also be recognised as being significant to pedagogy.

### **2.2.3 Transformation as a subject matter knowledge concept.**

Theory began to be developed at this time on teachers' interpretations of subject knowledge and how this could be modelled. Transformation was developed as a core concept, and kind of transfer of one form of learners' understanding into another form, one evolving from development of the learner's previous understanding.

Teachers' ways of representing subject matter knowledge, and the influence of these representations on instruction, came to be a research focus on teachers' thinking (Wilson et al. 1987), and this work led to the development of certain ideas about transformation of the teacher's subject knowledge. In attempting to more clearly understand teachers' knowledge of learners, certain relationships between pedagogy and the subject matter knowledge of curricula were developed. This work by Wilson et al. (1987, 95) had identified the complexity of teachers' planning, including its pre-active and interactive stages and the constant decision making required of teachers when engaged in planning and instruction. This idea is consistent with, though not the same as, the ideas on precedence developed in this thesis because of the relationships being developed between teachers' fore planning and hindsight reflection, which I will be describing as the un-preceded in transformation.

In fact, research had yet to find a consistent relationship between what teachers knew and what pupils learned, a problem being blamed at that time on the failure to operationally define teacher knowledge (Wilson et al. 1987). The ideas concerning precedence being tested in this thesis can be described as an aspect of this relationship between what teachers knew and what pupils learned, one placed in the context of a transformation in design & technology subject teaching.

## Transformation and Pedagogy

This perceived gap in the literature on what teachers knew about their subject matter, and how they chose to represent that subject matter during instruction, was described by Wilson et al. as 'the missing paradigm' (1987, 108). Their efforts to overcome this gap led to new research and theory on how subject matter was transformed from the knowledge of the teacher into the content of instruction (Shulman 1986), and became articulated as a transformation-of-knowledge theory of pedagogical reasoning.

Shulman's (1986) perspective of teachers' thinking included the idea of knowledge passing into knowledge-representations appropriate to learners, a process described as transformation of subject knowledge. The transformational passage of this subject knowledge was enacted by teachers through their ability to represent their subject matter via deeper understanding of topics, for example by invoking basic concepts, principles, and themes that could link knowledge structures or conceptual schemas. Shulman's ideas (1986, 4-14), helped develop thinking on ways in which teachers' knowledge of the subject could be organised, for example ways it might be stored in clusters and schemata, and contributed to broadening of thinking on how humans translate their experiences into internal representations (Gardner 1986).

While other researchers sought alternative and complementary explanations of teachers' thinking (Carter and Doyle, 149), there was an underlying idea that a complete model of the management task in the classroom could be built using psychological terms. However, the describing of teachers' representations as psychological enactments brought sophistication to the theoretical understanding of classroom management. For example, teachers' adjustments to the activity flow of a class could now be described in terms of helping pupils traverse difficult learning terrain, or as a kind of redefining of the curriculum where teachers created familiarity to reduce the amount of intellectual effort needed by pupils (Carter and Doyle 1987). This approach to explaining teachers' thinking implied that the logic of classroom management was at least as important as the logic of the subject content in lessons, ideas that were linked to certain Vygotskian concepts on the nature of learning such as the idea of that teaching was ideally a proximal task in response to pupils' perceived learning needs (Vygotsky 1986). Ideas on defining better teaching began to develop along lines of reflective, critical practice, with a knowledge base that included the craft knowledge of skilled practitioner from the classroom and

propositional knowledge arising from classroom research and the social and behavioural sciences.

### **2.2.4 Teachers' thinking in relation to change.**

As the particular kinds of precedence I am examining arose from the uses of computers in design & technology, and as computers had already been introduced on at least a limited basis by the late 1980's, it would be surprising if such precedence was not mentioned in research from this period. But while teachers' internal conflicts had become a Freudian psychotherapeutic theme in some research (Wagner 1987), the possible effects of computers on pedagogy, such as new precedents they might bring about, were as yet a limited consideration. In the subject teaching of design and technology, I will be suggesting that computers became a source of new subject knowledge because of ways the computer had changed industrial manufacturing, a change that should have had pedagogical implications (yet did not have, or not very much), as will be explained later in this chapter. This failure meant that the development of design & technology teachers' pedagogic thinking occurred in ways that have led it not to reflect modern manufacturing and instead a single mindedness on designing and making (Kimble 2002).

### **2.2.5 Teachers' thinking and changes to classroom order.**

I am asserting that much of the earlier research into teachers' thinking was making assumptions about teachers' pedagogy that I will later describe as conservational, for example being based on the idea of teacher in control of a stable and broadly unchanging subject knowledge, rather than transformational where knowledge might indeed be expected to change. It is also important to emphasise that here, I am using the terms 'transformational' and 'conservational' in the special ways already referred to at the beginning of this chapter, in other words as a special description of precedence which will be useful in the analysis of the case study data and the development of new thinking.

## Transformation and Pedagogy

In fact research involving early introductions of computers into schools did exist, but needs careful treatment and interpretation. While the mid 1980s may have been a period when issues arising from computers were less clear than today, the perceived responsibility for identifying and enacting classroom change can also be shown as having been left largely to individual teachers during this early period.

A psychological cognitive perspective can be shown to have steered some early research on the introduction of computers, such as in examining how teachers personally construe the classroom and the relevance of their personally held constructs to ways change might be introduced (Olson and Eaton 1987). This work came at a time when the idea of planning change sympathetically to teachers' personal constructs was still novel. In fact, earlier change-strategies were being rejected as unduly systems-based or as founded on technical rationality, rather than taking account of teachers' reasons why classroom order actually existed (Olson and Eaton 1987, 179), and described as an ecological conception of change in cases where early microcomputers were being introduced. This meant the significance of teachers' work being more fully taken into account.

While early attempts at introducing micro-computers to schools must be appreciated in the context of the initial difficulty in procuring them and their high cost (Easterton 1982), and the early understanding of them, Olson and Eaton's (1987) case study explored such change by examining the espoused theories (Schön 1987, 255) of eight teachers who voluntarily attempted to introduce computers into their classrooms. The espoused theories of these teachers were described as dealing with two general categories of teacher-rationale, a) treating Information Technology as a subject in its own right and b) treating Information Technology as an impact on learning in the subjects they were already teaching, including effects and un-anticipated consequences. The ecological context of this research meant describing pedagogy in terms of teachers evolving their own local classroom conditions, being largely unguided and free to work as they pleased, and where research ideas were developed in part from analysis of the notes these teachers kept in logs on their experiences. Through analysing teachers' interpretations of their classroom experiences with computers, it was hoped to more clearly understand ways teachers might be

## Transformation and Pedagogy

attempting to cope with modern and unfamiliar technology using familiar, well tried routines and responses that might not always work (Olson and Eaton, 1987).

While Olson & Eaton's (1987) research identified the need for a well-developed curriculum rationale against which teachers could test their own ideas, it stopped short of describing a transformation of pedagogy as such. Instead, a categorisation of 'routine' and 'novel' elements using computers was proposed (ibid p189), a kind of categorisation that has been revisited in transformational terms by others since then (McCormick & Scrimshaw 2001). Olson and Eaton's (1987) article may have implicitly recognised the idea of precedence, articulated along psychological lines where a tension might develop between teachers incorporating elements of innovation or novelty alongside well-established routines. This led them to argue for an approach where, rather than substituting one pedagogical approach for another, there could be a challenge posed by another well conceived practice to an existing practice, one where a critical comparison could be allowed for the teacher. This psychological idea, that introducing computers might represent a risk to teachers' well established practices and where significant change to pedagogy would require a reassignment of meaning to new practices by teachers, begins to articulate the idea that challenges to teachers' prior practices were dialectical processes involving evaluation and re-evaluation of new practices, or critical assessment.

The ecological emphasis within Olson & Eaton's (1987) research suggested the rightful responsibility for assessing the educational value of computers lay with the teacher, the person who most directly confronts the educational tasks of school. However, it presented computer innovation as a largely social/ psychological interpretation of existing teaching processes, rather than as transformation. My research into the Eurocollaborator project will instead consider computer innovation as one of introducing the un-preceded in teaching processes, such as pupils responding to project-controlled and project-communicated information, with certain obligations and responsibilities to act on such information as project givens. This project obligation, for example the observance of accurate production needs when manufacturing modern concept aircraft by diverse and geographically dispersed groups of pupils and their teachers to a more precise definition, was to be a new practice resulting from the combined efforts of different school-based teams working

with new kinds of unambiguous information about the product. The ways such new precedents affected teachers' pedagogy will be examined to see if such focusing of teaching and learning with that of other school-based teams using the same computer definition of the product, may have challenged teachers' more usual preceded teaching methods.

### **2.3 WAYS THE EUROCOLLABORATOR PROJECT PROVIDED OPPORTUNITIES FOR TRANSFORMATION IN DESIGN & TECHNOLOGY PEDAGOGY.**

Earlier in this chapter I introduced the idea that pedagogical wisdom might be describable as a truing of ideas in response to the un-preceded, and that the Eurocollaborator project would be designed to stimulate such pedagogical processes so that they could be examined more closely. The general idea of truing in this thesis can be described as a means to becoming comfortable to fact or reality, or the bringing into exact shape or position required (C.O.E.D. 2009), and is an idea that will be developed as pedagogical change in response to the un-preceded during the analysis of the case study data.

I also take the position in this thesis that subject knowledge development would probably be involved in any transformation of pedagogy. Being situated in design & technology subject teaching, it is necessary to examine certain conditions in subject knowledge development that had preceded the Eurocollaborator project, together with how this might lead to challenging of more usual preceded design & technology subject knowledge.

Earlier in this chapter I asserted that design & technology did not represent modern manufacturing (it can also be argued that this continues to be the case). This was because the development of pedagogic thinking had occurred in ways that have led it not to represent modern manufacturing, the particular reasons for which are examined next. In this chapter the possibility of pedagogy advance and transformation is developed by showing how certain sets of conditions or states of affairs, ones rooted in well known design & technology knowledge, could justifiably be described new precedents arising during the case study. It will also be necessary to explain what

## Transformation and Pedagogy

these sets of conditions meant in the context of more established design & technology knowledge which had been developing during an earlier historical period.

It will be argued that changes to teachers' methods, resulting from the Eurocollaborator project, became unavoidable project givens. It is possible to restate this idea in the context of Eurocollaborator as follows:

Where a design & technology situation whose scale (passenger planes are large products) and complexity (planes are very complex and expensive to build) is of an un-preceded nature (pupils and teachers were unfamiliar with aerospace product definition) the experience of learning through a more familiar design & technology capability process (which may have worked well in past design & technology situations) could be challenged by the need to adopt new learning strategies. Certain new circumstances in the Eurocollaborator project (conceiving, designing and collaboratively modelling a new kind of passenger plane to scale, using aeronautical engineering practices) represented new precedents for the pupils and their teachers. It would be unsurprising if the previous design & technology strategies pupils had learned fell short here because of such factors. A further complication arose from the nature of plane manufacturing as now practised in industry. It is now untenable for plane builders to work alone on their planes; instead they practise the sharing of work on parts of assemblies, supported by distributed engineering approaches. The transfer of this idea to the project meant that the overall definition of the product (in this case a plane) was not subject to the more usual preceded design and manufacturing expectations of teachers (because planes are developed and built from multiple factory locations by multiple teams whose success depended on adherence to a collectively defined product). This situation could allow development of new practices, theories and beliefs where the individual design & technology capability previously practised by pupils and teachers would be challenged where the product (the plane) was collectively defined for the pupils in the different schools building it. Design & technology learning would need to be less based on personal capability and would instead need a (different) more collective capability, one where progress of the project (plane-building) was collectively understood and managed by teachers and pupils responsible for the success of each plane.

## Transformation and Pedagogy

The hoped-for transformation in Eurocollaborator could therefore be summarised as an opportunity for truing of pedagogical thinking in relation to such new precedents, ones which needed altered practices, where it had been previously sufficient to rely mainly on individual design & technology capability but now needed new capabilities based on industrial manufacturing approaches. The Eurocollaborator case study was designed to present new experiences and challenges to pupils and teachers. New capabilities would be learned from the Eurocollaborator project, ones related to corporate plane building methods. The learning of a new kind of collective design & technology capability challenged the more usual preceded pedagogical basis of design & technology capability, because of the 'inter' and 'intra'-school working between different pupil teams, their teachers, the engineers and the new practices across geographical distance between schools. The distances involved were determined by geographical location of the plane-building schools, a precedent being that design and manufacturing decisions for the product (a plane) could no longer be taken on an individual person or even on an individual school basis. Instead these decisions had to be made on the basis of a shared responsibility by the consortium of schools that had responsibility for building a particular plane.

This situation presented pupils and teachers with the new need for a more distributed approach and engagement in design & technology, one where new precedents would be experienced by teachers and pupils, and where transformations of learning and an opportunity for teachers to develop and practice pedagogical change were possible.

In the interests of contextualising these alternative conceptualisations of the design & technology subject, BAE SYSTEMS contributed certain industry knowledge and practice to the design of the project and provided project management skills to help teachers and pupils in the schools throughout the project period. This role can also be described as stimulating a mediated effect on design & technology subject knowledge, for example by bringing an industrial manufacturing context to a transformation.

These stated intentions for the Eurocollaborator project can be considered as helping to provide settings (Leach and Moon 1999) for pedagogy change. Later, in chapter 4, I will develop meaning for these settings through certain distinctions within teachers'



spoken ideas, as evidenced in the taped interviews with teachers, engineers and pupils. The distinctions helped in the development of NVivo categories, for example ways teachers spoke of conserving prior approaches, reforming them or indeed transforming them during the project. These three ideas; conservation, reformation and transformation; are overlaid on the map of research ideas, fig. 3, and will be developed in more detail in chapters 4 and 5 of the thesis.

### **2.3.1 An overview of the evolution of teachers' thinking in design & technology, up to the time of the project.**

The significance of teachers' existing knowledge base in design & technology is being examined during the remainder of this chapter, as well as ways this knowledge base developed and how it could be challenged by alternative conceptualisations in the Eurocollaborator project.

In the teaching of design & technology in UK schools, the relationship between acquiring subject matter knowledge, teaching it and the subsequent learning of pupils was being developed along lines of personal creativity, rather than industrial manufacturing, from the mid last century. This represented a break away from prior and more formal traditions of craft and technical education. The complex processes by which teachers' practice was said to be assembled and adapted to new contexts (Calderhead 1987), can also be partly described as evolving out of a particular historical pedagogical context during the late 1960s and 1970s for design & technology, which is examined next.

Design and technology as a school subject had been shaped by thinking on what pupils' creative experiences should be and by the perceived nature of technological change in society. By the mid 1970s, the time when microcomputers first began to appear in schools, design & technology as a subject did not exist, while art, craft and design education did. Since the 1944 Education Act, attention had been focused on a perceived transformation in the social and cultural background of peoples' lives, rather than on technology per se (Schools Council 1974, 19), and this began to influence certain established traditions in schooling. In broad terms the Schools Council approach to preparing children for this social transformation was founded on

## Transformation and Pedagogy

a general commitment to an individual emphasis on learning, or on understanding rather than memorising, and on enquiry-based work.

There were other pressures for reform, such as the shortage of qualified engineers, blamed on insufficient emphasis given in schooling to the applied or practical arts (Keith-Lucas 1980). In response to a committee of enquiry into British engineering, the Finniston Report (H.M.S.O.1979), recommended the need to articulate a clearer rationale for why an industrial society needed designers and why their education should start in the secondary schools. The Design Council developed Finniston's recommendations via a series of reports about the then perceived lack of design education in schools (Design Council 1980), and dealing with what it saw as a prime factor in the country's future, advocating a total approach to practical education in secondary schools.

This total approach led to a new subject called design & technology, and informed the training of teachers where the importance of project work, with its essential design/ make/ evaluate component, helped to define a new form of personal designing and making for the student (Keith-Lucas 1980). While the importance of industrial design and manufacturing as being key to UK economic well being was recognised, the pedagogical emphasis was being interpreted as a broad based approach to pupils creating artefacts to meet design needs rather than as industrial manufacturing. The individual student would take responsibility for the identification and development of design needs through a personally experienced and developed realisation and evaluation process and the crafting of materials. These ideas built upon previous research (Keel University 1968-73, Loughborough College of Education 1967-72, Goldsmith's College 1969-72, Royal College of Art 1973-76), and earlier pioneering work on creativity (Eggleston 1974, 1975).

Design & technology subject knowledge was becoming articulated along lines where the individual needs of pupils and the unique requirements of different design problems dominated (Eggleston 1974, 63 and 1975, Schools Council 1969, 13-14, Aylward 1975, 16). These ideas have been described a giant leap for the new design & technology subject, a leap away from single minded focus on making skills in post-war teaching, toward one empowering pupils to originate and pursue their own

## Transformation and Pedagogy

designing /making tasks, so helping to establish a new pedagogic issue for teachers (Kimbell 2006).

However, by the time of the 1995 National Curriculum Order (DfES), there was concern that the industrial context of manufacturing was being underemphasised. The now revised design & technology subject instead required teachers to teach a range of industrial applications for a variety of familiar materials and processes alongside the prevailing emphasis on hand crafting of individually made products by pupils in school in pursuit of pupils' creative needs (DfES 1995).

The Eurocollaborator case study therefore appeared at a time when a change of pedagogic emphasis was being directed nationally, yet was not of usual preceded pedagogical form in teachers' subject knowledge. The project would serve as a vehicle to introduce approaches where such knowledge might develop through an aerospace industry emphasis on integrity and visibility of data, an idea that would be helped by electronic definition using computers during the project. The new kind of work-sharing approach involved in the project would instead be informed by ways BAE SYSTEMS' European plane building consortia had evolved to manufacture and bring together large and complex aircraft assemblies from different contributing manufacturing teams based in different countries. Similar approaches would be applied to the ways consortia of Eurocollaborator project schools would share the work of designing and constructing their planes over the two-year life of the project.

To summarise these ideas, I am saying that around the time of the Eurocollaborator case study, design & technology teachers' thinking was described as a single mindedness (Kimble 2002) toward the design process, rather than a single mindedness for an evolved manufacturing in schools, one necessarily drawing from contemporary industrial ideas and thinking (although I am not saying that the design process being taught was unrelated to this). I am also describing this as a pedagogical bias or single-mindedness (ibid) in terms of the deeper understanding of design & technology topics, basic concepts, principles, and themes that could link knowledge structures or conceptual schemas (Shulman 1986). In describing how teachers' knowledge of the subject was generally organised prior to the case study, it can be said that the evolution of design & technology subject knowledge at the time of the

Eurocollaborator project did not represent modern manufacturing. The transformation intended by the Eurocollaborator case study was an opportunity to examine ways teachers' pedagogy might be influenced by a case study experience requiring alternative overarching schema to those with which they were perhaps more familiar. Any changes to pedagogy could also be said to reflect challenges to a fundamental precept of design & technology by the project, one where the sufficiency of a single-mindedness toward personal designing and making was being questioned. These new demands would require design and manufacturing consistency, rather than a prevailing emphasis on personal creativity, to be observed by participants for the plane parts to fit together, a responsibility which would be developed as a project-given by the teachers and engineers who worked with each group of pupils. This situation also represented an opportunity for a truing of design & technology subject knowledge with industrial manufacturing knowledge, one that could be observed and examined through the analysis of data from the case study.

### **2.3.2 The introduction of microcomputers to design & technology teaching in secondary schools.**

I am arguing that pedagogic thinking in design & technology had led it not to represent modern manufacturing, and that this idea can also be contextualised in ways computers were introduced and used in schools. The early introduction of microcomputers to school design & technology in the 1980s can also be compared with introductions of computers in manufacturing industry and business, ones where different goals to teaching and learning had prevailed (Ritz et al. 1990, Hirschorn 1984, Hayward and Bessant 1986, Barclay and Lunt 1985). If it is true that introducing computers into industrial manufacturing implied new representations of design & technology subject knowledge would be needed of teachers, it is also possible to describe this as a mediated influence (Giroux, in Darder et al. 2003) on the school subject of design & technology, one where a further brief historical treatment is relevant to my argument.

While the early beginnings of the new design & technology subject in the 1960s and 70s were largely computer-free, by the mid 1980s the computer began to be introduced to its teaching. By the late 1990s a clearer rationale to reflect current

## Transformation and Pedagogy

practice in industry was thought to be needed. But there were difficulties in using industry approaches in schools (DATA 1999). While some of the new design and technologies of industry, such as Computer Aided Design and Computer Aided Manufacture (CAD/CAM), had gradually become available for use in school, design & technology teachers still experienced difficulties in representing industrial practice in their classroom practices. Some of these difficulties were thought to be pedagogical ones (ibid).

A realistic reflection of such practice in the industrial manufacturing world would need to help pupils recognise that traditional manufacturing and its forms of employment were being rapidly re-shaped by technological change. For example, the punched card/tape Numerical Control (NC) system of the UK textiles industry had been giving way to a Computerised Numerical form of Control (CNC) within an expanding and highly competitive global textiles industry. The computerised control in textiles machinery had largely replaced the old mechanical Jacquard-style looms; the machinery for manufacturing textiles could instead be directed by a code of letters and other symbols via a computerised program of instructions (DATA 1999). While it was clear that computerisation of traditional working practices had altered not only the ways goods were manufactured, but also how they came to be sourced from a global marketplace, it was less clear how this could be introduced to design & technology teaching.

Another reason for difficulty concerned the kinds of computers and software that were available in schools at that time, the prevailing emphasis on personal designing and making therefore remained largely unaffected by the industry role of the computer and the innovations of CNC tooling and machinery. For one thing, the G-code format of CNC was written by, and for, experienced engineers. Using such machines in the school situation was impractical for teaching and was perceived as ‘in the way’ of using the machine as a tool for design (DATA 1999, 9).

There were other attempts to address this problem of a newly required design & technology knowledge (Royal College of Art Schools Technology Project 1996), and attempts to reconcile the industrial manufacturing context with school design & technology. A difficulty was that industrial production tended not to allow the same

## Transformation and Pedagogy

individual freedoms as design & technology; instead the computer had become central in helping to eliminate variations in design and production, which was a different idea to the more usually pedagogically preceded one of personal designing and making.

In industrial manufacturing, ways computers were becoming described as belonging to a new higher level in a manufacturing evolutionary cycle (Ritz et al. 1990), could suggest that their school use was in the context of a lower level in school for household or handcraft approaches to designing and making (Appendix 13). This idea suggests a pedagogical difficulty for teachers in representing modern manufacturing existed.

The origins of this pedagogical difficulty can be traced to change during the late last century, one described in terms of critical pedagogy, or an influence being mediated (Giroux, in Darder et al. 2003), in this case from the phenomenon of the introduction of computers in wider society and manufacturing industry on design & technology subject knowledge.

School design & technology needed to reflect ways the twentieth century had seen the growth of mass-production and mass consumption, change that had resulted from the growth of mass-markets and due to an increasing population, greater affluence and the development of new production technologies. Efforts to reform subject content and pedagogy (RCA Project 1996), also reflected difficulties teachers had in representing industrial manufacturing through school design & technology subject knowledge. In the context of introducing computers into schools, this complexity also existed within non-education research and writings on industrial manufacturing and this too is relevant to the difficulty for teachers of arriving at new pedagogical knowledge for computer use.

Two related views of this can be considered here, the first was a more general view of what had to be mediated. Ritz et al. (1990), described historical development of production systems in the US as a kind of linear progression which had moved originally from household methods, where materials structures and manufacturing goals were produced within the confines of the home and consumed by the immediate

## Transformation and Pedagogy

family, through an evolutionary cycle of handicraft, factory, automated and cybernetic systems which were increasingly controlled by computers.

A pedagogical difficulty was that, for design & technology to develop from the evolutionary cycle of the household or handicraft styles of production commonly used in school, teachers would need to make new kinds of design & technology subject representations for their pupils. But while this first kind of view conceptualised the impact of computers on manufacturing in terms of how products were produced, it offered little on representing how people actually undertook manufacturing that could be used in the Eurocollaborator case study. In fact research into the new work roles and relationships between people in manufacturing, resulting from the introduction of computers, was available (Hirshhorn 1984, Hayward and Bessant 1986, Barclay and Lunt 1985), but provided little to support new design & technology pedagogy, or was of a dystopian character (Shaiken 1985).

More usable ideas for introducing manufacturing contexts to the Eurocollaborator project were eventually developed from a description of the computer's role in BAE SYSTEM'S aeronautical manufacturing (Broughton et al 1995), one consistent with ways the company had further developed the relationship between computerisation, productivity gains and new work practices in terms of a new approach to Electronic Product Definition (Appendix 8) by the time of the Eurocollaborator project.

This approach was chosen to help model industrial manufacturing in the Eurocollaborator project and case study, as a way of representing BAE SYSTEMS' own approach plane production. This would mean that new design & technology subject representations, ones where project participants in the different schools would need to work together on collaboratively conceived and managed projects, would require pupils and teachers to use ICT with an aerospace industry emphasis on integrity and visibility of data, where the parts were defined by computer throughout the project. These time-to-market approaches (ibid) were adapted to encourage the development of new pedagogical precedents during the project, for example when compared with design and make approaches that were more familiar to pupils and teachers in the schools. Evidence of any pedagogies adopted by teachers during the case study in response to new precedents, would form the main focus of the research.

## **2.4 CONCLUDING IDEAS**

A variety of research into teachers' thinking has been examined in this chapter. This has described what others have said about the origins and nature of teachers' classroom thoughts, actions, beliefs and knowledge. Varied ideas and writings of others have been considered to help describe pedagogical intentions behind the Eurocollaborator project, to prepare for the further analysis of precedence, as well as to elaborate and refine this idea and its relationship with transformation. In this context, certain transformations were designed to be presented within the case study to provide an alternative or challenge to the personal designing and making single mindedness (Kimble 2006), or more usually preceded design & technology subject teaching. This situation had the potential to challenge design and technology teachers' existing pedagogical positions and to bring about new pedagogic wisdom. Any evidence found of such pedagogical advance will be examined more closely in chapters 4 and 5 during the analysis of case study data.

Hereafter the ideas developed in this chapter to contribute new ideas to thinking on transformation and teachers' pedagogy, are drawn together and will be referred to as practices, theories and beliefs of the teachers involved in the case study.

## **3. THE LITERATURE REVIEW**

This literature review will examine a variety of sources that bear more specifically on pedagogy in relation to teaching and learning with ICT in schools, so contributing ideas that can help address my overarching research question 'how can ICT facilitate the transformation of pedagogy?'

In chapter 1, the research issues map (fig. 1) identified three sub-questions which reside within my over all research question (01), and were illustrated on the three sides of a triangle:



## Transformation and Pedagogy

The L1 sub-question deals with ‘how can ICT transform pedagogy?’ questions arising in the research, for example where new pedagogical precedents might challenge teachers’ prior thinking.

The L2 sub-question deals with ‘how ICT can change pedagogy?’ questions arising in the research. My overriding concern here will be to differentiate between transformational and non-transformational changes. As such I intend to use this sub-question to help eliminate non-transformation from my research focus.

The L3 sub-question deals with ‘what is meant by pedagogical transformation?’ questions. Certain ideas have already put forward in chapter 2 concerning this sub-question, for example those dealing with precedence and teachers’ thinking and in the idea of the Eurocollaborator project where there was a focus on the difficulty of representing modern manufacturing within design & technology teaching. Addressing this sub-question will be a particular focus of the present chapter, especially in terms of what other research and writings may be able to contribute.

This chapter therefore examines how the available literature on ICT, pedagogy and transformation may inform an understanding of pedagogy change in relation to computers, teaching and learning.

### **3.1 TRANSFORMATION OF PEDAGOGY FACILITATED BY ICT : A HISTORICAL PERSPECTIVE**

The Eurocollaborator project had set out to create pedagogical precedents. ICT would be used in particular ways in a school and industry design & technology context, and described as transformation.

These ideas of transformational pedagogical precedence will be developed in the context of the literature reviewed in this chapter. The design & technology situated context of transformation and pedagogy examined in my case study locates it within the wider perspective of ICT in education. I will also consider the idea that traditional educational approaches miss opportunities. Therefore, an understanding of how ICT

can support the transformation of education, so that it makes use of pedagogies appropriate to the 21<sup>st</sup> century, is needed (Becta 2006, 51).

### **3.1.1 Positioning transformation and pedagogy in a historical context.**

While national strategy in the UK has adopted the idea of ICT as a vehicle of transformation of education (Becta 2006), I will argue that the vehicle has evolved to represent ideas, which may not have been present in the earlier period of introducing computers to schools. For this reason this chapter begins by exploring these earlier introductions, from the early 1970s to the late 1980s, when affordable microcomputers first appeared. It will be argued that this earlier period was one of experimentation, but that this focus changed during the interim and later years. After the earlier period, other priorities and expectations of computer-related investment in schools were developed. This phenomenon, one also noticed by others (Watkins and Mortimore 1999, 13), has made the problem of evaluating the ICT's potential to enhance learning, and the success of the investment, more complex.

The issues surrounding computer use in schools today may be less clear-cut now than they were during the earlier period, reflected in the concerns and lines of enquiry in literature on the subject. To explore this idea, a cross-section of literature from the early 1980s to the late 1990s will be examined. A focus on the earlier writings will examine if indeed there was an initial emphasis on experimentation and new approaches for their own sake, one perhaps more open to transformation as defined here, only to be gradually replaced with other concerns and priorities over time.

This interpretation of pedagogy with ICT needs to examine what it was that early researchers in this field thought to be important about computers in schools and whether this was transformation that they had in mind.

### **3.1.2 The introduction of computers to UK schools.**

Writings from the early period of the introduction of computers to schools reveal both the limited expectations of computers, perhaps due to their high cost and relative scarcity still to schools, as well as policy thinking toward their relevance and use in

## Transformation and Pedagogy

schooling. For example the former Inner London Education Authority reported that only a few local education authorities had initially supported the idea of obtaining microcomputers for school use and that it was the UK government's decision in 1982 to give a 50% subsidy towards a computer in every secondary school, that stimulated a change of view here (Easterton 1982, 134-148). While UK introduction of microcomputers seems to have been initially regarded circumspectly, for example with concern for a burden superimposed on schools, the need for teachers to develop new skills was also being recognised as an aspect of the integration of information technology into most areas of the curriculum and the then newly launched certificate of pre-vocational education (ibid).

An increasing complexity of challenge presented to schools by such integration, on a scale perhaps unanticipated in the earlier period, can be said to remain to this day. For example, a recent statement of issues schools now face mentions:

- Managing increasingly complex and developing teaching/learning and technologies.
- Sustaining existing teaching/learning investment.
- Realising the benefits from, and successfully embedding ICT into teaching, learning and institutional improvement.
- Awareness of unacceptably large and increasing inequality of access, and the gap between the best and the worst pedagogical practice in the use of ICT.
- Achieving less than optimum value for money due to the disaggregated approach (by schools) to ICT procurement.

(Becta June 2006, 13)

Such contrasts, between earlier and later thinking on introducing computers, suggest that a historical context would be useful in helping to more clearly articulate ideas on transformation and pedagogy. Examining the history of the introduction of computers might bring more understanding on:

## Transformation and Pedagogy

- Whether the early ideas were genuinely transformational, as transformation is interpreted in this thesis, and whether they led early educators to re-think learning, as was being urged during the early 1980s (Papert 1980).
- Whether the early introductions of computers into schools were motivated by rethinking learning, or equated more to the old issues in the new clothes of ICT.

The point of my comparison between early and later thinking on introducing computers is also to suggest that since the early period there has been a continuation rather than a resolution of pedagogy precedence arising from ICT and computers in school. This idea is relevant to my research sub-question L3, through suggesting deeper reasons for what seems to be an on-going difficulty with ICT and pedagogy.

Papert's (1980) early arguments were developed when computers were still rare in schools. His idea that computers meant re-thinking learning may have been influential in principle. But the increasing availability of computers in schools since that time seems not, in itself, to have diminished the need for teachers to adopt new pedagogies in relation to ICT. This fact needs to be borne in mind before assumptions about transformation of education by ICT are made.

These issues will be examined and a framework will be presented for literature in the context of transformation and pedagogy over the last 30 years.

### **3.1.3 A broad description of the intervening years of learning with ICT in schools.**

It can be argued that Papert's (1980) ideas were very influential during the early period of introducing computers, an idea that will be further examined in this chapter. Papert also collaborated with Piaget during the 1960s and there are certain similarities in their ideas on how children become thinkers. Piaget originally trained in the areas of biology and philosophy and considered himself a genetic epistemologist (Piaget 1972, cited by Huitt, & Hummel 2003, 1-5). He was mainly interested in the biological influences on how we come to know, and believed that what distinguished

## Transformation and Pedagogy

human beings from other animals was our capacity for abstract reasoning (ibid). Piaget had described two processes used by the individual in its attempt to adapt: assimilation and accommodation, both being used throughout life as a person adapts to the environment in a more complex manner. Assimilation is the process of using or transforming the environment so that it can be placed in pre-existing cognitive structures. Accommodation is the process of changing cognitive structures in order to accept something from the environment (Piaget 1972).

In a direct development of Piaget's ideas, Papert (1980) theorised that the computer could concretize (and personalise) the formal, giving enhanced or improved access to knowledge that children need in order to become formal thinkers (in the Piagetian sense). As well as the underlying Piagetian cognitive theory, Papert's thinking was linked to a view of instructional design. The thinking had been used to help develop design criteria for Turtle geometry, an early innovative computer controlled classroom product, and in articulating the rationale for its introduction to learning mathematics. A precedence in Papert's thinking at that time was articulated in terms of new ways pupils could perform maths operations, and ways the expanded mathematical constructs provided by LOGO would free them to think and develop higher levels of mathematical understanding (Papert 1980, 120-156).

Viewed from the perspective of my research questions, Papert's (1980) ideas do seem to imply that teachers would need new pedagogical precedents, however they do not fully articulate what this will mean in terms of pedagogical change. Rather they simply suggest that we no longer need the more usual pedagogical precedents that teachers use in representing knowledge, or that the computer can instead provide a wide alternative range of mathematical constructs.

Others around this time were commenting on ways computers would be used in schools, despite the limited funding then available for them (Easterton 1985). The early idea of access to information technology developed, for example Hoyles and Sutherland (1987, 67-80) argued that quite how they would be used was not obvious at that time, and observed that on average there were about 13 microcomputers in each secondary school and 1 or 2 microcomputers in each primary school. They also

## Transformation and Pedagogy

noted disparities in terms of hardware provision; London for example had introduced twenty 16-bit machines in selected primary schools in May 1986.

In fact, since Papert's early (1980) exhortations that computers should alter learning, there had been a steady flow of articles appearing in such as the *Journal of Computer Assisted Learning* and other periodicals reporting research into the usefulness of programming and what using LOGO might bring to learning, especially in the subject of mathematics (Hoyles 1985, Hoyles et al. 1985, 68-73, Smith 1986, 102-109, Noss 1987, 2-12, Goodyear 1987, 214-223). These early writings can be said to have articulated an educational concept of programming for classroom computers, while early pedagogy discussion considered the possible value of computer programming to pupils' learning.

If Papert's early ideas were genuinely transformational, as defined in the terms of this thesis, it must be asked what new precedents were brought to practices, theories and beliefs and stimulated by the uses of logo by pupils in school? To what extent did these changes warrant pedagogical change and how (if at all) was this then described?

The then new LOGO educational product introduced the idea of the microcomputer as a teaching machine, having been developed at the Massachusetts Institute of Technology in the late 1960s. Papert's collaboration with Piaget seems to have led to his design-rationale for LOGO, alongside his vision for what computers could do for learning, focussing on children, the nature of thinking and how children become thinkers. LOGO was a new product, one introducing a new programming language to teachers and pupils in schools. This was intended to facilitate learners in selecting their own problems. Hence, the suggestion was that a learning-focused programming language could contribute to the fundamental mental processes of learners, even when they were not physically engaged with a computer (Papert 1993). This was also a challenge to (then) beliefs about who can understand what and at what age, challenging standard assumptions in development psychology and in the psychology of aptitudes and attitudes.

In presenting Papert's (1993) argument for the process of constructing computational structures, his ideas deal with a number of precedents. For example, one precedent

## Transformation and Pedagogy

might be greatly increased capacity for self-directed (rather than teacher-directed) learning. A second might be enhanced knowledge generally, rather than just of mathematics knowledge. A third might be that the (then) new computer use and LOGO could help children to accelerate their learning in ways that might not previously have been expected. Pedagogy rationale is conspicuously absent from these original writings, although there was certainly a growing debate from the classroom by some trying such ideas in the earlier period (Goodyear 1987, Hoyles and Sutherland 1987).

Even so the case for transformation of learning via LOGO had to be defended, as was the idea that doing LOGO or working with computers would cause change in how children think. Rather, LOGO came to be defended as a medium for the creation of learning environments, ones where different pupils would react individually (Papert 1993).

This idea of transformation was where all children would, under the right conditions, acquire proficiency with programming that would make it one of their more advanced intellectual accomplishments. This was also a vision of the benefits of the child programming the computer to learn, rather than the reverse, as well as one within a vision of computers becoming plentiful in schools.

Unsurprisingly perhaps, not everyone agreed with these ideas. By 1983 claims for programming as an educationally beneficial activity were still controversial. Although there were supporters, there were still difficulties faced by pupils, as novice programmers, which had to be overcome by the acquisition of (potentially) generalisable programming knowledge or cognitive skills. For example:

1. The thorough acquisition of a knowledge base allowing program constructions to be 100% semantically and syntactically accurate.
2. The acquisition of certain problem solving strategies vital to successful program construction.
3. The maintenance of an attitude of persistence toward the problem solving.

(Goodyear 1987, 214-223)

## Transformation and Pedagogy

Although LOGO had been designed as a machine to allow such skills to develop iteratively and as an integral process of LOGO usage by pupils, Goodyear's (1987) difficulties are suggestive of new precedents that LOGO computer programming implied for pedagogy.

For example, the new precedent of pupils learning via high levels of self-directedness through LOGO was initially thought to mean that new practices of programming knowledge and programming problem solving would have to be taught to all pupils. The transferability of the programming skills to other domains was also dependent on level of access to school computers implied by programming for all pupils (Goodyear 1987, 214-220).

Despite such early difficulties, successful LOGO work seems to have developed. The turtle-geometric environment functioned usefully in the classroom and appears repeatedly in the *Journal of Computer Assisted Learning* as well as other journals of the period, where two issues deserve mention:

1. A transferable potential of LOGO learning came to be explored. For example Hoyles and Sutherland (1989) were writing about the potential of LOGO in the secondary school mathematics classroom. Their main focus had been to discover whether and under what conditions the computer language LOGO could be used as an aid to pupils' learning and thinking in mathematics. Research included longitudinal case studies with pairs of pupils for up to five years, together with the idea of peer-collaboration and the role of the teacher in the LOGO environment.
2. Dialogue in the educational community concerning pedagogies and ICT (Hoyles and Sutherland 1987) on how teachers might work with LOGO as a means to identify pupils' alternative conceptions of mathematical ideas. This idea took account of other earlier (non-computer based) research into teachers' thinking, as already mentioned in chapter 2 (Bromme 1987), and developed the idea that teachers could implement computer-based problem situations to confront these pupil misconceptions; or to throw up obstacles that cannot be handled by existing pupil understanding with the aim of encouraging new perspectives.



Hoyles and Sutherland's (1987) work, therefore began to describe early thinking on pedagogy with computers, beyond the narrow confines of mathematics and LOGO where introducing computers began. While the particular changes to learning implied by LOGO and non-LOGO contexts seem to have implied changes to teachers' pedagogy, these had yet to be articulated into a transformation of it. Rather, these changes were seen to affect teacher's social-classroom relations and interactions with pupils, the ways pupils were allowed to choose their own goals, the organisation and management of pupils in the classroom, as well as including the responsibility given to the pupils for this. However, these debates do contribute meanings to my research questions, especially the L1 sub-question 'How can ICT transform pedagogy?' in the context of these precedents arising from the earliest introductions of computers to schools. This seems to have begun in the subject context of mathematics teaching but gradually developed beyond it to other subject teaching.

While the early introduction of LOGO does seem, on balance, to deal with transformation because of the new precedents it implied for pedagogy, it is less clear that a similar case can be made for other introductions of computers to the classroom. For example there was a continuing debate over whether the computer should be used to teach a specialist subject in its own right, such as computer science, or whether it had potential for introducing more generic learning strategies such as problem solving. Early writing had also explored the use of computer simulation to give experience of experimental design and hypothesis testing in science, such as to provide for pupils an alternative means to exercise planning experiments, test hypotheses and interpret results without the technicalities and calculations of science predominating in their minds (Ayscough 1977, 201-213).

However, such debate did not seem to deal with new precedence in science teaching. Pupils were still doing their decision-making but the computer was making scientific insights and testing more accessible by substituting difficult scientific calculation with computer simulations. It could be inferred here that such an approach was not dealing with transformation as such because the preceding states of affairs were unchanged by it or, put another way, simulating existing experiments did not bring new precedents to the teaching and learning as such. This inference would be an interpretation of

## Transformation and Pedagogy

historical literature material though, one bearing upon my L2 sub-question: “How can ICT change pedagogy?” Care in making such an inference is needed, for example it may be that research thinking from the early period was simply undeveloped in its treatment of computers in learning. However this sub-question allows such non-transformation to be eliminated from my research, other than its brief mention as historical context.

On the other hand, Freeman and Tagg’s (1985) article in the first publication of *Journal of Computer Assisted Learning* dealt with the early uses of databases in the classroom for learning geography and history and deserves further mention to make this point. Here, the benefits of data-handling programs, such as QUEST, for learning in geography and history in allowing data to be planned, categorized, stored and interrogated to test hypotheses, were being explored as a transformation into lists, diagrams, statistics or maps, so that new light could be thrown on the data by transforming it and highlighting new aspects of it (ibid, 2-11).

The argument for transformation of learning here could be in terms of certain new challenges, ones where improved information handling through software programs allowed more information to be handled more easily. Freeman and Tagg (1985) can also perhaps be said to have introduced pedagogy precedents though their idea that using computers in geography requiring pupils to use more systematic approaches to problem solving, planning and formal-reasoning. This, at very least, represents an early example of teachers’ thinking about pupils’ learning because of computers, and implies change pedagogy if not transformation as such.

### **3.1.4 Research that does seem to further illuminate my L1 sub-question: ‘How can ICT transform pedagogy?’**

By the mid 1980’s the idea that computer usage might be beneficial to all learning is present. But I have found less writing on how teaching and pedagogy might also need to change to support this idea. While school computing resources became increasingly available, thinking on their role broadened too, such as the role of the microcomputer could have in supporting discussion and tutoring. Typically these concerned the extent the microcomputer could be a quiet catalyst in the learning environment

## Transformation and Pedagogy

(Cummings 1985, 149-159), or on how the computer could contribute significantly to language across the curriculum. Cummings' (1985) research was based on a project with 40 boys and girls from two primary and three secondary classes. It tested the case argued in the Bullock Report (1975), for encouraging small group activity and discussion in place of more teacher-directed classroom interaction. This was an argument for increasing the value of talk and dialogue in moving pupils toward new understanding (Rogers 1980, 180-194). Cummings's (1985, 149-159) research suggested that the microcomputer had a positive influence here, children unfamiliar with CAL in his cases typically stated that the computer was silent and sophisticated and that it didn't talk back. The research conclusions, though cautious, suggested that the computer appeared from this project to be a highly influential factor in kindling group discussions of an influential nature.

The strength of argument for Cumming's position grows from the microcomputer being able to provide a productive medium for enquiry learning, especially if it enables children to turn the tables (on teacher) and become more accustomed to asking questions rather than answering them and to be less inhibited in thinking out loud. Cummings hints at transformation of pedagogy because he describes certain new contexts or practices needed for motivating group work by children. For example, he stresses the shift from teacher being more manager than mentor in this process and observes that responsibilities are increased not diminished. By this is meant that teachers can spend less time on direct communication with children and more on encouraging language as a thinking tool and encourager of meaning.

The idea of intelligent computer assisted learning through 'intelligent tutoring systems' and 'guided discovery learning' systems built around machine learning programs (Self 1985, 159-166, O'Shea and Self 1983, 127-172, 177-215), also developed at this time. This drew upon the then developing area of Computer Aided Learning (CAL) to propose a model of learning with the computer through guided discovery. The significance of this early work is its emphasis on the learner's activities, beliefs and understanding, and also on the learning process itself. The computer was becoming more universally useful as an accessory for interaction.

## Transformation and Pedagogy

From this grew the phenomenon of peer-interaction or collaboration in learning with the microcomputer. The prospect of improved learning as a result of pupils sharing a computer, or working with one in groups, had already been implied by Papert (1987) and explored by Hoyles and Sutherland (1987). Ideas on paired practice, as compared to pupils working individually at the computer, developed (Colbourne and Light 1987, 130-141). There was perhaps a question of whether the computer provided an environment particularly suited to generating effective interaction and whether pupils' social interaction at the computer led to any significant learning gains though.

Colbourne and Light (1987) had difficulty in finding any significant differences in eventual attainment between children exposed to group work, using the computer software micro-PROLOG, and those working individually on computers. They also admitted to difficulty in designing their case studies to hold up under the more naturalistic conditions of the classroom. There is an absence of references in their article to pedagogy change, or ideas bearing directly on my L1 question, although it can be said that pedagogical implications arising from collaborative learning were being implied and became more clearly articulated in later work on collaborative learning examined later in this section (Crook 1987, Dillenbourgh 1996).

### **3.1.5 Some interim conclusions on the research sub-questions.**

The early introductions of computers so far described suggest there was a developing tension between two ideas:

1. Some of the early thinking involving the introduction of computers has been shown as informing my L1 question. ICT was thought to transform, or bring new precedents to learning, for example where pupils' programming of computers might facilitate or transcend certain cognitive stages, which would otherwise have limited learning (Papert 1980). Pedagogy is mentioned less than learning, although change to teaching is implied. Piaget's predominantly individualistic perspective on cognitive development was questioned, leading to greater interest in the computer's contribution to social processes and ways this might develop cognitive progress (Colbourne and Light, 1987, 130).

2. The general idea that availability of more hardware would open the way to greater progress in schooling, for example in generic learning or educational computing, had more bearing on my L2 question and can therefore be largely eliminated as non-transformation from my research.

Colbourne and Light's (1987) materials also reveal overly ambitious expectations of researchers from quite limited case studies of the time, together with the difficulty in understanding how to approach complex phenomena with overly simple or underpowered research tools and the primitive state of the classroom computer at that time. This research, relying as it did on interventions where pupils were removed from classrooms to sit at computers doing test activities for comparisons of dubious context and relevance, perhaps also reflects early assumptions about inherent and observable benefits of computer use by pupils.

A gradual acceptance for the computer as an aid to teaching and learning in schools led to interest in approaches that would help teachers to teach with them, or to manage them within the local conditions for learning (Katterns and Haigh 1986, 162-171). These suggest a more general debate about criteria for teacher effectiveness with the computer, together with concern that the computer might be thought to be taking over the teaching: "In our view, computers should have a continuing place in school classrooms- but not because computers and their software are a viable substitute for the teacher. We do not believe that either teachers or computers have power to bring about learning directly" (Katterns & Haigh 1986, 163). This effectiveness debate allowed a sharper focus on pedagogy, albeit from a rather threatened perspective. Katterns and Haigh's (1986) argument was consistent with ideas being developed on teachers' thinking at that time, and anticipates later thinking on pedagogy settings (Leach and Moon 1999). This line of argument was more fully developed later where the case for more directed approaches to teaching was giving way to the idea of teacher as facilitator (Katterns and Haigh 1986, de Jong et al. 1998, 235-246, de Jong and van der Hulst 2002, 219-231, Kramaski and Hirsch 2003, 35-45, Salovaara 2005, 39-52). In this argument then, the computer is seen as one of a variety of conditions to be arranged, or as tools which teachers may use to influence learning conditions, with the intention of facilitating learning.

## Transformation and Pedagogy

Between 1980 and 1985 the introduction of computers to schools increased dramatically (Jackson et al. 1986, 45-55). A survey of all English Local education authorities (Jones 1980, cited by Jackson et al. 1986), discovered only 30 primary schools using microcomputers yet, by 1984, three quarters of primary schools nationally had acquired at least one (BBC/MEP 1984). It was also noted at the time that this rapid acquisition of hardware had not been supported by adequate research (Jackson et al. 1986), while in considering the motivation for these introductions it was noted that:

1. The majority of the schools had been using a single microcomputer for a year or less.
2. In general microcomputers were used with groups of two or three.
3. The most frequently used software was mathematical drill and practice.
4. The most frequently expressed aims were to reinforce school work and to prepare pupils for later life.
5. The main advantages of computer use was reinforcement of and motivation for school work, and the ensuing familiarity with computers.
6. Future needs identified were for better software and greater access to training courses and advisory services.

On the other hand, Jackson, Fletcher and Messer's (1985, 54) argument was for drawing teachers away from drill and toward child-centred programs, paying more attention to training and provision. Their advice suggests that early interest in the introduction of computers as transformation, a bearing on my L1 question, had developed into a more routine expectation of the computer, having more possible bearing on my L2 research sub-question.

### **3.1.6 A summary of ways research and the writings of others have bearing upon my L1 research question, "How can ICT transform pedagogy?"**

There is clear evidence of transformational thinking during this early period, even though transformational language is not necessarily present. The early evidence found is summarised here as an evolutionary portrait of transformation from the period when computers were first introduced:

Fig. 4: an evolutionary portrait of transformation.

<p><b>Precedents of transformation</b> (New or un-preceded contexts or conditions that required changed response)</p>	<p><b>Transformation phenomena</b> (New contexts or precedents from which new pedagogical processes were developing)</p>
<p>Children ‘programming’ as an advanced intellectual accomplishment (Papert 1980, 1987).</p>	<ul style="list-style-type: none"> <li>• Freer access to computers.</li> <li>• New computer languages.</li> <li>• New learning environment around the computer language.</li> </ul>
<p>Extension of learning from (LOGO) programming to non-programming contexts (Hoyles and Sutherland 1987).</p>	<ul style="list-style-type: none"> <li>• Changed teaching practices.</li> <li>• Changed classroom relationships.</li> <li>• Pupil autonomy in choosing goals.</li> <li>• New responsibilities given to pupils.</li> </ul>
<p>Using database tools to allow children to understand patterns and relationships within data (Freeman and Tagg 1985).</p>	<ul style="list-style-type: none"> <li>• Pre-structuring of information for the computer.</li> <li>• Systematic approach to problem solving.</li> <li>• Pre-planning.</li> </ul>
<p>Group work and collaborative learning with computers (Cummings 1985).</p>	<ul style="list-style-type: none"> <li>• Teacher becomes manager.</li> <li>• Increased encouragement of thinking, less emphasis on telling.</li> <li>• Less direct communication.</li> <li>• More emphasis on eliciting meaning via pupils’ thinking</li> </ul>

	and thinking skills.
--	----------------------

**Fig. 4, source: author**

Some limitations of my proposed evolutionary summary, fig. 4, need to be mentioned. The early historical inferences do begin to illuminate the research questions in this thesis. It could be broadly stated that during this early period new contexts or precedents of transformation began to appear and were leading to the development of new practices, theories and beliefs in the sense of a transformed pedagogy being described in this thesis.

The three research sub-question in the thesis can be revisited to qualify this idea:

In dealing with the L2 sub-question, ‘how ICT can change pedagogy?’ the earliest evidence suggests computers began to be introduced to schools in limited numbers and for more limited purposes, such as to teach programming, but that these purposes were then extended to other contexts through processes of research, experimentation and discovery (Hoyles and Sutherland 1987). An implication here is that this discovering included changes to teachers' pedagogy that seemed beneficial to the learning with computers, but not necessarily transformation of pedagogy.

In providing inferences to the L1 question, ‘how can ICT transform pedagogy?’, evidence from this early period suggested that using computers in school led to a realisation that earlier methods of teaching no longer suited, or at least as well as they did before computers were used. Some (Papert 1985), expressed radical views on the worth of this teaching, while need for development of actual pedagogical change seems to have grown more gradually as a consequence of experience of teaching with computers. This growing need can be observed in the development of new styles of learning, such as in the debate on value of collaborative learning with computers (Cummings 1985, 149-159). However I have found little material describing the nature of pedagogical change in this.

In providing inferences to the L3 question ‘what is meant by pedagogical transformation?’, it is argued in this thesis that a modest change to pedagogy can



hardly justify the description of transformation. The emphasis with some of the earliest introductions of computers seemed to deal mainly with more modest ideas for what the computers could bring to existing learning, such as general reinforcement of and motivation for school work, or the ensuing familiarity with computers aligned with my L2 sub-question (Jackson et al. 1985), without necessarily a transformed pedagogy. There were exceptions where pedagogy was given attention, for example with the role of the teacher in the LOGO environment (Hoyles and Sutherland 1987, 71-73), while the radical ideas of Papert at this time might be described as promoting a transformation of learning, rather than a transformation of pedagogy, where computers could mediate childrens' learning.

While the nature of pedagogy transformation was not very explicitly dealt with in this early historical material, the conditions for later pedagogical difficulties with computers and ICT can be perhaps described as an indifference to my L3 question.

In the early period therefore there was still an unclear understanding or of the ways new pedagogical practices, theories, and beliefs could be transformed by computers.

### **3.2 RESEARCH IDEAS FROM THE LATER 20<sup>TH</sup> CENTURY PERIOD**

It will be useful to compare my ideas on the early introductions of computers with a cross sections of materials from a later period. During the closing years of the last century, writings on the usefulness of computers in schools were by then telling a different story. This idea can be examined by comparing writings about continued uses of LOGO software (Hoyles and Sutherland 1989, 208-222, Hoyles et al. 1994, 202-215, Yelland 1994, 33, Kapa 1999, 73-84, Subhi 1999, 98-108). Examining this is useful in helping to articulate shifts in thinking about learning and pedagogy during the later period.

For example, computers were introduced for the purpose of social integration. Kapa (1999) wrote of the development of LOGO in Israeli Schools where forty 10 to 11 year old pupils in the Tel-Aviv metropolitan area were using co-operative learning approaches: "The opportunity to construct mathematical concepts in ways that enhance cognition through problem solving comes from the immediate feedback that

LOGO Turtle provides.” (Kapa 1999, 76) Two kinds of planning had been developed from Papert’s original (1980) ideas, top down planning in which pupils get the idea and the structure of the solution first and then begin to carry out the plan, and bottom up planning in which pupils build their plan step-by-step from details to the general scheme. Kapa was developing Hoyles and Sutherland’s (1987) ideas on LOGO, but in the context of learning in Israeli society where sharing and learning in pairs was deeply ingrained in Jewish tradition. It was this cooperative development of LOGO that was now extending the potential of LOGO microworlds for their cooperative learning potential (Kapa 1999). The categories for this co-operation were:

1. *Together and apart*: the pupils sit together but they are not really cooperating. Each one of them solves the problem in his or her own way.
2. *One of the pair is working, the other is ‘dreaming’*: in this kind of cooperative interaction the task actually is being done by one of the pair while the other is mostly occupied in things that are irrelevant to the educational task.
3. *One of the pair is working, the other is mostly observing*: both of them are working together but there is a gap between them in the level of contribution to the solution of the problem: one is active and the second is passive most of the time and follows the partner.
4. *Distributed work or parallel work on separate parts of the task*: both are dominant and want to contribute their part to the problem solution. They are aware of each others will, and therefore they decide to divide the work between them. Sometimes distributed work is done for other motives, for example, the need to complete the task in limited time.
5. *One of the pair is dominant*: one of the pair is dominant cognitively and the other finds himself doing mostly routine work because of a wish to participate in the task actively.
6. *Both of them work together*: both of them are busy in the task while searching/receiving information each from the partner. If there are contradictions, they are solved by cognitive negotiation between them.

(Kapa 1999)

It is possible to consider the usefulness of my research sub-questions in relation to Kapa’s categories. For example, did this approach to using computers represent a shift

## Transformation and Pedagogy

in emphasis away from my L1 research sub-question on transformation, or did the emphasis on facilitating co-operative learning in the context of mathematical learning represent an inclination toward my L2 sub-question on how ICT can change pedagogy? If Kapa's (1999) categories of co-operation meant new precedents in teachers' thinking about pupils' social learning, then this research would align more with my research L1 sub-question. However, if this research subsumed LOGO learning within a usual preceded context in Israeli society, one dealing with Israeli social integration, then this would represent a shift away from L1 toward my L2 sub-question, one where well established precedents from non-computer contexts were simply being emphasised or embedded by introducing computers to the classroom instead. ICT could provide some change to pedagogy, such as the ways computers were made newly available in classrooms, but along broadly un-transformational or L2 research sub-question lines.

However, the longevity and popular use in schools of LOGO certainly is demonstrated here, for example by the fact that pedagogical improvement and refinements were still being made in its cause some 19 years after it was first introduced to schools. The writings on LOGO throughout this later period also seem to describe a much longer and drawn out process of change to pedagogy than the idea of transformation might suggest.

The influence on teachers of Papert's original (1980) thinking is supported by other research from the period. (Sparkes 1998, Subhi 1999, 98-108, Lowenthal et al. 1998, 130-139, Jones 2002), and that the desire for certain kinds of transformation suggested by the ideas had become absorbed into more standard practice. However, this is not the same as saying that Papert's original ideas had been fulfilled or that ICT and pedagogy have developed much over the period (Lewis 2002, 1).

The transitional years between the very end of the 20<sup>th</sup> century and the beginning of the 21<sup>st</sup> century were marked by concerns (Gardner et al 1992, 1993), that pedagogy might not be developing as had been at first hoped. The longitudinal study Impact2 (DfES 2001) examined 60 schools in England over a three-year period and set out to provide a perspective on the growth of pedagogy alongside ICT transformation. Findings suggested that many teachers were not confident about using technology in

## Transformation and Pedagogy

their classrooms, training made high demands on personal time and that little IT integration into subject teaching had taken place (ibid, 13). There was a small indication that teachers were starting to consider taking on a new role but classroom approaches were far from being significantly influenced by the use of ICT (DfES 2002, 13). ImpaCT2 also began to identify some perceived obstacles to pedagogy change, for example not having a computer at home, allowance of school time to help familiarisation with software, leadership by example from senior staff, together with mentions of lack of bandwidth and/or slow Internet connectivity and worries about national policy being over-dependent on the so-called National Grid for Learning.

During this period, HMI also began to focus on some of the issues implied by my L2 sub-question, for example in terms of limitations in resources available to teachers: “Too many teachers still lack confidence in using ICT and this is often made worse by a lack of appropriate software, unreliable computers and Internet connections, and insufficient technical support when things go wrong.” (OFSTED 2002, 15). There was also a criticism that ICT tasks were not always related to lessons and were limited by:

- Lack of guidance by teachers.
- Lack of knowledge about when to use and when not to use ICT.
- Lack of teacher skills and confidence.
- Lack of appropriate intervention by teachers.
- Lack of recognition of student expertise in ICT.

However it can also be argued that, by 2004, certain ideas that originally grew from early LOGO use in the (mainly) mathematics classroom had become woven into a broader pedagogy position, one where socio-cultural theory was helping to address certain later issues and concerns (Sutherland et al. 2004). This work addressed a growing anxiety that, despite three decades of government initiatives and academic research, the use of information and communications technology in teaching and learning remained only partly understood by educationalists and inconsistently practised in schools (Goldstein 1997).

## Transformation and Pedagogy

There grew a determination in the UK to develop new and improved theoretical standpoints on how teachers' pedagogies might be expected to change (concerning my L2 sub-question) as well as be transformed (my L1 sub-question). It is arguable that these concerns grew from ideas surrounding early LOGO approaches to mathematics (Hoyles & Sutherland 1987), and how these might be subsequently developed into a more general theoretical standpoint on pedagogy where teams of teachers and researchers tried to develop ways of embedding ICT into everyday classroom practices to enhance learning. The subject focus was on teaching and learning across a range of subjects: English, history, geography, mathematics, modern foreign languages, music and science. The influence of young peoples' out-of-school uses of ICT on in-school learning was also considered. Sutherland's (2004) socio-cultural perspectives on pedagogy change, where creative tensions between idiosyncratic and institutional knowledge construction are emphasised as well as exacerbated by the use of ICT in the classroom, characterise this work (Sutherland et al 2004, 20, 413-415).

More specifically, this work identified a root cause of teachers' lack of ICT pedagogy as lack of interaction between the theory and the practice of teaching, setting out to explore how a closer relationship might be built between them, while repudiating much professional development then associated with ICT as mere transaction rather than transformation (Triggs and John 2004, 426-439). The argument is interesting for my research in that it suggests ICT and professional development process could not be successfully developed along simple transactional lines, or as a mere re-tooling of teachers (in the sense of issues relating to my L2 sub-question) to augment their existing practices with improved skill levels in the uses of ICT. Instead it would be necessary to take account of teachers' deeper professional needs and subject applicability.

More importantly for my L1 research sub-question, this research was describing an attempt to overcome a pedagogy disconnect, one implying that a transformation in classroom culture and professional learning was needed. This argument was developing ideas of social participation for teachers and researchers (Wenger 1999, 55-57) and on knowledge creation and transfer (Triggs and John 2004, 428) where individuals and groups define mutual problems and new knowledge to solve them.

The use of organisational theory to help explain ways teacher knowledge develops, the role of communities and ways pedagogy may be situated, social and distributed (Triggs and John 2004, 430), were used to illustrate the increased complexity and sophistication with which ideas first encountered within the earlier work on LOGO in the 1980s have developed to this point.

### **3.2.1 The mandating of schools during the later period of introducing computers.**

The ways schooling was mandated and organised have possible bearing on the ideas concerning transformation and pedagogy in this thesis. One significant preparatory change for the later period had been the introduction of the National Curriculum by the UK Government in 1987, and the effects of a more regulated curriculum (Watkins and Mortimore 1999, 13-15). For example the revised Programmes of Study for 2000-05 gave a common structure and design across all curriculum subjects and set out the knowledge, skills and understanding to be taught as well as the breadth of study across the key stages. Notes were provided in the margins where there were opportunities for pupils to use information and communications technology as they learn the subject. Because each National Curriculum subject document was accompanied by schemes of work setting out objectives, activities and expected outcomes for each unit, including the use of ICT, this together with the effect of scrutiny via external inspection had led to debate about the encroachment of government and government agencies into the areas of teaching methods and priority to use ICT in schools. The mandating of ICT within subject teaching, including the Teacher Training Agency's (1998) statutory requirements for all newly qualified teachers, may seem to suggest that teachers would become secure in their standards. The various conclusions drawn on teachers' pedagogy by the later period actually suggested the case was otherwise (Webb and Cox 2004, 275, Sutherland et al. 2004, 413, McCormick and Scrimshaw 2001, 37).

More importantly for my research, it seems that the mandating of ICT in the school curriculum may have stimulated interest in the difficulty of describing an ICT pedagogy in the UK. The ensuing process of reviewing the available research and developing certain new constructs to represent pedagogy, should have had bearing on

## Transformation and Pedagogy

the idea of transformation in view of national priorities being developed in this more recent period (Becta 2006).

A more recent review of writing on Pedagogy Related to Information and Communications Technology (Webb and Cox 2004), has attempted to draw the available research material into categories of sources so that its value and relevance to pedagogy can be better understood:

1. Bibliographies.
2. Studies of effective teaching.
3. Short-term interventions associated with software design.
4. Studies associated with the introduction of an additional general resources, such as laptops or the availability of the Internet in science.
5. Studies focussed on specific aspects of pedagogy in specific subjects, involving development work with ICT over the last two to three years.
6. Longitudinal studies involving development and evaluation work over the last five years.

Like others (Bromme 1995, 205-216), Webb and Cox find in favour of pedagogical concepts being interpreted in a subject-specific manner and this leads to a certain categorisation of their findings. They also present transformation as a process linking to the conceptual thinking of the effective teacher, one that at its highest level allows the teacher to make the complex simple, and helps pupils and others to understand something complex by finding new and creative ways to explain it in simple terms. These ideas can be traced to the work of Shulman (1987) and others (HayMcBer, 2000), being developed into a concept of affordances of ICT and the idea of teachers' understanding of these affordances described as pedagogical reasoning (Webb & Cox, 2004). The study recognises earlier research material that had examined pedagogic strategies for using ICT to support subject teaching and teacher's models of how their pupils learn (Ruthven & Hennessy 2002, 33-36). While finding in favour of the idea that using technology can facilitate reorientation of practice and measured development of teacher's pedagogical thinking (Tweddle 1997, Ruthven and Hennesse 2002, Birmingham and Davies 2001) it was asserted that pedagogical

## Transformation and Pedagogy

practices have changed little with the introduction of ICT and as yet few are making use of its affordances.

There has also been some criticism of the types and focus of ICT when taught as a discrete subject in secondary schools, as a narrow subset of earlier ICT applications (Webb and Cox 2004). This line of thought argues that although within the first 1998 version of the National Curriculum, ICT had a distinct focus on programming (systems design, measurement and control systems and machine code), with the spread of computer networks into schools teachers had tended to adopt commercially based sets of applications (e.g. Word, Excel, Access, etc) in the ICT curriculum. An outcome of this can be the avoidance of more advanced theory until pupils reach post-16 education.

More encouraging signs have been found in teachers' perceived confidence levels, (DfES 2001), with 75% reporting they felt confident in using ICT and saying they had received recent training in the use of them, while it may also be shown that the uses of portable computers (laptops) and Interactive Whiteboards are beginning to be established in schools and to be researched. Researchers have tended to focus on certain kinds of impact, such as on student attainment, rather than on pedagogy as such (Boyd 2002 cited by Webb et al. in: Becta 2003, 14), while the possible impact of laptops and more recent mobile technologies on pedagogy may become clearer when studies of their use within changing pedagogical approaches take place (Roschelle 2003, 260-272). Similar findings appear when Interactive Whiteboards are used as mainly presentation devices by the teacher, rather than as a means to enhance interactivity between pupils and between the teacher and class (Becta 2003, 19). Webb and Cox's (2004) categorisation of available research examined a long period where computers had been introduced. It considered a broad context of classroom interaction, and also whether ICT helps to advance pupils' independent learning and decision-making skills. (Becta 2003 15). Their focus on teachers' pedagogy here has begun to explore the likely new roles expected of teachers when less clear narrative structures are involved, such as in use of multi-media learning resources and searching for information and publishing by pupils (Becta 2003, 26, Kozma and Anderson 2002, 389). Pedagogical issues exist for the teacher where the danger of unclear narrative and loosely structured tasks can lead to lack of focus for the pupils,



while it was also shown that teachers need to plan, prepare and manage pupils in different ways to those used previously in non-computer environments. The pedagogical consequence has also been variously described by others, such as in the need for new conversational frameworks or scaffolding (Becta 2003, 27).

While some research has indicated that achievement may be enhanced by collaborative working with computers in school (Clements 2000), others have been less certain (Jarvis et al 1997, Crook 1994, 2003, Siraj-Blatchford 2006, 155) and it is unclear whether such results could be independent of ICT use, since the effectiveness of computer software is likely to be dependent on the pedagogical context within which it is used (Hoyles 2001, 33-39). It has also been suggested that effective student collaboration for learning is not easily achieved (Crook 1998).

The relevance of Crook's ideas (1987, 109-103), to the thinking behind the design of the Eurocollaborator project and case study in this thesis needs mention. Here a psychological issue in computer usage, of how common knowledge gets constructed, would also be relevant to people working in manufacturing industry production with computers. A taxonomy of ways in which computers could enter into joint pupil activity in classrooms was being suggested:

- 1) Interactions at computers: two or more learners gather at a particular place to solve a problem together.
- 2) Interactions around computers: a loosely knit group of people share a number of computers housed in a common space.
- 3) Interactions through computers: possible when the social organisation is asynchronous, e.g. partners separated in time and space but networking creates novel opportunity for users to construct some degree of common knowledge.
- 4) Interaction in relation to some computer application, e.g. common knowledge is resourced by reference to specially made computer applications...such as a hypertext construction of lessons for us as an anchor for collective learning.

Interactions 3) and 4) of Crook's taxonomy, but within a combined industrial and classroom perspective, informed the design of the Eurocollaborator project, where an electronically defined (EPD) aircraft product had to be designed and manufactured

## Transformation and Pedagogy

across school sites in each consortium of schools (rather than the hypertext constructions of lessons in Crook's case). This consideration in the Eurocollaborator project can similarly be described as a series of instructional interactions with the teachers, engineers and pupils in the consortia of schools.

Other implications of collaboration within the Eurocollaborator project and case study, such as those of pedagogical precedence, are examined in more detail in chapters 4 and 5.

Finally, the more recent period between the end of the 20<sup>th</sup> century and the beginning of the 21<sup>st</sup> has been marked by concerns, at least in the USA, that teachers have become largely indifferent to the idea that computers hail pedagogical change (Cuban 2001, 14-16, Oppenheimer 2003, 7). Counter arguments emphasising the computer's ubiquitous value in education (Reynolds et al. 2003, 151-167), perhaps serve to emphasise the complexity of embedding innovation in education (Underwood 2004, Underwood and Dillon 2004).

### **3.3 A REVIEW OF THESE HISTORICAL PERSPECTIVES ON TRANSFORMATION AND PEDAGOGY**

During the early period of introducing computers to schools there was an interest in programming them, which was seen to be a basis for both the new language of the technology and for the learning computers could bring to schooling. Methods of teaching and pedagogy with computers were at that stage unclear, but there was an expectation that they could improve pupils' learning. A development that stands out from this early period was the introduction of new ways to manage programming for school use and to make it a more accessible language to pupils and teachers. While this was initially being addressed through the introduction of new products for learning such as LOGO, there then followed a sustained period of investigation into the potential of programming languages. The perceived worth of these early ideas has evolved throughout two decades or so of computer presence in schools (Hoyles and Sutherland 1989, 208-222, Hoyles et al. 1994, 202-215, Yelland 1994, 33, Clements 2000, 9-47). Papert's (1980) early writings encouraged an approach to working with computer microworlds which has inspired a succession of ideas about ICT and

## Transformation and Pedagogy

learning that could be argued to be no less powerful today, (Twigger et al. 1991, 144-155, Leclet and Wedenfeld 1998, 140-147). From this early work it seems that certain other related ideas about learning using computers emerged, notably those dealing with interactivity made possible for learners (Sutherland et al. 2004, 410). Both of these ideas, programming and interactivity, appear as strikingly new in the literature of that period, from 1980-85, and would have represented new pedagogical precedents.

Literature from the later period examined in this thesis also offers a different kind of emphasis and sets of concerns, including with:

- Central agency guidance/ intervention in the UK (e.g. National Curriculum from 1987 onwards).
- Greater concern with embedding ICT into classroom practice.
- Concern with the nature of learning and access to learning.
- Concern about the quality of adoption of ICT into teaching and learning practices.

The ideas suggest the later period can be characterised by greater emphasis on embedding, which contrasts with the earlier period of computer use in school where computers seemed to be used to pursue more innovative goals, or discovering what computers might bring to learning.

While the early period of introducing computers into schools may have stimulated a questioning of earlier modes of teaching, combined with a willingness to discover how interactivity via the computer could transform learning, this idea broadly meant releasing pupils from older modes of teaching and learning. Transformation of pedagogy with the computer became a consideration in relation to new styles of learning made possible with computers in school, but a lesser one. The computer was harnessed more to delivering than to discovery, while there grew a concern that teachers' pedagogy had barely changed (Cuban 2002) from the beginnings of the earlier period. During this later period there also grew an expectation that

transformation of schooling and learning would result in return for the high financial investment in computers.

### **3.4 WAYS THE RESEARCH QUESTIONS ARE INFORMED BY THE HISTORICAL TREATMENT SO FAR**

This historical treatment has begun to inform my 01 overarching research question, ‘How can ICT facilitate transformation of pedagogy?’ by providing inferences to the related L1, L2 and L3 sub-questions. Because no detailed studies of pedagogical transformation facilitated by ICT have yet been found, or at least where this transformation is explicitly described, the inferences can be said to address the sub-questions only in the following general ways at this stage:

- In providing inferences to the L1 question, ‘How can ICT transform pedagogy?’ evidence across the two historical periods suggested that, while the early period brought experimentation and changes to methods of teaching or encouraged them, these fell short of impacting upon teachers’ underlying modes of teaching. While there was interest in the development of new styles of learning that could arise from using computers, such as in the debate on value of collaborative learning with them (Cummings 1985, 149-159), the actual levels of change in teachers’ methods neither necessarily suggested great pedagogical rethinking nor drew on research evidence about this when it did exist (Sutherland et al. 2004, 413).
- In providing inferences to the L2 question, evidence across the two historical periods suggests that while the early period of introducing computers can be associated to some extent with pedagogical experimentation, a later emphasis on embedding ICT into classroom practice aligned the role of ICT in teaching more with mandating of schooling, at least in the UK, which was not the same as saying that pedagogy was transformed. There was also a feeling that research to that point had been ignored, or not taken account of, the aggregation of research findings into more coherent ideas on pedagogy. It

tended to focus on the functions of ICT and ICT products within subject teaching and what they afforded.

- In providing inferences to the L3 question ‘What is meant by pedagogical transformation?’ I have argued that this involves pedagogical rethinking by teachers in response to new pedagogical precedents. It may therefore be the case that when pedagogy change is an embedding process for its own sake, or where there is a climate of embedding rather than of discovery through teacher action, this is less likely to lead to transformation of pedagogy. It is also possible for a discontinuity to exist between the learning potential of computers and the pedagogy, a phenomenon that has been described by others during the later period (Triggs and John 2004, 426-439).

It has also been unclear, throughout writings examined, that the nature of transformation has been sufficiently defined to provide a meaningful description of it in relation to pedagogy, or to differentiate it from other kinds of pedagogy change. Addressing this shortcoming in my research will be attempted through the development of new constructs concerning precedence in the pedagogical context.

### **3.5 MORE RECENT THINKING ON TRANSFORMATION AND PEDAGOGY AND ITS THEORETICAL UNDERPINNING**

The earlier historical analysis in this chapter suggested two categories of pedagogy-influence, embedding and discovery. It has also been implied that, despite a later embedding period, it has still not been possible to address teachers’ ICT pedagogy needs, while during an earlier discovery period there was less concern for such pedagogies anyway or that it was enough just to introduce computers to the classroom.

My historical categories were not intended to be mutually exclusive; they were to help examine a variety of pedagogy phenomena, which might belong to either or both categories. The issue of what knowledge was being embedded and how the knowledge was discovered is also significant, and this idea will have some relevance during the Eurocollaborator case study, for example where teachers found that they

were inextricably involved in both kinds of thinking or where new kinds of professional knowledge relating to aviation engineering practices were introduced to the design & technology classroom.

The idea of a historical perspective now needs to be developed in the context of theories of learning that have had a prevailing influence during the period, or ways certain ideas can be used to describe and support the idea of transformation in relation to ICT and the introduction of computer into schools.

### **3.5.1 The current discourse on pedagogy and transformation.**

More recent discourse on ICT and pedagogy emphasises the idea that there has been insufficient attention to the impact of ICT on the classroom (McCormick & Scrimshaw 2001, 37-57, Becta 2005, 2, 43, Becta 2006, 51).

This idea can also be traced from earlier studies. For example research into high access to computers on pupils' learning (Gardner et al. 1992), helped to dispel simplistic notions and assumptions linking student attainment in schools and computer usage. When attainment data in this case study was examined on a before and after basis, following broad introduction of desktop and laptop computers to classrooms, the findings did not indicate significant student improvement. Although the research did not set out to examine teachers' pedagogy directly, its researchers did conclude that lack of change to pedagogy might have been a factor in the research findings.

However, this concern with the impact of computers on student attainment may add weight to the idea developed earlier in my historical categories. For example it could be inferred that assumptions were being made by researchers concerning transformations in terms of student attainment scores. These were being anticipated during a period in history when prevailing expectations of teachers were that they would embed an already pedagogically proven ICT, rather than encourage innovative practice or discovery with it.

## Transformation and Pedagogy

The general relationship between ICT pedagogy and theories concerning teachers' pedagogy has already been examined in chapter 2, especially concerning possible challenges to more preceded ideas about what computers and ICT brought to learning, and it remains to describe a possible theoretical underpinning of current ideas about transformation and pedagogy in the context of ICT.

### **3.5.2 Current thinking on ICT and pedagogy.**

Admitting greater complexity to the nature of teachers' pedagogy is perhaps becoming accepted (Calderhead 1987, Mortimore 1999), while ascribing a deeper nature to teachers' apparent indifference to ICT pedagogy has become an issue (McCormick & Scrimshaw 2001, Watkins and Mortimore 1999, Becta 2003, 8, Becta 2005, 43). A difficulty still, despite more than 30 years since the earliest introduction of computers to classrooms, is that insufficient attention is given to the impact of ICT on the classroom (McCormick & Scrimshaw 2001, 37-38), or in supporting the integration of new technologies in school because detailed attention to issues of pedagogy were missing. In the U.S.A. there seems to have been overemphasis on ICT learning as a means of teaching about computers (Cuban 1997), or through focusing overly on knowledge instruction rather than knowledge construction (Sandholtz et al. 1997). This has tended to leave out other important elements, such as the surrounding classroom or school pedagogy, which may also be central to successful learning (Wood 1998, Sandholtz et al. 1997, 12-15, Sandholtz et al. 2002, 4).

Where one particular research emphasis has been on the quality of interactions as children learn with computers (Wegerif & Scrimshaw 1997, Light et al. 1999, 93-107, Littlejohn and Light 1994, McCormick and Scrimshaw 2001, 38), another has been relationships among learners, between learners and teachers and classroom discourse, influenced by social constructivist and situated perspectives (Sutherland 2004). These ideas have allowed more emphasis on the social aspects of learning and offered ways to explore pedagogy with greater sophistication than before, for example taking into account the ways subject and national curricula are being implemented by schools, how teachers themselves think learning takes place or how they may believe their subject knowledge is constructed or should be discoursed in the classroom. The ideas

## Transformation and Pedagogy

here are being presented as different, yet interrelated dimensions of a new and more sophisticated pedagogy model. This is not the same idea as transformation of pedagogy being developed in this thesis though. A strength of socio-cultural approaches is ways they can help define pedagogy change within the cultures that teachers may be said to already work in, for example their subject backgrounds (Triggs and John 2004, 426). However, in this thesis I am raising the questions of whether pedagogy change phenomena are always transformation as such, and whether the idea of transformation is yet sufficiently well-defined to distinguish it from other kinds of (non-transformational) change to pedagogy.

A later idea suggested levels of change in relation to specific uses of ICT, and compared:

- An 'improving of efficiency' level, where ICT was used to provide a more effective means of doing what was already done.
- An 'extending the reach' level, where ICT was used as a major extension to what could be achieved, going beyond the efficiency level.
- A 'transforming' level, which went beyond the level of extending learning.

(McCormick & Scrimshaw 2001, 51-52)

However the transformation level was not qualified beyond being a learning extension. The idea of different levels of impact in a Computer Practice Framework has also been developed by others (Twining 2000 cited by Cox et al 2003, 28), a tactic allowing helpful comparisons to be drawn between transformation and non-transformation, but leaving a difficulty in avoiding oversimplification and determinism. For example might a teacher not change in all three levels at different times, perhaps due to different circumstances, or might it be possible for a teachers' pedagogy to be transformed while operating in an efficiency mode? A more serious difficulty in this work (McCormick & Scrimshaw 2001) is perhaps in the portrayal of the transforming level as more appropriate only to certain subjects such as the arts, or where learning may be defined more or less by the media used. This could imply that new technologies may only bring about transformation in certain subjects, such as with the introduction of electronic painting and drawing technologies to art teaching. Such a position would bring unwarranted complexity to the idea of pedagogy for ICT.



While the idea of levels (ibid, 51-2) helps overcome the difficulty with terminology on transformation and pedagogy, the issues of determinism mentioned may be a danger while it might also be questioned if a transformation would still be possible for a teacher whose subject knowledge appealed to the efficiencies afforded by ICT. In this thesis I argue that pedagogical transformation, as distinct from other kinds of pedagogical change, can be better described in terms of pedagogical precedence. My argument, while recognising that efficiencies may be afforded to particular subject knowledge by particular ICT applications, does not recognise all such affordances as transformational. Nor does it confine transformation to particular efficiencies and subject knowledge.

Although I have argued that affordances are not the same as transformation, and that their consideration bears more directly on my L2 sub-question and therefore can be ignored for the purpose of understanding transformation, Webb and Cox's (2002) report reviewed a large cross-section of research and helped to address a criticism that prior research into ICT pedagogy had not been sufficiently taken into account (Lynch 1999).

The idea that earlier research had been unheeded led to the more recent report to the DfES by members of the Department of Education and Professional Studies at Kings College, London (Webb and Cox 2002). Here the effects of ICT pedagogy on attainment, based on wide review of evidence from published research literature, was examined. The broad conclusions from this report, where ideas on pedagogical reasoning drew on earlier work on teachers' thinking mentioned in chapter 2 (Shulman 1987, Alexander 1992), were also developed along lines of affordances. Here the idea is developed that teachers may use pedagogical reasoning skills to filter and represent knowledge to support learning-affordances for their pupils, while also allowing that ICT may provide very different learning opportunities to before and that teachers may need to develop new pedagogic roles to suit these affordances. The report extends these ideas through introducing writings on more dynamic approaches to knowledge transformation than Shulman (1987) had initially proposed (Hawkrigde 1990, McLoughlin and Oliver 1999, 32-50, Somekh and Davies 1991).

## Transformation and Pedagogy

While Webb and Cox (2004) do use transformation as a general term to describe certain new treatments of ideas as new affordances provided by ICT, they do not further substantiate transformation.

While dealing quite briefly with the idea of a new pedagogy, Becta (2006, 51-54) frequently mention transformation in much of their recent national strategic writing (Becta 2006, 3-86), an approach articulated as moving education from a traditional behaviourist, faculty centred educational model to wards a constructivist, student centred one emphasising self-directedness. This raises once again the issue of ambiguity in the meaning of transformational terminology, although the context of policy and its persuasion may not be dealing with quite the same transformations as in classroom based teaching, learning and pedagogy.

### **3.5.3 Origins of thinking on ICT and pedagogy.**

While ICT transformation has been a rationale articulated in current national priorities, for example to better meet the demands of the contemporary workplace and society (Becta 2006, 3), within published research into ICT and pedagogy it has been suggested that the effectiveness of computer software is likely to be dependent on the pedagogical context within which it is used (Hoyles 2001). This idea has led to attempts at defining more clearly the form ICT pedagogy might take (Underwood 2004, Web & Cox 2004). The disparity between the simplicity of the national priorities and the sophistication of pedagogical contexts suggests there should be renewed urgency in defining more clearly the form an ICT pedagogy might take (Underwood 2004, Web & Cox 2004).

It will be possible to contribute to these ideas by examining the underlying theories that have informed my two historical periods, while informing my research questions into transformation and pedagogy.

### **3.5.4 Challenges to defining an ICT pedagogy.**

An irony is that an increasingly high funding inertia for computers in schools (Sutherland et al. 2004, 413), seems to have grown alongside limited pedagogy

## Transformation and Pedagogy

development or a complacency about the need for one. It has also been argued that not enough rigorous research existed to support the investment and to draw on the research already existing (Lynch 1999 cited by Sutherland et al. 2004, 413).

While in the UK the quality of research available since computers entered schooling in the late 70s and early 80s has been criticised for its lack of rigour and fragmented specialist concerns (Underwood 2004), there have been similar concerns that computers in American schools are underused in learning (Cuban 2001), and of computer work as largely added-on to previous modes of teaching and learning rather than transforming them. Cuban (2002) has also asserted that computer installations can be tainted by economic justification for schooling, by political expedience, as well as having little or no relevance to learning or the real needs of learners, and with teachers having become indifferent recipients of computer hardware and software in their classrooms.

In the U.S.A. there have been misgivings about the idea that computers in schooling really do introduce pedagogical change (Oppenheimer 2003), suggesting that computers have in fact represented a kind of pedagogical misunderstanding or a diversion from the more important teaching of back-to-education basics.

It has been suggested that poor quality of teachers' access to data and information on theories of learning, during in-service and beyond initial training, has been a factor in limited pedagogy development (Bell & Bell 2003). Others suggest that prevailing expectations of teachers may influence pedagogy (Light et al. 1994, 94), for example that theories of learning underpinning many of the approaches to computer use during the last two decades were inappropriate and that drill and practice software used in British first and middle schools from the mid 1980s was unduly influenced by behaviourist/ associationist ideas on ways children learn best. The repeated execution of tasks customised to particular levels of expertise and automated by computer software, had reduced the value of the computer to one providing high-level routine and individualised tuition.

In the UK, attempts have also been made to address the criticism that there was lack of research evidence for the level of investment in computers for schools.

However, in describing the pedagogical findings of research it is useful to examine theoretical underpinnings that seem to have been involved since the earliest point when computers were being introduced into schools.

### **3.5.5 Some theoretical underpinnings of ICT pedagogy.**

#### *Constructivism and ICT pedagogy*

During the early 1980s, when computers were first introduced to schooling, it can be said that Jean Piaget's theories on how children become thinkers were influential. They suggested a staged, somewhat linear approach to cognitive development. Readiness to learn was a major factor. This has been interpreted as teachers needing to wait until learners were ready to progress to new experiences. There is a particular bias in Piagetian theory toward the idea that the use of language is constrained by the stage of intellectual development that a child may be at. Piaget's theory of constructivism therefore presented a staged process, one influencing Papert's (1980) early ideas on how children could construct meaning through computer programming. This construction is the product of a child's readiness to learn, combined with an emphasis on action by the learner. Piaget did not really much consider the role of the teacher in the process. Piaget places an emphasis on discovery learning, for which the presentation of knowledge to children was not really the issue. Instead the child learned through exploration within the learning environment.

While Piaget's theory has been criticised (Donaldson 1978), on the basis that his experiments were flawed, its main constructs seem to have influenced early rationales for the introduction of computers, or helped to justify certain ways pupils might learn from using microcomputers in schools (Papert 1980). These Piagetian constructs may have seemed consistent with the idea that pupils could more readily become formal thinkers, or that in using the new ICT products teachers might be able to tailor instruction more closely to Piaget's ideas of the natural mode of learning.

This early influence of Piaget on pioneers of the school microcomputer should not be underestimated. I have shown it to be present within signal publications on this subject at that time (Papert 1982). This early genesis of thinking on the educational

## Transformation and Pedagogy

role of the microcomputer in schools, has also been described as one influenced by prior pioneering work on Artificial Intelligence at the Massachusetts Institute of Technology in the late 1960s (Boyle 1998, 260-267).

### *Social Constructivism and ICT pedagogy*

Sociocultural, or social constructivist approaches emphasise the interdependence of social and individual approaches in the co-construction of knowledge.

During the last century period of introducing computers into schools there was a resurgence in interest in Vygotskian ideas concerning the co-construction of knowledge, bringing about a shift in the direction of research related to computer-based learning toward fostering social-interactive learning. For example Cummings (1985, 149-159), had shown that the computer can act as a motivator for group work, and helped to explore the idea that co-operative modes of working could lead to both better performance and better learning outcomes.

Research into experimental studies based on collaborative use of computer-based planning (Light et al.1994, 94-106), used four related studies involving different kinds of groups and tasks, and were designed to test certain ideas for collaborative learning:

- Did children working in pairs perform better than children working alone?
- Do any advantages from those working in pairs transfer to a subsequent assessment of performance?
- What sort of psychological processes could be observed or deduced during collaborative learning (as different from children working on their own)?
- What performance and progression through tasks could be measured?
- How could interaction between pupils be described?

There is some continuity with previous ideas of Papert and Minsky and this work. For example, if teachers must learn to exploit techniques, which keep the child as an independent problem solver until they can go no further, then they may be

encountering what Vygotsky referred to as a zone of proximal development at this point (Vygotsky 1986).

It is important to separate Vygotsky and Piaget though. In general terms Piaget paid little attention to social experience and its effect on development. Piaget often treated any notion concerning the causal effects of social factors in development dismissively. His thinking tended toward the idea of adult interventions being at best irrelevant and at worst harmful, a more productive role was sketched for the child's peers, and for symmetrical child-like interactions. According to Piaget, young children, restricted by their egocentricism, were likely to focus on just one aspect of a particular problem and to ignore other aspects of the task which in turn leads to conflict. It was in resolution of these conflicts that Piaget saw the germ of intellectual progress.

In contrast to Piaget, for Vygotsky the social interaction was at the heart of the development process with the child being regarded as an apprentice to culturally elaborated knowledge. Inherent in this is a recognition of the value of asymmetrical relationships and in particular adult-child interactions where the adult scaffolds the child's emerging competencies. It has since been argued that, while Piaget was right to emphasise the importance of child-child interactions, his analysis of the benefits here as purely learning in terms of socio-cognitive conflict are too restrictive (Light et al. 1994). A consequence has been the growth in popularity of Vygotsky's ideas, for example his ideas on scaffolding in terms of framing a mutually supportive co-construction of meaning and knowledge could describe the teacher-pupil interactions in school with certain implications for pedagogy with ICT.

While Piaget and Vygotsky can be said to have many differences, they both share an essentially cognitive orientation and neither has much to say about children's affective experience of learning of the learning situation, or their motivation and self-confidence etc. Vygotsky's particular stance emphasises more the role of learning through instruction, the importance of historical and cultural influences and the idea of social interaction between teacher and more able peer (as cited in John-Steiner and Mahn, 1996). He also introduced particular concepts for describing the Zone of Proximal Development (ZPD), or gap between actual development and higher level,

## Transformation and Pedagogy

which could be achieved with guidance and the idea of egocentric speech and inner speech (Vygotsky 1978).

Vygotsky's ideas on thought and language (1962), have also been developed by Bruner (1996), to explain how teachers' beliefs can be harnessed toward their developing pedagogies when four dominant models of learners' minds were considered:

1. Seeing children as imitative learners: The acquisition of know-how.
2. Seeing children as learning from didactic exposure: The acquisition of propositional knowledge.
3. Seeing children as thinkers: The development of inter-subject interchange.
4. Children as knowledgeable: The management of objective knowledge.

Bruner (1996), describes teachers' personally held theories about how their pupils learn, or explanations which determine action, as folk-pedagogies needing to be taken into account to understand how teachers' beliefs can be harnessed toward a developing pedagogy.

It can be said that Bruner has been mainly influenced by Vygotsky and, to a lesser extent, by Piaget. His central ideas deal with ways language can be said to shape thought and his theory of culture and growth. His three modes of representation; enactive, iconic and symbolic; are testament to these ideas. He deals with Vygotsky's ideas on scaffolding in great depth.

### *Socio-culturalism*

Other recent work on teachers' ICT pedagogy has been important in developing an increased sophistication through socio-cultural theory (Sutherland et al. 2004). Typically teams of teachers and researchers had developed ways of embedding information and communications technology (ICT) into everyday classroom practices

## Transformation and Pedagogy

to enhance learning. The focus has been on teaching and learning across a range of subjects, including English, history, geography, mathematics, modern foreign languages, music and science. The influence of young peoples' out-of-school uses of ICT on school learning was discussed and the idea of creative tensions between idiosyncratic and institutional knowledge creation was described as exacerbated by the use of ICT in the classroom (Sutherland et al. 2004, 413). Similar research has tried to establish processes by which an improved pedagogy for ICT might be developed, for example by directly involving teachers in developing their own improved theoretical understanding of pedagogy (Triggs & John 2004, 426-439). In this research a complex picture of pedagogy was uncovered in relation to teaching and learning, policy and management, subject cultures, professional development and learners' out of school uses of ICT. The subject-situated and mediated aspect of learning adopted led to comparisons of how ICT was embedded between different subjects. To develop this thinking required a mixture of researchers and teachers in mixed subject design teams that focussed on embedding ICT into a small area of the curriculum.

Sutherland's recent research (2004, 414) was situated within a theoretical perspective on teaching and learning that drew mainly from socio-cultural theories (Vygotsky 1978, Wenger 1999, 280, 4-5), taking the socio-cultural concept of 'tools' by which all human interaction is mediated and interpreted. These tools included artefacts (e.g. book, computer), semiotic systems (e.g. language, diagrams), social interaction (e.g. group work) and institutional structures (e.g. national educational policy) and used Wenger's (1999, 55-57) ideas of participation as transformative potential.

For identifying and understanding pedagogy tensions, the project was significant in helping to develop new sophistication, including need for:

- Balancing uses of digital and non-digital tools in teaching and learning.
- Balancing teachers' own philosophical/ subject perspectives to the uses of tools.
- Embedding the uses of new tools alongside existing ones.
- Introducing new models of assessment that reflect new tools and approaches.



## Transformation and Pedagogy

- Accommodation of new approaches that might challenge an existing practice of teaching and threaten a well-established knowledge domain.

### *ICT Pedagogy as affordances*

As already mentioned, this approach relies on attempting to describe the conceptual thinking of the effective teacher (Webb and Cox 2004). This was introducing dialogue about what teachers should do and how they might develop their practices to take full advantage of the affordances of the particular ICT issues in different research findings. These tended to use earlier ideas on the nature of pedagogical reasoning and how knowledge is transformed through teaching (Shulman 1987), the role of ideas, beliefs and values in teachers' practices (Fang 1996), and certain ideas on the role of knowledge of ICT resources that have been articulated in terms of affordances (Gibson 1979, 133-5).

The usefulness of Gibson's (ibid) ideas on affordances in this work has been in helping to suggest ways teachers' prior conceptual schemas might become realigned with potentially new ICT-influenced ones. Such a model of pedagogical reasoning suggests ways that ICT, or new learning environments that should now include the ICT, can be understood or become ecologically balanced within teachers' pedagogy. However, I believe this idea to be predicated on teachers' capacity to re-conceptualise their teaching, or on the idea that re-thinking pedagogical reasoning is itself an ecologically balanced phenomenon akin to this perceived (and hoped for) outcome. A confusion here, between outcome and process, would seem to strengthen the argument that greater clarity on both the nature and conditions of pedagogical transformation is needed.

However, in describing pupils' learning through activities that stem directly from affordances of ICT, it has been possible to build generalisations from varied research in this field and to begin to describe teachers' pedagogical reasoning in relation to ICT.

Pedagogy as affordances has emphasised the importance of:

## Transformation and Pedagogy

- The relationship between different types of ICT use and teachers' beliefs, knowledge and pedagogical practices.
- Integrating ICT with other more traditional teaching methods.
- The impact which ICT has had on specific concept knowledge, on specific skills and processes and how this relates to different pedagogical practices.

It can be said that the idea of affordances has made it easier to identify common sets of issues across the different types of published evidence and to help identify gaps in current knowledge of education and pedagogical practices. Others had developed similar ideas on complexity in pedagogy (Watkins and Mortimore 1999, 8, 3-15), where an increasingly integrated conceptualisation specified relations between its elements: the teacher, the classroom, or other context, content, the view of learning about learning (Watkins and Mortimore 1999, 1-20). These ideas seem to have been developed from Shulman's model of pedagogical reasoning (1987, 1-22, 14.), allowing the whole learning environment, including teacher and pupils, to be considered while deciding what resources and approaches are likely to enable pupils to learn. The value of software and other resources for developing the ideas and skills to be taught so that they can be built into lesson plans could be considered. This emphasises that teachers need to have substantial knowledge of the affordances of the ICT environments they are using. They need to be clear about their knowledge and beliefs about how children learn, through individual exploration, collaboration and/or structured activities, and to teach at appropriate points as pupils progress in their learning.

### **3.6 SUMMARY OF THE RESEARCH QUESTIONS DEALT WITH IN THIS SECTION**

A broad range of materials has been reviewed in this chapter. A focus on pedagogy and transformation has been attempted.

Writings from the earliest period of introducing computers into schools suggest a general belief or early conviction that their use would transform learning and correct common classroom deficiencies (Lawler 1997, 77-78). Transforming teaching,

## Transformation and Pedagogy

because pupils now learned with computers, was a lesser consideration or at least an unclear possibility.

There were certain contrasts found in writings that deal with pedagogy, for example when the earlier and later periods of introducing computers are compared. During the early 1980s there grew an optimism for the improvements microcomputers could bring to learning, or the idea that previous (non-computer) pedagogies did not really work any more in the computerised classroom (Sparkes 1982, 15). However any early optimism that new pedagogy would simply follow the introducing of computers remains unjustified (Cuban 2001, 14-16).

While the literature reviewed in this chapter allowed the research questions to be considered, it has also allowed the writings of others on this subject to be interpreted, and the idea that precedence helps to define transformation in the pedagogical context to be further elaborated. This literature is also suggesting that the value of computers in schools may be a situated one, as well as the idea that pedagogy and pedagogy transformation are too. An argument behind this idea, being developed throughout this thesis, is that situated transformation of pedagogy is a kind of precedence, or can be described in terms of it.

The ways the research questions have supported these ideas can be summarised as follows:

In providing inferences to my L1 research sub-question, 'How can ICT transform pedagogy?' evidence found in literature suggested that early introductions of computers, for example to mathematics teaching, led to an interest in the development of new and more general styles of learning with computers, for example in collaborative learning (Cummings 1985, 149-159). However, difficulty with generalising such approaches to teaching (Brewster 1991, 118-130, Crook 1998, Hoyles 2001), instead suggested a more situated interpretation of their usefulness.

Different interpretations of how ICT can transform learning were shown to be influenced by different theoretical underpinning, for example the socio-cultural theoretical ideas of how communities may create the settings for improved

## Transformation and Pedagogy

professional growth (Sutherland and John 2004). Others have argued for transformation as a process linking more to the conceptual thinking of the effective teacher, such as with the concept of affordances of ICT and the development of pedagogical reasoning from it (Webb and Cox 2004). The work of Shulman (1987), and Gibson (1979), have been used to help introduce more holistic approaches to ICT pedagogy conceptualisation (HayMcbcr 2000), ones which include the teacher, the classroom, or other context, content and the view of learning about learning.

In dealing with my L2 research sub-question, 'How ICT can change pedagogy?', the historical evidence has suggested that, as computers became more widely used in schools there grew a greater interest in teachers' pedagogy (Becta 2003, 29).

However there have been difficulties in deciding how best to support the development of such pedagogies, while perceptions of the complexity and sophistication of teachers' pedagogy have also deepened (Mortimore 1999). Alongside this growth in complexity there is a reaction to shortcomings in simpler more transactional approaches to teachers' professional development (Triggs and John 2004). Some argue that pedagogy has not greatly altered since the early introduction of computers and that few teachers are yet making sufficient use of the affordances provided by ICT applications (Cox and Webb 2004, 260).

Assumptions about the value of computers in learning were questioned as it became obvious that they provided no automatic route to improvement in attainment. The growing interest in socio-cultural theory meant thinking became more recently aligned with the importance of social interaction, the value of adult-child interactions where the adult scaffolds the child's emerging competencies, as well as the idea of mutually supportive co-construction of meaning and knowledge through collaboration. There has been concern that insufficient attention was given to the impact of ICT on the classroom (McCormick & Scrimshaw 2001), due to prevailing traditional approaches which may have largely focussed on interactions at and around a computer.

Others have questioned the value of computers at all, and have described computer-work as largely added-on to previous modes of teaching and learning, or in reality a misunderstanding or simplistic economic justification for schooling rather than for

## Transformation and Pedagogy

transforming student's learning (Cuban 2002, Oppenheimer 2003). The effectiveness of computer software is now increasingly seen as dependent on the pedagogical context within which it is used (Hoyles 2001). These kinds of ideas have led directly to emphasis on defining more clearly the form an ICT pedagogy might take (Underwood 2006, Web & Cox 2006).

The need for embedding ICT in teaching method, as well as the value of directly involving teachers in developing improved theoretical understanding of their pedagogy within research, has been described (John 2004). An increased sophistication in defining teachers' pedagogy here portrays teachers' subject knowledge as an inextricable part of the situated and mediated aspect of their pedagogy. This thinking builds upon previous ideas on how teachers' evolving beliefs can be harnessed toward redefining their pedagogies (Bruner 1996, 152). It also helps in understanding new approaches that might challenge an existing practice of teaching (John 2004). These ideas have been developed during a period where transformation is becoming defined in the pedagogical context, and has become a focus of research and national strategy (Becta 2006, 51).

In providing inferences to my L3 research sub-question 'What is meant by pedagogical transformation?' it has been argued in this thesis that transformation at least implies pedagogical rethinking by teachers and the idea that such thinking can be in relation to precedence, brought about by transformations arising from ICT. Improving the meaning of pedagogical transformation could help development beyond folk-pedagogy (Bruner 1996, 44-65). There were also indications in the historical examination of literature where refinement of ideas was needed, for example to help dispel simplistic notions and assumptions linking student attainment in schools and computer usage (Gardner et al. 1993, Cox et al. 2003, 15, 23, 36).

The theory of learning held may also influence interpretation of what is meant by pedagogy, and aligns with my L3 research sub-question. If teachers have theories about how their pupils learn, however simple or complex, then this can be said to inform their approach to teaching (Bruner 1996, 46), and therefore needs to be taken into account to understand how teachers' beliefs can be harnessed toward a developing pedagogy and becoming effective users of ICT in their teaching.

Examples of writings from socio-cultural perspectives have also been shown to help to define pedagogy within the cultures that teachers may be said to already work, for example their subject backgrounds (Triggs and John 2004), but it has also been argued these may not address the question of whether pedagogy change is always transformation as such, or whether transformation is sufficiently defined to distinguish it from other kinds of change (McCormick & Scrimshaw 2001).

Other theoretical comparisons have been made, for example Papert's Piagetian constructivist framework (Papert 1980), may have appeared too individualistic to provide a basis for understanding collaborative learning (Colbourne and Light 1987, 130). Different theoretical standpoints might therefore provide alternative interpretations of transformation and pedagogy, for example as steps in mental growth based on acquiring new skills (Papert 1980, 1983), compared with social processes being more at the heart of development, and providing the means by which knowledge is culturally elaborated to the child (Vygotsky 1978, Bruner 1996).

The varied perspectives examined in this literature review have been chosen to help introduce diversity of ideas, while contributing depth to the overarching research question: 'How can ICT facilitate the transformation of pedagogy?'

The literature review has also drawn attention to a deepening sophistication and knowledge needing to be taken into account in understanding the nature of teachers' pedagogies and how these develop or change in form.

## **4. THE RESEARCH METHODOLOGY**

### **4.1 THE RESEARCH QUESTIONS IN THE CONTEXT OF THE EUROCOLLABORATOR PROJECT**

It will be helpful at this point to restate the research questions at fig. 1:

**The first, overarching research question:**

**01: How can ICT facilitate transformation of pedagogy?**

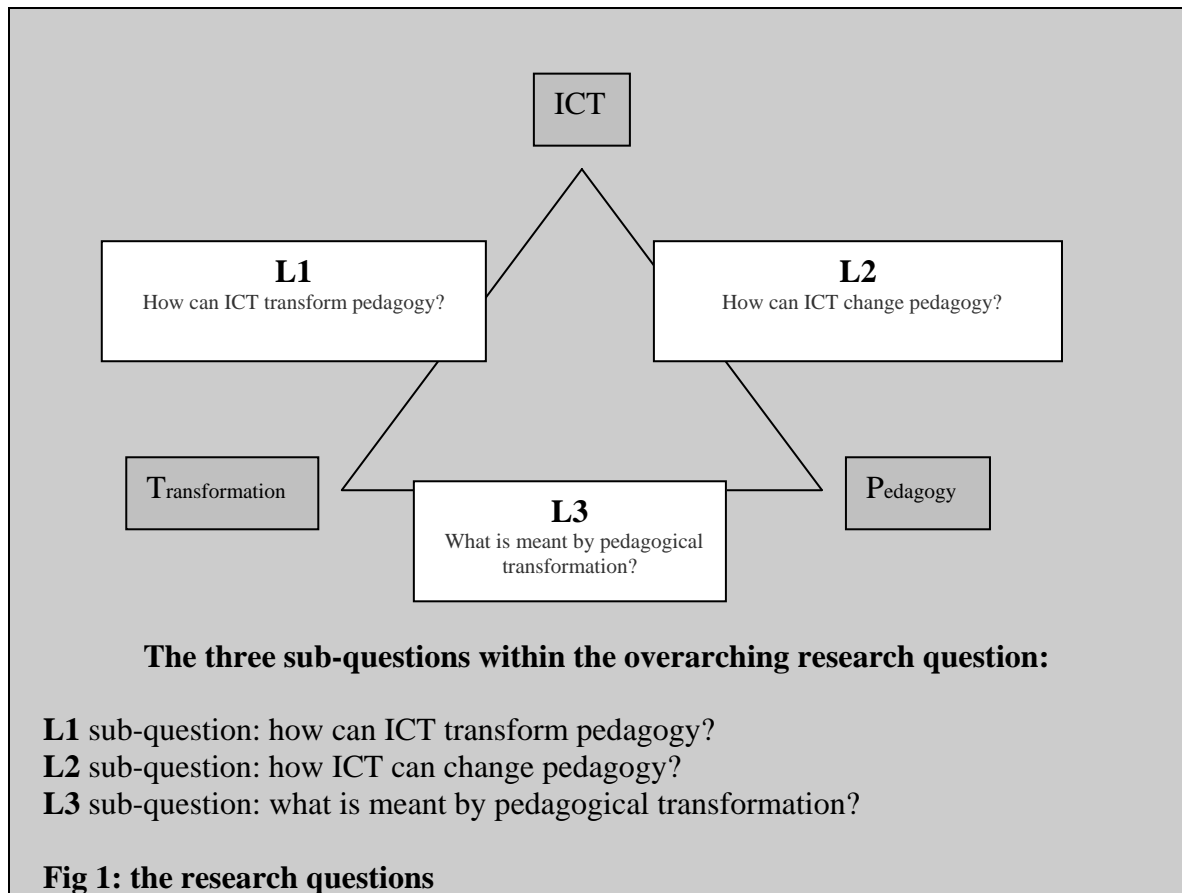

**Fig. 1, source: author**

The methodology for this thesis will be developed through these research questions. They comprise my first 01 overarching research question, ‘How can ICT facilitate the transformation of pedagogy?’, together with my three triangulated sub-questions L1, L2 and L3 (Fig. 1) which are being used to help differentiate between transformational and non-transformational pedagogical change arising from teachers’ uses of ICT. The methodology used in this thesis can also be described at this stage as qualitative case study, drawing in part on some of the traditions associated with Grounded Theory. In this case I was interested in possible ways new forms of pedagogical knowledge could result from using computers and Electronic Product Definition, and was able to observe these situated within design & technology teaching and aerospace industry in the case study.

The research design used a process of analytic induction to develop the idea of transformation, and involved data from the qualitative case study being analysed to help validate the analytical products of the research.

### **4.2 KEY CHARACTERISTICS OF A CASE STUDY**

I examined ways others had used case studies, as all or part of their research designs. For example, case studies have been introduced alongside other field work as overlapping devices, allowing a particular aspect of a topic to be more fully understood or giving more total context to the analysis of data (Okely 1994, 24).

Other researchers have described the purpose of their case studies as allowing comparisons to be drawn against earlier analyses (Mason 1994, 103-4), or in providing vehicles for multiple-site analysis (Burgess et al 1994, 131-4), where certain topics or themes needed greater insights or where greater context was needed for the data than other methods could provide. In each of these cases, case study methods were shown to inform analytical interpretation, which also needed to be worked out and understood and demonstrated important contextual elements needing further investigation. Case study methods can allow researchers to design certain kinds of data collection which can help to highlight particular issues the researcher wishes to follow.

In principle, case study methods are usually motivated by the need to facilitate searches that help identify and map complex interlocking clusters of phenomena, ones which relate to problems that need further understanding. I have not uncovered a strict orthodoxy for conducting and analysing case studies; instead researchers seem to choose one which fits both the investigator and the kind of problem under scrutiny (Turner 1994, 202-8).

Some common characteristics of research design where case studies have been used are:

- The existence of preceding work or thinking, prior to the actual case study, that develops wider frameworks for understanding broad phenomena.



## Transformation and Pedagogy

- The need to move from broad research positions to ones allowing concentration in particular aspects of them.
- The existence of earlier, tentative categorisations that need testing.
- The need to discern more precise happenings, or to show actual responses of people, and to help form certain research conclusions. For example, the need to reveal detail of what actually happens, as different from what is supposed or stated to happen in principle.
- The focus upon situation-specific research phenomena, or clearer identification of behaviours in the case study situation.
- The need to generate data for analytical purposes.
- The need to allow re-interpretation of case study research questions, as well as the focusing of attention on specific materials and the application of research aids.
- The strategy of further narrowing of focus, such as detailed documenting of individual stories.
- The interweaving of relevant background materials and the creation of drafts or descriptions that could support the defining and handling of concepts through creative processes.
- The need to allow comparisons with other related research models.

Theoretical writings on case study method have described the approach in more precise terms. In deciding on a case study approach, notice was taken of Yin (1993) who deals firstly with its scope:

‘A case study is an empirical enquiry that investigates a contemporary phenomenon within its real-life context especially when the boundaries between the phenomenon and the context are not clearly evident.’ (Yin 1993, 12-13).

And secondly with strategies that can be used within the case study enquiry:

‘The case study enquiry copes with the technically distinctive situation in which there will be many more variables of interest than data points, and as one result relies on multiple sources of evidence, with data needing to converge in a triangulating fashion,

and as another result benefit from the prior development of theoretical propositions to guide data collection and analysis.’ (ibid).

The real-life nature of case study enquiry, together with multiplicity of variables of interest, means that data generated is often qualitative in nature. This requires care in the generalising of findings, reliability and validity for conclusions and theory that are built from the analysis of case study data.

### **4.2.1 Generalisability and the case study.**

The generalisability of findings concerns ways their meanings can reasonably be interpreted and developed into useful concepts and theory and the credibility that can be attributed to these concepts and theory beyond the immediate case study situation. The process of data collection, analysis and decisions made by the researcher about what data means in relation to the research questions will condition generalisability in concepts and theory (Mason 1994, 99-102).

### **4.2.2 Validity and the case study.**

Validity can be thought of as the truth condition (Walker 1985, Silverman 2,000). Triangulation is often quoted as the main means to enhance validity and reliability of qualitative research (Bryman 1998, 28-30). Cohen and Manion quote Campbell and Tiske (1994) on triangulation as between methods, involving the use of more than one method in pursuit of a given objective. Another kind of triangulation concerns the verification of statements against data (Strauss and Corbin 1990, 108-109), and the approach to obtaining varied meanings and interpretations of events and interactions so that these can be built into theory, such as the gaining of data on the same event but in different ways.

Where case study methods are being relied upon, validity is determined by strength of claim that is being attributed, or how well or convincing claims can be made from the case study data.

### **4.2.3 Reliability and the case study.**

## Transformation and Pedagogy

Reliability describes the degree of fit between research data and the theoretical basis of the conclusions reached, or 'sense' made of the data (Yin 1993, Walker 1985). A general rule is that high reliability means another researcher could reach similar conclusions from the same data.

Consistency, such as in precision and accuracy in the ways analytic tools are applied, is a component of validity (Cohen et al. 2000), and provides the means whereby replicability over time is achieved.

Strauss and Corbin (1990, 20-30), tackle the problem of reliability through arguing for maintaining a balance between objectivity and sensitivity and the use of techniques to help control the intrusion of bias. They argue for the need to:

1. Think comparatively, comparing incident to incident in the data to help remain grounded, as well as by turning to literature or to experience to find examples of similar phenomena. These can work as instruments to stimulate thinking about the properties and the dimensions of the data (rather than the data itself).
2. Gain multiple viewpoints of an event to determine how the various actors in a situation view it.
3. Gain data on the same event but in different ways, such as through interviews, observations and written reports.
4. Obtain varied meanings and interpretation of events/ interactions so that these can be built into a theory.

Reliability has also been described by Yin (1994, 36), as stability, accuracy and precision of measurement, and by Strauss and Corbin (1998, 73-85), in terms of different categories of questions qualitative researchers need to address.

Developing qualitative research using data from case study approaches also means recognising that there can be varied ways to describe the same event (Janesick 2000, 393), and that a variety of measures may be needed to ensure validity and reliability.

In conclusion, reliance on case study methods involves various strategies to develop analysis and to strengthen claims in achieving analytical roundness and rigour. This includes being clear about what data are telling and what they are not telling, how

well data tell this and how convincing a claim can be made on the basis of the data. This allows the strongest claims possible to be made, without pushing the data too far or making claims that are beyond their capacity (Mason 1994, 99).

### **4.3 THE REASONS WHY THIS RESEARCH IS A CASE STUDY, AND THE SCOPE OF THE CASE STUDY**

My research was dealing with the long-standing problems of teachers' pedagogy in relation to ICT, contextualised within a case study that I claimed to be transformational.

The need for a case study in the design of the research had grown from conceptualisations of transformation and pedagogy I had developed and the review of literature in the areas of teachers' thinking, design & technology subject knowledge cultures and the introduction of computers into schools over the last 30 years or so. This earlier research thinking was part of a continuous, rather than later and segmented stage in my activity, one recommended for qualitative research (Bryman and Burgess 1994, 216-224).

The case study was testing certain ideas on transformation and the relationships between this transformation and pedagogical change. The analytical rigour needed to describe pedagogical transformation and its circumstances lay in the situated design of the case study, the processes of data collection and the ongoing data analysis.

In my data collection I sought key components of pedagogical transformation through the types of question being asked, coupled with the timings of the data collection in relation to progress of industrial transformations taking place within the case study over the two year period of its life. For example this involved data being collected at times that took account of what engineers and teachers were saying about the progress of the case study, designed to give varied ways of describing the same event.

The strength of claims that this data could provide to my research was mainly in terms of ways teachers and their BAE engineer assistants described how computer aided design and manufacture were actually taking place in the case study, rather than any

## Transformation and Pedagogy

official or expected descriptions of computer use. The use of qualitative techniques of data collection and analysis helped me to claim a credible argument about the process of pedagogical change in the face of a transformation in design & technology subject knowledge. I was then able to make general theoretical claims on the basis of having produced a valid account of a process of pedagogical change.

The strength of my claims also involved demonstrating some contours of the process and understanding of relevant situations that seemed to be behind change processes that were being observed. This meant that:

1. In favouring an understanding of what interviewees thought important, it was not always possible to take account of different backgrounds and length of exposure. For example, one of the teachers had been recruited into career teaching as an engineer from BAE SYSTEMS and had an engineering background that allowed him prior insights into electronic product definition and collaborative manufacturing, but the others did not.
2. It was not possible to claim that all people who did not give a particular explanation, for example of how they were using computers and what this brought to teaching, had not actually had the experience. As I was not counting or aggregating though, I did not consider this a major flaw.
3. It was not possible to assume equivalence between all stated experiences.
4. People reported experiences in ways that made sense to them.

These four variables were treated as inevitable consequences of the research design and strategy, of the nature of the phenomena being observed and of the data themselves. As such the products of analysis were treated as guides to understanding, or as indicators of future potential paths of analysis.

Claiming generalisability, validity and reliability in the case study involved asking questions and thinking carefully about what people had said. Generalisability of the case study involved considering replication, and my approach here included:

- Early exploratory study, helping me to make some boundaries and including timings within the case study, people and peoples' personal meanings.

## Transformation and Pedagogy

- Developing my theory through selecting from my case study data, considering similarities and differences, looking for hierarchical constructs, reducing data and devising crude theoretical models.
- Testing my theory, to see if it could be generalised and be meaningful to others.

Validity in the research design and in the case study encouraged triangulation through gaining data on the same events from two main groups of people, teachers and engineers. Additionally, pupils were interviewed and all of the interview data from the three groups was stored in a single NVivo project for analysis. The study was developed with consideration for the need for construct validity, internal validity, external validity and reliability through taking care to select appropriate instruments for the concepts being studied, and achieved through the use of multiple sources of evidence (Yin 1993). A fundamental for internal validity, where certain conditions are said to lead to other conditions, dealt with the relationship between precedents in the case study and the phenomenon of new pedagogical practices, theories, and beliefs that appeared to be associated with them. Internal validity was demonstrated in the possible relationships between certain phenomena and changes to pedagogy arising from the case study, for example through developing increased understanding of ways precedence seemed to influence teachers' thinking. External validity dealt with generalisability of the findings and was situated within secondary design & technology teaching, but with a proviso that broader external validity might be developed from this work.

Reliability; or the stability, accuracy and precision of measurement (Yin 1994, 36); in this case was influenced by both the design of questions and the conduct of the interviews for the three groups of people in the case study. Every effort was made to ensure that the questions were well designed, including the testing of them in the trial interviews at a school in Lancashire.

In response to the ideas of Strauss and Corbin (1998), certain guiding questions were used during the case study interviews and were allowed to change over the duration of the project, beginning in more open form and becoming more specific and refined as the research moved along.

A variety of other measures were considered to ensure validity and reliability, including the ideas of Janesick (2000, 393), who has advised that while there is no one way of describing an event it is possible to strengthen research through:

- A clear statement of the intended processes and outcome, described in a model that traces the causal flows and is explicitly clear about the conditions within which the program operates.
- The development of clear units of analysis.
- The application of well defined and tested field procedures for data collection, including sets of questions for teachers, pupils and engineers involved in the case study which were pre-trialed and evaluated.
- The creation of a case study database archive, in the form of NUD.IST NVivo software, allowing an explicit presentation of key evidence from which to draw conclusions (available from the author). Later in this section I will explain more fully how this was developed.

### **4.3.1 Scope and limitations of the research.**

The scope of the case study has been developed in relation to the 01 overarching research question and the three triangulated research sub-questions. This allowed me to discriminate in favour of situations where ICT seemed to have brought about new kinds of pedagogical precedent in the case study, or was un-preceded, and where it had not. It was these phenomena of pedagogical precedence that were considered as within the scope, ones associated with my L1 research sub-question. On the other hand, where ICT seemed to have possibly changed pedagogy as in my L2 sub-question, but not necessarily transformed it, these phenomena were considered to be outside the scope of the case study.

A methodological limitation of my research could have been my reliance on interviews for providing data on pedagogical transformation. In response to this idea, Yin's (1994) ideas on the strengths and weaknesses of interviews were considered. On the one hand, interviews can provide the following strengths:

## Transformation and Pedagogy

- Can be targeted, e.g. tend to focus directly on the case study topic.
- Can be insightful, e.g. can provide perceived causal inferences.

On the other hand, interviews can introduce the following weaknesses:

- Can be biased due to poorly constructed questions.
- Can lead to response bias.
- Can result in inaccuracies due to poor recall.
- Can fall into the trap of reflexivity, e.g. interviews giving what interviewer wants to hear.

In consideration of Yin's advice, sample data were collected during trial interviews and evaluated with particular care and attention to the following:

1. That questions needed to focus directly enough upon the case study topic.
2. That questions were sufficiently insightful.
3. Accepting the idea that there was room for improvement in the construction of questions, to help avoid bias.
4. The idea that the questions, or questioning, can lead to a response bias.
5. The need to consider and beware of possible weaknesses, such as reflexivity or the interviewee giving what interviewer wants to hear.

In consideration of Stake's (1995) advice when only selective use is made of case study issues, I took care to ensure that the perceptions of individuals in the case study were balanced with understanding of group perspectives and other influences. This involved protocols being developed using sets of questions that were designed to provide the necessary triangulation on sets of common issues for different groups interviewed, and the careful preparation of the related yet different, sets of questions. The questions also had to be open to exposing some of the nature of transformations, as actually experienced by those involved, and to allow pedagogical issues to be exposed from different interviewees perspectives.



#### **4.4 GROUNDED THEORY AND THE RESEARCH METHODOLOGY**

The analysis of the data has resulted in some interesting categories of transformation and pedagogy being developed. These ideas were influenced by Grounded Theory and while interpretation of their generalisability will remain a challenge due to the nature of qualitative methodology (Manion 1994), there appeared strong grounds that could be developed for accepting that pedagogy may be significantly influenced by precedence, and that this may influence development of new pedagogical practices, theories, and beliefs.

Grounded Theory has become widely cited as a prominent framework for the analysis of qualitative data and frequently referred to during reports on research (Bryman and Burgess 1994, 217-224). This has been influenced by the desirability of making theory that is grounded in data.

The qualitative nature of data drawn from my case study was initially voluminous, unstructured and relatively unwieldy in its nature. I had been conscious from an early stage that qualitative research emphasizes that analysis be a continuous and interwoven aspect of the research process. The relevance of Grounded Theory approaches involved maintaining the association between my qualitative data and their original context. Bryman and Burgess (1994, 219), describe this challenge as avoiding 'loss from the moorings' in the family groups to which interviewees' replies pertain.

A process of coding served to organise transcripts and other data collected and my development of initial concepts, in order to develop some building blocks of theory. The conceptual categories to be subsequently developed were grounded in both theoretical perspectives that had been applied to the research design and in the data that had been collected from the case study. Bryman & Burgess state (1994, 220), that there is an issue with central research ideas emerging near the end of fieldwork, rather than the beginning. In my case I found it necessary to develop significant conceptualisation in advance of the fieldwork, which was subsequently shaped in the light of what the case study data seemed to be saying.

## Transformation and Pedagogy

I had originally wanted to contribute to new theory on teachers' pedagogy in relation to ICT, and addressed this goal in my research by developing some new concepts which I perceived as possible building blocks of this theory. Although my new concepts began as little more than extensions of codes, I felt that these would later be developed into more abstract conceptualisations. This approach was an iterative interplay between my data and my analysis, one that is a tradition of Grounded Theory. The desirability of making theory from data was informing my methods of analysis; for example in terms of coding, the development of different kinds of codes, as well as approaches to concept creation; using NUDIST as a tool to aid my thinking. While I was aware of the risk that computer programs can condition the analysis that is undertaken, Grounded Theory seemed also to have influenced the development of this type of software and I chose to use it to allow me to more readily discern certain themes that could emerge as core elements in my research.

The ways in which I subsequently used NUDIST software as a tool to aid my research are elaborated further at the end of this chapter. Traditions developed from Grounded Theory approaches were therefore being used to aid the analysis of transformations, and possible signs of pedagogical changes within my case study. I used ideas drawn from traditions of Grounded Theory to suggest a causal flow (fig. 4) after the ideas of Yin (1993). This method of illustration did not imply that the process of transformation was sequential, however. Rather, it was intended here as a loose framework within which transformation phenomena that developed from the case study could be more easily identified and examined as the research thinking progressed.

During the thesis this illustration (see overleaf) was revisited and refined into successive iterations as a strategy for representing the data on transformation and pedagogy and as a device to explain ways meanings from the analysis of the data evolved. The designs for these successive iterations were informed by my 01 overarching research question, the L1-L3 research sub-questions, and the pre-conceptualisations on transformation and pedagogy that I had developed earlier. The ideas developing from these sources turned out to be complex ones, needing to be addressed from multiple standpoints and multiple perceptions of those interviewed in the case study. Using approaches derived from traditions of grounded to address this

## Transformation and Pedagogy

complexity allowed more generalisable theory to be developed than other approaches, such as via representative samples, would have done (Yin 1993, Black 1999).

Fig. 5: framework for analysing transformation, first iteration.

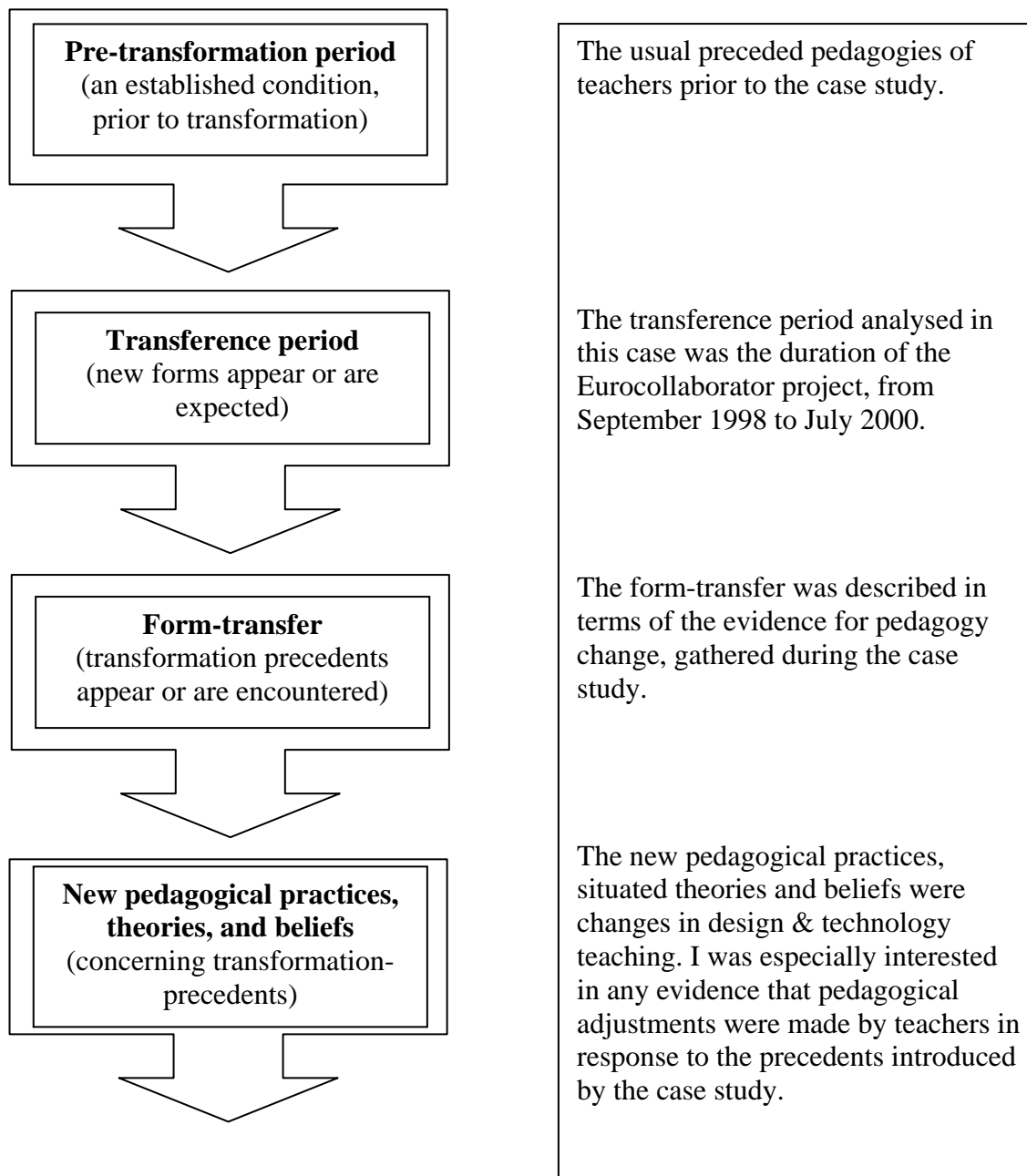

Fig. 5, source: author

The influence of Grounded Theory on this approach was in terms of its perceived suitability for dealing with the issue of teachers' thinking and beliefs, and ways the data collected during the case study could add meaning to this.

## **4.5 THE DATA COLLECTION IN RELATION TO THE RESEARCH METHODOLOGY**

The process of data collection is described under five headings: Who? What? Why? When? How? While these questions will overlap in terms of this research, it will be useful at this stage to consider them under separate headings.

### **4.5.1 Who collected data, and about whom was data collected?**

I collected the data, gathering most of it from informal meetings and taped interviews with teachers, engineers and pupils in participating schools that I visited. Interviews with teachers and pupils were always held at their schools and generally took place during lesson times when I could visit. The project had been designed to include regular project-support visits from a BAE link-engineer, who was an aerospace employee assigned to a school or group of schools for the two-year duration of the project, and I would usually be able to gather data when I accompanied different engineers into different schools during the two year life span of the case study.

Teachers, pupils and engineers were interviewed during the case study to find out what they had to say about what they were doing. The mapping and timings of these interviews is explained at fig. 6 in later in this chapter. Initially, 49 schools expressed interest in participating in the project and attended a BAE SYSTEMS conference to discuss the two-year proposals (Appendix 9). The majority of these schools contributed to the project, being kept up to date via progress letters from BAE SYSTEMS (Appendix 2), but for the analysis of data I drew especially on interviews that had taken place in seven secondary schools and four UK regions, Lancashire, Yorkshire, Buckinghamshire and Wiltshire. These schools were involved in developing and building three of the six planes that were being constructed by teams of teachers and their pupils during the case study.

There was a two-way relationship between the design of the case study and the data collection, one that also took account of the two-year life span of the case study. Sampling was conducted in an ongoing way over the two years, although more interviewing was conducted in the second year to allow for pedagogical challenges

## Transformation and Pedagogy

presented by the project to become manifest. This was in contrast to other kinds of sampling that could have been chosen, such as statistical ones, which I felt might have reduced pedagogical transformation to more representative sampling of the population involved in teaching design & technology where computers had been introduced.

The design of questions asked of individuals within these three groups had taken account of the research questions. For example, engineers were asked questions which dealt with their perceptions of the work they were doing in the project, how they saw their ability to influence the work of pupils and teachers, their own beliefs in the learning process, any changes to working practices as well as their views on the role of ICT. Pupils on the other hand were asked questions on how they saw their working practices in Eurocollaborator as new or different, what they perceived as their learning, what they were learning different and what they thought of the role of ICT.

To ensure that questions were matched to criteria for analysis, three sets of questions were developed and trialled at a BAE Network school in Lancashire on Tuesday 5<sup>th</sup> October 1999, including with a teacher, a pupil and an engineer working on the project. This early sample of data was examined carefully to allow strengths and weakness in the design of questions to be considered (Yin 1994).

I decided against the idea of attempting to analyse student data in direct pedagogical terms, or in the same ways that I was analysing data derived from interviews with teachers and engineers who were teaching the pupils. This decision related to my judgement that there needed to be a separation of my ideas in relation to teaching and to learning, for example that learners might not always learn as teachers expected or assumed. This allowed the learning of pupils, as actually described by them in relation to what they were doing in the case study, to be considered separately yet related to any transformations taking place. This strategy also allowed me to establish distance between the analysis of pedagogy and the positive framing of the interview questions, for example pupils might not agree that the project was an improvement in their learning or in any significant ways different to how they were usually taught. Further analysis of this data in relation to teachers' pedagogy is possible should this be decided necessary. This is explained in more detail, with examples from this pupil data, from node 27 of the pupils' data, at the end of this thesis (Appendix12), the

whole NVivo project itself being available from the author.

### **4.5.2 Why were these data collected?**

The data I collected included:

1. Interview (taped interview data were collected at points during the case study life-span between 1998 and 2000).
2. Observation of practice, including discussions and at meetings (minutes, videotapes, hard copy of e-mails).
3. Observation of the design & technology products being developed (drawings, computer models, mock-ups and final pieces of the consortia Eurocollaborator aircraft).

The research questions focussed on a need to gather data on pedagogy-phenomena from teachers, or on what teachers said about teaching and learning during the project. This would allow development of pedagogy concepts to be grounded in the data, inferring from words being used mainly by teachers, and through exploration of patterns.

Reasons for interviewing pupils and engineers, as well as teachers, had grown out of my literature review, where I realised a deepening sophistication was developing to more properly understand the complexity of teachers' pedagogy. This literature review continued long after the case study and my thinking here was further helped by others working in this field (Mortimore 1999).

At the time of the case study, I felt that the engineers would contribute to the development of new pedagogies and would assist teachers in dealing with the unprecedented aspects of the project as they worked together on the plane building. Although engineers were not acting in the same capacity as teachers, I noticed during my visits that they would typically join in class lessons, adding important perspective to these. On some occasions engineers would lead a lesson or activity, just as a teacher might teach the class, or assist when teachers wanted extra help. Engineers in this case study were not therefore acting in the general, perhaps more typical capacity of outside visitors who just gave talks to the class about their work. Instead their

## Transformation and Pedagogy

involvement with pupils and teachers was highly focussed on the demands of the two-year collaborative plane-building project that the project represented. This involved helping to bring radically new conceptualisations of manufacturing to pupils, including plane assembly, time-lines and milestone stages that had to be reached within each consortium of schools. This also implied that the engineers were managed and co-ordinated, a process that was accomplished centrally from BAE SYSTEM's education department at Warton Aerodrome in Lancashire where I was also based.

From an early stage, I noticed that the case study was revealing two particular pedagogical contexts that seemed un-preceded. Firstly there became a difficulty for teachers in interpreting Electronic Product Definition within the more usually preceded design & technology approaches in lessons, and secondly I noticed a need to develop suitable pedagogical representations of the new knowledge of plane manufacturing required, allowing it to be accommodated and understood by pupils. Help was more easily provided centrally with the latter by developing a variety of published guides and software tools, which were distributed to the teams by BAE SYSTEMS (Appendix 1). However, while this problem was relatively easily overcome (and could have been provided in the absence of such a large scale project and case study) this was less true of the issues surrounding the introduction of Electronic Product Definition to design & technology subject knowledge, a situation which needs some further explanation at this point.

While the latter situation (of manufacturing representations for the parts of planes) might have been expected, the former (of manufacturing product definition for multiple team assembly) was found more difficult, being concerned with the more complex idea of avoiding ambiguity in shared manufacture. If individual or school teams altered their share of the plane, this would introduce errors at the plane assembly stage, an issue that Electronic Product Definition had been developed specifically to eliminate in large scale collaborative manufacture. This 'Integrity of Design Intent and Single Focus' (Broughton et al 1990), was how EPD avoided recreating or re-originating data at different stages, particularly at handover points between functions during industrial manufacturing. This meant relying solely on a single digital product model, one where parts and assembly were not allowed to be redefined by individual designing and making activity in the schools. This was quite



different to the usually preceded ways pupils and teachers worked, and therefore required new teaching. While the problems of ambiguity were overcome from the practical point of view, for example by the appointment of project co-ordination engineers for each project plane (named engineers who became responsible for communicating project procedures and priorities to the schools), I was especially interested in data that reflected this difficulty because it seemed directly concerned with my need to more fully understand the nature of pedagogical change in relation to transformation, and seemed to bear upon the research questions.

### **4.5.3 When was the data collected?**

The period of time when most of the data were collected was between July 1998 and July 2000. The precise dates and times when data were collected are documented in the NUDIST NVivo project, alongside each transcript. The dates of key interviews are illustrated at Fig. 6 overleaf, with names of interviewees anonymized in accord with the ethical requirements of research:

**Fig. 6: Record of interview data collected during the case study**

Site	Location	Date	T	E	P	Plane
Our Lady and St John's School	Blackburn, Lancashire	05/10/99	✓	✓	✓	C3
Hessle High School	Hull	22/11/99	✓	✓	✓	C1
Hodgson High School	Poulton le Fylde, Lancashire	24/11/99	✓	✓	✓	C2
Lancaster Girls Grammar School	Lancaster, Lancashire	24/11/99	✓		✓	C4
Bishop Rawstorne School	Croston, Preston, Lancashire	23/3/00	✓	✓	✓	C4
All Hallows High School	Penworthan, Preston, Lancashire	5/4/00	✓	✓	✓	C3
Priory High School	Penworthan, Preston, Lancashire	5/4/00	✓	✓	✓	C3
Royal Grammar School	High Wycombe, Bucks	16/5/00	✓		✓	C5
Tomlinscote School	Frimley, Surrey	17/5/00	✓	✓	✓	C5
Aylesbury Grammar	Aylesbury, Bucks	16/5/00	✓	✓	✓	C5
Weald School	Billingshurst, West Sussex	17/5/00	✓		✓	C5
George Ward School	Melksham, Wiltshire	25/9/00		✓	✓	C5
BAE SYSTEMS	Warton, Lancashire	05/10/99		✓		C2-5
BAE SYSTEMS	Samlesbury, Lancashire	23/03/00		✓		C2-5
AIRBUS EADS	Filton, Bristol	07/06/00		✓		C6
MOD ABBEYWOOD	Filton, Bristol	11/08/00		✓		C5

**Notes:**

- o These dates refer only to appointments where I was allowed to interview people who were involved in the case study.
- o Many other visits, providing non-interviews data or other information, also took place but are not included in this record.
- o All of these interviews were taped, and all recordings were transcribed by me into Rich Text Format and entered into NVivo
- o The numbers of people interviewed varied from 1-3 of each type (teachers, engineers and pupils) on each visit.







**Word Count in NVivo:**

Teachers: 13,228  
 Engineers: 12,068  
 Pupils: 17,123

**Total words in project:**

**42,419**

**Fig. 6, source: author**

KEY TO PLANES	
<b>C1</b>	
<b>C2</b>	
<b>C3</b>	
<b>C4</b>	
<b>C5</b>	
<b>C6</b>	

#### **4.5.4 How were the data collected?**

Throughout my two-year 0.4 secondment to BAE it became customary for me to accompany link-engineers on their visits to the schools, organised on a rota basis during my weekly two-day stays in Lancashire. This allowed me to collect interview data from individuals at the schools visited while the case study was in progress. While teachers and pupils were always interviewed in their schools and in school time, I was also able to interview engineers at other times, such as at the BAE Warton Aerodrome education department offices or from their factory located places of work.

My questions were designed to allow interviewees to describe transformation and pedagogy during the case study, in the context of project. I was especially interested in mention of problems or issues where they might be describing the character of the transformation as it began to bear upon their prior practices. A particular issue was the different kinds of working practices required of them, and whether any changed forms of teaching and learning seemed to be involved. Data concerning these possible changes were analysed and further described through refinements to illustration 2, referred to earlier in this chapter.

Three sets of questions were designed to correspond with the single set of generic themes, which were as follows:

1. How is it interviewees are working?
2. Can interviewees show examples of the ways they are working?
3. Do interviewees think these ways of working are making them learn better or differently?
4. If so, can they explain how this is so?
5. Can interviewees show any examples, which show that something is better or different?

It is necessary to mention at this point that I did not expect the interviews of pupils to work in the same ways as for the teachers and engineers. This was because the thesis is really about teachers and their sense of pedagogical transformation. In fact the pupil data did help to inform the case study, but detailed discussion of this will be a focus

## Transformation and Pedagogy

for follow up work.

These questions had been developed from five, research focusing, themes which were associated with my research questions:

### *Theme 1, the aircraft industry.*

This concerned the ways the project was designed to allow insights into aerospace manufacturing approaches, as well as to give the pupils and teachers first-hand experience of using them.

### *Theme 2, Using computers.*

This concerned the ways the case study was able to examine situated the uses of computers in design & technology during the project, as well as in manufacturing approaches, such as the exchanging of detail of progress and issues surrounding product integrity between interviewees from different teams working from the same Electronic plane Product Definition.

### *Theme 3, working with people, e.g. pupils or teachers in other schools.*

This concerned the nature of partnerships that were forged as a consequence of the case study. For example, to work successfully, the schools in each consortium needed to develop a relationship that had not existed previously, such as interdependence and a capacity to work efficiently together.

### *Theme 4, Computer Aided Design.*

This concerned ways the case study could examine the effects of introducing new kinds of design & technology processing, such as shape and form manipulation, complex technical detailing and the exchange of files using Computer Aided Design software between different people working on different but adjoining components. The project was also provided with industry-standard software and training to the schools, allowing schools to work within a common manufacturing assembly.

*Theme 5, different ways of working learned during the project.*

This concerned ways the project allowed the schools to experience new ways of working which were introduced to represent current industrial practice, allowing people to reflect and to compare these with previous modes of practice.

**4.5.5 Criteria developed for reviewing the interview questions.**

In designing the interview questions, the guidance on the strengths and weaknesses of interviews already mentioned was borne in mind (Yin 1994). The sample data collected using the trial questions were evaluated in terms of how well questions seemed focus upon the case study topic, their insightfulness, the avoidance of bias in questions or questioning, as well as for evidence of reflexivity.

The problem of poor recall was overcome by taping the interviews. Taping was subject to interviewee agreement. The questions were also discussed with the BAE SYSTEMS project manager (Appendix 7). This approach ensured that the same information was obtained from each person, with the interviewer able to explore pre-determined areas (Verma & Mallick 1999).

Some schools adopted a co-ordinating role in each consortium and were perhaps more active than other schools in the development of the final plane model. This extended into the behaviour of the pupil teams who would initiate communications with other pupils in the other consortium schools (Appendix 10). In some cases this leadership role seemed to be related to a school having been provided with equipment by BAE SYSTEMS on the understanding that this would be shared with the other schools. In other cases there was a particularly strong interest in the work of the project, due to a local reason, for example geographical proximity to a BAE SYSTEMS factory or the interest of the teacher who was leading the pupil team. The existence of these lead schools influenced ways data were collected, for example by helping to identify times when interviewees would be available or providing information on stages of the case study of particular interest or possible relevance to the research questions.

#### **4.6 ETHICAL CONSIDERATIONS**

The need to observe ethical issues (Stake 1994, 244), was acknowledged.

Concerning the interviewing of participants, a transcript of the tape was to be made and a copy sent to each interviewee allowing responses to be amended/ commented upon. It was explained that the taped data would be confidential and the interviewer explained its purpose before the interview began, for example to ensure that inaccuracies were avoided.

Attention was also to be given to help counter any possible prejudices and/or biases of the researcher (Stake 1994), that might influence the collection and interpretation of data. For example, the need to take care with gender issues and to ensure that the views of females and males were equally considered.

The headteachers of all schools participating in the project had already agreed to the case study and to the visits of the researcher for interviews following consultations with them during 1997-8, initiated by BAE SYSTEMS at schools-liaison conferences in Lancashire. The day-to-day contacts with school were organised via the BAE SYSTEMS link engineers who established direct communication, such as by telephone or email, with the teacher leading the project. Sustaining continuity of experiences for persons involved in the case study, over the two years of its life, was achieved with remarkably few changes needed in the schools and BAE SYSTEMS. This was achieved in various ways, for example by enlisting pupils who had just begun work on two year schemes of work or by creating groups that would be active outside the formal curriculum working in 'twilight' mode. A senior BAE SYSTEMS engineer was contracted to work for the two-year period to co-ordinate all engineers and school-based teams, requiring release time from his department at Warton Aerodrome.

The data collection processes involved interviews with teachers, pupils and engineers and therefore ethical issues needed to be considered to avoid any harm being caused. Other factors, such as trust and confidentiality, had to be considered as well (Creswell 1998, 132-133).

## Transformation and Pedagogy

Protocols were developed for entering schools involved in the case study and for setting up and conducting the interviews. These were agreed in outline with the headteachers of schools during the BAE SYSTEMS schools conferences, where the project and background research were placed on formal agendas for discussion. In the early part of 1998 and 1999, headteacher conferences were held in Warton and in Blackpool where the initial project ideas were included for discussion. Later conferences, during the running of the case study, were assisted by videoconference, the Warton BAE SYSTEMS site providing the hub for a multi-point videoconference involving representatives from each of the different regions participating. Teachers from neighbouring schools travelled to agreed locations for these conferences, which typically would last up to 2 hours. The cost of the conferencing was borne by BAE SYSTEMS. It was at these conferences that more detailed protocols for visiting and interviewing were discussed and agreed with senior staff from the schools.

It was normal for the teacher in each centre to help identify pupils who would be willing to be interviewed. The interviews were held in seclusion, usually in a room or office near to the Eurocollaborator classroom, and only the interviewer and interviewee were present during the interview. The interviewer would mention the rationale behind the research on the project, with a view to gaining trust (Lincoln and Guba 1985, 290), and ask for interviewee consent for the interview being taped. A copy of the transcribed taped interview would be sent to the interviewee in case any changes were needed.

While this advice has been useful in building research that has been ethical in its design, more recently the British Educational Research Association (2004) has updated its own guidance for educational research, which I have also considered carefully. The association was formulating its guidelines by the time of my case study, while the principle of adopting them was agreed for the first time at its Annual General Meeting in August 1992.

My approach to using the BERA guidelines, and to fully recognise the kinds of academic tensions that a multi-disciplinary community generates when dealing with complex research issues in education contexts, was to discuss carefully the processes of conducting my research with research staff at University of Bath, and then the

sponsor (BAE SYSTEMS) to ensure agreement on approaches that would be justifiable and sound.

From an early stage, prior to my research, I had already been addressing pedagogical issues of truth and reality as a practitioner and author of school texts while seconded to the Royal College of Art Schools Technology Project, and by the time of the research had been accredited by the then DfES as an Advanced Skills Teacher. I furthered my understanding of the concepts of research data, reliability, validity and subjectivity learned during doctoral study at University of Bath where my research became registered, a process that allowed me to undertake critical analysis of certain basic tenets in my chosen research area and to enhance its intellectual capital through the creative tensions it produced.

Because, as researcher, I was also a participant in the research it is necessary to mention some specific ways the research was consistent with BERA principles and guidelines. These concerned the ethical principles and conduct of the research, how it respected the persons involved, together with the knowledge, democratic values, quality of educational research and academic freedom that building the research and its findings required.

The following is a summary of specific issues concerning the conduct of my research that were addressed using the most recent BERA guidelines (2004) under its three main headings. Specific points from within the BERA guidance document, which I have identified using the same numerical codes as is found in this guidance (the numbers I use in brackets), help to illustrate particular ways they applied to my research:

1. Responsibilities to participants in the research.
2. Responsibilities to sponsors of research.
3. Responsibilities to the community of educational researchers.

### 1. Ways in which responsibilities to participants were recognised.



## Transformation and Pedagogy

These included how participants understood and agreed to their participation without any duress, prior to the research getting underway. This involved gaining the understanding of participants in the research (11), for example their understanding of why participation was needed and how the research would be developed and reported. The possible teacher participants were introduced to the research ideas at their attendance at a whole-day pre-project meeting with BAE SYSTEMS and myself in September 2008 and they had contributed ideas to focusing themes, ones which later helped form questions and the analysis of the research. The sponsors invested considerable time during this early period discussing possible case study designs with senior staff at the schools who wanted to be involved. The chosen design was eventually named 'Eurocollaborator', a name that headteachers chose during a three-day residential meeting in Lancashire early in 2007. During this meeting, which dealt with a wide range of issues concerning ways the company worked with the schools, the manner of reporting the research findings through an academic research degree program was also agreed. I subsequently reported on my progress with the research to the headteachers at regular intervals during the period I was seconded by BAE SYSTEMS in Lancashire.

While BERA regulations concerning issues of deception, right to withdraw and vulnerability (12-18) were being observed within a school-managed teaching and learning environment, and subject to normal school protocols, I did recognise the bureaucratic burden of the research on people (19) and minimized its impact on the pupils and teachers by visiting them during normal class time and as a participant in their lessons. Throughout this process, privacy (23) was accorded by confidential treatment of participants' data and recognised through its anonymous treatment in the thesis.

The debriefing of all participants at the conclusion of the case study (29) was achieved through allowing teachers to comment formally on the usefulness of the project to them personally, communicated in writing to BAE SYSTEMS, while all participants were invited to openly discuss and contribute to the findings at an exhibition and celebration of the case study, held in school time at RAF Cottismore in July 2002. This was attended voluntarily by most of the pupils who had been involved nationally in the case study, accompanied by many of the teaching and senior staff

## Transformation and Pedagogy

from the schools involved, and allowed all pupil teams to view and talk about all six planes that had been collaboratively constructed as well as their experiences over the two-year period.

### 2. Ways in which responsibilities to sponsors of research were recognised from the earliest stages of my involvement.

While the my research had been supported by a 0.4 secondment to BAE SYSTEMS, the agreements for commissioning it (32) were also influenced by my terms of employment as a seconded Advanced Skills Teacher (A.S.T.). I was working to nationally formulated expectations of the Advanced Skills Teacher Scheme, being seconded from my position in a Wiltshire secondary school to support best practice in BAE SYSTEMS' national network of schools. The idea of carrying out research into teachers' pedagogy had been influenced by my earlier involvement in the national A.S.T. scheme rather than the sponsor, and no set deadlines were imposed for the completion of this research. BAESYSTEMS sponsored my secondment for three years as an AST, while also collaborating in this with the Specialist School Trust.

One of the terms of my secondment was that BAE SYSTEMS would facilitate the registration of my research at Bath University, to ensure academic rigour, which they undertook between 1998 and 2002. While this did cover the first three years of research period, the subsequent six years to the present time have been entirely at my own expense. The research was therefore defined initially in the terms of my professional development as an Advanced Skills Teacher; with the conditions of access to data, my right to publish, requirements of reporting and dissemination being developed within the dynamics of the research agreement bounded by academic study at University of Bath. All funds facilitating academic study, secondment and the case study work were managed independently of myself by the education department at BAE SYSTEMS, Warton, and I received no personal gain from them.

No conditions arose during my research concerning contravention or undermining of the BERA guidelines, or any undermining of the integrity of the research. While the sponsor did develop an additional interest in other possible impacts of the project, such as how and whether it may have provided positive engineering role models

## Transformation and Pedagogy

influencing career choices of youngsters, this was independent of my research into transformation and pedagogy. I consider this interest to be quite usual, being similar to other national schemes for schools that the sponsor was involved in, such as Young Engineer for Britain and CREST (Creativity In Engineering Science and Technology). It was my own decision to further develop research materials while undertaking a higher research degree, one I took for purely professional reasons.

I communicated my responsibilities and entitlements as a researcher (34) regularly with my sponsors, and with school management in the participating schools, both at the outset of the case study and at regular intervals during my research. This process was included within formal agendas at annual headteacher conferences I attended, held in Lancashire prior to and during the case study.

My competence to undertake this research (35) can be described partly from my registration as an Advanced Skills Teacher in 1997, and also from the successful application I made to University of Bath in 1999 to undertake a higher degree. During this research it was also necessary for me to take a disinterested approach to the research design, analysis and interpretation. This was achieved through employing methods of research that were fit for purpose (36), and possible risks avoided through the process of research supervision provided at University of Bath. This strategy for the research was agreed at the outset, being subsequently discussed and agreed both with the sponsors and the schools involved at the time of case study planning and implementation.

Within this thesis I have also communicated the context and boundaries of my chosen methods, and the theories and philosophies of the research I developed. These deal with the extent to which data collection, analysis technique and the inferences drawn from my findings, were reliable, valid and generalisable (37).

My right to publish the research findings under my own name is that considered the norm for sponsored research, and was discussed at the time of its approval (39). I have made every effort to ensure that the manner of communicating my findings, and their practical significance, is communicated in a clear, straightforward manner and in language judged to be appropriate for my intended audience (41).

3. Ways in which responsibilities to the community of educational researchers were recognised, including conduct and methods used (43-46).

These have been addressed throughout the case study, subsequent analysis and formulation of research ideas. I have endeavoured to maintain the highest standards of conduct in my work with the people involved, and have made my data methods amenable to reasonable scrutiny. I believe this process contributed to the community spirit of critical analysis and constructive criticism that generates improvement in practice and enhancement of knowledge.

Ethical implications of proposed research declaration were agreed and a copy of the completed MRES Declaration is available (Appendix 14).

#### **4.7 THE ANALYTICAL CATEGORIES IN RELATION TO THE RESEARCH METHODOLOGY AND THE APPROACH TO ANALYSIS AND THEORY BUILDING**

The research questions had begun to be developed during the earlier pre-case study period when I had embarked upon an extensive review of available literature. I had sought to describe motives behind introducing computers as transformational, and had raised questions about the pedagogies of teachers which were not simply linked to the availability of computers for teaching and learning but instead to the manner in which computers might change subject knowledge. In developing these interests into research pre-conceptualisations, I examined deeply the subject cultures of design & technology teachers and related these ideas to other literature on teachers' thinking, as outlined in chapter 2. I also examined literature from the historical origins of introducing computers into schools, from the early 1980s to the present time, with a view to developing some categories which could describe the perceptions of those involved. These perceptions were examined both through what writers had been saying they were trying to do, and for assumptions they seemed to be making about the value or significance of introducing computers. Some of my pre-conceptualisations therefore originated in these early categorisations that came from literature, ones that also helped form my research questions.

There seemed to have been ongoing difficulty with the pedagogical basis for introducing computers since the early period, for example lack of any distinct or changed pedagogies arising from them. I was trying to understand this phenomenon and reasoned that these introductions had failed to alter the usual or preceded ways teachers had been thinking about their teaching. My ideas concerning precedence developed from this point, initially as a very sketchy idea to handle this phenomenon, one where expected new ICT pedagogies had not arisen. I wanted to evolve some new theoretical ideas from an understanding of this phenomenon.

In pre-conceptualising ideas for this research, I had further developed my earlier thinking around ideas on precedence. Precedence served to describe possible sets of conditions which might reside behind my research questions, conditions which might be validated and further developed (or discounted all together) through further analysis.

The ways in which I further developed the concepts of precedence during the subsequent analysis and theorising can summarised here as a flow of connected (but not exact) earlier ideas:

- I had come to believe it was possible for teachers to know about something (which I described as knowledge precedents) and yet not to know about the same thing pedagogically (I found no obvious word or concept that described this idea though). This became an important idea in my research, it seemed to suggest that there was more than one way teachers knew about things. This was not quite the same thing that others had said, for example where teachers knew things in particular ways, such as psychologizing or representing them (Dewey 1902, Shulman et al. 1987). It seemed to me that introducing computers could be an example of this, for example although computers had become more plentiful in schools, teachers still did not necessarily know about them pedagogically.
- If something was not known about in any way, then it could be described as unprecedented. This idea was not especially productive for my research

though, for example it seemed to me that very few things can be actually proven to be unprecedented.

- My examination of literature on teachers' thinking had suggested that knowing about something pedagogically could be defined by the capacity to transform that knowing, for example through representing it to learners (Shulman et al 1987). This argument suggested that transformation in some way defines the idea of pedagogically knowing, a definition I had translated as the capacity to facilitate transfer from one form of knowledge or understanding to another. A transformation of pedagogy would perhaps need to be expressed in ways related to this idea.
- It seemed to have become a 'given' that computers imply changed pedagogy or representations by teachers, and were therefore known pedagogically to them. In fact, despite decades of introductions and transition of national emphasis away from discovery toward embedding, this did not seem to be the case yet.
- In the situated context of the case study, not knowing computers pedagogically had seemed to result in industrial manufacturing not being represented in design & technology subject knowledge, a significant failure that could be of national significance.
- I felt it might be possible to observe processes where teachers did develop their knowledge of computers into knowing them pedagogically, for example through the ways industrial manufacturing would be integral in case study and new design & technology activity.
- I wanted to contribute to development of new concepts and theory concerning teachers' practices, theories and beliefs with computers. This would involve carefully examining what teachers were saying about their subject knowledge during the qualitative case study situation, and developing ideas and meanings through my research questions.

### **4.7.1 Management of the qualitative data.**

In the early stages of developing my research pre-conceptualisations through the case study data, I found that I had to also develop ways of managing the literature

available to be reviewed. In the early stages, before my research questions had crystallised, I developed categories for placing literature in to see if the idea of transformation could be a useful research idea, or could be traced in any way in these writings. As already mentioned in chapter 3, these categories had a polar character, comprising 'transformation' at one extreme and 'conservation' at the other. A mid category, of 'reformation' was trialled, which became a neutral category that I used for placing literature displaying no strong assumptions in favour or against the idea that computer use might be transformational. I also included in this review of literature, texts which were non-educational and that had originated from business and industry or industrial manufacturing. This exercise served only as a means to examine assumptions behind writings. The approach was not as an exact science, but rather became a means of comparing different standpoints of other writers in relation to kinds of transformation thought, or predicted to arise from computer use in education, either overtly stated or implied. Reflecting on these early categorisations helped me to shape concepts that would later aid the analysis of qualitative research data. I also categorised this literature in terms of broad historical emphasis, suggesting that there had been an earlier emphasis on discovering with computers which had evolved into a greater concern with embedding practice with them. This was partly to help consider different ways teachers' pedagogy with computers and ICT might have been facilitated. This new line of thinking became represented in the design of my research questions.

The research questions were partly informed by this early categorisation of literature, and partly influenced by discussions with teachers who had expressed interest in participating in the project before it began. These discussions were important, not only for helping the data and findings to be grounded in some of the actual concerns of teachers, but also in helping me to develop certain focussing themes, which will be examined later.

In order to make the case study data amenable to analysis, it was necessary to set up certain indexing and retrieval systems. This process involved creative work using a NUDIST retrieval system, in order that my analysis could be developed.

### **4.7.2 Indexing the data.**

Beginning by working from the earlier categorisations mentioned, I searched the data for themes which I developed using further descriptive and analytical categories. This approach to indexing the data involved searching the transcripts for all mention of these categories to allow me to get a handle on the data.

### **4.7.3 Developing the conceptual categories.**

I developed certain conceptual categories from the earlier indexing process. These were aimed at teasing out of the qualitative data, certain deeper relationships relating to the research questions. As such they were more challenging in their character, being also grounded in the theoretical perspectives brought to the study. This approach helped me to marshal the data, enabling it to address the research questions from different angles.

### **4.7.4 Analytic categories developed from the data.**

The approach to indexing and retrieval was designed to allow me to link the interview data to categories, the amount of text needing to be indexed to locate it in a particular category being a matter of interpretation (Mason 1994, 91-2). I developed my indexing using NVivo in the computer package, NUDIST. This allowed the identification of categories and associated text in ways that were as flexible and as straightforward as possible.

Using this approach I developed starting points for various types of analysis, my categories providing an opportunity for analytical thinking and ways into the data, rather than analytical end products. Pictures were built up of the data, while maintaining the context of what had been said in order to maintain validity for my analytical claims. More detail of this process is explained later in this chapter in the context of using the NUDIST software package.

The categories used were based on a common start-point, which is illustrated in chapter 5, fig. 10. These common categories were designed as start points to help explore the case study, develop theory from it and to test the theory to see if it could



## Transformation and Pedagogy

be generalised and made meaningful to other practitioners. The initial categories in this start-model were:

- Collaborative learning.
- Influence of industry.
- Working with other people.
- Computer aided design.
- Using computers.
- Classroom practice.

The ways these categories were related to broad themes, ones residing behind the design of questions, was also mapped and is detailed in chapter 5. I examined the data in different ways, carrying out in-depth analysis of the data using NVivo and considering carefully how this:

- Was describing teachers' methods.
- Was describing how interviewees encountered any possible transformation-precedents and new practices as the case study progressed.
- Was describing interviewees' perceptions of the role and usefulness of the ICT used.
- Was describing interviewees' views and perceptions of how the work that was expected and carried out during the case study reinforced, developed or changed their thinking.

This approach allowed me to draw the materials into units of analysis for the research, while looking for convergence and triangulation by comparing the views of interviewees who were active during the project.

In arriving at conclusions to help address the research questions I considered:

- On the basis of the data so far, what were the credible or likely explanations for what seemed to be going on with teachers' pedagogy?
- What was the full range of influences at work?

- What made the processes work in the ways that they did?

As the analysis developed, I evolved a number of flow logic diagrams in order to help me consider what was possible, which are presented in this thesis as progressive iterations. In combining the case study data with my earlier pre-conceptualisations, I proposed certain new concepts, which are examined in chapter 5. These concepts were not asked about directly though, but were instead woven into the themes from which the questions were designed. These helped to open up processes of pedagogical change posed by the case study and to build new understanding of them. This approach was consistent with the ideas of Strauss and Corbin, (1990, 40), who stress the need for a fluid and skilful, rather than rigid, application of research procedures together with being sensitive to meaning without forcing an explanation upon the data.

Advice was taken on the approach to theory building from the data (Strauss & Corbin 1998, 15-25), which had emphasised:

1. Building (rather than testing) a theory.
2. Using analytic tools for handling the mass of raw data from the project.
3. Considering alternative meanings of phenomena observed during the project.
4. Being systematic and creative at the same time.
5. Identifying, developing and relating any concepts that are the building blocks of theory.

I was attempting to develop theory incorporating aspects of conceptual ordering in relation to what the case study data were saying, with some explicitly stated dimensions.

### **4.8 THE USES OF NVIVO**

My decision to use the computer as a tool to help manage data requires early qualification, for two main reasons. Firstly there has been the advice on caution about claims for the role of the computer in qualitative analysis and data integration (Mason 1994, 109). It is clear that the computer cannot substitute for imagination in the

## Transformation and Pedagogy

analysis of data (Bryman and Burgess 1994, 221). Secondly, while the possibility that the computer can help to provide transformational precedents that influence pedagogy is a consideration of my research, the idea that the computer transforms the analysis of research data is not. In fact, where others have hinted of a transformational role for the computer in data analysis (Richards & Richards 1994, 165), in practice this seems to mean only that a certain flexibility may be brought to methods of handling data or the routines of analysis that can be supported by the computer. It does not mean that the computer is acting as interpreter of data, but rather that it may more easily facilitate certain routines that are useful to the researcher in developing understanding of relationships in the data. Even this is not an unqualified benefit though, for example early experience in the development of NUDIST software warned against the ease with which code-and-retrieve was facilitated by the computer could easily be allowed to take over creative analysis and lead to an unhelpful proliferation (Richards and Richards 1994, 168).

In my case, although the computer did help with indexing and retrieval aspects of the qualitative data management, it was not used to perform the creative and intellectual tasks of deciding categories, types of data being investigated, meaningful comparisons, or generally appropriate research questions and propositions which I used to interrogate data.

The rationale for adopting the computer to help manage the research data was based on other factors needing mention. For example, I was uprooted from where I lived for two days each week over a two-year period, travelling to Warton in Lancashire and then returning to my home in Wiltshire where I continued with a job as a classroom practitioner. As I did not stay at home to do my research, there was a danger of a dislocation from both kinds of work. Although I could rehearse or try out certain ideas with my own classes, there were inevitably differences of practice I encountered in other schools to be considered. I needed to learn how to become a fieldworker, analyst and author in this process. This situation was complex and I regarded the computer as a tool that could help me to manage my time.

The decision to enlist computerised means in organising the data was therefore taken in the light of my circumstances, where I had:

## Transformation and Pedagogy

- Long-term participant experience as a teacher of design & technology in secondary schools.
- Limitations on my time for recording, interpreting and writing up my materials.
- Specific relationships with the people who were the subject of my study.
- Become a principle collector and walking archive for the case study.
- To achieve objectivity in what became an open-ended approach to the full range of information and people involved in the case study.

At the end of the case study I was faced with varied data derived from working with different schools and groups of people at BAE SYSTEMS and, while I had evolved certain ideas on transformation and pedagogy by this time, the more refined research thinking could not be developed until much later.

It was in these contexts that the computer helped me with detail of the interview discussions. Having visited a school or a BAE factory and made taped recordings of the dialogue with interviewees, I would replay and enter this as text using my laptop on the evening of the same day that the interview had taken place. I therefore also had good recall of any particular aspects or context relating to the interview and could add notes accordingly to help with later interpretation. This assisted my ability to interpret data, based upon a long-term participation with those involved, for example in identifying overlaps, their location and cross-references.

The computer certainly eased certain aspects of the workload, but it did not provide me with my discovery of certain emergent themes, notably those concerning precedence and the differences I was forming between such ideas as usually preceded, preceded, un-preceded and unprecedented. These can therefore be said to have emerged gradually during the fieldwork represented by the case study, and the years of subsequent reflection.

During the analysis of data, the computer helped me in looking for classifications that might be used as organising principles, ones that were somehow also borne out by

## Transformation and Pedagogy

observations during the case study. While the computer did help me in searching for clues in the text of the interviews, their selection in the writing up was grounded in the relevant historical and school contexts of the introductions of computers that had taken place when compared with those situated within the particular perspectives that had informed the design of the case study.

In addition to the dual work roles I was managing as researcher and practitioner, there were issues of sophistication in my data that I felt suited an ease of indexing, ones helped by the computer and achieved through code and retrieval methods and the uses of index categories at nodes to help develop coding for Grounded Theory. This seems to have been the main innovation that the development of NUDIST originally intended (Richards and Richards 1994, 168), an approach that allowed me to experiment in linking theory with my data. Another sophistication had come from my idea that, while the broader research community dealing with the introductions of computers had generated certain standard questions such as those relating to improvement or certain kinds of impact, I was unsure that these were actually the questions that needed to be answered in relation to teachers' pedagogy. I was interested in whether my research could reveal other kinds of questions, ones for which there may have been an absence of comparable studies with which to inform an analysis.

NVivo therefore provided me with an administrative technique that helped in forming intellectual judgements bound up in the analysis. This involved the pulling together of categorized data and locating it at the indexing stage. It allowed me to label categories with an address, allowing it to be easily turned back to the interview context. Once category files were finished, much intellectual work had to be done in following up, but the categories helped to provide building blocks for my analysis. Long after analysis, NVivo made it possible to pull out files on any categorized theme, to germinate further analytical ideas and to find other ways to understand it.

The resultant web of meaning could also become more complex and confident than manual means would have supported, the knowledge of the data far deeper, the researcher equipped for interrogating results in ways not possible in the filing cabinet (Richards and Richards 1994, 170).

Advice was taken on dealing with the potential volume, diversity and unstructured nature of the qualitative data yielded by the case study (Fielding and Lee 1998, 56-59), while allowing for the dynamic nature of the research environment and of the need to negotiate the place of computer aided analysis. The decision to use the computer as an analytic tool, therefore centred on two main reasons:

1. To help facilitate the task of *data-management*

Because there are difficulties in working qualitative data, such as those already mentioned as inherent to qualitative data, mechanizing certain mechanical difficulties would likely benefit time, efficiency and allow more thorough analysis (Tesch 1990, 107). In other words to avoid the data management inhibiting the analytic process.

2. To provide a potentiality for *extending the capabilities of the researcher*.

In other words, to provide analytic possibilities difficult to accomplish by more traditional methods, for example replication by other researchers is made possible because the computer can allow the researcher to be clear about what is being done and allows a log or trail of analytic procedures to be kept.

Using NVivo was to help with the building of systematic relationships within the data, as in the light of arguments by others (Creswell 1998, 157-163), that NUD.IST supports Grounded Theory research through the catching and interrogating of meanings emergent from data.

Once the transcripts of interviews had been imported into NVivo, work began on categorizing it as data. The early stages of categorising involved close examination and linking of text to ideas and reflections concerning transformation and pedagogy, as understood at that time in relation to the research questions. These ideas were initially developed as tree diagrams, representing possible 'flows' that might form the basis for later theory building and help develop understandings (Strauss and Corbin 1998, 12-14). At this stage these trees allowed me to:

- Be open to multiple possibilities from the data.

## Transformation and Pedagogy

- Generate different options for explaining the data.
- Explore various possibilities before choosing one.
- Make use of multiple avenues of expression to stimulate thinking.
- Use non-linear forms of thinking in order to better understand the data.

The linking process was refined by attaching labels to points in the tree structure and linking these to detail in the data on what people had been saying. These labels became the categories of ideas, concepts, people and things that formed the next stage of the NVivo analysis. This allowed ideas arising from the data to be flexibly managed and for the categories to be gradually connected. This connecting of categories represented a later stage in the analysis and allowed sets of data to be presented that seemed to be dealing with ideas that had certain common properties. Further modelling was still possible at this stage and the justification for placing data in sets was achieved through asking questions, reflection and the search for corroborating evidence. Ideas from the literature review were also used to help make sense of the data.

## **4.9 CONCLUSIONS**

The analytical process designed for the research was to allow ways in which data would be analysed to increase understanding of teacher's pedagogies when influenced by pedagogical precedence. The research methods used were chosen to help meet the challenge of analysing certain phenomena that have been argued to be associated with transformation in the context of using computers, in this case situated in design & technology teaching. This analysis was matched to new ideas on transformation and pedagogy that were also being presented so that a contribution could be made to understanding the phenomenon of pedagogical precedence presented to teachers by computers and ICT.

## **5. ANALYSIS OF THE FINDINGS**

### **5.1 INTRODUCTION**

The analysis of case study data is examined next, including ways codes were introduced, the rationale behind coding and how this was aggregated. This selection from data can also be illustrated by more developed iteration of causal flow overleaf at fig. 7, which was a strategy I used to suggest ideas for selecting data, ones to be confirmed or otherwise by considering what the data were telling me:

Fig. 7: framework for analysing transformation, second iteration.

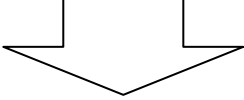
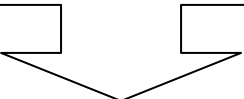
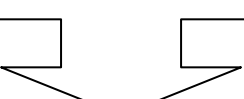
<div style="border: 1px solid black; padding: 10px; text-align: center;"> <p><b>Pre-transformation period</b> (a condition prior to transformation)</p>  </div>	<p>The usual preceded pedagogies of teachers meant that design &amp; technology products relied mostly upon individual pupils expressing different ideas and proposals as an iterative process. Products were usually represented through sketches and drawings and could be examined and compared to identify a possible solution to the problem of passenger plane design.</p>
<div style="border: 1px solid black; padding: 10px; text-align: center;"> <p><b>Transference period</b> (new formations appear)</p>  </div>	<p>The teachers and BAE engineers created a new situation where the problem of externalising different ideas for passenger planes, as well as allowing them to be reviewed and evaluated, now depended upon an electronic product definition. The situation presented a possible transference for pupils from the form of one mode of working (developing more individualised ideas and designs on paper) to another form (responding to product situations displayed via the computer)</p>
<div style="border: 1px solid black; padding: 10px; text-align: center;"> <p><b>Form-transfer</b> (post-transformation precedents appear)</p>  </div>	<p>As the teachers and pupils developed increased familiarity with the new situation, a form-transfer in methods used to successfully design artefacts became possible. It was a new precedent for them to be able to develop, present and evaluate their ideas for passenger planes in this way. Ideas developed via the computer were more realistic in their appearance than pupils' sketches, less tedious to produce</p>

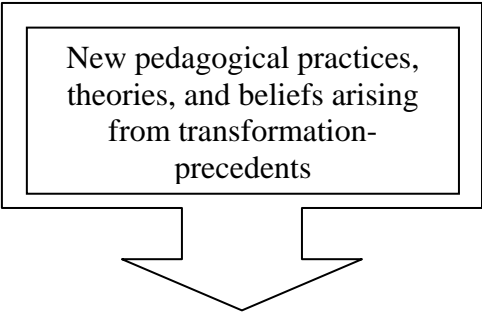

	<p>and the methods of accommodating passengers in the planes could be checked before manufacturing began. The new precedent concerned ways that design &amp; technology products were being represented by teachers for pupils.</p>
 <p>New pedagogical practices, theories, and beliefs arising from transformation-precedents</p>	<p>The form-transfer in methods used to design passenger planes challenged prior pedagogical practices, theories, and beliefs. These included the need to clarify parameters relevant to plane design at an earlier stage than before; such as size, shape and mass; and to input these as data into the computer program before designing began. Pupils' designs could now be based on more reliable information. As the project progressed, this electronic definition of the plane became fundamental to the teams of pupils in different schools who were by then working and collaborating on the same product.</p>
<p><b>Pedagogy issues</b></p>	<p>Teachers reviewed and modified methods of presenting the design of challenges and assignments to pupils in design &amp; technology. Ways for all pupils to be introduced to uses of the computer were developed. The expectations of pupils by teachers entered a new phase, for example how to deal with shared interfaces that were also being affected by other schools and pupil teams.</p>

**Fig. 7, source: author**

## 5.2 THE INTERVIEW DATA

I initially collected data by taping what was said during each interview. The choice of questions I used was determined by who was being interviewed (e.g. pupil, teacher or

engineer). I would then transcribe the spoken words and narrative into a word processor, after first replaying and listening to the tapes. This data was then imported into NVivo as Rich Text records. The resulting data bank was analysed using a variety of NVivo processes and tools.

### 5.2.1 Analysis of the questionnaires.

The interview questions had been developed with the assistance of five broad focussing themes, linked to the research questions for the groups interviewed in the case study. The interview questions (Appendix 7) reflect these five themes and focus upon possible improvement to learning that may have resulted in the opinions of the interviewees.

### 5.2.2 The reasoning behind the questions.

The interview questions were examined in ways to help develop understanding of the unknown phenomena of situated pedagogy change being examined. The detail of the experiences, feelings and judgements of people was analysed in relation to the research questions, their relationship to the five broad themes can be illustrated as follows:

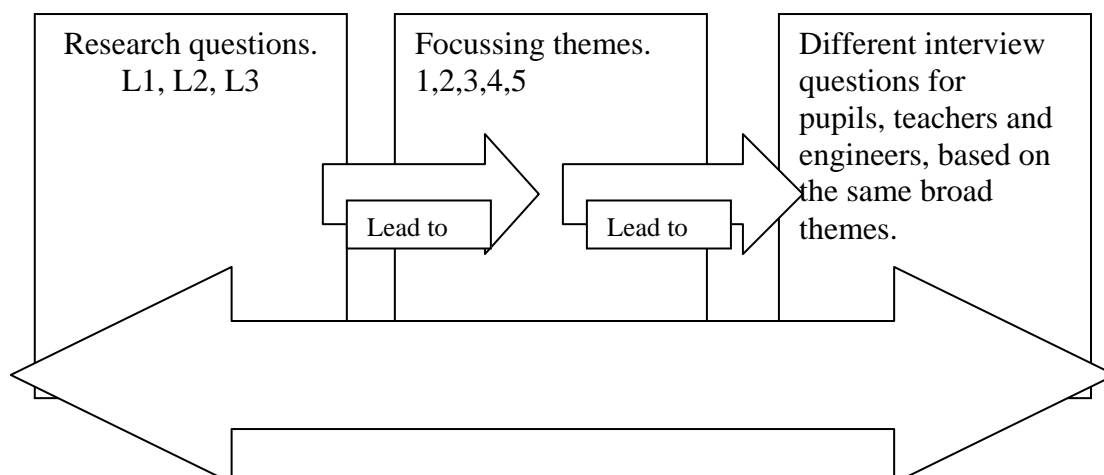

Fig. 8: diagrammatic representation of the linking between the interview questions, focusing themes and the research questions.

**NVivo analysis to build systematic relationships  
within data**

**Fig. 8, source: author**

### **5.3 ANALYSIS OF THE INTERVIEW DATA**

I used the NVivo package to help me browse the data that I had collected, gradually addressing the problem of making sense of it in the context of my research questions. Nvivo helped me to explore traces of ideas within searchable documents, as well as to develop their possible meanings. I can describe this process as one where I tentatively tried to develop varied possible meanings. These were sometimes discarded or adopted. I sought to judge the strength of an idea emerging from the data, assisted by modelling with the NVivo tools available at that time. The structuring of my data using NVivo involved the introduction of nodes, as well as the linking and coding of particular meanings that could be interpreted within both textual and memorised traces from my original interviews.

The steps taken in NVivo can be summarised as follows:

- Inputting the data in RTF format to QSR NUD\*IST Vivo software.
- Finding a focus in the early stages of analysis.
- Managing the data into categories, using tree and free nodes.
- Reading and annotating the data, especially where teachers seemed to be adapting or changing.
- Categorising the data.
- Linking the data.
- Connecting categories.

The main aim here was to find what people were saying about their experiences. Nodes were used as containers for categories and coding to help describe particular concepts and ideas that mattered to the project, and were organised hierarchically into

trees. The coding involved placing references to passages in the text records, browsing the data, rethinking, recoding and asking questions about the categories in searches.

### **5.3.1 The codes and their aggregation.**

To distinguish transformational data from other kinds of data, three attributes were created, allowing values to represent transformation in the context of the teachers and their sense of transformation.

These attributes were entitled:

- Conservation
- Reformation
- Transformation

The origins of these attributes has already been mentioned during the literature review in chapter 3, and by this stage in the research they were helping data to be allocated a particular attribute depending on its bearing with certain focussing categories. These focussing categories had been partly developed from issues and concerns of the teachers involved in the case study, as they had expressed themselves at the pre-case-study meeting on 15<sup>th</sup> September 1998. Including these issues was intended as a strategy to help ensure that the interpretation of data was also grounded in the expressed concerns and pre-case study ideas of teachers. The categories took account of teachers' spoken views on:

- What teachers can achieve in their time.
- What expertises teachers need.
- Working beyond National Curriculum
- Beliefs and values.
- Industry methods & school methods.
- Dependence on others.
- Accountability to wider team members.

## Transformation and Pedagogy

- Video conferencing and email.
- Managing timings between schools.
- Sustaining the project.

Using the focussing categories, a choice from the three attributes could be allocated to instances in the text. The basis for allocating attributes was through judgements and using pole-positions for transformation and for conservation. A middle category, 'reformation', was used as an attribute for data that did not seem strongly to favour either of these poles, or might conform more to my L2 research sub-question in not being transformation. Attribute allocation required judgements about whether the data represented some or all of the following, shown overleaf:



3. NVivo coding was also done at this stage, for example where interviewees seemed to be using an NVivo concept in their dialogue.

### **5.3.2 The NVivo models.**

The modelling for the case study used categories, each with 'children', on poles and an axis. These models were built around a common format, which is illustrated later in this section at fig. 10. On using these categories for coding, I realised that there needed to be a means of linking up the different categories and concepts as they are identified. The categories were related using a set of 'issues affecting teachers', the set working as a kind of system. Through applying the 'issues affecting teachers' to the text, the data could be cross-referenced into the conservation and transformation categories to provide the NVivo patterns.

The NVivo patterns were developed further into trees and nodes. While concepts were allowed to emerge during the analysis of the data, care was taken to avoid missing important issues and in looking for the right things in the data. Categories were reviewed during this process to check that the categories were still sufficient and decide whether others needed to be developed or added.

### **5.3.3 How I dealt with the positive framing of the interview questions.**

Some of the data extracts fit most or all of the concepts within the higher-level categories (for example, nearly all of the transformational ones). This only happens a few times, but when it does it seems significant. For example, when the term 'interface freezing' is used by interviewees it seems to fit the higher level transformation concepts, rather than the conservational ones. This may have been because, while the interfaces of a product are normally defined personally in more usual design & technology and are more under personal control, within the Eurocollaborator the interfaces of the collaborative product (the entire plane model and its relationship with other pupils and teachers in other schools) are 'frozen' to represent the boundaries between one schools' component and that of another. For it to be possible to assemble the plane at all, from each school's separately

## Transformation and Pedagogy

manufactured different components, these interfaces had taken on an unchangeable quality which was defined electronically rather than personally and labelled as 'frozen'. The instances where 'interface-freezing' was used tended to match the six categories on the transformational pole of the NVivo categories diagram, fig. 9. The idea of 'interface freezing', in the Eurocollaborator sense, may have represented a new design & technology practice and may also be related to a pedagogy change.

Some of the data extracts could be argued to fit more than one class of category, for example it is possible for an extract to mean something within both the transformational and conservational higher order categories. The idea of 'rubbing off' could be argued to work with category 3 on both poles in fig. 9, for example that better understanding could result from first-hand contact of either transformational or conservational approaches to work. In such cases an interpretation was necessary, for example careful analysis of the interview transcripts with teachers who used this expression tended to suggest they meant the rubbing off of new practices, meaning a change toward the transformational categories.

Sometimes a teacher, whose data suggested a consistently transformational mode of thinking or behaving, becomes apparently conservational in the next sentence. For example, in one NVivo Document Coding Report 17th May, (Appendix 11) a teacher from a school in the South East makes statements that are easy to attribute to the transformational categories, such as where he is saying that he and his pupils achieved high levels of collaboration through not making the mistake of using 'prototype methods to do their modelling' (while other teams in fact had made this mistake), and where his team's approach had shown that, 'on the day of the consortium meeting it (the plane) actually looked pretty much as we expected it to look like..'. But at passage 5 of 9, para. 192 he said 'but to be honest there is no great advantage to them working or not working (as distributed student teams) they either pleased or they didn't please me, that was their end goal.' This later comment could be interpreted to mean that he was teaching the group from a broadly unchanged pedagogical position.

In thinking deeply about this duplex phenomena, I felt it was as though most of the teachers assumed either or both modes of thinking at certain times, or that they slipped from one mode to another. An ideal would have been to supplement what the



teachers were saying in the interviews (conducted during the project), with some post-project data. This could have helped to judge how effective the project has been in influencing pedagogy beyond the case study, but this idea was abandoned due to limitations on further research resources and the continued availability of teachers who were involved in the project.

### **5.4 WHAT WAS SAID DURING THE INTERVIEWS AND WHAT WAS SELECTED AS ESPECIALLY RELEVANT TO THE RESEARCH QUESTIONS**

While I had defined the basic research questions for transformation and pedagogy, the peculiar conditions of the case study participants provided situations within which I could develop data sets and my emerging analysis. These conditions also influenced the ways Grounded Theory was used, leading me to an unusual treatment of data, one using unorthodox ideas that were never the less drawn from the traditions of Grounded Theory. At this point some clarification of what I did, in descriptive terms, as a conflation of what I did, and why I did not use what might be typically expected in Grounded Theory is mentioned:

It may seem that I placed minimal emphasis on using Grounded Theory to organise findings as causal phenomena in this research. I was dealing with areas of conceptual difficulty in the chosen research field to that point. Some of this difficulty had to be overcome before pedagogical transformation could be adequately described. Thirty years or so of introducing computers to schools has led (as yet) to little agreement on what is actually meant by pedagogical transformation. In the absence of such consensus I had to find new ways to identify and organise possible causal phenomena of pedagogical transformation. These difficulties led me to postulate new terms, such as that of pedagogical precedence illustrated in fig. 3. Contextual factors of transformation were described in terms derived from the particular case study situation.

Both textual and conceptual level procedures I used within NVivo were efficient and firmly based on the principles of Grounded Theory generation (Fielding and Lee

## Transformation and Pedagogy

1998). However, there were particular challenges for the higher conceptual level in my case, which, perhaps, rendered my Grounded Theory approach atypical.

To briefly recap, the research has aimed to illuminate the evolution of teachers' thought in relation to transformation and pedagogy, facilitated by ICT. The focus was on what is meant by pedagogical transformation, rather than on attempting to predict it. Until quite recently, little attempt has been made to define transformation in relation to pedagogy and ICT. This led me to give more priority to developing clarification of meanings for pedagogical transformation, rather than dwelling on particular issues for individual teachers, and this affected ways I analysed and brought data together. This also meant that I have not emphasised granular quantitative reporting of individual teachers' pedagogical development, such as might be reported through standard tables with codes against a number of sources and frequency of mentions. Instead the sense of how my judgements arose, as well as the systematic exploration of data for reliability criteria to be met, was shaped by a holistic interpretation of pedagogical transformation. This drew upon a treatment of data transversely and via multiple teachers, rather than a dendrology of individual teachers' pedagogy.

However, my treatment of the data was systematic though, for example the transversal relationships between data had to be developed in relation to the schedule of research phases described in fig 2. This schedule was in turn influenced by different phases of the evolving Electronic Product Definition around which the case study project, and therefore the experiences of pedagogical transformation of participating teachers, was organised. This resulted in certain research challenges, arising from both the nature of the research area and from the particular context within which I had chosen to source and develop the new research ideas. Response to these challenges was not straightforward, and sometimes made orthodox treatment of the research data inappropriate.

To exemplify this, the influence of the prior failure of UK design & technology subject teaching to represent industrial manufacturing is briefly examined next. The range of experiences provided by the Eurocollaborator project was carefully developed over the two years of the project to allow teachers to evolve more

## Transformation and Pedagogy

appropriate manufacturing pedagogies, a process that involved considerable regional and national detailed planning. The manufacturing consciousness, and confidence, of teachers was found to be something gradually coaxed and evolved rather than taken-for-granted, and in practice was achieved through a gradual scaling up of the manufacturing demands upon participants over the two-year period. In fact, as already explained in chapter 2, manufacturing methodologies (which treated personal intervention as a source of inaccuracy to be eliminated) could be perceived as at odds, or in conflict, with more usual design & technology pedagogies (which treated personal intervention as a fundamental aspect of creativity). The desired pedagogical transformation of the project could therefore also be considered, by some, as at best risky, or at worst, alien and in opposition to accepted design and technology practice. It was found that time had to be allowed for teachers to: a) gradually explore manufacturing pedagogies and b) subsequently abandon these pedagogies at the end of the project. Therefore, I was faced with evolving less conventional modes of data collection and analysis that could take account of this unusual research situation. The point of mentioning this abandonment is to clarify why it became difficult to treat pedagogical transformation in perhaps more usual research ways, through, for example, the idea that pedagogical transformation in the case study was not only unprecedented but also had a reversible quality for teachers. This serves to make the point that I felt unable to develop the analysis of teachers' pedagogies in the manner of a dendrology. The manufacturing pedagogies involved lacked permanence that might enable their examination as fixed or individual layers within teachers' pedagogical knowledge. However, this did not mean that the pedagogical transformation I was examining was similarly lacking in permanence. This was because my research was introducing new meaning to the idea of pedagogical reasoning, rather than describing pedagogy as a product that might just be expedited by ICT. This idea followed my argument that knowing computers and ICT pedagogically was probably distinct from knowing them in other ways.

In applying NVivo to this situation, I had begun textual level analysis by labelling and categorising phenomena in the data to arrive at basic building blocks for the analysis of pedagogical transformation. This step was similar to open coding in Grounded Theory. I made sense of this labelling and categorisation by drawing upon a pre-theorising framework of ideas, based upon the notion of precedence. Although the

## Transformation and Pedagogy

textual level analysis could be achieved via line-by-line analysis of potential indicators, allowing me to accumulate basic units for my analysis, I had also to bear in mind the duality of the research phenomenon in question: namely, of both ‘pedagogy change’, and ‘pedagogy change that might also be transformation’. My conceptual labels therefore needed to be constrained within some parameters that suggested transformation, while making a pedagogical sense within the particular characteristics of the project that the interviewees were engaged in.

The need for the further higher categorising level recommended in Grounded Theory (Corbin and Strauss 1990, 7), was then addressed by comparing data across different case study consortia. This involved the researcher in considerable travel to visit particular schools in different consortia at key points in the project, and introduced a peculiarity to this case study, which should be explained. The case study participants in different consortia were working within a project that was new, rather than typical in their experience. I addressed this challenge by ensuring that at each stage of the analysis I depicted an evolving set of research conclusions via flow-logic diagrams, allowing different possible iterations of a research flow logic to be examined. This helped to portray ways in which categories developed, providing a higher level of abstraction. However, the higher-level abstraction was dealing with certain peculiarities of pedagogical transformation across distributed school sites, rather than from within more conventional classrooms. Some implications of this for the theoretical ideas I developed on precedence are illustrated in the table below.

In Grounded Theory, theories emerge from the data. However I had sought to show how the literature in my research already suggested that distinct models of pedagogical transformation could be involved, that had yet to be articulated in terms of the precedence suggested in my pre-theorising. My high level categorisation was therefore largely driven by literature, while also recognising the need to more clearly understand the possible role of ICT in transforming teachers’ pedagogy. Subsequently I developed these ideas from the further analysis of research data to extend and sharpen the emerging theory, filling in categories that needed further refinement.

While I had defined the basic research questions for transformation and pedagogy, the peculiar conditions of the case study participants provided situations within which I

could develop data sets and my emerging analysis. These conditions also influenced the ways Grounded Theory was used.

In clarification of these points, I have included the table below to make the peculiar research conditions more fully explicit:

<b>Challenges in using Grounded Theory to address pedagogical transformation</b>	
<p>This table illustrates the challenges I encountered while researching pedagogically transformational phenomena. It was the unusual sense of these data, illustrated and contrasted in the right hand column, that influenced my interpretation of Grounded Theory.</p>	
<b>Usual</b>	<b>Unusual</b>
<p>Scale of case study activity may be researcher-manageable, subject to rerunning and repeating to establish and hone consistency of detail.</p>	<p>Case study phenomena were mobile and time-limited. Scale of case study was unconstrained by convention, or what is usual in the situation. The project was also very large in scale and extended, being not bounded by single classrooms or usual teachers-class relationships, and with stages tending to be un-iterative or un-repeatable once particular moments had passed into history.</p>
<p>The main research phenomenon may be fully describable in the first person, for example being based upon the personal experience of an individual interviewee in a specific physical classroom location.</p>	<p>The main research phenomenon was only intelligible in a collectivised sense. For example, each of the six planes was being manufactured by several schools and by many individuals who were not bounded by a particular classroom context as such. The usual teacher-pupil relationships had been temporarily banished, for the purposes of the case study, but this temporary relationship could only be</p>

	examined as a series of samples. The interviews were dealing with finite life-stages in the project, which passed by.
The research phenomenon may be located within concepts that have a more generally accepted meaning.	The research phenomenon was located within ambiguous and unformed concepts such as ‘transformation’, ones that were never the less becoming influential of national requirements and policy. Addressing the instability of this concept, within the context of teachers’ pedagogy, became a priority.
The research phenomenon is contextualised within situations given broad pedagogical recognition, or where there was some general pedagogical consensus.	The research phenomenon dealt with a missing or unrecognised pedagogical paradigm, that of industrial manufacturing within design & technology teaching, one where a pedagogy for ICT was also required for its pedagogical instatement.
The research interviewees may be describing known or familiar territory, over which they exerted personal control.	The research interviewees were describing unknown territory, where they were less personally in control and needed to replace known pedagogical representations with new ones.
The interview schedules may be decided by the needs of the interviewer or interviewee.	Interview schedules were determined by the project design, during a three-year period of the project planning and implementation, including before and during the collaborative phases in six broad UK geographical regions.
Questions may be pre-planned and prepared to ensure clarity.	It was difficult to develop interview questions that could inform the research questions into the ill-formed concepts in this case. This meant that both had to be

	subject to change as the research progressed.
--	---

In conclusion, four points can be made to qualify this unusual treatment of data that used unorthodox ideas drawn from the traditions of Grounded Theory:

1. There were advantages to treating data more transversely, and less as a dendrology of individual teachers' pedagogical development. These allowed the examination of points of coincidence within the dialogue of different teachers interviewed, ones that were related to and influenced by common phases of the electronically defined product with which they became involved. Although teachers' pedagogies were considered individually during the interviews, the different teachers in each plane-building consortium were not in fact working in isolation, or separately from each other. Indeed, they became dependent upon one another. It is not implausible to suggest that a common product concept, represented through the ICT medium of EPD, could in fact come to be understood pedagogically in ways that were also shared by these teachers or by means of mutual reinforcement of common ideas and practices.
2. Giving more emphasis to data transversely across the plane building consortia, than individually for each teacher, could run the risk of ignoring data that did not directly concern the consortium, yet was important to the individual. This might lead to false claims about the growth of common or complimentary pedagogical knowledge. In addressing this problem I employed three kinds of strategy. Firstly, to help make judgements about the data and the context within which interviewees had spoken, I bore in mind that I was arguing for pedagogical transformation as change to the basis of teachers' pedagogical reasoning, rather than as a mere product that was in some way expedited by ICT. I made judgments here on including particular data in my analysis by looking for evidence of links between influences of the ICT in question (EPD) and pedagogical precedent (industrial manufacturing). Where these links were suggested, I felt it plausible that certain conditions arising in the case study seemed to be affecting the basis on which pedagogical decisions were being taken by teachers. Secondly, I sought to identify where these tensions were being exhibited in the data using special descriptions of precedence developed

during the pre-theorising stages of this research. The terms ‘transformation’, ‘reformation’ and ‘conservation’, to which I had attached special meanings, derived from a broad examination of literature in this field. I developed these meanings through making judgements on the orientation of varied writings on computers and transformation. I was interested in the extent to which such orientation permeated the thinking of other writers, implicitly or explicitly, or seemed to colour conclusions and findings. I also examined school based research alongside writings describing the early impact of computers on working practices in the industrial context, to help develop and broaden my ideas on transformation within different settings. Thirdly, for each of the datum selected, I considered what aspects of the project the interviewee in question had been involved with at that time, and what stage within the two-year program for the project had been reached (fig. 2). This allowed me to reflect upon particular issues and pedagogical precedents that may have been behind interviewees thinking, and to ask whether any fundamental precepts of more usual design & technology pedagogy seemed to be giving way to new ones. Additionally, in reflecting upon this work, I have drawn upon my experiences working with a broad range of UK design & technology practitioners prior to the research. For example, my joint creation of new texts and classroom materials for the Royal College of Art Schools Technology Project (1995-97) helped form a basis from which to make judgements concerning teachers’ spoken ideas, such as ways they might suggest that their prior pedagogies were being challenged or otherwise. These strategies allowed me to include data that could help to describe the growth of common or complimentary pedagogical knowledge within the case study.

3. The more usual treatment of data, where quantitative reporting of findings could be via standard tables with codes against a number of sources and frequency of mentions, could have more clearly developed the sense of how judgements arose from the systematic exploration of data. However, while this would satisfy the need for reliability criteria to be met, it was more difficult to achieve in the face of the growing lack of consensus concerning pedagogical transformation and it’s meaning as expressed in the literature.
4. Instead, approaches derived from traditions of Grounded Theory were adapted to address the identification of causal phenomena, causal factors described in



## Transformation and Pedagogy

terms of precedence, intervening variables, contextual factors and consequences. For example, causal phenomena of transformation were hypothesised and examined in terms of precedence, while contextual factors of transformation were defined in terms of teachers' prior pedagogical subject knowledge and the pedagogically new modes of collaborative work-share that the research examined.

Finally, the origins of these ideas on the transverse treatment of data were shown to have developed from the earliest stages of planning this research and have been identified with the inclusion of notes from my personal diary, appendix 4.

The data selected reflected the five focussing themes that, in turn, had been linked to the research questions. The following examples are typical of what was selected as relevant to each theme (italicised text represents quotations captured and analysed within NVivo) :

### Theme 1, The aircraft industry.

The teachers and engineers recognise that they work in different settings. Bringing the different worlds of teachers and engineers together involved a *'reconciling of operating philosophies'*. Teachers felt that they were *'rubbing shoulders with engineers'* throughout this work and that the pupils *'were able to see different sides from industry'*. In this situation a teacher described working with the engineers as *'providing a rub-off effect'*. The engineers described their strategies for influencing the work of the project in their particular schools and would sometimes use language from their own workplaces. For example, when difficulties were encountered they sometimes had to mediate between individuals in the schools to *'avoid stand-off industrial relationships'* or *'to kick someone's arse and get them into gear'*. Strategies for dealing with difficulties were linked *'to being able to find win-win solutions'*. Teachers seemed generally willing to tolerate difficulties associated with the change as *'the pay off came later'*.

### Theme 2, using computers.

## Transformation and Pedagogy

The motivation to participate in the case study was connected with a desire to improve the learning of the pupils through a deeper understanding of industrial practices where ICT is going to be used in significant ways.

The project brought about a '*lending of interesting problems*' from the engineering world to the school world. The approach was described by engineers as a '*partnering with industry*' and by teachers as quite different from '*just working in limbo and working in school*'. It was described by one teacher as '*an alternative to being stuck in the same environment all the time*' and by another as '*an alternative to bolt-on work*'. An engineer said that 'this was a *step change in the way that the schools worked*'.

### Theme 3, working with people (pupils and teachers in other schools).

Improving the learning of the pupils is bound up within the need to achieve a successful product-solution (concept airplane, collaboratively designed and manufactured). The part played by the ICTs used is mentioned in this context here.

Teachers felt that '*using the (same) software right across the board*' would be a requirement of success. An engineer described the difficulties of learning to use and adopt a new software program in the classroom (Pro/DESKTOP) as '*grinding your way through the software*'. From the teacher's point of view there were seen to be major challenges arising from having to build components that would fit exactly with other components being engineered and crafted by other pupils and teachers in other schools. The role of ICT was seen to be critical in helping to overcome this challenge and one teacher described this as '*sectioning off our product using ICT*'. During this aspect of the project engineers brought terms from engineering to describe what the schools were undertaking. It became clear that strategies have been developed in engineering industry to help manage particular challenges arising from sharing of work between distant sites (known in the industry as co-located working). All participants seemed mindful of the potential for difficulty in the project, mainly due to the critical roles of others in any successful outcome. What was meant here was that others beyond their own schools, out of reach and out of sight, would have to play critical roles or construct parts that must fit into the product-whole. Shortcomings

## Transformation and Pedagogy

here would be potentially disastrous and could totally compromise the finished product. There was concern regarding this issue in each of the schools I visited, although many welcomed this as a challenge. The dialogue of engineers springs from the coping strategies that were eventually used, many of which were ICT-based solutions: I encouraged the school teams *'to work with each other across the boundary or just outside their own school'*. It was essential for them *'to get together and talk across the interface'* because *'if communication is not crystal clear there will be problems'* as well as to *'communicate with others they are interfacing with'*. There were difficulties for the teams because *'the other members of the team were not always visible'*. When there were problems or worries here it was because *'different interpretations of what was required were bandied around'*. The engineers seemed to describe a phenomenon that they themselves experienced at times, and a coping strategy was to move beyond the problem using the medium of ICT..... *'a critical point is when the interfaces are frozen and there is no longer any need for collaboration'*. The ICT *'is helping the ideas to join up'* and allows the pupils to *'work to exactly the same design, to the exact same templates'*. A goal of this work is *'using interface specifications and sizes to communicate with others they are interfacing with'*..... *'the pupils were able to take that on board.'*

### Theme 4, computer aided design.

During the case study the participants encountered new experiences, which may be described as transformational in their nature. These were bound up with the role of ICT as they perceived it, specifically the extent to which ICT may change everything rather than being just something to learn. Here the ICT came to be regarded as an enabling tool that could help overcome difficulty or simplify complexity demanded by the product. Teachers often exhibited pedagogy phenomena at these times.

Engineers felt that the project was innovative and *'pretty much stand alone'* when compared with their perception of other school work. The substance of the innovation is described in various ways by those involved though. There were some difficulties to begin with, due to radical departure from normal practices in school. Because the project was so different to 'normal' school work, many schools found *'fitting the project in or around the school syllabus'* to be a problem initially. In the early stages

## Transformation and Pedagogy

of the work *'anything went'* and pupils could be *'starting up the wrong alley'* or as one engineer put it *'they were just waiting to be spoon fed'*. But after some time *'the pupils really latched on'*. One team in a particular school experienced technical problems and *'were out for several months at the beginning'*. Another worried about the role and progress of other teams in other schools involved with their product and felt *'they were the only ones in step'*. Some engineers were unsure of how well the teachers transferred their training and experiences of the software into their classrooms. They described how some pupils began *'overtaking the teacher's knowledge to become wizards'*. The project did seem to exert pressures upon the participants at various points, especially when things didn't go according to plan or when critical deadlines loomed up. Attitudes to such problems varied according to the beholders: a teacher said that *'there was hair-tearing out and panic when things did not go well'* while an engineer described the same problem as *'making an excellent error'* because he felt that the participants had learned something very important from the situation. One teacher described final assembly, after 18 months of work, as *'basically a last minute jammit together'*. The teachers are often found praising the virtues of teamwork and the benefits to pupils of working collaboratively or co-operatively to solve problems. A good strategy for dealing with problems was *'we would all pull together and talk about it'* while *'with more heads involved'* new qualities were brought to the learning of pupils. An engineer pointed out that pupils began to work well *'when someone else's name was in front'* of a particular component of the product. Limits were drawn and imposed upon the collaborations at various stages, as either circumstances or needs dictated. One engineer explained that airplane engineers are often working away from the collaboration, *'there are often times in industry when we are not collaborating just working on our own without being disturbed' .....*, because *'if you have all of the answers there is little point in talking to one another beyond that point'*.

In contrast to this idea that engineering collaboration may be more reduced to the observance of contractually agreed and defined interfaces, a complimentary view from an engineer was expressed to describe the importance of engineers not working in isolation though.... *'without being clear about where they are going in industry, they will just stick to the drawing and work to the last minute'*.

Theme 5, different ways of working learned during the project.

The learning of the pupils is described in various ways depending upon viewpoint. In many cases this learning was said to be different to the norm of school work.

Teachers wanted to avoid '*boxing them (pupils) into a particular route*'. An engineer felt '*it was the methods, not the content that made the work different*'. Some of the differences arose from the need to work collaboratively across sites. An engineer felt that this was where '*different schools were often rubbing up against each other*' or where different engineers '*were often rubbing up against each other on different areas of the work*'.

**5.4.1 Summary of what was found out in relation to codes used and ways they were aggregated.**

The use of NVivo analysis in the research has been extensive, based mainly on the transcribed data from taped interviews with teachers, engineers and with pupils' data used to check that teaching was actually different to the usually preceded. The NVivo analysis also was continued after the case study was wound up and has been re-visited during the subsequent period of research and writing-up between end of 2000 and of 2006.

As already mentioned, although data was collected for pupils and engineers as well as teachers, its main purpose in this summary of the analysis is to show how teachers seemed to be dealing with newly emerging precedents during the case study. This idea is developed through references to comments in the data which also provide a final refinement to the transformation and pedagogy flow-logic diagram at the end of this chapter, fig. 13, third iteration.

The case study data were examined in varied ways, each involving improved or further refined ways of interrogating and interpreting the available data. Each approach was developed from a similar start model, reflecting themes illustrated at fig. 10 overleaf:

Fig. 10, the common NVivo model.

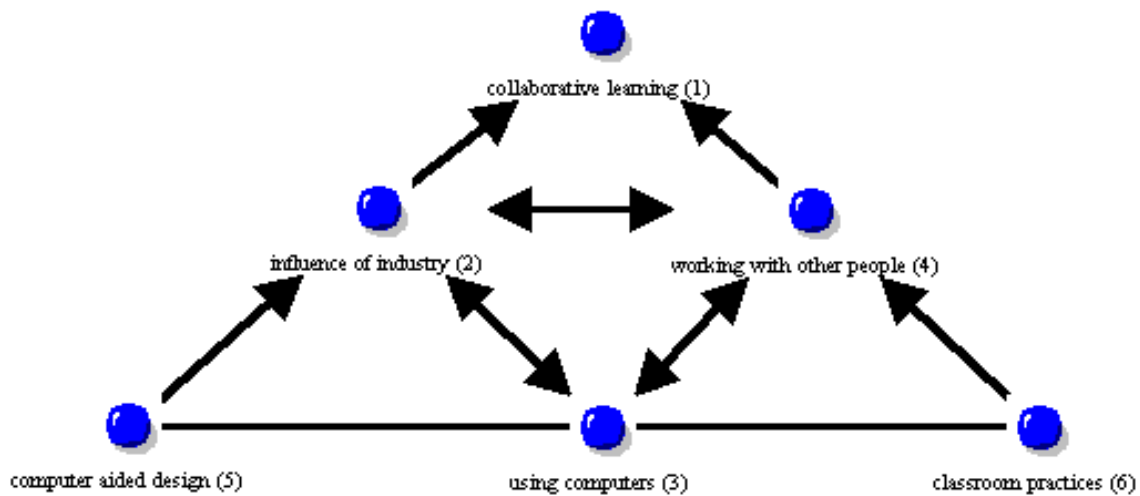

**Fig. 10, source: author.**

Because I had six nodes in the fig. 10 common NVivo model, and only five broad focusing themes related to the research questions and the case study interviews, the correspondence between the five broad themes and the questions is mapped for clarification as follows:

Fig. 11: map of correspondence between broad themes, NVivo nodes and questions.

<b>Broad themes used to develop interview questions</b>	<b>NVivo nodes</b>
<i>Theme 1, the aircraft industry.</i>	Node 2. Influence of industry. Node 4. Working with other people. Node 5. Computer Aided Design. Node 3. Using computers.

<i>Theme 2, using computers.</i>	Node 2. Influence of industry. Node 4. Working with other people. Node 5. Computer Aided Design. Node 3. Using computers. Node 6. Classroom practice.
<i>Theme 3, working with people, e.g. pupils or teachers in other schools.</i>	Node 1. Collaborative learning. Node 4. Working with other people. Node 5. Computer Aided Design. Node 6. Classroom practice.
<i>Theme 4, Computer Aided Design.</i>	Node 2. Influence of industry. Node 5. Computer Aided Design. Node 3. Using computers. Node 6. Classroom practice.
<i>Theme 5, different ways of working learned during the project.</i>	Node 2. Influence of industry. Node 4. Working with other people. Node 3. Using computers. Node 6. Classroom practice.

**Fig. 11, source: author.**

This approach to mapping the nodes to interview questions allowed multiple consideration of the themes, for example node 5, Computer Aided Design, is allowed consideration against questions that deal with themes 1, 2, 3 and 4. This was because, at this stage in the research, I found that I needed to allow for the possibility of transformation arising from different and multiple sources of influence within the case study. I felt these influences could have been due to any or all of the following precedents:

- The influence of computerisation on teachers' pedagogy, where pupils' designing and making was probably being influenced by the introduction of new software and machine tools during the case study.

## Transformation and Pedagogy

- The influence of Electronic Product Definition on teachers' pedagogy, where pupils designing and making was probably less derived from their own personal needs and design intentions.
- The influence on teachers' pedagogy of certain aerospace manufacturing approaches, which may have been new or unfamiliar to them.
- The influence on teachers' pedagogy of the co-location of pupils and other teachers in other schools working on the same product, such as the need to work with people who were not necessarily located in the same physical environment or familiar to them on a daily basis within their own schools.

The themes were also related to the research questions, and had been influenced by the ideas of teachers who would be involved in the Eurocollaborator project at the outset. These became NVivo objects in the project, which could be used to develop understanding of the effects of collaboration through Electronic Product Definition (represented in node1 as a kind of collaboration).

### **5.4.2 The axial coding, linking the categories and concepts within the NVivo model.**

Three principal concepts were developed for the axial coding and connecting of categories. These principal concepts were selected so as to be capable of binding others together:

1. **New precedents**, or how ICT may have led to new or un-preceded kinds of learning experiences for the participants.
2. **New practices, theories and beliefs**, or kinds of new precedents or experiences that may have affected teachers' thinking.
3. **Pedagogy**, or how pedagogy may have been changed because of experiences during the case study.

### **5.4.3 Summary of the linking process and use of Grounded Theory.**



## Transformation and Pedagogy

The idea behind the linking process was to develop and check concepts using principles grounded in the practices observed and articulated by the participants in the case study. The linking was also to help provide more generalisable ideas from the study of aerospace engineers working in schools in a transformational context.

This summary therefore contains many NVivo terms that teachers have used during the case study interviews. Some of these seem highly relevant to the categories, others seem less so. Some seem very clear while others seem to be more fragmented. Sometimes different terms seem to overlap in their meaning or are used by different interviewees to describe different but related issues. For example, the expression ‘rubbing’ was used by both teachers and engineers to describe the influence people have on each other when working in association or in collaboration. In fact the term ‘collaborating’ is far less often used. One teacher in the south of England described the effect of engineers working with him during the case study as “providing a rub-off effect”, allowing his pupils to “see different sides from industry”. An engineer working in a different district and with different schools, explained how different schools involved in his project “were often rubbing up against each other” as they attempted to solve the problems of working in association with each other from different locations. The expression ‘rubbing’ was being used here to describe how individuals and groups came to influence each other through various project-encounters. There are slight differences of emphasis therefore.

‘Rubbing’ could be developed into an NVivo concept if this seemed useful. This would be the case if it contributed to the research question ‘How does ICT facilitate the transformation of pedagogy within the Eurocollaborator Project?’ For example, it could be argued that the teacher meant some of the work-practices learned using Electronic Product Definition had ‘rubbed off’ onto his pupils in school via the case study. By this ‘rubbing-off’ he was comparing the learning of his pupils with the phenomenon of coatings being rubbed onto surfaces by contact with each other. He meant that his pupils came to better understand engineering because they had made first-hand contact with it, rather than just hearing about it in school. He was also portraying the world of school as something separated from the world outside school. He was explaining the usefulness of events or people from these different worlds

making contact with each other first-hand, rather than through books or through learning from assignments conceived and run entirely within the classroom. 'Rubbing-off' might be an even more useful concept if its relevance to teachers' pedagogy was shown, or helped to better describe it. If learning with ICT in the case study led to a rub-off effect on pupils, and if that seemed to enhance their learning, then this particular NVivo concept would be more useful and could be connected to other NVivo categories through associating and linking. To be useful in describing pedagogy, it might mean examining the idea that teachers can develop useful rub-off effects that influence their thinking, such as in the ways they represent subject knowledge. That this may come about because of pedagogical challenges in representing un-preceded, electronically defined design & technology products, is one possible kind of answer to the main research question in this thesis. However, the design & technology situated nature of the case study would need to be borne in mind before a broader generalisability of this concept could have some validity.

### **5.4.4 Some pedagogy concepts that arose within the case study analysis.**

#### 1) 'Rubbing off' effects

This described the phenomenon of learning from using ICT in a context formerly developed beyond school, in this case the context was aerospace engineering. Rubbing off might also result from encountering or using tools within software that were developed for particular industrial purposes, rather than for classroom ones in their own right.

2) 'Product sectioning', 'Product interface freezing', 'Product interface specifying' are different NVivo concepts that each relate to a common phenomenon. In each case the interviewee is attempting to describe or to define more clearly some kind of product, creation or condition.

In 'sectioning' the product the ICT is being used to provide useful data that describes it more clearly. This could mean trying to get her/ his bearings more clearly established so that the product can be better understood or worked upon further. This is still an exploratory or developmental stage and it may be associated with collaboration and further development.

In 'freezing' the interfaces of the product the exploratory/ developmental stage has been concluded. This concept relates to work where different individuals may need to contribute to or use the same product in some way. Interface freezing is a means of preventing further change, rendering the data reliable and constant to different persons.

In 'specifying' the product the ICT is being used to lay down certain limits or parameters, which must be worked within by different individuals. 'Cross-boundary working' is related to this and describes a process of working between one product or component and another owned by different collaborating school teams.

If developed further, these NVivo concepts could be replaced with a single one, such as 'product defining', an idea which might have particular relevance to the teaching of design & technology. However, I felt that each of these terms seemed to have been improvised by people involved in the case study, or newly developed for the classroom to represent the new demands that the project had placed on people, and it seems not unreasonable to suggest that they did evidence changes to teachers' thinking. These changes could be described in terms of an accommodation of new kinds of design & technology subject knowledge alongside, or in place of, more usual and preceded teachers' knowledge. Improvising these new terms came about because usually preceded teachers' knowledge fell short when dealing with a new kind of electronically designed product, one that needed to be realised collaboratively across multiple school sites, rather than by individual pupils in a single classroom.

### 3) 'Template working'.

Template working described conditions in the project where ICT was used to regulate the work being produced, and was largely electronically defined. This idea was not quite the same as product-defining though; rather it described certain conditions within which the pupils had been asked to work. The templates here provided boundaries within which their work-responsibility was contained. Templates allowed decisions to be made without bringing a conflict into the finished work. They tended to be used to ensure some kind of subsequent fitting together of components or parts and the idea seemed also to convey that others (not present) would be following the same template information. Templates provided labour-saving strategies, or methods

that focused attention or organised thought, and reassured those involved that their combined work would eventually come together in one assembly (although the possibility that this might not actually work was also a common anxiety mentioned by interviewees). Templates can also be regarded as tools.

### 4) 'Ideas joining'.

This described the use of ICT to model and to develop thoughts from an early developmental stage to a more developed one.

### 5) 'Error making'.

This describes a way in which ICT can aid learning by allowing mistakes to be made and facilitating corrections and improvements. It could be thought of as a means of refining learning. Good learning was described as 'an excellent error' by an interviewee.

### 6) 'Sticking to the drawing, boxing in, book-work'

These terms were used by teachers when describing ways the project collaboration developed, or was represented in their teaching. In an interview with engineer CF at Filton Aerodrome (coding report 7/08/01, node 1, passage 5, section 1, paras 15-19), 'sticking to the drawing' referred to confining pupils to the limits of the electronic definition of the consortia's product, while 'boxing in' referred to the pupils' particular share of this work. These approaches were felt to be in contrast to the more usual ones, described by engineer MF at Filton Aerodrome (coding report 17/08/01, node 2, passage 16, section 4, para 127), as the 'book work learning' approaches that had been adopted in teachers' prior subject teaching.

This collaboration was in contrast with more familiar kinds that teachers had already experienced up to that point in their design & technology teaching. The new kind of collaboration introduced by the project was not perceived as straightforward, however. Nor was it the same as pupils just working together (rather than working on their own). The interviewee seemed to be saying that the project collaboration involved varied kinds of discipline, as well as the more obvious sense in which collaborators consider and communicate with each other. This involved sometimes not having any obvious dialogue or discussion as such, but agreeing to abide by the

electronic definition of the plane, together with the contractual obligation to build each component with conforming adjoining interfaces. There are times when the appropriate approach *is* sticking to the drawing or when there is not much need to collaborate. Engineers refer to ‘working away from collaboration’ after the product has been frozen.

### **5.5 SUMMARY OF FINDINGS**

The six pedagogy concepts are manifestation of the case study, one situated in design & technology and aerospace manufacturing. They provide grounds for suggesting that that new precedents influenced development of pedagogical practices, theories and beliefs. If this was in fact the case, it can also be argued that this represented aspects of transformation that were relevant to the research questions.

The NVivo analysis also allowed transformation phenomena to be compared for teachers and engineers. This comparison and other NVivo data is presented in fig. 12 overleaf to help clarify what was being interpreted as transformation, representing quotes taken directly from the interviews.

Fig. 12: comparing transformation data through NVivo

<b><u>Comparing possible transformation data through NVivo analysis</u></b>	
<b>Teacher comments</b>	<b>Engineers comments</b>
<p>‘Pupils really latched on’</p> <p>‘The lending of interesting problems’</p> <p>‘Increasing of comfort levels’</p> <p>‘As an alternative to bolt-on work’</p> <p>‘Working with engineers on the project provided a rub-off effect’</p> <p>‘We were rubbing shoulders with engineers’</p> <p>‘The pupils were able to see different sides from industry’</p> <p>‘Quite different from just working in limbo and just working in school’</p>	<p>‘Partnering with industry’</p> <p>‘Reconciling a difference of operating philosophies’</p> <p>‘Eurocollaborator was pretty much stand alone’</p> <p>‘I think it was the methods, not the content that made the work different.’</p> <p>‘The different schools were often rubbing up against each other’</p> <p>‘We were often rubbing up against each other on different areas of the work’</p> <p>‘The teachers could be similarly driven’</p> <p>‘We needed to lift our game’</p>
<b><u>Describing some of the practices that were developed</u></b>	
<p>‘Early stages of new work when anything went’</p> <p>‘In the early stages, starting up the wrong alley’</p> <p>‘We were out for several months at the beginning’</p> <p>‘We being the only ones in step’</p> <p>‘After a while, coming on line a bit’</p> <p>‘There was hair-tearing out and panic when things did not go well’</p> <p>‘An alternative to being stuck in the same environment all the time’</p> <p>‘Using the software right across the board’</p>	<p>‘Making an excellent error’</p> <p>‘Avoiding stand-off industrial relationships’</p> <p>‘To kick someone’s arse and get them into gear’</p> <p>‘This was not a book-work learning’</p> <p>‘Pupils overtaking the teachers’ knowledge to become wizards’</p> <p>‘Fitting the project in or around the school syllabus’</p> <p>‘This was a big step-change in the way the schools worked’</p> <p>‘Grinding your way through the software’</p>

<u>Describing some of the participants reasoning behind introducing innovative work</u>	
<p>‘Not wanting to box them into a particular route’</p> <p>‘The pay off came later’</p>	<p>‘To be able to find win-win solutions’</p>
<u>Describing some of the collaborating in practice</u>	
<p>‘Sectioning off our part of the product with ICT’</p> <p>‘All hooked up together’</p> <p>‘With more heads involved’</p> <p>‘The pupils ran with it’</p> <p>‘At the end it was basically a last minute jammit together’</p> <p>‘We would pull together and talk about it’</p>	<p>‘A critical point is when the interfaces are frozen and there is no longer any need for collaboration’</p> <p>‘There are often times in industry when we are not collaborating, just working on our own without being disturbed’</p> <p>‘In the early stages they were just waiting to be spoon-fed’</p> <p>‘To get together and talk across the interface’</p> <p>‘To work with each other across the boundary or just outside their own school’</p> <p>‘Using interface specifications and sizes to communicate with others they are interfacing with’</p> <p>‘If communication is not crystal clear there will be problems’</p> <p>‘Different interpretations of what was required were bandied around’</p> <p>‘The other members of the team were not always visible’</p>

	<p>‘Working to exactly the same design, to the exact same templates’</p> <p>‘Helping the ideas to join up’</p> <p>‘The pupils were able to take that on board’</p> <p>‘The pupils began to work well when someone’s name was in front of it’</p> <p>‘Without being clear about where they are going in industry, they will just stick to the drawing and work to the last minute’</p> <p>‘If you have all of the answers there is little point in talking to one another beyond that point.’</p>
--	--

**Fig. 12, source: author**

The prior research and analysis, together with the above examples from the case study, supported the idea that teachers’ pedagogy is complex and suggested that pedagogies may be influenced in many different ways. It suggests that pedagogy is multi-dimensional and can be both short and long term in its character.

The analysis, supported by the comparisons and extracts, was used to help describe transformation and pedagogy more clearly and through an approach that was derived from some of the traditions of Grounded Theory.

The analysis of the data also suggested that:

- Transformation can be described both as a condition (one where prior accepted precedents are questioned or challenged) and as a process (where the un-precedented may have the effect of helping to reshape pedagogy). These are described here as two separate things because the analysis of the case study



## Transformation and Pedagogy

did not suggest that pedagogical transformation followed the introduction of ICT in the case study. Rather it was the challenge presented by particularly situated uses of ICT that provoked pedagogical reflection on the part of the teachers.

- Interaction influenced pedagogy. It was possible to describe different participants in the project, for example as agents (link-engineers), changers (teachers) and benefactors (pupils) acting in roles, although many of these roles overlapped and were seen to be interchangeable. For example, at times the changers were pupils and the benefactors were engineers.

The data in the case study were telling me about ways teachers altered or adapted representations of their subject knowledge. In this case the teachers had been faced with conditions which were likely to introduce new kinds of pedagogical precedence, ones brought about by industrial manufacturing approaches rather than more usual design & technology teaching ones. Both the development of new design & technology practices, epitomised by the idea of electronic rather than personally defined design & technology products, and the relationships between the different participating teachers and their pupils, seemed to stimulate the change processes in teachers' thinking, so providing access to new understandings within the research data.

The evolving flow-logic diagram can now be reshaped using these understandings as shown overleaf:

Fig. 13: the framework for analysing transformation, post-NVivo, third iteration.

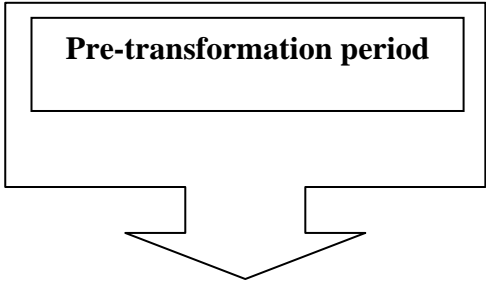
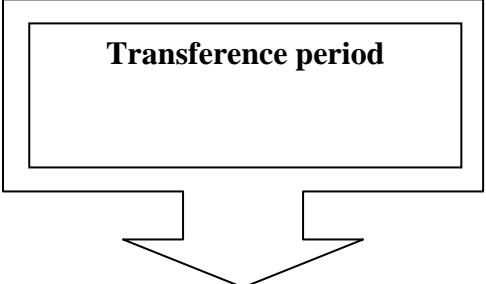
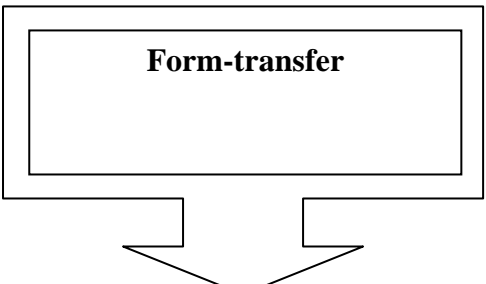
 <p><b>Pre-transformation period</b></p>	<p><b><i>The teachers and engineers recognise that they work in different worlds.</i></b></p> <p>Pre-transformational methods in design &amp; technology were questioned. Ideas for passenger aircraft designs have to be developed with others. More usually preceded design &amp; technology methods continued to be used in the early stages of the project, but changed when confronted with new precedents presented by the electronic product definition of the planes.</p>
 <p><b>Transference period</b></p>	<p><b>The motivation to participate is connected with a desire to improve the learning of the pupils through a deeper understanding of industrial practices.</b></p> <p>New approaches initially, developed via more usually preceded ones, such as sketching with pencil and paper, led to new thinking involving the role of Computer Aided Design in collaborative manufacturing. Collaboration in building the defined product (a plane) led to reliance on new approaches where the product and work became electronically defined.</p>
 <p><b>Form-transfer</b></p>	<p><b>Improving the learning of the benefactors in the project is bound up within the need to achieve a successful product-solution (concept airplane, collaboratively designed, manufactured and successfully assembled).</b></p> <p>Final planes were refined using electronic product definition. Work-sharing required an electronic product definition, information could only be provided in this way, so had to be</p>

	<p>trusted and relied upon. Work progress therefore required an electronic product definition, one which represented new precedents and the pedagogically un-preceded.</p>
<div style="border: 1px solid black; padding: 10px; text-align: center;"> <p><b>New pedagogical practices, theories, and beliefs arising from transformation-precedents</b></p>  </div>	<p><b>During the Eurocollaborator project the participants encountered new experiences, which may be described as transformational in their nature. These were also bound up with the role of ICT as the participants perceived it, specifically the extent to which ICT may change everything rather than being just something to be learned.</b></p> <p>Evidence that new practices, theories and beliefs may be initiated by the pedagogically un-preceded.</p>
<p><b>Pedagogy issues</b></p>	<p><b>Transformation and pedagogy change were associated with new precedents and practices that had to be developed in order to complete the work in Eurocollaborator.</b></p> <p>Pedagogy was challenged by the project. Teachers reviewed and modified their methods of presenting the design of challenges and assignments to pupils in design &amp; technology. This approach was experienced within a prevailing climate of embedding in the schools, yet was largely characterised by a prevailing climate of discovery during the case study due to the innovative character and design of the project.</p> <p>Expectations of pupils by teachers, as well as success criteria, were altered during a process which was influenced by transformation conditions.</p>

Fig. 13, source: author.

### **5.5.1 Summary of concepts that have emerged.**

I narrowed down to three NVivo concepts to connect various categories developed during the analysis, each representing a kind of learning that implied the possibility of new pedagogy precedence. These concepts were then used to inform my main research questions:

1. Rubbing off learning.
2. Template learning.
3. Interface learning.

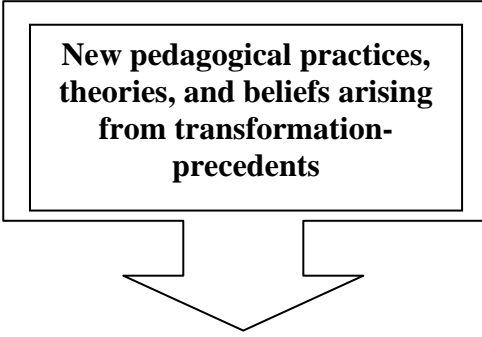
As connecting categories these helped in grounding:

- What interviewees said during the case study and of their uses of ICT.
- What the teachers and engineers said of their own ways of working and of their pedagogies.
- My earlier pre-conceptualisations developed during the literature review.

### **5.5.2 Other forms of data that can be linked to the NVivo interview data.**

Some other forms of data can also be linked within the NVivo project, including:

- The flight simulation video showing the six electronically defined concept planes, presented at the conclusion of project gathering and celebration at RAF Cottismore in July 2000.
- The finished aircraft models.
- Video of final assembly of a Southern Consortium aircraft, 'C5'.
- Various photographs and slides taken during the case study.
- The influence on teachers' thinking of new materials processing methods provided by Warwick University Rapid Prototyping Department.
- Computer files used as electronic product definition and in sizing the planes.

### **5.5.3 Extensions to the ideas developed within NVivo.**

Some of the previous ideas have been further extended, involving some shifts in emphasis. This was part of an on-going process of interpreting the data and its complexities. These are also referred to in chapter 6, which deals with the significance of the study.

If the broad historical themes I developed during chapter 3, The Literature Review, are accepted, then it can be argued that the case study was taking place during a period I have described as pervaded by an embedding (rather than discovery) pedagogy tension. Some evidence supporting this idea was found in interviews and through recorded conversations that described the work teachers and pupils were doing. These dealt with learning situations, which were largely not embedding but instead discovery oriented, due to the transformational nature of the project.

The analysis of the case study was used to examine transformation and pedagogy phenomena, including new terms that teachers used to describe certain kinds of learning that they thought took place because of the nature of the project such as 'Rubbing-off learning', 'Template learning', and 'Interface learning'.

These ideas were examined and it was argued that they involved new pedagogical representations, ones situated in design & technology teaching and the aerospace manufacturing context of the case study. It has also been possible to compare the ideas with other thinking, for example there may be similarities between pedagogy for 'rubbing off learning' and Bruner's 'folk pedagogy' (Bruner 1996, 44-65), where he describes ways teachers informally evolve pedagogy in the manner of a folklore of school practice.

Pedagogies implied by interface learning might run closer to the ideas put forward in this research on transformation, especially where teachers' thinking seemed to be influenced or challenged by precedence. The example of the pupils from one school who decided to change the design of their undercarriage without due observance of the strictly defined specification, the 'frozen interfaces' which regulated the consortium of schools building the plane, was perhaps a more tangible example of

## Transformation and Pedagogy

where the un-preceded challenged more usual preceded practices. This usual preceded approach compromised the success of the whole plane and put peer pressure on the engineering team managing the project, while a teacher's description of this as the student's 'lapse into freedom' to change things the way they wanted was a reversal of the more usual preceded approach in design & technology, one where pupils are usually encouraged to take control and make personal design decisions as a matter of routine.

In describing how this interface learning observed in the case study bore on transformation it has been possible to describe certain phenomena that are central to the research question on transformation and pedagogy. It has been shown that both embedding and discovery pedagogy tensions may exist at the same time or alongside each other, for example they both had bearing on the success, or otherwise, of participants in the case study and the work and learning they undertook. The idea of 'template learning' illustrates this point, being based on a kind of exact conformity that may seem to accord more with an embedding than a discovery approach to using computers.

Within this interface learning the case study participants entered into an experience where new kinds of working relationships became implied, or were in fact project-givens. These needed to be developed in order for success in collaborative product design and production to be possible. They included different ways which the teachers and pupils, from different schools that were working on the same electronically defined product, had to work with each other and the BAE SYSTEMS engineers. These relationships; which included 'access to', 'involvement with' and 'responsibility for' interfaces of the design; are similar to certain theoretical ideas on cognition and learning which are being used to more clearly understand ways ICT can enhance learning and pedagogy. For example, socio-cultural thinking has mentioned creative tensions inherent in embedding ICT in subject-based learning (Sutherland et al. 2004, 412), and seems relevant to ways teams of teachers and engineers observed in the case study developed the various uses of information and communications technology into engineering and classroom practices. The driving force behind such learning could also be described in socio-cultural terms, such as ways in which teachers and engineers formed communities of learners based on taking account of

## Transformation and Pedagogy

each other's perceptions of the classroom and what constituted improved learning. In my case study this was being evidenced through the collaborative nature of aircraft design and manufacture. This was shared between different schools, and required clear understanding of adjacent and shared interface responsibilities. In working closely with each other, while located in different schools, communities of learners shared novel engineering approaches encouraged by the project, and also a kind of collaborative endeavour that was new to them. The case study offers ways to think about pedagogy from alternative perspectives, where observations of pedagogy change provided a rationale for certain new concepts of precedence.

The claim for transformational precedents arising during the project was based upon the designed-in need for the teachers and pupils to understand certain engineering interfaces if a successful product (in an engineering and aviation sense) was to be achieved. Having gained this understanding they had to act upon it, both locally in their home schools and across school sites. This activity involved interactions that were both iterative and binding in their impact on peoples' actions and on teachers' pedagogies.

The precedents in the project relied upon certain approaches with computers and ICT to be both established in the thinking of participants in the first place and then maintained for the 2-year duration of the project. These can be differentiated as 'object interfaces', or physical objects or surfaces whose shape defined certain boundaries that affected the successful co-construction of the plane, and 'process interfaces' which described certain aspects of the collaboration and work-share, such as communication and dialogue between partners in other schools, shared deadlines for completing or constructing certain things that different teams needed to interconnect as well as change and alteration to original design intentions of the teams. These precedents came to represent certain pedagogically un-preceded situations for the teachers, ones exhibiting a relationship between pedagogy and transformation in the context of the case study. The result is a portrait of a transformation, situated within a design & technology subject-teaching context, and ways its associated pedagogies underwent adjustment.

## Transformation and Pedagogy

The underlying themes used during this research were helpful in articulating pedagogy phenomena in greater detail so that it could be more closely examined. The new software and approaches needed for Electronic Product Definition allowed teachers to conceptualise a transformed design & technology knowledge, but in practice it was the precedence arising from iterative and binding interactions in the project that impacted on peoples' actions, so changing teachers' practices, theories and beliefs through challenges that had to be accommodated in pedagogy terms.

Causing teachers to reflect upon their existing pedagogy, and that of a potentially changed one, was a case study design strategy and did at least seem to result in pedagogy learning. Contact with 'interface learning' gave teachers an opportunity to transform their prior design & technology subject knowledge, albeit through a process that was carefully supported by Eurocollaborator project management and developed on a cautious basis. The case study provided opportunities that allowed teachers to develop pedagogy transformation, ones where a confronting of prior pedagogy assumptions was possible and allowed change. I felt that this was a situation where a new design & technology (interface) pedagogy became needed, one where teachers did develop a knowing of computers pedagogically, a knowledge contextualised in ways industrial manufacturing became integral to successful case study activity.

In chapter 6 the significance of these findings will be finally examined.

## **6. THE SIGNIFICANCE OF THE STUDY**

### **6.1 REVISITING THE CONTEXT AND OVERVIEW OF THE THESIS**

I began this research by saying that the case study, Eurocollaborator project, was transformational because it positioned teachers, pupils and engineers in certain new contexts where they encountered new precedents that called their existing pedagogies into question. Dealing with these new precedents became fundamental to the way that they had to work within the case study. This meant working collaboratively and through an electronically (rather than personally) defined design & technology product. The justification for this being a transformational context, in design &



technology pedagogy terms, was also developed through examining the history of design & technology teaching in chapter 2 and ideas on how pedagogy in relation to designing and making more customary design & technology products (than those required in the case study) had evolved. Electronic Product Definition in the project helped to situate uses of ICT in design & technology teaching and learning within an industrial manufacturing context. The evidence for this being transformational was also examined from the review of other kinds of literature to that of the history of design & technology teaching, including of manufacturing industry (chapter 2), a historical perspective on ICT pedagogy and transformation (chapter 3) and current views of pedagogy and transformation, including theories of learning.

From my research I believe I have developed insights into the world of teachers, while the case study data has presented pedagogy in a highly original and significant way that is relevant to the current period in education. This involved examining deeply ways teachers' practices, theories and beliefs became reshaped in response to pedagogical precedence in uses of ICT. However this could not be shown to mean that all teachers always develop pedagogy transformation in response to pedagogy precedents. Generalisability, reliability and validity also remind the researcher that the case study was design & technology situated.

This new thinking does lead to certain other questions, such as whether or not the Eurocollaborator case study was truly transformational according to my emerging conception of what it means to be transformational, together with the key question of generalisability. Here it is necessary to discuss whether or not the pedagogy precedence described in this study was a special case, together with any lessons there were for the development of pedagogy. The Eurocollaborator project and the findings might also have potential to be influential on design & technology teaching.

These ideas on transformation, pedagogy and generalisability are examined in this chapter, alongside the research questions as stated at the outset.

## **6.2 THE RESEARCH QUESTIONS**

In chapter 1 of this thesis I stated my research questions as follows:

Fig. 1 : the research questions.

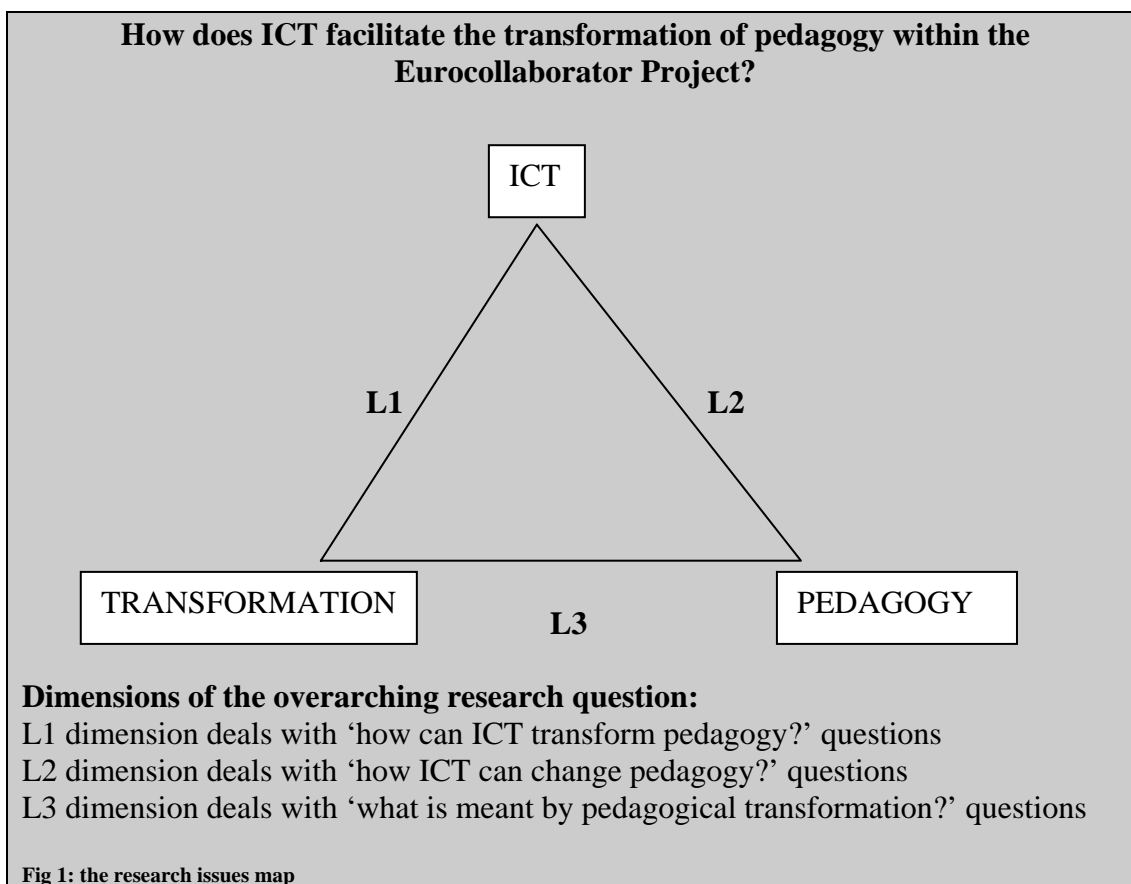

**Fig. 1, source: author**

Questions then developed for the purposes of the research were as follows:

**L1 questions:**

1. What is meant by transformation in the context of this case study?
2. What processes of transformation, if any, arose from new Information and Communication Technology approaches learned from the aerospace industry?
3. How did this influence the pedagogy of teachers involved in the case study?

**L2 questions:**

## Transformation and Pedagogy

1. Were there ways, besides transformational ones, that ICT helped to change or alter learning and pedagogy (bearing in mind that these were not a main consideration in this research)?
2. As my overriding research question **01** deals with the idea that ICT can facilitate the transformation of pedagogy, as different from just changing it, can this kind of question be useful in helping to distinguish processes that ARE change but ARE NOT transformation?

### **L3 questions:**

1. How did working and collaborating with other schools during the project affect the learning and pedagogy of those who took part?
2. What evidence was there that designing and manufacturing with an electronically defined product (as different to more conventional design & technology approaches) had any particular influence on learning and pedagogy?
3. What else could be said about ways that the project was used in the classroom?

## **6.3 THE RESEARCH AND THE LITERATURE DRAWN TOGETHER**

The main ideas developed in this thesis, on pedagogical theories and principles in the context of the transformation defined within the case study, are examined next. The strategy used here will be to examine ideas using a further evolution of the flow-logic diagram, as initially developed in chapter 3 (Yin 1993), to help group them alongside the research questions.

Some of the sense from the most recent iteration of this diagram, fig. 13 from chapter 5, will be built upon during this later one fig. 14. However, a cautionary note is required at this point. Firstly, the earlier flow-logic diagram had for visual convenience described transformation and pedagogy as a vertical linear process, which may well not be the case in reality. Secondly, certain changes may be needed both to the original form of this diagrammatic representation and its descriptions. It is therefore important to clarify that the flow-logic diagram is used here only as a means to represent certain phases of transformation and pedagogy, as consistent with the

## Transformation and Pedagogy

advice on using Grounded Theory (Yin 1993). It will be the identification of these phases, rather than any linearity that may or may not exist between them, that form a focus for drawing the research and the literature together. Nor, by this, is any deterministic description of pedagogical transformation being suggested. Nor is it intended that the phases identified next are watertight categories as such, rather their use represents ways of thinking and ideas that help to provide a perspective on transformation and pedagogy.

My flow-logic approach is therefore used to help build a framework for both further consolidation of ideas and a means navigate through ideas based on the adoption of approaches, drawn from some of the traditions of Grounded Theory, used in the research. The descriptions and pedagogy issues have been removed from the earlier flow-logic diagram for this concluding treatment and are developed instead under four phases of transformation now identified in fig. 14, overleaf. Each will be used to develop a perspective for conclusions on whether or not the Eurocollaborator was truly transformational in terms of my emerging conception of what this means, the key question of generalisability, lessons for the development of pedagogy, the research questions and the literature that has been reviewed. Suggestions are also made for how the case study and the findings might be applicable to development of design & technology as a subject.

Fig. 14 : The framework for analysing transformation, fourth iteration of flow-logic diagram.

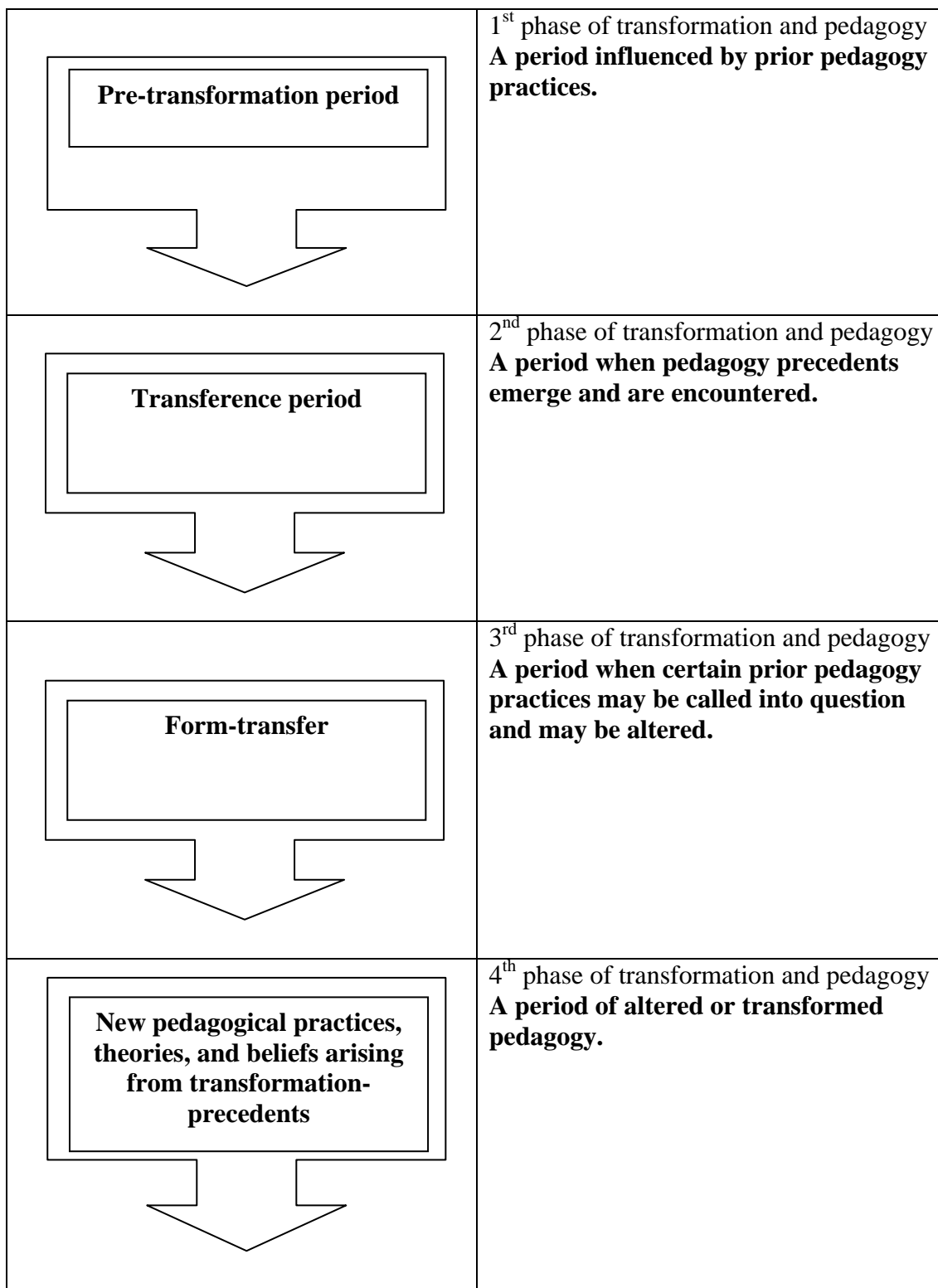

Fig. 14, source: author.

### **6.3.1 First phase of transformation and pedagogy: a period influenced by prior pedagogy practices and the concept of pre-transformation.**

How was the case study transformational and what did this mean in the early stages of the project?

A position adopted here is that at the outset of the project any transformations, intended or otherwise, would have yet to take place. As already mentioned, the design of the research initially focussed upon the work that would be done by the consortia of schools rather than on pedagogy as such. The work in these different manufacturing locations would be managed so that inconsistencies were minimised. As in manufacturing industry, workers (teachers, engineers and pupils) would not need intimate knowledge of the whole product, instead it was hoped that the electronic definition of each plane would provide a reliable framework for them to operate within. It has been shown that, in manufacturing industry, the phenomenon of EPD led to new practices for those involved in the manufacturing design and production (Broughton et al. 1995). Alongside these new manufacturing practices there existed a manufacturing precedent in the prospect of zero ambiguity, production methods being re-written because of it.

The above process was being introduced through the project to explore alterations to the form which typical design & technology learning took. Certain things helped with this. There were already certain manufacturing similarities between the ways design & technology was typically learned and taught and this customised factory production approach (Ritz et al. 1990), for example materials were being fashioned and shaped by the pupils and a product was being made. The transformation of design & technology here was that EPD removed the prior total responsibility by the student for the product. As the project developed, the idea was to look at things that may have replaced this total responsibility as well as how the teachers and pupils reacted to this during the case study. It was hoped that the manner of this replacement might represent the new precedents, practices, theories and beliefs associated with a transformation and pedagogy as defined in this research.

### Generalisability

From this early stage in the case study there was an intention to develop ideas that were generalisable within the subject area of design & technology, for example beyond the BAE network of schools into design & technology teaching generally. However, in needing to evolve theory on transformation as a way of describing pedagogy changes arising from the case study, it should be possible to more broadly generalise on what a transformation is. Care is also needed in assuming linearity between the phases of transformation outlined here or in assuming that a pedagogy transformation automatically follows a transformation affecting a subject.

### Lessons for the development of pedagogy: how the case study and the findings might be applicable to development of design & technology as a subject

During this initial phase of transformation, teachers' interests were shown to be more on subject concerns than pedagogy. The case study did not portray pedagogical transformation as an immediate or revolutionary phenomenon arising from ICT. Instead, the transformation began with the precedent of newly introduced industrial manufacturing subject knowledge arising from the project. It became possible for participants to use this knowledge through the medium of ICT. Pedagogical transformation seemed to evolve subsequently into a number of pedagogical arguments or expressions during the two years of the case study, or when there had been time for some kind of reflective process where such deeper issues were considered. In the initial stages of the case study the teachers did articulate that something was wrong with their uses of CAD/CAM and for many, addressing this problem by joining the project and with the help of BAE SYSTEMS was a prime concern. There is evidence that it was not until they later encountered precedents arriving with EPD approaches in their subject that they considered pedagogy as well. However, it was the uses of EPD (rather than computers per se) that represented the precedents and helped call into question prior pedagogy. These uses are key to the idea of understanding this particular precedent and are developed a little further: it was perhaps not fully realised at this initial phase how the uses of EPD to define what was required of pupil groups and their teachers in each school would impact upon them. The main differences between EPD and more usual preceded design & technology approaches have already been described in detail in chapters 1 and 2 (Ritz

et al. 1990, Broughton et al. 1995), however it can be restated here that in defining the product and its component electronically, pupils' personal ownership of certain central design & technology decisions, at that stage customarily personal designing and making ones, were altered and became collaborative ones. It may be said that it was in becoming accustomed to this new idea, together with its implications for the applicability of a hitherto unquestioned design & technology process, teachers and pupils faced a new precedent. It was this facing of the precedent, an un-preceded pedagogical situation, and becoming more familiar and accustomed to its import for the prior approaches (including pedagogy ones by this stage) that teachers were able to call earlier modes and practices into question. During the project this calling into question, or truing of ideas, was also prompted and reinforced by others involved in the project, for example where teachers and pupils from other schools were quick to pounce on and criticize each other's collaborative contributions when these fell short of what was being demanded by the EPD managed approach in case study.

At this point, the main drivers for teachers facing new precedents were:

- Early interest, not necessarily in pedagogy, such as in subject development and hands-on knowledge.
- Network participation, which made the project 'known' beyond the individual classroom in each school. This network participation manifested itself in the form of meetings and dialogue, as well as inter-school activity during the project.

### **6.3.2 Second phase of transformation and pedagogy: a period when pedagogy precedents emerge and are encountered, and the concept of transference.**

How was the case study transformational during this second early phase?

The development of the kinds of new precedents already referred to relied upon ICT to be both introduced in the thinking of participants in the first place and then maintained for the two-year duration of the project. During the early stages of the research I tried to develop new terms for the then more obvious manifestations of the



## Transformation and Pedagogy

precedents as they were encountered, such as the expression ‘object interfaces’, e.g. physical objects or surfaces whose shape defined certain boundaries that affected the successful construction of the plane, and ‘process interfaces’ which described certain aspects of the collaboration and work-share such as communication and dialogue between partners in other schools, shared deadlines for completing or constructing certain things that different teams needed to interconnect as well as change and alteration to original design intentions of the teams. This helped me to differentiate the project’s influence in terms of different kinds of possible transformation, such as the distinction between the teacher’s design & technology subject competences, the work they did and their pedagogies. I also began to appreciate the influence that certain new precedents, already mentioned, were having on the teachers through my interviews and discussions with them in each school.

### What does transformational mean here?

The transformations intended were at this point still focused more upon certain challenges presented in building the planes than on pedagogy. However, early evidence from the interviews suggested strongly that the teachers and pupils involved in each plane-building consortium were being confronted with certain new precedents and practices during the design and manufacture of each plane. This arose from their sharing of the single electronic definition of each plane, and working together in a distributed manner. The pupils seemed to experience certain new kinds of subject learning in design and technology. Interviews were also suggesting that the teachers began to experience the project in ways which also stimulated pedagogy learning, the design of the interview questions having been developed to reveal such a possibility.

### Generalisability

I am addressing the issue of generalisability from three standpoints: the interpretation of meanings into concepts and theory; the credibility of my concepts and theory beyond the case study situation; and, the processes of data collection and ways I attributed meaning to those data.

## Transformation and Pedagogy

Particular meanings, in relation to my research questions on transformation and pedagogy, have been interpreted and developed in this thesis. The case for these concepts and theory has been built in some detail, bearing upon the historically consistent difficulty teachers have had in re-thinking learning or pedagogy since the early introduction of microcomputers to schools. This has been shown as a significant problem, one broadly recognised in varied and international research writings and literature on this subject that has been examined at length in this thesis. My interpretation of meanings into concepts and theory has been influenced by the argument that new work was needed on describing and addressing this pedagogical phenomenon. For this reason I have developed alternative thinking on transformation and pedagogy in relation to ICT.

My strategy for developing these concepts and theory was also conditioned by the international scale of the problem, together with the research opportunity that this project presented. If we reject the idea that the computer has been simply (or perhaps cynically) recruited by teachers to preserve older and possibly outmoded pedagogical practices, then it will be useful look for alternative explanations of the difficulty. After all, the reasonableness of prior rhetoric in favour of pedagogical re-thinking over the last thirty years or so seems to have failed in leading teachers to the new pedagogical reasoning they need. The generalisability of my research into this significant and problematic phenomenon is in providing alternative ways to articulate transformation and pedagogy, or to successfully describe preconditions for teachers undertaking pedagogical transformation in relation to ICT. Since beginning this research, this undertaking has subsequently been argued to concern the national well-being (Becta 2006).

Justification for generalisability in my research therefore begins by establishing the idea that new theory and concepts seem to be needed to more fully understand the pedagogical difficulty that I have described. However, the generalisability that I am able to offer is only – and can only ever be – at a theoretical or hypothetical level and its idea would need to be redeveloped and re-tested in every case.

A second issue for achieving generalisability is the extent to which it was reasonable to draw these particular research conclusions on transformation and pedagogy,

## Transformation and Pedagogy

qualified by the credibility of these concepts and theory beyond the immediate case study situation. Describing new pedagogical reasoning as a transformation did seem to provide ways of describing the research phenomenon in more generalisable terms. These could be applicable beyond the situation of my case study. This was suggesting that any pedagogical re-thinking might involve the teachers actually coming to know the computer and ICT pedagogically, and that this knowing of something pedagogically was special or different to other kinds of knowing. This was an attempt to develop useful and generalisable ideas, ones substantiated through the interpretation and analysis of research data. In the same way as before, this generalisability is only at a hypothetical or theoretical level and would benefit from redevelopment and testing in other cases.

A third condition of this generalisability concerns the processes of data collection, analysis, and decisions I took about what the data meant in relation to my research questions during the extended period of analysis. In this case, data were collected in relation to what teachers themselves were saying about their pedagogies during a carefully designed, two-year case study. This design tested the general plausibility of ideas in relation to transformation and pedagogy. Theoretical substance had been suggested for both ideas, as had the plausibility of re-thinking the more situated design & technology subject knowledge in relation to ICT. Particular meanings were developed and substantiated through listening to what the participants in the case study had to say and, while these were situated in design & technology teaching, the focus here on a missing pedagogical representation made it possible to examine changes to pedagogical reasoning more deeply than would otherwise have been possible.

It seems more possible to broadly generalise on what a transformation is, than that this particular case study as such would have similar impact on other teachers' pedagogies, such as those with different subject backgrounds to the design & technology teachers involved. However, there are certain other findings from the project, which could offer potential for generalisability beyond design & technology teaching. For example, teachers in the case study revealed certain allegiances and professional beliefs in terms of what was good or bad for education, learning and teaching. The precedents of the case study, ones already described at length, did not

## Transformation and Pedagogy

always seem to be comfortable ones or especially welcome at times. The responsibility of meeting project deadlines, in the face of censure from other teachers and pupils in the other schools, perhaps undermined prior approaches that had always been acceptable before, and at times seemed to abruptly replace these or required a great change-effort on the individual teacher's part. It would be hardly surprising if such change were not regarded favourably or did not win support in the first instance. The transformation to pedagogy described by those involved in the case study seemed to need a strength to overcome allegiance to prior practice, or where prior ways of doing things took time to learn and were believed to work perfectly well. This strength of conviction needed to overcome the older design & technology allegiances, was helped by the project rationale though, and built up by the participant teachers and engineers over the two years of the project.

These phenomena; of subject allegiances, strength of conviction to overcome prior and more comfortable practices, coping with abrupt change, or being more accountable to others; may have a generalisability beyond this research, for example as potential obstacles to be overcome in helping teachers evolve their pedagogies.

### Lessons for the development of pedagogy: how the Eurocollaborator project and the findings might be applicable to development of design & technology as a subject

The project participants had begun by seeking new subject development and hands-on knowledge, but as the project developed they also began to reflect on pedagogy issues. The interview data suggested this arose from:

- Engagement with pupils and others in classroom activity, work being defined externally but owned and managed internally as well. Progress was to be measured with reference to certain project-defined stages and dates.
- Taking responsibility for completing work in certain ways required for the project to be completed successfully.

As has already been explored at length, these represented new design & technology precedents and practices, ones that came to be implied by the meaning of

transformation in the case study. As precedents, they also represented certain difficulties that had to be overcome for immediate adoption. In this case, the school-based teams had to learn such new territory as how their component would interface with those of other schools, the influence on their work of others who took special responsibility such as for the most adjacent parts, as well as how to maintain and communicate their own progress within a consortium, rather than personal work targets alone.

While allowing for the fact that generalisability of such specific difficulty may be questioned, it is also argued that without the new precedents and practices described here this would not have been a transformation involving ICT, instead it would have been of a more usually preceded kind of approach.

### **6.3.3 Third phase of transformation and pedagogy: a period when certain prior pedagogy practices may be called into question, may be altered, and the concept of form-transfer.**

#### How was the case study transformational during this later phase?

The underlying themes developed to describe possible transformation during this research were also helpful in articulating pedagogy phenomena in greater detail so that it could be more closely examined. However, it was recognised that transformation of objects and work mentioned in the case study were not the same as transformations of pedagogy, nor could it be assumed that these would follow each other.

However it is possible that the new software and approaches required by Electronic Product Definition allowed teachers to begin to conceptualise a transformed design & technology knowledge. But during the analysis of the case study data, it seemed to be that the precedents developed through certain iterative and binding interactions in the project did influence peoples' actions and their rationale for these. In this way I began to suggest that it was the project's precedents that seemed to play the greatest part in changing teachers' practices, theories and beliefs through challenges that had to be accommodated in pedagogy terms. As has already mentioned in chapter 2, some of

## Transformation and Pedagogy

the new ICT required by the project, such as CAD/CAM, had already existed in BAE SYSTEMS network schools prior to the project's inception in 1998, but this had not led to any significant changes in the design & technology approaches of teachers. This was a phenomenon that I had become interested in from a research perspective. The same phenomenon had become apparent to BAE SYSTEMS, although their perspective had also to do with enlightening a future possible workforce.

The transformation described here was not straight forward though, the principle of new precedents at the heart of my arguments about transformation could be questioned. For example, it was neither unprecedented nor un-precedented in the project for teachers and pupils to use a specification in design & technology. But the nature of this new kind of EPD specification was un-precedented in pedagogy terms for the case study teachers, for example in being defined remotely, in needing unambiguous interpretation across school sites, as well as for meeting consortium imposed deadlines (as opposed to those decided by the individual pupil or her / his teacher). These new features of a specification did represent a new precedent in design & technology (one arising from the process of EPD and industrial approaches to manufacturing planes, so was not unprecedented in the world beyond school). The two kinds of specification, one defined by the individual and the other defined electronically by the consortium of schools and engineers, are different yet interdependent in the situation of transformation. It was also no longer necessary to have the deep insights into plane design that would have been more usually preceded in their design & technology approaches, at the project outset.

### What does transformational mean?

Over the two-year period of the case study, the interviews were gradually suggesting that teachers increasingly did reflect on their pedagogies and their design & technology subject knowledge. If this was a consequence of encounters with certain new precedents presented by the project, then it can be argued that the case study began to suggest a transformation in terms of the evolving definition of this idea in my research. The new precedents that the project heralded were in terms of certain uses of ICT (CAD/CAM) combined with an Electronic Product Definition (EPD), and on the face of things, these represented a transformation of subject learning that

## Transformation and Pedagogy

implied changed pedagogy, situated in design & technology. But the particular ways required to design and manufacture the planes, for example from a centrally shared and controlled definition of a final design and assembly, contrasted with the customary and accepted practice that pupils develop design ideas on more personal and individual basis. It was especially this precedent that seemed most formative of new thinking on pedagogy expressed by interviewees.

### Generalisability

Generalisability in this more developed phase of transformation will need justification beyond design & technology subject teaching. It could be argued that the pedagogy learning in this case study was also rooted in teachers' earlier training, as subject specialists, or in the need to maintain certain regimes of classroom management in school (Webb & Cox 2004). The Eurocollaborator pedagogy learning could also be explained through alternative or different theories, which placed low, or no emphasis on the precedents that I have elaborated. For example, teachers' behaviour in response to such precedents might instead have been due to purely socio-cultural factors, or have resulted from the formation of communities of practice (Triggs & John 2004), such as the influence of participation in the community of learners represented by the BAE network as a whole. However, this may not explain the absence of new thinking by teachers who already had access to new forms of ICT in their networked schools but were using broadly unchanged methods and approaches for its deployment in learning. However, the case study did seem to suggest that such pedagogy learning can be supported in particular ways, for example through planned projects and collaboration between professionals related to the subject area.

Lessons for the development of pedagogy: how the Eurocollaborator project and the findings might be applicable to development of design & technology as a subject.

Key drivers became:

- Concern over the risk of failure and its consequences for others (in the other schools) and possible criticism that would follow this.

## Transformation and Pedagogy

- Reflection on and acceptance of possible change to pedagogy.

The project acted as a kind of managed framework, one that involved new expertises and new kinds of industrial project management skills, within which teachers and pupils were able to experience the transformations referred to. The costs, as well as the work of developing this framework over the two years of the project, were shared between the BAESYSTEMS and the schools involved, and developed through high levels of collaboration with the aerospace industry partners and between the participating schools involved.

A perspective of difficulty has been introduced here, one that questions the idea that pedagogy can change in the same ways or at the same speed as a technological transformation. An explanation from the case study evidence suggests that while transformation of a technology may be an abrupt process (or able to be developed independently of the end-user in the first instance), the transformation of a prior or existing practice in teaching, in the context of replacing it with a new practice, is likely to involve other issues. For one thing teachers' practices are often hard-learned or built up gradually over time in their working environment and through experience. This includes the ways lessons and subject learning are managed by teachers, such as classroom control and the disclosure of tasks or gradual building up of class awareness and of special moments in learning, as teacher-transformations of knowledge for teaching and learning purposes (Shulman1987). Such pedagogical processes involve teachers deciding ways to represent knowledge to support the learning of their pupils. In the case study the more usually preceded internal transformations of design & technology knowledge by the teachers was disturbed by the un-preceded pedagogical context of now centrally held definition of the planes, for example involving complex changes and adjustments to whole class interaction and ways of reinforcing understanding during the project. This required changes to teachers' pedagogies.

### **6.3.4 Fourth phase of transformation and pedagogy: a period of altered or transformed pedagogy and the concept of precedence.**

How was the case study transformational during this later phase?



## Transformation and Pedagogy

The descriptions I have developed for transformation in the phases of my flow-logic diagram have allowed me to present the case study as a portrait of pedagogical change, one that was situated within a design & technology subject-teaching context and its usual subject knowledge precedents. I have provided evidence that suggests teachers' pedagogies were changed by the project and I have suggested mechanisms, such as where existing pedagogies were called into question and the involvement of engineers, pupils and other participant teachers in the project, that were agents of this change. Although this stops short of direct linearity between project-participation and pedagogy transformation I have argued the case for there being a strong association between the two. The strength of this argument relates to the particular design of the case study though.

### What does transformational mean?

Analysis of the interview data allowed me to develop descriptions of pedagogical transformation, ones expressed as new articulations of pedagogical precedence in relation to what the people involved in the case study were actually saying. This allowed certain relationships between pedagogy and transformation in the context of the project to be posed.

The manner of teacher's pedagogical transformations was also described from the analysis of the data, chapter 5, for example in how teachers developed new terminology to describe new pedagogical thinking which had arisen from the project. This was also consistent with the idea of teachers evidencing the beginnings of computers being known pedagogically.

### Generalisability

The ideas on transformation and pedagogy in this thesis may prove useful and generalisable at a time when transformation has become a broad aspiration and largely un-qualified goal in national dialogue on schooling (Becta 2006, 3-86). In recognising the theoretical ideas of precedence and transformation developed in this research, it may also be possible to describe new ways to embed new practices for

## Transformation and Pedagogy

teaching and learning through the use of ICT. Such an embedding could imply changes; for example to ways teachers and taught interact, their relationship to the now widespread proliferation of new kinds of ICT tools, as well as changes to responsibility and management structures resulting in school. For example, a variety of maturity modelling approaches have recently appeared (Becta matrix 2007, Underwood and Dillon 2004, 213-223) the idea being they allow the user to re-position themselves in a hypothetical change framework, or to facilitate self-evaluation and action planning. Certain principles of transformation and pedagogy elucidated in this study could help describe a generalisable relationship between change and the nature of pedagogy knowledge, one not necessarily yet recognised in professional practice modelling tools currently available, and therefore help in the design of new kinds of maturity modelling tools.

### Lessons for the development of pedagogy: how the case study and the findings might be applicable to development of design & technology as a subject

Key drivers were an intensified concern with:

- Need to complete work share component on time and to the electronically defined standard, allied with concern for possible failure and its consequences for others (in the other schools) and possible peer group pressure that would arise from within the consortium.
- Reflection and acceptance of possible change to pedagogy.

The interview data collected from this later stage in the case study was by now revealing certain questioning of prior pedagogy. This was examined in detail during chapter 5, which elaborated changes to pedagogies through analysis of the research data. A conclusion reached here was that these new pedagogy ideas resulted not from the ICT itself but from the demands of the project, which was using the ICT.

Evidence from these four phases of transformation seems to suggest that ways pedagogy knowledge arises could be considered differently to ways transformation of subject knowledge arises. This was suggesting the presence of a deeper underlying

difficulty with pedagogy and ICT, or that the impact of transformation in subject knowledge does not necessarily carry over into the same kind of impact on pedagogy.

### **6.4 KEY CONCLUSIONS ARISING FROM THE GROUNDED THEORY APPROACH AND THE FINAL FLOW-LOGIC DIAGRAM**

Behind the ideas represented by my four conceptual phases of transformation, I believe I have at least been able to develop an increasingly sharp focus on pedagogy while responding to my research questions. At best, it may be possible to consider these conceptual phases as new theory. For example, the concepts of precedence that I have described, and of the pedagogically un-preceded, could be regarded as a more generalised representation of the situated case study phenomenon of interface pedagogy. Un-preceded would become a theoretical extension of the ideas and concepts developed from the case study, ones that can also be described as teachers evidencing the beginnings of computers being pedagogically known.

These ideas lead me to conclude that, during the case study, teachers were developing certain personal reconstructions of their pedagogies in response to their pedagogical involvement in the project.

I also believe that my idea of pedagogy transformation, as described in the flow-logic diagram phases, brings interesting new thinking to this field. For example, it allows pedagogy change to be examined more as a process, having characteristics that might be influenced or supported in certain ways. My fourth phase of transformation and pedagogy, described as the period of altered or transformed pedagogy, does not imply finality or any end to the process of transformation as such. Further alterations and transformations would be an expectation in such a model, while it becomes possible to describe the earlier phases of engaging teachers in pedagogy dialogue as well as to introduce possible strategic planning to the supporting of teachers' professional development in this field.

#### **6.4.1 Ways the research supports the key conclusions.**

The key research conclusions have been evolved through ideas drawn for the

traditions of Grounded Theory, through maintaining a focus on the key research questions throughout the thesis, through analysing data from the case study and through drawing upon and developing the available literature dealing with this field.

### **6.5 RELATIONSHIP BETWEEN LITERATURE THAT HAS BEEN REVIEWED AND THE KEY RESEARCH CONCLUSIONS**

The key research conclusions are centered on the idea that teachers were shown to personally reconstruct their pedagogies when faced in certain ways with certain new pedagogy precedents during the case study. These precedents were particular to the ways the project was designed. Literature was being reviewed prior to the project, as well throughout its life, and influenced the intention in its design to more clearly understand how ICT can facilitate the transformation and pedagogy, which was my overarching research question.

Literature in the field of ICT in schools was shown to have shifted its focus from the early 1980s. Then it was largely built upon an assumption that computers and ICT could, of themselves, bring radical and useful change to learning and teaching.

The historical treatment of literature has allowed theoretical interpretations to be developed comparing different historical periods where computers were introduced, ones where ideas of precedence in pedagogical transformation could be further articulated and contextualised. For example, the early development of LOGO programming was argued to represent un-preceded knowledge arising from LOGO microworlds. Its originator (Papert 1980), gave little attention to pedagogy with computers, but introduced the idea that computers themselves could provide an escape from the teaching and liberate the learning of pupils. I have argued that from this early stage, positive assumptions about the computer's value in teaching and learning evolved, although this did not mean that their value was never questioned.

However later studies (Gardner et al.1993), were failing to detect expected learning outcomes from introducing computers into school. This perhaps reflected both a lack of transformational principles and a different (more embedding-focussed) perspective to the earlier period.

Varied writings on ICT and pedagogy were examined, using and further developing transformation principles and pre-conceptualisations during the research. It was argued that certain transformation principles developed during this project could add new depth to ideas on how teachers use and develop pedagogy (Shulman 1987, Watkins and Mortimore 1999, Sutherland et al. 2004), while the same principles allowed counter interpretations of the arguments from antagonists of computer usefulness in learning (Cuban 1993, 2001, Oppenheimer 2003), and on the willingness of teachers to change their pedagogy. The ideas of complexity in teachers' pedagogy developed from my research, compare broadly with those of Sutherland et al (2004), whose ideas were premised on socio-cultural theory and that pedagogy is socially made or constructed, while those of Scrimshaw et al (2001) gave consideration to the idea of classes of transformation that might be categorised. My own categorisation approach was further developed during the analysis of research data to help separate transformation-phenomena from non-transformation phenomena. It was shown how the climate of discovery described in the early period of literature changed to one reflecting a greater concern with embedding, one which seemed to colour the perspective of research and writing or led to traces that could be used to help develop the meaning of transformation. These later ideas on pedagogy, which have been influenced by the advance of socio-cultural theory in the later period, are useful to the idea that teachers in the case study were shown to undertake personal reconstructions of their pedagogies. Writings from this later period recommend a transformational rather than transactional interpretation of such reconstructions, while possibly placing the emphasis more on the role of social interaction than the project precedents described in my case study (Triggs and John 2004). Although such literature seems broadly consistent with my own conclusions on pedagogy reconstruction, it is possible that a social constructivist interpretation of similar phenomena would argue that the precedents were simply being socially interpreted, such as by the community of teachers, engineers and pupils in the case study. My own position here though, is that the precedents I ascribe to transformations do distinguish pedagogy transformation from other forms of teacher change, or that certain pedagogy changes can be more significant than others.

## Transformation and Pedagogy

The approach to literature in this research allowed broad interpretation of pedagogy, while suggesting connections between the level of willingness of teachers to adopt ICT transformation into their pedagogies and the historical context in which particular research writings about this was placed. This idea helped inform both the development of thinking on ICT pedagogy and on the principles developed in this research on transformation. For example, it was suggested that an early interest and impetus from transformational concerns may have been lost in the later period. Schools may have come to look to ICT to help them address other learning priorities, ones that did not necessarily centre on transformation as defined in this research, such as cost-effectiveness of investment in hardware, examination pass rates and test scores. Instead, my research is articulating the idea that encouraging pedagogy reconstruction by teachers represents evaluative and strategic investment in pedagogy and is fundamental to the idea of transformation of learning through ICT.

### **6.6 WAYS THE KEY RESEARCH CONCLUSIONS COULD CONTRIBUTE TO MORE GENERAL LESSONS FOR THE DEVELOPMENT OF PEDAGOGY**

The underlying themes used during this research are argued to be helpful in articulating more general pedagogy phenomena, as well as design & technology subject specific ones, so that pedagogy could be more closely examined. The ICT approaches in the case study allowed teachers to conceptualise a transformed design & technology knowledge and pedagogy. The analysis of data collected from the case study described how certain challenges arising from the transformation; including new pedagogical precedents, practices, theories and beliefs resulting from them; impacted on teachers' pedagogy, so allowing me to develop theory.

In describing ICT transformation as precedence in the research, together with how this phenomenon may lead to pedagogy reconstruction, the research and its ideas should also be useful in describing ways of embedding new practices for teaching and learning through the use of ICT more generally.

The new practices developed in the project concerned changes to teachers' habitual or customary procedures, such as in ways they introduced design and making challenges

## Transformation and Pedagogy

to their pupils, while the distributed nature of these challenges (pupil teams working on the same electronically defined product but from different schools) introduced new designing and manufacturing theories where new generalisations were developed to account for ways industry worked outside school. The analysis of the case study interviews revealed evidence of ways the beliefs of teachers might be changed, for example a new acceptance that pedagogically representing computers in design and manufacturing implied deeper changes to more accepted design & technology subject knowledge than had at first realised. In fact each of these; what is acceptable or customary as a procedure, the role of theories and generalisations for explaining things and certain beliefs about what is good; seem to represent more general aspects of pedagogy too.

Alongside these ideas on pedagogy this research addressed the need for deeper understanding of the nature of transformation. On the one hand this meant that certain principles of transformation could be posed, based upon ways people in the case study actually worked and learned. On the other hand this meant that any transformation of pedagogy that did take place could be described in transformational terms, ones that had emerged from the research and analysis of case study materials.

A general research conclusion, that teachers may under certain circumstances, undertake personal reconstruction of their pedagogies, has been developed in response to the 01 overarching research question 'How does ICT facilitate the transformation of pedagogy within the Eurocollaborator Project?'

The use of research ideas drawn from the traditions of Grounded Theory led to the emergence of certain transformational phases, which have been described in some detail. These phases borrow certain linearity from the definition that has been evolved for transformation itself in my research, while more flexible yet related ideas have been introduced on pedagogy rebuilding to allow a broad interpretation of pedagogy to still apply. In this way pedagogy transformation has been given a distinct interpretation, distinguishing it from other forms of teacher change that may be less significant at the present time where certain national expectations have been articulated in transformational language (Becta 2006).

While certain limitations of this research have been recognised in terms of generalisability, due to the design & technology situated context, it has also been possible to describe ways that the emerging research conclusions on transformation and teachers' pedagogy could be applied generally. For example, situations where teachers' pedagogy using ICT seems paradoxically unchanged or dysfunctional (Cuban 2001), or when an assumed transformation in subject knowledge or learning arising from ICT did not necessarily lead to an alteration in prior pedagogy, could be examined in terms of the need for personal reconstructions. I have also been able to describe this phenomenon as one where the beginnings of computers being pedagogically known by teachers came into existence in the case study.

This study confirms the idea that the nature of pedagogy learning is more complex than previously thought and warrants deeper and more sensitive analysis than may have previously been the case (Watkins and Mortimore 1999, Becta 2003). The idea that changing teacher's pedagogies involves complexity has also been explored by others (Sutherland et al. 2004). But the analysis of research data, together with the principles of transformation and pedagogy developed from it, adds new ideas and thinking to this idea of complexity. For example, ways new practices, theories and beliefs may be understood in terms of precedence. It has also been argued that a pedagogically un-preceded quality heralds pedagogical transformation, an idea that could open new lines of enquiry for supporting teachers' personal reconstructions, such as in the idea of a supporting progression in teachers' pedagogy and of the computer becoming pedagogically known.

### **6.7 WAYS THE KEY RESEARCH CONCLUSIONS MIGHT APPLICABLE TO DEVELOPMENT OF DESIGN & TECHNOLOGY AS A SUBJECT**

The idea that teachers can reconstruct their pedagogies in response to pedagogy precedents could be exploited to help develop different contexts for teaching.

In the case of design & technology there is perhaps a need to reconcile the impersonal requirements of industrial manufacturing, where personal intervention may be regarded as sources of inconsistency, with power of learning through designing and making that was first articulated by pioneers of UK design education (Eggleston et al.



## Transformation and Pedagogy

1975). Such reconciliation may need pedagogy change. An argument could be developed here that, since computers were of low significance in Eggleston's time, yet have now become key to successful industrial manufacturing, there is now a need to revise design & technology subject knowledge and to revisit pedagogy for this subject knowledge. However, making pronouncements concerning the significance of computers in manufacturing (DATA 1999), is not the same as developing pedagogy that allows teachers to develop such new thinking. This represents a deepening sophistication in pedagogy, one demonstrated throughout the case study, which might be addressed through teachers being able to reconstruct their design & technology pedagogies experientially.

During the early phases of the case study, certain time-honoured design & technology approaches continued to be used, but changed and were rebuilt when confronted with new precedents presented by the project demands and the electronic product definition of the planes. It was collaboration in building these that led to this rebuilding of pedagogies and a trust in new approaches where the product and work became electronically defined and was newly precedented.

Electronic Product Definition (Broughton et al. 1995), was therefore introduced as a transformation to the schools in ways industrial manufacturing could be represented in teaching, where manufactured products could be constructed in schools with the minimal ambiguity demanded by modern production systems. While the subject association for design & technology at that time, DATA, held the conviction that this CAD/CAM could be reflected in up-to-date subject teaching and learning (DATA, 1999), a difficulty with this idea was in the contrast between the rationale for EPD and that which had become established for design & technology teaching generally.

It was the design of the project and its management along EPD lines; or ways final planes were refined using electronic product definition, work-sharing using electronic (rather than personal) product definition, and the introduction of information that could only be provided in this way; that brought precedence to pedagogy reconstruction by teachers involved.

## Transformation and Pedagogy

The subject association dealing with design & technology (DATA) had advocated CAD/CAM as a technological change and future practice that needed to be understood by teachers and pupils during the period that the case study took place and subsequently. But advocating this stopped short of the idea that the nature of design & technology teaching should be transformed or radically altered by CAD/CAM.

The difficulty is one where there may yet be unfitness for purpose if the computer is regarded as just another kind of handicraft tool in design & technology. The benefit for design & technology would be in understanding the need for teachers undertaking personal reconstruction of their pedagogies. These reconstructions might more fully admit industrial manufacturing approaches to the still prevailing designing and making ones, while preserving the power of product ownership for pupils from earlier modes of teaching.

### **6.8 RELATIONSHIP BETWEEN THE KEY RESEARCH CONCLUSIONS AND THE RESEARCH QUESTIONS**

The idea of personal reconstruction of pedagogy by teachers arising from this research led me to the conclusion that the case study was transformational and facilitated the refinement of ideas on transformation of pedagogy.

While it was helpful to focus on certain questions at particular points during this research, it is also important to bring this thinking together into a coherent whole. This could help contribute to the current debate on composing adequate models from the increasingly complex conceptions of pedagogy and integrating these to ensure that relations between them are well described (Mortimore 1999).

The table overleaf is intended to trace ways each question in turn has been addressed:

Fig. 15 : relationship between key research conclusions and the research questions.

<b>How does ICT facilitate the transformation of pedagogy within the Eurocollaborator Project?</b>	
L1 dimension deals with ‘how can ICT transform pedagogy?’ questions.	
L2 dimension deals with ‘how ICT can change pedagogy?’ questions.	
L3 dimension deals with ‘what is meant by pedagogical transformation?’ questions.	
<b>Main question</b>	<b>Main research conclusion</b>
How does ICT facilitate the transformation of pedagogy within the Eurocollaborator project?	From analysis of evidence where teachers described change, the totality of this research suggests the change took the form of personal reconstruction of pedagogy, one where precedence had become a relevant condition to this reconstruction.
<b>Sub-question</b>	<b>How each was addressed</b>
L1.1 What is meant by transformation in the context of the Eurocollaborator project?	The research began from the viewpoint that the Eurocollaborator project was transformational in that it placed teachers and learners in new contexts, which require pedagogical rethinking – these contexts became referred to in terms of precedence. The analysis of data from the case study went on to show how teachers could evolve new pedagogical practices, theories, and beliefs and to describe how these came about. The meaning of transformation has been consistently examined and developed throughout each chapter of the thesis.
L1.2 What processes of transformation, if any, arose from new Information and Communication Technology approaches learned from the aerospace industry?	The project was co-managed by the UK aerospace industry, BAE SYSTEMS, who helped introduce current industry practices used by their European plane-manufacturing consortia. The Eurocollaborator consortia (of schools) then designed and built scale models of single aircraft from distributed school sites over a 2-year period. Methods of designing and constructing the components of these scale models were dependent upon computer aided means, including computer aided design and manufacture (CAD/CAM) and Electronic

	<p>product definition (EPD) for communication between the schools. These computer-aided means helped introduce the key processes of transformation, described in this research in terms of precedence. The argument for this being so has been developed throughout each chapter of the thesis.</p>
<p>L1.3 How did this influence the pedagogy of teachers involved in the case study?</p>	<p>The Eurocollaborator participants worked together within a transformational framework, one involving teachers, pupils and aerospace engineers from different school and factory locations working together on single products. The case for this being transformation was carefully formulated and tested throughout the research, leading to conclusions that deal with new contexts or precedents and the new practices, theories and beliefs which developed. Certain interactions within the project, including ways teams in different school locations became dependent on each other, caused existing pedagogies to be called into question and led to a process that has been described as personal reconstruction of pedagogy within the main research conclusion. The argument for this being so has been developed throughout each chapter of the thesis, where ideas and traditions drawn from Grounded Theory were applied to the analysis of the research data.</p>
<p>L2 In what ways, if any, has ICT helped to change or alter learning and pedagogy?</p>	<p>The particular uses of ICT, rather than the ICT itself, helped develop transformations of more usually preceded design &amp; technology teaching and learning. For example, pupils had to learn that their particular aircraft concept was being ‘jointly’ rather than ‘individually’ developed, involved others in different schools and who worked with other teachers. Daily decisions in each school impacted not only on the ‘in-school’ work of the team but of the ‘distributed-consortium’ because the Eurocollaborator consortium required a ‘work-shared’, rather than individual, ‘design and make’ approach. This form of collaboration</p>

	<p>between the participants represented new precedents, ones that stimulated new kinds of learning and personal reconstructions of teacher pedagogy. The argument for this being so has been developed throughout the thesis.</p>
<p>L3.1 How did working and collaborating with other schools during the project affect the learning and pedagogy of those who took part?</p>	<p>A driving force behind the particular collaborative learning in Eurocollaborator can also be described in socio-cultural terms where teachers and engineers formed communities of learners based on taking account of each other's perceptions of what was actually taking place in the classroom and what constituted improved learning. This was evidenced through the collaborative nature of the aircraft design and manufacture. The argument for this being so has been developed throughout the thesis.</p>
<p>L3.2 What evidence was there that designing and manufacturing with an electronically defined product (as different to more conventional 'design and make' design &amp; technology approaches) had any particular influence on learning and pedagogy?</p>	<p>Because teams of pupils and teachers in groups of secondary schools, rather than individuals working on their own design &amp; technology projects, designed and manufactured single products in distributed yet collaborative ways, the more usual designing and making approaches proved insufficient for successful manufacture and assembly. The consortia groups were assisted, by computer-aided means, to overcome the difficulty of working in this collaborative and distributed way. In coming to depend on this new approach to design &amp; technology, one that had been borrowed from the aerospace manufacturing industry, the participants encountered new precedents, which challenged their prior ways of working. The evidence for these changes to learning and pedagogy was provided through analysis of the data and the application of approaches that drew from traditions of Grounded Theory. This led me to the conclusion that teachers who had been interviewed were describing how they undertook personal reconstruction of pedagogy in response to their experiences within the project.</p>

<p style="text-align: center;">L3.3</p> <p>What else could be said about ways that the project was used in the classroom?</p>	<p>Ways the project was used in the classroom allowed deeper understanding of principles of transformation, a new perspective to be brought to literature on ICT in education and a deepening understanding of pedagogy and teachers' thinking.</p> <p>The argument for this being so has been developed throughout the thesis and as a possible theoretical extension of these ideas beyond the situated design &amp; technology context.</p>
---	--

**Fig. 15, source: author**

## 6.9 CONCLUDING REMARKS

During this research I have attempted to develop theory about transformation alongside a discourse on pedagogy with ICT. Transformation and pedagogy have been treated as related, but different ideas, the effect of one on the other is argued to be more complex than perhaps it at first seems. Although I have been careful to avoid implying pedagogy-linearity while using a phases approach, one influenced by traditions that derive from Grounded Theory, I also conclude that there does seem to be a kind of linearity in transformation itself. For example, a transformation seems to imply a change or transference from an earlier pre-transformation condition. The historical analyses in this study also suggest that such earlier pre-transformation conditions may themselves have been believed to be transformations from within their earlier historical contexts. For example, the innovative ideas of Eggleston (1975) were at the heart of the newly developing practices, theories and beliefs that characterised the birth of design & technology as a subject in the late 1970s. These might be argued to represent a transformation emerging from earlier technical education practices that were common in schools prior to then. It is possible to describe certain aspects of the case study as post-Egglestonian and transformational, albeit from a later historical context, therefore implying a kind of linearity. However, the same linearity cannot be said to simply apply to the teacher's pedagogy, which is of a deeper complexity (Watkins and Mortimore 1999). This complexity will include such as the individual teacher's style of teaching, the varied possible types of classrooms and complex interactions of teachers and pupils, different conceptions of learners based upon our current understanding of cognition and metacognition as well as different models of

## Transformation and Pedagogy

pedagogy. I have however extended these ideas to take account of multiple classrooms and schools in my case study. It has also been argued that national policy and political perspectives are introducing yet further new and different levels of complexity in pedagogy knowledge (Mortimore 1999). Given such complexity, linearity attributed to a transformation process would be unlikely to pass directly to pedagogy although certain underlying themes have been suggested as relevant, such as transfer from a pre-transformation condition.

The case study, developed from within the Eurocollaborator project, allowed the research to describe how a prior pedagogy was brought to bear upon a new purpose, one described as transformation, together with analysis of the issues and difficulties of pedagogical precedence that this brought about. This also allowed relationships between transformation and pedagogy to be more fully understood and analysed, suggesting ways new principles could be developed for examining pedagogy-learning.

It is hoped that my main research conclusion, the idea that precedence may predicate teachers undertaking personal reconstruction of their pedagogies, is a useful contribution. By focussing on the meaning of such reconstruction, together with its manner and circumstances, the debate on how technological transformations can lead to pedagogical ones will be enriched.

## REFERENCES

Aylward, B. (1975), Design in general education, Summer School Report, Royal College of Art, Great Britain, London, Royal College of Art, 15-17.

Ayscough, P. B. (1977), CALChemistry, British Journal of Educational Technology, London, Council for Educational Technology, (8), 201-213.

Banks, F., Leach, J., and Moon, B. (1999), New understanding of teacher's pedagogic knowledge, in: J. Leach and B. Moon, Learners and Pedagogy, Great Britain, London, Paul Chapman.

Barclay, I. and Lunt, P. J. (1985), Successful management of the introduction of new technology, in: J. Bessant, Management and Manufacturing Innovation in The United Kingdom and West Germany, Gower, 81-86.

Cox, M., Webb, M., Abbott, C., Blakely, B., Beauchamp, T. and Rhodes, V. (2003), ICT and pedagogy, a review of the research literature, Becta, ICT in Schools Research and Evaluation Series, Great Britain, HMSO, (18), 12.

Becta (British Educational Communications and Technology Agency), NGfL (National Grid for Learning), DfES (Department for Education and Skills) (2001), ImpaCT2, emerging findings from the evaluation of the impact of information and communications technologies on pupils' attainment, NGfL Research and Evaluation Series, Great Britain, HMSO, 1-16.

Becta (British Educational Communications and Technology Agency) (2005), The Becta review (2005), evidence on the progress of ICT in education, Becta ICT Research, Coventry/ London, Becta/ DfES.

Becta (British Educational Communications and Technology Agency) (2006), Educational change and ICT: an exploration of priorities 2 and 3 of the DfES e-strategy in schools and colleges, the current landscape and implementation issues, Becta, ICT Research, Coventry/ London, Becta/ DfES.

Becta (British Educational Communications and Technology Agency) (2007), Becta matrix 92007, Coventry.  
<http://matrix.becta.org.uk/> (Accessed 10 August 2007).

Becta (British Educational Communications and Technology Agency), (2006), Learning Platform Framework Agreement, 2.0, Procurement Overview, Coventry/ London.  
<http://becta.org.uk/> (Accessed 10 August 2007).

Bell, R. and Bell, L. (2003), A bibliography of articles on technology in science education, in: Contemporary Issues in Technology and Teacher Education, (2), 427-447.



## Transformation and Pedagogy

BERA (2004), Revised Ethical Guidelines for Educational Research, British Educational Research Association.

Birmingham, P. and Davies, C. (2001), Storyboarding Shakespeare: learner's interactions with storyboard software in the process of understanding difficult literary texts, Journal of Information Technology for Teacher Education, (10), 241-253.

Black, T. R. (1999), Doing Quantitative Research in Social Sciences, London, Sage Publications, 7, 9, 3-26.

Boyle, M. (1998), Has Minsky anything to say about education?, Journal of Computer Assisted Learning, Blackwell Publishing Ltd., (14), 260-267.

Brewster, J. (1991), Do I have to do it from my mind? International strategies in task-based group work, in: C. Kennedy and J. Jarvis, Ideas and Issues in Primary ELT, Nelson in association with CfBT (Centre for British Teachers).

Bromme, R. (1995), What exactly is pedagogical content knowledge? Critical remarks regarding a fruitful research program, in: S. Hopmann and K. Riquarts, Didaktik and/ or Curriculum, Kiel: IPN, 125.

Bromme R. (1987), Teacher's assessments of students' difficulties and understanding in the classroom, in: J. Calderhead, Exploring Teacher's Thinking, Cassell education.

Broughton, T., Manton, S. and Puttick, J. (1995), The Time-to-Market Machine, How EPD is Changing the Face of Manufacturing, Great Britain, Bedford, Computervision Corporation, 20-31, 53.

Bruner, J. (1996), The Culture of Education, America, Harvard University Press.

Bryman, A. (1998), Quantity and Quality in Social Research, London, Unwin Hyman.

Bryman, A. and Burgess, R. G. (1994), Analyzing Qualitative Data, America, Routledge.

Bullock, A. (1975), The Bullock Report, a language for Life, Great Britain, HMSO.

Burgess, R. G., Pole, C. J., Evans, K. and Priestley, C. (1994), Four studies from one or one study from four? Multi-site case study research, in: A. Bryman and R. G. Burgess, Analyzing Qualitative Data, New York, Routledge, 129-146.

Burton, D. (2000), Research Training for Social Scientists, London: Sage.

Calderhead, J. (1987), Exploring Teacher's Thinking, Great Britain, London, Cassell, 5.

Carter, K. and Doyle, W. (1987), Teachers' knowledge structures and comprehension processes, in: J. Calderhead, Exploring Teachers' Thinking, Great Britain, London, Cassell, 146-160.

## Transformation and Pedagogy

Clements, D. H. (2000), From exercises and tasks to problems and projects - unique contributions of computers to innovative mathematics education, Journal of Mathematical Behaviour, (19), 9-47.

Coffey, A., Atkinson, P. (1996), Making sense of qualitative data, Complimentary Research Strategies, California, Sage, Thousand Oaks, 164-187.

Cohen, E. G. and Manion, L. (1994), Restructuring the classrooms: conditions for productive small groups, Review of Educational Research, (1), 1-35, 64.

Cohen, L., Manion, L., Morrison, K. (2000), Research Methods in Education (4<sup>th</sup> edition), London, Routledge, 241-244, 281-282.

Colbourne, J. & Light, P. (1987), Social interaction and learning using micro-PROLOG, Journal of Computer Assisted Learning, Blackwell Publishing Ltd., (3), 130-141.

Cole, M. J., V. John-Steiner, S. Scribner, E. Souberman (1978), Mind and Society: The Development of Higher Psychological Processes, Harvard University Press, 121-131.

Cox, M. (2000), Information and communications technologies: their role and value for science education, Good Practice in Science Teaching, 12, 190-206.

Cox, M., Webb, M., Abbott, C., Blakely, B., Beauchamp, T. and Rhodes, V. (2003), (2003), ICT and pedagogy, a review of the research literature, Becta, ICT in Schools Research and Evaluation Series - No. 18, Coventry/ London, Crown Copyright, HMSO.

<http://publications.becta.org.uk/display.cfm?resID=25813> (Accessed 8 October 2007)

Clark, C. M. and Yinger, R. J., (1987), Teacher planning, in: J. Calderhead, Exploring Teacher's Thinking, Great Britain, London, Cassell, 84-85, 88, 89, 93, 95.

Creswell, J. W. (1998), Qualitative Enquiry and Research design: Choosing among Five Traditions, California, Thousand Oaks, London, Sage, 129-191.

Crook, C. (1987) Computers in the Community of Classrooms, in: J. Rutkowska, Computers, Cognition and Development : Issues for Psychology and Education, Wiley, 103-111.

Cuban, L. (1993), Computers meet classroom – classroom wins, Teachers' College Record, (2), 95, 185-210.

Cuban, L. (1997), Teaching with Technology, creating student-centred classrooms, in: J. H. Sandholtz, C. Ringstaff, D. C. Dwyer, New York, Teachers' College Press, the forward.

Cuban, L. (2001), Oversold and Underused: Computers in The Classroom, Harvard University Press, 14-16.

Cummings, R. (1985), Small group discussions and the microcomputer, Journal of Computer Assisted Learning, Blackwell Publishing Ltd., (1), no. 3.

DATA (The Design & Technology Association), (1999), Teaching CAD/CAM, Great Britain, Wellesbourne, The Design and Technology Association, 3-9, 12.

DCSF (Department for Children, School and Families), (2009), Standards for Advanced Skills Teacher Scheme, Great Britain, Crown Copyright, HMSO.  
<http://www.standards.dfes.gov.uk/ast/>

de Jong, T., van der Hulst, A. (2002), The effects of graphical overviews on knowledge acquisition in hypertext, Journal of Computer Assisted Learning, Blackwell Publishing Ltd., 219-231.

de Jong, T., van Jooligen, W. R., Swaak, J., Veermans, K., Limbach, R., King, S., Gureghian, D. (1998), Self directed learning in simulation-based discovery environments, Journal of Computer Assisted Learning, Blackwell Publishing Ltd., (14), 235-246.

Denzin, N.K. (1997), in: J.P. Keeves, Educational Research, Methodology and Measurement: an International Handbook, (2<sup>nd</sup> edition), Oxford, Pergamon, 318-322.

DfES (Department for Education and Skills) (2002), Survey of Information and Communications Technology in schools, London: DfES.

Dewey, J. (1902), The child and the curriculum, in: J. A. Boydston, The Relation of Theory to Practice in the Education of Teachers, Third Handbook, The National Society for the Scientific Study of Education, Part 1, Bloomington, IL: Public School Publishing.

DfES (Department for Education and Science) (1995), National Curriculum Guidance for the National Curriculum Order, Great Britain, London, Crown Copyright, HMSO. 4c.

DfES (Department for Education and Science), (1990), National Curriculum Order, Great Britain, London, Crown Copyright, HMSO.

Dillenbourgh, P. (1996), The Evolution of Research on Collaborative Learning.  
<http://www.uib.no/People/sinia/CSCL/webstruktur-958.htm> (Accessed 2 August 2007).

Easterton, D. (1985), The management of computing resources in schools, Journal of Computer Assisted Learning, Blackwell Publishing Ltd., (1), 134-148.

Eggleston, J. (1974), You Are a Designer, London, Edward Arnold for Schools Council Publications.

Eggleston, J. (1975), Education Through Design & Craft, The Schools Council Design & Craft Education Project, London, Edward Arnold for Schools Council Publications, 3, 20-26.

Fang, Z. (1996), A review of research on teacher beliefs and practices, Educational Research, 38, 47-64.

Fielding, N. G., Lee, R. M. (1998), Computer Analysis and Qualitative Research, London, Sage, 57-85.

Finniston, M. (1980), Engineering our Future: report of the committee of inquiry into the engineering profession, Finniston Report, Great Britain, HMSO.

Freeman, D., Tagg, W. (1985), Databases in the classroom, (the advisory unit for computer based education at Hatfield), Journal of Computer Assisted Learning, Blackwell Publishing Ltd., (1), 1.

Gardner, J., Morrison, H., Jarman, R., Reilly, C. & McNally, H. (1992), Pupil's Learning and Access to Information Technology: an Evaluation, Belfast, The School of Education, Queens University.

Gardner, J., Morrison, H., & Jarman, R. (1993), The impact of high access to computers on learning, Journal of Computer Assisted Learning, Blackwell Publishing Ltd., (9), 2-16.

Gibson, J. (1979, 1986), The Ecological Approach to Visual Perception, New Jersey, Hillsdale, Lawrence Erlbaum Associates, 128-135.

Giroux, H. A. (2003), in: A. Darder, M. Baltodano and R. D. Torres, The Critical Pedagogy Reader, New York, Routledge Falmer, London, 27-28.

Glesne, L. and Peshkin, A. (1992), Becoming Qualitative Researchers: An Introduction, New York; Longman.

Glover, D. & Millar, D. (2001), Running with Technology, the pedagogic impact of the large scale introduction of interactive whiteboards in one secondary school, Journal of Information Technology for Teacher Education, (10), 257-278.

Goldstein S. (1997), Ofsted Report on IT Use in Secondary Schools, 1995-7, London, HMSO.

Goodyear, P. (1987), LOGO: Some areas of difficulty in assessing the cognitive effect of learning to program, Journal of Computer Assisted Learning, Blackwell Publishing Ltd., (3), 214-223.

Harrison, J. (1967-72), Project Technology, Great Britain, Loughborough College of Education, The School's Council.

Hawkrige, D. (1990), Who Needs Computers in Schools and Why?, Computers and Education, Pergamon Press, (15), 1-6.

Hay McBer (2000), Research into Teacher Effectiveness: a model of teacher effectiveness, London, Department for Education and Employment, 1-11.

Hayward, B.W. and Bessant, J. (1985), The implications of integrated technology for manufacturing engineering strategy, in: Management and Manufacturing innovation in the United Kingdom and West Germany, Gower, 297-303.

Hennessey, S., Deaney, R., Ruthven, K. (2002), Pedagogic strategies for using ICT to support subject teaching and learning: an analysis across 15 case studies, Research Report No. 03/1, Great Britain, University of Cambridge Faculty of Education, 2-36.

Heppell, S. (1993), Teacher education, learning and the information generation: the progression and evolution of educational computing against a background of change, Journal of Information Technology for Teacher Education, (2), 233, 229-37.

Hirshhorn, L. (1984), Robots Can't Run Factories, from Beyond mechanisation: Work and technology in the post-industrial Age, Wharton Centre for Applied Research, University of Pennsylvania, Hodder & Stoughton.

Hoyles, C. & Sutherland, R. (1987), Ways of learning in a computer based environment: some findings of the LOGO maths project, Journal of Computer Assisted Learning, Blackwell Publishing Ltd., (3), 67-81.

Hoyles, C. (2001), Steering Between Skills and Creativity: a role for the computer, for the learning of mathematics, Journal of Computer Assisted Learning, Blackwell Publishing Ltd., (21), 33-39.

Hoyles, C. and Sutherland, R. (1989), Designing a LOGO-based microworld for ratio and proportion, Journal of Computer Assisted Learning, Blackwell Publishing Ltd., (5), 208-222.

Hoyles, C., Healey, L., Pozzi, S. (1994), Groupwork with computers : an overview of findings, Journal of Computer Assisted Learning, Blackwell Publishing Ltd., (10), 202-215.

Huitt, W., Hummel, J. (2003), Piaget's theory of cognitive development, Educational Psychology Interactive.  
<http://chiron.valdosta.edu/whuitt/col/cogsys/piaget.html> (Accessed 4th December 2007), 1-5.

Jackson, A., Fletcher, B. C., Messer, D. J. (1986), A survey of microcomputer use and provision in primary schools, Journal of Computer Assisted Learning, Blackwell Publishing Ltd., (2), 45-55.

Janesick, V. J. (2000), The choreography of qualitative research design, in: N.K. Denzin, and Y.S. Lincoln, Handbook of Qualitative Research, London: Sage, 379-401.

## Transformation and Pedagogy

Jimoyiannis, A., Komis, V. (2001), Computer simulations in physics teaching and learning: a case study on student's understanding of trajectory motion, Computers & Education, (36), 183-204.

John-Steiner, V., Mahn, H., Sociocultural approaches to learning and development: a Vygotskian framework, Educational Psychologist, 31 (3/4), 198.

John, P. D. (2004), Teaching and Learning with ICT, New Technology, New Pedagogy?, Graduate school of Education, University of Bristol.

Johnson, D. C., Cox, M. J., Watson, D. M. (1994), Evaluating the impact of IT on pupil's achievements, Centre for Educational Studies, Kings College London, Journal of Computer Assisted Learning, Blackwell Publishing Ltd., (10), 138-156.

Jones, A. (2002), ICT and learning theories: Preparing pre-service teachers for the classroom, Annual Conference of the British Educational Research Association, University of Exeter, Great Britain, 1-7.

Kapa, E. (1999), Problem Solving, planning ability and sharing processes with LOGO, Journal of Computer Assisted Learning, Blackwell Publishing Ltd., (15), 73-84.

Katterns, R., Haigh, N. (1986), The effective teacher and computers, Journal of Computer Assisted Learning, Blackwell Publishing Ltd., (2), 162-173.

Keeves, J. P. (1997), Educational research, Methodology and Measurement. An International Handbook, (2<sup>nd</sup> edition), Oxford, Pergamon, 61.

Keith-Lucas, D. (1980), chairman's forward, in: Design Education at Secondary Level, The Design Council, London, 2. (working party on secondary education set up by the Education Committee of the Design Council in 1978. It had been preceded by 'Engineering Design Education' (1976) chaired by Dr Alex Moulton and by 'Industrial Design Education in the United Kingdom in 1977, chaired by David Carter).

Kimball, R. (2002), Footprints in Shifting Sands, ten years of editorial from DATA Journal, 1996-2005, London, The Design & Technology Association, 73-76.

King, R., Iacono, S. (1988), Desktop computerisation and the organisation work, in: R. Gordon, L. Kimball, High Technology-Industrial, Regional and Social Transformations, New Jersey, Ablex, Norwood, 351-352.

Kozma, R. B., Anderson, R. E. (2002), Qualitative case studies of innovative pedagogical practices using ICT, Journal of Computer Assisted Learning, Blackwell Publishing Ltd., (18), 387-394.

Kramarski, B., Hirsch, C. (2003), Using computer algebra systems in mathematical classrooms, Journal of Computer Assisted Learning, Blackwell Publishing Ltd., 35-45.

## Transformation and Pedagogy

Lawler, R. W. (1987), Designing computer based microworlds, in: Learning with Computers, Great Britain, Intellect Books.

Leach, J. and Moon, B. (1999), Learners and Pedagogy, Great Britain, The Open University, Paul Chapman Publishing, 265-267, 267-275.

Lecllet, D., Werdenfeld, G. (1998), Training for strategic decision making in professional contexts, Journal of Computer Assisted Learning, Blackwell Publishing Ltd., (14), 140-147.

Lewis, R. (2002), Editorial: the impact of ICT on learning, Journal of Computer Assisted Learning, Blackwell Publishing Ltd., (18), 1.

Lewis, R. (2003), Editorial: changing times, Journal of Computer Assisted Learning, Blackwell Publishing Ltd., (19), 1.

Light, P., Littlejohn, K., Messer R. J. (1994), Social and communicative processes in computer-based problem solving, European Journal of Psychology of Education, (9), 93-109.

Lincoln, Y. S., Guba, E. (1985), Naturalistic Enquiry, Beverly Hill USA, Sage, 289-291.

Lowenthal, F., Marcourt, C., Solimando C. (1998), Journal of Computer Assisted Learning, Blackwell Publishing Ltd., (14), 130-139.

Mason, J. (1994), Linking qualitative and quantitative data analysis, in: A. Bryman, R. G. Burgess, Analyzing Qualitative Data, New York, Routledge, 103-4.

McCormick, R., Scrimshaw, P. (2001), Information and Communications Technology, knowledge and pedagogy, Education, Communication and Information, (1), 48-52, 30, 37-38, 48-52, 50-51.

McLoughlin, C., Oliver, R. (1999), Pedagogic roles and dynamics in telematics environments, in: M. Selinger, J. Pearson, Telematics in Education: Trends and Issues, Oxford, Elsevier Science, 32-50.

Morrison, K. (1993), Planning and Accomplishing School-centred Evaluation, London, Francis.

Mortimore, P. (1999), Understanding Pedagogy and its impact on learning, London, Paul Chapman, Sage, 3-15.

Moser, C., Kalton, G. (1971), Survey Methods in Social Investigation, (2<sup>nd</sup> edition), Great Britain, Aldershot, Gower.

Mumtaz, S., Hammond, M. (2002), The word processor revisited : observations of the use of the word processor to develop literacy at key stage 2, British Journal of Educational Technology, (33), 345-347.

## Transformation and Pedagogy

- Noss, R. (1987), How do children do maths with LOGO?, Journal of Computer Assisted Learning, Blackwell Publishing Ltd., (3), 2-12.
- Noss, R., Pachler, N. (1999), The challenge of new technologies: doing old things in the new way, or doing new things?, in: P. Mortimore, Understanding Pedagogy and its impact on learning, 195-201.
- Olson J. K., Eaton S. (1987), Curriculum change and the classroom order, in: J. Calderhead, Exploring Teacher's Thinking, Cassell education, 179, 180, 186-189, 193.
- O'Shea, T., Self, J. (1983), Learning and Teaching with Computers, Artificial Intelligence in Education, Harvester.
- OfSTED (Office for Standards in Education), (2002), Information and Communication Technology in secondary schools, Ofsted Subject Reports Series 2001/02, HMI 819, London: Her Majesty's Inspectorate, 7-11.
- OfSTED (Office for Standards in Education), (2001), New Opportunities Funded NOF ICT training scheme, HMI 264 Interim Report and the impact of the scheme on teachers, London, Her Majesty's Inspectorate.
- Okely, J. (1994), Thinking through fieldwork, in: A. Bryman and R. G. Burgess, Analyzing Qualitative Data, New York, Routledge, 24.
- Oppenheimer, T. (2003), The Flickering Mind: The False Promise of Technology in the Classroom and How Learning Can be Saved, New York, Random House, 5-7, 67-69.
- Oxford University (2009), Compact Oxford English Dictionary on-line, free dictionary, Oxford University Press.  
[http://www.askoxford.com/dictionaries/compact\\_oed/?view=uk](http://www.askoxford.com/dictionaries/compact_oed/?view=uk) (Accessed 15/002/09)
- Papert S. (1993), Mindstorms : Children, Computers and Powerful Ideas, (2<sup>nd</sup> edition), New York, London, Harvester, 3-13, 217.
- Papert, S. (1980), Mindstorms: Children, Computers and Powerful Ideas, Brighton, Harvester, 120-135, 135-156, 217.
- Papert, S. (1993), The Children's Machine: Rethinking School in the Age of the Computer, New York, Basic Books, 137-156, 82, 139.
- Piaget, J. (1972), The Psychology of The Child, New York, Basic Books.
- Reynolds, D., Treharne, D. & Tripp, H. (2003), British Journal of Educational Technology, (34), 151-167.
- Richards L., Richards T. (1994), From filing cabinet to computer, in: A. Bryman, R. G. Burgess, Analyzing Qualitative Data, New York, Routledge, 146-173.



## Transformation and Pedagogy

Ritz, J.M., Hadley, F. H., Bonebrake J. (1990), Exploring Production Systems: Processing, Construction, Manufacturing, Massachusetts U.S.A., Davis Publications Inc., 11.

Rogers, R. (1980), Crowther to Warnock, How Fourteen Reports Tried to change Children's Lives, Heineman.

Roschelle, J. (2003), Unlocking the learning value of wireless mobile devices, keynote paper, Journal of Computer Assisted Learning, Blackwell Publishing Ltd., (19), 260-272.

Royal College of Art (1975), Design in General Education, Summer School Report, Great Britain: Royal College of Art.

Royal College of Art Schools Technology Project, (1999), Advanced Manufacturing Design, Great Britain, Hodder & Stoughton.

Royal College of Art Schools Technology Project, (1995), D&T Challenges, KS3, Hodder & Stoughton.

Royal College of Art Schools Technology Project, (1996), Teachers' Resource for KS4, Great Britain, Hodder & Stoughton.

Salovaara, H. (2005), An exploration of students' strategy use in inquiry-based computer-simulated collaborative learning, Journal of Computer Assisted Learning, Blackwell Publishing Ltd., 39-52.

Sandholtz, J. H., Ringstaff, C., Dwyer, D. C. (1997), Teaching with Technology, creating student-centred classrooms, New York , Teachers' College Press.

Sandholtz, J. H., Ringstaff, C., Dwyer, D. C. (2002), The Impact of Technology on Student Achievement: A Summary of Research Findings on Technologys Impact in the Classroom.

<http://www.apple.com/education/research/> (Accessed 21<sup>st</sup> October 2007).

Schön,D. A. (1987), Educating the reflective practitioner: toward a new design for teaching and learning professions, San Francisco, California, Jossey-Bass.

Schools Council (1974), Education Through The Use of Materials, London, Evans Bros.

Schools Council (1974), Children's Growth Through Creative Experience, Art and Craft Education 8-13, London, Goldsmith's College, Van Nostrand Reinhold Company Ltd, 9, 14, 16-19.

Schools Council (1974), Materials and Design: A Fresh Approach, London, Edward Arnold, 7-24.

Schools Council (1974), You are a Designer, London, Edward Arnold.

## Transformation and Pedagogy

Self, J. (1985), Microcomputers in Education: a Critical Evaluation of Educational Software, Harvester.

Self, J. (1985), A perspective on intelligent computer assisted learning, Journal of Computer Assisted Learning, Blackwell Publishing Ltd.

Shaiken, H. (1985), Work Transformed: Automation and Labor in the Computer Age, Holt, Reinhart and Winston, 137-226.

Shulman, L. (1986), Those who understand: knowledge growth in teaching, Educational Researcher, 15 (2), 4-14.

Shulman, L. (1987), Knowledge and teaching: foundations of the new reform, Harvard Educational Review, 57.

Simon, B. (1999), Why no pedagogy in England?, in: J. Leach, B. Moon, Learners and Pedagogy, Great Britain, Paul Chapman, The Open University, 37, 34-48.

Silverman, D. (2000), Doing Qualitative Research, London, Sage.

Siraj-Blatchford I. and Siraj-Blatchford J. (2006), TOWARDS A FUTURE EARLY YEARS ICT CURRICULUM, in: ICT in the Early Years, Hayes M. and Whitebread D. (eds.), Open University Press.

Smith, C. D. (1986), Learning LOGO : effects on learning BASIC and statistics, Journal of Computer Assisted Learning, Blackwell Publishing Ltd., (2), 102-109.

Somekh, B., Davies, R. (1991), Towards a Pedagogy for Information Technology, The Curriculum Journal, (2), 153-167.

Sparkes, R. A. (1982), Microcomputers in Science Teaching, Great Britain, Archer Press, 8, 11, 15, 103.

Stake, R. E. (1994), Case Studies, in: N. K. Denzin and Y. S. Lincoln, Handbook of Qualitative Research, London, Sage Publications.

Stake, R.E. (1995), The Art of Case Study Research, Thousand Oaks, Sage Publications.

Strauss, A., Corbin, J. (1998), Basics of Qualitative Research: Techniques and Procedures for Developing Grounded Theory, California, Thousand Oaks, Sage Publications, 11-12, 12-14, 15-25, 55-87, 73-85, 103-110, 138.

Strauss, A. L., Corbin, J. (1990), Basics of Qualitative Research, Grounded Theory Procedures and Techniques, California, Newbury Park, Sage Publications, 23-32, 108-109, 154, 252-258, 268-270.

Sturman, A. (1997), Case study method, in: J. P. Keeves, Educational Research, Methodology and Measurement: An International Handbook (2<sup>nd</sup> edition), Oxford, Pergamon.

Subhi, T. (1999), The impact of LOGO on gifted children's achievement and creativity, Journal of Computer Assisted Learning, Blackwell Publishing Ltd., (15), 98-108.

Sutherland R., Armstrong V., Barends S., Brawn R., Breeze N., Gall M., Matthewman S., Oliver F., Taylor A., Triggs P., Wishart J., John P. (2004), Journal of Computer Assisted Learning, (special edition), Blackwell Publishing Ltd., (20), 413-425.

Sutherland, R., Robertson, S., John, P. (2004), Interactive Education: teaching and learning in the information age, Journal of Computer Assisted Learning, Great Britain, Blackwell Publishing Ltd., (20), 410-412.

Teacher Training Agency (1998), The Use of ICT in subject teaching, Expected outcomes for Teachers in England, Northern Ireland & Wales, London, The Teacher Training Agency, 7-16, 17-31.

Tesch, R. (1990), Qualitative Research: Analysis Types and Software Tools, London, Falmer Press, 77-107.

Thomas, S. (1980), Review of Design Council's Design Education at Secondary Level, (press comment, available from author).

Triggs, P., John, P. (2004), From transaction to transformation: information and communication technology, professional development and the formation of communities of practice, Journal of Computer Assisted Learning, Blackwell Publishing Ltd, (20), 426-439.

Turner, B. A. (1994), Patterns of crisis behaviour: a qualitative inquiry, in: A. Bryman, R. G. Burgess, Analyzing Qualitative Data, New York, Routledge, 195-216.

Tweddle, S. (1997), A retrospective: 15 years of computers in education, English in Education, (31), 4-12.

Twigger, D., Byard, M., Draper, S., Driver, R., Hartley, R., Hennessy, S., Mallen, C., Mohamed, R., O'Malley, C. O., O'Shea, T., Scanlon, E. (1991), The 'conceptual change in science project', Journal of Computer Assisted Learning, Blackwell Publishing Ltd., (7), 144-155.

Underwood, J. (2004), Research into Information and Communications Technologies: where now?, Technology, Pedagogy and Education, Blackwell Publishing Ltd., (13), 135-142.

Underwood, J., Dillon, G. (2004), Capturing complexity through maturity modelling, Technology, Pedagogy and Education, Blackwell Publishing Ltd., (13), 213-223.

University of Bristol (2004), Interactive Education Project.  
<http://www.interactiveeducation.ac.uk> (Accessed 2<sup>nd</sup> April 2007).

## Transformation and Pedagogy

Verma, G. K., Mallick, K. (1999), Researching Educational Perspectives and Techniques, London, Falmer Press, 3-12, 27, 115, 123.

Vygotsky, L. S. (1962), Thought and Language, Cambridge, MA: MIT Press.

Wagner A. C. (1987), Knots in teacher's thinking, in: J. Calderhead, Exploring Teacher's Thinking, Cassell education, 170.

Walker, R. (1985), Doing Research : A Handbook for Teacher, London, Routledge, 119, 130-131.

Watkins, C. & Mortimore, P. (1999), Pedagogy: what do we know?, in: P. Mortimore, Understanding Pedagogy and Its Impact on Learning, London: Paul Chapman, 3, 1-19.

Webb, M., Cox, M. (2004), A review of pedagogy related to Information and Communications Technology, Technology, Pedagogy and Education, (13), 235-282.

Webb, M. E. (2002), Pedagogical reasoning: issues and solutions for the teaching and learning of ICT in secondary schools, Education and Information Technologies, Kluwer Academic Publishers, (7:3), 237-255.

Wenger, E. (1999), Communities of Practice : Learning, Meaning and Identity, Cambridge University Press, 55-57.

Wilson, S. M., Shulman L. S. & Richert A. E., (1987), 150 different ways of knowing: representations of knowledge in teaching, in: J. Calderhead, Exploring Teacher's Thinking, Cassell education, 105, 107, 104-120.

Wright, R. T. (1990), Manufacturing Systems, Students' Book, Indiana, Ball State University, The Goodheart-Wilcox Company, 73.

Yelland, N. J. (1994), The strategies and interactions of young children in LOGO tasks, Journal of Computer Assisted Learning, Blackwell Publishing Ltd., (10), 33-49

Yin, R.K. (1993), Applications of Case Study Research, California, Thousand Oaks, Sage Publications, 4, 12-13, 39-40, 44, 66, 72-75.

Yin, R. K. (1989), Case Study Research: Design and Methods, (1<sup>st</sup> edition), Thousand Oaks, CA: Sage Publications, 94-98.

Yin, R. K. (1993), Applications of Case Study Research, Applied Social Research Methods, Sage, 34.

Yin, R. K. (1994), Case Study Research: Design and Methods, (2<sup>nd</sup> edition), California, Thousand Oaks, Sage Publications, 1-15, 33, 36-38, 84-86.

Zeichner, K. M., Tabachnick, B. R., Densmore K. (1987), Individual, instructional, and cultural influences on the development of teacher's craft knowledge, in: J. Calderhead, Exploring Teacher's Thinking, Cassell education, 21, 24-25.

### Appendix 1

Overleaf are shown examples of print-based information and software resources developed specifically for the case study. These were used to support work on the Eurocollaborator Project and to assist with overcoming challenges that arose from the untypical nature of the work expected of teachers and pupils. The example of custom-built software tools shown overleaf was developed by the engineers for use by the schools in 'sizing' pupil's aircraft designs during the first year of the project, a challenge that was an untypical because the requirements of aerodynamics and lift exerted precise proportion on wings. The collaborative school teams were asked to develop designs for their planes and the software was given to them to help develop concept-planes that would be capable of flight. The software, which is a spreadsheet, allows dimensions to be entered and allows calculations programmed into the spreadsheet to be automated. Pupils were able to use this both to design an aircraft configuration and to check the performance of an aircraft configuration, such as the design range, cruise speed, cruise altitude, payload, takeoff distance, landing distance and wing configuration.

All six of the final consortium plane designs were developed using this software.

This software introduced new practices to the schools and its use represented a new precedent for the pupils and teachers. Some of the interfaces are shown overleaf to exemplify the approach to automating the sizing process.

SOURCE: Author

# Moving on with your concept idea: Sizing the aircraft

## Introduction

Before moving on with your concept idea you will need to make sure that your design could provide flight.

**Sizing** an aircraft means making sure that its proportions are realistic for the service expected of it. Sizing makes sure that certain **performance requirements** are successfully built in at this stage. For example, it would be no good developing a neat looking aircraft if the wings were the wrong size or shape to sustain flight or if the engines were not powerful enough to take off!

When aircraft designers start work they are normally given the performance requirements in the form of a **specification**. In your case you are left to decide the specification for yourself, although later you will be given a tighter brief to work to. Some requirements for a passenger aircraft are:

- Design Range** (greatest distance the aircraft is designed to fly)
- Cruising Speed, Altitude and Mach number** (speed and height when flying)
- Payload** (number of crew + passengers + cargo)
- Take-off Distance** (length of runway needed to get airborne)
- Landing Distance** (length of runway needed to land again)

A military aircraft will include some other performance requirements such as 'climb rates', 'sustained turn rates' and 'loiter times' because of the special duties it has to perform.

When designers cannot meet all the requirements they may sometimes change them slightly, or make compromises. For example if the range cannot be met, then the payload could be reduced to decrease the aircraft's weight. Or alternatively, the range stated in the specification could be changed to the best range that can be achieved by the design.

It is important to calculate the performance that your concept aircraft should be capable of. When you have done this you may find you will need to change some sizes for your aircraft for it to perform in the way you intend.

Before you begin the sizing process you should first decide on a specification. The following suggestions are intended to help you with this:

**Range:** Up to 15000 km (9400 miles). Long range is desirable but will require a large amount of fuel, which will increase the aircraft weight and size.

**Cruising speed:** Between 150 and 450 m/s (340 – 675 mph). The faster the better but near the speed of sound (above 260 m/s) the drag force will increase rapidly and more powerful engines will be needed. This means more fuel will be used.

**Cruise altitude:** Up to 12 km (39000 ft). Higher altitudes mean less drag because the air density is less, but the engine performance reduces with altitude.

**Payload:** As indicated by your market research but probably no more than 900 passengers. More passengers and cargo means more weight and fuel.

**Take-off distance:** From 500 to 3500 m. A short take-off distance is beneficial because it will allow the aircraft to operate from small airports with short runways. However, more thrust and a high lift wing is required for short take-off operations.

**Landing distance:** Between 500 to 2500 m. Again short landing performance is desirable but a high lift wing (complex and heavy) is needed for this.

## General Procedure

Having decided your specification, using the method described next will allow you to size your design. The mathematical formulae will allow you to calculate what your aircraft can achieve as well as indicate how you might need to change the design to perform in the way you intend. The results of your calculations, or **parameters**, will tell you if your specification can be achieved. Your parameters will be influenced by the shape, or **configuration**, of your chosen design as well as by the specification. You may find it necessary to change both the **specification** and the **configuration** to achieve a successful concept design

### What to Size:

#### Wing Loading (units: kg/m<sup>2</sup>)

The weight that each sq. meter of wing area must lift to keep the aircraft in the air.

#### Thrust Loading (no units)

The engine thrust as a fraction of the aircraft mass

#### Fuel Fraction (no units)

The fuel mass as a fraction of the aircraft take-off mass.

#### Mass Estimation (units: kg)

The overall aircraft mass is estimated based on the aircraft configuration

#### Wing Area (units: m<sup>2</sup>)

Knowing the mass and wing loading, the actual wing area can be found. This is important because for the first time it defines the size and hence the wingspan of your aircraft.

#### Engine Thrust Required (units: kg)

Again, knowing the mass and thrust loading, the engine thrust required can be calculated. From this suitable engines that give sufficient thrust can be selected.

### Stages in Sizing and Designing your Aircraft:

The flow diagram shown below shows the route that you must follow to find the six parameters – shown in green boxes. The starting points are the **configuration** and **specification** which are shown in yellow boxes. To begin with, you should also select engines that may be suitable for your design. Information about engines is needed by some stages of the method.

At each step certain information is required to complete the calculation. If exact values for this data are not known, then judgements are made to fill in gaps. Good engineering judgement is essential for the success of the aircraft, as well as the ability to calculate and predict performance. As the design progresses and more parameters are found, so more detailed calculations can be made. In this way, aircraft designers gradually build up a very detailed understanding of the design.

The flow diagram shows where it is sometimes necessary to recalculate some parameters in more detail. For example, the aerodynamic lift and drag is central to this method but it depends on many things including the weight of the aircraft. But to begin with we do not know what the weight is and realistic guesses have to be made. Later when we have found the weight, more accurate values for the lift and drag can be calculated. This process is known as an iteration.

There are other examples of iterations in this method:

1. For most aircraft, especially airliners, the wing is the fuel tank. When we have completed the calculations we need to check that the wings are big enough to carry all the fuel. We will have found both the fuel mass and wing area and from these it is possible to check whether there is enough volume in the wing to carry the fuel.



1  
2  
3  
4  
5  
6  
7  
8  
9  
10  
11  
12  
13  
14  
15  
16  
17  
18  
19  
20  
21  
22  
23  
24  
25  
26  
27  
28  
29  
30  
31  
32  
33  
34  
35  
36  
37  
38  
39  
40  
41  
42  
43  
44  
45  
46  
47  
48  
49  
50  
51  
52  
53  
54  
55  
56  
57  
58  
59  
60  
61  
62  
63  
64  
65  
66  
67  
68  
69  
70

**STEP 1**  
ENTER YOUR SPECIFICATION  
AND AEROPLANE SHAPE BELOW

Range	7000	km	4300	nm
Speed	2400	km/h	1600	nm/h
Altitude	10000	m	32800	ft
Wing Span	28.00	m	91.80	nm
Wing Area	50.00	m <sup>2</sup>	167.29	ft <sup>2</sup>

**STEP 2**  
RUN THE CALCULATIONS  
AND CHECK SHAPE IS OK

1. PRELIMINARY SIZING  
Look at the wing graph at the bottom of the sheet and pick a point for the wing loading and thrust loading. Enter them below:

WING LOADING	600	kg / m <sup>2</sup>
THRUST LOADING	0.3	no units

2. FUEL FRACTION  
This is the proportion of the take-off weight that is taken up by fuel. The remainder has been calculated from the data provided to you by the wing design expert (see below).

Fuel Fraction	0.28
---------------	------

3. WEIGHT DISTRIBUTION  
The maximum weight depends on the four things listed in the table below:  
1. One of them drives the **wing area**.  
2. To start the weight calculation, input the **grossed wing area** (not yet the value for Oswald efficiency and fuel weight).  
3. Input the **max fuel weight** and wing area to compute change. When the response, the iteration is done.  
4. Repeat steps 2 and 3 until the max fuel weight and wing area no longer change. When the response, the iteration is done.

Wing Area (m <sup>2</sup> )	50.00	1.72	50.00
Wing Span (m)	28.00	1.72	28.00
Wing Area (ft <sup>2</sup> )	1722.57	1.72	1722.57
Wing Span (ft)	91.80	1.72	91.80
Wing Area (m <sup>2</sup> )	1722.57	1.72	1722.57
Wing Area (ft <sup>2</sup> )	1722.57	1.72	1722.57
Wing Area (m <sup>2</sup> )	1722.57	1.72	1722.57
Wing Area (ft <sup>2</sup> )	1722.57	1.72	1722.57

**STEP 3**  
THIS IS A SUMMARY OF THE RESULTS  
FOR YOUR AEROPLANE

This method has calculated the engine size, wing area (gross) and weight (gross) to meet your specification. From these results extra information about the gross weight and engine can be found. These are listed below.

We have built in a gross default understanding of what the maximum thrust take-off is based on by an assumed. By this setting the design to show more weight for increase the engine size.

**1. ENGINE PERFORMANCE TABLE (L/D)**

Thrust	6000	kg
Wing Area	50.00	m <sup>2</sup>
Wing Span	28.00	m
Wing Area	1722.57	ft <sup>2</sup>
Wing Span	91.80	ft
Wing Area	1722.57	ft <sup>2</sup>
Wing Span	91.80	ft

**2. ENGINE REQUIREMENTS**

Thrust loading	0.3	no units
Wing Area	50.00	m <sup>2</sup>
Wing Span	28.00	m

**3. WEIGHT DISTRIBUTION TABLE**

Wing Loading	600	kg / m <sup>2</sup>
Wing Area	50.00	m <sup>2</sup>
Wing Span	28.00	m
Wing Area	1722.57	ft <sup>2</sup>
Wing Span	91.80	ft
Wing Area	1722.57	ft <sup>2</sup>
Wing Span	91.80	ft

The graph shows the shape of gross wings. The heavier colors are all the planes.

**4. CHECKS**  
Check 1: Are the wings big enough to carry the load?  
The indicator (which is the usable amount of span, chord and clean methods for air traffic) span, chord and clean methods for air traffic, the wings are not OK. Clean methods for air traffic, the wings are OK.

Wing area (m <sup>2</sup> )	50.00	1.72	50.00
Wing span (m)	28.00	1.72	28.00
Wing area (ft <sup>2</sup> )	1722.57	1.72	1722.57
Wing span (ft)	91.80	1.72	91.80
Wing area (m <sup>2</sup> )	1722.57	1.72	1722.57
Wing area (ft <sup>2</sup> )	1722.57	1.72	1722.57

Check 2: Are the engines clean in the sense of power, enough for take-off?

Wing area (m <sup>2</sup> )	50.00	1.72	50.00
Wing span (m)	28.00	1.72	28.00
Wing area (ft <sup>2</sup> )	1722.57	1.72	1722.57
Wing span (ft)	91.80	1.72	91.80
Wing area (m <sup>2</sup> )	1722.57	1.72	1722.57
Wing area (ft <sup>2</sup> )	1722.57	1.72	1722.57

**5. RANGE AND PERFORMANCE**  
This is calculated from the above information

Range (km)	7000
Speed (km/h)	2400
Altitude (m)	10000
Wing Area (m <sup>2</sup> )	50.00
Wing Span (m)	28.00
Wing Area (ft <sup>2</sup> )	1722.57
Wing Span (ft)	91.80
Wing Area (m <sup>2</sup> )	1722.57
Wing Area (ft <sup>2</sup> )	1722.57

**6. USE OF FUTURE TECHNOLOGY**  
The performance can be improved by assuming the use of advanced technology and engine development.

8.4.1. Hypersonic technology

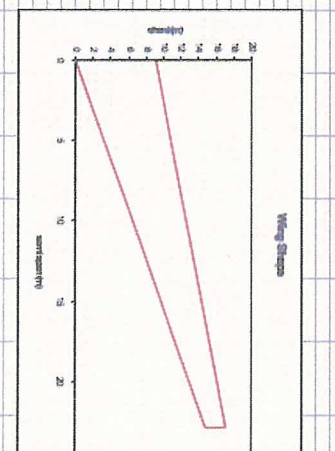



Appendix 2

Overleaf are shown examples of paper communications, circulated to all schools participating in the project, from BAE SYSTEMS (then British Aerospace). Paper-based communications of this kind continued to be used throughout the life of the project, alongside electronic communications such as email, the publication of computer files and videoconferencing.

The first example is of a letter sent to schools, shortly after teachers' participation at a conference in Warton introducing the case study. It was during this conference that teachers contributed a variety of ideas that were subsequently used to develop focussing themes I used to help with analysing the case study data.

The second example of paper communication is a milestone plan distributed by BAE SYSTEMS to the schools, used to introduce the idea of a two-year project to the schools in 1998.

It was unprecedented for the company to sponsor a project of this magnitude and time duration in the network schools, as well as for the schools to commit themselves to a two-year plan centred around a single project.

SOURCE: Author

Distribution: Lead Teachers Euro-collaborator Project

15 October 1998

Direct Telephone +44 (0)1772 85 2191  
Direct Facsimile +44 (0)1772 85 5298

**BRITISH AEROSPACE SCHOOLS NETWORK**  
**EURO-COLLABORATOR PROJECT**

Dear colleagues,

I hope that you enjoyed the launch of Euro-collaborator on the 15th September. You raised a lot of very useful points and the central planning team have been thinking a lot about them since then.

We were excited by the opportunities that you saw within the project at this stage. You have also been very frank and helpful about issues that could be barriers to success. We will obviously need to work hard at these to ensure the best chances for EuroCollaborator, which we feel will make a vital contribution to the understanding of young people over the next two years, as well as giving you and the pupils lots of fun and enjoyment.

I am repeating that it is our ambition you be able to include aspects of the project within your existing schemes of work by the New Year or before, not by replacing what you have already planned, but rather by enhancing and enriching this further so giving the pupils more opportunity. I will be sending you further information soon explaining how this can happen, but to help you now I am enclosing a clear statement of the need that we would like you and your pupils to consider at this stage, together with resources that should help you get started.

I am enclosing the following with this letter.

- 1) Feedback from the 15th September and views of the central planning team on how we can move forward on each point
- 2) A statement of the need we would like pupils to begin to consider in the earliest stages of Eurocollaborator (e.g any time from today). This will not be presented as a 'brief' yet, as some of you have requested. Instead we intend that the brief will be developed as a result of the work of pupils during the summer of 1999.
- 3) Resources for you and your pupils to enable them to begin to consider the need area we have defined. This will include case study material of the A3XX which we screened on the 15th and which so many of you requested for classroom use.

I think that you will agree that this material represents a major input for the need Eurocollaborator will address. We have introduced different materials for primary and secondary usage and further development of such material will be a recurring feature. The practice will be to send both kinds of materials to each school so that you are familiar with what might be taking place across phases. Please therefore do not be offended if material seems out of your phase; we simply think that you will probably be interested to see different approaches. Please also feel free to use material in stand alone case studies with any of your pupils, regardless of how you develop them for EuroCollaborator.

There is also a copy of the BAe produced video " Breaking the Curve " which many of enjoyed and thought would be useful to inspire the interest of your pupils.

If you are in a primary school you will soon be receiving specially developed materials' including software, from Mike Hirst, Head of International Education at Loughborough.

If you are in a secondary school, perhaps following a GCSE course with a narrower focus, you will need to think about what is special here. If you require a piece of assessed course-work as a result of using the materials, pupils should be advised that they can increase their chances of exam success by being clear about what the marking scheme expects.

Just to remind you of some features of Euro Collaborator., here are some of the things that you and your pupils will be doing over next 2 years :

- **Developing design proposals for a new passenger aircraft which may have similar capabilities to the A3XX described in the folder.**
- **The final product (s) will not be expected to fly but will be produced to high standards with many working parts.**
- **Work with Link Engineers from BAe.**
- **Communicate between schools and regions using video conferencing where appropriate.**
- **Working on similar or different components of the final aircraft which will fit together in the final stages.**
- **Use new software - DesignWave as a tool to assist in the final product.**
- **There will be an emphasis during the first year of pupils developing an understanding of the 4 main parts of an aircraft - The Fuselage, Wings, Engines / Power and Control Systems.**

Finally, I will be writing to you within the next three weeks with the next instalment of work for your pupils, to help them become increasingly involved with the EuroCollaborator project. This material will include at least one focussed task suitable for pupils across the KS2 to KS5 age range.

Good luck !!

Joe Roberts and the Team.



# Euro - Collaborator

## Year 1

Term 1

Term 2

Term 3

- training programme agreed
- project plan prepared

- as individual schools
- phase research through Sc/Ma/DT
- share Consortium materials
- classroom implementation

- as individual schools
- generate reports
- web site sharing
- **Project Day 1**

## Year 2

celebration event ↓

Term 1

Term 2

Term 3

- continue revisions
- production plan

- agree workshare in Consortium
- agree deadlines
- construct sub-assemblies

- as Consortium final assemblies
- construct one assembly per school
- **Project Day 2**

research...development/prototyping...production



Appendix 3

Overleaf is shown a computer concept model and working drawing that was developed by pupils and engineers for plane C5. Once agreed, these final versions were made available to each consortium of schools through management of the BAE SYSTEMS link-engineers. The approach here was to electronically define the agreed plane dimensions and interfaces for each consortium. The division of labour between the schools in each consortium, as well as the allocation of shared interfaces, was negotiated by the teams with a lead engineer. Once agreed, subsequent manufacturing was strictly regulated by the information defined in the computer models and drawings that were generated.

SOURCE: Author

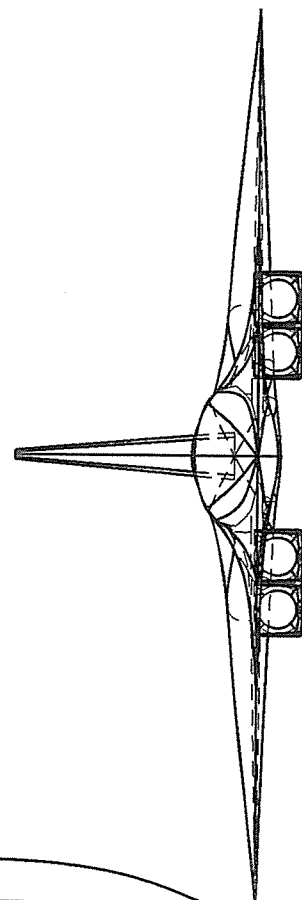
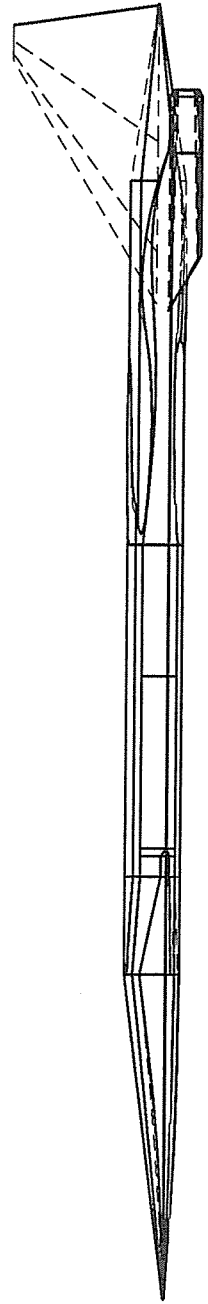
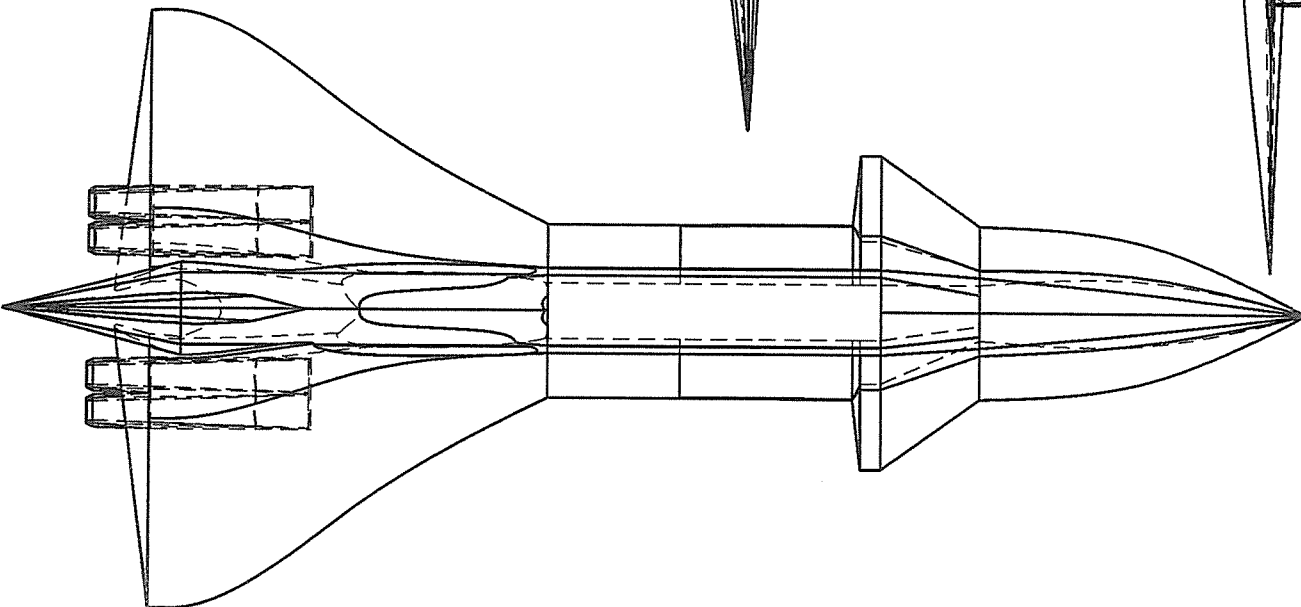

Fuselage Length: 80  
Fuselage Width: 5.5  
Overall Height: 14.87  
Wing Span: 37.44  
Gross Wing Area: 510  
Root Chord: 23.33  
Tip Chord:  
Wing Mean Chord:  
Aspect Ratio: 2.75  
1/4 chord Sweepback Angle: 45°

**GENERAL ASSEMBLY - FULL SCALE**

Consortium 5 - Tim Webb

Bristol MoD

UNCLASSIFIED

All measurements in metres

25th August 1999

Sheet 2b of

Appendix 4

I kept a diary of my impressions when visiting schools as I began to develop my thinking on transformation. An extract from my diary, the whole of which is available from the author, is provided below as an example:

*May 17 2000 (T. School, Buckinghamshire)*

*“It is strange entering very different schools and finding that they are engaged in the same work in this way. The pupils seem to be sharing something which they have an almost uncanny understanding of. Even when they are frustrated by some problem, they seem to share something else, which makes this OK, e.g. what they are sharing is not only the aircraft design (but a kind of collective understanding of the project). The teachers are on the sidelines. They have a different agenda. Last year they only saw problems. Now they fear losing (something of value) that they have established since the beginning of the project (maybe)....”*

*Some teacher’s expectations of others (colleagues) in other schools were frustrated. Colleagues were seen to let others down on this occasion, even though the result (e.g. a successful fit) may have been (achieved) ok. There is an issue here to with accountability, what seems fair, that the standards of others may vary greatly, of feeling let down by others, of the pupils maybe feeling let down when they have to depend on others who are outside the controls of the particular school concerned. What is acceptable in terms of quality is seen to vary too much, even though standards of accuracy were not specifically set at the commencement. One school made its component using old fashioned ‘Blue Peter’ techniques...wood, wallpaper etc. others used the CAD/CAM cycle to produce very accurate and ‘faithful’ components of an industry standard. This variability was a concern to the pupils and to some teachers. (the first trial assembly, it was felt, should have alerted them to the unacceptability of the standards and allowed time to put this right) It suggested letting the side down or creating problems for others which was unfair. Perhaps a different level of commitment was implied and people took this personally.”*

SOURCE: Author

Appendix 5

Although computer-definition provided sufficient information about the plane and its components for manufacturing to take place, the schools also arranged face-to-face meetings to discuss and run checks on progress with fitting the parts together.

The different colours of the plane sections in the pages overleaf identify the different manufacturing responsibilities of five different schools, a process similar to that used in defining manufacturing work-share for real-life civil and military aircraft manufacture (the actual production work-share being used for the Eurofighter at that time is shown inset, top right as an example). The photographic data of the particular Eurocollaborator plane shown, which was being built by consortium C5, is shown near completion in early 2000 and typifies the size and scale of the five other planes that were built in different regions of the country during the case study.

It was a new precedent for the pupils to collaborate in their designing and manufacture across school sites in this way, especially on such large-scale products.

SOURCE: Author



## Computers: transforming technologies in the classroom?

An industrial approach is adapted for the classroom here. On the right each colour represents a different manufacturing consortium of the European Union when building aircraft.

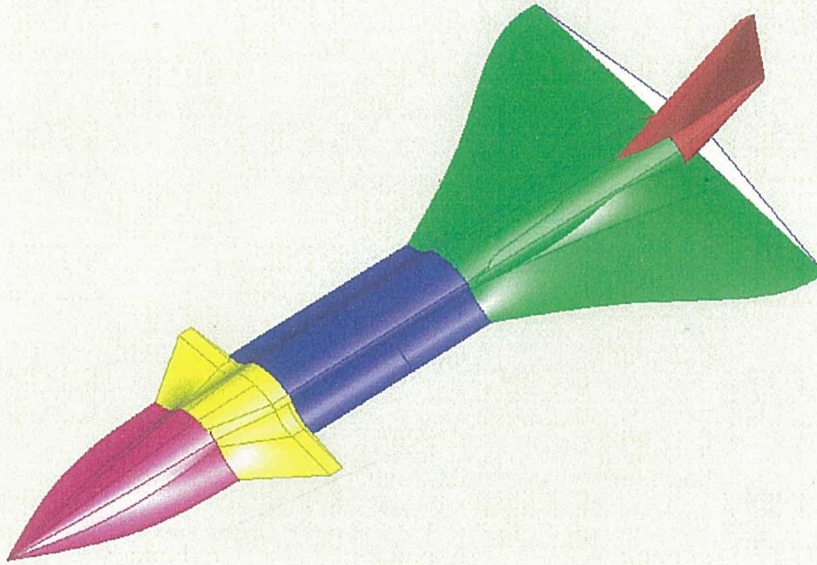
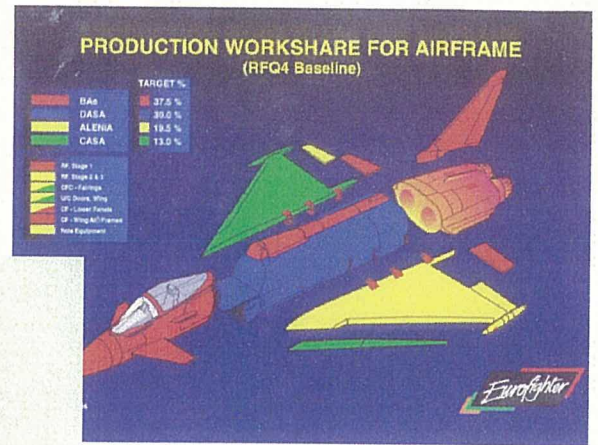

On the left, a scale model of a new passenger aircraft is being designed and assembled by pupils working from five separate school locations.

Each colour represents the 'work share' allocation of a different school.



In the scenes left and below, some of the pupils meet up to assemble the final model. The work of five schools is brought together in a single entity. Many problems still have to be resolved, despite the computers!



### Appendix 6

Certain difficulties with manufacturing techniques were experienced, for example with the complexity of intersections and understanding the mating of different components. In the example illustrated overleaf the problem was overcome by teams negotiating some assistance with work that could not be done in school. In this example the school was manufacturing a complex plane mid-section, and negotiated the use of specialist equipment at the University of Warwick Rapid Prototyping Department. This component was eventually generated from 7,000 layers of laminated paper, each individual layer being individually laser-generated from a computer model that the pupils had developed for part of their share of the plane.

The illustration shown is a simplified model of the process, also modelled by the pupils using special software, and used for communicating their ideas to pupils in other schools who were responsible for the adjacent parts of plane C5.

It was a new precedent for pupils to develop and communicate ideas in this way, one where electronic product definition was being used to ensure that mating of component parts by different pupil teams in different schools was achieved.

SOURCE: Author

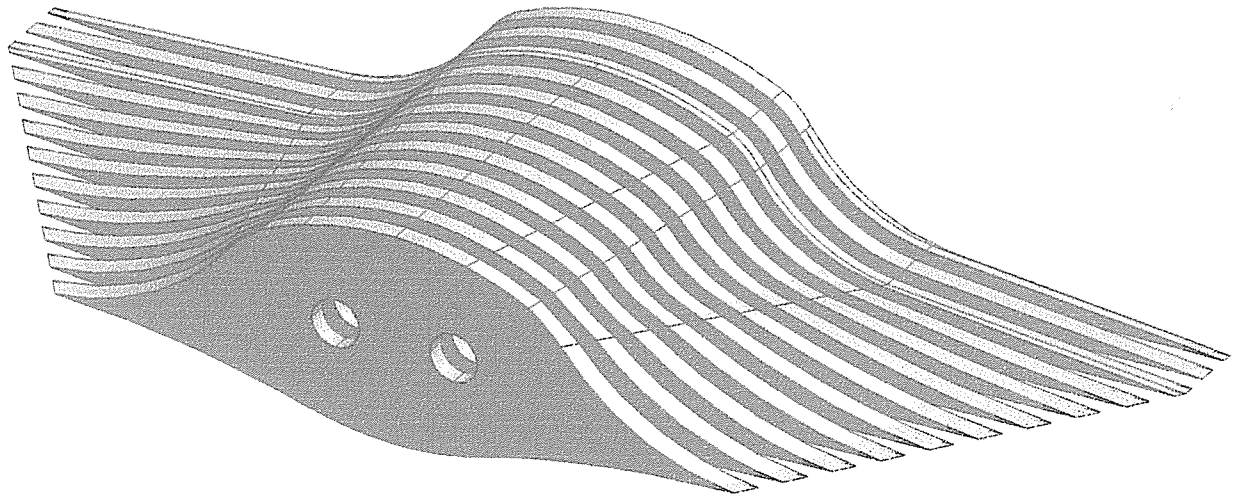

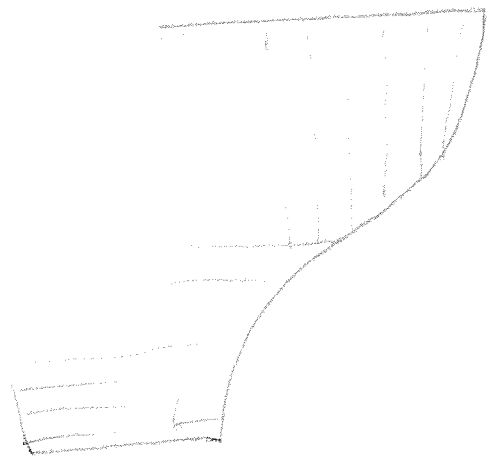
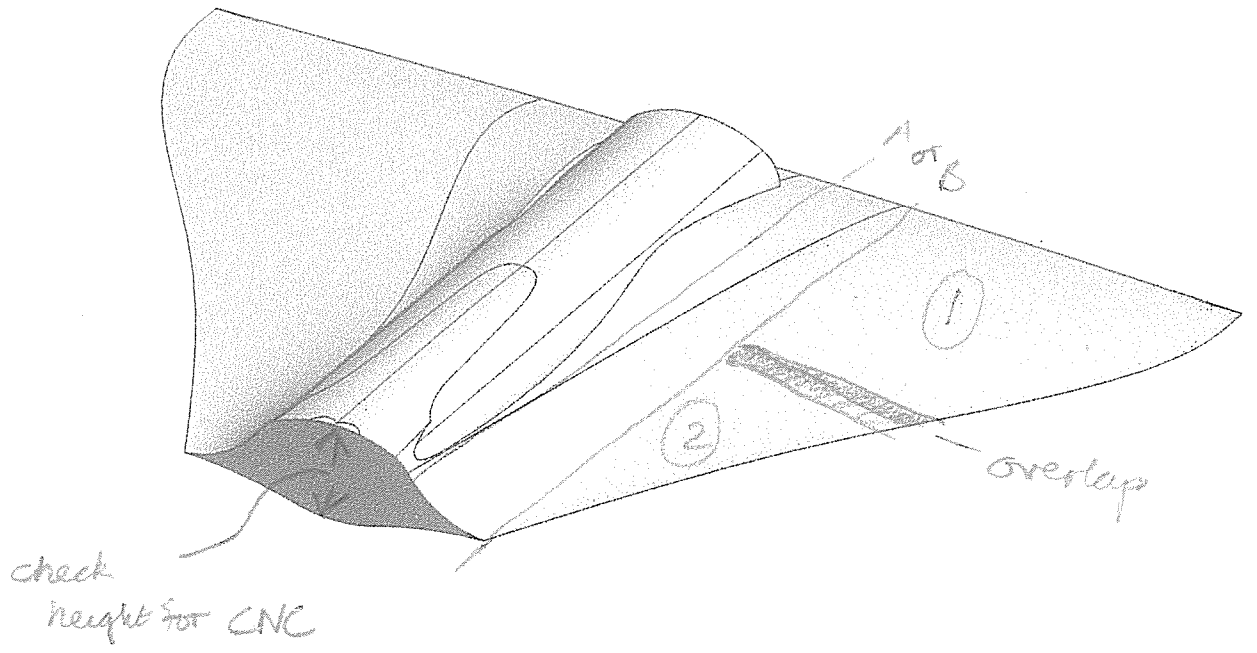

Appendix 7

Overleaf is shown the standard interview questions for teachers, engineers and pupils used during the case study. The data collected from these interviews was entered into a database, and is available from the author.

SOURCE: Author

## Questions for teachers

### Theme 1

- Influence of industry on this project.
- 1. How is it you are working with industry and using industrial approaches?
- 2. Can you show me some examples of what has happened here?
- 3. Do you think that working with industry is making the learning any better?
- 4. In what ways is it making the learning better?
- 5. Can you show me some examples which show that the pupils learned better?

### Theme 2

- Influence of ICT on pupils learning, e.g. video conferencing.
- 1. How are you using video conferencing, if at all, during this project?
- 2. Can you show me any examples of how it has been used by you/ pupils?
- 3. Do you think that video conferencing makes learning any better? (more rapid progress?)
- 4. In what ways can it make learning better?
- 5. Can you give me any examples of how video conferencing made learning better?

### Theme 3

- Working with teachers and pupils in other schools.
- 1. How have you used collaboration with pupils/ teachers in other schools as an approach to this project?
- 2. Can you show me any examples of collaborative working between your pupils and those in other schools?
- 3. Do you think that collaboration makes learning any better? (Were there any difficulties?)
- 4. In what ways do you think collaborating can make learning better?
- 5. Can you give me any examples of where collaborating made learning better?

### Theme 4

- Influence of CAD/CAM where available, e.g. ProDesktop
- 1. How have you used CAD and/or CAM (if at all) during this project?
- 2. Can you show me any examples of how pupils used CAD and/or CAM?
- 3. Do you think that using CAD and/or CAM makes learning any better?
- 4. In what ways do you think CAD/CAM can make learning better?
- 5. Can you give me an example of where CAD and/or CAM made learning any better?

### Theme 5

- How you used this project in the classroom.
- 1. How have you used the Eurocollaborator Project to teach design and technology?
- 2. Can you show me any examples of D&T teaching that resulted from participation in the Eurocollaborator project?
- 3. Do you think that the project has made D&T learning any better for your pupils?
- 4. In what ways do you think the project can make learning in D&T better?
- 5. Can you give me any examples of where the learning was better as a result of the project?

## Questions for pupils

### Theme 1

- The aircraft industry and your project.
- 1. How has this project helped you to learn about the aircraft industry?
- 2. Can you show me any examples of this?
- 3. Do you think that it is helping you to learn any better?
- 4. In what ways is it better?
- 5. Can you show me any examples?

### Theme 2

- Using computers, e.g. video conferencing.
- 1. Have you been able to use video conferencing for your work on Eurocollaborator?
- 2. Can you give an example of how you used it?
- 3. Did video conferencing help you to learn?
- 4. In what ways can it help you to learn?
- 5. Can you give me an example of how video conferencing can help you?

### Theme 3

- Working with people, e.g. other pupils or teachers, in other schools.
- 1. Have you worked with pupils or teachers in other schools during this project?
- 2. Can you show me any examples of what you did?
- 3. Do you think that working with pupils from other schools is helping you to learn better?
- 4. In what ways do you think collaborating can make learning better?
- 5. Can you give me any examples of where collaborating made learning better for you?

### Theme 4

- Computer Aided Design, e.g. ProDesktop
- 1. How have you used the computer during this project?
- 2. Can you show me any examples of how you used the computer?
- 3. Do you think that the computer is helping you to learn better?
- 4. In what ways can computers help you to learn better?
- 5. Can you give me some examples?

### Theme 5

- Different ways of working that you learned during this project.
- 1. Do you think Eurocollaborator lessons are different to other D&T lessons?
- 2. Can you show me any examples of how lessons are different?
- 3. Have you learned any better during Eurocollaborator lessons?
- 4. In what ways do you think Eurocollaborator lessons could help you to learn better?
- 5. Can you give me some examples?



## Questions for engineers

### Theme 1

- Your influence on this project.
- 1. How has this project helped you to work with teachers and pupils?
- 2. Can you give examples of particular ways in which you worked together as a direct result of this project?
- 3. Do you think that the project has helped pupils to learn any better, e.g. to learn particular things about the aircraft industry?
- 4. In what ways is this better than what you did before?
- 5. Can you give any examples which show that this work was better?

### Theme 2

- Influence of ICT on the work, including your ability to communicate with pupils and teachers, e.g. video conferencing.
- 1. Have you been able to use video conferencing to work with your school(s) on Eurocollaborator?
- 2. Can you give an example of how you used it?
- 3. Did video conferencing help you to help pupils to learn?
- 4. In what ways can it help pupils to learn?
- 5. Can you give me an example of how video conferencing helped you to work with your school/ pupil team/ link teacher?

### Theme 3

- Working with teams, including teachers other engineers and pupils in other schools.
- 1. Have you worked with pupils or teachers in schools, other than your own link school, during this project?
- 2. Can you show me any examples of how you worked with or took account of what was being done in other schools?
- 3. Do you think that encouraging collaborative working between groups of pupils in different schools, e.g. in your consortium, is helping pupils to learn better?
- 4. In what ways do you think collaborative working between schools can make learning better?
- 5. Can you give me any examples of where collaborating made learning better for pupils/ teachers in your link school?

### Theme 4

- Influence of CAD/CAM where available, e.g. ProDesktop
- 1. How have pupils in your link school used the computer during this project? (e.g. CAD and CAM, Spreadsheets, Databases etc.)
- 2. Can you describe particular examples of where they used the computer?
- 3. Do you think that using computers is helping them to learn better?
- 4. In what ways do you think computers can help pupils to learn better?
- 5. Can you describe any particular examples where your pupils learned better, or in more relevant ways, using the computer?

### Theme 5

- How this project worked in the classroom and how people responded to any new practices that were involved.
- 1. Do you think Eurocollaborator lessons provide a different experience to other D&T lessons?
- 2. Can you suggest ways in which the Eurocollaborator lessons are different?



3. Do you think pupils have learned any better during Eurocollaborator lessons?
4. In what ways do you think Eurocollaborator lessons could help your pupils to learn better?
5. Can you give me some examples of how the pupils experiences may have been better?

## Transformation and Pedagogy

### Appendix 8

Manufacturing and Electronic Product Definition explained.

Overleaf is a description derived from the Warwick Manufacturing Group's publication *THE TIME-TO-MARKET MACHINE* (1995), Computervision Corporation.

Warwick Manufacturing Group defined an approach to industrial manufacturing that had been adopted by BAE SYSTEMS for plane building at the time of the case study.

Extracts from Broughton, Manton and Puttick's (1990) statement are described here, explaining the emphasis on integrity and visibility of data and describing the concept of Electronic Product Definition (EPD). It was from this idea that the project team, working with BAE SYSTEMS, developed the industrial manufacturing perspectives of the case study (Eurocollaborator project):

'Physical mock-ups

..defining an aircraft engine: the traditional route...involved...physical mock-ups....which acted as master reference points for the design. Interconnecting service pipes, ducts and harnesses were laid in manually and clipped in place to complete the design. Work had to be conducted serially, since there was simply not room physically for all the personnel contributing to the design...to gain access to the relevant sections of the model simultaneously..... Mock-ups had to be constantly altered to accommodate engineering changes and special configurations

Integrity of Design Intent Demands Single Focus

Mock-ups were produced for final design approval, studies on serviceability and maintainability, airframe approval and certification. With so many different 'master' versions, maintaining complete integrity of design intent was virtually impossible.

Lack of Visibility and of Data Reuse

Further if a supplier, customer, or one of the in-house development team wants to check anything against the reference mock-ups, they would have to pay a visit to the relevant mock-up room. This is hardly conducive to the global extended enterprise that aircraft manufacturing has become, with the customer commonly thousands of miles away from the supplier.

Recreating Data Adds Risk

This is typical of traditional manufacturing processes, which EPD is to replace- the need to recreate or originate data to different stages of the development process, particularly at handover points between functions.

When the data represents highly complex components and subassemblies interacting through highly complex linkages, then the product becomes unforgiving of errors. The potential for loss of design integrity through recreating data that differs even marginally from the original mock-ups becomes all too clear....this potential for loss of design integrity led to a compelling argument for building a “virtual product” within its computer system from one integrated electronic database. This database would provide the “spine” running through the project that maintains continuity of data from the starting point of customer requirements to the finished point of a defined product. The aim is to eliminate mock-ups altogether and rely solely on a digital product model.’

Broughton, T. Manton, S. Puttick, J. (1995), *THE TIME-TO-MARKET MACHINE*, Computervision Corporation, case study 3, pp. 53.

Appendix 9

Schools participating in the Eurocollaborator project are identified in the table overleaf, some confidential information has been masked.

The 49 listed schools participated in the project over the two-year period. For each school, BAE SYSTEMS also appointed a link-employee engineer to support the project throughout this period.

It was a new precedent for the company to resource a single project on this scale, involving as it did the part-time release from the workplace of over 50 of its employees across a wide geographical area of England. The project engineers later received an internal award for innovation from the company, in recognition of their commitment to schools and education.

SOURCE: Author

## Euro Collaborator New Concept Aircraft 2000 and beyond

15 September Attendees List

	Name of School	Attendee	Link
1	All Hallows RC High , Penwortham, (TC)	Phil	Ken F
2	Archbishop Temple CE High, Fulwood. (TC)	Cha	Ripal
3	Arnold School ( Independent )	Mike	Dave
4	Aylesbury Grammar	Adri	Gillia
5	Beardwood High , Blackburn	Phil	Davie
6	Bish. Raw. CE High , Croston, Preston. (LC)	Nick	Emm
7	Broad oak CP, Primary	Kath	Adele
8	Broughton Primary	Davi	Brett
9	Calday Grange Grammar, Wirral, Merseyside	Bria	Kyle I
10	Carr Hill 11-18 High	Gary	TBA
11	Fleetwood's Charity Primary	Anne	Manji
12	Fulwood High School, Fulwood, Preston	Pete	Marc
13	Garstang High	Tim	David
14	Goosnargh Oliversons Primary	Mike	Gavir
15	Habergham High, Burnley	Mr. S	TBA
16	Hall Park Primary	Chris	Leah
17	Hodgson High (TC)	Tom	John
18	Holy Family Preston, Primary	Shar	Louis
19	Kirkham Grammar (Independent)	Stev	Nick I
20	Lancaster Girls Grammar (TC)	John	Dee C
21	Lancaster Royal Grammar (TC)	Philij	Jeff C
22	Leyland St Mary's High, Leyland,	Bob	Mick
23	Little Hoole Primary	Patri	Shan
24	Lytham St Annes High (TC)	Mike	Paul
25	Millfield High	Pete	Dunc
26	Montgomery High (LC)	Nico	Chris
27	Moor Park, Preston	Ray	Simon
28	New Longton Primary	Anne	Emm
29	Our Lady + St John RC High, Blackburn	Stev	Dunc
30	Plessington RC High,	John	Dan V
31	Priory High, Penwortham, Preston	Ian T	Denis
32	Shevington High (TC)	Davi	Steph
33	South Holderness	Andr	TBA
34	Southlands High, Chorley ( TC)	Keith	Stuar
35	St Aidans High (TC)	Lesle	Juliar
36	St Bede's RC High Lytham	Fran	Denn
37	St Cecilia's RC High , Longridge	Mela	Dami
38	St Matthews RC High	Bria	Antho
39	St Pauls Primary	Rach	Cathe
40	Strike Lane Primary	Lucy	Tony
41	St Wilfrid's C of E High (TC )	Keith	Kevin
42	The George Ward School	Tony	Steve
43	The Royal Grammar School High Wycombe	Colin	TBA
44	The Weald School, West Sussex	Julia	Steve
45	Tomlinscote School, Frimley, Surrey	Jim F	ter Arnal
46	Tulketh High School, Tulketh, Preston	Davie	Richa
47	Waterloo Primary	Davie	Debb
48	Westwood St Thomas, Salisbury, Wiltshire	John	Paul
49	Witton Park High, Blackburn	Philij	Russ

### Appendix 10

Overleaf is shown an example of interface modelling developed by pupils, and used by them to communicate the mating of different work-shared parts between different schools. This can also be thought of as a particular form of computer collaboration, one situated in the subject area of design & technology where three-dimensional products are being developed.

Some schools adopted more of a 'lead' or co-ordinating role in each consortium and were perhaps more active than other schools in the development of the final plane model. This extended to the behaviour of the leading pupil teams who would independently initiate communications with other pupils in the other consortium schools when this was needed.

Such dialogue on the electronic definition of each plane helped to ensure that mating components actually fitted together on final assembly, the success of two years of work depending on this. In the example shown overleaf, one school is proposing a means of accurately joining the different school components via a central square locating hole. In full-scale production, plane components from different EU countries are actually located in similar agreed fashion.

It was a new precedent for pupils to be encouraged to think in this way in design & technology, involving as it did the complex management of interfaces and design decisions on a consortium basis.

SOURCE: Author

New computer software (pro/DESKTOP) allowed pupils in different schools to communicate and develop their collaborative manufacturing requirements with each other to assure a fit. In this model the pupils developed a method of coding their separate parts, the two colours in the assembly represented the shapes that were to be mated together and belonged to pupils in two different schools of consortium C5.

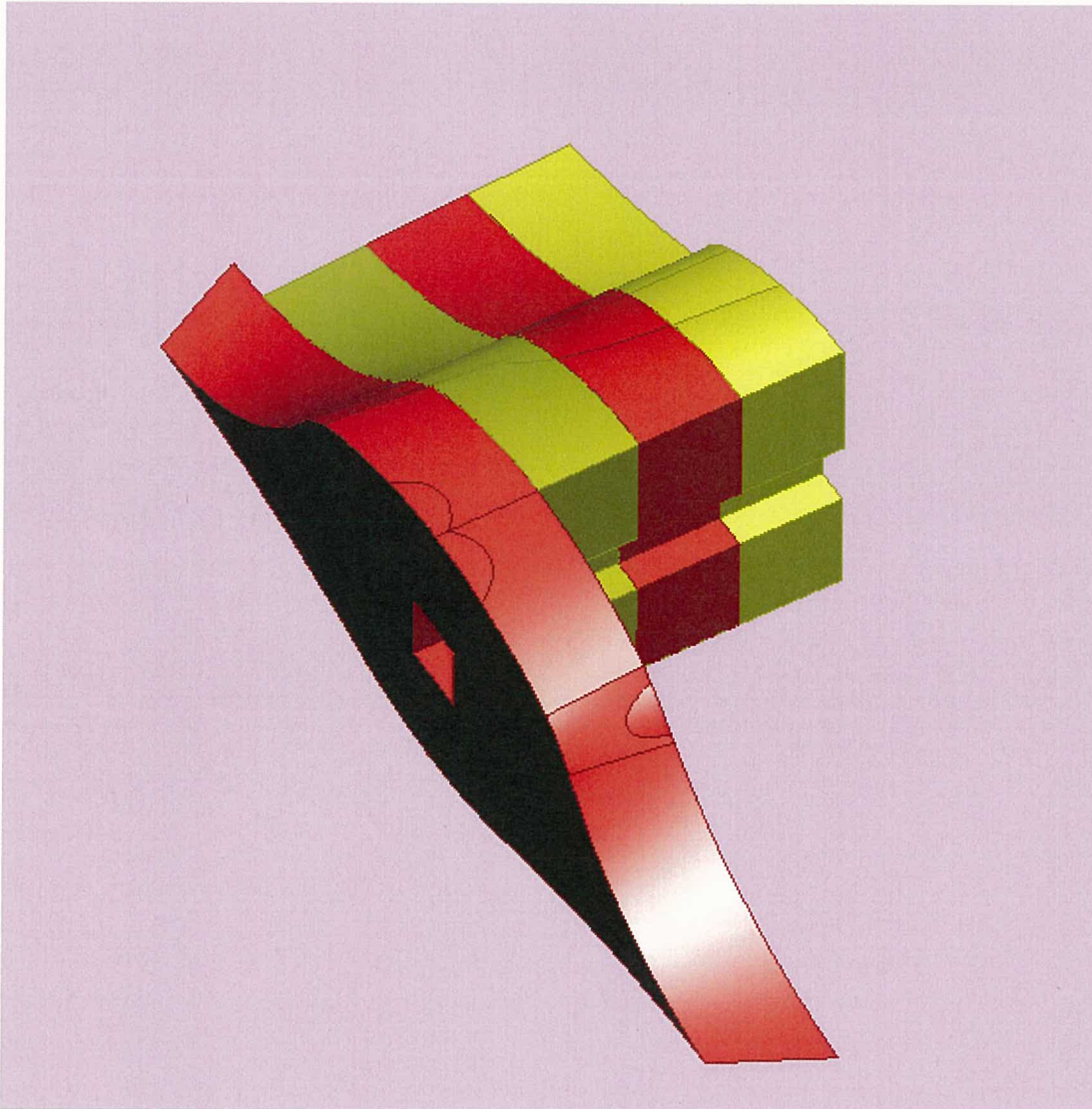



Appendix 11

Overleaf is shown an example from an NVivo Document Coding Report: 17th May 2001, node 1 of 33, (1.1) /issues that may influence pedagogy, passages 2 and 4 of 9: a teacher from one of the participating schools makes statements that are easy to attribute to the transformational categories but later contradictions reveal that care is needed in interpreting these.

SOURCE: Author

## DOCUMENT CODING REPORT

**Document:** 17th May,**Created:** 17/08/01 - 13:17:46**Modified:** 08/01/02 - 12:43:35**Description:**

17th May, Jim Rutherford and Rosemary Wailes, Tomlinscote School

**Nodes in Set:** All Tree NodesNode 1 of 33 (1 1) /issues that may influence pedagogy/what teachers can achiev in their

2

*Passage 1 of 9* Section 2.1, Para 80, 370 chars.

80: *videoconferencing, like all forms of technology, is going through its genesis... at the moment it is still at the staggering stage... which tends to damage its credibility... that would be a major reason. Secondly, I don't think there was any particular advantage in videoconferencing.... and the timetabling of events, getting people to be able to communicate, is very difficult.*

81:

---

*Passage 2 of 9* Section 2.5, Para 133, 313 chars.

133: *What was unfortunate was that, having had the first attempt at assembly... the people who had used what I would consider to be..umm... prototype methods to do their modelling didn't take on board anything from what they saw of what you had managed to achieve with Warwick and what we had managed to achieve on our own*

---

*Passage 3 of 9* Section 2.6, Para 141, 151 chars.

141: *...I mean eventually our two methods were identical, it was just you had many more layers....umm... I think that they felt that would be too time-consuming.*

---

*Passage 4 of 9* Section 3, Para 178, 253 chars.

178: *And in fairness, if you put aside the difficulties of the methods of construction, the fact that on the day of the RGS it actually looked pretty much as what we expected it to look like, there clearly had been enough collaboration to make it look right.*

---

*Passage 5 of 9* Section 3.1, Para 192, 384 chars.

192: *Yes, except that they weren't, that was the problem... if they had been....they were interdependent in terms of the overall project working ....but to be honest there is no great advantage to them working or not working... they either pleased or they didn't please me.....that*

Appendix 12

An explanation of ways pupils' data were analysed and considered in the research. A sample of fifty passages from the pupil data entered into NVivo, from node 27, is included. Such pupil data from the case study interviews was used to help inform the research ideas being developed on pedagogical precedence, for example that pedagogical transformation probably involved teaching significantly different to teachers' usual preceded approaches.

SOURCE: Author

## **The analysis of pupil data**

The interview data of pupils was analysed to check, at various stages in the examination of all interview data, that I could justify my argument for the case study being transformational. The analysis of pedagogical precedence conducted throughout this thesis is predicated on the idea that the case study did present new teaching precedents, such as in relation to industrial production through collaboration between individuals and schools, the sharing of work and in relation to new design & technology subject knowledge, as well as pedagogical wisdom with ICT.

I decided against the idea of attempting to analyse student data in direct pedagogical terms, or in the same ways that I was analysing data derived from interviews with teachers and engineers who were teaching the pupils. This decision related to my judgement that there needed to be a separation of my ideas in relation to teaching and to learning, for example that learners might not always learn as teachers expected or assumed. This allowed the learning of pupils, as actually described by them in relation to what they were doing in the case study, to be considered separately yet related to any transformations taking place. This strategy also allowed me to establish distance between the analysis of pedagogy and the positive framing of the interview questions, for example pupils might not agree that the case study was an improvement in their learning or in any significant ways different to how they were usually taught.

My approach to checking differences was to collect passages from pupil interview data, on an individual school basis, using NVivo, and to reflect carefully on what was being said in relation to the particular case study collaboration at that stage. This data was usually collected at the same time in each school, for example I would normally interview the teacher, engineer and some of the pupils on the same day on a particular school visit. This allowed me to consider what particular teachers and engineers were saying, on a school-by-school basis, in relation to their particular collaboration and their stage within it. The data was therefore connected in relation to the following:

- What did pupils say about their learning at this point in the case study?
- What were teacher(s) in that school saying about their teaching at this point?
- What did engineers say about their involvement in the case study at this point?

- Which of the six collaborative planes did all of this data refer to, and were there any local issues to consider?
- What were pupils, teachers and engineers saying in the other work-sharing schools in this collaboration?
- What part of the plane were the pupils manufacturing and were there any specific issues in relation to this part, or in accommodating it with the work of others?

On the basis of the above reflection I could then consider how, if at all, did this data and these comparisons suggest that the case study was transformational.

A sample of fifty passages, taken from NVivo pupils interview data, is also provided here as an example of the material that I extracted and analysed. This particular material was obtained on 16<sup>th</sup> May 2000, and related to aircraft C5. The particular part the pupils were building (red section illustrated in appendix 5, which identifies schools in relation to C5 parts) was the tail-plane.

*What pupil's said about 'learning better', node 2.7.*

Document '16May 2000, Aylesbury Grammar pupils', 50 passages, 3315 characters.

Section 1, Paragraph 19, 40 characters.

we had a close focus and something to do

Section 1, Paragraph 23, 50 characters.

it just got everyone involved and talking about it

Section 1, Paragraph 33, 56 characters.

we were allowed to ask questions and to get answers back

Section 1, Paragraph 40, 91 characters.

It gave us a different viewpoint and sort of like the profession's perspective of our ideas

Section 1, Paragraph 45, 46 characters.

they gave us new areas to look at and consider

Section 1, Paragraph 52, 34 characters.

we did a videoconference with them

Section 2, Paragraph 90, 143 characters.

It's a team and everyone's got like their own points and also their own areas of knowledge. So if you can put them all together. it works well.

Section 2, Paragraph 94, 98 characters.

you are actively involved rather than someone just speaking at you. So you tend to take it in more

Section 3, Paragraph 116, 39 characters.

it meant we could change things quickly

Section 3, Paragraph 120, 114 characters.

**It would give a new image of the plane...rather than having to draw them out all again which is very time consuming.**

**Section 4.1, Paragraph 139, 61 characters.**

**it made it a lot more interesting because we were in control.**

**Section 4.1, Paragraph 143, 84 characters.**

**we sort of organised what was going to happen.....and pulled the whole thing together.**

**Section 4.1, Paragraph 147, 61 characters.**

**we were responsible for what happened...it helped with teamwork**

**Section 4.1, Paragraph 151, 74 characters.**

**it was our responsibility to get everything done on time for the deadlines**

**Section 4.2, Paragraph 155, 66 characters.**

**with it being our project it was actually reflected directly on us**

**Section 5.1, Paragraph 167, 45 characters.**

**closer in terms of the engineering side of it**

**Section 5.1, Paragraph 179, 41 characters.**

**the more you learn, the easier it becomes**

**Section 5.2, Paragraph 183, 35 characters.**

**that always helps..I enjoy teamwork**

**Section 5.3, Paragraph 195, 98 characters.**

**the brainstorming, getting down our initial real basic ideas about how we should start and move on**

**Section 6.1, Paragraph 213, 37 characters.**

**we could just get on with asking them**

**Section 6.1, Paragraph 213, 64 characters.**

**so any gaps in our knowledge we could learn quickly....and easily.**

**Section 8.3, Paragraphs 291-293, 171 characters.**

**So the computer helped you to move the ideas forward...**

**Yes, without having to put too much effort in...and scrapping ideas ...and we could always save bits on the way as well.**

**Section 8.3, Paragraph 300, 44 characters.**

**we've used it develop our ideas very soundly**

**Section 9, Paragraph 308, 98 characters.**

**We had planned goals, things we had to achieve, it was self-motivating rather than teacher-driven.**

**Section 9, Paragraph 312, 26 characters.**

**we could have fun doing it**

**Section 9.1, Paragraph 318, 74 characters.**

**I've learned more on the individuals.....how they react to certain pressures**

**Section 10, Paragraph 341, 29 characters.**

**its helped me to actually see**

**Section 10.3, Paragraph 362, 46 characters.**

**it means we can actually generalise a lot more**

**Section 10.3, Paragraph 362, 62 characters.**

**be more specific on the actual area of work we were working on**

**Section 10.3, Paragraph 362, 56 characters.**

**a lot of research has to go into that individual piece.**

**Section 10.3, Paragraph 366, 28 characters.**

**it gives a real good insight**

**Section 11.2, Paragraph 387, 77 characters.**

**actual dimensions of the mating surfaces, so we worked to that specification.**

**Section 11.3.1, Paragraph 395, 59 characters.**



so to me its actually diversifying my....I like it, its good.

Section 11.6, Paragraph 411, 94 characters.

the computers actually enabled us to contact each other quite quickly. ...almost instantaneously

Section 11.6, Paragraph 411, 90 characters.

at one point I think there was actually communication there and back within the hour or so

Section 12.1, Paragraph 432, 42 characters.

All of the responsibilities were delegated

Section 12.1, Paragraph 436, 65 characters.

I've had very limited experience of working in school with teams

Section 12.1, Paragraph 436, 65 characters.

actual engineering processes where there is an allocation of work

Section 12.1, Paragraph 436, 47 characters.

a large amount of communications between groups

Section 13, Paragraph 441, 106 characters.

we've only really scratched on the surface of ProDESKTOP, we haven't really used it to its full capability

Section 13, Paragraph 441, 36 characters.

it can potentially be quite powerful

Section 13.2, Paragraph 453, 92 characters.

we had to really work to it by hand...to actually ensure that the mating surfaces were correct

Section 13.3, Paragraph 462, 71 characters.

the computer could do everything but there was quite a bit of hand work

Section 13.3, Paragraph 466, 78 characters.

That was the essential linking piece between all the groups. That was crucial

**Section 13.6, Paragraph 487, 93 characters.**

**Yes, its very unusual to actually work in that way...but not so unusual in real life I imagine**

**Section 13.6, Paragraph 487, 53 characters.**

**all that calibrating I imagine it is a learning curve**

**Section 13.8, Paragraph 499, 24 characters.**

**that was quite pleasing.**

**Section 14.1, Paragraph 529, 63 characters.**

**They were able to communicate with the other schools quite well**

**Section 14.1, Paragraph 537, 29 characters.**

**I actually enjoyed doing it..**

**Section 14.1, Paragraph 545, 120 characters.**

**The one thing I have learned is to be engaged I mean.....normally I am not that good at it.....but since this I have actually**

Appendix 13

Overleaf is a description, developed using ideas from Ritz, J.M., Hadley, F. H., Bonebrake J. (1990), explaining how computers belong to a new higher level in a manufacturing evolutionary cycle. There was a difficulty in schools representing this idea.

There had been an evolutionary shift in the stages of production systems during the recent history of the U.S.A.. Ritz et al. (1990) described major observable stages to 'include **household, handicraft, factory, automated and cybernetic systems.**'

In this classification of manufacturing systems, computers are described as belong to a new higher level in manufacturing evolutionary cycle:

A classification of manufacturing evolution

Stage	Main characteristics of production system
Household	Materials, structures or goods are produced within the confines of the home and are consumed by the immediate family. In these cases people do not have money to purchase such essentials on the market and do not have extra goods from their productive efforts to use for barter or sale.
Handicraft	Found in societies which have improved their technological systems and have established a mercantile or trade system. Products are produced in the home or shop, but unlike the household production system surplus products to family are sold or traded.
Factory	Here craftsmen are gathered under one roof to produce their wares, with work being centralised. More products could be produced, a centralised system for procuring raw materials, centralising trained for production jobs, a centralised network for productive distribution could be established, together with a system for managing efficient and profitable production. While factory systems can produce more products for more people there are drawbacks, including the quality of life for workers working in the centralised workplace. The first factories worked on the principle of <i>customised production</i> where a person or team of people would craft a particular product. Alternatively they could use <i>batch-production</i> , where the person or team would craft a number of products or parts. Sometimes these parts would be further assembled at a later

	<p>time.</p> <p>A third method of production known as <i>continuous production</i>, is associated with the assembly-line and Henry Ford's methods. It relies on mass consumption of goods by consumers and a need must exist before the owners of factories will switch to the continuous production of a certain product, example being automobiles, beverages and cosmetics.</p> <p>These methods reduce the cost of products to the consumer because of volume of production, while producers can reduce costs by buying raw materials in volume and making processes more efficient.</p>
Automated	<p>This is a more advanced form of factory production where much of the work is done by automated machines and controls and much human manual skill has been displaced. Automated factories use machines that load themselves, process the product, test themselves, for quality and send the product to the workspaces for further processing. Microprocessors and computers operate and control the production in automated factories. Typical products include glass, chemicals, distilled beverages and others made on a continuous flow by self-operating machines. Parts of whole assembly lines are commonly automated, with robots replacing humans in certain situations. Computerised Numerical Control (CNC) was being used where more accurate and repetitive machining of parts is required.</p>
Cybernetic	<p>The most advanced system of production where all aspects are controlled by computers, including the design of products to be produced, control of machines that produce the products, monitoring of machines for accuracy, as well as regulation of machines and control of the total production system.</p>

Ritz, J.M., Hadley, F. H. , Bonebrake J. (1990), *Exploring Production Systems: Processing, Construction, Manufacturing*, Davis Publications Inc. Worcester, Massachusetts, U.S.A. , ISBN 0-87192-205-3, pp. 11.

## Transformation and Pedagogy

### Appendix 14

Overleaf is included the MRES Ethical implications of proposed research declaration for this research into transformation and pedagogy.

# University of Bath Department of Education

## MRES: ETHICAL IMPLICATIONS OF PROPOSED SRAP / LRAP/ DISSERTATION (DEMREF)

To be completed by the student and approved by the SRAP/LRAP/Dissertation supervisor and the DoS before the research takes place. This form can only be approved if the general *MRes ethics form* (consisting of 4 pages) is attached.

<b>Name</b>	Anthony Ros Booth		
<i>Please tick box as appropriate</i>	<input type="checkbox"/> <b>SRAP</b>	<input type="checkbox"/> <b>LRAP</b>	<input type="checkbox"/> <b>Dissertation</b>
<b>Title</b>	Transformation and pedagogy		
<b>Ethical Considerations</b>			
<p><i>All research carried out within the Department of Education by its staff and students is informed by the University's own Code of Ethics (<a href="http://www.bath.ac.uk/vc/policy/ethics.htm">www.bath.ac.uk/vc/policy/ethics.htm</a>) and by the British Educational Research Association (BERA) guidelines (<a href="http://www.bera.ac.uk/publications/guides.php">www.bera.ac.uk/publications/guides.php</a>).</i></p> <p><i>Please summarise the ethical issues which will need to be managed during your research in the MRes ethics form (4 pages), and then check the boxes as appropriate in the list below. Add to your MRes Ethics form if appropriate.</i></p>			
	<b>Yes</b>	<b>No</b>	
1. Does the study involve participants who are particularly vulnerable or unable to give informed consent? (eg children, people with learning disabilities)		✓	
2. Will the study require the co-operation of a gatekeeper for initial access to the groups or individuals to be recruited? (eg students at school, members of self-help group, residents of a nursing home)		✓	
3. Will it be necessary for participants to take part in the study without their knowledge and consent at the time? (eg covert observation of people in non-public places)		✓	
4. Will the study involve discussion of sensitive topics? (eg sexual activity, drug use)		✓	
5. Will the study involve prolonged or repetitive testing?		✓	
6. Will financial inducements (or other reasonable expenses and compensation for time) be offered to participants?		✓	
7. Will the study involve the recording of digital images of people?	✓ (non-essential)		
8. Will the study involve the use of methods and / or <i>ethics</i> appropriate to particular cultural contexts (eg, protocols appropriate to research with particular populations)		✓	
9. Could the study induce psychological stress or anxiety or cause harm or negative consequences beyond the risks encountered in normal life?		✓	
10. Will there be any effect on or damage to the environment?		✓	
11. Are any ethical issues likely to arise from the dissemination of results?		✓	
12. Will the study involve obtaining or processing personal data relating to living individuals, (eg involve recording interviews with subjects even if the findings will subsequently be made anonymous)? <small>(NB: If 'yes', you will need to ensure that the provisions of the Data Protection Act are complied with. In particular you will need to seek advice to ensure that the subjects provide sufficient consent and that the personal data will be properly stored, for an appropriate period of time). Information is available from the University Data Protection Website and <a href="mailto:dataprotection-queries@bath.ac.uk">dataprotection-queries@bath.ac.uk</a></small>		✓	

I confirm that this describes the ethical issues which will need to be managed during my research.

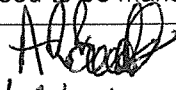
<b>Student</b> Anthony Ros Booth	<b>Signature:</b> 	<b>Date:</b> 16/02/09
-------------------------------------	--	--------------------------

# University of Bath Department of Education

## MRES: ETHICAL IMPLICATIONS OF PROPOSED SRAP / LRAP/ DISSERTATION (DEMREF)

To be completed by the student and approved by the SRAP/LRAP/Dissertation supervisor and the DoS before the research takes place. This form can only be approved if the general *MRes ethics form* (consisting of 4 pages) is attached.

<b>Supervising Member of Staff</b>	 <b>Signature:</b> <b>Date: 3/2/2009</b>
<b>Director of Studies</b>	<b>Signature:</b> <b>Date:</b>

State: 1. May 2008