

University of Bath



PHD

Benzene alkylation with ethane into ethylbenzene over Pt-containing zeolite bifunctional catalysts

Wong, Ivy

Award date:
2009

Awarding institution:
University of Bath

[Link to publication](#)

General rights

Copyright and moral rights for the publications made accessible in the public portal are retained by the authors and/or other copyright owners and it is a condition of accessing publications that users recognise and abide by the legal requirements associated with these rights.

- Users may download and print one copy of any publication from the public portal for the purpose of private study or research.
- You may not further distribute the material or use it for any profit-making activity or commercial gain
- You may freely distribute the URL identifying the publication in the public portal ?

Take down policy

If you believe that this document breaches copyright please contact us providing details, and we will remove access to the work immediately and investigate your claim.

Benzene alkylation with ethane into ethylbenzene over Pt-containing zeolite bifunctional catalysts

Kae Shin Wong

A thesis submitted for the degree of Doctor of Philosophy

University of Bath

Department of Chemical Engineering

March 2009

COPYRIGHT

Attention is drawn to the fact that copyright of this thesis rests with its author. This copy of the thesis has been supplied on condition that anyone who consults it is understood to recognise that its copyright rests with its author and that no quotation from the thesis and no information derived from it may be published without the prior written consent of the author.

This thesis may be made available for consultation within the University Library and may be photocopied or lent to other libraries for the purpose of consultation.

Acknowledgements

This PhD thesis is the result of three years of work during which I have been supported and accompanied by many people. It is now my great pleasure to take this opportunity to thank them.

I would like to gratefully acknowledge the enthusiastic supervision of Dr. Dmitry Lukyanov and Tanya Vazhnova. This thesis would not have been possible without their kind support, the trenchant critiques, the probing questions, and the remarkable patience. Additionally, I am truly thankful to my second supervisor, Dr. Sean Rigby, for his full support in all aspects. Also, thanks go to Dr. Paul Millington for analysis of Pt dispersion in the catalysts used in this work.

I would also like to thank the staff and postgraduates at the Department of Chemical Engineering, University of Bath for their support throughout my studies in Bath. In particular, I am grateful to Sally Barker, Mervyn Newnes, and Robert Brain. Special thanks go to the financial sponsor of this project, Engineering and Physical Sciences Research Council (EPSRC) of the UK.

My parents, Ah Fook Wong and Marry Teo, and my brother and sister-in-law, Kae Perng and Li Hua, have been a constant source of emotional and financial support during my years of studies. I thank them for their perpetual love which helped me in regaining faith during the frustrating moments of my PhD research. Last but not least, I am grateful to all my friends for being the surrogate family during the many years of my stay in Bath.

Abstract

Ethylbenzene (EB) is currently produced *via* acid catalyzed benzene alkylation with ethene, which is a product of highly endothermic and energy intensive processes. The new reaction, which uses ethane for benzene alkylation, instead of ethene, would eliminate the ethene production step, thus, leading to the commercial and environmental benefits in the EB manufacturing. Benzene alkylation with ethane into EB can be achieved using bifunctional zeolite catalysts, which combine ethane dehydrogenation into ethene over metal sites with benzene alkylation by ethene over Brønsted acid sites.

The benzene alkylation with ethane into EB over Pt-containing (1 wt.%) ZSM-5 bifunctional catalyst was investigated at six different temperatures (290, 330, 370, 410, 450 and 490°C). The optimum reaction temperature as well as the effect of temperature on the catalyst performance and reaction pathways were established. Excellent catalyst performance was obtained at 370°C, at which very stable catalyst operation (46 h on stream) is observed and the EB selectivity above 90 mol.% is achieved at benzene conversion of 12.5%, which is very close to the maximum equilibrium conversion of benzene into EB at this temperature (13.6%). The obtained results have shown that the temperature has different effects on the rates of the different reaction steps, leading to the different product distributions at different temperatures. It is established that similar reaction pathways operate in the temperature range of 290-490°C and that the EB formation proceeds *via* two consecutive reaction steps: (i) ethane dehydrogenation into ethene and hydrogen and (ii) benzene alkylation with ethene. The formations of all by-products have been discussed and a detailed reaction scheme of benzene alkylation with ethane into EB has been proposed. The optimisation of the catalyst compositions was carried out at 370°C with ZSM-5 catalysts containing 0.01, 0.025, 0.1, 0.5 and 1 wt.% of Pt. The PtH-ZSM-5 catalyst with 0.1 wt.% of Pt was found to be the most promising catalyst as it improves the EB selectivity from 90 to 94 mol.% at 12.5% of benzene conversion. With relatively low Pt loading, this catalyst demonstrates very stable performance during 48 hours on stream.

Contents

Acknowledgements	2
Abstract	3
Contents	4
List of Figures	7
List of Tables	11
Abbreviation	12
Nomenclature	14
Chapter 1 Introduction	16
Chapter 2 Literature Review	22
2.1. Commercial ethylbenzene production.....	23
2.2. Benzene alkylation with light alkanes.....	25
2.2.1. Conversion of light alkanes into light alkenes and aromatics hydrocarbon.....	29
2.2.1.1. The primary transformation of light alkane	31
2.2.1.2. The secondary transformation of alkane	36
2.2.2. Benzene alkylation with light alkanes: primary and secondary reaction steps	40
2.2.2.1. The primary steps of benzene alkylation reaction.....	40
2.2.2.2. The secondary steps of benzene alkylation reaction.....	42
2.3. Catalysts for benzene alkylation with light alkanes	48
2.3.1. Bifunctional catalysts: the support.....	50
2.3.1.1. Zeolites.....	50
2.3.2. Bifunctional catalysts: the metal	55
2.3.3. Pt supported bifunctional catalyst	58
2.3.3.1. PtH-ZSM-5.....	59
2.3.3.2. Pt/Al ₂ O ₃ and Pt/SiO ₂	61
2.3.4. Catalyst preparation methods.....	62
2.3.4.1. Impregnation	62
2.3.4.2. Ion-exchange	63
2.3.5. Catalyst pre-treatment procedures.....	64
2.3.5.1. Drying and calcination	65
2.3.5.2. Hydrogen reduction.....	66
2.3.5.3. The effects of pre-treatment procedures	67
Chapter 3 Experimental Materials and Methodology	72
3.1. Catalyst preparation	73
3.1.1. Calcination	73
3.1.2. Impregnation	73
3.2. Kinetic Studies	74
3.2.1 Catalytic rig.....	74
3.2.1.1. Gases	74
3.2.1.2. Distribution system	75

3.2.1.3. Saturator	80
3.2.1.4. Reactor and by-pass	80
3.2.1.5. Gas chromatograph	81
3.2.1.6. Temperature Controller	81
3.2.2. Operating procedures	82
3.2.2.1. Fraction preparation	82
3.2.2.2. Charging the reactor	82
3.2.2.3. Installing the reactor	83
3.2.2.4. Pre-treatment of the catalyst	83
3.2.2.5. Catalytic experiments	84
3.2.3. Analysis of products	85
3.2.3.1. Calibrations	85
3.2.3.2. Chromatograms and peak area table	87
3.2.3.3. Calculations	88
3.2.3.4. Error analyses	95
3.3. Catalyst Characterisation	98
3.3.1. CO chemisorption	98

Chapter 4 The Consideration of Thermodynamic Equilibrium and Selection of Reaction Conditions 100

Chapter 5 Effect of Reaction Temperature on Benzene Alkylation with Ethane into Ethylbenzene 110

5.1. Preliminary investigation of benzene alkylation with ethane	111
5.1.1. Establishment of the reaction steady state	112
5.1.2. Performance of the catalyst at 370°C	118
5.2. Selection of the reaction temperature range	122
5.2.1. Catalyst performance at low (290°C), moderate (370°C) and high (490°C) temperatures	123
5.2.2. Product distribution and reaction pathways at moderate (370°C) and high (490°C) temperatures	134
5.3. The optimum reaction temperature	142
5.3.1. The effect of temperature on catalyst performance	143
5.3.2. The effect of temperature on product distribution	154

Chapter 6 Reaction Pathways..... 164

6.1. Reaction steps at low contact time	165
6.2. Reaction steps at high contact time	168

Chapter 7 Effect of Catalyst Compositions on Benzene Alkylation with Ethane into EB 176

7.1. Preliminary analysis of PtH-ZSM-5(80) and PtH-ZSM-5(72)	178
7.2. Effect of metal species on benzene alkylation with ethane into EB	180
7.2.1. Effect of metal species on catalyst activity	180
7.2.2. Effect of metal species on product distribution	184
7.3. The selection of promising catalyst	190

7.3.1. The effect of Pt loading on catalyst performance	191
7.3.2. The effect of Pt loading on product distribution	203
Chapter 8 Conclusions and Future Work	210
8.1. Conclusions	211
8.2. Future work	213
References.....	216
Appendix 1: Thermodynamic Calculations	224
A1.1. Benzene alkylation with ethane.....	224
A1.2. Ethane dehydrogenation reaction	225
Appendix 2: List of Publications.....	227
A2.1. Effect of reaction temperature on benzene alkylation with ethane into ethylbenzene over PtH-ZSM-5 bifunctional catalyst.....	228
A2.2. Alkylation of benzene with ethane into ethylbenzene over PtH-ZSM-5 bifunctional catalyst at low temperatures.....	230
A2.3. Alkylation of benzene with ethane into ethylbenzene over PtH-ZSM-5 bifunctional catalyst at low and high reaction temperatures.....	231
A2.4. Selective and Stable Alkylation of Benzene with Ethane into Ethylbenzene over PtH-ZSM-5 Bifunctional Catalyst	233
Appendix 3: Experimental data of benzene alkylation with ethane.....	234
A3.1. Concentrations (mol.%) of products produced over 1PtH-ZSM-5(80) catalyst at 290°C.....	234
A3.2. Concentrations (mol.%) of products produced over 1PtH-ZSM-5(80) catalyst at 330°C.....	238
A3.3. Concentrations (mol.%) of products produced over 1PtH-ZSM-5(80) catalyst at 370°C.....	242
A3.4. Concentrations (mol.%) of products produced over 1PtH-ZSM-5(80) catalyst at 410°C.....	247
A3.5. Concentrations (mol.%) of products produced over 1PtH-ZSM-5(80) catalyst at 450°C.....	251
A3.6. Concentrations (mol.%) of products produced over 1PtH-ZSM-5(80) catalyst at 490°C.....	257
A3.7. Concentrations (mol.%) of products produced over H-ZSM-5(72) catalyst at 370°C.....	260
A3.8. Concentrations (mol.%) of products produced over 0.01PtH-ZSM-5(72) catalyst at 370°C.....	262
A3.9. Concentrations (mol.%) of products produced over 0.025PtH-ZSM-5(72) catalyst at 370°C.....	266
A3.10. Concentrations (mol.%) of products produced over 0.1PtH-ZSM-5(72) catalyst at 370°C.....	270
A3.11. Concentrations (mol.%) of products produced over 0.5PtH-ZSM-5(72) catalyst at 370°C.....	274
A3.12. Concentrations (mol.%) of products produced over 1PtH-ZSM-5(72) catalyst at 370°C.....	278

List of Figures

Figure 2.1. Benzene alkylation with ethene over acid zeolite catalysts: (a) Benzene alkylation producing EB; (b) and (c) Polyalkylation producing di- and other polyethylbenzenes; (d) and (e) Transalkylation of polyethylbenzenes.....	24
Figure 2.2. Benzene alkylation with ethane over bifunctional Metal/H zeolite catalyst. D: dehydrogenation; M: migration of ethene from the metal to the acid site; A: alkylation of benzene with ethene.....	26
Figure 2.3. General scheme for benzene reactions with light alkanes.....	28
Figure 2.4. Reaction scheme of alkane aromatisation over metal containing H-ZSM-5 catalysts.....	30
Figure 2.5. Direct (one-step) dehydrogenation mechanism for ethane.....	32
Figure 2.6. Monomolecular protolytic cracking of light alkanes: cleavage of C-H bond (step 1) and cleavage of C-C bond (step2).....	33
Figure 2.7. Bimolecular protolytic cracking of light alkanes: hydride transfer (step 1) and β -scission (step 2).....	34
Figure 2.8. Light alkanes aromatisation over metal-containing catalysts. Bifunctional reaction scheme. (H^+)-protonic sites, (D)-dehydrogenation sites and (M)-migration (diffusion) steps.....	37
Figure 2.9. The reaction pathway of propane aromatisation over H-ZSM-5: Step (1) and (2) Alkane transformation into alkenes; Step (3)-(7) Alkene aromatisation.....	38
Figure 2.10. Primary reaction steps of benzene alkylation with propane over H-ZSM-5 catalyst.....	42
Figure 2.11. Main reactions of ethylbenzene over bifunctional catalysts: (a) isomerisation; (b) dealkylation; (c) transalkylation; (d) hydrogenolysis; (e) disproportionation.....	44
Figure 2.12. Ethylbenzene isomerisation over bifunctional catalyst with hydrogenated intermediates.....	45
Figure 2.13. Xylenes isomerisation: direct methyl migration around xylene aromatic rings.....	46
Figure 2.14. Disproportionation and transalkylation reactions of ethylbenzene: (a) molecular mechanism, (b) bimolecular mechanism.....	47
Figure 2.15. The channels and framework of ZSM5 zeolite.....	53
Figure 2.16. Brønsted acid sites in zeolites.....	53
Figure 2.17. Conversion of Brønsted acid sites to Lewis acid sites.....	54
Figure 2.18. Transformation of Lewis site to the <i>true</i> Lewis site.....	54
Figure 2.19. Schematic metal particle size distribution indicating three common measures of central tendency: (a) mode, (b) median, and (c) mean.....	56
Figure 2.20. The optimised structures of the active sites of monatomic Pt on H-ZSM-5.....	69
Figure 2.21. Scheme of the structure of the metal-support interface after reduction at 300°C and 450°C.....	70
Figure 3.1. Temperature profile of the calcination steps of H-ZMS-5 catalyst.....	73
Figure 3.2. Temperature profile of the calcination steps of PtH-ZMS-5 catalyst.....	74
Figure 3.3. Pipelines distribution.....	76
Figure 3.4. Gas distribution scheme 1.....	77
Figure 3.5. Gas distribution scheme 2.....	78
Figure 3.6. Catalytic rig layout.....	79
Figure 3.7. Schematic of the reactor set-up.....	82
Figure 3.8. Temperature profile of the activation of PtH-ZMS-5 catalyst in air at the flow of 30 ml/min.....	84
Figure 3.9. Temperature profile of the reduction of PtH-ZMS-5 catalyst in H_2 at the flow of 60 ml/min.....	84

Figure 3.10. The chromatograms of chemical components that detected by (a)-(c) FID and (d) TCD.....	90
Figure 3.11. Numeric form of peak areas obtained by (a) FID and (b) TCD.....	92
Figure 3.12. Benzene conversion as a function of time on stream (obtained from five individual runs).....	97
Figure 3.13. (a) Linear fit model of data points, (b) Residual plot of the model.....	97
Figure 3.14. (a) Polynomial fit model of data points, (b) Residual plot of the model.....	98
Figure 3.15. Temperature profile of the reduction of PtH-ZMS-5 catalyst in H ₂ prior to CO chemisorption.....	99
Figure 4.1. Thermodynamic equilibrium conversions of ethane dehydrogenation (Eq. 4.1) as a function of reaction temperature.....	105
Figure 4.2. Thermodynamic equilibrium conversions of benzene in benzene alkylation with ethane into EB and hydrogen (Eq. 4.3).	107
Figure 4.3. Thermodynamics equilibrium conversions of (■) benzene in benzene alkylation with ethane and (●) ethane in ethane dehydrogenation reaction.....	107
Figure 5.1. Effect of time on stream on benzene conversions over (■) 500 mg, (●) 200 mg and (▲) 50 mg of 1PtH-ZMS-5 catalyst at 370°C.	112
Figure 5.2. Schematic of the reactor set-up for the examination of temperature gradient in the catalyst layer.	115
Figure 5.3. Effect of time on stream on benzene conversion for benzene alkylation with ethane at 370°C over 1PtH-ZSM-5 catalyst (WHSV = 7.2 h ⁻¹).	116
Figure 5.4. Effect of time on stream on ethane conversion for benzene alkylation with ethane at 370°C over 1PtH-ZSM-5 catalyst (WHSV = 7.2 h ⁻¹).	117
Figure 5.5. Effect of time on stream on the concentrations of (■) hydrogen, (▲) EB and (●) ethene at 370°C over 1PtH-ZSM-5 catalyst (WHSV = 7.2 h ⁻¹).	117
Figure 5.6. Effect of time on stream on (■) benzene and (●) ethane conversions at 370°C over 1PtH-ZSM-5 catalyst (WHSV = 7.2 h ⁻¹).	118
Figure 5.7. Effect of time on stream on (■) ethene and (●) EB selectivity in all carbon containing products at 370°C over 1PtH-ZSM-5 catalyst (WHSV = 7.2 h ⁻¹).	119
Figure 5.8. Effect of contact time on (■) benzene and (●) ethane conversions over 1PtH-ZSM-5 catalyst at 370°C.....	120
Figure 5.9. Effect of ethane conversion on (■) EB, (▲) hydrogen and (●) ethene selectivity in all products over 1PtH-ZSM-5 catalyst at 370°C.....	120
Figure 5.10. Effect of time on stream on benzene conversion at (■) 490°C, WHSV = 7.2 h ⁻¹ , (▼) 370°C, WHSV = 7.2 h ⁻¹ , and (◀) 290°C, WHSV = 1.5 h ⁻¹	123
Figure 5.11. Effect of time on stream on ethane conversion at (■) 490°C, WHSV = 7.2 h ⁻¹ , (▼) 370°C, WHSV = 7.2 h ⁻¹ , and (◀) 290°C, WHSV = 1.5 h ⁻¹	124
Figure 5.12. Effect of time on stream on (■) EB and (●) ethene selectivity in carbon containing products at (a) 370°C and (b) 490°C, WHSV = 7.2 h ⁻¹	126
Figure 5.13. Effect of time on stream on (▲) methane, (▼) toluene, (◆) TEBs and (◀) other aromatics selectivity in carbon containing products at (a) 370°C and (b) 490°C, WHSV = 7.2 h ⁻¹	127
Figure 5.14. Effect of contact time on ethane conversion at (■) 490, (▼) 370, and (◀) 290°C.	128
Figure 5.15. Effect of contact time on benzene conversion at (■) 490, (▼) 370, and (◀) 290°C.	129
Figure 5.16. Effect of benzene conversion on (a) EB, (b) iPB, and (c) DEBs, selectivities in aromatic products at (■) 490, (▼) 370, and (◀) 290°C.....	131
Figure 5.17. Effect of benzene conversion on (a) TEBs, (b) toluene, and (c) other aromatics selectivities in aromatic products at (■) 490 and (▼) 370°C. These products were not observed at 290°C.....	132

Figure 5.18. Effect of ethane conversion on (■) EB, (▲) hydrogen and (●) ethene selectivity in all products over 1PtH-ZSM-5 catalyst at 490°C.....	135
Figure 5.19. Effect of contact time on (a) H ₂ , (b) ethene, and (c) EB concentrations at (■) 490 and (▼) 370°C.....	137
Figure 5.20. Effect of contact time on (a) methane, (b) propene, and (c) propane concentrations at (■) 490 and (▼) 370°C.....	138
Figure 5.21. Effect of contact time on (a) PBs, (b) DEBs, and (c) TEBs concentrations at (■) 490 and (▼) 370°C.....	139
Figure 5.22. Effect of contact time on (a) toluene, (b) ethyl-toluene, and (c) other aromatics concentrations at (■) 490 and (▼) 370°C.....	140
Figure 5.23. Effect of contact time on ethane conversion at (●) 450, (▲) 410, (▼) 370, and (◆) 330°C.....	143
Figure 5.24. Effect of contact time on benzene conversion at (●) 450, (▲) 410, (▼) 370, and (◆) 330°C.....	144
Figure 5.25. Effect of time on stream on benzene conversion at (●) 450°C, WHSV = 15.5 h ⁻¹ , (▲) 410°C, WHSV = 7.5 h ⁻¹ , (▼) 370°C, WHSV = 7.2 h ⁻¹ , and (◆) 330°C, WHSV = 3.1 h ⁻¹	145
Figure 5.26. Effect of time on stream on ethane conversion at (●) 450°C, WHSV = 15.5 h ⁻¹ , (▲) 410°C, WHSV = 7.5 h ⁻¹ , (▼) 370°C, WHSV = 7.2 h ⁻¹ , and (◆) 330°C, WHSV = 3.1 h ⁻¹	145
Figure 5.27. Effect of time on stream on (■) benzene and (●) ethane conversions at 450°C, WHSV ⁻¹ = 7.5 h ⁻¹	147
Figure 5.28. Effect of ethane conversion on (a) hydrogen, (b) ethene, and (c) EB selectivities in all products at (●) 450, (▲) 410, (▼) 370, and (◆) 330°C.....	149
Figure 5.29. Effect of benzene conversion on (a) EB, (b) iPB, and (c) xylene selectivities in all aromatic products at (●) 450, (▲) 410, (▼) 370, and (◆) 330°C.....	151
Figure 5.30. Effect of benzene conversion on (a) DEBs, (b) TEBs, and (c) toluene selectivities in all aromatic products at (●) 450, (▲) 410, (▼) 370, and (◆) 330°C.....	152
Figure 5.31. Effect of benzene conversion on (a) hydrogen, (b) ethene, and (c) EB concentrations at (●) 450, (▲) 410, (▼) 370, and (◆) 330°C.....	156
Figure 5.32. Effect of benzene conversion on (a) methane, (b) propane, and (c) propene concentrations at (●) 450, (▲) 410, (▼) 370, and (◆) 330°C.....	157
Figure 5.33. Effect of benzene conversion on (a) butanes, (b) butenes, and (c) xylenes concentrations at (●) 450, (▲) 410, (▼) 370, and (◆) 330°C.....	158
Figure 5.34. Effect of benzene conversion on (a) DEBs, (b) TEBs, and (c) ethyltoluene concentrations at (●) 450, (▲) 410, (▼) 370, and (◆) 330°C.....	159
Figure 5.35. Effect of benzene conversion on (a) toluene, (b) PBs, and (c) other aromatics concentrations at (●) 450, (▲) 410, (▼) 370, and (◆) 330°C.....	160
Figure 6.1. Effect of contact time on the concentrations of (■) H ₂ , (●) ethene, (▲) EB, (▼) propane, (◆) toluene, (◀) PBs, and (▶) DEBs formed during benzene alkylation with ethane over 1PtH-ZSM-5 catalyst at 370°C.....	166
Figure 6.2. Effect of contact time on the concentrations of (■) H ₂ , (●) ethene, (▲) EB, (■) propene, (●) butanes, (▲) xylenes, (▼) ethyltoluene, and (◆) other aromatics formed during benzene alkylation with ethane over 1PtH-ZSM-5 catalyst at 370°C.....	169
Figure 6.3. Effect of contact time on the concentrations of (■) PB, (●) DEBs, (▲) TEB, (■) methane, (●) propane, and (▲) toluene formed during benzene alkylation with ethane over 1PtH-ZSM-5 catalyst at 370°C.....	170
Figure 6.4. Effect of contact time on the concentrations of (■) iso-butane, and (●) n-butane formed during benzene alkylation with ethane over 1PtH-ZSM-5 catalyst at 370°C.....	171

Figure 6.5. Effect of contact time on the concentrations of (■) 1,3-DEB, (●) 1,4-DEB and (▲) 1,2-DEB formed during benzene alkylation with ethane over 1PtH-ZSM-5 catalyst at 370°C.	172
Figure 6.6. Effect of contact time on the concentrations of (■) 1,3- and 1,4-xylenes, and (●) 1,2-xylene formed during benzene alkylation with ethane over 1PtH-ZSM-5 catalyst at 370°C.	173
Figure 6.7. Reaction pathways of benzene alkylation with ethane into EB and hydrogen over 1PtH-ZSM-5 catalyst.	175
Figure 7.1. Effects of time on stream on (■) benzene and (●) ethane conversions over 1PtH-ZMS-5(80), and (■) benzene and (●) ethane conversions over 1H-ZMS-5(72) at 370°C, WHSV = 8.33 h ⁻¹	178
Figure 7.2. Effects of contact time on (■) benzene and (●) ethane conversions over 1PtH-ZMS-5(80), and (■) benzene and (●) ethane conversions over 1PtH-ZMS-5(72) at 370°C.	179
Figure 7.3. Effects of contact time on ethane conversion during benzene alkylation with ethane over (■) 1PtH-ZMS-5(72), and (◀) H-ZMS-5(72) at 370°C.	181
Figure 7.4. Effects of contact time on benzene conversion over (■) 1PtH-ZMS-5(72), and (◀) H-ZMS-5(72) at 370°C.	182
Figure 7.5. Effects of time on stream on (■) benzene and (●) ethane conversions over bare H-ZMS-5(72) at 370°C, WHSV = 8.33 h ⁻¹	183
Figure 7.6. Effect of contact time on (a) H ₂ , (b) ethene, (c) butanes concentrations over (■) 1PtH-ZMS-5(72), and (◀) H-ZMS-5(72) at 370°C.	185
Figure 7.7. Effect of contact time on (a) EB, (b) iPB, (c) toluene concentrations over (■) 1PtH-ZMS-5(72), and (◀) H-ZMS-5(72) at 370°C.	186
Figure 7.8. Effect of time on stream on ethane conversion over (■) 1, (●) 0.5, (▲) 0.1, (▼) 0.025, and (◆) 0.01PtH-ZSM-5 at 370°C, WHSV = 15.5 h ⁻¹	192
Figure 7.9. Effect of time on stream on benzene conversion over (■) 1, (●) 0.5, (▲) 0.1, (▼) 0.025, and (◆) 0.01PtHZSM-5 at 370°C, WHSV = 15.5 h ⁻¹	192
Figure 7.10. Effect of contact time on ethane conversion over (■) 1, (●) 0.5, (▲) 0.1, (▼) 0.025, and (◆) 0.01PtHZSM-5 at 370°C.	194
Figure 7.11. Effect of contact time on benzene conversion over (■) 1, (●) 0.5, (▲) 0.1, (▼) 0.025, and (◆) 0.01PtHZSM-5 at 370°C.	195
Figure 7.12. Effect of Pt loadings of PtH-ZSM-5 catalyst on ethane conversions at (■) 0.02 h, (●) 0.06 h, (▲) 0.13 h, (▼) 0.33 h, and (◆) 0.66 h of contact time at 370°C.	196
Figure 7.13. Effect of Pt loadings of PtH-ZSM-5 catalyst on benzene conversions at (■) 0.02, (●) 0.06, (▲) 0.13, (▼) 0.33, and (◆) 0.66 h of contact time at 370°C.	197
Figure 7.14. Effect of ethane conversion on (a) H ₂ , (b) ethene, and (c) EB selectivities in all products over (■) 1, (●) 0.5, (▲) 0.1, (▼) 0.025, and (◆) 0.01PtHZSM-5.	199
Figure 7.15. Effect of benzene conversion on (a) EB, (b) iPB, and (c) DEB selectivities in aromatic products over (■) 1, (●) 0.5, (▲) 0.1, (▼) 0.025, and (◆) 0.01PtHZSM-5.	201
Figure 7.16. Effect of benzene conversion on (a) toluene and (b) TEB selectivities in aromatic products over (■) 1, (●) 0.5, (▲) 0.1, (▼) 0.025, and (◆) 0.01PtHZSM-5.	202
Figure 7.17. Effect of contact time on (a) H ₂ , (b) ethene, and (c) EB concentrations over (■) 1, (●) 0.5, (▲) 0.1, (▼) 0.025, and (◆) 0.01PtHZSM-5.	206
Figure 7.18. Effect of contact time on (a) propane, (b) propene, and (c) toluene concentrations over (■) 1, (●) 0.5, (▲) 0.1, (▼) 0.025, and (◆) 0.01PtHZSM-5.	207
Figure 7.19. Effect of contact time on (a) PB, (b) DEB, and (c) TEB concentrations over (■) 1, (●) 0.5, (▲) 0.1, (▼) 0.025, and (◆) 0.01PtHZSM-5.	208

List of Tables

Table 2.1. Ethylbenzene production processes.....	23
Table 2.2. Thermodynamic equilibrium of DEB isomers	43
Table 3.1. Important gases and their functions.....	75
Table 3.2. Composition of calibration mixture.....	86
Table 3.3. Molecular weight of various components.....	95
Table 4.1. Thermodynamics data at 298K.....	102
Table 4.2. Thermodynamics equilibrium constants, K_p , at various reaction temperature.	104
Table 4.3. Thermodynamics data of ethane dehydrogenation reaction (Eq. 4.1) on pure ethane feed.....	104
Table 4.4. Thermodynamic data for the direct benzene alkylation with ethane (Eq. 4.3), feed ratio: 90 vol.% of ethane and 10 vol.% of benzene.....	106
Table 5.1. Selectivities to all carbon containing products of benzene alkylation with ethane over PtH-ZSM-5 catalyst at 370 and 490 °C.	141
Table 5.2. Selectivities to all aromatic products of benzene alkylation with ethane over PtH-ZSM-5 catalyst at different reaction temperatures, $\tau = 0.13$ h, TOS = 20 h.	146
Table 7.1. Selectivities to all carbon containing products of benzene alkylation with ethane over two 1PtH-ZSM-5 catalysts at 370°C, TOS = 20-24 h.	180
Table 7.2. Platinum dispersion and number of active platinum sites in PtH-ZSM-5 catalysts with 0.01 to 1 wt.% of Pt (these results were provided by Dr. Paul Millington at Johnson Matthey Technology Centre, Sonning Common).	193
Table 7.3. Selectivities to all products of benzene alkylation with ethane over PtH-ZSM-5 catalyst at 370°C, $\tau = 0.33$ h, TOS = 20-24 h.....	200

Abbreviation

0.01PtH-ZSM-5	Pt-containing (0.01 wt.%) ZSM-5 bifunctional catalyst
0.025PtH-ZSM-5	Pt-containing (0.025 wt.%) ZSM-5 bifunctional catalyst
0.1PtH-ZSM-5	Pt-containing (0.1 wt.%) ZSM-5 bifunctional catalyst
0.5PtH-ZSM-5	Pt-containing (0.5 wt.%) ZSM-5 bifunctional catalyst
1PtH-ZSM-5	Pt-containing (1 wt.%) ZSM-5 bifunctional catalyst
A	Alkylation of benzene with ethene
AA	Atomic absorption
Al	Aluminium
Al ₂ O ₃	Alumina
A _n (10>n>6)	Aromatics
B	Benzene
BAS	Brønsted acid site
BTX	Benzene, toluene, xylenes
C ₂	Ethane
C ₂ =	Ethene
C ₃	Propane
C ₃ =	Propene
C ₄	Butane
C ₄ =	Butene
C-C	Carbon-Carbon bond
C-H	Carbon-Hydrogen bond
D	Dehydrogenation
DEB	Diethylbenzenes

D _n (10>n>4)	Dienes
EB	Ethylbenzene
FID	Flame ionisation detector
Ga	Gallium
GC	Gas chromatograph
H-ZSM-5	Hydrogen form of ZSM-5 zeolite
ICP	Inductively coupled plasma
IPB	Isopropylbenzene
LAS	Lewis acid site
LPG	Liquefied Petroleum Gas
M	Migration of ethene from metal to acid site
m-DEB	Meta-diethylbenzene
MFC	Mass flow controller
NH ₄ -ZSM-5	Ammonium form of ZSM-5 zeolite
Ni	Nickel
o-DEB	Ortho-diethylbenzene
PB	Propylbenzene
Pd	Palladium
p-DEB	Para-diethylbenzene
PLOT-Al ₂ O ₃	Porous layer open tubular-alumina
Pt	Platinum
Pt(NH ₃) ₄ (NO ₃) ₂	Tetraamineplatinum(II)nitrate
Pt ⁰	Platinum atom
Pt ¹⁺ , Pt ²⁺	Platinum ions

Pt-O	Platinum-Oxygen bond
Ru	Ruthenium
SAXS	Small angle X-ray scattering
SEM	Scanning electron microscopy
SiO ₂	Silica
SPA	Supported phosphoric acid
TCD	Thermal conductivity detector
TEB	Triethylbenzenes
TEM	Transmission electron microscopy
TPR	Temperature program reduction
X _n (10>n>6)	Cyclic olefins
Y _n (10>n>6)	Cyclic dienes
Zn	Zinc

Nomenclature

d _{Pt}	Platinum particle diameter	nm
C _p	Specific heat capacity at constant pressure	J/mol·K
C _x	Molar percentage of species x	mol.%
D _{Pt}	Platinum dispersion	%
F _{in}	Molar flowrate of inlet	mol/h
F _{out}	Molar flowrate of outlet	mol/h
F _D	Molar flowrate of desired product	mol/h
F _P	Molar flowrate of product	mol/h
K _P	Equilibrium constant	

mw_x	Molecular weight of species x	g/mol
m_x	Mass of species x	g
N_s	Number of moles of surface metal atoms	mol
N_t	Total number of moles of metal atoms	mol
R	Universal constant	8.314 J/mol·K
R^2	Regression coefficient	
Sel_x	Selectivity of species x	mol.%
WHSV	Weight hourly space velocity	$g_{feed}/g_{cat}\cdot h$
X_{ben}	Benzene conversion	%
X_{C_2}	Ethane conversion	%
Y_x	Yield of species x	%
ΔG	Gibbs free energy of reaction	J/mol
ΔH	Enthalpy of the reaction	J/mol
ΔS	Entropy of the reaction	J/mol·K
τ	Residence time	s

Chapter 1

Introduction

Ethylbenzene (EB), which is one of the most important chemical intermediate products, is the primary feedstock for the synthesis of styrene that is subsequently polymerised into polystyrenes (Hancock, 1975). It was reported that in 2001 the world annual production capacity of EB was estimated to be 23 million metric ton per year, with an average annual growth rate of approximately 4% from 2001 to 2006, and over 90% of the production of EB is used in the manufacture of styrene (Degnan *et al.*, 2001). The Agency for Toxic Substances and Disease Registry (ATSDR, 1999) pointed out that EB is also used in the chemical industry in the manufacture of acetophenone, cellulose acetate, diethylbenzene (DEB), ethyl anthraquinone, ethylbenzene sulfonic acids, propylene oxide, and α -methylbenzyl alcohol. A mixture of EB and xylene is used as a solvent in the paint industry and for producing pesticides in agriculture (ATSDR, 1999).

In the 1930s, EB was first produced on the commercial scale in Germany and the United States. Its production was increased during World War II due to the high demand for synthetic polystyrene, i.e. butadiene rubber. The significant improvement in this technology led to the expansion in its capacity (Chemical Market Associates, 2004). The current industrial production of EB is based on benzene alkylation with ethene forming EB in the presence of an acidic catalyst (Degnan *et al.*, 2001). The overall equation of benzene alkylation with ethene is given as follows:

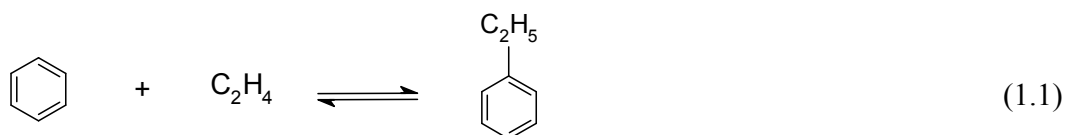

This conventional EB production route is accompanied by several consecutive reaction steps. About 5-15% of the EB reacts further with ethene forming DEB and about 10-20% of the DEB converts into triethylbenzene (TEB) by alkylation with ethene. A stoichiometric excess of benzene in the alkylation loop is able to minimise the alkylation of TEB with ethene forming polyethylated benzene. The DEB and TEB would be recovered and react with benzene in the transalkylation reactor reproducing EB (Netzer, 1999).

In the 1950s, roughly 40% of the world's EB capacity was produced in Friedel-Crafts liquid-phase alkylation with aluminium chloride-based (AlCl_3) catalysts (Degnan *et al.*, 2001). In the 1960s the AlCl_3 -based catalysts were proposed to be replaced by supported catalysts such as $\text{BF}_3/\text{Al}_2\text{O}_3$ and supported phosphoric acid (SPA) (Perego and Ingallina, 2002). However, the processes catalysed by SPA or AlCl_3 -based Friedel-Craft catalysts, suffer from serious environmental and corrosion problems (Smirnov *et al.*, 2000). Hoeldrich (2000) highlighted that the disposal of unavoidable side products formed in stoichiometric reactions, such as oxidation, has raised serious environmental problems. Moreover, the catalysts involved in the alkylation reactions, i.e. either strong mineral acids or Lewis acids, are highly toxic and corrosive, and are capable of corroding storage and disposal containers (Perego and Ingallina, 2002). Additionally, the catalyst-recycling step in solid phosphoric acid catalysed processes raises difficulties in the process arrangement. The necessity for complete removal of traces of catalyst from the product after catalyst deactivation, to avoid the deterioration of the product, is a further challenge faced in the processes catalysed by non-environmental friendly catalysts (Mitsutani, 2002).

The development of the process producing EB was improved significantly in the 1980s when a new gas-phase alkylation process using zeolite-based catalysts was commercialised, overcoming the main drawbacks of the AlCl_3 and SPA technology (Degnan *et al.*, 2001; Meyers, 2004; Perego and Ingallina, 2002). These zeolite catalysed processes are licensed by Mobil-Badger, Lummus-UOP, CDTech, and Dow Chemical (Degnan *et al.*, 2001), and these processes will be described in detailed in Chapter 2.

The environmental issues and regulations have been magnified in the public, political and economical world over the last fifteen years (Hoeldrich, 2000). In addition to catalysts upgrading, the development of the environmentally friendly chemical processes concentrate on the process optimisation and equipment improvement (Nexant, 2004). The process optimisation and equipment improvement such as minimising the energy consumption of the chemical processes would lead to the commercial and environmental benefits. The reduction of energy consumption would decrease the

emission of green house gases, namely carbon dioxide (CO₂), and reduces the operation cost of the process (Yoon, *et al.*, 2007).

As mentioned above, the current conventional process producing EB is based on benzene alkylation with ethene in the presence of an acidic catalyst (Degnan *et al.*, 2001). The ethene feed is produced from thermal cracking of hydrocarbons such as ethane, liquefied petroleum gas (LPG), naphtha, gas condensates, and gas oil (Ren *et al.*, 2006). Ren *et al.* (2006) pointed out that the highly endothermic steam cracking process, in which the energy input could be generated by direct burning of fuel, currently accounts for approximately 180-200 million tons of CO₂ emissions worldwide. Nevertheless, the energy cost contributes approximately 70% of the production costs in typical ethane- and naphtha-based alkenes plants (Ren *et al.* 2006). As a result, the process improvements, especially the replacement of ethene feed, in the current commercial EB production would be beneficial in terms of environmental and economic perspectives.

A number of authors have suggested the alternative catalytic reaction pathways for the production of EB. The catalytic reaction which uses ethane for benzene alkylation, instead of ethene, would eliminate the ethene production step and, thus, leading to the commercial and environmental benefits in the EB manufacturing (Lukyanov and Vazhnova, 2008a; Kato *et al.*, 2001; Smirnov *et al.*, 2000). The light alkanes such as ethane, propane and butane are the most insignificant and inexpensive hydrocarbons available in petrochemical industry which have not been involved in any efficient commercial processes up to date in spite of the significant research effort. This is mainly due to the high thermodynamic stability and very low reactivity of light alkanes making its activation and selective transformation into more valuable chemicals extremely difficult (Lukyanov and Vazhnova, 2008a). However, the credits and challenges of the light alkanes technology have attracted practical and scientific interest. In addition to benzene alkylation with ethane producing EB, another possible technology to upgrade these light alkanes would be the aromatisation reactions of light alkanes, producing a mixture of aromatic hydrocarbons such as benzene, toluene and xylenes (BTX).

The main objective of this project is to develop the new catalytic reaction pathways for the production of EB *via* direct benzene alkylation with ethane at relatively low reaction temperature. The underlying idea of this project is to couple the ethane dehydrogenation into ethene over metal sites and benzene alkylation with ethene over Brønsted acid sites (BAS) using bifunctional zeolites catalysts, and to carry out the study and development of this novel chemistry at relatively low temperatures (290 – 490°C). The thermodynamic equilibrium dehydrogenation conversions of ethane were relatively low at these temperatures. Hence, practically no research has been performed at these temperatures to date.

Thermodynamic equilibrium is a dynamic phenomenon and it is possible to bypass the thermodynamic limitations for ethane dehydrogenation reaction by trapping ethene molecules with benzene *via* the alkylation reaction into EB. The efficiency of the overall EB formation over the bifunctional catalyst should depend on the rates of the dehydrogenation and alkylation reactions, and these rates are affected by the nature and number of metal and acid sites in the bifunctional catalyst. As a result, the proper balance of the acid and metal sites of the bifunctional catalyst could be critical in order to achieve high catalyst yield and selectivity. The catalyst stability could be enhanced by operating at low reaction temperatures. Low ethane conversion was achieved in the temperature range of 290 – 490°C which would induce low ethene concentration at any point in the reactor and, hence, the low rate of dimerisation of ethene, which is the initial reaction step in the sequence of alkene oligomerisation, aromatisation and cracking reactions. The low concentrations of alkenes are expected to suppress the side reactions and enhance the catalyst stability, as alkenes are known as important contributors to the coke formation over zeolites catalysts.

The research started with the detailed literature review on the current commercial processes producing EB and the proposals improving EB production. In-depth reviews on primary and secondary reaction steps of the proposed EB production routes were carried out, followed by the introduction of the catalysts for benzene alkylation with

light alkanes. The preliminary investigation focused on the feasibility of benzene alkylation with ethane into EB over 1PtH-ZSM-5 bifunctional catalyst at low temperature. The selection of the reaction temperature and the catalyst for preliminary investigation was based on the analysis of the thermodynamic and kinetic limitations of this reaction as well as the up to date literature. Then, the detailed analysis on the thermodynamic equilibrium conversions of the overall benzene alkylation with ethane producing EB and hydrogen, and ethane dehydrogenation into ethene and hydrogen were carried out in order to establish the temperature range for further investigation. The temperature analyses focused on the effects of reaction temperatures on the catalyst performances for benzene alkylation with ethane into EB over Pt-containing (1 wt.%) ZSM-5 bifunctional catalyst, defined as 1PtH-ZSM-5. Additionally, the effects of temperatures on the reaction pathways, the rates of reaction steps and the product distributions were studied, and based on these results, determining the optimum reaction temperature for benzene alkylation with ethane producing EB over 1PtH-ZSM-5 bifunctional catalyst.

Prior to the optimisation of catalyst composition, the detailed reaction pathways of benzene alkylation with ethane into EB over PtH-ZSM-5 catalyst were established. The understanding of detailed reaction pathway is important in catalyst optimisation as the rates of desired and undesired reaction steps could be altered by adjusting the nature and number of metal and acid sites in the catalyst. The next stage of the research focused on the development of the promising catalyst for benzene alkylation with ethane into EB. The reaction was catalysed by PtH-ZSM-5 bifunctional catalysts with metal loading ranging from 0 to 1 wt.% and the effects of metal loadings on the reaction pathways and the rates of reaction steps were studied. In conclusion, the initial stage of the project was to evaluate the feasibility of benzene alkylation with ethane into EB over Pt-containing bifunctional catalyst, then the process modification was carried out in order to achieve better catalyst performances.

Chapter 2

Literature Review

2.1. Commercial ethylbenzene production

It was discussed in Chapter 1 that the current commercial production of EB is based on benzene alkylation with ethene forming EB in the presence of an acidic catalyst, such as zeolites, under moderate reaction conditions. These zeolite catalysed processes are licensed by Mobil-Badger, Lummus-UOP, CDTECH, and Dow Chemical. Table 2.1 shows the reaction conditions and the types of catalysts involved in each commercial EB production processes.

Table 2.1. Ethylbenzene production processes (Degnan *et al.*, 2001).

Process	Monsanto -Lummus (<1975)	Mobil- Badger (1980)	Lummus/ UOP (1989)	Mobil- Badger (1990)	CDTECH EB (1994)	EBMax (1995)	EBOne (1996)
T (°C)	160	390-440	240-270	390- 440	-	240-270	-
Catalyst	AlCl ₃	ZSM-5	Y	ZSM-5	Y	MCM-22	EBZ-500
Phase	Liquid	Vapor	Liquid	Vapor	-	Liquid	Liquid
Feed ratio (B/C ₂ =)	2.5	7.6	7.2	7.6	-	4	4-6
Life (yr)	-	0.25	1	1	5	3	2

The first step of the commercial EB production is the reaction between benzene and ethene forming EB (Fig. 2.1a) and the EB could further react with ethene forming DEBs (Fig. 2.1b) and TEBs (Fig. 2.1c). The later reactions are known as polyalkylation and the products of these reactions are polyethylbenzenes. Subsequently, the transalkylation of polyethylbenzenes could take place until the thermodynamic equilibrium is reached (Fig. 2.1d and e). These typical acid catalysed benzene alkylation reactions are followed by a number of side reactions. The oligomerisation of light alkenes leads to the formation of larger alkenes and these very reactive large alkenes could crack into smaller alkenes. The smaller alkenes alkylate benzene forming polyalkylbenzenes. Additionally, the transalkylation of EB forming xylene is also one of

the side reactions that decreases the EB concentration in the product mixture (Degnan *et al.*, 2001 and Perego and Lngallina, 2002).

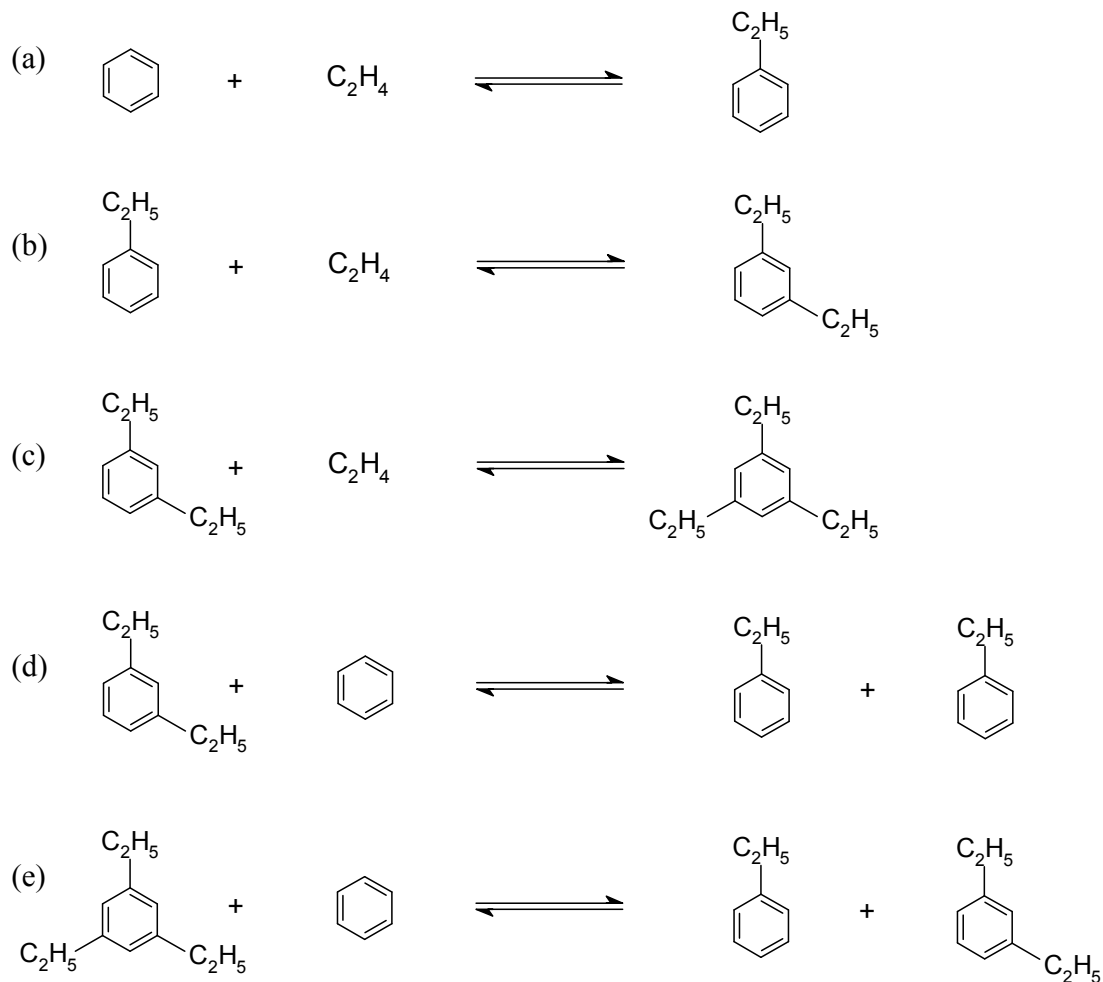

Figure 2.1. Benzene alkylation with ethene over acid zeolite catalysts: (a) Benzene alkylation producing EB; (b) and (c) Polyalkylation producing di- and other polyethylbenzenes (Perego and Lngallina, 2002); (d) and (e) Transalkylation of polyethylbenzenes (Degnan *et al.*, 2001).

The Mobil-Badger vapour phase process was first introduced in 1980 and is still the most widely used zeolite catalysed EB manufacturing process. In the Mobil-Badger process, the gas phase benzene alkylation with ethene over ZSM-5 acid catalyst is carried out in a fixed-bed reactor. The fresh and recycled benzene is combined with a

DEB-rich recycle stream and fed, together with fresh ethene, to an alkylation reactor. The process has the overall EB yield of at least 99%. The second and third generations of Mobil-Badger process has improved significantly in terms of cycle length and product yields. The cycle length was improved from 60 days to more than 1 year, and yields improved to greater than 99.5%. Additionally, the Mobil-Badger process has been modified to use dilute ethene from FCC off-gas streams as a feedstock (Degnan *et al.*, 2001).

EBMax is a liquid phase EB process that uses Mobil's proprietary MCM-22 zeolite as the catalyst. The highly selective and stable MCM-22-based catalyst has lowered feed ratios of benzene to ethene to the range of 3 to 5. The lower benzene to ethene ratios reduces the capacity of recycled benzene which, in turn, improves the efficiency and reduced the throughput of the benzene recovery column. The EBMax operates at low temperatures (240-270°C), and therefore low concentrations of side products, such as xylenes, propylbenzene etc., were achieved. In 1989, Lummus-UOP process was introduced. It is a liquid-phase process based on a modified zeolite Y catalyst and the process design is similar to the Mobil-Badger EBMax process (Degnan *et al.*, 2001).

2.2. Benzene alkylation with light alkanes

Benzene alkylation with ethene has been the principle reaction for the manufacture of EB since it was first introduced in the 1930s (Chemical Market Associates, 2004). Due to the reasons stated in Chapter 1, light alkanes have been considered during the last decade, as a potential feedstock to replace alkenes in benzene alkylation reactions. Such alkanes, are ethane and propane, are among the most abundant and cheap hydrocarbons available today and are, indeed, commercially attractive. Recently, significant research efforts have been devoted to the investigation of direct benzene alkylation with light alkanes, i.e. ethane and propane (Bigey and Su, 2004; Kato *et al.*, 2001; Smirnov *et al.*, 2000). All authors arrived at the conclusion, which is that light alkanes would undergo dehydrogenation to form light alkenes before the alkylation reaction with benzene in the presence of bifunctional catalysts and the overall reaction is given as follows (Eq. 2.1):

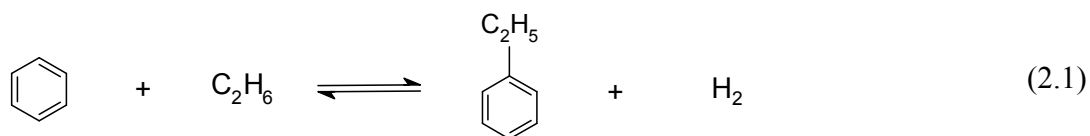

Caeiro *et al.* (2006) and Woltz *et al.*, (2005) illustrated that benzene alkylation with light alkanes catalysed by the bifunctional catalysts that consist of metal sites, catalysing the hydrogenation/dehydrogenation steps, and acidic sites, responsible for the formation of carbenium ions which is the most important intermediates for benzene alkylation forming EB (Fig. 2.2).

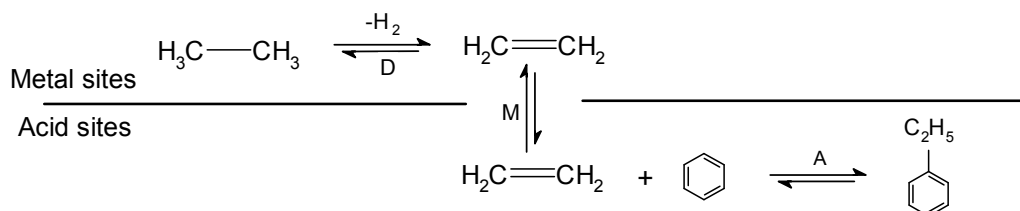
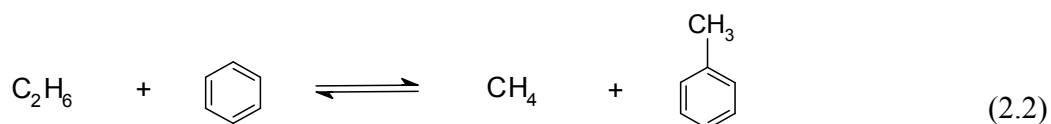

Figure 2.2. Benzene alkylation with ethane over bifunctional Metal/H zeolite catalyst. D: dehydrogenation; M: migration of ethene from the metal to the acid site; A: alkylation of benzene with ethene (Caeiro *et al.* 2006).

The possibility of catalytic direct benzene alkylation with light alkanes was first reported by Olah *et al.* (1975). The EB yield over the fluoroantimonic acid catalyst ($\text{HF}-\text{SbF}_5$) was low (1 mol%), but the selectivity was considerable high (76 mol%). Later on, Ivanova *et al.* (1996) and Bigey and Su (2004) demonstrated direct benzene alkylation with propane over Ga-containing ZSM-5 catalysts, which overcome the environmental and corrosion problems caused by the superacidic catalysts. Almost no activity was observed for benzene alkylation with propane over H-ZSM-5 catalyst at reaction temperature lower than 500°C . The benzene conversion was about 7% at 500°C over Ga-containing ZSM-5 catalyst and the desired products, cumene (isopropylbenzene) and n-propylbenzene, are produced in small amounts, i.e. low selectivity to the products of direct alkylation. The low benzene alkylation activity is mainly due to thermodynamic

factors that propane dehydrogenation is highly endothermic and temperatures above 800°C are required to favour its activation (Bigey and Su 2004).

Kato *et al.* (2001) and Smirnov *et al.* (2000) carried out investigation on direct alkylation of benzene with ethane and propane, respectively, over Pt-containing H-ZSM-5 catalysts. Kato *et al.* (2001) investigated the effect of temperature (450-550°C) and platinum loading on the yield of EB in benzene alkylation with ethane over Pt-loaded zeolite catalyst and demonstrated that ZSM-5 and MCM-22 with moderate acid strength distribution showed better catalytic activities. It was suggested that in benzene alkylation with ethane over Pt-containing zeolite catalyst, ethene was initially produced from ethane dehydrogenation over metallic platinum, followed by benzene alkylation with ethene over acid sites. The highest EB yield (benzene-based) of 7.3% was reported for 500°C, but no data on benzene and ethane conversions as well as on the product selectivities were discussed. Smirnov *et al.* (2000) and (2001) carried out more detail investigation of benzene alkylation with light alkanes (ethane, propane and isobutane) over Pt-containing H-ZMS-5 catalysts in the temperature range of 250°C-450°C and suggested a general reaction network (Fig. 2.3). The detailed benzene alkylation with ethane over PtH-ZSM-5 catalyst was investigated at 450°C and the highest selectivities to EB in all products and in the aromatic products were 27 and 43 mol.%, respectively, at ethane conversion of 16%. Smirnov *et al.* (2001) suggested that the main reaction mechanisms for benzene alkylation with ethane were the hydrocracking of ethane forming methane and the dehydrogenation of ethane forming ethene followed by benzene alkylation producing EB. It was proposed that the high toluene concentration could be due to benzene alkylation with ethane forming methane and toluene (Eq. 2.2) and/or transalkylation of ethylbenzene (Eq. 2.3).



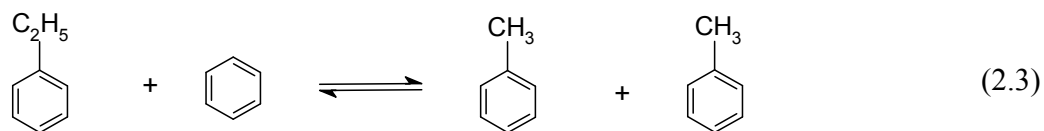

As shown in Fig 2.3, the alkylation of benzene with light alkanes over the bifunctional catalysts is accompanied by various side reactions. These side reactions have negative effects on the rates of production of the desired products. In order to achieve the maximum yield of the desired products, it is essential to search ways to suppress these side reactions. However, there is no direct information on the detailed reaction mechanism of the benzene alkylation reaction available in the current literature. Thus, the study and development of the detailed reaction mechanisms of benzene alkylation with light alkanes is essential in improving the product yields.

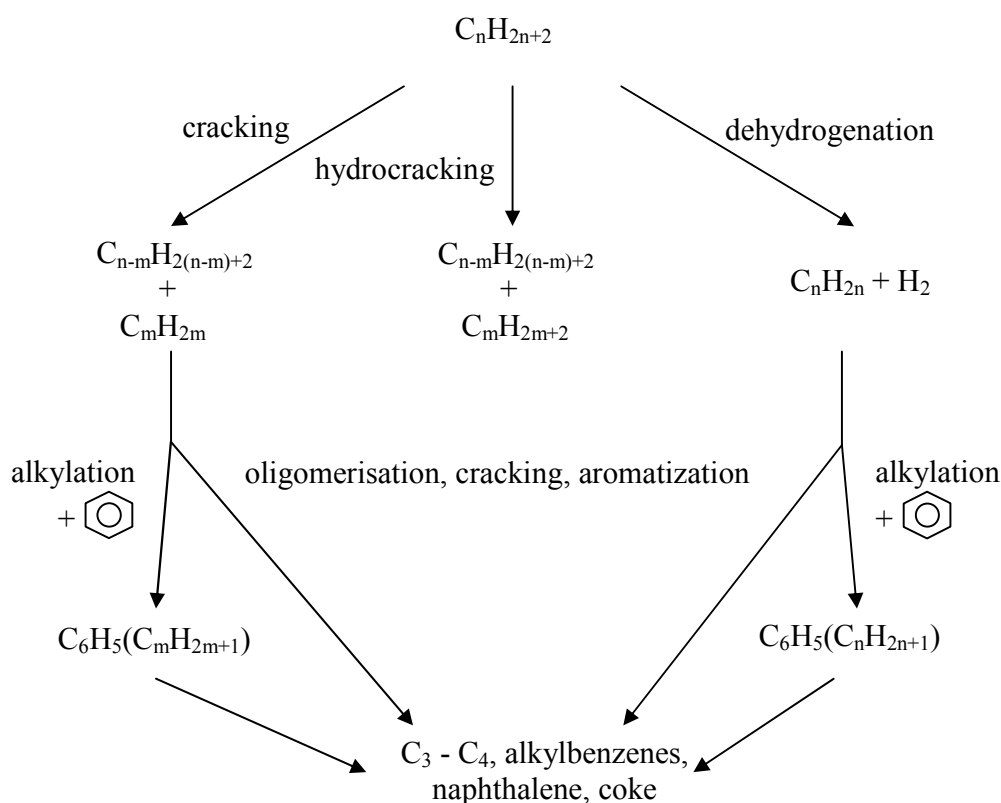

Figure 2.3. General scheme for benzene reactions with light alkanes (Smirnov *et al.*, 2001).

2.2.1. Conversion of light alkanes into light alkenes and aromatics hydrocarbon

As mentioned in the above sections, it is widely agreed that in benzene alkylation with light alkanes, light alkanes convert, first, into light alkenes, and then the converted light alkenes alkylate benzene forming alkybenzene (Bigey and Su, 2004; Kato *et al.*, 2001; Smirnov *et al.*, 2000). Hence, the activation of light alkanes is the first step of the multi-step reaction. The activation of the light alkanes is more difficult than that of other hydrocarbons due to the high thermodynamic stability of the light alkanes (Banares, 1999). The low reactivity of light alkanes has hindered their use in industrial processes. As a result, despite the large reserves of light alkanes from natural gas or as liquefied petroleum gas (LPG), limited numbers of industrial processes are operative for the conversion of light alkanes. The three main commercial processes which aromatise light alkanes into benzene, toluene and xylenes (BTX), are M-2 forming (Mobil), Cyclar (BP-UOP) and Aroforming (IFP-Salutec) (Banares, 1999 and Guisnet and Gnep, 1992).

The M-2 forming process convert a large variety of feed-stocks, such as pyrolysis gasoline, paraffinic naphthas and LPG, into aromatics using H-ZMS-5 catalyst. The operating temperature depends on the reactivity of the feedstock, for example 538°C for the aromatisation of propane. However, the pure acid catalyst is efficient only for the production of high octane compounds from pyrolysis gasoline or paraffic naphthas. Indeed, a bifunctional catalyst is necessary for the conversion of LPG into aromatics. The Cyclar process is catalysed by gallium containing zeolite catalysts and yielded 63.1 wt.% of aromatics, 5.9 wt.% of hydrogen and 31 wt.% of fuel gas when propane is used as a feedstock. The large scale pilot plant at British Petroleum Grangemouth Refinery has 1000 barrel per day capacity with 65 wt.% of aromatics (benzene 19.5 wt.%; toluene 27.3 wt.%; xylenes 13 wt.%, others 5.2 wt.%), 6 wt.% of hydrogen and 29 wt.% of fuel gas and the catalyst life is expected to be around 2 years. The Aroforming process was designed to convert light naphtha (especially C₅ and C₆ alkanes) or LPGs into aromatics using metal oxides containing zeolite catalysts. The main problem of Cyclar and Aroforming processes is the production of large amount of fuel gas by cracking and

research efforts have been focused on developing the new catalyst formulations which yielded low cracking activity (Guisnet and Gnep, 1992).

The conversion of light alkanes into aromatics (BTX) over acid support catalyst is a complicated reaction that comprises numerous successive steps (Guisnet and Gnep, 1992). It is suggested, by various research groups, that the transformation of light alkanes over ZSM-5 supported catalyst proceeds through three main stages: (i) transformation of alkanes into alkenes, (ii) interconversion of the alkenes, and (iii) alkene aromatisation (Fig 2.4) (Biscardi and Iglesia, 1998; Haag and Dessau, 1984; Lukyanov *et al.*, 1995; Nguyen *et al.*, 2006).

1. Alkane transformation into alkenes

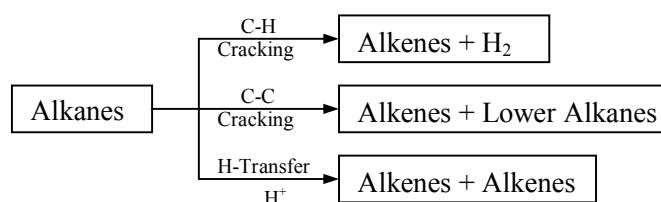

2. Alkene oligomerisation and cracking

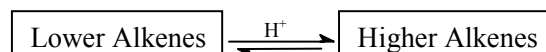

3. Alkene aromatisation

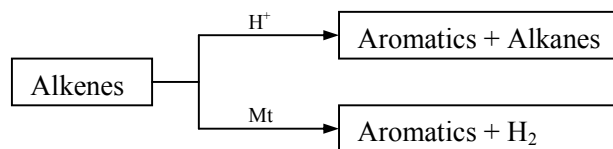
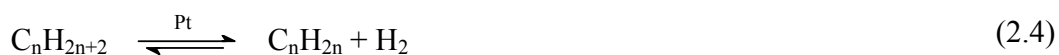

Figure 2.4. Reaction scheme of alkane aromatisation over metal containing H-ZSM-5 catalysts (Nguyen *et al.*, 2006).

2.2.1.1. The primary transformation of light alkane

The first step of light alkane transformation over metal-containing ZSM-5 catalysts is the alkane dehydrogenation forming the corresponding alkenes and hydrogen. According to Bhasin *et al.* (2001), the main reaction in catalytic dehydrogenation over a bifunctional catalyst is the formation of mono-alkenes from the corresponding feed alkanes over the metal sites of the catalyst. The incorporation of metals into H-ZSM-5 catalyst provides an additional dehydrogenation path (Eq. 2.4), without significantly affecting the rate of the acid-catalysed transformation (Kwak *et al.*, 1994).



Several bifunctional reaction mechanisms for light alkane dehydrogenation over Ga-containing H-ZSM-5 catalysts were proposed (Bigey and Su, 2004; Caeiro *et al.*, 2006; Derouane *et al.*, 2000; Guisnet *et al.*, 1992; Joshi and Thomson, 2005). Guisnet and Gnep (1992) highlighted that all the proposed bifunctional mechanisms require the close proximity of the metal and protonic sites. Bigey and Su (2004) and Derouane *et al.* (2000) proposed that the GaH-ZSM-5 catalysed dehydrogenation of propane involves double acidic sites, where metal species acting as Lewis sites and protonic sites is the Brønsted acid site (BAS). It is suggested that in this bifunctional mechanism, pseudo-cyclopropanes are formed initially over metal oxide. These pseudo-cyclopropanes are further protonated by the Brønsted acid sites and form protonated pseudo-cyclopropanes. The dehydrogenation of protonated pseudo-cyclopropanes produces propyl carbenium ions which can lead to propene by reaction with carbenium ions. The protonated pseudo-cyclopropanes can also decompose into ethyl carbenium ion (C_2H_5^+) and methane or ethane and a methyl carbenium ion (CH_3^+). These carbenium ions react on zeolite acid sites forming light alkenes (Bigey and Su, 2004 and Derouane *et al.*, 2000).

Meriaudean and Naccache (1990) suggested a bifunctional mechanism of propane dehydrogenation over Ga/H-ZSM-5 catalyst. The first step of the bifunctional mechanism is the dissociative adsorption of propane forming gallium hydride and gallium alkoxide species (Eq. 2.5). The unstable propyl carbenium ions, formed over

gallium oxide, will exchange with zeolite protons through an alkyl surface migration reaction (Eq. 2.6). The final step consists of the desorption of propene from the zeolite (Eq. 2.7) (Guisnet and Gnep, 1992; Meriaudeau and Naccache, 1990).

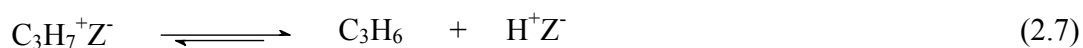
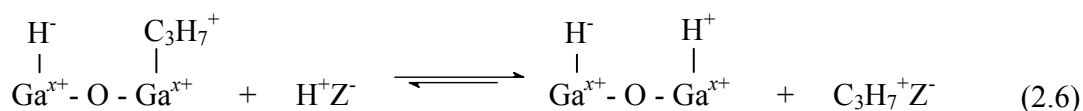
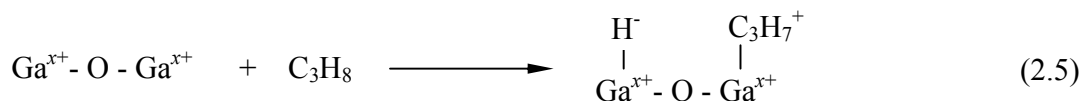

Joshi and Thomson (2005) proposed the direct (one-step) dehydrogenation of the hydrocarbon over a Ga/HZSM5 bifunctional catalyst (Fig. 2.5).

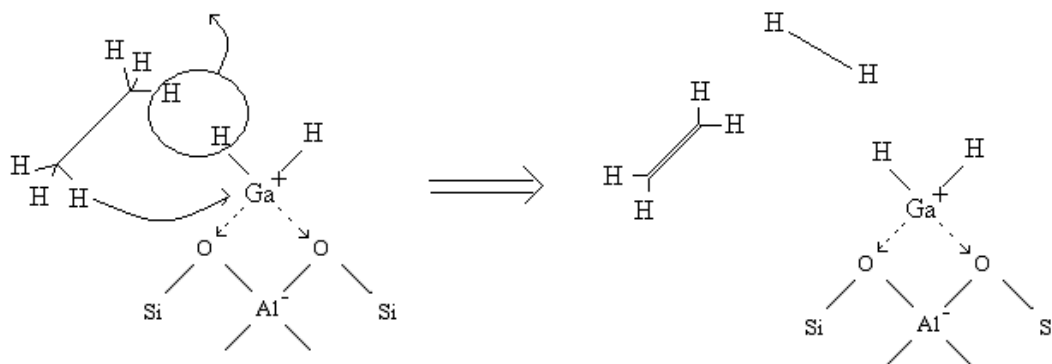

Figure 2.5. Direct (one-step) dehydrogenation mechanism for ethane (Joshi and Thomson, 2005).

The hydrogen from one of the alkane carbons combines with hydrogen from the active Ga site to form molecular hydrogen. At the same time, the hydrogen from the other carbon atom replaces the Ga-H coordination. Thus, there is a formation of an

alkene and molecular hydrogen in one-step, and at the same time the catalytic site is regenerated (Joshi and Thomson, 2005).

Despite the dehydrogenation steps, which are catalysed by the metal sites, the light alkane could be transformed *via* two acid catalysed routes: (i) monomolecular protolytic cracking route, i.e. the cleavage of carbon-carbon (C-C) and carbon-hydrogen (C-H) bonds in alkanes molecules, and (ii) bimolecular hydrogen transfer route which involve the reaction between the alkane with the product alkenes adsorbed on the acid site of the zeolites (Caeiro *et al.*, 2006; Guisnet *et al.*, 1992; Haag and Dessau, 1984; Lukyanov *et al.*, 1995; Nguyen *et al.*, 2006).

The monomolecular mechanism of protolytic cracking of light alkanes suggests that the light alkanes are protonated on the BAS of the H-ZSM-5 catalyst at high temperatures to form the unstable transition species known as carbonium ion. These unstable carbonium ions can easily collapse and produced carbenium ion and hydrogen (H₂) (Fig. 2.6: step 1) or lower alkanes (Fig. 2.6: step 2). These carbenium ions further convert into various products, such as alkenes, in the presence of the acid sites (Bigey and Su, 2004; Caeiro *et al.*, 2006).

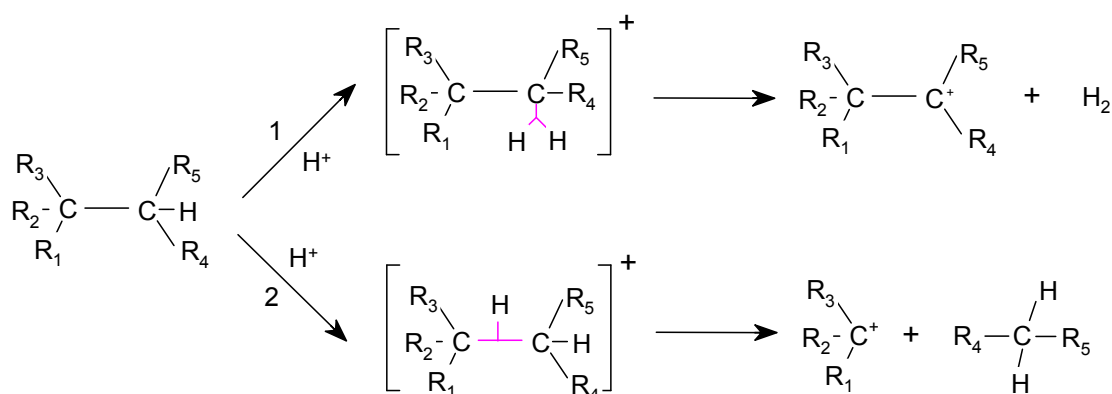

Figure 2.6. Monomolecular protolytic cracking of light alkanes: cleavage of C-H bond (step 1) and cleavage of C-C bond (step2) (Caeiro *et al.*, 2006).

The scission of the alkane into H_2 and carbenium ion occurs through protolysis of C-H bond while the scission into lower alkanes and carbenium ion happens through the cleavage of C-C bond. The protolytic cleavage of C-C bonds occurs faster than that of the C-H bond regardless the degree of substitution of the carbon atoms. For example, the scission of the $C_{II}-C_I$ and $C_{II}-C_{II}$ bonds of propane are 2 to 3 times more rapid than the scission of the $C_{II}-H$ bond (Guisnet *et al.*, 1992). As a result, the protolytic cracking (Fig. 2.6: step 2) is faster than the protolytic dehydrogenation (Fig. 2.6: step1) (Guisnet and Gnep, 1992). Guisnet *et al.* (1992) pointed out that the rate of C-H bond cleavage increases with the stability of the carbonium ions and the resulting carbenium ions involved in β -scission. The stability of the carbenium ions increases with their degree of substitution: tertiary > secondary > primary > methyl (Caeiro *et al.*, 2006). Thus, the rate of C-H bond cleavage is 30 times higher with isobutane (tertiary carbocation) than with ethane (primary carbocations). On the other hand, the cleavage of C-C bond increases with the stability of the carbonium ion intermediate but independent on the stability of the resulting carbenium ion (Guisnet *et al.*, 1992).

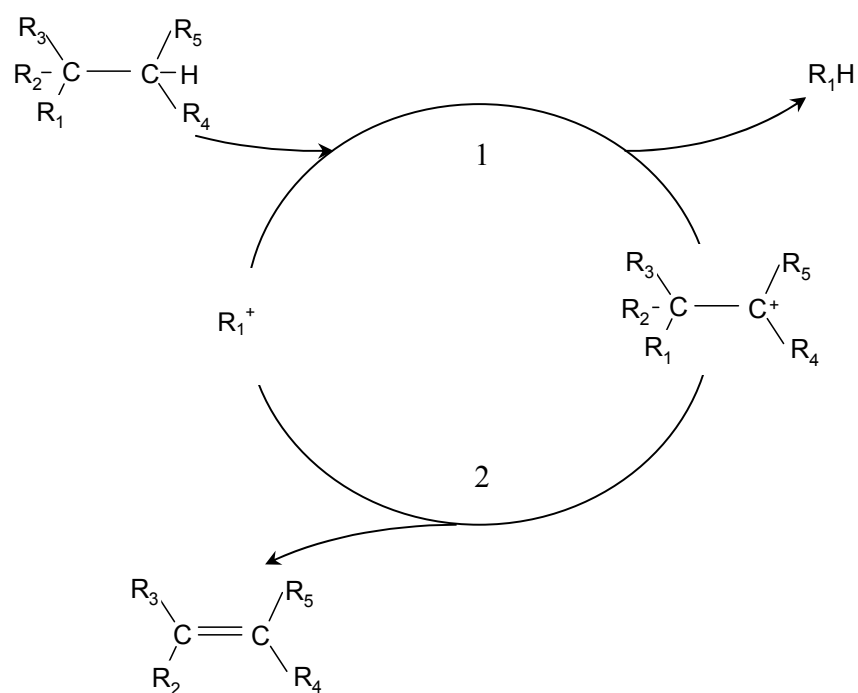

Figure 2.7. Bimolecular protolytic cracking of light alkanes: hydride transfer (step 1) and β -scission (step 2) (adapted from Caeiro *et al.*, 2006).

The bimolecular hydrogen transfer of light alkane proceeds through the carbenium ion chain mechanism. The propagation step of the carbenium ion chain mechanism is the hydride transfer between an alkane and carbenium ion (Fig. 2.7: step 1), followed by the β -scission of the resulting carbenium ion and produces an alkene and carbenium ion (Fig 2.7: step 2) (Caeiro *et al.*, 2006; Haag and Dessau, 1984; Nguyen *et al.*, 2006). Haag and Dessau (1984) pointed out that the carbenium ions involve in the hydride transfer step could be the product alkenes protonated on the acid sites of the zeolite.

Nguyen *et al.* (2006) pointed out that the metal species has provided additional dehydrogenation routes for the alkane conversion into corresponding alkene and for the transformation of alkenes into aromatics and hydrogen. However, this bifunctional mechanism is accompanied by various side reactions, such as the hydrogenolysis of alkane on metal sites (Caeiro *et al.*, 2006).

The hydrogenolysis of light alkanes (such as ethane) is known as a structure sensitive reaction that takes place on some special sites of the catalyst (Marecot *et al.*, 1989; Raddi *et al.*, 2000). The hydrogenolysis reaction is believed to occur on the metal sites of the bifunctional catalysts, and Guzzi and Gudkov (1978) proved that the rate of hydrogenolysis is affected by the metal particle size. Additionally, investigations by Nayssilov (1993) have shown that the hydrogenolysis of light alkanes is sensitive towards metal type and metal surface structure and the reaction requires relatively large and suitably situated group of active centers.

Hydrogenolysis of light alkanes includes the breaking of the C-C bond in the alkane molecule, and is followed by the hydrogenation of the hydrocarbon fragments obtained as a result of the breaking of C-C bonds (Nayssilov, 1993). Cortright *et al.* (1999) and Nayssilov (1993) proposed that the first step of hydrogenolysis of ethane is the dissociative adsorption of ethane by means of cleavage of a C-H bond (Eq. 2.8). The obtained ethyl carbenium ion undergoes additional dehydrogenation forming the basic surface intermediate $C_2H_x(ads)$ (Eq. 2.9). The following step is the breaking of C-C bond of $C_2H_x(ads)$ intermediate and leads to the formation of adsorbed particles

containing one carbon atom (Eq. 2.10). Finally, the hydrogenation of the surface CH_y particles forms methane (Eq. 2.11).

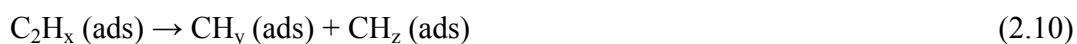
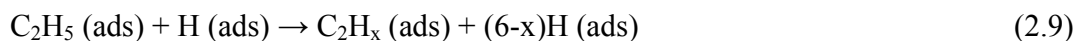

Mroczek *et al.* (1991) illustrated that the presence of hydrogen in the gas phase favoured hydrogenolysis of light alkanes but suppressed the dehydrogenation and aromatisation reactions. As a result, aromatisation reaction is disfavoured, inhibiting the formation of aromatics, which is the main source of the coke formation.

The transformation of light alkanes over physical mixture catalysts could occur through the bifunctional mechanisms, which involves successive chemical steps on the two types of sites and the diffusion steps of desorbed intermediates from one active site to another active site (Caeiro *et al.*, 2006). It is assumed that the metal oxide is in close proximity with the BAS of the zeolite and the activation of the light alkanes, over physical mixture catalysts, possibly takes place either at the interface between the metal and the zeolites or on the metal oxide (Buckles and Hutchings, 1996). Buckles and Hutchings (1996) suggested that the first step of light alkane transformation on physical mixture bifunctional catalyst is the activation of light alkane on the metal oxide forming an intermediate. Then, the intermediate transfers *via* the gas phase and subsequently reacts on zeolites acid site forming light alkene.

2.2.1.2. The secondary transformation of alkane

The second stage of alkane transformation is the interconversion of alkene, which includes alkene isomerisation, oligomerisation and cracking steps (Nguyen, *et al.*, 2006). Light alkenes, initially formed *via* dehydrogenation and cracking of light alkanes, undergo rapid acid-catalysed chain growth reactions within the zeolite channels by oligomerisation forming oligomers ($\text{C}_4\text{-C}_{10}$) and these oligomers could crack into

smaller alkenes. As the chain increases, cracking reactions become faster and, ultimately, a large number of alkyl carbenium ions are formed *via* hydrogen transfer. The small alkyl carbenium ions undergo further hydrogen transfer, in which light alkenes accept hydrogen to form alkanes. Larger alkyl carbenium ions (such as C_6^+) are cyclised preferably and after a number of hydrogen-transfer steps, form kinetically stable and thermodynamically favoured aromatic products (Fig. 2.8). The formation of aromatics *via* hydrogen transfer is balanced by alkanes formation, and this limits the production of aromatics. (Biscardi and Iglesia, 1998; Lukyanov *et al.*, 1995).

The bifunctional scheme for light alkane aromatisation involves chemical and physical steps (Fig. 2.8). Steps 1, 5, 9 and 10 can occur through dehydrogenating sites, while steps 3 and 7 (oligomerisation-cracking and cyclisation) should be catalysed by the protonic acid sites. Steps 2, 4, 6 and 8 are the migration steps of the desorbed intermediates from metal sites to the acid sites and *vice-versa*. In the aromatisation of light alkanes over pure acidic catalyst (H-ZSM-5), the zeolite protonic sites are able to catalyse steps 1, 5, 9, and 10. Step 1 occurs partly through protolysis and partly through hydride transfer (Fig. 2.6 and 2.7), while steps 5, 9, and 10 occur through hydride transfer (Caeiro *et al.*, 2006; Lukyanov *et al.*, 1995). Guisnet and Gnep (1992) highlighted that the acid process continues to operate in bifunctional scheme, the acid sites and the metal species intervening simultaneously in steps 1, 5, 9 and 10.

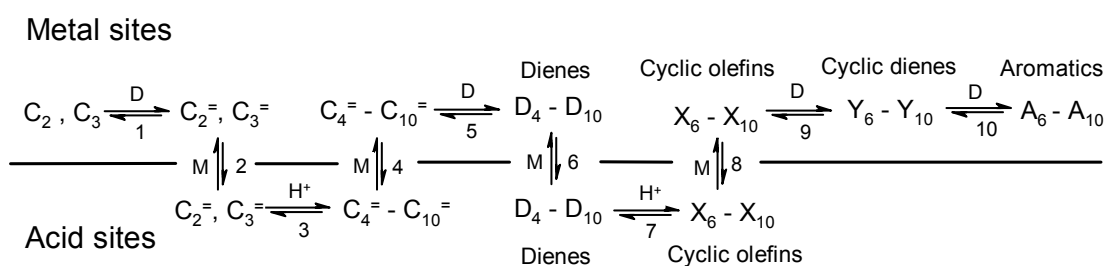

Figure 2.8. Light alkanes aromatisation over metal-containing catalysts. Bifunctional reaction scheme. (H^+)-protonic sites, (D)-dehydrogenation sites and (M)-migration (diffusion) steps (based on Caeiro *et al.*, 2006; Lukyanov *et al.*, 1995).

A high reaction temperature is necessary for alkane aromatisation and light alkenes are thermodynamically favoured in comparison to the larger alkenes at high temperature. Hence, cracking is more favourable than oligomerisation and alkylation reactions, and thus, very low concentration of C₅₊ products, in particular C₇ and C₈ alkenes, were observed (Caeiro *et al.*, 2006; Guisnet *et al.*, 1992). Lukyanov *et al.* (1994) and (1995) carried out kinetic modelling of propene and propane aromatisation over H-ZSM-5 which include the rate constants estimation of various reaction steps. The alkenes formation (Fig. 2.9: step 1 and 2) was kinetically limiting and is 10³ times slower than diene formation step (Fig. 2.9: step 4), which is the slowest step of propene aromatisation. Diene formation is 10⁵ times slower than the fastest step, which is the aromatisation step (Fig. 2.9: step 7) and 10⁴-10⁵ times slower than oligomerisation-cracking (Fig. 2.9: step 3) and cyclic diolefin formation (Fig. 2.9: step 6) steps. As a result, the rate of aromatisation is highly dependent on the alkane reactant.

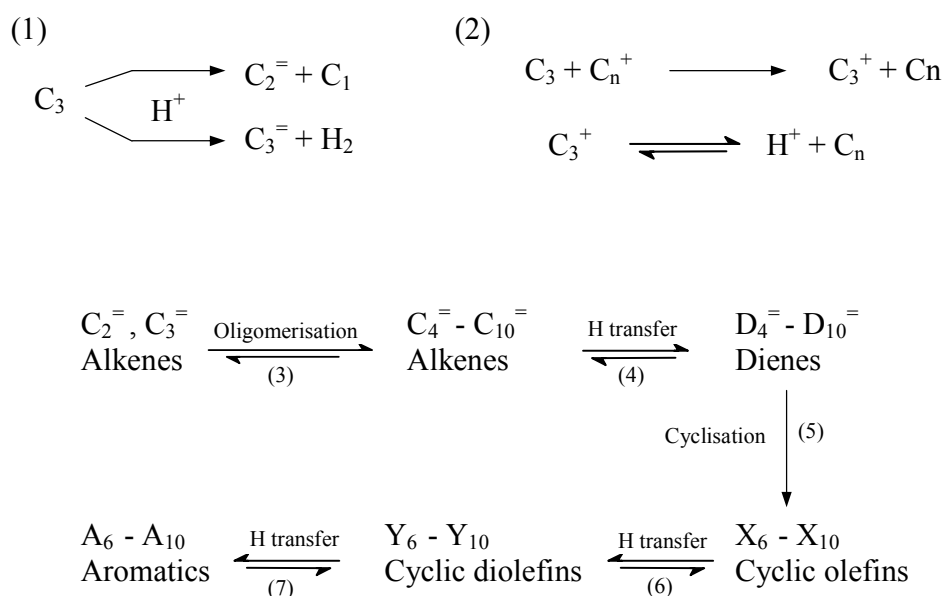

Figure 2.9. The reaction pathway of propane aromatisation over H-ZSM-5: Step (1) and (2) Alkane transformation into alkenes; Step (3)-(7) Alkene aromatisation (based on the papers by Caeiro *et al.*, 2006 and Lukyanov *et al.*, 1995).

Buckles and Hutchings (1996) pointed out that the major problem of the mechanistic study of the light alkane reactions is that the rates of secondary oligomerisation and aromatisation reactions are fast relative to the primary dehydrogenation of propane forming propene. This is in agreement with Raddi and Schmal (2000) stating that the dehydrogenation of light alkanes is the first and the rate limiting step of the light alkane aromatisation process. The rate of the limiting step could be increased by the incorporation of metal sites and Guisnet and Gnep (1992) had shown the positive effect of gallium on propane conversion.

It is generally agreed that the introduction of hydro/dehydrogenation components into acidic zeolite catalyst promotes the rate and selectivity of aromatisation of light alkanes. Caeiro *et al.* (2006) indicated that alkane transformation over bifunctional catalysts could proceed through a bifunctional reaction scheme, and is complex in terms of reaction scheme and catalyst system. Platinum (Pt), Palladium (Pd), Gallium (Ga) Zinc (Zn) and various bimetallic components are often chosen as the hydro/dehydrogenation species of the bifunctional zeolite catalysts (Guisnet and Gnep, 1992). The metal species has provided additional dehydrogenation routes for the alkane conversion into corresponding alkene and for the transformation of alkenes into aromatics and hydrogen (Nguyen *et al.*, 2006).

In light alkane aromatisation over H-ZSM-5, butane and isobutane react at similar rates, 4 times faster than propane and 100 times faster than ethane. The desired products, aromatics, are produced from secondary reactions and the incorporation of metal (gallium) species has greater positive effect on the alkane feed which is transformed slower on H-ZSM-5. The rate of ethane transformation over GaH-ZSM-5 is about 8 times higher than H-ZSM-5, while the rate of propane and butane transformation is about 4 and 1.2 times, respectively, higher. Additionally, the metal species affects the distribution of the primary products of light alkanes transformation, increasing the selectivity to dehydrogenation products and decreasing the cracking products. In propane aromatisation over PtH-ZSM-5, propene is the main primary product and the selectivity of propene increases with the platinum content. Additionally, alkenes side

products, such as ethene, are formed in small amounts, and the initial distribution of aromatic products is: 45 wt.% of toluene, 45 wt.% of C₈ aromatics and 10 wt.% of benzene on PtH-ZSM-5 against 50 wt.% of toluene, 25 wt.% of C₈ aromatics and 25 wt.% of benzene on H-ZSM-5 (Guisnet and Gnep, 1992).

2.2.2. Benzene alkylation with light alkanes: primary and secondary reaction steps

The benzene alkylation with light alkanes, such as ethane and propane, over a bifunctional catalyst, is a complex heterogeneous reaction that involves many individual reaction species and chemical reaction steps (Moreau *et al.*, 2002). As noted in the previous sections, the light alkanes could convert first into light alkenes, then the converted light alkenes could alkylate benzene forming alkybenzene (Bigey and Su, 2004; Kato *et al.*, 2001; Smirnov *et al.*, 2000). The alkylbenzene formed in the primary steps of benzene alkylation reaction could convert further by polyalkylation reactions, leading to the formation of polyalkylbenzene, and a number of side reactions, such as hydrogenolysis, transalkylation, disproportionation, etc (Degnan *et al.*, 2001 and Perego and Lngallina, 2002).

2.2.2.1. The primary steps of benzene alkylation reaction

The first step of direct benzene alkylation with light alkanes is the initial transformation of light alkanes forming light alkenes, followed by the benzene alkylation with the activated light alkenes formed in the light alkanes transformation steps (Fig. 2.2) (Bigey and Su, 2004; Kato *et al.*, 2001; Smirnov *et al.*, 2000). The initial transformation of light alkanes is described in detailed in section 2.2.1. Light alkanes could convert initially *via* dehydrogenation path forming equimolar amounts of alkene and hydrogen (Eq. 2.4) on the metal site, and *via* protolytic cracking reactions and hydride transfer on the acid sites forming various products, such as alkenes, hydrogen, lower alkanes and carbenium ions (Fig 2.6 and 2.7). The carbenium ions formed from both the cracking reactions of alkane and the protonation of alkene (resulting from alkane dehydrogenation over metal sites) can either alkylate benzene into alkylbenzenes,

or undergo consecutive transformations into aromatics (Caeiro *et al.*, 2006). The primary step of benzene alkylation reaction with ethane in EB is the alkylation of benzene with ethyl carbenium ions (Eq. 2.12).

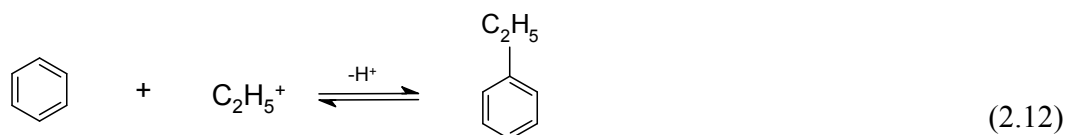

Additionally, Derouane *et al.* (2000) and Du *et al.* (2002) claimed that the benzene activation, i.e. benzene protonation forming benzenium ion, occurs when it adsorbs on strong acidic sites. The benzenium ion can abstract a hydride ion from the nearest alkane molecule forming alkyl carbenium ion and cyclohexadiene (Eq. 2.13). Eventually, the alkyl carbenium ion undergoes alkylation with benzene forming alkylbenzene (Eq. 2.12) (Caeiro *et al.*, 2006; Derouane *et al.*, 2000; Ivanova *et al.*, 1996).

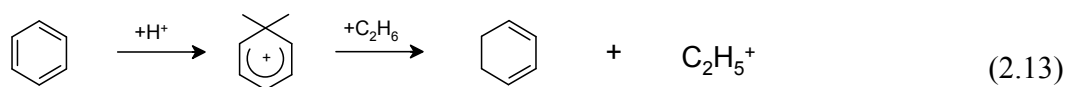

Smirnov *et al.* (2000) proposed the direct benzene alkylation with propane over the bifunctional catalysts. The metal and acid sites of the bifunctional catalyst, when positioned in close proximity, might form a metal-acidic center (Bhasin *et al.*, 2001; Smirnov *et al.*, 2000). The overall conversion and selectivity to desired product significantly increased on Pt/H-ZSM-5 bifunctional catalyst than on a physical mixture of Pt/CeO₂ and H-ZSM-5 catalyst. This suggests that the mean distance between the Pt and the acid site is important; the shorter the distance, the more active and selective is the catalyst. Hence, the benzene alkylation with propane over Pt/H-ZSM-5 bifunctional catalyst could proceed through the metal-acidic center, i.e. without the desorbed intermediate. In this case, propane dehydrogenation and protonation may take place on the metal-acidic center resulting in the direct benzene alkylation (Eq. 2.14) (Smirnov *et al.*, 2000).

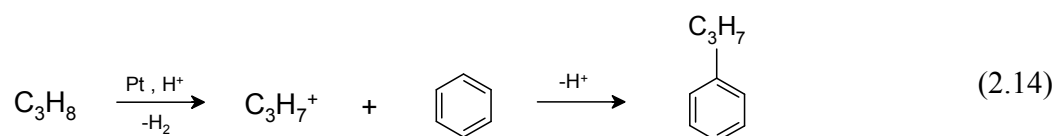

On the other hand, the benzene alkylation with propane over a physical mixture of Pt/CeO₂ and H-ZSM-5 catalyst could involve the desorbed intermediate. The propane activation preferentially occurs on the metal site, *via* dehydrogenation reaction forming propene. Propene is further protonated on acid sites producing carbenium ions which can alkylate benzene forming propylbenzenes (Eq. 2.15) (Smirnov *et al.*, 2000).

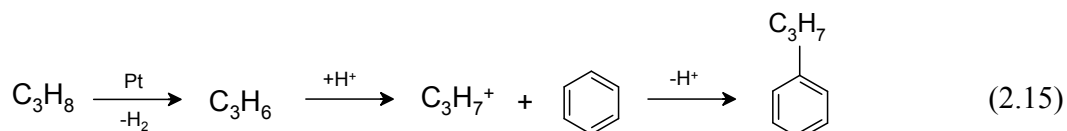

On pure acidic catalyst, such as H-ZSM-5 catalyst, propane activation is dominated by protolytic cracking and hydrogen transfer leading to a variety of carbenium ions, such as propyl-, ethyl-, methylcarbenium ions. These carbenium ions further alkylate benzene forming propylbenzenes, ethylbenzene and toluene, hence, leading to very low propylbenzene selectivity (Fig. 2.10) (Smirnov *et al.*, 2000).

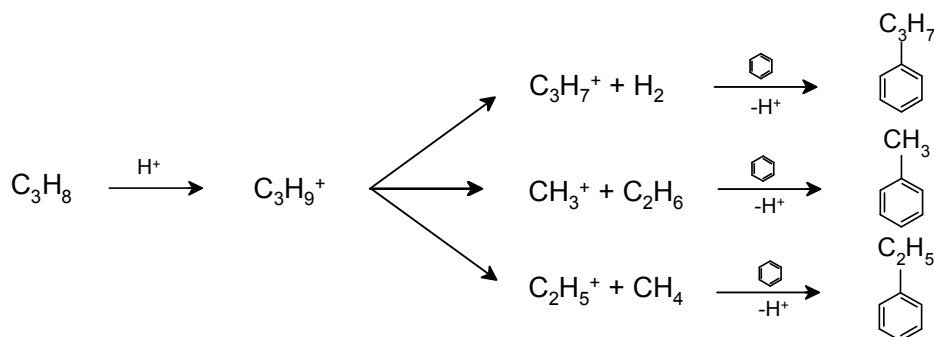
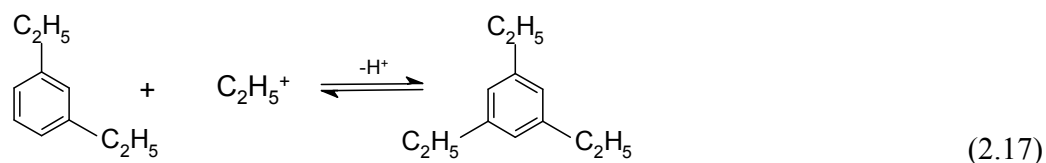
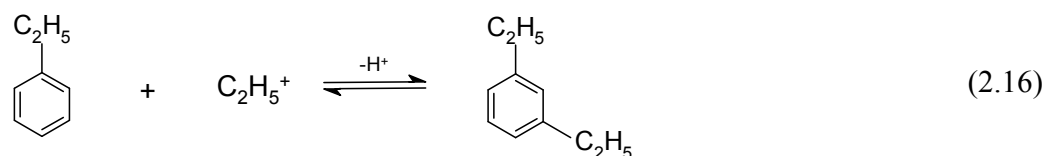

Figure 2.10. Primary reaction steps of benzene alkylation with propane over H-ZSM-5 catalyst (based on Smirnov *et al.*, 2000).

2.2.2.2. The secondary steps of benzene alkylation reaction

In benzene alkylation with ethane over bifunctional catalyst, EB is initially formed in the primary step and the EB formed could be converted further by secondary reaction steps. The EB reacts with ethyl carbenium ions *via* polyalkylation reactions, forming DEBs and TEBs (Eq. 2.16 and 2.17) (Perego and Lngallina, 2002). The DEBs and TEBs

could be recycled by combining with the fresh and recycled benzene and fed, together with fresh ethene, to an alkylation reactor (Degnan *et al.*, 2001).



The product distribution of DEB isomers in the reactions over ZSM5 zeolites catalysts is affected by the thermodynamic equilibrium, geometrical restrictions as well as the diffusional limitation, i.e. the differences in the diffusivities of various product molecules (Schumacher and Karge, 1999). Generally, the fraction of para-isomer is expected to be enhanced while the ortho isomer would be suppressed, since the formation of the smaller m/p-diethylbenzenes in the shape selective ZSM5 zeolite catalyst is more favourable compared to the formation of bulkier o-diethylbenzene. The distributions of DEB isomers is also affected by thermodynamic equilibrium (Kaeding, 1985). Table 2.2 shows the thermodynamic equilibrium of DEB isomers at different temperatures.

Table 2.2. Thermodynamic equilibrium of DEB isomers (Kaeding, 1985).

Temperature ($^{\circ}\text{C}$)	p-DEB (%)	m-DEB (%)	o-DEB (%)
100	33.2	54.7	12.1
200	31.3	53.7	15.0
300	29.8	52.7	17.5
400	28.5	52.0	19.5
500	27.5	51.3	21.2
600	26.7	50.7	22.6

Schumacher and Karge (1999) pointed out that the diffusivity of para isomer in ZSM5 zeolite catalyst is of the same magnitude as those reported for monosubstituted benzenes and benzene. Owing to the large differences of the transport velocities of isomers, the para isomer produced primarily inside the zeolite diffuses much faster to the external surface than the other disubstituted isomers. As a result, the selectivity towards the para isomer will be generally enhanced compared to other disubstituted isomers produced in subsequent isomerisation reactions.

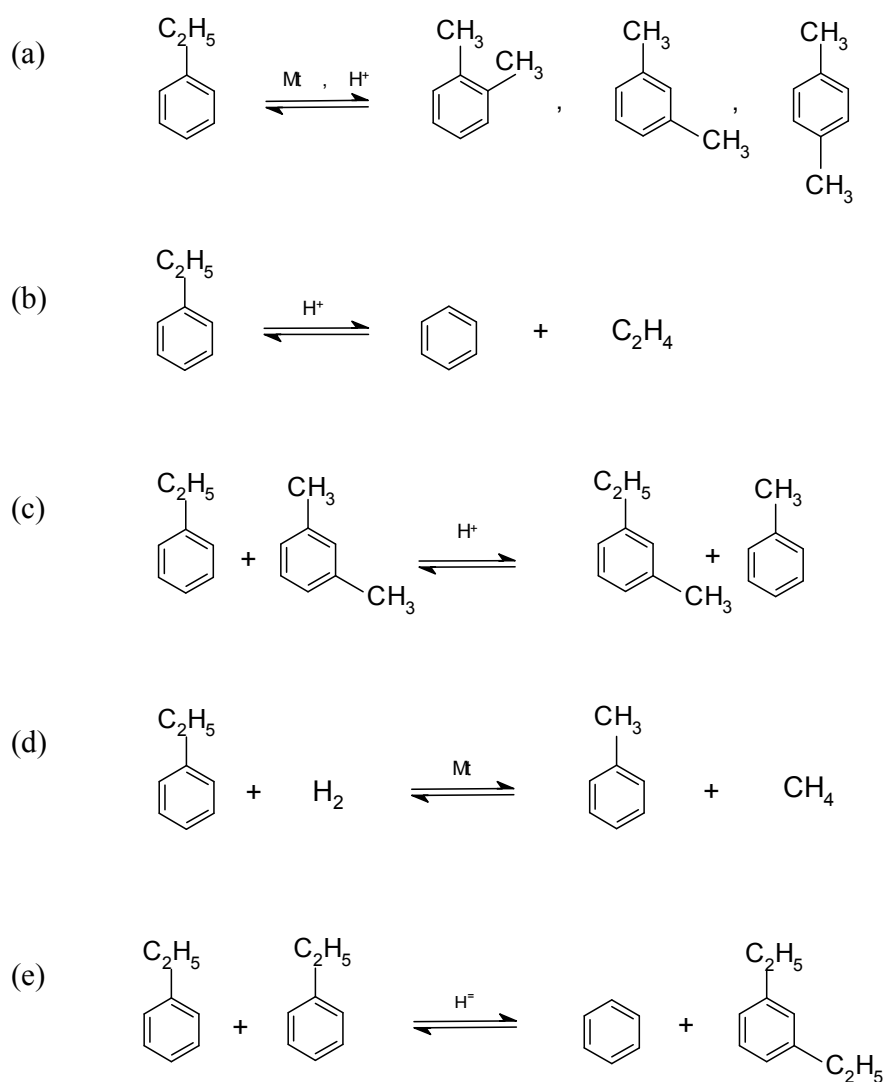

Figure 2.11. Main reactions of ethylbenzene over bifunctional catalysts: (a) isomerisation; (b) dealkylation; (c) transalkylation; (d) hydrogenolysis; (e) disproportionation (based on paper by Moreau *et al.*, 2002).

The EB formed from the primary step could be transformed *via* five main reactions: the isomerisation of EB into xylene isomers (Fig 2.11a); the dealkylation of EB forming benzene and ethene (Fig 2.11b); the transalkylation of EB and xylene forming ethyltoluene and toluene, or dimethylethylbenzene and benzene (Fig 2.11c); the hydrogenolysis of EB producing toluene and methane (Fig 2.11d); and the disproportionation of EB which leads to the formation of benzene and DEBs (Fig 2.11e) (Moreau *et al.*, 2002). Caeiro *et al.* (2006) highlighted that benzene alkylation is thermodynamically limited and the dealkylation reaction (reverse step) contributes to the high alkane conversion, by forming significant amount of alkene that can be eventually transformed into aromatics.

In the isomerisation reaction over bifunctional catalyst (Fig 2.11a), EB first converts, in the presence of hydrogen, to hydrogenated intermediates on metal sites. It is followed by the isomerisation of the hydrogenated intermediates on acid sites, and finally, the dehydrogenation of the isomerised intermediates occurs on metal sites and forms meta-, para-, and ortho-xylene isomers (Fig. 2.12). Additionally, the methyl group of the xylene isomers could migrate directly around the aromatic ring (Fig. 2.13) (Olson and Haag, 1984) and the formation of smaller m- and p-xylene isomers is favoured over the formation of slightly larger isomer, o-xylene, in the shape selective zeolite-based catalysts (Sealy and Traa, 2005).

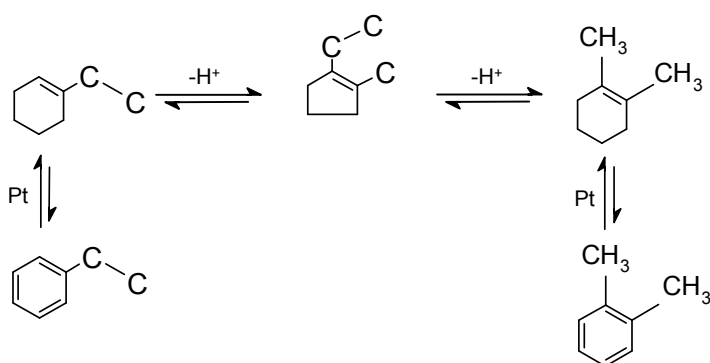

Figure 2.12. Ethylbenzene isomerisation over bifunctional catalyst with hydrogenated intermediates (based on Olson and Haag, 1984).

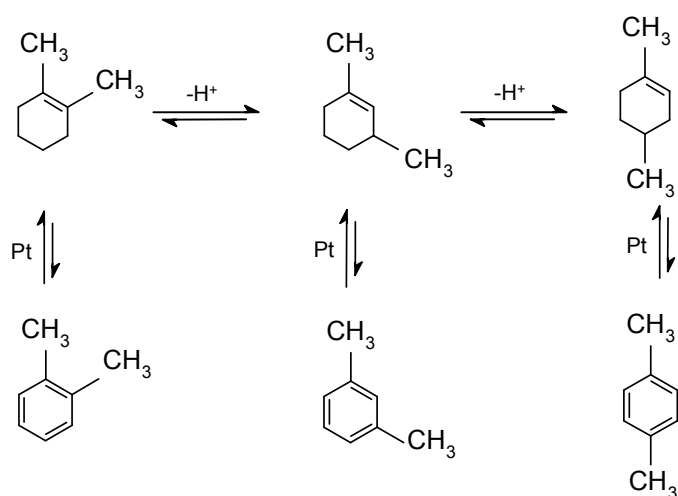

Figure 2.13. Xylenes isomerisation: direct methyl migration around xylene aromatic rings (based on Olson and Haag, 1984).

Ivanova *et al.* (2006) suggested that the disproportionation and the transalkylation steps occur simultaneously. Three mechanisms are proposed in the literature for the transalkylation and disproportionation of alkylbenzenes. One of the proposed mechanisms is the direct shifting of the alkyl group from one aromatic ring to another without intermediate formation of an alkyl carbenium ion. The second proposed mechanism involves the formation of alkyl carbenium ions as intermediates. In the monomolecular mechanism, the alkyl group on the alkylbenzene undergoes C-C bond cleavage on acid site forming alkyl carbenium ion and benzene. The alkyl carbenium ion formed in the primary step alkylates another alkylbenzene producing dialkylbenzene (Fig. 2.14a). The third suggested mechanism involves bimolecular intermediates, where the aromatic rings are bridged by a carbon atom from the alkyl group. The bimolecular intermediates would eventually dissociate into dialkylbenzene and benzene (Fig. 2.14b) (Ivanova *et al.*, 2006; Santilli, 1986; Tsai and Wang, 1992). Santilli (1986) highlighted that if the alkyl group of the reactant is small, the bimolecular mechanism would appear to be the lower energy process due to resonance stabilisation of the carbonium ion intermediate. However, the carbonium ion intermediate is large and therefore, its formation may be hindered in catalysts with small pore size, such as ZSM-5.

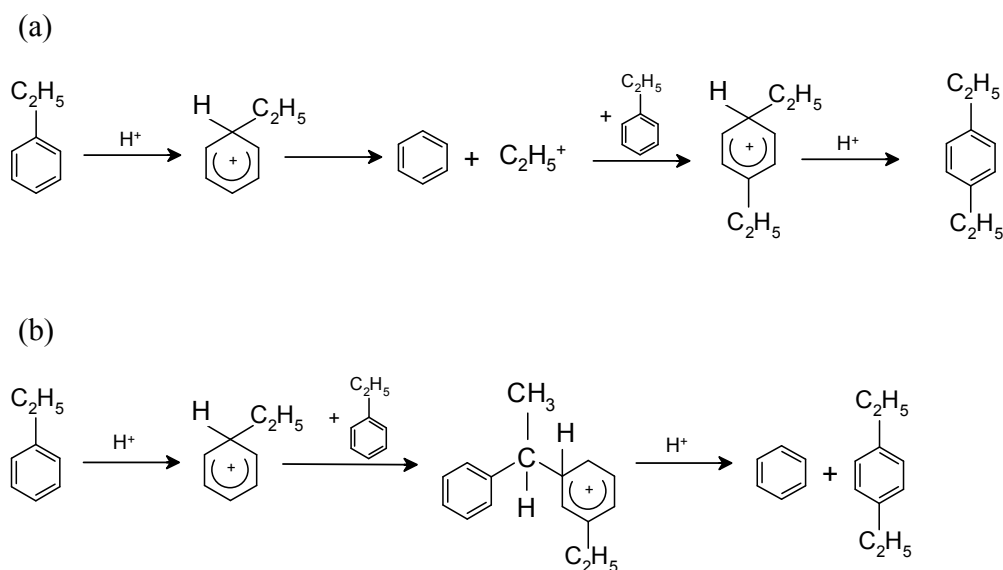

Figure 2.14. Disproportionation and transalkylation reactions of ethylbenzene: (a) molecular mechanism, (b) bimolecular mechanism (based on Ivanova *et al.*, 2006; Santilli, 1986; Tsai and Wang, 1992).

In conclusion, the light alkanes are converted first *via* dehydrogenation, protolytic cracking and hydrogenolysis reactions into light alkenes. These light alkenes either alkylate benzene forming alkylbenzenes, or they undergo oligomerisation, cracking, hydrogen transfer and aromatisation reactions forming aromatics. In the dehydrogenation reaction, light alkanes are activated initially on the catalyst metal sites. Then, the activated light alkanes form intermediates and react further on the catalyst acid sites forming light alkenes. On the other hand, the cracking reactions take place only on the acid sites. The light alkanes are protonated on the Brønsted acid sites present in the catalysts forming the unstable carbonium ions, and these carbonium ions convert further to alkenes, lower alkanes and hydrogen over the acid sites. Additionally, it is proposed that the hydrogenolysis of light alkanes is structural sensitive reaction which takes place on the metal sites of the bifunctional catalysts. In the aromatisation reactions, light alkenes undergo rapid acid-catalysed chain growth reactions, on acid sites, and form aromatic products. The protonated carbenium ions alkylate benzene into alkylbenzenes over the strong acidic sites, and the alkylbenzene produced in the primary reaction step

would alkylate further by carbenium ions *via* polyalkylation reactions forming polyalkylbenzenes. The benzene alkylation with alkanes is accompanied by a series of side reactions, i.e. isomerisation, transalkylation, disproportionation, dealkylation, hydrogenolysis, etc., leading to the formation of various side products. The transalkylation, disproportionation and dealkylation reactions take place on the acid sites present in the bifunctional catalysts, while the EB isomerisation reaction requires both metal and acid sites. These side products favour the coke formation, and eventually suppress the formation of desired products.

It appears that some controversy still exists regarding the detailed mechanism of the benzene alkylation with light alkanes. The understanding of the reaction pathways and the role of the metal and acid sites in different reaction steps would lead to better understanding of the catalyst performance. This would eventually lead to development of better catalysts and hence, improve the feed conversion, product selectivities, yield, etc.

2.3. Catalysts for benzene alkylation with light alkanes

Catalysts act by chemisorbing one or more of the reactants, and the consequent perturbation of the electronic and geometric structure of the molecule lead to the enhancement in the rate of reaction. The maximum catalytic activity is expected to be achieved by the catalyst with intermediate strength of chemisorption, which allows the modification of the reactant molecules for its reactivity to be greatly affected but prevents the formation of stable compound that will cover the catalyst surface (Kubicka *et al.*, 2006).

An effective catalyst for benzene alkylation with ethane into EB should enhance the desired reaction steps: (i) ethane dehydrogenation into ethene and hydrogen, and (ii) benzene alkylation with ethene forming EB, and suppress the possible side reactions. Lukyanov and Vazhnova (2008a) has categorised the side reactions into three groups: (i) hydrogenolysis (hydrocracking) of ethane into two methane molecules; (ii) alkene oligomerisation and cracking reactions forming other alkenes which could alkylate

benzene into various alkylbenzene and, possibly undergo aromatisation reactions; (iii) transformation of EB *via* a number of secondary reactions, such as hydrogenolysis, further alkylation with alkenes, dealkylation, isomerisation, etc. The selectivity of benzene alkylation with ethane into EB could increase by limiting the rates of these side reactions.

A number of publications pointed out that in benzene alkylation with light alkanes, the dehydrogenation of light alkane into light alkene is catalysed by the metal species while the benzene alkylation reaction carries out on the acid catalyst (Abdul Hamid *et al.*, 1996; Krogh *et al.*, 2003; Lukyanov and Vazhnova, 2008a). As a result, the acid supported metal bifunctional catalysts, which consists of two types of distinct catalytic sites: metal site and acid site, would be appropriate for the benzene alkylation with light alkanes. Reschetilowski *et al.* (2001) illustrated that Group VIII metals such as platinum (Pt), palladium (Pd), nickel (Ni) and ruthenium (Ru), or metal cations such as gallium (Ga) and Zinc (Zn) are effective dehydrogenation components. Kuhlmann *et al.* (2004) pointed out that zeolites and alumino-silicate are the most suitable acidic supporting materials for metals. Among the zeolites, the best results for benzene alkylation with light alkanes being always obtained with the tri-dimensional medium pore ZSM-5 zeolite. Larger pore size zeolites such as FAU and MOR and average pore size zeolites with micropores smaller than those of ZSM-5 gave low conversion and/or poor selectivity (Caeiro *et al.*, 2006).

The metal incorporation techniques, such as wetness impregnation and ion exchange, and the catalyst preparation steps, such as drying and calcination, are believed to have significant influence on the final metal distribution and the properties of the active metal (Canizares *et al.*, 2001). Additionally, Kuhlmann *et al.* (2004) pointed out that the incorporation of noble metals (Pt, Pd, Ru) strongly affects the acidity and hence the activity of the catalyst. The incorporation of metal on zeolite supports may modify the Brønsted acid sites as well as the metal state, which may eventually lead to significant changes on the acid and metal site density and strength distribution. At the same time, the acidic support that has the catalytic function is affecting the dispersion of

metals, the adsorption phenomena and the mechanism of the reactions (Stiles, 1987). As a result, the proper balance between the acid and metal sites is critical in determining the most optimum catalyst in terms of the reactivity, stability and selectivity (Romero *et al.*, 1996).

2.3.1. Bifunctional catalysts: the support

Metal supported bifunctional catalysts play a significant role in heterogeneous catalysis and are used widely in industry, in for example dehydro/hydrogenation, hydrogenolysis, and hydroisomerisation reactions (Kuhlmann *et al.*, 2004). The efficiency of a heterogeneous catalysis process is greatly determined by the exposed surface area of active phase. The correlation between the specific surface area and the particle size shows that reasonable surface areas are obtained at low values of particle sizes (1-10nm). Hence, it would be necessary to apply support bodies on the metal nanoparticles, thus the catalysts would be in reasonable size to be placed in reactors (Anderson and Garcia, 2005). The metal particles are distributed on a support which retains the metallic particles in a state that is stable towards agglomeration and is accessible to reactant (Anderson, 1975). There is a wide range of possible support materials as the supported metallic catalysts are used under wide range of conditions (Anderson, 1975). Zeolites, Silica (SiO_2) and alumina (Al_2O_3) are the most common support materials for bifunctional catalysts involved in light alkanes transformation (Kuhlmann *et al.*, 2004; Lukyanov and Vazhnova, 2007; Smirnov *et al.*, 2000).

2.3.1.1. Zeolites

Zeolites, also known as molecular sieves, were first discovered by a Swedish mineralogist (Cronstedt, in 1756) but were introduced as a catalyst only in 1959 in isomerisation reaction (Dyer, 1988). Zeolites become one of the most important catalysts in hydrocarbon reactions over the past 50 years due to their shape selective and environmentally friendly properties. They are well-defined microporous crystalline naturally occurring aluminosilicate minerals with a three-dimensional framework built up by SiO_4 and AlO_4 tetrahedra. These tetrahedrals are structured such that the oxygen at each tetrahedral corner is shared with an identical tetrahedron (Si or Al). The channels

and cavities, which contain water molecules along with cations, are necessary to balance the charge of the framework (Dyer, 1988; Ullmann's, 1996a).

The general formula for a zeolite is:

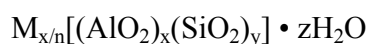

where M is the non-framework metal ion, n is the valence of cation M, x and y are integers with $y/x \geq 1$, z is the number of water molecules in each unit cell (Ullmann's, 1996b).

Zeolites are widely involved in conventional chemical reactions because of their unique properties. Zeolites are highly well structured, which give high products selectivity, and are extremely thermally stable, that can be operated at moderate temperature (250 – 300°C) (Macquarrie, 2000; Perot and Guisnet, 1990). Zeolites are used as catalysts in various complex hydrocarbon transformations because their acid-base properties can be modified during their synthesis, or by post-synthesis treatments (Perot and Guisnet, 1990). They have great adaptability and can function as carriers of redox components in well-dispersed form (Perot and Guisnet, 1990). Highly-silica zeolites such as ZSM-5 are attractive catalysts for many industrial processes because of their shape selective, well-defined pore structure, hydrothermal and acidic stability, high activity, and temperature and coke resistance properties (Guczi and Bazin, 1999, Jao *et al.*, 1996, Reschetilowski *et al.*, 1991; Smirniotis and Ruchenstein, 1993).

On the other hand, the well-defined pore structure of zeolites limits the size of synthesized molecules; hence the formation of large molecules *via* zeolite-based catalysts is not favourable. Moreover, zeolites are highly sensitive to the deactivation caused by coking. The access of the reactant to the active sites in zeolites can be blocked even by small amount of coke (Perot and Guisnet, 1990).

The performance of zeolites in the synthesis of hydrocarbons within the zeolite framework structures depends on the shape selectivity effects and the strong Brønsted

acidity of bridging Si-(OH)-Al sites generated by the presence of aluminum inside the silicate framework (Armaroli *et al.*, 2006; Dimitrova *et al.*, 2006). The shape selective properties of zeolite catalysts allow molecules with critical kinetic diameter lower than the channel diameter to enter the pores, to react on the acid sites or, to exit the channels, and to be recovered as the products of the reactions (Armaroli *et al.*, 2006). Zeolites with pores less than 2 nm are categorised as highly structured microporous inorganic solids (Macquarrie, 2000). The acid strength of the zeolite is strongly connected to the Brønsted acid sites, i.e. catalyst protonation ability and bridging hydroxyl groups. Many researchers have proved that the acid strength of the zeolite is inversely proportional to the aluminum (Al) content (Guczi and Bazin, 1999, Jao *et al.*, 1996, Reschetilowski *et al.*, 1991; Smirniotis and Ruchenstein, 1993). It was shown that each type of zeolites would approach the optimum acidity at a specific Al content (Dimitrova *et al.*, 2006). On the other hand, 'real' zeolite catalysts are usually pre-treated in various ways and have imperfect crystalline structure, such as the extra-framework aluminum sites. The presences of these sites are common and they either act as active sites or as sites that hinder the molecular diffusion (Armaroli *et al.*, 2006). It is mentioned above, that the activity of the zeolite acid catalysts is strongly affected by the catalyst framework and the acid strength. Hence, the characterisation of zeolite catalysts has been mainly focused on the chemical properties, such as catalyst acidity, and the physical properties, such as zeolite pore size, of the zeolites.

ZSM-5 zeolite is widely applied in industrial scale production of alkylbenzene, xylene and toluene (Trombetta, 2000). Additionally, Corma *et al.* (2000) claimed that ZSM5 is one of the best catalysts for the production of EB *via* gas phase benzene alkylation with ethene. ZSM5 is medium-pore, 10-membered rings zeolite (Trombetta, 2000). Figure 2.15 shows the pore structure of ZSM5. The pore structure of ZSM5 consists of one vertical channel with elliptical shape ($5.1\text{\AA} \times 5.6\text{\AA}$) interconnected with another, sinusoidal near-circular channel ($5.4\text{\AA} \times 5.6\text{\AA}$) (Dyer, 1988; Macquarrie, 2000). These pore structures form the unique shape-selective properties of ZSM5. For example, the pores of ZSM5 are extremely efficient and selective to the diffusion and desorption

of para-disubstituted benzenes such as para-xylene with respect to other isomers (Trombetta, 2000).

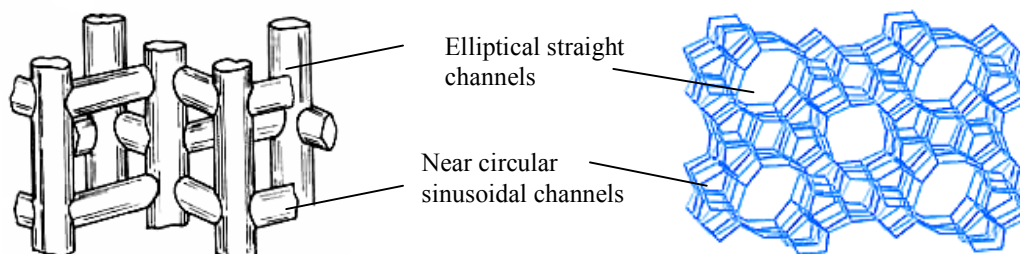

Figure 2.15. The channels and framework of ZSM5 zeolite (Macquarrie, 2000).

The activity of zeolites is determined by the presence of Brønsted acid sites, which originate from the creation of hydroxyls within the zeolite pore structure. Hydroxyls are formed by ammonium or polyvalent cation exchange or direct exchange with mineral acid for high-silica zeolites (Perot and Guisnet, 1990). Hydroxyls are protons associated with negatively charged framework oxygens associated with alumina tetrahedral, as shown in Figure 2.16 below.

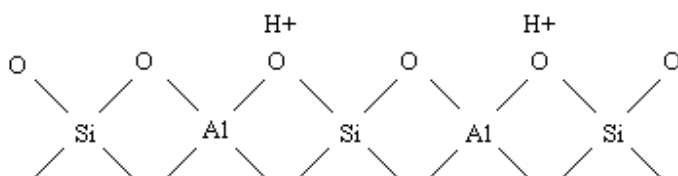

Figure 2.16. Brønsted acid sites in zeolites.

Dyer (1988) illustrated that great mobility of protons are observed when the temperatures exceeded 200°C and at 550°C these protons are lost as water forming Lewis acid sites. Figure 2.17. illustrates this step.

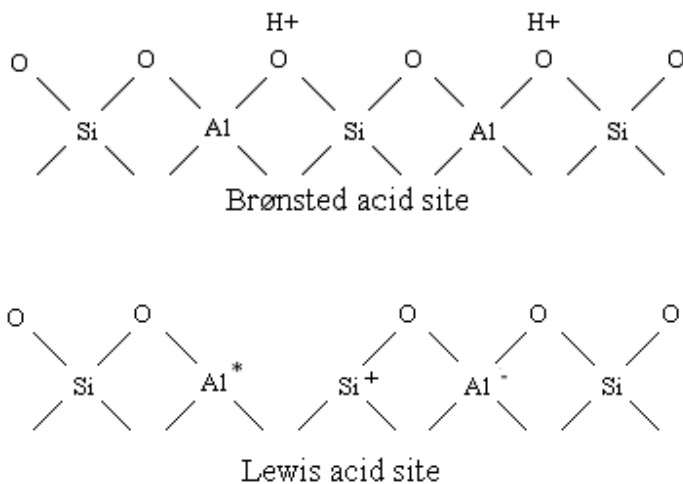

Figure 2.17. Conversion of Brønsted acid sites to Lewis acid sites.

The Lewis acid sites are unstable in the presence of water vapour and they need an annealing process to stabilize the structure. These Lewis sites will expel Al species from the framework and form *true* Lewis sites. The Lewis sites in zeolites may exist in the form of threefold coordinated Al and/or the *true* Lewis sites which is the extra-framework Al-containing species such as AlO^+ . This is shown in Figure 2.18.

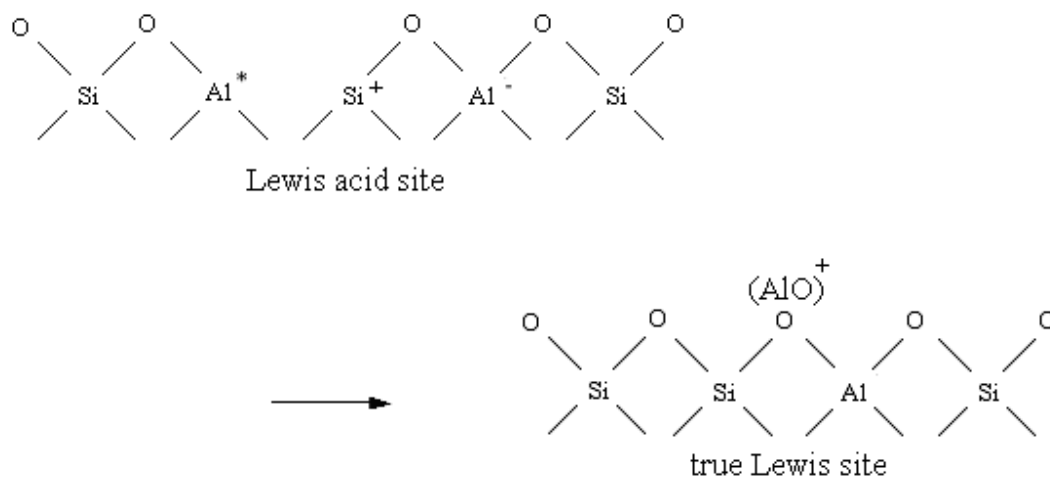

Figure 2.18. Transformation of Lewis site to the *true* Lewis site.

Dyer (1988) suggested that the Lewis activity is performed by $(\text{AlO})^+$ species while the tricoordinated Al of the Lewis site (Al^*) is considered as a weak acid. Zeolites are unique catalysts for catalytic cracking processes because of the high stability of the particles and this ability to form *superacid* sites by the interaction between Brønsted and Lewis sites (Dyer, 1988).

The catalytic active sites exist in the pores, on the external surface and at the pore mouth of the zeolite crystals. The active sites in the pores are responsible for the formation of desired reaction products, while, the sites on the external surface and at the pore mouth may favour the formation of the unwanted non-selective catalysis. The unwanted non-selective reactivity could be avoided by limiting the external surface and the extra-framework material, by producing large well crystallised zeolite crystals (Armaroli, *et al.*, 2006).

2.3.2. Bifunctional catalysts: the metal

The incorporation of metal into zeolite has led to the bifunctional reaction pathways for the conversions of hydrocarbons, as discussed in section 2.2. The metal improves the catalytic stability of the acidic zeolites by suppressing the formation of carbonaceous deposits blocking the zeolite pores and acid sites. On the other hand, the presence of metal affects the acidic properties of the supports by reducing the strength of the acid sites which is evidenced in the changes of the desorption of pyridine by the acid sites (Kubicka *et al.*, 2006).

The transition metals especially the group VIII metals such as platinum (Pt), palladium (Pd), nickel (Ni) and ruthenium (Ru), are proved to be the active metal catalysts (Anderson, 1975; Reschetilowski *et al.*, 2001). The most common Pt precursors are chloroplatinic acid (H_2PtCl_6) and platinum (II) tetramine ion, $[\text{Pt}(\text{NH}_3)_4]^{2+}$ while other cationic complexes such as $[\text{Pd}(\text{NH}_3)_4]^{2+}$, $[\text{Ru}(\text{NH}_3)_6]^{3+}$, $[\text{Ru}(\text{NH}_3)_4(\text{NO})(\text{OH})]^{2+}$, etc. are also used as the metal precursor (Anderson, 1975).

Metal is introduced to the support, usually from precursor solution, by processes such as impregnation, ion exchange, or co-precipitation, followed by drying, calcination (high temperature treatment) and hydrogen reduction. During calcination, the metal compounds on the support decompose, and in order to obtain the maximum degree of metal dispersion, the metals compounds should be chosen such that decomposition and reduction occur at low temperatures (Anderson, 1975).

The catalyst preparation procedures and metal precursor would affect the properties of the metal particles, such as the metal particle size and metal dispersion, and hence, the activity and the selectivity of the bifunctional catalysts. A finely divided solid usually consists of particles the size of which spans a range of values and this is known as the particle size distribution (Fig. 2.19). The mode line passes through the peak of the distribution curve, the median line divides the area under the curve into equal parts, and the mean (Eq. 2.18) is the point on the diameter scale the deviations from which sum to zero, i.e. $\sum_i f_i (d_i - \bar{d}) = 0$ (Anderson, 1975).

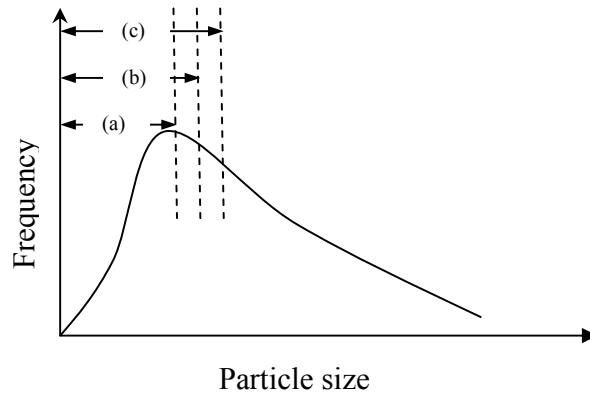

Figure 2.19. Schematic metal particle size distribution indicating three common measures of central tendency: (a) mode, (b) median, and (c) mean (Anderson, 1975).

$$\bar{d} = \frac{\sum_i f_i d_i}{\sum_i f_i} \quad (2.18)$$

where f is the frequency, d is the particle diameter.

The metal particles in a supported catalyst can be observed and measured directly by using electron microscopy, X-ray method and magnetic measurements. The scanning electron microscopy (SEM) is one of the most commonly used techniques in the estimation of particle size but its effectiveness is restricted to particles larger than about 100 nm. The X-ray diffraction line broadens when the crystallite size falls below about 100 nm. The technique is particularly applicable to metal crystallites of size 3-50 nm; below 3 nm the line is so broad and diffuses as to become lost while above about 50 nm the change in peak shape is small leading to insensitivity. Small angle x-ray scattering (SAXS) is capable of estimating metal particle size in the range of 1-100nm. This technique uses information contained in radiation scattered within a few degrees ($<5^\circ$) of the primary beam (Anderson, 1975).

The metal loading of supported metal catalysts is often assumed to be equal to the designed or nominal value. However, Lambert and Gonzalez (1998) highlighted that there is often a discrepancy between the designed metal loading and the actual metal loading of the final catalyst regardless of the catalyst preparation methods. The difference between the designed and actual metal loading could be due to the losses of metal species during catalyst preparation, drying, or pre-treatment. The analysis of the actual metal loading could be determined by inductively coupled plasma (ICP), or atomic absorption (AA). The discrepancy of catalysts prepared by ion-exchange is related to the practice of washing the catalyst to elute weakly absorbed metal precursors while the impregnated catalysts, which were not washed, were most likely to lose the weakly absorbed precursors during the catalyst pre-treatment (Lambert and Gonzalez, 1998).

The dispersion measurement of the supported metal is defined as the ratio of the number of surface metal atoms (N_s) to the total number of metal atoms (N_t) within the system (Eq. 2.19).

$$D = \frac{N_s}{N_t} \quad (2.19)$$

Generally, the dispersion measurement can be obtained either by chemical methods, where the amount of gas (such as CO, O₂ or H₂) required to complete monolayer coverage is determined, or by physical methods, where the average particle size is found from the surface/bulk ratio by making an assumption regarding particle shape. Both methods provide information on the metal surface area which allow the comparison of a series of catalysts on a per site or unit area basis rather than a per gram of metal basis, i.e. the more appropriate method of comparison. The chemisorption methods provide a surface average crystalline size *via* adsorbate-surface metal atom interaction. It is assumed that all surface metal atoms are free from other adsorbates such as coke and other poisons, the surface metal species are all in an appropriate oxidation state (usually zero) and that the adsorption stoichiometry is known and is independent of crystalline size (Anderson, 1975; Anderson and Garcia, 2005).

2.3.3. Pt supported bifunctional catalyst

Stiles (1987) highlighted significant research and development efforts on platinum reforming catalysts in early 1950s and these researches had provided the fundamental understanding for future catalyst development. However, various problems were encountered in the study of the structure and catalytic properties of supported metal catalysts. The three most significant problems are: (i) the sintering mechanism of supported metal catalysts; (ii) the structure of small metal crystals, and their catalytic properties; (iii) catalysis by metal clusters (Slinkin, 1980). These problems could be resolved, and hence enhancing the catalytic activity of the bifunctional catalysts if clear information on the metal particle's structure, such as the particle size and shape, and the metal dispersion, etc. is available.

The main purpose of using the support materials is to maintain the dispersion of metal particles, but large amount of studies have shown that the support modifies significantly the catalytic properties of the metal particles (Treesukol *et al.*, 2005). The interaction between the Pt and the support are mutual; the support affects the properties of the Pt and at the same time, the properties of the support are influenced by the Pt. A small decrease in the specific surface area of catalysts was observed after their

impregnation with Pt, which could be possibly due to the blockage of some of the micropores. Kubicka *et al.* (2006) showed that the electronic properties of Pt are altered by the support and the extent of this alteration is depended on the acidity of the support, i.e., Pt-H bond (metal-support interaction) is stronger in the more acidic catalyst. Nevertheless, the incorporation of Pt modifies the strength of the acid sites. The total concentration of BAS and LAS remains unchanged or increases while the strongest acid sites, i.e., those that can retain pyridine at temperatures higher than 450°C, were completely disappeared when the H-zeolite are impregnated with Pt. The rise of the concentration of LAS is most likely due to the interaction of pyridine with Pt crystallites, given that the metal crystallites are known to be acceptors of electron pairs, i.e., to act as Lewis acids.

2.3.3.1. PtH-ZSM-5

Zeolite-supported platinum is a very active and stable catalyst for hydrocracking, hydroisomerisation, and reforming of hydrocarbons (Treesukol *et al.*, 2005). The incorporation of Pt particles in zeolite can be divided into three steps: introduction of the platinum, pre-treatment (calcination, when conducted in an oxygen-containing atmosphere at high temperature), and reduction. The introduction of Pt to zeolite supports is based on the exchange Na^+ or H^+ ion for positively charged Pt complexes, such as $[\text{Pt}(\text{NH}_3)_4]^{2+}$ (Anderson, 1975; Van den Broek *et al.*, 1997). The pre-treatment processes, such as hydrogen reduction, influenced greatly the location and size of the metal particles (Van den Broek *et al.*, 1997).

The formation of metal particles started with the deposition of metal as a single isolated atom, which is stabilised on the support. Then, at low coverage, i.e. low metal loading, and low reduction temperature (<300°C), the isolated metal atoms coalesce into two-dimensional islands, which may be one-atom thick or multilayer. Further increase in the metal loading, or/and reduction temperature would led to the formation of three-dimensional metal crystallites (Stakheev and Kustov, 1999). Anderson (1975) and Shpiro *et al.* (1991) showed similar results that with all supported catalyst, the average metal particle size increases with the metal loading, and illustrated further that the

particle size also depends on other factors such as the nature of the support, particularly the pore structure. The high stability of metal supported zeolite catalyst is due to the zeolite framework, where the channels and the supercages are able to prevent the formation of large metal particles on the surface of the zeolite (Guczi and Bazin, 1999, Jao *et al.*, 1996, Reschetilowski *et al.*, 1991; Smirniotis and Ruchenstein, 1993). In type ZSM zeolites, where the pore size is 5.5-6 Å, the most likely reaction site would be the pore mouths of a zeolites catalyst. Bragin *et al.* (1986) suggested that the catalysis takes place on the fraction of Pt dispersed to a crystallite size of about 10 Å that is dispersed in the pore mouths. These are probably the active centres for the dehydrogenation of ethane into ethene. The ethene could then penetrate into the zeolites pores, undergoes further conversion into oligomers and aromatics.

Two active centers of the PtH-ZSM-5 i.e. the metal particle and the acid site, may work collaboratively as the bifunctional catalyst (Treesukol *et al.*, 2005). It is important to maintain the right balance between dehydrogenating and acidic functions of the bifunctional catalyst as these functions determine the reactivity and selectivity of bifunctional catalysts, as noted above (Caeiro *et al.*, 2006; Canizares *et al.*, 2001). Additionally, due to the high cost of platinum, it is of strong economic incentive to minimise the amount of Pt used in the preparation of the supported catalysts, i.e. achieving high Pt dispersion in order to expose as much of the Pt sites as possible to the reactants (M'Kombe *et al.*, 1997). Caeiro *et al.* (2006) pointed out that the balance of the active centers of bifunctional catalyst is commonly known as the ratio between the concentrations of accessible Pt and protonic sites (n_{Pt}/n_A). M'Kombe *et al.* (1997) carried out TEM and CO chemisorption analysis on PtH-ZSM-5 catalysts and showed that the catalyst that has the lowest platinum loading (0.75wt.%) among the analysed catalysts (1.55wt.%) exhibits highest platinum dispersion.

Caeiro *et al.* (2006) proved that the n-butane dehydroisomerisation reaction catalysed by 0.5wt.% PtH-ZSM-5(240) catalyst has highest value of n_{Pt}/n_A among the catalysts analysed and yielded highest amount of isobutene. Canizares *et al.* (2001) and Jao *et al.* (1996) agreed that if the metallic sites of the catalysts are present in sufficient

excess, the rate-limiting step of the reaction could be the reaction on the acid sites and *vice versa*. Canizares *et al.* (2001) showed that the rate-limiting step of the reaction occurs on the acid sites even for low metal loading catalysts such as 0.53wt.% Pd ion-exchanged on H-ZSM-5 support catalyst. In the same study, Canizares *et al.* (2001) pointed out that the Pd dispersion on PdH-ZSM-5 catalysts was found to decrease when the incorporated metal loading and metal particle size increase. This is in agreement with the studies by M'Kombe *et al.* (1997). The explanation given for the above conclusion was that the zeolites channels are accommodating a portion of Pd that will subsequently lead to high dispersion. Once these zeolites channels have been occupied, additional Pd would be located randomly and grow without restrictions in the zeolites channels or on the external zeolite surface leading to lower metal dispersion. This suggestion is in agreement with the Temperature Programme Reduction (TPR) profile that the area under the peaks at 100-200°C and 400-475°C was integrated to determine the relative proportion of metal particles located in the main zeolite channels and in hidden cages, respectively (Canizares *et al.*, 2001).

2.3.3.2. Pt/Al₂O₃ and Pt/SiO₂

The supported oxide catalysts consist of an oxide deposited on the surface of another oxide. The supported oxide (M) binds to the support (S) *via* bridging M-O-S bonds, which are formed in part by surface hydroxyl groups (Banares, 1999). In 1977, den Otter and Dautzenberg (1978) describe platinum on alumina as a catalyst employed in several important industrial processes. Anderson (1975) claimed that for catalyst containing between 0.1 and 1 wt.% of Pt on γ - or η -alumina, prepared by impregnation and reduced at 500°C has an average metal particle diameter of 1-2nm. The pre-treatment atmosphere and temperature are the most important factors in controlling the Pt particle growth. It was shown that increasing the temperature of hydrogen reduction in the range 450-650°C resulted in an increase in the average Pt particle diameter from 1.1 to 2.1 nm. Additionally, Pt/Al₂O₃ heat treated in an inert nitrogen atmosphere at 600°C for 4 hours had very small effect on the Pt particle size, while heating at 550-600°C in oxygen or air had increased the Pt particle size greatly. The average Pt particle size increased by about 25% when the platinum content increases from 0.75 to 2.83

wt.% and the degree of Pt dispersion obtained by chloroplatinic acid impregnation on Al_2O_3 is better than on SiO_2 of comparable porosity. Similarly to PtH-ZSM-5, the Pt particle size of Pt/ Al_2O_3 is dependent on the pore size of the alumina support. It was stated that an increase in the average pore diameter by a factor of about 2.9 resulted in an increase in the average particle diameter by a factor of about 2.1. Nonetheless, the dependency of the Pt particle size found with SiO_2 support is similar to with Al_2O_3 support (Anderson, 1975).

Catalysts prepared by impregnation of silica with chloroplatinic acid solution giving Pt contents in the range of 0.15-11.5 wt.% showed two distinct regimes for the dependence of the Pt particle size on the Pt loading. In the range of 0.15-3 wt.% Pt, the average Pt particle diameter was remained constant at 3.6 nm. On the other hand, in the range from 3-11.5 wt.% Pt, the average Pt particle diameter increased to about 6-7 nm. The pore structure of the silica gel controls the availability of platinum for the crystal growth, and thus the Pt particle size depends on the structure of the silica. Additionally, the Pt particle size increases with the reduction temperatures and calcining the catalysts in air prior to reduction had relatively strong effect on the final particle size.

2.3.4. Catalyst preparation methods

As mentioned above, metal incorporation techniques, which attach the active phase to the support, is believed to have a significant influence on the final characteristics of the bifunctional catalysts (Anderson and Garcia, 2005; Caeiro *et al.*, 2006). In catalyst manufacturing industry, impregnation is usually employed for practical and economic reasons. Other most common metal incorporation techniques used in producing metal supported bifunctional catalysts are: ion exchange, co-precipitation, mechanical mixture and deposition of metal vapour (Canizares *et al.*, 2001).

2.3.4.1. Impregnation

Ion exchange and impregnation are the most widely used methods in the catalyst modification (Canizares *et al.*, 2001). Impregnation is a process in which porous support

pellets are dipping continuously into a solution containing the desired catalytic agent (metal salt). The agent is dissolved evenly in a predetermined amount of de-ionised water before impregnation into the support pellets (Zadorsky, 1998). Impregnation includes two methodologies: the dry impregnation and the wet impregnation. In dry impregnation, also referred to as ‘pore volume impregnation’ or ‘incipient wetness’, just enough precursor solution is used to fill the pore volume of the support. The solubility of the catalyst precursors and the pore volume of the support determine the maximum loading available each time of impregnation. If a high loading is needed, successive impregnations and heat treatments maybe necessary. In wet impregnation, the support is dipped continuously into an excess quantity of precursor solution which containing the active phase. Three processes occur in the impregnation: (i) the transport of solute to the pore system of the support bodies; (ii) diffusion of solute within the pore system; (iii) the uptake of solute by the pore wall. In the case of wet impregnation, a fourth process is taking place, i.e. the transport of solute to the outer particle surface (Anderson and Garcia, 2005).

2.3.4.2. Ion-exchange

Ion exchange is a process in which ions are exchanged between a solution and an insoluble solid known as ion exchanger (e.g. zeolite). It is a reversible process and the ion exchanger can be regenerated and reused by washing with an excess of the ions to be exchanged (Romero *et al.*, 1996). Strong metal-support interaction can be obtained by ion exchange; however, this method is not suitable for loading high metal concentrations on zeolite supports (Canizares *et al.*, 2001).

Jao *et al.* (1996) proved that higher Pt dispersion was found in the catalysts prepared by ion exchange method compared to those prepared by impregnation method. Romero *et al.* (1996) illustrated that ion exchanged catalysts exhibit smaller and more dispersed metal (nickel) particles compared to the impregnated one. This was proven by temperature program reduction (TPR), where higher reduction temperature was observed on the ion exchanged catalysts than on the impregnated one (Romero *et al.*, 1996). Romero *et al.* (1996) explained that in the TPR experiment, the reduction

temperature could be related to the size of the metal particles or the metal dispersion and/or the metal-support interaction strength. The above statement was supported by the results obtained using SEM and transmission electron microscopy (TEM), where large nickel particles were found in the microscopy photographs for catalysts prepared by impregnation (Romero *et al.*, 1996).

As mentioned in the above sections, the acidic properties of the zeolite supports may be remarkably modified by the incorporation of metal, based on the catalyst preparation methods and precursor used (Romero *et al.*, 1996). The studies showed difference in the strength distribution was found in catalysts prepared *via* ion exchange and impregnation. Additionally, the acidity of zeolite decreases with the incorporation of metal *via* both ion exchange and impregnation, in which the zeolite acidity dropped more significantly in catalysts prepared by impregnation than by ion exchange. The decrease in zeolite acidity could be due to the partial blockage of zeolite pores by large metal particles and the deactivation of the acid centers during calcination of the catalysts (Romero *et al.*, 1996).

The catalysts proceed through a series of heat treatments at various atmospheres, which are known as the pre-treatments of the catalyst, after the incorporation of metal on the support. In addition to the importance of catalyst preparation methods, the pre-treatment of the catalysts is one of the most important factors affecting the final characterisation of the bifunctional catalyst. The pre-treatment processes of the catalysts and their effects on the final catalyst characterisation will be described in detail in next section.

2.3.5. Catalyst pre-treatment procedures

Advanced catalytic systems for the conversion of hydrocarbons are possible to achieve by physically separating the metallic and acidic sites of the catalysts during their preparation. Generally, the metallic component is impregnated or ion exchanged on a catalytically inactive support followed by calcination and reduction procedures (Kuhlmann *et al.*, 2004). Van den Broek *et al.* (1997) pointed out that the pre-treatment

procedures activate the catalyst and have great influence on the position and the size of the metal particles in the catalyst. During calcination and to a lesser extent during drying, the metal compounds on the support decomposed and ultimately obtained the high degree of metal dispersion (Anderson, 1975). Anderson and Garcia (2005) highlighted that the calcination process, especially the heating rate of the pre-treatment of the catalyst system, needs to be well controlled in order to obtain the high metal dispersion.

2.3.5.1. Drying and calcination

The drying procedure has the purpose of removing extra moisture from the catalysts. The drying conditions such as the rate of heating, temperature, duration and gas flowrate over the catalyst affect the properties of the catalysts. The drying process of the impregnated support influences the distribution of metal active sites. Uniform distribution of the metal active sites can be achieved if the liquid evaporated spontaneously. However, the liquid evaporation occurs from the surface of the catalyst particles preferentially in the larger pores where the vapour pressure is higher. The metal active sites will be concentrated in the center of the catalyst particles if the drying process is slow and the metal is completely soluble in the solvent (Ullmann's, 1996a).

Calcination is the heat treatment under an oxidising atmosphere at the temperature slightly above the projected operating temperature of the catalyst. This procedure stabilises the physical, chemical, and the catalytic properties of the catalyst. The pore structure and mechanical strength of the impregnated catalysts can be altered during the calcination steps (Ullmann's, 1996a). The calcination of PtH-ZSM-5 catalyst under high air or oxygen flow with very slow heating rate ($< 1^{\circ}\text{C}/\text{min}$), yielded grey or black colour PtO and the final Pt^{2+} ions are coordinated with four oxygen atoms in a square planar symmetry (Van den Broek *et al.*, 1997). Reversible conversion can occur during the crystalline modifications. As a result, it is important to ensure optimum conditions are applied in the calcination process to achieve the peak catalyst performance (Ullmann's, 1996a).

2.3.5.2. Hydrogen reduction

The catalyst reduction procedure is normally carried out, after calcination in air, by flowing reducing gases such as hydrogen through the reactor at elevated temperature (Franke *et al.*, 2000; Kuhlmann *et al.*, 2004). Many studies have been done to investigate the effects of hydrogen reduction. These studies have shown that hydrogen reduction pre-treatment affects the activity and stability of the catalyst (Franke *et al.*, 2000; Kuhlmann *et al.*, 2004; Roland *et al.*, 1995; van den Broek *et al.*, 1997; Kusakari *et al.*, 2002).

Menon and Froment (1981) established that the hydrogen reduction of a bifunctional catalyst at high temperature (400-700°C) would lead to the disintegration of Pt particles or clusters in Pt supported alumina catalyst to atomic Pt, the enhancement of the metal-support interaction and the stronger hydrogen chemisorption on Pt sites in PtAl₂O₃ catalyst. More detailed studies on the pre-treatment of [Pd(NH₃)₄]²⁺ were reported compared to [Pt(NH₃)₄]²⁺ although both metals behave similarly in the pre-treatment process (Van den Broek *et al.*, 1997).

When hydrogen is used as the reducing gas in a Pt reduction process, the adsorbed oxygen or hydroxyl groups could be removed from the Pt sites, leaving Pt metal (Pt⁰) species. The Pt⁰ species are able to adsorb the spilt-over hydrogen and the removed oxygen atoms will react with gaseous hydrogen feed to form water (Eq. 2.20) (Den Otter and Dautzenberg, 1978).



Autoreduction could occur when helium or air is used in the catalyst pre-treatment step. Pt ions would be reduced by NH₃ ligands forming Pt⁰ atoms. The overall reaction equation of autoreduction is given in Eq. 2.21 (Van den Broek *et al.*, 1997):



The hydrogen pre-treatment reduces the metal ion (such as Ga^{1+} , Pt^{1+}) preferably to metal species (such as Ga^0 , Pt^0). Such catalysts were proved to be very active and selective for alkanes aromatisation reactions (Dooley *et al.*, 1992). On the other hand, Anderson (1975) commented that the generation of Ni^0 are thermodynamically unlikely and the formation of Ni^0 is a highly improbable pathway. With regard to the reduction temperature, a compromise will be necessary between the opposing factors. The tendency for the sintering of the reduced metal decreases, the lower the reduction temperature. Contrarily, the density of metal nuclei produced in the initial reaction increases with the temperature, which leads to smaller metal particles, i.e. high metal dispersion (Anderson, 1975). Additionally, Menon and Froment (1981) showed that when hydrogen reduction was carried out at a high reduction temperature, strong hydrogen chemisorption takes place causing some of the Pt atoms to become unreactive. This decrease of the active Pt sites suppresses the hydrogenolysis reaction (Menon and Froment 1981). Anderson (1975) illustrated that the high metal nuclei density can be achieved by using high hydrogen flow rate and low temperature dehydration of the catalyst before the hydrogen reduction. This section has shown that the pre-treatment conditions, such as the calcination and reduction temperatures, are critical, as severe pre-treatment conditions might damage the catalyst physically or/and chemically which eventually inactivates the catalyst.

2.3.5.3. The effects of pre-treatment procedures

The catalyst pre-treatments, such as calcination and reduction, affect the catalyst stability as well as the catalyst efficiency because the heat treatment modifies the state of the metal and, subsequently, the catalytic properties (Romero *et al.*, 1996). Research efforts have been focused on the effects of catalyst pre-treatment steps on the metal particle size, metal dispersion, metal charge, and metal-support interaction, etc. (Canizares *et al.*, 2001; Folefoc and Dwyer, 1992; Romero *et al.*, 1996; Shpiro *et al.*, 1991). Advanced physicochemical characterisation techniques, such as TEM, SEM, hydrogen (H_2) and/or carbon monoxide (CO) chemisorption measurements, and SAXS, etc. are essential for the analysis of the metal species (Kubicka *et al.*, 2006; Treesukol *et al.*, 2005). The rapid development of spectroscopic methods in recent years has brought

a better understanding of the role of various metal species in certain steps of the process, which is one of the key factors in designing the metal supported catalysts (Kubicka *et al.*, 2006; Stakheev and Kustov, 1999).

A decrease in metal dispersion was observed when the calcination severity increases. Jao *et al.* (1996) agreed with the above observation and added that Pt dispersion is only slightly affected by calcination temperatures lower than 450°C. When the PtH-ZSM-5 is calcined at low temperature (200°C), very small Pt particles with sizes in the range of 6 to 15 Å were observed and the Pt²⁺ could be located in the channels and channel intersections of the zeolite (Folefoc and Dwyer, 1992). On the other hand, if the calcination is carried out at higher temperature (350°C), moderate Pt particle sizes ranging from 6 to 60 Å were found. These platinum ions could probably migrate into the pore system and locate near the pore mouths. With further increase of the activation temperature to 450°C, fairly large Pt particles were formed, and could result in the migration of the Pt²⁺ ions out of the pore system and position on the external surface of the zeolite crystals (Folefoc and Dwyer, 1992; Shpiro *et al.*, 1991). When these metal atoms migrate to the so-called 'hidden position', they become more difficult to reduce and are able to reach highly coordinated and extremely stable states (Canizares *et al.*, 2001). The above assumptions were validated by Canizares *et al.* (2001) using TPR, where the results showed that metal particles located on the external surface of the zeolite crystals can be reduced at low temperature (100-200°C) while high reduction temperature (400-475°C) is required to reduce particles located in the zeolite channels and channel intersections. Folefoc and Dwyer (1992) showed that the size of the Pt particles supported on ZSM5 zeolite is the function of the calcination temperature in oxygen. The Pt particle sizes of Pt supported X and Y zeolites, i.e. zeolites with large pore systems, are also directly proportional to the calcination temperature in oxygen. Bragin *et al.* (1986) claimed that the PtH-ZSM-5 catalyst reduced at 500°C in hydrogen contains large metal crystallites 30-150 Å in size on the external surface together with finely dispersed Pt particles (≤ 10 Å) located in the channel mouths.

Treesukol *et al.* (2005) developed an optimised structure of PtH-ZSM-5 which has indicated clearly the interaction between the Pt atom and the terminating hydrogen atoms and predicted that the Pt atom would bind only to the Brønsted proton (Fig. 2.20).

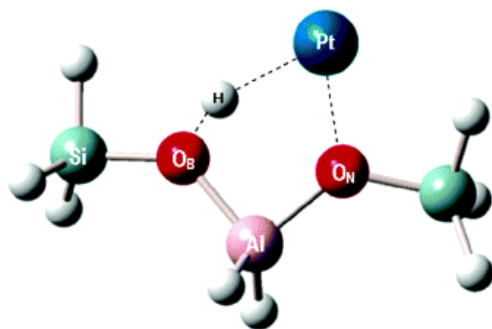

Figure 2.20. The optimised structures of the active sites of monatomic Pt on H-ZSM-5 (Treesukol *et al.*, 2005).

It was noted that the Pt atom bound very weakly on zeolite surface without the acid sites. Hence, the Brønsted proton, which stabilises the Pt atom by withdrawing excess electron density from the Pt atom, is necessary for binding a Pt atom to the zeolite framework.

Han *et al.* (2005) pointed out that the strength of the metal-support interaction, which is influenced by catalyst preparation procedures, pre-treatment, as well as the choice of support material, affects significantly the Pt particle size and the surface morphology. The three-dimensional Pt particles were observed on Pt/Al₂O₃ with reduction at 300°C and the metal-metal bonds in the Pt cluster are stronger than the metal-support bonds. However, upon reduction at 450°C the morphology of the platinum particles changed from three-dimensional to flat or ‘raft-like’ structure. The formation of the flat particles could be attributed to the removal of a hydrogen layer between the Pt particle and the alumina surface as evidenced by shortening of the Pt-O distance from 2.7 to 2.2 Å (Fig. 2.21) and significantly longer metal-metal bonds were observed. A stronger interaction between the Pt particle and oxygen atoms would be expected and thus, the formation of the ‘raft-like’ structure is thermodynamically more preferable. The investigation by Canizares *et al.* (2001) over PdH-ZSM-5 catalysts showed results

similar to those obtained for PtH-ZSM-5 catalysts by Folefoc and Dwyer (1992): severe reduction temperature ($>500^{\circ}\text{C}$) has led to metal sintering and hence, decreases the metal dispersion. All the above results are in good agreement with the work carried out by Anderson (1975) claiming that high degree of platinum dispersion ($D_{\text{Pt}} \approx 1$) was obtained for $[\text{Pt}(\text{NH}_3)_4]^{2+}$ exchanged sample calcined in air at 350°C , followed by hydrogen reduction at 400°C .

The formation of raft-like Pd particles was detected in low-loaded 0.1 wt.% Pd/ Al_2O_3 catalyst after high temperature reduction by combined study of TEM, XPS, and H_2 chemisorption measurements. An increase in the Pd loading up to 0.3 wt.% results in the formation of bulk-type particles and strong interaction between the support and metal was observed on 0.09 wt.% Pd/ Al_2O_3 (Stakheev and Kustov, 1999). Furthermore, Shpiro *et al.* (1991) agreed that larger average Pt particle size would be formed at higher metal loading catalysts.

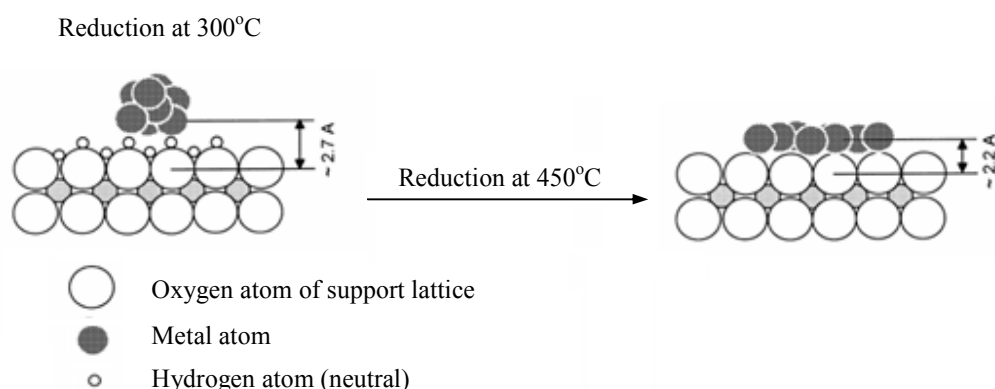

Figure 2.21. Scheme of the structure of the metal-support interface after reduction at 300°C and 450°C (Stakheev *et al.*, 1999).

The metal-support interaction has influenced significantly the morphology, dispersion and charging of the metal particles and these factors determine the catalytic properties of the supported metals. In the hydrogenolysis of ethane, propane, n-butane and iso-butane, the highest activity was demonstrated by Pt/ Al_2O_3 compared to Pt/ SiO_2 ,

which was related to strong adsorption of alkane fragments on electron-deficient platinum sites. Hence, the structural sensitivity of hydrogenolysis is more likely related to the electronic perturbation of the platinum particles rather than the existence of special sites or faces of the metal crystallites (Jackson *et al.*, 1998). Meriaudeau *et al.* (1982) illustrated that the reduction at high temperature (500°C) of TiO₂-supported noble metals results in a strong metal-support interaction leading to the suppression of the metal capacity for hydrogen chemisorption and also to the suppression of the catalytic activity for dehydro/hydrogenation and hydrogenolysis reactions. The metal particle size remained almost unchanged after heat treatment in hydrogen at 500°C suggested that the high H₂ reduction temperature does not act by a sintering effect but rather by producing the strong metal-support interaction which suppress hydrogen chemisorption and the catalytic activity (Meriaudeau, *et al.*, 1982; Den Otter, *et al.*, 1978).

This literature review showed detailed investigation on the current commercial processes producing EB. In-depth reviews on the reaction pathways of the conversion of light alkanes into light alkenes and aromatics hydrocarbon were carried out. The catalysts that involved in the new catalytic pathways for EB production as well as the catalyst preparation methods and conditions were reviewed. It should be noted that the reaction and the catalysts preparation conditions of the catalytic experiments and reasons of the selections will be discussed as detailed in Chapter 3.

Chapter 3

Experimental Materials and Methodology

3.1. Catalyst preparation

The literature reviews showed the catalyst properties, such as metal dispersion and metal particle size, are affected by the catalyst preparation procedures and the conditions. Hence, the catalyst preparation methods and conditions as well as the operating procedures of the catalytic rig are described in detailed in this section.

3.1.1. Calcination

The catalyst being studied is PtH-ZSM-5. The parent catalyst was supplied by Johnson Matthey in ammonium form, i.e. NH₄-ZSM-5. The NH₄-ZSM-5 zeolite (e.g. 1g) was calcined into H-ZSM-5 and the temperature profile of the calcination steps is given in Figure 3.1. The calcination temperature was increased at the rate of 1°C per minute (2) to 490°C (3). Once the temperature reached 490°C, it was sustained for 4 hours, and after that the temperature was reduced at the rate of 2°C per minute (4) to 20°C (5).

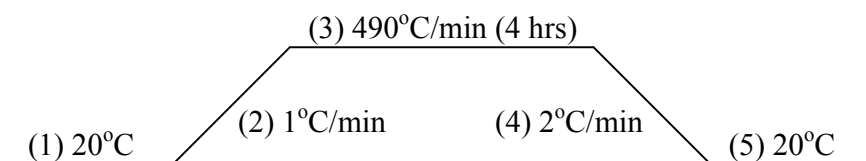

Figure 3.1. Temperature profile of the calcination steps of H-ZSM-5 catalyst.

3.1.2. Impregnation

The PtH-ZSM-5 bifunctional catalyst was prepared by the incorporation of metal into the H-ZSM-5 support *via* incipient wetness impregnation method. The incipient wetness impregnation method was chosen because it is one of the most widely used catalyst preparation methods. Additionally, the impregnation procedures which are straightforward require basic apparatus and the impregnated catalysts, which were not washed, would produce similar designed and actual metal loading (Lambert and Gonzalez, 1998). The minimum volume of water to wet the specific amount of H-ZSM-5 was pre-determined and the platinum precursor, Pt(NH₃)₄(NO₃)₂, was dissolved into this known amount of water forming the platinum precursor solution. The

$\text{Pt}(\text{NH}_3)_4(\text{NO}_3)_2$ salt must be completely dissolved in the solvent before impregnated into the support, H-ZSM-5 zeolite, to ensure even distribution of Pt. The catalyst was then left to dry overnight at room temperature and was crushed into powder form the next morning. After that, the powdered PtH-ZSM-5 catalyst was calcined in the muffle oven using the following temperature profile (Fig. 3.2). The calcination temperature increased at the rate of 1°C per minute (2) to 530°C (3). Once the temperature reached 530°C , it was sustained for 4 hours before the temperature was reduced at the rate of 2°C per minute (4) to 20°C (5).

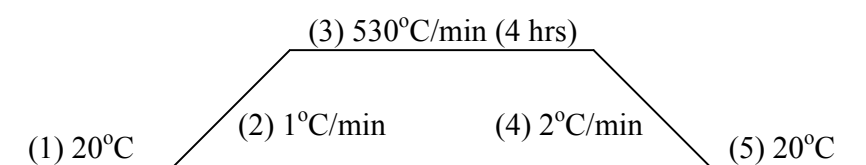

Figure 3.2. Temperature profile of the calcination steps of PtH-ZMS-5 catalyst.

3.2. Kinetic Studies

The kinetic studies of the catalytic reaction were carried out on the catalytic rig. The catalytic rig consists of various components and each component, as well as its operating procedures, is described in this section.

3.2.1 Catalytic rig

3.2.1.1. Gases

The gases that mainly serve the catalytic rig and their functions are outlined in Table 3.1.

Table 3.1. Important gases and their functions.

Gases	Functions
Air	Producing a flame in the flame ionisation detector (FID) of the gas chromatograph (GC); Activation of catalyst.
Ethane	Reactant of the chemical reactions
Hydrogen	Producing a flame with air in the FID of the GC; Pre-treatment of catalyst (reduction of metal sites).
Nitrogen	Purge the system.
Argon	Continuously purge into GC to prevent the burning of the filament in the thermal conductivity detector (TCD); Carrier gas for GC analysis.

3.2.1.2. Distribution system

The gases mentioned above are transported from the gas cylinder to the experimental rigs using one-quarter ($\frac{1}{4}$) inch pipes. Figure 3.3 depicts that the gases pass over a bridge to the catalytic rig and reach the cut off valves, then the distribution system or/and the GC. Figure 3.4 shows that the distribution system consists of two sections: purgemeters and mass flow controllers (MFCs). Purgemeters control the flow of air, H_2 , Ar and N_2 and have the level of accuracy of ± 2 ml/min. These gases are used mainly in the pre-treatment processes and these do not require precise flowrates. The exit streams of the purgometer pass through a three-way valve labelled 'V1' (Fig. 3.5). Figure 3.5 clearly indicates that O_2 , air and N_2 pass through a cross-junction together but H_2 is flowed to 'V1' through its own pipe. This is to reduce the possibility of mixing H_2 and air in this junction that could cause a risk of explosion. On the other hand, MFCs give precise flow control to hydrocarbons (e.g. ethane, propane), N_2 and H_2 . Precise feed composition could be monitored by the MFCs, as MFCs are capable of overcoming the backpressure problems and produce the set value flow rate. Upon exiting the MFCs, the gases pass through to a saturator and reach the second three-way valve labelled 'V2' (Fig. 3.5). The MFCs are manipulated by programming the Brooks Mass Flow Controller, and the calibration of the MFCs is essential to ensure the actual flow rate is at the set value.

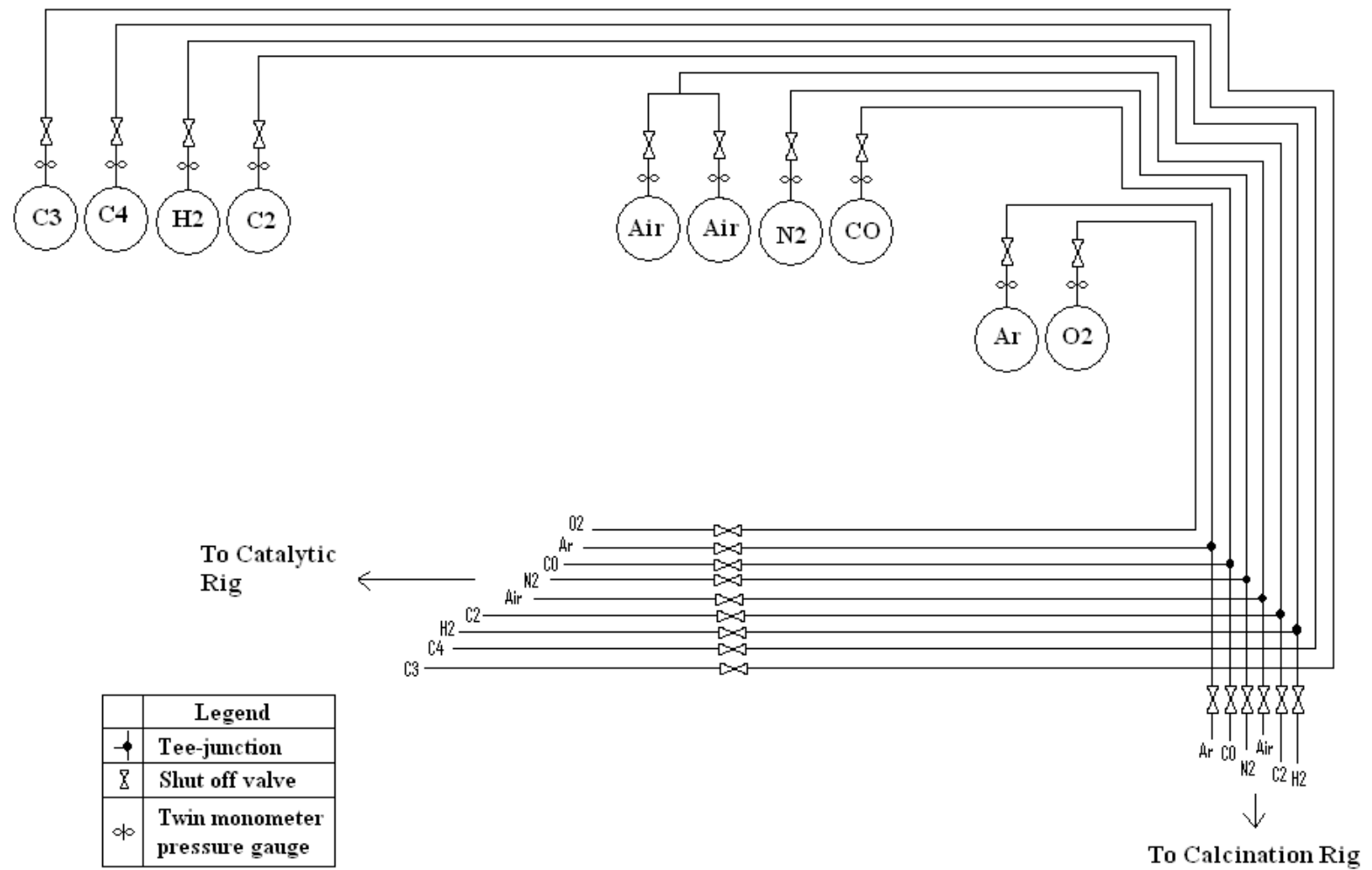

Figure 3.3. Pipelines distribution.

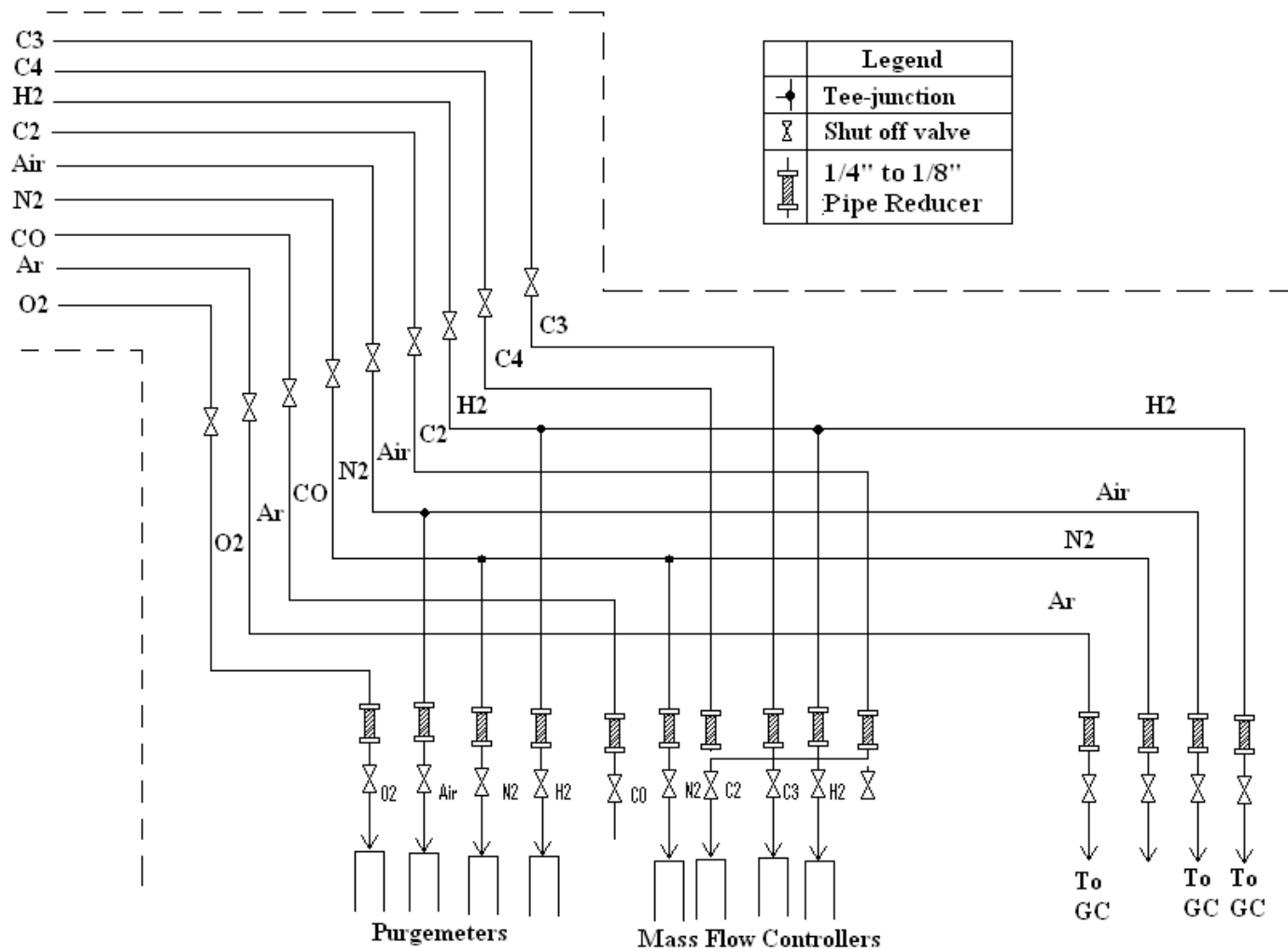

Figure 3.4. Gas distribution scheme 1.

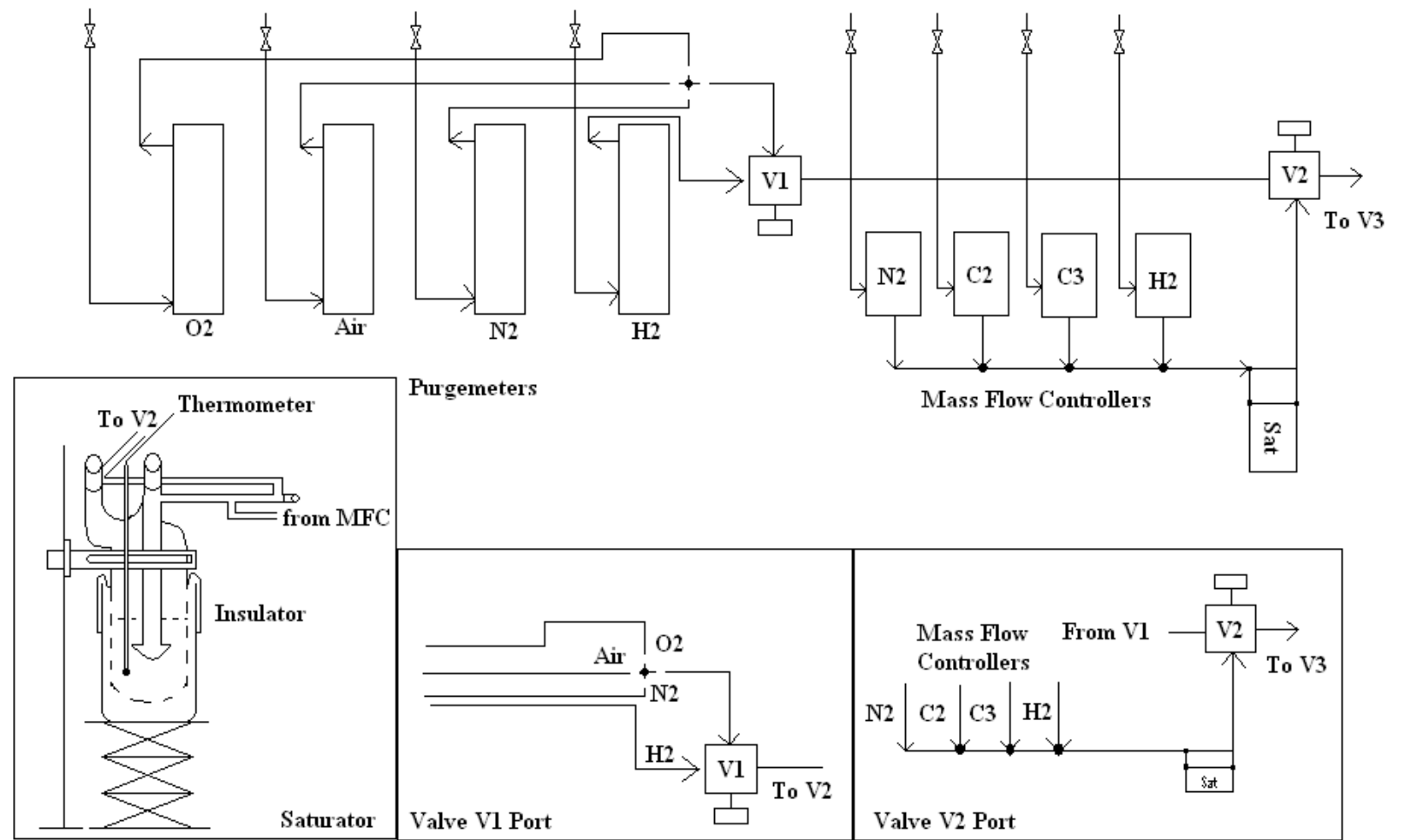

Figure 3.5. Gas distribution scheme 2.

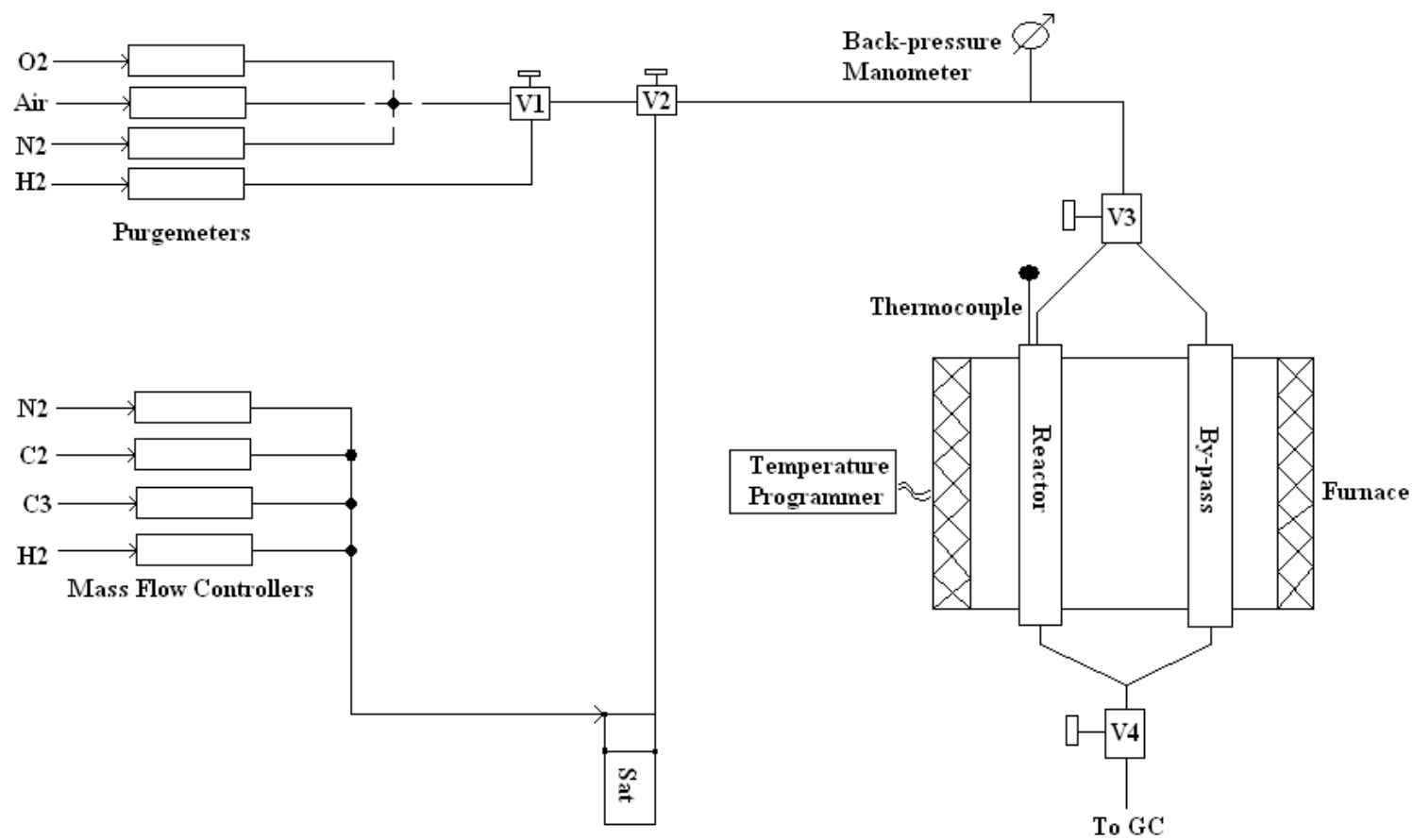

Figure 3.6. Catalytic rig layout.

3.2.1.3. Saturator

As mentioned in section 3.2.1.2, downstream of the MFCs is a saturator containing the liquid phase reactant. The gaseous phase reactants (e.g. hydrocarbons) pass through MFCs, then flow into the saturator and allow absorption between these two different phases of reactants. The saturator is connected to a three-ways valve, where the gaseous reactants can either by-pass the saturator or pass through it. The gas phase reactants are bubbled into the liquid chemical through a perforated tube, which allow the gas to be evenly distributed in the liquid. The ratios of the reactants are affected by the vapour pressure of the volatile liquid reactant, which is highly influenced by temperature. As a result, the saturator is placed in a thermo flask to keep the liquid phase benzene at a specific temperature throughout the experiments. The saturator and the reactor are linked by the $\frac{1}{8}$ inch tube *via* the three-ways valve 'V2' (Figure 3.5). A manometer is installed on the line to show the level of backpressure across the reactor. If there is a downstream blockage in the pipeline, the manometer reading will increase continually and immediate action should be taken (Figure 3.6).

3.2.1.4. Reactor and by-pass

The reactant stream passes through either the reactor or the by-pass line which are located in the furnace. Figure 3.6 illustrates this system. The by-pass line, which is a stainless steel pipe, allows reactant flow to stabilise before feeding to the reactor. Besides that, the flow is directed to the by-pass line when the reactor is removed to be cleaned or reloaded. The reactor is a Pyrex glass tube that is usually packed with catalyst, quartz wool and carborundum. The thermocouple is placed as close as possible to the catalyst for the precise detection of the catalyst temperature. The heating elements are installed in the furnace, mastering the reactor temperature. The reactant stream passes through the reactor and the products are directed into the GC *via* a $\frac{1}{8}$ inch tube, which is wrapped with a heating tape and insulator to prevent condensation of the product mixture.

3.2.1.5. Gas chromatograph

The model of the GC in the catalytic laboratory is Varian CP-3800GC. This GC consists of two ovens: the valve oven and the column oven. The gas sampling valve system, which consists of four valves, is located in the valve oven but only two of them, the valves labelled three (V3) and four (V4), were used. V3 is a 10-ways valve while V4 is a 6-ways valve. The product gas flows with the carrier gas, Ar, to the column oven by switching the position of V3 and V4 simultaneously. The column oven consists of two columns; the column that feeds the separated products into the TCD is a 1m long molecular sieve column. The TCD is used to detect H₂, N₂, O₂ and some of the light alkanes such as methane and ethane. The detector contains a filament through which electricity passes and uses Ar to prevent the filament from overheating. On the other hand, FID is capable of detecting hydrocarbons by producing a flame using H₂ and air. The product gas is split with the split ratio of 40:1, where 40 segments of the product mixture are purge to the exhaust and one segment goes into the column, before entering a 25m capillary column known as porous layer open tubular-alumina (PLOT-Al₂O₃) column. Each component of the product mixture moves through the columns at a different velocity. As a result, each compound will emerge from the columns in a specific order, i.e. lightest to heaviest molecules, and the time taken for each component to be omitted from the columns is known as the retention time. Prior to the GC analysis, the retention time of each product in the column is pre-determined by calibration.

3.2.1.6. Temperature Controller

The temperature controller allows the reactor to be heated by the heating elements in the furnace based on a predetermined temperature program. The predetermined temperature program consists of different individual segments that allow the reactor to be heated or cooled at a specific rate as well as dwell at a specific temperature. It is important to ensure the program is set correctly before switching on the controller.

3.2.2. Operating procedures

3.2.2.1. Fraction preparation

The powder form PtH-ZSM-5 bifunctional catalyst was packed into a reactor for the catalysis studies. However, due to the lack of voidage between particles which is likely to cause large and undesired backpressure, the powder is prepared into a fraction. The powder form PtH-ZSM-5 was pressed into discs using a DIE with 5 tonnes of pressure and the discs were crushed and sieved using 250-500 μm meshes, hence creating a fraction.

3.2.2.2. Charging the reactor

The catalysts prepared in fractions was packed in the middle of a pyrex reactor and between an inert material called carborundum. The carborundum provides even distribution of the feed gas, reduces the temperature gradient between the reactant mixture and catalyst layer and ensuring constant reaction temperature along the catalyst bed. The layers of catalyst and carborundum were separated by layers of quartz wool and the thermocouple which was connected to the reactor, was located on the upper layer of quartz wool (Fig. 3.7).

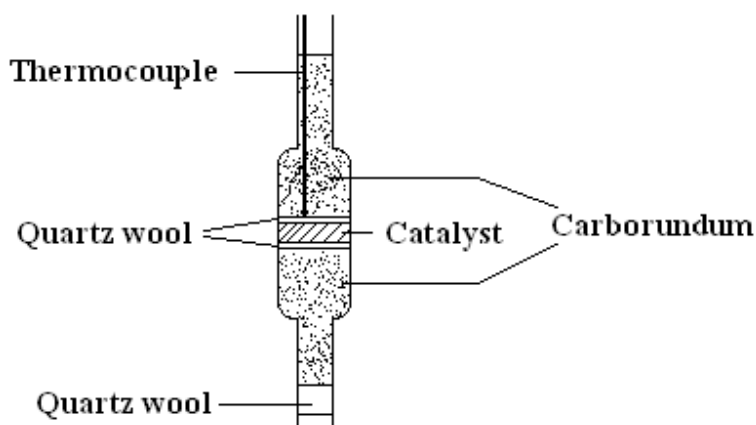

Figure 3.7. Schematic of the reactor set-up.

The thermocouple must not be in direct contact with the catalyst to eliminate the probability of damaging the catalyst, but must be close enough to get an accurate interpretation of the catalyst temperature. As a result, the quartz wool layers separating the active and inert materials were approximately 2 mm thick. Firstly, a layer of quartz wool around 2 cm in length was inserted from the bottom end of the reactor. This was packed very tightly and has the function of supporting the lower level of carborundum. 2 mm of quartz wool was packed on top of the lower level of the carborundum and the catalysts would be rested on it. The catalysts were then separated from the upper level of carborundum by another layer of quartz wool (approximately 2 mm). Finally, the thermocouple was placed as close as possible to the catalyst layer, then the upper level of carborundum was loaded into the reactor.

3.2.2.3. Installing the reactor

The loaded reactor was reinstalled into the furnace and the possible gas leakages from the fittings were checked by applying soapy foam to the joints whilst purging N₂ through the line. Bubbles will evolve from the foam if there is any gas leakage. The reactor was installed in the middle of the furnace, and quartz wool that plugs the air holes of the furnace was able to hold the reactor in place as well as reduce the amount of heat loss. The reactor exit lines were connected to the GC and these lines were heated to prevent the condensation of the aromatic products.

3.2.2.4. Pre-treatment of the catalyst

Catalysts that are loaded in the reactor need to be activated prior to the catalytic reactions. The removal of moisture in catalyst was carried out under the chosen temperature profile in a specific gaseous environment. The desired temperature profile (Fig. 3.8) was set-up in the Carbolite temperature programmer and the catalyst samples were activated overnight in air at a flow of 30 ml/min. The calcination temperature profile increased at the rate of 1°C per minute (2) to 530°C (3). Once the temperature reached 530°C, it was sustained for 4 hours. Then, the temperature was reduced at the rate of 2°C per minute (4) to 200°C (5).

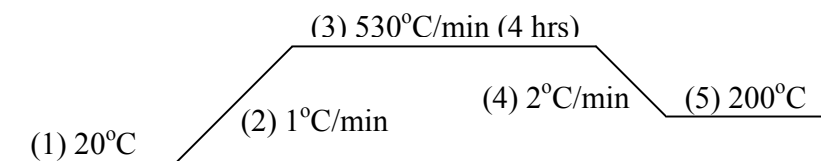

Figure 3.8. Temperature profile of the activation of PtH-ZMS-5 catalyst in air at the flow of 30 ml/min.

The activation procedure would be completed in the following morning then, the system was purged with N₂ at the flow of 50 ml/min for 1 hour. The GC analysis was carried out to ensure that only a negligible amount of O₂ was remained in the system as the next stage of the catalyst pre-treatment involved the introduction of H₂ into the system. The catalyst was reduced in a H₂ flow of 60 ml/min after the complete discharge of air from the system and the reduction temperature profile was altered as follow (Fig. 3.9).

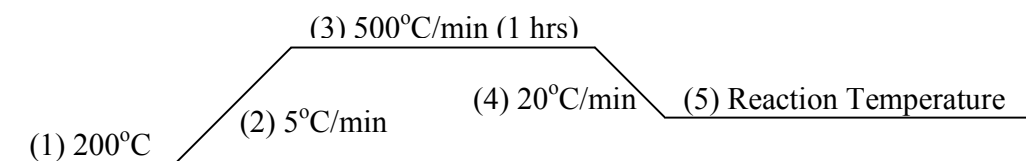

Figure 3.9. Temperature profile of the reduction of PtH-ZMS-5 catalyst in H₂ at the flow of 60 ml/min.

3.2.2.5. Catalytic experiments

The catalytic reaction would be performed on the catalysts which were activated by the pre-treatment procedures. The by-pass stream was used to obtain the correct composition of the reaction gas, and ensuring the same reactant composition at any point of the catalytic reaction. The ethane flow passed through the saturator that contained benzene and the saturator was maintained at 20°C, in which the vapour pressure of benzene is 10 vol.%. The gas stream was redirected to the reactor channel once the desired composition of the reactant mixture was achieved. The first analysis of the products was done at 1 hour after the reaction commences, on the Varian CP-3800GC.

3.2.3. Analysis of products

A wide range of products were formed in benzene alkylation with ethane into EB over Pt-containing ZSM-5 bifunctional catalyst and these products were detected by FID and TCD in the GC. In order to identify these products, calibrations was carried out to establish the retention time of the possible products of benzene alkylation with ethane into EB. As the TCD and FID data are calibrated differently, a normalization coefficient is needed to convert the peak areas of components detected by TCD into the areas they would have been, had they been detected alongside the FID. The method of obtaining this coefficient will be described in this section. The Varian CP-3800GC provides both the graphical form chromatogram and the numerical form of the peak areas. These peak areas determine the concentration of each product in the product mixture and will be calculated into the product selectivities, reactant conversions, etc.

3.2.3.1. Calibrations

The GC analysis of a known composition of calibration mixture was to determine the retention time of each chemical species on the specific detectors under the selected operating temperature settings. All hydrocarbons in the product stream during the catalytic experiment are detected by FID and some components from the product stream such as H₂ are detected by TCD. The peak areas detected on the TCD will not necessary indicate the same mass of a component as if they had been detected on the FID. As a result, coefficients converting the peak areas of components detected by TCD into the areas they would have been, had they been detected alongside the hydrocarbons on the FID are required. These coefficients can be calculated by carrying out GC analysis on a known composition of calibration mixture. The calibration mixture was pre-ordered from Supelco and the given compositions are shown in Table 3.2.

Table 3.2. Composition of calibration mixture.

Chemical Species	Concentration (mol%)
CO ₂	1
CO	1
H ₂	1
CH ₄	1.01
O ₂	1
N ₂ (balance)	94.99

Prior to the calibration, some preparations were essential. Firstly, a flexible tube was prepared and connected to the inlet of valve system. It is important to ensure the heating line that was previously connected to the inlet of the valve system, was cooled to room temperature before unwrapping the insulator and disconnecting. Secondly, the calibration mixture was transferred into the gas syringe by a plastic tube (packed inside the cap of the calibration mixture cylinder). The known amount (about 40ml) of calibration mixture was transferred slowly and carefully into the gas syringe when the connections were held tightly. After that, the gas syringe was immediately connected to one end of the flexible tube where the other end of the flexible tube was connected to the inlet of the valve system. The gas mixture was injected slowly into the valve system and the GC analysis would start after half of the injection was completed, i.e. when approximately 20 ml of the mixture was injected into the valve system, to ensure the sample loops in valve 3 were filled with the gas mixture. The GC analysis was suspended after all components being analysed were shown in the chromatogram. The injection was repeated for accuracy and reliability.

The mass of each component in 100 moles of gas mixture is calculated as follows:

$$m_x = MW_x \times C_x$$

$$m_{H_2} = 2 \frac{g}{mol} \times 1mol = 2g$$

$$m_{CH_4} = 16 \frac{g}{mol} \times 1.01mol = 16.16g$$

m_x = mass of species x, g

MW_x = molecular weight of species x, g/mol

C_x = molar percentage of species x, mol.%

The peak area of CH₄ detected from the FID is 37977 and denotes A_{H_2FID} as the peak area of H₂ if it had been detected on the FID channel.

Components	Mass (g)	Peak area
H ₂	2	A_{H_2FID}
CH ₄	16.16	37977

$$A_{H_2FID} = \frac{2 \times 37977}{16.16} = 4700.12$$

The coefficient that converts the peak area of H₂ detected on the TCD into the areas they would have been, had they been detected alongside the hydrocarbons on the FID is denoted as K_{H_2} . This coefficient is simply the ratio of the peak areas of the specific component detected by the FID and the TCD.

$$K_{H_2} = \frac{A_{H_2FID}}{A_{H_2TCD}}$$

The peak areas of H₂ obtained from the TCD chromatograph, 93223, can now be substituted to calculate the value of the coefficient for H₂,

$$K_{H_2} = \frac{A_{H_2FID}}{A_{H_2TCD}} = \frac{4700.12}{93223} = 0.050$$

3.2.3.2. Chromatograms and peak area table

The products of the catalytic reaction are identified by TCD and FID based on the difference in retention time of each component in the columns and the amount of each

product is determined by the peak area. The hydrocarbons are detected by FID while the components such as N₂, O₂ and H₂ are detected by TCD. Figures 3.10 and 3.11 show the graphical form chromatogram (Fig. 3.10) and the numerical form (Fig. 3.11), respectively, of the peak areas obtained in one of the GC analysis.

3.2.3.3. Calculations

(a) Feed flowrate

The soap meter is used to determine the actual flow rate flowing through the system. The volumetric flow rate of the gas can be easily calculated using the following method. The time of the soap bubble travelled through a specific distance of the burette-style tube is recorded.

$$\frac{\text{Volume traveled (ml)}}{\text{Time taken (s)}} \times \frac{60 \text{ s}}{1 \text{ min}} = \text{Volumetric flowrate (ml/min)}$$

(b) Weight hourly space velocity (WHSV)

Weight hourly space velocity (WHSV), which is an important parameter in reaction analysis, is defined as the mass of feed per mass of catalyst per hour (Eq. 3.1). Hence, the WHSV is inversely proportional to the length of the catalyst bed at constant feed flowrate, same reactor diameter, catalyst packing and void fraction.

$$\text{WHSV} \quad (\text{g}_{\text{feed}}/\text{g}_{\text{cat}} \cdot \text{h}) = \frac{\text{Total feed mass flowrate}}{\text{Catalyst mass}} \quad (3.1)$$

According to the above formula, the conversion of feed volumetric flowrate into feed mass flowrate is needed. The total feed mass flowrate is simply the summation of all feed components flowrates, in this case the summation of ethane and benzene flowrates.

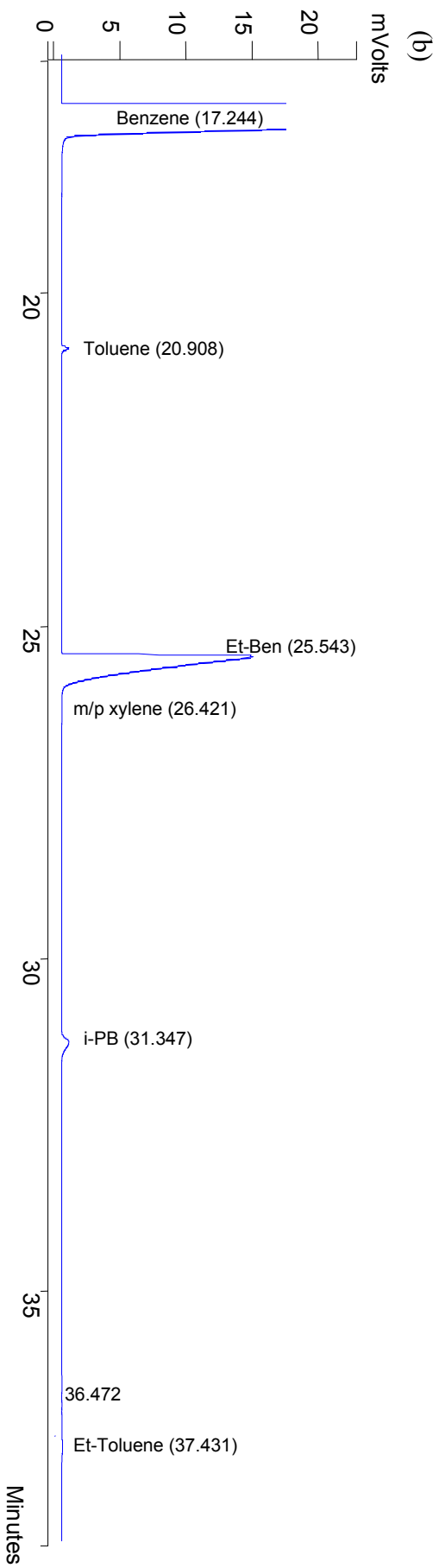
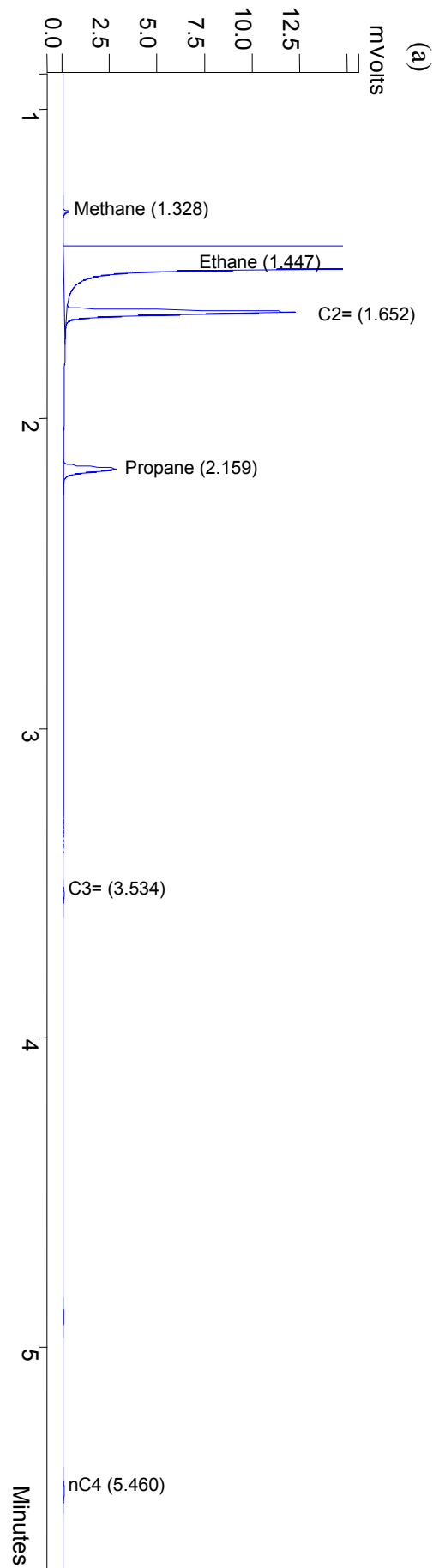

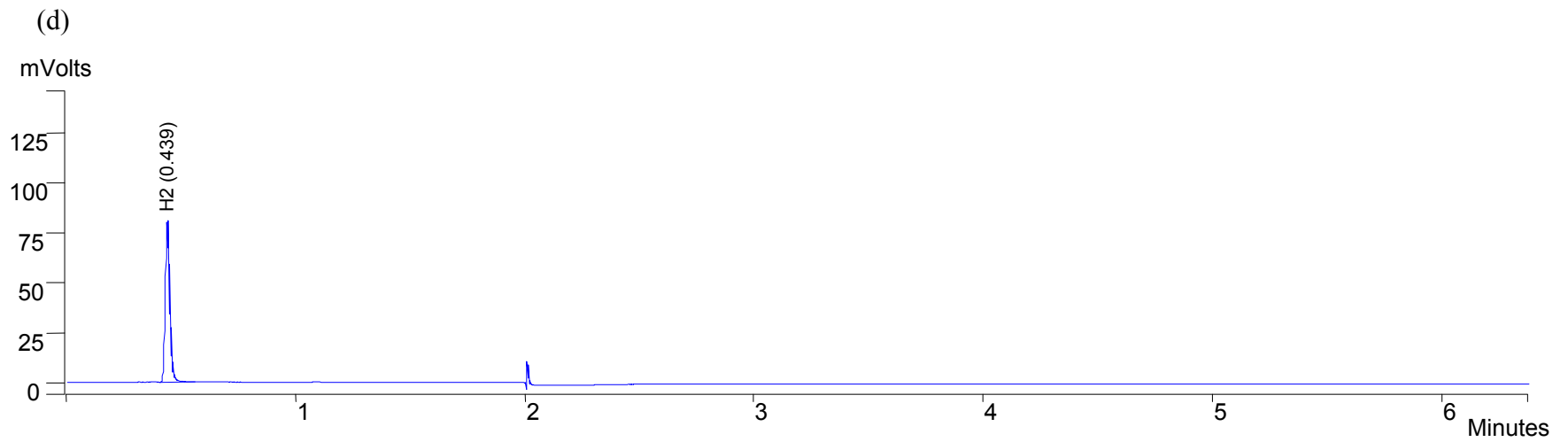
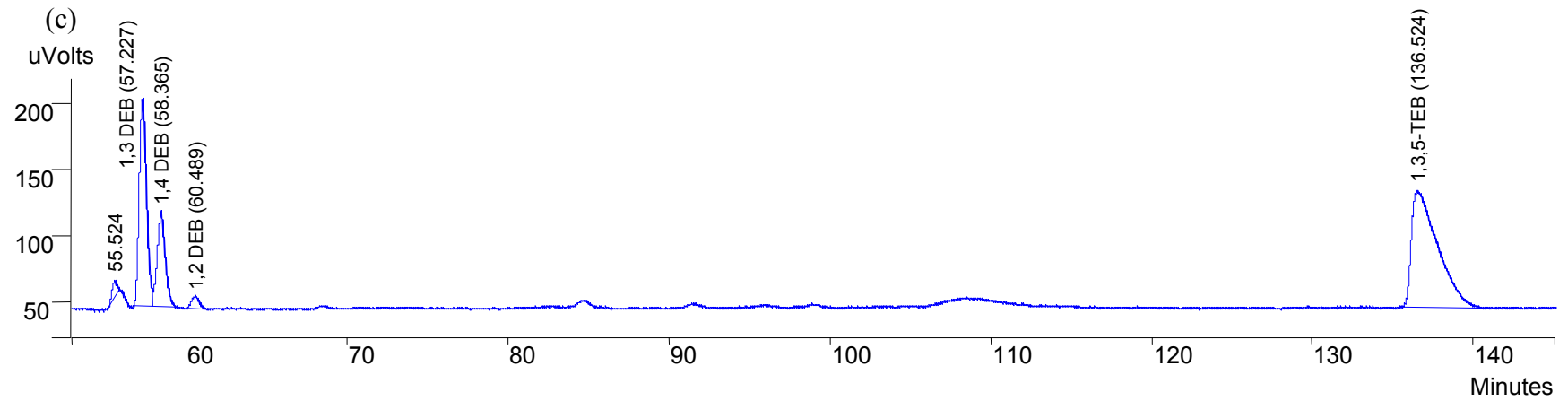

Figure 3.10. The chromatograms of chemical components that detected by (a)-(c) FID and (d) TCD.

(a)

Print Date: Mon Mar 03 17:50:41 2008

Page 1 of 1

Title :
Run File : c:\star\data\ivy\benzene alkylation with ethane\experiments\1\pt + h-zsm5(80)\370c\500mg'
Method File : c:\star\methods\ivy.mth
Sample ID : 173-eth

Injection Date: 13/06/06 10:18 Calculation Date: 13/06/06 13:15

Operator : Tanya Detector Type: 3800 (10 Volts)
Workstation: Bus Address : 44
Instrument : 3800 GC Sample Rate : 10.00 Hz
Channel : Middle = FID Run Time : 163.397 min

** Star Chromatography Workstation Version 5.51 ** 01350-6320-082-0704 **

Run Mode : Analysis
Peak Measurement: Peak Area
Calculation Type: Percent (Normalized Results)

Peak No.	Peak Name	Result ()	Ret. Time (min)	Time Offset (min)	Area (counts)	Sep. Code	Width 1/2 (sec)	Status Codes
1	Methane	0.0022	1.328	-0.005	196	BB	0.6	
2	Ethane	70.3798	1.447	-0.023	6303488	BB	1.5	
3	C2=	0.1394	1.652	0.011	12487	TS	0.0	
4	Propane	0.0379	2.159	-0.031	3399	BB	1.1	
5	C3=	0.0016	3.534	0.055	141	BB	1.9	
6	nC4	0.0026	5.460	0.018	232	BB	2.7	
7	Benzene	26.3187	17.244	-0.309	2357210	BB	12.6	
8	Toluene	0.0262	20.908	0.242	2344	BB	3.2	
9	Et-Benz	2.7862	25.543	0.071	249542	BB	12.9	
10	m/p xylene	0.0025	26.421	0.202	228	TS	0.0	
11	i-PB	0.0847	31.347	0.630	7585	BB	10.5	
12		0.0024	36.472	0.000	213	BB	14.2	
13	Et-Toluene	0.0140	37.431	0.020	1250	VB	13.7	
14		0.0033	55.524	0.000	297	BB	0.0	
15	1,3 DEB	0.0556	57.227	0.016	4983	BV	30.1	
16	1,4 DEB	0.0279	58.365	0.018	2495	VB	31.8	
17	1,2 DEB	0.0037	60.489	-0.000	328	BB	31.4	
18	1,3,5-TEB	0.1114	136.524	1.386	9975	BB	106.4	
Totals:		100.0001		2.301	8956393			

Total Unidentified Counts : 510 counts

Detected Peaks: 25 Rejected Peaks: 7 Identified Peaks: 16

Multiplier: 1 Divisor: 1 Unidentified Peak Factor: 0

Baseline Offset: 32 microVolts

Noise (used): 3 microVolts - monitored before this run

Manual injection

(b)

```
Print Date: Mon Mar 03 17:49:46 2008          Page 1 of 1
Title :
Run File : c:\star\data\ivy\benzene alkylation with ethane\experiments\1%pt + h-zsm5(80)\370c\500mg
Method File : C:\Star\Methods\Ivy.mth
Sample ID : 173-eth

Injection Date: 13/06/06 10:18      Calculation Date: 13/06/06 13:01

Operator : Tanya                      Detector Type: 3800 (10 Volts)
Workstation:                          Bus Address : 44
Instrument : 3800 GC                   Sample Rate : 10.00 Hz
Channel : Front = TCD                 Run Time : 163.397 min

* Star Chromatography Workstation Version 5.51 ** 01350-6320-082-0704 **

Run Mode : Analysis
Peak Measurement: Peak Area
Calculation Type: Percent (Normalized Results)

Peak No.   Peak Name   Result   Ret. Time   Time Offset   Area   Sep. Code   Width   Status
          ( )         (min)    (min)      (min)         (counts) (sec)      (sec)   Codes
-----
1 H2       99.1420    0.439   -0.038     112175       BB      1.3
2          0.1480    21.625   0.739      167          BB      0.9
3          0.1542    34.584   0.000      174          BV      2.4
4          0.0970    39.426   0.000      110          BB      0.6
5          0.1023    55.482   0.000      116          BB      0.0
6          0.0958    108.426  0.000      108          BB      0.4
7          0.1351    112.424  0.000      153          BB      0.0
8          0.1256    115.216  0.000      142          BB      0.0
-----
Totals:    100.0000          0.701     113145

Total Unidentified Counts :          803 counts
Detected Peaks: 48      Rejected Peaks: 40      Identified Peaks: 2
Multiplier: 1          Divisor: 1              Unidentified Peak Factor: 0
Baseline Offset: -6 microVolts
Noise (used): 53 microVolts - monitored before this run
Manual injection
At Least One Peak Has Wrong Calibration Calc Type
Data Handling: Default to A%
*****
```

Figure 3.11. Numeric form of peak areas obtained by (a) FID and (b) TCD.

Total mass flow (g_{feed}/h) = Ethane mass flow + Benzene mass flow

$$\begin{aligned} \text{Mass flow (g}_{\text{feed}}/h) &= \text{Volumetric flow (ml/min)} \times 60 \text{ (min/h)} \times 0.001 \text{ (L/ml)} \times \text{Molar mass (g/mol)} \\ &\times \frac{1}{22.4} \text{ (mol/L)} \end{aligned}$$

In an ideal plug-flow reactor, the time that the atoms have spent in the reactor is called the residence time (τ) and is obtained from dividing reactor volume by the volumetric flowrate entering the reactor (Fogler, 2006).

$$\begin{aligned} \tau &= \frac{\text{Catalyst mass}}{\text{Total feed mass flowrate}} \times \frac{\text{Feed density}}{\text{Bulk density of catalyst bed}} \\ &= \frac{\text{Volume of catalyst bed}}{\text{Total volumetric feed flowrate}} \end{aligned} \quad (3.2)$$

It should be noted that the contact time that is used in this thesis is different from the residence time. The contact time is dividing catalyst mass by the feed mass flowrate (Corma *et al.*, 2000; Moreau *et al.*, 2002; Smirnov *et al.*, 2000; Speight and Ozum, 1979).

(c) Feed conversions

The conversion of benzene and the conversion of the ethane are determined. It was assumed that the one mole of aromatic is formed from one mole of benzene and that all of the aromatics are formed from the benzene. The benzene feed is made up of the sum of the concentration of reacted and unreacted benzene (Eq. 3.3).

$$X_{\text{Benz}} (\%) = \frac{F_{\text{Benz},in} - F_{\text{Benz},out}}{F_{\text{Benz},in}} \times 100\% = \frac{\sum C_{\text{AR}}}{\sum C_{\text{AR}} + C_{\text{Benz}}} \times 100\% \quad (3.3)$$

Where $F_{\text{Benz},in}$ is the molar flowrate of benzene, C_{AR} is the aromatic products concentration, and C_{Benz} is the benzene concentration.

Similarly, the ethane conversion (X_{C_2}) is:

$$X_{C_2}(\%) = \frac{F_{C_2,in} - F_{C_2,out}}{F_{C_2,in}} \times 100\% = \frac{\sum C_i}{\sum C_i + C_{C_2}} \times 100\% \quad (3.4)$$

where $F_{C_2,in}$ is the molar flowrate of ethane, C_i is the product concentration, and C_{C_2} is the ethane concentration

(d) Selectivity

The selectivity for products formed from ethane feed (such as ethene, propene, propane etc.) is defined as:

$$Sel_{from C_2}(\text{mol.}\%) = \frac{F_D}{F_P} \times 100\% = \frac{C_i}{100 - C_{Benz} - C_{C_2}} \times 100\% \quad (3.5)$$

The selectivity for products formed in the presence of benzene feed (such as EB, iPB) is defined as:

$$Sel_{from Benz}(\text{mol.}\%) = \frac{F_D}{F_P} \times 100\% = \frac{C_i}{\sum C_{AR}} \times 100\% \quad (3.6)$$

where F_D is the molar flowrate of desired product, F_P is the molar flowrate of all of the products formed.

(e) Yield

The reaction yield is the amount of the desired product obtained in a chemical reaction. As a result, the product yield of this reaction is simply the ratio of EB concentration to the total benzene feed:

$$Y(\%) = \frac{F_D}{F_{Benz,in}} \times 100\% = \frac{C_{EB}}{\sum C_{AR} + C_{Benz}} \times 100\% \quad (3.7)$$

(f) Platinum loading

A platinum loading calculation was carried out in order to obtain the amount of metal precursor needed for a desired platinum loading. The amount of platinum precursor, tetraamineplatinum(II)nitrate $\text{Pt}(\text{NH}_3)_4(\text{NO}_3)_2$, needed for PtH-ZSM-5 bifunctional catalyst of 1 wt.% Pt can be calculated as follows:

$$\begin{aligned}\text{Molecular weight of } \text{Pt}(\text{NH}_3)_4(\text{NO}_3)_2 &= 195 + (14 + 3) \times 4 + (14 + 16 \times 3) \times 2 \\ &= 387 \text{ (g/mol)}\end{aligned}$$

Table 3.3. Molecular weight of various components

Components	Molecular weight (g/mol)
Platinum (Pt)	195
Nitrogen (N)	14
Hydrogen (H)	1
Oxygen (O)	16

There is 195g of platinum in 387g of $\text{Pt}(\text{NH}_3)_4(\text{NO}_3)_2$ salt; and, 1g of 1PtHZSM5 catalyst consists 0.99g of H-ZSM5 and 0.01g platinum. Hence, the amount of $\text{Pt}(\text{NH}_3)_4(\text{NO}_3)_2$ required for preparation of 1g of 1PtHZSM5 catalyst is 0.02g.

3.2.3.4. Error analyses

(a) The metal loading of the bifunctional catalysts

As it was describe in the previous section that the Pt was impregnated into H-ZSM-5 zeolite support. The wetness impregnation method was carried out by dropping precursor solution, which was prepared from dissolving the specific amount of platinum precursor into the known amount of water, over the H-ZSM-5 zeolite support using pipette. Lambert and Gonzalez (1998) showed that the impregnated catalysts, which were not washed, yielded similar designed and actual metal loading. As a result, it is assumed that all metal is incorporated into the zeolite support and the metal loading is calculated using Equation 3.8.

$$\%wt \text{ metal} = \frac{\text{Mass of metal (g)}}{\text{Total catalyst mass (g)}} \times 100\% \quad (3.8)$$

The errors in the measured weight of metal and support are given by the accuracy of the scale, in this case ± 0.0001 g.

$$(\Delta \text{Total catalyst mass})^2 = (\Delta \text{mass of support})^2 + (\Delta \text{mass of metal species})^2$$

$$\Delta \text{Total catalyst mass} = (0.0001^2 + 0.0001^2)^{0.5} \approx 0.00014$$

Therefore, the deviation of the metal loading of 1 g of 1PtH-ZSM-5 catalyst can be calculated as follow:

$$\left(\frac{\Delta \%wt \text{ metal}}{\text{Total \%wt metal}} \right)^2 = \left(\frac{\Delta \text{Mass of metal}}{\text{Mass of metal}} \right)^2 + \left(\frac{\Delta \text{Total cat. mass}}{\text{Total cat. mass}} \right)^2$$

$$\left(\frac{\Delta \%wt \text{ metal}}{1 \%wt \text{ metal}} \right)^2 = \left(\frac{0.0001}{0.02} \right)^2 + \left(\frac{0.00014}{1} \right)^2$$

$$\Delta \%wt \text{ metal} \approx 0.005$$

(b) The GC analysis

The gas chromatographic analyses were carried out using Varian CP-3800GC and the errors associated with GC was evaluated by several analyses of the same sample under the same reaction conditions and calculating the standard error (Eq. 3.9).

$$SE = \frac{\sigma}{\sqrt{N}} \quad (3.9)$$

Where $\sigma = \sqrt{\frac{\sum_{i=1}^N (X_i - \bar{X})^2}{N-1}}$, and the factor N-1, rather than N, is required in the

denominator to account for the fact that the parameter \bar{X} has been determined from the data and not independently (Bevington and Robinson, 1992).

The percentage error obtained from deviations of five analyses of the same sample under the same conditions is smaller than $\pm 5\%$ regardless the peak size. Ethane, which consists of around 6200000 peak counts, has an error of $\pm 2\%$ while ethene with approximately 20000 peak counts consists $\pm 4.5\%$ of error. The benzene feed would have

larger error, $\pm 5\%$, compared to ethane feed error, $\pm 2\%$, due to the variation of saturator temperature ($\pm 2^\circ\text{C}$) which is directly affecting the vapour pressure of benzene. Figure 3.12 depicts the benzene conversions obtained from five individual runs, which shows high reproducibility of the experimental data.

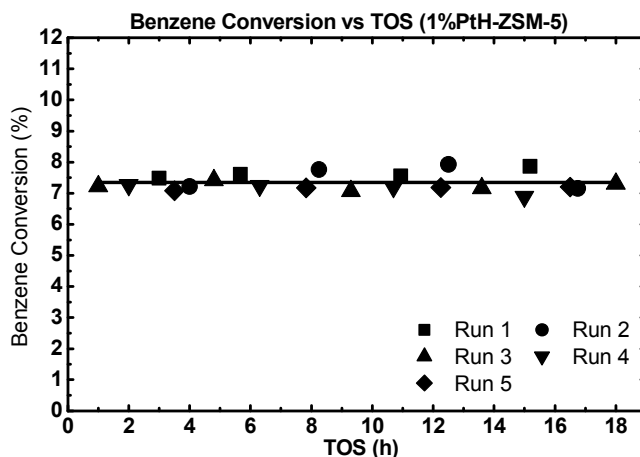

Figure 3.12. Benzene conversion as a function of time on stream (obtained from five individual runs).

(c) The interpretation of graphs

Origin, the graphing and data analysis software, was used to analyse the data points in the graphs by obtaining the gradient of the linear fit, the error in the gradient, the regression coefficient and the residual value. The data points in Figure 3.12 are fitted by linear model and the residual plot is used to check the model (Fig.3.13). A random scatter of the residual plot indicates a good model (Fig.3.13b).

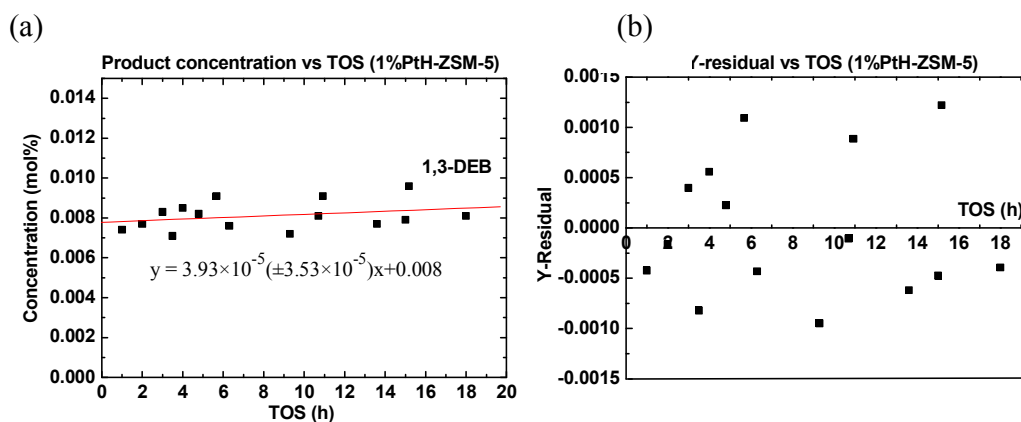

Figure 3.13. (a) Linear fit model of data points, (b) Residual plot of the model.

The data points in figure 3.11 is fitted to polynomial fit, which $R^2 = 0.76$.

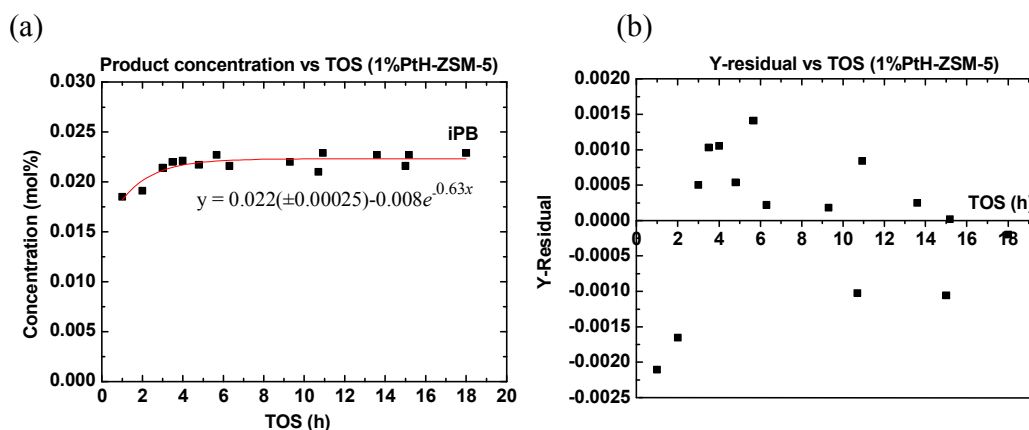

Figure 3.14. (a) Polynomial fit model of data points, (b) Residual plot of the model.

3.3. Catalyst Characterisation

The kinetic studies of benzene alkylation with ethane into EB over catalyst with different compositions were carried out in order to determine the promising catalyst for the reaction. The acidic function optimisation is one part of the project which was carried out by Tanya Vazhnova and the results showed that the catalyst with moderate acidity ($\text{SiO}_2/\text{Al}_2\text{O}_3 = 72$) yielded stable catalyst performance as well as high catalyst activity and selectivity. Then, the catalyst optimisation focused on the Pt species by altering the Pt loading incorporated into ZSM-5 with moderate acidity. The Pt dispersions of the catalysts were determined to understand the effect of Pt loadings on the Pt dispersions which would affect the catalyst effectiveness on the catalytic reaction.

3.3.1. CO chemisorption

The Pt dispersion of PtH-ZSM-5 catalysts was determined by CO chemisorption. The samples were pre-treated under the same conditions as for the kinetic studies to understand the Pt dispersion of PtH-ZSM-5 catalysts when the catalytic reaction started, i.e. the samples were reduced in H_2 for 1 hour prior to the analysis. Hence, CO was selected for the chemisorption to determine the amount of Pt that was segregated from H_2 treatment and to prevent the further reduction if the chemisorption would have been

carried out in H₂ as the Pt is hydrogen sensible. The experiments were carried out by Paul Millington at Johnson Matthey Technology Centre, Sonning Common and the experimental conditions, procedures and result analysis were described.

The sample was reduced by H₂ for 1 hour at 500°C and then a stream of CO is pulsed on the sample once it has reached room temperature. The number of mole of CO adsorbed on the sample was determined by the difference between the initial amount of CO and the amount detected after the adsorption. The area of the adsorbent was calculated by the number of moles of the adsorbed CO and the probe molecular cross-section area. Hence, the metal dispersion of the sample was obtained from the known metal loading of the sample.

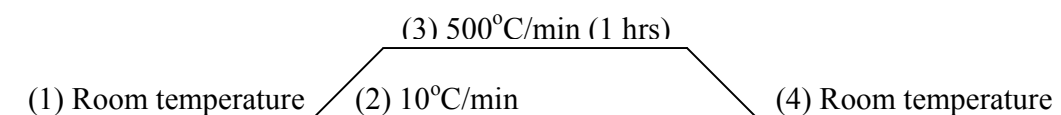

Figure 3.15. Temperature profile of the reduction of PtH-ZMS-5 catalyst in H₂ prior to CO chemisorption.

The temperature was increased at the rate of 10°C per minute (2) to 500°C in H₂ and dwelled for 1 hour at 500°C (3). Then, the temperature was reduced to room temperature (4) and the metal area was determined by CO pulses.

Chapter 4

The Consideration of Thermodynamic Equilibrium and Selection of Reaction Conditions

The underlying idea of this study was to couple ethane dehydrogenation into ethene and hydrogen on metal sites (Eq. 4.1), with benzene alkylation by ethene over the Brønsted acid sites (Eq. 4.2) *via* direct benzene alkylation with ethane into EB and H₂ (Eq. 4.3) using bifunctional zeolite catalysts. These reactions are reversible reactions and would achieve thermodynamic equilibrium, where the rates of forward reactions are equal to the rates of reverse reactions.

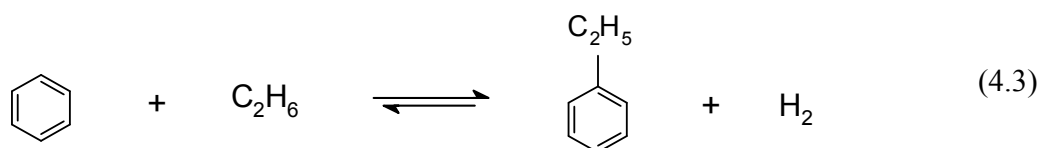
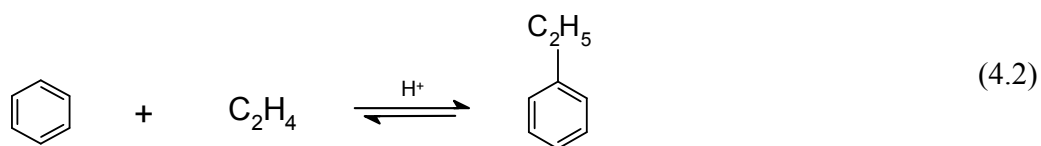

The ethane dehydrogenation into ethene and H₂ is the first step of the benzene alkylation with ethane. The ethene concentration should be maintained low at any point in the reactor to achieve a low rate of the bimolecular ethene dimerisation steps, which are the initial reaction steps in the sequence of alkene oligomerisation and cracking reactions. As described in Chapter 2, the alkene oligomerisation and cracking reactions produce other alkenes, which could be converted into various side products *via* alkylation, aromatisation reactions and coking. Hence, the low ethene concentration would lead to the low concentrations of other alkenes and to suppression of a number of side reactions. Additionally, the low concentrations of alkenes in the reaction mixture would result in the enhancement of the catalyst stability, because alkenes are known as important contributors to the coke formation over zeolite catalysts (Brillis and Manos, 2003 and Ivanova, *et al.*, 1995). The rate of ethane dehydrogenation is affected by

various factors such as reaction temperature, pressure, and catalyst composition. The thermodynamic equilibrium conversion of ethane dehydrogenation could be the fundamental reference in selecting the reaction temperature for the kinetic study of reaction.

The equilibrium constant for heterogeneous reactions involving gases is expressed in terms of partial pressures of the gases, K_p . The K_p of ethane dehydrogenation, benzene alkylation with ethene, and the overall benzene alkylation with ethane, at various reaction temperatures, can be calculated using the enthalpy (ΔH), entropy (ΔS) and specific heat capacity (C_p) data obtained in the literature (Table 4.1). Subsequently, the K_p of the reaction at specific reaction temperature can be used to estimate the equilibrium conversions of benzene ($X_{eq(ben)}$) and ethane ($X_{eq(C2)}$) at that specific reaction temperature.

Table 4.1. Thermodynamics data at 298K (Yaws, 1992).

Components	C_p (J/mol·K)	ΔH (J/mol)	ΔS (J/mol·K)
Ethene	42.9	52400	219.3
Ethane	52.5	-84000	229.2
Benzene	81.67	82880	269.3
EB	128.41	29920	360.63
H ₂	28.8	0	130.7

The standard enthalpy and entropy of the reaction can be calculated using Eq. 4.4 and 4.5.

$$\Delta H_{rxn} (298K) = \Delta H_{products} - \Delta H_{reactants} \quad (4.4)$$

$$\Delta S_{rxn} (298K) = \Delta S_{products} - \Delta S_{reactants} \quad (4.5)$$

The enthalpy and entropy at a specific reaction temperature can be established from the standard enthalpy and entropy of the reaction (Eqs. 4.6 and 4.7). Then, the Gibbs Free

Energy (ΔG) (Eq. 4.8) of the reaction at the specific reaction temperature can be used to estimate the equilibrium constant (Eq. 4.9). The K_p obtained determines the equilibrium conversion for specific feed composition. The thermodynamic equilibrium data calculated for ethane dehydrogenation and benzene alkylation reaction with ethane is presented in Table 4.3 and 4.4, respectively. The equilibrium conversions of ethane dehydrogenation were determined with pure ethane feed, and the feed ratio of benzene alkylation with ethane was 90 vol.% of ethane and 10 vol.% of benzene. The detailed calculations are presented in Appendix 1.

$$\Delta H_{rxn} = \Delta H_{298} + Cp dT \quad (4.6)$$

$$\Delta S_{rxn} = \Delta S_{298} + \frac{Cp}{T} dT \quad (4.7)$$

$$\Delta G_{rxn} = \Delta H_{rxn} - T_{rxn} * \Delta S_{rxn} \quad (4.8)$$

$$\ln K_{a(rx)} = \frac{-\Delta G_{rxn}}{RT_{rxn}} \quad (4.9)$$

where $K_a = \Pi(f_i/f_i^0)$

The standard state for a gas is the ideal-gas state of the pure gas at the standard-state pressure P^0 of 1 bar. Since the fugacity of an ideal gas is equal to its pressure, thus, for gas-phase reaction $f_i/f_i^0 = P_i/P^0$, and $P^0 = 1$ bar.

Table 4.3 and 4.4 show that the enthalpy of ethane dehydrogenation into ethene and hydrogen, and benzene alkylation with ethane into EB and hydrogen increases with increasing reaction temperatures, indicating that both reactions are endothermic reactions. On the other hand, the enthalpy of benzene alkylation with ethene into EB decreases with increasing reaction temperatures showing that it is an exothermic reaction. At reaction temperatures lower than 500°C, the K_p of benzene alkylation with ethane and ethane dehydrogenation reactions are relatively low compared to the K_p of benzene alkylation with ethene (Table 4.2). Hence, the equilibrium conversions at low reaction temperatures are limited by ethane dehydrogenation which gives lowest K_p .

Table 4.2. Thermodynamics equilibrium constants, K_p , at various reaction temperature.

T_{rxn} ($^{\circ}\text{C}$)	$\text{C}_2 = \text{C}_2 + \text{H}_2$	$\text{B} + \text{C}_2 = \text{EB}$	$\text{B} + \text{C}_2 = \text{EB} + \text{H}_2$
	K_p (Pa)	K_p (Pa^{-1})	K_p
250	6.6×10^{-8}	290.03	4.8×10^{-4}
290	6.6×10^{-7}	46.06	8.8×10^{-4}
330	4.9×10^{-6}	9.39	1.5×10^{-3}
370	2.8×10^{-5}	2.32	2.4×10^{-3}
410	1.4×10^{-4}	0.68	3.73×10^{-3}
450	5.68×10^{-4}	0.23	5.52×10^{-3}
490	2.01×10^{-3}	0.09	7.91×10^{-3}
530	6.32×10^{-3}	0.04	1.102×10^{-2}
570	1.79×10^{-2}	0.02	1.498×10^{-2}

Table 4.3. Thermodynamics data of ethane dehydrogenation reaction (Eq. 4.1) on pure ethane feed.

T_{rxn} ($^{\circ}\text{C}$)	ΔH_{rxn} (J/mol)	ΔS_{rxn} (J/molK)	ΔG_{rxn} (J/mol)	$X_{\text{eq}(\text{C}_2)}$ (%)
250	140720.0	131.5998	71893.32	0.03
290	141488.0	133.0148	66600.68	0.08
330	142256.0	134.3326	61253.43	0.22
370	143024.0	135.5658	55855.20	0.53
410	143792.0	136.7245	50409.16	1.20
450	144560.0	137.8173	44918.12	2.40
490	145328.0	138.8512	39384.57	4.40
530	146096.0	139.8322	33810.73	7.70
570	146864.0	140.7656	28198.62	12.50

Figure 4.1 shows that the equilibrium conversion of ethane dehydrogenation increases exponentially with increasing reaction temperatures. This shows that dehydrogenation reactions being highly endothermic are thermodynamically favoured only at very high temperatures (Caeiro, *et al.*, 2006). The equilibrium conversion of pure ethane feed at reaction temperature of 450°C is calculated to be 2.4%, which is in good agreement with the previous experimental work reported by Clark (2005). As highlighted in Chapter 2, the dehydrogenation of ethane takes place on metal sites of the bifunctional catalyst while benzene alkylation reaction occurs on the acid sites. As a result, the amount of active sites (either metal or acid sites) affects the rate-limiting step. If metal sites are sufficient for the dehydrogenation reaction, then the alkylation reaction, which requires acid sites, becomes the rate-limiting step of the overall reaction. On the other hand, dehydrogenation reaction becomes the rate-limiting step when the metal sites are deficient.

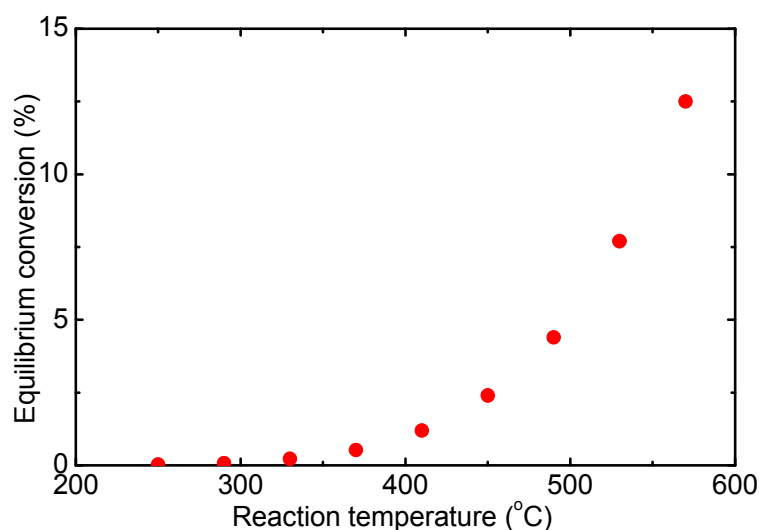

Figure 4.1. Thermodynamic equilibrium conversions of ethane dehydrogenation (Eq. 4.1) as a function of reaction temperature.

Figure 4.2 demonstrates that the equilibrium conversion of benzene alkylation with ethane increases almost linearly with increasing reaction temperatures. The equilibrium conversion of benzene illustrates that under the reaction conditions, at 370°C and ethane/benzene feed molar ratio of 9/1, the conversion of benzene into products will not

exceed 13.6% regardless of the catalyst loadings and the feed flowrates. Additionally, as it is shown in Table 4.4, the ΔG of the benzene alkylation with ethane into EB and hydrogen was found to be larger than zero (positive value). This indicates that the process proceeds spontaneously in reverse direction, i.e. forward reaction of benzene alkylation reaction is disfavoured and the reverse reaction occurs with a higher rate (Yaws, 1992). As a result, low benzene equilibrium conversion is obtained in this reaction, in which the dealkylation reaction dominates when thermodynamics equilibrium approaches.

Table 4.4. Thermodynamic data for the direct benzene alkylation with ethane (Eq. 4.3), feed ratio: 90 vol.% of ethane and 10 vol.% of benzene.

T_{rxn} ($^{\circ}\text{C}$)	ΔH_{rxn} (J/mol)	ΔS_{rxn} (J/molK)	ΔG_{rxn} (J/mol)	$X_{\text{eq(ben)}}$ (%)
250	36224.0	5.7897	33195.97	6.3
290	37145.6	7.4877	32930.01	8.5
330	38067.2	9.0691	32598.51	11.0
370	38988.8	10.5489	32205.83	13.6
410	39910.4	11.9394	31755.78	16.5
450	40832.0	13.2507	31251.73	20.0
490	41753.6	14.4914	30696.67	23.0
530	42675.2	15.6687	30093.27	26.5
570	43596.8	16.7887	29443.94	30.0

The feed ratio will affect the thermodynamic equilibrium conversion (Caeiro *et al.*, 2006). In ethane dehydrogenation into ethene and hydrogen, the equilibrium conversion of ethane will be higher at lower ethane feed partial pressure since the K_p remains constant. The benzene alkylation with ethane into EB with a higher ethane/benzene molar ratio, i.e. higher ethane and lower benzene partial pressures leads to a low equilibrium conversion of ethane but higher benzene equilibrium conversion. It was

calculated that the equilibrium conversion for the transformation of an equimolar mixture of benzene and ethane into EB is only about 5% at 370°C. The equilibrium conversion of benzene alkylation with ethane increases to 9.2% when the ethane/benzene feed ratio increases to 4:1 and, further increase in ethane/benzene feed ratio to 9:1 has led to 13.6% of equilibrium conversion of benzene.

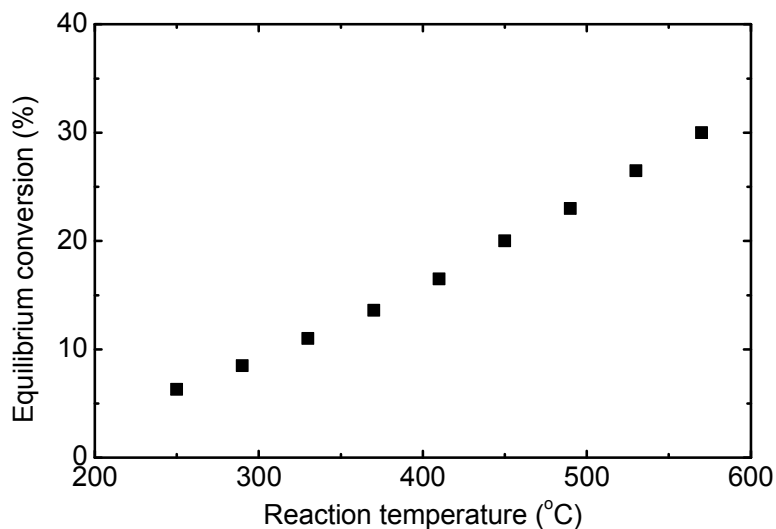

Figure 4.2. Thermodynamic equilibrium conversions of benzene in benzene alkylation with ethane into EB and hydrogen (Eq. 4.3).

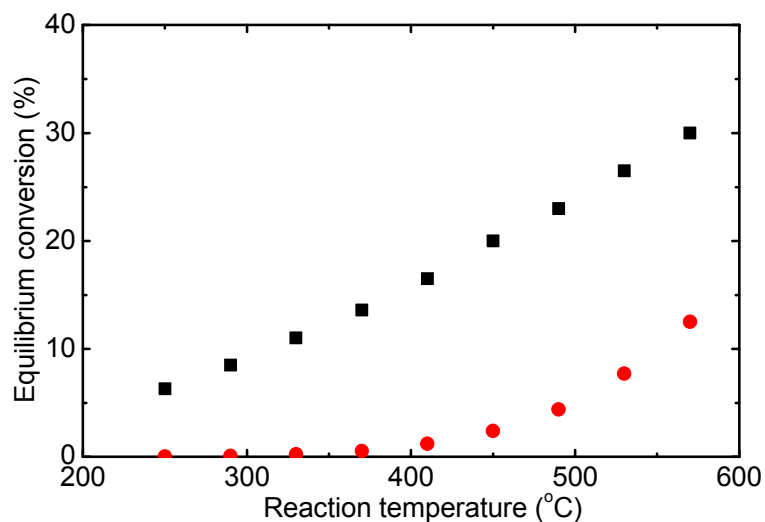

Figure 4.3. Thermodynamics equilibrium conversions of (■) benzene in benzene alkylation with ethane and (●) ethane in ethane dehydrogenation reaction.

Figure 4.3 shows that the equilibrium conversion of ethane in ethane dehydrogenation increases exponentially in the temperature range of 370 to 590°C, while the equilibrium conversion of benzene in benzene alkylation with ethene into EB increases linearly with increasing reaction temperature. This suggests that large amount of ethane would be dehydrogenated into ethene and hydrogen at high temperature. The ethene could be alkylated by benzene, forming EB, or be converted *via* secondary reactions, such as oligomerisation, cracking and aromatisation reactions.

On the other hand, the transformation of benzene with ethene into EB is an exothermic reaction. Table 4.2 shows that the K_p of benzene alkylation with ethene into EB decreases with increasing temperature which indicates that the conversion of benzene with ethene into EB is not favourable at high temperature. Hence, only specific amount of ethene would be alkylated by benzene forming EB even though large amount of ethene is produced from the dehydrogenation reaction, i.e. the formation of EB becomes less favourable at high temperature. The ethene could remain as ethene in the product mixture and be converted into considerable amount of side products, such as alkenes, alkanes and aromatics, reducing the selectivity of EB in all products. Based on the thermodynamic equilibrium data, it is predicted that a further increase in the reaction temperature would lead to higher conversion but various side products could be formed due to high ethene concentration, thus reducing the EB selectivity.

The ethane dehydrogenation equilibrium conversions at low reaction temperatures are below 1%. However, the thermodynamic equilibrium is a dynamic phenomenon and, therefore, it would be possible to by-pass the thermodynamic limitations for ethane dehydrogenation reaction by trapping ethene molecules with benzene *via* alkylation reaction into EB. In this case, the overall efficiency of benzene alkylation with ethane should depend on the rates of the dehydrogenation (Eq. 4.1) and alkylation reactions (Eq. 4.3). The rates of dehydrogenation and alkylation reactions could be adjusted by the nature and number of metal sites and by the number of Brønsted acid sites, respectively.

In conclusion, the catalytic reaction of benzene alkylation with ethane forming EB was carried out in a temperature range of 290-490°C to determine the most optimum reaction temperature. At these temperatures, the equilibrium ethane dehydrogenation conversions into ethene are relatively low which should ensure low ethene concentration at any point in the reactor, and eventually lead to low rates of secondary side reactions, including coke formation.

Chapter 5

Effect of Reaction Temperature on Benzene Alkylation with Ethane into Ethylbenzene

It was described in Chapter 4 that the catalyst stability could be enhanced by maintaining the low concentration of ethene in the reaction mixture, since alkenes are known as the major sources of the coke formation over zeolite catalysts. The low ethene concentration at any point in the reactor could be achieved by the low reaction temperature. This would suppress a number of side reactions such as the bimolecular ethene dimerisation, oligomerisation and cracking reactions. As a result, the preliminary investigation of benzene alkylation with ethane over PtH-ZSM-5 bifunctional catalyst was carried out at 370°C. The equilibrium conversion of ethane dehydrogenation into ethene and hydrogen (for pure ethane feed) at this temperature was calculated to be around 0.55% (Table 4.3). This chapter starts with discussion of the preliminary investigation of benzene alkylation with ethane into EB. Then the selection of the temperature range for further investigation is considered. This is followed by detailed discussion on the effects of temperature on catalyst performances and product distributions.

5.1. Preliminary investigation of benzene alkylation with ethane

The preliminary investigation was carried out to examine the feasibility of selective and stable alkylation of benzene with ethane into EB over Pt-containing ZSM-5 catalyst. Kato, *et al.* (2001) demonstrated benzene alkylation with ethane over various Pt-loaded ZSM-5 catalysts (Pt content between 3 and 8.8 wt.%). A catalyst with lower metal content but similar catalyst performance would be more commercially attractive. Hence, Pt-containing (1 wt.%) ZMS-5 bifunctional catalyst, defined as 1PtH-ZSM-5, was selected for the preliminary investigation. Lukyanov and Vazhnova (2008a and 2008b) established that the benzene alkylation with ethane into EB over PtH-ZSM-5 catalysts of zeolite of moderate ($\text{SiO}_2/\text{Al}_2\text{O}_3 = 72$) yielded stable catalyst performance as well as high catalyst activity and selectivity. Kato, *et al.* (2001) showed that the C_8 aromatics yield was almost constant when the ethane/benzene ratio was above 5. It was suggested that the drop of C_8 aromatics yield at ethane/benzene ratio of lower than 5 is due to the coverage of Pt active site, needed for the ethane dehydrogenation, by benzene at a higher benzene partial pressure. As a result, the catalytic reaction was carried out at ethane/benzene feed ratio of 9, and the benzene partial pressure was maintained by

keeping the benzene feed in the saturator at 20°C. According to Kato, *et al.* (2001), the C₈ aromatics yield was expected to be similar to ethane/benzene ratio of 5.

5.1.1. Establishment of the reaction steady state

Figure 5.1 shows that the catalyst under different loadings (under reaction conditions) experiences a transient period before reaching a stable performance. The first GC analysis was carried out at time on stream of 12 minutes, and the benzene conversion within the first 4 hours of the reaction increased and decreased over high (200 and 500 mg) and low (50 mg) catalyst loadings, respectively. The change of benzene conversion at the beginning of the reaction is known as the transient period. Each catalyst loading achieves a specific benzene conversion after a particular period and remains at this conversion until the end of the catalytic experiment. The catalyst performance is considered stable after the transient period, during which no change in benzene conversion was observed.

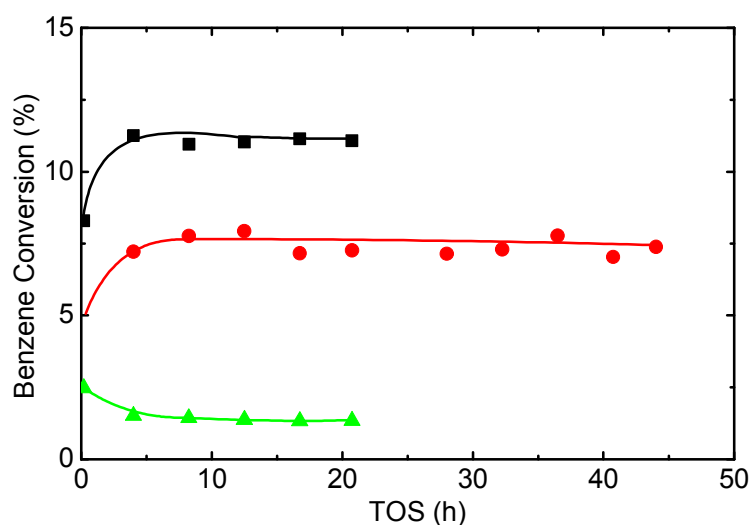

Figure 5.1. Effect of time on stream on benzene conversions over (■) 500 mg, (●) 200 mg and (▲) 50 mg of 1PtH-ZMS-5 catalyst at 370°C.

It is well known in the industrial application of catalysis that after the reduction procedure a catalyst needs to be treated by the flowing gaseous reactants for a period of time, before steady catalytic performance is reached. This is called the ‘activation

procedure' and could happen also in a laboratory reactor. Arsenova-Hartel *et al.* (1999) highlighted that the catalytic reaction could begin with a transient period, during which the conversion increases until a certain steady state is reached. Rylander (1967) pointed out that hydrogenation process over ruthenium catalysts yielded an induction period especially at low pressure. This induction period is the time required to achieve the maximum hydrogenation rate. Rylander (1967) claimed that the induction period can be eliminated by hydrogen reduction for one hour and the length of this period has no relation to the activity of the catalysts. Unfortunately, the above statement was not proven or explained further.

Figure 5.1 shows that the benzene conversion over 200 mg of PtH-ZSM-5 catalyst rose from 5 to 7.2 %, while the benzene conversion over 50 mg of catalyst dropped from 2.5 to 1.5 % during 4 h on stream. This observation suggests that the stability of benzene alkylation with ethane into EB over PtH-ZSM-5 catalyst is improved at high catalyst loading. The catalysts are loaded in the vertically connected cylindrical reactor as described in Chapter 3. It is clear that the gaseous feed flowing into the vertical reactor would be in contact first with the uppermost layer of the catalyst and this layer of catalyst would be the first catalyst layer to catalyse the reactions. Hence, it could be considered as the primary catalyst layer that would be consumed due to catalyst deactivation (Jackson, 2006). The deactivation of the next catalyst layer might start spontaneously and the rate of deactivation of the second catalyst layer could be slower than the first catalyst layer. The complete deactivation of the second catalyst layer would occur only after the complete deactivation of the primary catalyst layer. It is known that chemisorbed hydrogen species could reduce the level of coke formed and thus reduces deactivation. The adsorbed hydrogen species would be formed initially *via* the reduction process by hydrogen prior to the start of the reaction and later from the hydrogen produced from ethane dehydrogenation. It is proposed that rapid deactivation would be observed in the primary catalyst layer as the hydrogen concentration is at the lowest level at the top of the reactor. Then, the rate of deactivation was predicted to decrease gradually along each catalyst layer by the adsorbed hydrogen species, which are gradually formed in dehydrogenation, oligomerisation, and aromatisation reactions.

Hence, more hydrogen would be formed at the second catalyst layer compared to the first catalyst layer. As a result, large catalyst loading would be able to resist deactivation much better because it consists of many catalyst layers.

It was described in Chapter 3 that a thermocouple is located in the reaction very close to the catalyst to get accurate readings of the catalyst temperature. When the reaction started, highly endothermic dehydrogenation reaction is taking place, followed by the exothermic benzene alkylation reaction. The highly endothermic dehydrogenation reaction takes place in the first catalyst layer and heat is absorbed from the surroundings of that catalyst layer. The temperature of the surroundings (the following catalyst layer) could be lower than the targeted reaction temperature. As a result, the reactions take place at this catalyst layer could be lower than at the targeted reaction temperature. Hence, the larger catalyst layer (loading) could lead to the larger temperature gradient across the catalyst. Once the thermocouple in the furnace detected the drop of temperature, the heating coil in the furnace would restore the heat. At the beginning, benzene could be converted at lower reaction temperature because the heat is being absorbed by the highly endothermic dehydrogenation reaction, i.e. lower benzene conversion could be observed. After some time, heat being restored and benzene alkylation and consecutive reactions would take place at the targeted reaction temperature leading to higher benzene conversion. Catalytic experiments with the thermocouple inserted into the catalyst layer instead of lying on the surface of the catalyst layer (Fig. 5.2) were carried out to verify this proposal. The results showed that the temperature gradient within the catalyst layer was about 1-2°C. The temperature gradient within the catalyst layer is too small to affect the change in the catalyst activity, i.e. benzene and ethane conversions. As a result, the temperature gradient across the catalyst layer is negligible and all reactions occur at constant reaction temperature along the catalyst layer. Hence, the change in benzene and ethane conversions during the transient period is not due to the temperature gradient across the catalyst layer.

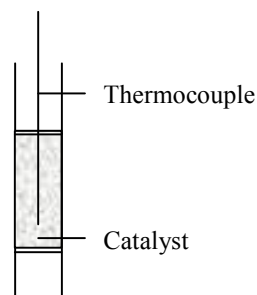

Figure 5.2. Schematic of the reactor set-up for the examination of temperature gradient in the catalyst layer.

Arsenova-Hartel *et al.* (1999) observed the transient period in the disproportionation of EB into benzene and DEB (Eq. 2.11e) and suggested that transient period is due to the establishment of the sorption equilibrium of the reactants. On the onset of the experiment the yield of DEB is lower than the yield of benzene, though on the basis of the stoichiometry, equimolar quantities of the two products should be expected. The deficit of the product DEB in the gas phase during the transient period of the reaction is, caused, at least to some extent, by the enriched adsorption of DEB in the zeolite pores due to its preferential sorption, compared to EB and benzene. The simultaneous analysis of the concentration of the reactants in the gas phase and in the zeolite pores during the EB disproportionation showed higher concentration of the DEB in the catalyst. Additionally, it was observed that the concentration of EB in the gas phase decreases with time on stream and that of the product DEB increases until the stationary stage is reached. Arsenova-Hartel *et al.* (1999) carried out kinetic studies of disproportionation of EB as well as the direct comparison of the sorption properties of the products and the feed in the large and medium pore zeolites. The results have shown that the difference in the sorption constants of benzene, EB and DEB diminishes with increasing reaction temperature and decreasing zeolite pore size. A shorter transient period is observed at higher temperatures (320°C) and over the zeolite with the narrower pores (H-ZSM-5).

The nature of transient period is a complex interplay of a great variety of factors, the effects of which are not easy to separate and detailed analyses are required in order

to understand fully the transient period (Arsenova-Hartel *et al.*, 1999). The main objective of this project is to develop a new catalytic reaction pathway for benzene alkylation with ethane into EB at relatively low reaction temperature. Hence, the reasons for the occurrence of the transient period and the factors affecting the length of the transient period will not be studied further in this project. As a result, the further catalytic analyses of benzene alkylation with ethane into EB would be carried out at the steady state of the reaction. Preliminary catalytic experiments were carried out to determine the time required to achieve the reaction steady state (Fig. 5.3).

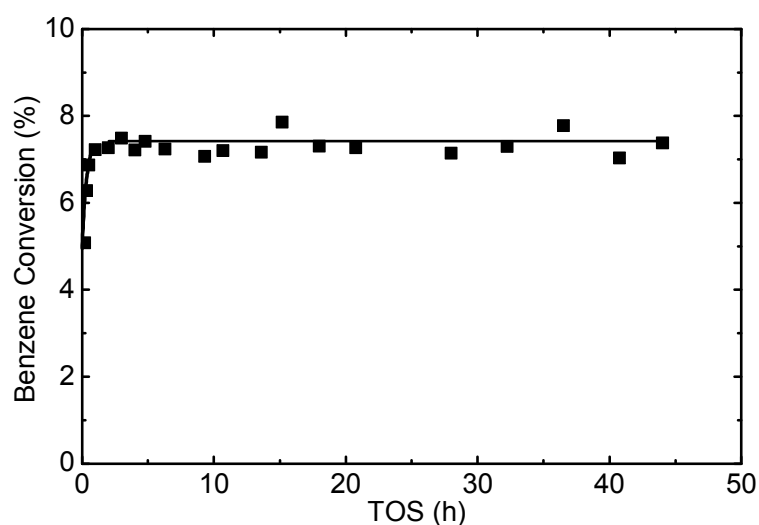

Figure 5.3. Effect of time on stream on benzene conversion for benzene alkylation with ethane at 370°C over 1PtH-ZSM-5 catalyst (WHSV = 7.2 h⁻¹).

Figure 5.3 depicts that the benzene conversion was 5% at 12 minutes on stream and increased to 6.8% after 30 minutes on stream. The benzene conversion rose to 7.2% after 1 hour on stream and remained stable up to 48 hours. Figure 5.4 shows that the ethane conversion increased from 1 to 1.1% within 1 hour on stream and maintained at 1.1% up to 48 hours on stream. Figure 5.5 depicts the effect of time on stream on the main products concentrations of benzene alkylation with ethane, i.e. ethene, hydrogen and EB. The concentrations of hydrogen, EB and ethene experienced the transient period, in which the concentrations increased or decreased with time on stream, before the steady state was reached. The hydrogen concentration dropped from 1.3 to 1.1 mol.% over the first hour of the reaction and maintained at the same level, while the EB

concentration increased from 0.45 to 0.55 mol.% during transient period. Slight increase in ethene concentration, from 0.2 to 0.3 mol.%, was observed after 1 hour on stream.

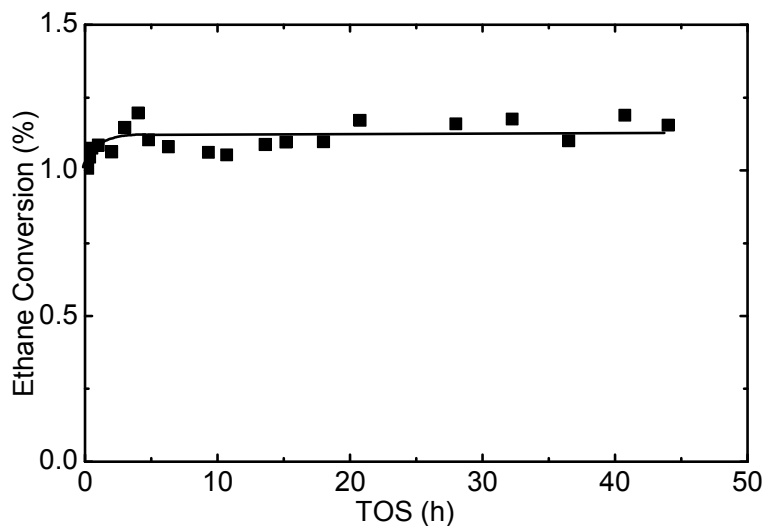

Figure 5.4. Effect of time on stream on ethane conversion for benzene alkylation with ethane at 370°C over 1PtH-ZSM-5 catalyst (WHSV = 7.2 h⁻¹).

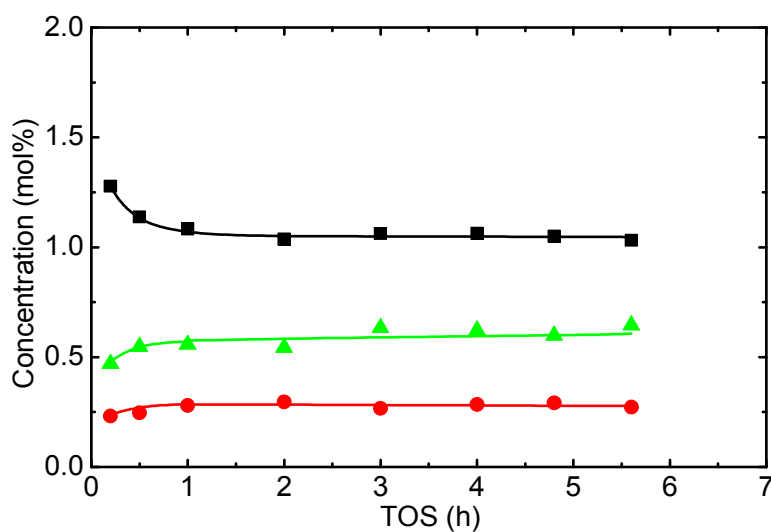

Figure 5.5. Effect of time on stream on the concentrations of (■) hydrogen, (▲) EB and (●) ethene at 370°C over 1PtH-ZSM-5 catalyst (WHSV = 7.2 h⁻¹).

Based on the results shown in Figures 5.3, 5.4 and 5.5, it is concluded that the benzene alkylation with ethane at 370°C achieved steady state after 1 hour on stream. It should be noted that the experimental data discussed in the following sections was obtained during steady state of the reaction.

5.1.2. Performance of the catalyst at 370°C

An effective catalyst should provide excellent performances in terms of the catalyst stability, activity and the selectivity to the desired products. Stable catalyst performance of benzene alkylation with ethane into EB over 1PtH-ZSM-5 was observed at 370°C. Indeed, no changes were noticed in benzene and ethane conversions during nearly 50 h on stream (Fig. 5.6). The 7% benzene conversion and 1% ethane conversion at 370°C remained stable up to nearly 50 h. Additionally, the selectivity of ethene and EB in all carbon containing products maintained at 30 mol.% and 63 mol.%, respectively, during this time (Fig. 5.7). The summation of the selectivity of ethene and EB in all carbon containing products gives 93 mol.% and this reveals that ethene and EB are the main products of benzene alkylation with ethane into EB over bifunctional catalyst. Lukyanov and Vazhnova (2008a) suggested that ethene is produced from ethane dehydrogenation over metal sites (Eq. 5.1) and EB is formed from the benzene alkylation with ethene on acid sites (Eq. 5.2).

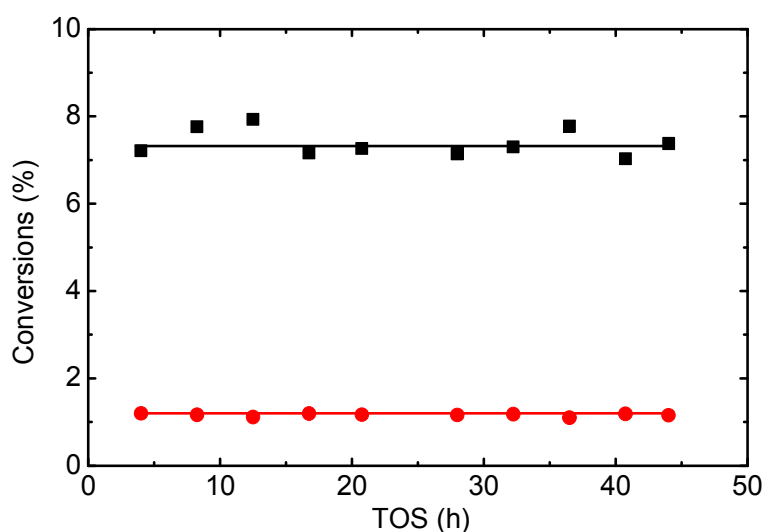

Figure 5.6. Effect of time on stream on (■) benzene and (●) ethane conversions at 370°C over 1PtH-ZSM-5 catalyst (WHSV = 7.2 h⁻¹).

The analyses of the effects of contact time on the benzene and ethane conversions at 370°C were carried out after 20 hours on stream, i.e. during steady state period. The feed flowrate was changed after 20 hours on stream to obtain different contact times for

the analysis of catalyst activity at steady state. Figure 5.8 demonstrates the effect of contact time on ethane and benzene conversions during the reaction steady state.

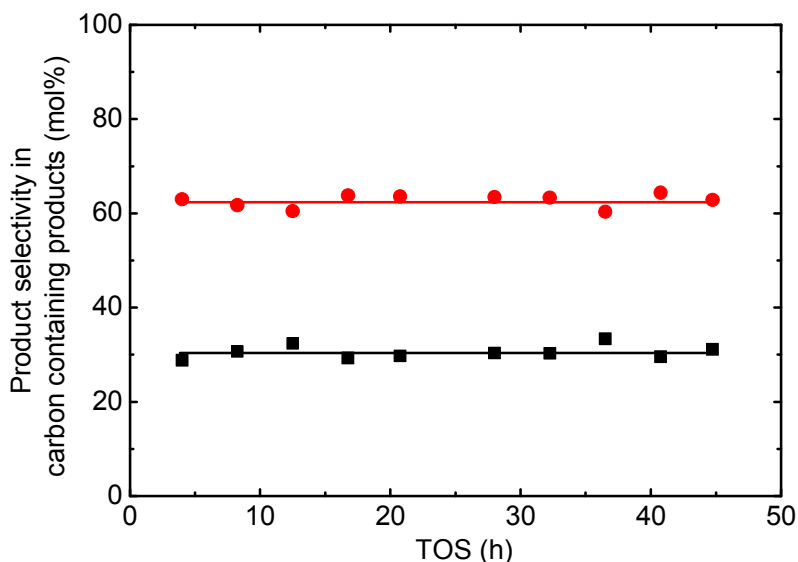

Figure 5.7. Effect of time on stream on (■) ethene and (●) EB selectivity in all carbon containing products at 370°C over 1PtH-ZSM-5 catalyst (WHSV = 7.2 h⁻¹).

At zero contact time, i.e. no contact between the feed gas and the catalyst, no ethane could be converted, and hence, the extrapolation of the ethane conversion curve to the origin is possible. Then, the ethane conversion increases with the contact time and reaches the plateau, after which any further increase in contact time leads to minor or no change in the conversion. Figure 5.8 shows that the ethane conversion increased from 0.35 to 1.5% over the initial 0.32 h of contact time and achieved 1.75% at 0.65 h of contact time. Linear correlation between the conversion and the contact time could be expected if ethane is converted in irreversible reactions. However, non-linear correlation is observed in Figure 5.8, indicating that the reverse reaction is taking place, reproducing ethane, and thus, suppressing the ethane conversion.

The benzene conversion rose to 8.8% over the first 0.15 h of contact time at 370°C, in which the benzene is transformed linearly as only forward reaction is taking place. After that the curve reaches a plateau indicating that the benzene conversion become

less dependent on the contact time (Fig. 5.8). This indicates that benzene is transformed reversibly and the reverse reaction, dealkylation of EB into ethene and benzene, takes place at high contact time, limiting the benzene transformation. The maximum benzene conversion is around 12.5% (Fig. 5.8), which is very close to the thermodynamic equilibrium conversion of 13.6% at 370°C (Table 4.4).

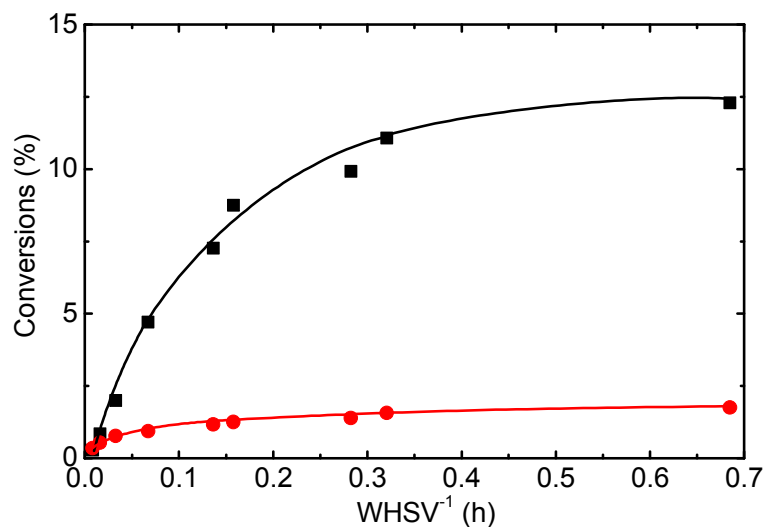

Figure 5.8. Effect of contact time on (■) benzene and (●) ethane conversions over 1PtH-ZSM-5 catalyst at 370°C.

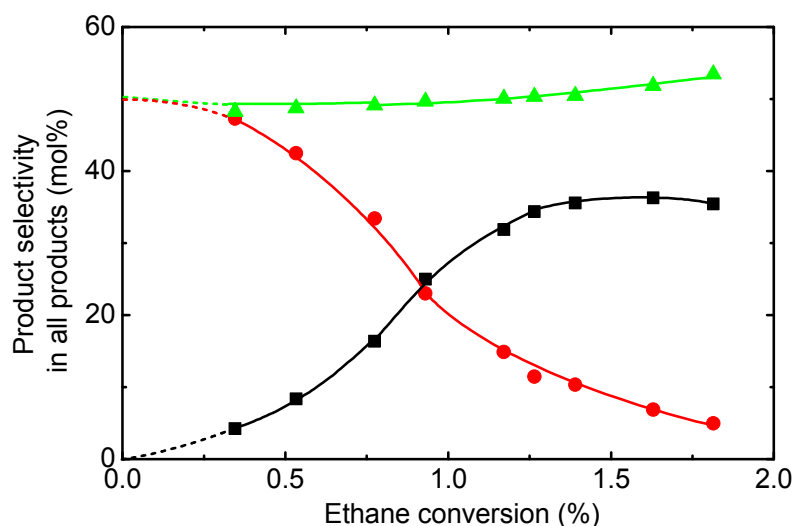
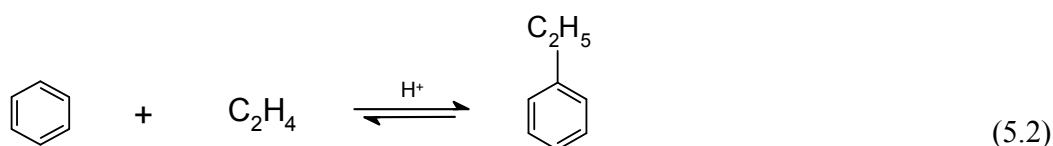

Figure 5.9. Effect of ethane conversion on (■) EB, (▲) hydrogen and (●) ethene selectivity in all products over 1PtH-ZSM-5 catalyst at 370°C.

Figure 5.9 shows that the selectivities of ethene and hydrogen were very close to 50 mol.% at very low ethane conversion. The equimolar amounts of ethene and hydrogen were observed once ethane started to transform, i.e. at low ethane conversion. This demonstrates that the hydrogen and ethene are the primary products that are formed from the dehydrogenation of ethane. The selectivity of EB approaches the origin, and this indicates that EB is formed from the consecutive reaction steps, the benzene alkylation with ethene.

Hydrogen, which selectivity was around 50 mol.%, was produced in the stoichiometric amounts corresponding to Eqs. (5.1) and (5.2).



The benzene alkylation with ethane involves two consecutive reaction steps. Firstly, ethane is dehydrogenated into equimolar amounts of ethene and hydrogen, followed by the alkylation of benzene with ethene forming EB. Hence, hydrogen which is not consumed in the consecutive reaction steps should have 50 mol.% selectivity at any point of ethane conversion. The drop of ethene selectivity with ethane conversion (Fig. 5.9) is due to the consumption of ethene in the consecutive reaction step, i.e. benzene alkylation with ethene into EB, and hence, the rise of EB selectivity with ethane conversion is observed.

The preliminary investigation established the principle of the highly selective and stable benzene alkylation with ethane over bifunctional zeolite catalyst at 370°C. The experimental data indicates that the low ethane conversion at 370°C has led to the low ethene concentration in the reactor which eventually enhanced the catalyst stability by suppressing many side reactions, including coke formation. The results demonstrate that the EB formation proceeds *via* two consecutive reaction steps: (i) the dehydrogenation

of ethane into ethene over Pt sites and (ii) benzene alkylation with ethene over acid sites. Additionally, the catalyst demonstrates tremendous stable performance up to nearly 48 h on stream and more than 90 mol.% of EB selectivity in aromatic products at 12.5% of benzene conversion. This impressive catalyst performance in terms of activity, stability and selectivity at 370°C has led to the further optimisation in the reaction temperature and catalyst composition.

5.2. Selection of the reaction temperature range

The preliminary investigation of benzene alkylation with ethane into EB at 370°C, described above, showed excellent catalyst performance, in terms of activity, selectivity and stability. Lukyanov and Vazhnova (2008a) suggested that the low reaction temperature limits the formation of ethene (and other alkenes) and, as a consequence, suppresses various side reactions, including the coke formation. However, no attempt was made in that work to investigate benzene alkylation with ethane at other temperatures. The next two sections will focus on the in-depth investigation of benzene alkylation with ethane into EB over 1PtH-ZSM-5 catalyst at various temperatures. The main aim of this investigation was to understand the effect of the reaction temperature on the reaction pathways and the catalyst performance, and to establish the optimum temperature for the reaction.

The selection of the temperature range was carried out based on the thermodynamic equilibrium of ethane dehydrogenation into ethene and hydrogen (Eq. 5.1) and the benzene alkylation with ethane into EB and hydrogen (Eq. 5.3).

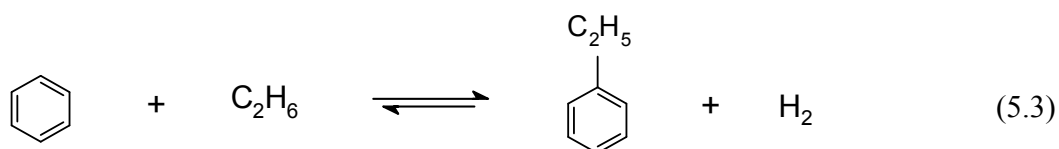

It was discussed as detailed in Chapter 4 that the equilibrium ethane dehydrogenation conversions into ethene are relatively low at 290-490°C. This should ensure low ethene concentration at any point in the reactor, and, eventually, lead to low rates of secondary side reactions. Additionally, the overall equilibrium conversions at

these temperatures are within 8.5 to 23%. Hence, the kinetic studies of benzene alkylation with ethane into EB were carried out first at low (290°C) and high (490°C) temperatures to ensure that the selected temperature range, based on thermodynamic equilibrium conversions, is feasible. The catalyst performance and products distributions at low (290°C) and high (490°C) temperatures will be investigated and compared with the moderate (370°C) temperature to understand the effect of high and low temperatures on benzene alkylation with ethane over 1PtH-ZSM-5 catalyst.

5.2.1. Catalyst performance at low (290°C), moderate (370°C) and high (490°C) temperatures

Figure 5.10 shows very stable catalyst performance at 290°C and 370°C, practically no changes was observed in benzene conversions during 45 h on stream. Lower catalyst stability was observed at 490°C, where the benzene and ethane conversions drop from 16 to 13% (Fig. 5.10) and from 6.2 to 5.5% (Fig. 5.11), respectively, over nearly 45 h on stream. Stable catalyst performance was observed at 290°C (conversions remained constant up to 45 h on stream), but the catalyst yielded 2.5% of benzene conversion and 0.25% of ethane conversion, showing that the catalyst activity was relatively low, at this temperature.

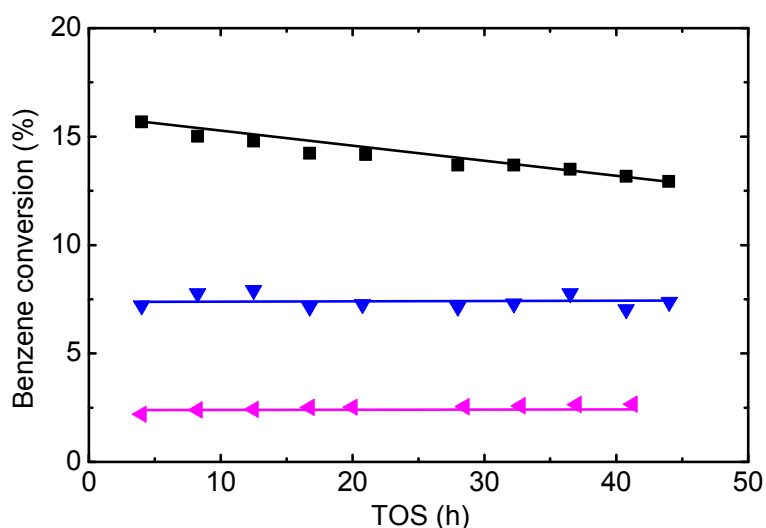

Figure 5.10. Effect of time on stream on benzene conversion at (■) 490°C, WHSV = 7.2 h⁻¹, (▼) 370°C, WHSV = 7.2 h⁻¹, and (◄) 290°C, WHSV = 1.5 h⁻¹.

On the other hand, high catalyst activity, i.e. high benzene and ethane conversions, but lower catalyst stability was observed at 490°C (Figs 5.10 and 5.11). Figure 5.10 clearly shows that at the same WHSV, 490°C yielded about 15% of benzene conversion while the benzene conversion was only 7.5% at 370°C, showing (as expected) that the 1PtH-ZSM-5 catalyst is considerably more active at higher reaction temperature in benzene alkylation with ethane into EB.

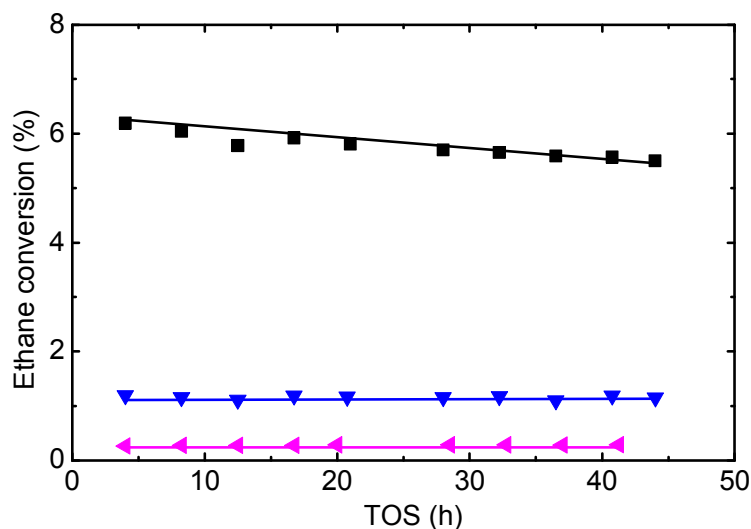

Figure 5.11. Effect of time on stream on ethane conversion at (■) 490°C, WHSV = 7.2 h⁻¹, (▼) 370°C, WHSV = 7.2 h⁻¹, and (◄) 290°C, WHSV = 1.5 h⁻¹.

The drop in benzene and ethane conversions at 490°C (Figs. 5.10 and 5.11) indicates that the catalyst is less stable at 490°C and that the rate of deactivation at 490°C is more significant. The catalyst deactivation at high reaction temperature (490°C) could be due to the higher rate of coke formation at this temperature compared to this rate at the lower temperatures. The high conversion of ethane at 490°C will lead to high ethene concentration and, as a consequence, the higher rate of the bimolecular ethene dimerisation steps, which are the initial reaction steps in the series of alkene oligomerisation and cracking reactions. This series of side reactions will produce large amount of alkenes (e.g. propene and butenes) and aromatics. The high concentration of alkenes in the reaction mixture would result in the decrease in the catalyst stability because alkenes are important contributors to the coke formation over zeolite catalysts (Brillis and Manos, 2003; Ivanova, *et al.*, 1995).

Figure 5.12 demonstrates no changes in ethene and EB selectivities up to 45 h on stream at 370°C. It should be noted that the ethene and EB selectivities at 370°C (Fig. 5.12a) and 490°C (Fig. 5.12b) are obtained at different conversions. The relatively low conversions at 370°C have led to low EB selectivity at 0.13 h of contact time. On the other hand, at the same contact time, the relatively high EB selectivity at 490°C is achieved at high benzene and ethane conversions, i.e. 17.5 and 6.1%, respectively.

At 490°C, the EB selectivity increased slightly with TOS while the ethene selectivity remained constant over 45 h on stream. The rise in EB selectivity with TOS at 490°C could be associated with dramatic decrease in the selectivities to methane, toluene, TEBs and other aromatics (Fig. 5.13b). The changes in the product selectivities at 490°C are probably related to the coke formation that does not affect considerably the ethane dehydrogenation and benzene alkylation reactions but causes the preferential deactivation of catalyst sites that are responsible for the formation of methane, toluene and heavy aromatics. The low equilibrium conversion of ethane dehydrogenation at 290 and 370°C has led to the low ethane conversion (Fig. 5.11), which suppresses alkene oligomerisation, cracking and aromatisation reactions, and hence, enhancing the catalyst stability. Figures 5.12 and 5.13 show that the changes in product selectivities become insignificant after about 20 h on stream indicating the deceleration in the rate of coke formation at longer TOS. Hence, the further analyses will be focused on experimental data that obtained at TOS of 21 h in order to discuss the stabilised product distributions.

The analysis of the effects of contact time on the benzene and ethane conversions at 490, 370, and 290°C was carried out after 20 hours on stream, i.e. during steady state period. Figures 5.10 and 5.11 clearly depict that the ethane and benzene conversions increased with reaction temperatures, as ethane dehydrogenation into ethene and hydrogen, and overall benzene alkylation with ethane into EB are endothermic reactions (see Fig. 4.3).

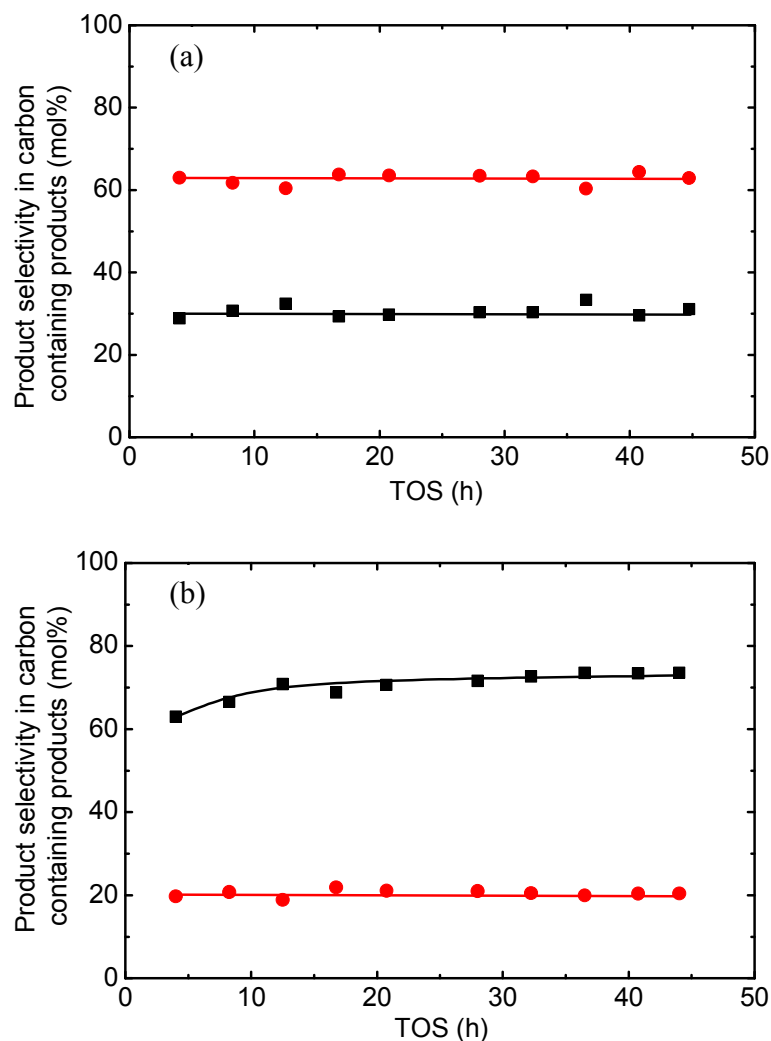

Figure 5.12. Effect of time on stream on (■) EB and (●) ethene selectivity in carbon containing products at (a) 370°C and (b) 490°C, WHSV = 7.2 h⁻¹.

Relatively high ethane conversion was achieved at 490°C due to the higher equilibrium conversion of ethane dehydrogenation reaction at this temperature. It was discussed in Chapter 4 that ethane dehydrogenation is highly endothermic, and the equilibrium conversion increases exponentially at reaction temperature higher than 400°C (Fig. 4.3). As a result, large amount of ethane is dehydrogenated into ethene and would be converted further *via* benzene alkylation and side reactions, such as oligomerisation, cracking, aromatisation etc.

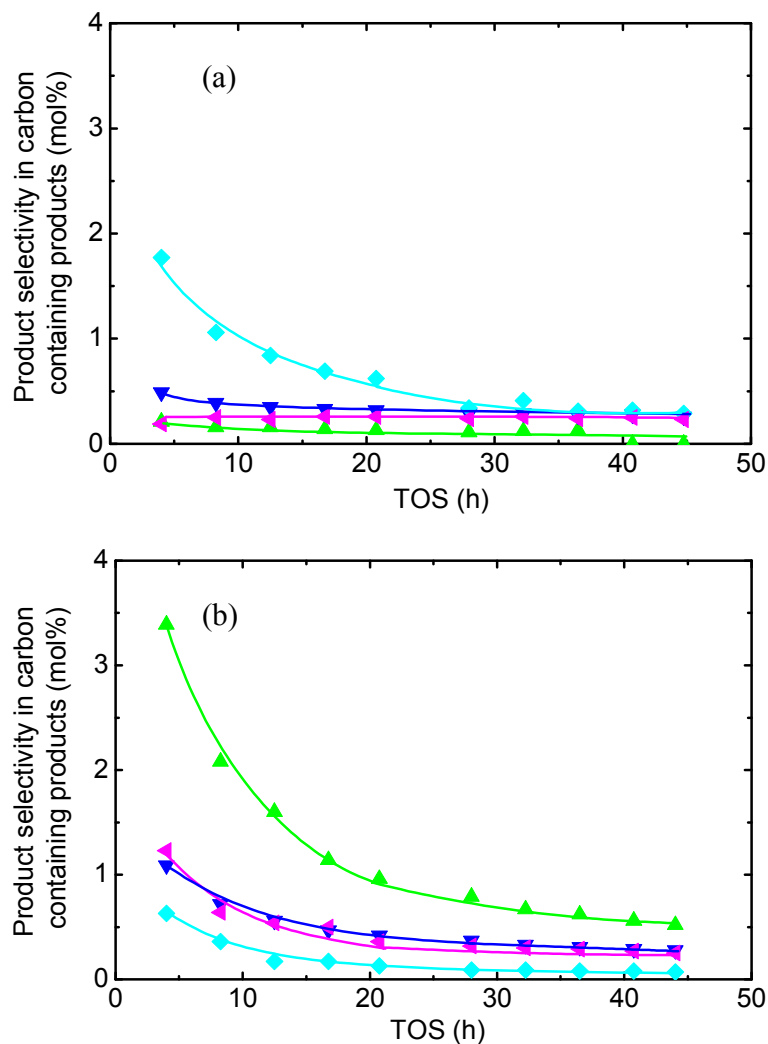

Figure 5.13. Effect of time on stream on (▲) methane, (▼) toluene, (◆) TEBs and (◀) other aromatics selectivity in carbon containing products at (a) 370°C and (b) 490°C, $WHSV = 7.2 \text{ h}^{-1}$.

At 490°C, the transformation of ethane attained 7% at the contact time of 0.65 h, which is higher than the maximum equilibrium conversion of ethane dehydrogenation, 4.4%. Ethene, which is produced from the primary reaction, i.e. ethane dehydrogenation into ethene and hydrogen, would be consumed by the consecutive reactions, such as alkylation of benzene with ethene forming EB. The consumption of ethene by the consecutive reactions would lead to the drop of the ethene concentration in the gas phase and hence, the forward ethane dehydrogenation reaction will be favoured. The

continuous removal of ethene, i.e. consumption *via* secondary reactions, would push the forward ethane dehydrogenation reaction, and hence, achieve ethane conversion higher than the equilibrium conversion of ethane dehydrogenation.

At 490°C, ethane conversion increased significantly from 2 to 5% over 0.1 h of contact time (Fig. 5.14), and further increase in the contact time from 0.1 to 0.65 h has risen the ethane conversion from 5 to 7%. At 290°C, the ethane conversion was 0.17% at the contact time of 0.15 h and rose to 0.27% when 4 times amount of catalyst was loaded ($WHSV^{-1} = 0.64$ h). Additionally, Figure 5.14 depicts that the ethane conversion at 290°C was lower than 0.5% over 0.65 h of contact time, showing that the catalyst yielded very low activity at this reaction temperature. At low contact time, forward ethane dehydrogenation reaction is favourable and produces large amount of ethene and hydrogen, leading to dramatic rise in ethane conversion. Then, the reverse hydrogenation of ethene which reproduces ethane, starts to take place when high concentration of ethene is formed in the reaction mixture. The effect of contact time on ethane conversion becomes less significant when the reverse reaction starts taking place. The reverse reaction is competing with the secondary reactions as the former hydrogenates ethene into ethane and the later convert ethene into various products, such as EB, propane, and propene, etc.

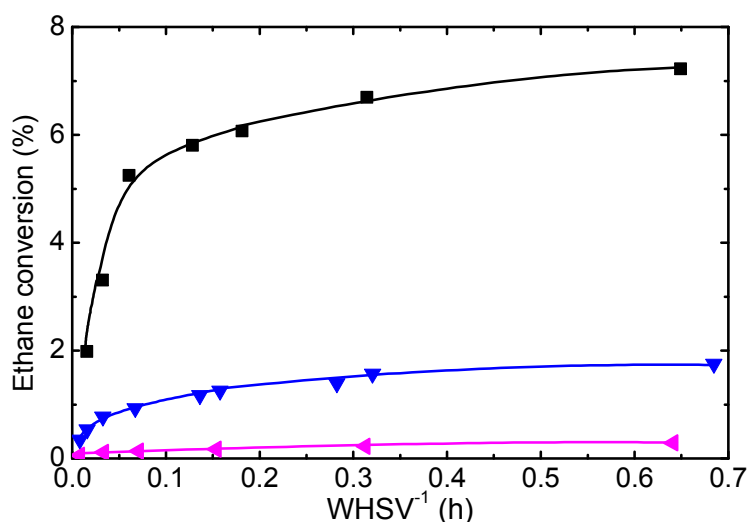

Figure 5.14. Effect of contact time on ethane conversion at (■) 490, (▼) 370, and (◄) 290°C.

Figure 5.15 demonstrates clearly that benzene conversions increased with increasing reaction temperatures. As it was described in Chapter 4 and discussed in section 5.1.2, the conversion of ethane into ethene and hydrogen is the first step of benzene alkylation with ethane, then benzene reacts with ethene, i.e. the product of primary step, forming EB. Although benzene alkylation with ethene is an exothermic reaction, the conversion of benzene is limited by the overall reaction (benzene alkylation with ethane), which is an endothermic reaction. Because of the endothermic nature of the overall reaction, the equilibrium benzene conversion increases with reaction temperature.

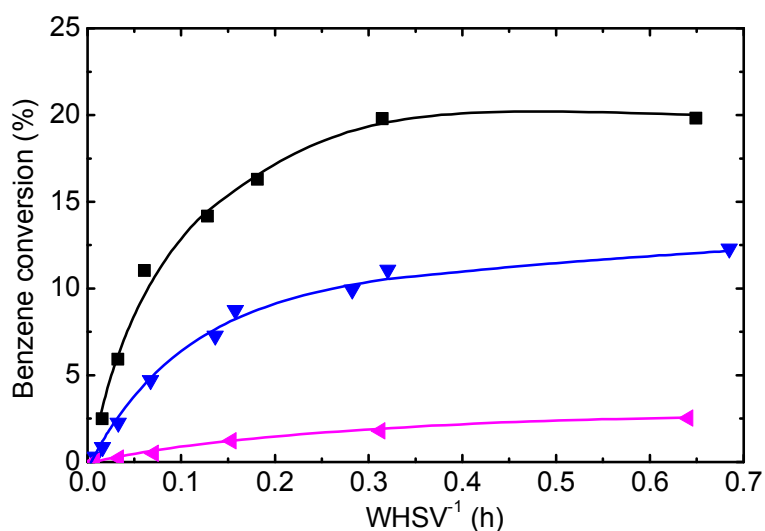

Figure 5.15. Effect of contact time on benzene conversion at (■) 490, (▼) 370, and (◄) 290°C.

The benzene conversions at all (high, moderate and low) temperatures are dependent initially on the contact time. Then, the curves nearly reach a plateau indicating that the benzene conversions become less dependent on the contact time (Fig. 5.15). For example, at 490°C, the benzene conversion increased dramatically over the initial 0.15 h of contact time, i.e. from 2.5 to 15%, then the transformation of benzene became less dependent on the contact time, i.e. benzene conversion rose from 15 to 20% when the contact time increased from 0.15 to 0.65 h. This indicates that benzene is transformed reversibly and that the reverse reaction, dealkylation of EB into ethene and

benzene, takes place at high contact time suppressing the transformation of benzene with ethene into EB. Figure 5.15 depicts that linear correlation was observed at low contact time ($WHSV^{-1} < 0.1$ h), showing that the forward reaction (alkylation reaction) is more favourable than the backward reaction (dealkylation reaction). At high contact time, more benzene is converted into products and these products, such as EB and iPB, could undergo backward dealkylation reaction and suppress the transformation of benzene.

The selectivity of the desired products is one of the most important criteria in determining the efficiency of a catalyst in the reaction. Figure 5.16a shows at 290°C that the selectivity of EB in aromatic products was more than 97 mol.% at 3% of benzene conversion. Traces of iPB (Fig. 5.16b) and DEBs (Fig. 5.16c) selectivities in aromatic products were observed at 290°C, and practically no tertiary products, such as TEBs, was detected at this temperature (Fig. 5.17).

The EB selectivity approached 100 mol.% at low benzene conversion suggesting that at low benzene conversion, EB is the only aromatic product being formed. Then, the EB selectivity dropped slightly to 97 mol.% at 2% of benzene conversion. The drop of EB selectivity is associated with the formation of the secondary products, such as iPB and DEBs. Figures 5.16b and 5.16c depict the selectivities of iPB and DEBs in aromatic products started to be observed at 2% of benzene conversion. This indicates that the formation of main secondary products is taking place after 2% of benzene is converted. The EB selectivity decreased further at higher benzene conversion when the secondary products are formed in larger amounts. At the same time, the formation of the tertiary products, such as TEBs and toluene (Figs. 5.17a and 5.17b) start taking place.

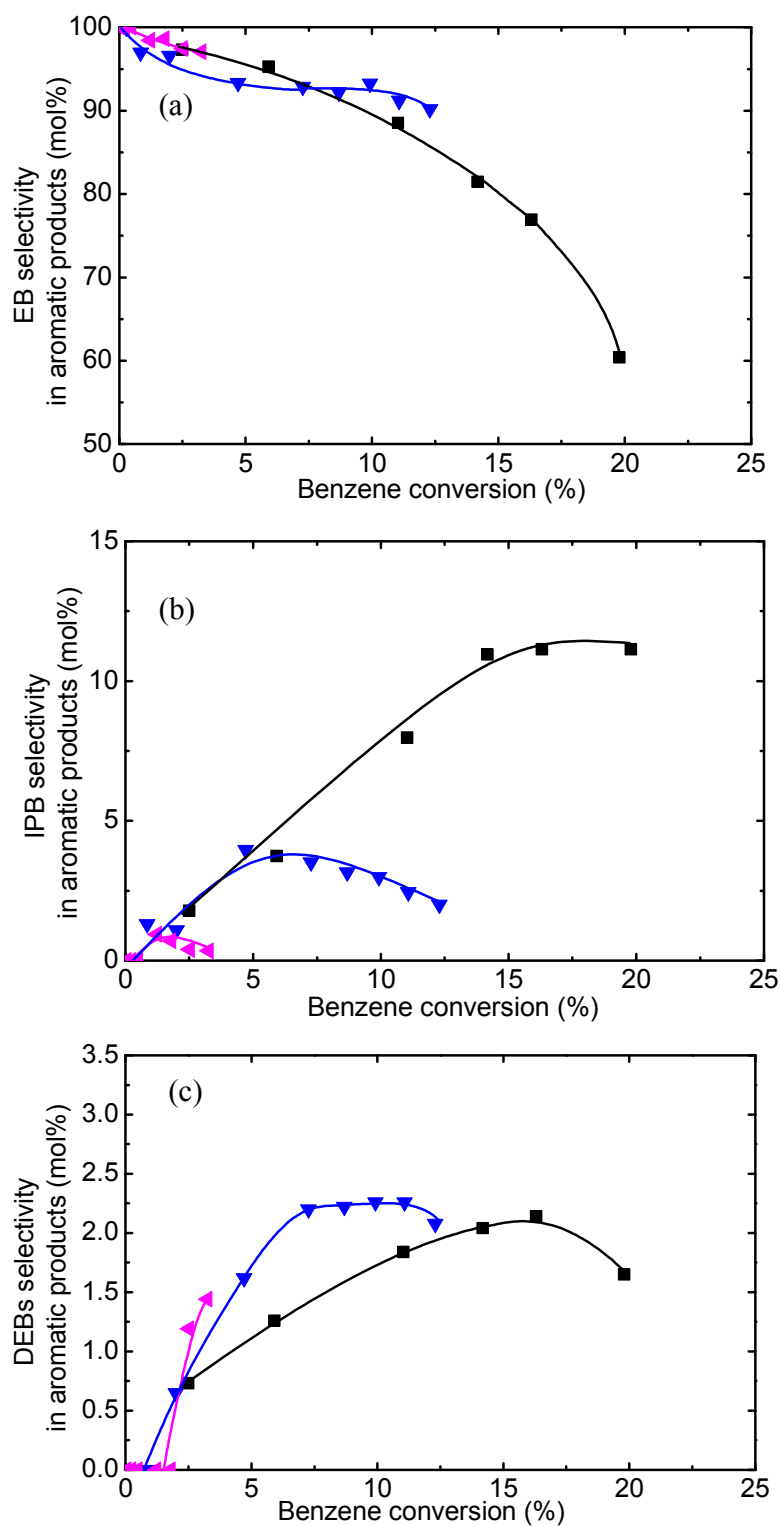

Figure 5.16. Effect of benzene conversion on (a) EB, (b) iPB, and (c) DEBs, selectivities in aromatic products at (■) 490, (▼) 370, and (◄) 290°C.

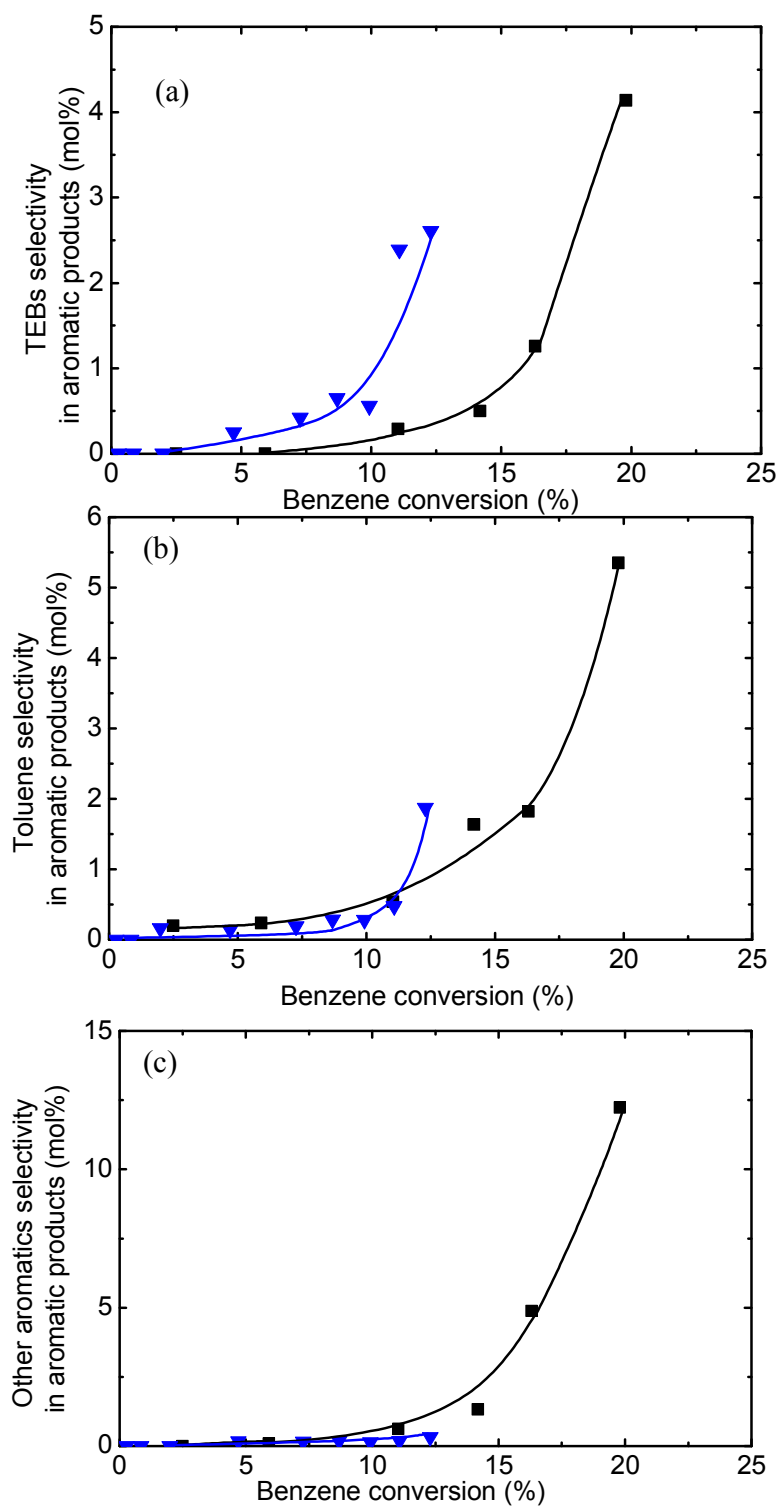

Figure 5.17. Effect of benzene conversion on (a) TEBS, (b) toluene, and (c) other aromatics selectivities in aromatic products at (■) 490 and (▼) 370°C. These products were not observed at 290°C.

The drop of EB selectivity in aromatic products with increasing of benzene conversion is more dramatic at 490°C and can be identified into two distinct regions. The first region includes benzene conversions up to about 10%, where EB selectivity in aromatic products is above 90 mol.% and decreases slowly with rising of benzene conversion (Fig. 5.16a). Similarly to the reaction carried out at 370°C, the drop of EB selectivity in the first region results mainly from the rising iPB and DEBs selectivities (Figs. 5.16b and 5.16c). In the second region, i.e. at benzene conversions above 10%, a significant drop in EB selectivity is observed (Fig. 5.16a) indicating that formation of other aromatic products, which consumed benzene, is taking place. The main aromatic products that were formed in large amounts at benzene conversion above 10% are TEBs (Fig. 5.17a), toluene (Fig. 5.17b), xylenes, ethyltoluene and other aromatics (Fig. 5.17c). The later included different alkylbenzenes and naphthalene (Lukyanov and Vazhnova, 2008b). Figures 5.16 and 5.17 reveal higher iPB, TEBs, toluene and other aromatics selectivities in aromatic products at 490°C, indicating that the transformation of benzene into aromatic side products is more favourable at higher reaction temperature. On the other hand, similar DEBs selectivity was observed at 370 and 490°C (Fig. 5.16c). This could be due to the transformation of DEBs into TEBs, *via* alkylation of DEB with ethene, is more pronounced at 490°C. Hence, higher TEBs selectivity was observed at 490°C (Fig. 5.17a).

Figures 5.10-5.15 demonstrate clearly that benzene alkylation with ethane into EB over 1PtH-ZSM-5 catalyst yielded high stability but low activity at 290°C. The catalyst is stable up to 45 h on stream at 290°C (Figs. 5.10 and 5.11) and the maximum ethane and benzene conversions are 0.5 and 2.5%, respectively (Figs. 5.14 and 5.15). The low feed conversions would lead to high capacity of recycled feed, reducing the process efficiency (Degnan *et al.*, 2001). Because of the extremely low activity at 290°C, further detailed analysis of the effect of temperature on benzene alkylation with ethane will not focus on this temperature.

5.2.2. Product distribution and reaction pathways at moderate (370°C) and high (490°C) temperatures

Section 5.2.1 discussed that the catalyst performance of 1PtH-ZSM-5 in benzene alkylation with ethane into EB at low (290°C), moderate (370°C) and high (490°C) temperatures. The results show that the catalyst was stable at 290°C, but very low catalyst activity was observed. On the other hand, relatively high catalyst activity was observed at 490°C but the catalyst was less stable, i.e. benzene and ethane conversions decreased over 50 h on stream. In addition to the effect of temperature on the catalyst performance, the effect of temperature on the reaction pathways and product distribution will be investigated in detail in this section for 370 and 490°C.

Figure 5.18 shows the effect of ethane conversion on ethane, hydrogen and EB selectivities in all products. These results demonstrate clearly that EB is the secondary reaction product and that it is not formed *via* direct alkylation of benzene with ethane over 1PtH-ZSM-5 catalyst. Additionally, Figure 5.18 indicates that ethene and hydrogen are the primary products, which are formed from ethane dehydrogenation reaction, at 490°C. Similar reaction pathway was observed at 370°C. Figure 5.9 demonstrates that ethene and hydrogen selectivities could be extrapolated to the y-axis and equimolar amounts of ethene and hydrogen (50 mol.%) were observed at low ethane conversion. Additionally, the extrapolation of EB selectivity indicates that EB could be formed after the transformation of ethane into ethene and hydrogen (Fig. 5.9). As a result, it is concluded that benzene alkylation with ethane into EB over PtH-ZSM-5 catalyst proceeds *via* similar reaction pathways at 370 and 490°C (Figs. 5.9 and 5.18).

Figure 5.19 supports further the above suggestion. The hydrogen and ethene concentrations could be extrapolated to the origin at 370 and 490°C (Figs. 5.19a and 5.19b), indicating that ethene and hydrogen are the initial products formed once the reactants are in contact with the catalyst. Figure 5.19c depicts that the concentrations of EB are observed at contact time of 0.03 and 0.05 h for 490 and 370°C, respectively. This reveals that at 370 and 490°C the benzene alkylation with ethane into EB over PtH-

ZSM-5 catalyst proceeds *via* two consecutive reactions: (i) ethane dehydrogenation into ethene and hydrogen (Eq. 5.1) and (ii) benzene alkylation with ethene (Eq. 5.2).

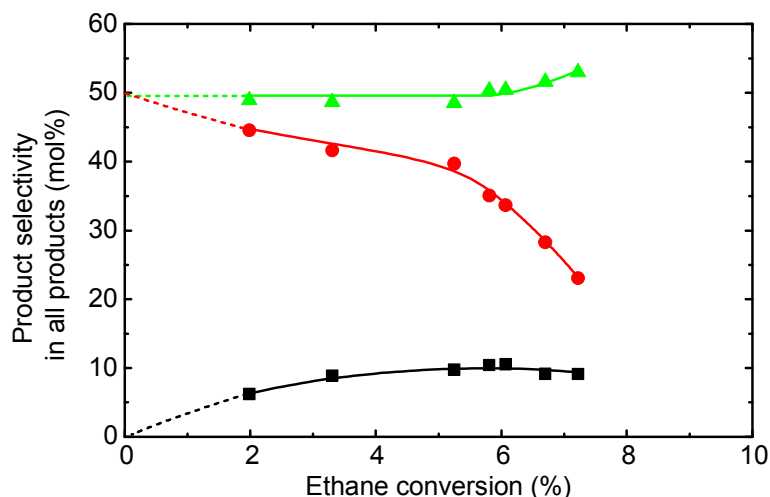

Figure 5.18. Effect of ethane conversion on (■) EB, (▲) hydrogen and (●) ethene selectivity in all products over 1PtH-ZSM-5 catalyst at 490°C.

Figure 5.18 shows that the selectivity of hydrogen remained at 50 mol.% up to 6% of ethane conversion and started to increase slightly to 53 mol.% at higher ethane conversion. The rise of hydrogen selectivity at higher ethane conversion could be due to the reactions which produce hydrogen. Aromatisation reaction could be one of such reactions, which are more favourable at higher ethane conversion (Nguyen *et al.*, 2006). The dramatic drop in ethene selectivity at ethane conversion higher than 6% is in agreement with the above suggestion (Fig. 5.18). The selectivity of EB remains nearly constant even though the ethene selectivity dropped significantly at ethane conversion higher than 6%, indicating that the formation of EB is not the only reaction consuming ethene. At high ethane conversion, ethene, which in this case is formed from ethane dehydrogenation, is likely to be consumed in large amount by dimerisation of ethene, which is the initial reaction step in the sequence of alkene oligomerisation, aromatisation and cracking reactions (Lukyanov and Vazhnova, 2008a). Figure 5.9 illustrates the ethene selectivity decreases while the EB selectivity rises with increasing ethane conversion at 370°C. This implies that ethene is converted mainly into EB *via* benzene alkylation with ethene at 370°C.

EB is formed *via* similar reaction pathways: ethane dehydrogenation into ethene and hydrogen and followed by benzene alkylation with ethene into EB, at 370 and 490°C. Figure 5.19 shows different product distributions at these temperatures, at which higher ethene and hydrogen concentrations were observed at 490°C (Figs. 5.19a and 5.19b). This observation supports further the analysis of thermodynamic equilibrium conversion of ethane dehydrogenation in Chapter 4. It was illustrated clearly in Chapter 4 that ethane dehydrogenation is highly endothermic, and the equilibrium conversion increases exponentially at reaction temperature higher than 400°C (Fig. 4.2). Hence, large amount of ethene and hydrogen could be formed from ethane dehydrogenation at 490°C. The ethene could be converted further into EB, *via* benzene alkylation with ethene, and other light alkanes and alkenes, such as propane, propene, butanes, butenes, etc., *via* oligomerisation, aromatisation and cracking reactions (Nguyen *et al.*, 2006).

Figures 5.20b and 5.20c depict that propane and propene concentrations are higher at 490°C and this could be due to the high ethene concentration at 490°C (Fig. 5.19b), which induces the formation of other light alkenes and alkanes. The drop of ethene concentration at high contact time (Fig. 5.19b) could be mainly due to the consumption of ethene by benzene alkylation with ethene into EB and the secondary reactions which are favourable at higher contact time. Additionally, higher methane concentration was observed at 490°C (Fig. 5.20a).

Figure 5.19c demonstrates that the curve gradient at 490°C is steeper at low contact time compared to at 370°C, indicating that the initial rate of EB formation is higher at 490°C. At the later temperature, the EB concentration remains almost unchanged from 0.13 to 0.65 h of contact time. EB could be converted, at high contact time, by the dealkylation reaction and the consecutive reactions, which includes polyalkylation, isomerisation, transalkylation, and disproportionation, etc. (Moreau *et al.*, 2002).

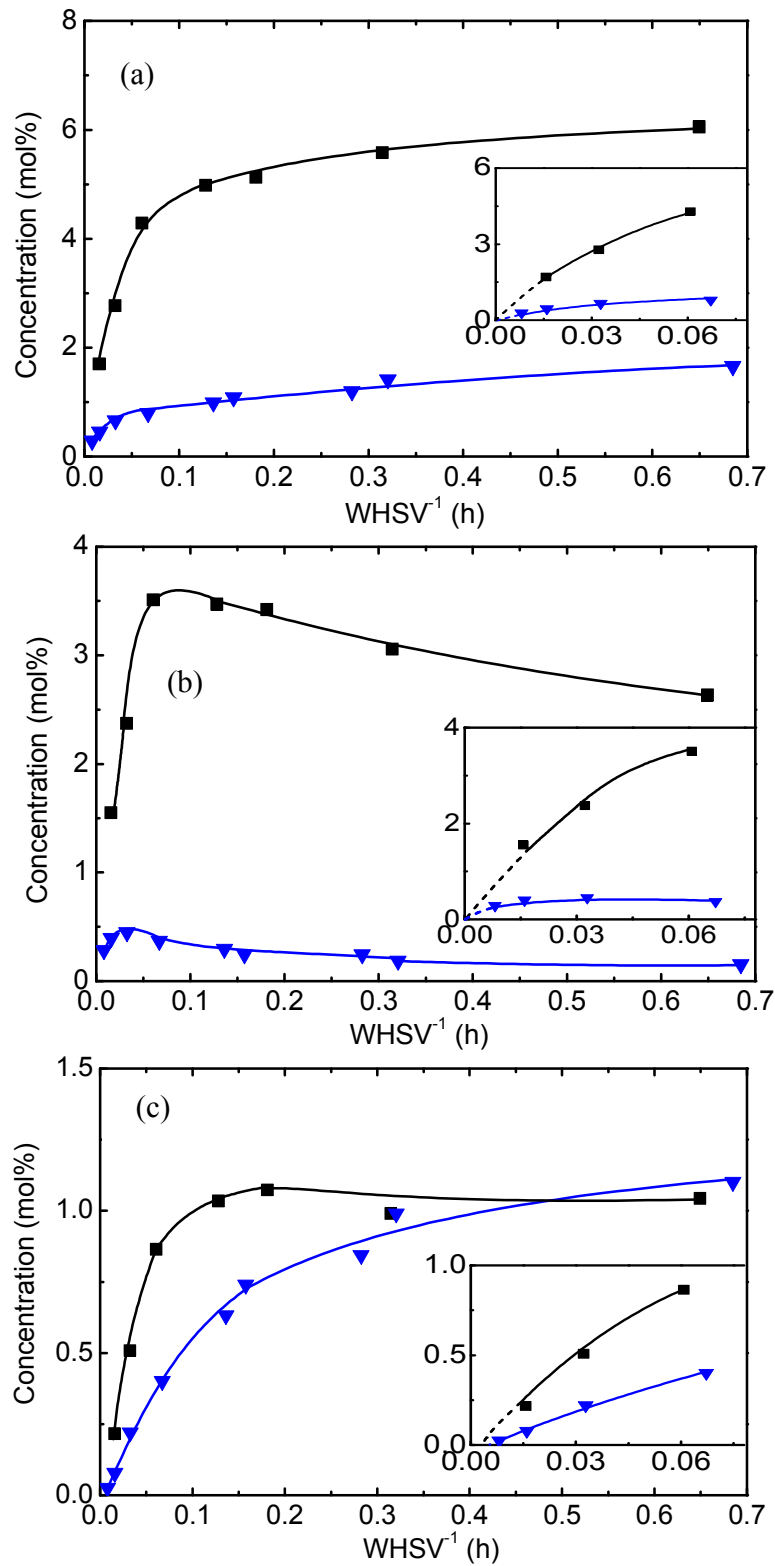

Figure 5.19. Effect of contact time on (a) H₂, (b) ethene, and (c) EB concentrations at (■) 490 and (▼) 370°C.

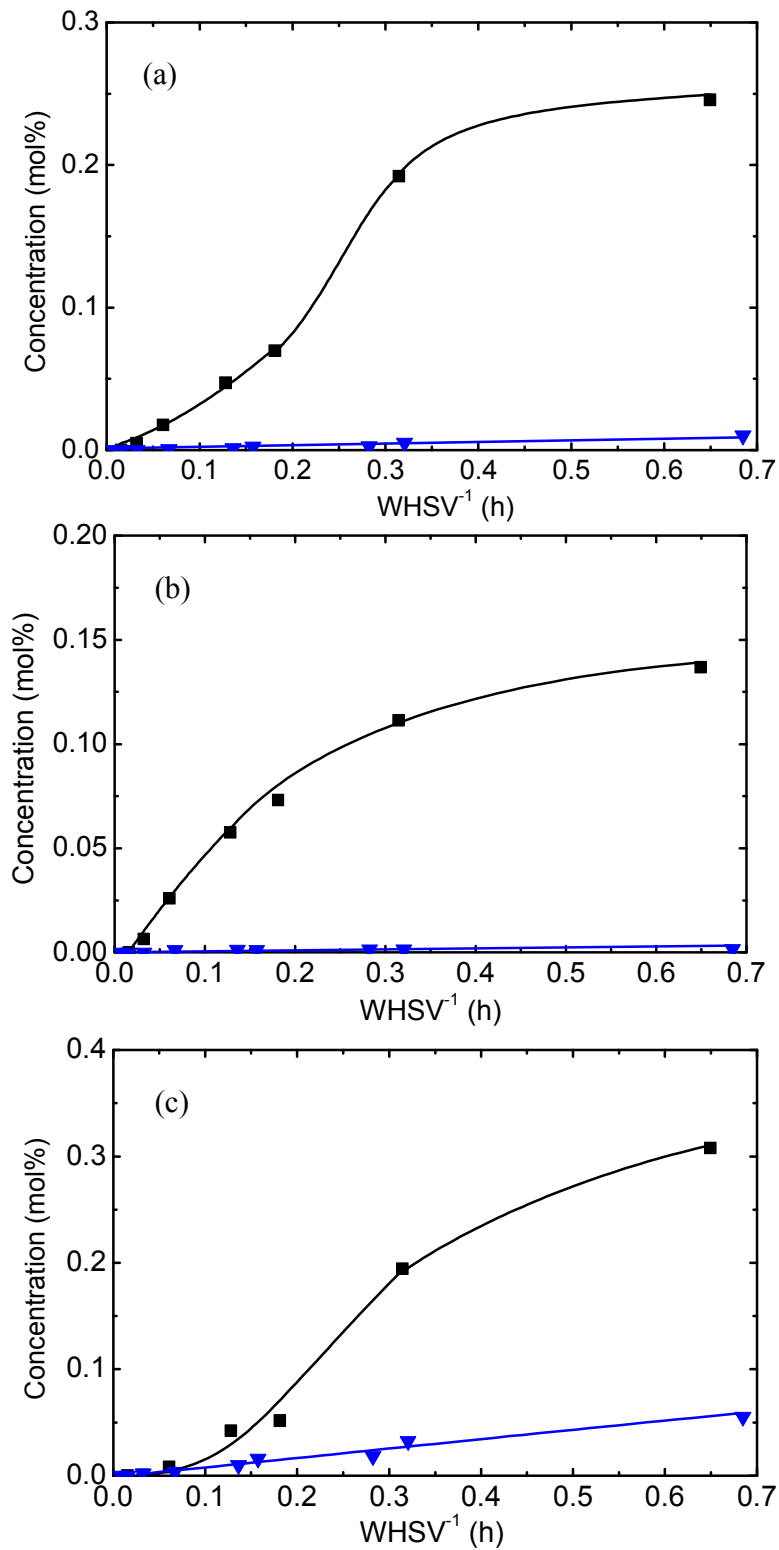

Figure 5.20. Effect of contact time on (a) methane, (b) propene, and (c) propane concentrations at (■) 490 and (▼) 370°C.

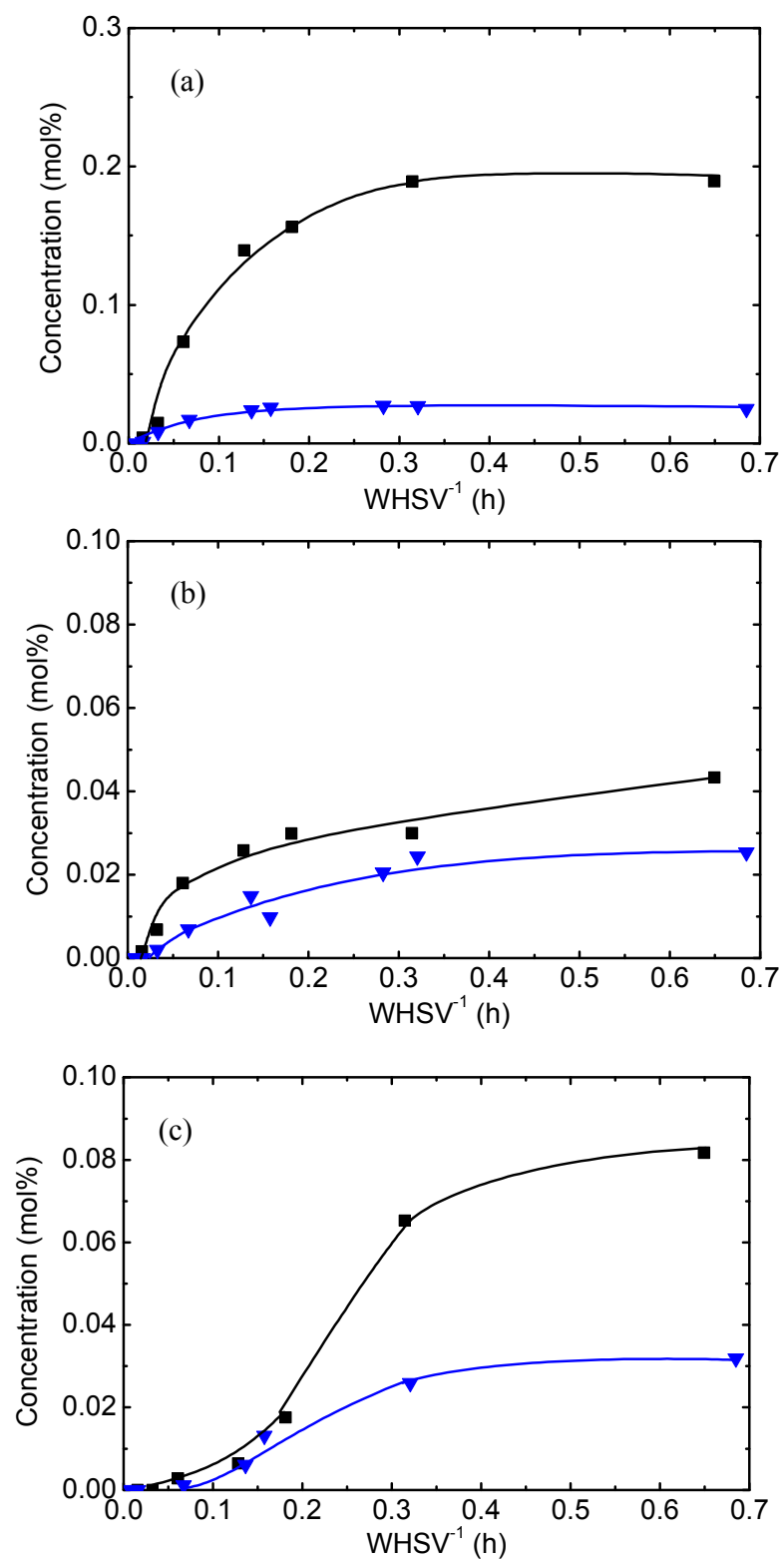

Figure 5.21. Effect of contact time on (a) PBs, (b) DEBs, and (c) TEBs concentrations at (■) 490 and (▼) 370°C.

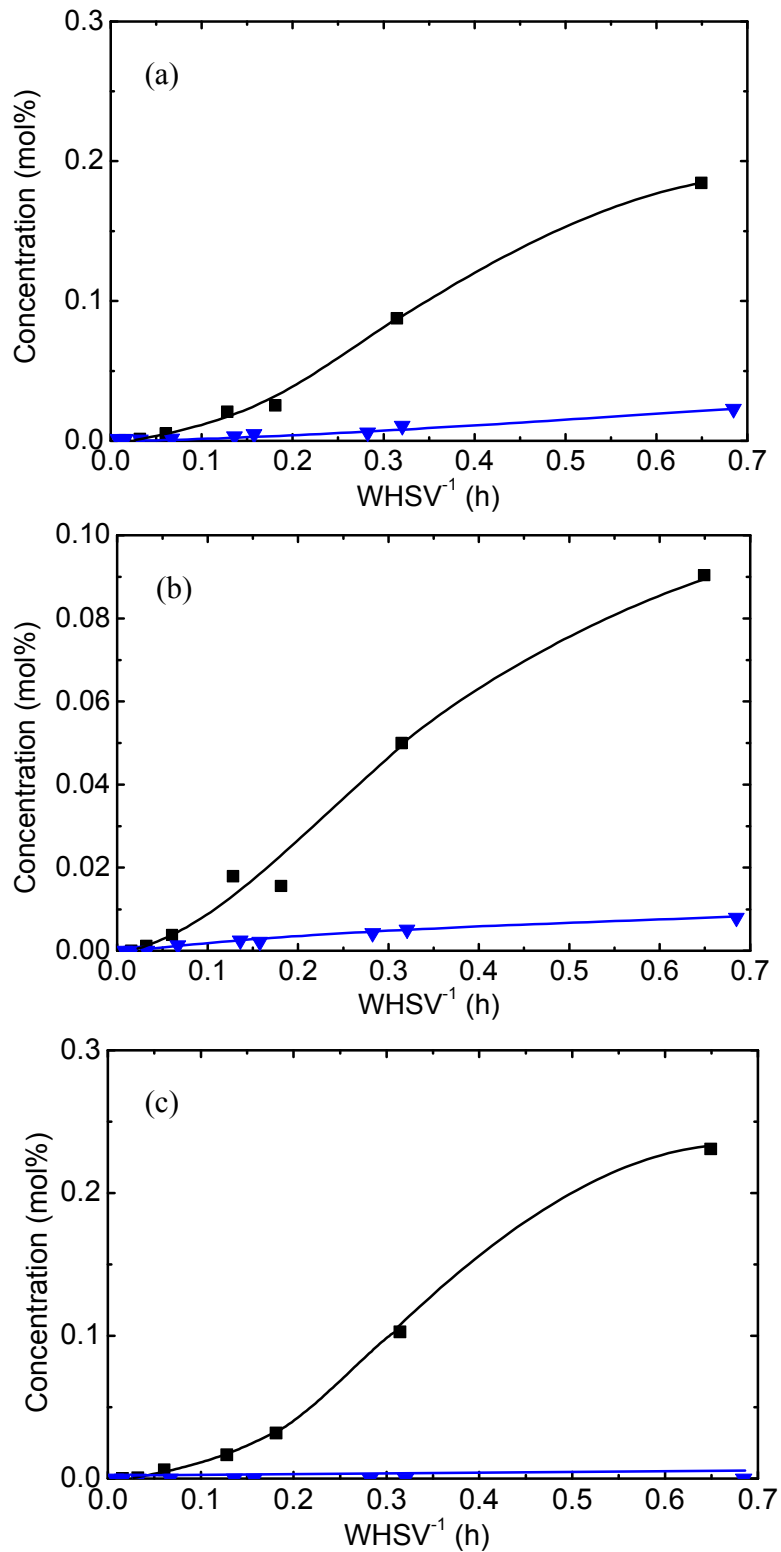

Figure 5.22. Effect of contact time on (a) toluene, (b) ethyl-toluene, and (c) other aromatics concentrations at (■) 490 and (▼) 370°C.

Figures 5.21 and 5.22 depict higher concentrations of by-products at 490°C and these products are formed from secondary reactions, such as polyalkylation of EB forming DEBs and TEBs, hydrogenolysis of EB forming toluene and methane, the transalkylation of EB and xylene forming ethyl-toluene and toluene or dimethylethylbenzene and benzene, and ethylation of toluene forming ethyl-toluene, etc.

Table 5.1 shows that at similar benzene conversion (11%), dramatic difference in ethene and EB selectivities in all carbon containing products was observed at 370 and 490°C, indicating that the reaction temperature affects the product distribution. At 370°C, ethene selectivity was relatively low (14.27 mol.%), while 75.33 mol.% of EB selectivity was yielded. On the other hand, quite low EB selectivity (~19 mol.%) and high ethene selectivity (~77 mol.%) at 490°C reveal that the

Table 5.1. Selectivities to all carbon containing products of benzene alkylation with ethane over PtH-ZSM-5 catalyst at 370 and 490 °C.

Reaction temperature	370 °C	490 °C
Ethane conversion (%)	1.57	5.25
Benzene conversion (%)	11.08	11.03
Selectivity (mol.%)		
Methane	0.39	0.39
Ethene	14.27	77.08
Propane	2.47	0.18
Propene	0.11	0.57
Butanes	0.18	0.07
Butenes	0	0.21
Toluene	0.82	0.12
Ethylbenzene	75.33	18.98
Xylenes	0.09	0.06
Propylbenzenes	2.05	1.61
Ethyltoluenes	0.39	0.08
Diethylbenzenes	1.86	0.40
Triethylbenzenes	1.97	0.06
Others	0.07	0.19

ethene formed at 490°C does not readily react with benzene into EB, but remains as ethene in the product mixture. This is due to the formation of EB is related to the thermodynamic equilibrium conversion of ethane dehydrogenation into ethene and hydrogen, benzene alkylation with ethane into EB and hydrogen and benzene alkylation with ethene into EB.

The results demonstrated very stable catalyst performance in benzene alkylation with ethane into EB over 1PtH-ZSM-5 catalyst at 290 and 370°C, while lower catalyst stability was observed at 490°C. Extremely low benzene and ethane conversions were observed at 290°C, indicating very low catalyst activity at this temperature. The catalyst

is expected to have even lower activity at lower temperature since ethane dehydrogenation and overall benzene alkylation with ethane into EB are endothermic reactions. On the other hand, the catalyst was active at 490°C but yielded large amount of side products, lowering EB selectivity. The equilibrium conversion of ethane dehydrogenation into ethene and hydrogen increases exponentially with increasing temperature (Fig. 4.1). As a result, larger amount of ethene could be formed at higher reaction temperature and could eventually lead to lower catalyst stability and EB selectivity. The results strongly suggest that EB formation proceeds *via* the same consecutive reaction steps at 370 and 490°C: (i) ethane dehydrogenation into ethene and hydrogen and (ii) benzene alkylation with ethene. The reaction temperature affects the rate of each reaction step, leading to different product distributions. The experimental results showed that the selected temperature range for the kinetic studies of benzene alkylation with ethane into EB was appropriate, and hence, further investigation, such as obtaining the optimum reaction temperature, could be carried out within 330-450°C range.

5.3. The optimum reaction temperature

Section 5.1 showed the preliminary investigation of benzene alkylation with ethane into EB over 1PtH-ZSM-5 catalyst at 370°C. The selection of the temperature range, based on the thermodynamic equilibrium conversions, was carried out to determine the reaction temperature of the catalytic studies. Section 5.2 demonstrated the effect of high (490°C) and low (290°C) temperatures on the catalyst performances and verified that the selected temperature range for further catalytic studies was appropriate. The results presented in section 5.2 showed low catalyst activity and stability at 290 and 490°C, respectively. Hence, the optimisation of the reaction temperature, for benzene alkylation with ethane into EB over 1PtH-ZSM-5 catalyst, will be carried out in the temperature range of 330-450°C, in which higher catalyst activity and stability could be achieved.

5.3.1. The effect of temperature on catalyst performance

Figure 5.23 shows that at low contact time, i.e. when the reactants are first in contact with the catalyst, the ethane conversion increases linearly with contact time in the temperature range between 330 and 450°C. This indicates that the initial rate of ethane conversion is dominated by the ethane dehydrogenation into ethene and hydrogen, i.e. the forward reaction. The ethane conversion reaches a plateau at high contact time showing that the rate of ethane conversion is affected by the reverse ethene hydrogenation reaction, which reproduces ethane.

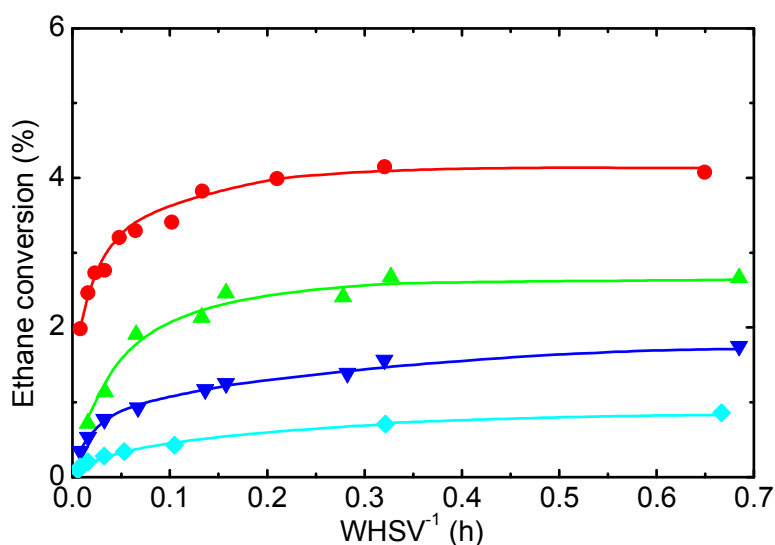

Figure 5.23. Effect of contact time on ethane conversion at (●) 450, (▲) 410, (▼) 370, and (◆) 330°C.

The transformation of ethane was 4% at 450°C while only about 2.5% of ethane was converted at 410°C ($\text{WHSV}^{-1} = 0.3 \text{ h}$). The higher rate of ethane transformation at 450°C could be due to the highly endothermic ethane dehydrogenation reaction, at which the equilibrium conversion increases exponentially with temperature (Fig. 4.1). As a result, more ethene could be produced at 450°C. Figure 5.24 shows that the benzene conversion increases from 15 to 17% when the temperature rises from 410 to 450°C. This indicates that the enhanced formation of ethene at high temperature does not encourage the transformation of benzene. The formation of EB is affected by the equilibrium conversion of benzene alkylation with ethane into EB and hydrogen which

increases linearly with temperature (Fig. 4.2), and benzene alkylation with ethene into EB which is an endothermic reaction. Hence, the benzene conversion increases slightly with increasing temperature even though more ethene is available for the transformation of benzene with ethene into EB at 450°C. The excess amount of ethene could either undergo oligomerisation and cracking reactions to produce other alkenes, or remains as ethene in the product mixture which consequently reduces the selectivity of EB in all products. Also, the catalyst stability could be affected as alkenes are known as important contributors to the coke formation over zeolite catalysts. This observation has proved further the suggestions discussed in Chapter 4. It was proposed that the benzene alkylation with ethane into EB over bifunctional catalyst should be carried out at low temperature. Lower ethane conversion would be obtained at low reaction temperature which could ensure the inherently low ethene concentration at any point in the reactor and enhancing the catalyst stability (Lukyanov and Vazhnova, 2008a).

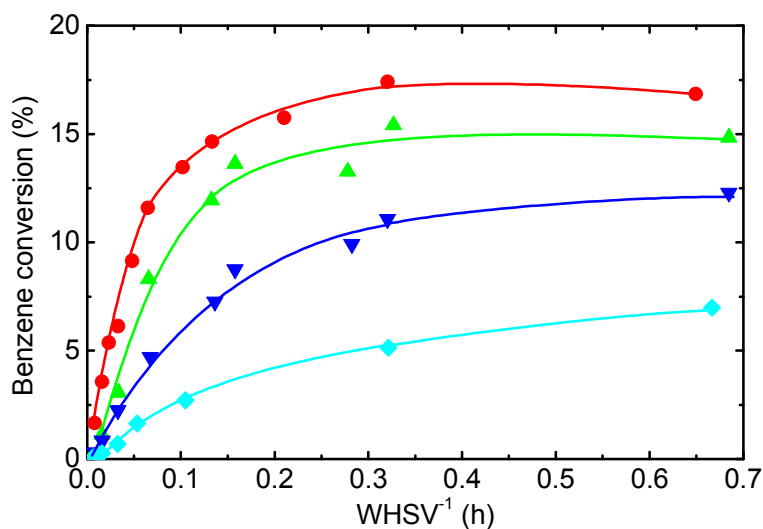

Figure 5.24. Effect of contact time on benzene conversion at (●) 450, (▲) 410, (▼) 370, and (◆) 330°C.

Figure 5.25 reveals very stable catalyst performance in benzene alkylation with ethane into EB at 330, 370 and 410°C. Indeed, no changes were observed at these temperatures in benzene conversion during nearly 50 h on stream. Slightly lower catalyst stability was observed at 450°C, where benzene conversion decreased about 1%, from 11.7% to 10.7%, over 48 h on stream. The catalyst deactivation at higher

temperature could be due to the higher rate of coke formation at high temperature compared to lower temperature. This is evidenced further when comparing the catalyst performance at 450 and 490°C at the same contact time ($WHSV^{-1} = 0.13 \text{ h}$) (Figs. 5.10 and 5.25).

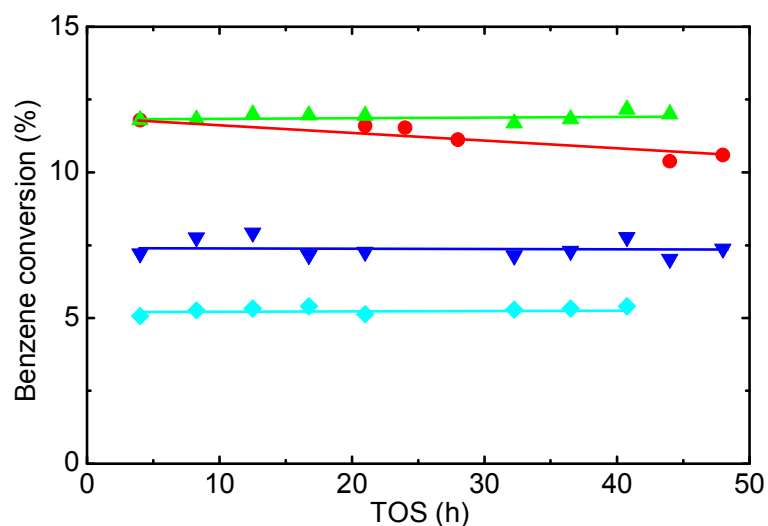

Figure 5.25. Effect of time on stream on benzene conversion at (●) 450°C, $WHSV = 15.5 \text{ h}^{-1}$, (▲) 410°C, $WHSV = 7.5 \text{ h}^{-1}$, (▼) 370°C, $WHSV = 7.2 \text{ h}^{-1}$, and (◆) 330°C, $WHSV = 3.1 \text{ h}^{-1}$.

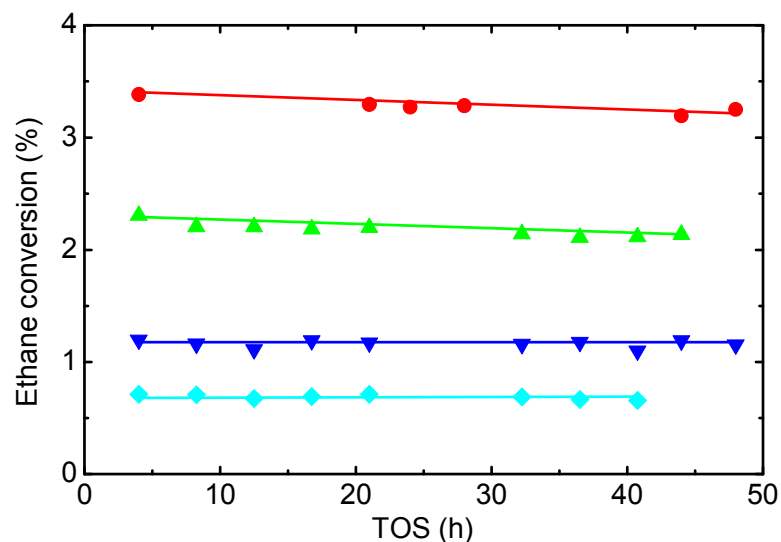

Figure 5.26. Effect of time on stream on ethane conversion at (●) 450°C, $WHSV = 15.5 \text{ h}^{-1}$, (▲) 410°C, $WHSV = 7.5 \text{ h}^{-1}$, (▼) 370°C, $WHSV = 7.2 \text{ h}^{-1}$, and (◆) 330°C, $WHSV = 3.1 \text{ h}^{-1}$.

At 450°C, the benzene conversion dropped from 15.2 to 14.5% over 48 h on stream (Fig. 5.27), while the benzene conversion decreased nearly 3% from 15.7% over 44 h on stream at 490°C (Fig. 5.10). Additionally, at the same contact time (WHSV⁻¹ = 0.13 h), the

Table 5.2. Selectivities to all aromatic products of benzene alkylation with ethane over PtH-ZSM-5 catalyst at different reaction temperatures, $\tau = 0.13$ h, TOS = 20 h.

Temperature (°C)	490	450	410	370
Ethane conversion (%)	5.81	3.82	2.13	1.14
Benzene conversion (%)	14.18	14.65	11.95	7.31
Selectivity (mol.%)				
Toluene	1.63	1.19	0.58	0.47
Ethylbenzene	81.47	80.69	88.28	92.42
Xylenes	0.65	0.32	0.11	0
Propylbenzenes	10.98	11.37	6.76	3.51
Ethyltoluene	1.41	1.31	0.63	0.37
Diethylbenzenes	2.04	2.28	2.53	2.19
Triethylbenzenes	0.50	0.89	0.68	0.90
Other aromatics	1.32	1.95	0.43	0.14
Total	100	100	100	100

ethane conversion declined nearly 1% from 6.2 to 5.3% at 490°C (Fig. 5.11), while the drop in ethane conversion is less than 0.2% (Fig. 5.27) over nearly 48 h on stream at 450°C. The level of the catalyst deactivation is very low at low temperature, as it follows from the fact that no noticeable changes have been observed in benzene and ethane conversions during nearly 48 h of the reaction (Figs. 5.25 and 5.26). These observations suggest that higher catalyst stability was observed at low reaction temperature which could be due to slower coke formation at lower temperature.

The decrease of catalyst stability at higher reaction temperature is associated possibly with higher coking rate which can be related to the enhanced formation of C₁₀-C₁₂ alkylbenzenes and naphthalenic compounds as these compounds are usually considered as coke precursors in reactions over zeolite catalysts (Lukyanov and Vazhnova 2008b). Table 5.2 illustrates the effect of reaction temperature on product distribution of benzene alkylation with ethane into EB over 1PtH-ZSM-5 bifunctional catalyst at the same contact time (WHSV⁻¹ = 0.13 h). It is essential to carry out the analysis at same contact time during steady operation (TOS = 20 h) to ensure the formation of products are solely affected by temperature, since it was suggested by Lukyanov and Vazhnova (2008b) that the formation of heavy aromatics could be more favourable at high contact time and the catalyst deactivation could be more severe at

longer time on stream. The selectivities of side aromatic products are relatively high at 450 and 490°C (Table 5.2), at which drops in benzene (Figs. 5.10 and 5.27) and ethane (Figs. 5.11 and 5.27) conversions with time on stream were observed at both temperatures. On the other hand, relatively low amount of heavy aromatics were yielded at 410 and 370°C and very stable operation of PtH-ZSM-5 was obtained at these temperatures (Figs. 5.25 and 5.26). This observation supports further that the rates of formation of heavy aromatics could be enhanced at high temperature which could lead to catalyst deactivation. Similar benzene conversions and selectivities to all aromatic products but different ethane conversions were observed at 450 and 490°C, at 0.13 h of contact time (Table 5.2). This suggests that the rise in reaction temperature from 450 to 490°C, at 0.13 h of contact time, has improved the ethane conversion but has no effect on the benzene conversion and aromatic product distribution.

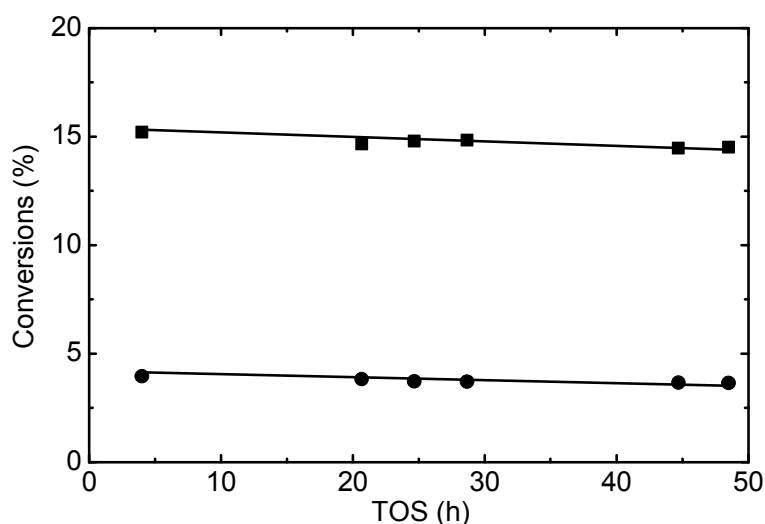

Figure 5.27. Effect of time on stream on (■) benzene and (●) ethane conversions at 450°C, WHSV = 7.5 h⁻¹.

The previous section showed that the temperature would affect the catalyst activity and stability as well as the product distribution. Relatively high catalyst activity was observed at high temperature but this has led to the drop of catalyst stability which could be due to the enhanced rate of coke formation at high temperature. The following section will discuss in detail the effect of temperature on the product selectivities which would directly illustrate the efficiency of the catalyst. At 450°C, the selectivity of

hydrogen was around 50 mol.% at low ethane conversion, then it rose slightly to 53 mol.% at higher ethane conversion. Similar performance was observed in the temperature range between 330 and 450°C (Fig. 5.28a). At 330°C, the selectivity of ethene and EB achieved 47.5 and 2.5 mol.% respectively, when 0.1% of ethane was transformed. This indicates that hydrogen, ethene and EB are the products formed at low contact time as the total selectivity of these three products is 100 mol.%. The ethene selectivity dropped dramatically to 2 mol.% while the EB selectivity rose to nearly 40 mol.% when the ethane conversion increased from 0.1 to 1% at 330°C. Similar effect of ethane conversion on ethene and EB selectivities was observed at 370°C.

This observation suggests that the ethane feed would convert firstly into ethene and hydrogen *via* dehydrogenation of ethane, and then the produced ethane could be alkylated by benzene forming EB. The ethane conversion exhibited slightly different effect on the ethene and EB selectivities at 410 and 450°C (Figs. 5.28b and 5.28c). High ethene concentrations were observed at 410 and 450°C, i.e. the exponential rise in equilibrium conversion of ethane dehydrogenation at high temperature. Hence, the ethene concentration remains relatively high in the product mixture at 410 and 450°C even after being partly consumed in benzene alkylation with ethene into EB and consecutive reactions such as oligomerisation, cracking, etc. Different product distributions were observed, at 2% of ethane conversion, at 370, 410 and 450°C. At 370°C, 5 and 36 mol.% of ethene and EB selectivities, respectively, were obtained, while the catalyst yielded 46 mol.% of ethene selectivity and 4 mol.% of EB selectivity at 450°C. At 450°C, the conversion of ethane achieved 2% at 0.006 h of contact time (Fig. 5.23) with 1.6% of benzene conversion (Fig. 5.24). This indicates that the primary reaction, ethane dehydrogenation, is dominating, and hence the relatively high ethene selectivity was observed. On the other hand, at 370°C, 2% of ethane was converted at 0.69 h of contact time with nearly 17% of benzene conversion. This suggests that the transformation of ethane is relatively low at low temperature and requires more catalyst to achieve higher ethane conversion which would enhanced the conversions of secondary and tertiary reactions, leading to relatively low ethene selectivity.

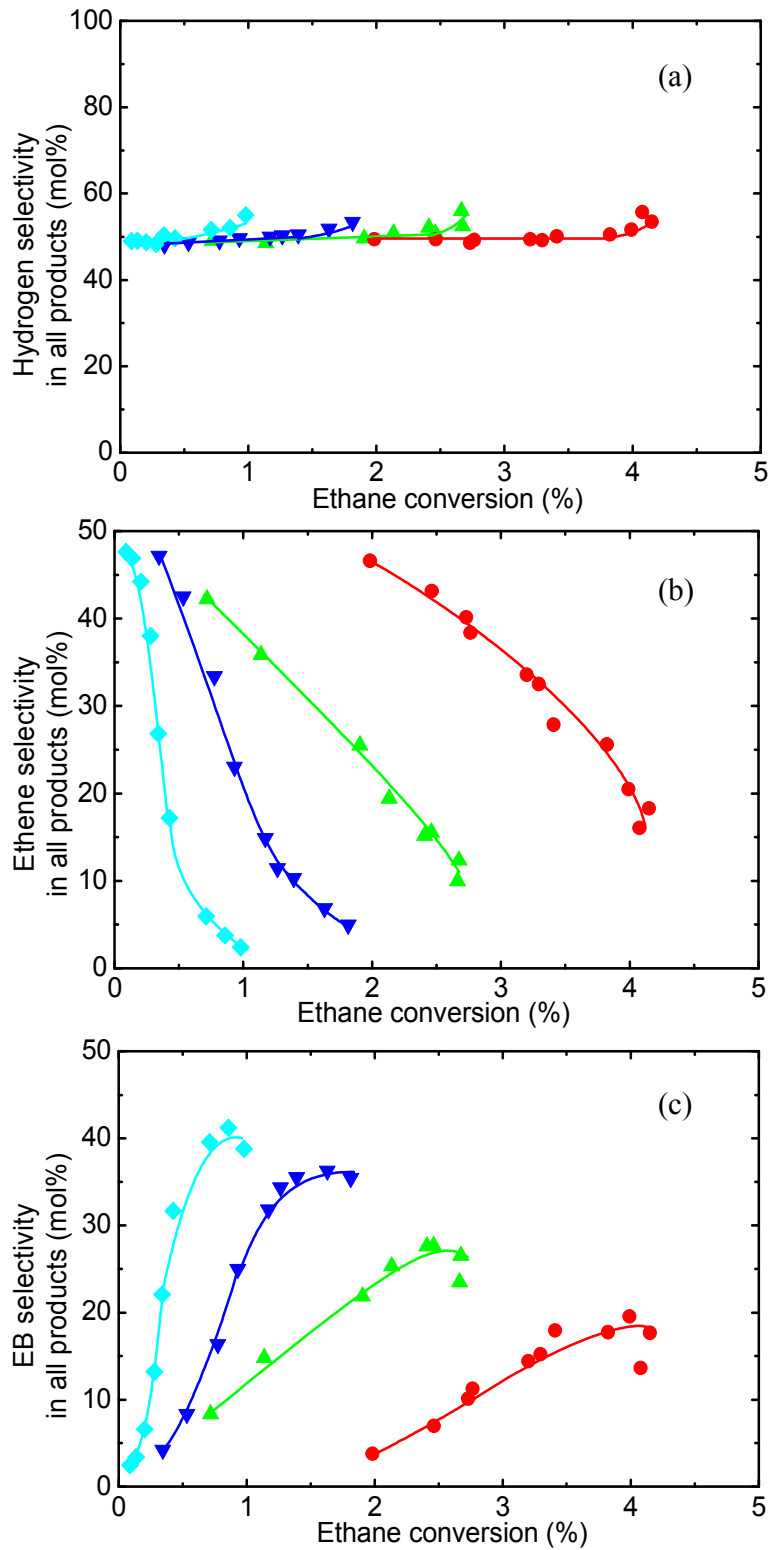

Figure 5.28. Effect of ethane conversion on (a) hydrogen, (b) ethene, and (c) EB selectivities in all products at (●) 450, (▲) 410, (▼) 370, and (◆) 330°C.

At 330°C, hydrogen, ethene and EB were the products observed at 0.8% of ethane conversion and the total selectivity of these products was 100 mol.%. However, the summation of the selectivities of hydrogen, ethene and EB was only 92 mol.% when 1% of ethane was converted, which indicates that the formation of other products such as iPB, DEBs becomes noticeable at high contact time.

The formation of aromatic products, such as EB, DEBs and TEBs etc., is formed from reacting benzene with alkenes or alkylbenzenes because longer reaction pathways are required for the aromatisation of ethane into these aromatics. As a result, it would be more appropriate to carry out analyses on the effect of temperature on aromatic product selectivities by plotting the aromatic product selectivities against benzene conversion (Figs. 5.29 and 5.30).

The benzene alkylation with ethane into EB over 1PtH-ZSM-5 catalyst at 330°C yielded 95 mol.% of EB selectivity in aromatic products at 8% of benzene conversion. At 410°C, more than 80 mol.% of EB selectivity was attained when 15% of benzene was converted and the EB selectivity was slightly higher than 70 mol.% at 17% of benzene conversion at 450°C (Fig. 5.29a). It was discussed in the previous section that the drop of EB selectivity with increasing benzene conversion was due to the formation of secondary and tertiary products. For example, at 450°C, the EB selectivity experienced a slight drop at around 2% of benzene conversion due to the formation of secondary products. Then the dramatic drop of EB selectivity at around 12% of benzene conversion was observed when the formations of tertiary products become favourable.

Figure 5.29a shows very clearly that the drop of EB selectivity is also affected by reaction temperature and more dramatic decline was observed at higher temperature. The significant drop of EB selectivity after 12% of benzene conversion at 450°C could be mainly due to the formation of TEBs, toluene and other aromatics which dramatic rise in selectivities was observed (Figs. 5.29 and 5.30).

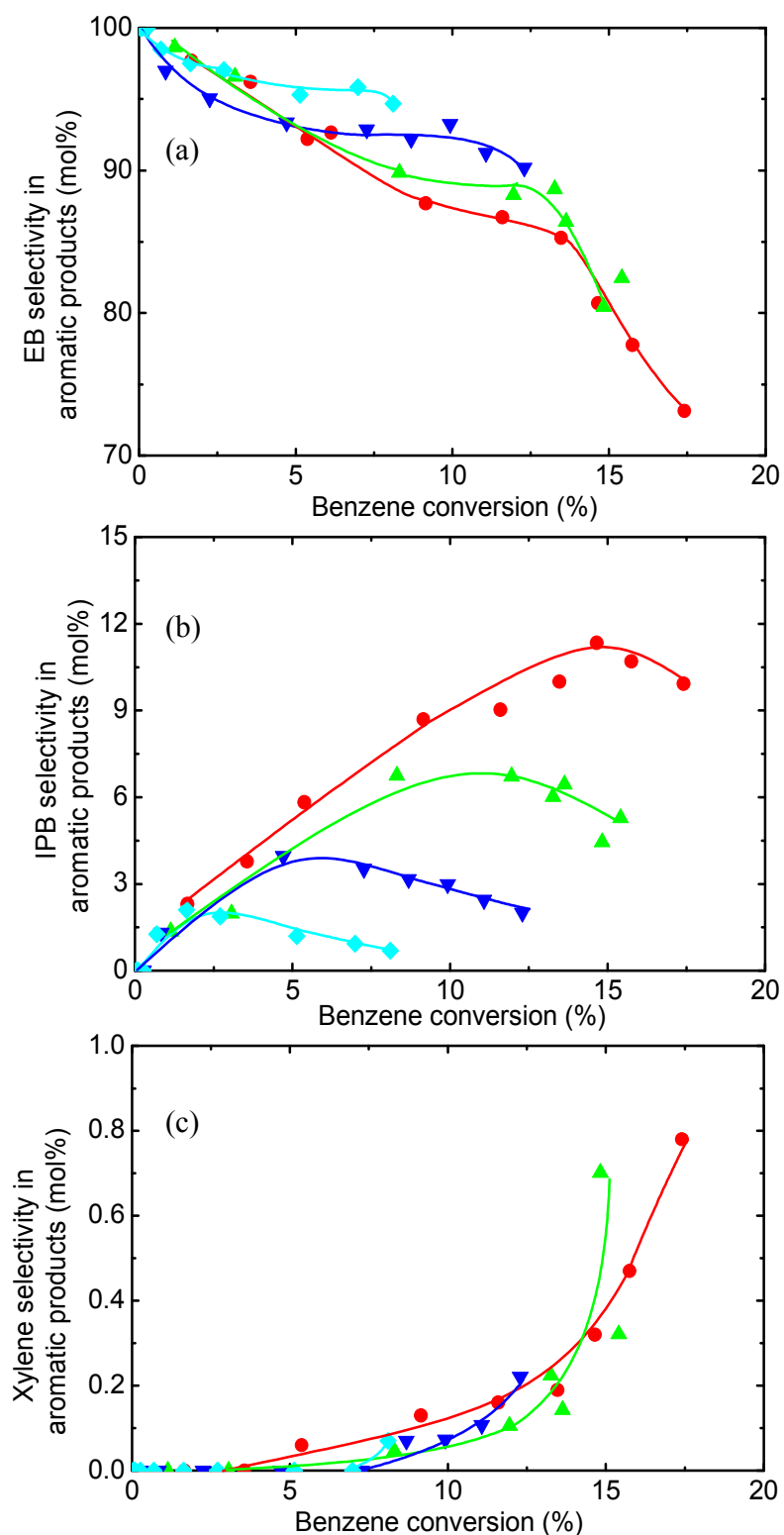

Figure 5.29. Effect of benzene conversion on (a) EB, (b) iPB, and (c) xylene selectivities in all aromatic products at (●) 450, (▲) 410, (▼) 370, and (◆) 330°C.

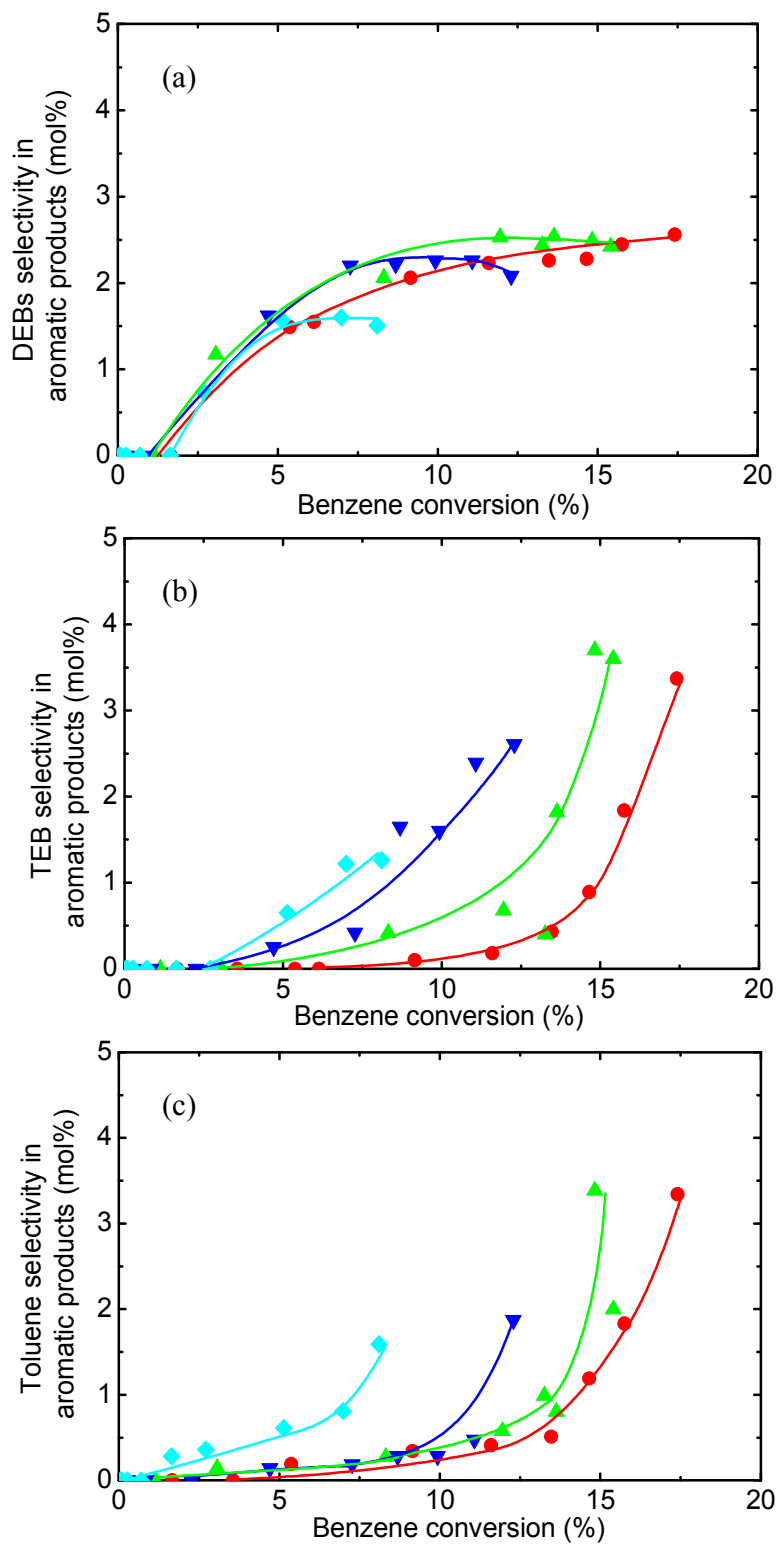
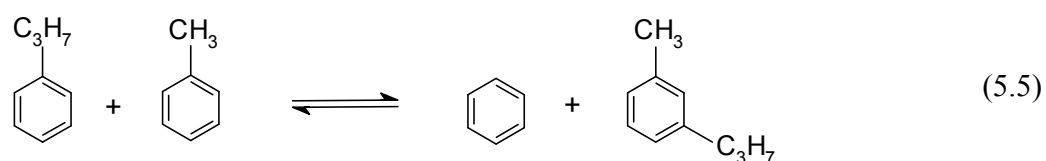
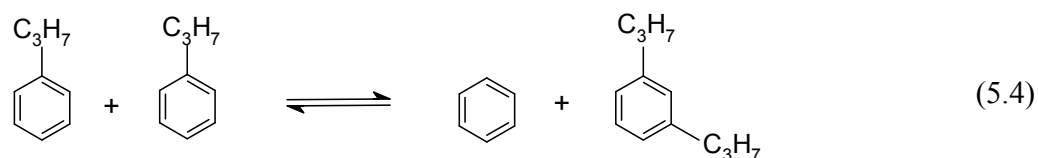

Figure 5.30. Effect of benzene conversion on (a) DEBs, (b) TEBs, and (c) toluene selectivities in all aromatic products at (●) 450, (▲) 410, (▼) 370, and (◆) 330°C.

The selectivity of iPB increased gradually with increasing benzene conversion, and then started to decline at 15% of benzene conversion. The drop of iPB selectivity in aromatic products could be either due to the decrease of iPB concentration in the product mixture, resulting from the consumption of iPB in consecutive reactions, or the rise of tertiary product concentrations leading to relatively low proportion of iPB concentration in the product mixture. IPB could be converted further *via* disproportionation of two iPB to benzene and diisopropyl benzenes (DiPBs) (Eq. 5.4). Another possible reaction is the transalkylation of iPB where iPB reacts with toluene to yield equimolar quantities of isopropyl toluene and benzene (Eq. 5.5) (Bandyopadhyay, *et al.* 1996).



IPB and DEBs selectivities are observed at very low benzene conversion suggesting that both are the secondary products which form at low contact time. The selectivity of DEBs in aromatic products reaches plateau at high benzene conversion suggesting that the formation of DEBs is limited by reverse and consecutive reactions. Xylene, TEBs, other aromatics and toluene start to be noticeable after specific amount of benzene have been transformed and the selectivities of these products reveal no indication of decrease. This observation suggests that these are the tertiary products and are not being consumed further by consecutive reactions. Figures 5.30b and 5.30c illustrate that relatively high TEBs and toluene selectivities in aromatic products were observed at 410 and 450°C. Additionally, the selectivities of C₁₀-C₁₂ alkylbenzenes and naphthalenic compounds, which were observed in traces at 370°C, were relatively high

at 410 and 450°C. This observation evidenced further that the rates of formation of heavy aromatic products are enhanced at high temperature.

In summary, the experiment data shows that the selectivity of EB, which directly reflects the efficiency of the catalyst, dropped dramatically at 410 and 450°C. It is suggested that the drop of EB selectivity at both temperatures could be due to the conversion of EB, by consecutive reactions, which would lead to lower EB concentration in the reaction mixture. Additionally, the enhanced formation of heavy aromatics at 410 and 450°C contributes further to the drop of EB selectivity. On the other hand, high EB selectivity (≥ 95 mol.%) with traces of heavy aromatics was observed at 330°C. However, only 8% of benzene was converted even though double amount of catalyst was loaded. At 370°C, more than 90 mol.% of EB selectivity was achieved at 12.5% of benzene conversion and the catalyst operated with high stability for up to nearly 50 h on stream.

5.3.2. The effect of temperature on product distribution

Previous section showed the effect of temperature on catalyst performance in terms of activity, selectivity and stability. The catalyst yielded relatively high activity at high temperature. At the same time, the high temperature enhanced the formation of coke, leading to relatively decreased stability. Additionally, relatively low EB selectivity was observed at high reaction temperature due to the enhanced formation of tertiary products. This section concentrates on the effect of temperature on the product distribution.

At 450°C, ethene concentration rose to 1.9 mol.% at 0.02 h of contact time and started to decrease with increasing contact time (Fig. 5.31b). The rise of ethene concentration with increasing contact time (at low contact time) suggests that the primary reaction step, i.e. ethane dehydrogenation into ethene and hydrogen, is taking place. Then, ethene concentration started to drop indicating that ethene was consumed by consecutive reactions such as benzene alkylation with ethene, which is favourable at higher contact time.

At 0.065 h of contact time, 1.8 mol.% of ethene concentration was observed at 450°C; while at 410°C, the catalyst yielded 0.8 mol.% of ethene concentration at the same contact time. Relatively low ethene concentrations were obtained, at the same contact time, at 370°C and 330°C, i.e. 0.4 and 0.15 mol.%, respectively (Fig. 5.31b). The dramatic rise of ethene concentration from 410 to 450°C could be due to the exponential increase of equilibrium conversion of ethane dehydrogenation into ethene and hydrogen at high reaction temperature. The change of hydrogen concentration with reaction temperature supports further this proposal as ethane dehydrogenation would produce equimolar amounts of ethene and hydrogen (Fig. 5.31a). The hydrogen concentration was 2.8 mol.% at 450°C, which is about 1.2 mol.% higher than at 410°C. The hydrogen concentration dropped half to 0.8 mol.% at 370°C, which is only 0.45 mol.% higher than at 330°C.

Figure 5.31c depicts that in the temperature range between 330 and 450°C, the EB concentration increased significantly with increasing contact time during the first 0.3 h of contact time. At 330 and 370°C, the EB concentration rose slightly with further increase in contact time. On the other hand, EB concentration remained constant at 410°C and decreased slightly at 450°C when the contact time increased from 0.3 to 0.6 h. The drop of EB concentration at high contact time, at 450°C, proposes that EB is being consumed by consecutive reactions which are favourable at high contact time.

The EB concentration reaches plateau at 410°C suggesting that dealkylation of EB into benzene and ethene takes place and limits EB concentration. Obviously, this reverse reaction, EB dealkylation into benzene and ethene, takes place at all temperature. However, the change of EB concentration at high contact time suggests that the dominating reactions are affected by temperature. At 450°C side reactions such as hydrogenolysis of EB, could be dominating, leading to the drop in EB concentration at high contact time. On the other hand, at 410°C, the reverse dealkylation of EB could be dominating, and hence, a plateau was observed at high contact time. At 370 and 330°C, benzene alkylation with ethene into EB could be dominating, leading to the slight increase in EB concentration at high contact time (see Fig. 5.31c).

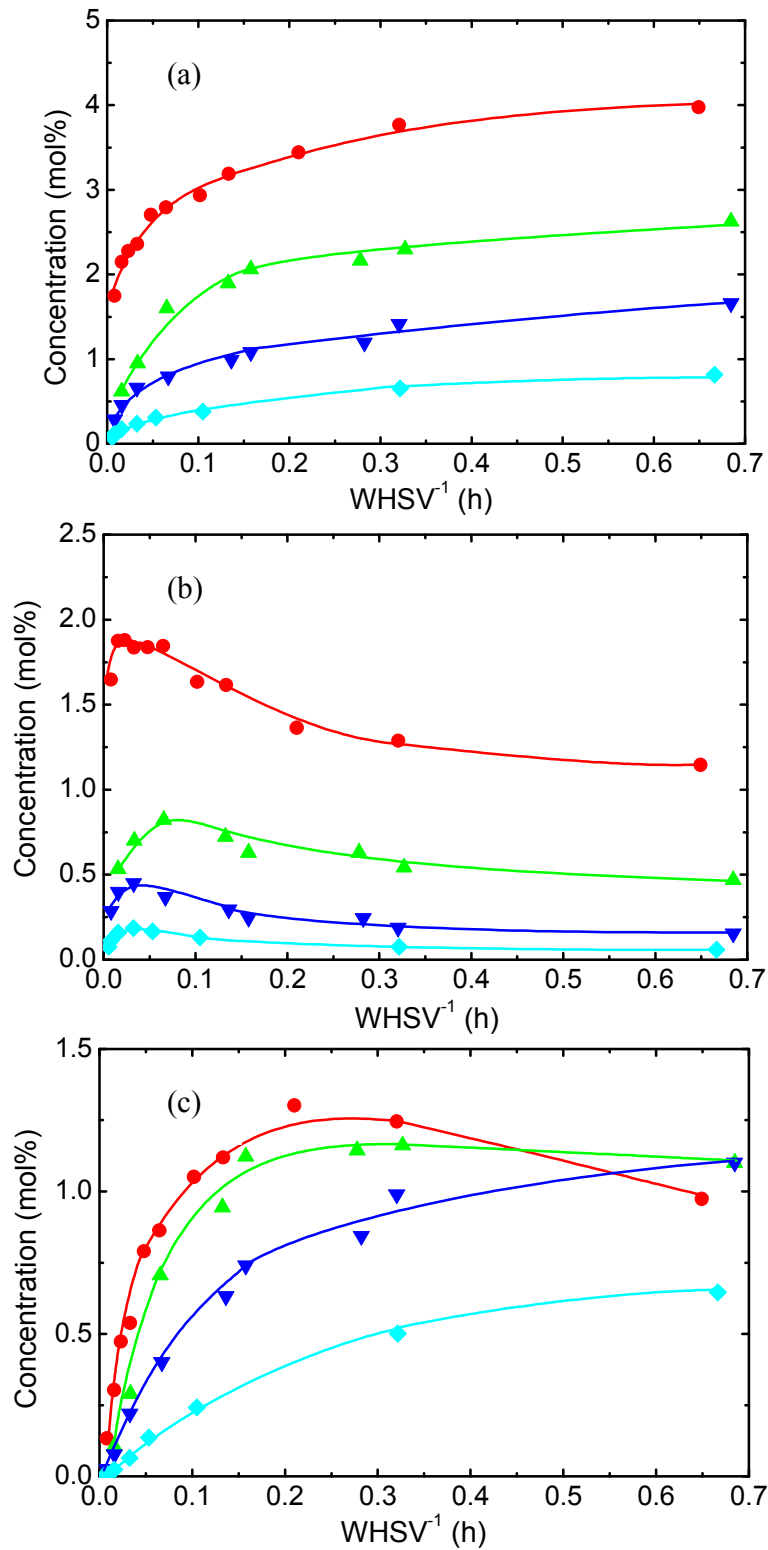

Figure 5.31. Effect of benzene conversion on (a) hydrogen, (b) ethene, and (c) EB concentrations at (●) 450, (▲) 410, (▼) 370, and (◆) 330°C.

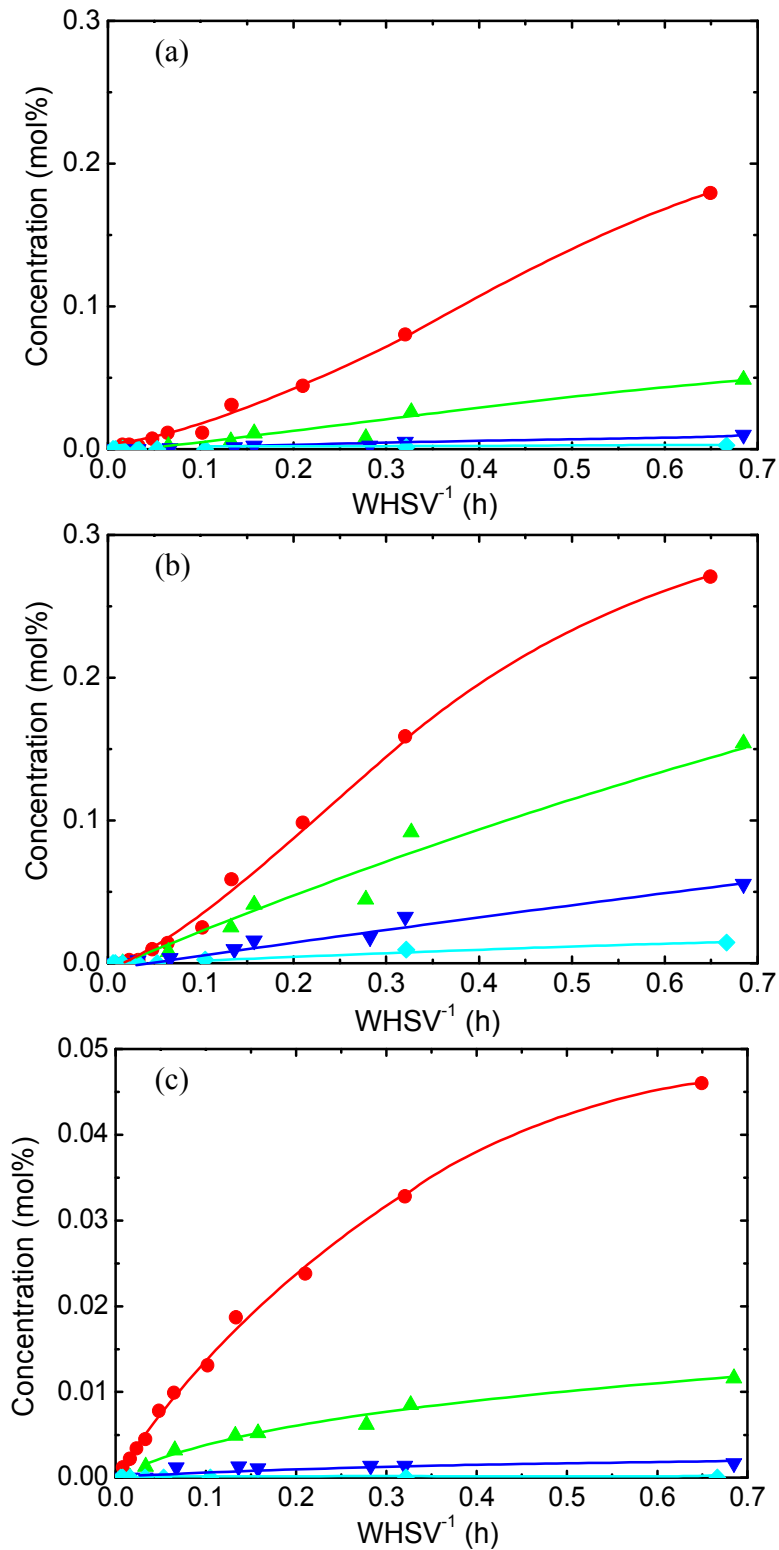

Figure 5.32. Effect of benzene conversion on (a) methane, (b) propane, and (c) propene concentrations at (●) 450, (▲) 410, (▼) 370, and (◆) 330°C.

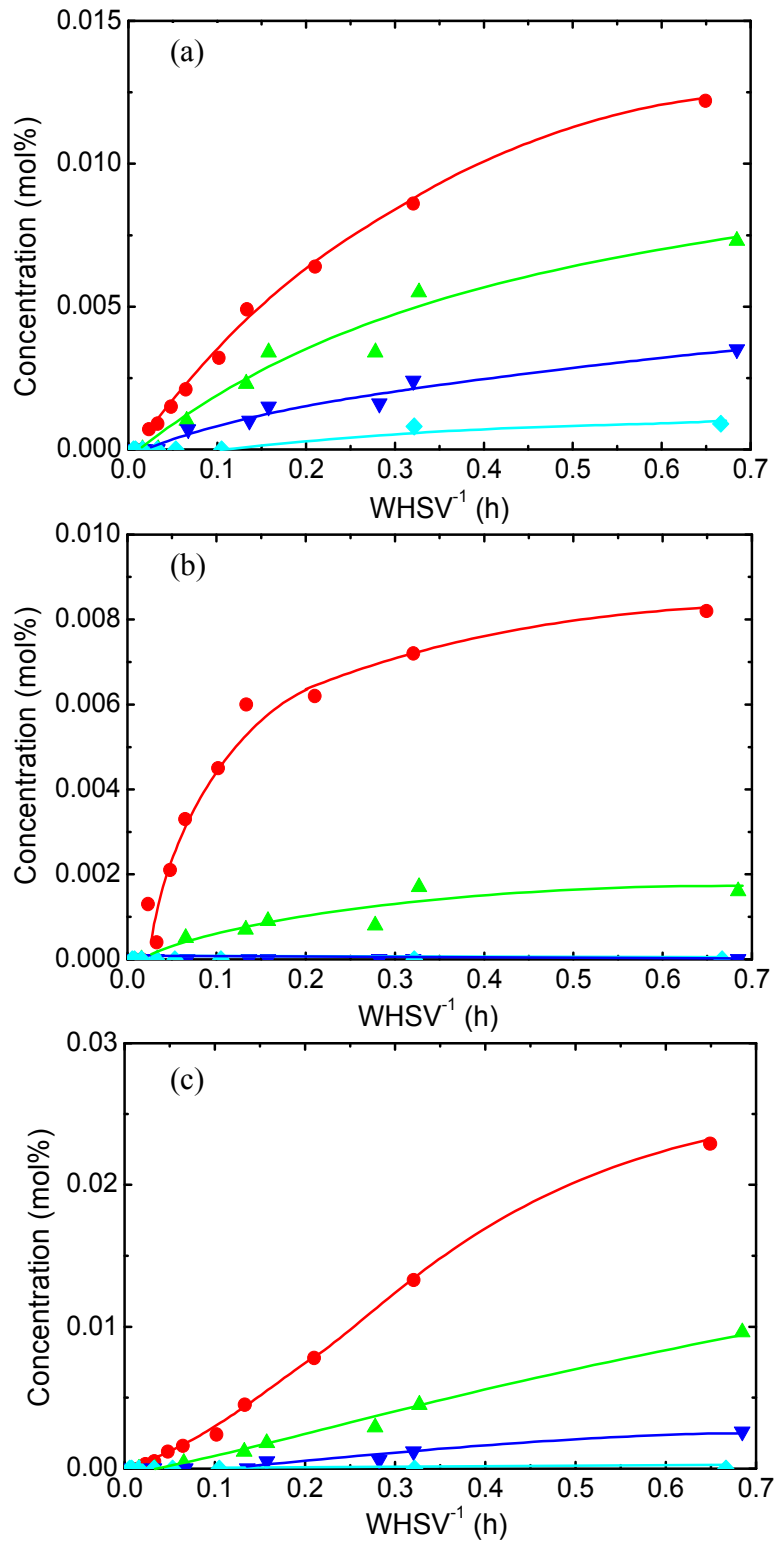

Figure 5.33. Effect of benzene conversion on (a) butanes, (b) butenes, and (c) xylenes concentrations at (●) 450, (▲) 410, (▼) 370, and (◆) 330°C.

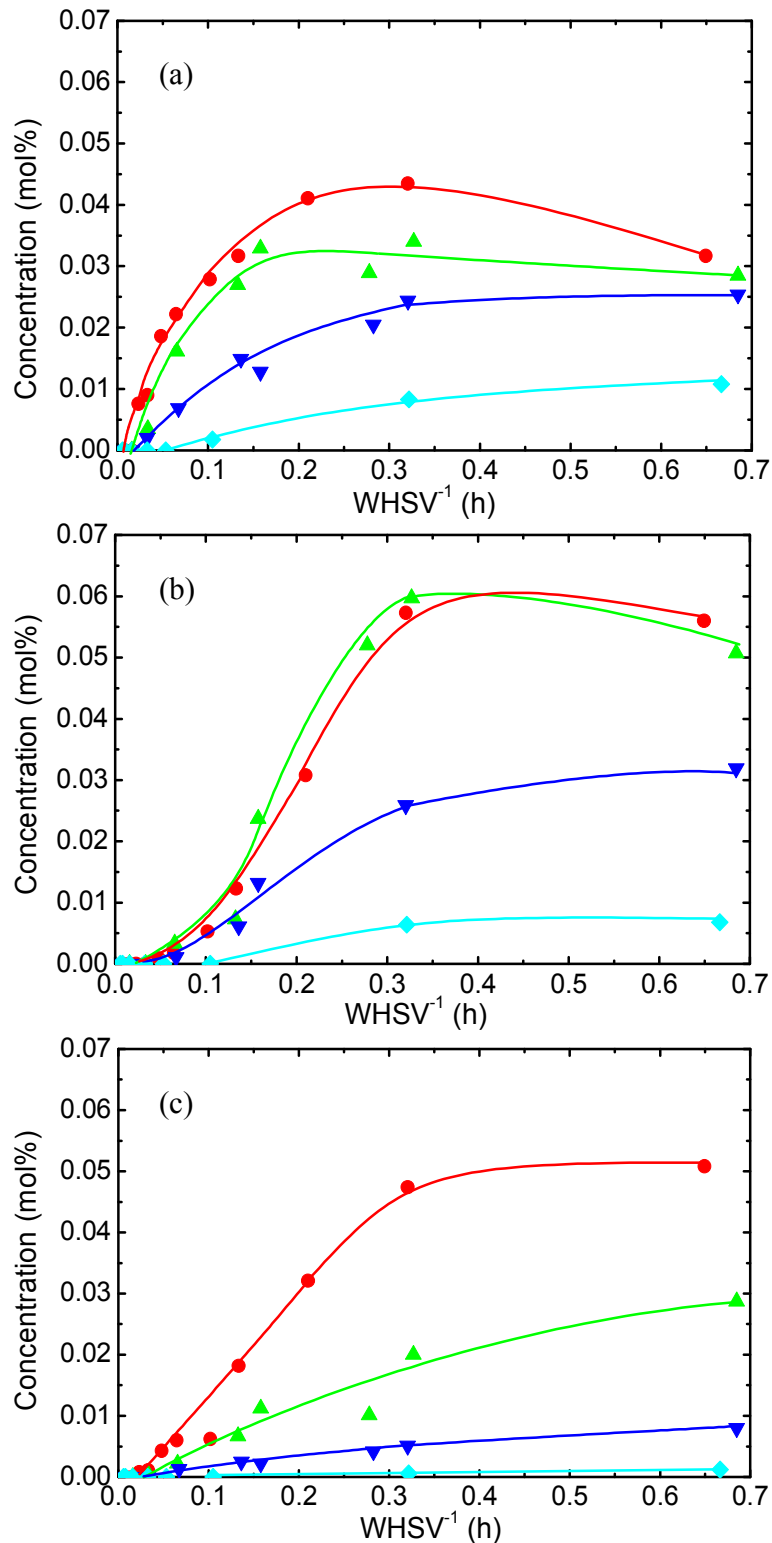

Figure 5.34. Effect of benzene conversion on (a) DEBs, (b) TEBs, and (c) ethyltoluene concentrations at (●) 450, (▲) 410, (▼) 370, and (◆) 330°C.

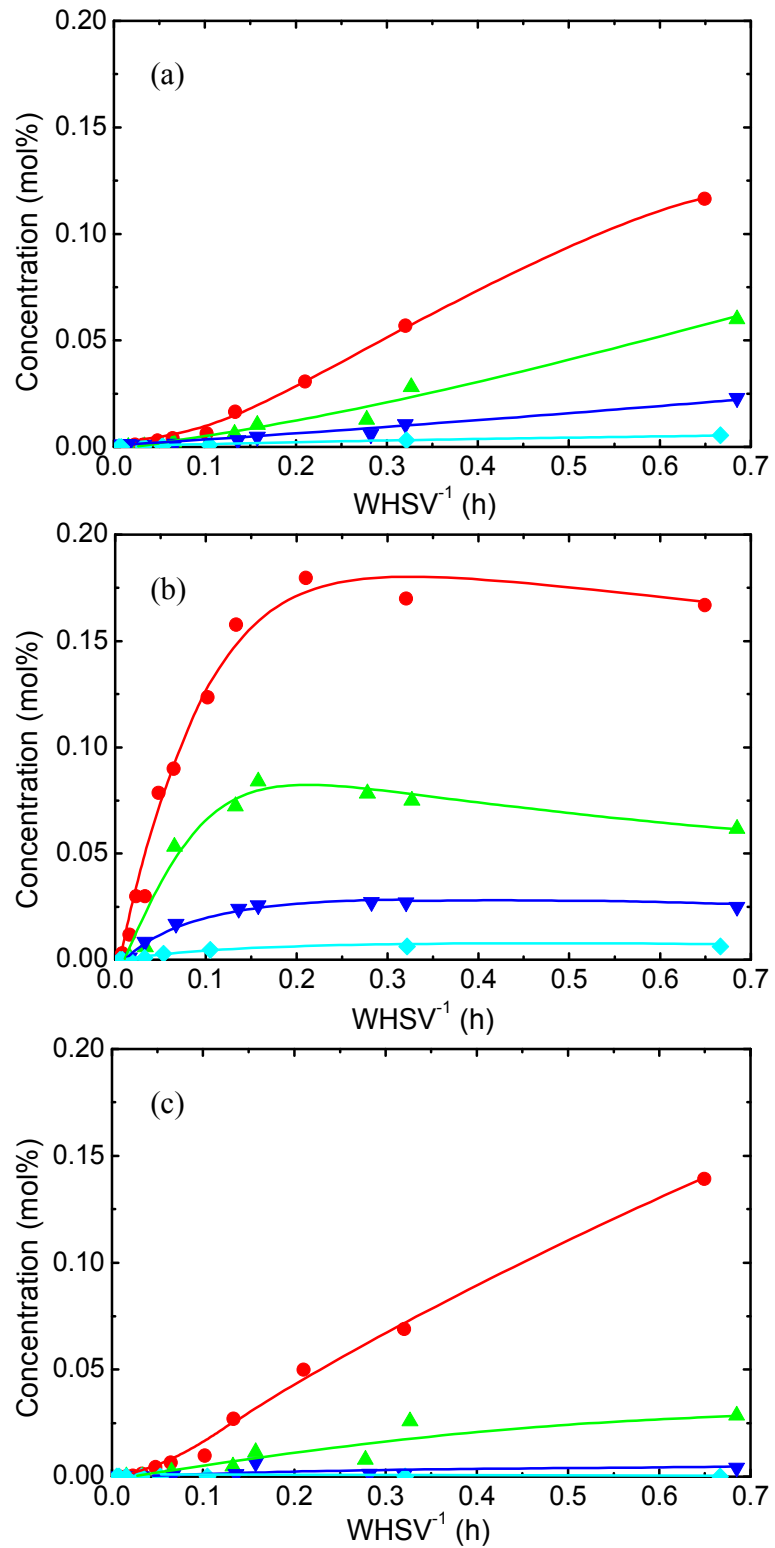

Figure 5.35. Effect of benzene conversion on (a) toluene, (b) PBs, and (c) other aromatics concentrations at (●) 450, (▲) 410, (▼) 370, and (◆) 330°C.

Figures 5.32 and 33 show higher methane, propane, propene, butanes and butenes concentrations at 450°C. Propane, propene, butanes and butenes could be the products of oligomerisation and cracking reactions and the initial reaction steps of the sequence of alkene oligomerisation and cracking reactions are the bimolecular ethene dimerisation steps (Lukyanov and Vazhnova, 2008a). As a result, the relatively high concentration of the light alkanes and alkenes (Figs. 5.32 and 5.33) at 450°C could be related to the relatively high concentration of ethene at this temperature (Fig. 5.31b). The ethane dehydrogenation into ethene and hydrogen is enhanced at 450°C due to the exponential rise of equilibrium conversion at high temperature and this leads to relatively high ethene concentration at 450°C. This high concentration of ethene would be converted further into EB *via* benzene alkylation and into light alkanes and alkenes *via* oligomerisation and cracking reactions. The high concentration of ethene favours the oligomerisation and cracking reactions, leading to high concentration of side products which would decrease the selectivity of EB in all products (Fig. 5.28c).

On the other hand, relatively low concentrations of light alkanes and alkenes were observed at 410°C (Figs. 5.32 and 5.33) but the EB concentration was comparable to 450°C (Fig. 5.31c). It is suggested that the ethene formed at 410°C could be converted mainly into EB and hindered the formations of side products which involved the transformation of ethene. Additionally, Figures 5.32 and 5.33 demonstrate clearly that the formations of light alkanes and alkenes are not favourable at 330 and 370°C which is likely to be due to the relatively low ethene concentration at these temperatures.

At 0.1 h of contact time, similar DEBs concentrations were observed at 410 and 450°C, i.e. 0.025 and 0.028 mol.%, respectively, while at 370°C, the catalyst yielded 0.01 mol.% of DEBs at the same contact time. At high contact time ($\text{WHSV}^{-1} = 0.65 \text{ h}$), the difference in DEBs concentration, due to reaction temperature, becomes less significant (Fig. 5.34a). Figure 5.34b shows that large amount of TEBs was observed at 410 and 450°C at high contact time. This observation suggests that the formation of TEBs, *via* DEBs alkylation with ethene, is favourable at high contact time and temperature. Hence, at high temperature and contact time, DEBs could be consumed at

higher rate by alkylation with ethene to form TEBs, and hence similar DEBs concentrations were obtained at 370, 410 and 450°C (WHSV⁻¹ = 0.65 h). This suggestion agrees well with the observed effect of contact time and temperature on DEBs concentration (Fig. 5.34a).

Significant amounts of side products, such as toluene, xylenes, ethyltoluene, and other aromatics, were yielded at 450°C at high contact time (Figs. 5.33-5.35). These products are mainly formed from consecutive reactions which involve the transformation of EB. Figure 5.31c shows that the drop of EB concentration at 450°C, at high contact time, could be due to the enhanced formation aromatic side products. The high concentration of aromatic side products at 450°C could lead to low EB selectivity in aromatic products and contributes to the coke formation, decreasing the catalyst stability.

In summary, the investigation of the effect of temperature on benzene alkylation with ethane into EB over PtH-ZSM-5 bifunctional catalyst started with the preliminary analysis of the feasibility of the reaction. Transient period was observed during the preliminary investigation. Consideration of this result has led to the conclusion that the nature of transient period is a complex interplay of a great variety of factors. Hence, further research was carried out under steady state reaction conditions. The preliminary investigation was performed at 370°C and has shown impressive catalyst performance in terms of activity, stability and selectivity. Then, the selection of the temperature range for further investigation was carried out based on the thermodynamic equilibrium of ethane dehydrogenation into ethene and hydrogen (Eq. 5.1) and the overall benzene alkylation with ethane into EB and hydrogen (Eq. 5.3). The temperature range of 290-490°C was selected, as the equilibrium ethane dehydrogenation conversions into ethene are relatively low and should ensure low ethene concentration at any point in the reactor, and eventually contribute to the catalyst stability and effectiveness. The experimental results showed extremely low catalyst activity at 290°C. On the other hand, large amounts of side products were observed at high temperatures, which could eventually lower the catalyst stability and EB selectivity. The catalyst demonstrates very stable

performance up to nearly 48 h on stream at 370°C and more than 90 mol.% of EB selectivity in aromatic products at 12.5% of benzene conversion. This suggests that 370°C is the optimum reaction temperature. The results demonstrate that EB formation proceeds at all temperatures *via* the same consecutive reaction steps: (i) ethane dehydrogenation into ethene and hydrogen and (ii) benzene alkylation with ethene. Additionally, the reaction temperature affects the rates of the reaction steps, leading to different product distributions.

Chapter 6

Reaction Pathways

The reaction temperature analyses of benzene alkylation with ethane into EB and hydrogen over Pt-containing ZSM-5 catalyst were carried out in Chapter 5. The effects of temperature on the catalyst performances and the product distribution were established. It was observed that the benzene alkylation with ethane into EB and hydrogen over 1PtH-ZSM-5 catalyst is accompanied by formation of various side products. Hence, the subsequent optimisation of the reaction should focus on minimising the formation of side products, which could be done by adjusting the catalyst compositions. The detailed investigation of the reaction pathways was carried out, prior to the optimisation of the catalyst compositions, to clarify the reaction steps that need to be suppressed to achieve higher catalyst selectivity and stability.

6.1. Reaction steps at low contact time

The analysis of the reaction pathways of benzene alkylation with ethane into EB and hydrogen over 1PtH-ZSM-5 catalyst was carried out at 370°C as further optimisation would be carried out at the proposed optimum temperature. The formation of the reaction products is analysed at low and high contact times separately, as different reactions are taking place in these two regions.

In the region of low contact time, hydrogen, ethene, propane, EB, DEBs, toluene, and PBs were observed. Figure 6.1 depicts the concentration of these products as functions of contact time and demonstrates that hydrogen, ethene and EB are the main reaction products. The extrapolations of hydrogen and ethene curves to the origin suggest that ethene and hydrogen are the initial products, while EB, propane, PBs and toluene, which formed at specific contact time, are the products of the secondary reaction steps. Hence, as discussed in Chapter 5, the EB formation proceeds *via* two consecutive reaction steps: (i) ethane dehydrogenation into ethene and hydrogen on Pt sites (Eq. 6.1) and (ii) benzene alkylation with ethene into EB over Brønsted acid sites (Eq. 6.2). EB formation directly *via* benzene alkylation with ethane, which was proposed by Smirnov *et al.* (2000), does not take place under the reaction conditions used in this work.

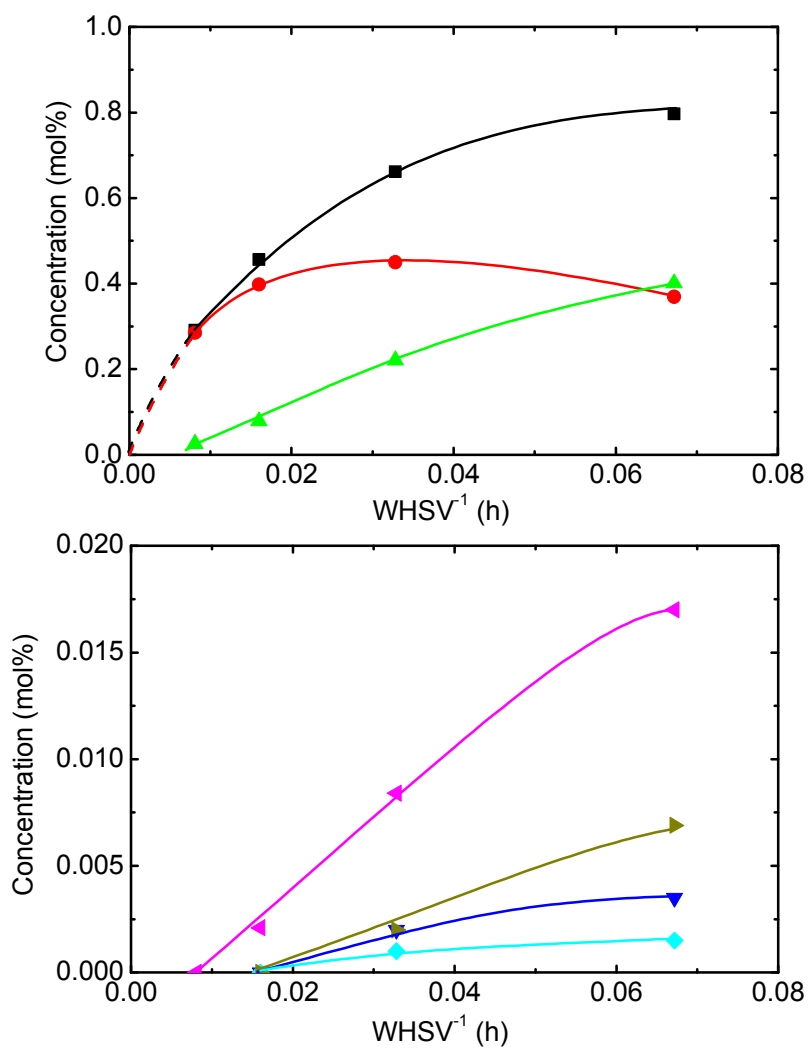
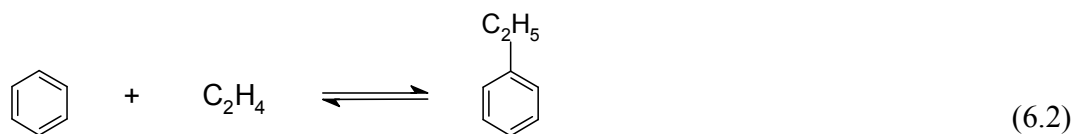
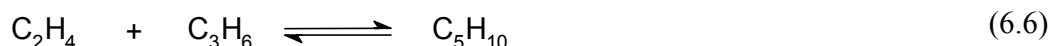
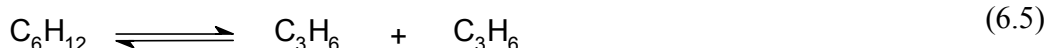
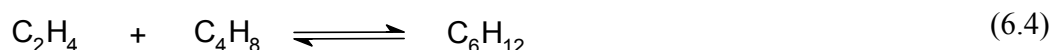

Figure 6.1. Effect of contact time on the concentrations of (■) H₂, (●) ethene, (▲) EB, (▼) propane, (◆) toluene, (◀) PBs, and (▶) DEBs formed during benzene alkylation with ethane over 1PtH-ZSM-5 catalyst at 370°C.

The low equilibrium ethane dehydrogenation conversion into ethene at 370°C leads to the low ethene concentration. The low ethene concentration hinders the acid catalysed

bimolecular ethene dimerisation steps (Eq. 6.3), which are the initial reaction steps in the sequence of alkene oligomerisation and cracking reactions. The alkene oligomerisation and cracking reactions produce different alkenes and the reactions for the formation of hexenes, propene and pentenes are illustrated as follows (Eqs. 6.4-6.6).



According to literature, alkene distribution resulting from the oligomerisation and cracking reactions is a strong function of alkene partial pressure and is shifted to small alkenes at low alkene concentrations. Therefore, the rates of alkene oligomerisation reaction as well as the formation of higher molecular weight alkenes are hindered at low ethene concentration (Quann *et al.*, 1988, Lukyanov and Vazhnova, 2008a). As a result, ethene and propene were observed in the reaction mixture at 370°C, and the formation of butene was determined at higher reaction temperature (450°C) at which higher ethene concentration was produced. Hence, the formation and distribution of butene isomers will not be discussed in this section.

EB, which formed from alkylation of benzene with ethene (Eq. 6.2), could be converted further into DEBs *via* alkylation of EB with ethene (Eq. 6.7). The further transformation of propene has led to the formation of propane *via* Pt catalysed hydrogenation reaction (Eq. 6.8) and to the formation of PB *via* acid catalysed benzene alkylation reaction (Eq. 6.9).

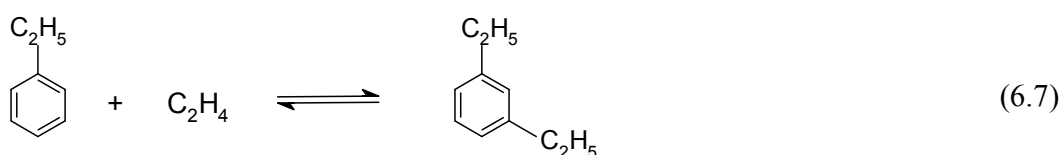

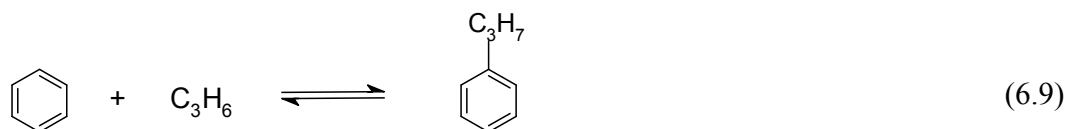

6.2. Reaction steps at high contact time

Figure 6.2 and 6.3 show the distributions of product of benzene alkylation with ethane at 370°C in the whole range of contact times used in this study. Additional products are observed in the reaction mixture as the contact time increases from 0.08 to 0.65 h: propene, butanes, xylenes, ethyltoluene, and other aromatics (Fig. 6.2b), TEB (Fig. 6.3a), methane and toluene (Fig. 6.3b). In addition to the formation of these products, a significant increase is observed for EB, hydrogen, PB, DEBs, and propane concentrations, while the ethene concentration passes through a maximum. Butanes are observed in traces (Fig. 6.2b) and are formed from hydrogenation of butene isomers (Eq. 6.10).



Figure 6.4 shows that n-butane is produced in larger amount than iso-butane and is suggested to form from the hydrogenation of the more favourable linear butenes (trans-butene, cis-butene and 1-butene). On the other hand, less favourable iso-butene hydrogenation reaction yielded iso-butane at higher contact time. The low rate of conversion of iso-butene might be attributed to the high stability of tertiary butyl group on the Pt surface. It should be noted that cis-butene and 1-butene undergo competing hydrogenation and isomerisation reactions; hence, large proportion of n-butane concentration is more likely to be contributed by the hydrogenation of trans-butene. The formation of methane could be associated with the formation of toluene *via* hydrogenolysis of EB (Eq. 6.11) and the hydrogenolysis of ethane into methane (Eq. 6.12) over Pt sites of the catalyst.

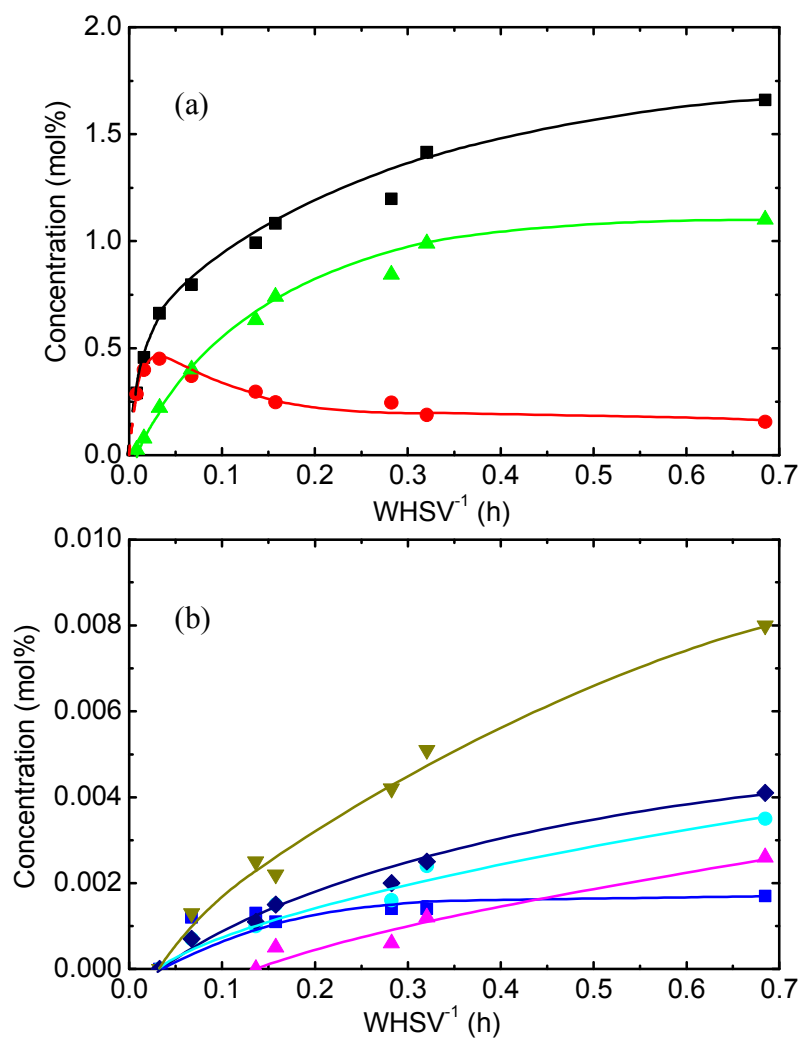
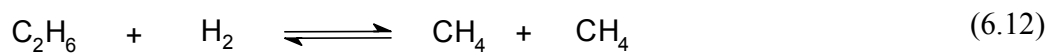
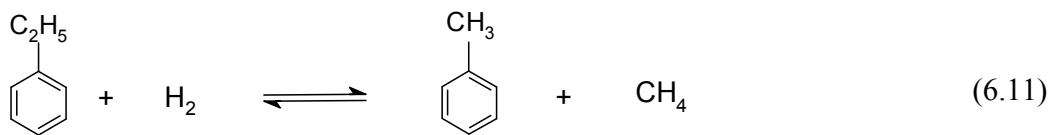

Figure 6.2. Effect of contact time on the concentrations of (■) H₂, (●) ethene, (▲) EB, (■) propene, (●) butanes, (▲) xylenes, (▼) ethyltoluene, and (◆) other aromatics formed during benzene alkylation with ethane over 1PtH-ZSM-5 catalyst at 370°C.

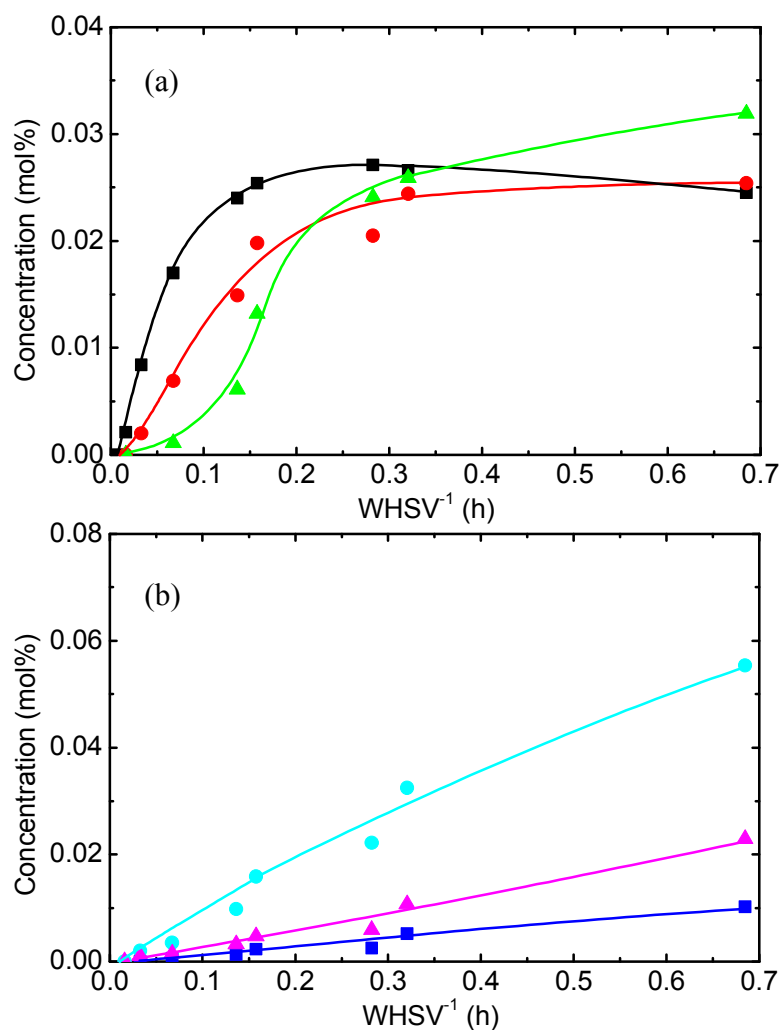
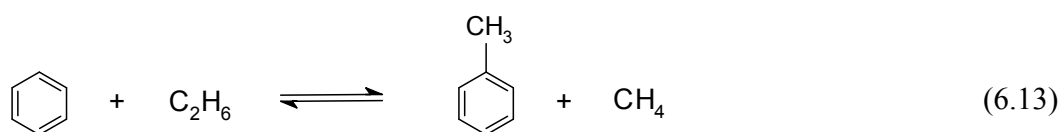
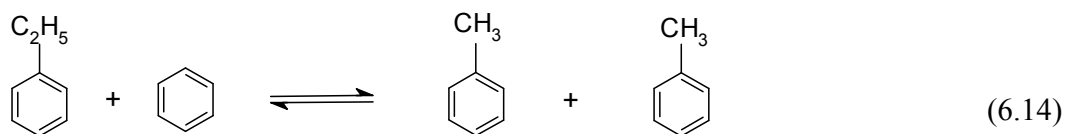

Figure 6.3. Effect of contact time on the concentrations of (■) PB, (●) DEBs, (▲) TEB, (■) methane, (●) propane, and (▲) toluene formed during benzene alkylation with ethane over 1PtH-ZSM-5 catalyst at 370°C.

However, taking into consideration that toluene is formed in higher amounts than methane (Fig. 6.3b), it is suggested that toluene is formed also from other reactions. Smirnov *et al.* (2001) proposed that toluene could be formed from benzene alkylation with ethane into methane and toluene (Eq. 6.13) and/or transalkylation of EB (Eq. 6.14).





The figure of toluene selectivity as a function of ethane conversion shows that toluene is one of the secondary products and suggesting that the direct alkylation of benzene with ethane into toluene and methane (Eq. 6.13) does not take place under the reaction conditions. The tertiary reaction, EB transalkylation into toluene (Eq. 6.14), could be favourable at high contact time, leading to high toluene concentration.

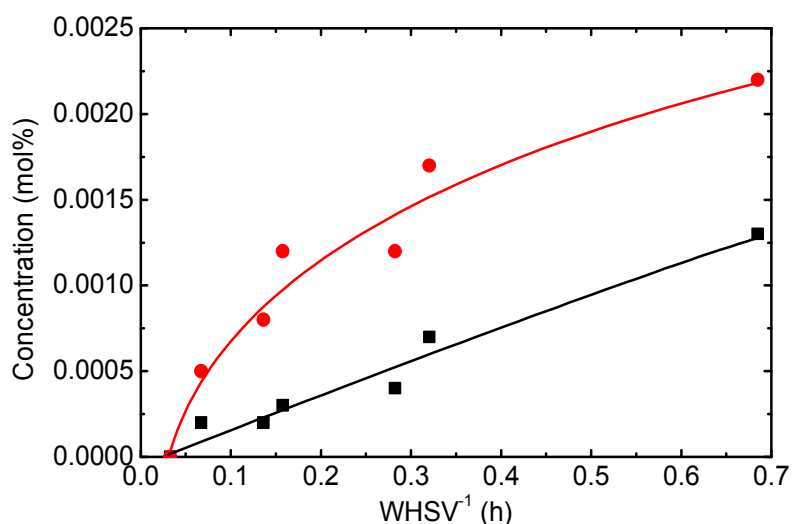
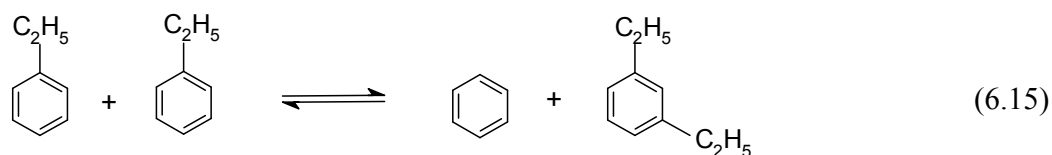

Figure 6.4. Effect of contact time on the concentrations of (■) iso-butane, and (●) n-butane formed during benzene alkylation with ethane over 1PtH-ZSM-5 catalyst at 370°C.

EB is transformed further into DEB *via* acid catalysed EB alkylation with ethene (Eq. 6.7) and disproportionation of EB (Eq. 6.15). The produced DEB, which is one of the intermediate products, would be alkylated further with ethene into TEB (Eq. 6.16 and Fig. 6.3a).



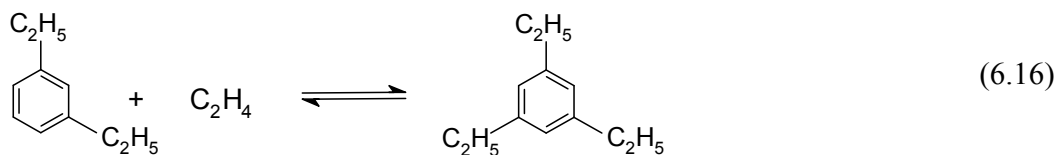

Figure 6.5 shows the distribution of DEB isomers in which meta-DEB (1,3-DEB) was produced in the highest concentration, followed by para-DEB (1,4-DEB), and ortho-DEB (1,2-DEB) was least produced. The product distribution of DEB isomers in the reactions over ZSM-5 zeolites catalysts is affected by the thermodynamic equilibrium, geometrical restrictions as well as the diffusional limitation, i.e. the differences in the diffusivities of various product molecules (Schumacher and Karge, 1999).

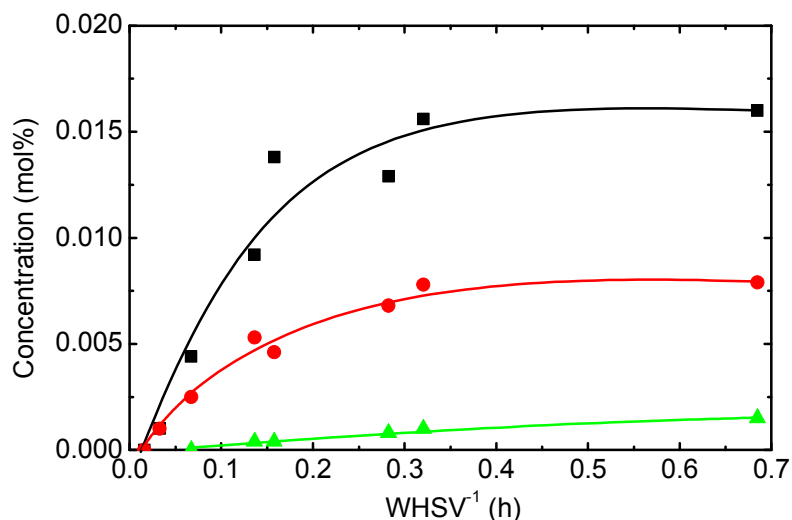

Figure 6.5. Effect of contact time on the concentrations of (■) 1,3-DEB, (●) 1,4-DEB and (▲) 1,2-DEB formed during benzene alkylation with ethane over 1PtH-ZSM-5 catalyst at 370°C.

The thermodynamic equilibrium of DEB isomers at 370°C is p:m:o = 29:52:19 while the ratio of DEB isomers, obtained experimentally, is p:m:o = 33:63:4 when the isomers distribution becomes stable (Fig. 6.5). The geometrical limitation could hinder the formation of ortho isomer; in addition to that, the low diffusivity of ortho isomer prevents the diffusion of 1,2-DEB through the zeolite channels. The low concentration of 1,2-DEB could be due to its low diffusivity in comparison with diffusivities of 1,3-

and 1,4-DEBs. As a result, the concentrations of 1,2-DEB are significantly lower compared to other isomers (1,3- and 1,4-DEBs) (Fig. 6.5). Similar result was obtained on 1,2-xylene (Fig. 6.6).

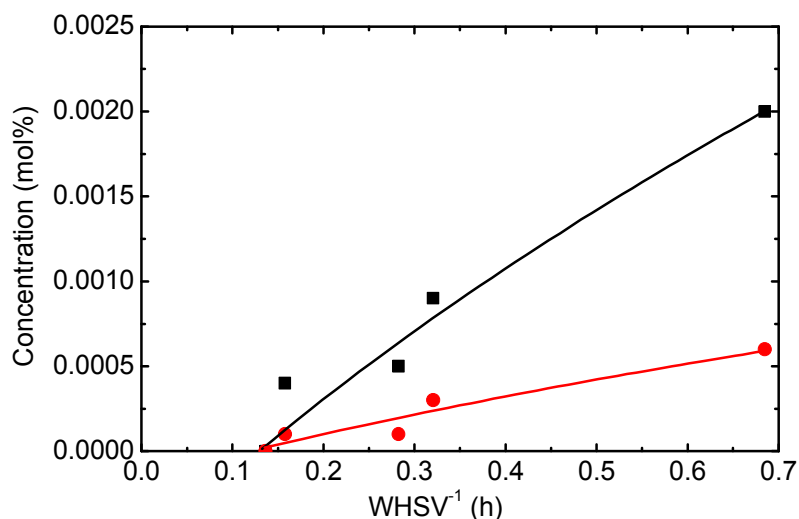
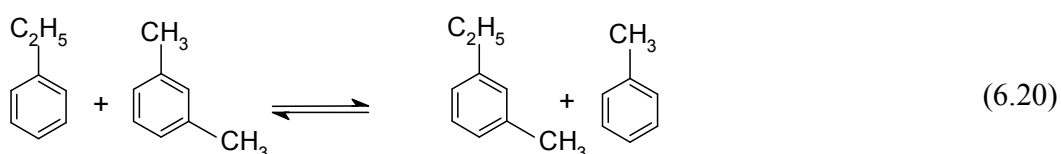
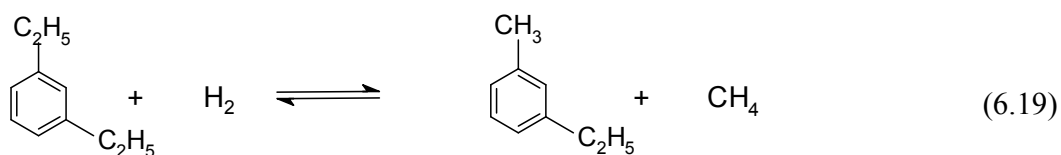
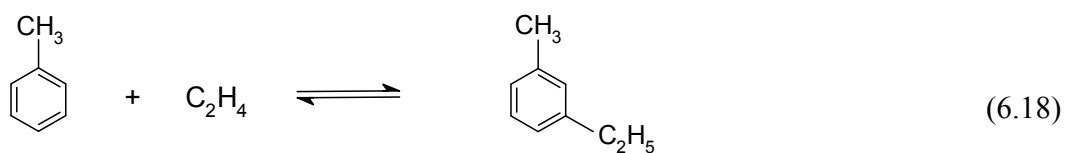

Figure 6.6. Effect of contact time on the concentrations of (■) 1,3- and 1,4-xylenes, and (●) 1,2-xylene formed during benzene alkylation with ethane over 1PtH-ZSM-5 catalyst at 370°C.

The formation of xylenes can be explained by EB hydroisomerisation reaction (Eq. 6.17) that proceeds *via* a sequence of reaction steps over Pt and acid sites (Lukyanov and Vazhnova, 2008a; Olson and Haag, 1984).



The formation of ethyltoluene is likely to occur *via* toluene alkylation with ethene over Brønsted acid site (Eq. 6.18), DEB hydrogenolysis over Pt sites (Eq. 6.19) and the transalkylation of EB with xylene into ethyltoluene and toluene (Eq. 6.20) (Moreau *et al.*, 2002)



In conclusion, the reaction pathways of benzene alkylation with ethane over bifunctional catalyst are established by the detailed investigation of the product distributions. Figure 6.7 summarizes the proposed reaction pathways of benzene alkylation with ethane into EB and hydrogen over 1PtH-ZSM-5 catalyst. The initial reaction of the benzene alkylation with ethane is the dehydrogenation of ethane on Pt sites forming intermediate product, ethene. Once ethene is produced, it alkylates benzene over Brønsted acid sites to form EB. The consecutive reaction steps involve the oligomerisation of ethene; the hydrogenolysis of ethane, the cracking of large alkenes formed from the oligomerisation reactions; the alkylation of benzene with propene producing PBs; and the isomerisation, hydrogenolysis, dialkylation, transalkylation and disproportionation of EB forming xylene isomers, toluene and methane, benzene and ethene, toluene, benzene and DEB, respectively. The tertiary reaction steps are the DEB alkylation with ethene and hydrogenolysis with H₂ which produce TEB and ethyltoluene and methane, respectively.

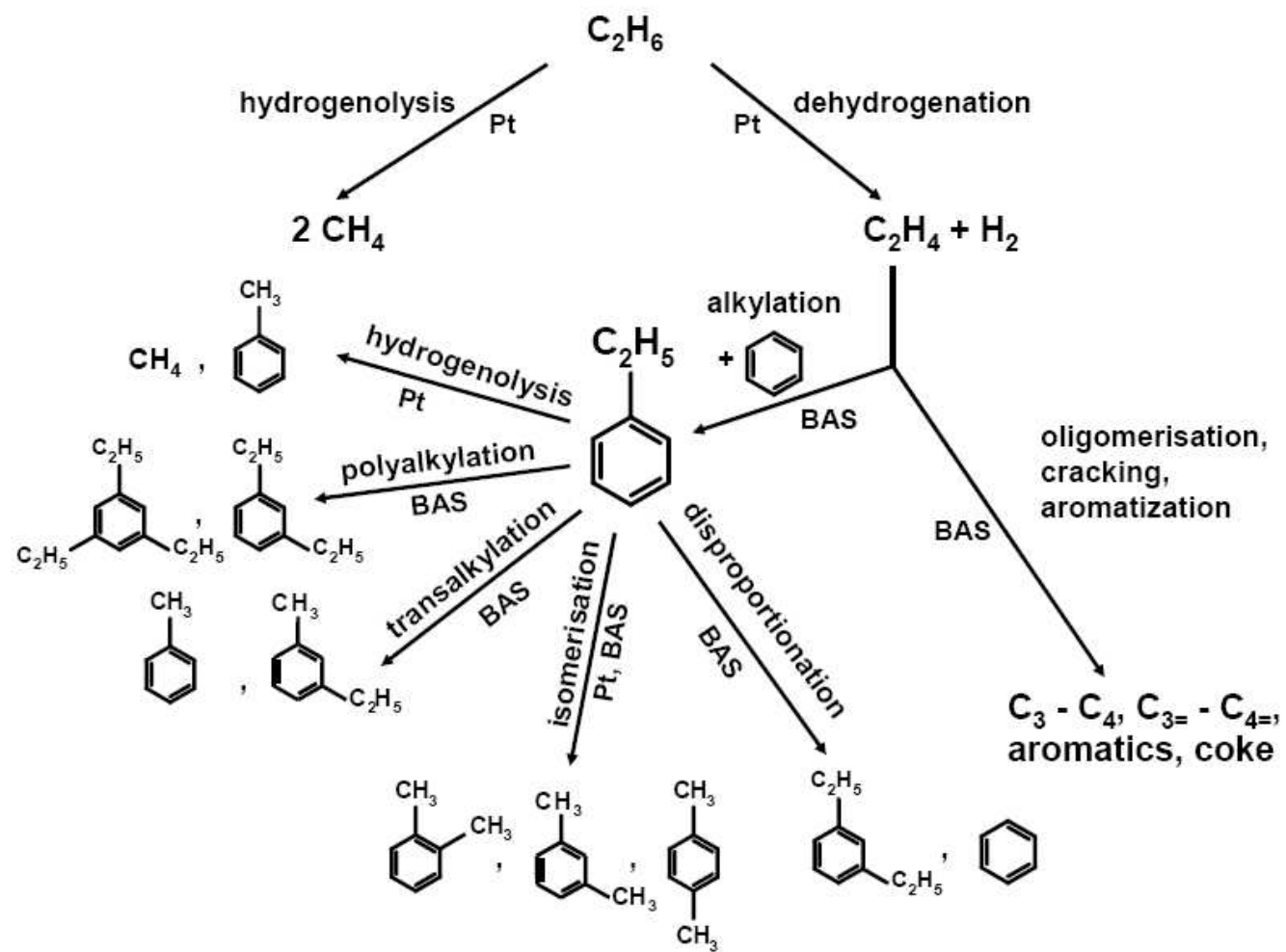

Figure 6.7. Reaction pathways of benzene alkylation with ethane into EB and hydrogen over 1PtH-ZSM-5 catalyst.

Chapter 7

Effect of Catalyst Compositions on Benzene Alkylation with Ethane into EB

As discussed in Chapter 1, the underlying idea of this project was to couple ethane dehydrogenation into ethene over metal sites with benzene alkylation with ethene over BAS using bifunctional catalyst. The efficiency of the EB formation should depend on the rates of ethane dehydrogenation (Eq. 5.1) and benzene alkylation with ethene into EB (Eq. 5.2). The rates of ethane dehydrogenation could be maintained low by operating the system at such low temperatures that the equilibrium conversions of ethane dehydrogenation into ethene are very low ($< 1\%$). The rate of benzene alkylation with ethene could be altered by the nature and number of metal sites and by the number of BAS in the catalyst (Lukyanov and Vazhnova, 2008a). As a result, the initial stage of the project focused on the establishment of the optimum reaction temperature for benzene alkylation with ethane into EB over Pt-containing ZSM-5 zeolite catalyst with moderate acidity ($\text{SiO}_2/\text{Al}_2\text{O}_3 = 80$). At this stage, the selection of catalyst compositions was based mainly on the available literature sources and no attempt was made to optimise further the catalyst composition at the first stage of the project.

PtH-ZSM-5(80) bifunctional catalyst was selected because Pt is known as a very good dehydrogenation catalyst with relatively low hydrogenolysis activity and ZSM-5 zeolites are used in the commercial EB production processes (Anderson, 1975; Corma, *et al.*, 2000). To the best of the author's knowledge, the bifunctional catalysts that have been involved in benzene alkylation with ethane and propane were in the range between 0.3 and 8.8 wt.% of Pt (Kato, *et al.*, 2001; Smirnov, *et al.*, 2000). The selected catalyst consists of moderate Pt loading (1wt.%) which could impose moderate Pt particle size, leading to high dispersion and moderate metal-support interaction, avoiding the suppression of dehydro/hydrogenation and hydrogenolysis reactions by the strong metal-support interaction (Meriaudeau, *et al.*, 1982; Den Otter, *et al.*, 1978; Shpiro *et al.*, 1991). Additionally, the zeolite of moderate acidity ($\text{SiO}_2/\text{Al}_2\text{O}_3 = 80$) was chosen to prevent the possible side reactions which could be favourable over highly acidic catalysts (Lukyanov and Vazhnova, 2008b).

The following stage of the project was focused on the determination of the promising catalyst based on the optimum temperature obtained at the first stage. The

benzene alkylation with ethane into EB was carried out over bifunctional catalysts of different Pt loading at 370°C. This investigation determines the effect of metal species on benzene alkylation with ethane, and establishes the promising bifunctional catalyst for the system. ZSM-5(72) zeolite was used in this series of experiments, due to the supply shortage of ZSM-5(80) after the temperature analysis. Hence, the preliminary analysis was carried out, prior to this series of experiments, to justify the comparability of ZSM-5(80) and ZSM-5(72) catalysts.

7.1. Preliminary analysis of PtH-ZSM-5(80) and PtH-ZSM-5(72)

Benzene alkylation with ethane into EB over 1PtH-ZMS-5(72) catalyst was carried out at various catalyst loadings and temperatures, and the catalytic results were compared with those obtained with 1PtH-ZMS-5(80) catalyst. Figure 7.1 shows that 1PtH-ZMS-5(72) yielded nearly 8% of benzene conversion, which is comparable to the benzene conversion obtained over 1PtH-ZMS-5(80) under the same reaction conditions. Additionally, both catalysts have converted similar amount of ethane (Fig. 7.1).

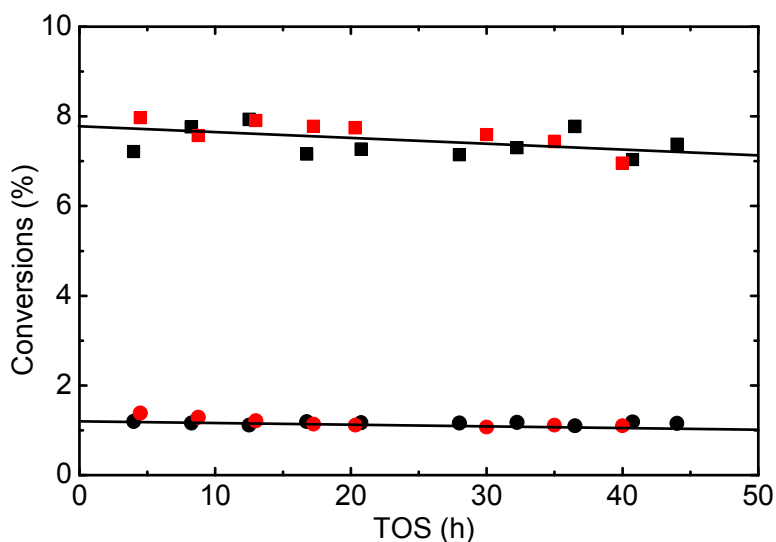

Figure 7.1. Effects of time on stream on (■) benzene and (●) ethane conversions over 1PtH-ZMS-5(80), and (■) benzene and (●) ethane conversions over 1H-ZMS-5(72) at 370°C, WHSV = 8.33 h⁻¹.

Figure 7.1 proved that both catalysts exhibit identical stability at 0.12 h of contact time. Figure 7.2 depicts identical benzene and ethane conversions as a function of contact time for 1PtH-ZMS-5(80) and (72) catalysts. This indicates that the slight difference in the catalyst acidity affects neither the catalyst stability nor the catalyst activity for benzene alkylation with ethane into EB at 370°C. Table 7.1 shows the product distribution of benzene alkylation with ethane into EB over 1PtH-ZMS-5(80) and (72) catalysts at different contact times.

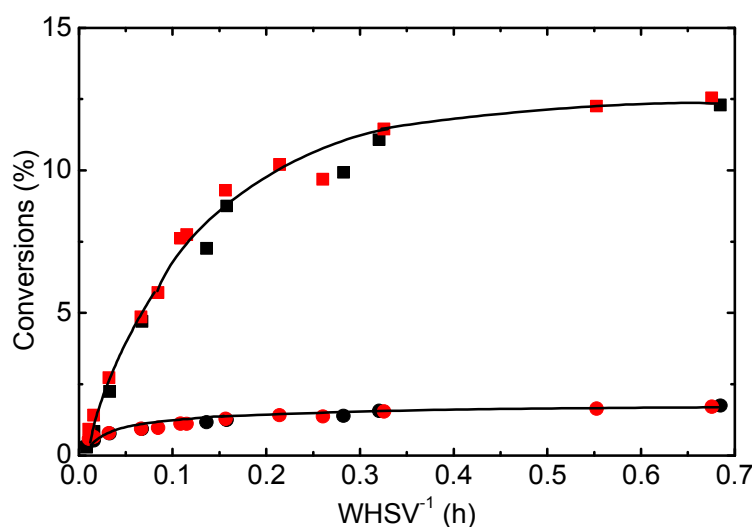

Figure 7.2. Effects of contact time on (■) benzene and (●) ethane conversions over 1PtH-ZMS-5(80), and (■) benzene and (●) ethane conversions over 1PtH-ZMS-5(72) at 370°C.

At 0.07 h of contact time, almost all product selectivities are identical for both catalysts and only about 2 mol.% difference in the ethene and EB selectivities were observed. At high contact time ($\tau = 0.32$ and 0.68 h) only TEBs selectivity in all carbon containing products demonstrated slight dissimilarity over 1PtH-ZMS-5(80) and (72) catalysts. These slight differences in product distribution over 1PtH-ZMS-5(80) and (72) catalysts are insignificant and the experimental data has shown that both catalysts demonstrate identical catalyst activity and stability. As a result, the series of experiments for the optimisation of catalyst composition was carried out using H-ZSM-5(72) which can be easily related to the temperature analyses.

Table 7.1. Selectivities to all carbon containing products of benzene alkylation with ethane over two 1PtH-ZSM-5 catalysts at 370°C, TOS = 20-24 h.

WHSV ⁻¹ (h)	0.07		0.32		0.68	
SiO ₂ /Al ₂ O ₃	80	72	80	72	80	72
Benzene conversion (%)	4.71	4.87	11.08	11.47	12.29	12.64
Ethane conversion (%)	0.91	0.94	1.57	1.54	1.75	1.74
Selectivities (mol.%)						
Methane	0.08	0.00	0.39	0.70	0.71	0.88
Ethene	45.76	43.45	14.27	14.12	10.70	11.15
Propane	0.44	0.56	2.47	2.80	3.83	3.87
Propene	0.14	0.13	0.11	0.10	0.12	0.12
Butanes	0.08	0.00	0.18	0.20	0.24	0.23
Butenes	0.00	0.00	0.00	0.00	0.00	0.00
Toluene	0.18	0.14	0.82	0.81	1.58	1.38
Ethylbenzene	49.67	52.49	75.33	75.37	76.12	76.17
Xylenes	0.00	0.00	0.09	0.06	0.19	0.16
Propylbenzenes	2.11	2.26	2.05	2.00	1.72	1.72
Ethyltoluenes	0.16	0.05	0.39	0.35	0.55	0.47
Diethylbenzenes	0.86	0.80	1.86	1.74	1.75	1.68
Triethylbenzenes	0.13	0.00	1.97	1.60	2.21	1.96
Others	0.38	0.12	0.07	0.15	0.28	0.21

7.2. Effect of metal species on benzene alkylation with ethane into EB

It is well agreed that the benzene alkylation with light alkanes into alkylbenzenes over metal containing bifunctional catalyst involves the dehydrogenation of light alkane into light alkene and hydrogen, which is catalysed by the metal species, followed by the benzene alkylation reaction on the acid sites (Abdul Hamid *et al.*, 1996; Krogh *et al.*, 2003; Lukyanov and Vazhnova, 2008). As a result, the metal species of the bifunctional catalyst plays an important role as it catalyses the ethane dehydrogenation into ethene and hydrogen, which would affect the rate of the subsequent reaction, i.e. benzene alkylation with ethene into EB.

7.2.1. Effect of metal species on catalyst activity

Figure 7.3 shows the catalyst activity of pure H-ZSM-5 and Pt-loaded (1 wt.%) ZSM-5 catalysts in the alkylation of benzene with ethane into EB at 370°C. The unloaded H-ZSM-5 catalyst, which according to Kato *et al.* (2001) exhibited high catalytic activity in the benzene alkylation with ethene, afforded very low ethane

conversion. This proposes that the light alkane could be converted, on the H-ZSM-5 catalyst, *via* the two acid catalysed routes: (i) monomolecular protolytic cracking route and (ii) bimolecular hydrogen transfer route (Caeiro *et al.*, 2006; Guisnet *et al.*, 1992; Haag and Dessau, 1984; Lukyanov *et al.*, 1995; Nguyen *et al.*, 2006). Additionally, practically no changes were observed in ethane conversion at 0.6 h of contact time, illustrating that the acid catalysed routes are not favourable over the pure H-ZSM-5 catalyst at 370°C. At 0.15 h of contact time, the ethane conversion increased from 0.03 to 1.28% when 1 wt.% of Pt was incorporated into ZSM-5 catalyst. The ethane conversion improved dramatically over 1PtH-ZSM-5 catalyst, suggesting that the incorporation of Pt provides an additional reaction route, ethane dehydrogenation, which has enhanced significantly the transformation of ethane. The ethane conversion increased from 0.6 to 1.28% at the initial 0.15 h of contact time, proposing that ethane is converted mainly *via* ethane dehydrogenation over Pt sites, i.e. the dehydrogenating component. The rise of ethane conversion became less pronounced at high contact time which is evidenced by the slight increase of ethane conversion from 1.28 to 1.54% over the next 0.15 h of contact time. This suggests that the ethane dehydrogenation into ethene and hydrogen is a reverse reaction and the reverse ethene hydrogenation reaction takes place at high contact time and hence, limiting the ethane transformation.

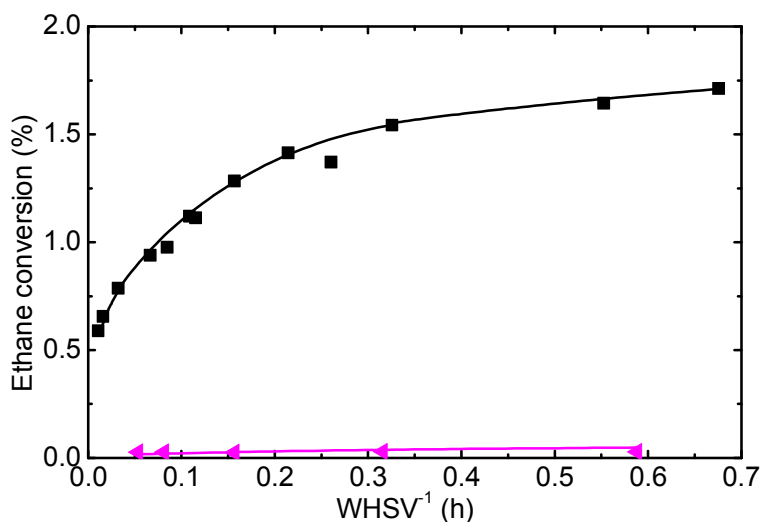

Figure 7.3. Effects of contact time on ethane conversion during benzene alkylation with ethane over (■) 1PtH-ZMS-5(72), and (◄) H-ZMS-5(72) at 370°C.

Smirnov *et al.* (2000) observed that the conversion of benzene alkylation with propane into iPB over H-ZSM-5 remains rather low in the temperature range of 300-400°C. Further increase of the reaction temperature leads to the significant rise in activity, and the conversions of benzene and propane achieved 37 and 63% at 500°C, respectively. Additionally, the total propane conversion during benzene alkylation with propane over H-ZSM-5(100) was 0.32% ($WHSV^{-1} = 0.7$ h) at 350°C and the propane conversion rose to 0.86% when zeolite with higher acidity was used, i.e. H-ZSM-5(50). It should be noted that the ethane molecule consists of only primary C-H bonds, and propane has two weaker secondary bonds which render propane more reactive and easier to be activated than ethane (Fogler, 2006). Singer *et al.* (2007) indicates that the use of the less reactive ethane as an alkylating agent for benzene on bifunctional zeolite catalysts results in lower conversions than with propane; however, a higher selectivity to the primary alkylation product, EB, can be achieved.

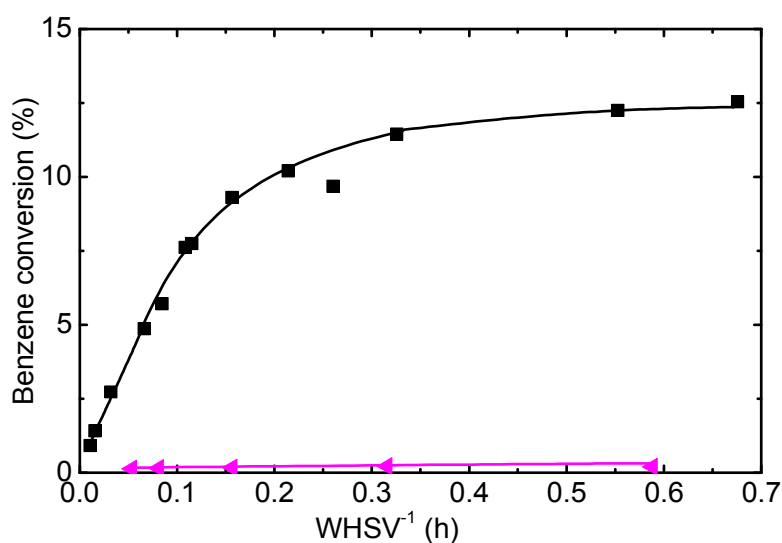

Figure 7.4. Effects of contact time on benzene conversion over (■) 1PtH-ZMS-5(72), and (◄) H-ZMS-5(72) at 370°C.

Figure 7.4 shows that the benzene conversion over H-ZSM-5 catalyst was about 0.2% at 0.3 h of contact time and the incorporation of 1 wt.% of Pt has led to the dramatic rise in benzene conversion to 11.5%. The enhancement of ethane conversion on Pt-loaded acid catalyst could lead to higher ethene concentration and hence

improving the benzene transformation with ethene into EB. On the other hand, the H-ZSM-5 catalyst, which yielded very low ethane conversion, hindered the subsequent reaction, i.e. benzene alkylation with ethene into EB. As a result, the rate-limiting step of benzene alkylation with ethane into EB over pure acidic H-ZSM-5 catalyst is likely to be the primary reaction step, i.e. ethane transformation into ethene and hydrogen.

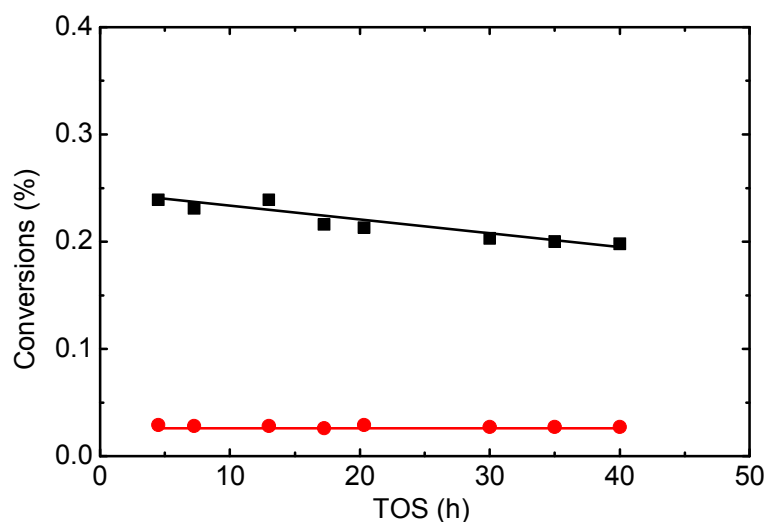

Figure 7.5. Effects of time on stream on (■) benzene and (●) ethane conversions over bare H-ZMS-5(72) at 370°C, WHSV = 8.33 h⁻¹.

Figure 7.5 depicts no change in ethane conversion over 40 h on stream while the benzene conversion dropped slightly from 0.24 to 0.20%. The decrease in benzene conversion is more likely due to the experimental error rather than the catalyst deactivation, as observed at high temperatures. The catalyst deactivation at high temperatures could be due to the enhanced formation of coke which was evidenced by the formation of large amounts of C₁₀-C₁₂ aromatics and naphthalene. These products were not detected in benzene alkylation with ethane over H-ZSM-5 catalyst, and hence, the catalyst deactivation is unlikely be the cause of the slight decrease in benzene conversion (Fig. 7.5).

7.2.2. Effect of metal species on product distribution

The previous section has shown that the incorporation of Pt affects significantly the feed conversions. The ethane conversion improved dramatically with the incorporation of Pt (Fig. 7.3), suggesting that the Pt provides an additional route for the transformation of ethane, i.e. ethane dehydrogenation into ethene and hydrogen on Pt sites. The increase of ethene concentration over 1PtH-ZSM-5 has encouraged the consecutive reaction, benzene alkylation with ethene into EB, and hence higher benzene conversion was observed on the Pt loaded catalyst (Fig. 7.4). The incorporation of Pt affects the ethane conversion routes, leading to the enhanced transformation of benzene.

As discussed in the previous chapter the benzene alkylation with ethane into EB over 1PtH-ZSM-5 catalyst proceeds with high stability and selectivity, and yields nearly 15 different products at 370°C. On the other hand, the benzene alkylation with ethane over H-ZSM-5 produced very small amount of hydrogen, ethene, n-butane, toluene, EB and iPB. This is in agreement with the observation by Ivanova *et al.* (1996) and Bigey and Su (2004) that the benzene alkylation with propane over H-ZSM-5 catalyst exhibits very low catalyst activity at reaction temperature lower than 500°C. It is generally agreed that the introduction of hydro/dehydrogenation components into acidic zeolite catalyst promotes the rate of the transformation of light alkanes. Caeiro *et al.* (2006) indicated that alkane transformation over bifunctional catalysts could proceed through a bifunctional reaction scheme, and is complex in terms of reaction scheme and catalyst system.

Figure 7.6a shows that the hydrogen concentration improved significantly with the incorporation of Pt into H-ZSM-5 catalyst. The change of hydrogen concentration with the contact time (Fig. 7.6a) coincides with the change of ethane conversion with contact time (Fig. 7.3). The hydrogen concentration increased from 0.5 to 1.2 mol.% over the first 0.15 h of contact time, then the rise became less pronounced that the hydrogen concentration increase from 1.2 to 1.4 mol.% between 0.15 and 0.32 h of contact time.

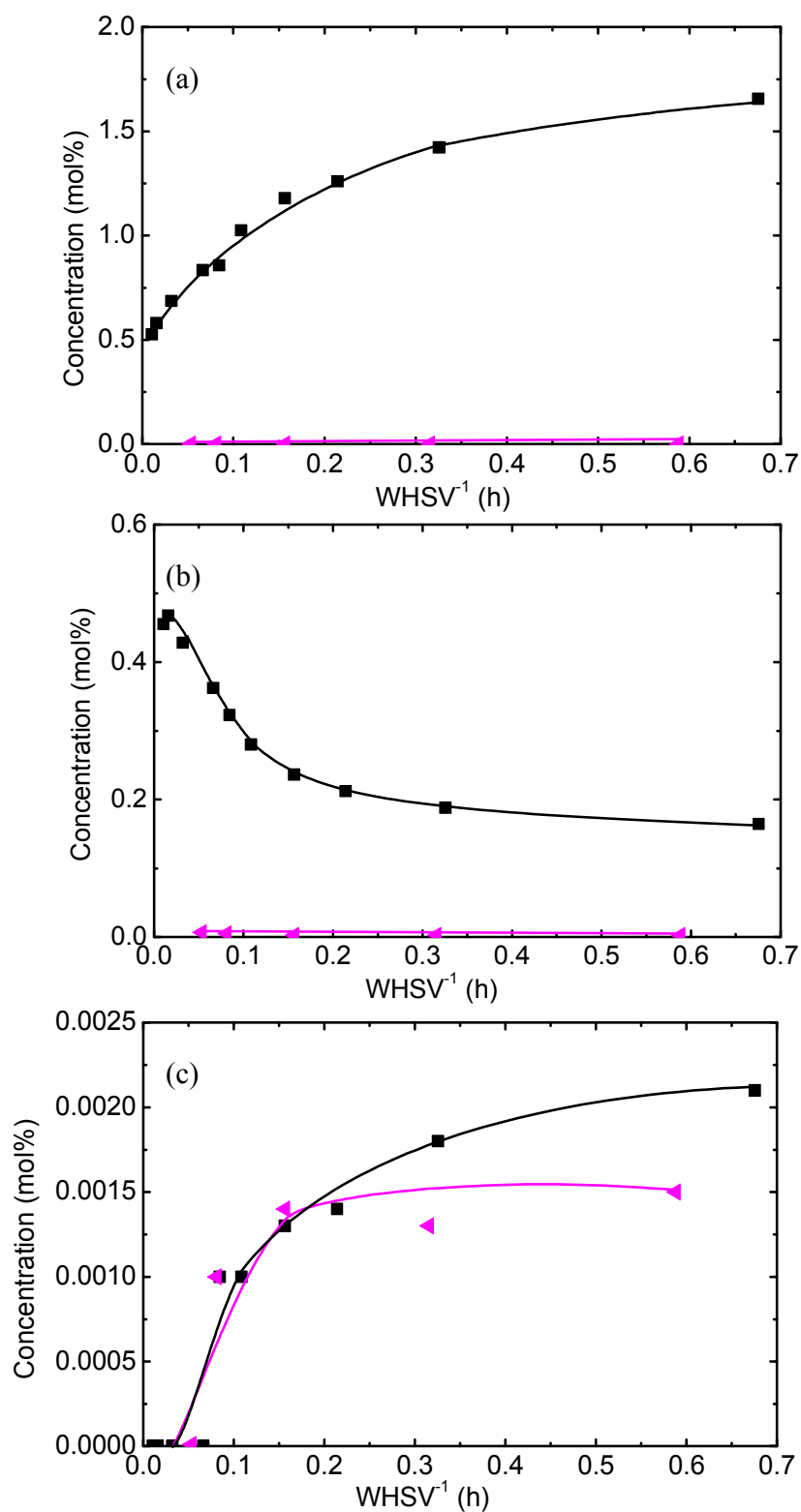

Figure 7.6. Effect of contact time on (a) H₂, (b) ethene, (c) butanes concentrations over (■) 1PtH-ZMS-5(72), and (◄) H-ZMS-5(72) at 370°C.

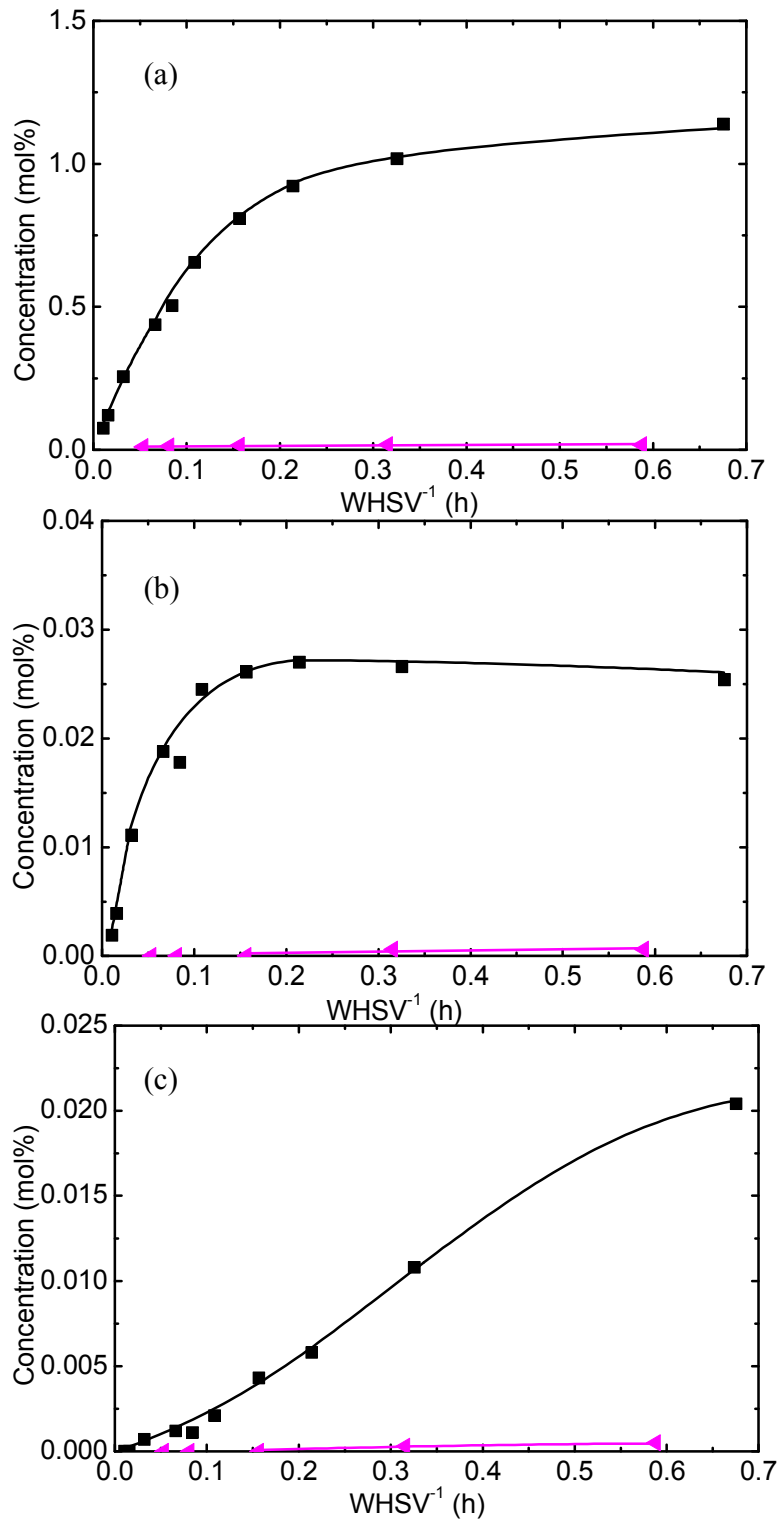

Figure 7.7. Effect of contact time on (a) EB, (b) iPB, (c) toluene concentrations over (■) 1PtH-ZMS-5(72), and (◄)H-ZMS-5(72) at 370°C.

Hence, the data in Figure 7.6a confirms that the hydrogen is one of the products of ethane dehydrogenation which its concentration increases as a result of the enhanced transformation of ethane into ethene and hydrogen by the incorporation of Pt into H-ZSM-5 zeolite. Nguyen *et al.* (2006) commented that the metal species has provided additional dehydrogenation routes for the alkane conversion into corresponding alkene and for the transformation of alkenes into aromatics and hydrogen. The aromatisation reactions, which produce hydrogen, are favourable at high contact time and hence the slight increase of hydrogen concentration at high contact time could be contributed from the aromatisation reactions.

The H-ZSM-5 catalyst produced low concentration of hydrogen and the concentration remained constant with increasing contact time (Fig. 7.6a). This indicates further that the H-ZSM-5 is not active in benzene alkylation with ethane into EB at 370°C. Figure 7.3 illustrates that the ethane is transformed in small amount on H-ZSM-5 catalyst, suggesting that the initial ethane activation, which is performed by the acid catalysed routes, is not favourable on the H-ZSM-5 catalyst at 370°C. As a result, the bimolecular ethene dimerisation steps, which are the initial reaction steps of the aromatisation reactions, become less favourable, hindering the aromatisation reactions. Hence, the hydrogen concentration remained constant even though at high contact time.

Figure 7.6b depicts that the ethene concentration is increased significantly with the incorporation of Pt into the H-ZSM-5 catalyst. Ethene, which is produced over Pt-loaded catalyst, reached a maximum at low contact time before dropping dramatically from 0.5 to 0.2 mol.% within 0.015 and 0.2 h of contact time. The Pt has provided an additional dehydrogenation route for the transformation of ethane, as a result, ethene is observed in large amount in benzene alkylation with ethane catalysed by 1PtH-ZSM-5 catalyst. The ethene concentration started to drop at 0.015 h of contact time suggesting that ethene could be consumed by consecutive reactions especially by the benzene alkylation reaction forming EB. Figure 7.7a shows that the EB concentration produced by Pt-containing catalyst increased dramatically between 0.015 and 0.2 h, which supports the proposal that the drop of ethene concentration with contact time is associated with the

alkylation of benzene with ethene into EB. The drop of ethene concentration becomes less pronounced at high contact time where the concentration dropped from 0.2 to 0.16 mol.% between the contact time of 0.2 and 0.67 h. On the other hand, the EB concentration increased slightly within the same range of contact time. Hence, the change in ethene concentration with contact time is highly dependent on the rate of benzene alkylation with ethene. Additionally, the relatively low concentration of ethene at high contact time could be due to the consumption of ethene by reactions which are favourable at high contact time, such as aromatisation reactions.

Figure 7.7a shows the EB concentration as a function of contact time and demonstrates that the EB concentration was increased significantly by the incorporation of Pt. The enhanced formation of EB on 1PtH-ZSM-5 catalyst is likely to be due to the improvement of the transformation of ethane by the additional ethane dehydrogenation route. Hence, more ethene is available for the alkylation reaction to form EB. The EB concentration rose dramatically over the initial 0.2 h of contact time, i.e. from 0.08 to 0.9 mol.%, then the rise becomes less pronounced, and the EB concentration increased from 0.9 to 1.1 mol.% between 0.2 and 0.67 h of contact time. The formation of EB is limited by the thermodynamic equilibrium, and the reverse dealkylation of EB into benzene and ethene takes place at high contact time, converting the EB. The low EB concentration that formed over H-ZSM-5 catalyst could be due to the low ethene concentration as discussed above.

The decrease of ethene concentration with increasing contact time is not as pronounced over H-ZSM-5 catalyst (Fig. 7.6b). The drop of ethene concentration from 0.007 to 0.003 mol.% over 0.6 h of contact time could be due to the consumption of ethene by alkylation of benzene with ethene into EB. This is supported by the rise in EB concentration from 0.01 to 0.02 mol.% over 0.6 h of contact time (Fig. 7.7a). On the other hand, slight amount of ethene could be converted *via* oligomerisation and hydrogenation reactions forming n-butane which is observed in traces over H-ZSM-5 catalyst (Fig. 7.6c). The n-butane was observed at 0.05 h of contact time indicating that n-butane is the secondary product which is formed from the consecutive reactions.

Identical and small amount of n-butane was formed over both catalysts at contact time lower than 0.2 h suggesting that the formation of n-butane is not favourable and is not affected by the incorporation of the Pt into H-ZSM-5 zeolite. Hence, n-butane could be transformed *via* acid catalysed route at low contact time. On the other hand, the Pt-loaded ZSM-5 catalyst, which exhibits higher catalyst activity, converts ethene preferable *via* oligomerisation, cracking and aromatisation reactions into various side products, as discussed in Chapter 5.2. The inactive H-ZSM-5 catalyst, would convert further the small amount of ethene *via* bimolecular ethene dimerisation steps and hydrogen transfer to form n-butane, and further reactions, such as oligomerisation, cracking and aromatisation reactions, could be hindered by the low activity of H-ZSM-5 catalyst.

The incorporation of Pt into H-ZSM-5 catalyst has improved the catalyst activity, leading to higher transformation of ethane and benzene. However, this is accompanied by various side products. Figures 7.7b and 7.7c show the side aromatic products, iPB and toluene, were formed in large amount in benzene alkylation with ethane over 1PtH-ZSM-5 catalyst. Toluene that formed over H-ZSM-5 catalyst could be produced from the acid catalysed transalkylation of EB and benzene forming 2 molecules of toluene, as shown in Eq. 2.3 (Smirnov *et al.*, 2001). This explains the observation of traces of toluene over H-ZSM-5 catalyst at high contact time (Fig. 7.7c). The incorporation of Pt has provided an additional route for the transformation of EB, i.e. EB hydrogenolysis into toluene and methane on Pt site (Moreau *et al.*, 2002). Additionally, more EB is available for the secondary transformation of EB over Pt-containing catalyst. As a result, the formation of toluene over Pt-containing H-ZSM-5 catalyst started at relatively low contact time and yielded larger amount of toluene. The high concentration of iPB over Pt loaded catalyst could be attributed to the high catalyst activity which has formed various light alkenes as a result of oligomerisation and cracking reactions.

In conclusion, the incorporation of Pt into H-ZSM-5 catalyst improved significantly the transformation of ethane by providing an additional Pt catalysed route, ethane dehydrogenation into ethene and hydrogen, leading to higher conversion of

benzene into EB. On the other hand, the high catalyst activity is accompanied by the formation of various side products which could reduce the EB selectivity. The next section will focus on the effects of metal loadings on catalyst performances as well as on the establishment of promising catalyst for benzene alkylation with ethane into EB at 370°C.

7.3. The selection of promising catalyst

The incorporation of Pt into H-ZSM-5 has provided the bifunctional reaction pathways for the transformation of ethane, subsequently leading to higher ethane and benzene conversions, as evidenced from previous section. Additionally, the Pt species affect the rate of reaction steps of benzene alkylation with ethane leading to different product distributions. It was discussed that the benzene alkylation with ethane into EB over PtH-ZSM-5 bifunctional catalyst proceeds in two consecutive reaction steps: (i) ethane dehydrogenation into ethene and hydrogen on Pt sites and (ii) benzene alkylation with ethene into EB on the acid sites. Hence, the reactivity and selectivity of bifunctional catalysts could be improved by the optimum balance between the dehydrogenating and acidic functions of the bifunctional catalyst (Caeiro *et al.*, 2006; Canizares *et al.*, 2001).

The acidic function optimisation was carried out on benzene alkylation with ethane into EB over PtH-ZSM-5 catalysts of low ($\text{SiO}_2/\text{Al}_2\text{O}_3 = 280$), moderate ($\text{SiO}_2/\text{Al}_2\text{O}_3 = 72$), and high ($\text{SiO}_2/\text{Al}_2\text{O}_3 = 30$) acidity (Lukyanov and Vazhnova, 2008a and 2008b). The results show that the catalyst with moderate acidity yielded stable catalyst performance as well as high catalyst activity and selectivity. The further optimisation of the catalyst was carried out in this project and focused on the amount of Pt incorporated into ZSM-5 of moderate acidity to investigate the effects of Pt content of the bifunctional catalyst on the catalyst performance, and hence determining the promising catalyst for benzene alkylation with ethane into EB. It was suggested that the efficiency of the Pt species in de/hydrogenation reactions is a complex interplay of various factors, such as the Pt dispersion, metal-support interaction, Pt particle size, etc. These factors are affected by the catalyst preparation procedures and the pre-treatment conditions,

such as the pre-treatment temperature and the gaseous environment (Anderson, 1975, M'Kombe *et al.*, 1997 and Shpiro *et al.*, 1991).

7.3.1. The effect of Pt loading on catalyst performance

The benzene alkylation with ethane into EB was carried out at 370°C over Pt-containing ZSM-5 catalysts with Pt loading ranging from 0.01 to 1 wt.%. Figure 7.9 demonstrates no changes in ethane conversions, during 20 h on stream, with 100 mg of 0.025, 0.1, 0.5, and 1 wt.%PtH-ZSM-5 catalysts. This suggests that the Pt-containing catalysts of Pt content higher than 0.025 wt.% yielded stable catalyst performance at 370°C. On the other hand, the ethane conversion dropped from 0.45 to 0.32 % during 20 h on stream over 0.01PtH-ZSM-5 catalyst. The ethane conversion increased with increasing Pt loadings, while the catalysts with 0.5 and 1 wt.% Pt yielded identical ethane conversion (Fig. 7.8).

Figure 7.9 shows that the benzene conversions remained constant during 20 h on stream for the catalysts with 0.025, 0.1, 0.5 and 1 wt.% of Pt, while the benzene conversion decreased slightly, from 2 to 1.6%, over 0.01PtH-ZSM-5 catalyst. Figures 7.8 and 9 show that the ethane and benzene conversions increase with increasing Pt loadings and the catalysts with 0.5 and 1 wt.% Pt have converted identical amounts of ethane and benzene, revealing that the further increase in Pt loading from 0.5 to 1 wt.% improved neither the feed conversions nor the catalyst stability.

The relatively low catalyst stability which was observed over 0.01PtH-ZSM-5 catalyst could be due to the limited amount of active metal sites. The first step of benzene alkylation with ethane into EB is the ethane dehydrogenation into ethene and hydrogen, followed by the alkylation of benzene with ethene into EB. As a result, the formation of EB would depend on the rate of ethane dehydrogenation, which is affected by the active metal species. The efficiency of ethane dehydrogenation reaction is directly affected by the amount of active metal species as it is not a structure sensitive reaction which takes place on some special sites of the catalyst (Marecot *et al.*, 1989; Raddi *et al.*, 2000).

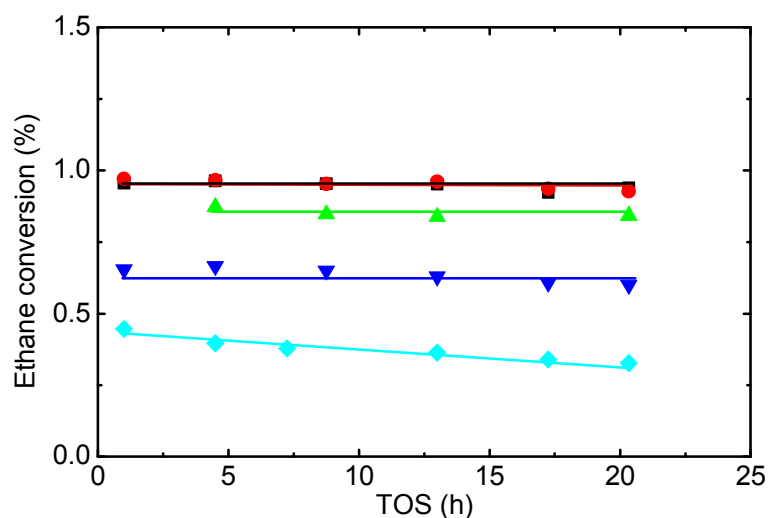

Figure 7.8. Effect of time on stream on ethane conversion over (■) 1, (●) 0.5, (▲) 0.1, (▼) 0.025, and (◆) 0.01PtH-ZSM-5 at 370°C, WHSV = 15.5 h⁻¹.

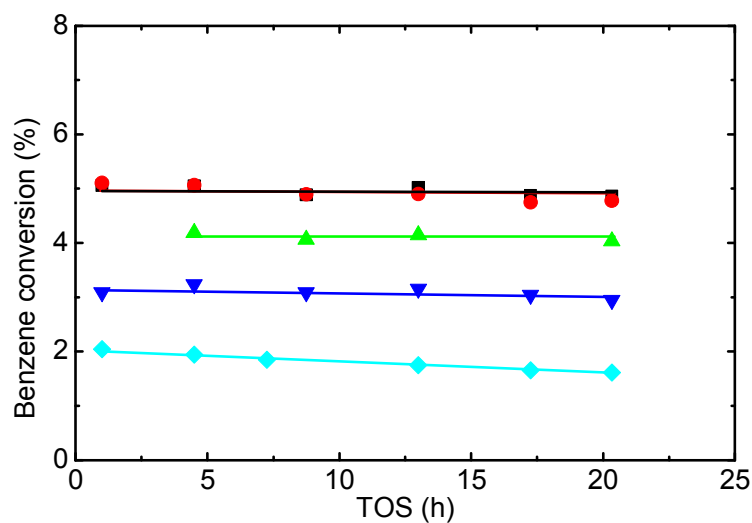

Figure 7.9. Effect of time on stream on benzene conversion over (■) 1, (●) 0.5, (▲) 0.1, (▼) 0.025, and (◆) 0.01PtHZSM-5 at 370°C, WHSV = 15.5 h⁻¹.

0.01PtH-ZSM-5 contained limited amount of active metal sites due to small Pt loading. Table 7.2 shows extremely low number of active Pt species in the 0.01PtH-ZSM-5 catalyst. When the reaction started, the ethane dehydrogenation takes place on the active metal sites and some Pt active site could be poisoned by coke and become

inactive. Hence, the number of active Pt site in the 0.01PtH-ZMS-5 catalyst could drop, over the course of reaction. This could cause the decrease in ethane conversion over the course of reaction as observed in Figure 7.8. The drop in ethane conversion leads to the drop in ethene concentration, and the decrease in benzene conversion (Fig. 7.9), as benzene is converted mainly *via* alkylation of benzene with ethene into EB.

Table 7.2. Platinum dispersion and number of active platinum sites in PtH-ZSM-5 catalysts with 0.01 to 1 wt.% of Pt (these results were provided by Dr. Paul Millington at Johnson Matthey Technology Centre, Sonning Common).

Catalysts	D _{Pt} (%)	Number of active Pt site (mol/g)
1PtH-ZSM-5	10	5.1×10^{-6}
0.5PtH-ZSM-5	19	4.9×10^{-6}
0.1PtH-ZSM-5	90	4.6×10^{-6}
0.025PtH-ZSM-5	100	1.3×10^{-6}
0.01PtH-ZSM-5	100	5.1×10^{-7}

On the other hand, stable catalyst performances are observed with catalysts with higher Pt loadings and this could be due to the higher number of active metal sites. Similarly, some Pt active sites could be poisoned and become inactive over the course of reaction. Because of the higher initial number of Pt active site, the amount of the active Pt sites, which are responsible for the ethane dehydrogenation, remains high and hence maintaining the high catalyst stability.

Figures 7.10 and 11 depicts that the ethane and benzene conversions increased with increasing the Pt loading in the Pt containing ZSM-5 bifunctional catalyst. 0.01PtH-ZSM-5 catalyst shows relatively low ethane and benzene conversions. This low catalyst activity could be due to the limited number of Pt active species in catalyst of low Pt loading, leading to the low ethane conversion, hence affecting the transformation of benzene with ethene into EB. Figure 7.11 (zoom in) shows that the benzene conversions, yielded by 0.01 and 0.025PtH-ZSM-5 catalysts, were very low at contact time lower than 0.02 h, suggesting that the transformations of benzene were relatively slow at low contact time. Hence, it is proposed that the extremely low ethane conversion on both catalysts, at low catalyst loadings, has hindered the alkylation of benzene with ethene. The ethane feed would be converted to greater extent over catalyst

of higher Pt loading, leading to higher ethene concentration in the gaseous mixture and hence, more benzene could be transformed (Figs. 7.10 and 7.11). The ethane and benzene conversions, yielded over 0.5 and 1 wt.% of Pt, coincide within the range of the examined contact time (Figs. 7.10 and 7.11). This observation has supported further the results presented in Figures 7.8 and 7.9 which showed the ethane and benzene conversions coincide at 0.06 h of contact time.

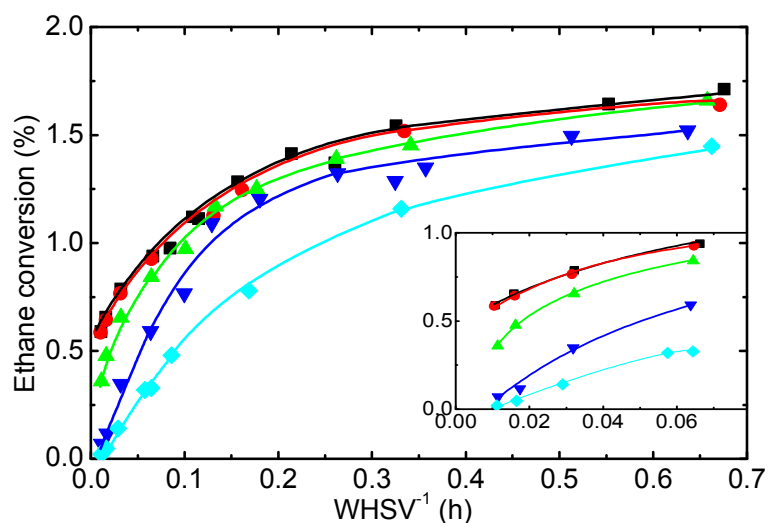

Figure 7.10. Effect of contact time on ethane conversion over (■) 1, (●) 0.5, (▲) 0.1, (▼) 0.025, and (◆) 0.01PtHZSM-5 at 370°C.

Table 7.2 shows that the Pt dispersions in the catalysts with 1 and 0.5 wt.% of Pt were 10 and 19%, respectively. It should be noted that the Pt dispersion is the percentage of the number of active Pt atoms to the total number of Pt atoms incorporated. Hence, similar number of active Pt atoms was found in 0.5 and 1PtH-ZSM-5 catalysts (Table 7.2). This suggests that the similar catalyst stability and activity, observed with both catalysts, could be due to the similarity in the number of active Pt atoms.

Benzene is converted mainly *via* benzene alkylation with ethene into EB on the acid sites and, in this case, the conversion is affected mainly by ethene concentration, as the ZSM-5 of same catalyst acidity was used. Kubicka *et al.* (2006) suggested that the total acid sites concentration of the acidic catalyst remains unchanged with the

incorporation of metal species. However, Smirnov *et al.* (2000) showed that the incorporation of 0.3 wt.% Pt modified the total acid sites concentration of H-ZSM-5 (100) from 429 to 354 μmolg^{-1} . The Pt dispersion of 0.1PtH-ZSM-5 catalyst was 90% which is in agreement with the observation by various authors that the higher Pt dispersion were observed on catalysts with low Pt loadings (Anderson, 1975, M'Kombe *et al.*, 1997 and Shpiro *et al.*, 1991).

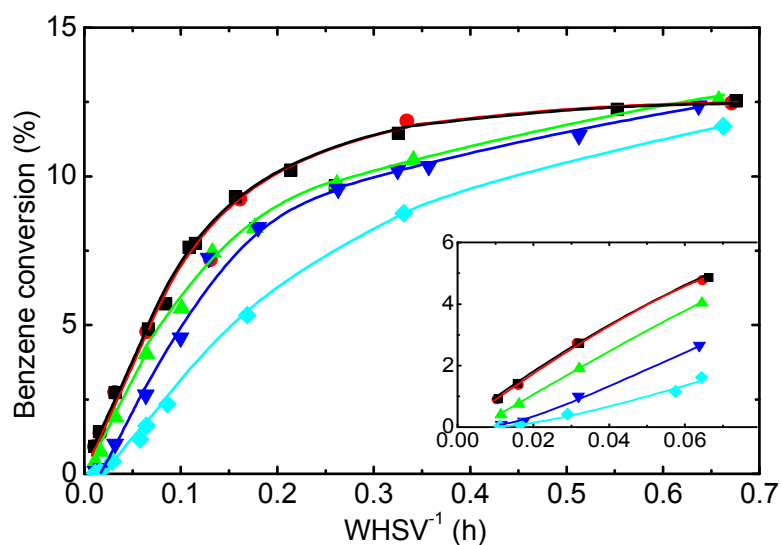

Figure 7.11. Effect of contact time on benzene conversion over (■) 1, (●) 0.5, (▲) 0.1, (▼) 0.025, and (◆) 0.01PtHZSM-5 at 370°C.

At 0.02 h of contact time, 0.01PtH-ZSM-5 catalyst yielded 0.05% of ethane conversion and the ethane conversion improved 2.5 times to 0.12% when the Pt loading increased 2.5 times to 0.025 wt.%. The ethane conversion continues to improve in the same magnitude as the rise in Pt loading, i.e. the ethane conversion increased 4 times to 0.48% over 0.1PtH-ZSM-5 catalyst (Fig. 7.12). Then, the change in ethane conversion becomes less significant over the catalyst of Pt loading higher than 0.1 wt.%. The 0.5PtH-ZSM-5 catalyst encourages slight rise in ethane conversion, i.e. from 0.48 to 0.64%, and the conversion remains constant when double amount of Pt was loaded. This observation suggests that the incorporation of Pt species up to 0.1 wt.% is very efficient as it contributes to the improvement of ethane conversion. The further rise in Pt loading

does not improve the conversion proportionally and hence becomes less economic attractive.

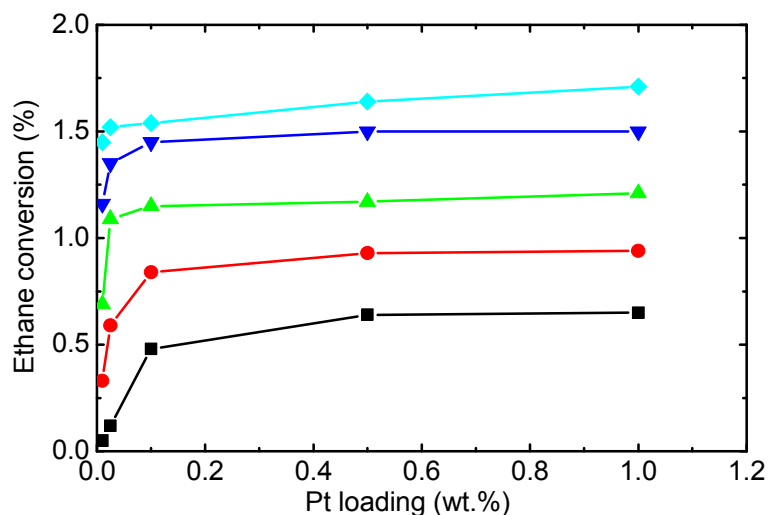

Figure 7.12. Effect of Pt loadings of PtH-ZSM-5 catalyst on ethane conversions at (■) 0.02 h, (●) 0.06 h, (▲) 0.13 h, (▼) 0.33 h, and (◆) 0.66 h of contact time at 370°C.

On the other hand, the ethane conversion does not rise proportionally with the increase in Pt loading at high contact time. At 0.33 h of contact time, the ethane conversion increases from 1.15 to 1.35% when the Pt loading of the catalyst rise from 0.01 to 0.025 wt.%. Further increase of catalyst Pt loading to 0.1 wt.% has risen the ethane conversion to 1.45% and the catalysts of 0.5 and 1 wt.% of Pt yielded 1.5% of ethane conversion at 0.33 h of contact time. At low contact time, the ethane conversion reflects directly the amount of ethane being converted *via* ethane dehydrogenation into ethene and hydrogen, as the primary reaction is dominating. At high contact time, the rate of ethane conversion could be affected also by the secondary, tertiary and reverse reactions, as these reactions are favourable at high contact time.

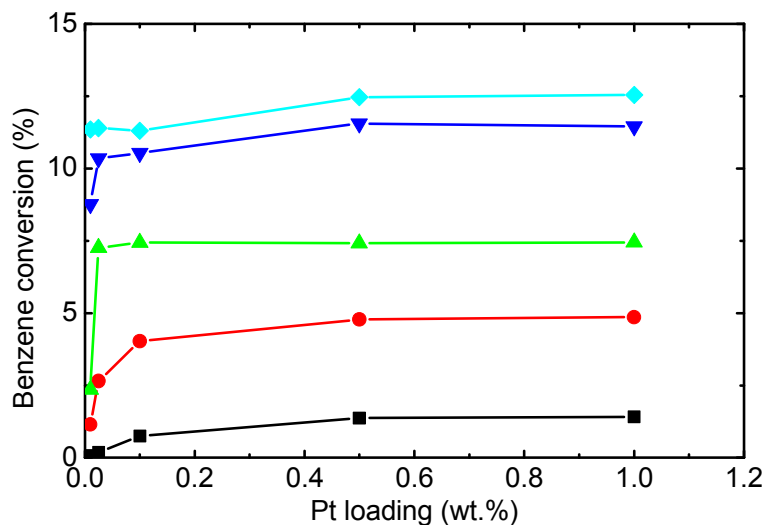

Figure 7.13. Effect of Pt loadings of PtH-ZSM-5 catalyst on benzene conversions at (■) 0.02, (●) 0.06, (▲) 0.13, (▼) 0.33, and (◆) 0.66 h of contact time at 370°C.

Figure 7.13 indicates clearly that the benzene conversions were improved significantly by catalysts with 0.01, 0.025 and 0.1 wt.% of Pt at contact time lower than 0.33 h. Further increase in the Pt loadings of the catalysts to 0.5 and 1 wt.% have led to slight increase in the benzene conversion. The 0.1PtH-ZSM-5 catalyst improves the ethane and benzene conversions (Figs. 7.12 and 7.13) and the effect of Pt loadings on the catalyst activity becomes less pronounced over catalysts with 0.5 and 1 wt.% of Pt.

Figure 7.14a shows that the selectivity of hydrogen in all products is about 50 mol.% for all catalysts with Pt loadings in the range between 0.01 and 1 wt.%. This suggests that hydrogen is produced in stoichiometric amounts by all catalysts as the overall benzene alkylation with ethane forms equimolar amount of EB and hydrogen (Eq. 5.3). Figures 7.14b and 7.14c suggest that the effect of Pt loading on the ethene and EB selectivities could be separated into low ($\leq 1\%$) and high ($\geq 1\%$) ethane conversion regions. At ethane conversion lower than 1%, the selectivities of ethene in all products increase with increasing Pt loading while similar ethene and EB selectivities in all products were observed with all catalysts at ethane conversion higher than 1%. The catalysts with 0.5 and 1 wt.% of Pt yielded identical ethene and EB selectivities regardless the ethane conversion.

At low ethane conversions, the ethene and EB selectivities in all products increased and decreased, respectively, with increasing Pt loadings (Fig. 7.14b and 7.14c). This suggests that the ethane dehydrogenation is improved by increasing the Pt loadings, i.e. more ethene is produced at higher Pt loadings catalysts. Then at a specific level of Pt loading, the amount of the incorporated Pt will have less effect on the dehydrogenation of ethane, as evidenced for 0.5 and 1 wt.%PtH-ZSM-5 catalysts. The reason for this is the different Pt dispersion on these two catalysts that lead to similar numbers of Pt active sites (Table 7.2).

It has been noted that the reactions which dominate at low contact time are ethane dehydrogenation into ethene and hydrogen and benzene alkylation with ethene into EB. The 0.01PtH-ZSM-5 catalyst yielded relatively small amount of ethene and the produced ethene reacts with benzene into EB once it is formed. Hence, the relatively low ethene and high EB selectivity were observed at the catalyst of 0.01 wt.% of Pt. On the other hand, 0.5PtH-ZSM-5 catalyst yielded much higher ethene concentration due to more Pt active species (Table 7.2).

The similar ethene and EB selectivities were observed over 0.025, 0.1, 0.5 and 1PtH-ZSM-5 catalysts at ethane conversion higher than 1%. This could be due to the fact that the transformations of both products are limited by the thermodynamic equilibrium conversions of ethane dehydrogenation and benzene alkylation with ethane at high contact time. The reverse reactions become more favourable at high contact time and when the thermodynamic equilibrium is reached, the selectivities are affected by the temperature but not by the catalyst composition. Hence, identical ethene and EB selectivities were observed at high ethane conversions where the reaction was close to thermodynamic equilibrium.

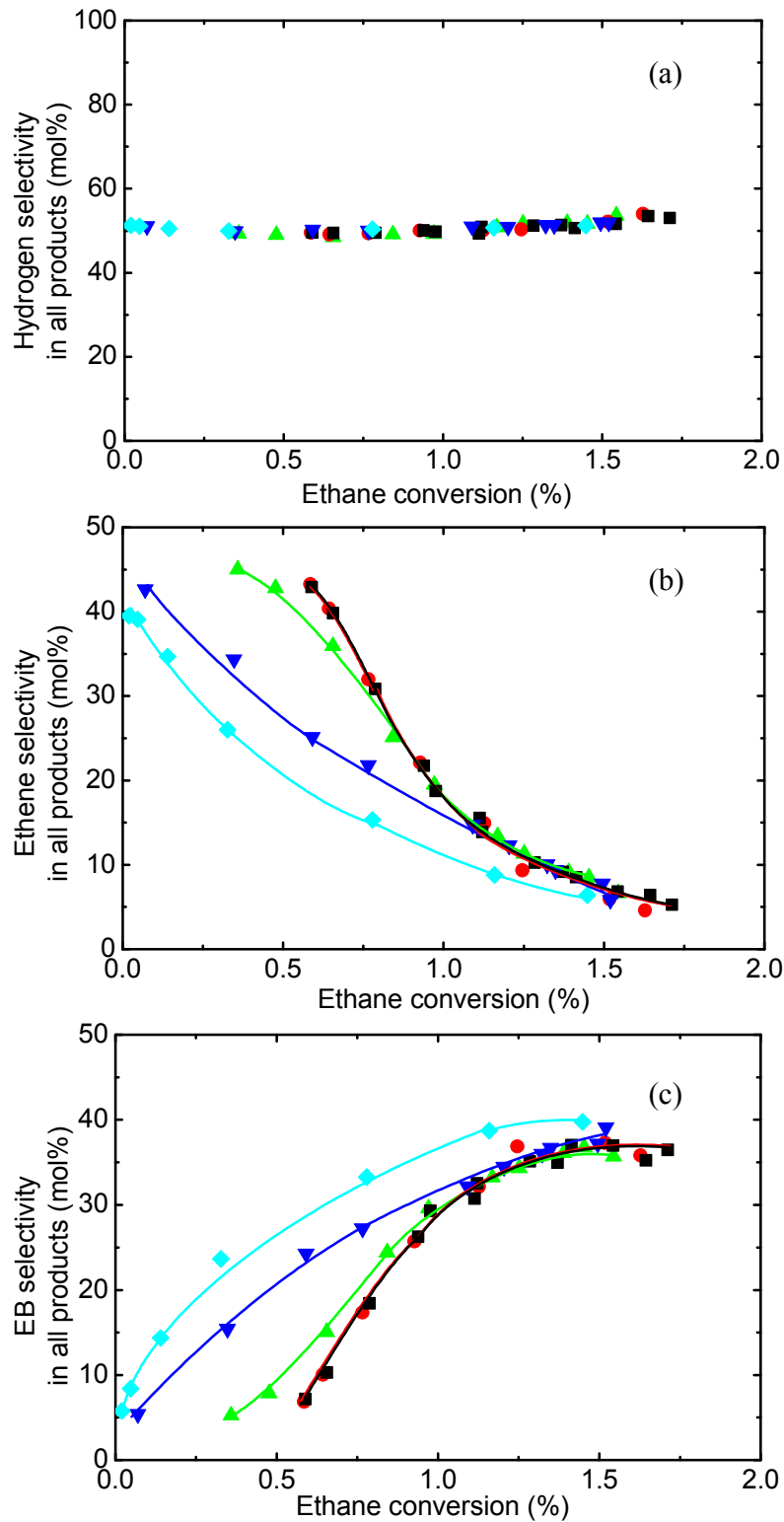

Figure 7.14. Effect of ethane conversion on (a) H₂, (b) ethene, and (c) EB selectivities in all products over (■) 1, (●) 0.5, (▲) 0.1, (▼) 0.025, and (◆) 0.01PtHZSM-5.

Table 7.3 shows the selectivities to all products observed over five PtH-ZSM-5 catalysts at 0.33 h of contact time. These results reveal that the selectivities of side products, such as methane, propane, toluene, TEBs, etc., increase with increasing Pt loadings. The high Pt loading catalysts favour the ethane dehydrogenation and produce large amount of ethene which would lead to the production of various side products.

Table 7.3. Selectivities to all products of benzene alkylation with ethane over PtH-ZSM-5 catalyst at 370°C, $\tau = 0.33$ h, TOS = 20-24 h.

Pt loading (wt.%)	0.01	0.025	0.1	0.5	1
Benzene conversion (%)	8.77	10.22	10.54	11.86	11.47
Ethane conversion (%)	1.16	1.29	1.45	1.52	1.54
Selectivities (mol.%)					
Hydrogen	50.69	50.76	51.65	52.15	51.62
Methane	0.00	0.02	0.00	0.25	0.34
Ethene	8.80	8.16	8.48	5.94	6.83
Propane	0.11	0.31	0.71	1.48	1.35
Propene	0.12	0.08	0.05	0.05	0.05
Butanes	0.07	0.04	0.05	0.11	0.10
Butenes	0.00	0.00	0.00	0.00	0.00
Toluene	0.10	0.14	0.23	0.41	0.39
Ethylbenzene	38.72	38.77	36.78	37.29	36.95
Xylenes	0.00	0.00	0.00	0.05	0.03
Propylbenzene	0.47	0.72	1.04	0.88	0.97
Ethyltoluene	0.07	0.08	0.11	0.17	0.17
Diethylbenzenes	0.75	0.83	0.82	0.85	0.84
Triethylbenzenes	0.02	0.06	0.08	0.28	0.29
Others	0.08	0.03	0.00	0.09	0.07

Figure 7.15a shows that the selectivity of EB in aromatic products increased with decreasing Pt loadings. 0.01PtH-ZSM-5 catalyst produced 98 mol.% of EB selectivity at 5 % of benzene conversion and the EB selectivity dropped to 96.5 mol.%, at the same benzene conversion, over catalyst of 0.025 wt.% Pt. The EB selectivity dropped further 1 mol.% to 95.5 mol.% when the Pt loading of the catalyst was 0.1 wt.% and 94 mol.% of EB selectivity was observed over 0.5 and 1PtH-ZSM-5 catalysts at benzene conversion of 5%.

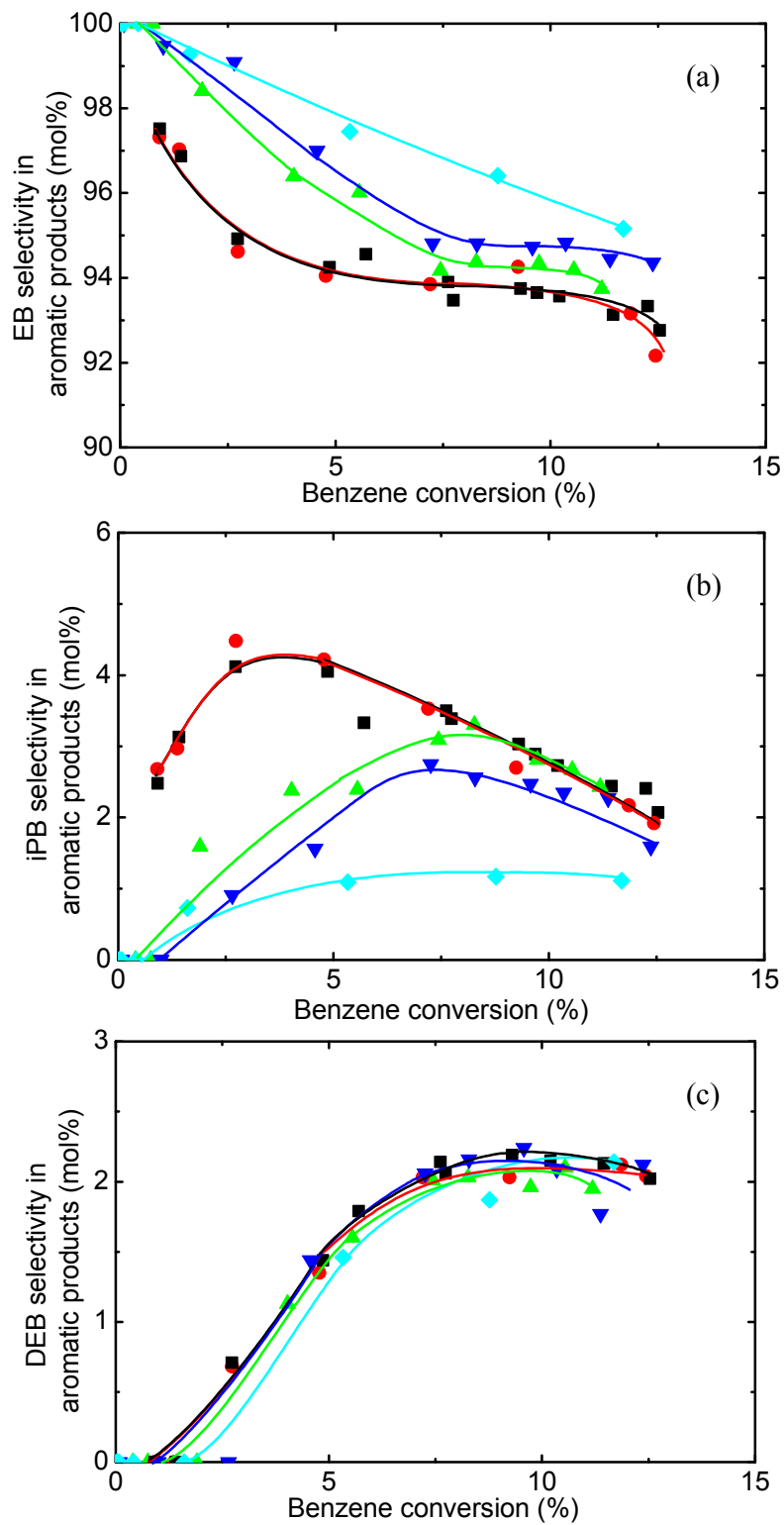

Figure 7.15. Effect of benzene conversion on (a) EB, (b) iPB, and (c) DEB selectivities in aromatic products over (■) 1, (●) 0.5, (▲) 0.1, (▼) 0.025, and (◇) 0.01PtHZSM-5.

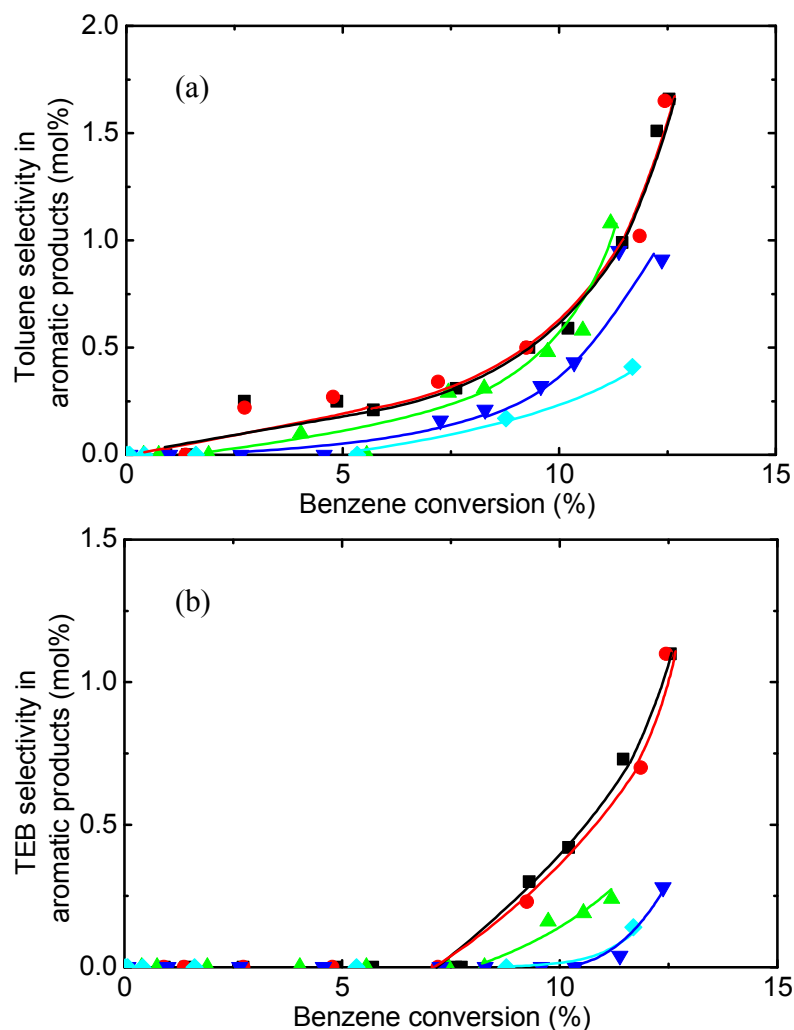

Figure 7.16. Effect of benzene conversion on (a) toluene and (b) TEB selectivities in aromatic products over (■) 1, (●) 0.5, (▲) 0.1, (▼) 0.025, and (◆) 0.01PtHZSM-5.

The drop of EB selectivity over 0.5 and 1PtH-ZSM-5 catalyst at benzene conversion lower than 5% could be mainly due to the formation of secondary products, i.e. DEB and iPB. This is supported by Figures 7.15b and 7.15c. Both graphs depict that the DEB and iPB selectivities in aromatic products, over 0.5 and 1PtH-ZSM-5 catalysts, increased significantly at 5% of benzene conversion. The EB selectivities of 0.5 and 1PtH-ZSM-5 catalysts maintained at around 94 mol.% within 5 and 10% of benzene conversion before the drop at 10% of benzene conversion. The drop of EB selectivity, over 0.5 and 1PtH-ZSM-5 catalysts, at high benzene conversion could be due to the

formation of tertiary products, such as TEB and toluene, which are favourable at high conversion (Fig. 7.16).

The EB selectivity in aromatic products was 100 mol.% at 1 % of benzene conversion for 0.025 and 0.1PtH-ZSM-5 catalysts, suggesting that EB is the only aromatic product formed at such low conversion. Then, the EB selectivity decreased dramatically, while an increase in iPB and DEB selectivities was observed (Fig. 7.15). These data support further the suggestion that the drop in EB selectivity at relatively low benzene conversion could be due to the formation of secondary products.

The EB selectivity maintained high at high benzene conversion over catalysts of 0.025 and 0.1 wt.% of Pt could be due to the less favourable formation of tertiary products over these catalysts in comparison with high loading catalysts (Fig. 7.16). The shift of the maximum of iPB selectivity to higher benzene conversion with catalysts of lower Pt loading was observed in Figure 7.15b. The high Pt loading catalysts favour the transformation of ethane, as evidenced in Figure 7.11, and produce large amounts of ethene. Ethene could be alkylated by benzene forming EB as well as transformed into various light alkenes *via* oligomerisation and cracking reactions. The subsequent involvement of these light alkenes in benzene alkylation would form various alkylbenzenes. As a result, the formation of iPB could be more favourable over high Pt loading catalysts compared to low Pt loading catalysts. The relatively low iPB selectivity over 0.01PtH-ZSM-5 catalyst does not experience a maximum suggesting that the formation of iPB is not favourable over 0.01PtH-ZSM-5 catalyst.

7.3.2. The effect of Pt loading on product distribution

The previous section showed the effects of Pt loadings on catalyst performance in terms of activity, stability and selectivity. The catalyst stability is improved by Pt loading of the bifunctional catalyst. The ethane conversion dropped from 0.45 to 0.32 % during 20 h on stream, over 0.01PtH-ZSM-5. On the other hand, stable catalyst performances were observed on catalysts of 0.025, 0.1, 0.5 and 1 wt.% of Pt. It was suggested that the low catalyst stability over 0.01PtH-ZSM-5 catalyst could be due to

the extremely small amount of active metal sites available for the ethane dehydrogenation into ethene and H₂, i.e. the primary step of benzene alkylation with ethane into EB. The effect of Pt loading on catalyst activity becomes less pronounced on catalysts with the Pt loading higher than 0.1 wt.%. Additionally, the catalyst performances of 0.5 and 1PtH-ZSM-5 catalysts coincide as similar number of active Pt atom was found in both catalysts (Table 7.2). Both catalysts were relatively active and yielded larger amount of side products, reducing the EB selectivity.

The change of the Pt loading of the bifunctional catalyst could affect also the rates of reaction steps, leading to the different product distributions. Hence, detailed analysis is carried out to investigate the effect of Pt loading on the product distribution. Figure 7.17a shows that the H₂ concentration increased with increasing Pt loading at any point of the catalyst bed. The H₂ concentration increases with increasing contact time before achieving the equilibrium conversion, and the rise in H₂ concentration becomes less pronounced at high contact time.

The shift of the maximum ethene concentration to higher contact time with catalysts of lower Pt loading was observed in Figure 7.17b. The ethene concentration yielded from 0.5 and 1PtH-ZSM-5 catalysts, increased from 0.45 to 0.47 mol.% at 0.015 h of contact time then dropped dramatically and reached 0.23 mol.% at 0.16 h of contact time. The maximum ethene concentration for 0.1PtH-ZSM-5 catalyst was achieved at 0.03 h of contact time, and 0.025 and 0.01PtH-ZSM-5 catalysts required higher contact time ($\tau = 0.1$ h) to reach the maximum ethene concentration. The shift suggests that the consecutive reaction, alkylation of benzene with ethene which consumes ethene, proceeds at higher rate on catalysts of higher Pt loadings. At low contact time, the system is dominated by ethane dehydrogenation into ethene and H₂ and benzene alkylation with ethene into EB. The initial rise in ethene concentration at low contact time is due to the formation of ethene by the primary reaction, ethane dehydrogenation reaction. The ethene concentration starts to drop when the rate of alkylation of benzene with ethene into EB is higher than the rate of primary reaction.

For catalysts of 0.5 and 1 wt.% of Pt, the ethene concentration rise dramatically then started to decrease at 0.015 h of contact time suggesting the rate of benzene alkylation with ethene becomes higher than the rate of ethane dehydrogenation at contact time higher than 0.015 h. The ethene concentration continued to rise for catalyst of 0.1 wt.% of Pt at the same contact time indicating that the ethane dehydrogenation is dominating at 0.015 h of contact time. The rate of benzene alkylation with ethene into EB became pronounced at contact time higher than 0.03 h, for 0.1PtH-ZSM-5 catalyst, which evidenced from the drop and the rise of ethene and EB concentrations, respectively (Figs. 7.17b and 7.17c). For 0.025 and 0.01PtH-ZSM-5 catalysts, the ethene concentration increased with increasing contact time and started to decrease at 0.1 h of contact time. This suggests that the rate of ethane dehydrogenation into ethene and hydrogen is relatively low over both catalysts, which have the lowest Pt loadings. In summary, the transformation of ethane into ethene is more favourable on the catalysts of high Pt loadings, due to the higher concentration of active metal species. The high concentration of ethene has enhanced the formation of EB *via* higher rate of benzene alkylation with ethene. Figures 7.18a and 7.18b show that the propane concentration increased with increasing Pt loadings, while the propene concentration increased with decreasing Pt loadings. The propene could be formed from the oligomerisation and cracking reactions of ethene and the propane could be the product of hydrogenation of propene.

The low concentrations of propene on high Pt loading catalysts suggest that propene is consumed by consecutively reactions which are favourable at high Pt loadings and contact time. This is evidenced from the high concentrations of propane and iPB over 0.5 and 1PtH-ZSM-5 catalysts (Figs. 7.18a and 7.19a). On the other hand, the low propane and iPB concentrations over 0.01PtH-ZSM-5 catalyst suggest that formation of iPB and propane is disfavoured and hence the further transformation of propene is less pronounced, leading to higher propene concentration (Fig. 7.18b).

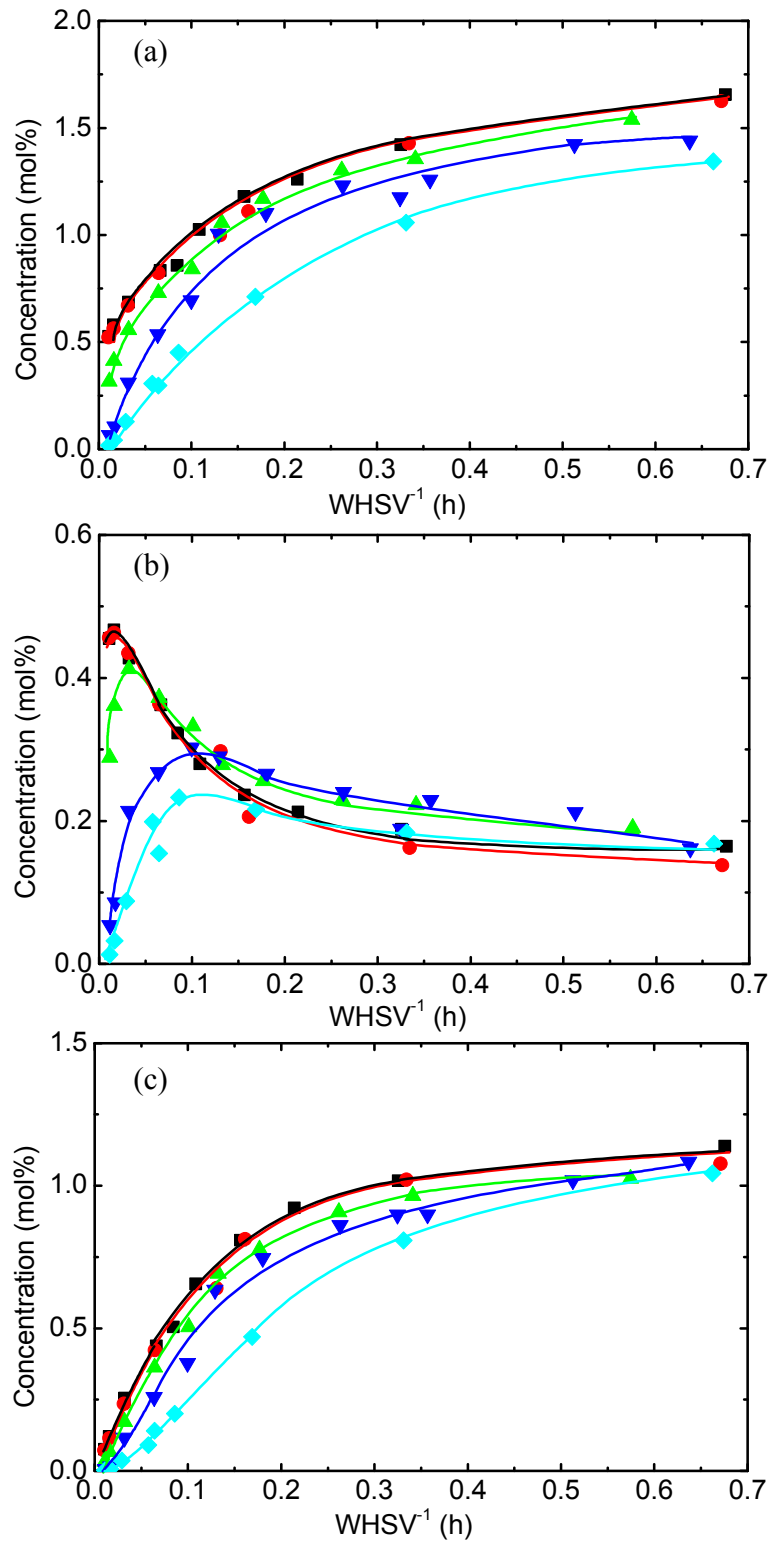

Figure 7.17. Effect of contact time on (a) H_2 , (b) ethene, and (c) EB concentrations over (■) 1, (●) 0.5, (▲) 0.1, (▼) 0.025, and (◆) 0.01PtHZSM-5.

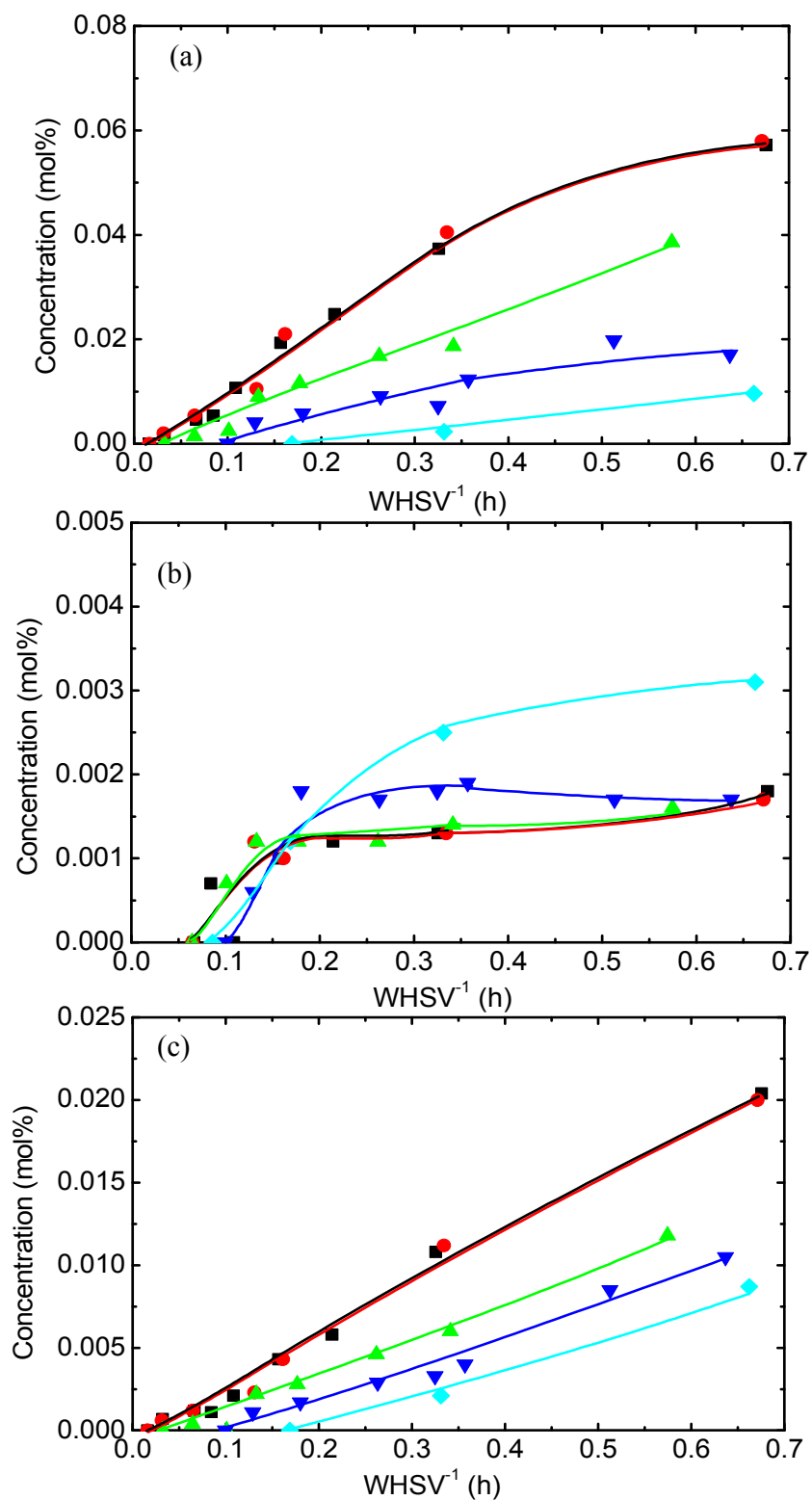

Figure 7.18. Effect of contact time on (a) propane, (b) propene, and (c) toluene concentrations over (■) 1, (●) 0.5, (▲) 0.1, (▼) 0.025, and (◆) 0.01PtHZSM-5.

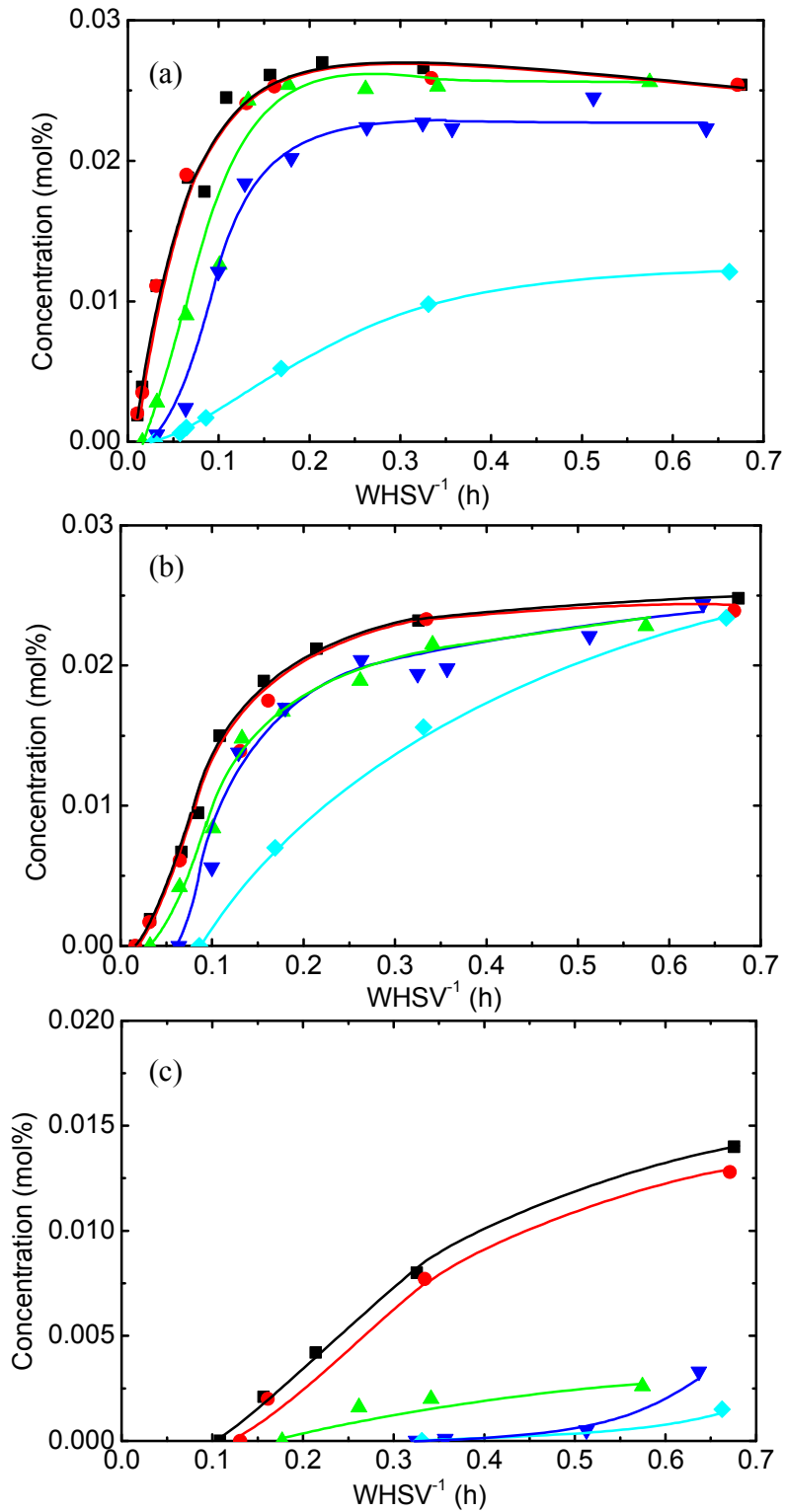

Figure 7.19. Effect of contact time on (a) PB, (b) DEB, and (c) TEB concentrations over (■) 1, (●) 0.5, (▲) 0.1, (▼) 0.025, and (◆) 0.01PtHZSM-5.

Figures 7.18 and 7.19 depict that the formation of side products, such as toluene, DEBs and TEBs, are more favourable at high Pt loading. It was proposed that these side products are formed from such transformations of EB as hydrogenolysis of EB into toluene and methane and polyalkylation of EB into DEBs and TEBs. In contrast, the low EB concentration over 0.01PtH-ZSM-5 catalyst disfavors the formation of these side products.

It is shown that Pt loading has different effects on the rates of the different reaction steps, and this leads to the different product distributions. The highest EB selectivity is achieved by the catalyst with 0.01 wt.% of Pt. However, the lower catalyst stability and activity indicate that this catalyst might not be the optimum catalyst even though the EB selectivity is as high as 95 mol.%. The catalyst performances and product distribution observed over 0.5 and 1Pt-HZSM-5 catalysts coincide, as the similar amount of active Pt atoms was found in both catalysts. Taking into consideration the catalyst activity and selectivity, it is proposed that 0.1PtH-ZSM-5 catalyst is the promising catalyst for benzene alkylation with ethane into EB and H₂. This catalyst demonstrates very stable performance and the EB selectivity of 94 mol.% is achieved at benzene conversion of 12.5%, which is very close to the maximum equilibrium conversion of benzene into EB at this temperature (13.6%). Additionally, 0.1PtH-ZSM-5 catalyst yielded relatively high ethene and EB concentrations, low side product concentrations were observed. This suggests that further transformations of ethene and EB into other light alkanes and alkenes and alkylbenzenes were suppressed.

Chapter 8

Conclusions and Future Work

8.1. Conclusions

In this project the reaction of benzene alkylation with ethane into EB was studied over a series of PtH-ZSM-5 bifunctional catalysts with different Pt loadings and the experiments were carried out at 290, 330, 370, 410, 450, and 490°C. The thermodynamic equilibrium conversions analysis was carried out prior to the experimental work to determine the reaction temperature range, i.e. 290-490°C. The equilibrium conversion of ethane dehydrogenation into ethene and hydrogen increases exponentially with increasing reaction temperatures. On the other hand, the benzene alkylation with ethene into EB is an exothermic reaction which is disfavoured at high temperature. This suggests that the reaction should be carried out at low temperature which yields low ethene concentration, and hence suppresses the coke formation, leading to high catalyst stability. Additionally, the low temperature would favour the transformation of benzene with ethene into EB. This thermodynamic equilibrium analysis has been confirmed by the catalytic experiments.

Detailed kinetic study of the reaction was performed in the temperature range of 290-490°C, during which the stability, activity and EB selectivity was investigated at all 6 temperatures. Preliminary catalytic experiments revealed that the benzene alkylation with ethane at 370°C achieved steady state after 1 hour on stream. After this time, the ethane and benzene conversions as well as the concentration of the main products (ethene, hydrogen and EB) remained unchanged up to nearly 50 h on stream. High catalyst activity was observed at 450 and 490°C, at which 17 and 20% of benzene conversions were yielded at 450 and 490°C, respectively. The high ethane conversions at 450 and 490°C, i.e. 4 and 7%, respectively, are due to the exponential rise of equilibrium ethane dehydrogenation conversion at high temperature. However, lower catalyst stability was observed at both temperatures. At 490°C, the benzene and ethane conversions drop from 16 to 13% and from 6.2 to 5.5%, respectively, over nearly 45 h on stream (at 0.14 h of contact time which is corresponded to 0.13 s of residence time). The drop of benzene and ethane conversions at 450°C was less significant (same WHSV⁻¹), namely the benzene conversion dropped from 15.2 to 14.5% and the drop in ethane conversion is less than 0.2%, over nearly 48 h on stream. The decrease in the catalyst

stability at higher reaction temperature is likely to be due to the enhanced formation, at this temperature, of heavy aromatics, such as C₁₀-C₁₂ alkylbenzenes and naphthalenic compounds, leading to higher coking rate. In addition to the low catalyst stability, the enhanced formation of heavy aromatics at high temperature has led to the low EB selectivity. The EB selectivity was 60 mol.% at 20% of benzene conversion, at 490°C, while at 450°C, 72 mol.% of EB selectivity was achieved at 17.5% of benzene conversion. Extremely stable catalyst performance in benzene alkylation with ethane into EB was achieved at lower temperatures, i.e. 290, 330, 370 and 410°C. Indeed, no changes were observed at these temperatures in benzene and ethane conversions during nearly 50 h on stream. However, low catalyst activity was observed at 290°C, at which the maximum ethane and benzene conversions were 0.5 and 2.5%, respectively. Traces of iPB and DEBs were observed at 290°C, and practically no tertiary products, such as TEBs, were detected at this temperature. The differences in product distributions at different temperatures showed that the temperature has different effects on the rates of the different reaction steps.

Taking into consideration the catalyst activity, stability and selectivity, it is concluded that 370°C is the optimum temperature among the temperatures studied in this work, i.e. 290, 330, 370, 410, 450, and 490°C. At this temperature, very stable catalyst operation is obtained and the EB selectivity above 90 mol.% is achieved at benzene conversion of 12.5%, which is very close to the maximum equilibrium conversion of benzene with ethane into EB at 370°C, 13.6%.

The reaction pathways of benzene alkylation with ethane into EB were established in the temperature range of 290-490°C. Similar reaction pathways operate in this temperature range. It is shown that EB formation proceeds *via* two consecutive reaction steps: (i) ethane dehydrogenation into ethene and hydrogen on Pt sites, and (ii) benzene alkylation with ethene into EB over BAS. The detailed reaction scheme of benzene alkylation with ethane into EB at 370°C was proposed, and it is shown in Figure 6.7. The ethene, which formed in the primary reaction step, could undergo oligomerisation, cracking and aromatisation reactions producing various side products. Other side

reactions include the hydrogenolysis of ethane into methane, alkylation of benzene with propene producing PBs; and the isomerisation, hydrogenolysis, dialkylation, transalkylation and disproportionation of EB forming xylene isomers, toluene and methane, benzene and ethene, toluene, benzene and DEB, respectively. The tertiary reaction steps are the DEB alkylation with ethene and hydrogenolysis with H₂ which produce TEB and ethyltoluene and methane, respectively.

The second stage of the project focused on the optimisation of the catalyst compositions, by determining the optimum balance between the acid and Pt sites of the bifunctional catalyst, to improve the catalyst performances at the selected optimum temperature. The metal function optimisation was carried out using PtH-ZSM-5 catalysts with 0.01, 0.025, 0.1, 0.5, and 1 wt.% of Pt. The results showed that the incorporation of Pt into H-ZSM-5 catalyst improved significantly the conversion of ethane by providing an additional Pt catalysed route, ethane dehydrogenation into ethene and hydrogen. Similar catalyst performances and product distributions were observed with 0.5 and 1Pt-HZSM-5 catalysts as both catalysts contain very similar numbers of active Pt species. The 0.01PtH-ZSM-5 catalyst yielded low catalyst stability and activity due to the extremely small amount of active Pt species. The 0.1PtH-ZSM-5 catalyst was the most promising catalyst among the catalysts examined. Compared to 1PtH-ZSM-5, 0.1PtH-ZSM-5 catalyst contains 10 times less Pt and improves the EB selectivity from 90 to 94 mol.% at 12.5% of benzene conversion. The product distribution obtained with 0.1PtH-ZSM-5 catalyst (high EB selectivity with low side product selectivities) shows that the optimum balance of Pt and acid sites of the bifunctional catalyst improves EB selectivity by suppressing the side reactions noted above.

8.2. Future work

This PhD thesis provides detailed analysis of benzene alkylation with ethane into EB over Pt containing ZSM-5 bifunctional catalyst. The optimum reaction temperature and the promising PtH-ZSM-5 catalyst were established. The catalyst has shown excellent catalyst performance at 370°C which catalyst was stable up to nearly 48 hours and above 90 mol.% of EB selectivity was obtained at 12.5% of benzene conversion.

Hence, the further improvement and development of the reaction could be focused on improving the catalyst activity.

The equilibrium conversion of benzene alkylation with ethane into EB and hydrogen could be improved by removing a product, and hence, shifting the equilibrium forward. The benzene alkylation with ethane into EB and hydrogen could operate in the presence of hydrogen scavengers, such as intermetallic compounds like Zr_2Fe (Smirnov, *et al.*, 2000). The hydrogen scavengers could remove the hydrogen, which is a by-product of benzene alkylation with ethane, shifting the equilibrium forward, i.e. enhancing benzene and ethane conversion into EB and hydrogen. From the reaction stoichiometry, no influence of the pressure is expected on the equilibrium conversion of benzene alkylation with ethane into EB and hydrogen. Singer, *et al.* (2007) improved toluene conversion of toluene alkylation with ethane into ethyltoluene and hydrogen from 6 to 28% by increasing the total pressure to 50 bars. Hence, higher conversions and yields of benzene alkylation with ethane into EB and hydrogen could be achieved by operating the system at higher total pressure. Furthermore, the effect of pressure on the catalyst performances, rates of reaction steps and reaction mechanisms can be established in these series of experiments.

The thermodynamic equilibrium analysis (Chapter 4) predicted the effect of feed ratio on the equilibrium conversions. It was proposed that higher equilibrium conversion of benzene could be achieved by high ethane/benzene feed ratio. This prediction could be verified by performing experiments on benzene alkylation with ethane into EB over PtH-ZSM-5 catalyst with various ethane/benzene feed ratios. The ethane/benzene feed ratio could be monitored by varying the benzene feed vapour pressure.

A transient period was observed in the benzene alkylation with ethane into EB and hydrogen over PtH-ZSM-5 catalyst, as discussed in Chapter 5. The transient period results from a complex interplay of a great variety of factors, the effects of which are not easy to separate. Hence, the detailed analyses could be carried out in the future work to

understand fully the transient period, such as the reasons for the occurrence of the transient period and the factors affecting the length of the transient period.

The new catalytic reaction pathway developed in this work, benzene alkylation with ethane into EB and hydrogen, could be used as a reference for the development of the production of iPB, which is the primary feedstock for the synthesis of phenol. The new catalytic reaction which produces iPB could be carried out *via* benzene alkylation with propane into iPB and hydrogen over metal containing zeolite bifunctional catalysts. The reaction could operate under conditions similar to benzene alkylation with ethane into EB, possibly at lower reaction temperature as propane is more reactive than ethane.

References

- Abdul Hamid, S. B., Derouane, E. G., Meriaudeau, P., Naccache, C., 1996. Effect of reductive and oxidative atmospheres on the propane aromatisation activity and selectivity of Ga/H-ZSM-5 catalysts. *Catalysis Today* 31, 327-334.
- Agency for Toxic Substances and Disease Registry (ATSDR), 1999. Toxicological profile for ethyl benzene. Atlanta, GA: U. S. Department of health and human services, public health service.
- Anderson, J. A., Garcia, M. F., ed., 2005. Supported metals in catalysis. London: Imperial College Press.
- Anderson, J. R., 1975. Structure of metallic catalysts. London: Academic Press.
- Armaroli, T., Simon, L. J., Digne, M., Montanari, T., Bevilacqua, M., Valtchev, V., Patarin, J., Busca, G., 2006. Effects of crystal size and Si/Al ratio on the surface properties of H-ZSM-5 zeolites. *Applied Catalysis A: General* 306, 78-84.
- Arsenova-Hartel, N., Haag, W. O., Karge, H. G., 1999. Pre-stationary period in the ethylbenzene disproportionation over zeolite catalysts. *Studies in Surface Science and Catalysis* 125, 341-350.
- Banares, M. A., 1999. Supported metal oxide and other catalysts for ethane conversion: a review. *Catalysis Today* 51, 319-348.
- Bandyopadhyay, R., Singh, P. S., Shaikh, R. A., 1996. Transalkylation of cumene with toluene over zeolite beta. *Applied Catalysis A: General* 135, 249-259.
- Bevington, P. R., Robinson, D. K., 1992. Data reduction and error analysis for the physical sciences. McGraw-Hill, United State of America.
- Bhasin, M. M., McCain, J. H., Vora, B. V., Imai, T., Pujado, P. R., 2001. Dehydrogenation and oxydehydrogenation of paraffins to olefins. *Applied Catalysis A: General* 221, 397-419.
- Bigey, C., Su, B.-L., 2004. Propane as alkylating agent for alkylation of benzene in HZSM-5 and Ga-modified HZSM-5 zeolites. *Journal of Molecular Catalysis A: Chemical* 209, 179-187.
- Biscardi, J. A., Iglesia, E., 1998. Isotopic tracer studies of propane reactions on HZSM5 zeolite. *Journal of Physical Chemistry B* 102, 9284-9289.
- Bragin, O. V., Shpiro, E. S., Preobrazhensky, A. V., Isaev, S. A., Vasina, T. V., Dyusenbina, B. B., Antoshin, G. V., Minachev, K. M., 1986. The state of platinum in high-silica zeolites and its catalytic activity in ethane and propane aromatisation. *Applied Catalysis* 27, 219-231.

Brillis, A.A., Manos, G., 2003. Coke formation during catalytic cracking of C₈ aliphatic hydrocarbons over ultrastable Y zeolite. *Industrial & Engineering Chemistry Research* 42, 2292-2298.

Buckles, G. J., Hutchings, G. J., 1996. Aromatisation of propane over Ga/H-ZSM5: comments on the activation of propane. *Catalysis Today* 31, 233-246.

Caeiro, G., Carvalho, R. H., Wang, X., Lemos, M.A.N.D.A., Lemos, F., Guisnet, M., Ramoa Ribeiro, F., 2006. Activation of C₂-C₄ alkanes over acid and bifunctional zeolite catalysts. *Journal of Molecular Catalysis A: Chemical* 255, 131-158.

Canizares, P., de Lucas, A., Dorado, F., Aguirre, J., 2001. n-Butane hydroisomerization over Pd/HZSM-5 catalysts. Palladium loaded by ion exchange. *Microporous and Mesoporous Materials* 42, 245-254.

Chemical Market Associates, 2004. World light olefins analysis, volume I and II. Houston, Tx: Chemical market associates.

<http://www.ethylbenzene.org/content/1.html> (Viewed on 13/1/06)

Clark, M., 2005. Investigation of ethane conversion over a bifunctional catalyst: effects of pre-treatment and time on stream. Undergraduate research project, Department of Chemical Engineering, University of Bath.

Cortright, R. D., Watwe, R. M., Spiewak, B. E., Dumesic, J. A., 1999. Kinetics of ethane hydrogenolysis over supported platinum catalysts. *Catalysis Today* 53, 395-406.

Corma, A., Martinez-Soria, V., Schnoefeld, E., 2000. Alkylation of benzene with short-chain olefins over MCM-22 zeolite: catalytic behaviour and kinetic mechanism. *Journal of Catalysis* 192, 163-173.

Degnan, Jr T. F., Smith, C. M., Venkat, C. R., 2001. Alkylation of aromatics with ethylene and propylene: recent developments in commercial processes. *Applied Catalysis A: General* 221, 283-294.

Den Otter, G. J., Dautzenberg, F. M., 1978. Metal-support interaction in Pt/Al₂O₃ catalysts. *Journal of Catalysis* 53, 116-125.

Derouane, E. G., He, H., Hamid, S. B. D., Lambert, D., Ivanova, I., 2000. In situ MAS NMR spectroscopy study of catalytic reaction mechanisms. *Journal of Molecular Catalysis A: Chemical* 158, 5-17.

Dimitrova, R., Gunduz, G., Spassova, M., 2006. A comparative study on the structural and catalytic properties of zeolites type ZSM-5, mordenite, Beta and MCM-41. *Journal of Molecular Catalysis* 243, 17-23.

Dooley, K. M., Chang, C., Price, G. L., 1992. Effects of pretreatments on state of gallium and aromatisation activity of gallium/ZSM5 catalysts. *Applied Catalysis A: General* 84, 17-30.

- Du, Y., Wang, H., Chen, S., 2002. Study on alkylation of benzene with ethylene over β -zeolite catalyst to ethylbenzene by in site IR. *Journal of Molecular Catalysis A: Chemical* 179, 253-261.
- Dyer, A., 1988. *An introduction to zeolite molecular sieves*. Great Britain: John Wiley & Sons Ltd.
- Fogler, H. S., 2006. *Element of chemical reaction engineering*. United State of America: Prentice-Hall, Inc., 1-29.
- Folefoc, G. N., Dwyer, J., 1992. Dispersion of platinum in Pt/ZSM-5 zeolites. *Journal of Catalysis* 136, 43-49.
- Franke, M. E., Simon, U., Roessner, F., Roland, U., 2000. Influence of spilt-over hydrogen on the electrical properties of H-ZSM5. *Applied Catalysis A: General* 202, 179-182.
- Frennet, A., Hubert, C., 2000. Transient kinetics in heterogeneous catalysis by metals. *Journal of Molecular Catalysis A: Chemical* 163, 163-188.
- Guczi, L., Bazin, D., 1999. Structure and selectivity of metal catalysts: revisiting bimetallic zeolite systems. *Applied Catalysis A: General* 188, 163-174.
- Guczi, L., Gudkov, B. S., 1978. Effect of dispersity on some catalytic reactions on Pt/SiO₂. *Reaction Kinetics and Catalysis Letters* 9, 343-347.
- Guisnet, M., Gnep, N. S., 1992. Aromatisation of short chain alkanes on zeolite catalysts. *Applied Catalysis A: General* 89, 1-30.
- Guisnet, M., Gnep, N. S., Aittaleb, D., Doyemet, Y. J., 1992. Conversion of light alkanes into aromatic hydrocarbons VI. Aromatisation of C₂-C₄ alkanes on H-ZSM-5 – reaction mechanisms. *Applied Catalysis A: General* 87, 255-270.
- Haag, W. O., Dessau, R. M., 1984. Duality of mechanism for acid-catalysed paraffine cracking. In: *Proceedings of the Eighth International Congress on Catalysis*, vol. 2. Dechema, Frankfurt-am-Main, 305-316.
- Han, K. S., Han, O. H., Babu, P. K., 2005. Metal particle size effects and metal-support interaction in electrochemically treated Pt/C catalysts investigated by ¹³C NMR. *Journal of The Electrochemical Society* 152, J131-J135.
- Hancock, E. G., ed., 1975. *Benzene and its industrial derivatives*. London: Ernest Benn Limited.
- Hoeldrich, W. F., 2000. Environmentally benign manufacturing of fine and intermediate chemicals. *Catalysis Today* 62, 115-130.
- Ivanova, I. I., Brunel, D., Nagy, J. B., Derouane, E. G., 1995. An in site ¹³C MAS NMR study of benzene isopropylation over H-ZSM11: cumene formation and side reactions. *Journal of Molecular Catalysis* 95, 243-258.

- Ivanova, I. I., Blom, N., Derouane, E. G., 1996. ^{13}C MAS NMR mechanistic study of benzene alkylation with propane over Ga-modified H-ZSM-5 catalyst. *Journal of Molecular Catalysis A: Chemical* 109, 157-168.
- Ivanova, I. I., Nesterenko, N. S., Fernandez, C., 2006. In situ MAS NMR studies of alkylaromatics transformations over acidic zeolites. *Catalysis Today* 113, 115-125.
- Jackson, S. D., 2006. Processes occurring during deactivation and regeneration of metal and metal oxide catalysts. *Chemical Engineering Journal* 120, 119-125.
- Jackson, S. D., Kelly, G. J., Webb, G., 1998. Supported metal catalysts; preparation, characterisation, and function Part VI. Hydrogenolysis of ethane, propane, n-butane and iso-butane over supported platinum catalysts. *Journal of Catalysis* 176, 225-234.
- Jao, R. -M., Leu, L. -J., Chang, J. -R., 1996. Effects of catalyst preparation and pre-treatment on light naphtha isomerisation over mordenite-supported Pt catalysts: Optimal reduction temperature for pure feed and for sulphur-containing feed. *Applied Catalysis A: General* 135, 301-316.
- Joshi, Y. V., Thomson, K. T., 2005. The role of gallium hydride and Brønsted acidity in light alkane dehydrogenation mechanisms using Ga-exchanged HZSM-5 catalysts: A DFT pathway analysis. *Catalysis Today* 105, 106-121.
- Kato, S., Nakagawa, K., Ikenaga, N., Suzuki, T., 2001. Alkylation of benzene with ethane over platinum-loaded zeolite catalyst. *Catalysis Letter* Vol. 33, No 2-4, 175-180.
- Kaeding, W. W., 1985. Shape-selective reactions with zeolite catalysts: V. Alkylation or disproportionation of ethylbenzene to produce p-diethylbenzene. *Journal of Catalysis* 95, 512-519.
- Krogh, A., Hagen, A., Hansen, T. W., Christensen, C. H., Schmidt, I., 2003. Re/HZSM5: a new catalyst for ethane aromatisation with improved stability. *Catalysis Communications* 4, 627-630.
- Kubicka, D., Narendra, K., Venalainen, T., Karbu, H., Kubickova, I., Osterholm, H., Murzin, D. Y., 2006. Metal-support interactions in zeolite-supported noble metals: influence of metal crystallites on the support acidity. *Journal of Physical Chemistry B* 110, 4937-4946.
- Kuhlmann, A., Roessner, F., Schwieger, W., Gravenhorst, O., Selvam, T., 2004. New bifunctional catalyst based on Pt containing layered silicate Na-illerite. *Catalysis Today* 97, 303-306.
- Kusakari, T., Tomishige, K., Fujimoto, K., 2002. Hydrogen spillover effect on cumene cracking and n-pentane hydroisomerisation over Pt/SiO₂ + H-Beta. *Applied Catalysis A: General* 224, 219-228.
- Kwak, B. S., Sachtler, W. M. H., Haag, W. O., 1994. Catalytic Conversion of propane to aromatics: effects of adding Ga and/or Pt to HZSM-5. *Journal of Catalysis* 149, 465-473.

- Lambert, C. K., Gonzalez, R. D., 1998. The importance of measuring the metal content of supported metal catalysts prepared by the sol-gel method. *Applied Catalysis A: General* 172, 233-239.
- Lukyanov, D. B., Gnep, N. S., Guisnet, M. R., 1994. Kinetic modelling of ethene and propene aromatisation over HZSM-5 and GaHZSM-5. *Industrial & Engineering Chemistry Research* 33, 223-234.
- Lukyanov, D. B., Gnep, N. S., Guisnet, M. R., 1995. Kinetic modelling of propane aromatisation reaction over HZSM-5 and GaHZSM-5'. *Industrial & Engineering Chemistry Research* 34, 516-523.
- Lukyanov, D. B., Vazhnova, T., 2008a. Highly selective and stable alkylation of benzene with ethane into ethylbenzene over bifunctional PtH-MFI catalysts. *Journal of Molecular Catalysis A: General* 279, 128-132.
- Lukyanov, D. B., Vazhnova, T., 2008b. A kinetic study of benzene alkylation with ethane into ethylbenzene over bifunctional PtH-MFI catalyst. *Journal of Catalysis* 257, 382-389.
- M'Kombe, C. M., Dry, M. E., O'Connor, C. T., 1997. Influence of preparation variables on the dispersion of platinum on zeolite KL. *Zeolites* 19, 175-179.
- MacQuarrie, D. J., 2000. Chemistry on the inside: green chemistry in mesoporous materials. *Philosophical Transactions of the Royal Society A: Mathematical, Physical and Engineering Sciences* 358, 419-430.
- Marecot, P., Bahloul, D., Barbier, J., 1989. Effect of the activation conditions on the catalytic properties of Pt/Al₂O₃ catalysts. *Reaction Kinetics and Catalysis Letters* 38, 85-90.
- Menon, P. G., Froment, G. F., 1981. Residual hydrogen in supported platinum catalysts and its influence on their catalytic properties. *Applied Catalysis* 1, 31-48.
- Meriaudeau, P., Ellestad, H. O., Dufaux, M., Naccache, C., 1982. Metal-support interaction. Catalytic properties of TiO₂-supported platinum, iridium, rhodium. *Journal of Catalysis* 75, 243-250.
- Meriaudeau, P., Naccache, C., 1990. The role of Ga₂O₃ and proton acidity on the dehydrogenating activity of Ga₂O₃-HZSM-5 catalysts: evidence of a bifunctional mechanism. *Journal of Molecular Catalysis* 59, L31-L36.
- Meyers, R. A., 2004. Handbook of petrochemical production processes, part 5: Ethylbenzene. McGraw-Hill.
- Mitsutani, A., 2002. Future possibilities of recently commercialized acid/base-catalyzed chemical processes. *Catalysis Today* 73, 57-63.
- Moreau, F., Gnep, N. S., Lacombe, S., Merlen, E., Guisnet, M., 2002. Ethylbenzene transformation on bifunctional Pt/Al₂O₃-NaHMOR catalysts. Influence of Na exchange

on their activity and selectivity in ethylbenzene isomerisation. *Applied Catalysis A: General* 230, 253-262.

Mroczek, U., Steinberg, K.-H., Roessner, F., 1991. Influence of hydrogen on the aromatisation of ethane over Pt/HZSM-5 zeolite. *Reaction Kinetics Catalysis Letters* 44, 201-207.

Netzer, D., 1999. Integrate ethylbenzene production with an olefins plant. *Hydrocarbon Processing*, 78, 77-88.

Nayssilov, G. N., 1993. Structure and catalytic transformation of lower hydrocarbons on single-crystal surfaces of transition metals. *Advances in Colloid and Interface Science* 47, 25-57.

Nguyen, L. H., Vazhnova, T., Kolaczowski, S. T., Lukyanov, D. B., 2006. Combined experimental and kinetic modelling studies of the pathways of propane and n-butane aromatisation over H-ZSM-5 catalyst. *Chemical Engineering Science* 61, 5881-5894.

Olah, G. A., Schilling, P., Staral, J. S., Halpern, Y., Olah, J. A., 1975. Electrophilic reactions at single bonds. XIV. Anhydrous fluoroantimonic acid catalysed alkylation of benzene with alkanes and alkane-alkene and alkane-alkylbenzene mixtures. *Journal of American Chemical Society* 97, 6807-6810.

Olson, D. H., Haag, W. O., 1984. Structure-selectivity relationship in xylene isomerisation and selective toluene disproportionation. *Catalytic Materials* 248, 275-307.

Perego, C., Ingallina, P., 2002. Recent advances in the industrial alkylation of aromatics: new catalysts and new processes. *Catalysis Today* 73, 3-22.

Perot, G., Guisnet, M., 1990. Advantages and disadvantages of zeolites as catalysts in organic chemistry. *Journal of Molecular Catalysis* 61, 173-196.

Quann, R. J., Green, L. A., Tabak, S. A., Krambeck, F. J., 1988. Chemistry of olefin oligomerisation over ZSM-5 catalyst. *Industrial & Engineering Chemistry Research* 27, 565-570.

Raddi de Araujo, L. R., Schmal, M., 2000. The calcination effects on Pt/HZSM5 catalysts in the aromatisation of propane. *Applied Catalysis A: General* 203, 275-284.

Ren, T., Patel, M., Blok, K., 2006. Olefins from conventional and heavy feedstocks: energy use in steam cracking and alternative processes. *Energy* 31, 425-451.

Reschetilowski, W., Mroczek, U., Steinberg, K. -H., 1991. Influence of platinum dispersion on the ethane aromatisation on Pt/H-ZSM-5 zeolite. *Applied Catalysis* 78, 257-264.

Roland, U., Salzer, R., Braunschweig, T., Roessner, F., Winkler, H., 1995. Investigations on hydrogen spillover: Part 1. – Electrical conductivity studies on titanium dioxide. *Journal of the Chemical Society Faraday Transactions* 91 (7), 1091-1095.

- Romero, M. D., de Lucas, A., Calles, J. A., Rodriguez, A., 1996. Bifunctional catalyst Ni/HZSM-5: effects of the nickel incorporation method. *Applied Catalysis A: General* 146, 425-441.
- Rylander, P. N., 1967. *Catalytic hydrogenation over platinum metal*. Academic Press, USA: New Jersey.15-16.
- Santilli, D. S., 1986. The mechanism of aromatic transalkylation in ZSM-5. *Journal of Catalysis* 99, 327-334.
- Schumacher R., Karge, H. G., 1999. Sorption kinetics study of the diethylbenzene isomers in MFI-type zeolites. *Microporous and Mesoporous Materials* 30, 307-314.
- Sealy, S., Traa, Y., 2005. Direct alkylation of toluene with ethane on bifunctional zeolite catalysts. *Applied Catalysis A: General* 294, 273-278.
- Shpiro, E. S., Joyner, R. J., Minachev, K. M., Pudney, D. A., 1991. Structural studies of platinum/ZSM-5 catalysts. *Journal of Catalysis* 127, 366-376.
- Singer, D., Rezai, S. A. S., Sealy, S., Traa, Y., 2007. Influence of pressure during the alkylation of toluene with ethane. *Industrial & Engineering Chemistry Research* 46, 395-399.
- Slinkin, A. A., 1980. Problems in the study of supported metal catalysts. *Russian Chemical Reviews* 49, 1980.
- Smirniotis, P. G., Ruchenstein, E., 1993. Comparison between zeolite β and γ -Al₂O₃ supported Pt for reforming reactions. *Journal of Catalysis* 140, 526-542.
- Smirnov, A. V., Mazin, E. V., Yuschenko, V. V., Knyazeva, E. E., Nesterenko, S. N., Ivanova, I. I., Galperin, L., Jensen, R., Bradley, S., 2000. Benzene alkylation with propane over Pt-modified MFI zeolites. *Journal of Catalysis* 194, 266-277.
- Smirnov, A. V., Mazin, E. V., Ponomoreva, O. A., Knyazeva, E. E., Nesterenko, S. N., Ivanova, I. I., 2001. Benzene alkylation with alkanes over modified MFI catalysts. Proc. 13th IZC, Montpellier. *Studies in Surface Science and Catalysis* 135, 153-160.
- Speight, J. G., Ozum, B., 1979. *Petroleum refining processes*. CRC Press, Chapter 15.
- Stakheev, A. Y., Kustov, L. M., 1999. Effects of the support on the morphology and electronic properties of supported metal clusters: modern concept and progress in 1990s. *Applied Catalysis A: General* 188, 3-35.
- Stiles, A. B., 1987. *Catalyst supports and supported catalyst: theoretical and applied concepts*. United State of America: Butterworth Publishers.
- Treesukol, P., Srisuk, K., Limtrakul, J., Truong, T. N., 2005. Nature of the metal-support interaction in bifunctional catalytic PtH-ZSM-5 zeolite. *Journal of Physical Chemical B* 109, 11940-11945.

Trombetta, M., Alejandre, A. G., Solis, J. R., Busca, G., 2000. An FT-IR study of the reactivity of hydrocarbons on the acid sites of HZSM5 zeolite. *Applied Catalysis A: General* 198, 81-93.

Tsai, T., Wang, I., 1992. Disproportion mechanism study of probing by n-propylbenzene. *Journal of Catalysis* 133, 136-145.

Ullmann's Encyclopaedia of Industrial Chemistry, 1996. Volume A5, 5th Edition, VCH, 314-362.

Ullmann's Encyclopaedia of Industrial Chemistry, 1996. Volume A28, 5th Edition, VCH, 481-496.

Van den Broek, A. C. M., van Grondelle, J., van Santen, R. A., 1997. Preparation of highly dispersed platinum particles in HZSM-5 zeolite: A study of the pre-treatment process of $[\text{Pt}(\text{NH}_3)_4]^{2+}$. *Journal of Catalysis* 167, 417-424.

Woltz, C., Jentys, A., Lercher, J. A., 2005. Improving bifunctional zeolite catalysts for alkane hydroisomerisation via gas phase sulfation. *Journal of Catalysis* 237, 337-348.

Yaws, C. L., 1992. Thermodynamic and physical property data. Gulf Publishing.

Yoon, C., Yang, M. X., Somorjai, G. A., 1998. Reaction of 1-butene and cis-2-butene on platinum surfaces: structure sensitivity of cis-2-butene isomerisation. *Journal of Catalysis* 176, 35-41.

Yoon, S., Lee, J., Park, S., 2007. Heat integration analysis for an industrial ethylbenzene plant using pinch analysis. *Applied Thermal Engineering* 27, 886-893.

Zadorsky, W. M., 1998. Catalyst impregnation [online]. Available from: http://www.ukrainebiz.com/technical/catalyst_impregnation.htm. [Accessed 9th June 2006].

Appendix 1: Thermodynamic Calculations

A1.1. Benzene alkylation with ethane

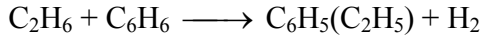

Table A1.1. Thermodynamics data at 298K, $C_p/R = a+bT+cT^2+d/T^2$ (Yaw, 1992).

Components	ΔH (J/mol)	ΔS (J/molK)	a	b	c	d
C2	-84000	229.2	1.131	0.0192	-5.6E-06	-
Benzene	82880	269.3	-0.206	0.0391	-1.3E-05	-
Ethylbenzene	29920	360.63	1.124	0.0554	-1.8E-05	-
H2	0	130.7	3.249	0.0004	-	8.3E-07

The standard enthalpy of the overall benzene alkylation with ethane:

$$\begin{aligned}\Delta H_{\text{rxn}}(298\text{K}) &= \Delta H_{\text{EB}} + \Delta H_{\text{H}_2} - \Delta H_{\text{C}_2} - \Delta H_{\text{Ben}} \\ &= 29920 + 0 - 82880 - (-84000) \\ &= 31040 \text{ (J/mol)}\end{aligned}$$

The standard entropy of the overall benzene alkylation with ethane:

$$\begin{aligned}\Delta S_{\text{rxn}}(298\text{K}) &= \Delta S_{\text{EB}} + \Delta S_{\text{H}_2} - \Delta S_{\text{C}_2} - \Delta S_{\text{Ben}} \\ &= 360.63 + 130.7 - 269.3 - 229.2 \\ &= -7.17 \text{ (J/molK)}\end{aligned}$$

The overall reaction enthalpy at 723K:

$$\begin{aligned}\Delta H_{723} &= \Delta H_{298} + \int_{298}^{723} C_p dT \\ &= \Delta H_{298} + \left(\int_{298}^{723} a + bT + cT^2 + \frac{d}{T^2} dT \right) \times R \\ &= 39113.2 \text{ J/mol}\end{aligned}$$

The overall reaction entropy at 723K:

$$\begin{aligned}\Delta S_{723} &= \Delta S_{298} + \int_{298}^{723} \frac{C_p}{T} dT \\ &= \Delta S_{298} + \left(\int_{298}^{723} \frac{a}{T} + b + cT + \frac{d}{T^3} dT \right) \times R \\ &= 10.84 \text{ J/molK}\end{aligned}$$

The Gibbs Energy of the reaction:

$$\begin{aligned}\Delta G_r &= \Delta H_r - T_r \Delta S_r \\ &= 39113.2 - 723 \cdot 10.84 \\ &= 31275.88 \text{ (J/mol)}\end{aligned}$$

The equilibrium constant of the reaction:

$$\begin{aligned}\ln K_p &= \frac{-\Delta G_r}{RT_r} \\ &= -31275.88 / (8.314 \cdot 723) \\ &= -5.2030\end{aligned}$$

$$K_p = 0.0055$$

The equilibrium conversion of benzene:

$$X_{\text{ben}} = 20\%$$

A1.2. Ethane dehydrogenation reaction

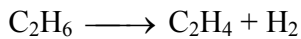

Table A1.2. Thermodynamics data at 298K (Yaw, 1992).

Components	C _p (J/molK)	ΔH (J/mol)	ΔS (J/molK)
C2 (g)	52.5	-84000	229.2
C2=(g)	42.9	52400	219.3
H2 (g)	28.8	0	130.7

The standard enthalpy of the overall ethane dehydrogenation reaction:

$$\begin{aligned}\Delta H_{\text{rxn}} (298\text{K}) &= \Delta H_{\text{C}_2=} + \Delta H_{\text{H}_2} - \Delta H_{\text{C}_2} \\ &= 136400 \text{ (J/mol)}\end{aligned}$$

The standard entropy of the overall ethane dehydrogenation reaction:

$$\begin{aligned}\Delta S_{\text{rxn}} (298\text{K}) &= \Delta S_{\text{C}_2=} + \Delta S_{\text{H}_2} - \Delta S_{\text{C}_2} \\ &= 120.8 \text{ (J/molK)}\end{aligned}$$

The overall reaction enthalpy at 723K:

$$\begin{aligned}\Delta H_{\text{rxn}}(723\text{K}) &= \Delta H_{\text{rxn}}(298\text{K}) + C_p (T_r - T_{298\text{K}})_{(\text{products} - \text{reactants})} \\ &= 144560 \text{ (J/mol)}\end{aligned}$$

The overall reaction entropy at 723K:

$$\begin{aligned}\Delta S_{\text{rxn}}(723\text{K}) &= \Delta S_{\text{rxn}}(298\text{K}) + C_p \ln(T_r/T_{298\text{K}})_{(\text{products} - \text{reactants})} \\ &= 137.82 \text{ (J/molK)}\end{aligned}$$

The Gibbs Energy of the reaction:

$$\begin{aligned}\Delta G_r &= \Delta H_r - T_r \Delta S_r \\ &= 144560 - 723 * 137.82 \\ &= 44916.14 \text{ (J/mol)}\end{aligned}$$

The equilibrium constant of the reaction:

$$\begin{aligned}\ln K_p &= \frac{-\Delta G_r}{RT_r} \\ &= -44916.14 / (8.314 * 723) \\ &= -7.4723\end{aligned}$$

$$K_p = 0.000568$$

The equilibrium conversion of ethane;

$$X_{\text{C}_2} = 2.4\%$$

Appendix 2: List of Publications

- A2.1. Wong KS, Vazhnova T, Rigby SP, Lukyanov DB, (2008), “Effect of reaction temperature on benzene alkylation with ethane into ethylbenzene over PtH-ZSM-5 bifunctional catalyst”. 20th International Symposium on Chemical Reaction Engineering (ISCRE 20), 7 – 10 September 2008, Kyoto; Oral presentation, Book of Abstract, p. 258-259 (2H07).
- A2.2. Wong KS, Vazhnova T, Lukyanov DB, (2008), “Alkylation of benzene with ethane into ethylbenzene over PtH-ZSM-5 bifunctional catalyst at low temperatures”. 5th International Conference on Environmental Catalysis, 31 August – 3 September 2008, Belfast; Oral presentation, Programme and Abstracts, GC-8.
- A2.3. Wong KS, Vazhnova T, Lukyanov DB, (2008), “Alkylation of benzene with ethane into ethylbenzene over PtH-ZSM-5 bifunctional catalyst at low and high reaction temperatures”. 14th International Congress on Catalysis, 13 – 18 July 2008, Seoul; Poster, Book of Abstracts, PIII-51-72; Extended Abstracts (CD-ROM), PIII-51-72.
- A2.4. Wong KS, Vazhnova T, Rigby SP, Lukyanov DB, (2008). “Selective and Stable Alkylation of Benzene with Ethane into Ethylbenzene over PtH-ZSM-5 Bifunctional Catalyst”. 31st Annual Meeting of British Zeolite Association, 31 March – 2 April 2008, Keele; Oral presentation, Programme and Abstracts, OP10.
- A2.5. Wong KS, Vazhnova T, Lukyanov DB, (2008). “Direct Benzene Alkylation with Ethane over Highly Selective Bifunctional Catalysts”. Presented as a poster at Catalysis: Fundamentals and Practice, 3 – 7 September 2007, Liverpool.

A2.1. Effect of reaction temperature on benzene alkylation with ethane into ethylbenzene over PtH-ZSM-5 bifunctional catalyst

K. S. Wong, T. Vazhnova, Rigby SP, and D. B. Lukyanov

Catalysis and Reaction Engineering Group, Department of Chemical Engineering, University of Bath, Bath, BA2 7AY, United Kingdom.

1. Introduction

Ethylbenzene (EB), the primary feedstock for the synthesis of polystyrene, is currently produced via acid catalysed benzene alkylation with ethene¹⁾, which is a product of highly endothermic and energy demanding reactions, such as steam reforming of ethane and naphtha^{2,3)}. The novel catalytic reaction pathway, which uses ethane for benzene alkylation, instead of ethene, would eliminate the ethene production step, thus, leading to the commercial and environmental benefits in the EB manufacturing. Obviously, a new process would be commercially viable only if high EB selectivity and catalyst stability are achieved. Recently, Lukyanov and Vazhnova⁴⁾ have demonstrated the feasibility of the highly selective and stable benzene alkylation with ethane into EB using Pt-containing H-ZSM-5 catalysts at 370°C. It was suggested that the low reaction temperature limits the formation of ethene (and other alkenes) and, as a result, suppresses various side reactions, including coke formation. However, no attempt was made in this work⁴⁾ to optimise further the reaction temperature. The aim of the present study was to perform in-depth investigation of benzene alkylation with ethane into EB over a PtH-ZSM-5 catalyst in a temperature range of 290-450°C, in order to establish the effect of the temperature on the reaction pathways and catalyst performance, thus, determining the most optimum reaction temperature.

2. Methods and Materials

Pt-containing (1 wt.%) H-ZSM-5 bifunctional catalyst, defined as PtH-ZSM-5, was prepared by incipient wetness impregnation of the parent H-ZSM-5 (Si/Al = 40) zeolite, using aqueous solution of tetraammine-platinum (II) nitrate, $\text{Pt}(\text{NH}_3)_4(\text{NO}_3)_2$. The benzene alkylation with ethane was studied at atmospheric pressure in a continuous flow reactor at the reaction temperatures of 290, 330, 370, 410, and 450°C. The feed comprised 90 mol.% ethane and 10 mol.% benzene. The details of the catalyst preparation and kinetic studies are described elsewhere⁴⁾, and the weight hour space velocity (WHSV) is defined as the total feed mass flowrate divided by the catalyst mass.

3. Results and Discussion

3.1 Catalyst Stability

Fig. 1 shows one set of the time on stream data generated during the investigation of the catalyst stability at different temperatures. The highest benzene conversion obtained at 290°C was 3%, which clearly indicates that the catalyst has very low activity at this temperature. Hence, the catalyst performance at 290°C will not be discussed in the abstract (but will be considered in the presentation). Fig. 1 reveals very stable catalyst performance in benzene alkylation with ethane into EB at 330, 370 and 410°C. Indeed, no changes were observed at these temperatures in benzene conversion during nearly 50 h on stream. Lower catalyst stability was observed at 450°C, where benzene conversion decreased from 12% to 10% over 48 h on stream. The catalyst deactivation at 450°C could be due to

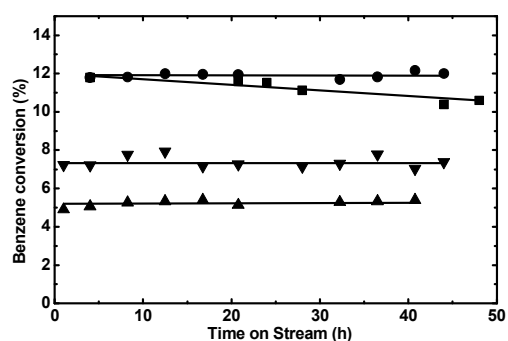

Fig. 1. Effect of time on stream on benzene conversion over PtH-ZSM-5 catalyst at 330 (▲), 370 (▼), 410 (●) and 450°C (■).

the higher rate of coke formation at this temperature when compared with the lower temperatures.

3.2 Catalyst Activity and Selectivity

The catalyst performance was investigated using different WHSV. The results reveal similar reaction pathways of benzene alkylation with ethane into EB at all temperatures studied in this work. However, it is shown that temperature has different effects on the rates of the different reaction steps, and this leads to the different product distributions.

Table 1 demonstrates that the highest EB selectivity is achieved at 330°C. However, the WHSV at 330°C is about 9 times lower than the WHSV at 370°C for the similar benzene conversion (~8.5%). This makes clear that the catalyst activity is fairly low at 330°C, and, as a result, this temperature might not be the most optimum temperature even though the EB selectivity is as high as 94.7 mol.%. The benzene alkylation with ethane into EB achieved high EB selectivity (91.5 mol.%) with low side products selectivities (isopropylbenzene (iPB), toluene, ethyltoluene, etc.) at 370°C. The decrease in the EB selectivity with temperature is likely to be associated with the higher rate of formation of the side products (e.g. iPB) at high temperatures, as it follows from Table 1.

Table 1. Selectivities to all aromatic products of benzene alkylation with ethane over PtH-ZSM-5 catalyst at different reaction temperatures.

Temperature (°C)	330	370	410	450
WHSV (h ⁻¹)	0.72	6.34	15.28	20.83
Ethane conversion (%)	0.98	1.25	1.86	3.20
Benzene conversion (%)	8.11	8.75	8.31	9.15
Selectivity (mol.%)				
Toluene	1.59	0.58	0.27	0.34
Ethylbenzene	94.68	91.51	89.84	87.69
Isopropylbenzene	0.69	3.17	6.75	8.70
Ethyltoluene	0.21	0.27	0.29	0.48
Diethylbenzenes	1.51	1.96	2.06	2.06
Triethylbenzene	1.26	1.64	0.42	0.10
Other aromatics	0.06	0.87	0.37	0.63

4. Conclusions

Similar reaction pathways operate in the temperature range of 290-450°C, but the temperature has different effects on the rates of the different reaction steps, leading to the different product distributions at different temperatures. Taking into consideration catalyst activity and selectivity, we can conclude that 370°C is the optimum temperature, at which very stable catalyst performance (46 h on stream) is observed and the EB selectivity above 90 mol.% is achieved at benzene conversion of 12.5%, which is very close to the maximum equilibrium conversion of benzene into EB at this temperature (13.6%).

Acknowledgements

This project was supported by the Engineering and Physical Sciences Research Council (EPSRC) of the UK (grant EP/C532554/1).

References

1. T.F. Degnan Jr., C.M. Smith, & C.R. Venkat, *Appl. Catal. A*, **221**, 283-294 (2001).
2. J.A. Moulijn, M. Makkee & A. van Diepen, *Chemical Process Technology*, John Wiley & Sons, Chichester, Chapter 4 (2001).
3. J. Towfighi, H. Zimmermann, R. Karimzadeh, & M.M. Akbarnejad, *Ind. Eng. Chem. Res.*, **41**, 1419-1424 (2002).
4. D.B. Lukyanov & T. Vazhnova, *J. Mol. Catal. A: Chem.*, **279**, 128-132 (2008).

A2.2. Alkylation of benzene with ethane into ethylbenzene over PtH-ZSM-5 bifunctional catalyst at low temperatures

K. S. Wong, T. Vazhnova and D. B. Lukyanov*

Department of Chemical Engineering, University of Bath, Bath, BA2 7AY, United Kingdom

*Corresponding author. Tel: +44 1225 383329, Fax: +44 1225 5713 E-mail: D.B.Lukyanov@bath.ac.uk

Background

Ethylbenzene (EB), the primary feedstock for the synthesis of polystyrene, is currently produced via acid catalysed benzene alkylation with ethene [1], which is a product of highly endothermic and energy intensive processes [2]. The new catalytic reaction, which uses ethane for benzene alkylation, instead of ethene, would eliminate the ethene production step, thus, minimising the energy consumption in the EB manufacturing and leading to the reduction of CO₂ emissions. The aim of the present work was to perform in-depth investigation of benzene alkylation with ethane into EB over a PtH-ZSM-5 catalyst at low temperatures (290-410°C) in order to establish the effect of temperature on the reaction pathways and catalyst performance, thus, determining the optimum reaction temperature.

Results

Benzene alkylation with ethane over Pt (1 wt.%) supported H-ZSM-5 (Si/Al = 40) bifunctional catalyst was studied at atmospheric pressure in a continuous flow reactor at 290, 330, 370 and 410°C. Our results show very stable catalyst performance at all four temperatures, with no changes in benzene conversion during nearly 50 hours on stream. Similar reaction pathways of benzene alkylation with ethane into EB were established at all temperatures, based on the kinetic data obtained at different feed conversions. As expected, the catalyst activity was increasing with increasing temperature. However, it is shown that temperature has different effects on the rates of the different reaction steps, and this leads to the different product distributions. Taking into consideration catalyst activity and selectivity, we can conclude that 370°C is the optimum temperature, at which very stable catalyst performance (46 h on stream) is observed and the EB selectivity above 90 mol.% is achieved at benzene conversion of 12.5%, which is very close to the maximum equilibrium conversion of benzene into EB at this temperature (13.6%). At lower temperatures (290 and 330°C), the catalyst activity was significantly lower than at 370°C, while at 410°C a decrease in the EB selectivity was observed.

Justification for acceptance

Direct alkylation of benzene with ethane into EB represents a new, environmentally benign process of EB production. Our work reveals the pathways of this reaction and demonstrates its potential for EB manufacturing.

References

[1] T.F. Degnan Jr., C.M. Smith, C.R. Venkat, *Appl. Catal. A: Gen.* 221 (2001) 283.

[2] J.A. Moulijn, M. Makkee, A. van Diepen, *Chemical Process Technology*, John Wiley & Sons, Chichester, Chapter 4 (2001).

A2.3. Alkylation of benzene with ethane into ethylbenzene over PtH-ZSM-5 bifunctional catalyst at low and high reaction temperatures

Kae S. Wong, Tanya Vazhnova, Dmitry B. Lukyanov*

Department of Chemical Engineering, University of Bath, Bath, BA2 7AY, UK

**Corresponding author: Fax number +44 (0) 1225 385713, E-mail address D.B.Lukyanov@bath.ac.uk*

Abstract: *Benzene alkylation with ethane into ethylbenzene (EB) over bifunctional Pt-containing H-ZSM-5 catalyst was studied at low (370 °C) and high (490 °C) reaction temperatures. Excellent catalyst performance, in terms of stability (up to 48 h on stream), activity (benzene conversion of 12.5%) and EB selectivity (above 90 mol.% in the aromatic products), was achieved at 370 °C. Similar reaction pathways operate at 370 and 490 °C, but the temperature has different effects on the rates of the different reaction steps. This leads to the lower EB selectivity and catalyst stability at the high reaction temperature.*

Keywords: Ethylbenzene, Alkylation, Bifunctional catalysts.

1. Introduction

Ethylbenzene (EB), the primary feedstock for the synthesis of polystyrene, is currently produced via acid catalyzed benzene alkylation with ethene,¹ which is a product of highly endothermic and energy demanding reactions (steam reforming of ethane and naphtha).^{2,3} The replacement of ethene with ethane, as the alkylating agent in the EB synthesis, would eliminate the ethene production step, thus, leading to the commercial and environmental benefits in the EB manufacturing. Obviously, a new process would be commercially viable only if high EB selectivity and catalyst stability are achieved. Recently, Lukyanov and Vazhnova have demonstrated⁴ the feasibility of the highly selective and stable benzene alkylation with ethane into EB using Pt-containing H-ZSM-5 catalysts at 370 °C. It was suggested that the low reaction temperature limits the formation of ethene (and other alkenes) and, as a consequence, suppresses various side reactions, including coke formation. However, no attempt was made in this work⁴ to investigate benzene alkylation with ethane at other (higher) temperatures. The aim of the present work was to perform in-depth investigation of benzene alkylation with ethane into EB over a PtH-ZSM-5 catalyst at low (370 °C) and high (490 °C) temperatures in order to establish the effect of the reaction temperature on the reaction pathways and catalyst performance, in terms of selectivity, stability, etc.

2. Experimental

Pt-containing (1 wt.%) H-ZSM-5 bifunctional catalyst, defined as PtH-ZSM-5, was prepared by incipient wetness impregnation of the parent H-ZSM-5 (Si/Al = 40) zeolite, using aqueous solution of tetraammine-platinum (II) nitrate, $\text{Pt}(\text{NH}_3)_4(\text{NO}_3)_2$. The benzene alkylation with ethane was studied at atmospheric pressure in a continuous flow reactor at the reaction temperatures of 370 and 490 °C. The feed comprised 90 mol.% ethane and 10 mol.% benzene. The details of the catalyst preparation and kinetic studies are described elsewhere.⁴ Different conversions were obtained in the experiments that were carried out at different contact times.

3. Results and discussion

Figure 1 shows very stable performance of the catalyst during benzene alkylation with ethane into EB at 370 °C. A decrease in benzene conversion from 9 to 6%, which is observed at 490 °C during 22 h on stream, indicates clearly that the catalyst deactivation is taking place at this temperature. Alkenes are known as important contributors to the coke formation that leads to catalyst deactivation.⁴ Table 1 shows higher ethene (as well as propene and butenes) selectivity at 490 °C, suggesting that the low catalyst stability at 490 °C could be associated with a higher rate of coke formation at this temperature (in comparison with 370 °C).

Table 1 highlights that at the same benzene conversions (~11%), the EB selectivity at 370 °C is about 4 times higher than the EB selectivity at 490 °C. This indicates that the production of EB is dominating at 370 °C, where ethene reacts readily with benzene forming EB. The low propene and butenes selectivities at 370 °C illustrate further that ethene is being consumed mainly in the alkylation reaction but not in the side reactions such as alkene oligomerization, aromatization, etc. The high ethane conversion (5.25%) and ethene selectivity (77 mol.%) at 490 °C (Table 1) demonstrate that large amount of ethane is converted into ethene due to higher thermodynamic equilibrium conversion at this temperature, but only small fraction of ethene reacts with benzene to form EB.

4. Conclusions

Benzene alkylation with ethane into EB over PtH-ZSM-5 catalyst proceeds via similar reaction pathways at 370 and 490 °C, but the reaction temperature has different effects on the rates of the different reaction steps. As a result, the catalyst demonstrates excellent performance at 370 °C, but lower catalyst stability and EB selectivity are observed at 490 °C.

References

1. T.F. Degnan Jr., C.M. Smith, C.R. Venkat, *Appl. Catal. A: Gen.* 221 (2001) 283.
2. J.A. Moulijn, M. Makkee, A. van Diepen, "Chemical Process Technology", John Wiley & Sons, Chichester, 2001, Chapter 4.
3. J. Towfighi, H. Zimmermann, R. Karimzadeh, M.M. Akbarnejad, *Ind. Eng. Chem. Res.* 41 (2002) 1419.
4. D.B. Lukyanov, T. Vazhnova, *J. Mol. Catal. A: Chem.* (2007), doi: 10.1016/j.molcata.2007.10.016.

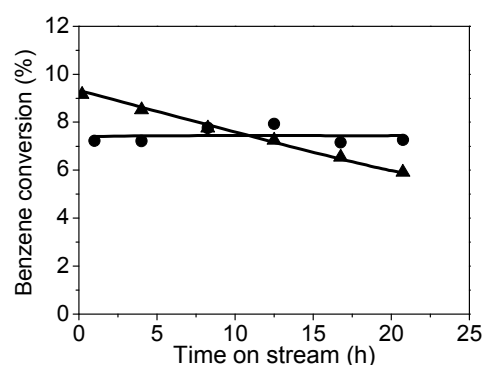

Figure 1. Effect of time on stream on benzene conversion over PtH-ZSM-5 catalyst at 370 °C (●) and 490 °C (▲).

Table 1. Selectivities to all carbon containing products of benzene alkylation with ethane over PtH-ZSM-5 catalyst at 370 and 490 °C.

Reaction temperature	370 °C	490 °C
Ethane conversion (%)	1.57	5.25
Benzene conversion (%)	11.08	11.03
Selectivity (mol.%)		
Methane	0.39	0.39
Ethene	14.27	77.12
Propane	2.47	0.18
Propene	0.11	0.57
Butanes	0.18	0.07
Butenes	0	0.22
Toluene	0.82	0.12
Ethylbenzene	75.33	18.99
Xylenes	0.09	0.05
Propylbenzenes	2.02	1.61
Ethyltoluenes	0.39	0.08
Diethylbenzenes	1.87	0.39
Triethylbenzenes	1.97	0.06

A2.4. Selective and Stable Alkylation of Benzene with Ethane into Ethylbenzene over PtH-ZSM-5 Bifunctional Catalyst

K. S. Wong, T. Vazhnova, Rigby SP, D. B. Lukyanov

Department of Chemical Engineering, University of Bath, Bath, BA2 7AY, UK

Ethylbenzene (EB), the primary feedstock for the synthesis of polystyrene, is currently produced via acid catalysed benzene alkylation with ethene, which is a product of highly endothermic and energy intensive processes. The new reaction, which uses ethane for benzene alkylation, instead of ethene, would eliminate the ethene production step, thus, leading to the commercial and environmental benefits in the EB manufacturing. Benzene alkylation with ethane into EB can be achieved using bifunctional zeolite catalysts, which combine ethane dehydrogenation into ethene over metal sites with benzene alkylation by ethene over Brønsted acid sites. This work was focused on in-depth investigation of benzene alkylation with ethane into EB over a PtH-ZSM-5 catalyst at different temperatures (290-410°C) in order to establish the effect of temperature on the reaction pathways and catalyst performance, thus determining the optimum reaction temperature.

Benzene alkylation with ethane over Pt (1 wt.%) supported H-ZSM-5 (Si/Al = 40) bifunctional catalyst was studied at atmospheric pressure in a continuous flow reactor at 290, 330, 370 and 410°C. Our results show very stable catalyst performance at all four temperatures, with no changes in benzene conversion during nearly 50 hours on stream. Similar reaction pathways of benzene alkylation with ethane into EB were established at all temperatures, based on the kinetic data obtained at different feed conversions. As expected, the catalyst activity was increasing with increasing temperature. However, it has been shown that temperature has different effects on the rates of the different reaction steps, and this leads to the different product distributions. Excellent catalyst performance, in terms of stability (up to 48 h on stream), activity (benzene conversion of 12.5%, which is very close to the maximum equilibrium conversion of benzene into EB at this temperature, 13.6%) and EB selectivity (above 90 mol.% in the aromatic products), was achieved at 370°C. At lower temperatures (290 and 330°C), the catalyst activity was significantly lower than at 370°C, while at 410°C a decrease in the EB selectivity was observed.

The authors gratefully acknowledge the financial support for this work from EPSRC (grant EP/C532554).

Appendix 3: Experimental data of benzene alkylation with ethane
A3.1. Concentrations (mol.%) of products produced over 1PtH-ZSM-5(80) catalyst at 290°C

Table: Mole%

Date: 29/06/07

Conversion of ethane-benzene over 1%Pt/HZSM5(80)-05 catalyst at 290oC.

Feed: 90mol% ethane, 10mol% Benzene

Comments: TOS, cat. weight = 0.0509g

Feed flowrate = Ethane 16 ml/min

Experiment	401-ETH	402-ETH	402-ETH0	402-ETH0	402-ETH0	403-ETH
Temper., °C	290	290	290	290	290	290
Tsat, oC	20.0	20.0	20.0	20.0	20.0	19.5
TOS, h	1.00	4.00	8.25	12.50	16.75	20.30
WHSV, h ⁻¹	29.47	29.86	29.86	29.86	29.86	30.06
Cont.time,h	0.0339	0.0335	0.0335	0.0335	0.0335	0.0333
Conv. C2	0.118	0.121	0.116	0.114	0.113	0.111
Conv Benz	0.274	0.263	0.248	0.233	0.230	0.226
S1(E+B=E)	12.08	11.52	11.03	10.61	10.38	10.68
S2(B=EB)	100.00	100.00	100.00	100.00	100.00	100.00
S3(C2=)	37.14	38.29	39.60	39.97	39.50	40.57
S4 (H2)	50.07	49.46	48.63	48.67	49.36	47.97
S5 (DEBs)	0.00	0.00	0.00	0.00	0.00	0.00
S6 (TEB)	0.00	0.00	0.00	0.00	0.00	0.00
S7 (S2+S5)	100.00	100.00	100.00	100.00	100.00	100.00
Yield Et-Be	0.274	0.263	0.248	0.233	0.230	0.226
H2	0.1051	0.1047	0.0980	0.0966	0.0980	0.0910
C1	0.0000	0.0000	0.0000	0.0000	0.0000	0.0000
C2	90.5307	90.5028	90.8149	90.7405	90.8073	90.8204
C2=	0.0779	0.0810	0.0798	0.0793	0.0784	0.0770
C3	0.0000	0.0000	0.0000	0.0000	0.0000	0.0000
C3=	0.0000	0.0000	0.0000	0.0000	0.0000	0.0000
i-C4	0.0000	0.0000	0.0000	0.0000	0.0000	0.0000
n-C4	0.0000	0.0000	0.0000	0.0000	0.0000	0.0000
trans -C4=	0.0000	0.0000	0.0000	0.0000	0.0000	0.0000
1-C4=	0.0000	0.0000	0.0000	0.0000	0.0000	0.0000
iso-C4=	0.0000	0.0000	0.0000	0.0000	0.0000	0.0000
cis-C4=	0.0000	0.0000	0.0000	0.0000	0.0000	0.0000
C5	0.0000	0.0000	0.0000	0.0000	0.0000	0.0000
18.9170	0.0015	0.0015	0.0015	0.0015	0.0015	0.0015
Benzene	9.2595	9.2856	8.9836	9.0611	8.9943	8.9898
Toluene	0.0000	0.0000	0.0000	0.0000	0.0000	0.0000
Et-Benzene	0.0253	0.0244	0.0222	0.0210	0.0206	0.0203
m/p Xylene	0.0000	0.0000	0.0000	0.0000	0.0000	0.0000
o-Xylene	0.0000	0.0000	0.0000	0.0000	0.0000	0.0000
iPB	0.0000	0.0000	0.0000	0.0000	0.0000	0.0000
PB	0.0000	0.0000	0.0000	0.0000	0.0000	0.0000
Et-Toluene	0.0000	0.0000	0.0000	0.0000	0.0000	0.0000
A	0.0000	0.0000	0.0000	0.0000	0.0000	0.0000
B	0.0000	0.0000	0.0000	0.0000	0.0000	0.0000
1,3-DEB	0.0000	0.0000	0.0000	0.0000	0.0000	0.0000
1,4-DEB	0.0000	0.0000	0.0000	0.0000	0.0000	0.0000
1,2-DEB	0.0000	0.0000	0.0000	0.0000	0.0000	0.0000
TEB	0.0000	0.0000	0.0000	0.0000	0.0000	0.0000
SUM DEB	0.0000	0.0000	0.0000	0.0000	0.0000	0.0000
SUM Xyl	0.0000	0.0000	0.0000	0.0000	0.0000	0.0000
Total	100.0000	100.0000	100.0000	100.0000	100.0000	100.0000

Table: Mole%

Date: 29/06/07

Conversion of ethane-benzene over 1%Pt/HZSM5(80)-05 catalyst at 290oC.

Feed: 90mol% ethane, 10mol% Benzene

Comments: TOS, cat. weight = 0.0509g

Feed flow: 8 ml/min 64 ml/min

Experiment	404-ETH	405-ETH
Temper., °C	290	290
Tsat, oC	19.5	20.0
TOS, h	21.60	22.80
WHSV, h ⁻¹	14.15	125.54
Cont.time,h	0.0707	0.0080
Conv. C2	0.134	0.057
Conv Benz	0.485	0.033
S1(E+B=E)	18.99	2.95
S2(B=EB)	100.00	100.00
S3(C2=)	32.10	46.75
S4 (H2)	48.28	48.76
S5 (DEBs)	0.00	0.00
S6 (TEB)	0.00	0.00
S7 (S2+S5)	100.00	100.00
Yield Et-Be	0.485	0.033
H2	0.1119	0.0475
C1	0.0000	0.0000
C2	90.6841	91.2190
C2=	0.0744	0.0455
C3	0.0000	0.0000
C3=	0.0000	0.0000
i-C4	0.0000	0.0000
n-C4	0.0000	0.0000
trans -C4=	0.0000	0.0000
1-C4=	0.0000	0.0000
iso-C4=	0.0000	0.0000
cis-C4=	0.0000	0.0000
C5	0.0000	0.0000
18.9170	0.0015	0.0015
Benzene	9.0842	8.6837
Toluene	0.0000	0.0000
Et-Benzene	0.0440	0.0029
m/p Xylene	0.0000	0.0000
o-Xylene	0.0000	0.0000
iPB	0.0000	0.0000
PB	0.0000	0.0000
Et-Toluene	0.0000	0.0000
A	0.0000	0.0000
B	0.0000	0.0000
1,3-DEB	0.0000	0.0000
1,4-DEB	0.0000	0.0000
1,2-DEB	0.0000	0.0000
TEB	0.0000	0.0000
SUM DEB	0.0000	0.0000
SUM Xyl	0.0000	0.0000
Total	100.0000	100.0000

Table: Mole%

Date: 24/06/07

Conversion of ethane-benzene over 1%Pt/HZSM5(80)-05 catalyst at 290oC.

Feed: 90mol% ethane, 10mol% Benzene

Comments: TOS, cat. weight = 1.0004g

Feed flowrate = Ethane 16 ml/min

8 ml/min

Experiment	391-ETH	392-ETH	392-ETH0	392-ETH0	392-ETH0	393-ETH	394-ETH
Temper., °C	290	290	290	290	290	290	290
Tsat, oC	20.0	20.0	20.0	20.0	20.0	20.0	20.0
TOS, h	1.00	4.00	8.25	12.50	16.75	19.00	20.50
WHSV, h ⁻¹	1.53	1.52	1.52	1.52	1.52	1.56	0.77
Cont.time,h	0.6536	0.6579	0.6579	0.6579	0.6579	0.6410	1.2987
Conv. C2	0.250	0.262	0.275	0.274	0.277	0.285	0.364
Conv Benz	2.052	2.187	2.386	2.416	2.505	2.513	3.254
S1(E+B=E)	33.37	36.86	39.36	40.20	40.39	40.88	40.97
S2(B=EB)	96.72	97.35	97.56	97.66	97.52	97.46	97.06
S3(C2=)	3.91	4.41	4.63	4.93	4.99	4.91	2.72
S4 (H2)	60.50	56.77	54.15	53.06	52.73	52.32	54.15
S5 (DEBs)	0.77	0.92	0.94	0.92	1.07	1.19	1.44
S6 (TEB)	0.00	0.00	0.00	0.00	0.00	0.00	0.00
S7 (S2+S5)	97.49	98.26	98.49	98.58	98.59	98.65	98.50
Yield Et-Be	1.984	2.129	2.327	2.360	2.443	2.450	3.158
H2	0.3339	0.3041	0.2905	0.2778	0.2777	0.2806	0.3819
C1	0.0000	0.0000	0.0000	0.0000	0.0000	0.0000	0.0000
C2	90.2929	90.3219	90.5437	90.7075	90.9175	90.6696	90.3674
C2=	0.0216	0.0236	0.0248	0.0258	0.0263	0.0263	0.0192
C3	0.0051	0.0043	0.0040	0.0038	0.0038	0.0038	0.0058
C3=	0.0000	0.0000	0.0000	0.0000	0.0000	0.0000	0.0000
i-C4	0.0000	0.0000	0.0000	0.0000	0.0000	0.0000	0.0000
n-C4	0.0009	0.0008	0.0007	0.0006	0.0007	0.0007	0.0007
trans -C4=	0.0000	0.0000	0.0000	0.0000	0.0000	0.0000	0.0000
1-C4=	0.0000	0.0000	0.0000	0.0000	0.0000	0.0000	0.0000
iso-C4=	0.0000	0.0000	0.0000	0.0000	0.0000	0.0000	0.0000
cis-C4=	0.0000	0.0000	0.0000	0.0000	0.0000	0.0000	0.0000
C5	0.0000	0.0000	0.0000	0.0000	0.0000	0.0000	0.0000
18.9170	0.0000	0.0000	0.0000	0.0000	0.0000	0.0000	0.0000
Benzene	9.1551	9.1424	8.9199	8.7689	8.5558	8.7941	8.9273
Toluene	0.0041	0.0027	0.0023	0.0021	0.0020	0.0020	0.0033
Et-Benzene	0.1842	0.1975	0.2111	0.2105	0.2127	0.2192	0.2889
m/p Xylene	0.0000	0.0000	0.0000	0.0000	0.0000	0.0000	0.0000
o-Xylene	0.0000	0.0000	0.0000	0.0000	0.0000	0.0000	0.0000
iPB	0.0006	0.0008	0.0009	0.0010	0.0011	0.0010	0.0011
PB	0.0000	0.0000	0.0000	0.0000	0.0000	0.0000	0.0000
Et-Toluene	0.0000	0.0000	0.0000	0.0000	0.0000	0.0000	0.0000
A	0.0000	0.0000	0.0000	0.0000	0.0000	0.0000	0.0000
B	0.0000	0.0000	0.0000	0.0000	0.0000	0.0000	0.0000
1,3-DEB	0.0009	0.0011	0.0012	0.0012	0.0015	0.0016	0.0033
1,4-DEB	0.0006	0.0007	0.0008	0.0008	0.0009	0.0011	0.0010
1,2-DEB	0.0000	0.0000	0.0000	0.0000	0.0000	0.0000	0.0000
TEB	0.0000	0.0000	0.0000	0.0000	0.0000	0.0000	0.0000
SUM DEB	0.0015	0.0019	0.0020	0.0020	0.0023	0.0027	0.0043
SUM Xyl	0.0000	0.0000	0.0000	0.0000	0.0000	0.0000	0.0000
Total	100.0000	100.0000	100.0000	100.0000	100.0000	100.0000	100.0000

Table: Mole%

Date: 24/06/07

Conversion of ethane-benzene over 1%Pt/HZSM5(80)-05 catalyst at 290oC.

Feed: 90mol% ethane, 10mol% Benzene

Comments: TOS, cat. weight = 1.0004g

Feed flow: 4 ml/min 64 ml/min 32 ml/min

Experiment	395-ETH	396-ETH	397-ETH	398-ETH	398-ETH0	398-ETH0	398-ETH0
Temper., °C	290	288	289	290	290	290	290
Tsat, oC	20.0	19.5	20.0	20.0	20.0	20.0	20.0
TOS, h	23.00	26.00	27.00	28.50	32.75	37.00	41.25
WHSV, h ⁻¹	0.36	6.51	3.20	1.51	1.51	1.51	1.51
Cont.time, h	2.7778	0.1536	0.3125	0.6623	0.6623	0.6623	0.6623
Conv. C2	0.432	0.172	0.222	0.285	0.287	0.283	0.288
Conv Benz	3.847	1.221	1.788	2.542	2.584	2.647	2.655
S1(E+B=E)	39.08	33.86	39.77	41.64	41.84	42.42	42.42
S2(B=EB)	97.06	98.45	98.63	97.63	97.55	97.61	97.47
S3(C2=)	1.57	16.16	9.06	5.02	5.02	5.22	5.15
S4 (H2)	57.07	48.78	49.94	51.67	51.46	50.67	50.69
S5 (DEBs)	0.93	0.00	0.00	1.08	1.16	1.15	1.29
S6 (TEB)	0.00	0.00	0.00	0.00	0.00	0.00	0.00
S7 (S2+S5)	97.99	98.45	98.63	98.71	98.71	98.76	98.75
Yield Et-Be	3.734	1.202	1.763	2.482	2.521	2.584	2.588
H2	0.5069	0.1494	0.2009	0.2748	0.2753	0.2644	0.2687
C1	0.0000	0.0000	0.0000	0.0000	0.0000	0.0000	0.0000
C2	90.1065	91.1209	90.6379	90.7030	90.7473	91.0725	90.9439
C2=	0.0139	0.0495	0.0364	0.0267	0.0268	0.0272	0.0273
C3	0.0091	0.0011	0.0020	0.0035	0.0034	0.0034	0.0033
C3=	0.0000	0.0000	0.0000	0.0000	0.0000	0.0000	0.0000
i-C4	0.0000	0.0000	0.0000	0.0000	0.0000	0.0000	0.0000
n-C4	0.0007	0.0000	0.0000	0.0000	0.0000	0.0000	0.0000
trans -C4=	0.0000	0.0000	0.0000	0.0000	0.0000	0.0000	0.0000
1-C4=	0.0000	0.0000	0.0000	0.0000	0.0000	0.0000	0.0000
iso-C4=	0.0000	0.0000	0.0000	0.0000	0.0000	0.0000	0.0000
cis-C4=	0.0000	0.0000	0.0000	0.0000	0.0000	0.0000	0.0000
C5	0.0000	0.0000	0.0000	0.0000	0.0000	0.0000	0.0000
16.4000	0.0000	0.0009	0.0007	0.0000	0.0000	0.0000	0.0000
Benzene	9.0052	8.5728	8.9598	8.7651	8.7178	8.4057	8.5261
Toluene	0.0062	0.0006	0.0011	0.0018	0.0018	0.0016	0.0016
Et-Benzene	0.3472	0.1037	0.1600	0.2215	0.2238	0.2213	0.2248
m/p Xylene	0.0000	0.0000	0.0000	0.0000	0.0000	0.0000	0.0000
o-Xylene	0.0000	0.0000	0.0000	0.0000	0.0000	0.0000	0.0000
iPB	0.0010	0.0010	0.0012	0.0012	0.0012	0.0012	0.0012
PB	0.0000	0.0000	0.0000	0.0000	0.0000	0.0000	0.0000
Et-Toluene	0.0000	0.0000	0.0000	0.0000	0.0000	0.0000	0.0000
A	0.0000	0.0000	0.0000	0.0000	0.0000	0.0000	0.0000
B	0.0000	0.0000	0.0000	0.0000	0.0000	0.0000	0.0000
1,3-DEB	0.0022	0.0000	0.0000	0.0016	0.0018	0.0017	0.0019
1,4-DEB	0.0012	0.0000	0.0000	0.0008	0.0009	0.0009	0.0011
1,2-DEB	0.0000	0.0000	0.0000	0.0000	0.0000	0.0000	0.0000
TEB	0.0000	0.0000	0.0000	0.0000	0.0000	0.0000	0.0000
SUM DEB	0.0033	0.0000	0.0000	0.0025	0.0027	0.0026	0.0030
SUM Xyl	0.0000	0.0000	0.0000	0.0000	0.0000	0.0000	0.0000
Total	100.0000	100.0000	100.0000	100.0000	100.0000	100.0000	100.0000

A3.2. Concentrations (mol.%) of products produced over 1PtH-ZSM-5(80) catalyst at 330°C

Table: Mole%

Date: 20/06/07

Conversion of ethane-benzene over 1%Pt/HZSM5(80)-05 catalyst at 330oC.

Feed: 90mol% ethane, 10mol% Benzene

Comments: TOS, cat. weight = 0.0506g

Feed flowrate = Ethane 16 ml/min

Experiment	381-ETH	382-ETH	382-ETH0	382-ETH0	382-ETH0	383-ETH
Temper., °C	330	330	330	330	330	330
Tsat, oC	20.0	20.0	20.0	20.0	20.0	20.5
TOS, h	1.00	4.00	8.25	12.50	16.75	20.25
WHSV, h ⁻¹	29.45	29.84	29.84	29.84	29.84	30.63
Cont.time, h	0.0340	0.0335	0.0335	0.0335	0.0335	0.0326
Conv. C2	0.308	0.305	0.298	0.292	0.285	0.280
Conv Benz	0.879	0.827	0.774	0.735	0.707	0.694
S1(E+B=E)	14.92	14.70	14.20	13.69	13.36	13.20
S2(B=EB)	98.05	98.62	98.57	98.74	98.81	98.74
S3(C2=)	34.72	35.59	36.09	37.07	37.95	38.01
S4 (H2)	49.80	49.22	49.21	48.77	48.24	48.32
S5 (DEBs)	0.00	0.00	0.00	0.00	0.00	0.00
S6 (TEB)	0.00	0.00	0.00	0.00	0.00	0.00
S7 (S2+S5)	98.05	98.62	98.57	98.74	98.81	98.74
Yield Et-Be	0.861	0.816	0.763	0.726	0.698	0.685
H2	0.2742	0.2645	0.2586	0.2490	0.2387	0.2359
C1	0.0000	0.0000	0.0000	0.0000	0.0000	0.0000
C2	89.9464	89.8037	89.7224	89.8769	90.0530	90.1205
C2=	0.1912	0.1913	0.1896	0.1892	0.1878	0.1855
C3	0.0000	0.0000	0.0000	0.0000	0.0000	0.0000
C3=	0.0000	0.0000	0.0000	0.0000	0.0000	0.0000
i-C4	0.0000	0.0000	0.0000	0.0000	0.0000	0.0000
n-C4	0.0000	0.0000	0.0000	0.0000	0.0000	0.0000
trans -C4=	0.0000	0.0000	0.0000	0.0000	0.0000	0.0000
1-C4=	0.0000	0.0000	0.0000	0.0000	0.0000	0.0000
iso-C4=	0.0000	0.0000	0.0000	0.0000	0.0000	0.0000
cis-C4=	0.0000	0.0000	0.0000	0.0000	0.0000	0.0000
C5	0.0000	0.0000	0.0000	0.0000	0.0000	0.0000
18.9170	0.0015	0.0015	0.0015	0.0015	0.0015	0.0015
Benzene	9.5030	9.6590	9.7522	9.6125	9.4521	9.3914
Toluene	0.0005	0.0000	0.0000	0.0000	0.0000	0.0000
Et-Benzene	0.0821	0.0790	0.0746	0.0699	0.0661	0.0644
m/p Xylene	0.0000	0.0000	0.0000	0.0000	0.0000	0.0000
o-Xylene	0.0000	0.0000	0.0000	0.0000	0.0000	0.0000
iPB	0.0011	0.0011	0.0011	0.0009	0.0008	0.0008
PB	0.0000	0.0000	0.0000	0.0000	0.0000	0.0000
Et-Toluene	0.0000	0.0000	0.0000	0.0000	0.0000	0.0000
A	0.0000	0.0000	0.0000	0.0000	0.0000	0.0000
B	0.0000	0.0000	0.0000	0.0000	0.0000	0.0000
1,3-DEB	0.0000	0.0000	0.0000	0.0000	0.0000	0.0000
1,4-DEB	0.0000	0.0000	0.0000	0.0000	0.0000	0.0000
1,2-DEB	0.0000	0.0000	0.0000	0.0000	0.0000	0.0000
TEB	0.0000	0.0000	0.0000	0.0000	0.0000	0.0000
SUM DEB	0.0000	0.0000	0.0000	0.0000	0.0000	0.0000
SUM Xyl	0.0000	0.0000	0.0000	0.0000	0.0000	0.0000
Total	100.0000	100.0000	100.0000	100.0000	100.0000	100.0000

Table: Mole%

Conversion of ethane-benzene over 1%Pt/HZSM5(80)-05 catalyst at 330oC.

Feed: 90mol% ethane, 10mol% Benzene

Comments: TOS, cat. weight = 0.0506g

Feed flow: 64 ml/min 32 ml/min 96 ml/min

Experiment	384-ETH	385-ETH	386-ETH	387-ETH
Temper., °C	329	329	328	330
Tsat, oC	20.0	20.0	19.5	19.5
TOS, h	21.50	22.75	24.20	26.62
WHSV, h ⁻¹	124.31	63.24	181.23	31.03
Cont.time,h	0.0080	0.0158	0.0055	0.0322
Conv. C2	0.137	0.205	0.091	0.277
Conv Benz	0.094	0.261	0.047	0.688
S1(E+B=E)	3.41	6.58	2.48	13.09
S2(B=EB)	100.00	100.00	100.00	98.83
S3(C2=)	46.89	44.23	47.60	38.33
S4 (H2)	49.09	48.77	49.03	48.12
S5 (DEBs)	0.00	0.00	0.00	0.00
S6 (TEB)	0.00	0.00	0.00	0.00
S7 (S2+S5)	100.00	100.00	100.00	98.83
Yield Et-Be	0.094	0.261	0.047	0.680
H2	0.1182	0.1750	0.0776	0.2315
C1	0.0000	0.0000	0.0000	0.0000
C2	90.9693	90.5638	91.4971	90.2655
C2=	0.1129	0.1588	0.0753	0.1844
C3	0.0000	0.0000	0.0000	0.0000
C3=	0.0000	0.0000	0.0000	0.0000
i-C4	0.0000	0.0000	0.0000	0.0000
n-C4	0.0000	0.0000	0.0000	0.0000
trans -C4=	0.0000	0.0000	0.0000	0.0000
1-C4=	0.0000	0.0000	0.0000	0.0000
iso-C4=	0.0000	0.0000	0.0000	0.0000
cis-C4=	0.0000	0.0000	0.0000	0.0000
C5	0.0000	0.0000	0.0000	0.0000
18.9170	0.0015	0.0015	0.0014	0.0015
Benzene	8.7898	9.0773	8.3447	9.2534
Toluene	0.0000	0.0000	0.0000	0.0000
Et-Benzene	0.0082	0.0236	0.0039	0.0630
m/p Xylene	0.0000	0.0000	0.0000	0.0000
o-Xylene	0.0000	0.0000	0.0000	0.0000
iPB	0.0000	0.0000	0.0000	0.0007
PB	0.0000	0.0000	0.0000	0.0000
Et-Toluene	0.0000	0.0000	0.0000	0.0000
A	0.0000	0.0000	0.0000	0.0000
B	0.0000	0.0000	0.0000	0.0000
1,3-DEB	0.0000	0.0000	0.0000	0.0000
1,4-DEB	0.0000	0.0000	0.0000	0.0000
1,2-DEB	0.0000	0.0000	0.0000	0.0000
TEB	0.0000	0.0000	0.0000	0.0000
SUM DEB	0.0000	0.0000	0.0000	0.0000
SUM Xyl	0.0000	0.0000	0.0000	0.0000
Total	100.0000	100.0000	100.0000	100.0000

Table: Mole%

Date: 16/06/07

Conversion of ethane-benzene over 1%Pt/HZSM5(80)-05 catalyst at 330oC.

Feed: 90mol% ethane, 10mol% Benzene

Comments: TOS, cat. weight = 0.5012g

Feed flowrate = Ethane 16 ml/min

Experiment	371-ETH	372-ETH	372-ETH0	372-ETH0	372-ETH0	373-ETH
Temper., °C	329	329	329	329	329	329
Tsat, oC	20.5	20.5	20.0	20.0	20.0	20.0
TOS, h	1.00	4.00	8.25	12.50	16.75	19.75
WHSV, h ⁻¹	3.05	3.09	3.09	3.09	3.09	3.11
Cont.time, h	0.3279	0.3236	0.3236	0.3236	0.3236	0.3215
Conv. C2	0.690	0.712	0.706	0.673	0.690	0.709
Conv Benz	4.830	5.068	5.265	5.328	5.401	5.137
S1(E+B=E)	32.39	36.30	38.51	38.48	38.72	39.60
S2(B=EB)	90.86	93.24	94.50	94.92	94.84	95.29
S3(C2=)	5.09	5.45	5.83	6.26	6.16	5.97
S4 (H2)	57.27	54.25	52.40	52.21	52.12	51.66
S5 (DEBs)	1.06	1.10	1.19	1.32	1.70	1.57
S6 (TEB)	5.21	3.34	2.24	1.70	1.44	1.22
S7 (S2+S5)	97.14	97.68	97.94	97.94	97.98	98.07
Yield Et-Be	4.389	4.726	4.976	5.058	5.122	4.895
H2	0.7469	0.7041	0.6627	0.6362	0.6498	0.6537
C1	0.0070	0.0032	0.0000	0.0000	0.0000	0.0000
C2	89.2494	89.0221	89.2949	89.8651	89.7006	88.8852
C2=	0.0665	0.0707	0.0738	0.0763	0.0768	0.0755
C3	0.0175	0.0133	0.0117	0.0110	0.0102	0.0095
C3=	0.0000	0.0000	0.0000	0.0000	0.0000	0.0000
i-C4	0.0000	0.0000	0.0000	0.0000	0.0000	0.0000
n-C4	0.0015	0.0012	0.0011	0.0009	0.0009	0.0008
trans -C4=	0.0000	0.0000	0.0000	0.0000	0.0000	0.0000
1-C4=	0.0000	0.0000	0.0000	0.0000	0.0000	0.0000
iso-C4=	0.0000	0.0000	0.0000	0.0000	0.0000	0.0000
cis-C4=	0.0000	0.0000	0.0000	0.0000	0.0000	0.0000
C5	0.0000	0.0000	0.0000	0.0000	0.0000	0.0000
18.9170	0.0000	0.0000	0.0000	0.0000	0.0000	0.0000
Benzene	9.4464	9.6801	9.4404	8.9165	9.0528	9.8494
Toluene	0.0081	0.0052	0.0043	0.0036	0.0033	0.0032
Et-Benzene	0.4225	0.4712	0.4871	0.4689	0.4827	0.5011
m/p Xylene	0.0000	0.0000	0.0000	0.0000	0.0000	0.0000
o-Xylene	0.0000	0.0000	0.0000	0.0000	0.0000	0.0000
iPB	0.0043	0.0056	0.0059	0.0060	0.0061	0.0063
PB	0.0000	0.0000	0.0000	0.0000	0.0000	0.0000
Et-Toluene	0.0009	0.0009	0.0004	0.0006	0.0008	0.0006
A	0.0000	0.0000	0.0000	0.0000	0.0000	0.0000
B	0.0000	0.0000	0.0000	0.0000	0.0000	0.0000
1,3-DEB	0.0034	0.0040	0.0040	0.0045	0.0056	0.0054
1,4-DEB	0.0016	0.0016	0.0022	0.0020	0.0031	0.0029
1,2-DEB	0.0000	0.0000	0.0000	0.0000	0.0000	0.0000
TEB	0.0242	0.0169	0.0116	0.0084	0.0073	0.0064
SUM DEB	0.0050	0.0056	0.0062	0.0065	0.0086	0.0083
SUM Xyl	0.0000	0.0000	0.0000	0.0000	0.0000	0.0000
Total	100.0000	100.0000	100.0000	100.0000	100.0000	100.0000

Table: Mole%

Date: 16/06/07

Conversion of ethane-benzene over 1%Pt/HZSM5(80)-05 catalyst at 330oC.

Feed: 90mol% ethane, 10mol% Benzene

Comments: TOS, cat. weight = 0.5012g

Feed flow: 96 ml/min 48 ml/min 4 ml/min

8 ml/min

Experiment	374-ETH	375-ETH	376-ETH	376-ETH0	376-ETH0	376-ETH0	377-ETH
Temper., °C	326	328	330	330	330	330	330
Tsat, oC	20.0	20.0	20.0	20.0	20.0	20.0	20.0
TOS, h	22.50	25.20	27.85	32.10	36.35	40.50	44.00
WHSV, h ⁻¹	18.75	9.54	0.72	3.11	3.11	3.11	1.50
Cont.time, h	0.0533	0.1048	1.3889	0.3215	0.3215	0.3215	0.6667
Conv. C2	0.339	0.427	0.980	0.687	0.664	0.658	0.864
Conv Benz	1.636	2.708	8.108	5.286	5.328	5.404	7.021
S1(E+B=E)	22.07	31.69	38.80	39.72	40.09	39.82	41.22
S2(B=EB)	97.51	97.03	94.68	95.46	95.80	95.77	95.49
S3(C2=)	26.83	17.21	2.41	6.35	6.75	6.88	3.77
S4 (H2)	50.36	49.69	54.99	51.26	50.60	50.73	52.08
S5 (DEBs)	0.00	0.73	1.51	1.66	1.38	1.77	1.59
S6 (TEB)	0.00	0.00	1.26	0.98	0.91	0.55	1.01
S7 (S2+S5)	97.51	97.76	97.44	98.10	98.08	98.09	98.09
Yield Et-Be	1.595	2.627	7.677	5.046	5.104	5.175	6.704
H2	0.3120	0.3794	1.0302	0.6304	0.5991	0.5989	0.8162
C1	0.0000	0.0000	0.0048	0.0000	0.0000	0.0000	0.0000
C2	90.9028	90.2142	89.3026	89.4795	89.9022	90.1270	89.3551
C2=	0.1662	0.1314	0.0452	0.0780	0.0799	0.0812	0.0592
C3	0.0000	0.0025	0.0243	0.0088	0.0087	0.0087	0.0145
C3=	0.0000	0.0000	0.0000	0.0000	0.0000	0.0000	0.0000
i-C4	0.0000	0.0000	0.0000	0.0000	0.0000	0.0000	0.0000
n-C4	0.0000	0.0000	0.0012	0.0008	0.0008	0.0009	0.0009
trans -C4=	0.0000	0.0000	0.0000	0.0000	0.0000	0.0000	0.0000
1-C4=	0.0000	0.0000	0.0000	0.0000	0.0000	0.0000	0.0000
iso-C4=	0.0000	0.0000	0.0000	0.0000	0.0000	0.0000	0.0000
cis-C4=	0.0000	0.0000	0.0000	0.0000	0.0000	0.0000	0.0000
C5	0.0000	0.0000	0.0000	0.0000	0.0000	0.0000	0.0000
18.9170	0.0011	0.0009	0.0000	0.0000	0.0000	0.0000	0.0000
Benzene	8.4778	9.0222	8.8242	9.2907	8.9137	8.6924	9.0777
Toluene	0.0005	0.0009	0.0122	0.0028	0.0028	0.0026	0.0055
Et-Benzene	0.1367	0.2420	0.7268	0.4885	0.4747	0.4701	0.6459
m/p Xylene	0.0000	0.0000	0.0005	0.0000	0.0000	0.0000	0.0000
o-Xylene	0.0000	0.0000	0.0000	0.0000	0.0000	0.0000	0.0000
iPB	0.0029	0.0047	0.0053	0.0061	0.0061	0.0060	0.0063
PB	0.0000	0.0000	0.0000	0.0000	0.0000	0.0000	0.0000
Et-Toluene	0.0000	0.0000	0.0016	0.0008	0.0007	0.0008	0.0012
A	0.0000	0.0000	0.0000	0.0000	0.0000	0.0000	0.0000
B	0.0000	0.0000	0.0000	0.0000	0.0000	0.0000	0.0000
1,3-DEB	0.0000	0.0018	0.0074	0.0055	0.0044	0.0056	0.0071
1,4-DEB	0.0000	0.0000	0.0037	0.0030	0.0024	0.0031	0.0037
1,2-DEB	0.0000	0.0000	0.0005	0.0000	0.0000	0.0000	0.0000
TEB	0.0000	0.0000	0.0096	0.0050	0.0045	0.0027	0.0068
SUM DEB	0.0000	0.0018	0.0116	0.0085	0.0068	0.0087	0.0108
SUM Xyl	0.0000	0.0000	0.0005	0.0000	0.0000	0.0000	0.0000
Total	100.0000	100.0000	100.0000	100.0000	100.0000	100.0000	100.0000

A3.3. Concentrations (mol.%) of products produced over 1PtH-ZSM-5(80) catalyst at 370°C

Table: Mole%

Date: 7/06/06

Conversion of ethane-benzene over 1%Pt/HZSM5(80)-05 catalyst at 370°C.

Feed: 90mol% ethane, 10mol% Benzene

Comments: TOS, cat. weight = 0.0503g

Feed flowrate = Ethane 16 ml/min

32 ml/min

Experiment	151-ETH	152-ETH	152-ETH0	152-ETH0	152-ETH0	153-ETH	154-ETH
Temper., °C	369	369	369	369	369	369	369
Tsat, °C	20.0	19.0	19.0	19.0	19.0	20.0	20.5
TOS, h	0.20	4.00	8.25	12.50	16.75	20.75	24.00
WHSV, h ⁻¹	29.42	28.43	28.43	28.43	28.43	29.03	63.62
Cont.time, h	0.0340	0.0352	0.0352	0.0352	0.0352	0.0344	0.0157
Conv. C2	0.718	0.511	0.495	0.475	0.463	0.456	0.255
Conv Benz	2.473	1.510	1.433	1.372	1.332	1.338	0.396
S1(E+B=E)	17.06	16.50	16.59	16.29	16.00	15.96	8.65
S2(B=EB)	94.53	97.88	98.20	98.30	98.34	98.33	100.00
S3(C2=)	26.79	33.45	33.55	33.84	34.04	34.50	40.11
S4 (H2)	54.25	49.23	49.16	49.18	49.28	48.86	50.48
S5 (DEBs)	0.64	0.61	0.55	0.55	0.57	0.58	0.00
S6 (TEB)	1.48	0.00	0.00	0.00	0.00	0.00	0.00
S7 (S2+S5)	96.65	98.50	98.76	98.84	98.91	98.91	100.00
Yield Et-Ben	2.338	1.478	1.407	1.349	1.310	1.316	0.396
H2	0.7378	0.4391	0.4232	0.4073	0.3988	0.3879	0.2276
C1	0.0043	0.0000	0.0000	0.0000	0.0000	0.0000	0.0000
C2	88.8284	89.2361	89.0665	89.2444	89.3745	89.6410	89.6861
C2=	0.3643	0.2984	0.2889	0.2803	0.2754	0.2739	0.1808
C3	0.0035	0.0000	0.0000	0.0000	0.0000	0.0000	0.0000
C3=	0.0018	0.0008	0.0000	0.0000	0.0000	0.0000	0.0000
i-C4	0.0000	0.0000	0.0000	0.0000	0.0000	0.0000	0.0000
n-C4	0.0000	0.0000	0.0000	0.0000	0.0000	0.0000	0.0000
trans -C4=	0.0000	0.0000	0.0000	0.0000	0.0000	0.0000	0.0000
1-C4=	0.0000	0.0000	0.0000	0.0000	0.0000	0.0000	0.0000
iso-C4=	0.0000	0.0000	0.0000	0.0000	0.0000	0.0000	0.0000
cis-C4=	0.0000	0.0000	0.0000	0.0000	0.0000	0.0000	0.0000
C5	0.0000	0.0000	0.0000	0.0000	0.0000	0.0000	0.0000
16.0520	0.0029	0.0033	0.0034	0.0033	0.0033	0.0033	0.0034
Benzene	9.8116	9.8720	10.0725	9.9275	9.8163	9.5650	9.8631
Toluene	0.0024	0.0003	0.0000	0.0000	0.0000	0.0000	0.0000
Et-Benzene	0.2321	0.1472	0.1429	0.1349	0.1294	0.1267	0.0390
m/p Xylene	0.0000	0.0000	0.0000	0.0000	0.0000	0.0000	0.0000
o-Xylene	0.0000	0.0000	0.0000	0.0000	0.0000	0.0000	0.0000
iPB	0.0055	0.0020	0.0018	0.0016	0.0014	0.0014	0.0000
PB	0.0000	0.0000	0.0000	0.0000	0.0000	0.0000	0.0000
Et-Toluene	0.0004	0.0000	0.0000	0.0000	0.0000	0.0000	0.0000
A	0.0000	0.0000	0.0000	0.0000	0.0000	0.0000	0.0000
B	0.0000	0.0000	0.0000	0.0000	0.0000	0.0000	0.0000
1,3-DEB	0.0016	0.0009	0.0008	0.0007	0.0008	0.0007	0.0000
1,4-DEB	0.0000	0.0000	0.0000	0.0000	0.0000	0.0000	0.0000
1,2-DEB	0.0000	0.0000	0.0000	0.0000	0.0000	0.0000	0.0000
TEB	0.0036	0.0000	0.0000	0.0000	0.0000	0.0000	0.0000
SUM DEB	0.0016	0.0009	0.0008	0.0007	0.0008	0.0007	0.0000
SUM Xyl	0.0000	0.0000	0.0000	0.0000	0.0000	0.0000	0.0000
Total	100.0000	100.0000	100.0000	100.0000	100.0000	100.0000	100.0000

Table: Mole%

Date: 29/05/06

Conversion of ethane-benzene over 1%Pt/HZSM5(80)-05 catalyst at 370°C.

Feed: 90mol% ethane, 10mol% Benzene

Comments: TOS, cat. weight = 0.2003g

Feed flowrate = Ethane 16 ml/min

32 ml/min

Experiment	121-ETH	122-ETH	122-ETH0	122-ETH0	122-ETH0	123-ETH	124-ETH
Temper., °C	369	370	370	370	370	369	369
Tsat, oC	20.0	20.0	20.0	20.0	20.0	20.0	20.0
TOS, h	0.20	4.00	8.25	12.50	16.75	20.75	24.00
WHSV, h ⁻¹	7.14	7.19	7.19	7.19	7.19	7.34	14.88
Cont.time,h	0.1401	0.1391	0.1391	0.1391	0.1391	0.1362	0.0672
Conv. C2	0.990	1.164	1.124	1.086	1.153	1.143	0.912
Conv Benz	5.081	7.212	7.764	7.977	7.160	7.312	4.705
S1(E+B=E)	22.65	30.31	30.51	29.84	31.77	31.80	25.00
S2(B=EB)	89.45	91.03	91.43	91.78	92.22	92.42	93.35
S3(C2=)	11.12	13.87	15.18	15.97	14.60	14.87	23.03
S4 (H2)	61.66	51.87	50.56	50.66	50.19	49.97	49.68
S5 (DEBs)	1.22	1.94	2.33	2.22	2.26	2.19	1.62
S6 (TEB)	3.89	2.56	1.57	1.28	0.99	0.90	0.25
S7 (S2+S5)	94.56	95.53	95.33	95.28	95.47	95.50	95.22
Yield Et-Be	4.545	6.566	7.099	7.321	6.603	6.757	4.392
H2	1.2783	1.0624	0.9981	0.9794	1.0048	0.9929	0.7967
C1	0.0112	0.0021	0.0016	0.0016	0.0014	0.0013	0.0006
C2	87.8655	88.9916	90.0641	90.6999	88.9233	89.2233	89.6096
C2=	0.2306	0.2840	0.2997	0.3088	0.2923	0.2955	0.3693
C3	0.0233	0.0137	0.0122	0.0113	0.0099	0.0098	0.0035
C3=	0.0014	0.0013	0.0013	0.0013	0.0012	0.0013	0.0012
i-C4	0.0009	0.0004	0.0003	0.0003	0.0003	0.0002	0.0002
n-C4	0.0021	0.0011	0.0010	0.0010	0.0008	0.0008	0.0005
trans -C4=	0.0000	0.0000	0.0000	0.0000	0.0000	0.0000	0.0000
1-C4=	0.0000	0.0000	0.0000	0.0000	0.0000	0.0000	0.0000
iso-C4=	0.0000	0.0000	0.0000	0.0000	0.0000	0.0000	0.0000
cis-C4=	0.0000	0.0000	0.0000	0.0000	0.0000	0.0000	0.0000
C5	0.0000	0.0000	0.0000	0.0000	0.0000	0.0000	0.0000
16.1470	0.0006	0.0012	0.0012	0.0011	0.0015	0.0015	0.0023
Benzene	10.0613	8.9603	7.9620	7.3670	9.0748	8.7898	8.7868
Toluene	0.0136	0.0048	0.0039	0.0033	0.0033	0.0032	0.0015
Et-Benzene	0.4696	0.6209	0.6021	0.5768	0.6360	0.6318	0.4009
m/p Xylene	0.0000	0.0000	0.0000	0.0000	0.0000	0.0000	0.0000
o-Xylene	0.0000	0.0000	0.0000	0.0000	0.0000	0.0000	0.0000
iPB	0.0114	0.0221	0.0227	0.0224	0.0240	0.0240	0.0170
PB	0.0000	0.0000	0.0000	0.0000	0.0000	0.0000	0.0000
Et-Toluene	0.0030	0.0028	0.0030	0.0028	0.0028	0.0025	0.0013
A	0.0000	0.0000	0.0000	0.0000	0.0000	0.0000	0.0000
B	0.0006	0.0007	0.0012	0.0011	0.0011	0.0011	0.0007
1,3-DEB	0.0037	0.0085	0.0093	0.0087	0.0094	0.0092	0.0044
1,4-DEB	0.0022	0.0042	0.0055	0.0048	0.0057	0.0053	0.0025
1,2-DEB	0.0005	0.0006	0.0004	0.0004	0.0004	0.0004	0.0000
TEB	0.0204	0.0175	0.0103	0.0080	0.0068	0.0061	0.0011
SUM DEB	0.0064	0.0132	0.0153	0.0139	0.0156	0.0149	0.0070
SUM Xyl	0.0000	0.0000	0.0000	0.0000	0.0000	0.0000	0.0000
Total	100.0000	100.0000	100.0000	100.0000	100.0000	100.0000	100.0000

Table: Mole%

Date: 29/05/06

Conversion of ethane-benzene over 1%Pt/HZSM5(80)-05 catalyst at 370°C.

Feed: 90mol% ethane, 10mol% Benzene

Comments: TOS, cat. weight = 0.2003g

Feed flowrate = Ethane 16 ml/min

8 ml/min

Experiment	125-ETH	125-ETH0	125-ETH0	125-ETH0	126-ETH	127-ETH
Temper., °C	369	369	369	369	369	370
Tsat, oC	20.0	20.0	20.0	20.0	19.0	19.0
TOS, h	28.00	32.25	36.50	40.75	44.75	48.00
WHSV, h ⁻¹	7.19	7.19	7.19	7.19	7.29	3.54
Cont.time, h	0.1391	0.1391	0.1391	0.1391	0.1372	0.2825
Conv. C2	1.128	1.137	1.065	1.150	1.116	1.346
Conv Benz	7.168	7.299	7.773	7.029	7.377	9.964
S1(E+B=E)	31.76	31.75	30.54	32.44	31.80	35.52
S2(B=EB)	92.99	92.71	92.58	93.00	92.88	92.99
S3(C2=)	15.20	15.18	16.89	14.89	15.74	10.32
S4 (H2)	49.94	49.87	49.37	49.62	49.41	50.44
S5 (DEBs)	2.13	2.27	2.34	2.18	2.31	2.26
S6 (TEB)	0.50	0.60	0.48	0.46	0.42	0.45
S7 (S2+S5)	95.62	95.58	95.40	95.64	95.61	95.69
Yield Et-Be	6.665	6.766	7.196	6.537	6.851	9.265
H2	0.9843	0.9885	0.9238	0.9863	0.9585	1.1977
C1	0.0011	0.0012	0.0012	0.0000	0.0000	0.0025
C2	89.2022	89.2828	90.7102	88.7304	89.6161	89.3278
C2=	0.2996	0.3009	0.3161	0.2960	0.3053	0.2451
C3	0.0089	0.0088	0.0089	0.0082	0.0082	0.0182
C3=	0.0012	0.0013	0.0013	0.0012	0.0013	0.0014
i-C4	0.0002	0.0003	0.0003	0.0000	0.0000	0.0004
n-C4	0.0008	0.0008	0.0009	0.0008	0.0008	0.0012
trans -C4=	0.0000	0.0000	0.0000	0.0000	0.0000	0.0000
1-C4=	0.0000	0.0000	0.0000	0.0000	0.0000	0.0000
iso-C4=	0.0000	0.0000	0.0000	0.0000	0.0000	0.0000
cis-C4=	0.0000	0.0000	0.0000	0.0000	0.0000	0.0000
C5	0.0000	0.0000	0.0000	0.0000	0.0000	0.0000
16.1470	0.0017	0.0017	0.0014	0.0019	0.0017	0.0010
Benzene	8.8266	8.7351	7.4186	9.2820	8.4438	8.2977
Toluene	0.0029	0.0028	0.0026	0.0028	0.0026	0.0059
Et-Benzene	0.6260	0.6293	0.5715	0.6448	0.6170	0.8433
m/p Xylene	0.0000	0.0000	0.0000	0.0000	0.0000	0.0005
o-Xylene	0.0000	0.0000	0.0000	0.0000	0.0000	0.0001
iPB	0.0237	0.0239	0.0224	0.0244	0.0237	0.0271
PB	0.0000	0.0000	0.0000	0.0000	0.0000	0.0000
Et-Toluene	0.0022	0.0023	0.0026	0.0025	0.0023	0.0042
A	0.0000	0.0000	0.0000	0.0000	0.0000	0.0000
B	0.0007	0.0009	0.0009	0.0006	0.0006	0.0013
1,3-DEB	0.0088	0.0094	0.0089	0.0093	0.0094	0.0129
1,4-DEB	0.0052	0.0056	0.0053	0.0055	0.0056	0.0068
1,2-DEB	0.0004	0.0004	0.0003	0.0003	0.0003	0.0008
TEB	0.0034	0.0041	0.0030	0.0032	0.0028	0.0041
SUM DEB	0.0144	0.0154	0.0145	0.0151	0.0154	0.0205
SUM Xyl	0.0000	0.0000	0.0000	0.0000	0.0000	0.0007
Total	100.0000	100.0000	100.0000	100.0000	100.0000	100.0000

Table: Mole%

Date: 11/06/06

Conversion of ethane-benzene over 1%Pt/HZSM5(80)-05 catalyst at 370°C.

Feed: 90mol% ethane, 10mol% Benzene

Comments: TOS, cat. weight = 0.5002g

Feed flowrate = Ethane 16 ml/min

Experiment	171-ETH	172-ETH	172-ETH0	172-ETH0	172-ETH0	173-ETH
Temper., °C	368	369	369	369	369	368
Tsat, oC	20.0	19.0	19.0	19.0	19.0	21.0
TOS, h	0.20	4.00	8.25	12.50	16.75	21.00
WHSV, h ⁻¹	3.12	3.10	3.10	3.10	3.10	3.12
Cont.time,h	0.3205	0.3226	0.3226	0.3226	0.3226	0.3205
Conv. C2	1.479	1.618	1.573	1.567	1.565	1.568
Conv Benz	8.295	11.258	10.948	11.032	11.137	11.077
S1(E+B=E)	18.97	32.56	34.62	35.41	35.76	36.27
S2(B=EB)	75.00	86.83	89.36	90.33	90.80	91.22
S3(C2=)	4.56	6.32	6.61	6.74	6.84	6.87
S4 (H2)	64.97	54.02	52.83	52.40	52.19	51.85
S5 (DEBs)	1.14	2.05	2.18	2.22	2.28	2.26
S6 (TEB)	13.99	5.94	3.87	3.03	2.55	2.39
S7 (S2+S5)	90.13	94.82	95.42	95.59	95.62	95.86
Yield Et-Be	6.221	9.775	9.784	9.966	10.112	10.105
H2	1.9437	1.5094	1.4403	1.4304	1.4266	1.4154
C1	0.0577	0.0105	0.0070	0.0058	0.0053	0.0052
C2	88.0426	88.6376	88.4403	88.4313	88.4842	88.3728
C2=	0.1364	0.1765	0.1803	0.1839	0.1869	0.1876
C3	0.0874	0.0448	0.0388	0.0357	0.0341	0.0325
C3=	0.0024	0.0016	0.0011	0.0014	0.0014	0.0014
i-C4	0.0030	0.0012	0.0010	0.0008	0.0007	0.0007
n-C4	0.0042	0.0023	0.0019	0.0018	0.0017	0.0017
trans -C4=	0.0000	0.0000	0.0000	0.0000	0.0000	0.0000
1-C4=	0.0000	0.0000	0.0000	0.0000	0.0000	0.0000
iso-C4=	0.0000	0.0000	0.0000	0.0000	0.0000	0.0000
cis-C4=	0.0000	0.0000	0.0000	0.0000	0.0000	0.0000
C5	0.0000	0.0000	0.0000	0.0000	0.0000	0.0000
18.9170	0.0000	0.0000	0.0000	0.0000	0.0000	0.0000
Benzene	8.9656	8.5682	8.8332	8.8390	8.7822	8.8974
Toluene	0.0546	0.0173	0.0136	0.0122	0.0113	0.0107
Et-Benzene	0.5677	0.9098	0.9439	0.9666	0.9776	0.9901
m/p Xylene	0.0015	0.0010	0.0010	0.0009	0.0009	0.0009
o-Xylene	0.0004	0.0003	0.0003	0.0003	0.0003	0.0003
iPB	0.0095	0.0229	0.0243	0.0253	0.0261	0.0266
PB	0.0004	0.0003	0.0003	0.0003	0.0004	0.0004
Et-Toluene	0.0063	0.0087	0.0054	0.0055	0.0052	0.0051
A	0.0000	0.0000	0.0000	0.0000	0.0000	0.0000
B	0.0021	0.0037	0.0034	0.0027	0.0030	0.0009
1,3-DEB	0.0055	0.0137	0.0146	0.0150	0.0156	0.0156
1,4-DEB	0.0025	0.0068	0.0074	0.0076	0.0078	0.0078
1,2-DEB	0.0005	0.0010	0.0011	0.0012	0.0011	0.0010
TEB	0.1059	0.0623	0.0409	0.0324	0.0274	0.0259
SUM DEB	0.0086	0.0215	0.0231	0.0238	0.0245	0.0245
SUM Xyl	0.0019	0.0013	0.0012	0.0012	0.0012	0.0012
Total	100.0000	100.0000	100.0000	100.0000	100.0000	100.0000

Table: Mole%

Conversion of ethane-benzene over 1%Pt/HZSM5(80)-05 catalyst at 370°C.

Feed: 90mol% ethane, 10mol% Benzene

Comments: TOS, cat. weight = 0.5002g

Feed flow: 8 ml/min 32 ml/min

Experiment	174-ETH	175-ETH
Temper., °C	369	368
Tsat, °C	21.0	20.0
TOS, h	24.00	28.00
WHSV, h ⁻¹	1.46	6.34
Cont.time, h	0.6849	0.1577
Conv. C2	1.750	1.253
Conv Benz	12.294	8.754
S1(E+B=E)	35.44	34.28
S2(B=EB)	90.19	91.51
S3(C2=)	4.98	11.42
S4 (H2)	53.44	50.16
S5 (DEBs)	2.08	1.96
S6 (TEB)	2.61	1.64
S7 (S2+S5)	94.88	95.11
Yield Et-Be	11.088	8.011
H2	1.6607	1.0832
C1	0.0102	0.0023
C2	87.9857	89.2544
C2=	0.1548	0.2467
C3	0.0554	0.0159
C3=	0.0017	0.0011
i-C4	0.0013	0.0003
n-C4	0.0022	0.0012
trans -C4=	0.0000	0.0000
1-C4=	0.0000	0.0000
iso-C4=	0.0000	0.0000
cis-C4=	0.0000	0.0000
C5	0.0000	0.0000
18.9170	0.0000	0.0000
Benzene	8.9067	8.5861
Toluene	0.0229	0.0047
Et-Benzene	1.1014	0.7402
m/p Xylene	0.0020	0.0004
o-Xylene	0.0006	0.0001
iPB	0.0245	0.0254
PB	0.0004	0.0003
Et-Toluene	0.0080	0.0022
A	0.0000	0.0000
B	0.0041	0.0065
1,3-DEB	0.0160	0.0108
1,4-DEB	0.0079	0.0046
1,2-DEB	0.0015	0.0005
TEB	0.0319	0.0132
SUM DEB	0.0254	0.0158
SUM Xyl	0.0027	0.0006
Total	100.0000	100.0000

A3.4. Concentrations (mol.%) of products produced over 1PtH-ZSM-5(80) catalyst at 410°C

Table: Mole%

Date: 5/06/06

Conversion of ethane-benzene over 1%Pt/HZSM5(80)-05 catalyst at 410°C.

Feed: 90mol% ethane, 10mol% Benzene

Comments: TOS, cat. weight = 0.0504g

Feed flowrate = Ethane 16 ml/min

32 ml/min

Experiment	141-ETH	142-ETH	142-ETH0	142-ETH0	142-ETH0	143-ETH	144-ETH
Temper., °C	408	409	409	409	409	408	408
Tsat, oC	20.0	19.0	19.0	19.0	19.0	20.0	20.0
TOS, h	0.20	4.00	8.25	12.50	16.75	20.75	24.00
WHSV, h ⁻¹	28.97	28.50	28.50	28.50	28.50	29.96	62.90
Cont.time,h	0.0345	0.0351	0.0351	0.0351	0.0351	0.0334	0.0159
Conv. C2	1.566	1.299	1.248	1.188	1.159	1.128	0.718
Conv Benz	4.902	3.701	3.464	3.388	3.322	3.065	1.136
S1(E+B=E)	15.60	15.42	15.38	14.67	14.15	14.80	8.33
S2(B=EB)	91.41	95.72	96.19	96.62	96.47	96.58	98.64
S3(C2=)	29.13	35.10	35.18	36.16	36.60	35.85	42.24
S4 (H2)	52.80	48.48	48.61	48.45	48.52	48.60	49.06
S5 (DEBs)	1.31	1.22	1.13	0.89	1.10	1.17	0.00
S6 (TEB)	1.41	0.00	0.00	0.00	0.00	0.00	0.00
S7 (S2+S5)	94.13	96.93	97.31	97.51	97.57	97.75	98.64
Yield Et-Be	4.482	3.542	3.332	3.274	3.205	2.960	1.121
H2	1.5116	1.0873	1.0489	1.0021	0.9828	0.9500	0.6191
C1	0.0098	0.0008	0.0000	0.0000	0.0000	0.0000	0.0000
C2	87.5193	88.2840	88.1560	88.9135	89.2584	88.4954	89.4134
C2=	0.8340	0.7871	0.7590	0.7479	0.7415	0.7007	0.5330
C3	0.0087	0.0006	0.0000	0.0000	0.0000	0.0000	0.0000
C3=	0.0067	0.0022	0.0016	0.0013	0.0014	0.0013	0.0000
i-C4	0.0000	0.0000	0.0000	0.0000	0.0000	0.0000	0.0000
n-C4	0.0009	0.0004	0.0000	0.0000	0.0000	0.0000	0.0000
trans -C4=	0.0000	0.0000	0.0000	0.0000	0.0000	0.0000	0.0000
1-C4=	0.0000	0.0000	0.0000	0.0000	0.0000	0.0000	0.0000
iso-C4=	0.0000	0.0000	0.0000	0.0000	0.0000	0.0000	0.0000
cis-C4=	0.0000	0.0000	0.0000	0.0000	0.0000	0.0000	0.0000
C5	0.0000	0.0000	0.0000	0.0000	0.0000	0.0000	0.0000
16.0310	0.0026	0.0031	0.0032	0.0030	0.0029	0.0032	0.0032
Benzene	9.6177	9.4734	9.6864	9.0184	8.7160	9.5500	9.3247
Toluene	0.0054	0.0009	0.0007	0.0005	0.0005	0.0004	0.0000
Et-Benzene	0.4466	0.3457	0.3318	0.3034	0.2867	0.2893	0.1051
m/p Xylene	0.0000	0.0000	0.0000	0.0000	0.0000	0.0000	0.0000
o-Xylene	0.0000	0.0000	0.0000	0.0000	0.0000	0.0000	0.0000
iPB	0.0201	0.0094	0.0081	0.0069	0.0063	0.0059	0.0014
PB	0.0004	0.0001	0.0000	0.0000	0.0000	0.0000	0.0000
Et-Toluene	0.0023	0.0007	0.0005	0.0004	0.0004	0.0004	0.0000
A	0.0000	0.0000	0.0000	0.0000	0.0000	0.0000	0.0000
B	0.0005	0.0000	0.0000	0.0000	0.0000	0.0000	0.0000
1,3-DEB	0.0041	0.0028	0.0021	0.0015	0.0017	0.0020	0.0000
1,4-DEB	0.0023	0.0016	0.0017	0.0013	0.0015	0.0015	0.0000
1,2-DEB	0.0000	0.0000	0.0000	0.0000	0.0000	0.0000	0.0000
TEB	0.0069	0.0000	0.0000	0.0000	0.0000	0.0000	0.0000
SUM DEB	0.0064	0.0044	0.0039	0.0028	0.0033	0.0035	0.0000
SUM Xyl	0.0000	0.0000	0.0000	0.0000	0.0000	0.0000	0.0000
Total	100.0000	100.0000	100.0000	100.0000	100.0000	100.0000	100.0000

Table: Mole%

Date: 26/05/06

Conversion of ethane-benzene over 1%Pt/HZSM5(80)-05 catalyst at 410°C.

Feed: 90mol% ethane, 10mol% Benzene

Comments: TOS, cat. weight = 0.2002 g

Feed flowrate = Ethane 16 ml/min

8 ml/min

Experimert	116-ETH0	116-ETH0	116-ETH0	117-ETH	118-ETH
Temper., °C	408	408	408	409	409
Tsat, °C	19.5	19.5	19.5	20.0	20.0
TOS, h	33.00	37.25	41.50	45.00	48.00
WHSV, h ⁻¹	7.59	7.59	7.59	7.74	3.60
Cont.time, h	0.1318	0.1318	0.1318	0.1292	0.2778
Conv. C2	2.077	2.045	2.050	2.070	2.336
Conv Benz	11.689	11.827	12.157	12.002	13.264
S1(E+B=EB)	25.40	24.93	24.50	25.22	27.60
S2(B=EB)	88.99	88.75	88.63	88.92	88.69
S3(C2=)	20.34	20.99	20.91	20.94	15.20
S4 (H2)	50.16	49.97	50.54	49.81	52.14
S5 (DEBs)	2.42	2.49	2.55	2.50	2.24
S6 (TEB)	0.24	0.38	0.34	0.32	0.40
S7 (S2+S5)	91.64	91.62	91.52	91.75	91.32
Yield Et-Bz	10.401	10.496	10.774	10.673	11.764
H2	1.8184	1.7832	1.8298	1.7950	2.1619
C1	0.0044	0.0042	0.0042	0.0041	0.0078
C2	88.4609	88.8601	89.0523	88.8065	87.3041
C2=	0.7373	0.7491	0.7570	0.7548	0.6304
C3	0.0211	0.0204	0.0197	0.0188	0.0445
C3=	0.0047	0.0046	0.0046	0.0045	0.0062
i-C4	0.0005	0.0005	0.0005	0.0005	0.0010
n-C4	0.0018	0.0017	0.0017	0.0017	0.0024
trans -C4=	0.0000	0.0000	0.0000	0.0000	0.0000
1-C4=	0.0000	0.0000	0.0000	0.0000	0.0000
iso-C4=	0.0007	0.0007	0.0008	0.0007	0.0008
cis-C4=	0.0000	0.0000	0.0000	0.0000	0.0000
C5	0.0000	0.0000	0.0000	0.0000	0.0000
16.1290	0.0015	0.0015	0.0014	0.0016	0.0011
Benzene	7.9138	7.5714	7.3270	7.5894	8.5493
Toluene	0.0050	0.0046	0.0045	0.0044	0.0128
Et-Benzene	0.9208	0.8898	0.8873	0.9090	1.1445
m/p Xylene	0.0009	0.0008	0.0008	0.0008	0.0022
o-Xylene	0.0005	0.0005	0.0005	0.0005	0.0007
iPB	0.0696	0.0680	0.0685	0.0692	0.0777
PB	0.0004	0.0004	0.0004	0.0004	0.0006
Et-Toluene	0.0057	0.0056	0.0062	0.0058	0.0101
A	0.0008	0.0008	0.0013	0.0009	0.0010
B	0.0036	0.0033	0.0028	0.0026	0.0069
1,3-DEB	0.0150	0.0150	0.0152	0.0153	0.0177
1,4-DEB	0.0093	0.0093	0.0097	0.0097	0.0101
1,2-DEB	0.0007	0.0007	0.0006	0.0005	0.0011
TEB	0.0025	0.0038	0.0034	0.0033	0.0052
SUM DEB	0.0250	0.0250	0.0255	0.0256	0.0288
SUM Xyl	0.0014	0.0013	0.0013	0.0013	0.0029
Total	100.0000	100.0000	100.0000	100.0000	100.0000

Table: Mole%

Date: 14/06/06

Conversion of ethane-benzene over 1%Pt/HZSM5(80)-05 catalyst at 410°C.

Feed: 90mol% ethane, 10mol% Benzene

Comments: TOS, cat. weight = 0.5000 g

Feed flowrate = Ethane 16 ml/min

Experiment	181-ETH	182-ETH	182-ETH0	182-ETH0	182-ETH0	183-ETH
Temper., °C	407	408	408	408	408	408
Tsat, oC	20.0	20.0	20.0	20.0	20.0	20.0
TOS, h	0.20	4.00	8.25	12.50	16.75	20.50
WHSV, h ⁻¹	3.06	3.04	3.04	3.04	3.04	3.06
Cont.time,h	0.3268	0.3289	0.3289	0.3289	0.3289	0.3268
Conv. C2	2.132	2.574	2.524	2.514	2.520	2.589
Conv Benz	10.264	14.546	14.537	14.761	15.000	15.412
S1(E+B=E)	12.89	23.32	25.18	25.73	26.21	26.52
S2(B=EB)	72.45	79.66	82.51	83.32	83.94	82.46
S3(C2=)	7.51	10.71	11.52	11.84	12.14	12.36
S4 (H2)	67.93	56.39	54.45	53.96	53.50	52.43
S5 (DEBs)	1.00	1.78	2.25	2.28	2.35	2.42
S6 (TEB)	10.02	7.45	4.50	3.74	3.19	4.24
S7 (S2+S5)	83.47	88.89	89.26	89.34	89.49	89.11
Yield Et-Be	7.436	11.587	11.995	12.298	12.592	12.708
H2	3.3368	2.5576	2.4067	2.3763	2.3589	2.2963
C1	0.1239	0.0316	0.0307	0.0287	0.0271	0.0260
C2	87.0366	87.3050	87.3842	87.5026	87.5737	87.6298
C2=	0.3688	0.4856	0.5091	0.5216	0.5352	0.5413
C3	0.1845	0.1166	0.1082	0.1010	0.0958	0.0917
C3=	0.0106	0.0094	0.0090	0.0089	0.0086	0.0085
i-C4	0.0047	0.0020	0.0021	0.0019	0.0019	0.0018
n-C4	0.0066	0.0038	0.0038	0.0037	0.0037	0.0037
trans -C4=	0.0008	0.0006	0.0006	0.0006	0.0006	0.0006
1-C4=	0.0000	0.0000	0.0000	0.0000	0.0000	0.0000
iso-C4=	0.0013	0.0010	0.0010	0.0010	0.0010	0.0011
cis-C4=	0.0000	0.0000	0.0000	0.0000	0.0000	0.0000
C5	0.0000	0.0000	0.0000	0.0000	0.0000	0.0000
18.9170	0.0000	0.0000	0.0000	0.0000	0.0000	0.0000
Benzene	8.0516	8.1593	8.1958	8.0934	8.0170	7.9907
Toluene	0.0989	0.0412	0.0363	0.0326	0.0300	0.0281
Et-Benzene	0.6331	1.0576	1.1129	1.1333	1.1556	1.1615
m/p Xylene	0.0044	0.0041	0.0039	0.0038	0.0035	0.0035
o-Xylene	0.0012	0.0012	0.0011	0.0011	0.0010	0.0010
iPB	0.0237	0.0587	0.0658	0.0694	0.0729	0.0744
PB	0.0006	0.0005	0.0004	0.0004	0.0005	0.0005
Et-Toluene	0.0113	0.0225	0.0181	0.0176	0.0175	0.0200
A	0.0009	0.0015	0.0007	0.0009	0.0010	0.0009
B	0.0034	0.0177	0.0185	0.0194	0.0182	0.0249
1,3-DEB	0.0055	0.0157	0.0184	0.0191	0.0201	0.0211
1,4-DEB	0.0027	0.0062	0.0102	0.0103	0.0105	0.0112
1,2-DEB	0.0006	0.0018	0.0017	0.0016	0.0017	0.0017
TEB	0.0876	0.0989	0.0607	0.0508	0.0439	0.0597
SUM DEB	0.0088	0.0237	0.0303	0.0311	0.0324	0.0341
SUM Xyl	0.0056	0.0053	0.0051	0.0049	0.0045	0.0045
Total	100.0000	100.0000	100.0000	100.0000	100.0000	100.0000

Table: Mole%

Conversion of ethane-benzene over 1%Pt/HZSM5(80)-05 catalyst at 410°C.

Feed: 90mol% ethane, 10mol% Benzene

Comments: TOS, cat. weight = 0.5000 g

Feed flow: 8 ml/min 32 ml/min

Experiment	184-ETH	185-ETH
Temper., °C	408	408
Tsat, oC	20.0	20.0
TOS, h	24.00	28.00
WHSV, h ⁻¹	1.46	6.34
Cont.time, h	0.6849	0.1577
Conv. C2	2.591	2.376
Conv Benz	14.829	13.630
S1(E+B=E)	23.48	27.69
S2(B=EB)	80.43	86.41
S3(C2=)	9.99	15.56
S4 (H2)	56.05	50.85
S5 (DEBs)	2.09	2.54
S6 (TEB)	3.70	1.82
S7 (S2+S5)	86.22	90.77
Yield Et-Be	11.927	11.778
H2	2.6261	2.0603
C1	0.0487	0.0111
C2	87.2100	87.5512
C2=	0.4682	0.6304
C3	0.1539	0.0411
C3=	0.0116	0.0052
i-C4	0.0028	0.0008
n-C4	0.0045	0.0026
trans -C4=	0.0006	0.0000
1-C4=	0.0000	0.0000
iso-C4=	0.0011	0.0009
cis-C4=	0.0000	0.0000
C5	0.0000	0.0000
16.2020	0.0000	0.0010
Benzene	8.1045	8.3971
Toluene	0.0600	0.0104
Et-Benzene	1.1003	1.1218
m/p Xylene	0.0073	0.0014
o-Xylene	0.0023	0.0004
iPB	0.0609	0.0836
PB	0.0007	0.0004
Et-Toluene	0.0287	0.0122
A	0.0013	0.0011
B	0.0272	0.0103
1,3-DEB	0.0177	0.0203
1,4-DEB	0.0090	0.0117
1,2-DEB	0.0018	0.0009
TEB	0.0507	0.0237
SUM DEB	0.0285	0.0330
SUM Xyl	0.0096	0.0019
Total	100.0000	100.0000

A3.5. Concentrations (mol.%) of products produced over 1PtH-ZSM-5(80) catalyst at 450°C

Table: Mole%

Date: 18/05/06

Conversion of ethane-benzene over 1%Pt/HZSM5(80)-05 catalyst at 450°C.

Feed: 90mol% ethane, 10mol% Benzene

Comments: TOS, cat. weight = 0.0505g

Feed flowrate = Ethane 16 ml/min

Experiment	91-ETH	92-ETH	92-ETH00	92-ETH00	92-ETH00	93-ETH	94-ETH
Temper., °C	448	449	449	449	449	449	449
Tsat, oC	20.0	20.5	20.5	20.5	20.5	20.0	20.0
TOS, h	0.20	4.00	8.25	12.50	16.75	20.67	24.02
WHSV, h ⁻¹	30.30	30.10	30.10	30.10	30.10	30.30	30.69
Cont.time,h	0.0330	0.0332	0.0332	0.0332	0.0332	0.0330	0.0326
Conv. C2	2.991	2.931	2.876	2.813	2.779	2.764	2.746
Conv Benz	7.386	6.571	6.465	6.474	6.325	6.130	6.131
S1(E+B=E)	11.29	11.64	11.33	10.93	10.83	11.24	11.35
S2(B=EB)	84.91	89.65	90.89	91.51	92.09	92.65	92.76
S3(C2=)	33.22	36.96	37.55	38.65	38.62	38.33	38.02
S4 (H2)	52.51	49.65	49.63	49.09	49.32	49.25	49.47
S5 (DEBs)	1.57	1.78	1.67	1.69	1.63	1.55	1.66
S6 (TEB)	2.57	0.22	0.00	0.00	0.00	0.00	0.00
S7 (S2+S5)	89.05	91.65	92.55	93.20	93.72	94.20	94.42
Yield Et-Be	6.272	5.891	5.876	5.924	5.825	5.680	5.687
H2	2.8072	2.5099	2.4781	2.3963	2.3897	2.3591	2.3621
C1	0.0166	0.0043	0.0035	0.0031	0.0027	0.0024	0.0022
C2	85.5472	85.5177	85.9179	86.6231	86.6430	86.2327	86.2031
C2=	1.7761	1.8685	1.8748	1.8866	1.8713	1.8361	1.8155
C3	0.0161	0.0048	0.0037	0.0030	0.0025	0.0022	0.0021
C3=	0.0141	0.0063	0.0055	0.0051	0.0047	0.0045	0.0044
i-C4	0.0000	0.0000	0.0000	0.0000	0.0000	0.0000	0.0000
n-C4	0.0016	0.0011	0.0010	0.0010	0.0009	0.0009	0.0009
trans -C4=	0.0000	0.0000	0.0000	0.0000	0.0000	0.0000	0.0000
1-C4=	0.0000	0.0000	0.0000	0.0000	0.0000	0.0000	0.0000
iso-C4=	0.0013	0.0009	0.0009	0.0009	0.0008	0.0008	0.0008
cis-C4=	0.0000	0.0000	0.0000	0.0000	0.0000	0.0000	0.0000
C5	0.0000	0.0000	0.0000	0.0000	0.0000	0.0000	0.0000
16.1860	0.0021	0.0027	0.0027	0.0025	0.0026	0.0028	0.0028
Benzene	9.1067	9.4276	9.0894	8.4957	8.5121	8.9773	9.0221
Toluene	0.0084	0.0019	0.0014	0.0012	0.0010	0.0010	0.0010
Et-Benzene	0.6037	0.5884	0.5659	0.5333	0.5246	0.5384	0.5417
m/p Xylene	0.0008	0.0004	0.0004	0.0004	0.0004	0.0004	0.0004
o-Xylene	0.0002	0.0001	0.0001	0.0001	0.0001	0.0001	0.0001
iPB	0.0579	0.0484	0.0412	0.0354	0.0318	0.0299	0.0288
PB	0.0000	0.0000	0.0000	0.0000	0.0000	0.0000	0.0000
Et-Toluene	0.0044	0.0020	0.0015	0.0013	0.0012	0.0011	0.0011
A	0.0021	0.0006	0.0010	0.0004	0.0005	0.0005	0.0005
B	0.0040	0.0013	0.0007	0.0007	0.0007	0.0007	0.0007
1,3-DEB	0.0068	0.0062	0.0056	0.0053	0.0050	0.0049	0.0052
1,4-DEB	0.0044	0.0055	0.0048	0.0046	0.0043	0.0041	0.0045
1,2-DEB	0.0000	0.0000	0.0000	0.0000	0.0000	0.0000	0.0000
1,3,5-TEB	0.0183	0.0014	0.0000	0.0000	0.0000	0.0000	0.0000
1,2,4-TEB	0.0000	0.0000	0.0000	0.0000	0.0000	0.0000	0.0000
SUM DEB	0.0112	0.0117	0.0104	0.0098	0.0093	0.0090	0.0097
SUM Xyl	0.0010	0.0005	0.0005	0.0005	0.0005	0.0005	0.0005
Total	100.0000	100.0000	100.0000	100.0000	100.0000	100.0000	100.0000

Table: Mole%

Date: 7/2/06

Conversion of ethane-benzene over 1%Pt/HZSM5(80)-05 catalyst at 450°C.

Feed: 90mol% ethane, 10mol% Benzene

Comments: TOS, cat. weight = 0.0701g

Feed flowrate = Ethane 16 ml/min 32 ml/min

Experiment	51-ETH	52-ETH	53-ETH	54-ETH
Temper., °C	447	447	447	447
Tsat, °C	20.0	20.0	20.5	20.5
TOS, h	0.20	4.00	20.60	24.10
WHSV, h ⁻¹	19.69	19.83	20.83	43.08
Cont.time, h	0.0508	0.0504	0.0480	0.0232
Conv. C2	3.245	3.289	3.202	2.730
Conv Benz	10.016	9.877	9.148	5.371
S1(E+B=E)	13.42	14.23	14.43	10.11
S2(B=EB)	80.36	83.45	87.69	92.21
S3(C2=)	29.03	31.48	33.57	40.14
S4 (H2)	52.67	50.47	49.41	48.61
S5 (DEBs)	1.76	2.32	2.06	1.49
S6 (TEB)	4.09	0.47	0.10	0.00
S7 (S2+S5)	86.21	86.24	89.85	93.70
Yield Et-Be	8.048	8.242	8.023	4.953
H2	3.0012	2.8586	2.7051	2.2753
C1	0.0301	0.0166	0.0074	0.0032
C2	85.4975	85.3970	85.4822	86.2046
C2=	1.6543	1.7830	1.8380	1.8789
C3	0.0366	0.0218	0.0097	0.0021
C3=	0.0182	0.0113	0.0078	0.0034
i-C4	0.0000	0.0000	0.0000	0.0000
n-C4	0.0022	0.0021	0.0015	0.0007
trans -C4=	0.0009	0.0010	0.0008	0.0005
1-C4=	0.0000	0.0000	0.0000	0.0000
iso-C4=	0.0016	0.0017	0.0013	0.0008
cis-C4=	0.0000	0.0000	0.0000	0.0000
C5	0.0000	0.0000	0.0000	0.0000
16.0560	0.0014	0.0020	0.0025	0.0028
Benzene	8.8046	8.9386	9.0429	9.1146
Toluene	0.0158	0.0068	0.0030	0.0010
Et-Benzene	0.7646	0.8063	0.7900	0.4731
m/p Xylene	0.0016	0.0012	0.0009	0.0002
o-Xylene	0.0005	0.0004	0.0003	0.0001
iPB	0.0897	0.1062	0.0784	0.0299
PB	0.0005	0.0003	0.0002	0.0000
Et-Toluene	0.0095	0.0081	0.0043	0.0008
A	0.0032	0.0031	0.0011	0.0004
B	0.0104	0.0069	0.0033	0.0000
1,3-DEB	0.0103	0.0117	0.0101	0.0038
1,4-DEB	0.0058	0.0102	0.0081	0.0038
1,2-DEB	0.0006	0.0005	0.0004	0.0000
1,3,5-TEB	0.0389	0.0045	0.0009	0.0000
1,2,4-TEB	0.0000	0.0000	0.0000	0.0000
SUM DEB	0.0168	0.0224	0.0185	0.0076
SUM Xyl	0.0021	0.0016	0.0011	0.0003
Total	100.0000	100.0000	100.0000	100.0000

Table: Mole%

Date: 24/01/06

Conversion of ethane-benzene over 1%Pt/HZSM5(80)-05 catalyst at 450°C.

Feed: 90mol% ethane, 10mol% Benzene

Comments: TOS, cat. weight = 0.1001g

Feed flowrate = Ethane 16 ml/min

Experiment	31-ETH	32-ETH	33-ETH	34-ETH	35-ETH	36-ETH	37-ETH
Temper., °C	447	447	447	447	447	447	447
Tsat, oC	20.0	20.0	21.0	20.0	19.0	19.5	19.0
TOS, h	0.20	4.00	20.85	24.35	28.10	44.87	48.25
WHSV, h ⁻¹	14.69	15.49	15.49	15.08	15.18	15.48	15.28
Cont.time,h	0.0681	0.0646	0.0646	0.0663	0.0659	0.0646	0.0654
Conv. C2	3.264	3.382	3.295	3.270	3.284	3.192	3.250
Conv Benz	10.839	11.790	11.596	11.535	11.121	10.380	10.597
S1(E+B=E)	13.56	15.51	15.21	14.87	15.57	15.29	16.04
S2(B=EB)	80.24	82.49	86.73	86.56	87.52	89.67	89.56
S3(C2=)	26.75	30.12	32.52	32.54	32.26	33.72	32.85
S4 (H2)	54.72	49.81	49.19	49.58	49.30	48.59	48.69
S5 (DEBs)	1.78	2.40	2.23	2.54	2.28	2.05	2.19
S6 (TEB)	4.32	0.88	0.18	0.19	0.19	0.09	0.08
S7 (S2+S5)	86.34	85.78	89.14	89.29	89.98	91.81	91.84
Yield Et-Be	8.697	9.726	10.058	9.985	9.733	9.307	9.491
H2	3.2430	2.8718	2.7909	2.8105	2.7811	2.6519	2.6953
C1	0.0279	0.0208	0.0114	0.0092	0.0079	0.0122	0.0076
C2	85.5750	85.9980	86.6520	86.7683	86.2433	86.4178	86.0126
C2=	1.5852	1.7364	1.8451	1.8447	1.8199	1.8405	1.8184
C3	0.0437	0.0306	0.0140	0.0135	0.0120	0.0076	0.0077
C3=	0.0181	0.0137	0.0099	0.0098	0.0095	0.0082	0.0083
i-C4	0.0000	0.0000	0.0000	0.0000	0.0000	0.0000	0.0000
n-C4	0.0026	0.0026	0.0021	0.0021	0.0019	0.0017	0.0017
trans -C4=	0.0011	0.0013	0.0010	0.0010	0.0009	0.0008	0.0009
1-C4=	0.0000	0.0000	0.0000	0.0000	0.0000	0.0000	0.0000
iso-C4=	0.0018	0.0019	0.0016	0.0016	0.0015	0.0014	0.0014
cis-C4=	0.0007	0.0008	0.0007	0.0007	0.0006	0.0006	0.0006
C5	0.0000	0.0000	0.0000	0.0000	0.0000	0.0000	0.0000
16.0960	0.0011	0.0016	0.0020	0.0019	0.0021	0.0023	0.0023
Benzene	8.4982	8.2370	7.6744	7.5629	8.1155	8.1240	8.4522
Toluene	0.0185	0.0095	0.0041	0.0038	0.0035	0.0025	0.0026
Et-Benzene	0.8036	0.8939	0.8629	0.8429	0.8783	0.8347	0.8876
m/p Xylene	0.0020	0.0017	0.0012	0.0011	0.0011	0.0009	0.0010
o-Xylene	0.0006	0.0005	0.0004	0.0003	0.0003	0.0003	0.0003
iPB	0.0893	0.1205	0.0898	0.0859	0.0842	0.0651	0.0694
PB	0.0004	0.0003	0.0001	0.0000	0.0000	0.0000	0.0000
Et-Toluene	0.0103	0.0107	0.0060	0.0057	0.0049	0.0028	0.0032
A	0.0024	0.0028	0.0015	0.0015	0.0014	0.0008	0.0006
B	0.0134	0.0082	0.0050	0.0059	0.0050	0.0038	0.0038
1,3-DEB	0.0110	0.0140	0.0122	0.0136	0.0130	0.0108	0.0125
1,4-DEB	0.0057	0.0112	0.0094	0.0102	0.0092	0.0077	0.0087
1,2-DEB	0.0011	0.0007	0.0006	0.0009	0.0006	0.0005	0.0006
1,3,5-TEB	0.0432	0.0096	0.0018	0.0019	0.0019	0.0008	0.0008
1,2,4-TEB	0.0000	0.0000	0.0000	0.0000	0.0000	0.0000	0.0000
SUM DEB	0.0179	0.0260	0.0221	0.0247	0.0229	0.0191	0.0217
SUM Xyl	0.0025	0.0021	0.0016	0.0015	0.0015	0.0012	0.0012
Total	100.0000	100.0000	100.0000	100.0000	100.0000	100.0000	100.0000

Table: Mole%

Date: 17/01/06

Conversion of ethane-benzene over 1%Pt/HZSM5(80)-05 catalyst at 450°C.

Feed: 90mol% ethane, 10mol% Benzene

Comments: TOS, cat. weight = 0.2001g

Feed flowrate = Ethane 16 ml/min

Experiment	21-ETH	22-ETH	23-ETH	24-ETH	25-ETH	26-ETH	27-ETH
Temper., °C	448	448	448	449	449	449	449
Tsat, oC	20.5	20.0	21.0	20.5	20.0	20.0	20.0
TOS, h	0.20	4.00	20.67	24.67	28.67	44.70	48.50
WHSV, h ⁻¹	7.35	7.35	7.50	7.40	7.40	7.40	7.45
Cont.time,h	0.1361	0.1361	0.1333	0.1351	0.1351	0.1351	0.1342
Conv. C2	3.597	3.953	3.823	3.725	3.709	3.662	3.651
Conv Benz	12.572	15.215	14.653	14.791	14.834	14.471	14.519
S1(E+B=E)	12.12	15.89	17.73	17.63	17.57	17.66	17.70
S2(B=EB)	73.42	75.42	80.69	81.00	81.29	82.77	83.12
S3(C2=)	19.76	22.94	25.60	25.60	25.76	26.90	26.90
S4 (H2)	58.17	52.31	50.52	50.89	50.99	50.45	50.53
S5 (DEBs)	1.25	2.29	2.28	2.37	2.40	2.47	2.41
S6 (TEB)	6.39	3.28	0.89	0.92	0.84	0.59	0.54
S7 (S2+S5)	81.06	80.99	83.86	84.28	84.53	85.83	86.07
Yield Et-Be	9.231	11.476	11.824	11.980	12.059	11.977	12.067
H2	3.9877	3.4674	3.1887	3.2429	3.2439	3.1549	3.1668
C1	0.1562	0.0865	0.0311	0.0270	0.0242	0.0170	0.0164
C2	84.9626	85.3531	85.4665	85.4992	85.6052	85.7391	85.7542
C2=	1.3547	1.5204	1.6160	1.6310	1.6389	1.6824	1.6857
C3	0.1739	0.1143	0.0588	0.0544	0.0502	0.0381	0.0369
C3=	0.0367	0.0279	0.0187	0.0181	0.0179	0.0160	0.0159
i-C4	0.0028	0.0023	0.0009	0.0008	0.0008	0.0006	0.0006
n-C4	0.0051	0.0056	0.0040	0.0039	0.0038	0.0035	0.0035
trans -C4=	0.0017	0.0020	0.0016	0.0016	0.0015	0.0014	0.0014
1-C4=	0.0007	0.0009	0.0007	0.0008	0.0008	0.0008	0.0008
iso-C4=	0.0028	0.0033	0.0026	0.0026	0.0025	0.0023	0.0023
cis-C4=	0.0011	0.0013	0.0011	0.0010	0.0010	0.0010	0.0010
C5	0.0000	0.0000	0.0000	0.0000	0.0000	0.0000	0.0000
16.1150	0.0000	0.0005	0.0013	0.0014	0.0014	0.0016	0.0016
Benzene	8.1821	8.0182	8.2212	8.1288	8.0326	8.0072	7.9782
Toluene	0.0767	0.0402	0.0165	0.0150	0.0138	0.0105	0.0103
Et-Benzene	0.8310	1.0532	1.1190	1.1231	1.1181	1.1041	1.1094
m/p Xylene	0.0063	0.0050	0.0035	0.0033	0.0032	0.0027	0.0028
o-Xylene	0.0018	0.0013	0.0010	0.0010	0.0009	0.0008	0.0008
iPB	0.0947	0.1545	0.1573	0.1568	0.1538	0.1426	0.1414
PB	0.0007	0.0005	0.0004	0.0004	0.0004	0.0004	0.0000
Et-Toluene	0.0185	0.0251	0.0182	0.0184	0.0184	0.0149	0.0129
A	0.0029	0.0047	0.0041	0.0040	0.0036	0.0029	0.0029
B	0.0128	0.0340	0.0229	0.0191	0.0187	0.0143	0.0148
1,3-DEB	0.0092	0.0174	0.0182	0.0192	0.0195	0.0191	0.0191
1,4-DEB	0.0044	0.0132	0.0124	0.0123	0.0123	0.0127	0.0119
1,2-DEB	0.0005	0.0014	0.0011	0.0013	0.0012	0.0012	0.0011
1,3,5-TEB	0.0723	0.0452	0.0120	0.0124	0.0112	0.0075	0.0069
1,2,4-TEB	0.0000	0.0005	0.0003	0.0003	0.0003	0.0003	0.0003
SUM DEB	0.0142	0.0320	0.0317	0.0328	0.0330	0.0330	0.0322
SUM Xyl	0.0082	0.0063	0.0044	0.0043	0.0041	0.0035	0.0035
Total	100.0000	100.0000	100.0000	100.0000	100.0000	100.0000	100.0000

Table: Mole%

Date: 15/02/06

Conversion of ethane-benzene over 1%Pt/HZSM5(80)-05 catalyst at 450°C.

Feed: 90mol% ethane, 10mol% Benzene

Comments: TOS, cat. weight = 0.5003g

Feed flowrate = Ethane 16 ml/min

24 ml/min

48 ml/min

Experiment	71-ETH	72-ETH	73-ETH	74-ETH	75-ETH	76-ETH	77-ETH
Temper., °C	449	449	449	449	449	449	448
Tsat, oC	20.0	20.0	20.5	20.0	20.0	20.0	20.0
TOS, h	0.20	4.00	20.70	24.52	28.05	44.25	48.33
WHSV, h ⁻¹	3.04	3.06	3.12	4.76	3.06	3.12	9.81
Cont.time, h	0.3289	0.3268	0.3205	0.2101	0.3268	0.3205	0.1019
Conv. C2	3.750	3.984	4.150	3.992	3.940	3.897	3.409
Conv Benz	12.964	16.489	17.409	15.754	16.559	16.466	13.470
S1(E+B=E)	8.16	13.12	17.67	19.55	17.41	17.91	17.94
S2(B=EB)	57.74	65.90	73.14	77.76	75.30	76.65	85.28
S3(C2=)	10.98	16.04	18.29	20.49	19.35	20.32	27.88
S4 (H2)	66.37	57.84	53.46	51.67	53.85	53.32	50.07
S5 (DEBs)	0.84	1.72	2.56	2.46	2.45	2.48	2.26
S6 (TEB)	15.40	8.31	3.37	1.84	1.95	2.03	0.43
S7 (S2+S5)	73.98	75.93	79.06	82.06	79.70	81.17	87.97
Yield Et-Be	7.486	10.865	12.732	12.251	12.469	12.621	11.487
H2	5.3556	4.1581	3.7681	3.4409	3.6912	3.5916	2.9341
C1	0.3124	0.1505	0.0803	0.0444	0.0618	0.0430	0.0116
C2	83.6677	85.1409	84.5939	84.1667	84.9357	85.0638	86.1181
C2=	0.8861	1.1528	1.2894	1.3646	1.3262	1.3690	1.6340
C3	0.3150	0.2389	0.1588	0.0984	0.1428	0.1157	0.0250
C3=	0.0405	0.0404	0.0328	0.0238	0.0312	0.0279	0.0131
i-C4	0.0052	0.0037	0.0025	0.0015	0.0021	0.0017	0.0003
n-C4	0.0077	0.0064	0.0061	0.0049	0.0060	0.0056	0.0029
trans -C4=	0.0016	0.0016	0.0017	0.0015	0.0017	0.0016	0.0011
1-C4=	0.0010	0.0010	0.0011	0.0009	0.0010	0.0011	0.0007
iso-C4=	0.0030	0.0030	0.0032	0.0027	0.0031	0.0031	0.0019
cis-C4=	0.0011	0.0012	0.0012	0.0011	0.0013	0.0012	0.0008
C5	0.0000	0.0000	0.0000	0.0000	0.0000	0.0000	0.0000
16.2000	0.0000	0.0000	0.0000	0.0010	0.0006	0.0009	0.0020
Benzene	8.2627	7.6696	8.3580	9.1739	8.2102	8.2002	8.0220
Toluene	0.1862	0.1004	0.0569	0.0307	0.0485	0.0368	0.0063
Et-Benzene	0.6585	0.9435	1.2454	1.3016	1.1936	1.2062	1.0510
m/p Xylene	0.0145	0.0129	0.0102	0.0061	0.0092	0.0078	0.0018
o-Xylene	0.0043	0.0038	0.0031	0.0017	0.0026	0.0022	0.0006
iPB	0.0539	0.1085	0.1690	0.1790	0.1570	0.1589	0.1232
PB	0.0009	0.0010	0.0009	0.0007	0.0008	0.0007	0.0003
Et-Toluene	0.0228	0.0440	0.0474	0.0321	0.0395	0.0341	0.0062
A	0.0024	0.0050	0.0059	0.0050	0.0048	0.0043	0.0011
B	0.0119	0.0691	0.0631	0.0449	0.0595	0.0515	0.0086
1,3-DEB	0.0058	0.0149	0.0243	0.0239	0.0220	0.0224	0.0163
1,4-DEB	0.0027	0.0076	0.0164	0.0153	0.0141	0.0143	0.0116
1,2-DEB	0.0010	0.0022	0.0028	0.0019	0.0027	0.0024	0.0000
1,3,5-TEB	0.1756	0.1190	0.0563	0.0303	0.0309	0.0311	0.0053
1,2,4-TEB	0.0000	0.0000	0.0010	0.0005	0.0000	0.0009	0.0000
SUM DEB	0.0095	0.0246	0.0436	0.0411	0.0388	0.0391	0.0279
SUM Xyl	0.0187	0.0167	0.0133	0.0078	0.0118	0.0100	0.0024
Total	100.0000	100.0000	100.0000	100.0000	100.0000	100.0000	100.0000

Table: Mole%

Date: 05/06/07

Conversion of ethane-benzene over 1%Pt/HZSM5(80) catalyst at 450oC.

Feed: 90mol% ethane, 10mol% Benzene

Comments: TOS, cat. weight = 0.5001g

Feed flowrate = Ethane 16 ml/min

8 ml/min

Experiment	341-ETH	342-ETH	342-ETH0	343-ETH	344-ETH	344-ETH001
Temper., °C	448	448	448	448	448	448
Tsat, oC	20.0	20.0	20.0	20.0	20.0	20.0
TOS, h	0.20	6.40	12.60	20.50	26.75	33.00
WHSV, h ⁻¹	3.14	3.12	3.12	3.12	1.54	3.12
Cont.time, h	0.3185	0.3205	0.3205	0.3205	0.6494	0.3205
Conv. C2	3.961	4.088	4.025	4.165	4.077	3.963
Conv Benz	11.289	16.625	16.677	18.316	16.849	17.054
S1(E+B=E)	6.28	14.57	15.01	16.60	13.64	17.28
S2(B=EB)	57.81	68.99	69.98	70.41	65.02	73.73
S3(C2=)	10.83	16.36	17.95	18.84	16.06	20.30
S4 (H2)	57.68	55.91	54.79	52.69	55.71	52.21
S5 (DEBs)	0.72	2.01	2.00	2.52	2.11	2.47
S6 (TEB)	5.26	3.96	3.59	2.96	3.74	2.60
S7 (S2+S5)	63.78	74.95	75.58	75.89	70.87	78.80
Yield Et-Be	6.526	11.470	11.672	12.896	10.955	12.575
H2	4.8869	4.0263	3.8174	3.6534	3.9753	3.4705
C1	1.2468	0.1743	0.1430	0.1112	0.1795	0.0794
C2	84.0583	84.7955	85.2059	85.4332	85.0992	85.4925
C2=	0.9173	1.1781	1.2503	1.3066	1.1462	1.3493
C3	0.4078	0.2407	0.2054	0.1744	0.2708	0.1425
C3=	0.0537	0.0423	0.0389	0.0360	0.0460	0.0319
i-C4	0.0085	0.0040	0.0036	0.0029	0.0043	0.0022
n-C4	0.0169	0.0069	0.0068	0.0067	0.0079	0.0062
trans -C4=	0.0039	0.0018	0.0019	0.0019	0.0020	0.0018
1-C4=	0.0019	0.0010	0.0011	0.0012	0.0011	0.0010
iso-C4=	0.0061	0.0033	0.0034	0.0036	0.0037	0.0033
cis-C4=	0.0027	0.0013	0.0013	0.0014	0.0014	0.0013
C5	0.0000	0.0000	0.0000	0.0000	0.0006	0.0000
18.9170	0.0000	0.0000	0.0000	0.0000	0.0000	0.0000
Benzene	7.4693	8.0037	7.8270	7.6326	7.7646	7.8601
Toluene	0.2434	0.0977	0.0747	0.0603	0.1165	0.0451
Et-Benzene	0.5319	1.0491	1.0454	1.1511	0.9736	1.1487
m/p Xylene	0.0135	0.0120	0.0098	0.0096	0.0175	0.0079
o-Xylene	0.0038	0.0037	0.0029	0.0029	0.0054	0.0022
iPB	0.0414	0.1172	0.1242	0.1489	0.1057	0.1469
PB	0.0010	0.0011	0.0008	0.0009	0.0012	0.0007
Et-Toluene	0.0105	0.0369	0.0370	0.0427	0.0508	0.0348
A	0.0103	0.0124	0.0106	0.0112	0.0119	0.0084
B	0.0092	0.0717	0.0774	0.0899	0.1086	0.0720
1,3-DEB	0.0037	0.0168	0.0173	0.0224	0.0167	0.0215
1,4-DEB	0.0029	0.0117	0.0111	0.0163	0.0128	0.0148
1,2-DEB	0.0000	0.0020	0.0015	0.0024	0.0022	0.0022
1,3,5-TEB	0.0484	0.0589	0.0537	0.0466	0.0550	0.0392
1,2,4-TEB	0.0000	0.0013	0.0000	0.0019	0.0010	0.0013
C	0.0000	0.0281	0.0274	0.0279	0.0187	0.0121
SUM DEB	0.0066	0.0305	0.0299	0.0412	0.0316	0.0385
SUM Xyl	0.0173	0.0157	0.0127	0.0124	0.0228	0.0102
Total	100.0000	100.0000	100.0000	100.0000	100.0000	100.0000

A3.6. Concentrations (mol.%) of products produced over 1PtH-ZSM-5(80) catalyst at 490°C

Table: Mole%

Date: 01/06/06

Conversion of ethane-benzene over 1%Pt/HZSM5(80)-05 catalyst at 490°C.

Feed: 90mol% ethane, 10mol% Benzene

Comments: TOS, cat. weight = 0.0503 g

Feed flowrate = Ethane 16 ml/min

32 ml/min

Experiment	131-ETH	132-ETH	132-ETH0	132-ETH0	132-ETH0	133-ETH	134-ETH
Temper., °C	486	486	486	486	486	487	486
Tsat, oC	20.0	20.5	20.5	20.5	20.5	19.0	19.5
TOS, h	0.20	4.00	8.25	12.50	16.75	20.75	24.00
WHSV, h ⁻¹	29.22	30.42	30.42	30.42	30.42	31.01	63.62
Cont.time,h	0.0342	0.0329	0.0329	0.0329	0.0329	0.0322	0.0157
Conv. C2	4.881	4.708	4.347	3.956	3.616	3.306	1.985
Conv Benz	9.153	8.516	7.756	7.241	6.540	5.913	2.488
S1(E+B=E)	8.26	9.31	9.32	8.76	8.84	8.92	6.23
S2(B=EB)	83.76	90.31	93.02	94.21	94.86	95.27	97.30
S3(C2=)	37.33	40.88	41.15	41.50	41.57	41.62	44.56
S4 (H2)	51.82	48.17	48.37	48.80	48.71	48.68	48.92
S5 (DEBs)	1.40	1.66	1.70	1.49	1.37	1.26	0.73
S6 (TEB)	1.04	0.13	0.00	0.00	0.00	0.00	0.00
S7 (S2+S5)	86.19	92.10	94.72	95.69	96.24	96.53	98.03
Yield Et-Be	7.666	7.691	7.214	6.821	6.204	5.633	2.421
H2	4.4560	3.7980	3.5540	3.3255	3.0357	2.7744	1.7009
C1	0.0260	0.0177	0.0097	0.0072	0.0076	0.0048	0.0000
C2	82.8604	83.2879	83.8136	84.9960	85.3969	85.7424	87.7335
C2=	3.2105	3.2236	3.0234	2.8274	2.5908	2.3719	1.5491
C3	0.0208	0.0057	0.0026	0.0015	0.0009	0.0007	0.0000
C3=	0.0280	0.0158	0.0114	0.0092	0.0076	0.0065	0.0000
i-C4	0.0000	0.0000	0.0000	0.0000	0.0000	0.0000	0.0000
n-C4	0.0025	0.0023	0.0021	0.0020	0.0018	0.0017	0.0007
trans -C4=	0.0017	0.0017	0.0015	0.0014	0.0012	0.0010	0.0000
1-C4=	0.0008	0.0008	0.0007	0.0007	0.0006	0.0005	0.0000
iso-C4=	0.0025	0.0026	0.0022	0.0020	0.0017	0.0015	0.0005
cis-C4=	0.0011	0.0012	0.0010	0.0009	0.0008	0.0007	0.0000
C5	0.0000	0.0000	0.0000	0.0000	0.0000	0.0000	0.0000
16.0830	0.0018	0.0023	0.0023	0.0022	0.0022	0.0023	0.0027
Benzene	8.5401	8.8274	8.8390	8.1901	8.3713	8.5580	8.7900
Toluene	0.0116	0.0032	0.0021	0.0017	0.0015	0.0013	0.0004
Et-Benzene	0.7101	0.7343	0.6849	0.5971	0.5511	0.5082	0.2167
m/p Xylene	0.0022	0.0014	0.0012	0.0011	0.0009	0.0008	0.0000
o-Xylene	0.0005	0.0004	0.0003	0.0003	0.0003	0.0002	0.0000
iPB	0.0849	0.0485	0.0310	0.0219	0.0173	0.0146	0.0040
PB	0.0000	0.0000	0.0000	0.0000	0.0000	0.0000	0.0000
Et-Toluene	0.0086	0.0054	0.0029	0.0019	0.0014	0.0011	0.0000
A	0.0030	0.0016	0.0006	0.0005	0.0005	0.0005	0.0000
B	0.0062	0.0037	0.0007	0.0000	0.0000	0.0000	0.0000
1,3-DEB	0.0072	0.0078	0.0065	0.0050	0.0043	0.0037	0.0008
1,4-DEB	0.0041	0.0051	0.0054	0.0039	0.0034	0.0028	0.0008
1,2-DEB	0.0005	0.0006	0.0006	0.0005	0.0003	0.0003	0.0000
1,3,5-TEB	0.0088	0.0011	0.0000	0.0000	0.0000	0.0000	0.0000
1,2,4-TEB	0.0000	0.0000	0.0000	0.0000	0.0000	0.0000	0.0000
SUM DEB	0.0119	0.0135	0.0125	0.0094	0.0080	0.0067	0.0016
SUM Xyl	0.0028	0.0018	0.0015	0.0014	0.0012	0.0011	0.0000
Total	100.0000	100.0000	100.0000	100.0000	100.0000	100.0000	100.0000

Table: Mole%

Date: 22/05/06

Conversion of ethane-benzene over 1%Pt/HZSM5(80)-05 catalyst at 490°C.

Feed: 90mol% ethane, 10mol% Benzene

Comments: TOS, cat. weight = 0.2001g

Feed flowrate = Ethane 16 ml/min

32 ml/min

Experiment	101-ETH	102-ETH	102-ETH0	102-ETH0	102-ETH0	103-ETH	104-ETH
Temper., °C	487	487	487	487	487	487	487
Tsat, oC	20.0	20.0	20.0	20.0	20.0	19.5	19.5
TOS, h	0.20	4.00	8.25	12.50	16.75	20.75	24.25
WHSV, h ⁻¹	7.65	7.65	7.65	7.65	7.65	7.80	16.44
Cont.time,h	0.1307	0.1307	0.1307	0.1307	0.1307	0.1282	0.0608
Conv. C2	5.937	6.193	6.041	5.779	5.922	5.808	5.250
Conv Benz	13.545	15.677	15.014	14.799	14.239	14.180	11.030
S1(E+B=E)	7.41	9.55	10.26	9.46	10.78	10.45	9.78
S2(B=EB)	62.57	68.92	75.07	77.72	80.13	81.47	88.55
S3(C2=)	24.59	30.48	32.93	35.51	33.97	35.08	39.71
S4 (H2)	57.26	51.60	50.49	49.84	50.64	50.34	48.49
S5 (DEBs)	1.09	1.70	2.19	2.15	2.16	2.04	1.84
S6 (TEB)	6.86	2.26	1.35	0.72	0.61	0.50	0.29
S7 (S2+S5)	70.52	72.87	78.61	80.59	82.91	84.01	90.69
Yield Et-Be	8.476	10.804	11.270	11.502	11.410	11.553	9.767
H2	6.2714	5.4001	5.1255	4.8927	5.0846	4.9818	4.2864
C1	0.3465	0.1715	0.1047	0.0789	0.0566	0.0472	0.0177
C2	80.3998	81.5219	81.8332	83.1835	81.6893	82.3064	83.1971
C2=	2.6927	3.1898	3.3432	3.4866	3.4110	3.4715	3.5101
C3	0.2300	0.1457	0.0957	0.0708	0.0521	0.0423	0.0081
C3=	0.0917	0.0792	0.0680	0.0648	0.0593	0.0576	0.0259
i-C4	0.0034	0.0021	0.0012	0.0010	0.0008	0.0007	0.0000
n-C4	0.0064	0.0075	0.0074	0.0076	0.0070	0.0070	0.0034
trans -C4=	0.0031	0.0043	0.0042	0.0043	0.0040	0.0039	0.0023
1-C4=	0.0022	0.0030	0.0028	0.0030	0.0027	0.0027	0.0016
iso-C4=	0.0055	0.0076	0.0074	0.0075	0.0070	0.0068	0.0040
cis-C4=	0.0023	0.0031	0.0030	0.0032	0.0029	0.0029	0.0017
C5	0.0006	0.0010	0.0010	0.0011	0.0010	0.0010	0.0005
16.0940	0.0000	0.0007	0.0010	0.0009	0.0012	0.0012	0.0020
Benzene	8.6479	8.0130	8.0143	6.9992	8.2693	7.7973	7.9630
Toluene	0.1244	0.0552	0.0361	0.0274	0.0235	0.0208	0.0052
Et-Benzene	0.8112	0.9989	1.0413	0.9287	1.0828	1.0346	0.8643
m/p Xylene	0.0147	0.0111	0.0089	0.0074	0.0071	0.0065	0.0020
o-Xylene	0.0043	0.0032	0.0024	0.0021	0.0019	0.0017	0.0005
iPB	0.1641	0.2175	0.1849	0.1451	0.1527	0.1390	0.0730
PB	0.0009	0.0007	0.0005	0.0005	0.0005	0.0004	0.0002
Et-Toluene	0.0308	0.0440	0.0327	0.0236	0.0214	0.0179	0.0038
A	0.0063	0.0101	0.0071	0.0055	0.0056	0.0030	0.0015
B	0.0366	0.0514	0.0240	0.0202	0.0181	0.0137	0.0046
1,3-DEB	0.0089	0.0153	0.0161	0.0141	0.0161	0.0151	0.0100
1,4-DEB	0.0042	0.0076	0.0127	0.0103	0.0115	0.0097	0.0075
1,2-DEB	0.0010	0.0016	0.0016	0.0012	0.0016	0.0010	0.0005
1,3,5-TEB	0.0879	0.0319	0.0180	0.0086	0.0083	0.0064	0.0028
1,2,4-TEB	0.0010	0.0009	0.0007	0.0000	0.0000	0.0000	0.0000
SUM DEB	0.0141	0.0246	0.0303	0.0256	0.0292	0.0259	0.0180
SUM Xyl	0.0190	0.0143	0.0114	0.0095	0.0091	0.0082	0.0025
Total	100.0000	100.0000	100.0000	100.0000	100.0000	100.0000	100.0000

Table: Mole%

Date: 05/05/07

Conversion of ethane-benzene over 1%Pt/HZSM5(80) catalyst at 490oC.

Feed: 90mol% ethane, 10mol% Benzene

Comments: TOS, cat. weight = 0.5004g

Feed flowrate = Ethane 16 ml/min

8 ml/min 28 ml/min

Experiment	271-ETH	272-ETH	272-ETH0	273-ETH	274-ETH	275-ETH
Temper., °C	489	488	488	488	489	488
Tsat, oC	20.0	20.0	20.0	20.0	19.5	19.5
TOS, h	0.20	6.40	12.60	20.75	25.00	31.67
WHSV, h ⁻¹	3.12	3.14	3.14	3.18	1.54	5.52
Cont.time, h	0.3205	0.3185	0.3185	0.3145	0.6494	0.1812
Conv. C2	5.325	7.954	7.402	6.699	7.224	6.069
Conv Benz	12.674	23.058	22.638	19.795	19.823	16.303
S1(E+B=E)	3.78	7.55	8.47	9.15	9.13	10.56
S2(B=EB)	47.86	44.21	50.68	60.39	52.05	76.93
S3(C2=)	15.87	21.20	25.15	28.26	23.05	33.65
S4 (H2)	66.55	52.98	51.58	51.60	52.98	50.43
S5 (DEBs)	0.26	1.05	1.62	1.65	2.16	2.14
S6 (TEB)	8.01	7.65	5.70	4.14	4.16	1.26
S7 (S2+S5)	56.13	52.91	58.00	66.18	58.38	80.33
Yield Et-Ben	6.066	10.194	11.472	11.953	10.319	12.541
H2	8.2067	6.4238	5.8735	5.5815	6.0562	5.1252
C1	0.6457	0.5241	0.3091	0.1923	0.2458	0.0698
C2	80.6080	80.0164	81.3728	82.0302	79.8268	82.4215
C2=	1.9575	2.5703	2.8642	3.0572	2.6346	3.4200
C3	0.4120	0.3647	0.2745	0.1946	0.3080	0.0517
C3=	0.1077	0.1335	0.1219	0.1114	0.1368	0.0731
i-C4	0.0053	0.0049	0.0035	0.0024	0.0039	0.0000
n-C4	0.0086	0.0104	0.0111	0.0120	0.0143	0.0080
trans -C4=	0.0033	0.0050	0.0055	0.0056	0.0059	0.0045
1-C4=	0.0021	0.0032	0.0036	0.0037	0.0038	0.0030
iso-C4=	0.0056	0.0087	0.0094	0.0098	0.0102	0.0077
cis-C4=	0.0023	0.0036	0.0040	0.0041	0.0043	0.0033
C5	0.0006	0.0013	0.0016	0.0017	0.0019	0.0012
13.9320	0.0006	0.0009	0.0008	0.0007	0.0006	0.0005
Benzene	7.0600	7.8577	7.2405	7.1531	8.7431	7.4155
Toluene	0.2662	0.1945	0.1290	0.0877	0.1846	0.0254
Et-Benzene	0.4661	0.9158	0.9649	0.9902	1.0431	1.0732
m/p Xylene	0.0304	0.0345	0.0276	0.0208	0.0394	0.0071
o-Xylene	0.0091	0.0105	0.0084	0.0063	0.0129	0.0020
iPB	0.0698	0.2015	0.2034	0.1880	0.1875	0.1555
PB	0.0006	0.0014	0.0012	0.0011	0.0018	0.0007
Et-Toluene	0.0155	0.0850	0.0758	0.0500	0.0904	0.0156
A	0.0104	0.0204	0.0172	0.0126	0.0199	0.0065
B	0.0154	0.1700	0.1484	0.0902	0.2109	0.0254
1,3-DEB	0.0021	0.0139	0.0178	0.0168	0.0223	0.0175
1,4-DEB	0.0004	0.0078	0.0103	0.0083	0.0174	0.0109
1,2-DEB	0.0000	0.0000	0.0028	0.0019	0.0036	0.0015
1,3,5-TEB	0.0780	0.1564	0.1061	0.0653	0.0817	0.0176
1,2,4-TEB	0.0000	0.0022	0.0024	0.0026	0.0018	0.0000
C	0.0099	0.2575	0.1887	0.0979	0.0866	0.0362
SUM DEB	0.0025	0.0217	0.0309	0.0271	0.0433	0.0299
SUM Xyl	0.0395	0.0450	0.0360	0.0270	0.0523	0.0091
Total	100.0000	100.0000	100.0000	100.0000	100.0000	100.0000

A3.7. Concentrations (mol.%) of products produced over H-ZSM-5(72) catalyst at 370°C

Table: Mole%

Date: 03/02/08

Conversion of ethane-benzene over HZSM5(72) catalyst at 370oC.

Feed: 90mol% ethane, 10mol% Benzene

Comments: TOS, cat. weight = 0.5008g

Feed flowrate = Ethane 16 ml/min

8 ml/min

Experiment	501-ETH	501-ETH0	501-ETH0	501-ETH0	501-ETH0	502-ETH	503-ETH
Temper., °C	369	369	369	369	369	369	370
Tsat, oC	20.0	20.0	20.0	20.0	20.0	20.0	20.0
TOS, h	1.00	5.25	9.50	13.75	18.00	20.25	22.65
WHSV, h ⁻¹	3.13	3.13	3.13	3.13	3.13	3.17	1.70
Cont.time,h	0.3195	0.3195	0.3195	0.3195	0.3195	0.3155	0.5882
Conv. C2	0.038	0.029	0.028	0.028	0.026	0.029	0.028
Conv Benz	0.288	0.239	0.231	0.239	0.216	0.213	0.198
S1(E+B=E)	29.45	64.71	67.57	68.21	69.10	70.55	70.32
S2(B=EB)	93.16	96.03	95.97	95.71	95.13	95.53	94.01
S3(C2=)	7.65	13.69	13.81	13.13	12.56	11.05	10.22
S4 (H2)	57.06	10.52	6.92	7.68	5.69	5.31	5.23
S5 (DEBs)	0.00	0.00	0.00	0.00	0.00	0.00	0.00
S6 (TEB)	0.00	0.00	0.00	0.00	0.00	0.00	0.00
S7 (S2+S5)	93.16	96.03	95.97	95.71	95.13	95.53	94.01
Yield Et-Be	0.268	0.230	0.222	0.228	0.205	0.204	0.186
H2	0.0415	0.0030	0.0018	0.0020	0.0014	0.0014	0.0013
C1	0.0000	0.0000	0.0000	0.0000	0.0000	0.0000	0.0000
C2	91.9186	92.0259	92.0529	92.0625	91.8644	91.1019	90.4832
C2=	0.0056	0.0039	0.0036	0.0035	0.0030	0.0028	0.0026
C3	0.0000	0.0000	0.0000	0.0000	0.0000	0.0000	0.0000
C3=	0.0000	0.0000	0.0000	0.0000	0.0000	0.0000	0.0000
i-C4	0.0000	0.0000	0.0000	0.0000	0.0000	0.0000	0.0000
n-C4	0.0017	0.0014	0.0013	0.0011	0.0012	0.0013	0.0014
trans -C4=	0.0000	0.0000	0.0000	0.0000	0.0000	0.0000	0.0000
1-C4=	0.0000	0.0000	0.0000	0.0000	0.0000	0.0000	0.0000
iso-C4=	0.0000	0.0000	0.0000	0.0000	0.0000	0.0000	0.0000
cis-C4=	0.0000	0.0000	0.0000	0.0000	0.0000	0.0000	0.0000
C5	0.0000	0.0000	0.0000	0.0000	0.0000	0.0000	0.0000
16.1090	0.0010	0.0009	0.0010	0.0010	0.0010	0.0012	0.0011
Benzene	8.0086	7.9460	7.9212	7.9111	8.1116	8.8725	9.4917
Toluene	0.0008	0.0003	0.0003	0.0003	0.0003	0.0003	0.0005
Et-Benzene	0.0214	0.0182	0.0175	0.0180	0.0166	0.0180	0.0176
m/p Xylene	0.0000	0.0000	0.0000	0.0000	0.0000	0.0000	0.0000
o-Xylene	0.0000	0.0000	0.0000	0.0000	0.0000	0.0000	0.0000
iPB	0.0008	0.0005	0.0005	0.0005	0.0006	0.0006	0.0006
PB	0.0000	0.0000	0.0000	0.0000	0.0000	0.0000	0.0000
Et-Toluene	0.0000	0.0000	0.0000	0.0000	0.0000	0.0000	0.0000
A	0.0000	0.0000	0.0000	0.0000	0.0000	0.0000	0.0000
B	0.0000	0.0000	0.0000	0.0000	0.0000	0.0000	0.0000
1,3-DEB	0.0000	0.0000	0.0000	0.0000	0.0000	0.0000	0.0000
1,4-DEB	0.0000	0.0000	0.0000	0.0000	0.0000	0.0000	0.0000
1,2-DEB	0.0000	0.0000	0.0000	0.0000	0.0000	0.0000	0.0000
TEB	0.0000	0.0000	0.0000	0.0000	0.0000	0.0000	0.0000
SUM DEB	0.0000	0.0000	0.0000	0.0000	0.0000	0.0000	0.0000
SUM Xyl	0.0000	0.0000	0.0000	0.0000	0.0000	0.0000	0.0000
Total	100.0000	100.0000	100.0000	100.0000	100.0000	100.0000	100.0000

Table: Mole%

Date: 03/02/08

Conversion of ethane-benzene over HZSM5(72) catalyst at 370oC.

Feed: 90mol% ethane, 10mol% Benzene

Comments: TOS, cat. weight = 0.5008g

Feed flow: 32 ml/min 8 ml/min 64 ml/min

96 ml/min

Experiment	504-ETH	505-ETH	506-ETH	506-ETH0	506-ETH0	506-ETH0	507-ETH
Temper., °C	369	370	369	370	370	370	368
Tsat, oC	20.0	20.0	19.5	20.0	20.0	20.0	20.0
TOS, h	25.00	26.25	27.50	31.75	36.00	40.25	44.75
WHSV, h ⁻¹	6.39	1.50	12.34	3.17	3.17	3.17	18.77
Cont.time, h	0.1565	0.6667	0.0810	0.3155	0.3155	0.3155	0.0533
Conv. C2	0.025	0.030	0.026	0.027	0.027	0.027	0.026
Conv Benz	0.166	0.195	0.154	0.203	0.200	0.198	0.131
S1(E+B=E)	70.23	73.11	59.89	71.00	71.10	70.46	50.55
S2(B=EB)	100.00	96.99	100.00	97.22	97.11	96.98	100.00
S3(C2=)	12.26	9.14	21.97	10.69	10.59	10.62	30.32
S4 (H2)	6.03	5.13	6.05	5.54	5.76	5.82	6.13
S5 (DEBs)	0.00	0.00	0.00	0.00	0.00	0.00	0.00
S6 (TEB)	0.00	0.00	0.00	0.00	0.00	0.00	0.00
S7 (S2+S5)	100.00	96.99	100.00	97.22	97.11	96.98	100.00
Yield Et-Be	0.166	0.189	0.154	0.197	0.194	0.192	0.131
H2	0.0014	0.0014	0.0014	0.0013	0.0014	0.0014	0.0014
C1	0.0000	0.0000	0.0000	0.0000	0.0000	0.0000	0.0000
C2	90.4764	89.7412	91.2212	91.2770	91.1877	91.2707	91.3250
C2=	0.0027	0.0024	0.0049	0.0026	0.0025	0.0025	0.0068
C3	0.0000	0.0000	0.0000	0.0000	0.0000	0.0000	0.0000
C3=	0.0000	0.0000	0.0000	0.0000	0.0000	0.0000	0.0000
i-C4	0.0000	0.0000	0.0000	0.0000	0.0000	0.0000	0.0000
n-C4	0.0015	0.0016	0.0014	0.0015	0.0014	0.0015	0.0016
trans -C4=	0.0000	0.0000	0.0000	0.0000	0.0000	0.0000	0.0000
1-C4=	0.0000	0.0000	0.0000	0.0000	0.0000	0.0000	0.0000
iso-C4=	0.0000	0.0000	0.0000	0.0000	0.0000	0.0000	0.0000
cis-C4=	0.0000	0.0000	0.0000	0.0000	0.0000	0.0000	0.0000
C5	0.0000	0.0000	0.0000	0.0000	0.0000	0.0000	0.0000
16.2090	0.0011	0.0011	0.0013	0.0011	0.0011	0.0011	0.0013
Benzene	9.5012	10.2324	8.7565	8.6990	8.7884	8.7056	8.6526
Toluene	0.0000	0.0000	0.0000	0.0000	0.0000	0.0000	0.0000
Et-Benzene	0.0157	0.0193	0.0134	0.0171	0.0170	0.0167	0.0113
m/p Xylene	0.0000	0.0000	0.0000	0.0000	0.0000	0.0000	0.0000
o-Xylene	0.0000	0.0000	0.0000	0.0000	0.0000	0.0000	0.0000
iPB	0.0000	0.0006	0.0000	0.0005	0.0005	0.0005	0.0000
PB	0.0000	0.0000	0.0000	0.0000	0.0000	0.0000	0.0000
Et-Toluene	0.0000	0.0000	0.0000	0.0000	0.0000	0.0000	0.0000
A	0.0000	0.0000	0.0000	0.0000	0.0000	0.0000	0.0000
B	0.0000	0.0000	0.0000	0.0000	0.0000	0.0000	0.0000
1,3-DEB	0.0000	0.0000	0.0000	0.0000	0.0000	0.0000	0.0000
1,4-DEB	0.0000	0.0000	0.0000	0.0000	0.0000	0.0000	0.0000
1,2-DEB	0.0000	0.0000	0.0000	0.0000	0.0000	0.0000	0.0000
TEB	0.0000	0.0000	0.0000	0.0000	0.0000	0.0000	0.0000
SUM DEB	0.0000	0.0000	0.0000	0.0000	0.0000	0.0000	0.0000
SUM Xyl	0.0000	0.0000	0.0000	0.0000	0.0000	0.0000	0.0000
Total	100.0000	100.0000	100.0000	100.0000	100.0000	100.0000	100.0000

A3.8. Concentrations (mol.%) of products produced over 0.01PtH-ZSM-5(72) catalyst at 370°C

Table: Mole%

Date: 05/06/08

Conversion of ethane-benzene over 0.01%Pt/HZSM5(72) catalyst at 370oC.

Feed: 90mol% ethane, 10mol% Benzene

Comments: TOS, cat. weight = 0.1004g

Feed flowrate = Ethane 16 ml/min

32 ml/min

Experiment	631-ETH	632-ETH	632-ETH0	632-ETH0	632-ETH0	633-ETH	634-ETH
Temper., °C	370	370	370	370	370	370	369
Tsat, oC	20.0	20.0	20.0	20.0	20.0	20.0	20.0
TOS, h	1.00	4.50	8.75	13.00	17.25	20.30	22.00
WHSV, h ⁻¹	15.24	15.14	15.14	15.14	15.14	15.54	34.48
Cont.time, h	0.0656	0.0661	0.0661	0.0661	0.0661	0.0644	0.0290
Conv. C2	0.446	0.396	0.379	0.363	0.340	0.327	0.140
Conv Benz	2.244	1.947	1.850	1.750	1.657	1.611	0.418
S1(E+B=E)	26.08	25.15	24.09	23.43	22.72	23.65	14.35
S2(B=EB)	96.49	99.07	99.27	99.19	99.21	99.27	100.00
S3(C2=)	25.56	25.15	25.17	25.97	26.50	26.03	34.69
S4 (H2)	46.48	49.29	50.39	50.23	50.43	49.97	50.50
S5 (DEBs)	0.72	0.00	0.00	0.00	0.00	0.00	0.00
S6 (TEB)	0.00	0.00	0.00	0.00	0.00	0.00	0.00
S7 (S2+S5)	97.21	99.07	99.27	99.19	99.21	99.27	100.00
Yield Et-Be	2.165	1.929	1.836	1.736	1.644	1.599	0.418
H2	0.3528	0.3492	0.3487	0.3322	0.3146	0.2971	0.1280
C1	0.0036	0.0000	0.0000	0.0000	0.0000	0.0000	0.0000
C2	90.2390	90.1808	90.3501	90.5188	90.8506	90.7104	91.0231
C2=	0.1940	0.1782	0.1742	0.1718	0.1653	0.1547	0.0879
C3	0.0000	0.0000	0.0000	0.0000	0.0000	0.0000	0.0000
C3=	0.0023	0.0000	0.0000	0.0000	0.0000	0.0000	0.0000
i-C4	0.0000	0.0000	0.0000	0.0000	0.0000	0.0000	0.0000
n-C4	0.0000	0.0000	0.0000	0.0000	0.0000	0.0000	0.0000
trans -C4=	0.0000	0.0000	0.0000	0.0000	0.0000	0.0000	0.0000
1-C4=	0.0000	0.0000	0.0000	0.0000	0.0000	0.0000	0.0000
iso-C4=	0.0000	0.0000	0.0000	0.0000	0.0000	0.0000	0.0000
cis-C4=	0.0000	0.0000	0.0000	0.0000	0.0000	0.0000	0.0000
C5	0.0000	0.0000	0.0000	0.0000	0.0000	0.0000	0.0000
18.9170	0.0012	0.0012	0.0012	0.0012	0.0011	0.0011	0.0012
Benzene	9.0020	9.1107	8.9579	8.8198	8.5255	8.6952	8.7233
Toluene	0.0012	0.0000	0.0000	0.0000	0.0000	0.0000	0.0000
Et-Benzene	0.1980	0.1782	0.1667	0.1549	0.1417	0.1406	0.0364
m/p Xylene	0.0000	0.0000	0.0000	0.0000	0.0000	0.0000	0.0000
o-Xylene	0.0000	0.0000	0.0000	0.0000	0.0000	0.0000	0.0000
iPB	0.0041	0.0017	0.0012	0.0013	0.0011	0.0010	0.0000
PB	0.0000	0.0000	0.0000	0.0000	0.0000	0.0000	0.0000
Et-Toluene	0.0004	0.0000	0.0000	0.0000	0.0000	0.0000	0.0000
A	0.0000	0.0000	0.0000	0.0000	0.0000	0.0000	0.0000
B	0.0000	0.0000	0.0000	0.0000	0.0000	0.0000	0.0000
1,3-DEB	0.0008	0.0000	0.0000	0.0000	0.0000	0.0000	0.0000
1,4-DEB	0.0007	0.0000	0.0000	0.0000	0.0000	0.0000	0.0000
1,2-DEB	0.0000	0.0000	0.0000	0.0000	0.0000	0.0000	0.0000
TEB	0.0000	0.0000	0.0000	0.0000	0.0000	0.0000	0.0000
SUM DEB	0.0015	0.0000	0.0000	0.0000	0.0000	0.0000	0.0000
SUM Xyl	0.0000	0.0000	0.0000	0.0000	0.0000	0.0000	0.0000
Total	100.0000	100.0000	100.0000	100.0000	100.0000	100.0000	100.0000

Table: Mole%

Date: 05/06/08

Conversion of ethane-benzene over 0.01%Pt/HZSM5(72) catalyst at 370oC.

Feed: 90mol% ethane, 10mol% Benzene

Comments: TOS, cat. weight = 0.1004g

Feed flow: 64 ml/min 96 ml/min

Experiment	634-ETH	635-ETH	636-ETH
Temper., °C	368	367	370
Tsat, oC	20.0	20.0	20.0
TOS, h	23.40	25.20	26.30
WHSV, h ⁻¹	60.56	89.14	15.54
Cont.time, h	0.0165	0.0112	0.0644
Conv. C2	0.047	0.020	0.256
Conv Benz	0.080	0.024	1.257
S1(E+B=E)	8.39	5.77	23.92
S2(B=EB)	100.00	100.00	99.30
S3(C2=)	39.10	39.52	25.44
S4 (H2)	51.07	51.26	50.22
S5 (DEBs)	0.00	0.00	0.00
S6 (TEB)	0.00	0.00	0.00
S7 (S2+S5)	100.00	100.00	99.30
Yield Et-Be	0.080	0.024	1.248
H2	0.0424	0.0172	0.2339
C1	0.0000	0.0000	0.0000
C2	91.1570	91.7945	90.6723
C2=	0.0325	0.0132	0.1185
C3	0.0000	0.0000	0.0000
C3=	0.0000	0.0000	0.0000
i-C4	0.0000	0.0000	0.0000
n-C4	0.0000	0.0000	0.0000
trans -C4=	0.0000	0.0000	0.0000
1-C4=	0.0000	0.0000	0.0000
iso-C4=	0.0000	0.0000	0.0000
cis-C4=	0.0000	0.0000	0.0000
C5	0.0000	0.0000	0.0000
18.9170	0.0012	0.0012	0.0011
Benzene	8.7599	8.1720	8.8619
Toluene	0.0000	0.0000	0.0000
Et-Benzen	0.0070	0.0019	0.1114
m/p Xylene	0.0000	0.0000	0.0000
o-Xylene	0.0000	0.0000	0.0000
iPB	0.0000	0.0000	0.0008
PB	0.0000	0.0000	0.0000
Et-Toluene	0.0000	0.0000	0.0000
A	0.0000	0.0000	0.0000
B	0.0000	0.0000	0.0000
1,3-DEB	0.0000	0.0000	0.0000
1,4-DEB	0.0000	0.0000	0.0000
1,2-DEB	0.0000	0.0000	0.0000
TEB	0.0000	0.0000	0.0000
SUM DEB	0.0000	0.0000	0.0000
SUM Xyl	0.0000	0.0000	0.0000
Total	100.0000	100.0000	100.0000

Table: Mole%

Date: 11/06/08

Conversion of ethane-benzene over 0.01%Pt/HZSM5(72) catalyst at 370oC.

Feed: 90mol% ethane, 10mol% Benzene

Comments: TOS, cat. weight = 0.5030g

Feed flowrate = Ethane 16 ml/min

8 ml/min

Experiment	641-ETH	642-ETH	642-ETH0	642-ETH0	642-ETH0	643-ETH	644-ETH
Temper., °C	369	369	369	369	369	369	369
Tsat, oC	20.0	20.0	20.0	20.0	20.0	20.0	20.0
TOS, h	1.00	4.50	8.75	13.00	17.25	20.30	23.60
WHSV, h ⁻¹	2.98	3.02	3.02	3.02	3.02	3.02	1.51
Cont.time, h	0.3356	0.3311	0.3311	0.3311	0.3311	0.3311	0.6623
Conv. C2	1.181	1.204	1.176	1.167	1.164	1.159	1.448
Conv Benz	8.304	9.090	8.848	8.846	8.916	8.765	11.690
S1(E+B=E)	39.34	38.80	39.50	38.68	38.75	38.72	39.78
S2(B=EB)	93.77	96.14	96.46	96.36	96.40	96.41	95.16
S3(C2=)	13.26	8.83	8.87	8.60	8.70	8.80	6.41
S4 (H2)	42.84	50.45	49.85	50.93	50.78	50.69	51.21
S5 (DEBs)	2.14	1.94	1.80	1.87	1.81	1.87	2.14
S6 (TEB)	0.44	0.05	0.04	0.05	0.05	0.05	0.14
S7 (S2+S5)	96.36	98.13	98.30	98.27	98.26	98.33	97.44
Yield Et-Bz	7.786	8.739	8.535	8.523	8.596	8.451	11.125
H2	0.8001	1.0886	1.0411	1.0747	1.0677	1.0580	1.3434
C1	0.0191	0.0000	0.0000	0.0000	0.0000	0.0000	0.0000
C2	89.3744	89.0450	89.0185	89.0762	89.1809	89.1037	89.0051
C2=	0.2477	0.1905	0.1852	0.1814	0.1830	0.1838	0.1681
C3	0.0088	0.0036	0.0027	0.0026	0.0026	0.0023	0.0096
C3=	0.0055	0.0026	0.0025	0.0025	0.0025	0.0025	0.0031
i-C4	0.0000	0.0000	0.0000	0.0000	0.0000	0.0000	0.0000
n-C4	0.0011	0.0008	0.0007	0.0008	0.0008	0.0014	0.0017
trans -C4=	0.0000	0.0000	0.0000	0.0000	0.0000	0.0000	0.0000
1-C4=	0.0000	0.0000	0.0000	0.0000	0.0000	0.0000	0.0000
iso-C4=	0.0009	0.0000	0.0000	0.0000	0.0000	0.0000	0.0000
cis-C4=	0.0000	0.0000	0.0000	0.0000	0.0000	0.0000	0.0000
C5	0.0000	0.0000	0.0000	0.0000	0.0000	0.0000	0.0000
16.3880	0.0010	0.0009	0.0009	0.0009	0.0010	0.0010	0.0007
Benzene	8.7581	8.7970	8.8932	8.8137	8.7164	8.8092	8.3718
Toluene	0.0099	0.0030	0.0025	0.0024	0.0024	0.0021	0.0087
Et-Benzene	0.7346	0.8374	0.8249	0.8162	0.8148	0.8082	1.0434
m/p Xylene	0.0000	0.0000	0.0000	0.0000	0.0000	0.0000	0.0011
o-Xylene	0.0000	0.0000	0.0000	0.0000	0.0000	0.0000	0.0005
iPB	0.0107	0.0102	0.0095	0.0097	0.0095	0.0094	0.0115
PB	0.0009	0.0004	0.0004	0.0004	0.0004	0.0004	0.0006
Et-Toluene	0.0044	0.0019	0.0015	0.0015	0.0017	0.0015	0.0045
A	0.0027	0.0007	0.0006	0.0007	0.0007	0.0006	0.0012
B	0.0000	0.0000	0.0000	0.0000	0.0000	0.0000	0.0000
1,3-DEB	0.0103	0.0107	0.0099	0.0100	0.0096	0.0099	0.0146
1,4-DEB	0.0060	0.0057	0.0050	0.0052	0.0051	0.0051	0.0076
1,2-DEB	0.0005	0.0006	0.0005	0.0006	0.0006	0.0006	0.0012
TEB	0.0035	0.0004	0.0003	0.0004	0.0004	0.0004	0.0015
SUM DEB	0.0168	0.0169	0.0154	0.0158	0.0153	0.0157	0.0234
SUM Xyl	0.0000	0.0000	0.0000	0.0000	0.0000	0.0000	0.0016
Total	100.0000	100.0000	100.0000	100.0000	100.0000	100.0000	100.0000

Table: Mole%

Date: 11/06/08

Conversion of ethane-benzene over 0.01%Pt/HZSM5(72) catalyst at 370oC.

Feed: 90mol% ethane, 10mol% Benzene

Comments: TOS, cat. weight = 0.5030g

Feed flowr: 16 ml/min 64 ml/min

96 ml/min

Experiment	645-ETH	646-ETH	646-ETH0	646-ETH0	646-ETH0	647-ETH
Temper., °C	369	368	369	369	369	366
Tsat, oC	20.0	20.0	20.0	20.0	20.0	20.0
TOS, h	26.85	28.50	32.75	37.00	41.25	45.50
WHSV, h ⁻¹	5.92	11.63	3.02	3.02	3.02	17.38
Cont.time, h	0.1689	0.0860	0.3311	0.3311	0.3311	0.0575
Conv. C2	0.779	0.480	1.103	1.088	1.076	0.319
Conv Benz	5.331	2.348	8.688	8.648	8.727	1.154
S1(E+B=E)	33.26	22.62	38.40	38.44	38.10	15.20
S2(B=EB)	97.45	99.17	96.62	96.72	96.83	99.29
S3(C2=)	15.33	26.28	9.30	9.35	9.47	33.28
S4 (H2)	50.38	50.79	50.69	50.63	50.91	51.23
S5 (DEBs)	1.46	0.00	1.76	1.77	1.67	0.00
S6 (TEB)	0.00	0.00	0.00	0.00	0.00	0.00
S7 (S2+S5)	98.91	99.17	98.38	98.49	98.50	99.29
Yield Et-Be	5.195	2.329	8.395	8.365	8.450	1.145
H2	0.7114	0.4506	1.0147	0.9996	1.0018	0.3059
C1	0.0000	0.0000	0.0000	0.0000	0.0000	0.0000
C2	89.9572	90.6500	89.5593	89.6619	89.8612	91.5270
C2=	0.2165	0.2331	0.1861	0.1847	0.1864	0.1987
C3	0.0000	0.0000	0.0020	0.0020	0.0021	0.0000
C3=	0.0012	0.0000	0.0024	0.0024	0.0025	0.0000
i-C4	0.0000	0.0000	0.0000	0.0000	0.0000	0.0000
n-C4	0.0000	0.0000	0.0000	0.0000	0.0000	0.0000
trans -C4=	0.0000	0.0000	0.0000	0.0000	0.0000	0.0000
1-C4=	0.0000	0.0000	0.0000	0.0000	0.0000	0.0000
iso-C4=	0.0000	0.0000	0.0000	0.0000	0.0000	0.0000
cis-C4=	0.0000	0.0000	0.0000	0.0000	0.0000	0.0000
C5	0.0000	0.0000	0.0000	0.0000	0.0000	0.0000
18.9170	0.0011	0.0011	0.0010	0.0009	0.0009	0.0011
Benzene	8.6307	8.4627	8.4389	8.3638	8.1708	7.8759
Toluene	0.0000	0.0000	0.0020	0.0019	0.0019	0.0000
Et-Benzene	0.4696	0.2007	0.7687	0.7589	0.7498	0.0908
m/p Xylene	0.0000	0.0000	0.0000	0.0000	0.0000	0.0000
o-Xylene	0.0000	0.0000	0.0000	0.0000	0.0000	0.0000
iPB	0.0052	0.0017	0.0090	0.0088	0.0086	0.0006
PB	0.0000	0.0000	0.0000	0.0000	0.0000	0.0000
Et-Toluene	0.0000	0.0000	0.0013	0.0012	0.0011	0.0000
A	0.0000	0.0000	0.0006	0.0000	0.0000	0.0000
B	0.0000	0.0000	0.0000	0.0000	0.0000	0.0000
1,3-DEB	0.0045	0.0000	0.0091	0.0090	0.0085	0.0000
1,4-DEB	0.0025	0.0000	0.0049	0.0049	0.0045	0.0000
1,2-DEB	0.0000	0.0000	0.0000	0.0000	0.0000	0.0000
TEB	0.0000	0.0000	0.0000	0.0000	0.0000	0.0000
SUM DEB	0.0070	0.0000	0.0140	0.0139	0.0129	0.0000
SUM Xyl	0.0000	0.0000	0.0000	0.0000	0.0000	0.0000
Total	100.0000	100.0000	100.0000	100.0000	100.0000	100.0000

A3.9. Concentrations (mol.%) of products produced over 0.025PtH-ZSM-5(72) catalyst at 370°C

Table: Mole%

Date: 23/05/08

Conversion of ethane-benzene over 0.025%Pt/HZSM5(72) catalyst at 370oC.

Feed: 90mol% ethane, 10mol% Benzene

Comments: TOS, cat. weight = 0.1001g

Feed flowrate = Ethane 16 ml/min

32 ml/min

Experiment	611-ETH	612-ETH	612-ETH0	612-ETH0	612-ETH0	613-ETH	614-ETH
Temper., °C	369	369	369	369	369	368	368
Tsat, oC	20.0	20.0	20.0	20.0	20.0	20.0	20.0
TOS, h	1.00	4.50	8.75	13.00	17.25	20.90	22.60
WHSV, h ⁻¹	15.28	15.54	15.54	15.54	15.54	15.68	31.37
Cont.time,h	0.0654	0.0644	0.0644	0.0644	0.0644	0.0638	0.0319
Conv. C2	0.624	0.666	0.650	0.629	0.608	0.591	0.347
Conv Benz	2.893	3.238	3.090	3.155	3.044	2.651	0.998
S1(E+B=E)	26.41	25.56	25.06	23.38	23.02	24.27	15.43
S2(B=EB)	95.43	98.87	98.98	98.94	99.01	99.09	99.47
S3(C2=)	25.81	23.94	24.24	25.55	26.21	25.13	34.36
S4 (H2)	45.12	50.11	50.34	50.72	50.45	50.26	49.91
S5 (DEBs)	0.98	0.00	0.00	0.00	0.00	0.00	0.00
S6 (TEB)	0.00	0.00	0.00	0.00	0.00	0.00	0.00
S7 (S2+S5)	96.41	98.87	98.98	98.94	99.01	99.09	99.47
Yield Et-Be	2.761	3.202	3.058	3.122	3.014	2.627	0.992
H2	0.4644	0.6026	0.5929	0.5880	0.5636	0.5361	0.3104
C1	0.0077	0.0000	0.0000	0.0000	0.0000	0.0000	0.0000
C2	89.3364	89.4547	89.4176	90.3850	90.5644	89.2863	89.7476
C2=	0.2656	0.2879	0.2855	0.2962	0.2928	0.2680	0.2137
C3	0.0014	0.0000	0.0000	0.0000	0.0000	0.0000	0.0000
C3=	0.0040	0.0000	0.0000	0.0000	0.0000	0.0000	0.0000
i-C4	0.0000	0.0000	0.0000	0.0000	0.0000	0.0000	0.0000
n-C4	0.0000	0.0000	0.0000	0.0000	0.0000	0.0000	0.0000
trans -C4=	0.0000	0.0000	0.0000	0.0000	0.0000	0.0000	0.0000
1-C4=	0.0000	0.0000	0.0000	0.0000	0.0000	0.0000	0.0000
iso-C4=	0.0000	0.0000	0.0000	0.0000	0.0000	0.0000	0.0000
cis-C4=	0.0000	0.0000	0.0000	0.0000	0.0000	0.0000	0.0000
C5	0.0000	0.0000	0.0000	0.0000	0.0000	0.0000	0.0000
16.4440	0.0013	0.0012	0.0012	0.0011	0.0011	0.0013	0.0013
Benzene	9.6345	9.3426	9.4046	8.4557	8.3184	9.6470	9.6305
Toluene	0.0023	0.0000	0.0000	0.0000	0.0000	0.0000	0.0000
Et-Benzene	0.2718	0.3074	0.2952	0.2711	0.2572	0.2589	0.0960
m/p Xylene	0.0000	0.0000	0.0000	0.0000	0.0000	0.0000	0.0000
o-Xylene	0.0000	0.0000	0.0000	0.0000	0.0000	0.0000	0.0000
iPB	0.0057	0.0035	0.0030	0.0029	0.0026	0.0024	0.0005
PB	0.0007	0.0000	0.0000	0.0000	0.0000	0.0000	0.0000
Et-Toluene	0.0011	0.0000	0.0000	0.0000	0.0000	0.0000	0.0000
A	0.0005	0.0000	0.0000	0.0000	0.0000	0.0000	0.0000
B	0.0000	0.0000	0.0000	0.0000	0.0000	0.0000	0.0000
1,3-DEB	0.0015	0.0000	0.0000	0.0000	0.0000	0.0000	0.0000
1,4-DEB	0.0013	0.0000	0.0000	0.0000	0.0000	0.0000	0.0000
1,2-DEB	0.0000	0.0000	0.0000	0.0000	0.0000	0.0000	0.0000
TEB	0.0000	0.0000	0.0000	0.0000	0.0000	0.0000	0.0000
SUM DEB	0.0028	0.0000	0.0000	0.0000	0.0000	0.0000	0.0000
SUM Xyl	0.0000	0.0000	0.0000	0.0000	0.0000	0.0000	0.0000
Total	100.0000	100.0000	100.0000	100.0000	100.0000	100.0000	100.0000

Table: Mole%

Date: 23/05/08

Conversion of ethane-benzene over 0.025%Pt/HZSM5(72) catalyst at 370oC.

Feed: 90mol% ethane, 10mol% Benzene

Comments: TOS, cat. weight = 0.1001g

Feed flow: 64 ml/min 96 ml/min 10 ml/min

Experiment	615-ETH	616-ETH	617-ETH	618-ETH
Temper., °C	367	365	368	368
Tsat, oC	20.0	20.0	20.0	20.0
TOS, h	23.20	24.10	25.05	24.75
WHSV, h ⁻¹	57.54	87.31	9.39	15.48
Cont.time, h	0.0174	0.0115	0.1065	0.0646
Conv. C2	0.116	0.070	0.624	0.580
Conv Benz	0.184	0.083	3.710	2.752
S1(E+B=E)	7.69	5.40	30.46	24.65
S2(B=EB)	100.00	100.00	100.00	98.85
S3(C2=)	41.11	42.67	19.90	25.47
S4 (H2)	50.62	51.07	49.54	49.48
S5 (DEBs)	0.00	0.00	0.00	0.27
S6 (TEB)	0.00	0.00	0.00	0.00
S7 (S2+S5)	100.00	100.00	100.00	99.12
Yield Et-Be	0.184	0.083	3.710	2.721
H2	0.1058	0.0647	0.5577	0.5129
C1	0.0000	0.0000	0.0000	0.0000
C2	91.0388	91.6009	89.9220	89.7735
C2=	0.0859	0.0540	0.2241	0.2640
C3	0.0000	0.0000	0.0000	0.0000
C3=	0.0000	0.0000	0.0000	0.0000
i-C4	0.0000	0.0000	0.0000	0.0000
n-C4	0.0000	0.0000	0.0000	0.0000
trans -C4=	0.0000	0.0000	0.0000	0.0000
1-C4=	0.0000	0.0000	0.0000	0.0000
iso-C4=	0.0000	0.0000	0.0000	0.0000
cis-C4=	0.0000	0.0000	0.0000	0.0000
C5	0.0000	0.0000	0.0000	0.0000
18.9170	0.0012	0.0011	0.0011	0.0012
Benzene	8.7522	8.2724	8.9521	9.1899
Toluene	0.0000	0.0000	0.0000	0.0000
Et-Benzene	0.0161	0.0068	0.3430	0.2555
m/p Xylene	0.0000	0.0000	0.0000	0.0000
o-Xylene	0.0000	0.0000	0.0000	0.0000
iPB	0.0000	0.0000	0.0000	0.0023
PB	0.0000	0.0000	0.0000	0.0000
Et-Toluene	0.0000	0.0000	0.0000	0.0000
A	0.0000	0.0000	0.0000	0.0000
B	0.0000	0.0000	0.0000	0.0000
1,3-DEB	0.0000	0.0000	0.0000	0.0007
1,4-DEB	0.0000	0.0000	0.0000	0.0000
1,2-DEB	0.0000	0.0000	0.0000	0.0000
TEB	0.0000	0.0000	0.0000	0.0000
SUM DEB	0.0000	0.0000	0.0000	0.0007
SUM Xyl	0.0000	0.0000	0.0000	0.0000
Total	100.0000	100.0000	100.0000	100.0000

Table: Mole%

Date: 19/05/08

Conversion of ethane-benzene over 0.025%Pt/HZSM5(72) catalyst at 370oC.

Feed: 90mol% ethane, 10mol% Benzene

Comments: TOS, cat. weight = 0.2000g

Feed flowrate = Ethane 16 ml/min

12 ml/min

Experiment	601-ETH	602-ETH	602-ETH0	602-ETH0	602-ETH0	603-ETH	604-ETH
Temper., °C	369	369	369	369	369	369	369
Tsat, oC	20.0	20.0	20.0	20.0	20.0	20.0	20.0
TOS, h	1.00	4.25	8.50	12.75	17.00	20.40	22.90
WHSV, h ⁻¹	7.80	7.75	7.75	7.75	7.75	7.75	5.55
Cont.time, h	0.1282	0.1290	0.1290	0.1290	0.1290	0.1290	0.1802
Conv. C2	1.275	1.126	1.116	1.066	1.069	1.091	1.204
Conv Benz	8.077	7.385	7.288	7.419	7.446	7.259	8.288
S1(E+B=E)	32.34	32.72	32.82	31.41	31.62	32.19	34.48
S2(B=EB)	92.62	94.66	95.10	94.96	94.94	94.81	94.81
S3(C2=)	12.74	13.78	14.25	15.12	15.18	14.72	12.30
S4 (H2)	48.59	51.26	50.88	51.45	51.17	51.00	50.94
S5 (DEBs)	1.97	2.02	1.85	1.91	1.92	2.06	2.16
S6 (TEB)	0.46	0.00	0.00	0.00	0.00	0.00	0.00
S7 (S2+S5)	95.05	96.69	96.94	96.88	96.87	96.87	96.96
Yield Et-Be	7.481	6.991	6.931	7.045	7.070	6.882	7.857
H2	1.0657	1.0435	1.0224	1.0063	0.9978	1.0053	1.1028
C1	0.0395	0.0000	0.0000	0.0000	0.0000	0.0000	0.0000
C2	88.9880	89.0549	89.0876	89.8963	89.9031	89.3943	89.0364
C2=	0.2794	0.2806	0.2864	0.2957	0.2961	0.2902	0.2662
C3	0.0362	0.0055	0.0045	0.0044	0.0043	0.0041	0.0058
C3=	0.0036	0.0015	0.0016	0.0016	0.0017	0.0016	0.0018
i-C4	0.0000	0.0000	0.0000	0.0000	0.0000	0.0000	0.0000
n-C4	0.0025	0.0000	0.0000	0.0000	0.0000	0.0000	0.0000
trans -C4=	0.0000	0.0000	0.0000	0.0000	0.0000	0.0000	0.0000
1-C4=	0.0000	0.0000	0.0000	0.0000	0.0000	0.0000	0.0000
iso-C4=	0.0000	0.0000	0.0000	0.0000	0.0000	0.0000	0.0000
cis-C4=	0.0000	0.0000	0.0000	0.0000	0.0000	0.0000	0.0000
C5	0.0000	0.0000	0.0000	0.0000	0.0000	0.0000	0.0000
16.3200	0.0007	0.0009	0.0010	0.0008	0.0009	0.0009	0.0009
Benzene	8.8186	8.9094	8.9030	8.1480	8.1468	8.6343	8.7989
Toluene	0.0126	0.0016	0.0014	0.0012	0.0012	0.0011	0.0017
Et-Benzene	0.7094	0.6661	0.6595	0.6143	0.6165	0.6346	0.7464
m/p Xylene	0.0000	0.0000	0.0000	0.0000	0.0000	0.0000	0.0000
o-Xylene	0.0000	0.0000	0.0000	0.0000	0.0000	0.0000	0.0000
iPB	0.0205	0.0199	0.0185	0.0182	0.0182	0.0184	0.0202
PB	0.0004	0.0000	0.0000	0.0000	0.0000	0.0000	0.0000
Et-Toluene	0.0032	0.0010	0.0010	0.0008	0.0010	0.0010	0.0016
A	0.0013	0.0008	0.0004	0.0000	0.0000	0.0004	0.0005
B	0.0000	0.0000	0.0000	0.0000	0.0000	0.0000	0.0000
1,3-DEB	0.0094	0.0090	0.0081	0.0077	0.0078	0.0088	0.0106
1,4-DEB	0.0056	0.0053	0.0047	0.0046	0.0047	0.0050	0.0060
1,2-DEB	0.0000	0.0000	0.0000	0.0000	0.0000	0.0000	0.0004
TEB	0.0035	0.0000	0.0000	0.0000	0.0000	0.0000	0.0000
SUM DEB	0.0151	0.0142	0.0128	0.0124	0.0125	0.0138	0.0170
SUM Xyl	0.0000	0.0000	0.0000	0.0000	0.0000	0.0000	0.0000
Total	100.0000	100.0000	100.0000	100.0000	100.0000	100.0000	100.0000

Table: Mole%

Date: 19/05/08

Conversion of ethane-benzene over 0.025%Pt/HZSM5(72) catalyst at 370oC.

Feed: 90mol% ethane, 10mol% Benzene

Comments: TOS, cat. weight = 0.2000g

Feed flow: 8 ml/min 4 ml/min

6 ml/min

Experiment	605-ETH	606-ETH	606-ETH0	606-ETH0	607-ETH
Temper., °C	369	369	369	369	369
Tsat, oC	20.0	20.0	20.0	20.0	20.0
TOS, h	26.50	31.20	35.45	39.70	45.60
WHSV, h ⁻¹	3.80	1.95	7.75	7.75	2.80
Cont.time,h	0.2632	0.5128	0.1290	0.1290	0.3571
Conv. C2	1.323	1.497	1.064	1.027	1.349
Conv Benz	9.579	11.390	6.918	7.078	10.345
S1(E+B=E)	36.02	37.19	31.74	30.70	36.68
S2(B=EB)	94.73	94.36	95.16	95.15	94.83
S3(C2=)	10.04	7.76	15.62	16.25	9.36
S4 (H2)	51.41	51.98	50.72	51.17	51.35
S5 (DEBs)	2.24	1.86	1.81	1.77	2.09
S6 (TEB)	0.00	0.04	0.00	0.00	0.00
S7 (S2+S5)	96.97	96.27	96.96	96.91	96.92
Yield Et-Ben	9.074	10.748	6.583	6.735	9.810
H2	1.2302	1.4239	0.9725	0.9621	1.2587
C1	0.0000	0.0000	0.0000	0.0000	0.0000
C2	88.9316	88.7799	89.3976	90.0826	89.2525
C2=	0.2402	0.2125	0.2995	0.3055	0.2295
C3	0.0091	0.0198	0.0034	0.0036	0.0123
C3=	0.0017	0.0017	0.0015	0.0015	0.0019
i-C4	0.0000	0.0000	0.0000	0.0000	0.0000
n-C4	0.0010	0.0017	0.0000	0.0000	0.0000
trans -C4=	0.0000	0.0000	0.0000	0.0000	0.0000
1-C4=	0.0000	0.0000	0.0000	0.0000	0.0000
iso-C4=	0.0000	0.0000	0.0000	0.0000	0.0000
cis-C4=	0.0000	0.0000	0.0000	0.0000	0.0000
C5	0.0000	0.0000	0.0000	0.0000	0.0000
18.9170	0.0008	0.0000	0.0010	0.0009	0.0006
Benzene	8.6755	8.4807	8.6849	8.0370	8.2964
Toluene	0.0029	0.0105	0.0009	0.0009	0.0040
Et-Benzene	0.8620	1.0188	0.6086	0.5773	0.8990
m/p Xylene	0.0000	0.0008	0.0000	0.0000	0.0000
o-Xylene	0.0000	0.0000	0.0000	0.0000	0.0000
iPB	0.0224	0.0245	0.0177	0.0172	0.0223
PB	0.0000	0.0000	0.0000	0.0000	0.0000
Et-Toluene	0.0022	0.0044	0.0008	0.0006	0.0029
A	0.0000	0.0000	0.0000	0.0000	0.0000
B	0.0000	0.0000	0.0000	0.0000	0.0000
1,3-DEB	0.0128	0.0129	0.0073	0.0066	0.0130
1,4-DEB	0.0070	0.0065	0.0043	0.0041	0.0068
1,2-DEB	0.0006	0.0007	0.0000	0.0000	0.0000
TEB	0.0000	0.0005	0.0000	0.0000	0.0000
SUM DEB	0.0204	0.0201	0.0116	0.0107	0.0198
SUM Xyl	0.0000	0.0008	0.0000	0.0000	0.0000
Total	100.0000	100.0000	100.0000	100.0000	100.0000

A3.10. Concentrations (mol.%) of products produced over 0.1PtH-ZSM-5(72) catalyst at 370°C

Table: Mole%

Date: 27/04/08

Conversion of ethane-benzene over 0.1%Pt/HZSM5(72) catalyst at 370oC.

Feed: 90mol% ethane, 10mol% Benzene

Comments: TOS, cat. weight = 0.1000g

Feed flowrate = Ethane 16 ml/min

Experiment	571-ETH	572-ETH	572-ETH0	572-ETH0	572-ETH003
Temper., °C	368	368	368	368	368
Tsat, oC	20.0	20.0	20.0	20.0	20.0
TOS, h	1.00	4.25	8.50	12.75	20.00
WHSV, h ⁻¹	15.50	15.50	15.50	15.50	15.50
Cont.time, h	0.0645	0.0645	0.0645	0.0645	0.0645
Conv. C2	1.058	0.872	0.847	0.838	0.837
Conv Benz	4.885	4.186	4.064	4.148	4.031
S1(E+B=E)	25.97	24.66	24.21	23.42	24.47
S2(B=EB)	92.96	95.98	96.21	96.14	96.39
S3(C2=)	25.79	23.61	24.62	25.12	25.16
S4 (H2)	42.03	50.29	49.82	50.15	49.28
S5 (DEBs)	0.49	1.19	1.13	1.23	1.13
S6 (TEB)	0.00	0.00	0.00	0.00	0.00
S7 (S2+S5)	93.45	97.17	97.34	97.37	97.52
Yield Et-Be	4.541	4.018	3.910	3.988	3.885
H2	0.6969	0.7841	0.7509	0.7557	0.7298
C1	0.0339	0.0000	0.0000	0.0000	0.0000
C2	89.2587	89.2029	89.4688	89.9438	89.4999
C2=	0.4276	0.3681	0.3712	0.3785	0.3726
C3	0.0242	0.0021	0.0017	0.0016	0.0000
C3=	0.0072	0.0015	0.0014	0.0014	0.0013
i-C4	0.0000	0.0000	0.0000	0.0000	0.0000
n-C4	0.0028	0.0015	0.0016	0.0016	0.0000
trans -C4=	0.0000	0.0000	0.0000	0.0000	0.0000
1-C4=	0.0000	0.0000	0.0000	0.0000	0.0000
iso-C4=	0.0011	0.0000	0.0000	0.0000	0.0000
cis-C4=	0.0000	0.0000	0.0000	0.0000	0.0000
C5	0.0000	0.0000	0.0000	0.0000	0.0000
16.4540	0.0011	0.0012	0.0012	0.0011	0.0012
Benzene	9.0831	9.2381	9.0239	8.5492	9.0193
Toluene	0.0081	0.0006	0.0005	0.0005	0.0004
Et-Benzene	0.4306	0.3844	0.3650	0.3529	0.3624
m/p Xylene	0.0000	0.0000	0.0000	0.0000	0.0000
o-Xylene	0.0000	0.0000	0.0000	0.0000	0.0000
iPB	0.0171	0.0107	0.0096	0.0092	0.0090
PB	0.0012	0.0000	0.0000	0.0000	0.0000
Et-Toluene	0.0015	0.0000	0.0000	0.0000	0.0000
A	0.0024	0.0000	0.0000	0.0000	0.0000
B	0.0000	0.0000	0.0000	0.0000	0.0000
1,3-DEB	0.0023	0.0026	0.0024	0.0026	0.0022
1,4-DEB	0.0000	0.0022	0.0019	0.0019	0.0020
1,2-DEB	0.0000	0.0000	0.0000	0.0000	0.0000
TEB	0.0000	0.0000	0.0000	0.0000	0.0000
SUM DEB	0.0023	0.0048	0.0043	0.0045	0.0043
SUM Xyl	0.0000	0.0000	0.0000	0.0000	0.0000
Total	100.0000	100.0000	100.0000	100.0000	100.0000

Table: Mole%

Date: 27/04/08

Conversion of ethane-benzene over 0.1%Pt/HZSM5(72) catalyst at 370oC.

Feed: 90mol% ethane, 10mol% Benzene

Comments: TOS, cat. weight = 0.1000g

Feed flow: 32 ml/min 64 ml/min 96 ml/min 10 ml/min

Experiment	574-ETH	575-ETH	576-ETH	577-ETH	578-ETH
Temper., °C	368	367	365	368	369
Tsat, oC	20.0	20.0	20.0	20.0	20.0
TOS, h	22.00	24.00	25.25	26.25	27.92
WHSV, h ⁻¹	31.20	61.90	87.40	15.90	9.90
Cont.time,h	0.0321	0.0162	0.0114	0.0629	0.1010
Conv. C2	0.651	0.473	0.356	0.798	0.967
Conv Benz	1.901	0.751	0.400	3.712	5.556
S1(E+B=E)	15.08	7.89	5.25	23.71	29.64
S2(B=EB)	98.41	100.00	100.00	96.66	96.01
S3(C2=)	36.00	42.89	45.12	25.80	19.54
S4 (H2)	48.56	49.07	49.44	49.50	49.34
S5 (DEBs)	0.00	0.00	0.00	1.44	1.60
S6 (TEB)	0.00	0.00	0.00	0.00	0.00
S7 (S2+S5)	98.41	100.00	100.00	98.10	97.61
Yield Et-Be	1.871	0.751	0.400	3.588	5.334
H2	0.5565	0.4132	0.3163	0.7011	0.8401
C1	0.0000	0.0000	0.0000	0.0000	0.0000
C2	89.7406	90.3301	90.9534	89.4953	89.2847
C2=	0.4126	0.3612	0.2887	0.3654	0.3327
C3	0.0000	0.0000	0.0000	0.0000	0.0008
C3=	0.0000	0.0000	0.0000	0.0012	0.0017
i-C4	0.0000	0.0000	0.0000	0.0000	0.0000
n-C4	0.0000	0.0000	0.0000	0.0000	0.0007
trans -C4=	0.0000	0.0000	0.0000	0.0000	0.0000
1-C4=	0.0000	0.0000	0.0000	0.0000	0.0000
iso-C4=	0.0000	0.0000	0.0000	0.0000	0.0000
cis-C4=	0.0000	0.0000	0.0000	0.0000	0.0000
C5	0.0000	0.0000	0.0000	0.0000	0.0000
18.9170	0.0013	0.0013	0.0012	0.0012	0.0011
Benzene	9.1135	8.8277	8.4068	9.0882	9.0124
Toluene	0.0000	0.0000	0.0000	0.0000	0.0000
Et-Benzene	0.1728	0.0664	0.0336	0.3358	0.5047
m/p Xylene	0.0000	0.0000	0.0000	0.0000	0.0000
o-Xylene	0.0000	0.0000	0.0000	0.0000	0.0000
iPB	0.0028	0.0000	0.0000	0.0066	0.0126
PB	0.0000	0.0000	0.0000	0.0000	0.0000
Et-Toluene	0.0000	0.0000	0.0000	0.0000	0.0000
A	0.0000	0.0000	0.0000	0.0000	0.0000
B	0.0000	0.0000	0.0000	0.0000	0.0000
1,3-DEB	0.0000	0.0000	0.0000	0.0029	0.0051
1,4-DEB	0.0000	0.0000	0.0000	0.0021	0.0033
1,2-DEB	0.0000	0.0000	0.0000	0.0000	0.0000
TEB	0.0000	0.0000	0.0000	0.0000	0.0000
SUM DEB	0.0000	0.0000	0.0000	0.0050	0.0084
SUM Xyl	0.0000	0.0000	0.0000	0.0000	0.0000
Total	100.0000	100.0000	100.0000	100.0000	100.0000

Table: Mole%

Date: 06/05/08

Conversion of ethane-benzene over 0.1%Pt/HZSM5(72) catalyst at 370oC.

Feed: 90mol% ethane, 10mol% Benzene

Comments: TOS, cat. weight = 0.2016g

Feed flowrate = Ethane 16 ml/min

12 ml/min

Experiment	591-ETH	592-ETH	592-ETH0	592-ETH0	592-ETH0	593-ETH	594-ETH
Temper., °C	368	368	368	368	368	368	368
Tsat, oC	20.0	20.0	20.0	20.0	20.0	20.0	20.0
TOS, h	1.00	4.50	8.75	13.00	17.25	20.67	23.25
WHSV, h ⁻¹	7.54	7.69	7.69	7.69	7.69	7.54	5.65
Cont.time, h	0.1326	0.1300	0.1300	0.1300	0.1300	0.1326	0.1770
Conv. C2	1.443	1.161	1.180	1.175	1.155	1.169	1.251
Conv Benz	8.117	7.223	7.305	7.267	7.329	7.441	8.271
S1(E+B=E)	29.66	32.89	33.36	33.26	32.58	33.24	34.32
S2(B=EB)	88.15	94.23	94.37	94.43	94.35	94.17	94.37
S3(C2=)	11.32	13.20	12.91	13.11	13.33	13.37	11.32
S4 (H2)	46.49	50.97	51.11	51.06	51.54	50.78	51.70
S5 (DEBs)	1.91	1.79	1.86	1.77	1.88	2.01	2.03
S6 (TEB)	0.93	0.00	0.00	0.00	0.00	0.00	0.00
S7 (S2+S5)	90.99	96.02	96.23	96.20	96.23	96.18	96.40
Yield Et-Be	7.155	6.807	6.894	6.862	6.915	7.008	7.806
H2	1.1112	1.0576	1.0767	1.0710	1.0754	1.0570	1.1695
C1	0.1100	0.0035	0.0000	0.0000	0.0000	0.0000	0.0000
C2	88.3764	88.5384	88.3573	88.3873	88.7176	88.6932	88.5260
C2=	0.2704	0.2739	0.2720	0.2751	0.2782	0.2783	0.2560
C3	0.0818	0.0132	0.0107	0.0099	0.0096	0.0090	0.0116
C3=	0.0048	0.0010	0.0011	0.0012	0.0012	0.0012	0.0012
i-C4	0.0019	0.0000	0.0000	0.0000	0.0000	0.0000	0.0000
n-C4	0.0048	0.0013	0.0011	0.0010	0.0010	0.0009	0.0010
trans -C4=	0.0000	0.0000	0.0000	0.0000	0.0000	0.0000	0.0000
1-C4=	0.0000	0.0000	0.0000	0.0000	0.0000	0.0000	0.0000
iso-C4=	0.0009	0.0000	0.0000	0.0000	0.0000	0.0000	0.0000
cis-C4=	0.0000	0.0000	0.0000	0.0000	0.0000	0.0000	0.0000
C5	0.0000	0.0000	0.0000	0.0000	0.0000	0.0000	0.0000
16.4060	0.0000	0.0000	0.0005	0.0006	0.0006	0.0006	0.0000
Benzene	9.2336	9.3869	9.5358	9.5151	9.1958	9.2253	9.2120
Toluene	0.0378	0.0035	0.0026	0.0024	0.0023	0.0022	0.0028
Et-Benzene	0.7089	0.6825	0.7028	0.6977	0.6799	0.6918	0.7764
m/p Xylene	0.0007	0.0000	0.0000	0.0000	0.0000	0.0000	0.0000
o-Xylene	0.0000	0.0000	0.0000	0.0000	0.0000	0.0000	0.0000
iPB	0.0232	0.0242	0.0244	0.0242	0.0238	0.0243	0.0254
PB	0.0008	0.0000	0.0000	0.0000	0.0000	0.0000	0.0000
Et-Toluene	0.0045	0.0011	0.0011	0.0011	0.0010	0.0012	0.0014
A	0.0043	0.0000	0.0000	0.0000	0.0000	0.0004	0.0000
B	0.0012	0.0000	0.0000	0.0004	0.0000	0.0000	0.0000
1,3-DEB	0.0096	0.0084	0.0088	0.0083	0.0086	0.0093	0.0108
1,4-DEB	0.0058	0.0046	0.0051	0.0048	0.0050	0.0055	0.0059
1,2-DEB	0.0000	0.0000	0.0000	0.0000	0.0000	0.0000	0.0000
TEB	0.0075	0.0000	0.0000	0.0000	0.0000	0.0000	0.0000
SUM DEB	0.0153	0.0130	0.0138	0.0131	0.0136	0.0148	0.0167
SUM Xyl	0.0007	0.0000	0.0000	0.0000	0.0000	0.0000	0.0000
Total	100.0000	100.0000	100.0000	100.0000	100.0000	100.0000	100.0000

Table: Mole%

Date: 06/05/08

Conversion of ethane-benzene over 0.1%Pt/HZSM5(72) catalyst at 370oC.

Feed: 90mol% ethane, 10mol% Benzene

Comments: TOS, cat. weight = 0.2016g

Feed flow: 8 ml/min 4 ml/min

6 ml/min

Experiment	595-ETH	596-ETH	596-ETH0	596-ETH0	597-ETH
Temper., °C	368	369	369	368	368
Tsat, oC	20.0	21.0	20.0	20.0	20.0
TOS, h	26.43	31.00	35.25	39.50	46.33
WHSV, h ⁻¹	3.82	1.74	7.54	7.54	2.93
Cont.time,h	0.2618	0.5747	0.1326	0.1326	0.3413
Conv. C2	1.390	1.544	1.120	1.141	1.453
Conv Benz	9.732	11.191	6.921	6.992	10.544
S1(E+B=E)	36.12	35.69	32.88	32.76	36.78
S2(B=EB)	94.34	93.74	94.80	94.44	94.19
S3(C2=)	9.14	6.63	14.12	14.12	8.48
S4 (H2)	51.81	53.62	50.66	50.69	51.65
S5 (DEBs)	1.96	1.95	1.50	1.79	2.10
S6 (TEB)	0.16	0.24	0.00	0.00	0.19
S7 (S2+S5)	96.47	95.93	96.31	96.23	96.48
Yield Et-Be	9.181	10.490	6.562	6.603	9.931
H2	1.3022	1.5391	1.0105	1.0279	1.3542
C1	0.0000	0.0054	0.0000	0.0000	0.0000
C2	88.4687	88.3639	88.6217	88.5297	88.5989
C2=	0.2296	0.1903	0.2818	0.2864	0.2224
C3	0.0168	0.0386	0.0079	0.0075	0.0187
C3=	0.0012	0.0016	0.0012	0.0012	0.0014
i-C4	0.0000	0.0008	0.0000	0.0000	0.0000
n-C4	0.0012	0.0018	0.0009	0.0008	0.0012
trans -C4=	0.0000	0.0000	0.0000	0.0000	0.0000
1-C4=	0.0000	0.0000	0.0000	0.0000	0.0000
iso-C4=	0.0000	0.0000	0.0000	0.0000	0.0000
cis-C4=	0.0000	0.0000	0.0000	0.0000	0.0000
C5	0.0000	0.0000	0.0000	0.0000	0.0000
18.9170	0.0000	0.0000	0.0007	0.0007	0.0000
Benzene	9.0180	8.7656	9.3835	9.4423	8.7793
Toluene	0.0046	0.0118	0.0019	0.0017	0.0060
Et-Benzene	0.9079	1.0245	0.6559	0.6643	0.9644
m/p Xylene	0.0000	0.0010	0.0000	0.0000	0.0000
o-Xylene	0.0000	0.0004	0.0000	0.0000	0.0000
iPB	0.0271	0.0266	0.0232	0.0237	0.0273
PB	0.0000	0.0000	0.0000	0.0000	0.0000
Et-Toluene	0.0024	0.0041	0.0005	0.0011	0.0028
A	0.0000	0.0006	0.0000	0.0000	0.0000
B	0.0000	0.0000	0.0000	0.0000	0.0000
1,3-DEB	0.0128	0.0135	0.0066	0.0078	0.0141
1,4-DEB	0.0061	0.0069	0.0038	0.0048	0.0074
1,2-DEB	0.0000	0.0009	0.0000	0.0000	0.0000
TEB	0.0016	0.0026	0.0000	0.0000	0.0020
SUM DEB	0.0189	0.0213	0.0104	0.0126	0.0215
SUM Xyl	0.0000	0.0014	0.0000	0.0000	0.0000
Total	100.0000	100.0000	100.0000	100.0000	100.0000

A3.11. Concentrations (mol.%) of products produced over 0.5PtH-ZSM-5(72) catalyst at 370°C

Table: Mole%

Date: 11/08/07

Conversion of ethane-benzene over 0.5%Pt/HZSM5(72) catalyst at 370oC.

Feed: 90mol% ethane, 10mol% Benzene

Comments: TOS, cat. weight = 0.1007g

Feed flowrate = Ethane 16 ml/min

32 ml/min

Experiment	441-ETH	442-ETH	442-ETH0	442-ETH0	442-ETH0	443-ETH	444-ETH
Temper., °C	369	368	368	368	368	368	368
Tsat, oC	20.0	20.0	20.0	20.0	20.0	20.0	20.0
TOS, h	1.00	4.00	8.25	12.50	16.75	20.50	22.25
WHSV, h ⁻¹	15.10	15.39	15.39	15.39	15.39	15.49	31.78
Cont.time,h	0.0662	0.0650	0.0650	0.0650	0.0650	0.0646	0.0315
Conv. C2	0.991	0.966	0.953	0.961	0.936	0.927	0.766
Conv Benz	5.306	5.065	4.896	4.900	4.748	4.777	2.733
S1(E+B=E)	27.32	27.05	26.84	26.48	26.22	25.73	17.34
S2(B=EB)	93.28	93.71	94.11	93.87	94.08	94.05	94.62
S3(C2=)	19.64	20.40	21.16	20.85	21.74	22.11	32.01
S4 (H2)	49.74	50.16	49.79	50.43	49.88	50.03	49.42
S5 (DEBs)	1.86	1.79	1.37	1.59	1.34	1.35	0.68
S6 (TEB)	0.00	0.00	0.00	0.00	0.00	0.00	0.00
S7 (S2+S5)	95.13	95.50	95.48	95.46	95.43	95.41	95.30
Yield Et-Be	4.949	4.746	4.608	4.600	4.468	4.493	2.586
H2	0.8656	0.8554	0.8347	0.8600	0.8236	0.8225	0.6712
C1	0.0070	0.0000	0.0000	0.0000	0.0000	0.0000	0.0000
C2	89.0773	88.9840	88.9619	88.8787	89.0443	89.3190	89.7238
C2=	0.3417	0.3479	0.3547	0.3555	0.3589	0.3635	0.4348
C3	0.0124	0.0070	0.0062	0.0059	0.0056	0.0054	0.0020
C3=	0.0017	0.0011	0.0011	0.0011	0.0010	0.0010	0.0000
i-C4	0.0000	0.0000	0.0000	0.0000	0.0000	0.0000	0.0000
n-C4	0.0012	0.0009	0.0008	0.0008	0.0008	0.0008	0.0000
trans -C4=	0.0000	0.0000	0.0000	0.0000	0.0000	0.0000	0.0000
1-C4=	0.0000	0.0000	0.0000	0.0000	0.0000	0.0000	0.0000
iso-C4=	0.0000	0.0000	0.0000	0.0000	0.0000	0.0000	0.0000
cis-C4=	0.0000	0.0000	0.0000	0.0000	0.0000	0.0000	0.0000
C5	0.0000	0.0000	0.0000	0.0000	0.0000	0.0000	0.0000
16.4330	0.0008	0.0009	0.0010	0.0010	0.0010	0.0010	0.0012
Benzene	9.1825	9.3106	9.3616	9.4160	9.3046	9.0372	8.9181
Toluene	0.0034	0.0016	0.0014	0.0013	0.0012	0.0012	0.0006
Et-Benzene	0.4755	0.4613	0.4499	0.4516	0.4329	0.4230	0.2356
m/p Xylene	0.0000	0.0000	0.0000	0.0000	0.0000	0.0000	0.0000
o-Xylene	0.0000	0.0000	0.0000	0.0000	0.0000	0.0000	0.0000
iPB	0.0196	0.0200	0.0197	0.0201	0.0194	0.0190	0.0111
PB	0.0000	0.0000	0.0000	0.0000	0.0000	0.0000	0.0000
Et-Toluene	0.0012	0.0005	0.0005	0.0005	0.0004	0.0005	0.0000
A	0.0006	0.0000	0.0000	0.0000	0.0000	0.0000	0.0000
B	0.0000	0.0000	0.0000	0.0000	0.0000	0.0000	0.0000
1,3-DEB	0.0057	0.0052	0.0041	0.0046	0.0035	0.0036	0.0010
1,4-DEB	0.0038	0.0036	0.0024	0.0030	0.0027	0.0025	0.0007
1,2-DEB	0.0000	0.0000	0.0000	0.0000	0.0000	0.0000	0.0000
TEB	0.0000	0.0000	0.0000	0.0000	0.0000	0.0000	0.0000
SUM DEB	0.0095	0.0088	0.0065	0.0077	0.0062	0.0061	0.0017
SUM Xyl	0.0000	0.0000	0.0000	0.0000	0.0000	0.0000	0.0000
Total	100.0000	100.0000	100.0000	100.0000	100.0000	100.0000	100.0000

Table: Mole%

Date: 11/08/07

Conversion of ethane-benzene over 0.5%Pt/HZSM5(72) catalyst at 370oC.

Feed: 90mol% ethane, 10mol% Benzene

Comments: TOS, cat. weight = 0.1007g

Feed flow: 96 ml/min 64 ml/min 8 ml/min

Experiment	445-ETH	446-ETH	447-ETH
Temper., °C	366	366	369
Tsat, oC	20.0	20.0	20.0
TOS, h	24.00	25.67	27.25
WHSV, h ⁻¹	95.73	62.46	7.65
Cont.time, h	0.0104	0.0160	0.1307
Conv. C2	0.585	0.643	1.127
Conv Benz	0.908	1.372	7.200
S1(E+B=E)	6.87	10.05	32.14
S2(B=EB)	97.32	97.03	93.85
S3(C2=)	43.27	40.40	14.94
S4 (H2)	49.55	49.13	50.15
S5 (DEBs)	0.00	0.00	2.03
S6 (TEB)	0.00	0.00	0.00
S7 (S2+S5)	97.32	97.03	95.88
Yield Et-Be	0.884	1.331	6.757
H2	0.5226	0.5629	0.9987
C1	0.0000	0.0000	0.0000
C2	90.7731	90.2800	89.1337
C2=	0.4564	0.4629	0.2974
C3	0.0000	0.0000	0.0105
C3=	0.0000	0.0000	0.0012
i-C4	0.0000	0.0000	0.0000
n-C4	0.0000	0.0000	0.0008
trans -C4=	0.0000	0.0000	0.0000
1-C4=	0.0000	0.0000	0.0000
iso-C4=	0.0000	0.0000	0.0000
cis-C4=	0.0000	0.0000	0.0000
C5	0.0000	0.0000	0.0000
18.9170	0.0013	0.0013	0.0008
Benzene	8.1722	8.5742	8.8748
Toluene	0.0000	0.0000	0.0023
Et-Benzene	0.0725	0.1151	0.6401
m/p Xylene	0.0000	0.0000	0.0000
o-Xylene	0.0000	0.0000	0.0000
iPB	0.0020	0.0035	0.0241
PB	0.0000	0.0000	0.0000
Et-Toluene	0.0000	0.0000	0.0013
A	0.0000	0.0000	0.0004
B	0.0000	0.0000	0.0000
1,3-DEB	0.0000	0.0000	0.0089
1,4-DEB	0.0000	0.0000	0.0050
1,2-DEB	0.0000	0.0000	0.0000
TEB	0.0000	0.0000	0.0000
SUM DEB	0.0000	0.0000	0.0139
SUM Xyl	0.0000	0.0000	0.0000
Total	100.0000	100.0000	100.0000

Table: Mole%

Date: 25/08/07

Conversion of ethane-benzene over 0.5%Pt/HZSM5(72) catalyst at 370oC.

Feed: 90mol% ethane, 10mol% Benzene

Comments: TOS, cat. weight = 0.5014g

Feed flowrate = Ethane 16 ml/min

24 ml/min

Experiment	471-ETH	472-ETH	472-ETH0	472-ETH0	472-ETH0	473-ETH	474-ETH
Temper., °C	369	369	369	369	369	369	369
Tsat, oC	19.5	20.0	20.0	20.0	20.0	20.5	19.5
TOS, h	1.00	4.00	8.25	12.50	16.75	20.25	23.25
WHSV, h ⁻¹	3.03	3.09	3.09	3.09	3.09	3.05	4.71
Cont.time, h	0.3300	0.3236	0.3236	0.3236	0.3236	0.3279	0.2123
Conv. C2	3.304	2.732	2.422	2.125	1.942	1.787	1.530
Conv Benz	13.449	12.835	12.171	11.525	11.514	11.744	10.350
S1(E+B=E)	18.63	24.28	27.38	29.63	31.76	32.64	34.16
S2(B=EB)	71.78	80.50	84.21	86.59	88.28	89.71	91.83
S3(C2=)	4.03	4.64	4.98	5.31	5.47	5.84	7.39
S4 (H2)	25.31	31.01	34.74	38.99	43.02	45.74	48.34
S5 (DEBs)	1.70	1.90	1.81	1.81	1.90	1.94	1.94
S6 (TEB)	1.78	0.99	0.66	0.30	0.33	0.35	0.21
S7 (S2+S5)	75.26	83.39	86.68	88.69	90.51	92.00	93.98
Yield Et-Be	9.654	10.332	10.249	9.979	10.164	10.536	9.504
H2	1.2289	1.2809	1.3053	1.3345	1.3909	1.4043	1.2945
C1	1.7414	1.1125	0.8126	0.5602	0.3695	0.2595	0.1223
C2	86.8826	87.2814	87.3137	87.4879	87.7276	88.4399	88.6006
C2=	0.1955	0.1917	0.1870	0.1816	0.1768	0.1794	0.1980
C3	0.3924	0.2718	0.2075	0.1555	0.1166	0.0957	0.0574
C3=	0.0139	0.0095	0.0071	0.0052	0.0038	0.0031	0.0022
i-C4	0.0066	0.0049	0.0042	0.0035	0.0030	0.0026	0.0016
n-C4	0.0132	0.0112	0.0101	0.0088	0.0078	0.0070	0.0056
trans -C4=	0.0010	0.0008	0.0007	0.0007	0.0007	0.0007	0.0000
1-C4=	0.0000	0.0000	0.0000	0.0000	0.0000	0.0000	0.0000
iso-C4=	0.0019	0.0015	0.0013	0.0011	0.0009	0.0009	0.0000
cis-C4=	0.0000	0.0000	0.0000	0.0000	0.0000	0.0000	0.0000
C5	0.0000	0.0000	0.0000	0.0000	0.0000	0.0000	0.0000
18.9170	0.0000	0.0000	0.0000	0.0000	0.0000	0.0000	0.0000
Benzene	8.2622	8.5879	8.9289	9.0898	9.0394	8.4897	8.7215
Toluene	0.2455	0.1509	0.1152	0.0905	0.0710	0.0564	0.0284
Et-Benzene	0.9047	1.0030	1.0287	1.0140	1.0267	1.0022	0.9148
m/p Xylene	0.0063	0.0037	0.0028	0.0023	0.0019	0.0016	0.0007
o-Xylene	0.0019	0.0012	0.0010	0.0009	0.0006	0.0005	0.0000
iPB	0.0187	0.0224	0.0231	0.0229	0.0234	0.0231	0.0234
PB	0.0000	0.0018	0.0014	0.0008	0.0007	0.0004	0.0000
Et-Toluene	0.0170	0.0129	0.0096	0.0077	0.0069	0.0053	0.0040
A	0.0211	0.0132	0.0097	0.0074	0.0059	0.0020	0.0035
B	0.0014	0.0008	0.0000	0.0000	0.0000	0.0000	0.0000
1,3-DEB	0.0133	0.0150	0.0141	0.0135	0.0141	0.0139	0.0127
1,4-DEB	0.0074	0.0080	0.0075	0.0071	0.0074	0.0072	0.0066
1,2-DEB	0.0007	0.0007	0.0005	0.0006	0.0006	0.0006	0.0000
TEB	0.0224	0.0124	0.0080	0.0035	0.0038	0.0039	0.0021
SUM DEB	0.0214	0.0236	0.0221	0.0212	0.0221	0.0216	0.0194
SUM Xyl	0.0082	0.0049	0.0037	0.0032	0.0026	0.0021	0.0007
Total	100.0000	100.0000	100.0000	100.0000	100.0000	100.0000	100.0000

Table: Mole%

Date: 25/08/07

Conversion of ethane-benzene over 0.5%Pt/HZSM5(72) catalyst at 370oC.

Feed: 90mol% ethane, 10mol% Benzene

Comments: TOS, cat. weight = 0.5014g

Feed flow: 8 ml/min 32 ml/min

Experiment	475-ETH	476-ETH	476-ETH0	476-ETH0	476-ETH003
Temper., °C	369	368	369	369	369
Tsat, oC	20.0	20.0	20.0	20.0	20.0
TOS, h	26.25	29.25	33.50	37.75	42.00
WHSV, h ⁻¹	1.50	6.32	3.05	3.05	3.05
Cont.time,h	0.6667	0.1582	0.3279	0.3279	0.3279
Conv. C2	2.007	1.309	1.541	1.547	1.463
Conv Benz	13.415	9.144	11.455	12.008	11.920
S1(E+B=E)	33.11	35.18	36.48	38.16	37.53
S2(B=EB)	87.17	93.47	93.13	93.50	93.88
S3(C2=)	4.43	9.48	6.33	6.57	6.90
S4 (H2)	46.57	49.41	51.16	50.28	51.22
S5 (DEBs)	1.87	2.01	1.94	2.01	2.05
S6 (TEB)	0.77	0.00	0.33	0.23	0.21
S7 (S2+S5)	89.81	95.49	95.40	95.73	96.14
Yield Et-Be	11.694	8.548	10.668	11.226	11.191
H2	1.6081	1.1400	1.4210	1.3779	1.3529
C1	0.2553	0.0430	0.0426	0.0205	0.0106
C2	87.9692	88.9818	88.7169	88.9751	89.4733
C2=	0.1530	0.2188	0.1757	0.1800	0.1822
C3	0.1105	0.0311	0.0443	0.0386	0.0355
C3=	0.0031	0.0014	0.0014	0.0013	0.0012
i-C4	0.0034	0.0009	0.0012	0.0011	0.0009
n-C4	0.0067	0.0035	0.0034	0.0025	0.0020
trans -C4=	0.0005	0.0000	0.0000	0.0000	0.0000
1-C4=	0.0000	0.0000	0.0000	0.0000	0.0000
iso-C4=	0.0008	0.0000	0.0000	0.0000	0.0000
cis-C4=	0.0000	0.0000	0.0000	0.0000	0.0000
C5	0.0000	0.0000	0.0000	0.0000	0.0000
18.9170	0.0000	0.0000	0.0000	0.0000	0.0000
Benzene	8.5779	8.7112	8.5053	8.2847	7.8856
Toluene	0.0872	0.0131	0.0204	0.0149	0.0112
Et-Benzene	1.1431	0.8117	1.0135	1.0456	0.9913
m/p Xylene	0.0035	0.0000	0.0009	0.0008	0.0008
o-Xylene	0.0012	0.0000	0.0000	0.0000	0.0000
iPB	0.0232	0.0231	0.0238	0.0251	0.0242
PB	0.0006	0.0000	0.0000	0.0000	0.0000
Et-Toluene	0.0105	0.0021	0.0040	0.0044	0.0038
A	0.0071	0.0009	0.0010	0.0025	0.0007
B	0.0004	0.0000	0.0000	0.0000	0.0000
1,3-DEB	0.0153	0.0114	0.0138	0.0147	0.0141
1,4-DEB	0.0078	0.0060	0.0067	0.0072	0.0072
1,2-DEB	0.0014	0.0000	0.0006	0.0006	0.0005
TEB	0.0101	0.0000	0.0036	0.0026	0.0022
SUM DEB	0.0245	0.0175	0.0211	0.0225	0.0217
SUM Xyl	0.0047	0.0000	0.0009	0.0008	0.0008
Total	100.0000	100.0000	100.0000	100.0000	100.0000

A3.12. Concentrations (mol.%) of products produced over 1PtH-ZSM-5(72) catalyst at 370°C

Table: Mole%

Date: 02/08/07

Conversion of ethane-benzene over 1%Pt/HZSM5(72) catalyst at 370oC.

Feed: 90mol% ethane, 10mol% Benzene

Comments: TOS, cat. weight = 0.1007g

Feed flowrate = Ethane 16 ml/min

Experiment	421-ETH	422-ETH	422-ETH0	422-ETH0	422-ETH0	423-ETH
Temper., °C	369	369	369	369	369	369
Tsat, oC	20.0	20.0	20.0	20.0	20.0	20.0
TOS, h	1.00	4.00	8.25	12.50	16.75	20.00
WHSV, h ⁻¹	15.09	15.49	15.49	15.49	15.49	15.09
Cont.time,h	0.0663	0.0646	0.0646	0.0646	0.0646	0.0663
Conv. C2	0.956	0.963	0.954	0.952	0.924	0.941
Conv Benz	5.160	5.051	4.886	5.021	4.874	4.869
S1(E+B=E)	26.66	27.07	26.65	26.32	26.14	26.24
S2(B=EB)	93.91	94.12	94.59	93.76	94.21	94.17
S3(C2=)	19.87	20.83	20.85	21.34	22.24	21.72
S4 (H2)	50.90	49.93	50.54	50.17	49.59	50.01
S5 (DEBs)	1.55	1.41	0.99	1.81	1.39	1.44
S6 (TEB)	0.00	0.00	0.00	0.00	0.00	0.00
S7 (S2+S5)	95.46	95.53	95.57	95.58	95.59	95.61
Yield Et-Be	4.846	4.754	4.621	4.707	4.591	4.585
H2	0.8755	0.8495	0.8620	0.8477	0.8090	0.8344
C1	0.0032	0.0000	0.0000	0.0000	0.0000	0.0000
C2	89.2283	89.0246	88.8716	89.2556	89.4620	89.1721
C2=	0.3417	0.3544	0.3556	0.3606	0.3628	0.3624
C3	0.0082	0.0061	0.0053	0.0051	0.0048	0.0046
C3=	0.0014	0.0011	0.0011	0.0011	0.0011	0.0011
i-C4	0.0000	0.0000	0.0000	0.0000	0.0000	0.0000
n-C4	0.0008	0.0000	0.0000	0.0000	0.0000	0.0000
trans -C4=	0.0000	0.0000	0.0000	0.0000	0.0000	0.0000
1-C4=	0.0000	0.0000	0.0000	0.0000	0.0000	0.0000
iso-C4=	0.0000	0.0000	0.0000	0.0000	0.0000	0.0000
cis-C4=	0.0000	0.0000	0.0000	0.0000	0.0000	0.0000
C5	0.0000	0.0000	0.0000	0.0000	0.0000	0.0000
16.3240	0.0008	0.0009	0.0010	0.0010	0.0010	0.0010
Benzene	9.0519	9.2741	9.4229	9.0546	8.9067	9.1594
Toluene	0.0023	0.0018	0.0015	0.0013	0.0012	0.0012
Et-Benzene	0.4585	0.4605	0.4544	0.4448	0.4264	0.4378
m/p Xylene	0.0000	0.0000	0.0000	0.0000	0.0000	0.0000
o-Xylene	0.0000	0.0000	0.0000	0.0000	0.0000	0.0000
iPB	0.0185	0.0196	0.0193	0.0192	0.0183	0.0188
PB	0.0000	0.0000	0.0000	0.0000	0.0000	0.0000
Et-Toluene	0.0009	0.0005	0.0004	0.0004	0.0004	0.0004
A	0.0005	0.0000	0.0000	0.0000	0.0000	0.0000
B	0.0000	0.0000	0.0000	0.0000	0.0000	0.0000
1,3-DEB	0.0045	0.0041	0.0024	0.0050	0.0036	0.0039
1,4-DEB	0.0030	0.0028	0.0024	0.0036	0.0027	0.0028
1,2-DEB	0.0000	0.0000	0.0000	0.0000	0.0000	0.0000
TEB	0.0000	0.0000	0.0000	0.0000	0.0000	0.0000
SUM DEB	0.0075	0.0069	0.0047	0.0086	0.0063	0.0067
SUM Xyl	0.0000	0.0000	0.0000	0.0000	0.0000	0.0000
Total	100.0000	100.0000	100.0000	100.0000	100.0000	100.0000

Table: Mole%

Date: 02/08/07

Conversion of ethane-benzene over 1%Pt/HZSM5(72) catalyst at 370oC.

Feed: 90mol% ethane, 10mol% Benzene

Comments: TOS, cat. weight = 0.1007g

Feed flow: 32 ml/min 64 ml/min 96 ml/min

Experiment	424-ETH	425-ETH	426-ETH
Temper., °C	369	368	367
Tsat, oC	20.0	20.0	20.0
TOS, h	22.00	23.93	25.83
WHSV, h ⁻¹	31.18	63.46	93.35
Cont.time,h	0.0321	0.0158	0.0107
Conv. C2	0.787	0.656	0.589
Conv Benz	2.727	1.414	0.915
S1(E+B=E)	18.44	10.30	7.18
S2(B=EB)	94.92	96.87	97.52
S3(C2=)	30.85	39.84	42.92
S4 (H2)	49.51	49.43	49.60
S5 (DEBs)	0.71	0.00	0.00
S6 (TEB)	0.00	0.00	0.00
S7 (S2+S5)	95.63	96.87	97.52
Yield Et-Be	2.589	1.370	0.892
H2	0.6866	0.5801	0.5261
C1	0.0000	0.0000	0.0000
C2	88.9374	90.0814	90.4375
C2=	0.4279	0.4675	0.4551
C3	0.0016	0.0000	0.0000
C3=	0.0000	0.0000	0.0000
i-C4	0.0000	0.0000	0.0000
n-C4	0.0000	0.0000	0.0000
trans -C4=	0.0000	0.0000	0.0000
1-C4=	0.0000	0.0000	0.0000
iso-C4=	0.0000	0.0000	0.0000
cis-C4=	0.0000	0.0000	0.0000
C5	0.0000	0.0000	0.0000
18.9170	0.0013	0.0013	0.0013
Benzene	9.6758	8.7449	8.5019
Toluene	0.0007	0.0000	0.0000
Et-Benzene	0.2558	0.1209	0.0761
m/p Xylene	0.0000	0.0000	0.0000
o-Xylene	0.0000	0.0000	0.0000
iPB	0.0111	0.0039	0.0019
PB	0.0000	0.0000	0.0000
Et-Toluene	0.0000	0.0000	0.0000
A	0.0000	0.0000	0.0000
B	0.0000	0.0000	0.0000
1,3-DEB	0.0007	0.0000	0.0000
1,4-DEB	0.0012	0.0000	0.0000
1,2-DEB	0.0000	0.0000	0.0000
TEB	0.0000	0.0000	0.0000
SUM DEB	0.0019	0.0000	0.0000
SUM Xyl	0.0000	0.0000	0.0000
Total	100.0000	100.0000	100.0000

Table: Mole%

Date: 07/08/07

Conversion of ethane-benzene over 1%Pt/HZSM5(72) catalyst at 370oC.

Feed: 90mol% ethane, 10mol% Benzene

Comments: TOS, cat. weight = 0.5054g

Feed flowrate = Ethane 16 ml/min

32 ml/min

Experiment	431-ETH	432-ETH	432-ETH0	432-ETH0	432-ETH0	433-ETH	434-ETH
Temper., °C	369	369	369	369	369	368	368
Tsat, oC	20.0	20.0	20.0	20.0	20.0	20.0	20.0
TOS, h	1.00	4.00	8.25	12.50	16.75	20.50	23.33
WHSV, h ⁻¹	3.03	2.99	2.99	2.99	2.99	3.07	6.39
Cont.time, h	0.3300	0.3344	0.3344	0.3344	0.3344	0.3257	0.1565
Conv. C2	1.927	1.785	1.712	1.579	1.506	1.544	1.284
Conv Benz	11.426	11.379	11.626	11.598	11.698	11.465	9.300
S1(E+B=E)	28.93	32.53	34.34	35.50	36.09	36.95	35.10
S2(B=EB)	84.87	89.22	90.91	91.95	93.04	93.04	93.75
S3(C2=)	5.55	5.91	6.21	6.80	7.05	6.83	10.26
S4 (H2)	46.53	48.49	49.86	50.52	51.69	51.62	51.20
S5 (DEBs)	1.80	1.94	2.02	2.03	2.12	2.13	2.19
S6 (TEB)	2.62	1.38	1.01	0.85	0.45	0.73	0.24
S7 (S2+S5)	89.30	92.54	93.94	94.82	95.61	95.90	96.18
Yield Et-Be	9.698	10.153	10.569	10.663	10.883	10.668	8.719
H2	1.5244	1.5030	1.5020	1.4130	1.4068	1.4218	1.1794
C1	0.3208	0.1908	0.1132	0.0565	0.0203	0.0094	0.0036
C2	87.8771	87.9557	88.2106	88.8584	89.2114	88.6846	89.1918
C2=	0.1820	0.1832	0.1871	0.1902	0.1918	0.1882	0.2363
C3	0.1170	0.0813	0.0631	0.0503	0.0420	0.0373	0.0193
C3=	0.0041	0.0028	0.0023	0.0019	0.0015	0.0013	0.0010
i-C4	0.0031	0.0022	0.0016	0.0014	0.0011	0.0009	0.0000
n-C4	0.0075	0.0063	0.0049	0.0036	0.0025	0.0018	0.0013
trans -C4=	0.0000	0.0000	0.0000	0.0000	0.0000	0.0000	0.0000
1-C4=	0.0000	0.0000	0.0000	0.0000	0.0000	0.0000	0.0000
iso-C4=	0.0000	0.0000	0.0000	0.0000	0.0000	0.0000	0.0000
cis-C4=	0.0008	0.0000	0.0000	0.0000	0.0000	0.0000	0.0000
C5	0.0000	0.0000	0.0000	0.0000	0.0000	0.0000	0.0000
18.9170	0.0000	0.0000	0.0000	0.0000	0.0000	0.0000	0.0000
Benzene	8.8465	8.9445	8.7773	8.3450	8.0668	8.5609	8.5047
Toluene	0.0778	0.0456	0.0310	0.0210	0.0140	0.0108	0.0043
Et-Benzene	0.9477	1.0083	1.0345	0.9928	0.9823	1.0178	0.8086
m/p Xylene	0.0023	0.0016	0.0012	0.0009	0.0008	0.0007	0.0000
o-Xylene	0.0005	0.0005	0.0004	0.0000	0.0000	0.0000	0.0000
iPB	0.0222	0.0249	0.0263	0.0256	0.0259	0.0266	0.0261
PB	0.0007	0.0000	0.0000	0.0000	0.0000	0.0000	0.0000
Et-Toluene	0.0065	0.0052	0.0046	0.0041	0.0035	0.0047	0.0018
A	0.0060	0.0049	0.0039	0.0031	0.0009	0.0009	0.0004
B	0.0034	0.0016	0.0014	0.0012	0.0012	0.0011	0.0004
1,3-DEB	0.0128	0.0138	0.0146	0.0140	0.0142	0.0148	0.0124
1,4-DEB	0.0066	0.0071	0.0075	0.0072	0.0072	0.0075	0.0065
1,2-DEB	0.0008	0.0009	0.0009	0.0008	0.0009	0.0009	0.0000
TEB	0.0293	0.0156	0.0115	0.0092	0.0048	0.0080	0.0021
SUM DEB	0.0201	0.0219	0.0230	0.0219	0.0224	0.0233	0.0189
SUM Xyl	0.0029	0.0021	0.0016	0.0009	0.0008	0.0007	0.0000
Total	100.0000	100.0000	100.0000	100.0000	100.0000	100.0000	100.0000

Table: Mole%

Date: 07/08/07

Conversion of ethane-benzene over 1%Pt/HZSM5(72) catalyst at 370oC.

Feed: 90mol% ethane, 10mol% Benzene

Comments: TOS, cat. weight = 0.5054g

Feed flowr: 24 ml/min

8 ml/min 48 ml/min

Experiment	435-ETH	435-ETH0	435-ETH0	435-ETH0	436-ETH	437-ETH
Temper., °C	368	369	369	369	369	367
Tsat, oC	20.0	20.0	20.0	20.0	20.0	20.0
TOS, h	26.25	30.50	34.75	39.00	45.00	48.00
WHSV, h ⁻¹	4.67	3.07	3.07	3.07	1.48	9.22
Cont.time,h	0.2141	0.3257	0.3257	0.3257	0.6757	0.1085
Conv. C2	1.414	1.575	1.566	1.535	1.736	1.121
Conv Benz	10.207	11.380	11.643	11.783	12.637	7.617
S1(E+B=E)	37.04	37.76	37.33	37.28	36.36	32.53
S2(B=EB)	93.56	93.48	93.48	93.64	92.15	93.90
S3(C2=)	8.52	6.74	6.79	7.01	5.25	13.89
S4 (H2)	50.61	51.25	51.70	51.59	52.88	50.89
S5 (DEBs)	2.15	2.12	2.17	2.18	2.00	2.14
S6 (TEB)	0.42	0.62	0.55	0.37	1.14	0.00
S7 (S2+S5)	96.13	96.22	96.21	96.19	95.29	96.04
Yield Et-Be	9.550	10.638	10.884	11.034	11.645	7.152
H2	1.2602	1.4290	1.4496	1.4235	1.6558	1.0253
C1	0.0046	0.0070	0.0066	0.0065	0.0130	0.0000
C2	88.7318	88.3278	88.5911	88.9192	88.1943	89.4361
C2=	0.2123	0.1881	0.1903	0.1933	0.1646	0.2799
C3	0.0248	0.0345	0.0341	0.0337	0.0572	0.0107
C3=	0.0012	0.0013	0.0013	0.0014	0.0018	0.0000
i-C4	0.0000	0.0008	0.0008	0.0008	0.0013	0.0000
n-C4	0.0014	0.0016	0.0016	0.0016	0.0021	0.0010
trans -C4=	0.0000	0.0000	0.0000	0.0000	0.0000	0.0000
1-C4=	0.0000	0.0000	0.0000	0.0000	0.0000	0.0000
iso-C4=	0.0000	0.0000	0.0000	0.0000	0.0000	0.0000
cis-C4=	0.0000	0.0000	0.0000	0.0000	0.0000	0.0000
C5	0.0000	0.0000	0.0000	0.0000	0.0000	0.0000
18.9170	0.0000	0.0000	0.0000	0.0000	0.0000	0.0000
Benzene	8.7779	8.8838	8.6050	8.3216	8.6742	8.5490
Toluene	0.0058	0.0095	0.0091	0.0089	0.0204	0.0021
Et-Benzene	0.9223	1.0528	1.0467	1.0286	1.1388	0.6555
m/p Xylene	0.0000	0.0007	0.0006	0.0006	0.0017	0.0000
o-Xylene	0.0000	0.0000	0.0000	0.0000	0.0007	0.0000
iPB	0.0270	0.0271	0.0273	0.0270	0.0254	0.0245
PB	0.0000	0.0000	0.0000	0.0000	0.0000	0.0000
Et-Toluene	0.0026	0.0035	0.0035	0.0034	0.0069	0.0010
A	0.0014	0.0007	0.0007	0.0007	0.0011	0.0000
B	0.0013	0.0011	0.0012	0.0012	0.0020	0.0000
1,3-DEB	0.0137	0.0153	0.0156	0.0155	0.0157	0.0096
1,4-DEB	0.0071	0.0078	0.0080	0.0079	0.0078	0.0054
1,2-DEB	0.0004	0.0008	0.0007	0.0007	0.0013	0.0000
TEB	0.0042	0.0070	0.0062	0.0041	0.0141	0.0000
SUM DEB	0.0212	0.0238	0.0243	0.0240	0.0248	0.0150
SUM Xyl	0.0000	0.0007	0.0006	0.0006	0.0024	0.0000
Total	100.0000	100.0000	100.0000	100.0000	100.0000	100.0000