

University of Bath



PHD

Synaptic plasticity processes underlying consolidation and reconsolidation of Pavlovian conditioning

Rigby, Peter

Award date:
2013

Awarding institution:
University of Bath

[Link to publication](#)

General rights

Copyright and moral rights for the publications made accessible in the public portal are retained by the authors and/or other copyright owners and it is a condition of accessing publications that users recognise and abide by the legal requirements associated with these rights.

- Users may download and print one copy of any publication from the public portal for the purpose of private study or research.
- You may not further distribute the material or use it for any profit-making activity or commercial gain
- You may freely distribute the URL identifying the publication in the public portal ?

Take down policy

If you believe that this document breaches copyright please contact us providing details, and we will remove access to the work immediately and investigate your claim.

Synaptic plasticity processes underlying consolidation and reconsolidation of Pavlovian conditioning

Peter Thomas Rigby

A thesis submitted for the degree of Doctor of Philosophy

University of Bath

Department of Pharmacy and Pharmacology

December 2012

COPYRIGHT

Attention is drawn to the fact that copyright of this thesis rests with the author. A copy of this thesis has been supplied on condition that anyone who consults it is understood to recognise that its copyright rests with the author and that they must not copy it or use material from it except as permitted by law or with the consent of the author.

This thesis may be made available for consultation within the University Library and may be photocopied or lent to other libraries for the purposes of consultation.

Table of Contents

List of figures	9
Acknowledgments	17
Abstract.....	18
List of Abbreviations	19
Chapter 1: Introduction	22
1.1 Introduction	23
1.2 The reward system.....	24
1.3 Animal models used to study drugs of abuse.....	28
1.4 Drug addiction as a pathology of learning and memory	32
1.5 The hippocampus.....	35
1.5.1 General anatomy of the hippocampus	35
1.5.3 Functions of the hippocampus	42
1.5.4 The functions of the hippocampus of relevance to addiction- related behaviours	48
1.6 Synaptic transmission in CA1	50
1.7 Mechanisms of synaptic plasticity in CA1.....	54
1.7.1 NMDAR-LTP	55

1.7.2	NMDAR-LTD/mGluR-LTD	69
1.8	Synaptic plasticity and memory	70
1.9	Addictive substances evoke synaptic plasticity	72
1.9.1	The ventral tegmental area	72
1.9.2	The nucleus accumbens	75
1.9.3	The medial prefrontal cortex	77
1.9.4	The amygdala	77
1.9.5	The hippocampus	78
1.10	Actions of morphine in CA1	80
1.11	Hippocampal synaptic plasticity as a possible therapeutic target for the treatment of drug addiction.....	81
1.12	Rationale for Experimental Design	83
1.13	Aims of the project.....	84
Chapter 2:	Methods	85
2.1	Introduction	86
2.2	Behavioural methods.....	86
2.2.1	Animals used	86

2.2.2	Handling/identification	86
2.2.3	Experimental protocol: conditioned place preference (biased).....	86
2.2.4	Experimental protocol: conditioned place preference (unbiased).....	88
2.2.5	Experimental protocol: non-contingent administrations.....	89
2.2.6	Drugs used.....	89
2.3	Electrophysiology methods	91
2.3.1	Brain slice preparation	91
2.3.2	Extracellular field recordings.....	91
2.3.3	Whole-cell patch clamp electrophysiology	93
2.4	Drugs.....	97
2.5	Solutions	97
Chapter 3:	Investigating the Effects of Morphine and Morphine-	
	induced Place Preference on the Functioning of	
	Hippocampal CA1 Synaptic Transmission using Field	
	Recordings.....	100
3.1	Introduction	101
3.2	Results	102
3.2.1	Stimulus-induced long-term potentiation (LTP) and long-term depression (LTD)	103

3.2.2	Morphine-induced conditioned place preference (MOR CPP)	106
3.2.3	Effects of morphine treatment and morphine CPP training on stimulus-induced LTP.....	107
3.2.4	Effects of conditioned place preference training with saline injections on stimulus-induced LTP	109
3.2.5	Investigating the mechanisms underlying increased variability of responses after morphine CPP	116
3.2.6	Investigating pre-synaptic effects of MOR and MOR CPP treatments	121
3.2.7	Investigating a possible pre-synaptic component of stimulus-induced LTP	123
3.3	Summary.....	125
Chapter 4: Examination of Post-Synaptic Changes in CA1 caused by Morphine and Morphine-induced Place Preference Using Whole-Cell Patch Clamp.....		127
4.1	Introduction	128
4.2	Results	128
4.2.1	A new model of morphine-induced conditioned place preference....	128
4.2.2	AMPA:NMDA in CA1 neurones following MOR and MOR CPP treatment.....	130
4.2.2	Investigating whether AMPA:NMDA is correlated with magnitude of expression of conditioned place preference learning	133

4.2.3	Investigating possible subsets of CA1 neurones – relationship to AMPA:NMDA following MOR CPP training	135
4.2.4	Investigating the change in EPSC amplitude after non-contingent MOR treatment	141
4.2.5	Investigating the relationship between AMPA:NMDA and holding current.....	143
4.2.6	Investigating the mechanism by which holding current and AMPA:NMDA are correlated.....	147
4.2.7	Investigating the surface expression and subunit composition of AMPA receptors following <i>in vivo</i> treatments	150
4.3	Summary.....	153
Chapter 5:	Examination of Presynaptic Changes in CA1 caused by Morphine and Morphine-induced Place Preference Using Whole-Cell Patch Clamp.....	155
5.1	Introduction	156
5.2	Results	156
5.2.1	Paired-pulse facilitation of EPSCs following MOR and MOR CPP treatments.....	156
5.2.2	Miniature excitatory post-synaptic currents following contingent and non-contingent <i>in vivo</i> morphine treatments	159
5.2.3	Properties of miniature excitatory post-synaptic currents following contingent and non-contingent <i>in vivo</i> morphine treatments.....	166

5.2.4	Miniature inhibitory post-synaptic currents following <i>in vivo</i> treatments	173
5.2.5	Properties of miniature inhibitory post-synaptic currents following <i>in vivo</i> morphine treatments	180
5.3	Summary	187
Chapter 6:	General Discussion	188
6.1	Introduction	189
6.2	Morphine-induced conditioned place preference.....	189
6.3	Effects of morphine treatment on fEPSP recordings	194
6.4	Effects of morphine-induced CPP on fEPSP Recordings	197
6.5	AMPA:NMDA is increased by morphine treatment	199
6.6	Morphine-induced CPP has complex effects on AMPA:NMDA.....	207
6.7	Glutamate release is reduced by MOR treatment	209
6.8	Glutamate release is unaffected by MOR CPP treatment	211
6.9	Summary of major findings.....	212
6.10	Interpretation of results.....	214
6.11	Suggestions for further work and conclusion.....	216
Appendix.....	219

A.1	Conditioned place preference experiments.....	220
A.1.1	Introduction.....	220
A.1.2	Dose-response curve.....	224
A.1.3	Single vs double injections.....	225
A.1.4	Further environmental changes.....	227
A.1.5	The design of a biased experiment.....	227
A.1.6	Collection of fEPSP data.....	230
A.1.7	Redesign of CPP paradigm.....	233
A.2	Optimisation of patch clamp methods.....	236
A.2.1	Isolation of the compound AMPA/NMDA current.....	236
A.2.2	Measurement of AMPA:NMDA values.....	244
	References.....	250

List of figures

Chapter 1: Introduction	22
1.1 A highly simplified diagram of some important neural connections in the mesocorticolimbic reward system.....	26
1.2 A simplified diagram of some of the major external and internal connections for the hippocampus.....	36
1.3 A diagram summarising some of the intrinsic connections in the hippocampus.....	41
1.4 Synaptic transmission at a glutamatergic synapse.....	52
Chapter 2: Methods	85
2.1 A table showing the handling and treatment performed on a cage of four mice undergoing conditioned place preference.....	90
2.2 A schematic representation of the hippocampus showing the approximate location of the recording and stimulating electrodes during fEPSP recordings.	92
2.3 A schematic representation of the theta burst protocol.....	93
2.4 Selection of time points for the measurement of AMPA:NMDA.	96
Chapter 3: Investigating the Effects of Morphine and Morphine-induced Place Preference on the Functioning of Hippocampal CA1 Synaptic Transmission using Field Recordings.	100
3.1 Stimulus-induced long-term potentiation (LTP).....	104

3.2	Stimulus-induced long-term depression (LTD).	105
3.3	Morphine-induced conditioned place preference (CPP).....	107
3.4	Effect of non-contingent morphine on stimulus-induced LTP.....	108
3.5	Effect of morphine-induced conditioned place preference training on stimulus-induced LTP	109
3.6	Effect of CPP training in the absence of morphine administration on stimulus-induced LTP.	111
3.7	Overall effects of morphine and conditioned place preference training on stimulus-induced LTP.....	112
3.8	Increased variability of stimulus-induced LTP following conditioned place preference training.....	114
3.9	Comparison of stimulus-induced LTP following MOR and MOR CPP.....	115
3.10	Comparison of stimulus-induced LTP following non-contingent saline treatment and untreated animals.....	117
3.11	Correlation plot of time-lag between end of behavioural treatment and ex vivo stimulus-induced LTP.	118
3.12	Correlation plot of conditioned place preference behaviour and ex vivo stimulus-induced LTP.	120
3.13	Paired-pulse facilitation following different <i>in vivo</i> treatments.....	122
3.14	Paired-pulse facilitation following different <i>in vivo</i> treatments after stimulus-induced LTP induction.....	123

3.15	Paired-pulse facilitation before and after stimulus-induced LTP induction following different <i>in vivo</i> treatments.	124
3.16	A cartoon to illustrate the two possible interpretations of a reduction in stimulus-induced LTP.....	126
Chapter 4: Examination of Post-Synaptic Changes in CA1 caused by Morphine and Morphine-induced Place Preference Using Whole-Cell Patch Clamp.....		
		127
4.1	Morphine-induced conditioned place preference (CPP).....	129
4.2	AMPA:NMDA at CA3-CA1 synapses after contingent and non-contingent morphine and saline treatments.....	131
4.3	Variability of AMPA:NMDA at CA3-CA1 synapses.....	133
4.4	Correlation plot of conditioned place preference behaviour and AMPA:NMDA.....	134
4.5	Stimulus intensity required to elicit 75% of max EPSC.....	135
4.6	Correlation plot of stimulation intensity and AMPA:NMDA in slices taken from mice that underwent MOR CPP treatment.	136
4.7	Whole-cell capacitance.	137
4.8	Correlation plot of whole-cell capacitance and AMPA:NMDA in slices taken from mice that underwent MOR CPP treatment.	138
4.9	Magnitude of evoked EPSC.	139
4.10	Correlation plot of 75% of max EPSC amplitude and AMPA:NMDA in slices taken from mice that underwent MOR CPP treatment.	140

4.11	Magnitude of evoked EPSC normalised to whole-cell capacitance.....	142
4.12	Holding current at -70mV across treatment groups.....	144
4.13	Correlation plot of holding current at -70mV and AMPA:NMDA in slices taken from mice that underwent MOR CPP treatment.	145
4.14	Correlation plot of holding current at -70mV and AMPA:NMDA.....	146
4.15	Correlation plot of holding current at -70mV and holding current at +40mV.....	148
4.16	Correlation plot of holding current at -70mV and whole-cell capacitance.....	149
4.17	Effects of bath-applied AMPA following contingent and non-contingent <i>in vivo</i> morphine treatments.....	151
4.18	Effect of Joro Spider Toxin (JSTx) on evoked EPSCs following <i>in vivo</i> treatments.....	153
Chapter 5:	Examination of Presynaptic Changes in CA1 caused by Morphine and Morphine-induced Place Preference Using Whole-Cell Patch Clamp.....	155
5.1	Paired pulse ratio at Schaffer-Collateral-CA1 synapses after contingent and non-contingent morphine and saline treatments <i>in vivo</i>	157
5.2	Correlation plot of Paired Pulse Ratio and AMPA:NMDA ratios.....	158
5.3	Miniature EPSC frequency at Schaffer-Collateral-CA1 synapses after contingent and non-contingent morphine and saline treatments.....	160

5.4	Miniature EPSC frequency at Schaffer-Collateral-CA1 synapses after SAL or MOR treatments.	161
5.5	Miniature EPSC frequency at Schaffer-Collateral-CA1 synapses after conditioned place preference.	162
5.6	Miniature EPSC amplitude at Schaffer-Collateral-CA1 synapses after different <i>in vivo</i> treatments.	163
5.7	Miniature EPSC amplitude at Schaffer-Collateral-CA1 synapses after MOR or SAL treatments.	164
5.8	Miniature EPSC amplitude at Schaffer-Collateral-CA1 synapses after conditioned place preference.	165
5.9	Miniature EPSC rise times at Schaffer-Collateral-CA1 synapses after <i>in vivo</i> treatments.	167
5.10	Miniature EPSC rise times at Schaffer-Collateral-CA1 synapses after SAL or MOR treatments.	168
5.11	Miniature EPSC rise times at Schaffer-Collateral-CA1 synapses after conditioned place preference.	169
5.12	Miniature EPSC decay times at Schaffer-Collateral-CA1 synapses after <i>in vivo</i> treatments.	170
5.13	Miniature EPSC decay times at Schaffer-Collateral-CA1 synapses after SAL or MOR treatments.	171
5.14	Miniature EPSC decay times at Schaffer-Collateral-CA1 synapses after conditioned place preference.	172

5.15	Miniature IPSC frequency at Schaffer-Collateral-CA1 synapses after <i>in vivo</i> treatments.	174
5.16	Miniature IPSC frequency at Schaffer-Collateral-CA1 synapses after MOR or SAL treatments.	175
5.17	Miniature IPSC frequency at Schaffer-Collateral-CA1 synapses after conditioned place preference.	176
5.18	Miniature IPSC amplitude at Schaffer-Collateral-CA1 synapses after <i>in vivo</i> treatments.	177
5.19	Miniature IPSC amplitude at Schaffer-Collateral-CA1 synapses after SAL or MOR treatments.	178
5.20	Miniature IPSC amplitude at Schaffer-Collateral-CA1 synapses after conditioned place preference.	179
5.21	Miniature IPSC rise times at Schaffer-Collateral-CA1 synapses after contingent and non-contingent morphine and saline treatments.	181
5.22	Miniature IPSC rise times at Schaffer-Collateral-CA1 synapses after SAL or MOR treatments.	182
5.23	Miniature IPSC rise times at Schaffer-Collateral-CA1 synapses after conditioned place preference.	183
5.24	Miniature IPSC decay times at Schaffer-Collateral-CA1 synapses after <i>in vivo</i> treatments.	184
5.25	Miniature IPSC decay times at Schaffer-Collateral-CA1 synapses after SAL or MOR treatment.	185

5.26	Miniature IPSC decay times at Schaffer-Collateral-CA1 synapses after conditioned place preference.	186
Chapter 6: General Discussion		188
6.1	A table summarising major findings.....	213
Appendix.....		219
A.1	The effects of different environmental contexts on subject preference...	223
A.2	A graph to show the effect of morphine dose on the detection of place preference.	224
A.3	The effects of different injection paradigms on the expression of place preference.	226
A.4	Results of a pre-test during further environmental optimisation.....	227
A.5	An example of a biased morphine CPP experiment.....	228
A.6	Effects of red lighting on the behaviour of saline control CPP group.....	229
A.7	Collated saline- and morphine-induced CPP data from the period over which fEPSP experiments were being performed.	231
A.8	Final environmental optimisation experiment comparing plain and stripy compartments.....	234
A.9	Saline- and morphine-induced CPP during the period that the patch clamp data was being collected.....	235
A.10	The recorded EPSC at -70mV in the presence of 100µM picrotoxin is mediated largely by glutamate.	237

A.11	Examples of variable effects of 100 μ M picrotoxin.	238
A.12	Effects of 100 μ M picrotoxin on paired pulse ratios in slices taken from naive mice.	239
A.13	500 μ M DNDS fails to completely inhibit the picrotoxin sensitive current.	241
A.14	The inclusion of fluoride ions into the pipette solution is effective in inhibiting IPSCs observed at 0mV.	243
A.15	50 μ M D-APV has variable effects on EPSCs in CA1 pyramidal neurones.	245
A.16	MK-801 induction protocol does not result in LTD.	246
A.17	Picrotoxin reaches maximum effect in approximately 3 minutes.	248
A.18	A graph to show the current output of the stimulus isolation unit.	249

Acknowledgments

This work was performed under the supervision of Dr Chris Bailey with financial support from the BBSRC.

Special thanks go to Laura McNair for helping perform the field recordings presented in this thesis and to Dr Chris Bailey for the excellent support and supervision throughout the project. This work would not have been possible without them. All data presented here were generated by myself with the exception of some field recording experiments performed jointly with Laura McNair.

I would also like to thank Janet Lowe for technical support, and all of the staff in 4 south annex for taking care of the animals used in this study.

For support in this work and all other aspects of my life I would also like to thank Kelli Roberts, and my parents Mary and Steve.

Abstract

In the field of drug addiction, relapse back to drug seeking and taking is the major unmet clinical need. The rate of relapse back to drug-taking is ~70-80% within a year of drug abstinence. Gaining a better understanding of the prolonged neuronal changes that have taken place during drug addiction may lead to the design of better anti-relapse therapies. It is now widely believed that one component of drug addiction is by aberrant learning and memory processes. To study this, we investigated synaptic changes caused by the development of drug-seeking behaviour in C57BL/6J mice. Mice were treated either with non-contingent morphine or trained to exhibit drug-seeking behaviour following morphine-induced conditioned place preference (CPP) training, hippocampal slices were taken from these animals and synaptic changes examined at the CA3-CA1 synapse using electrophysiological methods. Mice that underwent morphine CPP were demonstrated to exhibit a significant preference for the morphine paired compartment before *ex vivo* electrophysiological analysis. Using field recordings, both non-contingent morphine and morphine CPP treatments resulted in a reduced ability to undergo stimulus-induced LTP compared to their respective controls. Whole cell patch clamp was then utilised to further investigate these effects. Non-contingent morphine treatment resulted in both pre- and post-synaptic changes with an increased AMPA:NMDA receptor ratio, concurrent increases in cell size, and reductions in the release probability of both glutamate and GABA. Morphine CPP treatment resulted in a more variable increase in AMPA:NMDA receptor ratio (presumably by the same mechanism but in a more specific group of neurones) and GABA release probability was also decreased. There were no detected increases in cell size however, or any detected changes in glutamate release probability. These findings therefore reveal a set of synaptic adaptations in the hippocampus unique to morphine-induced behavioural change, and may provide targets for future intervention in drug addiction.

List of Abbreviations

5-HT	5-Hydroxytryptamine
ACPD	1-Amino-1,3-dicarboxycyclopentane
ACSF	Artificial cerebrospinal fluid
AMPA(R)	2-amino-3-(3-hydroxy-5-methyl-isoxazol-4-yl)propanoic acid (receptor)
ANOVA	Analysis of variance
APV	(2 <i>R</i>)-amino-5-phosphonovaleric acid
ATP	Adenosine triphosphate
BLA	Basolateral amygdala
CA1-3	Cornu ammonis regions 1-3
CaMK II - IV	Ca ²⁺ /calmodulin-dependent protein kinase II - IV
CeA	Central nucleus of the amygdala
CNQX	6-cyano-7-nitroquinoxaline-2,3-dione
CPP	Conditioned place preference
CR	Conditioned response
CREB	cAMP response element-binding protein
CRF	corticotrophin-releasing factor
CS	Conditioned stimulus
DG	Dentate gyrus
DHPG	3,5-Dihydroxyphenylglycine
DNDS	4,4'-Dinitro-stilbene-2,2'-disulfonic acid
EE	Environmental enrichment
EEG	Electroencephalogram
EGTA	Ethylene glycol tetraacetic acid
E-LTP	Early-long term potentiation
EPSC	Excitatory postsynaptic current

fEPSP	Field excitatory postsynaptic potential
F-test	Fisher-test
GABA	Gamma-aminobutyric acid
GIRK	G-protein coupled inwardly-rectifying potassium channel
GPCR	G-protein coupled receptor
G-protein	Guanosine nucleotide-binding protein
GTP	Guanosine triphosphate
HEPES	hydroxyethyl piperazineethanesulfonic acid
HM	Henry Gustav Molaison
IP3K	Inositol 1,4,5-trisphosphate 3-kinase
IPSC	Inhibitory postsynaptic current
JSTx	Joro spider toxin
KS-test	Kolmogorov–Smirnov test
LFS	Low frequency stimulation
LIA	Large irregular activity
L-LTP	Late-long term potentiation
LTD	Long term depression
LTP	Long term potentiation
MAPK	Mitogen-activated protein kinase
MCPG	α -Methyl-4-carboxyphenylglycine
mEPSC	Miniature excitatory postsynaptic current
mGluR	Metabotropic glutamate receptor
mIPSC	Miniature inhibitory postsynaptic current
MK-801	Dizocilpine
mPFC	Medial prefrontal cortex
mRNA	Messenger ribonucleic acid
MSN	Medium spiny neurone
NAc	Nucleus accumbens

NMDA(R)	N-methyl-D-aspartate (receptor)
PET	Positron emission topography
PFC	Prefrontal cortex
PKA	cAMP dependent protein kinase
PKC	Protein kinase C
PLC	Phosolipase C
P _o	Open probability
PPF	Paired pulse facilitation
P _r	Release probability
PSD	Postsynaptic density
QX314	<i>N</i> -(2,6-Dimethylphenylcarbamoylmethyl) triethylammonium
SEM	Standard error of the mean
SIA	Small irregular activity
SNAP-25	Synaptosomal-associated protein 25
SNARE	Soluble NSF attachment <i>protein</i> receptor
TARP	Transmembrane AMPA regulatory protein
US	Unconditioned Stimulus
VGCC	Voltage-gated calium channel
VTA	Ventral tegmental area
ZIP	z-inhibitory peptide

Chapter 1: Introduction

1.1 Introduction

Drug addiction represents a major socioeconomic burden on society not only in the UK but worldwide. It has effects not only on the health of individuals, but also on social cohesion and crime. In the year 2000, WHO estimated that 12% of deaths annually were due to non-medicinal drug use (www.who.int). In the UK the estimated socioeconomic cost of drug addiction is £15.4 billion per annum (Gordon *et al.* 2006). There is currently an unmet need for the treatment of drug addiction with 70% of 'recovered' addicts relapsing within one year (Nutt and Lingford-Hughes, 2004). The dogma of modern addiction theory is the idea that addictive substances somehow usurp the brain's natural control of behaviour, and so induce a pathological behavioural state. In order to identify rational targets for pharmacological intervention in drug addiction it is first necessary to elucidate the mechanism that leads to the addictive state.

In this work, addiction is defined as *a pathological change in behaviour, centred around the search for and consumption of a particular substance*. Examples of this pathological change in behaviour range from the continued consumption of a drug despite detrimental effects on health or well being, to acts such as burglary in order to obtain money to buy more of the drug.

This study focuses on one particular brain structure within the mesocorticolimbic system (often called the reward system) known as the hippocampus. Specifically, this study investigates the effects of behavioural adaptations induced by morphine on hippocampal synaptic transmission.

In this introduction the idea of drug addiction as a pathological alteration in the brain's natural learning and memory processes will be presented. First by introducing key brain areas thought to be involved in reward, giving a hypothesis of how reward can drive behaviour. Then the concept of synaptic plasticity as the cellular correlate of learning and memory will be introduced and the effects of addictive substances discussed. Finally this introduction will concentrate on the hippocampus, giving an up to date overview of present ideas surrounding the role of this much studied brain structure in addiction.

1.2 *The reward system*

Modern biology states that the behaviour of all living organisms is directed toward survival of their genetic code. Many mobile organisms are capable of responding behaviourally to environmental changes in a manner that is dependent on previous experience. Fundamental to this behavioural plasticity is the brain and its ability to integrate large amounts of environmental information with information stored from previous experience. In order to survive and reproduce these organisms depend on their ability to decide when to perform certain 'goal directed behaviours' such as chasing food, seeking water or attempting to mate. By making rational decisions based on previous similar experiences they are able to expend the minimum amount of required energy to obtain nutrition and sex, and so gain a survival advantage. Similar to natural rewards, animals will rapidly learn predictive cues and complex behavioural responses in order to obtain addictive substances. Anecdotally, addictive substances share many of the same subjective sensations of natural rewards such as 'wanting' and 'liking'. This suggests the brain systems usurped by addictive substances could include some of those involved in the seeking of survival relevant goals (Kelley and Berridge, 2002).

This decision to expend valuable energy in the pursuit of a survival orientated goal is dependent on many factors, such as - the perceived value of the goal, the likely energetic cost of the planned behaviour, any current internal state such as thirst or hunger, and the predicted probability of a successful outcome. It seems likely that alterations in any of these calculations could lead to inappropriate (or even pathological) behaviour (Robinson and Berridge, 2008; Beeler, 2012). The selection of behaviours relevant to survival is likely to be attributable to entire neural networks if not the whole brain rather than any one particular structure, and is far from understood. One system that is thought by many to be central to the detection of reward and/or the selection of behaviour is known as the mesocorticolimbic system (Figure 1.1).

The mesocorticolimbic reward system comprises of dopaminergic neurones arising in the ventral tegmental area (VTA) and projecting to various cortical and limbic regions including the nucleus accumbens (NAc), medial prefrontal cortex (mPFC), amygdala and hippocampus. Each of these regions receives dopaminergic input

from the VTA but are also functionally connected with each other by direct and indirect glutamatergic and GABAergic connections. The early observations that animals would self administer electrical stimulation into the VTA (Olds and Milner, 1954) combined with experiments in human subjects (Heath, 1964) led to the idea that activity in this region could mediate some aspect of pleasure. Direct activation of this brain region causes such a strong behavioural response in laboratory animals that they will impose self starvation if given the choice between food and water or electrical stimulation (Routtenberg and Lindy, 1965). This feature along with a lack of satiation (>6,000 lever presses per hour; Bozarth, 1994) are a cardinal feature of direct stimulation of these mid brain dopamine neurones. All addictive substances are capable of causing the release of dopamine from these midbrain neurones, despite their varying mechanisms of action (Di Chiara and Imperato, 1988).

The exact information encoded by these VTA dopamine neurones has been the subject of intense debate for over half a century now. While ever more sophisticated imaging, behavioural, and electrophysiological experiments are being performed, these arguments can still essentially be split in to two classes - those that argue VTA activation mediates the desire to act in order to acquire a reward (motivational theories), and those that argue VTA activation mediates consolidation of memories (learning theories).

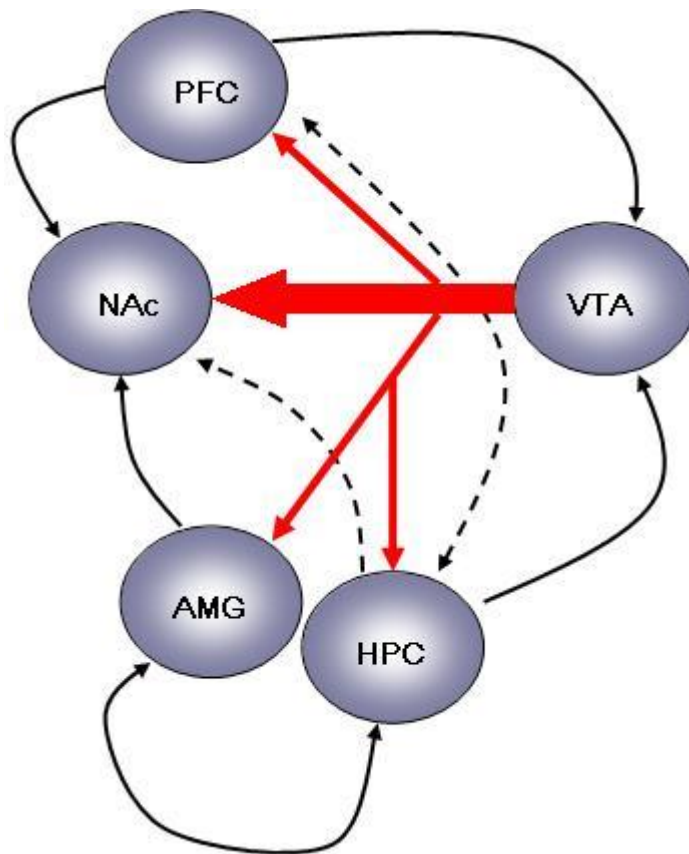

Figure 1.1 A highly simplified diagram of some important neural connections in the mesocorticolimbic reward system.

The dopaminergic projections from the VTA are drawn in red, whilst the black arrows represent glutamatergic projections (some lines are dashed for clarity). This is a highly simplified diagram and other direct and indirect connections exist between these brain regions. The general function of this network is thought to be the initiation of goal-directed behaviour. The nucleus accumbens can be thought of as the final output structure of this system where signals coming from the prefrontal cortex (PFC), the amygdala (AMG) and the hippocampus (HPC) are integrated under modulation by the ventral tegmental area (VTA). The nucleus accumbens projects to a variety of brain regions associated with motor function in the basal forebrain and hypothalamus.

One popular idea concerning the precise role played by the firing of midbrain dopamine neurones is that it detects a reward prediction error. In monkeys VTA dopamine neurones fire in response to the receipt of an unexpected reward (Mirenowicz and Schultz, 1994; Schultz *et al.* 1993) consistent with their role encoding reward. The activation of these neurones is even proportional to the size of the reward (Tobler *et al.* 2005). This supports the idea that VTA dopamine neurones are heavily implicated (in some way) in reinforcement/reward related learning. However the role of dopamine release is likely to be more complex than simply encoding a reward or its size. If the reward is correctly predicted by a cue VTA dopamine neurones do not fire, and if the reward occurs earlier or later than expected then again these neurones increase in their firing rate (Tobler *et al.* 2005). These properties of VTA dopamine neurones are consistent with the properties of reward prediction error encoding as predicted by the machine learning hypothesis (Schultz, 2002). This reward prediction error model of dopamine function is probably the most influential hypothesis presently, but is not without its problems. For example the pause in tonic activity predicted in the absence of an expected reward is not consistently shown (Bayer and Glimcher, 2005; Satoh *et al.* 2003) and some studies find dopamine neurones that continue to increase their firing rate upon receipt of a fully expected reward (Pan *et al.* 2005). The reward prediction error model also fails to explain a phenomenon known as behavioral priming. Behavioral priming describes the effect giving a free reward has in intensifying a behavioral response to a reward related cue (Gallistel *et al.* 1974). This priming effect has been demonstrated for both drug (Phillips *et al.* 2002) and natural rewards (Roitman *et al.* 2004).

The nucleus accumbens forms part of the striatum whose function (in a very broad sense) is thought to be the conversion of thought into action. For this reason the output from the nucleus accumbens is thought to be the final output from a system that drives goal directed behaviours. As stated before the selection of behaviours depends on many factors other than those directly related to reward, such as the context the animal is in, or internal emotional states. So while the predicted value of the reward or the motivation to get a reward may depend on signals from the VTA; various other brain regions provide important information such as previously learnt reward-cue associations (thought to be mediated by the amygdala), the identification of drug predictive contexts (thought to be mediated by the

hippocampus) or other higher cognitive information related to the situation such as conscious desires, often called executive control (possibly mediated by the prefrontal cortex). Each of these inputs to the nucleus accumbens is required for the normal physiological function of the reward system and therefore each is required for the appropriate selection of behaviours. It is easy to imagine a situation where dysfunction of any of these brain regions could lead to the pathological selection of behaviours.

All addictive substances (despite their varied mechanisms of action) can cause the release of dopamine in the nucleus accumbens from VTA neurones (Wise and Bozarth 1987, Koob and Bloom 1988, Di Chiara 1998, Wise 1998). This convergence of the actions of addictive substances led to the idea that a generalised theory of addiction could be developed. In order to further develop this common theory of addiction, researchers have attempted to model certain aspects of human behaviour in laboratory animals.

1.3 Animal models used to study drugs of abuse

In the design of any animal model there will always be two contradictory requirements; the requirement to closely model the human condition and thereby maximise validity, and the requirement to simplify the model to increase reproducibility and make drawing conclusions easier. This problem is particularly acute when attempting to model a complex behavioural disorder such as drug addiction, although through careful interpretation of the models appropriate conclusions can be drawn.

Designing models with high face validity, that is, to model the human condition as closely as possible; is always going to be extremely difficult given the vast difference in normal behaviour exhibited between humans and rodents. A different approach to designing models is to aim for high construct validity; that is, to model as closely as possible one specific construct of addictive behaviour - such as impulse control, incentive sensitisation, or habit formation. This construct validity method has gained popularity in studies of drug addiction as it allows for the design of reasonably valid models with simple, reproducible outcomes.

The most simple aspect of drug abuse to model is the reinforcement of behaviour by addictive substances. Reinforcement is a concept developed by Skinner (1938) and describes the effect that a salient stimulus can have when given in a manner that is contingent on a specific behaviour. Reinforcing stimuli can either increase the probability of a behaviour being repeated (positive reinforcement) or decrease the probability of a behaviour being repeated (negative reinforcement). The term positive reinforcement is often used interchangeably with reward, however this can be unhelpful as it implies some kind of positive subjective state. It is unclear if animals other than humans experience such positive subjective states. Even in humans positive reinforcement occurs in the absence of any clear positive subjective state (an example would be the positive reinforcing properties of nicotine). Throughout this work the term 'positive reinforcement' is shortened to 'reinforcement', as is common in the literature. Addictive drugs can act through both primary and secondary reinforcement mechanisms. Primary reinforcement is seen in both humans and animals in that they will self administer drug and the act of drug taking is reinforced. Secondary reinforcement is subserved by the learning of drug-cue associations through Pavlovian conditioning processes. Pavlovian conditioning is where the presentation of a salient stimulus, called the unconditioned stimulus (US, in this case an addictive drug), is repeatedly paired to the presentation of a previously neutral stimulus (CS, such as a light or tone, for example). The result of this process is that the CS is learnt to predict the availability of the US and elicits a response - the conditioned response. Eventually the CS can take on motivational properties of its own, helping to prolong behaviour even in the absence of the US (Everitt and Robbins, 2005).

Primary reinforcement can be modelled using the self administration paradigm. Self-administration models have perhaps the most immediately obvious validity to the human condition. These models are classified as either operant or non-operant, depending on whether the animal has to perform a specific action in order to receive a drug. The non-operant model is really only commonly used to study alcohol use, mostly due to the fact that rodents hardly consume alcohol by any other route of administration other than orally (Sanchis-Segura and Spanagel, 2006). The operant model commonly makes use of a so called 'Skinner-box' where the animal is placed and one or more *manipulandi* are present. These *manipulandi* (commonly levers, but can be places to poke with a nose or disks to peck) are

activated in order to gain delivery of the drug, this is often via intravenous or intracranial cannulation and therefore requires the disadvantage of having to perform surgery on the animal prior to training. Once set-up however this procedure has the advantage of near complete automation, increasing reproducibility. The number of actions required to gain the drug delivery can be altered, known as the schedule of reinforcement and so allows investigation of the motivational properties of the drug. However, the use of interventions to prevent 'drug seeking behaviour' (lever presses) must be treated with caution as reductions in motor function can cause complications in interpreting these kind of results. Another confounding factor in self administration protocols is due to the instrumental learning required to perform the task. It is often not clear what adaptations have occurred in response to the learning of the task rather than the drug-task associations (Gardner, 2000). In the case of the present study there were a number of factors that indicated against the use of this model. The requirement for young animals for brain slice electrophysiology meant that surgery and recovery before training would have been performed on extremely young animals. Also self-administration requires large numbers of trials and drug doses, and therefore the effects of tolerance and withdrawal are likely to complicate interpretation.

The conditioned place preference (CPP) model is extensively used to study the reinforcing effects of drugs of abuse. This model is widely presumed to depend on a type of contextual Pavlovian conditioning (second order reinforcement) whereby non-contingent administration of the drug is repeatedly paired with one particular distinct environment. Briefly, this involves exposing the animal to one distinct environment (context) immediately after administration of the drug under study. Then after sufficient time has elapsed to allow for the drug's effects to dissipate, the animal is exposed to the second context immediately after administration of the drug vehicle. These two contexts can be distinguishable by visual, tactile or olfactory cues (Tzschentke, 2007). Preference for a particular environment is then tested for during a drug free phase where the animal is allowed access to both compartments, and the time spent in each compartment is measured. Conditioned place preference is defined as an increase in the amount of time spent in the drug-paired context, or the development of a preference where previously there was none. CPP can be induced by nearly all substances with abuse potential in

humans. Notable exceptions include pentobarbital and phencyclidine, although the failure of studies using these drugs to induce CPP probably represents a failure to find the correct conditions (Bardo and Bevins, 2000). The CPP model is often referred to as a model of Pavlovian conditioning and the temporal contiguity required for both Pavlovian conditioning and CPP supports this idea. For example cocaine induced CPP occurs when a rat is given cocaine immediately or 5 minutes before being placed in the specific context, whereas a conditioned place aversion is induced if cocaine is given 15 minutes before being placed in to the context (Ettenberg *et al.* 1999).

CPP has the advantages that it is relatively inexpensive, requires no surgery, is measured when the animal is free of any acute effects of the drug, is sensitive to low drug doses and relatively few training sessions are required compared to other models. The interpretation of the results however is more complex than with some other models. For example, the demonstration of CPP is variously reported as an increase in time spent in the drug-paired compartment after training compared to before; a significantly greater amount of time spent in the drug-paired compartment compared to the vehicle-paired compartment on the test day; and an increased preference for a drug-paired compartment compared to double vehicle controls. To date few studies seem to have addressed this question surrounding the handling and analysis of such data. There is also a more general problem in determining what aspect of drug seeking behaviour in humans CPP actually represents (Bardo and Bevins, 2000). Of interest to this study however was not particularly what CPP was a measure of, but a demonstration of the formation of drug-environment associations. In the case of CPP, these associations must be learnt for CPP to be expressed. A further advantage of CPP is that it can be demonstrated in animals that have received relatively small amounts of the drug. This is a particularly important factor (in the context of this study) as when using a drug that induces tolerance and physical dependence very quickly (such as morphine), the effects of learning could easily be confounded by the effects of tolerance and withdrawal.

Another commonly used behavioural model in the study of drug addiction is behavioural sensitization. The major advantage of this model appears to be its ease of use - upon repeated intermittent non-contingent administration of a drug

the motor-stimulant effect of the drug increases. As with CPP there is some debate as to what aspect of addiction it actually models (Steketee and Kalivas, 2011). Similar processes in humans have proved hard to observe. Although its longevity and its ability to augment subsequent self-administration has led to the suggestion that the mechanisms involved may at least partially overlap. While behavioural sensitization can be context-dependent (and therefore require associative learning processes) it requires the animal to be presented with drug during the test session. This complicates subsequent immediate electrophysiological analysis when using drugs such as morphine due to short term withdrawal effects.

1.4 Drug addiction as a pathology of learning and memory

The observation that both drug-taking and relapse to drug seeking are often controlled by environmental cues hints at the importance of associative learning processes in addiction. The receipt of a natural reinforcer as a consequence of behaviour results in the release of dopamine in VTA target sites (Schultz, 1997) increasing the animals ability to learn through either enhancing memory directly or increasing the motivation to learn (Taylor and Horger, 1999). The receipt of addictive drug reinforcement as a consequence of behaviour results in a dopaminergic signal that is both greater in magnitude and duration than that of a natural reward (Einhorn *et al.* 1998) and therefore could be expected to greatly increase the learning of drug predictive cues in the environment. Over time the chronic over-activation of the dopaminergic system can lead to lasting changes in the way an organism responds to reward associated cues, as well as adaptations in natural learning and memory processes. While this idea had been suspected for some time, the first really strong evidence that addictive substances usurp natural learning processes came in 1999, when Taylor and Horger (1999) demonstrated that chronic cocaine exposure could potentiate learning about a non-drug predictive cue. This effect has since been demonstrated for other psychostimulants, and also using different learning paradigms. These studies demonstrated that chronic exposure to drugs of abuse could enhance learning of subsequent reward predictive cues.

Addictive drugs can enhance other forms of learning as well as discrete cue-reward associations. Prior exposure to environments associated with either morphine or cocaine can enhance subsequent performance in a spatial learning task (the Morris water maze). This effect was not seen if the environment was associated with either a natural reward (sucrose) or stress (Zhai *et al.* 2008). Chronic exposure to cocaine can also enhance performance in a more difficult version of the Morris water maze (Del Olmo *et al.* 2006). These kind of spatial tasks are well documented to require hippocampal processing, and so these results suggest the possibility that hippocampal function may be enhanced. There is also a wealth of evidence suggesting that addictive substances can enhance the learning of new habits. Habit formation in drug seeking and taking behaviours are particularly damaging as habits are relatively insensitive to goal devaluation. This means that even when the outcome of a habit no longer results in a reward (or even results in a punishment) the animal may continue to respond, whereas goal directed behaviours rapidly change dependent on outcomes (for a review on the subject see Everitt and Robbins, 2005). The switching of learnt behaviours is thought to be mediated by the prefrontal cortex, and therefore perhaps this is one region where addictive substances may inhibit learning.

The above observations suggest that addictive substances may fundamentally alter learning and memory processes, by enhancing associative learning processes, speeding up habit formation and/or decreasing executive control. Over the many years that a person may take a drug, chronic over-activation of these learning and memory mechanisms, combined with habit formation may help induce the compulsive drug seeking behaviour often seen in long term addicts. While over learning and habit formation may help explain compulsive drug use, it provides little explanation of perhaps the largest problem with the treatment of drug addiction - relapse. It is possible that during the often long periods (perhaps 10 years or more) of drug consumption that occur before an addict attempts to abstain from their drug, many features of their environment will become associated with drug use. Upon attempting to abstain from the drug an addict may experience powerful cravings brought on through 'over learnt' environmental cues predicting drug availability.

Discrete drug-cue associations (CSs) that signal the availability of a drug (US) can exert a powerful hold over both human or rodent behaviour during abstinence or extinction respectively. Examples of this such as the sight of drug paraphernalia (in humans) effectively induce cravings. In rodent models the presentation of a tone previously paired with a drug is an effective method of reinstating drug-seeking behaviour. This so-called 'cue-induced reinstatement' appears to be dependent upon the amygdala in rodents (Meil and See, 1997). The presentation of discrete drug cues to detoxified humans can induce craving and increase the blood flow in the amygdala (amongst other limbic regions) measured by PET (Childress *et al.* 1999). In rodents the repeated presentation of the CS in the absence of the US can reduce the conditioned response to the CS over time. This process is known as extinction. Attempts to extinguish drug seeking in humans based on this idea ('exposure therapy') have largely been unsuccessful however (Marissen *et al.* 2007). One possible reason for the failure of Marissen *et al.* (2007) to prevent relapse (relapse rates actually increased) could be due to the specific context in which the cues were presented. Crombag and Shaham (2002) used a model of cue-induced relapse utilising two separate contexts, A and B. Rats first were trained to self-administer cocaine in context A. Each reinforcement was paired with the turning on of a light for 40 seconds. Drug seeking behaviour was then extinguished in context B although the light cue was still presented after a lever press. When reintroduced into context A, reinstatement of drug seeking behaviour could be induced by the contingent presentation of the light cue (lever press resulted in light but no drug, as in context B). The authors concluded that in this instance the context must function as an occasion setter. This suggests that contexts may control the ability of drug-paired cues to control behaviour. This result implies that exposure therapy would be only effective in the context that it was given. While this is not a problem in laboratory animals it represents perhaps an insurmountable challenge in humans. Therefore perhaps context-drug associations would be a better target for intervention. Again the success of exposure therapy here would likely be limited by the practical problem of recreating realistic contexts. A better understanding of the process of drug-context learning could provide better, more rational targets for intervention, pharmacological or otherwise.

The hippocampus is a brain structure heavily implicated in the formation of drug-environment associations in animal models, and also context-dependent relapse (Vorel *et al.* 2001). Therefore adaptations in the hippocampus during drug use may lead to the 'over-learning' of these drug-environment associations, memories that in humans could possibly induce relapse many years after drug taking ceased. Before the role of the hippocampus in addiction can be fully explored, it is necessary to consider its normal physiological functioning.

1.5 The hippocampus

The hippocampus is part of the hippocampal formation, a group of brain areas located in the medial temporal lobe. The famous case of patient HM who had his medial temporal lobe removed surgically for the relief of his epilepsy, marked the start of a new era in the study of memory. Since HM, the hippocampal formation has become possibly the most widely studied area in the mammalian brain. In this section, the normal physiological functioning of the hippocampus is discussed. The section begins with the general topography of the hippocampus, and then goes on to discuss how patterns of neuronal activity in the hippocampus can be correlated with certain behaviours. In the final part of this section some attempt is made to define a function for the hippocampus.

1.5.1 General anatomy of the hippocampus

A striking feature of the mouse hippocampal formation topography is the unidirectional flow of information from the dentate gyrus to CA3 (see Figure 1.2). As can be seen from this simplified Figure the superficial layers of the entorhinal cortex can be thought of as the beginning of the hippocampal formation. Information flows from the entorhinal cortex into the dentate gyrus, hippocampus proper (consisting of the major regions CA3 to CA1) and the subiculum before re-entering deeper layers of entorhinal cortex. This is of course a highly simplified view and many other unidirectional and reciprocal connections exist between various parts of the hippocampal formation and the wider brain.

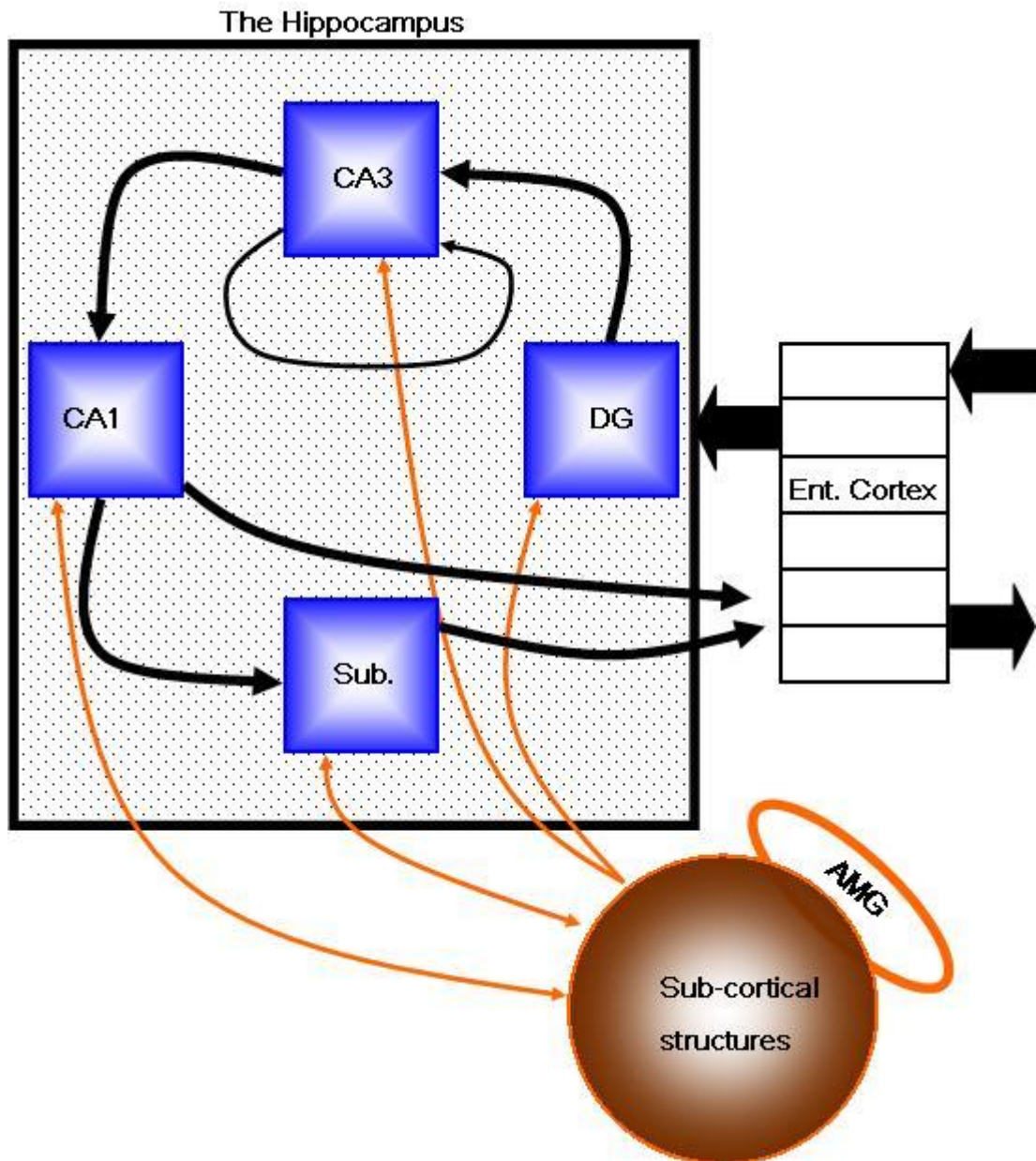

Figure 1.2 A simplified diagram of some of the major external and internal connections for the hippocampus.

A wide variety of cortical information arrives at the hippocampus via the superficial layers of the entorhinal cortex (Ent. Cortex). This information then enters the largely unidirectional hippocampal processing loop where it is further processed and integrated with information from the amygdala (AMG). This process is modulated by a wide variety of subcortical structures. An unusual feature of this brain region is the unidirectional flow of information from the entorhinal cortex, through CA3, CA1, and the subiculum (Sub.).

The entorhinal cortex is a multi-laminate structure that receives a wide variety of sensory input from areas throughout the cortex as well as various other sub-cortical inputs, most notably from the amygdala. One interesting feature of the amygdala connection to the entorhinal cortex is that it appears to only be present in the medial portion of the entorhinal cortex. The cells of the superficial layers II and III provide the main input into the hippocampal processing loop, with layer II neurones projecting to the dentate gyrus and CA3 and the layer III neurones projecting to the CA1 and subiculum. The deeper layers V and VI receive their major input from CA1 and the subiculum (the other end of the hippocampal processing loop) and convey this signal to the higher multi-modal and association areas of the cortex. Therefore the entorhinal cortex can be thought of as a conduit for the information entering and leaving the hippocampal processing loop from the wider neocortex (Amaral and Lavenex, 2007).

The dentate gyrus receives its major cortical input from layer II entorhinal cortex neurones via the perforant pathway. The perforant path terminates in the superficial molecular layer of the dentate gyrus (Hjorth-Simonsen and Jeune, 1972) where it forms synapses with dendrites of the granule cells of the dentate gyrus. The perforant path is often further divided into medial and lateral divisions based on the origin and target of the constituent neurones. The lateral perforant path neurones originate in the lateral entorhinal area and terminate in the outer third of the molecular layer, whereas the medial perforant path originates in the medial entorhinal area and terminates in the middle third of the molecular layer (van Groen *et al.* 2003). While the dentate gyrus receives relatively few sub-cortical inputs, a major input is the poorly understood innervation from the septal nuclei. This is a mixture of cholinergic and GABAergic innervation. The septal nuclei are a group of structures poorly understood (perhaps mediating attention or arousal) but known to support self-stimulation as demonstrated by Olds and Milner (1959) in their classic experiment. The dentate gyrus also receives input from various other sub-cortical structures including; a poorly defined projection from the hypothalamus, a noradrenergic projection from the locus coeruleus (Loughlin *et al.* 1986) a dopaminergic projection from the ventral tegmental area and a serotonergic projection from the dorsal raphe nucleus (Conrad *et al.* 1974). All of these sub-cortical inputs are undoubtedly important in the physiological functioning of the hippocampal processing loop. They are however likely to play more

modulatory roles in controlling how the hippocampal formation processes the information provided by the amygdala and cortex via the entorhinal cortex. Unusually for the brain, the dentate gyrus does not appear to project to any brain structure other than the CA3 area of the hippocampus. The collection of axons that originate at the granule cells of the dentate gyrus and project to CA3 are known as the mossy fibres.

The principal cells CA3 of the hippocampus proper are the only hippocampal structure to receive input from the dentate gyrus. The proximal portions of the CA3 (those closest to the dentate gyrus) have short apical dendrites and are more strongly under the influence of the granule cells (of the dentate gyrus) than the distal portions with larger apical dendrites that reach into the stratum lacunosum-moleculare (where the perforant path from the entorhinal cortex is situated) and receive direct input from layer II of the entorhinal cortex (Ishizuka *et al.* 1995, van Groen *et al.* 2002). The distal principal cells of CA3 therefore may receive the same signals transmitted to the dentate gyrus by the layer II cells of the entorhinal cortex, this parallel and serial connectivity is a feature of the hippocampal processing loop. The ventral portions of CA3 also appear to receive a significant input from the basolateral amygdala (Pikkarainen *et al.* 1999; Pitkanen *et al.* 2000) through synapses found in both the stratum radiatum and stratum oriens. The largest sub-cortical input to the CA3 (and CA1) comes from the septal nuclei (Nyakas *et al.* 1987; Gaykema *et al.* 1991) innervating both the stratum oriens as well as the stratum radiatum, these connections are reciprocal (as they also are in CA1). The CA3/CA2 region also receives a variety of modulatory influence from brain stem structures such as the locus coeruleus and dorsal raphe nucleus. One of the major differences between CA3/CA2 and CA1 is the extensive self association that occurs within CA3/CA2. In fact any one CA3 neurone may be monosynaptically connected to almost any other neurone contained in the ipsilateral CA3-CA1 (Li *et al.* 1994). The CA3 to CA1 projection (the Schaffer-collaterals) contact the apical dendrites in the stratum radiatum and the basal dendrites of the stratum oriens (Li *et al.* 1994).

The CA1 sub-region of the hippocampus gets the majority of its excitatory input from the CA3 projection as already mentioned. The entorhinal input into this area is different in three ways. Firstly the projection originates from layer III of the

entorhinal cortex rather than layer II. Second is that the transverse terminal location of the input depends on its medial/lateral origin in the entorhinal cortex. This is in contrast to the dentate gyrus/CA3 projection where the lateral portions of the entorhinal cortex project to the more superficial layers of the stratum lacunosum-moleculare whereas the medial portion terminates in more deep layers. Therefore a more proximal CA1 pyramidal cell (close to CA3) is more likely to be connected to a more medial location in the entorhinal cortex. Finally, the connection to the entorhinal cortex appears to be reciprocal in CA1, whereas in CA3 (and the dentate gyrus) the flow of information is unidirectional (Naber *et al.* 2001). As already mentioned the reciprocal connection between the hippocampus and septal nuclei is present in CA1 also. The amygdala also has significant reciprocal connections with the CA1 area in the more ventral portions (Pitkänen *et al.* 2000). The dorsal raphe and locus coeruleus innervate CA1 less strongly when compared to CA3 (Samuels and Szabadi, 2008). A dopaminergic projection from the ventral tegmental area to the ventral portions of CA1 has also been described (Gasbarri *et al.*, 1994 and 1997).

As the CA1 area gives way to the subiculum the defined laminar structure of the hippocampus breaks down into a more diffuse organisation. The stratum lacunosum-moleculare of CA1 is replaced by the superficial molecular layer, with the deep molecular layer joining the stratum radiatum. The pyramidal cells of the subiculum are also more diffusely distributed and there is no stratum oriens. CA1 projects to the deep molecular layer while the entorhinal cortex layer III neurones project to the more superficial layers. The CA1 to subiculum connection is organised in a proximal-to-distal fashion, this means that the distal portions of CA1 project proximally to the subiculum and *vice versa* (Tamamaki *et al.*, 1987). Again in the subiculum numerous associational connections exist. Interestingly there seems to be a unidirectional flow of information toward the ventral subiculum through these associational connections, in that each pyramidal cell projects to other cells ventrally but not dorsally (Harris *et al.* 2001). The subiculum, along with CA1 can be thought of as one of the major output structures of the hippocampal processing loop, both structures have significant outputs into layer V of the entorhinal cortex. The amygdala has reciprocal connections with the subiculum, with the projection from the amygdala terminating in the proximal molecular layer throughout the dorso-ventral axis. Interestingly only the ventral subiculum appears

to project back toward the amygdala (Pitkanen *et al.* 2000). As with all other parts mentioned above - the septal nuclei appear to have reciprocal connections with the subiculum, also present however is a unidirectional projection to the nucleus accumbens (Kelley *et al.* 1982). There are also a variety of hypothalamic, thalamic and direct cortical projections arising from the subiculum.

The direct connection between the ventral subiculum and the nucleus accumbens has been suggested to play a pivotal role in the selection of goal directed behaviour. In their model, Sesack and Grace (2010) propose that the hippocampus and prefrontal cortex compete for control over the NAc. The release of dopamine in the NAc is proposed to shift the balance of control to favour the hippocampal control through actions on the D1/D2 receptors located on the medium spiny neurones of the NAc itself (Sesack and Grace, 2010).

The intrinsic connections of the hippocampus are summarised in Figure 1.3. As can be seen from the Figure the highly ordered structures described above results in the topographical conservation of entorhinal inputs. Layer II neurones from the medial entorhinal cortex project, via the ventral hippocampal processing loop, to medially located entorhinal layer V neurones. This fact is significant when one considers that the lateral and medial entorhinal cortex receive projections from different brain areas. This has led to the idea that there may be a functional separation within the hippocampus along the dorso-ventral axis. Another striking feature of this structure is the serial/parallel nature of the connections. An individual CA3 neurone for example, may receive the same signal monosynaptically direct from the entorhinal cortex or di-synaptically via the dentate gyrus. Likewise, neurones in CA1 receive projections direct from the entorhinal cortex but also tri-synaptically through the dentate gyrus and CA3.

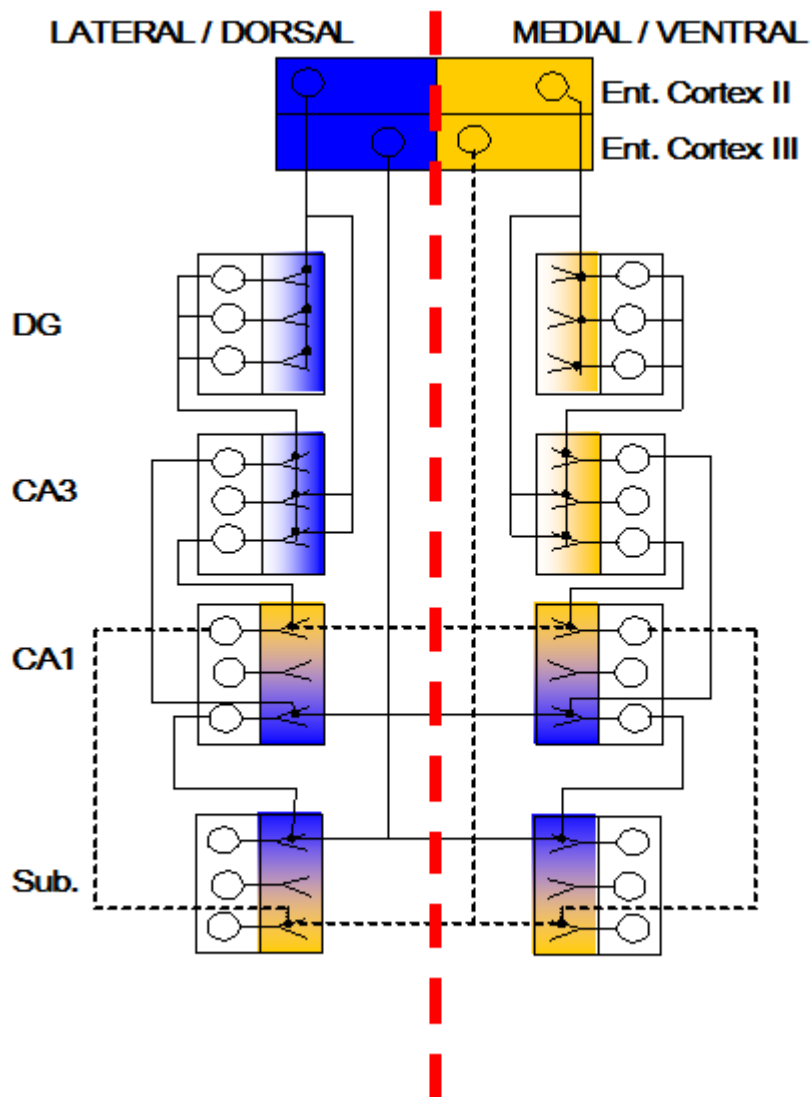

Figure 1.3 A diagram summarising some of the intrinsic connections in the hippocampus.

For clarity some lines are dashed, this is not indicative of any difference in the projection as they are all glutamatergic. There is a complex transverse and dorsoventral organisation within the hippocampus. Studying the diagram reveals that it is likely that different transverse or dorsoventral locations within any hippocampal sub region receives a unique combination of processed information from different hippocampal regions. This is of relevance when combined with the fact that different brain regions project selectively to the lateral or medial entorhinal cortex (Ent. Cortex), as well as the fact that different transverse and dorsoventral locations in the subiculum (Sub.) project to different brain regions. DG = dentate gyrus

Not yet mentioned in any of the above descriptions of anatomical connectivity is the significant number of inhibitory interneurons present in all of these structures. Historically, the role of these GABAergic neurons was thought to be the inhibition of over-excitability during the integration of information by excitatory transmission. It is now clear however, that these interneurons play a fundamental role in many aspects of signal integration as well as synchronising population activity to create the characteristic electroencephalographic signals of the hippocampal theta wave (discussed below). The wide variety, as well as problems in the classification of these interneurons, puts a review of them outside the scope of this work, and they will be mentioned only where appropriate.

1.5.3 Functions of the hippocampus

In the following sections an attempt is made to define the role of the hippocampus. As will become clear, the attempt to define a specific function of any particular brain region belies the vastly interconnected and interdependent nature of the brain. This does not mean that the attempt to investigate hippocampal function is without use however, and by studying the physiology of the hippocampus in awake animals insights can be gained regarding behavioural correlates of neuronal activity. The hope is that one day we may be able describe the information integrated by a particular group of neurons. It is unlikely that the neurons contained within our current definition of the hippocampus are both necessary and sufficient for any one particular behavioural construct.

The removal of the medial temporal lobe in patient HM in an attempt to relieve him of severe epilepsy marked the beginning of a new era in the study of brain function. The finding that HM had impaired memory for facts or faces, while seemingly continuing to perform normally (or even slightly better) in procedural memory tasks (such as learning to draw in a mirror) first suggested that multiple memory systems exist in the brain, and that these could be dependent on different structures (Milner, 1962).

There is a temptation (as a reductionist) to therefore attempt to ascribe a particular function to a particular part of the brain. Upon attempting to do this, two problems become immediately apparent. The first problem is defining the brain region that is

both necessary and sufficient for that particular function. Take the hippocampus for example. It appears from the anatomy that the main excitatory connections through the dentate gyrus, hippocampus proper and subiculum could form the definition of the brain region. The normal physiological function of these brain regions however, depends heavily on the modulatory input from the septal nuclei and other sub cortical structures. In order for the hippocampus to perform its function this modulation must be present and so the rest of the sub-cortical areas involved in the modulation of the hippocampus must be included if we are to arrive at a structure that is both necessary and sufficient for a particular function. So the problem of the extensive interconnectivity in the brain leads us rapidly to defining structures that encompass areas so large and diverse that the definition is of little use.

The second problem is in defining a particular behavioural construct that is of relevance to the way the brain processes information. Behavioural constructs thought to be affected during addiction such as impulse control or motivation may not have single cellular mechanisms within the brain. Another is the measurement of behaviour as an output of brain processing. This is limited by the fact that certain areas of the brain will be necessary for the expression of the measured behaviour while playing little role in the process of interest. To take an extreme analogy - in the conditioned place preference model the motor cortex (and even the animal's legs) could all be seen as necessary in the expression of preference, while playing little part in the real mechanism of interest (the development of preference for one particular environment as a result of repeated paired US and CS).

So if the measurement of behavioural constructs is limited by poor definition of constructs and problems with expression, then defining a function based on the processing of information must be used. Since currently we have a very limited understanding of the precise information being transmitted in many brain regions, we are then limited to basic descriptions of their connectivity (the anatomy, already described). The attempt to define a specific function for one particular brain region therefore leads to the inclusion of unhelpfully large brain structures and/or unhelpfully limited descriptions of function. The solution to this problem is rather than attempting to define a particular structure as performing a certain function,

defining the structure as necessary (or involved in), but not necessarily sufficient for, a particular function. This approach leads to partly useful descriptions of what behaviours the hippocampus plays a role in, while avoiding the potential problems associated with defining a specific function.

Clues from human patients with hippocampal damage

The vast wealth of literature available on human hippocampal lesions including HM, gives rise to an almost indisputable view that the hippocampus is intimately involved in at least some forms of memory (Roy *et al.* 2001). Extensive study of individual patients has well characterised individual deficits (such as HM in Milner, 1962), and studies involving multiple patients with hippocampal damage has identified general patterns in deficits. The lesions performed in humans often vary with respect to their exact extent and often include damage to the adjacent cortical areas (the parahippocampal and perirhinal cortex). It is therefore difficult to draw conclusions about the function of the hippocampal formation specifically from these studies. As a result, although the broad effects of damage to the hippocampal formation and adjacent cortical areas is well characterised, very little is known about the role of specific hippocampal areas. The findings from studies of the role of the hippocampus in humans can be summarised

- The hippocampus and adjacent cortical areas are critically involved in declarative, spatial and episodic memory in a time limited fashion (Milner, 1962; Squire *et al.* 2004).
- Working and implicit memory appear not to be affected by hippocampal and adjacent cortical area damage (Stark and Squire, 2000).
- The hippocampus and adjacent cortical areas are not involved in non mnemonic aspects of cognition. A good example of this is the finding that spatial processing appears to be intact in patients with hippocampal damage. They are able to find novel routes through environments that they have memories of due to them being in the distant past (Teng and Squire, 1999).

Clues from studying *in vivo* physiology in awake rodents

The electroencephalogram (EEG) provides information about the synchronous activity of large populations of neurones, making no distinction between excitatory or inhibitory inputs. While this method has obvious limitations in the study of brain function, the correlation of synchronous activity with certain behavioural outputs does provide glimpses into the roles a particular region may have. Elegant work by Vanderwolf (1969) demonstrated the existence of three major classes of oscillatory activity in the rat hippocampal region. There was a regular, rhythmical oscillation of variable frequency, termed theta. This was correlated to the voluntary movement through an environment. There were also two forms of irregular activity, large and small (LIA and SIA respectively). LIA appeared to occur during behaviours that did not result in the animals movement through its environment (such as eating, grooming etc). SIA appeared to occur during transitions in behaviour such as waking from sleep (Vanderwolf, 1969).

The theta wave can be further divided based on its pharmacological sensitivity into an atropine-sensitive component (a-theta) and an atropine-insensitive component (t-theta) (Kramis *et al.* 1975). This separation reveals that t-theta is correlated with movement through space, possibly increasing in frequency as movement speed increases (Rivas *et al.* 1996; Slawinska and Kasicki, 1998). The behavioural correlate of a-theta is less clear, but appears to be potentiated by high states of attention or arousal (Sainsbury *et al.* 1987). The theta wave is a measurement of the membrane potential oscillations of the pyramidal cells throughout the hippocampus. These oscillations may serve to synchronise population activity across distant brain regions, as theta waves can be observed throughout many limbic structures. Another function of theta waves could be to constrain when plasticity could occur, indeed Hyman *et al.* (2003) found that the same burst pattern delivered at either the peak or trough of theta waves would induce LTP or LTD respectively.

LIA and SIA are much less studied phenomena. LIA oscillations occur during states of low arousal and sleep. They are thought to occur as a result of synchronous firing of CA3 pyramidal neurones, followed by interneurone activity that synchronises the resultant CA1 pyramidal cell firing (Buzsaki *et al.* 1992). Due

to both the behavioural correlates and the likely effect LIAs may have on hippocampal target structures, LIAs have been proposed as a mechanism for synaptic modification of these structures. Put differently, LIAs could represent the consolidation of information transfer from the hippocampus to its target structures. In support of this idea is the finding that cells that fire together during theta phase exploration are more likely to fire together during LIA in sleep (Skaggs and McNaughton, 1996). SIA occurs regularly in the rat during sleep and probably represents the reactivation of the place representation of the place the rat went to sleep (Jarosiewicz and Skaggs, 2004).

While EEG recordings are a powerful way to investigate general functions of populations of cells, they are limited by their resolution. *In vivo* extracellular field recordings allow the recording of smaller populations of neurones or even single-unit recordings if multiple electrodes are used. As early as 1971 this technique was identifying differences in the functioning of neurones *in vivo*. Immediately apparent was that there appeared to be at least two separate populations of neurones, Ranck termed these two types of neurone theta cells and complex spike cells (Ranck, 1973). Theta cells increase their frequency during theta and show strong phase locking to the EEG wave. Complex spike cells show a broader action potential than theta cells with a bursting pattern characterised by steadily increasing duration and decreasing amplitude action potentials. O'Keefe and Dostrovsky (1971) first noted that one of the most powerful predictors of complex spike cell firing was the animal's location in space. This finding led to the development of the cognitive map theory of hippocampal function, an idea still highly influential today (O'Keefe and Nadel, 1978). Other spatially correlated patterns of firing have been both predicted and found in other hippocampal structures, the most recent of which was the discovery of entorhinal grid cells (Hafting *et al.* 2005).

The CA1 pyramidal neurones display place cell properties, meaning they have an increased probability of firing when an animal is in a particular location in space - the 'place field'. Place fields develop rapidly upon entry into a novel environment and are not topographically organised, meaning place cells adjacent to each other are not more likely to have adjacent place fields. Place fields generally increase in size as recordings are taken from progressively more ventral portions of CA1

(Maurer *et al.* 2005). A striking demonstration of place cell encoding was given recently by Ziv *et al.* (2013) who used somatic calcium imaging in behaving mice. Over the period of 45 days place cells remained remarkably stable. It was possible to determine accurately the animal's location in space through analysis of place cell behaviour and animal location on any previous visit to that arena. There is general widespread agreement that spatial processing intimately involves the hippocampus in rodents and this is at least partially supported by studies of humans with hippocampal damage. There is considerably more disagreement as to whether or not place cell firing encodes any sort of motivational signal (either aversive or appetitive). Hollup *et al.* (2001) recorded place fields during performance in a water maze. They found place fields tended to cluster around the goal platform, suggesting that the development of place fields can be modulated by motivational influences. Moita *et al.* (2004) used an aversive electrical stimulation of the eye as the US with either a discrete cue (a tone) or a specific context as the CS. They found that significantly more place fields were altered in the context CS group compared to the tone CS group. Taken together these results suggest that it is at least possible that CA1 place fields are modulated by the presence of salient stimuli in specific locations.

The fact that the hippocampus seems to be involved in the processing of spatial information does not mean that the only function of the hippocampus is spatial processing. Many other theories regarding hippocampal function do exist, such as the role of the hippocampus in stress. While relatively well studied in rodent models, relatively little information regarding the emotional deficits in humans following hippocampal damage seems to be available. Perhaps the profound memory deficits in these patients prevent the expression of any emotional deficit. Also, any depressive like effects seen could easily be dismissed as a result of the profound memory loss. One of the major debates surrounding hippocampal function and stress currently is regarding causality. It is clear that stress can have profound effects on hippocampal function, but it is unclear if stress can be modulated by the hippocampus. A full discussion of this topic is beyond the scope of this work, for a review see Sheline (2011).

The vast majority of studies on rodent hippocampal function have been centred around the role the hippocampus plays in spatial processing. The conclusions from

studies involving humans however, often define the role of the hippocampus in a broader sense, such as playing a role in declarative memory. There are obvious difficulties in studying memory that can be declared in rodents, and so perhaps it is for this reason that studies focus on the spatial aspect. Another possibility is that the human hippocampus is functionally different from that of the rodent. Anatomically the hippocampus is well conserved across all mammals, however the input structures are very different. In humans the massively increased neocortical association areas are likely to deal with a much wider range of complex abstract information than those of the rodent. As already mentioned the hippocampus receives information from across the neocortex via the entorhinal cortex. The information integrated by the hippocampus therefore is likely to reflect the information processed by the neocortex.

The studies described above can give many insights into hippocampal processing but still do not lead us toward a definition of hippocampal function. The definition of hippocampal function that is unlikely to be wrong, but at the same time not particularly useful is that; *the hippocampus combines and extends information processed by adjacent cortical and subcortical regions*. While the exact role of the hippocampus remains to be defined, information flow through it will undoubtedly be affected by addictive substances. As will be discussed later in this work, morphine has direct effects on the GABAergic interneurons responsible for synchronising neuronal activity throughout the hippocampus (the theta rhythm). The dopamine signal generated in VTA target sites by all addictive substances will also have effects on synaptic plasticity in certain parts of the hippocampus (discussed later). These actions will affect both the processing and storage of information by the hippocampus, but this fact alone does not tell what if any addiction-related behaviours are then mediated by the hippocampus.

1.5.4 The functions of the hippocampus of relevance to addiction-related behaviours

So far in this work, the case has been made that drug addiction is a pathology of learning and memory, and that environmental cues can trigger these pathological memories and so instigate drug seeking behaviours. We have also seen that although defining a specific role for the hippocampus is difficult, it seems to be

intimately involved in the processing of sensory information along with many aspects of memory formation. The following paragraphs now examine evidence suggesting that the normal function of the hippocampus is (at least partly) responsible for some addiction-related behaviours.

On a basic level, lesions of the dentate gyrus (the beginning of the hippocampal processing loop) have been shown to completely disrupt both the acquisition and expression of place preference to cocaine (Hernández-Rabaza *et al.* 2008). Temporary inactivation of the dorsal hippocampus can also prevent the expression of place preference behaviour (Meyers *et al.* 2006).

In 2001 Vorel *et al.* demonstrated that patterned stimulation of the ventral subiculum was able to reinstate a previously extinguished cocaine seeking behaviour. This effect was dependent upon context as well as activation of the VTA. It is worth noting that this effect was not exclusively dependent upon VTA-induced NAc dopamine as medial forebrain bundle stimulation (that supports self administration and causes NAc dopamine release) was not able to reinstate this behaviour (Vorel *et al.* 2001). This result suggested that signals generated in the hippocampus could mediate at least some forms of relapse. Ventral subiculum stimulation has also been used successfully to reinstate d-amphetamine self administration behaviour during periods of voluntary abstinence (Taepavarapruk and Phillips, 2003). Taken together these two results strongly suggest that the initiation of drug seeking behaviour can be induced by hippocampal activation.

The role of the hippocampus in the initiation of drug seeking behaviour appears to translate into addicted humans, as craving inducing stimuli increased blood flow to the hippocampus measured using PET (Kilts *et al.* 2001). The ventral subiculum has also been implicated in other addiction-related behaviours, such as in the reinforcing effects of cocaine (Caine *et al.* 2001).

Unilateral lesions of the hippocampus have been shown to disrupt a sucrose-induced place preference when the only available cue was spatial (Ito *et al.* 2006). A functional connection between the hippocampus and the nucleus accumbens may underlie this effect. Ito *et al.* (2008) showed that a unilateral lesion of the hippocampus with contralateral lesion of the nucleus accumbens shell sub region

was able to disrupt a conditioned place preference to sucrose. This connection from the hippocampus to the nucleus accumbens appears to be enhanced by phasic dopamine release in the nucleus accumbens (Gotto and Grace, 2005). As mentioned earlier nucleus accumbens dopamine release is thought to play a central role in goal directed behaviour. This dopamine release therefore may represent a mechanism to allow the hippocampus control over nucleus accumbens output.

The hippocampus, or more specifically the ventral subiculum, may also play a role in controlling the activity of dopamine neurones in the VTA through a complex loop formed by the ventral subiculum, NAc, ventral pallidum (a basal ganglia nucleus) and the VTA (Lodge and Grace, 2006). This system may be the way in which the hippocampus regulates responses to drug predictive cues dependent on recognition of environmental contexts (Grace *et al.* 2007). More recently, an alternative pathway between the dorsal CA3 and the VTA via the lateral septum has been proposed to modulate the same process. Luo *et al.* (2011) showed that injections of GABA agonists bilaterally in CA3 (or contralateral injections into the lateral septum and VTA) blocked context-induced reinstatement of lever pressing.

Summarising the evidence presented in this section, addiction-related behaviours such as place preference or self administration are clearly modulated by the hippocampus. These facts alone do not suggest that the hippocampus would be a good target for intervention however, as these studies do not demonstrate that changes in hippocampal processing underlie these behavioural changes. Evidence that addictive substances can alter hippocampal processing does exist however, but before these studies can be explained, a more in depth look at how information is transmitted through the hippocampus is necessary.

1.6 Synaptic transmission in CA1

The synapse is a specialised area of the neurone where signals in one neurone are passed to another in a process known as synaptic transmission. In synaptic transmission an electrical signal is first transduced into a chemical signal by the first neurone, called the pre-synaptic neurone. This chemical signal is released into a very tight space (2\AA) between the cells (the synaptic cleft) where specialised

receptors on the second cell (the post-synaptic cell) convert this chemical signal back into an electrical one. Figure 1.4 (next page) shows a typical glutamatergic synapse such as those found at the synapses formed between the hippocampal CA3 and CA1 neurones. When an electrical signal (known as an action potential) arrives at the pre-synaptic membrane, voltage-gated calcium channels (VGCCs) open and allow the influx of calcium into the pre-synaptic cell. This can trigger a calcium dependent exocytosis of neurotransmitter (in this case glutamate) into the synaptic cleft. This neurotransmitter is then free to diffuse across the synaptic cleft where it can bind with ionotropic and metabotropic receptors on the post-synaptic membrane. The opening of ionotropic receptors allows the movement of ions down their electrochemical gradient. The result of this flow of ions can either be a depolarisation or a hyperpolarisation of the post-synaptic membrane, dependent on the electrochemical potential of the ion conducted. At the glutamatergic hippocampal CA3-CA1 synapse, the opening of ligand-gated cation channels depolarises the membrane. If the depolarisation of the post-synaptic membrane is great enough then voltage-gated sodium channels open and an action potential may be triggered along the axon causing the release of neurotransmitter from the axon terminals (Stuart *et al.* 1997).

The presynaptic specialisation can be identified in electron micrographs as a thickening in the membrane with vesicles of similar size clustered behind it. The membrane thickening is thought to represent the 'active zone' containing voltage-gated calcium channels and all the necessary proteins for SNARE mediated exocytosis. Postsynaptic specialisations for so called 'asymmetrical synapses' include a thickening of the membrane and an electron dense area known as the postsynaptic density (PSD). 'Symmetrical synapses' lack this PSD and are often found around the soma and axon hillock of the pyramidal cells of CA1. It is generally thought that asymmetrical synapses are excitatory while symmetrical synapses are inhibitory. The principal excitatory and inhibitory neurotransmitters in CA1 are glutamate and GABA respectively. The exocytosis of neurotransmitter into the synaptic cleft may occur via one of two mechanisms, 'full fusion' and 'kiss and run'. Identifying what type of exocytosis occurs at a synapse is technically challenging and very little specific information regarding CA1 is available. There is evidence from cultured hippocampal cells that this mode of vesicle release can be regulated however (Regner *et al.* 2001). The changes in kinetics of

neurotransmitter release can have a significant impact on neurotransmission due to rapid diffusion and re-uptake of neurotransmitter from the synaptic cleft (discussed later).

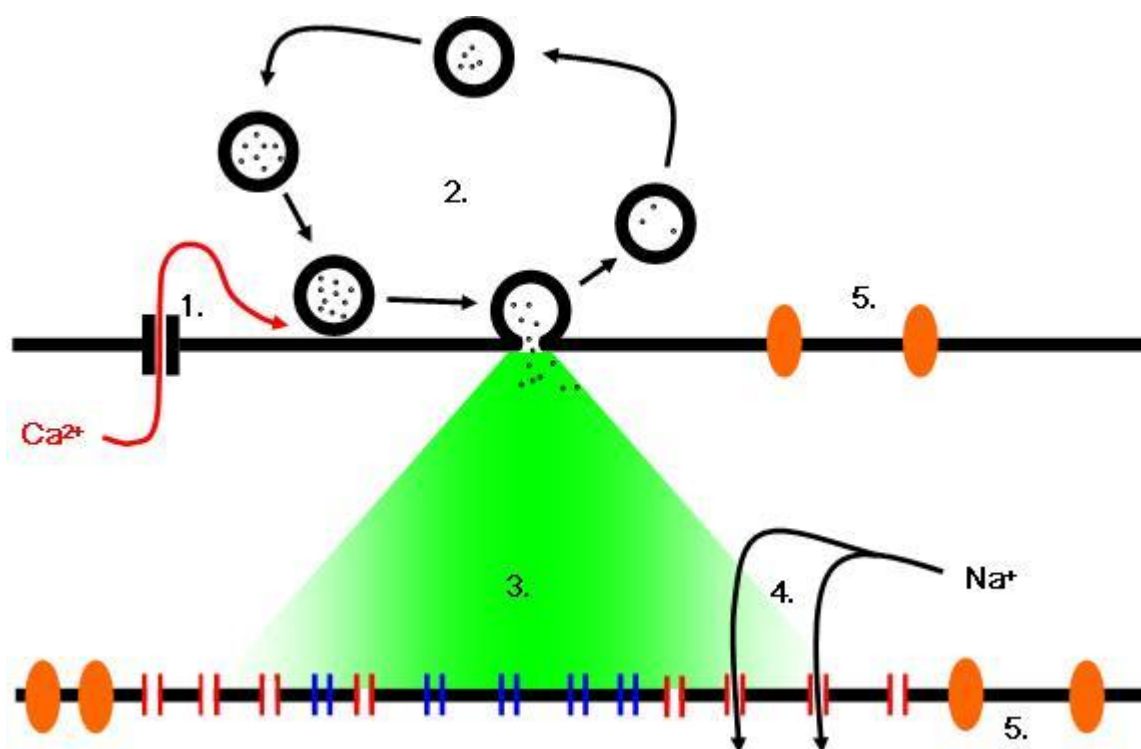

Figure 1.4 Synaptic transmission at a glutamatergic synapse.

1. Depolarisation of the presynaptic membrane (top) causes the opening of voltage-gated calcium channels. 2. The rise in intracellular calcium triggers SNARE mediated endocytosis and the release of glutamate into the synaptic cleft. 3. Glutamate can bind to ionotropic AMPA (red) and NMDA channels (blue). 4. AMPA channels are permeable to Na⁺ ions which flow down their electrochemical gradient and depolarise the postsynaptic membrane (bottom). 5. Also present on both pre- and postsynaptic membranes are GPCRs that regulate cell excitability and transmitter release.

Neurotransmitter released into the synaptic cleft can act on two principal types of receptors. Ionotropic receptors couple ligand binding to the opening of ion permeable channels. Metabotropic receptors (GPCRs) couple ligand binding to intracellular signalling cascades through the dissociation of GTP-binding proteins (G-proteins).

There are three major classes of ionotropic glutamate receptors, classified according to their sensitivity to experimental compounds. They are named AMPA, NMDA and kainate receptors. Kainate receptors are the least studied class of receptors and have complex physiological roles, mainly in the modulation of synaptic transmission rather than being involved directly in synaptic transmission itself (Jane *et al.* 2009). In the hippocampal CA1 area the highest expression of kainate receptors is in pre-synaptic CA3 nerve terminals and on GABAergic interneurons (Jane *et al.* 2009). Due to their poorly understood role in synaptic plasticity and limited evidence for their involvement in drug addiction they are not discussed further. AMPA receptors are hetero or homotetrameric assemblies of highly homologous sub-units named GluR1-4 (Anggono and Huganir, 2012). The trafficking of AMPA receptors is highly dynamic and regulated by sub-unit specific interacting proteins as well as post-translational modifications to the c-terminal domain. NMDA receptors are heterotetrameric assemblies of diverse sub-units named NR1-3. While historically seen as a less dynamic population of receptors (Wenthold *et al.* 2003), it is now apparent that NMDA receptor function and trafficking is also dynamically regulated (for a review see Hunt and Castillo, 2012).

The generation of an action potential is dependent on the depolarisation of the membrane around an area called the axon hillock. Therefore the depolarisation at the post-synaptic membrane must spread up the dendrite and through the soma to reach this area. In fact the probability of a single synaptic event triggering an action potential in the post synaptic membrane is actually very small, and many synaptic events must occur in quick succession if the depolarisation is to reach the axon hillock. As mentioned earlier, synaptic transmission can result in either an excitatory depolarisation or inhibitory hyperpolarisation and it is therefore the sum of these events that can increase or decrease the chances of the action potential being transmitted - for this reason this process is called summation (Piskrowski and Chevaleyre, 2012). As well as depolarising and hyperpolarising influences, pre-synaptic activity can control action potential transmission from second to second through second messenger systems. These can have effects on the ligand-gated ion channels as well as voltage-gated channels (Betke *et al.* 2012). It is worth noting that these excitatory and inhibitory currents do not summate in a linear fashion. Voltage-gated conductances on the dendritic membrane are more likely to be triggered by local summation of EPSCs than by EPSCs occurring

distally from one another. The action of inhibitory IPSCs is also dependent on location. IPSCs not only hyperpolarise the membrane but also decrease the membrane resistance. IPSCs can therefore shunt generated EPSCs out of the dendrites preventing the spread of depolarisation reaching the soma from where action potentials are generated (Stuart *et al.* 1997).

Longer-term modifications to synaptic efficacy also occur via a plethora of mechanisms, and are referred to collectively as synaptic plasticity. These changes can last from seconds to months and possibly longer *in vivo* (Abraham, 2003) and are the focus of the following section.

1.7 Mechanisms of synaptic plasticity in CA1

Synaptic plasticity describes the process by which the efficiency of signal transduction between pre- and post-synaptic cells is either increased or decreased. The term, first coined by Konorski (1948) has long been postulated as a cellular basis for information storage. The first complete theory of how synaptic plasticity could be utilised by the brain to store information was presented by Hebb (1949). In his theory, coincident activation of the pre- and postsynaptic neurone led to the connection between these two neurones being strengthened. The startling similarities between his model and the type of long-term synaptic plasticity discovered nearly 25 years later (Bliss and Lomo, 1973), has led to the coining of term Hebbian-synaptic plasticity. Hebbian, as well as some other forms of synaptic plasticity, are now thought by many to be a cellular correlate of memory (Bliss and Collingridge, 1993). The study of synaptic plasticity has become such a large field in the intervening 40 years that a comprehensive review of the literature is beyond the scope of any single work. Given that the majority of investigations into synaptic plasticity have taken place in the hippocampal CA1-CA3 synapse, and that this is also the target of the current investigation, only those studies involving CA3-CA1 are mentioned here. Changes in synaptic transmission that result from specific patterns of stimulation have been studied now for 40 years, but despite this several fundamental questions regarding the nature of this change remain unanswered. One such debate revolves around the locus of the change, it being either pre- or postsynaptic. Evidence in favour of both arguments is presented here.

1.7.1 NMDAR-LTP

The CA3-CA1 synapse is a glutamatergic synapse expressing two major types of ionotropic receptor, AMPAR and NMDAR. The process begins with activity in the presynaptic terminal causing the release of glutamate. The ligand bound AMPAR in its open state is permeable to cations (mostly sodium and potassium) and so the net result is a flow of sodium ions into the cell. The ligand bound NMDAR is blocked in a voltage-dependent manner by extracellular magnesium ions and so at the resting membrane potential no current flows through these. If the postsynaptic membrane becomes depolarised enough then the magnesium block is relieved and current flows through the ligand bound NMDAR. The NMDAR is also a non-specific cation channel but it has a much higher permeability to calcium, and so the intracellular concentration of calcium then rises. This calcium signal may induce a series of complex and sometimes parallel signalling cascades that ultimately result in an increase (or sometimes a decrease) in synaptic efficacy (Lisman and Raghavachari, 2006). Initially these signalling cascades are dependent on the activity of various kinases (probably most significantly CaMKII) but then over a period of hours the mechanism also becomes dependent on protein synthesis. NMDAR-LTP can therefore be split into two major processes based on its pharmacological sensitivity. The long lasting form known as late-LTP (L-LTP) can be blocked by the use of protein synthesis inhibitors. CA1 neurones in hippocampal slices will revert back to baseline EPSC measurements in around 5 to 6 hours under these conditions (Frey *et al.* 1988). Early-LTP (E-LTP) is sensitive to the inhibition of protein kinases and seems to maintain LTP up until L-LTP is apparent. Weak stimulations can sometimes produce E-LTP without inducing L-LTP. No stimulus protocol has yet been found that induces L-LTP without inducing E-LTP first, although application of certain compounds can. It appears therefore that E-LTP is a prerequisite of L-LTP during activity dependent plasticity. One last important note is that E-LTP and L-LTP are not necessarily temporally distinct, in that the protein synthesis phase of L-LTP can occur immediately after the LTP inducing stimulus (Lisman and Raghavachari, 2006).

Induction Protocols

There are a number of ways to induce long lasting changes in synaptic efficacy in an NMDAR-dependent manner, but it appears that not all of them do so by the same mechanism. With extracellular recordings there are two general categories of induction protocol, the high intensity methods and the theta-type methods. The high intensity methods vary from brief 400 Hz stimulation (Douglas and Goddard, 1975) to extended periods of 1 Hz stimulation at a very high intensity in the presence of picrotoxin (Abraham *et al.* 1986). The most widely used of these methods is probably a train of 100 pulses delivered at 100 Hz. It is difficult to imagine an activity pattern of 100 Hz for 1 second occurring during the normal physiological function of the hippocampus, certainly no patterns of activity like this have ever been observed in healthy animals. Two of the more physiologically relevant protocols (the theta type methods) are known as primed burst stimulation (PBS) and theta burst stimulation. The common principle behind these methods is a gap of around 200 ms between stimulations. This idea is based on the observation that the first stimulation of the efferent fibre results in both the release of glutamate and GABA, GABA_B auto-receptors on the GABAergic inter-neurons act to reduce transmitter release with a maximal effect at around 200ms post-stimulation (Davies *et al.* 1991). The role of GABA receptors, both ionotropic (GABA_A) and metabotropic (GABA_B) has been well documented in CA1. The IPSC generated coincidentally with the EPSC serves to shorten the amount of time the post-synaptic membrane remains depolarised. The effect of this is the decreased sensitivity to temporal summation as shown by the effects of GABA_A inhibition (Dingledine *et al.* 1986). The second train of impulses arrives at this peak of GABA auto-inhibition. This protocol therefore makes use of the hippocampal theta generation mechanisms to increase the temporal summation of the presynaptic signal and can therefore be thought of as more physiologically relevant. The induction protocol used is relevant as different mechanisms may be activated by different patterns of activity. At the extreme end of this argument is the fact that certain activity patterns can depress instead of potentiate synaptic efficacy, but different mechanisms may also be responsible for NMDAR-LTP depending on stimulation protocol as will be shown in the following sections.

Factors influencing the generation of the calcium signal

The activation of the NMDAR and entry of calcium ions through its pore is the defining mechanism of NMDAR-LTP. The NMDA receptor displays a strong voltage-dependence due to pore-block by extracellular magnesium ions. These ions are driven away from the pore at depolarised membrane potentials, allowing the influx of both sodium and calcium into the neurone (Mayer *et al.* 1984; Nowak *et al.* 1984). As these channels are also ligand-gated, the conditions necessary for current to flow through the NMDA receptor are; a sufficiently depolarised post-synaptic membrane, and the presence of glutamate in the synaptic cleft. Therefore the NMDAR requires coincident pre- and postsynaptic activity. Hebb's coincidence detector.

As mentioned above, the NMDA receptor is unusual amongst the ligand-gated ion channels in that it is permeable to calcium. Since intracellular calcium is required for the induction of NMDAR-LTP in the hippocampus (Lynch *et al.*, 1983) it seems reasonable to assume that the entry of calcium through the NMDA receptor could be the trigger for LTP. There are other sources of intracellular calcium however. A second major source of intracellular calcium is from intracellular stores, through the actions of IP_3 on IP_3 receptors, or through calcium-induced calcium release mediated by ryanodine receptors. Depletion of these intracellular stores has been shown to inhibit NMDAR-LTP (Harvey and Collingridge, 1992) and augment the NMDA receptor dependent calcium signal in post-synaptic neurones after tetanic stimulation (Alford *et al.* 1993). The relevance of this alternative source of calcium in physiological changes in synaptic strength is unclear, however its dependence on NMDA receptor activation means that it does not detract from the critical role of the NMDA receptor. A third major source of intracellular calcium could be through depolarisation-induced activation of voltage-gated calcium channels. If entry of calcium through these voltage-gated channels was an alternative method of induction of LTP, then depolarisation (through voltage-clamp) in the absence of pre-synaptic activity would be expected to induce widespread LTP across many synapses independent of pre-synaptic activation. It appears that stable LTP can only be produced when protein-phosphatases are also introduced into the intracellular medium, suggesting that under physiological conditions voltage-gated

calcium entry does not play a significant role in the induction of LTP (Wyllie and Nicoll, 1994).

The role of metabotropic glutamate receptors (mGluRs) in the induction of NMDAR-LTP is complex and incompletely understood. Group I mGluRs are expressed post-synaptically and couple to G_q proteins that activate phospholipase C (PLC). PLC activity produces IP_3 that can act to release intracellular calcium, therefore mGluR activation targets a mechanism common to NMDAR-LTP. The activation of mGluRs during NMDAR-LTP has been reported to be a requirement for the induction of LTP (Bashir *et al.* 1993). In other studies however the same antagonist (MCPG) appears to have no effect (Manzoni *et al.* 1994; Martin and Morris, 1997). These conflicts can be reconciled by the finding that activation of mGluRs can occur minutes before the LTP induction protocol rendering NMDAR-LTP independent of mGluR activation (Bortolotto *et al.* 1994). One study found that activation of mGluRs alone (with ACPD) was sufficient to trigger NMDAR-LTP independent of pre-synaptic stimulation or NMDAR activation (Bortolotto and Collingridge, 1993). There have also been reports that the selective mGluR agonist DHPG can induce a form of synaptic depression (Naie and Manahan-Vaughan, 2005; Palmer *et al.* 1997). So while NMDAR-LTP may be dependent on mGluR activation, pharmacological activation of mGluR can result in LTP or LTD depending on the experimental conditions. These findings may be reconciled by the observation that pairing weak pre- and post-synaptic activity with application of DHPG can switch the depression into a potentiation (Kwag and Paulson, 2012). Therefore mGluR activation could result in a weak calcium signal that under the correct conditions could produce LTD, whereas the small additional rises in intracellular calcium as a result of weak stimulation could be sufficient to induce LTP. The role of mGluR activation in NMDAR-LTP therefore is complex and may depend on the history of activation at that particular synapse as well as the strength of the presynaptic signal.

Induction involves the activation of multiple kinases

The postsynaptic intracellular signalling cascade that follows LTP induction is extremely complex with numerous kinases implicated in both early and late LTP.

This section will briefly review the evidence for the role of CaMKII, PKA, PKC, MAPK, tyrosine kinase and IP3K in both early and late LTP.

Perhaps of all the kinases involved, CaMKII could be seen as playing a central role. CaMKII is a large holoenzyme made from twelve homo- or heteromeric subunits. There are two major forms of the subunit, α and β . One calmodulin molecule can bind each subunit in a cooperative manner, this binding removes the regulatory domain from the kinase domain and activates the enzyme. A relatively slow process of autophosphorylation also occurs between adjacent calmodulin bound subunits, this process greatly increases the association between CaMKII and calmodulin and converts the enzyme into an autonomous state. This autonomous state allows CaMKII activity to persist long after the calcium signal has been removed (Lisman *et al.* 2012). If a constitutively active form of CaMKII is introduced into CA1 neurones then an LTP-like effect is observed, and this effect occludes further synaptically induced LTP (Lledo *et al.* 1995; Pi *et al.* 2010). If the autophosphorylation site in CaMKII α (the major subunit found in the dendrites) is mutated to prevent the enzyme entering its autonomous state, then the induction of LTP through stimulation is prevented (Giese *et al.* 1998). While the central role of CaMKII is well accepted, other CaMKII independent forms of NMDAR-LTP can occur, such as early in development when cAMP-dependent kinase appears to play the central role (Yasuda *et al.* 2003). Taken together, these results suggest that CaMKII activation is both necessary and sufficient for the induction of at least some forms of LTP.

The role of cAMP-dependent kinase (PKA) is much less clear. Studies find varying results of PKA inhibition ranging from complete inhibition of L-LTP while sparing E-LTP (Matthies and Reymann, 1993; Huang and Kandel, 1994; Duffy and Nguyen, 2003), to no effect (Bortolotto and Collingridge, 2000). One study (Huang and Kandel, 1994) found that while some stimulation patterns resulted in PKA insensitive E-LTP, other stronger patterns of stimulation resulted in L-LTP that was dependent on PKA activation. Consistent with a role for PKA in L-LTP is the observation of a steadily increasing EPSP following PKA activation that occludes further NMDAR-LTP induction (Duffy and Nguyen, 2003). Interestingly, there appears to be significant strain differences among mice in the ability of PKA to influence L-LTP (Nguyen *et al.* 2000). Reviewing these studies leads to the

conclusion that PKA has varying importance in LTP induction, ranging from a critical role in L-LTP to apparently having no effect. This may be dependent on both the strain as well as the age of the animal.

Perhaps the first kinase to be identified as playing a role in LTP was PKC (Lovinger *et al.* 1987). There are a number of PKC isoforms that can broadly be split into the conventional, novel and atypical forms (cPKC, nPKC and aPKC respectively). The activation of cPKC requires DAG and intracellular calcium ions, whereas nPKC can be activated independently of calcium ions. aPKCs are independent of both DAG and calcium (Sacktor, 2008). Therefore PKC could be expected to be activated by mGluR stimulation alone or through co-activation of NMDA and mGluR. In some studies in fact, PKC inhibition can abolish the effects of mGluR activation on synaptic plasticity (Bortolotto and Collingridge, 2000). In other studies, normal LTP is abolished in mutant mice lacking the cPKC isoform PKC γ . LTP can be restored in these mice if a low frequency LTD inducing protocol is given prior to the LTP induction, although this effect is not dependent on the induction of LTD (Abeliovich *et al.* 1993). These results are consistent with a role for PKC in mediating mGluR modulation of LTP. PKC has also been shown to induce LTP independent of any stimulation protocol when activated by phorbol esters, although non-specific effects on vesicle release may account for this effect (Kazanietz *et al.* 2000). There is also evidence that PKC phosphorylation of GluR1 may control synaptic insertion of AMPARs during LTP (Boehm *et al.* 2006). To summarise these results, PKC appears to be intimately involved with many aspects of synaptic plasticity although further work is needed to clarify its precise role.

The MAP kinase signalling cascade has also been implicated in LTP, but only under some stimulation protocols (Opazo *et al.* 2003). This finding suggests that the role of MAPK may be regulatory rather than directly modulating a critical induction mechanism. MAP kinases are part of a long signalling cascade that is responsible for signal transduction to the nucleus and can be regulated by both PKA and PKC. It would therefore be expected that the target of MAP kinases would be part of the L-LTP mechanism, however effects on AMPAR trafficking and potassium channel regulation have also been observed (for a review see Sweatt, 2004). Another regulator of the MAP kinase cascade is PI3 kinase. PI3K has also

been implicated in the induction of LTP through effects on MAP kinase but also through more direct mechanisms (Opazo *et al.* 2003).

Lastly, the non-receptor tyrosine kinases fyn and src have been shown to be involved NMDAR-LTP. Knockout mice are incapable of expressing LTP (O'Dell *et al.* 1991) at least under some induction protocols in mature animals (Kojima *et al.* 1997). The role of these src-family tyrosine kinases could be modulation of the NMDAR (Li *et al.* 2011).

To summarise, it appears that the activation of CaMKII plays a central role in the induction of NMDAR-LTP. A multitude of other kinases regulate this central mechanism, and some also take part in parallel signalling cascades that under certain conditions can induce LTP independent of CaMKII. The large amount of modulation and interaction between these various signalling mechanisms that ultimately result in the same outcome suggests that intracellular kinase cascades may play a role in the further integration of information. If this were true then accurate neural network simulations would have to take this into account, adding a great deal of complexity to an already complex field.

E-LTP expression mechanisms

There are three obvious mechanisms by which NMDAR-LTP could be expressed. Firstly, the amount of neurotransmitter released per presynaptic impulse could increase. This would obviously involve changes in the presynaptic cell such as changes in release probability and/or quantal size. The second way involves the postsynaptic cell becoming more sensitive to the neurotransmitter released by the presynaptic neurone. This could involve changes in the density of AMPARs in the postsynaptic membrane and/or alterations in the function of AMPARs. The later possibility is through the creation of more synapses through either pre- or postsynaptic mechanisms (or both). The locus of expression of NMDAR-LTP was the focus of intense debate for over a decade around the 1990s, and the arguments suffered somewhat from polarisation. While a wealth of data supports the view that post-synaptic changes do in fact occur, there is more limited evidence for changes in pre-synaptic function (Malenka and Bear, 2004). The amount of available evidence for a mechanism however is not correlative of the

relative importance of that mechanism. For instance, there are significantly greater technical challenges in the measurement of presynaptic changes that could be partly responsible for this imbalance, also the highly polarised debate has led to review articles selectively referencing in favour of a particular stance. The view taken here is one that assumes that both pre- and postsynaptic changes could occur, as there is evidence supporting both ideas. These mechanisms are not necessarily mutually exclusive.

As mentioned above, changes in the postsynaptic cell would be expected to result in an increased sensitivity to neurotransmitter. Indeed this seems to be the case, as exogenously applied AMPA has a significantly greater effect after the induction of stimulus-induced LTP (Davies *et al.* 1989). The increased response to a crudely applied ligand depends on not only synaptic but also extrasynaptic receptors, and so it is possible that this result could be of little relevance to synaptic transmission. In an attempt to address this problem, Matsuzaki *et al.* (2004) used photolysis of caged glutamate to measure the responsiveness of single dendritic spines. After an induction protocol that involved repetitive stimulation of a dendritic spine paired with a solution lacking magnesium ions, an LTP-like process caused an increase in the AMPAR-mediated current (Matsuzaki *et al.* 2004). As already mentioned, there are two proposed mechanisms for this increased sensitivity during NMDAR-LTP; an increase in the amount of current conducted by individual AMPA receptors (the conductance) through post-translational modification or changes in the stoichiometry of AMPARs and/or an increase in the number of functional synaptic AMPA receptors through modifications in trafficking, or changes in the conduction of EPSPs from the dendrites to the soma.

There have been a number of reports suggesting that post-translational modification of AMPARs does occur during NMDA-LTP. Alterations in the amount of current conducted by a single AMPAR are dependent on a number of factors including; the open probability of the channel in its ligand bound state (P_o), the activation/deactivation kinetics and the single channel conductance. There are limited reports of changes in receptor kinetics in CA1 (Kolta *et al.* 1998) although there are conflicting reports (Rammes *et al.* 1999). A significant difference between these reports is the method of induction - whereas Rammes *et al.* (1999) used the 100Hz method, the other study (Kolta *et al.* 1998) used theta type stimulation. As

already mentioned the AMPA receptor contains numerous sites for phosphorylation by various kinases, many of which have been implicated in NMDAR-LTP. Regulation of both trafficking and function by phosphorylation is a common mechanism among neuronal ion channels, and the AMPA receptor appears to be no different. Both PKC and CaMKII may phosphorylate GluR1 S831, and S845 can be phosphorylated by PKA to increase P_O (Roche *et al.* 1996; Kristensen *et al.* 2011). These phosphorylation sites appear to be a requirement of stable LTP, as in double mutant mice lacking phosphorylation at either of these residues LTP is augmented (Lee *et al.* 2003; Lee *et al.* 2010).

There has been considerably more interest in the role that an increase in receptor number plays in NMDAR-LTP and for the most part the expression mechanisms are reasonably well defined. AMPA receptors are quickly recycled at peri-synaptic sites under normal conditions, through the classical pathways of SNARE-mediated exocytosis and dynamin/clathrin mediated endocytosis. In fact, inhibiting endocytosis leads to a gradual increase in the stimulated EPSC amplitude (Lüscher *et al.* 1999). The trafficking (and function) of AMPA receptors in the post synaptic density is tightly controlled by a group of proteins known as transmembrane AMPA receptor regulatory proteins (TARPs). One such TARP, called stargazin has the ability modify the lateral diffusion of AMPARs by anchoring within the PSD and thus alter the number of receptors present at any one time (Bats *et al.* 2007). Stargazin is tightly bound to the AMPA receptor and contains a binding site for the synaptic scaffolding protein PSD-95, the affinity of which may be controlled by CaMKII or PKC phosphorylation (Tomita *et al.* 2005). There is also increasing acceptance that the NMDAR may be upregulated during NMDAR-LTP also (Peng *et al.* 2010, Hunt and Castillo, 2012).

Evidence that a change in the stoichiometry of AMPARs may happen during NMDAR-LTP in the hippocampus is controversial. Under basal conditions in CA1 neurones very few AMPARs lack the GluR2 subunit that prevents calcium from passing through the pore. GluR2 -lacking AMPARs display inward rectification due to endogenous polyamine block, an effect often used to test for the presence of these channels by the inclusion of spermine in the pipette solution. While there have been conflicting reports (Adesnik and Nicoll, 2007; Gray *et al.* 2007) the evidence is probably in favour of GluR2-lacking receptors being present after

induction of NMDAR-LTP (Plant *et al.* 2006; Moulton *et al.* 2010; Guire *et al.* 2008, Rozov *et al.* 2012), at least under some conditions.

Expression of post-synaptic NMDAR-E-LTP is therefore a result of numerous mechanisms that depend not only on the specific stimulation that induces it, but also on the developmental stage of the animal.

L-LTP Expression/maintenance mechanisms

Late-LTP is the phase of LTP sensitive to protein synthesis inhibition as already mentioned and also often involves morphological changes to the synapse. The depth of understanding of L-LTP is much less than for E-LTP, probably because of the long and stable recordings required to observe the mechanism (typically around 6-12 hours). Also, the fact that L-LTP is dependent on E-LTP means that elucidating the role of kinases that are involved in both E-LTP and L-LTP is challenging.

Krug *et al.* (1984) were the first to demonstrate that protein synthesis inhibition could disrupt the late forms of LTP *in vivo* in the dentate gyrus. This effect also occurs *in vitro* in the CA1 area (Frey *et al.* 1988). This mechanism is likely to involve both local protein synthesis within the dendrites as well as within the soma. Evidence in support of local dendritic protein synthesis comes from the finding that a form of L-LTP induced in isolated dendrites is sensitive to protein synthesis inhibitors (Frey *et al.* 1989) and that local apical dendritic application of protein synthesis inhibitors can selectively inhibit L-LTP in that region whilst basal dendritic synapses seemed unaffected (Bradshaw *et al.* 2003). In support of the idea that dendritic protein synthesis occurs is the rough endoplasmic reticulum observed in electron micrographs of dendritic spines, and the finding that there are ~400 different mRNAs estimated to be in the dendrites of cultured pyramidal cells (Eberwine *et al.* 2001). As already mentioned however, local dendritic synthesis is unlikely to be wholly responsible for L-LTP. For LTP to display associativity (strengthening of a weak input when temporally paired with a spatially separated strong input) some form of signal must be passed from the strongly activated synapse to the weakly activated one. The only logical way for this to happen would be via the nucleus. In support of this idea is the observation that transcriptional

inhibitors can block L-LTP *in vitro* in CA1 (Nguyen *et al.* 1994), and immediate early genes such as *zif268* and *arc* may be upregulated in response to LTP inducing stimulation (Roberts *et al.* 1996; Granado *et al.* 2008). Critical to the induction of LTP appears to be phosphorylation of the transcription factor CREB (cAMP response element binding protein). CREB may be phosphorylated (either directly or indirectly) by the actions of a variety of kinases including CaMKIV (a nuclear version of CaMKII), the MAPK cascade and PKA (Lonze and Ginty, 2002).

The products of these genes, either mRNA or plasticity-related proteins must somehow be targeted back to the synapse where the L-LTP stimulus originated, although the mechanisms controlling this process are far from understood. Frey and Morris (1997) first proposed the so called 'synaptic tag' hypothesis. They used a weak LTP induction protocol capable of inducing E-LTP but not L-LTP, and a strong LTP induction protocol down a separate input that induced L-LTP. They then went on to demonstrate that the weak input could produce L-LTP if given shortly (less than 3 hours) before the strong input (Frey and Morris, 1997). They proposed that L-LTP inducing protocols caused a cell wide somatic signal that was somehow captured by synapses that had been 'tagged' by prior activity. CaMKII and PKA have both been implicated in this process (Barco *et al.* 2002; Redondo *et al.* 2010). Somewhat surprisingly, the molecular identities of the plasticity related proteins that mediate the increased synaptic efficacy are still largely undefined. As mentioned earlier the locus of the persistent expression is still the source of much debate, so perhaps it is unsurprising we know little about the mediators. PKM ζ (an atypical form of PKC, lacking any of its regulatory domains) has been contentiously implicated in the maintenance of increased AMPAR number. Expression of PKM ζ appears to require *de novo* protein synthesis (Hernandez *et al.* 2003). Addition of PKM ζ to the pipette solution results in an LTP-like mechanism involving the insertion of AMPARs, and a dominant negative form of PKM ζ blocks the synaptic induction of LTP (Ling *et al.* 2002). Perhaps most interestingly of all, PKM ζ inhibition may reverse previously induced LTP, suggesting that continued PKM ζ activity may be required for its persistence (Madroñal *et al.* 2010). However, contrasting reports come from studies in knockout mice lacking PKM ζ (Volk *et al.* 2013) and the specificity of PKM ζ inhibitors has been questioned (Wu-Zhang *et al.* 2012).

Evidence for a presynaptic locus

As already mentioned there is sufficient evidence for presynaptic adaptations occurring during NMDAR-LTP to warrant consideration. Zakharenko *et al.* (2001) first used the fluorescent dye FM1-43 to measure the rate of vesicle emptying before and after LTP induction. They found significant increases in loss of fluorescence, a measure of exocytosis (suggesting increased neurotransmitter release) after LTP induction using 200 Hz but not after LTP induction using 50 or 100 Hz. This dependence on stimulation protocol has been seen by other researchers (Bayazitov *et al.* 2007) using different fluorescence methods but again directly measuring vesicle fusion. Another approach has been to use the low affinity competitive NMDAR antagonist L-AP5 (Choi *et al.* 2000; Choi *et al.* 2003). The cooperative binding of glutamate to the NMDAR renders it insensitive possible changes in the kinetics of glutamate release. This means that an NMDAR-EPSC generated from a slow gradual release of glutamate from the presynaptic membrane could look very similar to a NMDAR-EPSC generated by a fast release of the same amount of glutamate - associated with a much higher peak concentration. Adding extracellular L-AP5 allows the antagonist to compete with glutamate for NMDAR occupancy and thus resolves differences in peak glutamate concentrations in the synaptic cleft. Before LTP induction at some synapses, the addition of L-AP5 caused a significant reduction in the NMDAR-mediated EPSC. This effect was abolished by prior induction of NMDAR-LTP (Choi *et al.* 2000). This result suggests that peak glutamate concentration in the synaptic cleft is raised, consistent with a modification in exocytosis from kiss and run to full fusion (Choi *et al.* 2003).

NMDAR-LTP: Summary

So far this section has only briefly reviewed some of the myriad of biochemical mechanisms implicated in NMDAR-LTP. No attempt has been made to comprehensively cover each topic or even address all of the current questions regarding models of NMDAR-LTP. NMDAR-LTP is just one kind of synaptic plasticity displayed within the CA3-CA1 synapse. In other synapses a whole different set of mechanisms may control changes in synaptic strength. Even within the hippocampus, at the dentate gyrus-CA3 synapse a completely different

NMDAR-independent mechanism of LTP is observed (Bortolotto *et al.* 2005). Hopefully this has given a flavour of the complexity underlying these changes in synaptic strength. For two very different proposed models of NMDAR-LTP (even using many of the same research papers as their supporting evidence) the reader is directed to Lüscher and Malenka (2012), and Lisman and Raghavachari (2006).

Modulation by subcortical afferents

The induction of NMDAR-LTP can be modulated by the actions of prior or coincident synaptic activity. An example of this has already been given in the form of mGluR modulation of NMDAR-LTP induction. The changes in the susceptibility of a synapse to undergo plasticity is referred to as metaplasticity. Specifically this section will deal with the modulation of NMDAR-LTP induction at the CA3-CA1 synapse by the major modulatory inputs to this area.

The largest modulatory input in CA1 is the cholinergic input from the medial septal nuclei. Leung *et al.* (2003) investigated the role of this cholinergic drive *in vivo* in both sleeping/immobile rats as well as in walking rats. As already discussed the hippocampal α -theta wave is driven by the cholinergic input from the septal nuclei during states of arousal. The authors found that induction of LTP was enhanced if induction during walking was performed compared to the LTP induced during the sleeping/immobile states. This effect was shown to be dependent on cholinergic activation (Leung *et al.* 2003). Gu and Yakel (2011) showed that small changes in the timing of the cholinergic input relative to the LTP-inducing stimulus resulted in widely varying effects ranging from LTP dependent on nicotinic receptors (cholinergic input stimulated 100ms prior to LTP induction) to LTP dependent on muscarinic receptors (cholinergic input stimulated 100ms after LTP induction).

The role of noradrenergic input into CA1 from the locus coeruleus is less clear, although numerous studies have found effects on LTP. Both the α and β subtypes have been implicated in lowering the threshold for synaptic induction of LTP (Katsuki *et al.* 1997; Izumi and Zorumski, 1999). A mechanism has been proposed where β -adrenergic activation results in phosphorylation of the GluR1 AMPAR subunit at residues S845 (a PKA site) and S831 (a CaMKII/PKC site) (Hu *et al.* 2007).

The role of the serotonergic input into CA1 has been much less studied compared to other inputs, but probably acts to inhibit LTP induction (Arias-Cavieres *et al.* 2010; West *et al.* 2009) although one study found that 5-HT₃ receptor antagonists facilitate LTP induction (Staubli and Xu, 1995). The inhibitory role for 5-HT is further supported by the finding that re-uptake inhibition by fluvoxamine also reduces LTP, possibly through actions on 5-HT_{1A} receptors (Kojima *et al.* 2003). The mechanism for these effects is largely unclear.

There has been considerable interest into the role of the dopaminergic input on LTP in the CA1 area and the mechanisms are fairly well defined. Frey *et al.* (1990) first demonstrated that dopaminergic antagonists could prevent the induction of L-LTP while leaving E-LTP unaffected. In support of this idea is the finding that D1 receptor knockout mice display a lack of L-LTP (Matthies *et al.* 1997). Also, facilitation of PKA activity (the major downstream target of D1 receptors) by phosphodiesterase inhibitors can convert E-LTP into L-LTP (Navakkode *et al.* 2004), and over activation of D1/D5 receptors can induce a protein synthesis dependent L-LTP-like process that occludes further L-LTP (Haung and Kandel, 1995). Together this provides strong evidence that dopamine D1 receptor activation is necessary for L-LTP (Stramiello and Wagner, 2008).

In summary, the above sections have described how NMDAR-LTP is a mechanism through which activity in pre- and post-synaptic neurones can cause changes in the efficacy of the connections between them. The intracellular complexity of this mechanism is bewildering, possibly suggesting an as yet unappreciated role in the integration and storage of information. Short term changes in synaptic strength can arise as a result of weaker inputs, whereas longer term changes require stronger inputs and protein synthesis. Phosphorylation of a variety of proteins by a variety of kinases control many of the steps in the mechanism. Modulation of NMDAR-LTP can result from subcortical activation of the relevant brain areas. Of particular relevance to this study is the control of L-LTP by dopaminergic innervation, presumably from the ventral tegmental area.

1.7.2 NMDAR-LTD/mGluR-LTD

NMDA receptors also play a role in the reduction of synaptic efficacy, termed long-term depression (LTD). LTD, when compared to its counterpart LTP, is relatively understudied. This may be in part due to the inconsistency often seen in the induction of LTD. In NMDA receptor-dependent LTD (NMDAR-LTD) the depression of synaptic strength is thought to be achieved mainly through the clathrin- and dynamin-dependent endocytosis of AMPA receptors (Lüscher and Malenka, 2012). One other major form of LTD can be observed at the CA3-CA1 synapse, mGluR-dependent LTD (mGluR-LTD). Again as for NMDAR-LTP there is evidence for both pre- and post-synaptic locations of expression (Ashby *et al.* 2004; Stanton *et al.* 2001). These mechanisms can be induced experimentally through slower frequency stimulation for longer periods compared to the experimental induction of NMDAR-LTP. NMDAR-LTD may still be dependent on depolarisation of the post-synaptic membrane and the influx of calcium through NMDA receptors though, although the differing magnitude and kinetics of the resultant calcium signal may determine whether LTP or LTD is triggered (Abraham *et al.* 2001). This may be due to the LTD phosphatase cascade having a higher sensitivity to calcium than the α CaMKII subunit. This would lead to selective activation of the phosphatase cascade at lower calcium concentrations than the kinase cascade associated with NMDAR-LTP. NMDAR-LTD is also thought to be inhibited during LTP induction by the PKA-dependent activation of an inhibitor of protein phosphatases (Blitzer *et al.* 1998). The processes underlying NMDAR-LTD are almost certainly as complex as those underlying NMDAR-LTP. Modification in the phosphorylation state of AMPAR subunits, control of lateral diffusion by disruption of the bond between AMPARs and their PSD anchoring proteins, and reductions in transmitter release have all been suggested. Interestingly, NMDAR-LTD may also involve the reduction of NMDAR-mediated current as well as the AMPAR-mediated current. The expected effect of this reduced NMDAR-mediated current would be to reduce the susceptibility of the synapse to undergo any further synaptic plasticity, a further example of metaplasticity. mGluR-LTP appears to work by a very different mechanism but ultimately resulting in the removal of AMPARs from the postsynaptic membrane and possibly other mechanisms such as changes in transmitter release (Lüscher and Huber, 2010).

One important distinction to make here is the difference between the reversal of LTP (known as depotentiation) and LTD. The fact that these two mechanisms are distinct suggests a role for LTD in the integration and storage of information. Depotentiation is the reversal of a previously induced LTP, and is generally only effective shortly after LTP induction *in vitro* (Fujii *et al.* 1991). This mechanism may represent the failure of a memory trace to consolidate into a long lasting change (forgetting). LTD on the other hand appears to be independent of LTP and therefore represents a possible alternative method of information storage (the formation of new memories).

As well as all the above mechanisms which are largely considered to be synapse-specific, neurones can also globally alter the sensitivity of all their synapses. This is generally thought to be a homeostatic response to long term changes in neuronal activity rather than any sort of information storage that the previous mechanisms are assumed to mediate. The mechanism may involve the insertion or removal of AMPA receptors as well as changes in transmitter release. A key feature of this sort of homeostatic response is that the relative differences in synaptic strength are maintained during these adaptations, suggesting perhaps that no loss of information has occurred. The idea that synaptic plasticity is the brain's method of information storage is a popular one, and the focus of the following section.

1.8 Synaptic plasticity and memory

One of the major assumptions of this and many thousands of other pieces of work published over the last half a century is that synaptic plasticity represents the encoding of experience to influence later behaviour (memory). As alluded to earlier many researchers believe that synaptic plasticity is a cellular correlate of memory. Perhaps far fewer researchers today would go as far as to say synaptic plasticity is both necessary *and sufficient* for memory. While the full debate surrounding the exact function of synaptic plasticity is beyond the scope of this work, this debate can briefly be put into context with regard to spatial memory and the hippocampus. Martin *et al.* (2000) defined a set of certain properties a proposed memory mechanism should have, these were; detectability, anterograde alteration, retrograde alteration and mimicry. Detectability infers that changes in synaptic

strength should be detectable following learning. Anterograde alteration suggests that augmenting or attenuating the changes in synaptic strength should enhance or inhibit learning and memory respectively. Retrograde alteration suggests that reversing the changes in synaptic strength should reverse the learning or memory and finally mimicry infers that memories should be able to be induced by the artificial induction of synaptic plasticity.

Detectability may be present in CA1 following associative learning tasks. The most convincing evidence for this comes from Whitlock *et al.* (2006). The authors demonstrated that high-frequency stimulation induced LTP was occluded in rats after learning an inhibitory avoidance task. They also found a spatially restricted increase in fEPSP slopes after learning, and increased phosphorylation of GluR1 S831.

Anterograde alteration of synaptic plasticity by inhibition of NMDARs seems to prevent learning. Intra-hippocampal infusions of D-AP5 (a competitive NMDAR antagonist) have been shown to prevent one trial learning in a spatial task (Bast *et al.* 2005). Significantly, D-AP5 did not affect memory retrieval in this model, whereas CNQX (an AMPAR/kainate antagonist) did. Interfering with the function of downstream signalling molecules can also disrupt LTP and spatial learning. Giese *et al.* (1998) introduced a point mutation into the CaMKII α subunit at threonine 286, the residue that undergoes autophosphorylation to prolong the action of CaMKII. LTP induction was disrupted, as was spatial learning in a water maze. As mentioned earlier anterograde alteration also predicts that enhancing LTP induction would enhance memory formation. Positive allosteric modulators of AMPARs can enhance LTP induction and enhance learning. Staubli *et al.* (1994a) demonstrated first that positive allosteric modulators could enhance LTP induction *in vivo* before going on to show that these compounds enhance learning in a spatial task (Staubli *et al.* 1994b).

Retrograde alteration of previously induced LTP is predicted to reverse any learning encoded by the plasticity affected. This was clearly demonstrated by the recent investigations into ZIP, a (possible) inhibitor of PKM ζ . The contentious role of PKM ζ has already been discussed, regardless of ZIPs specificity it does appear

to be able to reverse LTP and also abolish experience/hippocampus dependent behavioural plasticity (Serrano *et al.* 2008).

Mimicry is the last of the Martin *et al.* (2000) properties and by far the hardest to show clearly. Unfortunately demonstration of this property is critical to demonstrate synaptic plasticity is *sufficient* for memory storage, all other properties discussed so far merely show that plasticity is *necessary* for memory storage. There does not appear to have been any true demonstrations of mimicry for any type of memory in any brain region. Perhaps mimicry is just too technically challenging to show currently, or perhaps there is yet another layer of complexity to information storage in the brain.

1.9 Addictive substances evoke synaptic plasticity

Many molecules already implicated in synaptic plasticity have been shown to also be involved in animal models of drug addiction. As already discussed the NMDA receptor has been shown to play a critical role in perhaps the most common form of synaptic plasticity, and NMDA receptor antagonists can prevent the development of drug seeking behaviour in several animal models (Kalivas and Alesdatter, 1993; Harris *et al.* 2004; Harris and Ashton-Jones, 2003; Karler *et al.* 1989; Jeziorski *et al.* 1994; Kim *et al.* 1996; Tzschentke and Schmidt, 1995). By far the most studied locus for drug-evoked changes in synaptic transmission are the glutamatergic synapses on VTA dopamine neurones. However alterations at numerous other sites in nearly every brain region studied have been observed. The following discussion will just describe functional adaptations observed in VTA dopamine neurones as well as their major target sites; the nucleus accumbens, the prefrontal cortex, the hippocampus, and the amygdala.

1.9.1 The ventral tegmental area

As mentioned earlier exposure to most drugs of abuse as well as reward-related cues causes an increase in dopamine concentrations at VTA target sites (Schultz, 1998). This increase in dopamine release may be caused by a switch of VTA dopamine neurones from tonic to phasic firing (Schultz, 2007). In fact the induction of phasic firing in VTA dopamine neurones can be used to induce CPP (Tsai *et al.*

2009). Firing patterns of VTA dopamine neurones are thought to be controlled by glutamatergic inputs (White, 1996), and NMDAR-LTP at these synapses may be required for the formation of cue-reward associations (Stuber *et al.* 2008).

The first demonstration of drug-evoked changes in synaptic transmission was by Ungless *et al.* in 2001. The now widespread method of measuring synaptic 'strength' was developed in this paper and involved comparison of AMPAR-mediated currents with NMDAR-mediated currents to calculate an AMPA to NMDA ratio. Ungless *et al.* (2001) used this method to show that AMPA:NMDA was significantly increased for more than 5 but less than 10 days following a single non-contingent injection of cocaine. mEPSC frequency was also shown to be increased while mEPSC amplitude was unaffected, they therefore proposed that this increase was due to an increase in AMPA receptor number through a process dependent on NMDA receptor activation (NMDAR-LTP). A more recent study however (Mameli *et al.* 2011) suggests that along with this increase in AMPA, reductions in NMDA could also influence the measured increase in AMPA:NMDA. This increase in AMPA:NMDA has been shown for numerous addictive substances with diverse mechanisms of action such as morphine, nicotine and ethanol - although psychoactive drugs with minimal abuse potential such as fluoxetine and carbamazepine do not potentiate AMPA:NMDA (Saal *et al.* 2003). This increased AMPA:NMDA can persist for up to three months if the drug is self-administered (Chen *et al.* 2008) and can also be induced by cues previously associated with drug use (Stuber *et al.* 2008) and stress (Saal *et al.* 2003).

The mechanism for this increase in AMPA:NMDA in the VTA appears to be dependent on not only the activation of NMDA receptors (Ungless *et al.* 2001) but also the activation of D1/D5 receptors (Schilström *et al.* 2006) and possibly orexin receptors also located on VTA dopamine neurones (Borgland *et al.* 2006). The expression of increased AMPA:NMDA appears to be due to both an increase in the AMPAR-EPSC (Ungless *et al.* 2001) mediated by insertion of GluR2-lacking AMPA receptors (Bellone and Lüscher, 2006; Mameli *et al.* 2007), as well as a reduction in NMDAR (Mameli *et al.* 2011). This reduced NMDA-mediated current along with an increased AMPA-mediated current that contains calcium (due to the presence of GluR2 lacking AMPARs) can have complex effects on the subsequent further induction of synaptic plasticity. Mameli *et al.* (2011) found that LTP induction was

prevented in depolarised post-synaptic cells, whereas in hyperpolarised cells LTP induction was possible in *ex vivo* cocaine treated slices (an example of anti-Hebbian synaptic plasticity). The reversal of this increased AMPA:NMDA seen after 10 days in animals injected with a single dose of drug may be mediated by a metabotropic glutamate receptor dependent process of depotentiation, as disruption of mGluR1 signalling can prolong the increased AMPA:NMDA (Mameli *et al.* 2009). In fact, activation of mGluR1 directly can reverse this increase in AMPA:NMDA by the replacement of GluR2-lacking receptors with GluR2 containing ones (Bellone and Lüscher, 2005; Bellone and Lüscher, 2006).

Given the central role often given to NMDAR-LTP in VTA dopamine neurones during reward-related learning it is surprising that NR1 knock-out mice that lack NMDAR-LTP in dopamine neurones still show behavioural sensitisation and CPP (Engblom *et al.* 2008, although see Harris *et al.* 2004 for a conflicting report). This data, along with other knock-out models has led to the suggestion that strengthening of VTA synapses may not contribute to long or short term behavioural modifications, but be responsible for the initiation of long-term neuroadaptations that control the persistence of drug seeking behaviour (Van de Oever *et al.* 2012). The origins of the glutamatergic innervation in to the VTA that is potentiated in response to addictive substances remains to be identified and warrants further investigation.

A much less understood adaptation within the VTA also occurs at inhibitory GABAergic synapses. Morphine has been shown to prevent the induction of LTP in GABAergic synapses (Nugent *et al.* 2007) with similar effects seen after administration of nicotine or cocaine (Niehaus *et al.* 2010) and ethanol (Guan and Ye, 2010). Down regulation of GABA_A receptors has also been observed following chronic administration of cocaine (Liu *et al.* 2005). The role of VTA GABA is much less understood, with the VTA receiving GABAergic projections from nucleus accumbens as well as the rostromedial tegmental nucleus; GABAergic interneurones may also be affected. Currently the behavioural consequences of these adaptations in GABAergic transmission are unclear.

1.9.2 *The nucleus accumbens*

The nucleus accumbens is the major target of VTA dopamine neurones as well as receiving numerous glutamatergic projections from other mesocorticolimbic system components such as the prefrontal cortex, hippocampus, and amygdala.

In the nucleus accumbens the effects of addictive substances are much more complex, likely in part due to the fact that the nucleus accumbens is really a set of functionally distinct neurones occupying the same physical space. Non-contingent administration of cocaine for 5 days was sufficient to reduce *ex vivo* measurements of AMPA:NMDA (ie. LTD). During abstinence the AMPA:NMDA then increases (Kourrich *et al.* 2007) and is reduced following a challenge dose (Thomas *et al.* 2001). This pattern of reduction of AMPA-mediated transmission gradually turning into potentiation is supported by biochemical expression studies (Boudreau *et al.* 2007). Prolonged self-administration of cocaine has also been shown to reduce excitatory transmission in the nucleus accumbens shell (Schramm-Sapota *et al.* 2006) with a concurrent reduction in experimentally-induced LTD (Martin *et al.* 2006). This reduction in experimentally induced LTD was observed only in animals self-administering cocaine, not those receiving cocaine in a yoked manner or self-administering food. This suggests that unique synaptic adaptations may be correlated with drug experience-dependent behavioural adaptations (Martin *et al.* 2006). As in the VTA, evidence for changes in the stoichiometry of AMPA receptors also exists, although interestingly this change (insertion of GluR2 lacking receptors) may only occur after prolonged withdrawal (Conrad *et al.* 2008), a period known to be associated with increased drug seeking behaviours (Grimm *et al.* 2001). The precise regulation of AMPAR expression in the nucleus accumbens following exposure to addictive substances is yet to be elucidated, however there is mounting evidence in support of a role for extracellular-signal regulated kinase (ERK). Phosphorylation of ERK during LTP can increase the insertion of AMPARs (Zou *et al.* 2002); and ERK phosphorylation is increased following withdrawal, something that is reversed following a challenge dose (Boudreau *et al.* 2007). In further support of a vital role of ERK phosphorylation in drug seeking behaviour is the observation that ERK phosphorylation inhibition prevents the expression of CPP (Gerdjikov *et al.* 2004; Miller and Marshall 2005).

As alluded to earlier, significant differences exist between changes induced by non-contingent administration and self-administration. In fact differences exist between animals self-administering cocaine. Experimentally-induced LTD is attenuated following withdrawal from self-administration (Martin *et al.* 2006) and both LTD and LTP are impaired during protracted withdrawal (Martin *et al.* 2006; Moussawi *et al.* 2009). Kasanetz *et al.* (2010) found that this impaired LTD only occurs in animals showing behavioural signs of compulsive drug use, whereas in animals that maintained a steady rate of drug intake this effect was absent. Changes in stoichiometry may also be dependent on the route of administration, Lu *et al.* (2003) found increases in the expression of GluR1 and GluR2 following non-contingent administration of cocaine. Self-administering animals only show increases in the expression of GluR1 following withdrawal (Conrad *et al.* 2008; Lu *et al.* 2003). In the nucleus accumbens core (a sub-region of the nucleus accumbens) there is evidence that extracellular glutamate levels may be reduced following both non-contingent and contingent administration (Baker *et al.* 2003; Miguens *et al.* 2008). This reduced extracellular glutamate can increase release probability through reduced activation of mGluRs (Moran *et al.* 2005; Moussawi *et al.* 2011) and may be responsible for the reduced LTP/LTD seen after withdrawal (Moussawi *et al.* 2009).

Interestingly, there is evidence that a sub-population (2-3%) of MSNs in the nucleus accumbens may be differentially affected after withdrawal from chronic cocaine administration. Using a fluorescent form of c-fos (a neuronal activity marker) Koya *et al.* (2012) showed that whilst the majority of neurones recorded from showed an increase in AMPA:NMDA, selectively recording from strongly activated neurones revealed a decreased AMPA:NMDA; most likely due to the formation of new synapses containing only NMDA receptors (so called 'silent' synapses). These strongly activated neurones may be both necessary and sufficient for certain drug-induced behaviours (Koya *et al.* 2009). The identification of this sub population of neurones mediating certain drug-induced behaviours supports the 'currant bun' hypothesis of memory storage in the brain.

1.9.3 The medial prefrontal cortex

Evidence for changes in mPFC synaptic transmission is much less substantial than other brain regions, which is surprising given its often stated important role in the development of addictive behaviours. The mPFC receives a significant dopaminergic innervation from the VTA that is involved in the acquisition of self-administration (Schenk *et al.* 1991; Weissenborn *et al.* 1997). The glutamatergic projection from the mPFC to the nucleus accumbens appears to be necessary for the reinstatement of drug-seeking behaviours (Kalivas *et al.* 2005; LaLumiere and Kalivas, 2008). There is evidence however, that cue-induced reinstatement of heroin seeking may cause a decrease in AMPA:NMDA through the internalisation of AMPA receptors (Van de Oever *et al.* 2008). This decrease in excitatory transmission may be further enhanced by an increase in GABA activity (Van de Oever *et al.* 2010). Therefore cue-induced relapse may be dependent on an acute decrease in mPFC control of nucleus accumbens activity. There is also evidence of increased NMDA receptor expression following protracted cocaine withdrawal (Ben-Shahar *et al.* 2009), and a facilitation of stimulus-induced LTP in acute cocaine withdrawal possibly due to reductions in GABA transmission (Lu *et al.* 2010). Much further work is needed on this brain region if its role in drug seeking behaviour is to be better understood.

1.9.4 The amygdala

The amygdala complex is a group of structures with distinct connectivity and functions, of particular interest to addiction are the basolateral amygdala (BLA) and the central nucleus of the amygdala (CeA). The basolateral amygdala is heavily implicated in the formation of drug-cue associations and is also involved in cue-induced and stress-induced relapse (Buffalari and See, 2010; Fuchs and See, 2002; Gabriele and See, 2010; Kruzich *et al.* 2001; McLaughlin and See, 2003). The CeA is thought to mediate the expression of drug seeking behaviours (Buffalari and See, 2010; Kruzich and See, 2001; Lu *et al.* 2005). Despite this wealth of evidence implicating the amygdala in drug seeking behaviour very few studies have been published on the functional changes occurring in response to addictive substances. Non-contingent administration of cocaine reduces stimulus-induced LTP (Goussakov *et al.* 2006), an effect that may be longer lasting after

self-administration (Lu *et al.* 2005b). The BLA to CeA projection expresses enhanced CRF-induced LTP (CRF is a stress hormone) after prolonged withdrawal from non-contingent cocaine (Fu *et al.* 2007, Pollandt *et al.* 2006). CRF antagonism can also prevent stress induced relapse (Shaham *et al.* 1998).

1.9.5 The hippocampus

The functional effects of addictive substances in the hippocampus is another relatively neglected area, although recently there seems to have been a growing interest in the role the hippocampus plays in drug seeking behaviour. The hippocampus is functionally connected to the VTA through a variety of indirect pathways and also receives a direct dopaminergic input from the VTA (Gasbarri *et al.* 1994; Gasbarri *et al.* 1997). There is mounting evidence that this dopaminergic projection may play a vital role in controlling hippocampal synaptic plasticity. The ventral CA1 expresses dopamine D1/D5 receptors that couple to the activation of PKA. PKA has been shown to be required for the persistence of LTP in the hippocampus (Duffy and Nguyen, 2003). Dopamine release in the hippocampus appears to be responsible for the facilitation of experimentally-induced LTP induced by a novel environment in awake rats (Li *et al.* 2003). It follows then that if activation of the VTA by the pharmacological actions of an addictive substance was paired with a hippocampal dependent learning task, then this learning may be enhanced. Indeed rats that self-administer cocaine showed increased experimentally-induced LTP, and perform better in an unrelated Morris water maze task (Del Olmo *et al.* 2007), and D1/D5 receptor antagonism in the hippocampus can reduce place preference to morphine (Rezayof *et al.* 2003).

Most studies investigating the hippocampus have employed fEPSP recordings; as this area with its ordered topography is particularly suited to this technique. In contrast to many of the studies investigating other brain regions mentioned above, morphine is often used instead of cocaine as the test drug. There is at present conflict regarding the effects of non-contingent morphine on hippocampal transmission. This may largely be due to the effects of tolerance and withdrawal, processes that are particularly relevant with respect to morphine. Another reason for this lack of clarity may be the over-use of fEPSP recordings in the absence of more powerful techniques such as whole cell patch clamp. fEPSP recordings often

yield inconclusive results and so without concurrent patch clamp techniques data are often left open to different interpretations.

Most researchers find that there is a reduction in stimulus-induced LTP after non-contingently administered morphine (Xia *et al.* 2011; Pu *et al.* 2002; Lu *et al.* 2010; Bao *et al.* 2007), although there are conflicting reports (Billa *et al.* 2010, Salmandazeh *et al.* 2003; Mansouri *et al.* 1999). A reduction in stimulus-induced LTP is indicative of either prior LTP occurring *in vivo* (indicating the drug augments LTP) or could be due to a reduction in metaplasticity (indicating that the drug attenuates LTP). To date only one lab appears to be investigating this dichotomy using higher resolution methods such as whole cell patch clamp. Billa *et al.* (2010a) found that AMPA:NMDA was increased following morphine treatment and that the AMPAR-mediated current had become inwardly rectifying. Using biochemical data to support their argument they concluded that prior LTP had occurred *in vivo*. They did not observe any change in stimulus-induced LTP however and so the mechanism underlying this reduction in LTP is still not clear. To add to the confusion the use of repeated injections of high doses of morphine during their study means that it is very difficult to separate the effects of prior morphine experience with the effects of withdrawal. Using cocaine as a test substance, Guan *et al.* (2009) found that chronic cocaine appeared to have no effect on stimulus-induced LTP but that withdrawal enhanced LTP by a corticotrophin-releasing factor-dependent mechanism. This supports the Billa *et al.* (2010a) observation that morphine administration may not affect LTP induction, although using the same paradigm as Billa *et al.* (2010a), Xia *et al.* (2011) found that LTP induction was impaired if morphine was administered in a novel context.

Current literature is therefore inconclusive regarding the effects of addictive substances in the hippocampus, although it is clear that information processing in this region is affected. Given the relatively numerous papers published on the effects of addictive substances in the hippocampus it is surprising that there still exists such uncertainties surrounding even the most simple questions. These apparent contradictions between papers likely stem from the mixed effects of withdrawal, contextual drug-related learning, and the pharmacological actions of the drug. In order for our understanding to further progress it is necessary to isolate these effects so that adaptations correlated to addictive behaviors can be

identified. Also, as was seen in the nucleus accumbens (Koya *et al.* 2012) behaviors may be dependent on sub sets of neurones and these neurones may express differing responses to drug-associated learning. In order to address these issues two changes are needed to experimental design. The injection paradigms used for morphine need to be more carefully designed to control for the effects of tolerance and withdrawal, and higher resolution techniques need to be routinely employed.

1.10 Actions of morphine in CA1.

Morphine is an opiate that can be isolated as the main active ingredient of *papaver somniferum*. It acts on a class of GPCRs known as opioid receptors. There are three major types of opioid receptor, given the Greek letters μ , δ , and κ . Morphine has higher affinity and efficacy at the μ -subtype and the reinforcing actions of morphine in the VTA are thought to be dependent on μ receptors (Contarino *et al.* 2002). μ receptors are expressed on the soma and presynaptic nerve terminals of GABAergic interneurons of the VTA. Activation of somatic μ receptors by morphine can hyperpolarise GABA neurones through actions on G-protein activated inwardly rectifying potassium channels (GIRKs), whereas the major effect at nerve terminals is thought to be inhibition of voltage-gated calcium channels and/or direct inhibition of the SNARE pathway (Yoon *et al.* 2007). This disinhibition of VTA dopamine neurones can increase the extracellular concentration of dopamine in all VTA target regions including the ventral portion of CA1.

In the CA1 region of the hippocampus μ receptors are also expressed on the GABAergic interneurons and are known to decrease their rate of firing (presumably through activation of GIRK channels). Similar to the effect in the VTA, disinhibition of pyramidal cells is also observed (Pang and Rose, 1989). The effects of morphine in CA1 could therefore be the combined effect of increased dopamine and disinhibition of pyramidal neurones. Therefore the actions on hippocampal processing will undoubtedly be complex. One example of this complexity is the effect on the integration of inputs from CA3 and the entorhinal cortex. Prior activation of the perforant path from the entorhinal cortex can inhibit the EPSP induced by Schaffer collateral stimulation in a temporally restricted manner. This is thought to be due to GABA_B activity (Dvorak-Carbone and

Schuman, 1999). Morphine administration can prevent this inhibition of CA3 input by the entorhinal cortex (McQuiston, 2011). The expected effect of this mechanism would be positive summation of those inputs that would normally counteract one another. Combined with the increased dopamine due to disinhibition of the VTA this could lead to plasticity and association of those normally contrary inputs. Morphine will also undoubtedly have other indirect effects on hippocampal function (above is just one example) due to its effects on other brain regions with either direct or indirect projections to CA1 such as the GABAergic projection from the septal nuclei.

1.11 Hippocampal synaptic plasticity as a possible therapeutic target for the treatment of drug addiction

As already discussed the hippocampus is a brain structure thought to be intimately involved in the processing of information regarding environments surrounding the animal (the context) and possibly many other mnemonic functions. The presentation of a drug-paired context has been shown to result in behavioural changes in response to the context, as well as gating the influence of discrete cue-drug associations. These behavioural changes are dependent on the normal physiological functions of the hippocampus. Synaptic plasticity in the hippocampus (and many other regions) occurs in response to addictive substances and therefore the prevention or reversal of synaptic plasticity may prevent drug seeking behaviours.

A possible therapeutic mechanism comes from studies concerning the 'reconsolidation' of memories. In psychology, memories once formed undergo a consolidation process to convert from short-term to long-term memories. This consolidation process has startling similarities to early and late forms of LTP. Protein synthesis inhibition disrupts L-LTP and long-term memory while leaving E-LTP and short-term memory intact. Protein synthesis inhibition only appears to be effective during a short period following learning so would be unsuitable for targeting long held memories such as those presumably present in drug addicts. Reactivation of these memories however may render them again susceptible to disruption (Morris *et al.* 2006).

Milekic *et al.* (2006) first trained rats to express CPP for morphine using similar methods to those described in the Methods section below. They then showed that 1 week after CPP had been expressed in these rats, CPP could be persistently disrupted, or reversed, by injections of protein synthesis inhibitors. The success of this treatment depended on a conditioning trial (involving both the injection of the drug and exposure to the drug-paired context) immediately preceding protein synthesis inhibition. This effect was not seen if the animals were re-exposed to the drug-paired context or drug alone, and was dependent on protein synthesis inhibition in the amygdala, hippocampus and nucleus accumbens but not the VTA. This effect seemed very persistent, as it was both long lasting (more than 4 weeks) and resistant to drug-primed reinstatement (Milekic *et al.* 2006). These results have been replicated by numerous authors using a wide variety of inhibitors of NMDAR-LTP, for an up to date and comprehensive review on this field see Sorg (2012). The major advantage of this approach is that it would presumably be specific for the reactivated memory. Reactivation of such memories in humans however may be more problematic than in rodents, as the failure of exposure therapy demonstrated (previously discussed, Marissen *et al.* 2007). Whatever the potential these therapies hold in human addicts, these studies lend further support to idea that synaptic plasticity processes within the hippocampus are critical in initiating at least some forms of drug seeking behaviour.

One other obvious method of retrograde alteration of drug related LTP in the hippocampus would be the disputed inhibitor of PKM ζ , ZIP. There do not appear to be any studies specifically aimed at the effects of ZIP in the hippocampus following CPP or any other drug related learning task however. One of the obvious disadvantages of using ZIP compared to the disruption of reconsolidation would be that ZIPs action would be non-specific throughout the locus of injection and so potentially could have wide ranging effects on memory stored in that area.

Further work is needed to identify specific functional changes in the hippocampus that are correlated with the formation of drug seeking behaviours and relapse. The identification of such changes should hopefully lead to novel approaches to treatment, or the development of more specific drugs to retroactively target these changes.

1.12 Rationale for Experimental Design

In this Introduction, the idea that drug addiction arises from a substance's ability to usurp the brain's mechanism for learning and memory has been introduced. One of the greatest unmet needs in the treatment of drug addiction is the prevention of relapse. This process is fundamentally dependent on the brain's identification of drug-predictive cues through associative learning processes. The hippocampus has been shown to be intimately involved in these processes. Particularly involved in spatial and contextual processing in rodents, the hippocampus also plays a more general role in other higher forms of memory and cognition (at least in humans, but probably in rodents too). The reason for this apparent divide could be as simple as the lack of appropriate models to study these forms of memory in rodents.

Previous studies have demonstrated functional changes in hippocampal synaptic transmission after the administration of non-contingent morphine (eg. Billa *et al.* 2010) however it is unclear what these changes mean on a functional level. It is possible that these changes simply occur as a result of the pharmacological action of morphine, or morphine withdrawal, and do not encode any specific information. In order to elucidate fully the role of hippocampal synaptic plasticity in encoding associative addiction-related memories, it is essential to study such changes following contingent administration of drugs of abuse. Therefore the aim of this study was to determine the nature of synaptic changes occurring as a result of the formation of context-drug associations. In order to do this, comparisons were made between the effects of morphine when administered contingently on presentation of a particular environment, or non-contingently. The aim of this paradigm was to induce behavioural adaptations of relevance to addiction that were dependent on associative learning processes.

The conditioned place preference model was chosen as it was ideally suited to this aim. Relatively young mice could be trained to exhibit CPP, reducing the technical problems associated with whole cell patch clamp recordings in older mice. Another requirement of the model was that it should use the minimum dose possible to induce CPP, as the effects of withdrawal/dependence could mask any potentially

important changes. The CPP model again was suitable for inducing behavioural plasticity with relatively low doses of drug.

A combination of fEPSP recordings and whole cell patch clamp was used. fEPSP experiments, while useful for studying the function of populations of neurones under more physiological conditions and technically easier provide less definitive results and so these were performed first. Whole cell patch clamp became necessary in order to further investigate the observed effects in fEPSP experiments.

1.13 Aims of the project

To induce addiction relevant behaviours in mice that are dependent on associative learning processes. This was achieved by demonstrating CPP to morphine.

To identify the modifications in synaptic transmission that occur specifically in response to the induction of these behavioural changes. This was achieved by using a range of electrophysiological studies in *ex vivo* brain slices, taken from animals that underwent CPP training.

Chapter 2: Methods

2.1 Introduction

This project utilised a combination of *in vivo* behavioural experiments and *ex vivo* electrophysiological experiments. The behavioural methods are described first, and then the electrophysiological methods. The contents of all the solutions used can be found in a section 2.5.

2.2 Behavioural methods

2.2.1 Animals used

Male C57BL/6J mice were weaned at P21 and separated into cages containing 4 animals per cage. The cages were then moved to a holding room adjacent to the room where behavioural experiments were to be performed. Mice were maintained on a 12 hour light/dark cycle (lights on at 6am) and were allowed access to food and water *ad libitum*.

2.2.2 Handling/identification

Mice were identified by means of an ear clip that was performed at the time of weaning. After being allowed to become accustomed to the holding room for between one and three days, the animals were handled twice per day (separate sessions approximately 30mins apart). Handling consisted of repeatedly picking the mouse up, stroking and 'scruffing' the mouse. This handling was performed on consecutive days for between 2 and 7 days, by the end of this period mice showed no visible signs of distress upon being handled. The day following the last day of handling the mice entered the behavioural experiment (see following section).

2.2.3 Experimental protocol: conditioned place preference (biased)

The apparatus was a three-chambered box, consisting of two 15cm x 30cm chambers (one with white walls, the other with black walls) separated by a middle compartment (15cm x 15cm) with yellow walls. The room containing the apparatus was illuminated using red light so as to reduce the natural aversion the mice may have had to the white chamber. Both the black and yellow chambers had a smooth

plastic floors whereas the white chamber had a stainless steel mesh floor. Each of the chambers was connected by small (4cm x 6cm) openings that were blocked during conditioning trials. All experiments were performed during the lights off period when the mice were expected to be most active.

Day 1: Pre-test. Mice were placed into the middle (yellow) chamber of the apparatus with free access to all three compartments. The animals' movements were recorded using an overhead camera for 15 minutes. Using this environmental configuration ensured that there was a significant inherent preference for the black walled (saline-paired) chamber during the day 1 pre-test. These experiments were performed in parallel so while each mouse had its own CPP apparatus, all mice from a particular cage (four mice per cage) were being tested in the same room at the same time.

Day 2+3: Handling. Mice were handled twice per day for approximately 5 minutes during which the mice would be repeatedly picked up and 'scruffed'.

Day 4-7: Conditioning. Mice were injected once per day with either saline or alternate injections of saline (10ml kg⁻¹ i.p.) and morphine (10ml kg⁻¹, 10mg kg⁻¹ i.p.) (the first injection day was always saline) before being confined to their assigned compartments for 30 minutes. During this time the subjects had no access to the small middle compartment. Each animal received either 4 saline injections over 4 days (SAL CPP) or 2 saline and 2 morphine injections over 4 days (MOR CPP). It is worth emphasising that SAL CPP group had two injections of saline in the normally morphine paired black side of the apparatus (a kind of sham morphine injection).

Day 8: Test. Mice were placed into the middle compartment with free access to both sides. The subjects' movements were recorded by an overhead camera for 15 minutes. Following the test phase animals were replaced in their home cage (for between 15mins and 4 days) before being taken in an insulated container to be anaesthetised prior to decapitation for the purpose of making brain slices.

2.2.4 Experimental protocol: conditioned place preference (unbiased)

The method used for CPP induction was changed between making the fEPSP recordings (Chapter 3) and the whole-cell patch clamp recordings (Chapter 4). This was due to methodological issues discussed in further detail in the Appendix.

The apparatus was a two-chambered box consisting of two equally sized 15cm x 16cm chambers separated by a removable guillotine door (Ugo Basile, catalogue number 42503). One chamber had plain black walls, the other had stripy black and white walls and were further distinguished by different floor textures. Each conditioning apparatus was contained in a separate sound attenuation box (MED Associates, UK). Drug-paired chambers were pseudo-randomly selected but counterbalanced so an equal number of subjects were conditioned to each chamber. All experiments were performed during the lights off period when the mice were expected to be most active.

Day 1: Pre-test. Mice were placed into a pseudo random side of the apparatus with free access to both compartments. The animals movements were recorded using an overhead camera for 30 minutes. Again, four experiments were run in parallel but this time the start date of each experiment was staggered (See Figure 2.1).

Day 2+3: Handling. Mice were handled twice per day for approximately 5 minutes during which the mice would be repeatedly picked up and 'scruffed'.

Day 4-7: Conditioning. Mice were injected once per day with either saline or alternate injections of saline and morphine (just as in the previous CPP experiment. 10mg kg⁻¹ i.p.) (the first injection day was always saline) before being confined to their assigned compartments for 30 minutes. Each animal received either 4 saline injections over 4 days (SAL CPP) or 2 saline and 2 morphine injections over 4 days (MOR CPP).

Day 8: Test. Mice were placed into a pseudo-random side of the apparatus with free access to both sides, the animals' movements were recorded by an overhead

camera for 30 minutes. Immediately following the test phase animals were placed in insulated container and taken to be anaesthetised prior to decapitation for the purpose of making brain slices.

2.2.5 Experimental protocol: non-contingent administrations

Non-contingent groups (both saline and morphine) had exactly the same handling and pre-experimental experiences as those animals undergoing conditioned place preference. Instead of the pre-test session (day 1) each subject was briefly picked up and replaced in the home cage. All animals received 4 daily injections (days 4-7: either 4 saline or 2 saline + 2 morphine) but were placed directly into the home cage immediately following injections. On the final day (day 8) mice were placed directly into the insulated container for transport to the electrophysiology laboratory.

2.2.6 Drugs used

All morphine was purchased from MacFarlan Smith (Edinburgh, UK) and kept frozen in solution until immediately before use when it was thoroughly defrosted at room temperature. The morphine solution contained 1mg ml^{-1} morphine sulphate in 0.9% saline. All injections were given intraperitoneally at a dose volume of 10ml kg^{-1} , giving a final dose of 10mg kg^{-1} (unless otherwise stated).

0.9% Saline solution was purchased from national vet supplies Dechra (UK) and stored at 5°C in sealed vials that were opened immediately before use. All injections were given intraperitoneally at a dose volume of 10ml kg^{-1} .

The movement of all animals was recorded using a video camera connected directly to a PC and analysed in real time using Noldus XT[®] software. The time spent in each zone, total distance travelled, and number of entries in to each zone was recorded.

DAY	0	1	2	3	4	5	6	7	8	9	10	11
MOUSE 1 MOR CPP		PRE- TEST			Sal	Mor	Sal	Mor	TEST			
MOUSE 2 SAL CPP			PRE- TEST			Sal	Sal	Sal	Sal	TEST		
MOUSE 3 MOR CPP				PRE- TEST			Sal	Mor	Sal	Mor	TEST	
MOUSE 4 SAL CPP					PRE- TEST			Sal	Sal	Sal	Sal	TEST

Figure 2.1 A table showing the handling and treatment performed on a cage of four mice undergoing conditioned place preference.

Each column represents a day, each row a separate mouse in the same cage. Blue areas represent handling days , green areas represent test days and red areas represent conditioning days(Sal and Mor represent saline and morphine injections respectively).

2.3 *Electrophysiology methods*

2.3.1 *Brain slice preparation*

Mice were first anaesthetised using a solution of 160mg kg⁻¹ ketamine and 20mg kg⁻¹ xylazine and once under general anaesthesia were decapitated. The brain was immediately removed and placed in ice-cold cutting solution saturated with 95% oxygen/5% carbon dioxide. Transverse brain slices containing the ventral hippocampus were cut at a setting of 275 or 350µm using a DTK-1000 vibratome (DSK). The cut slices were placed into an incubating chamber containing ACSF saturated with 95% oxygen/5% carbon dioxide at 30°C and allowed to slowly cool to room temperature for 30min before being warmed back up to 31°C for a further 30min. In all electrophysiology experiments, no more than one cell per slice was recorded from. No more than two cells per animal was recorded from.

2.3.2 *Extracellular field recordings*

Brain slices cut at a setting of 350µm were transferred to a recording chamber where they were held at the interface of humidified 95% oxygen/5% carbon dioxide and aCSF saturated with 95% oxygen/5% carbon dioxide (continuously perfused at a flow rate of 1.5 – 2 ml min⁻¹) at a temperature of 35°C. The position of the slice at the interface meant that the lower half of the slice was submerged in the aCSF with the upper surface exposed to humidified 95% oxygen/5% carbon dioxide.

The hippocampus was identified by the morphology of the dentate gyrus and Ammon's horn and the CA1 area as the region furthest away from the dentate gyrus along the cell body layer. A teflon coated bipolar stimulating electrode (tip separation 150µm) was placed in the stratum radiatum on the CA3 side of the recording electrode. The recording electrode consisted of a pulled glass pipette with an electrical resistance of 3-6 MΩ and was filled with aCSF. The recording electrode was then placed on the stratum radiatum side of the CA1 pyramidal cell body layer (see Figure 2.2, next page).

The stimulation consisted of a square wave of 100 μ s duration at a frequency of 0.05Hz and continued for the duration of the experiment. Stimuli were generated either using a MASTER-8 (A.M.P.I.) pulse generator or were computer-generated with WinEDR software (University of Strathclyde) via a constant-current stimulation isolation unit (DS2A, Digitimer).

Evoked field EPSPs (fEPSPs) were amplified using an Axoclamp-2A amplifier (Axon Instruments), run through a 1 kHz low pass filter (NL 106, Digitimer) and 50Hz noise eliminator (Hum Bug, Quest Scientific) before being digitized at a sampling rate of 10 kHz (CED Micro 1401 analogue-digital converter). All analysis was by WinEDR or WinWCP software (University of Strathclyde). The slope of the fEPSP was calculated by fitting a straight line between 20% and 80% of the maximum amplitude. A stimulation intensity that gave 50% of the maximum slope was first found and then this chosen stimulation intensity was unchanged for the remainder of the recording session.

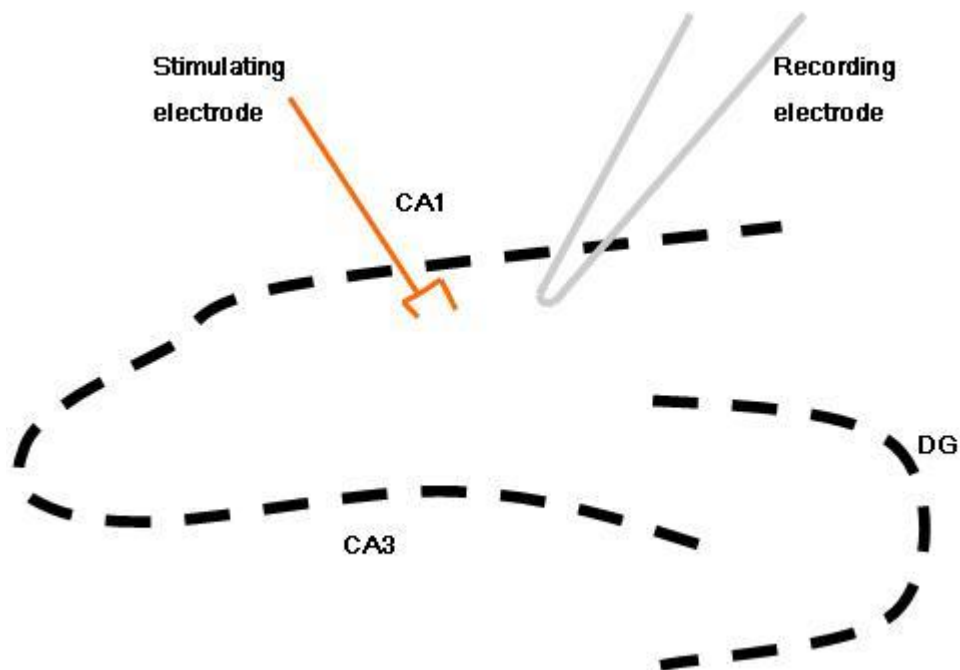

Figure 2.2 A schematic representation of the hippocampus showing the approximate location of the recording and stimulating electrodes during fEPSP recordings.

Dashed line represents the cell bodies of the pyramidal cell layer. DG - dentate gyrus.

To induce stimulus-induced long-term potentiation (LTP), theta burst stimulation was applied. This consisted of 4 bursts with a 15 second inter-burst interval. Each burst (see Figure 2.3) consisted of 10 trains of 5 pulses at 100Hz with an inter-train interval of 0.25 seconds. To induce stimulus-induced long-term depression (LTD), low frequency stimulation (LFS) was applied. This consisted of single pulses delivered at 2 Hz for 10 minutes (a total of 1200 pulses). To measure paired-pulse facilitation, twin pulses (50ms inter-pulse interval) were delivered at 0.1Hz.



Figure 2.3 A schematic representation of the theta burst protocol.

Time is represented by the x-axis and vertical lines represent single square wave stimulations of 100 μ s duration. This diagram represents one of the four bursts used to induce LTP during the fEPSP recordings.

fEPSPs were recorded for at least 20 minutes or until a stable baseline was recorded, prior to theta-burst or LFS stimulation. 6 consecutive fEPSP responses were averaged and the slope of fEPSPs measured. Data are presented as percentage of baseline, taking the final 5 measurements of pre-theta-burst or pre-LFS stimulation as baseline responses. For paired-pulse data analysis, 10 consecutive paired-pulse fEPSPs were recorded and averaged, the paired-pulse ratio was measured as the slope of the second fEPSP response as a function of the slope of the first fEPSP. A maximum of one recording per slice was taken. A maximum of two recordings per animal were performed.

2.3.3 Whole-cell patch clamp electrophysiology

A brain slice (cut at a setting of 275 μ m) was transferred to an Olympus BX51WI upright microscope and cells visualised using oblique optics. The recording chamber in the microscope was continuously perfused with ACSF saturated with

95% oxygen/5% carbon dioxide at a flow rate of 3ml min⁻¹. The slice was submerged completely in ACSF at 31°C.

The hippocampus was identified by the morphology of the dentate gyrus and Ammon's horn and the CA1 area as the region furthest away from the dentate gyrus along the cell body layer. Pyramidal cells were identified by their general cell morphology and their presence within the cell body layer of the CA1.

For evoked responses, a Teflon coated bipolar stimulating electrode (tip separation 150µm) was placed in the stratum radiatum on the CA3 side of the recording electrode. The stimulation consisted of a square wave of 150µs duration at a frequency of 0.1Hz. Stimuli were generated using WinEDR software via a constant-current stimulation isolation unit (DS2A, Digitimer). For paired-pulse recordings, twin pulses (inter-pulse interval: 50 ms) were applied.

The recording electrode consisted of a pulled glass pipette with an electrical resistance of 3-4 MΩ and filled with intracellular solution A or B. Evoked EPSCs were recorded using intracellular solution A, which contained fluoride ions to block GABA_A receptors (Kay, 1992). Miniature EPSCs (mEPSCs) and miniature IPSCs (mIPSCs) were recorded using intracellular solution B, and 1 µM tetrodotoxin (Ascent Scientific) was continually present in the ACSF. To record mEPSCs, cells were voltage-clamped at -70mV (approximate Cl⁻ reversal potential) To record mIPSCs, cells were voltage-clamped at 0mV (approximate reversal potential of AMPARs).

Some cell somata were cleaned using a flow of ACSF from a broken pipette prior to attachment. Cells were voltage-clamped (apart from when stated, holding potential was -70mV). Data were amplified and filtered at 2 kHz (Axopatch 200A amplifier, Axon Instruments), passed through a 50Hz noise eliminator (Hum Bug, Quest Scientific) before being digitized at a sampling rate of 10 kHz (Digidata 1440 A analogue/digital converter, Axon Instruments). All data were saved to computer using WinEDR software. The liquid junction potentials (~10mV) were calculated using Axon™ pCLAMP® software and compensated for during the experiments.

At the start of each recording, a measurement of series resistance was made following a 5mV, 50 ms voltage step. Whole-cell capacitance was also measured using the same 5mV, 50 ms voltage step generated by the Axopatch 200A amplifier. The whole cell capacitance and series resistance transients were compensated for manually using the controls on the amplifier. Any cell that showed a change in series resistance during the course of the recording of more than 25% was excluded from analysis. A stimulus-response curve was then generated to find the maximum response, and a stimulation value (constant current) that gave a response equal to ~75% of the maximum was used for the duration of the experiments. Any cell that had a maximum EPSC amplitude of less than 135pA was discarded.

All recordings were stored on computer using WinEDR software and analysed either with WinEDR or WinWCP software (University of Strathclyde). Evoked EPSC amplitudes were measured by averaging 5 individual traces.

Paired pulse ratios were calculated by dividing the peak current measurement of the second EPSC by the peak current measurement of the first EPSC (average of 10 individual stimulations).

AMPA:NMDA were calculated by dividing the peak current measurement at 5ms post-stimulation (at which time the current was shown to be predominantly AMPA-mediated) by the current measurement at 50ms post-stimulation (at which time the current was shown to be predominantly NMDA-mediated). An average of 5 individual stimulations was used for each measurement. AMPARs and NMDARs display very different channel kinetics as can be seen in Figure 2.4. Such a difference in kinetics means that a measure of the AMPA and NMDA components is possible through simply measuring the compound EPSC at the correct time points. These time points were selected using data obtained by adding 50 μ M D-APV to the bathing solution for at least 5 minutes to block NMDAR mediated currents. The dashed lines in Figure A.16 show the two selected time points of 7ms post stimulation and 55ms post stimulation. Using this approach to measuring AMPA:NMDA has the distinct advantage that both the AMPA and NMDA components are measured at exactly the same time. This is important as it means that the cell only has to be held at +40mV for short periods of time. This means

that any intracellular process triggered by such a strong, sustained depolarising signal will have a minimal effect (unlike the D-APV subtraction method, where data are reliant on no intrinsic changes to the recording taking place in the time during which D-APV treatment takes place – cells are held at +40mV for >10 minutes).. This approach also eliminates variation in the results due to changes in series resistance or recording stability when switching between -60mV and +40mV. On the other hand this approach has the disadvantage of not being able to separate the effects of changes in peak amplitude from changes in channel kinetics (such as would be predicted to happen due to changes in sub-unit composition).

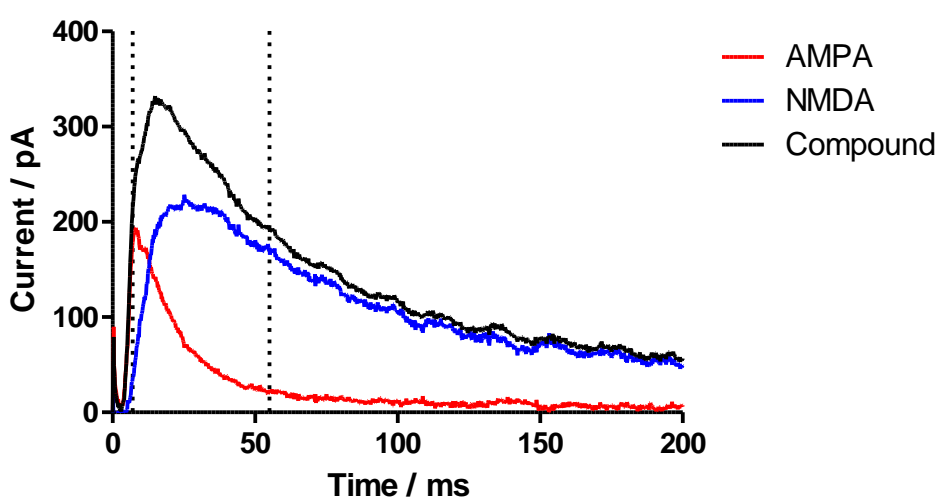

Figure 2.4 Selection of time points for the measurement of AMPA:NMDA.

A single experiment used in the calculation of time points for AMPA and NMDA measurements. Time zero in this graph is the time of stimulation. Dotted lines along the x-axis at 7 and 55 ms post stimulation represent the chosen times to measure AMPA and NMDA currents respectively. The black line (compound AMPAR/NMDAR-mediated current) is the recorded current at +40mV. The red line (AMPA-mediated current) is the resulting current also at +40mV after 10 minutes in 50 μ M D-APV. The blue line (the NMDAR-mediated current) was calculated by subtraction of the red line from the black line. All recordings made in slices taken from naive C57BL/6J mice and stimulated to produce 50% of the maximum amplitude EPSC.

Figure 2.4 shows a representative trace of 4 recordings used to derive the parameters from which time-points for AMPA and NMDA components of the EPSC were derived. This approach was therefore taken for all AMPA:NMDA measurements shown in Chapter 4 Figure 4.2.

Miniature EPSCs (mEPSCs) and miniature IPSCs (mIPSCs) were recorded by continuous recordings for at least 30 seconds. They were identified by their general waveform, a very fast rise time (approx 3ms) followed by a much slower exponential decay time (approx 10ms), and with an amplitude of at least 5pA. All mEPSC and mIPSC rise times were taken as time taken between 10% and 90% of event peak. Only those events that did not overlap with other events were recorded both for event amplitude and event rise time quantification. mEPSC decay times were measured as time taken for event to decay to 10% of peak response. Only those events where a 2nd event did not overlay onto the decay of the first were quantified. mIPSC were measured as time taken for event to decay to 50% of peak response. Only those events where a 2nd event did not overlay onto the decay of the first were quantified (time taken to decay to 10% was not feasible for mIPSCs for because of this, as the frequency of events was too high).

Comparisons of mIPSCs and mEPSCs between groups were made by using Kolmogorov-Smirnov tests. Within each treatment group, the same number of events recorded from each neurone was pooled to avoid data being skewed towards neurones with the highest mEPSC or mIPSC frequencies.

2.4 *Drugs*

All drugs used were dissolved in either water or DMSO at 1000 times their required final concentration and frozen before storage. Before use all drugs were thoroughly thawed for at least one hour at room temperature before being diluted in ACSF to their required concentrations. CNQX and APV were purchased from Tocris, tetrodotoxin was purchased from Ascent Scientific and all other compounds and salts were purchased from Sigma-Aldrich

2.5 *Solutions*

Artificial Cerebrospinal Fluid (ACSF)

125 mM	Sodium Chloride
2.5 mM	Potassium Chloride
1.2 mM	Monosodium Phosphate

1.2 mM	Magnesium Chloride
2.4 mM	Calcium Chloride
21.4 mM	Sodium Bicarbonate
11.1 mM	D-Glucose
0.1 mM	Ascorbic Acid

Cutting Solution

19 mM	Sodium Chloride
2.5 mM	Potassium Chloride
1.2 mM	Monosodium Phosphate
7 mM	Magnesium Chloride
0.5 mM	Calcium Chloride
15 mM	Sodium Bicarbonate
6.2 mM	D-Glucose
21 mM	Sucrose

Intracellular Solution A

63 mM	Caesium Fluoride
56 mM	Caesium Methanesulphonate
8.3 mM	Sodium Chloride
8.4 mM	4-(2-hydroxyethyl)-1-piperazineethanesulfonic acid (HEPES)
0.5 mM	Ethylene glycol tetraacetic acid (EGTA)
5 mM	<i>N</i> -(2,6-Dimethylphenylcarbamoylmethyl)triethylammonium bromide (QX314)

CsOH was then added to the solution until it reached a pH of 7.3.

This gave a solution of osmolarity ~285 mOsM

Intracellular Solution B

120 mM	Caesium Methanesulphonate
10 mM	Sodium Chloride
2 mM	Magnesium Chloride
10 mM	4-(2-hydroxyethyl)-1-piperazineethanesulfonic acid (HEPES)

0.5 mM Ethylene glycol tetraacetic acid (EGTA)
5 mM *N*-(2,6-Dimethylphenylcarbamoylmethyl)triethylammonium
bromide (QX314)
2 mM Mg-ATP
0.25 mM Na-GTP

CsOH was then added to the solution until it reached a pH of 7.3.

This gave a solution of osmolarity ~285 mOsM

**Chapter 3: Investigating the
Effects of Morphine and
Morphine-induced Place
Preference on the Functioning of
Hippocampal CA1 Synaptic
Transmission using Field
Recordings.**

3.1 Introduction

The overall aim of this thesis is to investigate synaptic plasticity changes in the hippocampus that are induced by or underlie addiction-related behaviour. Initially, experiments were performed to investigate potential changes in *ex vivo* stimulus-induced LTP and LTD after the demonstration of drug seeking behaviour.

Animals were first treated with morphine (administered either non-contingently or during place preference training), then killed and slices prepared. The ability of stimulus-induced LTP and LTD to be induced in slices taken from these animals was measured using field recordings. Comparing the effects of these treatments relative to their appropriate vehicle controls allowed for the investigation of changes in synaptic function that were unique to the drug-induced behavioural change.

There are conflicting reports concerning the effects of non-contingent morphine on stimulus-induced LTP. Studies either report an attenuation (Pu *et al.* 2002; Bao *et al.* 2007 ; Lu *et al.* 2010; Xia *et al.* 2011) no change (Salmanzadeh *et al.* 2003; Billa *et al.* 2010) or an augmentation (Mansouri *et al.* 1999). There are a number of possible reasons for these contradictory findings. The injection paradigms used in many of these studies were sufficient to produce tolerance and withdrawal, these processes may interfere with the induction of LTP. Another possibility is that depending on precise details of the injection procedure, environmental cues may have become predictive of morphine administration. In this case, associative learning processes dependent on the hippocampus may have effects on the subsequent induction of LTP. While Xia *et al.* (2011) did attempt to control for this, their injection paradigm was more intense than the current paradigm and the subject was killed 90 minutes after the last injection of morphine.

To date only limited data exists for the specific effects of morphine-induced place preference in the hippocampus. While none of it demonstrates any functional adaptations, AMPA surface expression may be increased after morphine CPP but not morphine administered non-contingently (Moron *et al.* 2010). This finding suggests that the associative learning processes may induce LTP mechanisms in

the hippocampus. Prior *in vivo* LTP induction (such as the insertion of AMPARs suggested above) may occlude further stimulus-induced LTP through saturation of these expression mechanisms (Pu *et al.* 2002). The observed effect of prior *in vivo* LTP induction on stimulus-induced LTP would therefore be one of attenuation. For more detail on this hypothesis see section 3.3 and Figure 3.17.

Changes in stimulus-induced LTP can have alternative explanations to the one outlined above however, such as metaplastic changes. Metaplasticity is an adaptation in the state of the synapse that, while not effecting the probability of transmission, does affect the induction of plasticity. For example, the observed attenuation in stimulus-induced LTP (Pu *et al.* 2002; Bao *et al.* 2007 ; Lu *et al.* 2010; Xia *et al.* 2011) could equally be due to a reduction in the prior *in vivo* activation of group I mGluR receptors, as prior activation of these receptors may be an induction requirement of LTP (Bashir *et al.* 1993 and see section 1.7.1). Therefore changes in stimulus-induced LTP between treatment groups may have more than one interpretation and further evidence is needed to support one hypothesis over the other.

The initial aim of the following experiments was to demonstrate an effective method for stimulus-induced synaptic plasticity. After this a method for the induction of conditioned place preference to morphine also had to be developed. Then the effects of the two treatment paradigms, non-contingent morphine and morphine-induced place preference could be compared. The results presented below suggest that similar but subtly different processes occur in CA1 in response to morphine treatment when to used to induce place preference compared to non-contingent administration.

3.2 Results

Field EPSPs were recorded from the dendritic layer of CA1 hippocampal slices following stimulation of Schaffer collateral afferent fibres. Care was taken to standardise the placement of both stimulating and recording electrodes in each slice (see section 2.3.2). Initially, input-output curves were generated, to derive a stimulus intensity that produced a 50% maximal fEPSP slope. This was then used for the ensuing recording.

3.2.1 Stimulus-induced long-term potentiation (LTP) and long-term depression (LTD)

In control, untreated slices, both long-term depression (LTD) and long-term potentiation were induced. First, a 20-minute baseline recording was performed (0.05Hz stimulation). Immediately after this 20-minute period fEPSP slopes were analysed. If the baseline period was unstable (defined as a standard deviation less than 5% and no obvious continuous increase or decline in fEPSP slope within 20 consecutive minutes), then this was repeated until a stable baseline was achieved. Then, either LTD was induced by low-frequency stimulation (LFS) or LTP was induced by theta-burst stimulation. Immediately following LFS or theta-burst, the fEPSP slope was recorded at 0.05 Hz for a further 60 minutes.

Figure 3.1 shows data (n=7) from theta-burst stimulation, and Figure 3.2 shows data from LFS stimulation. While the LTP induced by theta-burst stimulation was robust with a reasonable degree of variation (mean fEPSP slope at 70 minutes: 64% above baseline (standard deviation: 29%)), LTD induced by LFS was small, with a high degree of variability. Indeed, although noticeable LTD could be recorded in around half of the slices tested (4 of 7 slices), no LTD was produced in the others (3 of 7 slices), overall, there was no significant LTD induced (mean fEPSP slope at 70 minutes: 0% below baseline (standard deviation: 24%)). For this reason, only stimulus-induced LTP was used for the rest of the experiments shown in this chapter.

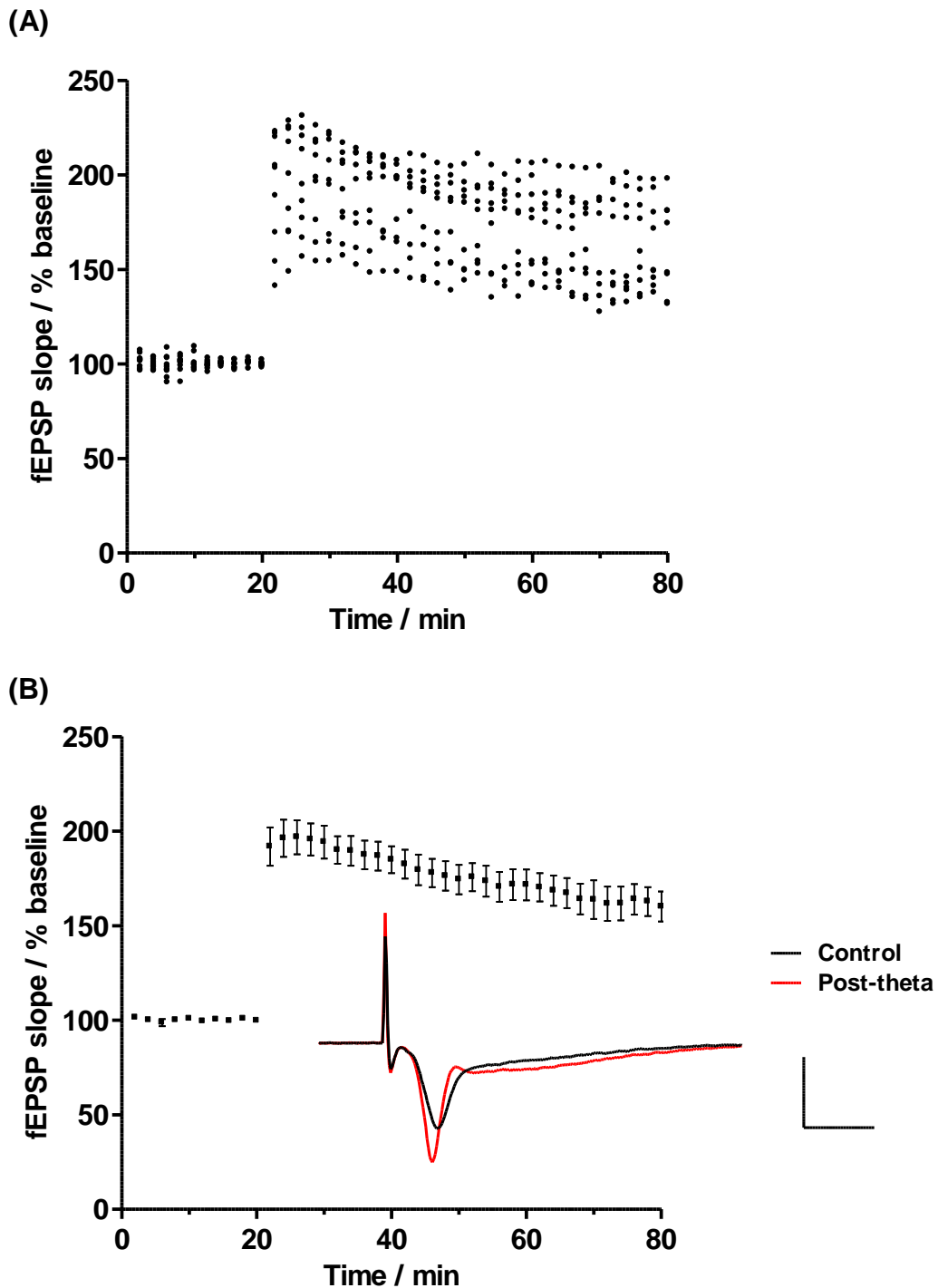

Figure 3.1 Stimulus-induced long-term potentiation (LTP).

fEPSPs were recorded from the dendritic layer of the CA1 hippocampal region, following Schaffer Collateral stimulation. Stimulus intensity was set at 50% maximum throughout. Following a 20 minute baseline period a theta-burst stimulation was applied that resulted in LTP in 9/9 slices. All data shown as normalised to field EPSP slope during baseline period. (A). Scatter plot showing all recordings, (B) averaged data (Mean \pm S.E.M; n = 9), also included is a representative trace showing fEPSP recording before and 20 minutes after the theta-burst stimulation protocol. Calibration bars are set to 5ms and 2mV.

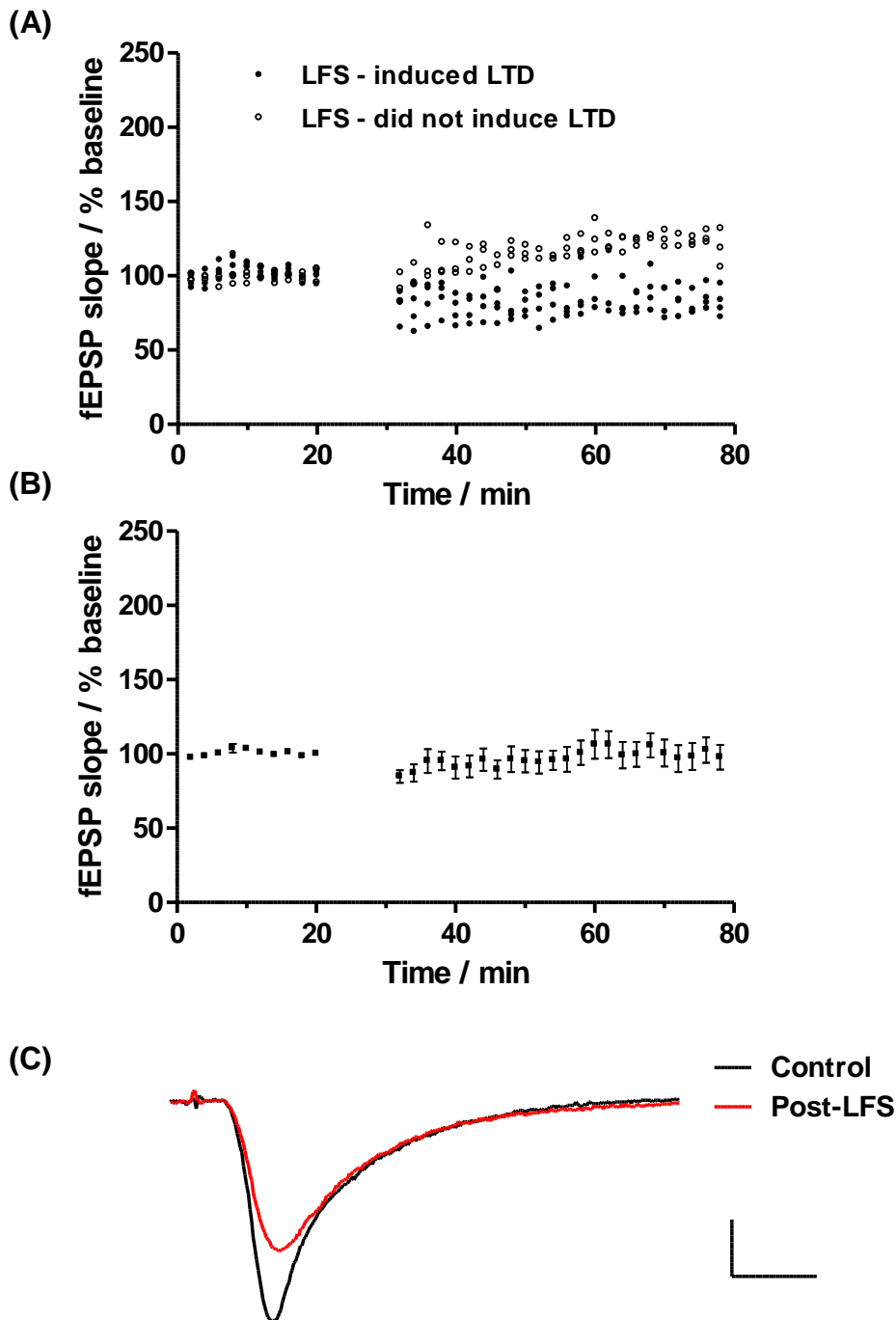

Figure 3.2 Stimulus-induced long-term depression (LTD).

fEPSPs were recorded from the dendritic layer of the CA1 hippocampal region, following Schaffer Collateral stimulation. Stimulus intensity was set at 50% maximum throughout. Following a 20 minute baseline period a low-frequency stimulation was applied. In 4 out of 7 slices, this resulted in LTD, but no LTD was observed in 3 out of 7 slices. All data shown as normalised to field EPSP slope during baseline period. (A). Scatter plot showing all recordings (B) averaged data (Mean \pm S.E.M; $n = 7$) (C) Trace showing successful LTD induction of fEPSP slope. Recording taken before and 20 minutes after the low frequency stimulation (LFS) protocol. Calibration bars are set to 5ms and 0.5mV.

3.2.2 Morphine-induced conditioned place preference (MOR CPP)

In order to investigate the effects of drug-context associations on stimulus-induced LTP in CA1, the place preference model was selected. This was due to the need for young animals and low drug doses (see Introduction; section 1.12). After optimisation (see appendix, section A.1) a biased, unbalanced protocol was arrived at. There are a number of theoretical issues with this type of place preference protocol (Bardo and Bevins, 2000), something that is discussed in more detail in the Appendix. MOR CPP is a well established phenomenon however and the only objective here was to demonstrate that the mice had learnt an association between the drug and one specific environment.

Figure 3.3 shows the demonstration of a morphine-induced place preference in C57BL/6J mice. The preference score was calculated by subtracting the total time spent in the saline paired environment from the total time spent in the morphine paired compartment. A positive value therefore indicates a preference for the drug-paired compartment whereas a negative value represents a preference for the saline paired compartment. A 2-way ANOVA comparing the effects of training and drug with Bonferroni post tests revealed the MOR CPP group had a significant increase in preference for the drug-paired compartment on the test day compared to the pre-test day ($P < 0.01$) whereas the SAL CPP group did not ($P > 0.05$). This was also true when tested again 3 days later ($P < 0.05$). After 7 days a further test suggested the MOR CPP group still spent longer in the drug-paired compartment compared to the pre-test, although this effect was not significant (t-test, $P = 0.2$, $n = 8$). One possible reason for this was the large variation observed in the +7 days MOR CPP group (SD of 173 seconds at +7 days compared to 59 seconds at pre-test). Another possible reason for the general decreasing trend in preference over repeated testing was the process of extinction. CPP has been previously shown to be long lasting (at least 12 weeks, Mueller *et al.*, 2002) but progressively declines following repeated exposure to the CPP environments in the absence of contingent drug administration, a process known as extinction (Mueller and Stewart, 2000). Slices were therefore taken from animals on the test day, and 3-, 4-, 5-, or 6-days after the test.

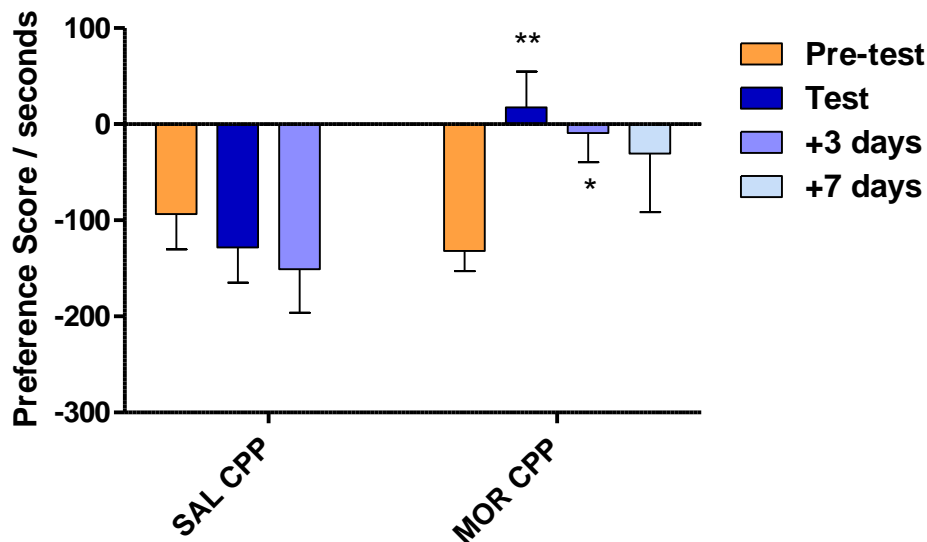

Figure 3.3 Morphine-induced conditioned place preference (CPP).

Mice were exposed to the conditioned place preference apparatus and baseline preference measured (pre-test). Mice were then assigned to treatment groups. No saline-induced CPP was observed, but morphine-induced CPP was seen as a significant increase in preference score (time spent in morphine-paired environment on test-day minus time spent in the saline paired environment) compared to SAL CPP. Upon retesting for preference, animals still showed significant morphine-induced CPP preference 3 days after training, with a non-significant trend at 7 days. Saline-treated animals were unchanged. Data is presented as mean \pm S.E.M. $**=P<0.01$, $*=P<0.05$ compared to pre-test score, 2-way ANOVA with Bonferroni post-tests. $n = 8$ per treatment group.

3.2.3 Effects of morphine treatment and morphine CPP training on stimulus-induced LTP

Next, animals were treated *in vivo* with 4 different regimens, prior to slices being taken and stimulus-induced LTP measured. Treatment groups were: SAL (animals were administered 4 daily injections of saline and confined to home cage), MOR (animals were given 2 injections of morphine (10 mg kg^{-1}) and 2 injections of saline (10 ml kg^{-1}) alternately over 4 days and confined to home cage), SAL CPP animals were administered the same injections as the 'saline' group but were exposed to the conditioned place preference boxes immediately after injections, MOR CPP animals were trained to demonstrate morphine conditioned place preference and so received the same injections as the MOR group, but with exposure to the conditioned place preference boxes. Thus there were both contingent and non-contingent morphine treatments with vehicle controls.

Figure 3.4 shows that non-contingent morphine leads to a reduction in stimulus-induced LTP at time points more than 22 minutes after LTP induction (by repeated t-tests, $P < 0.05$). Although various conflicting effects of non-contingent *in vivo* morphine treatments on *ex vivo* LTP induction have been demonstrated (see section 3.1), the finding that *in vivo* morphine treatments can result in a decrease in stimulus-induced LTP has been previously demonstrated by some groups (see Xia *et al.* 2011; Pu *et al.* 2002; Lu *et al.* 2010; Bao *et al.* 2007).

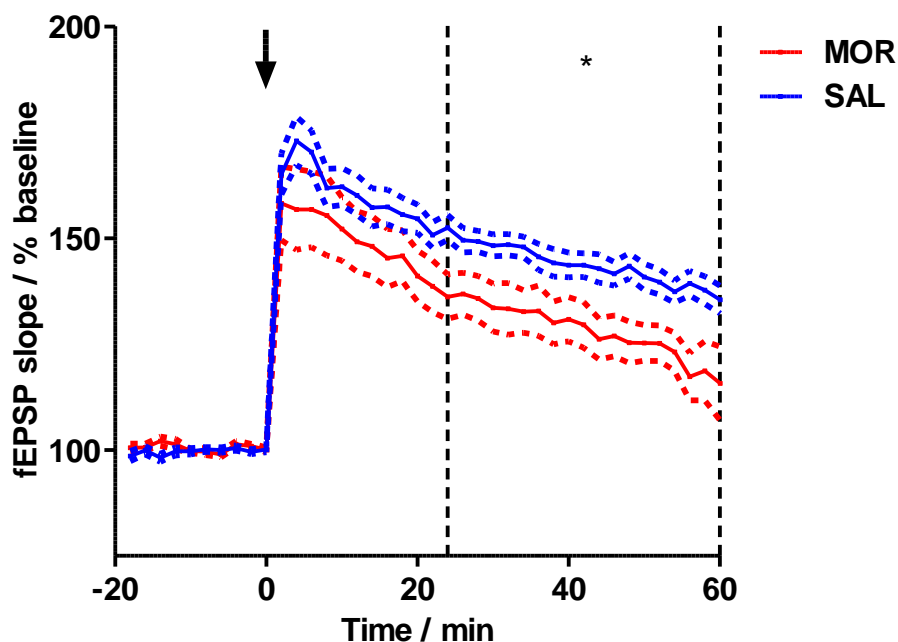

Figure 3.4 Effect of non-contingent morphine on stimulus-induced LTP

Mice were treated with MOR or SAL. Slices were taken 24 hours after last injection and stimulus-induced LTP was recorded following theta-burst stimulation. All data shown as normalised to fEPSP slope during baseline period. Symbols show mean values, dotted lines represent S. E. M. n = 12-16. Repeated unpaired t-tests revealed that fEPSP slopes at each time-point between 24 and 60 minutes were significantly different ($P < 0.05$). Arrow represents time of theta-burst induction.

When the same morphine injections were administered in the context of MOR CPP training, this difference was no longer apparent, with no significant difference between SAL and MOR CPP treatment groups (Figure 3.5). Figures 3.4 and 3.5 suggest that while non-contingent morphine treatment led to a reduction in the ability of theta-burst stimulation to induce LTP, the same drug injections given in the context of CPP training had no effect.

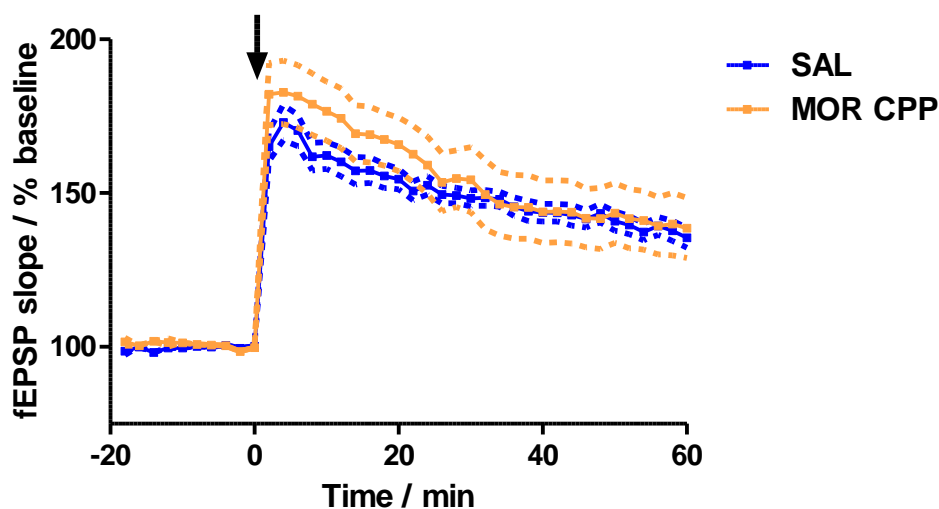

Figure 3.5 Effect of morphine-induced conditioned place preference training on stimulus-induced LTP

Mice were trained to demonstrate MOR CPP or treated with SAL. Slices were taken and stimulus-induced LTP was recorded following theta-burst stimulation. All data shown as normalised to field EPSP slope during baseline period. Symbols show mean values, dotted lines represent S. E. M. $n = 16-17$. Unpaired t -test revealed that fEPSP slopes were not significantly different at any time-point ($P > 0.05$) although a significant difference in variance between groups invalidated this test. Arrow represents time of theta-burst induction.

A number of possible reasons could account for these differences seen between contingent and non-contingent morphine. One possibility was that morphine given in a specific context (MOR CPP) could trigger different mechanisms when compared to morphine given in the absence of any specific cue (MOR). Another possibility was that the CPP training had its own effects that were either masking or reversing the effects of morphine. To further investigate these hypotheses the effects of SAL CPP were examined.

3.2.4 Effects of conditioned place preference training with saline injections on stimulus-induced LTP

Figure 3.6 shows that, surprisingly, SAL CPP increases stimulus-induced LTP compared to SAL treatment alone. This suggests that conditioned place preference training itself induces changes in synaptic function, regardless of any drugs used to induce a preference. T-tests revealed that SAL CPP training (which

in itself did not induce any evident conditioned place preference behaviour, see Fig. 3.3) resulted in a significant increase in stimulus-induced LTP ($P < 0.05$).

Considering only figures 3.4 and 3.5, it appears that although non-contingent morphine induces a persistent deficit in the ability of theta-burst stimulation to induce LTP, when the same morphine/saline injections are given in the context of conditioned place preference training, this difference is no longer evident. This was a somewhat surprising finding, but did suggest that the failure to observe a change in stimulus-induced LTP in other studies (Salmanzadeh *et al.* 2003; Billa *et al.* 2010) could have been due to unintended associative learning processes. Comparing the effects of MOR and MOR CPP to their appropriate controls (SAL and SAL CPP respectively, Figure 3.7) reveals that morphine reduces stimulus-induced LTP in both situations (SAL vs MOR, $P < 0.05$ between 26 and 60 minutes post LTP induction; SAL CPP vs MOR CPP, $P < 0.05$ between 20 and 56 minutes post LTP induction, Figure 3.7).

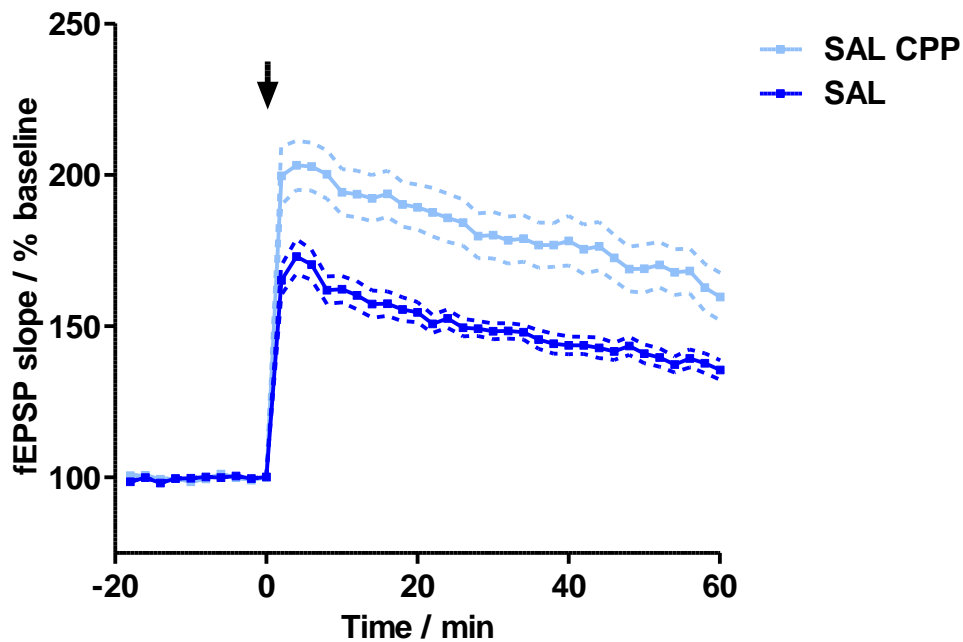

Figure 3.6. Effect of CPP training in the absence of morphine administration on stimulus-induced LTP.

Mice underwent either SAL or SAL CPP treatment before LTP induction. All data shown as normalised to field EPSP slope during baseline period. Symbols show mean values, dotted lines represent S. E. M. This graph shows a clear increase in stimulus-induced LTP following SAL CPP compared to SAL ($P < 0.05$ for all times post stimulation) although again an increase in variance invalidated this result. Another problem with this interpretation is the duplication of the SAL treatment group in figures 3.4 and 3.5. While this method increases the chances of type I errors, there is a clear difference between these two groups (see below for a further discussion).

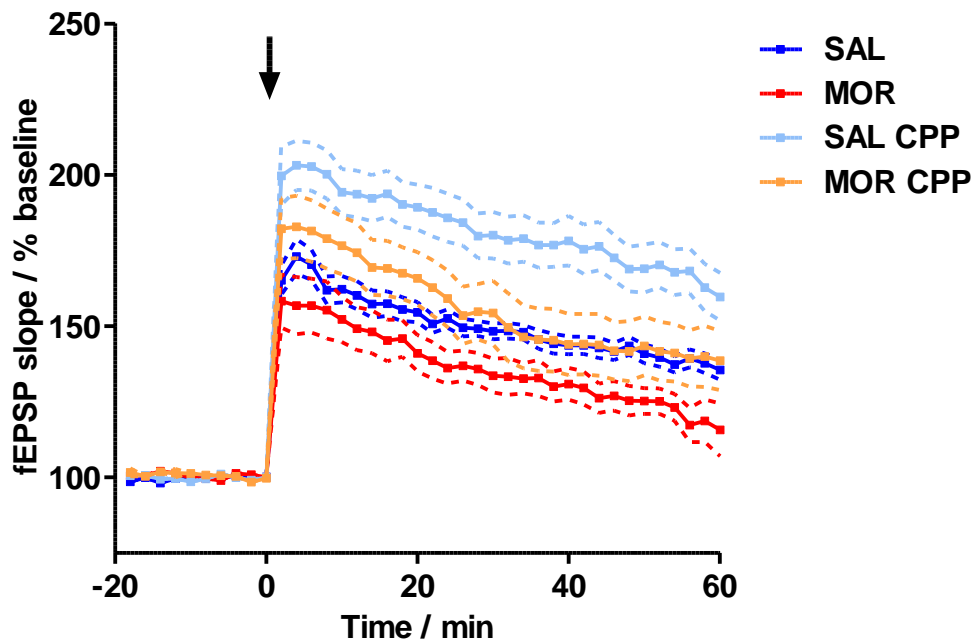

Figure 3.7 Overall effects of morphine and conditioned place preference training on stimulus-induced LTP.

Slices were taken and stimulus-induced LTP was recorded following theta-burst stimulation. Arrow represents time of theta-burst induction. All data shown as normalised to field EPSP slope during baseline period. Symbols show mean values, dotted lines represent S. E. M. n = 12-17. Arrow represents time of theta-burst induction.

The data presented above utilises repeated t-tests to search for potential differences between defined groups. While within each graph each data point is only involved in one t-test, further comparisons lead to individual data points being used for more than one t-test. Using the same data for more than one t-test increases the chances of type 1 errors (the detection of a difference where there is none). One way around this is to use ANOVAs to make multiple comparisons between groups. Doing this however does reduce the power of the tests to detect differences (increasing the chances of a type II error). One of the validation procedures for one way ANOVAs is to use Bartlett's test to confirm that the variation amongst the different populations being compared is the same (Bartlett, 1937). Choosing 50 minutes post theta burst as an example time point, Bartlett's test produces a P value of <0.0001 . This low value invalidates the use of ANOVAs or students' t-tests to compare means. The data shown in Figures 3.4 – 3.7 were displayed in the conventional manner of plotting mean \pm S.E.M. As the standard error of the mean generally decreases as sample size increases (S.E.M. = standard deviation divided by the square root of the sample size) then this variation is harder to see. Figure 3.8 highlights this, by plotting all data points (at time 50 minutes) as a scatter plot with mean and standard deviation values (rather than S.E.M.) shown. Here, it can clearly be seen that the variability of the data derived from morphine CPP- and saline CPP-treated animals was distinctly higher than data derived from non-contingently-treated animals. Indeed, the Fisher-Snedecor distribution-test (F-test) can be used to assess whether the variance and standard deviation of two datasets are significantly different from each other. Performing this test reveals the MOR CPP data is significantly more variable than the MOR data (MOR: variance = 215, standard deviation = 15; MOR CPP: variance = 1602, standard deviation = 40. F-test = 0.002). Similarly, there is a significant difference between SAL and SAL CPP (non-contingent saline: variance = 154, standard deviation = 12; saline CPP: variance = 818, standard deviation = 29. F-test = 0.003). There was no significant difference in variability between the SAL and MOR groups (F-test = 0.54) or the SAL CPP and MOR CPP groups (F-test = 0.24).

An apparent increase in variability could be caused by the presence of outliers in the dataset. Therefore Grubb's test was used to examine whether there was a

statistically-significant outlier which may result in an apparent increase in variability, but no significant outliers were identified in any data set.

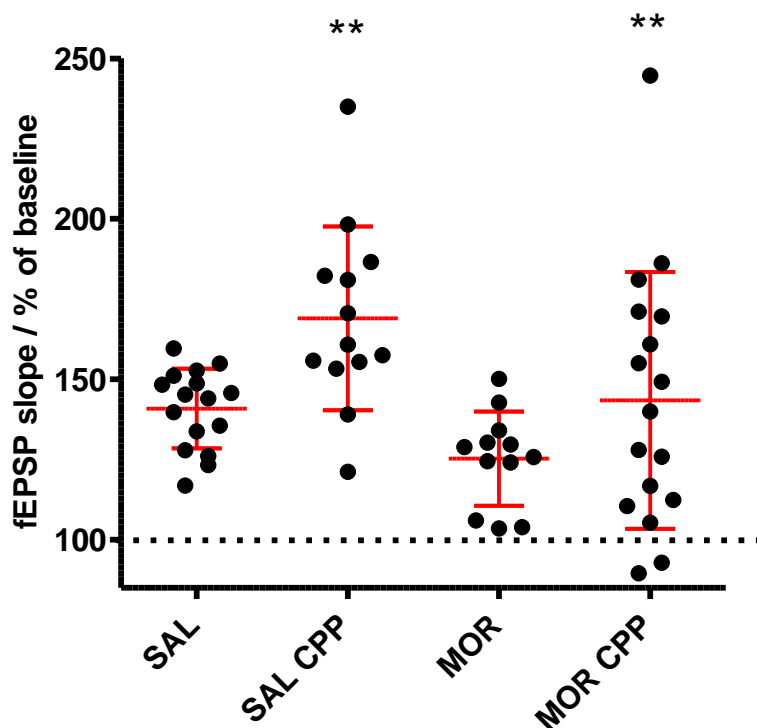

Figure 3.8 Increased variability of stimulus-induced LTP following conditioned place preference training

*Mice received in vivo treatments: non-contingent saline ('saline'), non-contingent morphine ('morphine'), morphine conditioned place preference ('morphine CPP') or saline conditioned place preference ('saline CPP') and stimulus-induced LTP was measured. Data show scatter plot of stimulus-induced LTP 50 minutes post-theta-burst. All data shown as normalised to field EPSP slope during baseline period. Red central line represents mean values, error bars are standard deviation. F-test shows significantly increased variability in both the morphine CPP groups and saline CPP groups when compared to MOR and SAL respectively. ** = $P < 0.01$, F-test for equal variance.*

A Student's t-test with Welch's correction can be used to analyse potential differences between the means of two populations with different variances (Welch, 1947), such as the MOR and MOR CPP groups. Figure 3.9 shows that there is indeed a significant increase in the ability of theta-burst stimulation to induce LTP in the MOR CPP group compared with the MOR group using Welch's correction

(which is the correct form of statistical analysis when 2 data-sets have significantly different variances) between 12 and 24 minutes post-theta-burst. There was a non-significant trend at the other time points (for example, $P = 0.053$ at 56 minutes post-theta-burst (time = 76 minutes)). Similarly, when the SAL and SAL CPP groups were reanalysed using Welch's correction, the significant increase in LTP induction in the saline CPP group compared with the non-contingent saline group (see Figure 3.6) was still evident ($P < 0.05$ at times 0-60 minutes).

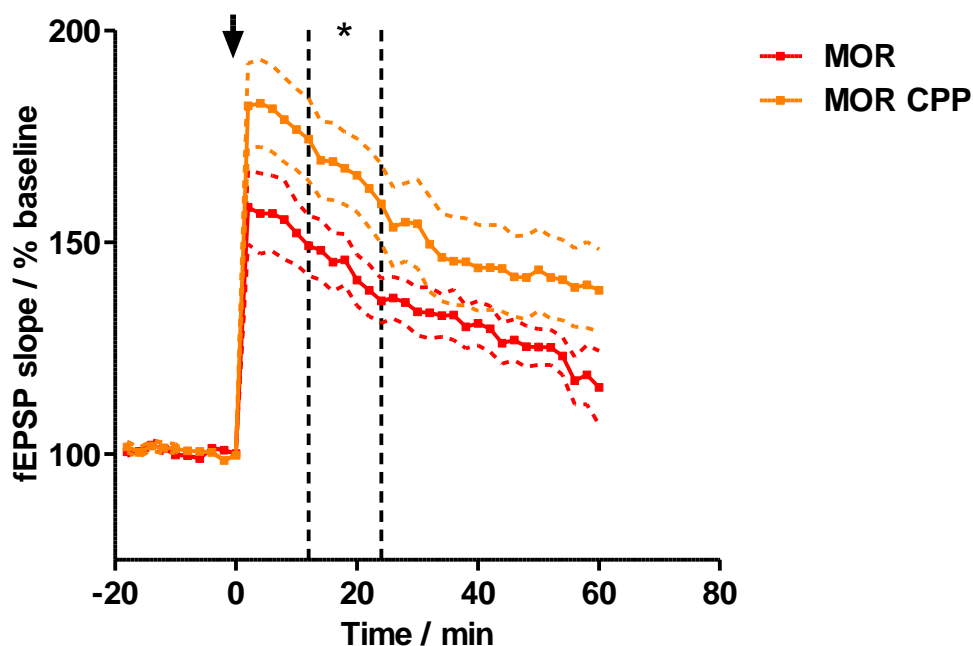

Figure 3.9 Comparison of stimulus-induced LTP following MOR and MOR CPP.

*Stimulus-induced LTP was measured by administering a theta-burst at time zero. Data shown as mean \pm S.E.M. $n=16-19$. Vertical dashed lines and * indicate time period within which groups were statistically different using t -test with Welch's correction ($P < 0.05$, 12-24 minutes post LTP induction). Arrow indicates time of theta-burst induction. Overall, morphine treatment, whether administered in the context of CPP or in the absence of any specific cue results in a significant decrease in the ability of theta-burst stimulation to induce LTP. Whereas CPP training itself (whether morphine is administered or not) results in a significant increase in the ability of a theta-burst to induce LTP. Also, there is a significant increase in the variability of stimulus-induced LTP in slices taken from animals that had undergone conditioned place preference training (whether saline or morphine was administered) when compared with animals that had undergone identical injection regimens but were confined to their home cage.*

As mentioned in the introduction to this chapter, changes in stimulus-induced LTP can have more than one interpretation. It was therefore necessary to further investigate these changes using higher resolution techniques before any attempts were made to interpret these findings. These experiments are presented in Chapters 4 and 5.

3.2.5 Investigating the mechanisms underlying increased variability of responses after morphine CPP

Animals that had undergone conditioned place preference training were exposed to a novel environment (the conditioned place preference equipment), and may therefore have had a more stressful experience than those that just received non-contingent injections (or *vice versa*). Indeed, there is evidence that stress can cause subsequent changes in the amount of stimulus-induced LTP in *ex vivo* slices (Kim *et al.* 1996). Because of the constraints of the Home Office project licence it was not possible to deliberately induce stressful situations, therefore this hypothesis was tested by studying stimulus-induced LTP in completely separate group of animals. The two treatment groups were non-contingent saline animals (SAL treatment regime) and animals that were left completely unhandled before being killed. Figure 3.10 shows that although there is a trend to a decrease in stimulus-induced LTP in the saline group compared with the naïve group, this is not statistically significant (SAL vs Naive, $P > 0.05$ at all time points following LTP induction using a unpaired t-test). If increased levels of stress were responsible for the apparent increase in stimulus-induced LTP in SAL CPP, then it would be expected that non-contingent saline would also cause an increase in stimulus-induced LTP compared with untreated, naïve animals, which was not the case.

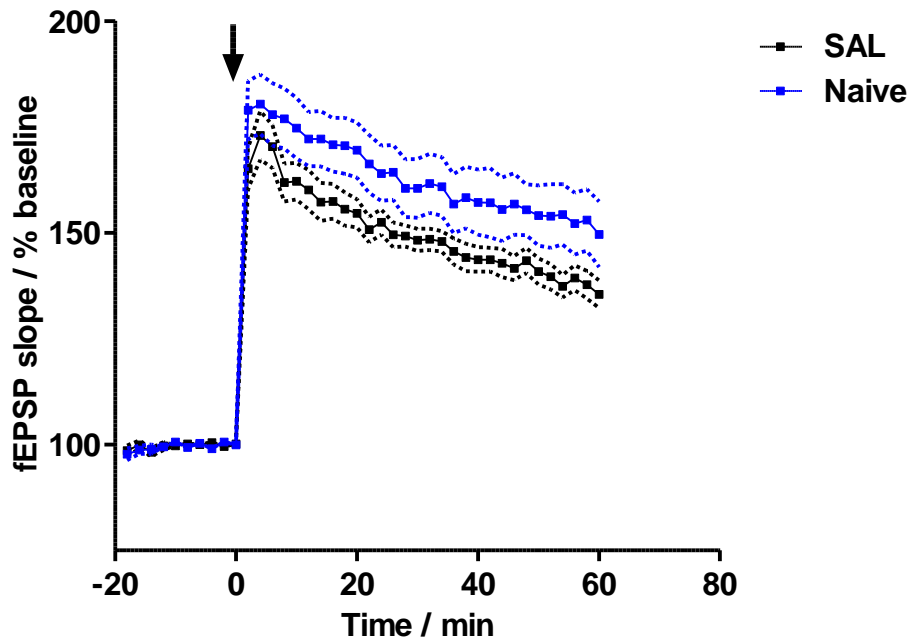

Figure 3.10 Comparison of stimulus-induced LTP following non-contingent saline treatment and untreated animals

Mice were treated with saline ‘non-contingently’ over 4 days (‘saline’) or were left completely untreated and were not handled for the same length of time (‘naïve’). Slices were then taken and stimulus-induced LTP was recorded following theta-burst stimulation at time = 20 minutes. All data shown as normalised to field EPSP slope during baseline period. Symbols show mean values, dotted lines represent S. E. M. n = 16-19. Unpaired t-test revealed that fEPSP slopes at each time-point were not significantly different from each other ($P > 0.05$) although SAL treatment did show a trend to increase fEPSP slopes post theta burst.

In the data shown above (figures 3.4-3.9), animals were treated *in vivo* for 4 days, and then killed and slices taken from them either on the test day (1 day), or 4, 5, 6 or 7 days after the last injection. We (Figure 3.3) and others have shown that conditioned place preference to morphine (and to other drugs of abuse) persists for at least 1 week, even as long as several months (Mueller *et al.*, 2002). Assuming that these changes in behaviour are correlated to changes in synaptic transmission, then those changes may also persist for at least one week. Based on this assumption, no attempt was made to restrict recordings taken only from animals on the test day. There is evidence however, that information stored in the hippocampus is gradually consolidated to other brain regions over time (Debiec *et al.* 2002), and therefore perhaps this ‘systems consolidation’ could be responsible for the observed variability. To test this hypothesis, evidence for a correlation

between time since *in vivo* training and magnitude of LTP induction was examined. For example, perhaps those slices where a very high degree of stimulus-induced LTP was induced were taken from animals 6 days after cessation of behavioural treatment, whereas those exhibiting a low degree of stimulus-induced LTP may be from slices taken from animal on the test day (or vice versa). Figure 3.11 shows that this is not the case, as there is no correlation between the time after the end of behavioural training and slice preparation versus magnitude of stimulus-induced LTP.

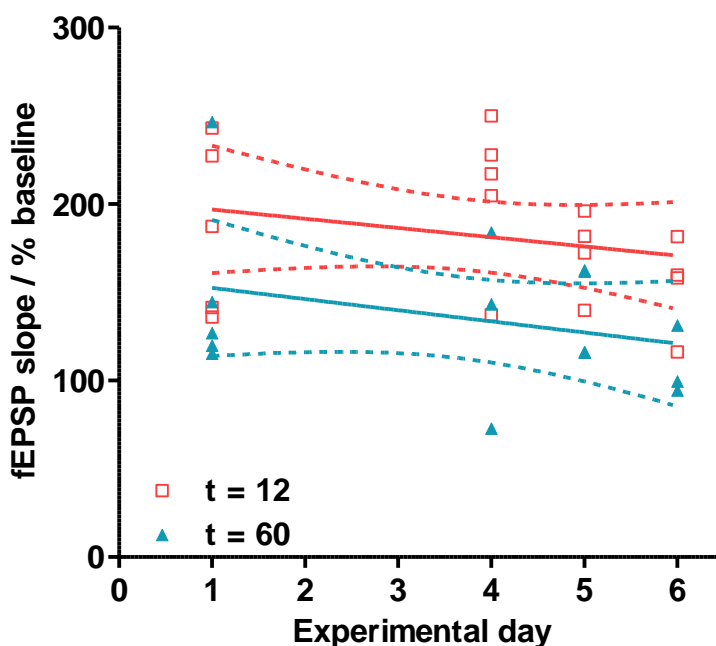

Figure 3.11 Correlation plot of time-lag between end of behavioural treatment and ex vivo stimulus-induced LTP.

All mice underwent morphine-induced conditioned place preference training, with the CPP test day on 'day 1', slices were taken from these animals on days 1, 4, 5 or 6 and stimulus-induced LTP induced by theta-burst stimulation. Data plotted as fEPSP slope (normalised to baseline slope) at time = 12 minutes (ie. 12 minutes post-theta burst) (blue triangles) or at time = 60 minutes (ie. 60 minutes post-theta burst) (red squares). Linear regression analysis was then performed; solid line is line of best-fit, dashed lines are 95% confidence band of regression line. There was no significant correlation between experimental day and magnitude of stimulus-induced LTP. At time = 12 minutes, $r^2 = 0.06$, $P = 0.31$ for statistical deviance of line-of-best-fit from zero. At time = 60 minutes, $r^2 = 0.10$, $P = 0.26$ for statistical deviance of line-of-best-fit from zero.

Alternatively, it is possible that the increased variability in stimulus-induced LTP in slices taken from animals that had undergone conditioned place preference training may be due to variability in the magnitude of conditioned place preference behaviour expressed by that animal, or how well that animal has learned the task. As animals that had undergone saline conditioned place preference expressed no overt change in behaviour (see Figure 3.3) we tested this hypothesis by examining a possible correlation between magnitude of stimulus-induced LTP and the magnitude of morphine-induced conditioned place preference behaviour (ie. magnitude of increase in time spent in morphine-conditioned environment). Figure 3.12 clearly shows that there was no such correlation, nor significant deviation of the line of best-fit from zero, between conditioned place preference behaviour and magnitude of stimulus-induced LTP. Therefore, the variability in how well an animal learned the conditioned place preference task does not appear to underlie the variability in subsequent stimulus-induced LTP in slices taken from that animal.

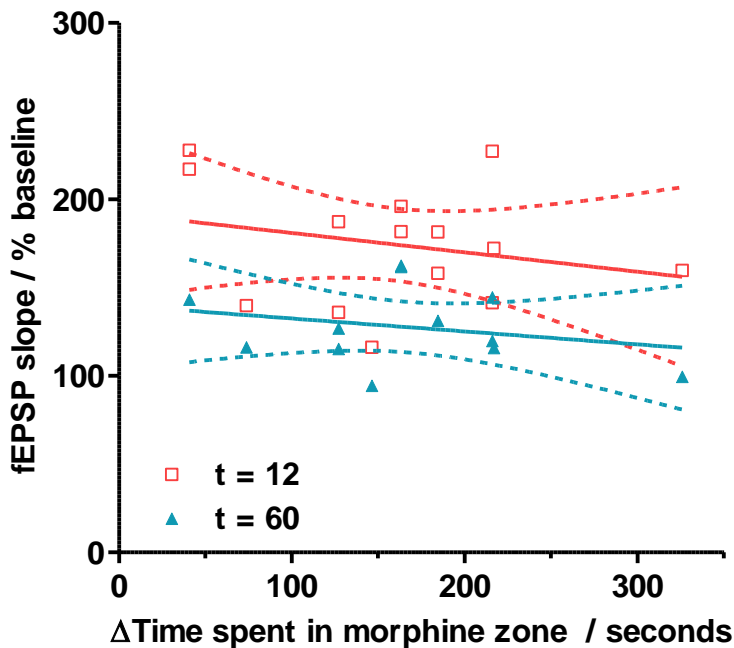

Figure 3.12 Correlation plot of conditioned place preference behaviour and ex vivo stimulus-induced LTP.

All mice underwent morphine-induced conditioned place preference training. Degree of expressed conditioned place preference behaviour is plotted on the x axis as the difference in time spent in the morphine-conditioned side on the post-training day minus time spent in the morphine-conditioned side on the pre-training day (time in seconds). Y axis shows data plotted as field EPSP slope (normalised to baseline slope) at time = 12 minutes (ie. 12 minutes post-theta burst; blue triangles) or at time = 60 minutes (ie. 60 minutes post-theta burst; red squares). Linear regression analysis was then performed; solid line is line of best-fit, dashed lines are 95% confidence band of regression line. There was no significant correlation between experimental day and magnitude of stimulus-induced LTP. At time = 12 minutes, $r^2 = 0.06$, $P = 0.41$ for statistical deviance of line-of-best-fit from zero. At time = 60 minutes, $r^2 = 0.06$, $P = 0.44$ for statistical deviance of line-of-best-fit from zero.

Together, these data suggest that there is no correlation between the degree of expression of conditioned place preference behaviour and amount of stimulus-induced LTP. Also there appears to be no correlation between the amount of stimulus-induced LTP, and how many days post-injection the electrophysiological recordings were taken. It is therefore unclear what mechanisms underlie the increased variability in both the CPP groups.

The overall pattern of the above results (figures 3.4-3.12) is that morphine given *in vivo* (whether in a specific context or not) causes a decrease in the ability of

synapses to undergo *ex vivo* stimulus-induced LTP. Whereas prior training with the conditioned place preference behavioural paradigm, whether a rewarding substance (i.e. morphine) is used or not (i.e. saline) results in an increase in the ability of synapses to undergo stimulus-induced LTP although at this stage it is not possible to ascertain whether these changes oppose each other by being similar but opposite processes or are completely independent processes.

3.2.6 Investigating pre-synaptic effects of MOR and MOR CPP treatments

To further study the potential effects of *in vivo* conditioned place preference training and morphine on the CA3-CA1 synapses, paired pulse facilitation experiments were performed. The summation of presynaptic intracellular calcium concentration and voltage-gated calcium conductances combine to produce a processes known as facilitation (Zucker *et al.* 2002). The magnitude of facilitation has been demonstrated to be dependent on inter-pulse interval (the shorter the interval the greater the facilitation) and the release probability (P_r) of the presynaptic terminal (the lower the release probability the greater the facilitation) (Zucker *et al.* 2002).

Figure 3.13 shows the paired-pulse ratios between the different treatment groups. No significant differences exist between MOR and SAL or between MOR CPP and SAL CPP using unpaired t-tests, although comparing SAL to MOR was close to significance ($P=0.06$). Paired pulse ratios were also measured 60 minutes after theta-burst induced LTP. As when paired-pulse facilitation was measured before stimulus-induced LTP occurred, there was no significant difference in paired-pulse ratio between SAL and MOR or between SAL CPP and MOR CPP (Figure 3.14, $P>0.05$ with unpaired t-tests).

Using paired-pulse facilitation of fEPSPs as a measure of probability of transmitter release - none of the *in vivo* treatments produced a statistically-significant change when measured *ex vivo*. Further, unlike when stimulus-induced LTP was recorded, there was no significant change in variability between any of the treatment groups ($P>0.05$ F-test, for any comparison between groups).

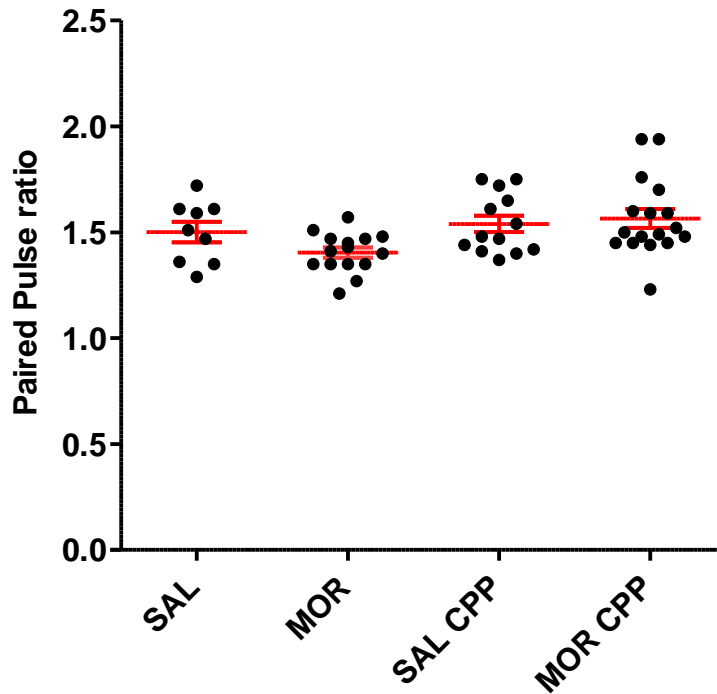

Figure 3.13 Paired-pulse facilitation following different *in vivo* treatments.

All mice underwent *in vivo* treatments (SAL, MOR, SAL CPP and MOR CPP). Two fEPSPs were evoked 50ms apart and the slopes of the ensuing fEPSPs were recorded. PPF ratios were calculated as the slope of the 2nd fEPSP divided by the slope of the 1st fEPSP. Scatter-plot shows all data points, red central line represents mean value with error bars of S.E.M. None of the *in vivo* treatments (MOR or MOR CPP) resulted in a significant change in paired pulse ratio when compared to their respective controls (unpaired t-tests, SAL vs MOR, $P=0.06$; SAL CPP vs MOR CPP, $P=0.67$).

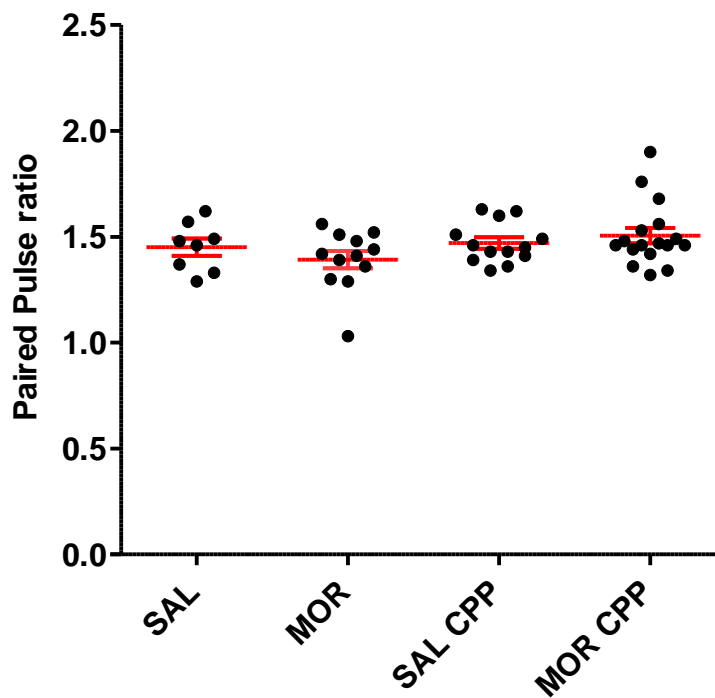

Figure 3.14 Paired-pulse facilitation following different *in vivo* treatments after stimulus-induced LTP induction.

All mice underwent in vivo treatments (non-contingent saline injections, non-contingent morphine injections, saline CPP training or morphine CPP training). After a stable baseline LTP was induced by a theta-burst. 60 minutes later, two EPSPs were evoked 50ms apart and the slopes of the ensuing fEPSPs were recorded. PPF ratio is the slope of the 2nd fEPSP divided by the slope of the 1st fEPSP. Scatter-plot shows all data points, red central line represents mean value with error bars of S.E.M. None of the in vivo treatments (MOR or MOR CPP) resulted in a significant change in paired pulse ratio when compared to their respective controls (unpaired t-tests, SAL vs MOR, $P=0.34$; SAL CPP vs MOR CPP, $P=0.48$).

3.2.7 Investigating a possible pre-synaptic component of stimulus-induced LTP

As mentioned in the introduction, there has been considerable controversy as to whether LTP at the CA3-CA1 synapse has a presynaptic component, in addition to a postsynaptic component (Nicoll and Malenka, 1999). Combining the data from Figures 3.13 and 3.14 into a single analysis allows an attempt to be made to address this issue. Looking at Figure 3.15, an obvious decreasing trend in the paired ratio is apparent 60 minutes post-LTP induction. A two-way ANOVA comparing effects of treatment and LTP induction reveals no effect of treatment but a significant ($P<0.005$) effect of LTP induction. This suggests that regardless of

treatment, LTP induction causes a decrease in paired pulse ratios when measured 60 minutes later, and so an increase in initial probability of release indicating a pre-synaptic component to this form of stimulus-induced LTP.

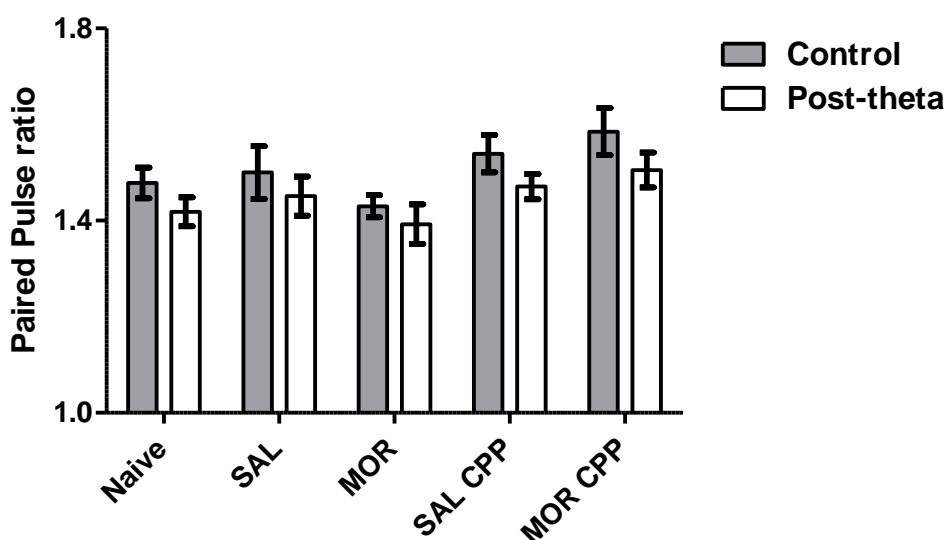

Figure 3.15 Paired-pulse facilitation before and after stimulus-induced LTP induction following different *in vivo* treatments.

All mice either underwent in vivo treatments (SAL, MOR, SAL CPP or MOR CPP), or were completely untreated ('naive'). After a stable baseline, two EPSPs were evoked 50ms apart and the slope of the ensuing fEPSPs were recorded. PPF ratio is the slope of the 2nd fEPSP divided by the slope of the 1st fEPSP. In each slice, LTP was then induced by theta-burst stimulation and paired-pulse ratio recording repeated 60 minutes later. Data are plotted as mean with error bars of S.E.M. A two-way ANOVA comparing effects of treatment and LTP induction revealed no treatment x LTP induction interaction but a significant ($P < 0.005$) effect of LTP induction.

3.3 Summary

The major findings of the fEPSP experiments were as follows

- Theta-burst stimulations in the striatum radiatum of the CA1 hippocampal area result in a significant increase in fEPSP slope values.
- This increase in fEPSP slope value is attenuated *ex vivo* by *in vivo* treatment with morphine
- Exposure to the CPP apparatus alone is sufficient to augment the increase in fEPSP slope values *ex vivo*
- Stimulus-induced increases in fEPSP slope values were associated with concurrent decreases in paired-pulse ratios. The finding that LTP induction decreases paired pulse ratios in CA1 has been shown previously (Kleschevnikov *et al.* 1997; Schulz *et al.* 1994) and adds further weight to the argument that a change in presynaptic neurotransmitter release may occur, at least during E-LTP *in vitro*.

These results present clear evidence that morphine administration, whether non-contingent or used to induce place preference did affect synaptic transmission in CA1. Another surprising finding was that exposure to the CPP apparatus alone (after only saline injections) was sufficient to augment stimulus-induced increases in fEPSP slope values. Using fEPSP recordings alone it was unclear as to whether CPP and morphine were having opposing effects on the same mechanism, or if they were acting via separate mechanisms. In fact it was unclear if morphine administration was causing this effect by inducing LTP *in vivo* (an occlusion effect) or if it was a 'metaplastic' effect. As discussed in the introduction to this chapter, there are two different possible interpretations of changes in stimulus-induced LTP, Figure 3.17 illustrates these two possible situations. As can be seen from the figure, potentiation of the AMPA response through or insertion of AMPARs into the postsynaptic membrane would be predicted to increase the relative amount of current flowing through AMPARs relative to NMDARs (Ungless *et al.* 2001). It may

therefore be possible to distinguish between these two situations through the measurement of these two currents. In order to make these measurements whole cell patch clamp can be used. This was the focus of the following chapter.

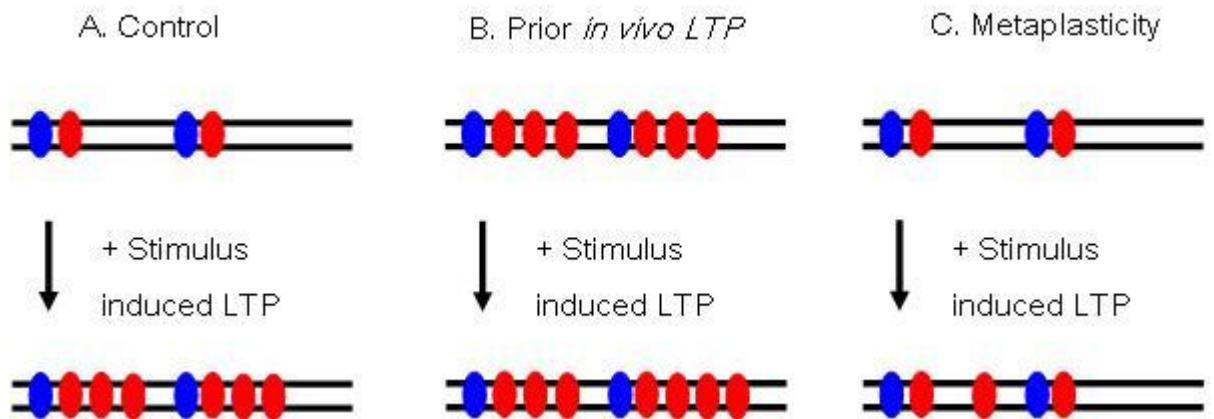

Figure 3.16 A cartoon to illustrate the two possible interpretations of a reduction in stimulus-induced LTP.

*Blue dots represent NMDARs, red dots represent AMPARs. In A, control LTP induction inserts AMPARs and so expresses normal LTP. In B, prior *in vivo* LTP prevents the induction of further LTP due to saturation of available AMPAR locations on the postsynaptic membrane. In C, metaplastic mechanisms reduce the insertion of AMPARs (and therefore the expression of LTP) through an undefined mechanism. The two situations B and C may be distinguished by measuring the relative amounts of current flow through AMPARs and NMDARs using whole cell patch clamp.*

Chapter 4: Examination of Post-Synaptic Changes in CA1 caused by Morphine and Morphine-induced Place Preference Using Whole-Cell Patch Clamp

4.1 Introduction

As mentioned above, the fEPSP data suggested a change in synaptic transmission had occurred in CA1. It was unclear what this change was however, and so whole cell patch clamp was utilised in an attempt to define a mechanism. One commonly used method of assessing *in vivo* modifications in *ex vivo* slices is the use of AMPA:NMDA values (in conjunction with a host of other measurements). While Billa *et al.* (2010a) found that non-contingent morphine had no effect on stimulus-induced LTP, they did show that AMPA:NMDA values were increased. They attributed this change to an increased insertion of GluR2 lacking AMPARs. Therefore it was important to discover if the observed effects in this study were due to changes in AMPA:NMDA and/or changes in the stoichiometry of AMPARs.

Before these experiments were undertaken, further optimisation of the CPP paradigm resulted in a two-chambered, non-biased counter balanced design. This model of CPP is desirable as it has less theoretical concerns (see Appendix) and the demonstration of place preference can be done without saline controls (Bardo and Bevins 2002). The reasons for this change are discussed in more detail in the Appendix (section A.1).

4.2 Results

4.2.1 A new model of morphine-induced conditioned place preference.

Due to the methodological concerns with the previous CPP model used in Figure 3.3 (also see appendix section A.1), an unbiased, counterbalanced protocol was developed. Again conditioned place preference was expressed as a 'score' (time in morphine paired compartment minus time in saline paired compartment) and CPP was measured as a significant increase in this score after conditioning. While this model of CPP allows for the demonstration of preference independent of saline controls, these were still included as they were required for the electrophysiological comparisons. For all of the following experiments, electrophysiology was performed immediately after the test session. This version of the CPP model may be regarded as the 'ideal' amongst CPP models as it does

not suffer from the interpretative problems of the previous model (Cunningham *et al.* 2003).

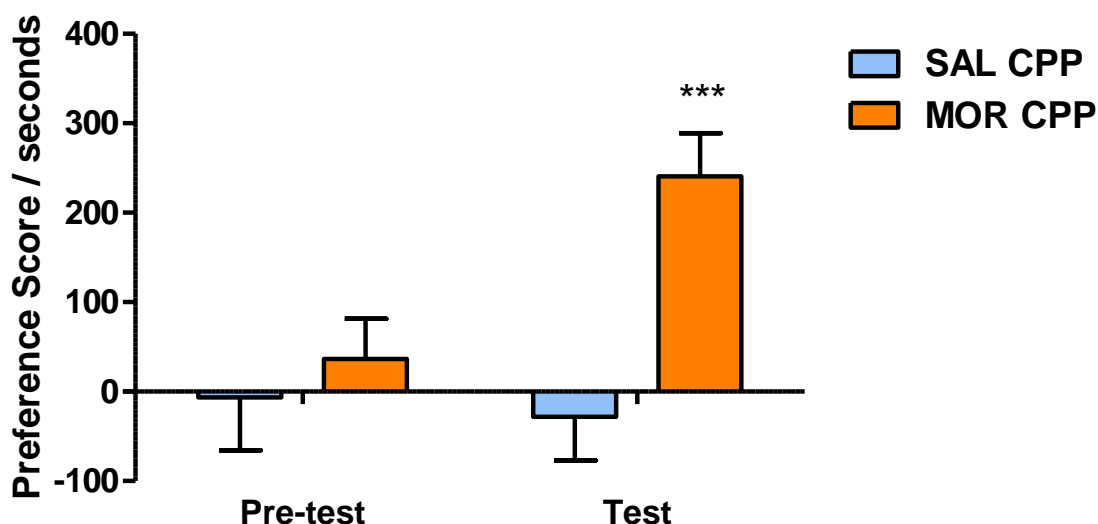

Figure 4.1 Morphine-induced conditioned place preference (CPP).

Mice were exposed to the unbiased conditioned place preference apparatus (see methods section 2.2.4). The time spent in each compartment was recorded in order to calculate a preference score (time spent in drug-paired compartment minus time spent in saline paired compartment). Mice were then assigned to one of two treatment groups (SAL CPP and MOR CPP). Following conditioned place preference training, animals were allowed free access in the CPP boxes and preference score on the test day was recorded. A two-way ANOVA comparing the effects of both conditioning and morphine treatment revealed a significant drug x conditioning interaction with no effect of conditioning but a significant effect of drug ($P < 0.005$). Bonferroni post tests revealed MOR CPP group spent significantly longer in the drug-paired compartment on the test day compared to pre-test ($P < 0.001$, $n = 14$ for both groups) but with no significant difference in the SAL CPP group..

4.2.2 AMPA:NMDA in CA1 neurones following MOR and MOR CPP treatment

The previous chapter identified changes in *ex vivo* stimulus-induced LTP from animals that had undergone different specific *in vivo* treatment regimens. Specifically, MOR treatment caused a reduction in the ability of synapses to undergo stimulus-induced LTP, whereas SAL CPP training caused a potentiation in stimulus-induced LTP (Figure 3.7). Conditioned place preference training, but not morphine treatment, also caused a significant increase in the variability of this response.

The two most likely explanations for the change in magnitude of stimulus-induced LTP is either that the *in vivo* treatment itself induces either LTP or LTD (occlusion effects) or that the *in vivo* treatments induce metaplastic changes. This could then affect the degree of stimulus-induced LTP expressed (this concept was discussed in more detail in section 3.3). As already discussed, one of the expressions of NMDAR-dependent LTP in CA1 is the insertion of AMPARs in the postsynaptic membrane. This could be predicted to increase the relative amounts of AMPAR-mediated current compared to NMDAR-mediated current. Indeed this effect has been used previously by many authors as a way of measuring prior *in vivo* LTP in *ex vivo* experiments (Ungless *et al.* 2001). When expressed as the ratio AMPA:NMDA therefore, this value can be thought of as a measure of previous potentiation of the recorded synapses.

In an attempt to reduce inter-subject variability, all animals were killed and slices taken immediately after conditioned place preference testing for MOR CPP and SAL CPP groups or 24 hours after the last injection for SAL and MOR groups.

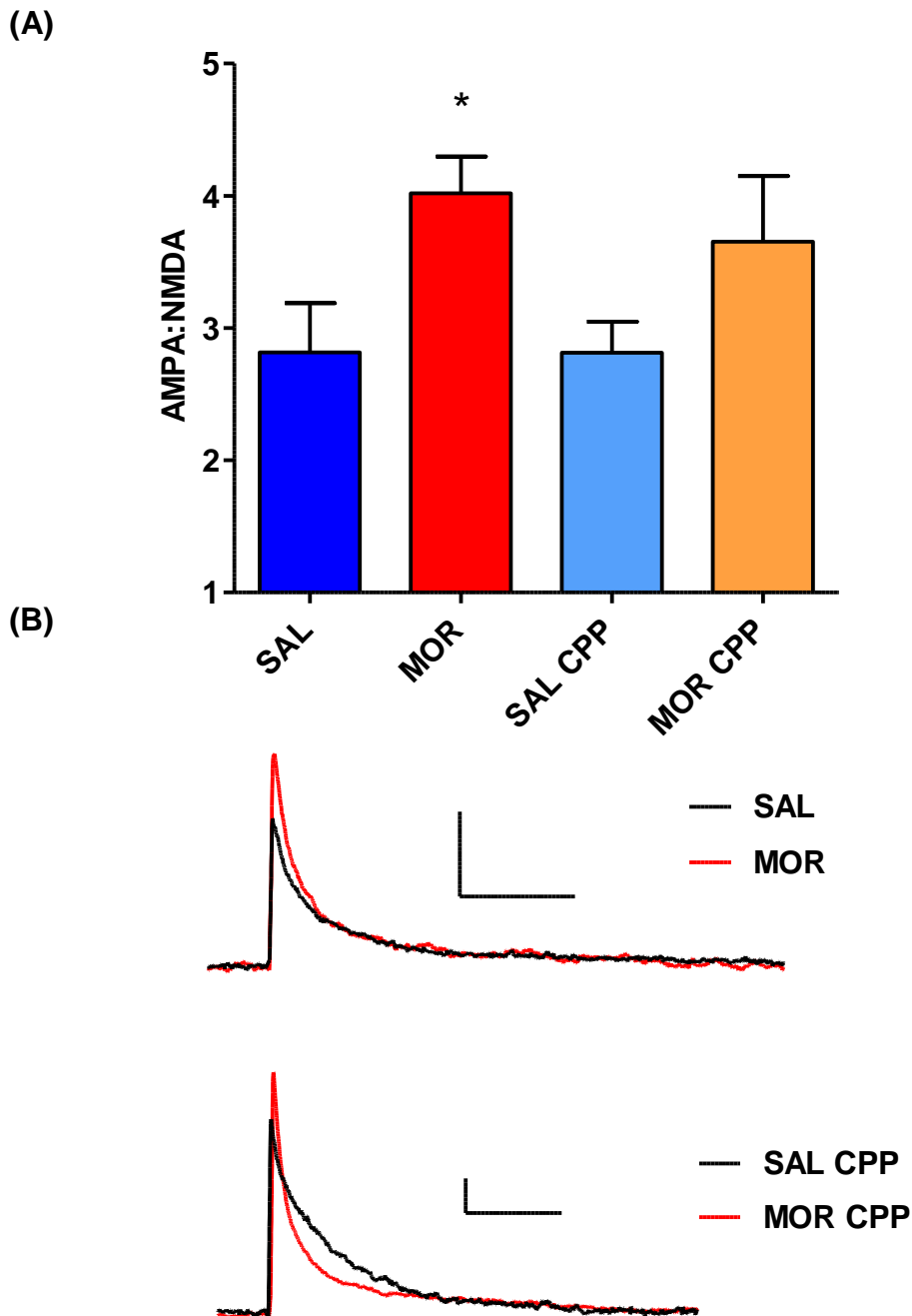

Figure 4.2 AMPA:NMDA at CA3-CA1 synapses after contingent and non-contingent morphine and saline treatments.

(A) All mice underwent *in vivo* treatments (SAL, MOR, SAL CPP or MOR CPP). Under voltage-clamp at +40mV, EPSCs were evoked and the AMPA and NMDA components measured as described in the Appendix. The ratio AMPA:NMDA is the magnitude of the AMPA component divided by the magnitude of the NMDA component, in each recorded neurone. While AMPA:NMDA was increased in MOR ($n = 9$ from 5 mice) compared to SAL ($n=11$ from 6 mice, $P<0.05$, unpaired *t*-test). Comparing MOR CPP to SAL CPP was hindered due to the large increase in variance in the MOR CPP ($n=21$ from 11 mice) compared to SAL CPP ($n=16$ from 9 mice, F -test value=0.001, $P=0.14$ unpaired *t*-test with Welch's correction). **(B)** Representative traces showing single measurements of AMPA:NMDA in each test group. Calibration bars are 100ms and 100pA.

Figure 4.2 shows that there was a significant increase in the AMPA:NMDA in animals that had undergone MOR treatments, compared to those that had undergone SAL treatments. This suggests that the decrease in magnitude in stimulus-induced LTP (see Chapter 3) could be because the *in vivo* morphine treatment has itself induced a form of LTP at these synapses. There was a similar but non-significant trend in the MOR CPP group compared to SAL CPP group, see Figure 4.2(A).

The situation appears to be different concerning the augmentation of stimulus-induced-LTP in the CPP groups. There were no obvious differences between the AMPA:NMDA for SAL and SAL CPP groups, this suggests that the increase in stimulus-induced-LTP seen after CPP training may not have been due to an occlusion effect. The observed changes in the CPP groups as seen in Chapter 3 is therefore more likely to be due to changes in metaplasticity.

By showing AMPA:NMDA data as a scatter plot with means and standard deviations (rather than means and S.E.M.s) the increase in variability in the MOR CPP group is highlighted. The F-test can be used to compare variability of two samples, and showed that the MOR CPP data is significantly more variable than the data in each of the other treatment groups ($P = 0.04$ vs SAL; $P = 0.006$ vs. MOR; $P = 0.011$ vs. SAL CPP). Using Grubb's test, there are no statistically-significant outliers in any of the samples. It is worth noting that this change in variability seen in MOR CPP was not seen in SAL CPP as was the case in the fEPSP recordings. This result suggests that these two effects may not be related.

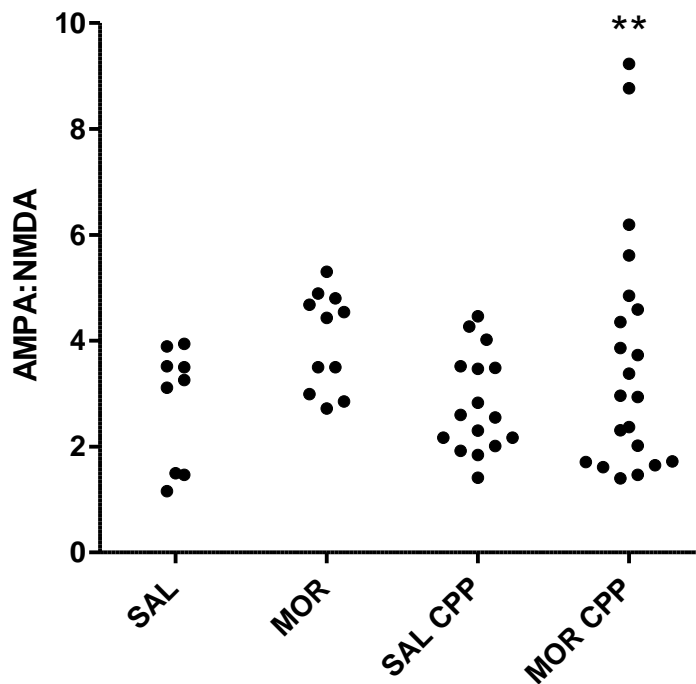

Figure 4.3 Variability of AMPA:NMDA at CA3-CA1 synapses.

All mice underwent *in vivo* treatments; SAL, MOR, SAL CPP or MOR CPP. Under voltage-clamp at +40mV, EPSCs were evoked and the AMPA and NMDA components recorded. AMPA:NMDA is the magnitude of the AMPA component divided by the magnitude of the NMDA component in each recorded neurone. Scatter plot shows all data ($n = 9 - 21$). ** = $P < 0.01$; F-test for equal variance (MOR CPP vs SAL CPP).

4.2.2 Investigating whether AMPA:NMDA is correlated with magnitude of expression of conditioned place preference learning

In an attempt to uncover the reason for this significantly increased variability, a correlation was again sought between the degree of conditioned place preference behaviour seen *in vivo* with the AMPA:NMDA value measured *ex vivo*. No significant correlation, nor deviation of the line of best-fit from zero, was observed (Figure 4.4). In Chapter 3, a possible interaction between the time between end of *in vivo* treatment and preparation of slices was investigated (but not found - Figure 3.11). There can be no possible correlation in these data, as all slices were taken 1 day following the final injection (or immediately after CPP test), to minimise this potential confounding variable.

Figure 4.3 does clearly show that there is an increase in variability in AMPA:NMDA in the morphine CPP group, but this is not correlated with the level of expression of conditioned place preference behaviour in animals from which slices were subsequently taken (Figure 4.4). Therefore, the increase in variability might be due to neurone-specific changes induced by morphine conditioned place preference. For example, it might be that only in a subset of neurones are LTP-like changes induced by morphine conditioned place preference training. Therefore, the next step was to search for correlations between different cell parameters that could identify subsets of CA1 hippocampal neurones that are affected differently by MOR CPP treatment.

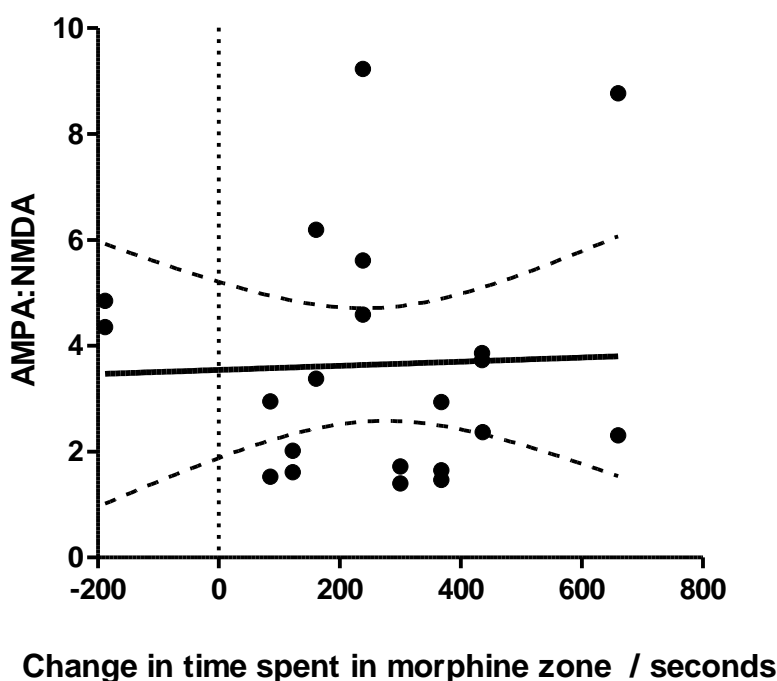

Figure 4.4 Correlation plot of conditioned place preference behaviour and AMPA:NMDA.

All mice are from MOR CPP group. Degree of expressed conditioned place preference behaviour is plotted on the x axis (the difference in time spent in the morphine-conditioned side on the post-training day minus time spent in the morphine-conditioned side on the pre-training day in seconds). Y axis shows AMPA:NMDA in a slice taken from that animal. Linear regression analysis was then performed, solid line is line of best-fit, dashed lines are 95% confidence band of regression line. There was no significant correlation between magnitude of expression of CPP behaviour and magnitude of AMPA:NMDA ratio. $R^2 = 0.001$, $P = 0.87$ for statistical deviance of line-of-best-fit from zero.

4.2.3 Investigating possible subsets of CA1 neurones – relationship to AMPA:NMDA following MOR CPP training

First of all the stimulus intensity that resulted in 75% of the maximum evoked EPSC was analysed. Figure 4.5 shows that there was no overall change in this value (effectively an input/output measure) between any of the *in vivo* treatment groups. Data are shown as stimulus intensity required to elicit 75% of the maximum EPSC. Unpaired t-tests failed to find any significant differences between any of the groups. Likewise F-tests did not detect any differences in the variability of the data between treatment groups.

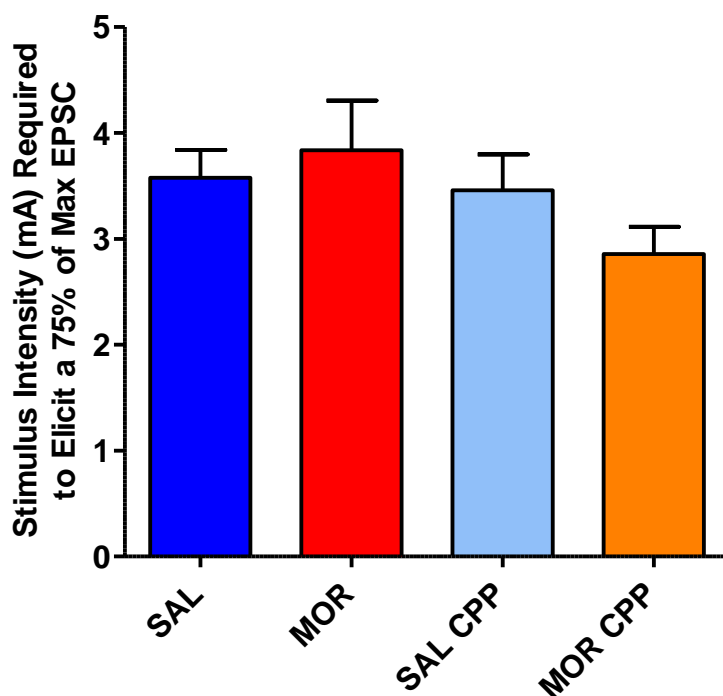

Figure 4.5 Stimulus intensity required to elicit 75% of max EPSC.

All mice underwent in vivo treatments; SAL, MOR, SAL CPP or MOR CPP. Input-Output relationships were studied by changing stimulation intensity and recording evoked EPSC amplitude. Stimulation intensity required to evoke 75% maximum EPSC response was recorded and plotted. Data shown are mean \pm S.E.M. Unpaired t-tests failed to find any significant difference between any of the groups $n = 9-12$.

Figure 4.6 also shows that there is no significant correlation, nor deviance of the line of best-fit from zero, when correlating stimulus intensity with AMPA:NMDA in the MOR CPP group. These data suggest that there is no sub-set of neurones that can be identified on the basis of stimulation intensity required to evoke 75% maximum EPSC (effectively an input/output measure). Also, the increase in variability of AMPA:NMDA in the morphine CPP treatment group is not by virtue of an artefact of these recordings being stimulated at more varied stimulation intensities compared with the other groups

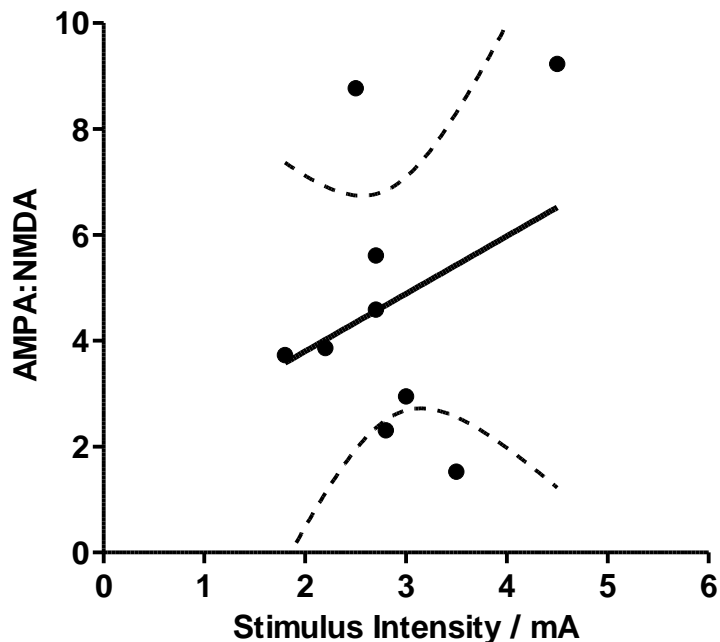

Figure 4.6 Correlation plot of stimulation intensity and AMPA:NMDA in slices taken from mice that underwent MOR CPP treatment.

All mice underwent morphine-induced conditioned place preference training. Stimulation intensity required to evoke EPSC at 75% maximum response is plotted on the x axis. Y axis shows data plotted as AMPA:NMDA in the same slice. Linear regression analysis was then performed; solid line is line of best-fit, dashed lines are 95% confidence band of regression line. There was no significant correlation between stimulation intensity applied and magnitude of AMPA:NMDA. $R^2 = 0.1$, $P = 0.41$ for statistical deviance of line-of-best-fit from zero.

There were, however, changes observed in whole-cell capacitance between different treatment groups. Figure 4.7 demonstrates this, and shows that the whole-cell capacitance is significantly higher in the non-contingent morphine group, compared with saline, but not in the morphine CPP or saline CPP groups. There were no significant changes in the variability of capacitance measurements between treatment groups (F-test).

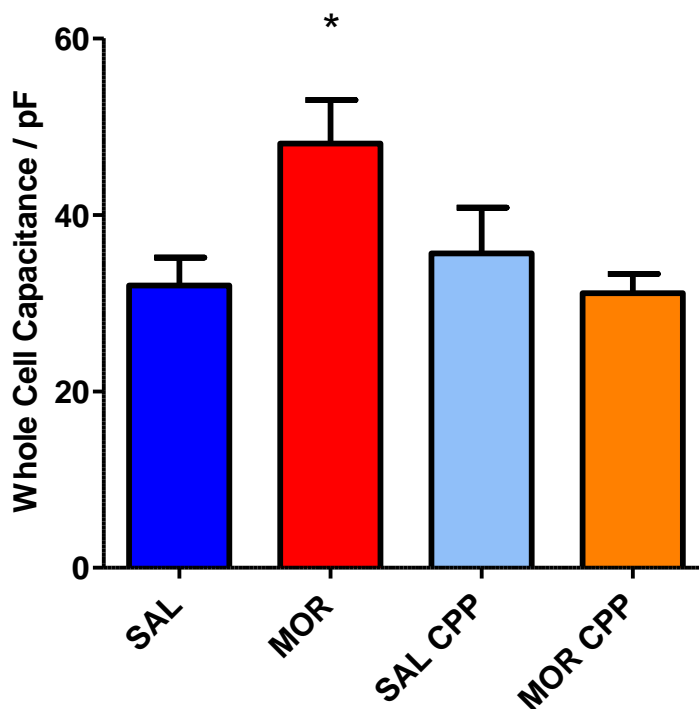

Figure 4.7 Whole-cell capacitance.

All mice underwent in vivo treatments; SAL, MOR, SAL CPP or MOR CPP. Whole-cell capacitance was measured during voltage-clamp recordings from CA1 neurones. Data shown are mean \pm S.E.M. $n = 9-21$. Unpaired t -test revealed MOR group had significantly increased whole cell capacitance compared to both SAL ($P < 0.05$).

Figure 4.8 shows that there is no significant correlation, nor deviance of the line of best-fit from zero, when correlating stimulus intensity with AMPA:NMDA in the MOR CPP group. There was no correlation between whole cell capacitance and AMPA:NMDA in the MOR group also.

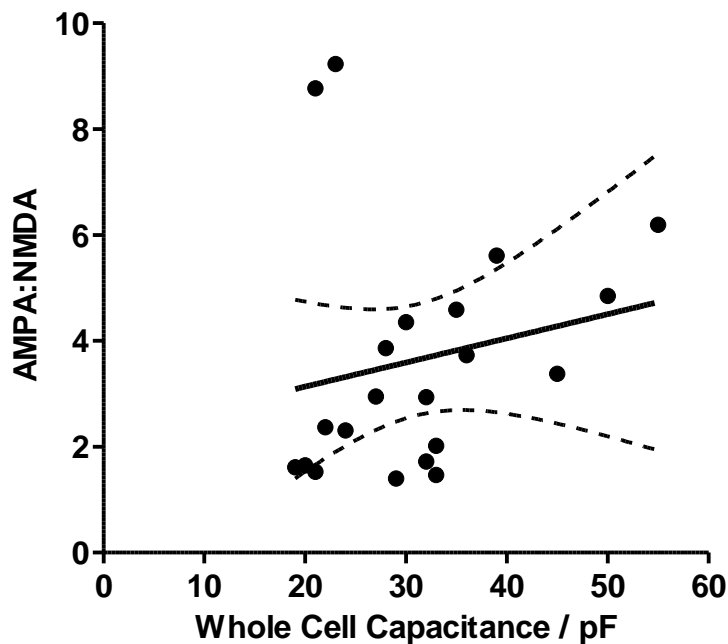
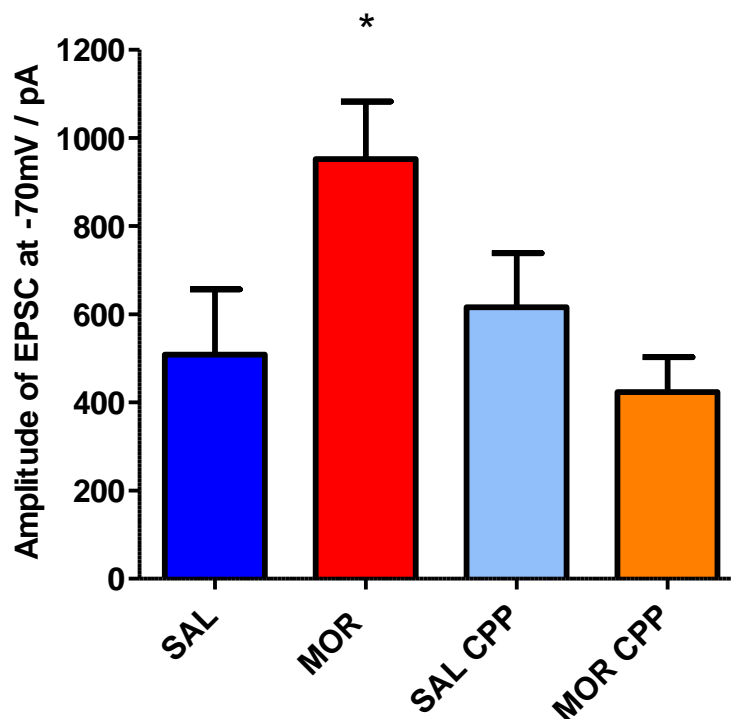

Figure 4.8 Correlation plot of whole-cell capacitance and AMPA:NMDA in slices taken from mice that underwent MOR CPP treatment.

All mice underwent morphine-induced conditioned place preference training. Whole-cell capacitance (pF) is plotted on the x axis. Y axis shows data plotted as AMPA:NMDA in the same cell. Linear regression analysis was then performed; solid line is line of best-fit, dashed lines are 95% confidence band of regression line. There was no significant correlation between whole-cell capacitance and magnitude of AMPA:NMDA ratio. $R^2 = 0.04$, $P = 0.39$ for statistical deviance of line-of-best-fit from zero.

Similarly, the magnitude of the EPSC itself was significantly higher in the non-contingent morphine-treated group (Figure 4.9).

(A)



(B)

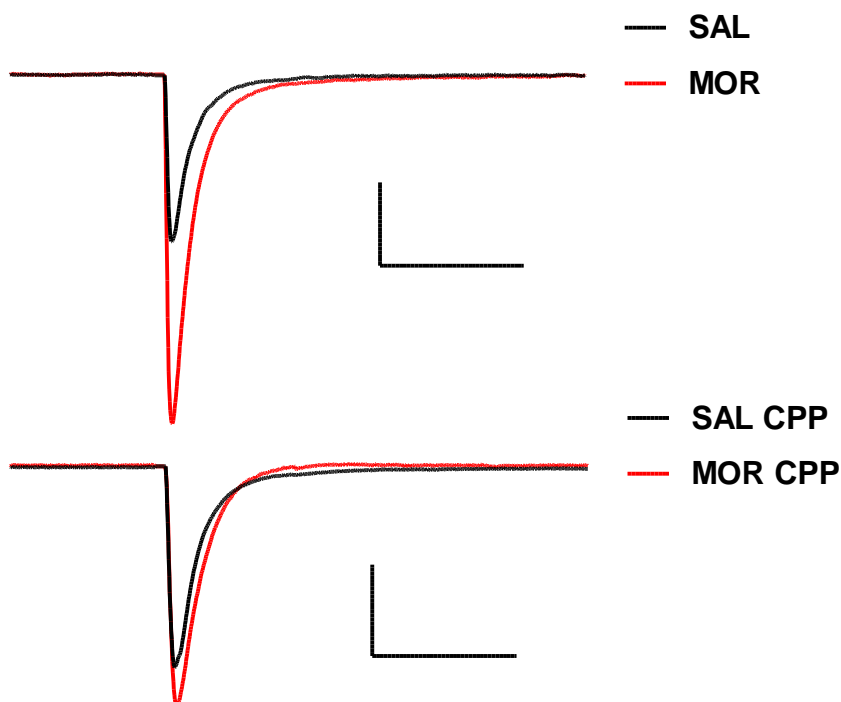

Figure 4.9 Magnitude of evoked EPSC.

(A) All mice underwent *in vivo* treatments; SAL, MOR, SAL CPP or MOR CPP. EPSCs were evoked at 75% of max and amplitude recorded during voltage-clamp at -70mV. Data shown are mean \pm S.E.M. SAL n=9 from 6 mice, MOR n=11 from 6 mice, SAL CPP n=10 from 5 mice, MOR CPP n=21 from 11 mice. * = $P < 0.05$; *t*-test vs. SAL. (B) Representative traces for each of the test groups, calibration bars set to 50ms and 250pA.

Figure 4.9 shows that in neurones recorded from animals that had MOR treatment, there was a significant increase in the magnitude of evoked EPSC. This was parallel to the increase in whole-cell capacitance already shown (Figure 4.7). Although there was no change in this measure in neurones taken from slices in the MOR CPP group a correlation between this parameter and AMPA:NMDA for MOR CPP was still drawn. Figure 4.10 shows that there is no relationship however.

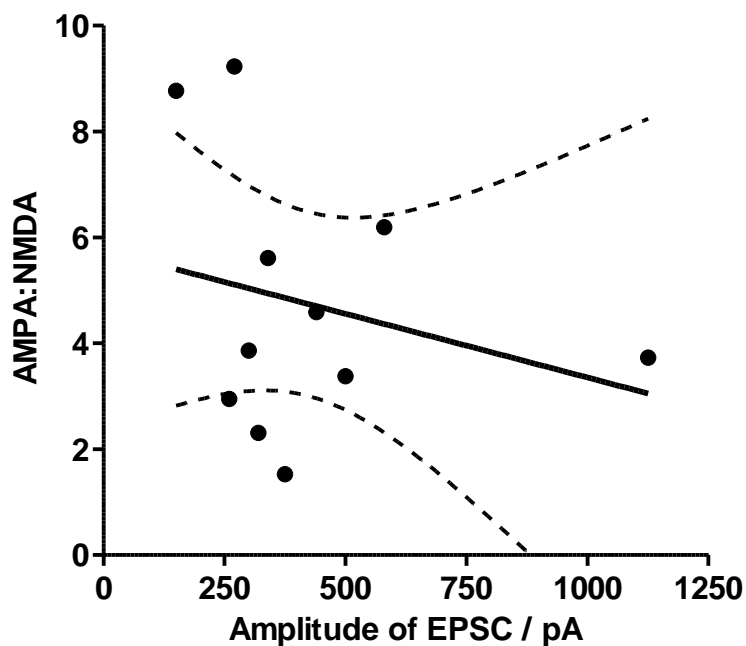

Figure 4.10 Correlation plot of 75% of max EPSC amplitude and AMPA:NMDA in slices taken from mice that underwent MOR CPP treatment.

All mice underwent morphine-induced conditioned place preference training. EPSC amplitude (pA) is plotted on the x axis. Y axis shows AMPA:NMDA in the same neurone. Linear regression analysis was then performed; solid line is line of best-fit, dashed lines are 95% confidence band of regression line. There was no significant correlation between EPSC amplitude and magnitude of AMPA:NMDA. $R^2 = 0.06$, $P = 0.46$ for statistical deviance of line-of-best-fit from zero.

4.2.4 Investigating the change in EPSC amplitude after non-contingent MOR treatment

EPSC amplitude was surprisingly increased in non-contingent MOR treated animals but not in the MOR CPP treated animals (Figure 4.9). EPSC amplitude when voltage clamped at -70mV is a general measure of the total number of AMPARs being stimulated (or the sensitivity of the AMPARs in question). Therefore one might suggest that if an increase in AMPA:NMDA was due to the insertion of AMPARs (or an increase in their sensitivity), then the EPSC amplitude would also increase. There was however, no apparent correlation between the EPSC amplitude and AMPA:NMDA in individual neurones for MOR treated group ($R^2=0.06$, $P=0.43$, graph not shown). This suggests that the increase in EPSC amplitude and the increase in AMPA:NMDA may occur via different mechanisms (possibly a pre-synaptic mechanism).

An increase in EPSC amplitude could be caused by an increase in the total number of synapses being stimulated. A larger cell with more synapses would have a larger surface area and therefore an increased whole cell capacitance. Indeed, whole cell capacitance, generally seen as an indicator of neuronal cell size, was positively correlated with EPSC amplitude when all treatment groups were pooled together ($R^2=0.25$, $P=0.001$, graph not shown). Whole cell capacitance was also increased in the MOR treatment group compared to saline (Figure 4.7) and when EPSC amplitude is corrected for by cell capacitance there is no longer a significant difference between EPSC amplitudes across treatment groups (Figure 4.11). This suggests that the increase in EPSC amplitude in MOR treated animals may be due to an increase in the number of synapses.

To summarise these findings, EPSC amplitudes and cell size appeared to be increased after MOR treatment, but not MOR CPP treatment. EPSC amplitudes depend on both pre- and postsynaptic mechanisms and therefore interpreting the results is difficult. The whole cell capacitance data however suggests that the locus of change at least involves a postsynaptic component. No evidence was found for a relationship between AMPA:NMDA and EPSC amplitudes.

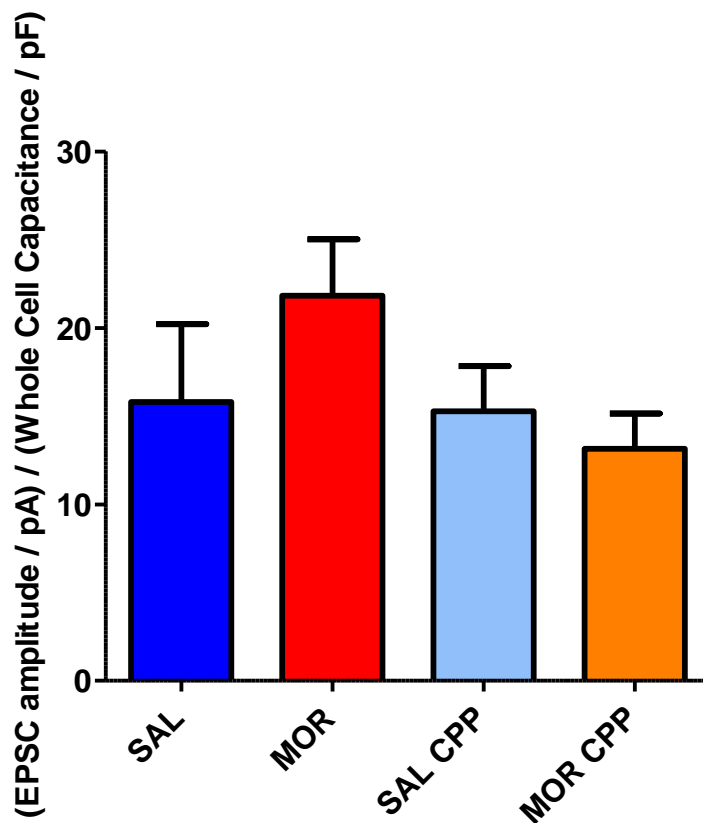

Figure 4.11 Magnitude of evoked EPSC normalised to whole-cell capacitance.

All mice underwent in vivo treatments; SAL, MOR, SAL CPP or MOR CPP. EPSCs were evoked, whole-cell capacitance (pF) and 75% of max EPSC amplitude (pA) were measured. For each recorded neuron, 75% of max EPSC amplitude was then divided by whole-cell capacitance value (pA/pF). Data shown are mean \pm S.E.M. n = 9-11.

4.2.5 Investigating the relationship between AMPA:NMDA and holding current

The final cellular parameter that was measured was the holding current at -70mV. Here, there was no overall change in average holding potential between treatment groups (Figure 4.12). Although there was no apparent change between the different treatment groups, there was a significant positive correlation between holding current and AMPA:NMDA in the MOR CPP group (Figure 4.13).

The initial purpose of investigating these correlations was to ascertain whether there was a correlation between a certain cellular parameter and AMPA:NMDA in the MOR CPP group of animals that might explain the significant increase in variability of AMPA:NMDA seen in that treatment group. Figure 4.13 suggests that the holding current of a neurone is a predictor of whether an individual neurone displays high or low AMPA:NMDA following MOR CPP treatment. However, for this to explain the increase in overall variability of AMPA:NMDA in the MOR CPP group, this correlation would have to be specific to that treatment group, not to the other treatment groups.

Figure 4.14 shows a correlation plot between AMPA:NMDA and holding current for each cell from each treatment group (SAL, MOR, SAL CPP and MOR CPP) collated together. As with the MOR CPP group alone, there is a relatively weak overall correlation ($r^2 = 0.16$), but there is a highly significant deviation of the line of best-fit away from zero ($P = 0.003$).

Therefore, although there appears to be a correlation between holding current and AMPA:NMDA, this is not specific to the MOR CPP group but a general property of these neurones.

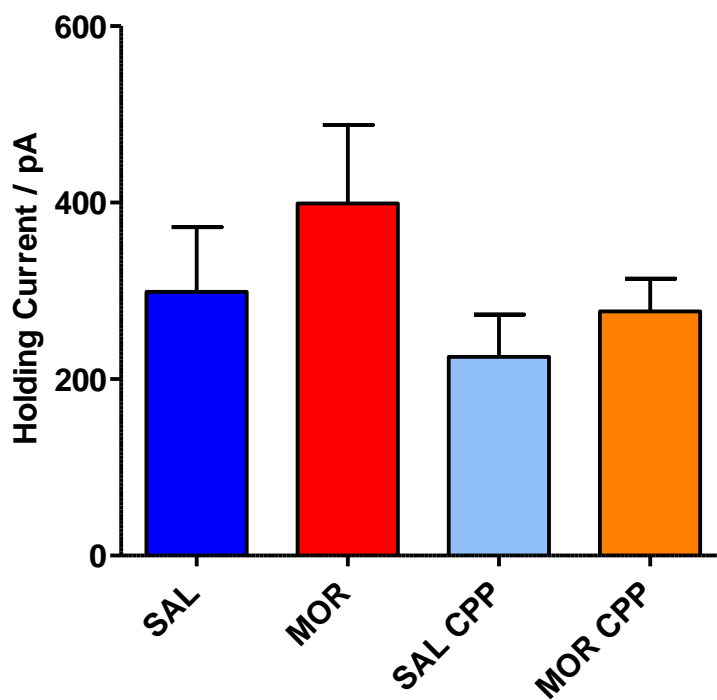

Figure 4.12 Holding current at -70mV across treatment groups.

All mice underwent in vivo treatments; SAL, MOR, SAL CPP or MOR CPP. Neurones were voltage-clamped at -70mV and the holding current measured. Data shown are mean \pm S.E.M. n = 9-21. Unpaired t-tests failed to find any significant differences between the groups.

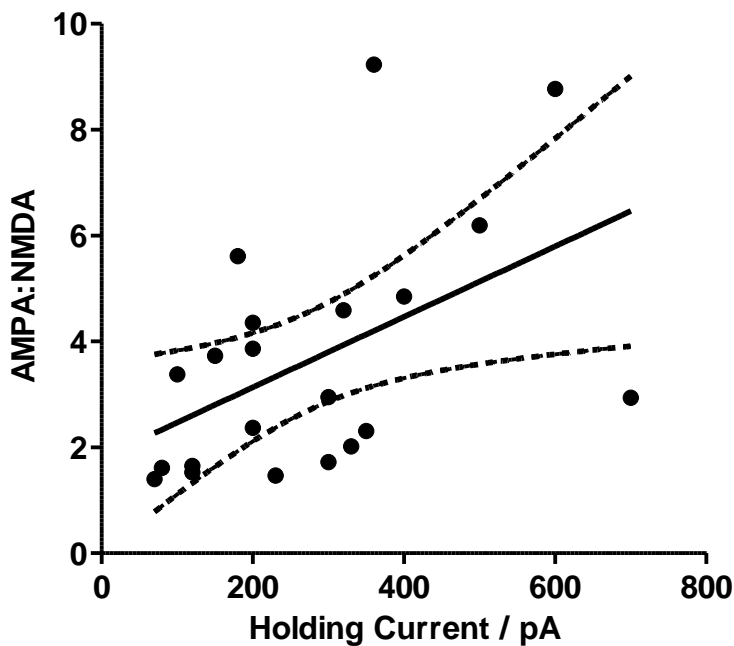

Figure 4.13 Correlation plot of holding current at -70mV and AMPA:NMDA in slices taken from mice that underwent MOR CPP treatment.

All mice underwent morphine-induced conditioned place preference training. Holding current (pA) is plotted on the x axis. Y axis shows data plotted as AMPA:NMDA in the same neurone. Linear regression analysis was then performed; solid line is line of best-fit, dashed lines are 95% confidence band of regression line. There was a significant deviance of the line of best-fit from zero, showing that there is a correlation between holding current and AMPA:NMDA. $R^2 = 0.24$, $P = 0.02$ for statistical deviance of line-of-best-fit from zero.

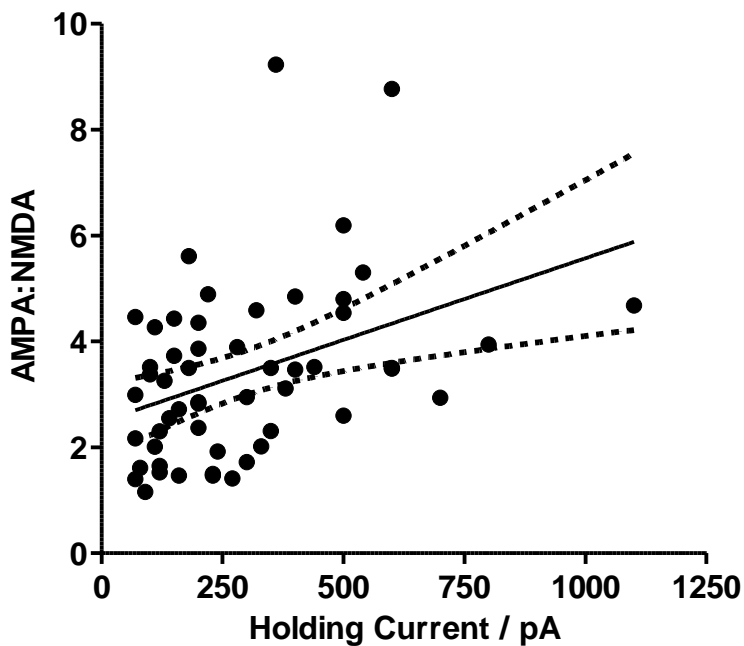

Figure 4.14 Correlation plot of holding current at -70mV and AMPA:NMDA.

All mice underwent SAL, MOR, SAL CPP or MOR CPP treatment. Neurones were voltage-clamped at -70mV and holding current and AMPA:NMDA of evoked EPSCs recorded. Holding current (pA) is plotted on the x-axis. Y axis shows data plotted as AMPA:NMDA in the same neurone. Linear regression analysis was then performed; solid line is line of best-fit, dashed lines are 95% confidence band of regression line. There was a weak but significant deviance of the line of best-fit from zero, showing that there is a correlation between holding current and AMPA:NMDA. $R^2 = 0.16$, $P = 0.003$ for statistical deviance of line-of-best-fit from zero.

4.2.6 Investigating the mechanism by which holding current and AMPA:NMDA are correlated

The observation that there is a general correlation between holding current and AMPA:NMDA is interesting and has not been previously described. The potential explanation for this was explored further. There are two possible reasons for why the holding current might change from neurone to neurone. One is that the resting membrane potential might be different, and the other is that the input resistance might be different, as the holding current is formed by a combination of how far away from the resting membrane potential the neurone is voltage-clamped at, as well as the input resistance of that neurone. Although the resting membrane potential and input resistances were not empirically measured in these experiments, during the recordings, a further holding current was measured when the cell was voltage-clamped at +40mV. If the predominant reason for a change in holding current from neurone to neurone was because of input resistance rather than a change in resting membrane potential, then there would be a strong correlation between holding current at -70mV and holding current at +40mV. This was indeed the case (see Figure 4.15).

An increase in input resistance is often seen as an indicator of neuronal size, where smaller neurones have higher input resistance. This could also be reflected in another indicator of neuronal size: whole-cell capacitance. In other words, if the holding potential of the neurone at -70mV is more negative because it is a cell with lower input resistance, rather than because it is a cell with a less negative resting membrane potential, then there should be a correlation between holding current and whole-cell capacitance, which there is, as seen in Figure 4.16. Although the deviation of the line of best fit from zero is highly significant ($P < 0.01$), the correlation was between holding current and whole-cell capacitance was quite weak ($R^2=0.12$), suggesting that other mechanisms may also be responsible for changes in holding current.

Therefore, although there is no indication of a neuronal marker that might explain the high variability seen in the AMPA:NMDA in the MOR CPP group, it appears that the AMPA:NMDA is correlated with input resistance, potentially meaning that larger cells, or perhaps those with more complex dendritic arborisations tend to

have higher AMPA:NMDA (Andrasfalvy & Magee (2001). Another explanation and one that could potentially fit the cell capacitance data better, is that the high AMPA:NDMA expressing cells in the MOR CPP group could show an increased number of conductances at the resting membrane potential. The potential implications of these mechanisms are discussed in more detail at the end of this chapter and in Chapter 6.

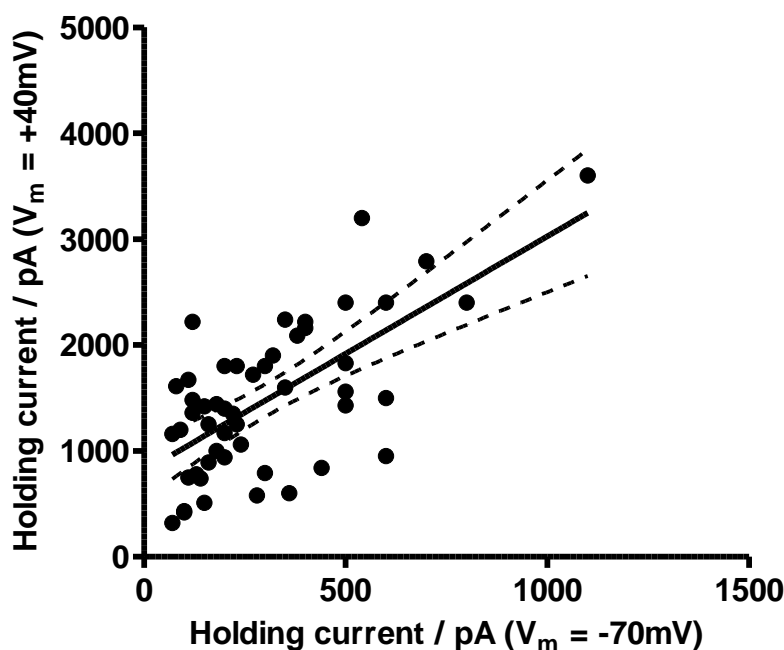

Figure 4.15 Correlation plot of holding current at -70mV and holding current at +40mV.

All mice underwent SAL, MOR, SAL CPP or MOR CPP treatment. Neurones were voltage-clamped and holding current at both -70mV and +40mV recorded. Holding current at -70mV (pA) is plotted on the x axis. Y axis shows holding current at +40mV (pA). Linear regression analysis was then performed; solid line is line of best-fit, dashed lines are 95% confidence band of regression line. There was a significant deviance of the line of best-fit from zero, showing that there is a correlation between holding current at -70mV and holding current at +40mV. $R^2 = 0.44$, $P < 0.0001$ for statistical deviance of line-of-best-fit from zero. $V_m =$ membrane potential

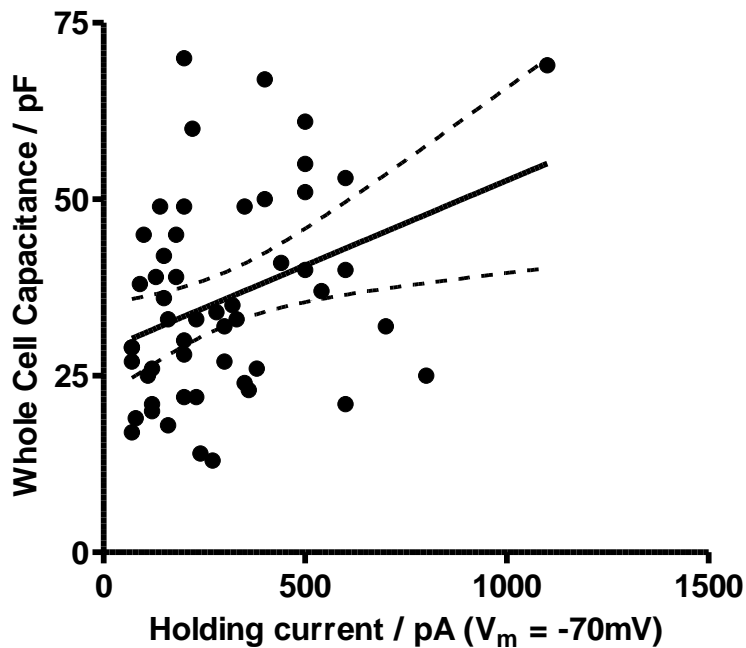

Figure 4.16 Correlation plot of holding current at -70mV and whole-cell capacitance.

All mice underwent SAL, MOR, SAL CPP or MOR CPP treatment. Neurones were voltage-clamped at -70mV and then holding current and whole-cell capacitance recorded. Holding current at -70mV (pA) is plotted on the x axis. Y axis shows whole-cell capacitance (pF) in the same neurone. Linear regression analysis was then performed; solid line is line of best-fit, dashed lines are 95% confidence band of regression line. There was a significant deviance of the line of best-fit from zero, showing that there is a correlation between holding current and whole-cell capacitance. $R^2 = 0.12$, $P = 0.009$ for statistical deviance of line-of-best-fit from zero.

4.2.7 Investigating the surface expression and subunit composition of AMPA receptors following *in vivo* treatments

At the start of this section (4.2) changes in AMPA:NMDA between MOR and SAL and between MOR CPP and SAL CPP were demonstrated. That the fact that little variation in synaptic NMDAR content is observed in CA1 neurones (Racca *et al.* 2000) means that it is often assumed that such changes are an indication that AMPAR number or function are increased. If an increase in AMPA:NMDA was purely due to an increase in postsynaptic AMPA receptors, then perhaps the response to bath-applied AMPA could be expected to be increased. This was examined in Figure 4.17. Here, slices were prepared from animals that received *in vivo* treatments as before, and 1 μ M AMPA was bath-applied for 30 seconds in the presence of 100 μ M cyclothiazide (to inhibit rapid desensitization of AMPA receptors (Fucile *et al.* 2006)). There was no significant difference in AMPA-induced current at 30 seconds (Figure 4.17).

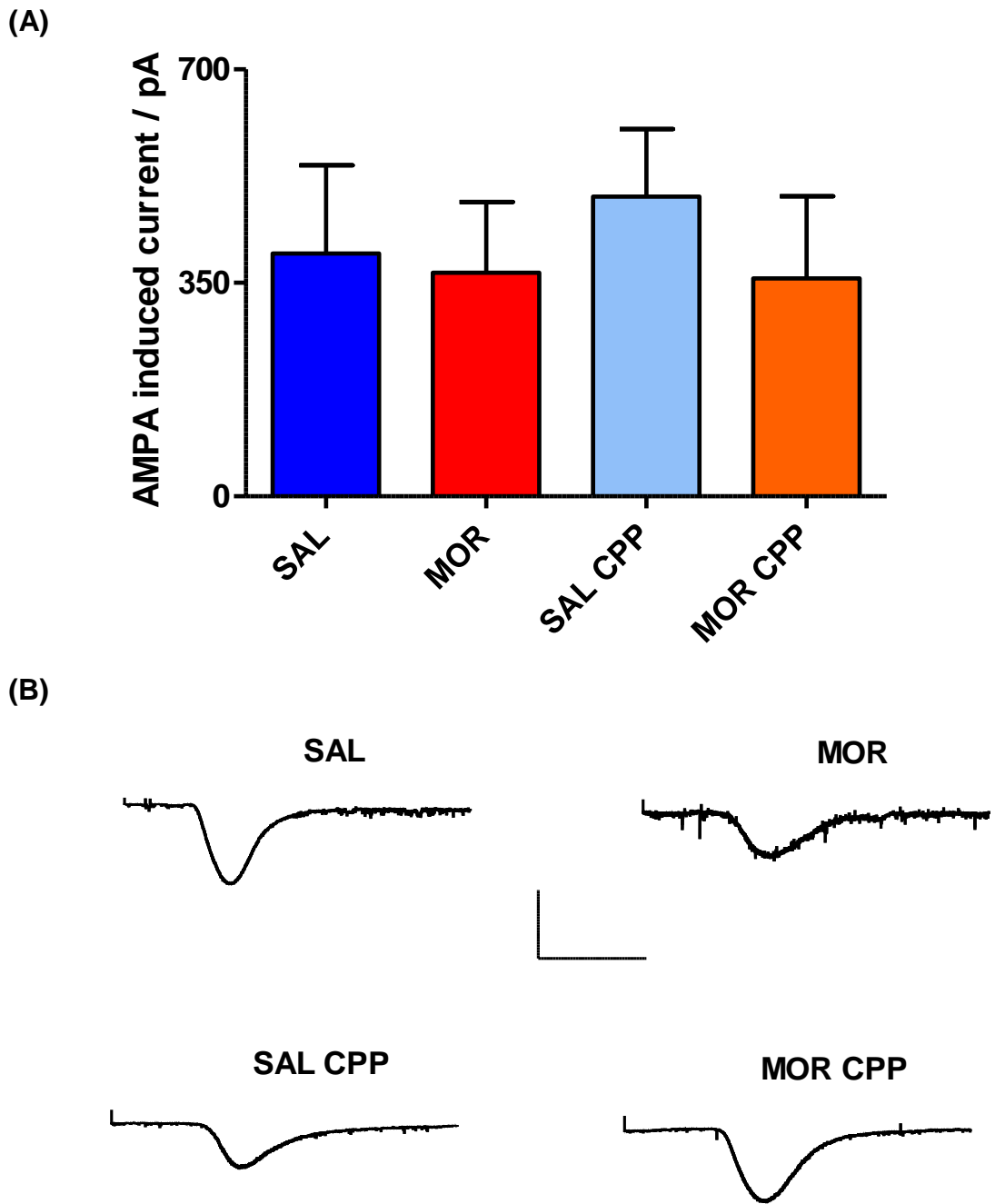

Figure 4.17 Effects of bath-applied AMPA following contingent and non-contingent *in vivo* morphine treatments.

(A) All mice underwent *in vivo* treatments; SAL, MOR, SAL CPP or MOR CPP. Neurones were voltage-clamped at -70mV and AMPA ($1\ \mu\text{M}$) in the presence of cyclothiazide ($100\ \mu\text{M}$) was washed over the slice for 30 seconds. Data shown are mean \pm S.E.M. SAL $n=6$ from 3 mice, MOR $n=6$ from 4 mice, SAL CPP $n=5$ from 3 mice, MOR CPP $n=4$ from 3 mice. (B) Representative traces for each test group showing the effects of 30 seconds of bath applied AMPA and subsequent washout. Calibration bars set to 100s and 500pA.

These data perhaps suggest that the alteration in AMPA:NMDA seen following *in vivo* morphine treatment (Figure 4.2) may not be due to induction of LTP at these synapses. These experiments are far from conclusive however, particularly because the variability in the bath-applied AMPA data was very high. Furthermore, bath-applied AMPA is far more likely to activate extra-synaptic AMPARs compared to evoked EPSCs. Thus, in these bath-applied experiments non-synaptic AMPARs could produce most of the observed current. If this was the case then any changes in synaptic AMPA current could be masked by the relatively large non-synaptic current.

A number of studies have demonstrated that LTP induction in the CA1 region (and other brain regions) occurs coincidentally with changes in the subunit composition of synaptic AMPARs as well as an overall increase in postsynaptic AMPAR density (Malenka and Bear, 2004). Specifically, LTP has been suggested to occur through the insertion of GluR2-lacking receptors. GluR2-containing and GluR2-lacking AMPA receptors have different electrophysiological characteristics that can often be measured by a change in rectification of the current flowing through the open channel (as has already been observed in the dorsal hippocampus after morphine treatment, see Billa *et al.* 2010). However, in order to observe rectification of these channels, spermine needs to be present in the patch solution. This was unfortunately not possible with a fluoride-containing pipette solution (see Appendix). Therefore, we used the selective GluR2-lacking AMPA receptor antagonist, Joro Spider toxin (JSTx, 500 nM) to assess whether it inhibited evoked EPSCs in neurones taken from animals that had received different *in vivo* treatments (Figure 4.18). No evidence of GluR2 lacking AMPARs was found.

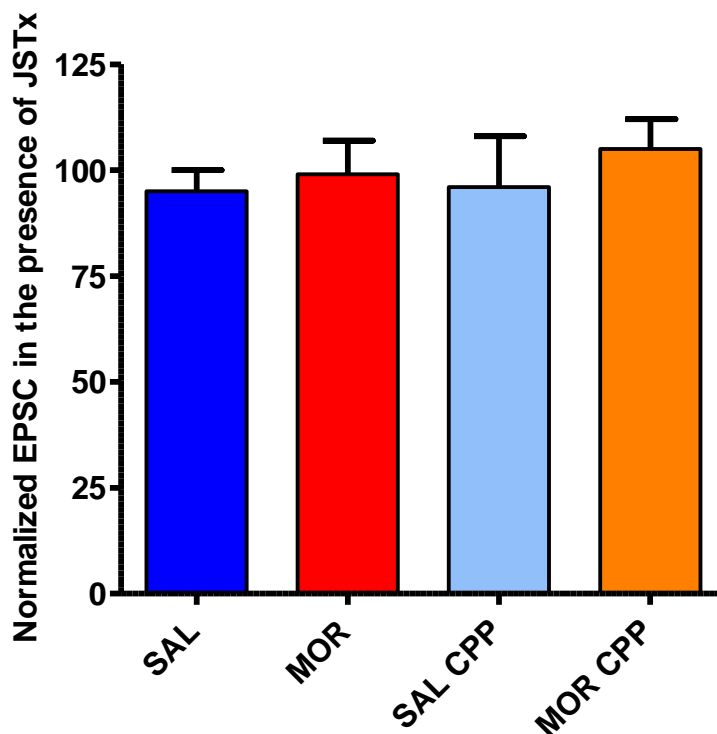

Figure 4.18 Effect of Joro Spider Toxin (JSTx) on evoked EPSCs following *in vivo* treatments.

All mice underwent in vivo treatments; SAL, MOR, SAL CPP or MOR CPP. Evoked EPSCs were recorded and inhibition by bath-applied JSTx (500 nM for 10min) was measured. Data normalised to EPSC amplitude immediately prior to JSTx application. Data shown are mean ± S.E.M. n = 3 from 3 mice for each group.

4.3 Summary

In this chapter evidence is presented that AMPA:NMDA in MOR treated animals is increased compared to SAL treated animals. In MOR CPP treated animals there was no overall increase in AMPA:NMDA observed (unlike in the non-contingent MOR group). There was however, a highly significant increase in the variability of the AMPA:NMDA measure in the MOR CPP group (F-test $P = 0.001$ vs SAL CPP group). This finding suggests that the effects of MOR CPP on AMPA:NMDA may be neuron-specific, implicating different effects on different neuronal subsets. Further discussion on this possibility is explored in the General Discussion (section 6). Efforts were made to examine whether such subsets of neurones could be identified by general electrophysiological parameters (eg. whole-cell capacitance, input resistance) but none was found.

Irrespective of *in vivo* treatment, increased AMPA:NMDA values did appear to occur alongside decreases in input resistance (input resistance is dependent on both cell size and membrane conductivity at -70mV). Recordings of whole cell capacitance suggest that cell size is not correlated to AMPA:NMDA (Figure 4.8) and therefore changes in membrane conductivity at -70mV may underlie this correlation. Further support for this idea comes from the fact that holding currents at -70mV were correlated to AMPA:NMDA values (Figure 4.14) but were not correlated at +40mV ($R^2=0.008$, $P=0.96$). While this is an interesting general observation, it did not appear to be a specific mechanism for any changes observed in the MOR CPP group, and so did not help elucidate the mechanism involved in the increased variability in AMPA:NMDA values for this group.

In contrast to what was found in slices taken from MOR CPP treated animals, there was a significant increase in AMPA:NMDA in the MOR group (cf. Billa *et al.*, 2001), with no increase in variability. This is consistent with the hypothesis described in Chapter 4 (Figure 3.16) that morphine treatment itself induces an LTP-like change that can be seen as an increase in AMPA:NMDA during patch-clamp recordings, and as a decrease in the ability of those synapses to display further stimulus-induced LTP. Although no change in AMPAR subunit composition was detected, this does not contradict the LTP hypothesis, as this effect is not consistently seen in other studies (see Introduction). Potentially, this effect could also involve increased dendritic arborisations, as an increase in whole-cell capacitance was seen in the non-contingent MOR group.

A further implication of these results concerns the increase in stimulus-induced LTP seen after exposure to the CPP environment (Chapter 3). As no change in AMPA:NMDA values were seen between SAL and SAL CPP groups, this suggests that the mechanism underlying the increase in stimulus-induced LTP measured during field recordings in Chapter 3 is likely to be via a different mechanism to the one underlying the decrease seen after morphine treatment. The mechanism for the change after CPP exposure was not investigated further, although possible mechanisms are discussed in Chapter 6.

**Chapter 5: Examination of
Presynaptic Changes in CA1
caused by Morphine and
Morphine-induced Place
Preference Using Whole-Cell
Patch Clamp**

5.1 Introduction

In addition to post-synaptic changes LTP in the hippocampal CA1 area may have a pre-synaptic component (see introduction and Chapter 3). The possibility that MOR CPP training may induce presynaptic changes is further investigated in the following chapter, by studying paired pulse facilitation and miniature EPSCs.

5.2 Results

5.2.1 Paired-pulse facilitation of EPSCs following MOR and MOR CPP treatments

As previously mentioned (Chapter 3), one technique that can be used to assess probability of transmitter release is paired-pulse facilitation. An increase in paired-pulse facilitation (PPF) indicates a decrease in initial probability of transmitter release. In field recordings, there was no apparent change in PPF between the treatment groups, but there was a slight but significant reduction after stimulus-induced LTP. One disadvantage of the field recordings (Chapter 3) was that the recordings are of many postsynaptic neurones combined, and so the resolution is much lower than in patch-clamp recordings, where only a single neurone is recorded from. We therefore repeated the paired-pulse facilitation experiments using whole cell patch clamp.

Figure 5.1 demonstrates that when recorded in the patch-clamp configuration (so responses are only recorded from a single neuron) there is a strong and significant increase in PPF in the MOR treatment group, but not in the MOR CPP group.

As with other measured variables including AMPA:NMDA and stimulus-induced LTP, MOR treatment surprisingly gave the most robust effect, and the addition of CPP training with morphine treatment appeared to counteract or prevent the effect of morphine itself. Unlike the postsynaptic changes (see Chapters 3 and 4) there was no significant increase in variability in any of the treatment groups (F-tests: MOR vs. SAL $P=0.87$; SAL CPP vs. SAL $P=0.53$; MOR CPP vs SAL CPP $P=0.32$).

Although there was no significant increase in variance of PPF in the MOR CPP group, in a further attempt to try and identify potential subsets of neuronal responses to MOR CPP, a correlation was plotted between PPF value and AMPA:NMDA in the MOR CPP group. Figure 5.2 shows that there was no significant correlation between the two values.

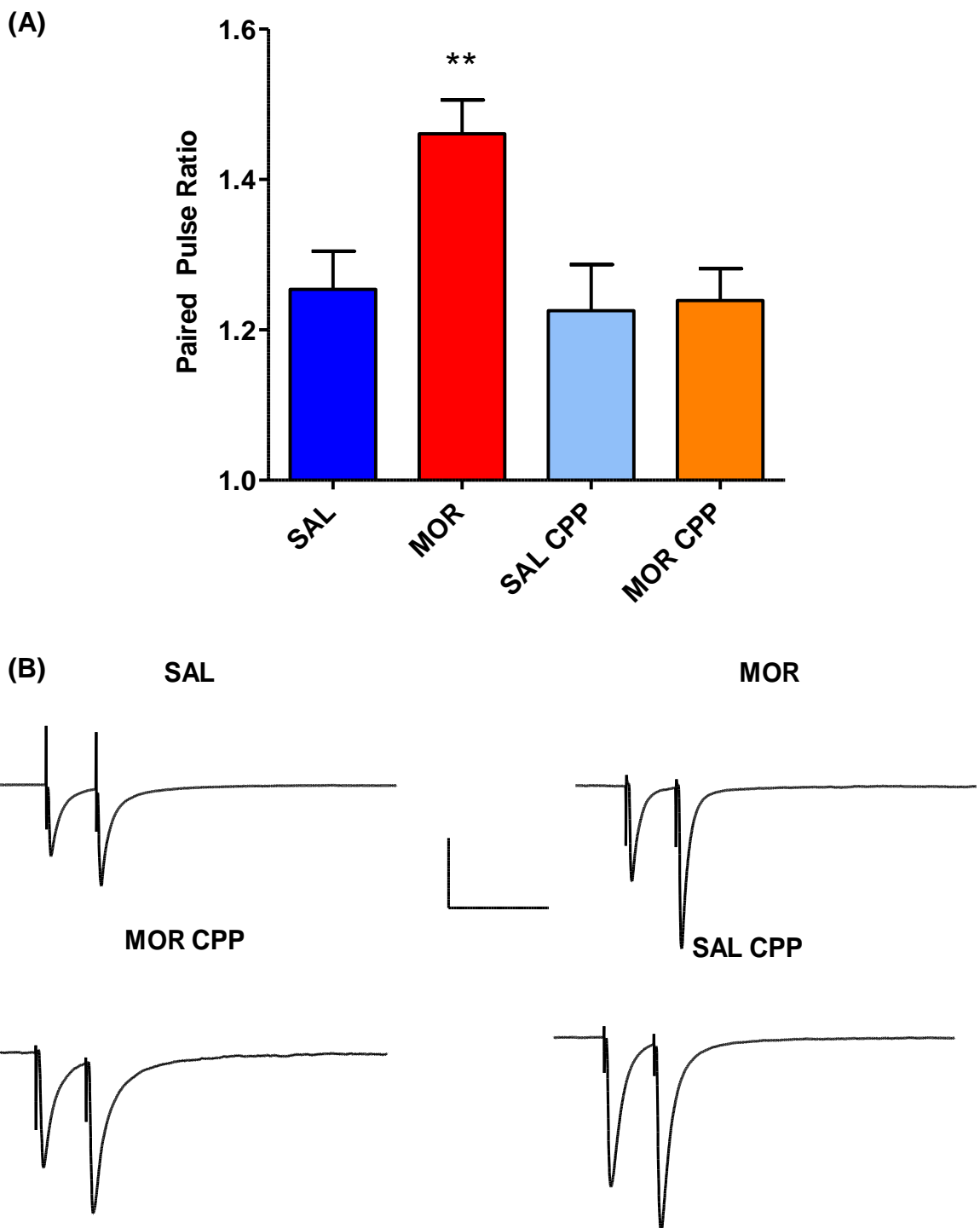

Figure 5.1 Paired pulse ratio at Schaffer-Collateral-CA1 synapses after contingent and non-contingent morphine and saline treatments *in vivo*.

(A) All mice underwent *in vivo* treatments; SAL, MOR, SAL CPP or MOR CPP. Under voltage-clamp at -70mV , EPSCs were evoked 50ms apart and EPSC amplitude of each measured. 'Paired Pulse Ratio' value is the amplitude of second stimulated EPSC divided by the first stimulated EPSC. Data plotted as means \pm S.E.M. SAL $n=7$ from 6 mice, MOR $n=11$ from 6 mice, SAL CPP $n=9$ from 8 mice, MOR CPP $n=9$ from 7 mice. ** = $P < 0.01$; t-test vs. respective SAL controls. Inset trace from a single MOR subject to demonstrate paired pulse facilitation. **(B)** Representative traces from each of the test groups. Calibration bars set at 100ms and 500pA .

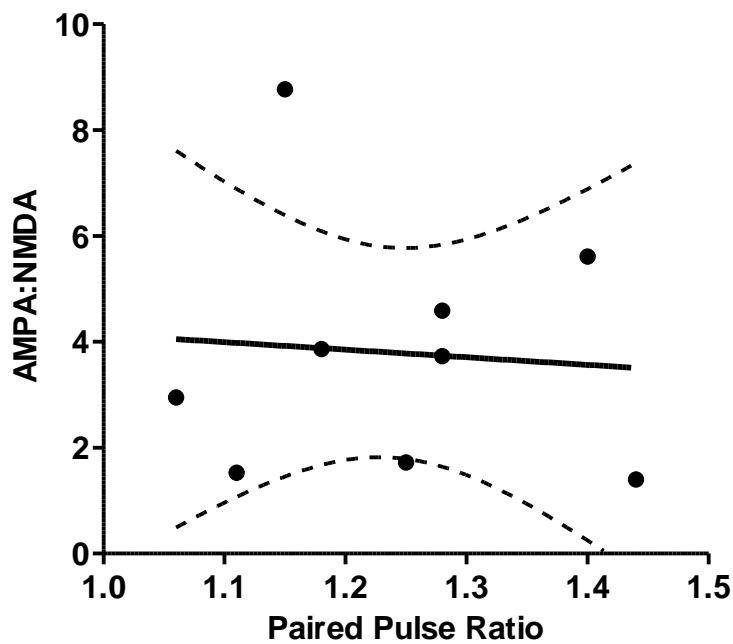

Figure 5.2 Correlation plot of Paired Pulse Ratio and AMPA:NMDA ratios.

All mice underwent MOR CPP treatment. Paired pulse ratio (ratio of amplitude of 2nd EPSC / 1st EPSC, 50 ms apart) is plotted on the x axis. Y axis shows data plotted as AMPA:NMDA in a slice taken from the same neurone. Linear regression analysis was then performed; solid line is line of best-fit, dashed lines are 95% confidence band of regression line. There was no significant correlation between the paired pulse ratio and AMPA:NMDA. $R^2 = 0.006$, $P = 0.84$ for statistical deviance of line-of-best-fit from zero.

5.2.2 Miniature excitatory post-synaptic currents following contingent and non-contingent *in vivo* morphine treatments

A further, more powerful way to investigate presynaptic release probability is to record miniature synaptic events. These events were recorded by a continuous measurement of holding current for at least 30 seconds in the presence of 1 μ M TTX. Figure 5.3 shows that there is a significant increase in inter-event interval of mEPSCs in the MOR treatment group, meaning that there is a significant decrease in the frequency of mEPSCs. There is also a similar but non-significant trend ($P=0.06$) in the MOR CPP vs. SAL CPP comparison. To derive the data shown in Figure 5.3 it is necessary first to take an average of the mEPSC inter-event interval in each individual neurone, then take the mean of those average values. It is usual to plot these types of data as cumulative frequency plots however, whereby the relative distributions of the data can be analysed and thus decrease the chance of a type II error. When drawing cumulative frequency graphs, it is important to ensure that equivalent numbers of events from each neurone (rather than equivalent time of duration of recording) are plotted. This is so that the cumulative frequency is not skewed by neurones with higher frequencies that would inevitably contribute more to the overall number of events.

Figure 5.4 shows the cumulative frequency plot of mEPSCs taken from slices from animals that had undergone either MOR or SAL treatments. The shift to the right in the plot of the MOR group is symptomatic of an overall increase in inter-event interval, and therefore an overall decrease in mEPSC frequency. The Kolmogorov-Smirnov test (K-S test) can be used to assess whether there is a significant difference between the relative distributions of cumulative frequency plots. Using this statistical test gives $P < 0.001$ suggesting a highly significant decrease in mEPSC frequency in neurones taken from animals that had undergone non-contingent morphine *in vivo*. This is in agreement with the mean mEPSC analysis (Figure 5.3)

In contrast to SAL and MOR treatments, there was no significant difference ($P = 0.07$; K-S test) in mEPSC frequency between animals that had undergone SAL CPP and MOR CPP treatments (Figure 5.5).

(A)

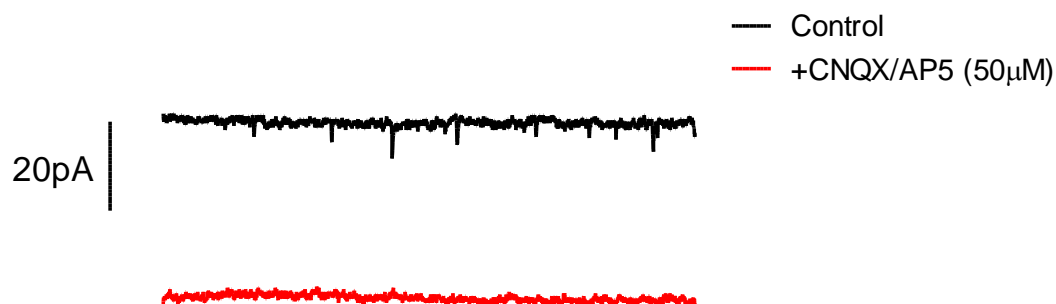

(B)

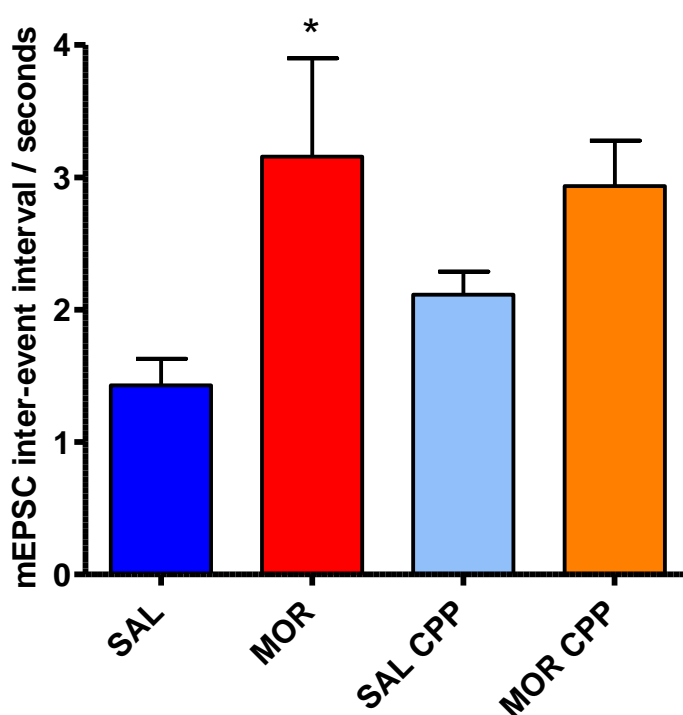

Figure 5.3 Miniature EPSC frequency at Schaffer-Collateral-CA1 synapses after contingent and non-contingent morphine and saline treatments.

(A) A representative example of a mEPSC recording. The addition of CNQX (50µM) and D-AP5 (50µM) abolished all detected events demonstrating all events were of glutamatergic origin. **(B)** All mice underwent *in vivo* treatments; SAL, MOR, SAL CPP or MOR CPP. mEPSCs were recorded and inter-event intervals measured. For each neurone the mean inter-event interval was taken, those values were then averaged and plotted (means ± S.E.M.). SAL n=5 from 5 mice, MOR n=4 from 4 mice, SAL CPP n=5 from 5 mice, MOR CPP n=4 from 4 mice. * = $P < 0.05$ MOR vs. SAL.

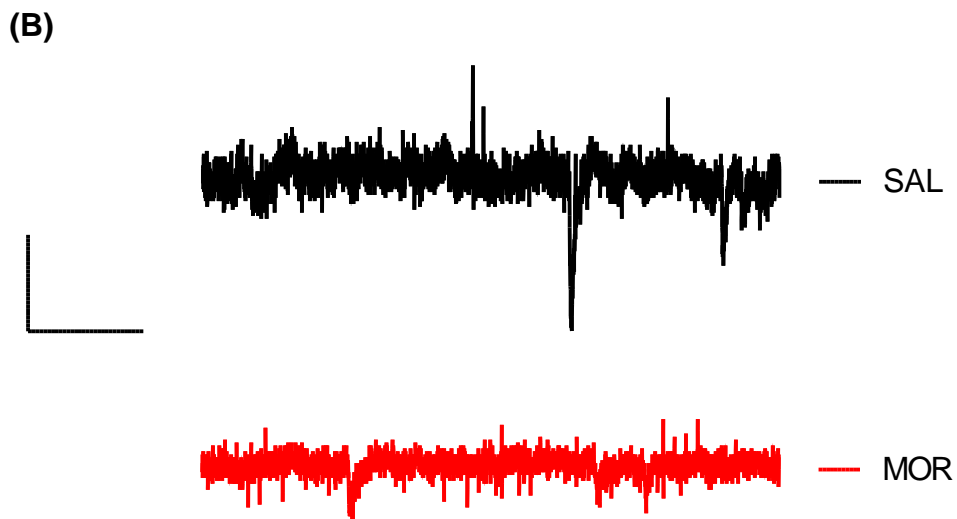
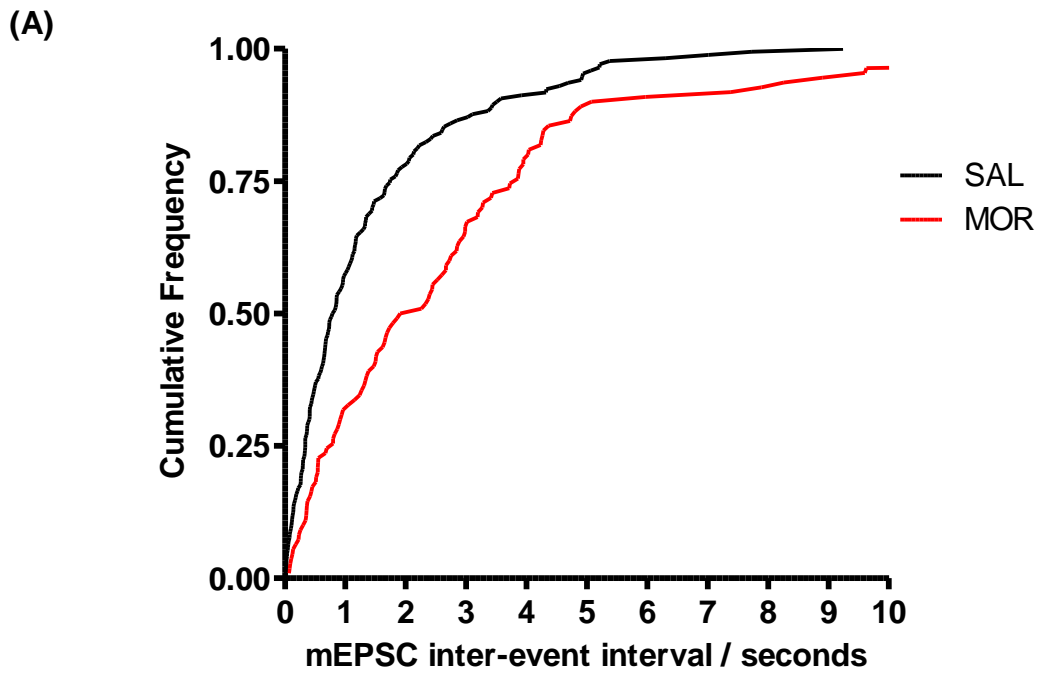

Figure 5.4 Miniature EPSC frequency at Schaffer-Collateral-CA1 synapses after SAL or MOR treatments.

(A) Mice underwent either SAL ($n=5$) or MOR ($n=4$) treatments. mEPSCs were recorded and inter-event intervals measured. Each event was ranked and plotted as a cumulative frequency plot. **(B)** Representative sample (1 second) of each test group. Calibration bars are set to 200ms and 10pA.

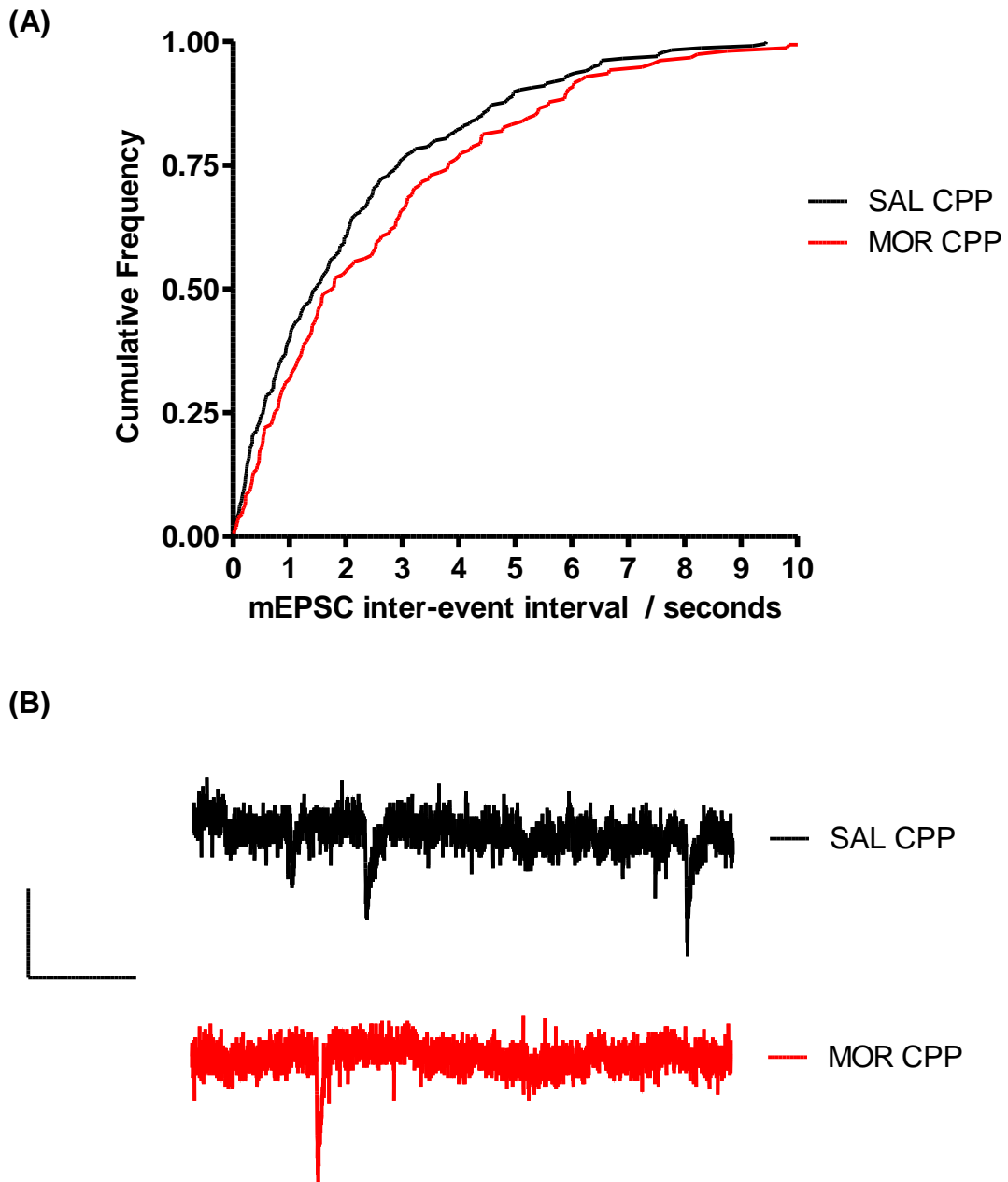

Figure 5.5 Miniature EPSC frequency at Schaffer-Collateral-CA1 synapses after conditioned place preference.

(A) Mice underwent either SAL CPP ($n=5$) or MOR CPP ($n=4$) treatments. mEPSCs were recorded and inter-event intervals measured. Each event was ranked and plotted as a cumulative frequency plot. **(B)** Representative sample (1 second) of each test group. Calibration bars are set to 200ms and 10pA.

As well as frequency, the amplitude of mEPSCs was measured. It is generally assumed that a decrease in mEPSC frequency (see Figure 5.4) is indicative of a decrease in probability of glutamate release, although further support is often provided by studying mEPSC amplitudes.

Plotting the average mEPSC amplitudes within each neurone revealed there were no significant differences between treatment groups. As already mentioned above however, this approach can lead to an increase in type II errors. The data were therefore plotted as cumulative frequency plots. Figures 5.7 and 5.8 clearly show that there is no significant difference in mEPSC amplitudes between the different *in vivo* treatment groups. Therefore the significant decrease in mEPSC frequency after MOR shown above (Figure 5.3) is likely to be caused by a decrease in glutamate release probability at nerve terminals making synapses onto CA1 neurones in the striatum radiatum. This idea is further supported by the findings of the paired pulse experiments (Figure 5.1).

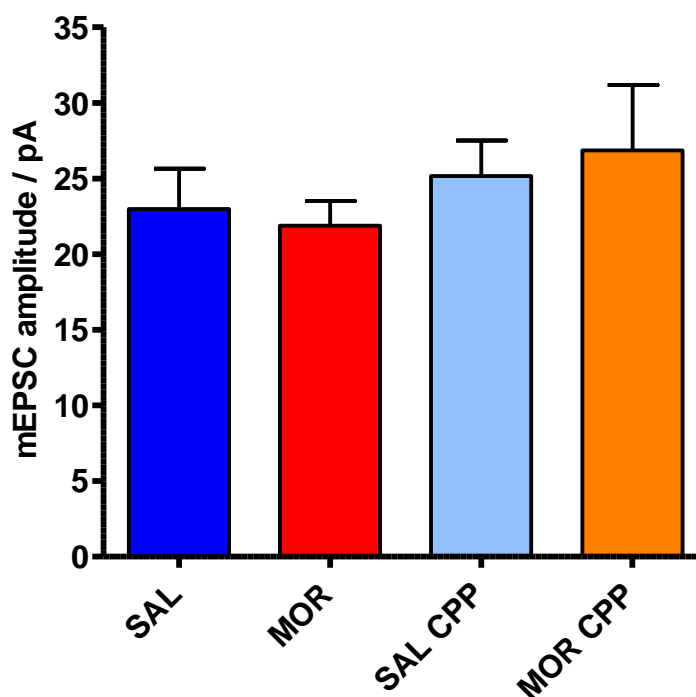

Figure 5.6 Miniature EPSC amplitude at Schaffer-Collateral-CA1 synapses after different *in vivo* treatments.

All mice underwent in vivo treatments; SAL, MOR, SAL CPP or MOR CPP. mEPSCs were recorded and amplitudes measured. For each neurone the mean mEPSC amplitude was taken, those values were then averaged and plotted as the mean \pm S.E.M. n = 4-5 per treatment group.

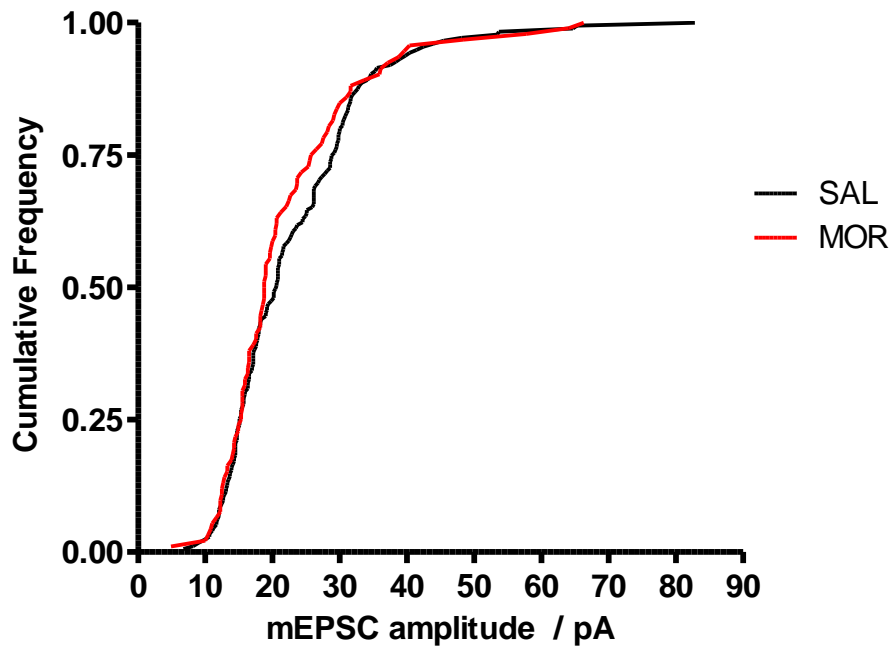

Figure 5.7 Miniature EPSC amplitude at Schaffer-Collateral-CA1 synapses after MOR or SAL treatments.

Mice underwent either SAL or MOR treatment. mEPSCs were recorded and amplitudes measured in pA. Each event was ranked and plotted as a cumulative frequency plot. $n = 4-5$ neurones per treatment group. $P = 0.3$; K-S test.

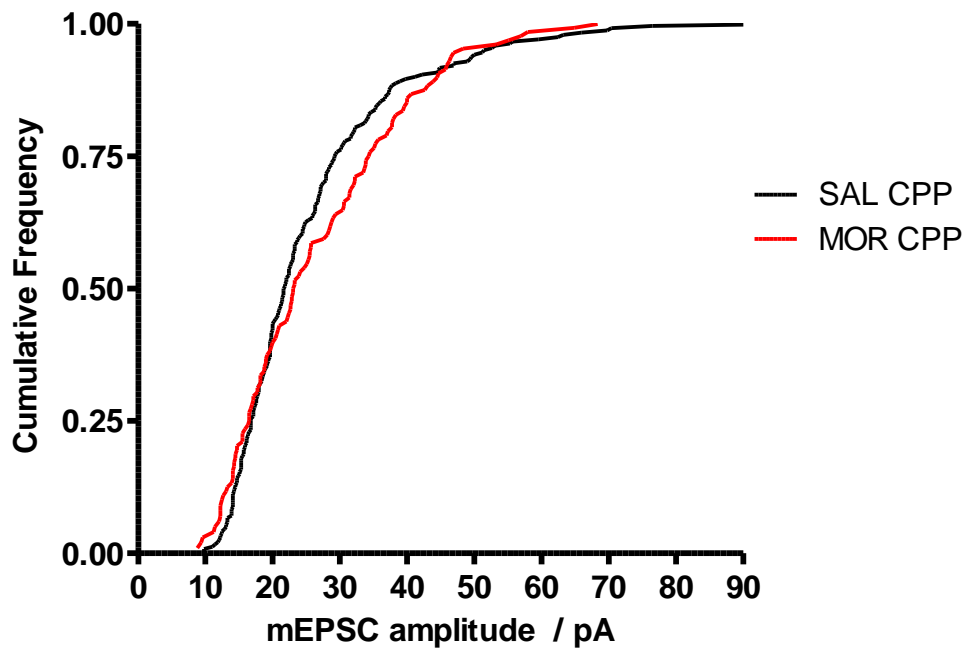

Figure 5.8 Miniature EPSC amplitude at Schaffer-Collateral-CA1 synapses after conditioned place preference.

Mice underwent either SAL CPP or MOR CPP treatment. mEPSCs were recorded and amplitudes in pA measured. Each event was ranked and plotted as a cumulative frequency plot. $n = 4-5$ neurones per treatment group. $P = 0.13$; K-S test.

5.2.3 Properties of miniature excitatory post-synaptic currents following contingent and non-contingent *in vivo* morphine treatments

In addition to providing information about release probability, miniature EPSCs can also provide information about the nature of synapses in neurones from which the events are recorded. Specifically, the rise times of events are generally seen as an indicator of how far away from the recording site the events occur (Smith *et al.* 2003; Gonzales-Burgos *et al.* 2009; Han *et al.* 2013). For example, with whole-cell patch-clamp recordings, where the recording itself is taken from the cell soma, if a mEPSC occurs at a distal dendrite the rise time is longer (ie. slower) than if the event occurred at a proximal dendrite. Therefore, rise times can give an indication of either the level of dendritic arborisation in an individual neuron, or of the relative distribution of synapses along a neurone. Therefore, mEPSC rise times were analysed (for means see Figure 5.9, cumulative frequency plots 5.10 and 5.11). Unpaired t-tests failed to find any significant differences between the groups ($P > 0.05$ for both SAL vs. MOR and SAL CPP vs. MOR CPP comparisons). K-S tests also failed to find any differences between the relative distributions of mEPSC rise times for SAL vs. MOR ($P = 0.46$). There was a non-significant trend toward longer rise times in the MOR CPP group compared to SAL CPP however ($P = 0.09$). It would be interesting to know if this increase in mEPSC rise time is correlated in any way to AMPA:NMDA in individual cells, however these two measurements were never taken from the same cell due to technical issues (see Appendix).

While rise times are an indicator of proximity of synapses from recording site, there is generally no correlation between decay times and rise times of miniature events, and decay times are thought of as an indicator of subunit composition (McBain & Dingledine, 1992; Okada *et al.*, 2000; Smith *et al.*, 2003). Analysis of mEPSC decay times revealed that there was no significant change in decay times between the different *in vivo* treatment groups (Figures 5.12 – 5.14). This supports the finding of earlier experiments (Figure 4.18) that suggested no change in AMPAR subunit composition had occurred following any of the *in vivo* treatments.

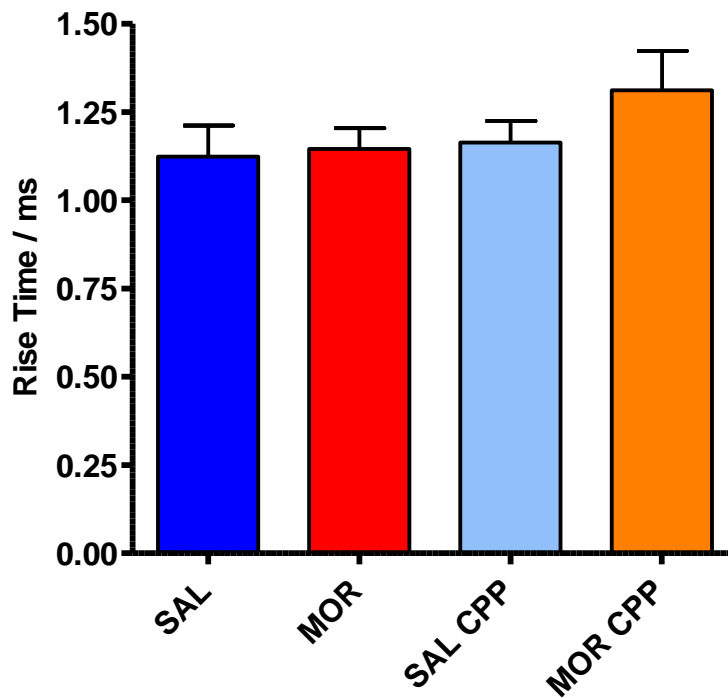

Figure 5.9 Miniature EPSC rise times at Schaffer-Collateral-CA1 synapses after *in vivo* treatments.

*All mice underwent in vivo treatments; SAL, MOR, SAL CPP or MOR CPP. mEPSCs were recorded and rise times in milliseconds (ms) measured. For each neurone the mean mEPSC rise time was taken, those values were then averaged and plotted as mean \pm S.E.M. $n = 4-5$ per treatment group. Unpaired *t*-tests for both MOR and MOR CPP against their respective controls failed to detect any significant difference.*

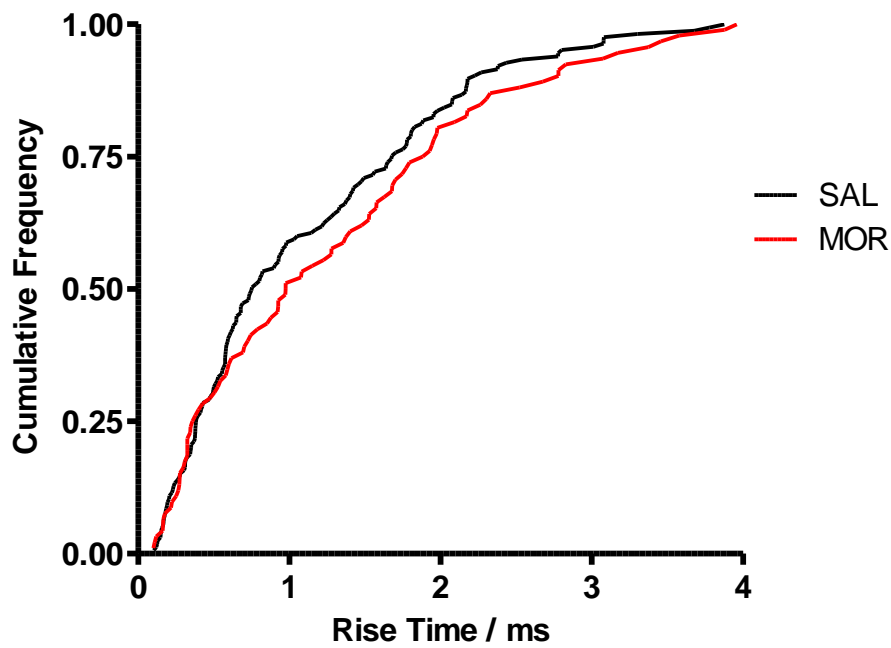

Figure 5.10 Miniature EPSC rise times at Schaffer-Collateral-CA1 synapses after SAL or MOR treatments.

Mice underwent either SAL or MOR treatment. mEPSCs were recorded and rise times measured (ms). Each event was ranked and plotted as a cumulative frequency plot. $n = 4-5$ neurones per treatment group. $P = 0.46$; K-S test.

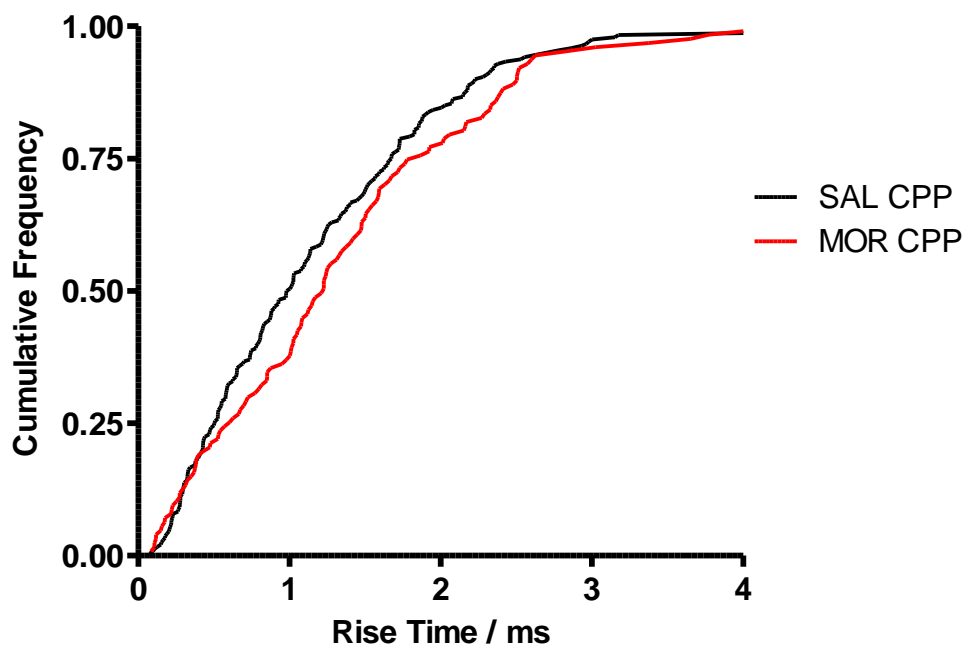

Figure 5.11 Miniature EPSC rise times at Schaffer-Collateral-CA1 synapses after conditioned place preference.

Mice underwent either SAL CPP or MOR CPP treatment. mEPSCs were recorded and rise times (ms) measured. Each event was ranked and plotted as a cumulative frequency plot. $n = 4-5$ neurones per treatment group. $P = 0.09$; K-S test.

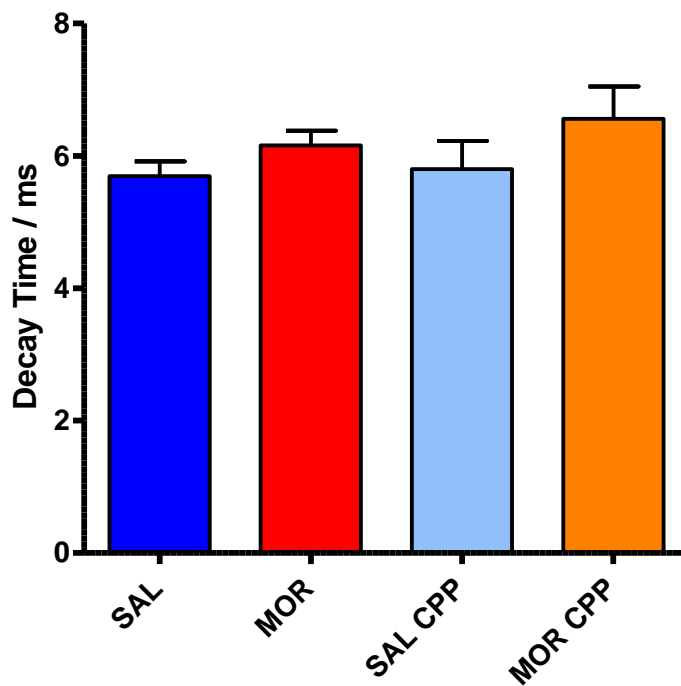

Figure 5.12 Miniature EPSC decay times at Schaffer-Collateral-CA1 synapses after *in vivo* treatments.

All mice underwent in vivo treatments; SAL, MOR, SAL CPP or MOR CPP. mEPSCs were recorded and decay times in milliseconds (ms) measured. For each neurone the mean mEPSC decay times (ms) was taken, those values were then averaged and plotted as mean \pm S.E.M. n = 4-5.

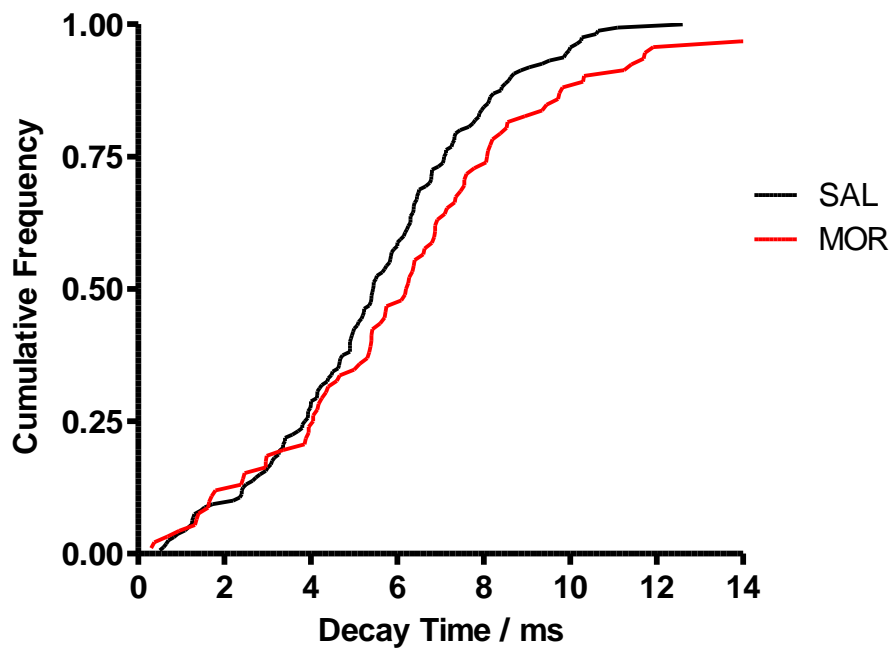

Figure 5.13 Miniature EPSC decay times at Schaffer-Collateral-CA1 synapses after SAL or MOR treatments.

Mice underwent either SAL or MOR treatments. mEPSCs were recorded and decay times measured (ms). Each event was ranked and plotted as a cumulative frequency plot. $n = 4-5$ neurones per treatment group. $P = 0.2$; K-S test.

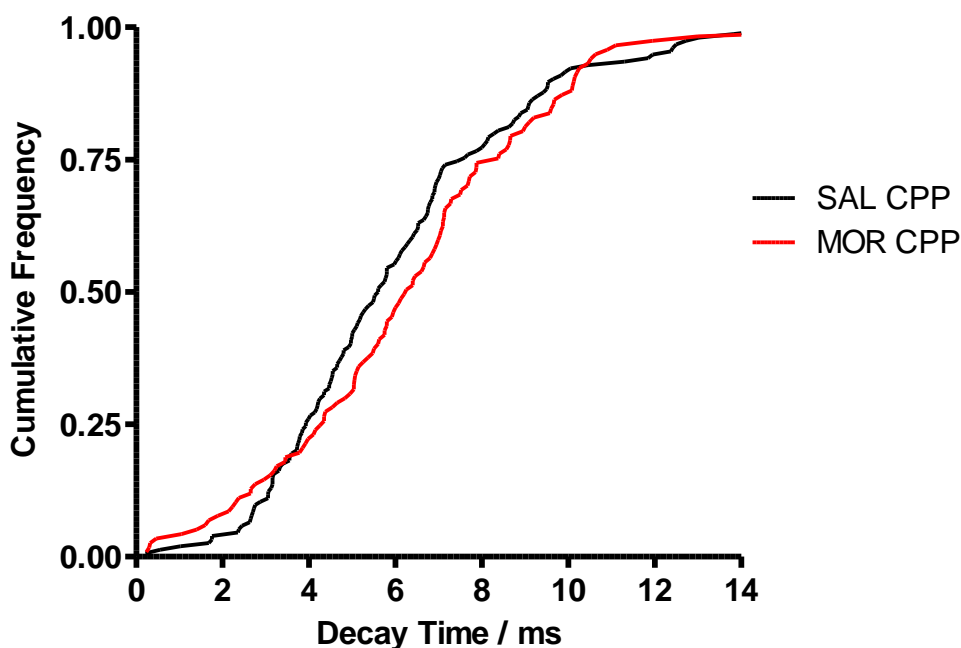

Figure 5.14 Miniature EPSC decay times at Schaffer-Collateral-CA1 synapses after conditioned place preference.

Mice underwent either SAL CPP or MOR CPP treatment. mEPSCs were recorded and decay times (ms) measured. Each event was ranked and plotted as a cumulative frequency plot. $n = 4-5$ neurones per treatment group. $P = 0.3$; K-S test.

Summarising the results from Chapter 5 so far, it appears that MOR treatment may decrease glutamate release probability in CA1, whereas MOR CPP has less clear effects. This finding is based on the evidence that MOR treatment both increases paired pulse facilitation (Figure 5.1) and decreases the frequency of mEPSCs (Figure 5.4) whilst leaving the amplitude and decay times of mEPSCs unaffected (Figures 5.7 and 5.13). The effects of MOR CPP treatment seem much less clear, paired pulse facilitation is unaffected (Figure 5.1), mEPSC frequency is not affected significantly (although shows a decreasing trend, Figure 5.5), and amplitude and decay times are unaffected (Figures 5.8 and 5.14). It is worth noting that the possible decrease in mEPSC frequency in the MOR CPP group is not supported by the paired pulse facilitation data. This could suggest that mEPSC frequency measurements as an indicator of probability of glutamate release is a more sensitive measure, or more likely, that the trend to a decrease in mEPSC frequency suggested by the K-S test ($p=0.06$) is really due to chance.

As already mentioned in the Introduction, glutamate is not the only neurotransmitter in the CA1 area, numerous GABAergic interneurons as well as direct GABAergic projections from the septal nuclei also exist. During the recording of mEPSCs, the glutamate miniature synaptic events were isolated by clamping the membrane potential close to the equilibrium potential (V_{eq}) of chloride ions. This reduced GABA_A mediated currents to undetectable levels (see Figure 5.3(A)). It was possible therefore to also study miniature synaptic GABAergic events by clamping the membrane potential close to the reversal potential for the glutamate mediated current (see below).

5.2.4 Miniature inhibitory post-synaptic currents following in vivo treatments

In addition to measuring release of glutamate onto CA1 neurones, release of GABA was assessed by recording miniature IPSCs (mIPSCs). Figures 5.15 – 5.17 show that there was a significant increase in mIPSC inter-event interval, and so a significant decrease in mIPSC frequency, both in the MOR and MOR CPP groups. Although when data were averaged and analysed using unpaired t-tests (Figure 5.15) there was only a non-significant trend, there was a clear increase when cumulative frequency plots were analysed using the Kolmogorov-Smirnov statistical test (Figures 5.16-5.17).

These data suggest that there was a significant decrease in probability of GABA release onto CA1 neurones in brain slices taken either from MOR or MOR CPP treated animals. As with mEPSCs, to confirm that a decrease in mIPSC frequency is truly a reflection of decreased probability of transmitter release, it is important to ascertain that mIPSC amplitude is not affected. Figures 5.18 – 5.20 show that prior morphine treatment (whether given in a specific context or not) had no effect on mIPSC amplitude.

(A)

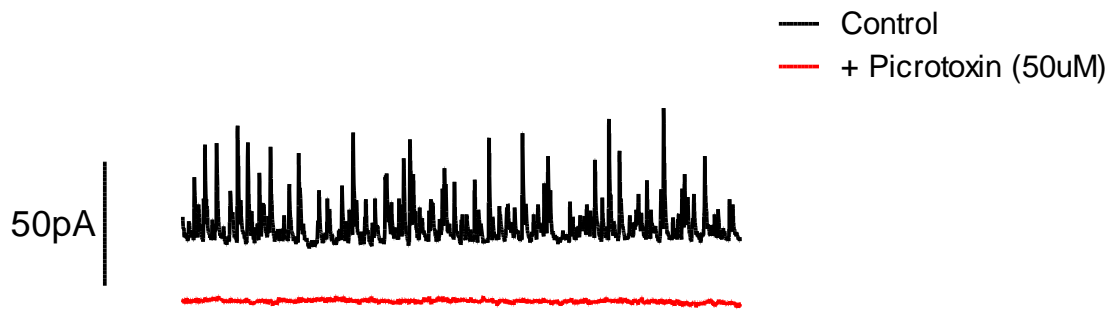

(B)

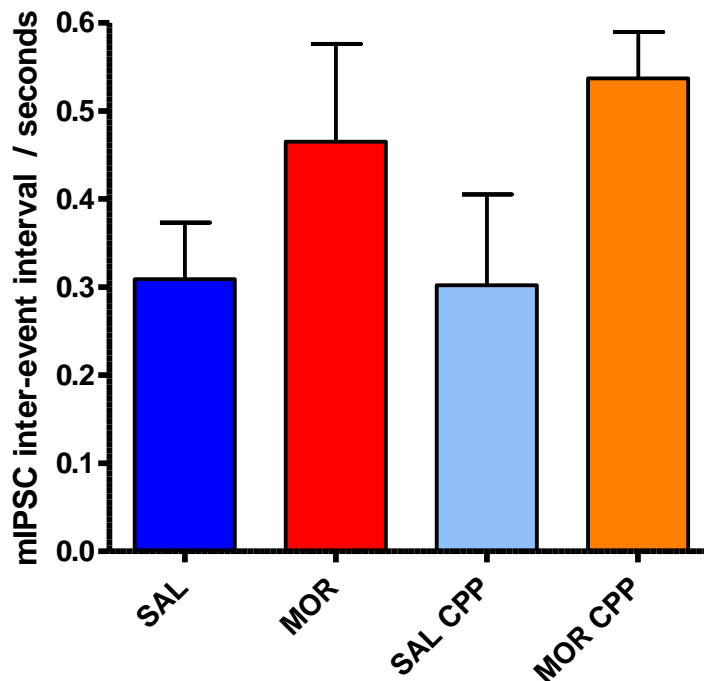

Figure 5.15 Miniature IPSC frequency at Schaffer-Collateral-CA1 synapses after *in vivo* treatments.

(A) A representative example of a mIPSC recording. The addition of the GABA_A antagonist picrotoxin (50 μ M) abolished all detected events, demonstrating all events were of GABAergic origin. (B) All mice underwent *in vivo* treatments; SAL (n=4 from 4 mice), MOR (n=3 from 3 mice), SAL CPP (n=4 from 4 mice), or MOR CPP (n=3 from 3 mice). mIPSCs were recorded and inter-event intervals measured. For each neurone the mean inter-event interval was taken, those values were then averaged and plotted as means \pm S.E.M.

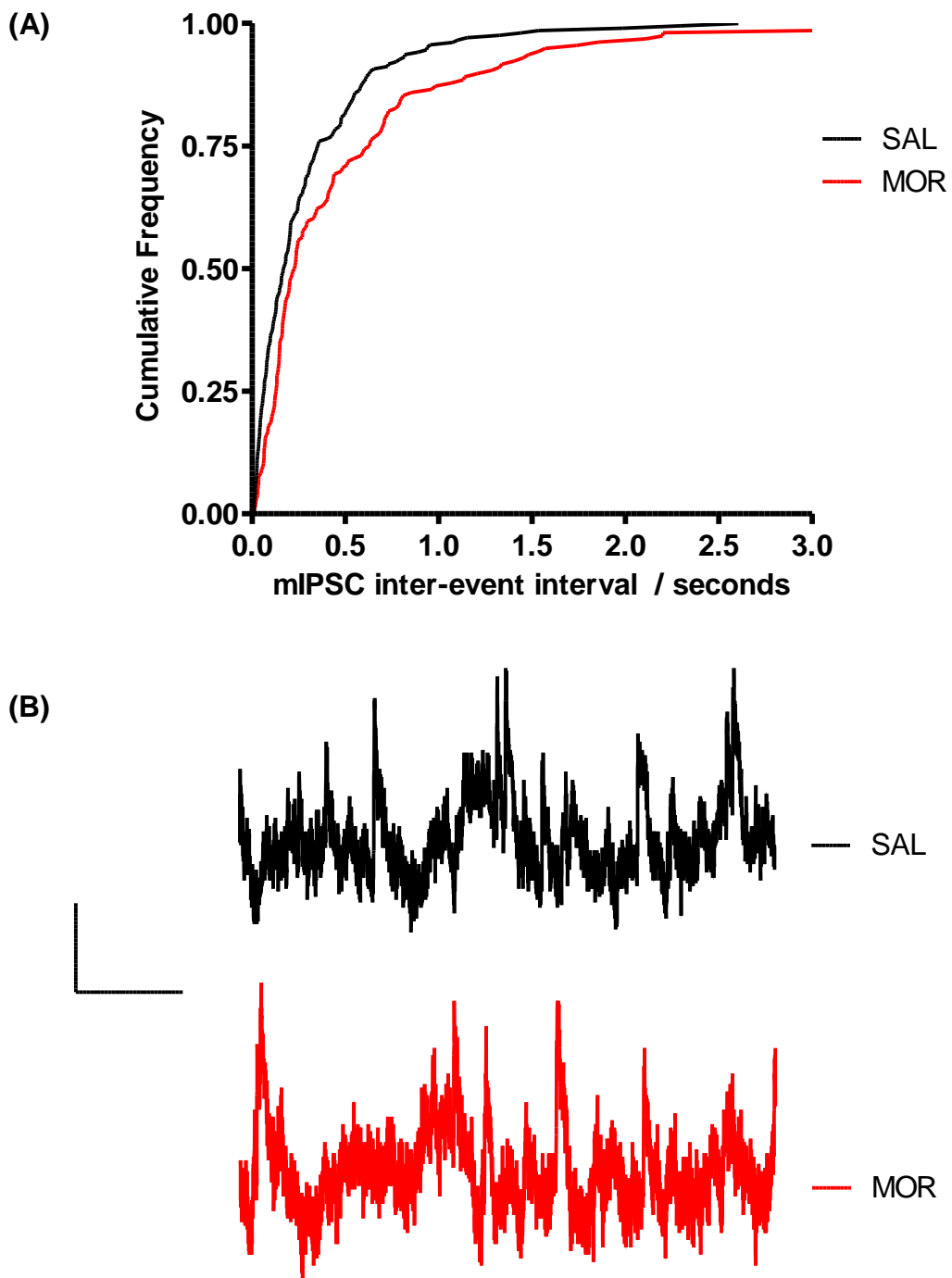

Figure 5.16 Miniature IPSC frequency at Schaffer-Collateral-CA1 synapses after MOR or SAL treatments.

(A) Mice underwent either SAL or MOR treatments. mIPSCs were recorded and inter-event intervals measured. Each event was ranked and plotted as a cumulative frequency plot. SAL vs. MOR, $P = 0.004$ in K-S test. **(B)** Representative sample (1 second) of each test group. Calibration bars are set to 200ms and 10pA.

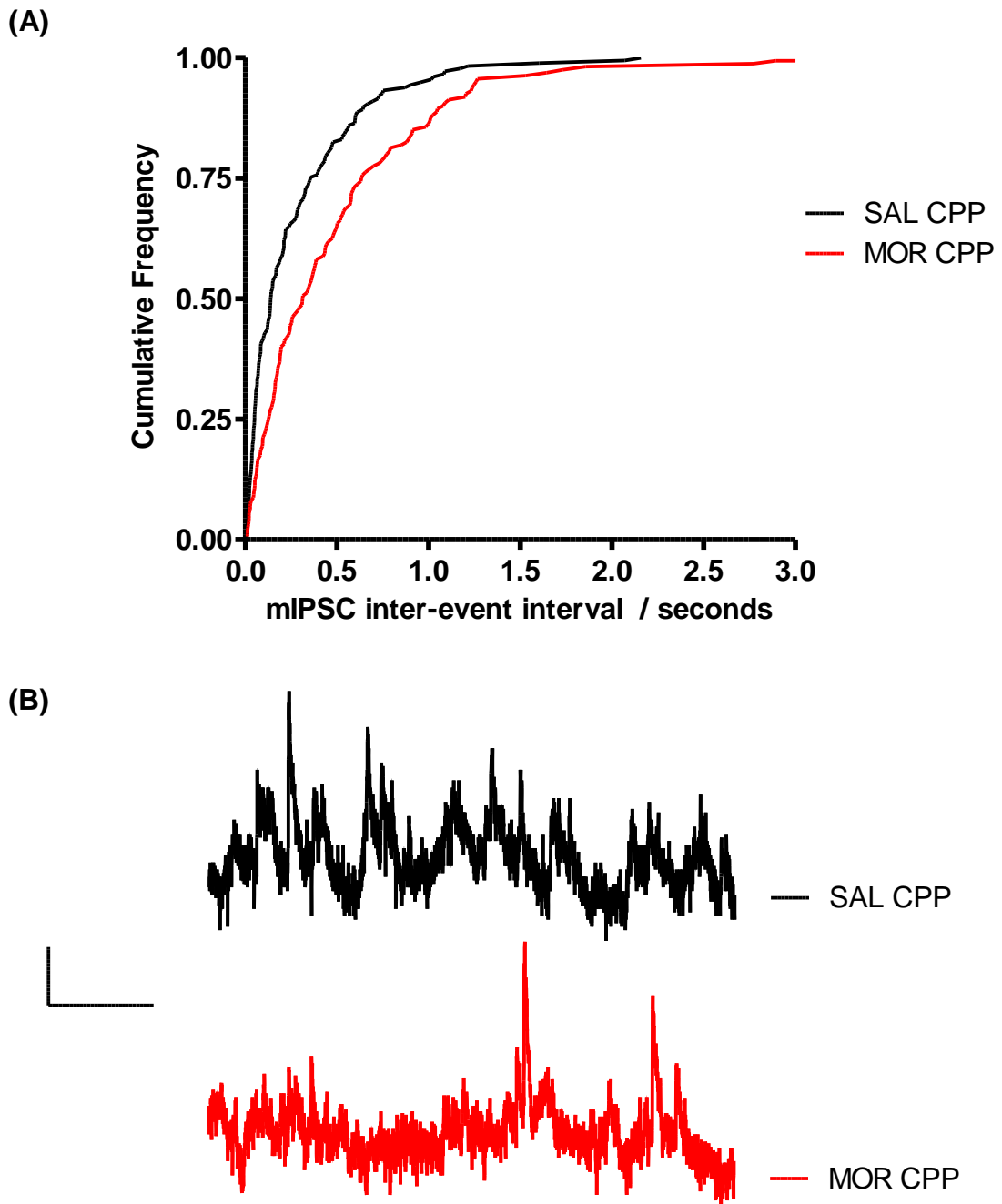

Figure 5.17 Miniature IPSC frequency at Schaffer-Collateral-CA1 synapses after conditioned place preference.

(A) Mice underwent either SAL CPP or MOR CPP treatment. mIPSCs were recorded and inter-event intervals measured. Each event was ranked and plotted as a cumulative frequency plot. $n = 3-4$ neurones per treatment group. $P < 0.001$; K-S test. **(B)** Representative sample (1 second) of each test group. Calibration bars are set to 200ms and 10pA.

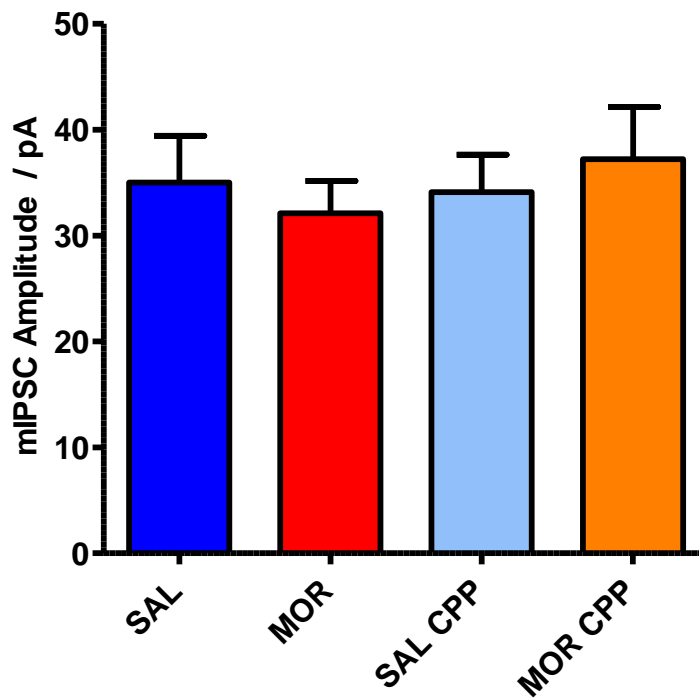

Figure 5.18 Miniature IPSC amplitude at Schaffer-Collateral-CA1 synapses after *in vivo* treatments.

All mice underwent in vivo treatments; SAL, MOR, SAL CPP or MOR CPP. mIPSCs were recorded and amplitudes measured. For each neurone the mean mIPSC amplitude was taken, those values were then averaged and plotted as means \pm S.E.M. n = 3-4 per treatment group.

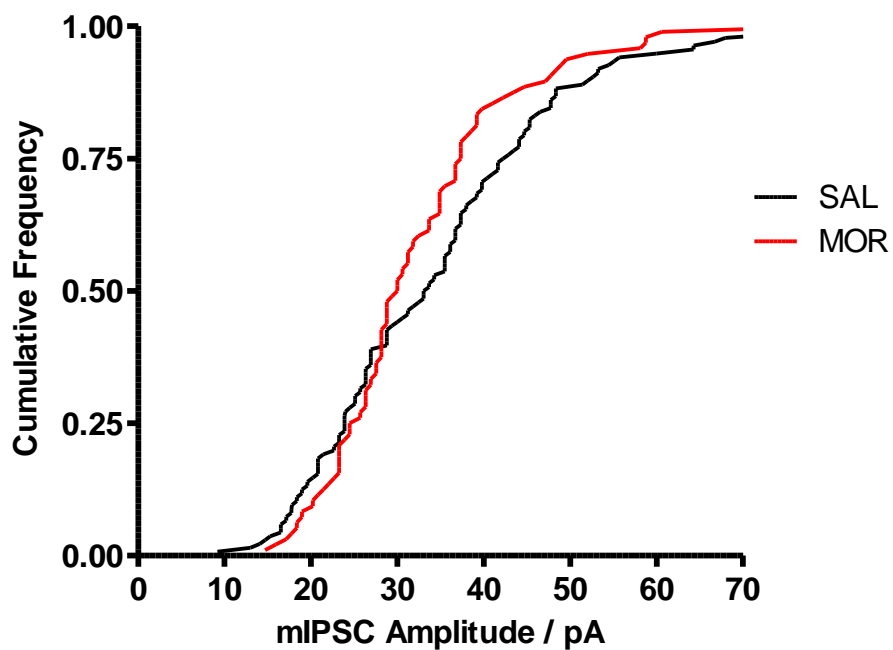

Figure 5.19 Miniature IPSC amplitude at Schaffer-Collateral-CA1 synapses after SAL or MOR treatments.

Mice underwent either SAL or MOR treatment. mIPSCs were recorded and amplitudes measured (pA). Each event was ranked and plotted as a cumulative frequency plot. $n = 3-4$ neurones per treatment group. $P = 0.1$; K-S test.

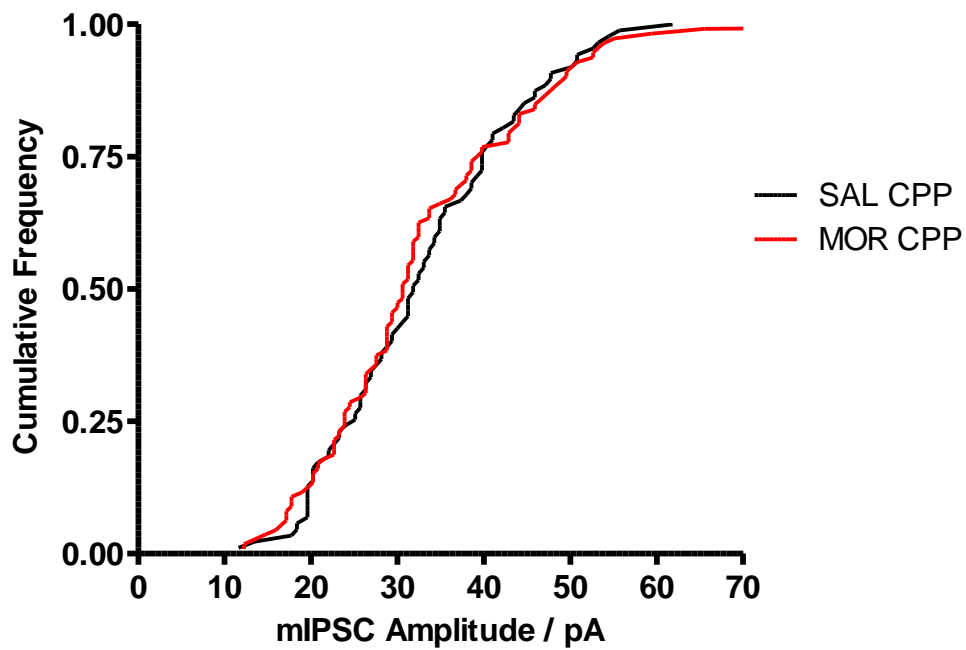

Figure 5.20 Miniature IPSC amplitude at Schaffer-Collateral-CA1 synapses after conditioned place preference.

Mice underwent either SAL CPP or MOR CPP treatment. mIPSCs were recorded and amplitudes (pA) measured. Each event was ranked and plotted as a cumulative frequency plot. $n = 3-4$ neurones per treatment group. $P = 0.7$; K-S test.

5.2.5 Properties of miniature inhibitory post-synaptic currents following in vivo morphine treatments

As with mEPSCs, additional synaptic information can be gathered by the analysis of mIPSC events by analysing rise times and decay times. Figures 5.21 – 5.23 show that there was an apparent increase in the mIPSC rise time in the MOR treated group, but not in the MOR CPP group. Although there was a non-significant trend when rise times were averaged, when the cumulative frequency plot was analysed with the Kolmogorov-Smirnov test, the difference between rise times in the SAL and MOR groups was highly significant.

Unlike with rise times, there was no significant difference in mIPSC decay times between each treatment group (Figures 5.24 to 5.26).

Put together, these data from mIPSC recordings suggest that morphine, whether administered in a specific context or not, results in an overall decrease in probability of GABA release onto CA1 neurones (assuming GABA_A currents are representative of neurone wide GABA activity). Furthermore, the significant increase in rise times only in the MOR treatment group suggests that a greater proportion of GABAergic synapses are now at more distal dendritic locations. There are two possible explanations for this. The first explanation also considers the decrease in GABAergic release probability, concluding that the reduction may have occurred selectively at proximally located GABAergic synapses. A problem with this argument is that it fails to explain why in the MOR CPP group no increase in rise times are seen but a decrease in GABAergic release probability is. The second explanation is that the creation of more GABAergic synapses at distal locations is coupled with a global decrease in release probability. This argument is also supported by evidence from Figure 4.7 that suggested that whole cell capacitance is selectively increased in the MOR treated group. Perhaps therefore this increase in whole cell capacitance is due to the formation of new distally located GABAergic synapses.

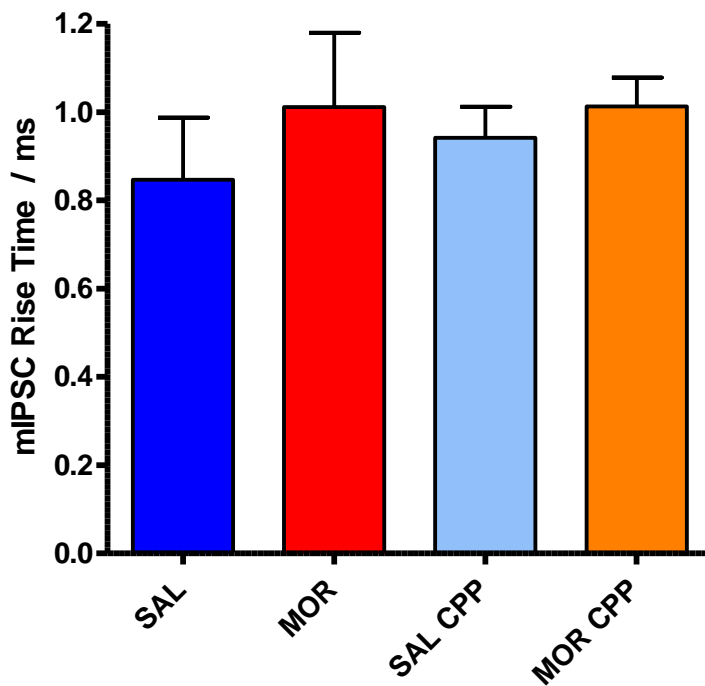

Figure 5.21 Miniature IPSC rise times at Schaffer-Collateral-CA1 synapses after contingent and non-contingent morphine and saline treatments.

All mice underwent in vivo treatments; SAL, MOR, SAL CPP or MOR CPP. mIPSCs were recorded and rise times in milliseconds (ms) measured. For each neurone the mean mIPSC amplitude was taken, those values were then averaged and plotted as means \pm S.E.M. $n = 3-4$ per treatment group.

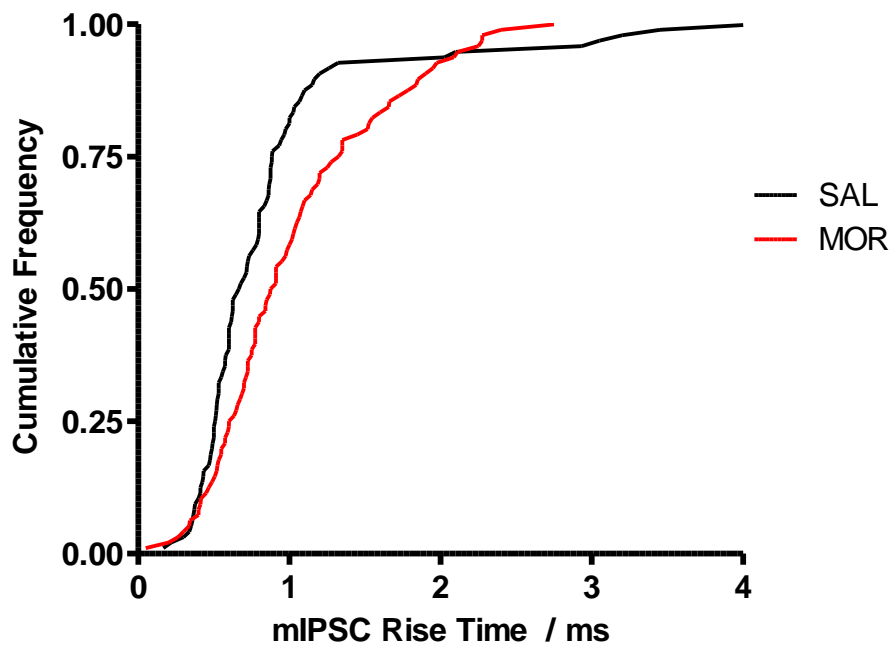

Figure 5.22 Miniature IPSC rise times at Schaffer-Collateral-CA1 synapses after SAL or MOR treatments.

Mice underwent either SAL or MOR in vivo treatments. mIPSCs were recorded and rise times measured (ms). Each event was ranked and plotted as a cumulative frequency plot. $n = 3-4$ neurones per treatment group. $P = 0.001$; K-S test.

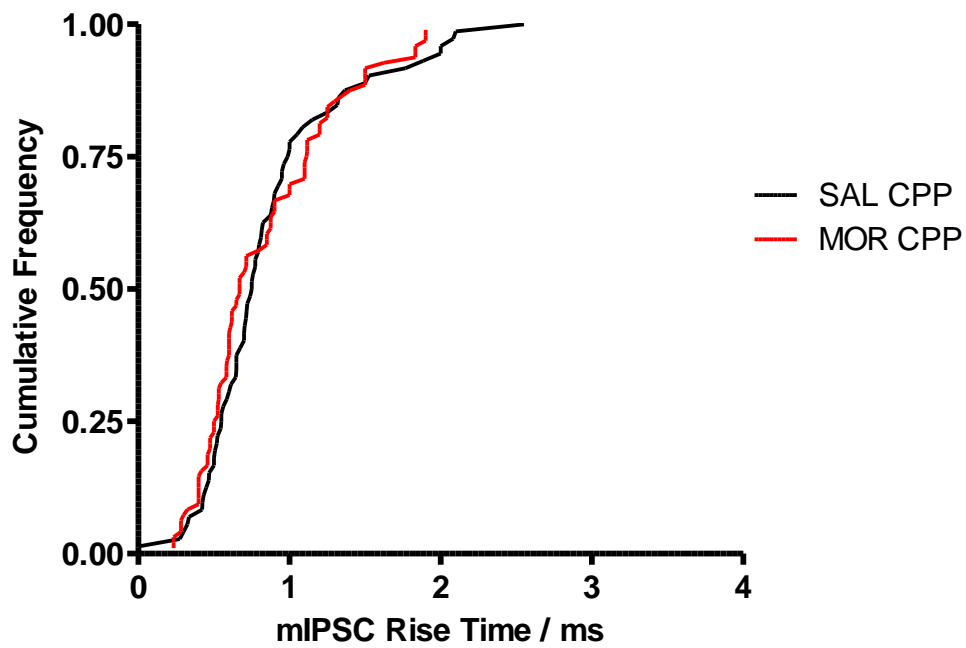

Figure 5.23 Miniature IPSC rise times at Schaffer-Collateral-CA1 synapses after conditioned place preference.

Mice underwent either SAL CPP or MOR CPP treatment. mIPSCs were recorded and rise times (ms) measured. Each event was ranked and plotted as a cumulative frequency plot. $n = 3-4$ neurones per treatment group. $P = 0.13$; K-S test.

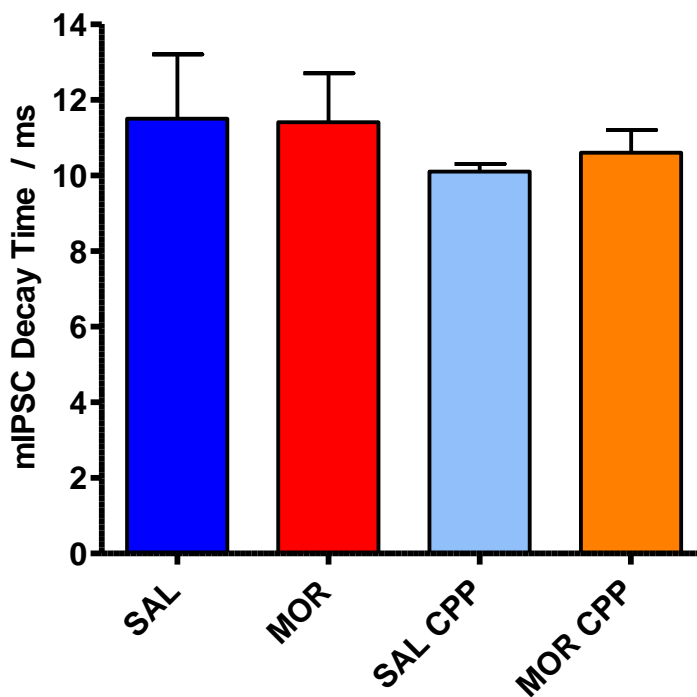

Figure 5.24 Miniature IPSC decay times at Schaffer-Collateral-CA1 synapses after *in vivo* treatments.

All mice underwent in vivo treatments; SAL, MOR, SAL CPP or MOR CPP. mIPSCs were recorded and decay times in milliseconds (ms) measured. For each neurone the mean mIPSC decay time was taken, those values were then averaged and plotted as means \pm S.E.M. n = 3-4 per treatment group.

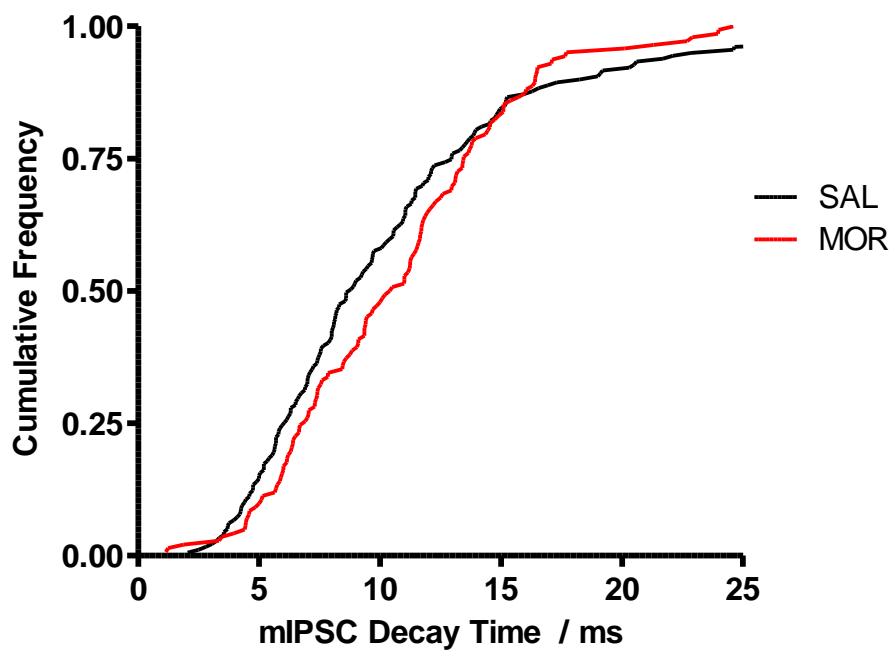

Figure 5.25 Miniature IPSC decay times at Schaffer-Collateral-CA1 synapses after SAL or MOR treatment.

Mice underwent either SAL or MOR treatment. mIPSCs were recorded and decay times measured (ms). Each event was ranked and plotted as a cumulative frequency plot. $n = 3-4$ neurones per treatment group. $P = 0.12$; K-S test.

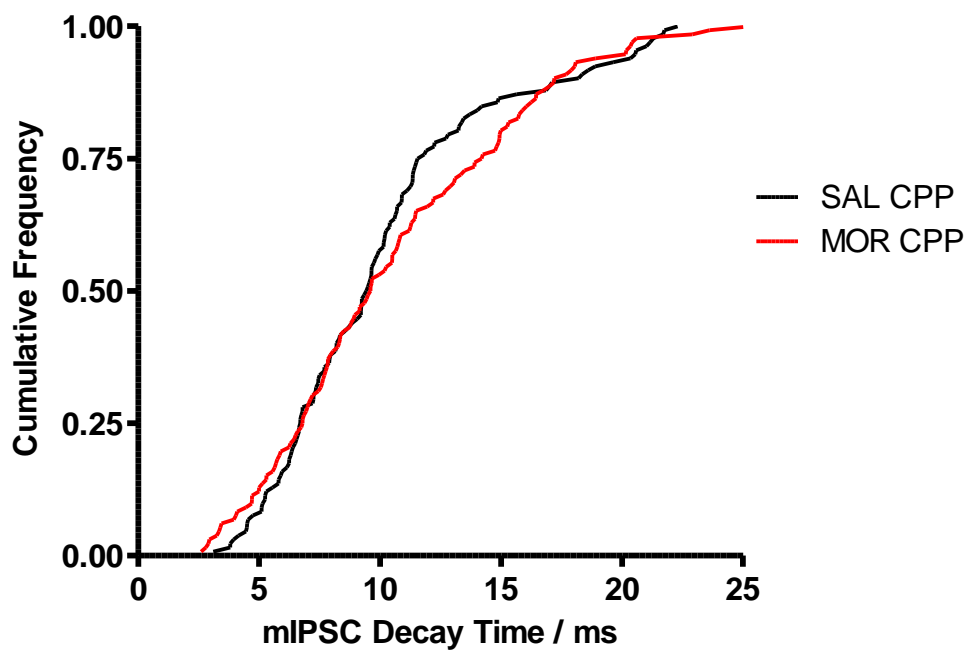

Figure 5.26 Miniature IPSC decay times at Schaffer-Collateral-CA1 synapses after conditioned place preference.

Mice underwent either SAL CPP or MOR CPP. mIPSCs were recorded and decay times (ms) measured. Each event was ranked and plotted as a cumulative frequency plot. $n = 3-4$ neurones per treatment group. $P = 0.3$; K-S test.

5.3 *Summary*

In this chapter the presynaptic properties of synapses on CA1 pyramidal cell dendrites were examined. The major findings were that non-contingent morphine (MOR) treatment appeared to reduce neurotransmitter release probability at both glutamatergic and GABAergic synapses. On the other hand, MOR CPP treatment appeared to either mask or prevent the decrease in glutamatergic release probability whilst GABAergic release probability remained reduced. In the MOR group, but not in the MOR CPP group, there was also an increase in rise times of miniature IPSCs, indicative of proportionally more GABAergic events coming from more distal dendritic synapses. Together with the finding that miniature IPSC frequency was decreased in this group this suggests that non-contingent MOR treatment selectively prunes GABAergic input at more proximal synapses in these neurones. This effect was seemingly absent in the MOR CPP treated animals. While this result would undoubtedly be an interesting one, the shape of the curves in Figure 5.22 suggests that more experiments are needed to confirm this result.

This chapter concludes the Results section of this work. In the following chapter these results are discussed in the context of current literature and implications of this work explored.

Chapter 6: General Discussion

6.1 Introduction

In this chapter, the results from Chapters 3, 4 and 5 are discussed. The chapter will begin with a discussion of the conditioned place preference protocol and its implications for the interpretation of the electrophysiological data. Next, the effects of morphine and morphine-induced CPP on stimulus-induced LTP are interpreted, first separately and then together in an attempt to identify any specific effects of drug related learning. This pattern (treating the four experimental groups first as two individual experiments (SAL vs. MOR and SAL CPP vs. MOR CPP) then together as one experiment), is then repeated in further sections considering the likely location and mechanism of these changes.

6.2 Morphine-induced conditioned place preference

In both Figure 3.3 and Figure 4.1 subjects in the MOR CPP group spent significantly more time in the drug-paired compartment on the test day compared to the pre-test day. The purpose of demonstrating CPP prior to electrophysiological analysis was in order to study the effects of drug-induced, addiction-related behaviour in the hippocampus. The main aim of this experiment was therefore to demonstrate the formation of a place preference to morphine, the expression of which must depend on the formation of drug-environment associations.

The CPP paradigm is perhaps the most widely used model of drug seeking behaviour in use today. Despite its popularity, consensus is yet to be reached regarding what particular behavioural construct of addiction it actually measures (Bardo and Bevins, 2000). As previously discussed, rodent models of a complex human behaviour such as drug addiction are likely never to be wholly adequate representations of the condition. Particular isolated aspects of the behaviour (constructs) are therefore often modelled in rodents in an attempt to produce relatively simple, reproducible tests with predictive validity in humans. Whatever particular behavioural construct CPP actually models, it has proven to be reliable in predicting the efficacy of several approved treatments for relapse prevention (such as naltrexone, a treatment approved for the treatment of opiate and alcohol

dependence). For an up to date overview of the successes of CPP in this context see Napier *et al.* 2013.

There exists some subtle differences between reported CPP methods in this study and those used by other laboratories, generally each laboratory has its own optimal conditions for demonstrating CPP. The most obvious division in the choice of apparatus is that between two and three chamber designs. The three-chamber design, with a small middle chamber that is paired to neither the vehicle or drug, is perhaps the most commonly used apparatus in the literature for three main reasons. Firstly, it provides a start compartment for the pre and post-conditioning trials. This prevents the experimenter introducing bias into the experiment by placing the animal in either one of the conditioning compartments, a 'forced choice' (Parker, 1992). Secondly, it also allows for the control of any confounding novelty driven preference to the drug-paired environment. Scoles and Siegel (1986) first argued that a rodent's innate preference for a novel environment could be expressed in the post-conditioning trial, based on the assumption that a drug's effect was to attenuate the habituation to the drug-paired environment (Scoles and Siegel, 1986). This issue was largely addressed by Parker (1992) and is solved by the presence of a third compartment that the animal will have experienced in a drug free state only once (the same number of times that the drug-paired environment would have been experienced in a drug-free state). In this study, no significant changes in the time spent in the middle compartment was observed for any of the experimental groups, supporting the suggestion that under these conditions novelty was not a significant factor influencing CPP scores. Thirdly, the three chamber design allows for the dissociation between preference for the drug, and aversion for the vehicle. Any aversion for the vehicle would be presumably expressed equally between the middle and drug-paired compartments. The fact that no change in the time spent in the middle compartment was detected supports the conclusion that vehicle aversion was not a significant factor under these conditions (data not shown). The two chambered model does have advantages however, for instance there seems to be no standard way of dealing with the time spent in the third compartment (Cunningham *et al.* 2003). For the fEPSP recordings a three chambered design was used. After optimisation during preparation of the patch clamp experiments, the design was switched to a two chambered design. The reasons for this were due to both variability in the control

animals behaviour, and the simplicity of the analysis. The two chambered model may represent a simpler choice for the animal, particularly important when attempting to optimise the reproducibility of any such CPP experiment. The reasons underlying this change in experimental protocol are discussed in further detail in the Appendix (Section A.1).

Another important contrast in apparatus design is whether or not the subjects have any innate preference for one environment over the other. Apparatus that results in the expression of this innate preference for one particular environment (apparatus bias) is known as a biased design and has important implications for interpretation of the experiment. Biased designs were once the favoured method in CPP studies, although this has now become less popular (Schechter, 1998). Cunningham *et al.* (2003) did an extensive study on the role of apparatus bias on place conditioning in mice. They found that when using apparatus that resulted in strong initial preferences, then place preference was only expressed if the drug-paired compartment was assigned as the initially least preferred side (Cunningham *et al.* 2003). One possible criticism of the biased design is that it is possible that the apparent initial preference was in fact the expression of an aversion for the least preferred side. If this was the case, then any anxiolytic effect of conditioning could be interpreted as preference (Carr, 1989). In fact this conclusion had been reached in a very early paper investigating the effects of heroin on place preference (Schenk, 1985). Cunningham *et al.* (2003) argued this anxiolytic effect was unlikely to account for all the observed changes in their experiment, as exactly the same experimental method produced CPP in an unbiased apparatus. The exact same argument could be applied to the data presented here, the effectiveness of the protocol for inducing CPP in the two chambered design (Figure 4.1) validates the previously performed three chambered experiment (Figure 3.3). The three chambered apparatus was an innately biased apparatus, one side being black while the other was white. The demonstration of place preference was expressed as an increase in the preference score on the test day compared to the pre-conditioning preference score. While during initial optimisation of the experiment this biased method gave the largest effect, the mice did not actually show a absolute preference for the drug-paired compartment. Due to concerns over the validity of such a model (see Appendix Section A.1) an unbiased design was chosen during the second round of optimisation when the

patch clamp experiments were being set up. One rather surprising fact is that although generally more highly regarded, the unbiased design has no standard definition. It is often difficult to tell apart studies that use a truly unbiased apparatus and studies that use a biased apparatus combined with the counterbalanced selection of drug-paired contexts (often reported as unbiased). The way in which the data are presented often hides any initial apparatus bias, if present (Cunningham *et al.* 2003). In the two chambered design (Figure 4.1), no significant preference in the pre-test score was detected (defined according to their environmental cues) and can therefore be defined as truly non-biased.

The two chambered experiment (Figure 4.1) was truly non-biased, and the drug-paired compartment randomly split between the two environmental contexts. The development of preference therefore can only be due to the drug-context pairing or aversion to the vehicle, as these were the only constant factors across subjects. Aversion for the vehicle is indistinguishable from preference for the drug in the two chambered design. Using a three chambered design however, aversion for the vehicle may be expressed as an increase in both the drug-paired and neutral middle compartments. As already mentioned, no change in the amount of time spent in the middle compartment was observed in this design; therefore it is unlikely that exactly the same vehicle injections would cause an aversion in the two chambered design (Figure 4.1)

The induction and expression of CPP bears the hallmarks of a Pavlovian learning process, requiring temporal contiguity of the unconditioned and conditioned stimuli as well as being subject to latent inhibition (where familiarity with the CS attenuates the subsequent development of US-CS associations), extinction and recovery. There are significant differences between classical Pavlovian conditioning and CPP however. One such example is that the conditioned response (the approach behaviour underlying CPP) cannot be exhibited during conditioning due to the animal being confined to one particular compartment. Further support for the idea that CPP may be more complex than simple Pavlovian conditioning comes from the finding that restraining rats during conditioning does not prevent the induction of CPP (Carr *et al.* 1988). CPP is therefore not predicted by the model of primary Pavlovian conditioning. Bardo and Bevins (2000) attempted to address this and other issues surrounding CPP, concluding that it

may be the expression of second order Pavlovian conditioning. As already mentioned in the Introduction, second order Pavlovian conditioning is where a normally neutral stimulus (CS) acquires the reinforcing properties of an unconditioned stimulus (US) through repeated contiguous pairings. In the case of CPP, the CS is presumed to be the features unique to (or context of) the drug-paired side of the CPP apparatus. A significant prediction of this hypothesis is that an increase in the probability of behaviour(s) underlying CPP would be seen during the test session, due to the reinforcement of the preference behaviour by the drug-paired context (secondary reinforcement). To the author's knowledge, four studies have addressed this issue (Bardo *et al.* 1984; Bozarth 1987; Mueller and Stewart, 2000; German and Fields, 2006) however none of these studies found any evidence that preference increases as the test session continues. In support of these findings, there was no apparent difference in subject behaviour during the initial or final 15 minutes of the test session in this study (data not shown).

A popular hypothesis is that CPP may be the expression of a conditioned approach response (CR) learnt through primary Pavlovian learning processes, similar to so called auto-shaping (Robbins and Everitt, 2002). This hypothesis states that CPP is the result of context-reward associations (presumably learnt through primary Pavlovian conditioning) influencing some sort of other exploratory behaviour. German and Fields (2006) proposed that the expression of CPP was due to an increased probability of the subject (a rat in their case) choosing to enter the drug-paired context. They arrived at this hypothesis after measuring two major behavioural parameters in their model of CPP, visit duration and visit frequency. Firstly they observed that while mean visit duration in the morphine-paired environment did not increase, visit frequency did. Secondly, the visit duration distribution of the morphine-paired environment suggested a constant exit probability (an exponential decrease in frequency of increasing visit durations) rather than a change in intended visit duration (presumably resulting in shift in a Gaussian distribution of visit durations around the intended visit duration value). This result is important as it suggests that two separate processes could be at work in CPP, the learning of Pavlovian drug-context associations, and the expression of CPP through the influence of these learnt associations on natural exploratory behaviour.

Despite the unresolved theoretical issues surrounding CPP, there is general agreement that some form of Pavlovian learning of drug-context associations occurs during CPP. It could be expected therefore, that the hippocampus (generally regarded as the location for encoding aspects of contextual and spatial information, as well as playing a wider role in the development of addiction-related behaviour) would play a role in CPP behaviours. Indeed lesions of the hippocampus can prevent the development of CPP (Ferbinteanu and McDonald, 2001), and the administration of morphine locally in to the hippocampus may even be sufficient to induce CPP (Corrigall and Linseman, 1988). Despite this fact, no demonstration of *functional* changes in hippocampal synaptic transmission after CPP have ever been published, these changes form the basis for the remaining discussion.

6.3 Effects of morphine treatment on fEPSP recordings

Extracellular field EPSP recordings (fEPSPs) revealed that non-contingent MOR treatment attenuated stimulus-induced LTP at Schaffer collateral-CA1 synapses (Figure 3.4). The effects of chronic morphine treatments on stimulus-induced LTP in CA1 have been addressed by numerous previous studies (Pu *et al.* 2002; Salmanzadeh *et al.* 2003; Bao *et al.* 2007, Lu *et al.* 2010; Xia *et al.* 2011). In many of these studies chronic courses of morphine impair the extent of any experimentally-induced LTP - in agreement with this study (although see Mansouri, 1999; Billa *et al.* 2010). The reasons given for this decrease in inducible LTP are varied. Pu *et al.* (2002) suggest that increased PKA activity in response to opiate withdrawal may over activate CaMKII (a key mediator of NMDAR-LTP, see Introduction), causing a saturation of LTP. This could result in an apparent decrease in inducible LTP. Bao *et al.* (2007) also conclude that this attenuation of induced LTP is due to PKA over activation. PKA overactivation is a hallmark of opiate withdrawal, produced by the result of a homeostatic response to the chronic inhibition of PKA by the $G_{i/o}$ coupled μ opioid receptor. In both these studies very intense courses of morphine treatment were utilised (18 injections of 10mg kg^{-1} , each injection separated by 12 hours, Bao *et al.* 2007; 20 injections of 10mg kg^{-1} , each injection separated by 12 hours, Pu *et al.* 2002). The authors make clear that they presume the observed effects are due to withdrawal. Although their observations are consistent with those of the present study, the morphine

treatments used here (2 injections of 10mg kg^{-1} , each injection separated by 48 hours and with preparation of slices performed at least 48 hours after the final morphine injection), are much less likely to induce dependence and withdrawal.

Lu *et al.* (2010) attempted to observe the effects of morphine treatment that were not due to withdrawal. They showed that increased extracellular adenosine induced by morphine treatment is not correlated with behavioural signs of withdrawal, and that re-exposure of brain slices to morphine does not reduce this adenosine concentration. However the injection paradigm they used (a total of 14 injections, injection interval 12 hours, dose increasing from 20 mg kg^{-1} on day one to 100 mg kg^{-1} on day 7) is not well suited to looking at effects of morphine independent from withdrawal. Despite this fact they propose that these increases in extracellular adenosine act to reduce stimulus-induced LTP through an A_1 receptor dependent mechanism. Adenosine A_1 receptors are expressed both pre and post synaptically in the hippocampus and reduce pre-synaptic transmitter release as well as inhibiting NMDAR currents. If the effects observed by Lu *et al.* (2010) were indeed the same as those seen in the present study, then both a reduction in transmitter release as well as a reduction in NMDAR-mediated current should have been observed in the patch clamp studies, indeed this hypothesis could fit the patch clamp data (discussed later, see Figures 4.2, 5.1 and 5.19).

Salmanzadeh *et al.* (2003) observed a slightly different effect of morphine to those papers already discussed (Lu, 2010; Bao, 2007; Pu, 2002). Slices taken from morphine treated animals showed an attenuated LTP when the slices were maintained in a solution containing morphine. Slices from naive animals kept in the same morphine solution exhibited normal LTP, as did slices from morphine treated animals kept in morphine free solution. There are a number of possible reasons for the differences between this study and those that have already been discussed (Lu, 2010; Bao, 2007; Pu, 2002). Firstly, Salmanzadeh *et al.* used morphine added to the drinking water, whereas all other studies mentioned (including the present one) used experimenter administered bolus injections of morphine. There are two possible interpretations of this difference. The first explanation is that while experimenter administered morphine represents a completely passive model of morphine administration (with no Pavlovian learning occurring), morphine added to

the drinking water could be seen as a model of non-operant self-administration. The second possibility is that while morphine added to the drinking water represents a passive model of morphine administration, experimenter administered morphine is actually a model of Pavlovian learning where certain elements of the protocol are learnt to predict the arrival of the morphine. There is evidence that experimenter administered morphine and morphine delivered by a computer controlled cannula (with no predictive cues) do in fact differentially affect AMPA:NMDA in the dopaminergic neurones of the ventral tegmental area (Chen *et al.* 2008). In this study, comparing the effects of an inappropriate vehicle control (SAL) to a model of drug-environment learning (MOR CPP) masked the attenuation in stimulus-induced LTP normally induced by morphine (see Figures 3.4 and 3.5). This result suggests that the combined effects of drug-environment learning and pharmacological actions of morphine could have combined in the Salmazadeh *et al.* study to mask each other. This argument could equally be applied to the findings of Billa *et al.* (2010a) although potential drug-predictive cues would be harder to identify.

An alternative explanation often given for contradictory results in experiments such as these is that the stimulation protocols used were different. The Salmazadeh study induced LTP using primed burst stimulation, an induction method that makes use of the oscillatory nature of hippocampal activity (see Introduction). If changes in GABA activity during morphine treatment were responsible for the reduction in stimulus-induced LTP seen in other studies, then the Salmazadeh study may not have detected those changes due to the GABA_B mediated auto-inhibition (none of the previous studies already discussed blocked GABA activity during LTP induction). In the present study, a theta burst induction protocol was used. This induction protocol also utilises GABA_B mediated auto-inhibition to increase the depolarisation of the post-synaptic neurone, although a reduction in stimulus-induced LTP was observed (Figure 3.4). This finding suggests that changes in GABA activity after morphine treatment were not responsible for these discrepancies.

6.4 Effects of morphine-induced CPP on fEPSP Recordings

MOR CPP induced no changes in stimulus-induced LTP that could not be explained by a combination of the effects of MOR treatment and the effects of SAL CPP treatment combined. The overall effect of *morphine* in MOR or MOR CPP treatment paradigms seemed to be indistinguishable - that is a attenuation in stimulus-induced LTP compared to appropriate vehicle controls (SAL or SAL CPP respectively Figure 3.7). The overall effect of exposure to the CPP apparatus appeared to be similar when comparing MOR to MOR CPP or SAL to SAL CPP - that is a augmentation in stimulus-induced LTP (Figure 3.7). The apparent lack of change when comparing SAL to MOR CPP therefore (as many studies do) may in reality be the effects of morphine and the separate effects of CPP training overlying and cancelling each other.

The observation that SAL CPP treatment appeared to cause an increase in the magnitude of stimulus-induced LTP that was roughly equal in size to the reduction seen in the MOR group was surprising. This was particularly surprising as the major predicted confounding factor in this kind of behavioural protocol was stress induced by the exposure of the mice to novel environments or the injection protocol. Stress has a well documented role in the impairment of hippocampal stimulus-induced LTP (for a review see Kumar, 2011). So to confirm this effect was not due to stress, naive mice having received no handling or behavioural interventions whatsoever were compared with mice that had received SAL treatment. As expected SAL treatment caused a small but not statistically significant decrease in the magnitude of stimulus-induced LTP. One possibility for this surprising result is that entry into the CPP apparatus could represent a form of environmental enrichment (EE). EE has been shown to reverse the impairment in stimulus-induced LTP (Solinas *et al.* 2010) as well as reducing the expression of CPP to cocaine or even extinguishing it (Chauvet *et al.* 2008). The results presented here suggest that although EE (the CPP protocol in this case) can apparently reverse the reduction in inducible LTP in the hippocampus, this is not correlated to any reduction in drug seeking behaviour (measured using the CPP model) as the MOR CPP group expressed preference for the drug-paired side.

One other interesting effect noted in the Results section was a large increase in variability of the data from both MOR CPP and SAL CPP groups (Figure 3.8). Based on the hypothesis that stimulus-induced LTP is reduced if LTP has already taken place at those synapses *in vivo*, it was reasoned that perhaps this variability represented different 'amounts' of learning (meaning perhaps the amount of inducible LTP in the slice was correlated somehow to how familiar the subject had become with the place preference apparatus). A correlation plot was therefore drawn comparing preference score and magnitude of inducible LTP (Figure 3.12) although no significant relationship was found. This result does not necessarily suggest that there is no correlation between learning and LTP however, perhaps just the method of measuring the learning (behaviourally) was incorrect. As a deeper analysis of individual behaviour was not performed, there remains the possibility that some aspect of a subject's behaviour would be predictive of the magnitude of inducible LTP. One interesting comparison that was not performed would be to compare the probability of drug-paired environment entry (as measured in German and Fields (2006)) with the magnitude of inducible LTP. Unfortunately this labour intensive analysis could not be performed due to time considerations. Another possible underlying cause of this increase in variability was the precise proximodistal/dorsoventral placement of the stimulating and recording electrodes. While every effort was made to standardise the placement of these electrodes some variability is unavoidable using current slicing and recording techniques. In a recent review Fanselow and Dong (2010) proposed the separation of each of the major hippocampal subfields (DG, CA3 and CA1) into three further structures, dorsal, intermediate and ventral for each subfield. This idea was based on the mounting behavioural and genetic data suggesting differences in these subfields along the dorsoventral axis. In the present study ventral hippocampal slices were prepared using a transverse slicing method, it was reasoned that the orientation of the dorsal hippocampus would prevent any slices being collected from this region. While this argument may be true, it is entirely possible that slices were collected from this intermediate zone as well as the ventral zone. The underlying cause of this variability therefore could be the fact that different dorsoventral portions of CA1 are affected differently by the CPP training, and that in this experiment the dorsoventral placement of electrodes was not sufficiently controlled. Regardless of the mechanism underlying this increased variability in the CPP groups, the fact that it was not unique to MOR CPP

suggested that this effect may not underlie the drug-induced behavioural adaptations seen in this group.

Deducing a mechanism for the observed adaptations induced by morphine (when using fEPSP measurements as the only electrophysiological measurement) is complicated due to the numerous possible interpretations of this result. For example, morphine appears to reduce stimulus-induced LTP. It could be suggested that the observed reduction in stimulus-induced LTP could be due to prior *in vivo* LTP as a result of the drug treatment. The observed changes then would therefore be due to a kind of 'ceiling effect'. This possibility (and others) was discussed previously in Section 3.3. One possible way to investigate this using fEPSP measurements would be by the analysis of input output curves, but this would require a high number of repeats as the signal to noise ratio of such experiments is generally small. Another possibility is that some kind of other adaptation occurs in response to the pharmacological actions of the drug, such as a reduction in mGluR activation, or changes in extracellular adenosine concentrations. This explanation would therefore be that morphine reduces 'meta-plasticity' in CA1 rather than inducing LTP itself. In an attempt to identify which of these scenarios was correct, and to further investigate the source of variation in both of the CPP groups, whole cell patch clamp was performed in the same hippocampal region using the same experimental groups.

6.5 AMPA:NMDA is increased by morphine treatment

The fEPSP recordings yielded two possible hypotheses surrounding the decrease in stimulus-induced LTP. The first was that prior *in vivo* LTP had occurred, the second was that metaplastic changes had occurred *in vivo* that affected subsequent *ex vivo* LTP (see Figure 3.16). In an attempt to further test these hypotheses whole cell patch clamp recordings were performed on individual hippocampal CA1 pyramidal cells whilst stimulating in the same location in the striatum radiatum. It was reasoned that if prior *in vivo* LTP had occurred (perhaps by NMDAR-LTP), then the ratio of current mediated by AMPARs should increase relative to the current mediated by NMDARs (as in Ungless *et al.* 2001). Indeed in this study, increased AMPA:NMDA in the non-contingent MOR group is consistent with the first hypothesis, that prior *in vivo* LTP had occurred (Figure 4.2). This

result comes with the caveat that if the decrease in stimulus-induced LTP was due to reduced NMDA then AMPA:NMDA could also have increased. Billa *et al.* (2010a) also studied the effects of experimenter administered morphine in CA1, using a combination of extracellular field recordings, patch clamp, and biochemical analysis. After repeated morphine administration they found increased AMPA:NMDA in agreement with this study (Billa *et al.* 2010). They also provided biochemical evidence to suggest that while AMPAR expression had increased, NMDAR expression remained unaffected. Therefore this study supports Billa *et al.*'s finding that experimenter administered morphine increases AMPA:NMDA through insertion of AMPARs in CA1 neurones, the extension of this argument is that *in vivo* an LTP-like mechanism occurs in response to the non-contingent morphine treatment.

In contrast to this study, Billa *et al.* (2010a) did not observe any reduction in inducible LTP using extracellular field recordings. One possible reason for this result is that the high frequency stimulation protocol used in their study induced LTP via a different initial mechanism to the theta type stimulation utilised in this study. Differing patterns of presynaptic activity would be expected to produce different amounts of glutamate release from the presynaptic cell and may therefore activate unique combinations of receptors by spill over mechanisms. One hypothetical example of this situation could be that high frequency stimulation such as that used in Billa *et al.* (2x100Hz pulses of one second each) could activate the extrasynaptic mGluRs on the post-synaptic cell. If this were the case then any treatment that reduced mGluR activation *in vivo* would not be detected as a reduction in inducible LTP (mGluR activation may act as a molecular switch facilitating the induction of LTP for several hours after activation, see Introduction for more details). If theta-type stimulation such as that used in this study was dependent on prior mGluR activation *in vivo* then using this method would reveal the difference. This would suggest that morphine had metaplastic effects alongside insertion of AMPARs.

Another possible way to reconcile these results is to assume that the injection paradigm used in Billa *et al.* (2010a) was in fact more akin to the MOR CPP group in this study. As the injection paradigm used did not include alternate saline injections, then many procedural aspects of the injection process will have been

predictive of imminent morphine reward, and therefore the effects of the drug may be confounded with the effects of reward related learning. This conclusion has been reached before, Chen *et al.* (2008) showed that cocaine induced increases in AMPA:NMDA in the VTA could be abolished by giving rats cocaine through a computerised cannula, rather than an experimenter administered ip injection. Comparing the SAL group (control) with the MOR CPP group (morphine plus a predictive cue) in this study would lead to the conclusion that morphine administration does not affect inducible LTP. In reality, the MOR CPP group result appears to be the combined effects of CPP (or in the case of Billa *et al.* some procedural aspect of the method) and MOR treatment (that does in fact attenuate inducible LTP in this study). This problem of separating pharmacological effects of a rewarding substance from unintended reward related learning (or more general learning as in the SAL CPP group) is common to many of the experimenter administered models in current literature. The results presented here suggest that the inclusion of alternate injections of saline may prevent procedural aspects of the method becoming predictive of reward, and therefore may prevent any adaptations related to learning.

Evidence for an increase in absolute AMPAR function (and therefore synaptic efficacy) following any kind of treatment is difficult to observe as the natural variability in the number of functional synaptic connections, along with variations in the angle of cut when making the brain slices mean that synaptic responses have a large variability in amplitude. This variability is one of the problems that the use of AMPA:NMDA attempts to solve, and while it allows for the identification of a functional change in synaptic composition, it does less to inform as to the nature of the change. Ungless *et al.* (2001) when studying the VTA showed that this increase in AMPA:NMDA was accompanied by an increase in AMPA-induced current when AMPA was bath applied to the whole cell. In the current study no change in AMPA-induced current could be observed between MOR and SAL groups (Figure 4.17), this is in agreement with the Billa *et al.* (2010a) study also. It is possible this result is a false negative, as the significant variability in the data means that any change would have to be large. Reasons for this variability could include the natural variability in neurone size as well changes in drug availability at the receptors due to the changes in location and orientation of recorded neurones within the slice. The variability as a result of differences in availability could be

accounted for by using a longer drug application time (to allow equilibrium to be reached), this was attempted but after 12 minutes the AMPA-induced current had not reached a steady state and so the experiment was not repeated (data not shown). Alternatively, an increase in AMPA:NMDA could simply represent a shift of AMPARs from extra-synaptic sites to synaptic ones (and possibly reduce the current induced by brief applications of AMPA) this could further increase the chances of such a false negative result. To address this problem the total synaptic current amplitude at -70mV (and at 70% of max response) was analysed. As input-output curves were generated at the beginning of each experiment, then total EPSC amplitude should be (theoretically) independent of stimulating electrode location. Therefore any increase in the mean value of EPSC amplitude could represent a greater number of synaptic AMPARs. Indeed the amplitude in MOR cells was significantly greater than the amplitude in SAL cells (Figure 4.9). One caveat of this measurement is that the number of AMPA receptors is dependent upon cell size (based on the assumption that a larger cell will have more synapses). In order to control for this possibility the amplitude of the EPSC can be divided by the measurement of whole cell capacitance. Whole cell capacitance arises as a result of the insulating properties of the lipid bilayer. The larger the cell surface area, the higher the capacitance. By normalising the results of the measured EPSC amplitudes by their respective whole cell capacitance the variability of cell size is controlled for, and the value becomes a measure of the density of synaptic AMPARs across the whole cell. After normalising by cell capacitance no significant difference in synaptic AMPAR density was observed (although the trend was still present, Figure 4.11). This suggests that an increase in the number of synapses (concurrent with an increase in cell size) was in fact responsible for the observed changes in EPSC amplitude between MOR and SAL. There appeared to be no correlation between cell size and AMPA:NMDA however, suggesting that the increase in AMPA:NMDA and the increase in EPSC amplitude were unrelated.

In the present study, while AMPA:NMDA were increased (Figure 4.2), no evidence was found for either a change in subunit composition and only limited evidence of an increased overall AMPA function (Figures 4.9 and 4.11). While the AMPA:NMDA result is in agreement with previous reports (Billa *et al.* 2010), the present study failed to find evidence of an increase in GluR2 lacking AMPA receptors. One

possible reason for these discrepant findings is again differences in dosing patterns. Comparisons across studies using morphine as the addictive substance are frustratingly difficult to make as all too often the high doses given in quick succession mean the effects of drug withdrawal are inseparable from pharmacological actions or experience-dependent adaptations. In the case of Billa *et al.* (2010a), a rebounding over activation of PKA could be expected to increase phosphorylation of GluR1 and the insertion of GluR2-lacking AMPARs (Colledge *et al.* 2000). This would still not explain the observed increase in AMPA:NMDA common to both this study and Billa *et al.* (2010a) however, and this hypothesis must be treated with caution given the limited evidence of μ opioid receptors in hippocampal CA1 cells (Arvidsson *et al.* 1995).

As this contradiction between this study and Billa *et al.* (2010a) was a little surprising, the possible reasons for a change in AMPA:NMDA were investigated using available literature. The possible reasons for an observed changes in AMPA:NMDA actually turn out to be many, as illustrated by the observations in other brain regions where measurements of AMPA:NMDA have been studied in more detail.

The first observation of an addictive substance inducing a change in AMPA:NMDA was observed in the ventral-tegmental area (VTA) by Ungless *et al.* (2001). In the Ungless *et al.* (2001) paper the authors acknowledge that an increase in AMPA:NMDA alone does not provide strong evidence of an LTP-like change, as this change in AMPA:NMDA could also be due to changes in NMDA-mediated currents. Along with an increase in AMPA:NMDA therefore, Ungless *et al.* (2001) showed an increase in mEPSC frequency and amplitude, as well as an increase in the current induced by exogenously applied AMPA. In the same study the authors also studied AMPA:NMDA in the hippocampus although no change was observed following a single injection of cocaine. This increase in AMPA:NMDA was also observed in a later study by Saal *et al.* (2003) where they also showed that addictive substances with varying mechanisms of action (including morphine) increased AMPA:NMDA in VTA neurones. The mechanism of this increase in AMPA:NMDA has been extensively studied and may involve the insertion of GluR2 lacking AMPARs (Dong *et al.* 2004, Engblom *et al.* 2008). This process has also been shown to be dependent upon both the NMDAR (Engblom *et al.* 2008; Zweifel

et al. 2008) and the D5 receptor (Argilli *et al.* 2008, Schilström *et al.* 2006). The necessary trigger for these adaptations seems to be the rise of dopamine within the VTA rather than any experience-dependent activity as *in vitro* application of cocaine on acute slices can also increase the AMPA:NMDA hours later (Argilli *et al.* 2008). The hippocampus receives a dopaminergic innervation from the VTA, and CA1 pyramidal neurones express D5 receptors and D1/5 activation can affect the induction of LTP and LTD in this area (Frey *et al.*, 1991; Huang and Kandel, 1995; Chen *et al.* 1996; Otmakhova and Lisman, 1996; Swanson-Park *et al.* 1999). Dopamine release as a result of the pharmacological actions of an addictive substance may therefore affect LTP induction in the hippocampus. The idea is a compelling one, and suggests a mechanism by which *in vivo* morphine could have differing and indirect effects on hippocampal transmission.

GluR2 lacking AMPARs are strongly inwardly rectifying, and so may contribute little to the AMPAR-mediated EPSC recorded at +40mV. Removal of NMDARs and insertion of calcium permeable AMPARs can have complex effects on the rules governing LTP induction in acute slices (Mameli *et al.* 2011), and could explain why researchers using different induction protocols see either an attenuation (Luu and Malenka, 2008) or augmentation (Liu *et al.* 2005) in inducible LTP. Although no evidence was found for a change in stoichiometry of AMPARs in this study, the data was far from conclusive. The data provided by Billa *et al.* (2010a) and Xia *et al.* (2011) suggest that GluR2 lacking AMPARs combined with differences in LTP induction protocol may have been responsible for the differences seen in stimulus-induced LTP. One expected effect of changes in the sub-unit composition of AMPA receptors would be alterations in the decay times of mEPSCs. This is due to the fact that GluR2 lacking AMPARs display altered channel kinetics, including faster gating and higher single channel conductance (Liu and Cull-Candy, 2002). No evidence of changes in decay time could be observed in response to MOR treatment however (Figure 5.25), suggesting that no change in sub-unit composition occurred (although see Panicker *et al.* 2008).

In the VTA there is also evidence that the insertion of AMPAR into the post-synaptic membrane is coupled with a removal of NMDAR. This removal of the NMDAR would obviously increase any AMPA:NMDA measurement, and has been suggested to be the major contributory factor in any increase in AMPA:NMDA

(Mameli *et al.* 2011). Although attempts were made to directly measure NMDA-mediated currents, seal instability at +40mV seemingly due to the presence of fluoride in the pipette solution prevented any consistent measurements.

In the nucleus accumbens the picture appears to be much more complex. This complexity may in part, be due to the nucleus accumbens actually being a collection of functionally distinct structures tightly packed into a small space. The majority of neurones in the NAc are inhibitory GABAergic neurones known as medium spiny neurones (MSNs). These MSNs can be divided into two classes based on their function and receptor expression profile. The 'direct pathway' supposedly involved in the selection and initiation of movement contains G_s-coupled D1 receptor expressing MSNs. The 'indirect pathway' is involved in the inhibition of movement and contains G_i-coupled D2 receptor expressing MSNs (Kreitzer and Malenka, 2008). As well as these two functionally distinct but physically intermingled pathways the NAc can be further divided into two sub-regions the 'shell' and 'core' that may also have functionally distinct roles. Unfortunately nearly all the available literature studying the electrophysiological changes in the NAc following exposure to drugs of abuse uses cocaine as the test substance. Therefore there is no way of knowing whether these effects are due to the specific pharmacological properties of cocaine - or whether this is a common mechanism shared by all addictive substances. Repeated cocaine administration initially causes a decrease in AMPA:NMDA in the NAc shell (Thomas *et al.* 2001). This decrease was initially thought to be due to an LTD-like process occurring on the PFC input synapses (Thomas *et al.* 2001; Kourrich *et al.* 2007) although more recent evidence suggests that this decrease may be due to the production of silent synapses (Huang *et al.* 2009). Silent synapses are synapses with functional NMDARs but very little or no AMPARs (Malenka and Bear, 2004). Acute cocaine administration is sufficient to increase dendritic spine density (Kolb *et al.* 2003) with more intense treatment regimens increasing the effect further. The hypothesis that this increase in spine density represents the formation of new synapses is supported by the finding that NR2B synaptic function is increased (Huang *et al.* 2009). NR2B containing NMDA receptors are often used as a marker for immature synapses (Sheng *et al.* 1994). To further complicate matters - in cocaine withdrawn rats, a decrease in AMPA:NMDA is also seen (Kourrich *et al.* 2007) however this

time the effect is likely due to internalisation of AMPA receptors (Boudreau *et al.* 2007).

The increase in spine density following cocaine treatment in the nucleus accumbens could help explain the increased cell capacitance and EPSP amplitude seen in MOR treated mice in the present study (Figures 4.7 and 4.9). Cells with increased dendritic arborations may also exhibit higher AMPA:NMDA values (Andrasfalvy & Magee, 2001). Therefore one possible explanation for the above data is that MOR treatment increases the number of dendritic arborations. Presumably this would be due to the formation of new synaptic contacts, and so slices from MOR treated mice could be predicted to have an increased mEPSC frequency. The result of this experiment turns out to not be clear due to concurrent alterations in paired pulse facilitation (discussed later). Another way of observing possible increases in dendritic branching and synapse formation (that is independent of changes in release probability) is by studying the rise times of mEPSCs. Increased rise times may be associated with increased synapse-soma distances and therefore be a measure of dendritic growth (Smith *et al.* 2003; Gonzales-Burgos *et al.* 2009). Indeed increased rise times were observed for mIPSCs (Figure 5.22) and the trend was the same although not statistically significant for mEPSCs (Figure 5.10, $P=0.1$). Taken together, these findings suggest that creation of new synapses, particularly at distal dendrites, may play a part in the observed effects of MOR treatment.

In summary then, the data shows AMPA:NMDA was increased in MOR compared to SAL. A detailed analysis of the literature reveals many possible mechanisms for increasing AMPA:NMDA but the precise mechanism at work here has not been conclusively identified. Regardless of the failure to find the precise mechanism for this increased AMPA:NMDA, this study provides good evidence that synaptic transmission in this region has been affected by morphine treatment. There also appears to be a related effect of MOR treatment in changing the cell morphology, this idea is supported by the increased whole cell capacitance, EPSC amplitude, and mIPSC rise times.

6.6 *Morphine-induced CPP has complex effects on AMPA:NMDA*

Although no significant effects of MOR CPP on mean AMPA:NMDA values were seen when compared to SAL CPP (Figure 4.2), there was a similar increasing trend following MOR CPP as seen in the MOR/SAL comparison. What was immediately obvious looking at the data however, was the large increase in variability seen in the MOR CPP group. Some of the recordings appear to have very large AMPA:NMDA values while the majority express values similar to SAL CPP. The fact that this increase in variability was not seen in the MOR group suggests that the effect seen could not be attributable to differences in the biochemical response to morphine among sub-populations of cells. This suggests that there exists a sub-population of cells in the hippocampus that respond differently to morphine-induced CPP. A hypothesis was put forward that if LTP was a cellular correlate of memory, and AMPA:NMDA was a correlate of LTP; then perhaps the value of AMPA:NMDA was somehow correlated to the 'strength' of the memory. It was thought that perhaps those mice that had formed a stronger memory of the CPP apparatus would perform better in the CPP test. A correlation was drawn between AMPA:NMDA values and preference score (Figure 4.4) but no significant effect was detected. In fact, where more than one AMPA:NMDA value was taken from the same mouse, there appeared to be no difference between intra- and inter-subject variability (data not shown). This suggests that the AMPA:NMDA values between cells in CA1 for a single subject had become more variable, and so any correlation between any behavioural trait and AMPA:NMDA would be highly unlikely. It was reasoned that if this increase in AMPA:NMDA was due to increased dendritic arborisation (as may be the case in the nucleus accumbens) or some other mechanism (such as a decrease in the number of synapses proximal to the soma), then it was possible that changes in specific cell parameters could correlate with increased AMPA:NMDA in the MOR CPP group.

In an attempt to look for any possible electrophysiological markers of those cells expressing high AMPA:NMDA values in the MOR CPP group, correlations were drawn for AMPA:NMDA values compared to each of the whole cell parameters measured. No correlations were observed between AMPA:NMDA and; the stimulus intensity required to elicit 75% EPSC (Figure 4.6), whole cell capacitance (Figure 4.8), and the amplitude of 75% EPSC (Figure 4.10). There was a correlation

however, between AMPA:NMDA in MOR CPP and the holding current at -70mV (Figure 4.13). Although this correlation was quite weak ($R^2=0.24$), it was reasonably significant ($P=0.02$, 95% confidence interval of $r = 0.08$ to 0.76). As mentioned in the results, holding current is determined by a function of both resting membrane potential and input resistance. This suggests that a small proportion of the variability seen in AMPA:NMDA was due to variation in cell size. This correlation was present across all treatment groups however, and there was no significant increase in variability seen in MOR CPP holding current values. This suggests that mechanisms other than changes in cell size were responsible for increasing the variability in the MOR CPP group.

MOR CPP treatment had complex effects on AMPA:NMDA, with some neurones appearing to display very high AMPA:NMDA values while others appeared to be unchanged compared to SAL CPP or SAL. Assuming Billa *et al.* (2010a) were in fact observing a model of drug-induced learning, one could suggest that the insertion of GluR2-lacking AMPARs may be responsible for this increase. None of the above experiments provided evidence to support this conclusion however, under these conditions at least.

It was not clear if this effect on AMPA:NMDA was the result of two overlapping processes, or if the different conditions experienced during morphine treatment induced a unique set of adaptations. At present the latter of these two explanations seems more likely as AMPA:NMDA values appeared to be unchanged in the SAL CPP group compared to SAL group. Again, no specific mechanism or electrophysiological marker unique to the adaptations seen in the MOR CPP group was identified, although in general it appeared that larger cells may express higher AMPA:NMDA values. This increase in AMPA:NMDA in larger cells has been previously reported (Andrasfalvy & Magee, 2001) and may represent a mechanism of distance-dependent scaling. Distance-dependent scaling is a mechanism that serves to balance the effects that proximal and distant EPSCs have over somatic membrane potential. One possibility therefore is that AMPA:NMDA could increase through increases in the relative amount of distal synapses (either the creation or destruction of synapses). The data presented here suggests that synapse creation could be the mechanism, as whole cell capacitance was increased in the MOR

group and input resistance appeared to decrease with increasing AMPA:NMDA across the groups.

A marker often used for the detection of newly created synapses is the NR2B subunit of the NMDAR, with smaller less stable synapses expressing greater levels of NR2B. As already mentioned in the introduction NMDA receptors consist of tetrameric assemblies of NR1 and NR2 subunits. The NR1 subunit is a constructive subunit that is required for functional NMDARs. The NR2 subunits (A-D) modulate the kinetics of the receptor. In the hippocampus NR2A and NR2B are the major subunit types, and the ratio NR2A:NR2B may modulate the induction of LTP (a metaplastic mechanism). It would be interesting to see if those cells expressing increased AMPA:NMDA also expressed greater sensitivity to NR2B subunit selective NMDAR antagonists, such as ifenprodil. It has already been demonstrated that NR2B expression is increased in the hippocampus after morphine-induced place preference but not after place preference induced by natural rewards such as novelty, social interaction or food (Ma *et al.* 2006). Ifenprodil has also been shown to be effective systemically in preventing the induction, expression and reinstatement of morphine-induced place preference (Ma *et al.* 2011). NR2B containing receptors have slower channel closing rates than NR2A containing NMDARs and therefore conduct more calcium per activation (Yashiro and Philpot, 2008). Lower NR2A:NR2B values may then lower the LTP induction threshold and provide a mechanism for the possible increase of *in vivo* LTP seen in both MOR and MOR CPP groups.

6.7 Glutamate release is reduced by MOR treatment

The paired pulse ratio, measured by comparing two stimulated EPSCs triggered in quick succession, is often used to give a measure of release probability in the pre-synaptic terminal (Stevens, 1999). Paired pulse ratios were significantly increased in the non-contingent MOR group compared to SAL but remained unchanged in MOR CPP compared to SAL CPP (Figure 5.1). An increase in paired pulse ratio is often interpreted as a reduction in the probability of neurotransmitter release (P_r) from the presynaptic terminal, although there are alternative ways of interpreting the data. One possible interpretation of these data (that also accounts for the increased AMPA:NMDA seen in MOR) would be that postsynaptic 'unsilencing' of

synapses (insertion of AMPARs into synapses where there was previously none) could reveal a previously undetected population of presynaptic terminals with low P_r values. A prediction of this hypothesis would be that the frequency of mEPSCs would increase, as this value is a function of P_r and the total number of synapses. mEPSC frequency was in fact decreased in MOR treated subjects (Figure 5.4), supporting the hypothesis that the increased paired pulse ratio seen in MOR was in fact due to a decrease in P_r . While initially this decrease in P_r in the MOR group (a LTD-like change) seemed at odds with the rise in AMPA:NMDA (a LTP-like change) this finding does have support from the literature. Xu *et al.* (2004) showed that following a chronic course of morphine (and naloxone-precipitated withdrawal) the activity of SNAP-25 was reduced. SNAP-25 is a key mediator of calcium-induced exocytosis and so neurotransmitter release would be predicted to be reduced. Marie-Claire *et al.* (2007) studied changes in gene expression after an extended CPP paradigm (training was 23 days long involving a total of 11 morphine injections). They found 13 different genes were differentially expressed in the hippocampus compared to saline controls, and one of their major conclusions was a reduction in neurotransmitter release.

As already mentioned in the introduction, the effects of *in vivo* morphine treatments on CA1 hippocampal neurones can be through network changes but also by morphine acting directly on the hippocampus through activation of μ -opioid receptors, although activation of other subtypes of receptors may play a role (Billa *et al.* 2010b). These $G_{i/o}$ coupled receptors are thought to be located presynaptically on inhibitory GABAergic terminals. The expected actions of morphine would therefore be an increase in glutamatergic transmission through disinhibition. This classical model of the acute actions of morphine could be applied to the findings in this study where changes were seen long after cessation of *in vivo* morphine treatments. This suggests that the prolonged reduction in transmitter release seen here following morphine treatment could be some sort of homeostatic mechanism, in response to the over-activation of CA1 neurones. A prediction of this hypothesis is that high levels of activity in CA1 would be predicted to also cause a shift in the threshold of LTP (metaplasticity) making LTP induction less likely. This argument is supported by data from this study (Figure 3.4) and others (Pu *et al.* 2002; Salmanzadeh *et al.* 2003; Bao *et al.* 2007, Lu *et al.* 2010; Xia *et al.* 2011). *In vivo* however, acute (or chronic) administrations of

morphine appear to reduce extracellular concentrations of glutamate measured by microdialysis (Guo *et al.* 2005). The actions of morphine may therefore be radically different *in vivo* compared to *in vitro*, this finding suggests caution must be exercised when attempting to predict the actions of a drug from *in vitro* studies.

6.8 *Glutamate release is unaffected by MOR CPP treatment*

The possible decrease in glutamate P_r discussed above was not present in comparisons between SAL CPP and MOR CPP (see Figures 5.1 and 5.5). This result is significant, as considered together with data from the AMPA:NMDA measurements (Figure 4.3) a unique set of adaptations is revealed. These effects appear not to be due to either the 'experience' of the CPP protocol or the pharmacological actions of morphine. Again, without identifying a specific mechanism for the reduction in transmitter release in the MOR group, it is difficult to say if the failure to detect a change in the MOR CPP group was down to two opposing processes cancelling each other out, or due to the CPP experience preventing the adaptations seen in MOR from occurring. A possible explanation for this effect emerges when considering the likely effects of the changes in AMPA:NMDA seen across the two groups.

Widespread increases in AMPA:NMDA (assuming they resulted from the insertion of AMPARs) would be expected to have a large excitatory effect on the CA1 network, and therefore could possibly induce some kind of homeostatic response. Isolated increases in AMPA:NMDA on the other hand, may not have such network wide effects on excitability, perhaps therefore not requiring the (most likely) heterosynaptic reduction in transmitter release seen in this study (Figures 5.1 and 5.7). One study already mentioned (Marie-Claire *et al.* 2007) also used the CPP paradigm to study the effects of morphine-induced behavioural adaptations, and their conclusion that transmitter release after CPP induced by morphine was reduced initially seems to contradict the findings presented here. Marie-Claire *et al.* (2007) studied changes in gene expression throughout the hippocampus however, and therefore their findings are open to a number of possible reconciling interpretations, the simplest being that transmitter release was affected at a different hippocampal synapse (the mossy fibre-CA3 synapse for example is well known to express a presynaptic form of plasticity). Another possibility is that

transmitter release was down regulated at the inhibitory synapses in CA1, and therefore not detected by this experiment.

To further investigate the possibility that GABAergic transmission could be reduced after morphine treatment, mIPSCs were also recorded. In both MOR and MOR CPP mIPSC frequency was reduced (Figures 5.16 and 5.17). This finding not only reconciles the Marie-Claire *et al.* (2007) findings with the present data but also suggests that the effect that they observed could be unrelated to the induction or expression of CPP. Rather a prolonged reduction in GABAergic P_r could result from *in vivo* administration of morphine regardless of context.

6.9 Summary of major findings

Before a further discussion of the likely implications of the observed changes, a brief summary of the major findings will be useful. The major aim of this work was to identify alterations in CA1 synaptic transmission that were related to morphine-induced behavioural adaptation in the CPP paradigm. In order to do this, the effects of morphine and exposure to the CPP apparatus needed to be controlled for. While the SAL CPP group controlled for the exposure of the animal to the CPP apparatus and methodological procedures, controlling for the effects of morphine administration is more complex. The comparison of effects between non-contingent SAL and non-contingent MOR and between SAL CPP and MOR CPP was an attempt to control for this variable. The previous paragraphs have dealt with the interpretation of the data and what kind of adaptations are likely to have occurred in response to the different treatments, they are summarised in the following table (Figure 6.1, next page).

Variable	SAL	MOR	SAL CPP	MOR CPP
Inducible LTP	0	-	+	0? (minus compared to SAL CPP)
AMPA:NMDA	0	+	0	+/? (cell-dependent)
EPSC Amplitude	0	+	0	0
Cell Capacitance	0	+	0	0
Paired Pulse Ratio	0	+	0	0
mEPSC frequency	0	-	0	0
mIPSC frequency	0	-	0	-
mIPSC rise time	0	+?	0	0

Figure 6.1 A table summarising major findings.

Pluses signify an increase, minuses a decrease. MOR treatment appeared to decrease inducible LTP, increase AMPA:NMDA, increase cell size, decrease glutamate P_r and decrease GABA P_r . MOR treatment also appeared to increase mIPSC rise times although more experiments would be needed to confirm this result (see Figure 5.22). MOR CPP treatment decreased inducible LTP, increased AMPA:NMDA in a subset of neurones and decreased GABA P_r .

The reduction in inducible LTP seen in both MOR and MOR CPP is likely to be due to a metaplastic effect rather than a ceiling effect, as it was also seen in MOR CPP (where only a minority of cells expressed increased AMPA:NMDA). This effect may not be related to the morphine-induced behavioural change measured in this experiment as it occurs regardless of context. Reliable increases in AMPA:NMDA were observed in the non-contingent MOR group but not in the MOR CPP group. AMPA:NMDA appeared to be highly increased only in a minority of cells in the MOR CPP group. This effect was unique to the MOR CPP group and therefore may represent one of the neuroadaptations that underlie morphine-induced behavioural change. The EPSC amplitude was increased in MOR suggesting that either the mechanism underlying this increase in AMPA:NMDA was due to the insertion of AMPARs, or that MOR treatment had increased cell size or morphology (and therefore the number or location of synapses). The data

from cell capacitance measurements suggested that this increase was due to an increase in cell size. Although mEPSC measurements disagreed with this interpretation, these data were made less compelling by concurrent increases in paired pulse ratios. None of these effects (increases in cell size, reductions in glutamate P_r) were seen in MOR CPP. The most likely explanation for this was that the administration of morphine in a specific context prevented these adaptations from occurring, perhaps due to the more specific potentiation of neurones within CA1 (seen in the AMPA:NMDA experiments). GABA P_r appeared to be reduced across both MOR and MOR CPP, suggesting the administration of morphine alone was responsible for this adaptation and therefore was probably not related to morphine-induced behavioural change seen in the MOR CPP group.

6.10 Interpretation of results

As mentioned in the introduction the aim of this work was to identify changes in synaptic transmission related to drug-induced behavioural adaptations. The results discussed above reveal a picture of complex and unique adaptations that occur after morphine-induced place preference. These adaptations in synaptic transmission appear not to just be a combination of SAL CPP and MOR treatment suggesting that they may underlie the behavioural adaptations that occur uniquely after MOR CPP treatment. One of the major criticisms that can be levelled at previous published work is the failure to correctly control for both the 'drug experience' as well as procedural aspects of the CPP procedure. The 'drug experience' control is critical as not only are *in vivo* effects of a drug often vastly different to those of *in vitro* applications, but there are also undoubtedly learning processes that occur purely as a result of the conscious experience of a morphine-induced euphoria (assuming rodents do indeed experience such things). An example of the importance of including 'experience' controls can be seen when considering the effects of MOR CPP on glutamate P_r . While comparing SAL CPP to MOR CPP reveals no change in P_r , when considered together with the fact that normally morphine induces a reduction in P_r , this absence of a change becomes significant. This effect would not be detected without these 'experience' controls. It is not clear if this change in P_r occurs as a result of re-exposure to the drug-paired environment (during the test session) or if this adaptation in the MOR group is a result of the unpredictable administration of drug (presumably developing during

the injections). A way of investigating this effect would be to add a further treatment group that underwent MOR CPP training but were killed immediately *before* the CPP test. The addition of this treatment group would be useful for the study of all observed changes in synaptic function and could potentially identify changes that precede the induction of drug seeking behaviours.

While Table 6.1 summarises the adaptations that occur in response to MOR CPP treatment, it makes no predictions as to the implications of such changes. One hypothesis is that the neurones with high AMPA:NMDA represent part of the memory trace encoding the availability of drugs in one particular place. Place cells within CA1 have already been discussed in the Introduction (section 1.5.3.2), and there is limited evidence that their firing may be modulated by motivational factors (Moita *et al.* 2004; Hollup *et al.* 2001). It is possible therefore that these highly potentiated neurones detected are the place cells encoding the location of the morphine paired side of the CPP apparatus. Place cells increase their firing rate when the animal enters a specific location in an environment. The large dopamine signal resulting from the actions of morphine in the VTA would be expected to facilitate the induction of LTP in the hippocampus (as discussed in the Introduction). So assuming the mice had 'remembered' that the morphine paired environment was in fact only one half of a two chambered environment, then perhaps LTP was over induced in those place cells encoding the morphine paired environment. This hypothesis explains the widespread potentiation seen in the MOR group as during home cage injections the subject would have roamed throughout his environment, potentiating all place cells equally.

An alternative hypothesis, not mutually exclusive from the previous one, considers a different function of the hippocampus. As already mentioned in the Introduction the hippocampus has extensive efferent connections to the nucleus accumbens, and may help select appropriate behaviours depending on previous experience in similar contexts (Sesack and Grace, 2010). The multimodal sensory inputs may combine with previous memory traces in the hippocampus to produce a readout to the nucleus accumbens that induces appropriate behavioural responses. The normal physiological function of this system could be (for example) the selection of either food or copulation seeking behaviours depending on the previous experience in similar contexts. It is tempting to speculate that the highly

potentiated neurones seen within the MOR CPP group combined with the reduced flexibility (LTP) seen in both MOR and MOR CPP could result in very different sensory inputs ending in excitation of the same highly potentiated neurones. Perhaps this mechanism could result in a 'drugs available' signal from the hippocampus in many different and inappropriate contexts. This could explain the gradual spread of drug seeking behaviours in different contexts that occurs during the development of addiction. This hypothesis could also explain the somewhat surprising results from Vorel *et al.* (2001) where non-specific electrical stimulation of the hippocampus appeared to produce a coherent signal within the animal that induced drug-seeking behaviours.

6.11 Suggestions for further work and conclusion

The most obvious target for further research would be to investigate the neurones expressing high AMPA:NMDA in the MOR CPP group. Not only does the nature of the change need to be further investigated but also the mechanism(s) that leads to specific neurones being affected. Koya *et al.* (2012) used a fluorescent form of the neuronal activity marker, Fos, to identify a sub-population of neurones within the nucleus accumbens that were strongly activated in response to context-specific cocaine sensitization and found profoundly different patterns of cocaine-induced changes in AMPA:NMDA and probability of transmitter release between those neurones that were activated by cocaine treatment (Fos-positive) and those that are not (Fos-negative). It would be useful to develop a similar such technique to identify those neurones expressing high AMPA:NMDA in the hippocampus. This would be particularly useful in an area such as the hippocampus with such well defined and highly organised topography, as even basic visualisation could give an insight into the function/connectivity of these neurones. Furthermore, the mechanism(s) responsible for increasing AMPA:NMDA would be much easier to study if patch-clamp targets could be identified prior to recordings being made.

An alternative but similar approach follows a recent paper identifying sub-populations of CA1 pyramidal neurones (Graves *et al.*, 2012). In that study, two distinct sub-populations of CA1 pyramidal neurones, co-existing within the same sub-region of the hippocampus, were identified based on different electrophysiological and pharmacological characteristics and were also shown to

project to distinct brain regions, and to receive afferent input from distinct brain regions. Future work could be designed to investigate whether morphine CPP-dependent changes in synaptic plasticity at CA1 neurones are specific to one cell type.

Related to this there is evidence that the dorsal and ventral hippocampus are different both in terms of input and output and their physiological functions. The present study concentrated on investigating the ventral hippocampus but it would be interesting to also study possible changes in the dorsal hippocampus. In a similar vein, it would also be interesting the study synaptic modifications both up and down stream of CA1 (CA3 and the ventral subiculum respectively) to create a wider picture of how hippocampal processing is affected by MOR CPP treatment.

Another important question arising from these results relates to the timing of these changes. Some of these changes appear to occur after morphine administration, increases in AMPA:NMDA for example also occur in the MOR group. It is therefore likely that those mechanisms occur sometime during or after the morphine administration (although their precise nature or location may be context specific). Other changes however are less clear, specifically the change in glutamatergic P_r seen in MOR but not MOR CPP. It is hard to imagine that following the first administration of morphine different mechanisms are induced, as neither of the environments are novel or at that stage predictive of morphine reward. Therefore perhaps this P_r reduction occurs immediately prior or following the CPP test session. This suggests that this adaptation could be a particularly suitable target for intervention and therefore may be one of the most significant results to come out of this work. It would also be interesting to see how these adaptations changed over extended periods of time, given the proposed time-limited nature of the hippocampus in memory storage and the long lasting behavioural effects of CPP training.

Finally, the overlying objective of this study was not to study the effects of morphine specifically, but to study more general reward related learning processes. An important next step in verifying these findings therefore would be to repeat these observations using both natural rewards and other addictive substances. The hope would be that other addictive substances with varying

mechanisms of action but not natural rewards would induce some of these identified changes. A further logical extension would also be to repeat these findings in other strains of mice and ultimately other species. While this work never attempted or even aspired to create a 'magic bullet' for the treatment of addiction, perhaps one of these changes does represent a 'magic target' that one day will be utilised.

In conclusion, this work provides a number of interesting and previously unobserved effects of both morphine and morphine related learning in the hippocampus of C57BL/6J mice. As with any scientific experiment many questions arise from this work that deserve further investigation in the hope of one day creating a specific and effective treatment for drug addiction.

Appendix

In this appendix are included some of the more significant technical issues encountered whilst developing methods for both the conditioned place preference experiments as well as the electrophysiology experiments.

A.1 Conditioned place preference experiments.

A.1.1 Introduction

The place conditioning paradigm is a widely used *in vivo* method of measuring the rewarding or aversive effects of psychoactive substances (Tzschentke, 1998). Place conditioning relies on second order Pavlovian conditioning whereby the conditioned stimulus acquires the salient properties of the unconditioned stimulus through repeated pairings. As mentioned in the Introduction there were a number of constraining factors leading to the choice of this animal model:

The behavioural model must involve the formation of drug-context associations. As this was the aim of the electrophysiological investigation.

The animals must be (relatively) young. Patch-clamp recordings are generally performed with slices taken from young animals. This is likely to be due to increases in connective tissue and other biochemical changes with age, as well as the enhanced speed of dissection and cooling of younger, smaller, brains (Gibb & Edwards, 1994). This makes experiments on older animals more challenging. Given the amount of time invested into each experimental subject before electrophysiology was performed it was important to maximise the chances of successful recordings being obtained.

The drug doses involved must be as low and as infrequent as possible. As one of the main aims of this work was to study the formation of drug-context associations any confounding factors such as drug withdrawal or the development of drug tolerance were to be avoided.

Initially the model was loosely based on that of Orsini *et al.* (2005). Orsini *et al.* (2005) had shown that the C57BL/6J strain of mouse was more sensitive to the

rewarding effects of morphine in a CPP model than the DBA/2 mouse strain. The conditioned place preference and the conditioned place aversion models are well documented to be influenced by genetic background (Cunningham *et al.* 1992; Semenova *et al.* 1995; Orsini *et al.* 2005). The C57BL/6J strain is generally found to be the most sensitive to the rewarding effects of morphine, and therefore was selected as the strain of choice.

There are three major methodological issues surrounding the design of conditioned place preference experiments:

Two vs. Three chambered design of conditioning environment. There are a number of theoretical and methodological issues involved in this choice.

The presence of apparatus bias in the place conditioning environment. The presence of apparatus bias can have an impact on the sensitivity of the experiment.

The biased/counterbalanced assignment of drug-paired zones. The presence of apparatus bias can determine if a counterbalanced protocol can be used.

The number of chambers in a place conditioning experiment has a significant effect on both technical and theoretical issues. A two-chambered design consists of just the drug-paired and saline-paired environment with a removable door directly connecting the two. A three-chambered design consists of the drug-paired and saline-paired environments connected via a smaller neutral compartment. Technically the two chambered design is preferred as this makes the analysis of time in each zone simple. Another advantage of the two chambered design is that it is relatively simple to avoid apparatus bias. The major theoretical criticism of the two chambered design is that during the test session the subject is forced to make the choice between the vehicle-paired compartment and the drug-paired compartment (Prus *et al.* 2009). This means that any aversion to the vehicle-paired environment is very difficult to control for. With a three chambered design however, the time spent in the middle compartment can be assessed. Another criticism levelled at the two chambered design is that if the drug treatment were to prevent the familiarisation of the drug-paired context; then novelty could confound

the results (as rodents are exploratory creatures). For these reasons a three chambered design was initially selected for the CPP experiments.

Apparatus bias describes the effects that different environmental contexts have on subject behaviour. For example, in rats (and most likely other rodents) a compartment with white walls is generally less preferable to a compartment exactly the same but with black walls (Roma and Riley, 2005). The presence of bias in the apparatus is to be avoided if possible due to a number of issues. Firstly, if the drug is paired to an initially preferred environment then CPP may be difficult to detect due to a ceiling effect. Secondly, any bias present may represent an aversion to one particular side. If this is true then any anxiolytic effect of the drug conditioning may increase the amount of time in the initially aversive compartment (Bardo and Bevins, 2000). This could have the effect of always either increasing or decreasing the value of the CPP. This is also true *vice versa* for anxiogenic treatments. At the very best this would have the effect of increasing the variability of the data (and therefore decreasing the power of subsequent statistical analysis). For these reasons the first objective was to develop three easily distinguishable environments that C57BL/6J mice did not show preference for (Figure A.1). The distinct environments were created by using various different floor textures (ranging from smooth plastic to stainless steel grid) and wall colours (white, grey, yellow and black).

The third important methodological issue was whether or not to assign the drug-paired compartments randomly or not (biased vs counterbalanced protocol). While this choice appears to matter little when there is no apparatus bias (Cunningham *et al.* 2003) if the apparatus is biased then there are a number of points to consider. When choosing drug-context pairings based on initial preferences, detection of CPP could be hindered if the drug-paired environment is initially strongly preferred due to ceiling effects (as well as regression to the mean in unbiased apparatus). If selecting the initially least preferred environment then any anxiogenic effects of drug treatment could be indistinguishable from the effects of CPP (as well as regression to the mean in unbiased apparatus). Using a pseudo-random assignment of compartments would control for these factors, but in biased apparatus this could increase variability to the extent the detection of CPP would

be occluded. As this apparatus was thought to be unbiased then a pseudo-random assignment of drug-paired compartments was initially used.

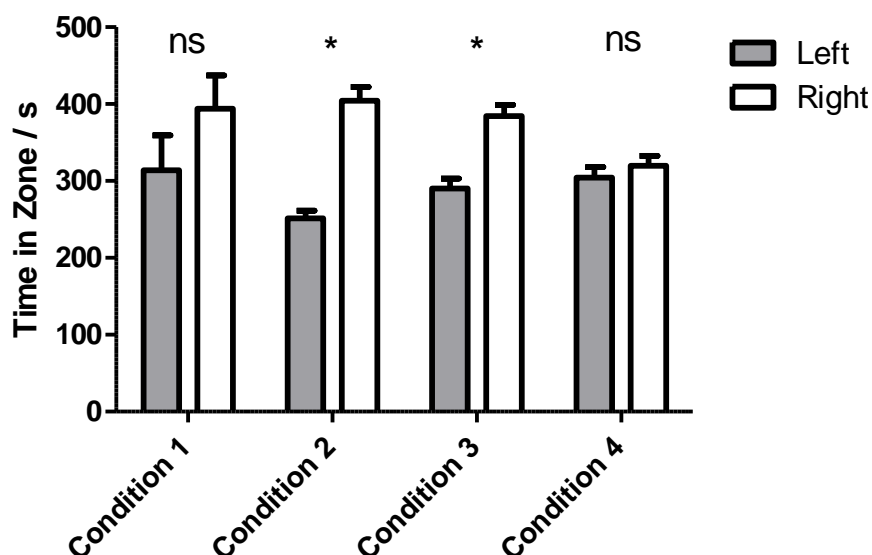

Figure A.1 The effects of different environmental contexts on subject preference.

The results from a single experiment using 24 x C57BL/6J mice (n=6 for each group). Mice were allowed to freely explore all compartments for 15 minutes and the total time spent in each compartment was recorded are presented as the mean +/- SEM. Stars indicate preference for one particular side over the other measured using a students' t-test. Each context differed from one another by different combinations of floor textures and wall colours in the same dimly lit room.

Figure A.1 gives an example of the effect changing floor textures and wall colours can have on initial preference during the CPP pre-test in a single experiment. From these experiments, the combination of walls and floors that made up condition 4 was selected.

A.1.2 Dose-response curve.

Although already reported by Orsini *et al.* (2005) and others, differences in subject age and contextual cues necessitated the dose-response relationship to be investigated. This was in order to achieve the demonstration of CPP whilst attempting to keep both the size and number of drug doses low, to avoid potential withdrawal effects. 23 x C57BL/6J mice were randomly assigned one of three doses of morphine (either 5, 10 or 20 mg kg⁻¹). Mice received two injections per day in a random order, one dose of morphine and one saline. This gave a total of 4 doses of morphine. As can be seen in Figure A.2, 10 mg kg⁻¹ appeared to be the lowest effective dose of morphine under these experimental conditions.

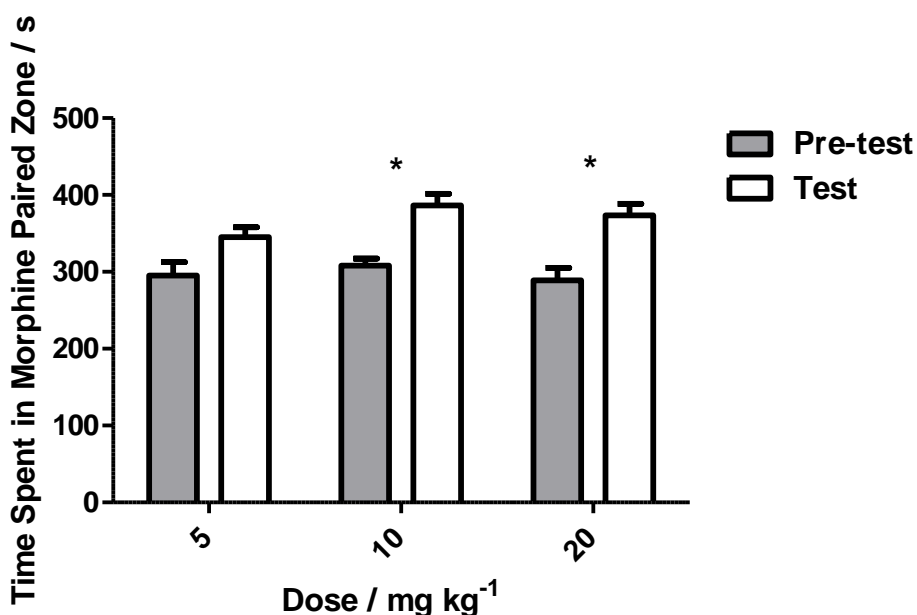

Figure A.2 A graph to show the effect of morphine dose on the detection of place preference.

23 x C57BL/6J mice were randomly split into one of three treatment groups to receive either 5, 10 or 20 mg kg⁻¹ morphine place conditioning. n=7-8 in each group, two-way ANOVA revealed a significant effect of training but not of dose. Stars indicate significant difference ($P < 0.05$) between time spent in the morphine paired zone on test day compared to pre-test result (Bonferroni post-test).

A.1.3 Single vs double injections

Again, to further minimise the issue of drug withdrawal more attempts were made to reduce the amount of drug given to each subject. 16 x C57BL/6J mice were randomly split into two groups to both receive CPP training using 10 mg kg⁻¹ morphine. One group (double injections) received two injections per day, one of saline and one of morphine (as above) giving a total of four morphine doses. The other group (single injections) had one injection per day (alternating between saline and morphine) giving a total of two morphine doses. The most obvious result of this experiment (Figure A.3) was that it failed to demonstrate significant CPP in either group (although the alternate injection paradigm group showed a trend in preference toward the morphine paired zone on the test day).

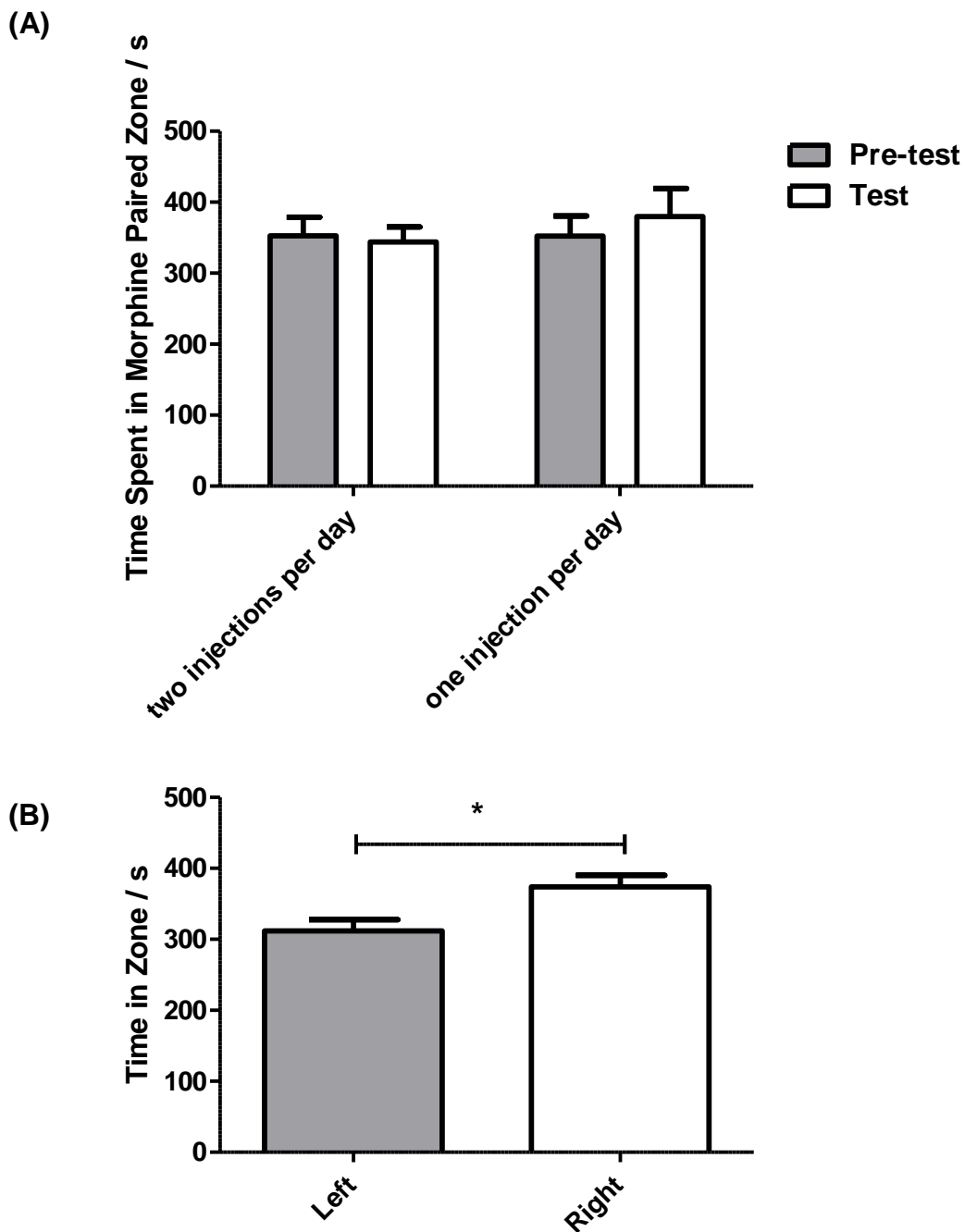

Figure A.3 The effects of different injection paradigms on the expression of place preference.

(A) 16 x C57BL/6J mice were randomly split into one of two injection paradigms, to receive either one or two injections per day. $n=8$ in each group, two-way ANOVA did not find any significant effect of training. (B) **Time spent in each of the two compartments during the pre-test session.** $n=16$ for each group, students' *t*-test revealed a significant preference for one side of the apparatus over the other (apparatus bias) ($P<0.01$)

A.1.4 Further environmental changes

Further analysis of the data from Figure A.3 revealed that a significant apparatus bias had developed (see Figure A.3, part B). Therefore further alterations in environmental context were performed and tested for preference. These experiments failed to produce a combination of environments that the mice preferred equally. A number of alterations were tested involving not only changes in tactile and visual cues but also involving smells and using masking (white) noise, an example of the data from one such experiment is given in Figure A.4. During this pre-test, masking smells and white noise were used. While this resulted in a balance of preferences, the environment was unsuitable as mice spent a large proportion of their time in the middle (smaller) compartment and were visibly stressed upon finishing the test

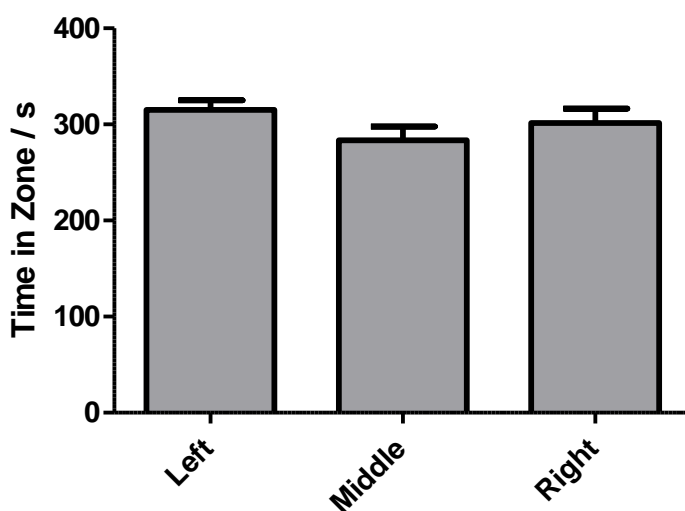

Figure A.4 Results of a pre-test during further environmental optimisation.

16 x C57BL/6J mice were allowed to freely explore the whole of the environment for 15 minutes while the total amount of time spent in each compartment was recorded.

A.1.5 The design of a biased experiment.

Overall, after testing a wide variety of different changes in environment it was not possible to change the environment in such a way that apparatus bias was reliably eliminated. Based on this failure, a biased protocol was developed. The biased paradigm in CPP experiments is widely used (although less so recently as it does

have a number of specific problems that were discussed earlier). Of concern in the results of Figure A.5 is the finding that conditioning in both the morphine and saline groups increases time spent in the particular environment assigned to be paired with morphine.

This makes it necessary to compare the behaviour of the morphine group against the saline control group. This can be done by generating a 'CPP score' that is equal to *time spent in the morphine paired zone on the test day minus time spent in the morphine paired zone on the pre-test day*. Comparing the CPP score of the morphine group with that of the saline group using a unpaired t-test results in no significant difference ($P=0.34$, data not shown), and therefore no significant measurable effect of morphine on conditioned place preference.

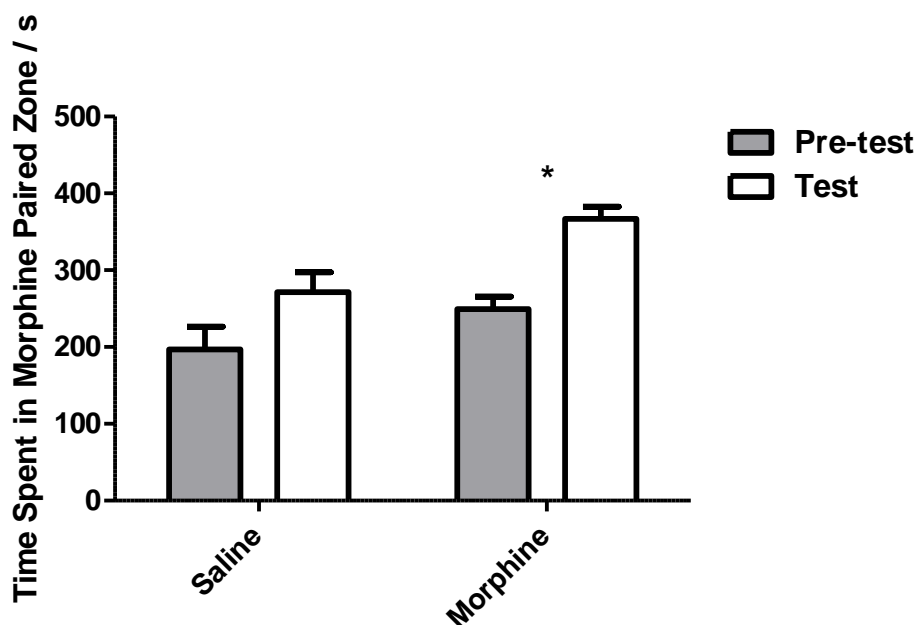

Figure A.5 An example of a biased morphine CPP experiment.

12 x C57BL/6J mice were randomly assigned to receive either saline or morphine place preference training (saline n=4, morphine n=8). The assignment of morphine paired zones was biased so that each mouse received morphine in its initially least preferred zone. A two-way ANOVA revealed a significant effect of both conditioning and drug with no interaction. Bonferroni post-tests revealed the MOR CPP group spent significantly longer in the morphine paired zone on the test day compared to the pre-test whereas the SALCPP group did not.

One possible reason for mice spending more time in the least preferred compartment after repeated saline treatments could be that habituation to an

initially aversive environment results in reduced aversion and so a shift toward this compartment on the test day. For this reason attempts were made to reduce possible sources of aversion from the environment whilst still keeping the zones distinct. One condition that was changed was to perform the same experiment as above but in red light rather than diffuse white light. This change resulted in visibly less stress for the animals something that is thought to impair the detection of CPP (Bechtholt *et al.* 2004). The most useful effect of using red light was in the behaviour of the saline controls. Under diffuse white light saline control subjects spend more time in the less preferred zone on the test day compared to the pre-test day (Figure A.6). Under red lighting however, zone preference does not change during conditioning and the animals displayed very consistent behaviour throughout the duration of the test. At this point it was decided that a robust conditioned place preference protocol had been designed.

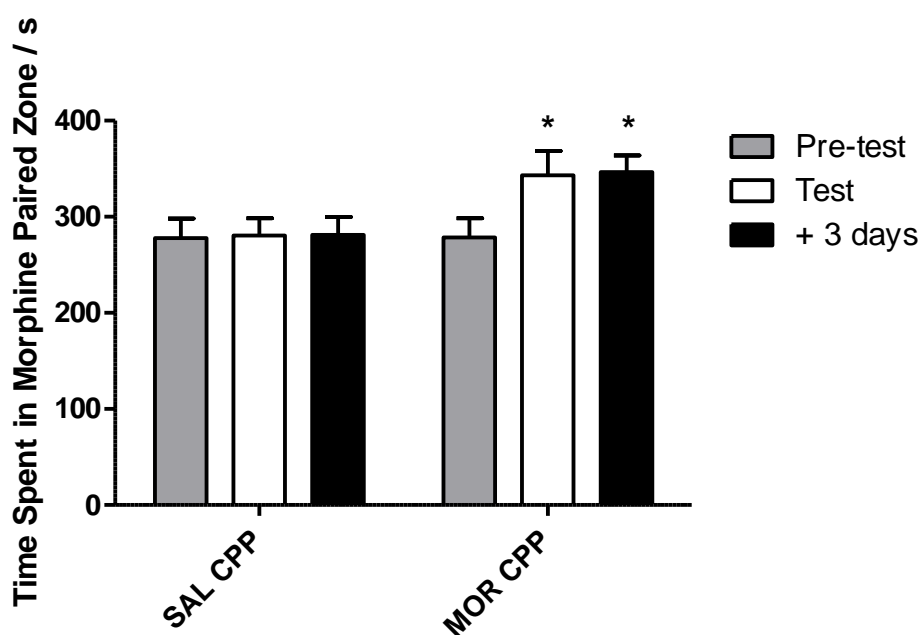

Figure A.6 Effects of red lighting on the behaviour of saline control CPP group.

While the animals were visibly less stressed at the end of each test session, the saline control group (n=8) also displayed very consistent behaviour compared to the saline control group in Figure A.5. A two-way ANOVA revealed effects of drug but not of conditioning. This allowed detection of changes in preference (by Bonferroni post tests) in the morphine group (n=8) unconfounded by the shift in preference of the controls. This effect was still present when re-tested 3 days later. Stars indicate $P < 0.05$ when compared to pre-test result.

A.1.6 Collection of fEPSP data

Having found a protocol that demonstrated robust morphine-induced CPP and had seemingly stable control behaviour, fEPSP recordings were collected whilst the protocol remained unchanged. The results of these numerous experiments are presented in the main results section (Chapter 3).

One flaw in the experimental design during this time was that saline control experiments were not performed along with the demonstration of morphine CPP. The reasons for this were that as the main aim of the study at this point was to investigate changes in synaptic plasticity in slices taken from animals that had been trained to exhibit morphine CPP, animal treatments were focussed on morphine CPP training rather than saline CPP training. Further, as CPP training takes 1 week per animal, in order to allow sufficient time for the electrophysiological investigation of each animal completing the CPP protocol (1 animal per day), subject numbers per experiment had to be kept low (n=4 per experiment, ie. n=4 trained per week). Given the natural variability present in *in vivo* experiments it is not possible to demonstrate CPP in each individual experiment (ie. n=2 saline-treated vs. n=2 morphine-treated per week). Therefore, at least initially, all behaviourally trained mice subsequently used for brain slice field recordings were trained to exhibit morphine-induced CPP. As can be seen in Figure A.7 (A) the MOR CPP group continued to show a increase in the amount of time spent in the morphine paired compartment. After sufficient data had been collected, these SAL CPP experiments were gradually reintroduced. At this time it became apparent that the behaviour of the SAL CPP treated subjects had changed. Collating data from both periods for the SAL CPP group resulted in the occlusion of any effect present in the MOR CPP group (Figure A.7 B)

As it was not possible to identify when this change in behaviour could have occurred, it was not possible to exclude specific fEPSP data without excluding it all.

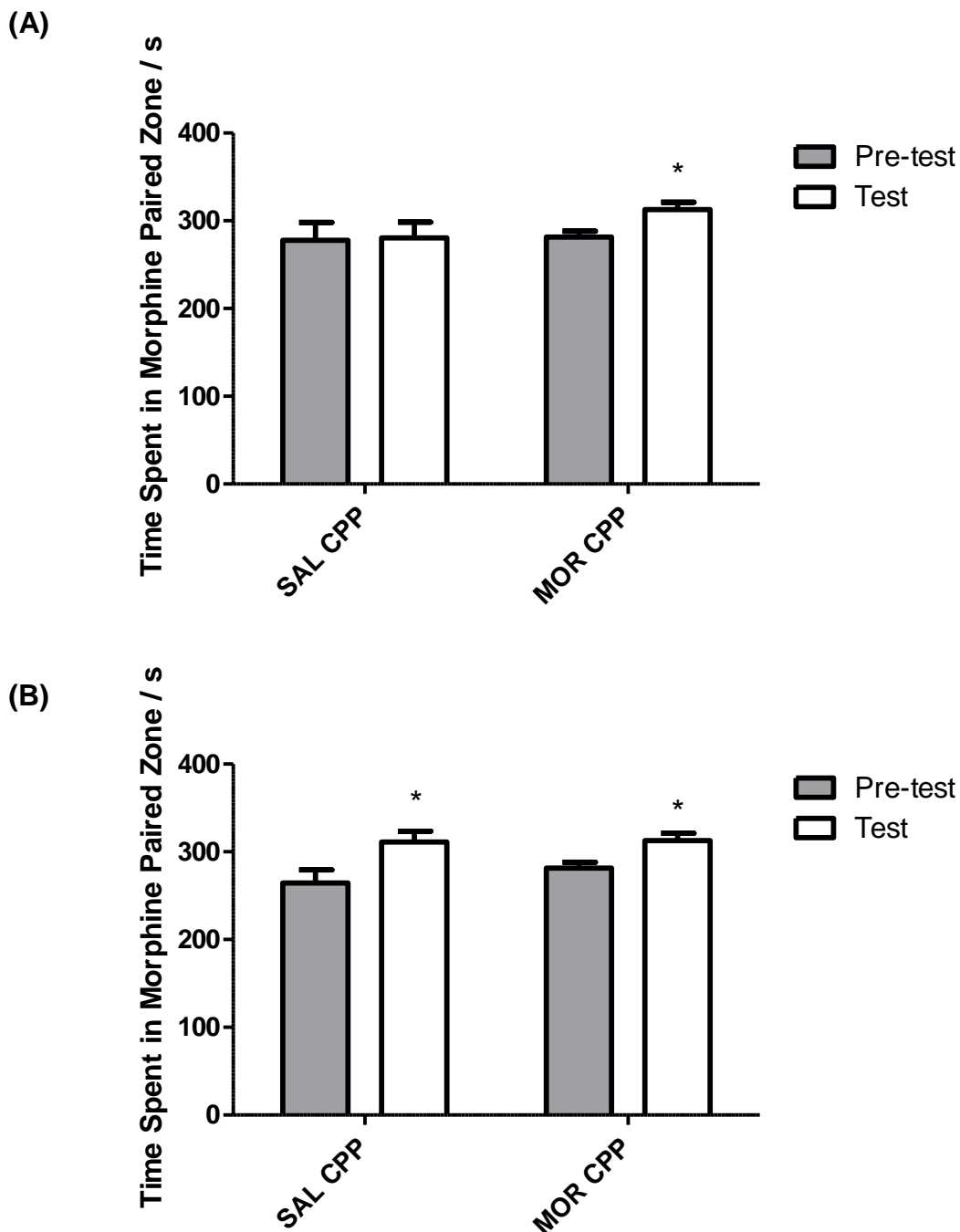

Figure A.7 Collated saline- and morphine-induced CPP data from the period over which fEPSP experiments were being performed.

(A) Comparing collated MOR CPP data ($n=50$) against saline controls performed at the start of the recording period ($n=8$) **(B)** Comparing collated MOR CPP data ($n=50$) against saline controls performed both at the start and toward the end of the recording period ($n=16$). All data analysed using a two-way ANOVAs with Bonferroni post-tests, stars indicate a significant difference in time spent in the morphine paired zone on the test day compared to pre-test day.

These results show that there was a consistent shift in preference toward the morphine paired environment in MOR CPP treated subjects (Figure A.7 A and B). In SAL CPP treated animals however, there was a change in behaviour at some point between the two recording periods. The effect of this change in behaviour was to mask any effect seen due to place preference in the MOR CPP group. It is impossible to tell from these results if this change in behaviour would have stopped the formation of drug-environment associations in the MOR CPP group.

The decision to include any fEPSP data in the main text therefore was based on the following reasoning. The objective of the CPP experiment was not to study the expression of CPP *per se*, but to demonstrate the formation of drug-context associations. During the conditioning process the effects of the drug could potentially be paired with many environmental cues related to conditioning methods. Therefore the absence of CPP during this time does not necessarily suggest the lack of any drug context associations. It is entirely possible that the chosen method of measurement simply failed to detect them. Cunningham *et al.* (2003) studied the effects of bias during the assignment of drug-paired zones in their place conditioning protocol. Using biased apparatus they demonstrated that CPP was only expressed in the group of subjects conditioned to their initially least preferred side; no apparent change of preference occurred in the group whose initially most preferred side was chosen as the drug-paired zone. Repeating their experiment in a *similar* environment (but crucially, one that did not display significant apparatus bias) resulted in mice displaying increased preference for the drug-paired zone regardless of initial preference. Since the same protocol in only slightly different environments resulted in CPP, they concluded that the failure to detect CPP in the biased apparatus (and conditioned to their most preferred zone) was due to a ceiling effect. In this experiment, the failure to demonstrate CPP (Figure A.7 B) occurred using the *same* protocol and environment that previously resulted in a detectable CPP (Figure A.5). Considering the Cunningham *et al.* (2003) argument therefore, could lead to the conclusion that the change in behaviour of the saline controls was masking the CPP likely to be present in the MOR CPP group. Secondly, there were consistent and significant differences seen in the field recording experiments (see Chapter 3) between the MOR CPP and SAL CPP treatment groups. This again suggests that different neuronal changes were taking place in mice that had undergone MOR CPP compared with SAL CPP.

A.1.7 Redesign of CPP paradigm

At the end of the fEPSP recording period the opportunity was taken to redesign the CPP paradigm to address some of the flaws present in the previous model. The major flaw identified above was that the demonstration of CPP was dependent on the behaviour of the SAL CPP group (due to the paradigm used), and that the behaviour of this group appeared to change over time. One way to overcome this problem is to use a counter-balanced design of experiment. In this method, equal amounts of animals are conditioned to each distinct environment (as opposed to the biased design used above where drug-conditioning is always to the initially least-preferred environment). Therefore, if innate preference to one particular environment develops over time, this would no longer have any effect on the post-test preference data, as this environment would be drug-paired in half of the animals and saline-paired the other half. Thus, any morphine-induced CPP seen in a counter-balanced experiment must represent drug-induced preference (Cunningham *et al.*, 2003).

At the same time the apparatus was changed from a three-chambered design to a two-chambered design, and the length of the pre-test and test trials was increased from 15 to 30 minutes.

The first stage in the development of the counter-balanced non-biased design was to create two equally preferred environments as was initially performed in Figure A.1, but this time continued monitoring of pre-test data confirmed no preference developed over time. The results of both the initial pre-test confirming the absence of apparatus bias (Figure A.7 A) as well as collated data taken over the whole period of patch clamp data collection (Figure A.7 B) are given in the figure below.

(A)

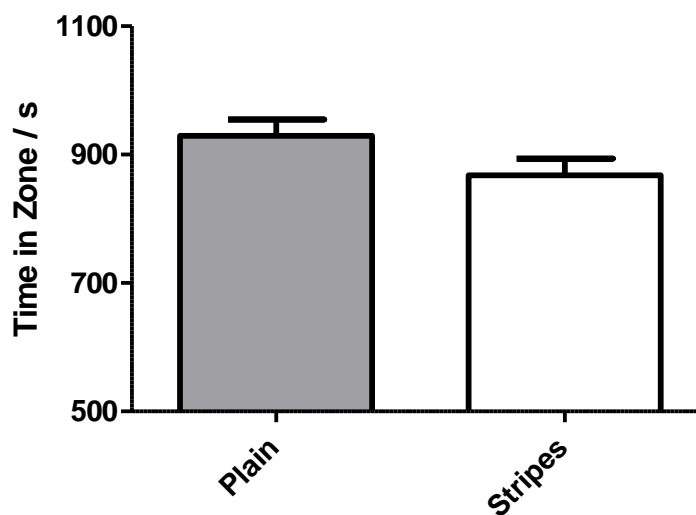

(B)

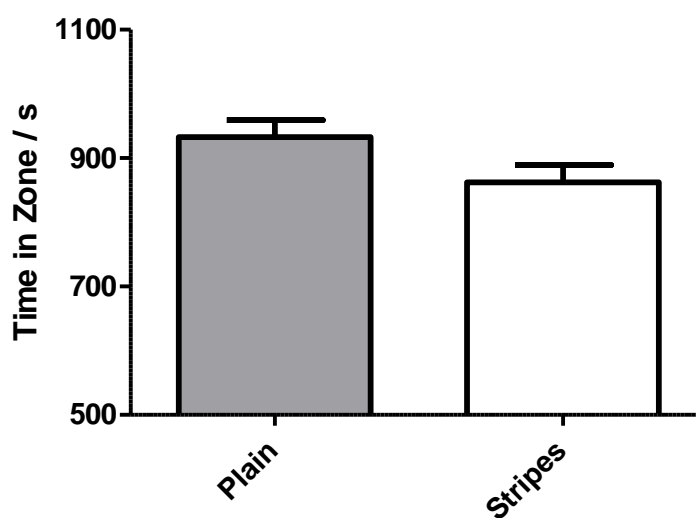

Figure A.8 Final environmental optimisation experiment comparing plain and stripy compartments.

(A) A paired *t*-test comparing the time spent in each compartment found no significant difference ($n=8$, $P=0.26$) **(B)** Collated pre-test data from the period over which patch clamp data was collected. A paired *t*-test comparing the time spent in each compartment found no significant difference ($n=28$, $P > 0.05$)

While the development of a counter-balanced design of CPP experiment negates the requirement for a saline CPP group, the electrophysiological experiments still required this. As can be seen in Figure A.9, as expected, saline-induced CPP was not seen, whereas there was robust and consistent morphine-induced CPP.

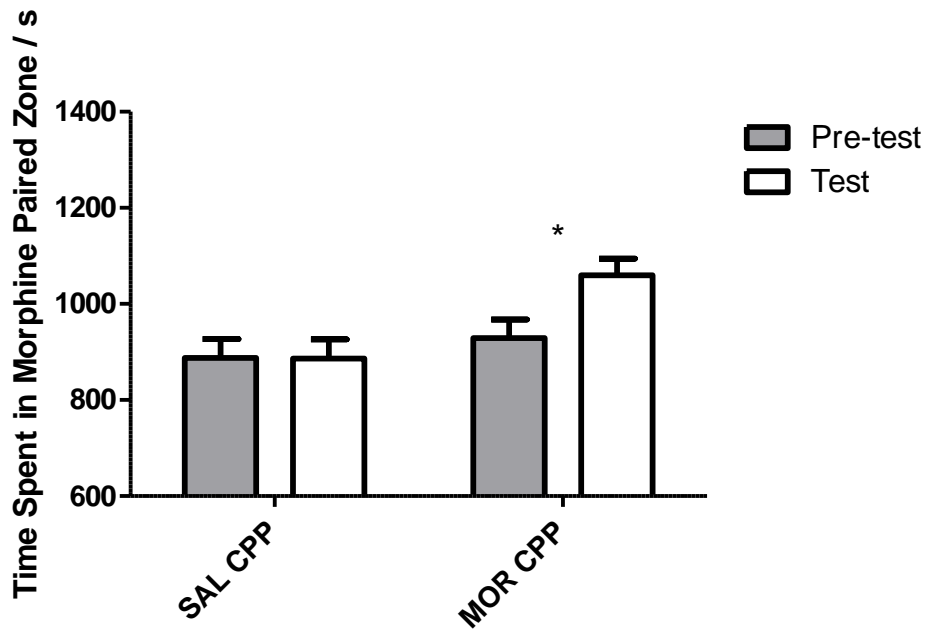

Figure A.9 Saline- and morphine-induced CPP during the period that the patch clamp data was being collected.

A two-way ANOVA revealed a significant effect of drug but not conditioning. It is highly unlikely that an effect of conditioning would be seen in a counterbalanced design of experiment such as this. Star indicates a significant difference in the time spent in the morphine paired zone on the test day compared to pre-test result (Bonferroni post test). This data was presented in a different for in Chapter 4 (Figure 4.1).

A.2 Optimisation of patch clamp methods

The main aim of the patch clamp electrophysiology experiments was to further investigate the functional changes in synaptic transmission that had been observed during the fEPSP recordings. A reduction in stimulus-induced LTP had been observed in response to morphine for both the non-contingent and place preference groups. It was reasoned that a reduction in stimulus-induced LTP could be due to either previous *in vivo* LTP induction or due to a reduction in metaplasticity. Each of these scenarios is presented graphically in Figure 3.16. As can be seen from the figure *in vivo* LTP (scenario 1) would have the result of increasing the value of AMPA:NMDA, as would a reduction in metaplasticity (scenario 2). Ungless *et al.* (2001) were the first to describe the change in AMPA:NMDA as a marker for previous *in vivo* LTP. Using 100 μ M picrotoxin to inhibit GABA_A mediated current Ungless *et al.* (2001) voltage clamped neurones at +40mV to relieve to magnesium block on NMDA channels (see Introduction). They then compared stimulated EPSCs in the presence and absence of 50 μ M D-APV. Using subtraction of the AMPA-mediated current from the compound AMPA/NMDA current allowed them to measure both the size of the AMPAR-mediated and NMDAR-mediated currents.

The Ungless *et al.* (2001) paper was chosen as a model in the development of the methods used in this study. A number of problems were encountered when attempting to measure AMPA:NMDA in this way - the most significant of these along with the solutions are described below.

A.2.1 Isolation of the compound AMPA/NMDA current

The first step was to confirm that that 100 μ M picrotoxin was indeed isolating the glutamate mediated current at -70mV. To achieve this, 10 minutes after the addition of 100 μ M picrotoxin, the 75% EPSC was measured. Then, 50 μ M D-APV with 50 μ M DNQX (an AMPA/Kainate antagonist) was added to the bathing solution and 10minutes later the 75% EPSC was once again measured (Figure A.10). Figure A.10 clearly shows a negligible EPSC following the addition of D-APV and DNQX suggesting that the observed EPSC at -70mV under these conditions was indeed mediated by glutamate.

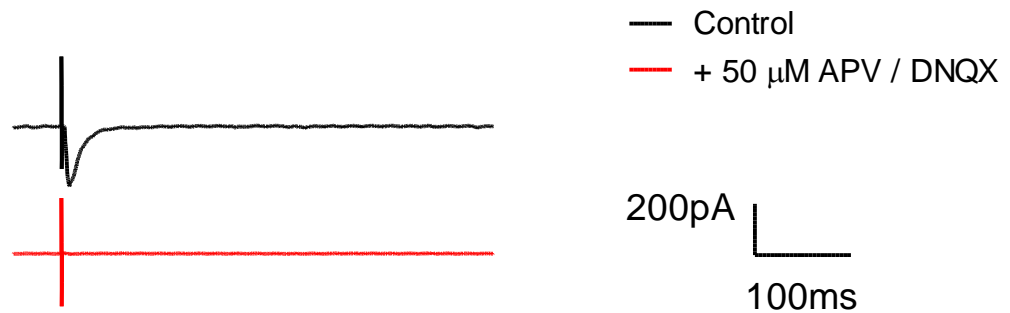

Figure A.10 The recorded EPSC at -70mV in the presence of $100\mu\text{M}$ picrotoxin is mediated largely by glutamate.

All recordings made in slices taken from naive C57BL/6J mice and stimulated to produce 75% of the maximum amplitude EPSC. Control (black) trace shows EPSC after the addition of $100\mu\text{M}$ picrotoxin, red trace shows the EPSC following the addition of the competitive antagonists D-APV and DNQX. This result suggests that the control (black) EPSC trace is mediated largely by glutamate.

Ungless *et al.* (2001) used $100\mu\text{M}$ picrotoxin in order to inhibit GABA_AR -mediated current. Perhaps due to differences in the functioning of local inhibitory (GABA) circuits between brain regions, $100\mu\text{M}$ picrotoxin appeared to (occasionally and unpredictably) cause a large, long-lasting inward current in response to sub-maximal stimulation. An example of this current is given below.

As can be clearly seen in figure A.11, the presence of this current occluded measurement of the AMPA/NMDA current. This problem, occurring only in around 5-10% of cells was initially ignored; cells displaying the current were excluded from analysis. Over time (days and weeks) however, the numbers of cells displaying this current increased (possibly due to the increasing health of the brain slices) until, before the method was changed, it was observed in 12 out of 21 recordings (>50%). Various approaches were taken to prevent the occurrence of this current, but efforts were largely unsuccessful. These approaches included; thorough dissection of CA1 from the surrounding tissue (following this, picrotoxin-induced current occurred in 5 out of 10 recordings), reducing stimulation intensity to 30% of maximal response (picrotoxin-induced current occurred in 6 out of 11 recordings), reducing the concentration of picrotoxin to $50\mu\text{M}$ (picrotoxin-induced current occurred in 3 out of 9 recordings), using bicuculline instead of picrotoxin as the

GABA_AR-antagonist (bicuculline-induced current occurred in 2 out of 2 recordings).

(A)

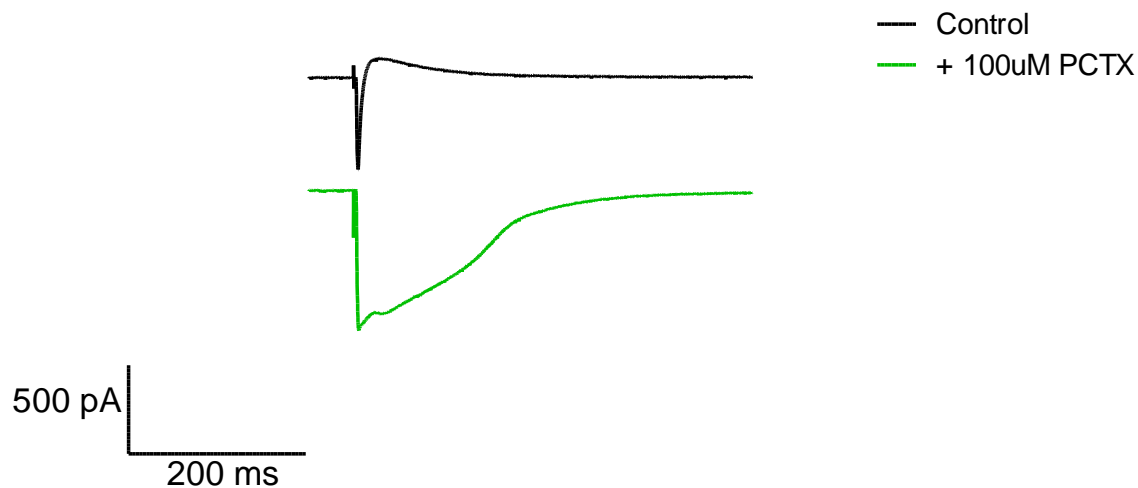

(B)

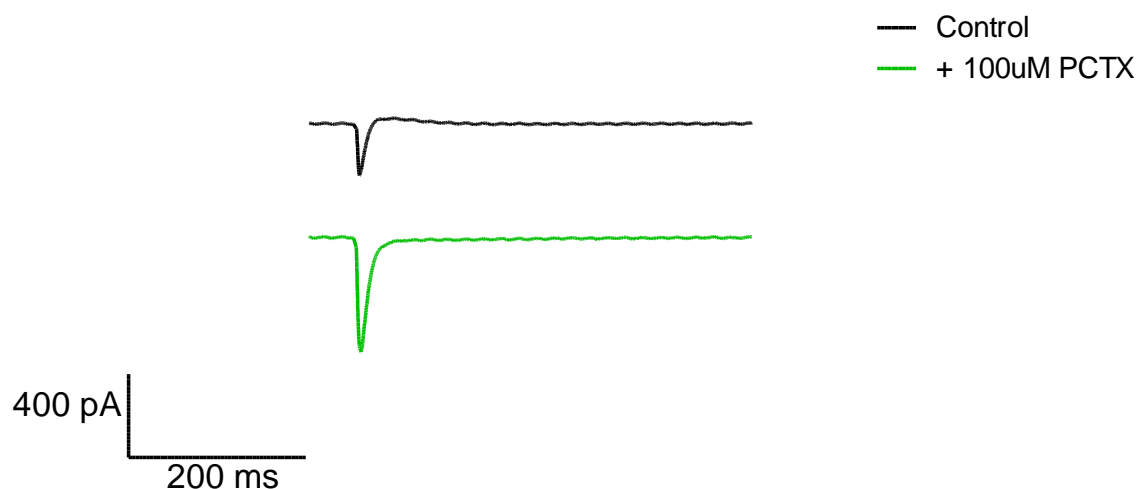

Figure A.11 Examples of variable effects of 100 μ M picrotoxin.

All recordings made in slices taken from naive C57BL/6J mice and stimulated to produce 50% of the maximum amplitude EPSC. (A) An example of the large inward current induced by stimulation in the presence of 100 μ M picrotoxin (B) An example of a recording performed under the same conditions where the large picrotoxin-induced current was not observed. The reasons for this variability were unidentified.

Extracellular block of GABA_A was more desirable than intracellular methods in this preparation as it was reasoned that local circuit GABA neurones contained within CA1 could potentially affect pre-synaptic glutamate release at the CA3-CA1 synapse. Therefore without extracellular GABA_A inhibition, any changes in this GABA modulation of glutamate release due to treatment could be indistinguishable from more direct effects on glutamate release. In order to address this argument, the effects of picrotoxin on paired pulse facilitation were examined (Figure A.12). As can be seen from Figure A.12 100µM picrotoxin caused a general decrease in paired pulse ratios when the inter-pulse interval was greater than 100ms. This result suggested that the paired pulse measurements taken at 50ms are independent of GABA activity. With this result in mind intracellular methods of inhibiting GABA_A were explored.

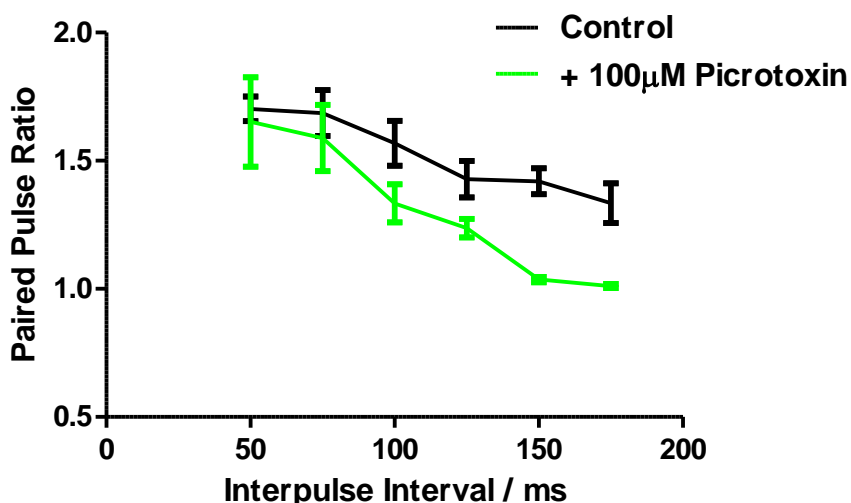

Figure A.12 Effects of 100µM picrotoxin on paired pulse ratios in slices taken from naive mice.

Paired pulse values at various inter-pulse intervals were first calculated, then 100 µM picrotoxin was added for 10 minutes before calculating paired pulse ratios one more. Data are presented as mean +/- SEM. A two-way ANOVA revealed a significant effect of both inter-pulse interval and drug, Bonferroni post-tests found a significant difference between paired pulse ratios in the absence or presence of 100 µM picrotoxin when measured with a 150 ms inter-pulse interval ($P < 0.05$).

Intracellular block of chloride conductance has also been demonstrated using picrotoxin in the intracellular solution (Akaike *et al.* 1985; Cupello *et al.* 1991; Inomata *et al.* 1998). In this preparation however, adding 50µM picrotoxin to the

intracellular solution appeared not to be effective within 30 minutes (data not shown). 4,4'-Dinitro-stilbene-2,2'-disulfonic acid (DNDS) has been shown to inhibit chloride conductance in cortical neurones (Dudek and Friedlander, 1996) therefore 500 μ M DNDS was added to the intracellular solution. To test for the effectiveness of the DNDS stimulated IPSPs were recorded at 0mV (close to the reversal potential for the AMPAR-mediated current). As can be seen in Figure A.13 (following page), stimulation whilst holding the membrane potential at 0mV results in a large hyperpolarising current (presumably an inward flow of chloride ions) that is completely inhibited by the addition of 50 μ M picrotoxin (part A). DNDS (500 μ M) failed to reduce 0mV current significantly (part B).

(A)

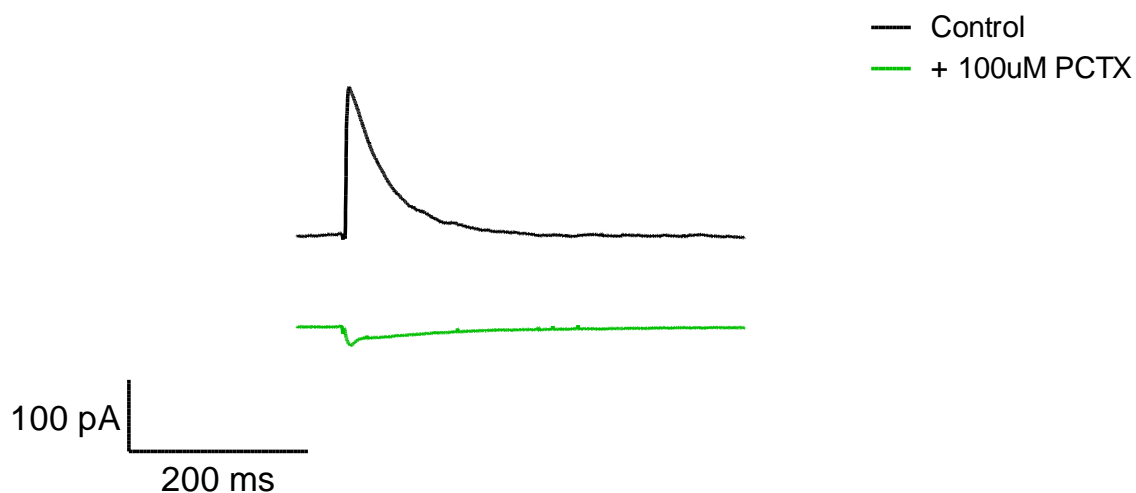

(B)

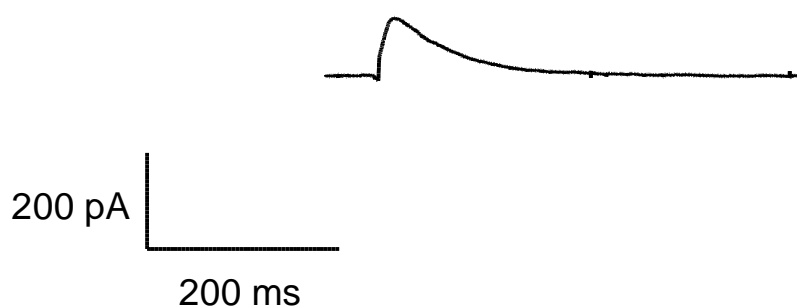
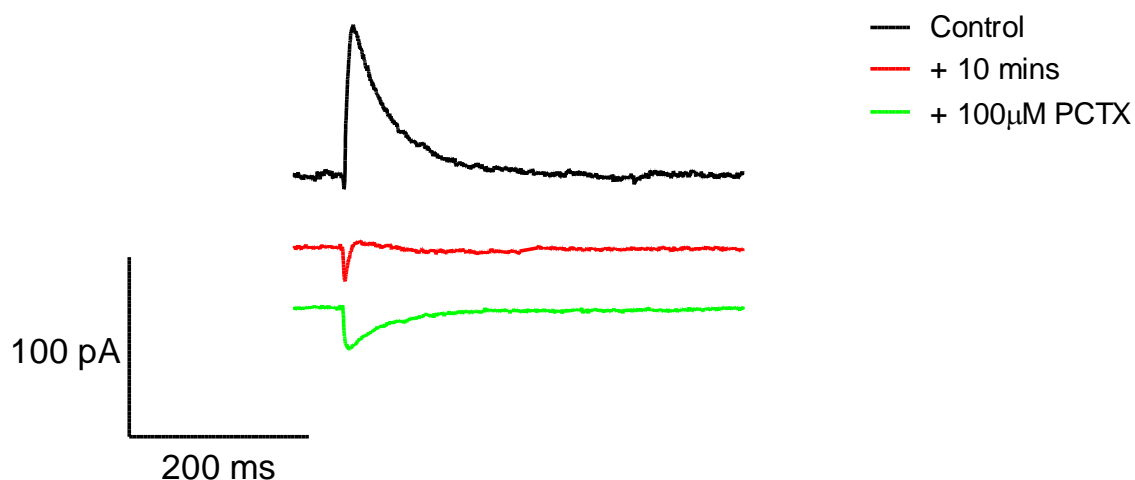

Figure A.13 500 μ M DNDS fails to completely inhibit the picrotoxin sensitive current.

All recordings made in slices taken from naive C57BL/6J mice and stimulated to produce 50% of the maximum amplitude EPSC. (A) Changing holding voltage to 0mV (approximate reversal potential for the AMPA-mediated current resulted in a large upward current (likely to be inward flow of chloride ions through the GABAA receptor, which was inhibited by addition of picrotoxin (100 μ M). (B) The IPSC recorded at 0mV approximately 20 minutes after breaking through into the cell with DNDS present in the patch solution.

Another reported method of blocking chloride conductance is the inclusion of fluoride ions in the intracellular solution (Kay, 1992). Replacement of half of the methanesulphonate ions with F^- ions appeared to result in complete inhibition of the IPSP recorded at 0mV within 10 minutes. Supporting this finding was the observation that the resulting current was not affected significantly by the subsequent addition of 50 μM picrotoxin (see Figure A.14). A significant disadvantage of using either DNDS or fluoride ions in the intracellular solution was that both the spermine and ATP/GTP appeared to precipitate out of the solution. Spermine is a polyamine compound that allows the inward rectification of GluR2 - lacking AMPARs to be observed (Isa *et al.* 1995). Removal of this compound therefore made it unlikely that changes in the sub-unit composition of AMPARs would be detected by measuring current-voltage relationships. ATP and GTP are necessary for many biochemical processes within neurones and therefore the major worry when removing these compounds would be that the functioning and/or health of the neurones could be significantly affected during the recordings. While this issue is difficult to resolve the stability of responses during a 60 minute recording was good.

(A)



(B)

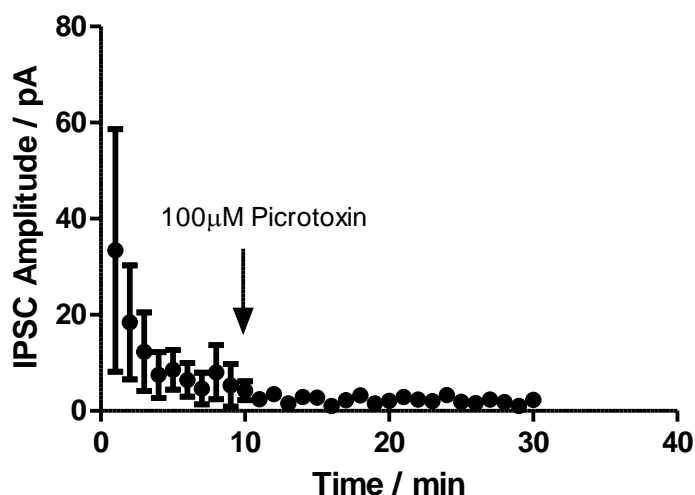

Figure A.14 The inclusion of fluoride ions into the pipette solution is effective in inhibiting IPSCs observed at 0mV.

(A) Results of a single experiment. The control trace (black) is taken immediately after breaking through and calculating a stimulus response curve, then 10 minutes later (red) at the same holding potential and stimulus intensity. The addition of 100 μ M picrotoxin resulted in a change in the kinetics of the revealed EPSC (possibly due to inhibition of pre-synaptic GABA_ARs) but had little effect on the IPSC **(B)** Averaged data ($n=3$) showing the effect of 100 μ M picrotoxin on the IPSP amplitude. All recordings made in slices taken from naive C57BL/6J mice and stimulated to produce 50% of the maximum amplitude EPSC.

A.2.2 Measurement of AMPA:NMDA values.

Ungless *et al.* (2001) used 50 μ M D-APV to inhibit the NMDAR-mediated current, and thus observe the AMPAR-mediated current. In this preparation however 50 μ M D-APV appeared to have unpredictable effects. The results ranged from where D-APV had a profound effect on the compound current, to no detectable effect. When D-APV appeared to have completely blocked NMDAR-mediated current (Figure A.14 C) the resulting analysis produced traces similar to those presented in Ungless *et al.* (2001). D-APV also produced traces that indicated that it had little or no effect however (see Figure A.14 A). The absence of any significant apparent NMDAR-mediated current in the thousands of synapses recorded from in a single cell was deemed unlikely. The ability of D-APV to inhibit the NMDAR-mediated current was therefore identified as the likely cause of variation. Different batch numbers of D-APV were ordered as well as D-APV from alternative suppliers, all with the same results.

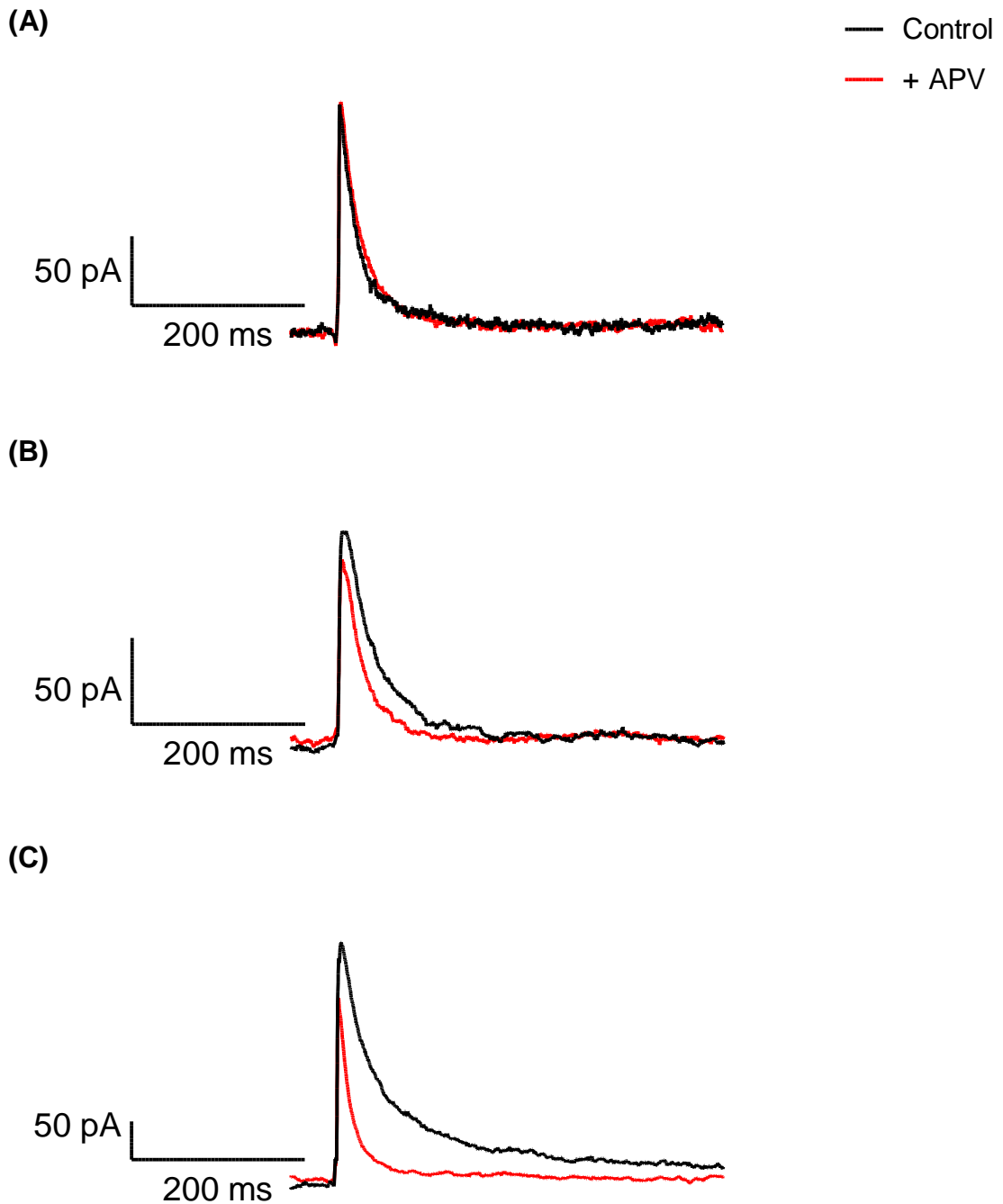

Figure A.15 50 μ M D-APV has variable effects on EPSCs in CA1 pyramidal neurones.

The result of adding 50 μ M D-APV to the ACSF from three separate experiments. The traces have been chosen to demonstrate the variability of D-APV ranging from no or little effect (A and B respectively) to significant inhibition (C). All recordings made in slices taken from naive C57BL/6J mice and stimulated to produce 50% of the maximum amplitude EPSC.

As an alternative approach, (+)MK-801 (a non-competitive use-dependent NMDAR antagonist) was also used. As MK-801 is use-dependent, a short 'induction' protocol (200 pulses delivered at 5Hz) was used 5 minutes after adding the antagonist to the ACSF. Although this protocol bears a resemblance to protocols used for the experimental induction of LTD, there are a number of reasons why this was predicted not to occur. Firstly LTD is dependent on a wide variety of signalling mechanisms - many of which require ATP or GTP, in this pipette solution ATP and GTP were excluded. MK-801 inhibits NMDA receptors, and current through these channels is a induction requirement of many LTD processes. In support of this argument was the observation that the AMPAR-mediated EPSC recorded at -70mV was unchanged 10 minutes after the 'induction' protocol (see Figure A.16). As with the D-APV experiments mentioned above MK-801 seemed to have variable effects on EPSPs recorded at +40mV, sometimes appearing to achieve near complete block of NMDA (giving sharp AMPA responses that decayed within approximately 50ms) to having much less of an effect (data not shown).

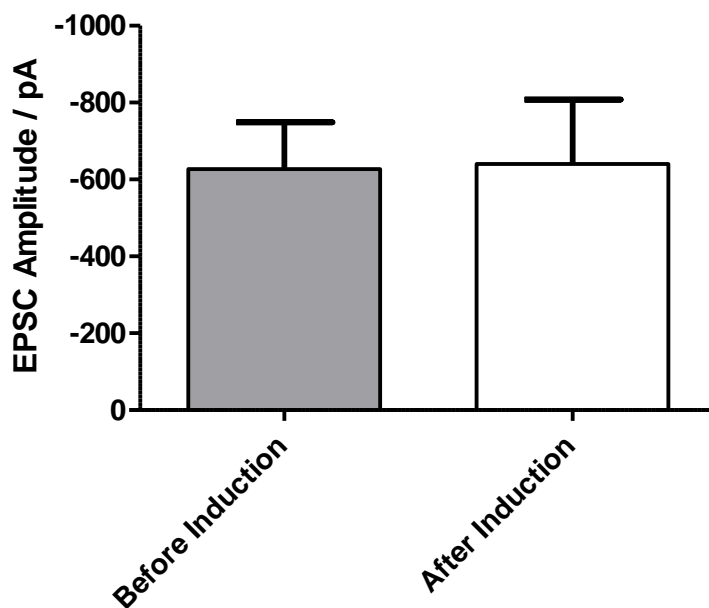

Figure A.16 MK-801 induction protocol does not result in LTD.

EPSC peak amplitudes did not differ between the start of the experiment (Before Induction) and 10 minutes following the induction protocol (After Induction). All recordings made in slices taken from naive C57BL/6J mice and stimulated to produce 50% of the maximum amplitude EPSC (n=5).

Presuming that the D-APV and MK-801 were active in all experiments, it was reasoned that perhaps there was a problem with the availability of the antagonists at the receptor. D-APV is a small molecule readily dissolved to 50mM in water (the concentration of the stock solution) so precipitation issues were ruled out. The fact that it is a small molecule means that problems with diffusion into the synaptic cleft were unlikely, and picrotoxin (a larger molecule) seemed to exert close to its maximum effects within 5 minutes (Figure A.17). Another reason for a drug not being available at the receptor could be due to its solubility in fat, highly lipid soluble compounds can readily dissolve into the fatty tissue in brain slices and so reduce the concentration of the drug dissolved in water. Obviously this reduces the concentration of the drug at the receptor. The predicted Log P value for D-APV however is -3.54 whereas picrotoxin is -1.08 (meaning APV is more hydrophilic than picrotoxin). This suggested that availability of APV at the receptor would not be affected by the presence of fatty tissue in the slice any more than for picrotoxin. In further support of this argument was the observation that morphine (more lipophilic than picrotoxin or D-APV, predicted Log P = 0.9) also reached equilibrium within 10 minutes (see results Figure A.15) (all Log P predictions from www.chemicalize.org). In conclusion, the reason why D-APV gave inconsistent results is unclear, however, as I was unable to routinely isolate pure AMPAR-mediated currents, alternative antagonist free methods of calculating AMPA:NMDA were investigated.

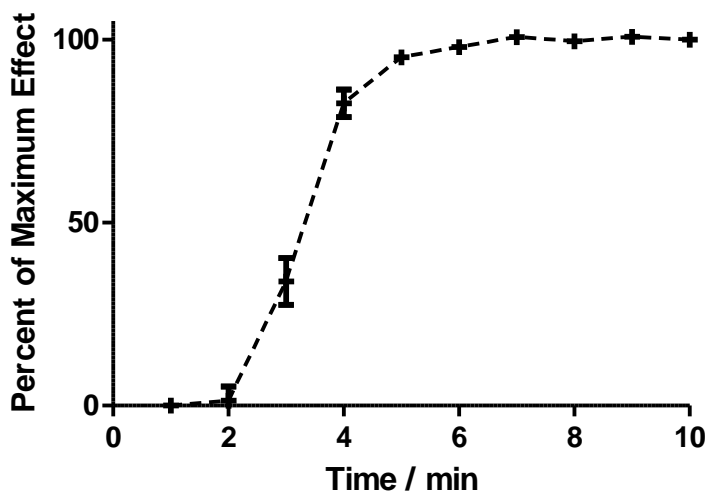

Figure A.17 Picrotoxin reaches maximum effect in approximately 3 minutes.

50 μ M picrotoxin was added to the bathing solution at time zero and picrotoxin-containing aCSF reached the slice chamber at approx $t = 2$ min. The neurone was held at 0mv and the resultant IPSC recorded. As can be seen from the graph, picrotoxin appeared to reach its maximum effect within approximately 3 minutes after reaching the slice chamber ($n=4$). All recordings made in slices taken from naive C57BL/6J mice and stimulated to produce 50% of the maximum amplitude EPSC.

A.2.3 Investigating the variability observed in the stimulus-response relationship within different treatment groups.

While it is entirely possible that the variability seen within treatment groups for the experiment presented in Figure 4.9 (effectively an input-output measure) is due to slight differences in the placement of the electrodes and connectivity of the patched neurone, other sources of experimental error were investigated. It was suggested that perhaps the current output of the stimulus isolation unit did not increase in a linear fashion as the control dial was turned. This could lead to errors in the plotting of the stimulus-response curve performed at the start of each experiment, and therefore not stimulating the cell to produce 75% of its maximum EPSC. To investigate this possibility, the stimulating electrode was first lowered into some ACSF. The potential difference between the positive and negative electrodes on the stimulating electrode was then monitored as the size of the stimulus was gradually increased throughout its range. As the resistance of this circuit should remain constant, the current delivered by the stimulating electrode

should be directly proportional to the voltage across it (as stated in Ohm's law). Figure A.18 shows the results of this experiment.

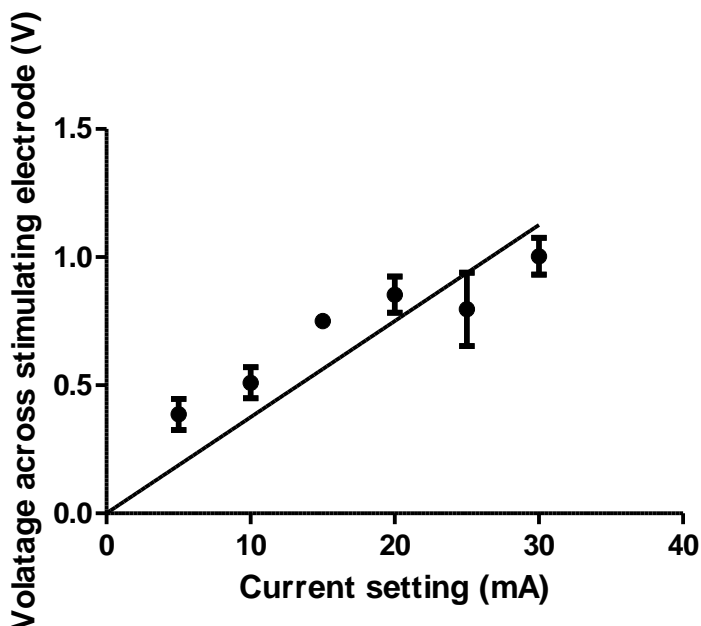

Figure A.18 A graph to show the current output of the stimulus isolation unit

A stimulating electrode was lowered into a solution of ACSF. The dial on the stimulus isolation unit (current setting) was then gradually increased and the voltage across the stimulating electrode measured. $n=3$ for each point. A runs test for linearity failed to find any deviation from linearity ($P=0.13$).

The runs test for linearity failed to find any deviation from a straight line (although clearly there is a small amount of variation in the current output). This result suggests that while the stimulus isolation unit may have been introducing some experimental error into the stimulus-response curves, this was unlikely to be significant, and some other source of variation may be needed to fully account for the variation seen in Figure 4.9.

References

- Abeliovich A, Chen C, Goda Y, Silva AJ, Stevens CF, Tonegawa S (1993) **Modified hippocampal long-term potentiation in PKC gamma-mutant mice.** *Cell* 75:1253–1262.
- Aberman JE, Salamone JD (1999) **Nucleus accumbens dopamine depletions make rats more sensitive to high ratio requirements but do not impair primary food reinforcement.** *Neuroscience* 92:545–578.
- Abraham WC (2003) **How long will long-term potentiation last?** *Philosophical Transactions of the Royal Society* 358:735-744.
- Abraham WC, Gustafsson B, Wigström H (1986) **Single high strength afferent volleys can produce long-term potentiation in the hippocampus in vitro.** *Neuroscience Letters* 70:217–222.
- Abraham WC, Mason-Parker SE, Bear MF, Webb S, Tate WP (2001) **Heterosynaptic metaplasticity in the hippocampus *in vivo*: a BCM-like modifiable threshold for LTP.** *Proceedings of the National Academy of Sciences USA* 98:10924-10929.
- Adesnik H, Nicoll RA (2007) **Conservation of glutamate receptor 2-containing AMPA receptors during long-term potentiation.** *The Journal of Neuroscience* 27:4598–4602.
- Akaike N, Hattori K, Oomura Y, Carpenter DO (1985) **Bicuculline and picrotoxin block gamma-aminobutyric acid-gated chloride conductance by different mechanisms.** *Experientia* 41:70–71
- Alford S, Frenguelli BG, Schofield JG, Collingridge GL (1993) **Characterization of Ca²⁺ signals induced in hippocampal CA1 neurones by the synaptic activation of NMDA receptors.** *Journal of Physiology* 469:693-716.
- Amaral D, Lavenex P (2007) **The hippocampus book.** Oxford University Press: Oxford.
- Andrasfalvy BK, Magee JC (2001) **Distance-dependent increase in AMPA receptor number in the dendrites of adult hippocampal CA1 pyramidal neurons.** *The Journal of Neuroscience* 21:9151-9159.
- Anggono V, Richard L Hugarir (2012) **Regulation of AMPA receptor trafficking and synaptic plasticity.** *Current Opinion in Neurobiology* 22:461–469.

- Argilli E, Sibley DR, Malenka RC, England PM, Bonci A (2008). **Mechanism and time course of cocaine-induced long-term potentiation in the ventral tegmental area.** The Journal of Neuroscience 28:9092–9100.
- Arias-Cavieres A, Rozas C, Reyes-Parada M, Barrera N, Pancetti F, Loyola S, Lorca RA, Zeise ML, Morales B (2010) **MDMA ("ecstasy") impairs learning in the Morris Water Maze and reduces hippocampal LTP in young rats.** Neuroscience Letters 469:375-379.
- Ashby MC, De La Rue SA, Ralph GS, Uney J, Collingridge GL, Henley JM (2004) **Removal of AMPA receptors (AMPA receptors) from synapses is preceded by transient endocytosis of extrasynaptic AMPARs.** The Journal of Neuroscience 24:5172-5176.
- Baker DA, McFarland K, Lake RW, Shen H, Tang XC, Toda S, Kalivas PW (2003) **Neuroadaptations in cystine-glutamate exchange underlie cocaine relapse.** Nature Neuroscience 6:743–749.
- Baler RD, Volkow ND (2006) **Drug addiction: the neurobiology of disrupted self-control.** Trends in Molecular Medicine 12:559–566.
- Bannister NJ, Larkman AU (1995) **Dendritic morphology of CA1 pyramidal neurones from the rat hippocampus: I. Branching patterns.** Journal of Comparative Neurology 360:150–160.
- Bao G, Kang L, Li H, Li Y, Pu L, Xia P, Ma L, Pei G (2007) **Morphine and heroin differentially modulate *in vivo* hippocampal LTP in opiate dependent rat.** Neuropsychopharmacology 32:1738 –1749.
- Barco A, Alancon JM, Kandel ER (2002) **Expression of constitutively active CREB protein facilitates the late phase of long term potentiation by enhancing synaptic capture.** Cell 108:689–703.
- Bardo MT, Bevins RA (2000) **Conditioned place preference: what does it add to our preclinical understanding of drug reward?** Psychopharmacology 153:31–43.
- Bardo MT, Rowlett KJ, Harris MJ (1995) **Conditioned place preference using opiate and stimulant drugs: a meta-analysis.** Neuroscience & Biobehavioral Reviews 19:39-51.
- Bartlett MS (1937) **Properties of sufficiency and statistical tests.** Proceedings of the Royal Statistical Society 160:268–282.
- Bashir ZI, Bortolotto ZA, Davies CH, Berretta N, Irving AJ, Seal AJ, Henley JM, Jane DE, Watkins JC, Collingridge GL (1993) **Induction of LTP in the**

- hippocampus needs synaptic activation of glutamate metabotropic receptors.** *Nature* 363:347-350.
- Bast T, da Silva BM, Morris RG (2005) **Distinct contributions of hippocampal NMDA and AMPA receptors to encoding and retrieval of one-trial place memory.** *The Journal of Neuroscience* 25:5845-5856.
- Bats C, Groc L, Choquet D (2007) **The interaction between Stargazin and PSD-95 regulates AMPA receptor surface trafficking.** *Neuron* 53:719–734.
- Bayazitov IT, Richardson RJ, Fricke RG, Zakharenko SS (2007) **Slow Presynaptic and Fast Postsynaptic Components of Compound Long-Term Potentiation.** *The Journal of Neuroscience* 27:11510-11521.
- Bayer HM, Glimcher PW (2005) **Midbrain dopamine neurons encode a quantitative reward prediction error signal.** *Neuron* 47:129–178.
- Bechtholt AJ, Gremel CM, Cunningham CL (2004) **Handling blocks expression of conditioned place aversion but not conditioned place preference produced by ethanol in mice.** *Pharmacology Biochemistry and Behavior* 79:739–744
- Beeler JA (2012) **Thorndike's Law 2.0: Dopamine and the Regulation of Thrift.** *Frontiers in Neuroscience* 6:116.
- Ben-Shahar O, Obara I, Ary AW, Ma N, Mangiardi MA, Medina RL, Szumlinski KK (2009) **Extended daily access to cocaine results in distinct alterations in Homer 1b/c and NMDA receptor subunit expression within the medial prefrontal cortex.** *Synapse* 63:598-609
- Betke KM, Wells CA, Hamm HE (2012) **GPCR mediated regulation of synaptic transmission.** *Progress in Neurobiology* 96:304-321.
- Billa SK, Liu J, Bjorklund NL, Sinha N, Fu Y, Shinnick-Gallagher P, Morón JA (2010a) **Increased insertion of glutamate receptor 2-lacking alpha-amino-3-hydroxy-5-methyl-4-isoxazole propionic acid (AMPA) receptors at hippocampal synapses upon repeated morphine administration.** *Molecular Pharmacology* 77:874-883.
- Billa SK, Xia Y, Morón JA (2010b) **Disruption of morphine-conditioned place preference by a delta2-opioid receptor antagonist: study of mu-opioid and delta-opioid receptor expression at the synapse.** *The European Journal of Neuroscience* 32:625-631.

- Bliss TVP, Lømo T (1973) **Long-lasting potentiation of synaptic transmission in the dentate area of the anaesthetized rabbit following stimulation of the perforant path.** *The Journal of Physiology* 232:331–356.
- Blitzer RD, Connor JH, Brown GP, Wong T, Shenolikar S, Iyengar R, Landau EM (1998) **Gating of CaMKII by cAMP-regulated protein phosphatase activity during LTP.** *Science* 280:1940-1942.
- Boehm J, Kang MG, Johnson RC, Esteban J, Huganir RL, Malinow R (2006) **Synaptic incorporation of AMPA receptors during LTP is controlled by a PKC phosphorylation site on GluR1.** *Neuron* 51:213–225.
- Borgland SL, Malenka RC, Bonci A (2004) **Acute and chronic cocaine-induced potentiation of synaptic strength in the ventral tegmental area: electrophysiological and behavioral correlates in individual rats.** *The Journal of Neuroscience* 24:7482–7490
- Bortolotto ZA, Bashir ZI, Davies CH, Collingridge GL (1994) **A molecular switch activated by metabotropic glutamate receptors regulates induction of long-term potentiation.** *Nature* 368:740-743.
- Bortolotto ZA, Collingridge GL (2000) **A role for protein kinase C in a form of metaplasticity that regulates the induction of longterm potentiation at CA1 synapses of the adult rat hippocampus.** *The European Journal of Neuroscience* 12:4055–4062.
- Bortolotto ZA, Nistico R, More JC, Jane DE, Collingridge GL. (2005) **Kainate receptors and mossy fiber LTP.** *Neurotoxicology* 26:769-777.
- Boudreau AC, Reimers JM, Milovanovic M, Wolf ME (2007) **Cell surface AMPA receptors in the rat nucleus accumbens increase during cocaine withdrawal but internalize after cocaine challenge in association with altered activation of mitogen-activated protein kinases.** *The Journal of Neuroscience* 27:10621–10635.
- Bradshaw KD, Emptage NJ, Bliss TVP (2003) **A role for dendritic protein synthesis is hippocampal late LTP.** *The European Journal of Neuroscience* 18:3150–3152.
- Broadbent NJ, Squire LR, Clark RE (2004). **Spatial memory, recognition memory, and the hippocampus.** *Proceedings of the National Academy of Sciences USA* 101:14515–14520.

- Buffalari DM, See RE (2010) **Amygdala mechanisms of Pavlovian psychostimulant conditioning and relapse**. *Current Topics in Behavioral Neurosciences* 3:73–99.
- Buzsaki G, Horvath Z, Urioste R, Hetke J, Wise K (1992) **High frequency network oscillation in the hippocampus**. *Science* 256:1025–1027.
- Caine SB, Humby T, Robbins TW, Everitt BJ (2001) **Behavioral effects of psychomotor stimulants in rats with dorsal or ventral subiculum lesions: locomotion, cocaine self-administration, and prepulse inhibition of startle**. *Behavioral Neuroscience* 115:880–894.
- Chen BT, Bowers MS, Martin M, Hopf FW, Guillory AM, Carelli RM, Chou JK, Bonci A (2008) **Cocaine but not natural reward self-administration nor passive cocaine infusion produces persistent LTP in the VTA**. *Neuron* 59:288–297.
- Chen L, Chetkovich DM, Petralia RS, Sweeney NT, Kawasaki Y, Wenthold RJ, Brecht DS, Nicoll RA (2000) **Stargazin regulates synaptic targeting of AMPA receptors by two distinct mechanisms**. *Nature* 408:936–943.
- Chevalyere V, Heifets BD, Kaeser PS, Südhof TC, Castillo PE (2007) **Endocannabinoid-mediated long term plasticity requires cAMP/PKA signaling and RIM1 α** . *Neuron* 54:801–812.
- Chevalyere V, Takahashi KA, Castillo PE (2006) **Endocannabinoid-mediated synaptic plasticity in the CNS**. *Annual Review of Neuroscience* 29:37–76.
- Childress AR, Mozley PD, McElgin W, Fitzgerald J, Reivich M, O'Brien CP (1999) **Limbic activation during cue-induced cocaine craving**. *The American Journal of Psychiatry* 156:11–8.
- Choi S, Klingauf J, Tsien RW (2000) **Postfusional regulation of cleft glutamate concentration during LTP at "silent synapses"**. *Nature Neuroscience* 3:330–336.
- Choi S, Klingauf J, Tsien RW (2003) **Fusion pore modulation as a presynaptic mechanism contributing to expression of long-term potentiation**. *Philosophical Transactions of the Royal Society B: Biological Sciences* 358:695–705.
- Colledge M, Dean RA, Scott GK, Langeberg LK, Huganir RL, Scott JD (2000) **Targeting of PKA to glutamate receptors through a MAGUK-AKAP complex**. *Neuron* 27:107–119.

- Contarino A, Picetti R, Matthes HW, Koob GF, Kieffer BL, Gold LH (2002) **Lack of reward and locomotor stimulation induced by heroin in mu-opioid receptor-deficient mice.** *The European Journal of Pharmacology* 446:103-109.
- Crombag HS, Shaham Y (2002) **Renewal of drug seeking by contextual cues after prolonged extinction in rats.** *Behavioral Neuroscience* 116:169–173.
- Cunningham CL (1993) **Pavlovian drug conditioning.** In: van Haaren F (ed) *Methods in behavioral pharmacology.* Elsevier, Amsterdam, pp 349–381
- Cunningham CL, Ferree NK, Howard MA (2003) **Apparatus bias and place conditioning with ethanol in mice.** *Psychopharmacology* 170:409-422.
- Cunningham CL, Niehus DR, Malott DH, Prather LK (1992) **Genetic differences in the rewarding and activating effects of morphine and ethanol.** *Psychopharmacology* 107:385–393.
- Cupello A, Plam A, Rapallino MV, Hyden H (1991) **Can Cl⁻ ions be extruded from gamma-aminobutyric (GABA)-acceptive nerve cell via GABA-A receptors on the plasma membrane cytoplasmic side?** *Cellular and Molecular Neurobiology* 11:333–346
- Davies CH, Starkey SJ, Pozza MF, Collingridge GL (1991) **GABA-B autoreceptors regulate the induction of LTP.** *Nature* 349: 609–611.
- Davies SN, Lester RA, Reymann KG, Collingridge GL (1989) **Temporally distinct pre- and post-synaptic mechanisms maintain long-term potentiation.** *Nature* 338:500–503.
- Debiec J, LeDoux JE, Nader K (2002) **Cellular and systems reconsolidation in the hippocampus.** *Neuron* 36:527-538.
- Del Olmo N, Higuera-Matas A, Miguéns M, García-Lecumberri C, Ambrosio E. (2007) **Cocaine self-administration improves performance in a highly demanding water maze task.** *Psychopharmacology* 195:19-25.
- Di Chiara G, Imperato A (1988) **Drugs abused by humans preferentially increase synaptic dopamine concentrations in the mesolimbic system of freely moving rats.** *Proceedings of the National Academy of Sciences USA* 85:5274–5278.
- Dingledine R, Hynes MA, King GL (1986) **Involvement of N-methyl-D-aspartate receptors in epileptiform bursting in the rat hippocampal slice.** *The Journal of Physiology* 380:175–189.
- Dong Y, Saal D, Thomas M, Faust R, Bonci A, Robinson T, Malenka RC (2004) **Cocaine-induced potentiation of synaptic strength in dopamine neurones: Behavioral**

- correlates in GluRA(-/-) mice.** Proceedings of the National Academy of Sciences 101:14282-14287.
- Douglas RM, Goddard GV (1975) **Long-term potentiation of the perforant path-granule cell synapse in the rat hippocampus.** Brain Research 86:205–215.
- Dudek SM, Friedlander MJ (1996) **Intracellular blockade of inhibitory synaptic responses in visual cortical layer IV neurons.** Journal of Neurophysiology 75:2167–2173
- Duffy JN, Nguyen PV (2003) **Postsynaptic application of a peptide inhibitor of cAMP-dependent protein kinase blocks expression of long-lasting synaptic potentiation in hippocampal neurons.** The Journal of Neuroscience 23:1142.
- Duffy SN, Nguyen PV (2003) **Postsynaptic application of a peptide inhibitor of cAMP-dependent protein kinase blocks expression of long-lasting synaptic potentiation in hippocampal neurons.** The Journal of Neuroscience 23:1142–1150.
- Dvorak-Carbone H, Schuman EM (1999) **Patterned activity in stratum lacunosum moleculare inhibits CA1 pyramidal neuron firing.** The Journal of Neurophysiology 82:3213-3222.
- Eberwine J, Miyashiro K, Kacharina JE, Job C (2001) **Local translation of classes of mRNAs that are targeted to neuronal dendrites.** Proceedings of the National Academy of Sciences USA 98:7080–7085.
- Einhorn LC, Johansen PA, White FJ (1988) **Electrophysiological effects of cocaine in the mesoaccumbens dopamine system: studies in the ventral tegmental area.** The Journal of Neuroscience 8:100–112.
- Engblom D, Bilbao A, Sanchis-Segura C, Dahan L, Perreau-Lenz S, Balland B, Parkitna JR, Luján R, Halbout B, Mameli M, Parlato R, Sprengel R, Lüscher C, Schütz G, Spanagel R (2008). **Glutamate receptors on dopamine neurons control the persistence of cocaine seeking.** Neuron 59:497–508.
- Enoki R, Hu YL, Hamilton D, Fine A (2009) **Expression of Long-Term Plasticity at Individual Synapses in Hippocampus Is Graded, Bidirectional, and Mainly Presynaptic: Optical Quantal Analysis.** Neuron 62:242-253
- Everitt BJ, Belin D, Economidou D, Pelloux Y, Dalley JW, Robbins TW (2008) **Neural mechanisms underlying the vulnerability to develop compulsive drug-seeking habits and addiction.** Philosophical Transactions of the Royal Society B: Biological Sciences 363(1507): 3125–3135.

- Everitt BJ, Robbins TW (2005) **Neural systems of reinforcement for drug addiction: from actions to habits to compulsion.** *Nature Neuroscience* 8:1481–1489.
- Fanselow MS, Dong HW (2010) **Are the dorsal and ventral hippocampus functionally distinct structures?** *Neuron* 65:7-19.
- Farahmandfar M, Zarrindast MR, Kadivar M, Karimian SM, Naghdi N (2011) **The effect of morphine sensitization on extracellular concentrations of GABA in dorsal hippocampus of male rats.** *The European Journal of Pharmacology* 669(1-3):66-70.
- Ferbinteanu J, McDonald RJ (2001) **Dorsal/ventral hippocampus, fornix, and conditioned place preference.** *Hippocampus* 11:187-200.
- Fiorillo CD, Tobler PN, Schultz W. (2003). **Discrete coding of reward probability and uncertainty by dopamine neurons.** *Science* 299:1898–1878.
- Frey U, Krug M, Brodemann R, Reymann K, Matthies H (1989) **Long-term potentiation induced in dendrites separated from rats CA1 pyramidal somata does not establish a late phase.** *Neuroscience Letters* 97:135-139.
- Frey U, Krug M, Reymann KG, Matthies H (1988) **Anisomycin, an inhibitor of protein synthesis, blocks late phases of LTP phenomena in the hippocampal CA1 region in vitro.** *Brain Research* 452:57–65.
- Frey U, Morris RGM (1997) **Synaptic tagging and long-term potentiation.** *Nature* 385:533–536.
- Frey U, Schroeder H, Matthies H (1990) **Dopaminergic antagonists prevent long-term maintenance of posttetanic LTP in the CA1 region of rat hippocampal slices.** *Brain Research* 522:69–75.
- Fu Y, Pollandt S, Liu J, Krishnan B, Genzer K, Orozco-Cabal L, Gallagher JP, Shinnick-Gallagher P (2007) **Long-term potentiation (LTP) in the central amygdala (CeA) is enhanced after prolonged withdrawal from chronic cocaine and requires CRF1 receptors.** *The Journal of Neurophysiology* 97:937–941.
- Fuchs RA, See RE (2002). **Basolateral amygdala inactivation abolishes conditioned stimulus- and heroin-induced reinstatement of extinguished heroin-seeking behavior in rats.** *Psychopharmacology* 160:425–433.
- Fucile S, Miledi R, Eusebi F (2006) **Effects of cyclothiazide on GluR1/AMPA receptors.** *Proceedings of the National Academy of Sciences USA* 103:2943-2947

- Fujii S, Saito K, Miyakawa H, Ito K, Kato H (1991) **Reversal of long-term potentiation (depotential) induced by tetanus stimulation of the input to CA1 neurons of guinea pig hippocampal slices.** *Brain Research* 555:112-122.
- Gabriele A, See RE (2010). **Reversible inactivation of the basolateral amygdala, but not the dorsolateral caudate putamen, attenuates consolidation of cocaine-cue associative learning in a reinstatement model of drug-seeking.** *European Journal of Neuroscience* 32:1024–1029.
- Gallistel CR, Stellar JR, Bubis E (1974) **Parametric analysis of brain stimulation reward in the rat: I. The transient process and the memory-containing process.** *Journal of Comparative and Physiological Psychology* 87:848–859.
- Gardner EL (2000), **What We Have Learned about Addiction from Animal Models of Drug Self-Administration.** *The American Journal on Addictions*, 9: 285–313.
- Gasbarri A, Sulli A, Packard MG (1997) **The dopaminergic mesencephalic projections to the hippocampal formation in the rat.** *Progress in Neuro-Psychopharmacology & Biological Psychiatry* 21:1–22.
- Gasbarri A, Verney C, Innocenzi R, Campana E, Pacitti C (1994) **Mesolimbic dopaminergic neurons innervating the hippocampal formation in the rat: a combined retrograde tracing and immunohistochemical study.** *Brain Research* 668:71–79.
- Gaykema RP, van der Kuil J, Hersh LB, Luiten PG (1991) **Patterns of direct projections from the hippocampus to the medial septum-diagonal band complex: Anterograde tracing with Phaseolus vulgaris leucoagglutinin combined with immunohistochemistry of choline acetyltransferase.** *Neuroscience* 43(2–3):349–360.
- Gerdjikov TV, Ross GM, Beninger RJ (2004) **Place preference induced by nucleus accumbens amphetamine is impaired by antagonists of ERK or p38 MAP kinases in rats.** *Behavioral Neuroscience* 118:740–750.
- Gibb AJ, Edwards FA (1994) **Patch clamp recording from cells in sliced tissues.** In: *Microelectrode techniques. The Plymouth Workshop handbook*, (Ogden D, ed), pp 255-274 The Company of Biologists Limited, Cambridge.
- Giese KP, Fedorov NB, Filipkowski RK & Silva, AJ (1998) **Autophosphorylation at Thr286 of the alpha calcium-calmodulin kinase II in LTP and learning.** *Science* 279:870–873.

- Gonzalez-Burgos G, Rotaru DC, Zaitsev AV, Povysheva NV, Lewis DA (2009) **GABA transporter GAT1 prevents spillover at proximal and distal GABA synapses onto primate prefrontal cortex neurons.** *The Journal of Neurophysiology* 101:533-547.
- Goto Y, Grace AA (2005) **Dopamine-dependent interactions between limbic and prefrontal cortical plasticity in the nucleus accumbens: disruption by cocaine sensitization.** *Neuron* 47:255–266.
- Goto Y, Grace AA (2005) **Dopaminergic modulation of limbic and cortical drive of nucleus accumbens in goal-directed behavior.** *Nature Neuroscience* 8:805-812.
- Goussakov I, Chartoff EH, Tsvetkov E, Gerety LP, Meloni EG, Carlezon WA Jr, Bolshakov VY (2006) **LTP in the lateral amygdala during cocaine withdrawal.** *European Journal of Neuroscience* 23:239–250.
- Grace AA, Floresco SB, Goto Y, Lodge DJ (2007) **Review Regulation of firing of dopaminergic neurons and control of goal-directed behaviors.** *Trends in Neurosciences* 30:220-227.
- Graves AR, Moore SJ, Bloss EB, Mensh BD, Kath WL, Spruston N (2012) **Hippocampal pyramidal neurons comprise two distinct cell types that are countermodulated by metabotropic receptors.** *Neuron* 76:776-789
- Granado N, Ortiz O, Suárez LM, Martín ED, Ceña V, Solís JM, Moratalla R (2008) **D1 but not D5 Dopamine Receptors Are Critical for LTP, Spatial Learning, and LTP-Induced arc and zif268 Expression in the Hippocampus.** *Cerebral Cortex* 18:1-12.
- Gray EE, Fink AE, Sariñana J, Vissel B, O'Dell TJ (2007) **Long-Term Potentiation in the Hippocampal CA1 Region Does Not Require Insertion and Activation of GluR2-Lacking AMPA Receptors.** *The Journal of Neurophysiology* 98: 2488-2492.
- Gu Z, Yakel JL (2011) **Timing-dependent septal cholinergic induction of dynamic hippocampal synaptic plasticity.** *Neuron* 71:155-165.
- Guan X, Zhang R, Xu Y, Li S (2009) **Cocaine withdrawal enhances long-term potentiation in rat hippocampus via changing the activity of corticotropin-releasing factor receptor subtype 2.** *Neuroscience* 161:665–670.
- Guire ES, Oh MC, Soderling TR, Derkach VA (2008) **Recruitment of calcium-permeable AMPA receptors during synaptic potentiation is regulated by CaM-kinase.** *The Journal of Neuroscience* 28:6000–6009.

- Han KS, Woo J, Park H, Yoon BJ, Choi S, Lee CJ (2013) **Channel-mediated astrocytic glutamate release via Bestrophin-1 targets synaptic NMDARs.** *Molecular Brain* 6:4.
- Harris GC, Aston-Jones G (2003) **Critical role for ventral tegmental glutamate in preference for a cocaine conditioned environment.** *Neuropsychopharmacology* 28:73–76.
- Harris GC, Wimmer M, Byrne R, Aston-Jones G (2004) **Glutamate-associated plasticity in the ventral tegmental area is necessary for conditioning environmental stimuli with morphine.** *Neuroscience* 129:841-7.
- Harvey J, Collingridge GL (1992) **Thapsigargin blocks the induction of long-term potentiation in rat hippocampal slices.** *Neuroscience Letters* 139:197–200.
- Hebb DO (1949) **The organization of behavior.** New York: Wiley.
- Hernandez AI, Blace N, Crary JF, Serrano PA, Leitges M, Libien JM, Weinstein G, Tcherapanov A, Sacktor TC (2003) **Protein kinase M zeta synthesis from a brain mRNA encoding an independent protein kinase C zeta catalytic domain. Implications for the molecular mechanism of memory.** *The Journal of Biological Chemistry* 278:40305–40316.
- Hernández-Rabaza V, Hontecillas-Prieto L, Velázquez-Sánchez C, Ferragud A, Pérez-Villaba A, Arcusa A, Barcia JA, Trejo JL, Canales JJ (2008) **The hippocampal dentate gyrus is essential for generating contextual memories of fear and drug-induced reward.** *Neurobiology of Learning and Memory* 90:553-559.
- Hollup SA, Molden S, Donnett JG, Moser MB, Moser EI (2001) **Accumulation of hippocampal place fields at the goal location in an annular watermaze task.** *The Journal of Neuroscience* 21:1635-1644.
- Hu H, Real E, Takamiya K, Kang MG, Ledoux J, Huganir RL, Malinow R (2007) **Emotion Enhances Learning via Norepinephrine Regulation of AMPA-Receptor Trafficking.** *Cell* 131:160–173.
- Huang YH, Lin Y, Mu P, Lee BR, Brown TE, Wayman G, Marie H, Liu W, Yan Z, Sorg BA, Schlüter OM, Zukin RS, Dong Y (2009) ***In vivo* cocaine experience generates silent synapses.** *Neuron* 63:40–47.
- Huang YY, Kandel ER (1994) **Recruitment of long-lasting and protein kinase A-dependent long-term potentiation in the CA1 region of hippocampus requires repeated tetanization.** *Learning and Memory* 1:74–82.

- Huang YY, Kandel ER (1995) **D1/D5 receptor agonists induce a protein synthesis-dependent late potentiation in the CA1 region of the hippocampus.** Proceedings of the National Academy of Sciences USA 92:2446–2450.
- Hunt DL, Castillo PE (2012) **Synaptic plasticity of NMDA receptors: mechanisms and functional implications.** Current Opinion in Neurobiology. 22:496–508
- Hyman JM, Wyble BP, Goyal V, Rossi CA, Hasselmo ME (2003) **Stimulation in Hippocampal Region CA1 in Behaving Rats Yields Long-Term Potentiation when Delivered to the Peak of Theta and Long-Term Depression when Delivered to the Trough.** The Journal of Neuroscience 23:11725-11731.
- Inomata N, Tokutomi N, Oyama Y, Akaike N (1988) **Intracellular picrotoxin blocks pentobarbital-gated chloride conductance.** Neuroscience Research 6:72–75.
- Isa T, Iino M, Itazawa S, Ozawa S (1995) **Spermine mediates inward rectification of Ca(2+)-permeable AMPA receptor channels.** Neuroreport 6:2045-2048.
- Ito R, Robbins TW, McNaughton BL, Everitt BJ (2006) **Selective excitotoxic lesions of the hippocampus and basolateral amygdala have dissociable effects on appetitive cue and place conditioning based on path integration in a novel Y-maze procedure.** Eur The Journal of Neuroscience 23:3071-3080.
- Ito R, Robbins TW, Pennartz CM, Everitt BJ (2008) **Functional interaction between the hippocampus and nucleus accumbens shell is necessary for the acquisition of appetitive spatial context conditioning.** The Journal of Neuroscience 28:6950-6959.
- Izumi Y, Zorumski CF (1999) **Norepinephrine promotes long-term potentiation in the adult rat hippocampus in vitro.** Synapse 31:196-202.
- Jang IS, Ito Y, Akaike, N (2005) **Feed-forward facilitation of glutamate release by presynaptic GABAA receptors.** Neuroscience 135:737–748.
- Jarosiewicz B, Skaggs WE (2004) **Hippocampal place cells are not controlled by visual input during the small irregular activity state in the rat.** The Journal of Neuroscience 24:5070–5077.
- Jenkins TA, Amin E, Pearce JM, Brown MW, Aggleton JP (2004) **Novel spatial arrangements of familiar visual stimuli promote activity in the rat**

- hippocampal formation but not the parahippocampal cortices: a c-fos expression study.** *Neuroscience* 124:43–52.
- Jeziorski M, White FJ, Wolf ME (1994) **MK-801 prevents the development of behavioral sensitization during repeated morphine administration.** *Synapse* 16:137–147.
- Johnson SW, North RA (1992) **Opioids excite dopamine neurons by hyperpolarization of local interneurons.** *The Journal of Neuroscience* 12:483–488.
- Kalivas PW, Alesdatter JE (1993) **Involvement of NMDA receptor stimulation in the ventral tegmental area and amygdala in behavioral sensitization to cocaine.** *Journal of Pharmacology and Experimental Therapeutics* 267:486–495.
- Karler R, Calder LD, Chaudhry IA, Turkanis SA (1989) **Blockade of “reverse tolerance” to cocaine and amphetamine by MK-801.** *Life Sciences* 45:599–606.
- Kasanetz F, Deroche-Gamonet V, Berson N, Balado E, Lafourcade M, Manzoni O, Piazza PV (2010) **Transition to addiction is associated with a persistent impairment in synaptic plasticity.** *Science* 328:1709–1712.
- Katsuki H, Izumi Y, Zorumski C (1997) **Noradrenergic regulation of synaptic plasticity in the hippocampal CA1 region.** *The Journal of Neurophysiology* 77:3013-20.
- Kay AR (1992) **An intracellular medium formulary.** *Journal of Neuroscience Methods* 44:91–100.
- Kazanietz MG, Caloca MJ, Eroles P, Fujii T, Garcia-Bermejo ML, Reilly M, Wang H (2000) **Pharmacology of the receptors for the phorbol ester tumor promoters: multiple receptors with different biochemical properties.** *Biochemical Pharmacology* 60:1417–1424.
- Kelley AE, Berridge KC (2002) **The Neuroscience of Natural Rewards: Relevance to Addictive Drugs.** *The Journal of Neuroscience* 22:3306-3311.
- Kelley AE, Domesick VB (1982) **The distribution of the projection from the hippocampal formation to the nucleus accumbens in the rat: An anterograde and retrograde-horseradish peroxidase study.** *Neuroscience* 7:2321–2335.

- Kessels RP, de Haan EH, Kappelle LJ, Postma A (2001) **Varieties of human spatial memory: a meta-analysis on the effects of hippocampal lesions.** *Brain Research Reviews* 35:295–303.
- Kilts CD, Schweitzer JB, Quinn CK, Gross RE, Faber TL, Muhammad F, Ely TD, Hoffman JM, Drexler KP (2001) **Neural Activity Related to Drug Craving in Cocaine Addiction.** *Archives of General Psychiatry* 58:334-341.
- Kim HS, Park WK, Jang CG, Oh S (1996) **Inhibition by MK-801 of cocaine-induced sensitization, conditioned place preference, and dopamine-receptor supersensitivity in mice.** *Brain Research Bulletin* 40:201–207.
- Kim JJ, Foy MR, Thompson RF (1996) **Behavioral stress modifies hippocampal plasticity through N-methyl-D-aspartate receptor activation.** *Proceedings of the National Academy of Sciences* 93:4750–4753.
- Kleschevnikov AM, Sokolov MV, Kuhnt U, Dawe GS, Stephenson JD, Voronin LL (1997) **Changes in paired-pulse facilitation correlate with induction of long-term potentiation in area CA1 of rat hippocampal slices.** *Neuroscience* 76:829–843.
- Kojima N, Wang J, Mansuy IM, Grant SG, Mayford M, Kandel ER (1997) **Rescuing impairment of long-term potentiation in fyn deficient mice by introducing Fyn transgene.** *Proceedings of the National Academy of Sciences USA* 94:4761–4765.
- Kojima T, Matsumoto M, Togashi H, Tachibana K, Kemmotsu O, Yoshioka M (2003) **Fluvoxamine suppresses the long-term potentiation in the hippocampal CA1 field of anesthetized rats: an effect mediated via 5-HT_{1A} receptors.** *Brain Research* 959:165–168.
- Kolb B, Gorny G, Li Y, Samaha AN, Robinson TE (2003) **Amphetamine or cocaine limits the ability of later experience to promote structural plasticity in the neocortex and nucleus accumbens.** *Proceedings of the National Academy of Sciences USA* 100:10523–10528.
- Kolta A, Lynch G, Ambros-Ingerson J (1998) **Effects of aniracetam after LTP induction are suggestive of interactions on the kinetics of the AMPA receptor channel.** *Brain Research* 788:269–286.
- Konorski J (1948) **Conditioned reflexes and neuron organization.** Cambridge, UK: Hefner.

- Kourrich S, Rothwell PE, Klug JR, Thomas MJ (2007) **Cocaine experience controls bidirectional synaptic plasticity in the nucleus accumbens** *The Journal of Neuroscience* 27:7921–7928.
- Koya E, Cruz FC, Ator R, Golden SA, Hoffman AF, Lupica CR, Hope BT (2012) **Silent synapses in selectively activated nucleus accumbens neurons following cocaine sensitization.** *Nature Neuroscience* 15:1556-1562.
- Kramis R, Vanderwolf CH, Bland BH (1975) **Two types of hippocampal rhythmical slow activity in both the rabbit and the rat: relations to behavior and effects of atropine, diethyl ether, urethane, and pentobarbital.** *Experimental Neurology* 49:58–85.
- Kreitzer AC, Malenka RC (2008) **Striatal plasticity and basal ganglia circuit function.** *Neuron* 60:543–554.
- Kristensen AS, Jenkins MA, Banke TG, Schousboe A, Makino Y, Johnson RC, Huganir R, Traynelis SF (2011) **Mechanism of Ca(2)/calmodulin-dependent kinase II regulation of AMPA receptor gating.** *Nature Neuroscience* 14:727–735.
- Krug M, Lössner B, Ott T (1984) **Anisomycin blocks the late phase of long-term potentiation in the dentate gyrus of freely moving rats.** *Brain Research Bulletin* 13:39-42.
- Kruzich PJ, Congleton KM, See RE (2001) **Conditioned reinstatement of drug-seeking behavior with a discrete compound stimulus classically conditioned with intravenous cocaine.** *Behavioral Neuroscience* 115:1086–1092.
- Kruzich PJ, See RE (2001) **Differential contributions of the basolateral and central amygdala in the acquisition and expression of conditioned relapse to cocaine-seeking behavior.** *The Journal of Neuroscience* 21:RC155.
- Kumar A (2011) **Long-term potentiation at CA3–CA1 hippocampal synapses with special emphasis on aging, disease, and stress.** *Frontiers in Aging Neuroscience* 3:7.
- Kwag J, Paulsen O (2012) **Gating of NMDA receptor-mediated hippocampal spike timing-dependent potentiation by mGluR5,** *Neuropharmacology* 63:701-709.
- Lee HK (2006) **Synaptic plasticity and phosphorylation.** *Pharmacology & Therapeutics* 112:810–832.

- Lee HK, Takamiya K, Han JS, Man H, Kim CH, Rumbaugh G, Yu S, Ding L, He C, Petralia RS, Wenthold RJ, Gallagher M, Huganir RL (2003) **Phosphorylation of the AMPA Receptor GluR1 Subunit Is Required for Synaptic Plasticity and Retention of Spatial Memory.** Cell 112:631–643.
- Lee HK, Takamiya K, He K, Song L, Huganir RL (2010) **Specific roles of AMPA receptor subunit GluR1 (GluA1) phosphorylation sites in regulating synaptic plasticity in the CA1 region of hippocampus.** The Journal of Neurophysiology 103:479–489.
- Lee I, Hunsaker MR, Kesner RP (2005) **The role of hippocampal subregions in detecting spatial novelty.** Behavioral Neuroscience 119:145–153.
- Leung LS, Shen B, Rajakumar N, Ma J (2003) **Cholinergic activity enhances hippocampal long-term potentiation in CA1 during walking in rats.** The Journal of Neuroscience 23:9297-9304.
- Li HB, Jackson MF, Yang K, Trepanier C, Salter MW, Orser BA, MacDonald JF (2011) **Plasticity of synaptic glutamate receptors is required for the Src-dependent induction of long-term potentiation at CA3-CA1 synapses.** Hippocampus 21:1053–1061.
- Li S, Cullen WK, Anwyl R, Rowan MJ (2003) **Dopamine-dependent facilitation of LTP induction in hippocampal CA1 by exposure to spatial novelty.** Nature Neuroscience 6:526 – 531.
- Li X-G, Somogyi P, Ylinen A, Buzsaki G (1994) **The hippocampal CA3 network: an *in vivo* intracellular labeling study.** Journal of Comparative Neurology 339:181–208.
- Lin B, Brucher FA, Colgin LL, Lynch G (2002) **Long-Term Potentiation Alters the Modulator Pharmacology of AMPA-Type Glutamate Receptors.** The Journal of Physiology 87:2790-2800.
- Ling DS, Benardo LS, Serrano PA, Blace N, Kelly MT, Crary JF, Sacktor TC (2002) **Protein kinase M zeta is necessary and sufficient for LTP maintenance.** Nature Neuroscience 5:295–296.
- Lisman J, Raghavachari S (2006) **A unified model of the presynaptic and postsynaptic changes during LTP at CA1 synapses.** Sci STKE (356):re11.
- Lisman J, Yasuda R, Raghavachari S (2012) **Mechanisms of CaMKII action in long-term potentiation.** Nature Reviews Neuroscience 13:169-182.
- Lisman JE, Grace AA (2005) **The hippocampal-VTA loop: controlling the entry of information into long-term memory.** Neuron 46:703–713.

- Liu QS, Pu L, Poo MM (2005) **Repeated cocaine exposure *in vivo* facilitates LTP induction in midbrain dopamine neurons.** *Nature* 437:1027–1031.
- Liu SJ, Zukin RS (2007) **Ca²⁺-permeable AMPA receptors in synaptic plasticity and neuronal death.** *Trends in Neurosciences* 30:126–134.
- Lledo PM, Mukherji S, Soderling TR, Malenka RC, Nicoll RA (1995) **Calcium/calmodulin-dependent kinase II and long-term potentiation enhance synaptic transmission by the same mechanism.** *Proceedings of the National Academy of Sciences USA* 92:11175–11179.
- Lodge DJ, Grace AA (2006) **The hippocampus modulates dopamine neuron responsivity by regulating the intensity of phasic neuron activation.** *Neuropsychopharmacology* 31:1356-1361.
- Lonze B, Ginty DD (2002) **Function and regulation of CREB family transcription factors in the nervous system.** *Neuron* 35:605–623.
- Lovinger DM, Wong KL, Murakami K, Routtenberg A (1987) **Protein kinase C inhibitors eliminate hippocampal long-term potentiation.** *Brain Research* 436:177–183.
- Lu G, Zhou QX, Kang S, Li QL, Zhao LC, Chen JD, Sun JF, Cao J, Wang YJ, Chen J, Chen XY, Zhong DF, Chi ZQ, Xu L, Liu JG (2010) **Chronic morphine treatment impaired hippocampal long-term potentiation and spatial memory via accumulation of extracellular adenosine acting on adenosine A₁ receptors.** *The Journal of Neuroscience* 30:5058-5070.
- Lu L, Dempsey J, Shaham Y, Hope B T (2005a). **Differential long-term neuroadaptations of glutamate receptors in the basolateral and central amygdala after withdrawal from cocaine self-administration in rats.** *Journal of Neurochemistry* 94:161–168.
- Lu L, Hope BT, Dempsey J, Liu SY, Bossert JM, Shaham Y (2005b) **Central amygdala ERK signaling pathway is critical to incubation of cocaine craving.** *Nature Neuroscience* 8:212–219.
- Luo AH, Tahsili-Fahadan P, Wise RA, Lupica CR, Aston-Jones G (2011) **Linking context with reward: a functional circuit from hippocampal CA3 to ventral tegmental area.** *Science* 333:353-357.
- Lüscher C, Huber KM (2010) **Group 1 mGluR-dependent synaptic long-term depression: mechanisms and implications for circuitry and disease.** *Neuron* 65:445-459.

- Lüscher C, Malenka RC (2012) **NMDA receptor-dependent long-term potentiation and long-term depression (LTP/LTD)**. Cold Spring Harb Perspect Biol. 4(6).
- Lüscher C, Xia H, Beattie EC, Carroll RC, von Zastrow M, Malenka RC, Nicoll RA (1999) **Role of AMPA Receptor Cycling in Synaptic Transmission and Plasticity**. Neuron 24:649-658.
- Luu P, Malenka RC (2008) **Spike timing-dependent long-term potentiation in ventral tegmental area dopamine cells requires PKC**. The Journal of Neurophysiology 100:533–538.
- Lynch G, Larson J, Kelso S, Barrionuevo G, Schottler F (1983) **Intracellular injections of EGTA block induction of hippocampal long-term potentiation**. Nature 305:719–721.
- Ma YY, Yu P, Guo CY, Cui CL (2011) **Effects of Ifenprodil on Morphine-Induced Conditioned Place Preference and Spatial Learning and Memory in Rats**. Neurochemical Research 36:383-391.
- Ma YY, Guo CY, Yu P, Lee DY, Han JS, Cui CL(2006) **The role of NR2B containing NMDA receptor in place preference conditioned with morphine and natural reinforcers in rats**. Experimental Neurology 200:343–355.
- Madroñal N, Gruart A, Sacktor TC, Delgado-García JM (2010) **PKMzeta inhibition reverses learning-induced increases in hippocampal synaptic strength and memory during trace eyeblink conditioning**. PLoS One 5:e10400.
- Malenka RC, Bear MF (2004) **LTP and LTD: an embarrassment of riches**. Neuron 44:5-21.
- Malenka RC, Nicoll RA (1999) **Long-term potentiation — a decade of progress?** Science 285:1870–1874.
- Mameli M, Bellone C, Brown MT, Lüscher C (2011) **Cocaine inverts rules for synaptic plasticity of glutamate transmission in the ventral tegmental area**. Nature Neuroscience 14:414–416.
- Mansouri FA, Motamedi F, Fathollahi Y (1999) **Chronic *in vivo* morphine administration facilitates primed-bursts-induced long-term potentiation of Schaffer collateral-CA1 synapses in hippocampal slices in vitro**. Brain Research 815:419-423.
- Manzoni OJ, Weisskopf MG, Nicoll RA (1994) **MCPG antagonizes metabotropic glutamate receptors but not long-term potentiation in the hippocampus**. The European Journal of Neuroscience 6:1050-1054.

- Marie-Claire C, Courtin C, Robert A, Gidrol X, Roques BP, Noble F (2007) **Sensitization to the conditioned rewarding effects of morphine modulates gene expression in rat hippocampus.** *Neuropharmacology* 52:430–435.
- Marissen MA, Franken IH, Blanken P, van den Brink W, Hendriks VM (2007) **Cue exposure therapy for the treatment of opiate addiction: results of a randomized controlled clinical trial.** *Psychotherapy and Psychosomatics* 76:97-105.
- Martin M, Chen BT, Hopf FW, Bowers MS, Bonci A (2006) **Cocaine self administration selectively abolishes LTD in the core of the nucleus accumbens.** *Nature Neuroscience* 9:868–869.
- Martin SJ, Grimwood PD, Morris RG (2000) **Synaptic plasticity and memory: an evaluation of the hypothesis.** *Annual Reviews in Neuroscience* 23:649-711.
- Martin SJ, Morris RG (1997) **(R,S)-alpha-methyl-4-carboxyphenylglycine (MCPG) fails to block long-term potentiation under urethane anaesthesia *in vivo*.** *Neuropharmacology* 36:1339-1354.
- Matsuzaki M, Honkura N, Ellis-Davies GCR, Kasai H (2004) **Structural basis of long-term potentiation in single dendritic spines.** *Nature* 429:761–766.
- Matthies H, Becker A, Schroeder H, Kraus J, Holtt V, Krug M (1997) **Dopamine D1-deficient mutant mice do not express the late phase of hippocampal long-term potentiation.** *Neuroreport* 8:3533–3535.
- Matthies H, Reymann KG (1993) **Protein kinase A inhibitors prevent the maintenance of hippocampal long-term potentiation.** *Neuroreport* 4:712–714.
- Maurer AP, Vanrhoads SR, Sutherland GR, Lipa P, McNaughton BL (2005) **Self-motion and the origin of differential spatial scaling along the septo-temporal axis of the hippocampus.** *Hippocampus* 15:841–852.
- Mayer ML, Westbrook GL, Guthrie PB (1984) **Voltage-dependent block by Mg²⁺ of NMDA responses in spinal cord neurones.** *Nature* 309:261–263.
- McBain C, Dingledine R (1992) **Dual-component miniature excitatory synaptic currents in rat hippocampal CA3 pyramidal neurons.** *The Journal of Neurophysiology* 68:16-27
- McLaughlin J, See RE (2003) **Selective inactivation of the dorsomedial prefrontal cortex and the basolateral amygdala attenuates conditioned-reinstatement of extinguished cocaine-seeking behavior in rats.** *Psychopharmacology* 168:57–65.

- McQuiston AR (2008) **Layer selective presynaptic modulation of excitatory inputs to hippocampal cornu Ammon 1 by μ -opioid receptor activation.** *Neuroscience* 151:209-221.
- McQuiston AR (2011) **Mu opioid receptor activation normalizes temporo-ammonic pathway driven inhibition in hippocampal CA1.** *Neuropharmacology* 60:472–479.
- Meil WM, See RE (1997) **Lesions of the basolateral amygdala abolish the ability of drug associated cues to reinstate responding during withdrawal from self-administered cocaine.** *Behavioural Brain Research* 87:139–148.
- Meyers RA, Zavala AR, Speer CM, Neisewander JL (2006) **Dorsal hippocampus inhibition disrupts acquisition and expression, but not consolidation, of cocaine conditioned place preference.** *Behavioral Neuroscience* 120:401–412.
- Miguens M, Del Olmo N, Higuera-Matas A, Torres I, Garcia-Lecumberri C, Ambrosio E (2008) **Glutamate and aspartate levels in the nucleus accumbens during cocaine self-administration and extinction: A time course microdialysis study.** *Psychopharmacology* 196:303–313.
- Milekic MH, Brown SD, Castellini C, Alberini CM (2006) **Persistent Disruption of an Established Morphine Conditioned Place Preference.** *The Journal of Neuroscience* 26:3010-3020.
- Miller CA, Marshall JF (2005) **Molecular substrates for retrieval and reconsolidation of cocaine-associated contextual memory.** *Neuron* 47:873–884.
- Milner B (1962) **Les troubles de la memoire accompagnant des lesions hippocampiques bilaterales.** In: *Physiologie de l'hippocampe* (P Passouant, ed.), pp. 257–272. Paris: Centre National de la Recherche Scientifique.
- Mirenowicz J, Schultz W (1994) **Importance of unpredictability for reward responses in primate dopamine neurons.** *The Journal of Neurophysiology* 72:1024–1078.
- Moita M, Rosis S, Zhou Y, LeDoux JE, Blair HT (2004) **Putting Fear in Its Place: Remapping of Hippocampal Place Cells during Fear Conditioning.** *The Journal of Neuroscience* 24:7015-7023.
- Moran MM, McFarland K, Melendez RI, Kalivas PW, Seamans JK (2005) **Cystine/glutamate exchange regulates metabotropic glutamate receptor**

- presynaptic inhibition of excitatory transmission and vulnerability to cocaine seeking.** *The Journal of Neuroscience* 25:6389–6393.
- Morris RG, Inglis J, Ainge JA, Olverman HJ, Tulloch J, Dudai Y, Kelly PA (2006) **Memory Reconsolidation: Sensitivity of Spatial Memory to Inhibition of Protein Synthesis in Dorsal Hippocampus during Encoding and Retrieval.** *Neuron* 50:479-489.
- Moult PR, Cross A, Santos SD, Carvalho AL, Lindsay Y, Connolly CN, Irving J, Leslie NR, Harvey J (2010) **Leptin regulates AMPA receptor trafficking via PTEN inhibition.** *The Journal of Neuroscience* 30:4088–4101.
- Moussawi K, Pacchioni A, Moran M, Olive MF, Gass JT, Lavin A, Kalivas PW (2009). **N-Acetylcysteine reverses cocaine-induced metaplasticity.** *Nature Neuroscience* 12:182–189.
- Moussawi K, Zhou W, Shen H, Reichel CM, See RE, Carr DB, Kalivas PW (2011) **Reversing cocaine-induced synaptic potentiation provides enduring protection from relapse.** *Proceedings of the National Academy of Sciences USA* 108:385–390.
- Mueller D and Stewart J (2000) **Cocaine-induced conditioned place preference: reinstatement by priming injections of cocaine after extinction.** *Behavioral Brain Research* 115:39-47.
- Mueller D, Perdikaris D, Stewart J (2002) **Persistence and drug-induced reinstatement of a morphine-induced conditioned place preference.** *Behavioral Brain Research* 135:389-397.
- Naie K, Manahan-Vaughan D (2005) **Investigations of the protein synthesis dependency of mGluR-induced long-term depression in the dentate gyrus of freely moving rats.** *Neuropharmacology Supplement* 49:35–44.
- Napier TC, Herrold AA, de Wit H (2013) **Using conditioned place preference to identify relapse prevention medications.** *Neuroscience & Biobehavioral Reviews*, Available online 13 May 2013.
- Navakkode S, Sakijumar S, Frey JU (2004) **The type IV-specific phosphodiesterase inhibitor rolipram and its effects on hippocampal long-term potentiation and synaptic tagging.** *The Journal of Neuroscience* 24: 7740–7744.
- Nguyen PV, Abel T, Kandel ER (1994) **Requirement for a critical period of transcription for induction of a late phase of LTP.** *Science* 265:1104–1107.

- Nguyen PV, Duffy SN, Young JZ (2000) **Differential maintenance and frequency-dependent tuning of LTP at hippocampal synapses of specific strains of inbred mice.** *The Journal of Neurophysiology* 84:2484–2493.
- Nicholls JG, Martin AR, Wallace BG, Fuchs PA (2001) **From neuron to brain: cellular approach to the function of the nervous system**, 4th ed. Sunderland, MA: Sinauer.
- Nicoll RA, Malenka RC (1999) **Expression mechanisms underlying NMDA receptor-dependent long-term potentiation.** *Annals of the New York Academy of Sciences USA* 868:515-525.
- Nowak L, Bregestovski P, Ascher P, Herbet A, Prochiantz A (1984) **Magnesium gates glutamate-activated channels in mouse central neurones.** *Nature* 307:462–465.
- Nyakas C, Luiten PGM, Spencer DG, Traber J (1987) **Detailed projection patterns of septal and diagonal band efferents to the hippocampus in the rat with emphasis on innervation of CA1 and dentate gyrus.** *Brain Research Bulletin* 18:533–545.
- O'Dell TJ, Kandel ER, Grant SG (1991) **Long-term potentiation in the hippocampus is blocked by tyrosine kinase inhibitors.** *Nature* 353:558–560.
- O'Keefe J, Dostrovsky J (1971) **The hippocampus as a spatial map: preliminary evidence from unit activity in the freely-moving rat.** *Brain Research* 34:171–175.
- O'Keefe J, Nadel L (1978) **The hippocampus as a cognitive map.** Oxford University Press:Oxford.
- Okada M, Onodera K, van Renterghem C, Sieghart W, Takahashi T (2000) **Functional correlation of GABA(A) receptor alpha subunits expression with the properties of IPSCs in the developing thalamus.** *The Journal of Neuroscience* 20:2202-2208
- Opazo P, Watabe AM, Grant SG, O'Dell TJ (2003) **Phosphatidylinositol 3-kinase regulates the induction of long-term potentiation through extracellular signal-related kinase-independent mechanisms.** *The Journal of Neuroscience* 23:3679–3688.
- Orsini C, Bonito-Oliva A, Conversi D, Cabib S (2005) **Susceptibility to conditioned place preference induced by addictive drugs in mice of the C57BL/6 and DBA/2 inbred strains.** *Psychopharmacology* 181:327–336.

- Ostroff LE, Fiala JC, Allwardt B, Harris KM (2002) **Polyribosomes redistribute from dendritic shafts into spines with enlarged synapses during LTP in developing rat hippocampal slices.** *Neuron* 35:535–545.
- Palmer MJ, Irving AJ, Seabrook GR, Jane DE, Collingridge GL (1997) **The group I mGlu receptor agonist DHPG induces a novel form of LTD in the CA1 region of the hippocampus.** *Neuropharmacology* 36:1517–1532.
- Palmer MJ, Isaac JTR, Collingridge GL (2004) **Multiple, developmentally Regulated Expression Mechanisms of Long-Term Potentiation at CA1 Synapses.** *The Journal of Neuroscience* 24:4903-4911.
- Pan WX, Schmidt R, Wickens JR, Hyland BI (2005). **Dopamine cells respond to predicted events during classical conditioning: evidence for eligibility traces in the reward-learning network.** *The Journal of Neuroscience* 25:6235–6278.
- Pang K, Rose GM (1989) **Differential effects of methionine5-enkephalin on hippocampal pyramidal cells and interneurons.** *Neuropharmacology* 28:1175-1181.
- Parker LA (1992) **Place conditioning in a three- or four-choice apparatus: role of stimulus novelty in drug-induced place conditioning.** *Behavioral Neuroscience* 106:294-306.
- Peng Y, Zhao J, Gu QH, Chen RQ, Xu Z, Yan JZ, Wang SH, Liu SY, Chen Z, Lu W (2010) **Distinct trafficking and expression mechanisms underlie LTP and LTD of NMDA receptor-mediated synaptic responses.** *Hippocampus* 20:646–658.
- Petralia RS (2012) **Distribution of Extrasynaptic NMDA Receptors on Neurons.** *The Scientific World Journal* 2012:267120.
- Phillips PE, Stuber GD, Heien ML, Wightman RM, Carelli RM (2003) **Sub-second dopamine release promotes cocaine seeking.** *Nature* 422:614–618.
- Pi HJ, Otmakhov N, El Gaamouch F, Lemelin D, De Koninck P, Lisman J (2010) **CaMKII control of spine size and synaptic strength: role of phosphorylation states and nonenzymatic action.** *Proceedings of the National Academy of Sciences USA* 107:14437–14442.
- Piskorowski RA, Chevalyere V (2012) **Synaptic integration by different dendritic compartments of hippocampal CA1 and CA2 pyramidal neurons.** *Cell Mol. Life Sci.* 69:75-88.

- Pitkänen A, Pikkarainen M, Nurminen N, Ylinen A (2000) **Reciprocal connections between the amygdala and the hippocampal formation, perirhinal cortex, and postrhinal cortex in rat. A review.** *Annals of the New York Academy of Sciences* 911:369-391.
- Plant K, Pelkey KA, Bortolotto ZA, Morita D, Terashima A, McBain CJ, Collingridge GL, Isaac JT (2006) **Transient incorporation of native GluR2-lacking AMPA receptors during hippocampal long-term potentiation.** *Nature Neuroscience* 9:602–604.
- Pollandt S, Liu J, Orozco-Cabal L, Grigoriadis DE, Vale WW, Gallagher JP, Shinnick-Gallagher P (2006) **Cocaine withdrawal enhances long-term potentiation induced by corticotropin-releasing factor at central amygdala glutamatergic synapses via CRF, NMDA receptors and PKA.** *The European Journal of Neuroscience* 24:1733–1743.
- Pouille F, Scanziani M (2004) **Routing of spike series by dynamic circuits in the hippocampus.** *Nature* 429:717–723.
- Prus AJ, James JR, Rosecrans JA (2009) **Chapter 4: Conditioned place preference.** In: Buccafusco JJ, ed. *Methods of Behavior Analysis in Neuroscience*. 2nd edition. Buccafusco JJ, editor. Boca Raton (FL): CRC Press.
- Pu L, Bao GB, Xu NJ, Ma L, Pei G (2002) **Hippocampal long-term potentiation is reduced by chronic opiate treatment and can be restored by re-exposure to opiates.** *The Journal of Neuroscience* 22:1914 –1921.
- Racca C, Stephenson AF, Streit PJ, Roberts DB, Somogyi P (2000) **NMDA Receptor Content of Synapses in Stratum Radiatum of the Hippocampal CA1 Area.** *The Journal of Neuroscience* 20:2512-2522.
- Rammes G, Zeilhofer HU, Collingridge GL, Parsons CG, Swandulla D (1999) **Expression of early hippocampal CA1 LTP does not lead to changes in AMPA-EPSC kinetics or sensitivity to cyclothiazide.** *Pflügers Archiv* 437:191–196.
- Ranck JB (1973) **Studies on single neurons in the dorsal hippocampal formation and septum in unrestrained rats. I. Behavioral correlates and firing repertoires.** *Experimental Neurology* 41:461–531.
- Redondo RL, Okuno H, Spooner PA, Frenguelli BG, Bito H, Morris RGM (2010) **Synaptic Tagging and Capture: Differential Role of Distinct Calcium/Calmodulin Kinases in Protein Synthesis-Dependent Long-Term Potentiation.** *The Journal of Neuroscience* 30:4981-4989.

- Reid LD, Marglin SH, Mattie ME, Hubbell CL (1989) **Measuring morphine's capacity to establish a place preference.** *Pharmacology Biochemistry and Behavior* 33:765-775.
- Renger JJ, Egles C, Liu G (2001) **A developmental switch in neurotransmitter flux enhances synaptic efficacy by affecting AMPA receptor activation.** *Neuron* 29:469-484.
- Rezayof A, Zarrindast MR, Sahraei H, Haeri-Rohani A (2003) **Involvement of Dopamine Receptors of the Dorsal Hippocampus on the Acquisition and Expression of Morphine-Induced Place Preference in Rats.** *J Psychopharmacology* 17:415-423.
- Richter-Levin G, Canevari L, Bliss TV (1998) **Spatial training and high-frequency stimulation engage a common pathway to enhance glutamate release in the hippocampus.** *Learning and Memory* 4:445-450.
- Robbins TW, Everitt BJ (2002) **Limbic-Striatal Memory Systems and Drug Addiction.** *Neurobiology of Learning and Memory* 78:625–636.
- Roberts LA, Higgins MJ, O'Shaughnessy CT, Stone TW, Morris BJ (1996) **Changes in hippocampal gene expression associated with the induction of long-term potentiation.** *Molecular Brain Research* 42:23–127.
- Robinson TE, Berridge KC (2008) **The incentive sensitization theory of addiction: some current issues.** *Philosophical Transactions of the Royal Society B: Biological Sciences* 363:3137-3146.
- Roche KW, O'Brien RJ, Mammen AL, Bernhardt J, Huganir RL (1996) **Characterization of multiple phosphorylation sites on the AMPA receptor GluR1 subunit.** *Neuron* 6:1179–1188.
- Roitman MF, Stuber GD, Phillips PE, Wightman RM, Carelli RM (2004) **Dopamine operates as a subsecond modulator of food seeking.** *The Journal of Neuroscience* 24:1265–1271.
- Roma PG, Riley AL (2005) **Apparatus bias and the use of light and texture in place conditioning.** *Pharmacology Biochemistry and Behavior* 82:163-169.
- Rozov A, Sprengel R, Seeburg PH (2012) **GluA2-lacking AMPA receptors in hippocampal CA1 cell synapses: evidence from gene-targeted mice.** *Frontiers in Molecular Neuroscience* 5:22.
- Saal D, Dong Y, Bonci A, Malenka RC (2003) **Drugs of Abuse and Stress Trigger a Common Synaptic Adaptation in Dopamine Neurons.** *Neuron* 37:577–582.

- Sacktor TC (2008) **PKMzeta, LTP maintenance, and the dynamic molecular biology of memory storage.** Progress in Brain Research 169:27-40.
- Sainsbury RS, Heynen A, Montoya CP (1987) **Behavioral correlates of hippocampal type 2 theta in the rat.** Physiology & Behavior 39:513–519.
- Salmanzadeh F, Fathollahi Y, Semnanian S, Shafizadeh M (2003) **Dependence on morphine impairs the induction of long-term potentiation in the CA1 region of rat hippocampal slices.** Brain Research 965:108 –113.
- Samuels ER and Szabadi E (2008) **Functional Neuroanatomy of the Noradrenergic Locus Coeruleus: Its Roles in the Regulation of Arousal and Autonomic Function Part I: Principles of Functional Organisation** Current Neuropharmacology 6: 235–253
- Sanchis-Segura C, Spanagel R (2006) **Behavioural assessment of drug reinforcement and addictive features in rodents: an overview.** Addiction Biology 11:2-38.
- Satoh T, Nakai S, Sato T, Kimura M (2003) **Correlated coding of motivation and outcome of decision by dopamine neurons.** The Journal of Neuroscience 23:9913–9978.
- Schechter MD, Calcagnetti DJ (1998) **Continued trends in the conditioned place preference literature from 1992 to 1996: inclusive, with a cross-indexed bibliography.** Neuroscience & Biobehavioral Reviews 22:827–846.
- Schenk S, Ellison F, Hunt T, Amit Z (1985) **An examination of heroin conditioning in preferred and nonpreferred environments and in differentially housed mature and immature rats.** Pharmacology Biochemistry and Behavior 22:215–220.
- Schenk S, Horger BA, Peltier R, Shelton K (1991) **Supersensitivity to the reinforcing effects of cocaine following 6-hydroxydopamine lesions to the medial prefrontal cortex in rats.** Brain Research 543:227–235.
- Schilström B, Yaka R, Argilli E, Suvarna N, Schumann J, Chen BT, Carman M, Singh V, Mailliard WS, Ron D, Bonci A (2006) **Cocaine enhances NMDA receptor-mediated currents in ventral tegmental area cells via dopamine D5 receptor-dependent redistribution of NMDA receptors.** The Journal of Neuroscience 26:8549–8558.
- Schultz W (1998) **Predictive reward signal of dopamine neurons.** The Journal of Neurophysiology 80:1–27.

- Schultz W (2002) **Getting formal with dopamine and reward.** *Neuron* 36:241–278.
- Schultz W (2007) **Multiple dopamine functions at different time courses.** *Annual Review of Neuroscience* 30:259–288.
- Schultz W, Apicella P, Ljungberg T (1993) **Responses of monkey dopamine neurons to reward and conditioned stimuli during successive steps of learning a delayed response task.** *The Journal of Neuroscience* 13:900–978.
- Schultz W, Dayan P, Montague PR (1997) **A neural substrate of prediction and reward.** *Science* 275:1593-1599.
- Schulz PE, Cook EP, Johnston D (1994) **Changes in paired-pulse facilitation suggest presynaptic involvement in long-term potentiation.** *The Journal of Neuroscience* 14:5325-5337.
- Schulz PE, Cook EP, Johnston D (1994) **Changes in paired-pulse facilitation suggest presynaptic involvement in long-term potentiation.** *The Journal of Neuroscience* 14:5325–5337.
- Scoles MT, Siegel S (1986) **A potential role of saline trials in morphine-induced place preference conditioning.** *Pharmacology Biochemistry & Behavior* 25:1169-1173.
- Scoville WB, Milner B (1957) **Loss of recent memory after bilateral hippocampal lesions.** *Journal of Neurology, Neurosurgery & Psychiatry* 20:11–21.
- Semenova S, Kuzmin A, Zvartau E (1995) **Strain differences in the analgesic and reinforcing action of morphine in mice.** *Pharmacology Biochemistry and Behavior* 50:17–21.
- Serrano P, Friedman EL, Kenney J, Taubenfeld SM, Zimmerman JM, Hanna J, Alberini C, Kelley AE, Maren S, Rudy JW, Yin JC, Sacktor TC, Fenton AA (2008) **PKMzeta maintains spatial, instrumental, and classically conditioned long-term memories.** *PLoS Biology* 6:2698-2706.
- Sesack SR, Grace AA (2010) **Cortico-Basal Ganglia Reward Network: Microcircuitry.** *Neuropsychopharmacology* 35:27–47.
- Shaham Y, Erb S, Leung S, Buczek Y, Stewart J (1998) **CP-154,526, a selective, nonpeptide antagonist of the corticotropin-releasing factor1 receptor attenuates stress-induced relapse to drug seeking in cocaine- and heroin-trained rats.** *Psychopharmacology* 137:184–190.

- Sheline YI (2011) **Depression and the hippocampus: cause or effect?** Biol. Psychiatry 70(4):308-309.
- Shen HW, Toda S, Moussawi K, Bouknight A, Zahm DS, Kalivas PW (2009) **Altered dendritic spine plasticity in cocaine withdrawn rats.** The Journal of Neuroscience 29:2876–2884.
- Sheng M, Cummings J, Roldan LA, Jan YN, Jan LY (1994) **Changing subunit composition of heteromeric NMDA receptors during development of rat cortex.** Nature 368:144–147.
- Sheng M, Kim E (2012) **The postsynaptic organization of synapses.** Cold Spring Harbour Perspectives in Biology 3(12).
- Skinner BF (1938) **The Behavior of Organisms: An Experimental Analysis.** New York: Appleton-Century.
- Smith MA, Ellis-Davies GC, Magee JC (2003) **Mechanism of the distance-dependent scaling of Schaffer collateral synapses in rat CA1 pyramidal neurons** The Journal of Physiology 548:245-258.
- Solinas M, Thiriet N, Chauvet C, Jaber M (2010) **Prevention and treatment of drug addiction by environmental enrichment.** Progress in Neurobiology 92:572–592.
- Solinas M, Chauvet C, Thiriet N, El Rawas R, Jaber M (2008) **Reversal of cocaine addiction by environmental enrichment.** Proceedings of the National Academy of Sciences 105:17145-17150.
- Sorg BA (2012) **Reconsolidation of drug memories.** Neuroscience & Biobehavioral Reviews 36:1400–1417.
- Squire LR, Stark CE, Clark RE (2004) **The medial temporal lobe.** Annual Reviews in Neuroscience 27:279-306.
- Stanton PK, Heinemann U, Muller W (2001) **FM1-43 imaging reveals cGMP-dependent long-term depression of presynaptic transmitter release.** The Journal of Neuroscience 21:RC167.
- Stark CEL, Squire LR (2000b) **Recognition memory and familiarity judgments in severe amnesia: no evidence for a contribution of repetition priming.** Behavioral Neuroscience 114:459–467.
- Stäubli U, Perez Y, Xu FB, Rogers G, Ingvar M, Stone-Elander S, Lynch G (1994a) **Centrally active modulators of glutamate (AMPA) receptors facilitate the induction of LTP *in vivo*.** Proceedings of the National Academy of Sciences USA. 91:11158–11162.

- Staubli U, Rogers G, Lynch G (1994b) **Facilitation of glutamate receptors enhances memory.** Proceedings of the National Academy of Sciences USA. 91:777-781.
- Staubli U, Xu FB (1995) **Effects of 5-HT₃ receptor antagonism on hippocampal theta rhythm, memory and LTP induction in the freely moving rat.** The Journal of Neuroscience Methods 15:2445–2452.
- Steketee JD, Kalivas PW (2011) **Drug Wanting: Behavioral Sensitization and Relapse to Drug-Seeking Behavior.** Pharmacological Reviews 63:348–365.
- Stramiello M, Wagner JJ (2008) **D1/5 receptor-mediated enhancement of LTP requires PKA, Src family kinases, and NR2B-containing NMDARs.** Neuropharmacology 55:871-877.
- Stuart G, Spruston N, Sakmann B, Hausser M (1997) **Action potential initiation and backpropagation in neurons of the mammalian CNS.** Trends in Neurosciences 20:125–131.
- Stuber GD, Klanker M, de Ridder B, Bowers MS, Joosten RN, Feenstra MG, Bonci A (2008) **Reward-predictive cues enhance excitatory synaptic strength onto midbrain dopamine neurons.** Science 321:1690–1692.
- Sweatt JD (2004) **Mitogen-activated protein kinases in synaptic plasticity and memory.** Current Opinion in Neurobiology. 14:311–317.
- Taepavarapruk P, Phillips AG (2003) **Neurochemical correlates of relapse to d-amphetamine self-administration by rats induced by stimulation of the ventral subiculum.** Psychopharmacology 168:99-108
- Tamamaki N, Nojyo Y (1995) **Preservation of topography in the connections between the subiculum, field CA1, and the entorhinal cortex in rats.** Journal of Comparative Neurology 353:379–390.
- Teng E, Squire LR (1999) **Memory for places learned long ago is intact after hippocampal damage.** Nature 400:675–677.
- Thomas MJ, Beurrier C, Bonci A, Malenka RC (2001) **Long-term depression in the nucleus accumbens: a neural correlate of behavioral sensitization to cocaine.** Nature Neuroscience 4:1217–1223.
- Thomson AM (2000) **Facilitation, augmentation and potentiation at central synapses.** Trends in Neurosciences 23:305–312.
- Tobler PN, Fiorillo CD, Schultz W (2005) **Adaptive coding of reward value by dopamine neurons.** Science 307:1642–1678.

- Tomita S, Stein V, Stocker TJ, Nicoll RA, Brecht DS (2005) **Bidirectional Synaptic Plasticity Regulated by Phosphorylation of Stargazin-like TARPs** *Neuron* 45:269–277.
- Toni N, Buchs PA, Nikonenko I, Povilaitite P, Parisi L, Muller D (2001) **Remodeling of Synaptic Membranes after Induction of Long-Term Potentiation**. *The Journal of Neuroscience* 21:6245-6251.
- Tsai HC, Zhang F, Adamantidis A, Stuber GD, Bonci A, de Lecea L, Deisseroth K (2009) **Phasic firing in dopaminergic neurons is sufficient for behavioral conditioning**. *Science* 324:1080–1084.
- Tzschentke TM (2000) **The medial prefrontal cortex as part of the brain reward system**. *Amino Acids* 91:211–278.
- Tzschentke TM (1998) **Measuring reward with the conditioned place preference paradigm: a comprehensive review of drug effects, recent progress and new issues**. *Progress in Neurobiology*. 56:613–678.
- Tzschentke TM, Schmidt WJ (1995) **N-methyl-D-aspartic acid-receptor antagonists block morphine-induced conditioned place preference in rats**. *Neuroscience Letters* 193:37–40.
- Ungless MA, Whistler JL, Malenka RC, Bonci A (2001) **Single cocaine exposure *in vivo* induces long-term potentiation in dopamine neurons**. *Nature* 411:583-587.
- Van den Oever MC, Goriounova NA, Li KW, Van der Schors RC, Binnekade R, Schoffelmeer AN, Mansvelder HD, Smit AB, Spijker S, De Vries TJ. (2008) **Prefrontal cortex AMPA receptor plasticity is crucial for cue-induced relapse to heroin-seeking**. *Nature Neuroscience* 11:1053-1058
- Van den Oever MC, Spijker S, Smit AB (2012) **The synaptic pathology of drug addiction**. *Advances in Experimental Medicine and Biology* 970:469-491
- Van den Oever MC, Spijker S, Smit AB, De Vries TJ (2010) **Prefrontal cortex plasticity mechanisms in drug seeking and relapse**. *Neuroscience & Biobehavioral Reviews* 35:276-284.
- Van Groen T, Miettinen P, Kadish I (2003), **The entorhinal cortex of the mouse: Organization of the projection to the hippocampal formation**. *Hippocampus* 13:133–149.
- Vanderwolf CH (1969) **Hippocampal electrical activity and voluntary movement in the rat**. *Electroencephalography and Clinical Neurophysiology* 26:407–418.

- Volk LJ, Bachman JL, Johnson R, Yu Y, Huganir RL (2013) **PKM- ζ is not required for hippocampal synaptic plasticity, learning and memory.** *Nature* 493:420-423.
- Weissenborn R, Robbins TW, Everitt BJ (1997) **Effects of medial prefrontal or anterior cingulate cortex lesions on responding for cocaine under fixed-ratio and second-order schedules of reinforcement in rats.** *Psychopharmacology* 134:242–257.
- Welch BL (1947) **The generalization of "Student's" problem when several different population variances are involved.** *Biometrika* 34:28–35.
- Wenthold RJ, Prybylowski K, Standley S, Sans N, Petralia RS (2003) **Trafficking of NMDA receptors.** *Annual Reviews in Pharmacology and Toxicology* 43:335–358.
- West PJ, Marcy VR, Marino MJ, Schaffhauser H (2009) **Activation of the 5-HT(6) receptor attenuates long-term potentiation and facilitates GABAergic neurotransmission in rat hippocampus.** *Neuroscience* 164:692-701.
- White FJ (1996) **Synaptic regulation of mesocorticolimbic dopamine neurons.** *Annual Review of Neuroscience* 19:405–436.
- Whitlock JR, Heynen AJ, Shuler MG, Bear MF (2006) **Learning induces long-term potentiation in the hippocampus.** *Science* 313:1093-7.
- Wilson RI, Nicoll RA (2002) **Endocannabinoid signaling in the brain.** *Science* 296:678–682.
- Wise RA (1982) **Neuroleptics and operant behavior: the anhedonia hypothesis.** *Behavioral Brain Science* 5:39–78.
- Wu-Zhang AX, Schramm CL, Nabavi S, Malinow R, Newton AC (2012) **Cellular Pharmacology of Protein Kinase M ζ (PKM ζ) Contrasts with Its in Vitro Profile: Implications for PKM ζ as a mediator of memory.** *The Journal of Biological Chemistry* 287:12879-12885.
- Wyllie DJ, Nicoll RA (1994) **A role for protein kinases and phosphatases in the Ca(2)-induced enhancement of hippocampal AMPA receptor-mediated synaptic responses.** *Neuron* 13:635–643.
- Xu NJ, Yu YX, Zhu JM, Liu H, Shen L, Zeng R, Zhang X, Pei G (2004) **Inhibition of SNAP-25 Phosphorylation at Ser187 Is Involved in Chronic Morphine-induced Down-regulation of SNARE Complex Formation.** *The Journal of Biological Chemistry* 279:40601-40608.

- Yang Q, Liao ZH, Xiao YX, Lin QS, Zhu YS, Li ST (2011) **Hippocampal synaptic metaplasticity requires the activation of NR2B-containing NMDA receptors.** Brain Research Bulletin 84:137-143.
- Yashiro K, Philpot BD (2008) **Regulation of NMDA receptor subunit expression and its implications for LTD, LTP, and metaplasticity.** Neuropharmacology 55:1081–1094.
- Yasuda H, Barth AL, Stellwagen D, Malenka RC (2003) **A developmental switch in the signaling cascades for LTP induction.** Nature Neuroscience 6:15–16.
- Yoon EJ, Gerachshenko T, Spiegelberg BD, Alford S, Hamm HE (2007) **Gbetagamma interferes with Ca²⁺-dependent binding of synaptotagmin to the soluble N-ethylmaleimide-sensitive factor attachment protein receptor (SNARE) complex.** Molecular Pharmacology 72:1210-1219.
- Zakharenko SS, Zablow L, Siegelbaum SA (2001) **Visualization of changes in presynaptic function during long-term synaptic plasticity.** Nature Neuroscience 4:711-717.
- Zhou W, Kalivas PW (2008) **N-acetylcysteine reduces extinction responding and induces enduring reductions in cue- and heroin-induced drug-seeking.** Biological Psychiatry 63:338–340.
- Ziv Y, Burns LD, Cocker ED, Hamel EO, Ghosh KK, Kitch LJ, El Gamal A, Schnitzer MJ (2013) **Long-term dynamics of CA1 hippocampal place codes.** Nature Neuroscience 16:264-266.
- Zucker RS, Regehr WG (2002) **Short-Term Synaptic Plasticity.** Annual Reviews in Physiology 64:355–405.
- Zweifel LS, Argilli E, Bonci A, Palmiter RD (2008) **Role of NMDA receptors in dopamine neurons for plasticity and addictive behaviors.** Neuron 59:486–496.