



Citation for published version:

Pelecanos, L, Kontoe, S & Zdravkovic, L 2012, 'Numerical Analysis of the Seismic Response of La Villita Dam in Mexico' Paper presented at 17th Biennial BDS (British Dam Society) Conference, Leeds, UK United Kingdom, 12/09/12 - 15/09/12, .

Publication date:

2012

Document Version

Publisher's PDF, also known as Version of record

[Link to publication](#)

University of Bath

General rights

Copyright and moral rights for the publications made accessible in the public portal are retained by the authors and/or other copyright owners and it is a condition of accessing publications that users recognise and abide by the legal requirements associated with these rights.

Take down policy

If you believe that this document breaches copyright please contact us providing details, and we will remove access to the work immediately and investigate your claim.

NUMERICAL ANALYSIS OF THE SEISMIC RESPONSE OF LA VILLITA DAM IN MEXICO

LOIZOS PELECANOS, Imperial College London, UK
STAVROULA KONTOE, Imperial College London, UK
LIDIJA ZDRAVKOVIĆ, Imperial College London, UK

SYNOPSIS. This paper presents two-dimensional plane-strain static and dynamic finite element analyses of La Villita earth dam in Mexico, which has experienced a number of large earthquakes. Static analyses are employed to simulate the layered construction of the embankment, water impounding and consolidation, whereas dynamic analyses simulate the earthquake events. The static behaviour of the dam is well captured, as evidenced by the predicted and recorded crest settlement. The dynamic behaviour is satisfactorily captured by comparing the accelerations recorded at both the crest and downstream berm of the dam.

INTRODUCTION

La Villita is a zoned earth dam located in the seismic region of Guerrero in Mexico. It has experienced 6 significant earthquakes between 1975 and 1985 and, although it did not fail, it sustained some permanent displacements. The most attractive feature of this case study is the asymmetry of the acceleration record of the crest of the dam which showed higher values of acceleration in the positive (downstream) direction. Previous studies using simple experimental sliding block models (Elgamal et al., 1990), three-dimensional shear beam analysis (Elgamal, 1992) and combined one-dimensional shear wedge and Newmark (1965) sliding block analysis (Succarieh et al., 1993) suggested that the observed asymmetry is due to a localised slope failure.

Moreover, visco-elastic FE analyses of the dam with a pre-defined perfectly-plastic sliding surface (i.e. sliding occurs when the acceleration exceeds the strength) were performed by Gazetas & Uddin (1994) and Uddin (1997) to investigate the observed response asymmetry. Two points on the two edges of the dam crest were monitored (one inside and one outside the sliding mass) and their response was compared, showing that the point inside the sliding mass presented an asymmetric acceleration response.

2 DAMS: ENGINEERING IN A SOCIAL & ENVIRONMENTAL CONTEXT

Finally, elastic and elasto-plastic, hybrid FE-shear beam analyses (Papalou & Bielak, 2001, 2004) of the dam with the surrounding canyon explored dam-canyon interaction effects.

In this investigation, new numerical analyses are carried out. Firstly, static coupled-consolidation FE analyses are performed, paying attention on the rigorous representation of the construction of the dam. Subsequently, dynamic analyses are undertaken to investigate the response of the dam during the seismic events.

LA VILLITA DAM

La Villita is a 60m high zoned earth dam in Mexico with a slightly curved crest about 420m long which is founded on an alluvium layer. The dam cross-section (Figure 1) is composed of a central clay core of very low permeability, with filters, transitions and outer rockfill shells. Alluvial deposits beneath the clay core were grouted to a depth of 26m below the dam, while there is also a 0.6m thick concrete cut-off wall to control seepage through the alluvium below the dam. Table 1 lists the known material properties (after Elgamal, 1992).

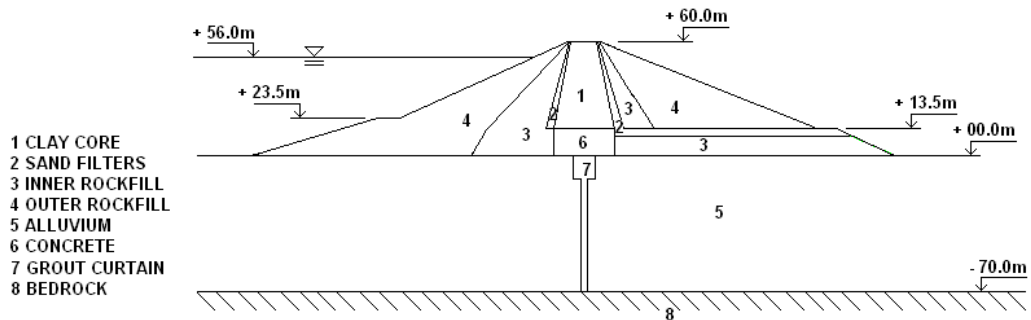

Figure 1: Cross-sectional view of La Villita dam

Table 1: Material properties of La Villita dam

No	Material	Density	Shear Wave Velocity	Cohesion	Angle of shearing
		ρ	V_s	c'	ϕ'
		Kg/m ³	m/s	kPa	deg
1	Clay core	2000	343	68	0
2	Sand filters	2180	307	0	35
3	Inner Rockfill	2080	314	0	45
4	Outer Rockfill	2080	280	0	45
5	Alluvium	2080	301	0	35

The dam experienced six major seismic events during the period between 1975 and 1985. The earthquake motions (Table 2) were recorded by three accelerometers which were installed on the dam soon after the end of the construction. There is one instrument on rock on the right bank and two on the dam body, at the crest and the downstream berm.

Table 2: Summary of the earthquake events

No	Date	Ms	Epic. dist	a _{max} of rock	a _{max} of crest
EQ1	11/10/1975	4.5	52km	0.07g	0.36g
EQ2	15/11/1975	5.9	10km	0.04g	0.21g
EQ3	14/3/1979	7.6	121km	0.02g	0.40g
EQ4	25/10/1981	7.3	31km	0.09g	0.43g
EQ5	19/11/1985	8.1	58km	0.12g	0.76g
EQ6	21/11/1985	7.5	61km	0.04g	0.21g

Not all acceleration records are available and also some of them contain only a part of the whole record. Elgamal (1992) states that due to instrument malfunction, only the bedrock records of 15 November 1975 (EQ2) and 19 November 1985 (EQ5) are useful for numerical analysis. Besides, the orientation of the instruments is convenient, as the two horizontal components are in the upstream-downstream (UD) and longitudinal (L) direction of the embankment.

NUMERICAL MODEL

Finite element (FE) analyses, employing the Imperial College Finite Element Program (ICFEP) (Potts & Zdravkovic, 1999), were performed to analyse the response of the dam. The FE mesh (Figure 2) consists of 6254 eight-noded isoparametric quadrilateral elements and 19143 nodes. Elements belonging to consolidating materials (clay core and riverbed alluvium) have also pore water pressure degrees of freedom in corner nodes. The maximum element size (4m) was chosen to be smaller than 1/5 of the smaller wavelength (Kuhlemeyer & Lysmer, 1973). The bottom boundary of the mesh was placed at the interface between the foundation alluvium and the bedrock, while the lateral boundaries were placed sufficiently far, so that interaction between them and the dam is avoided.

The constitutive model used in all the analyses is a cyclic nonlinear model, which adopts a logarithmic function to describe the backbone curve (Puzrin & Shiran, 2000; Taborda et al, 2010; Taborda, 2011) coupled with a Mohr-Coulomb failure criterion. The logarithmic relation (Equation 1) dictates the degradation of shear stiffness, G_{max} , and the increase of damping, ξ , with cyclic shear strain, γ .

$$J^* = E_d^* G_{max} \left\{ 1 - \alpha \left[\ln \left(1 + \frac{E_d^* G_{max}}{J_L} \right) \right]^R \right\} \quad \text{Eq. 1}$$

4 DAMS: ENGINEERING IN A SOCIAL & ENVIRONMENTAL CONTEXT

where J^* and E_d^* are the three-dimensional stress and strain invariants respectively, G_{max} is the maximum shear stiffness, whereas α , J_L and R are model parameters (see also Taborda (2011)).

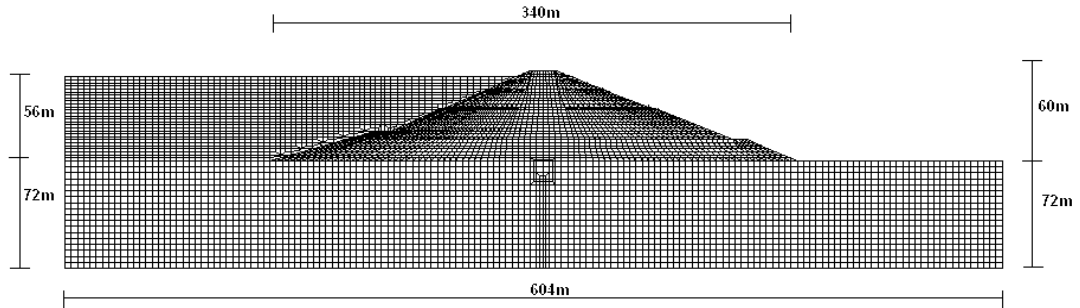

Figure 2: FE mesh of La Villita dam

Due to lack of experimental data, the cyclic nonlinear model (CNL) was calibrated (see Table 3 and Figures 3 & 4) on empirical relations. The Vucetic & Dobry (1991) curves were used for the clay core, whereas the curves of Seed et al (1986) were used for the rest of the materials.

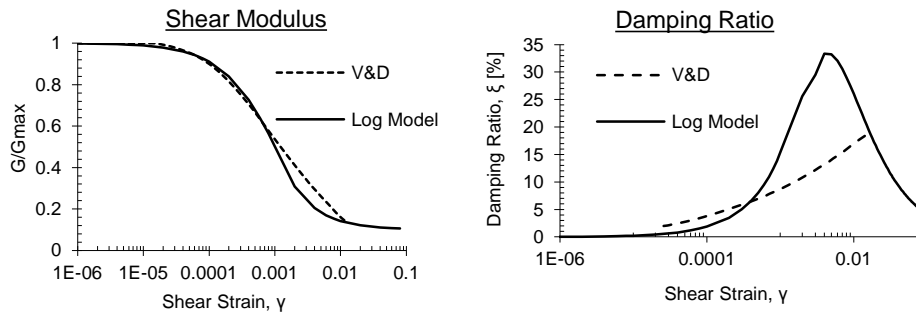

Figure 3: Calibration of the CNL model for the clay core

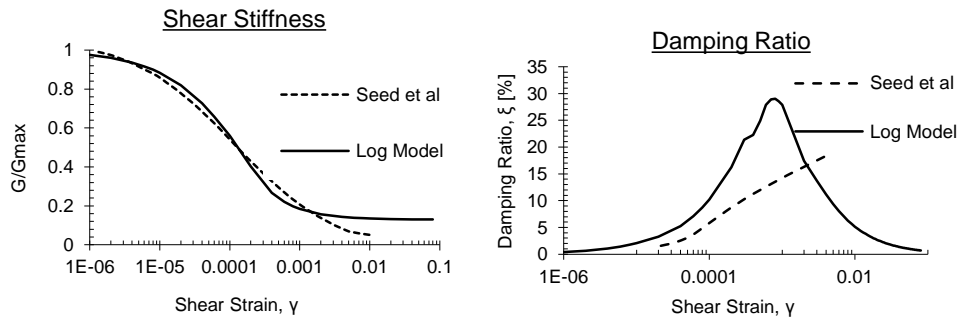

Figure 4: Calibration of the CNL for the coarse materials

Table 3: Results of the calibration of the CNL model

Material	E_{dL}	J_L	c
Clay core	0.007	290	1
Coarse materials	0.0015	65	1

STATIC ANALYSIS

Two-dimensional static coupled-consolidation analyses were performed in order to model the history of the dam prior to the earthquake events. First, layered construction is modelled over one year (1967), followed by one year of consolidation (1968). Then, water impoundment is simulated over six months (first six months of 1969) followed by another long period of consolidation (6.5 years: mid 1969 - late 1975) before the first seismic event. For the boundary conditions (BCs), in all the static analyses, zero horizontal and vertical displacements were prescribed along the bottom boundary, whereas zero horizontal displacement and vertical force were prescribed on the lateral boundaries. For the hydraulic BCs, zero change in pore water pressure (PWP) was specified along the lateral boundaries, apart from the water impounding stage, during which PWP increments were prescribed on the upstream boundary, according to the new hydrostatic distribution. The precipitation BC was prescribed on both sides of the clay core. This allowed water flow from the core outwards with zero PWP specified on the boundary whenever the PWP was higher in the core and also zero flow in the core whenever the PWP was higher out of the core (i.e. at places where suction existed in the core).

Water impoundment was modelled in two ways: (a) by applying a hydrostatic boundary stress (BS) on the upstream face and alluvium (i.e. the water finite elements as shown in Figure 2 are not activated and not used) and (b) by modelling the reservoir water with finite elements (WFE). In the latter case, the water elements were assigned the bulk modulus of water and a very small shear modulus for numerical stability.

Figure 5 shows the settlement of the crest using both approaches for modelling the reservoir water, BS and WFE. Figure 6 shows the pore water pressure distribution in the dam after water impoundment following the WFE approach. There is a tension-positive convention in ICFEP, and therefore the negative values correspond to compressive pore water pressure, whereas the positive values correspond to tensile pressure (i.e. suction). There is a hydrostatic distribution in the upstream part of the dam following the reservoir impounding and the pore pressure drops quickly within the core. It is clearly shown that the very small permeability of the clay core significantly minimizes the seepage. This confirms that the static part of the analysis (construction and impounding) is satisfactorily captured

6 DAMS: ENGINEERING IN A SOCIAL & ENVIRONMENTAL CONTEXT

with the appropriate stress conditions necessary for the subsequent dynamic analysis. The pore water pressure distribution for the analyses with the BS approach is very similar. However, by comparing the predicted and recorded crest settlements (Figure 5) it seems that the WFE approach can better predict the crest settlements during water impounding and subsequent consolidation than the BS approach.

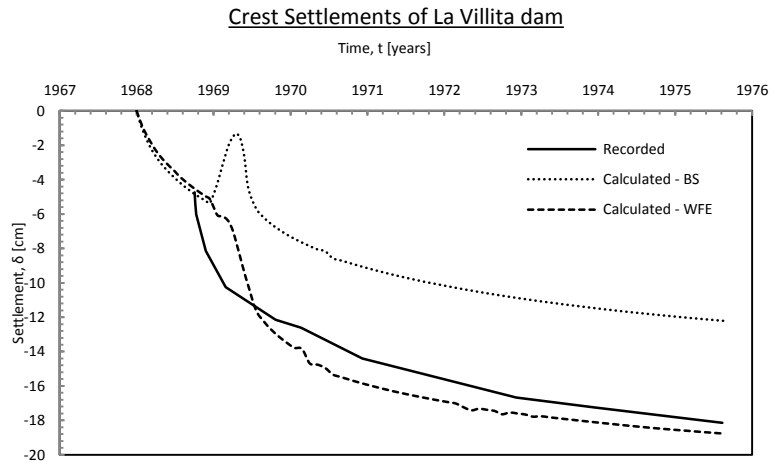

Figure 5: Observed and predicted displacement of the dam crest

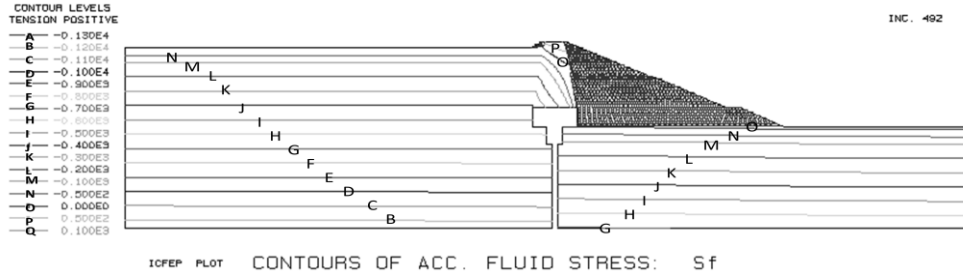

Figure 6: Pore water pressure distribution [kPa] after water impoundment for the analysis with the WFE approach.

DYNAMIC ANALYSIS

After the static analyses finished and the appropriate stress conditions in the dam and foundation soil were obtained, dynamic analyses were carried out to investigate the seismic performance of the dam. The rock records are used as input to the analyses. As it was mentioned earlier, Elgamal (1992) states that only EQ2 and EQ5 records are useful for numerical analysis and therefore, dynamic analyses were performed only for EQ2 and EQ5. In both events the reservoir water pressures were modelled in the two ways mentioned earlier in the static analysis, i.e. the BS and WFE approaches.

The BCs along the bottom boundary were fixity in the vertical direction and prescribed values of acceleration in the horizontal. The lateral BCs on the alluvium were prescribed tied-degrees-of-freedom (TDOF) in both directions and zero vertical displacement on the reservoir. The time integration scheme adopted is the generalised- α algorithm of Chung & Hulbert (1993) (Kontoe, 2006).

Figures 7-9 show the recorded and calculated accelerations for both earthquakes (berm and crest for EQ2 and crest for EQ5) using the WFE approach. A better match is observed for the berm record of EQ2. It is worth mentioning that both reservoir-modelling approaches, BS and WFE, yield similar results. The calculated accelerations from the dynamic analysis generally show a good agreement with the recorded data, although the calculated values seem to be generally smaller. However, the high peaks of the response at the crest which have been previously attributed to a localised failure (Elgamal *et al.*, 1990, Gazetas & Uddin, 1997) were still not obtained. No failure was predicted in the dam during the seismic events in this study, and this is believed to be the reason that high peaks have not been obtained.

Furthermore, Figures 10-12 show the response spectra of the predicted and recorded accelerations at the crest and berm for EQ2 and EQ5. It is clear that the recorded spectral accelerations are generally larger than the predicted ones. The higher ordinates of the spectral acceleration for the recorded motion especially for EQ5 are believed to be originated from the high peaks found in the recorded acceleration motion and which are not included in the calculated accelerations. This is not surprising as the response spectra include only the peak values of the acceleration response for different fundamental periods. Therefore, the difference between the recorded and predicted spectra is due to the inability of the model to predict this localised failure and hence the asymmetric response. That is the reason why the difference is larger in the spectra of the crest records. Moreover, it may be observed from these spectra that there is no great difference between the results of the two approaches as they both give similar results.

It may be observed from the deformed mesh after the end of EQ5 (Figure 13) that no major failure seems to have taken place. Therefore, as failure of the dam is not predicted, asymmetry in the response is not expected to be obtained. Again, this is in agreement to the conclusion of the previous researchers (Elgamal *et al.*, 1990, Gazetas & Uddin, 1997) that only a localised failure occurred and not a global failure of the dam.

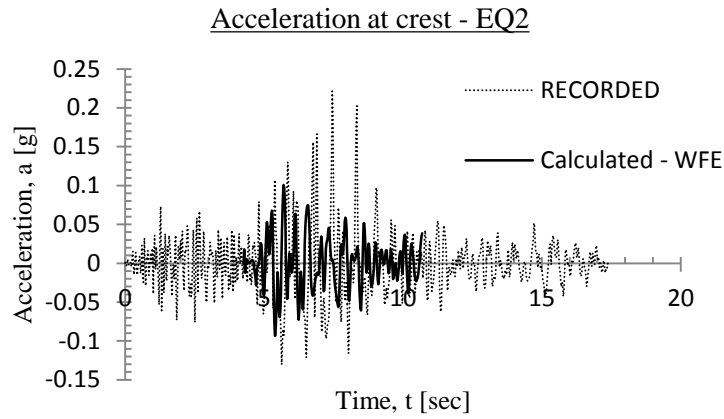

Figure 7: Recorded and calculated (WFE) accelerations at crest for EQ2

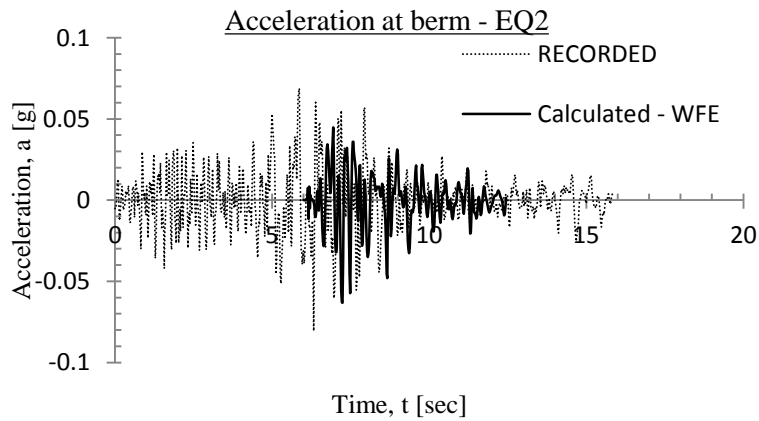

Figure 8: Recorded and calculated (WFE) accelerations at berm for EQ2

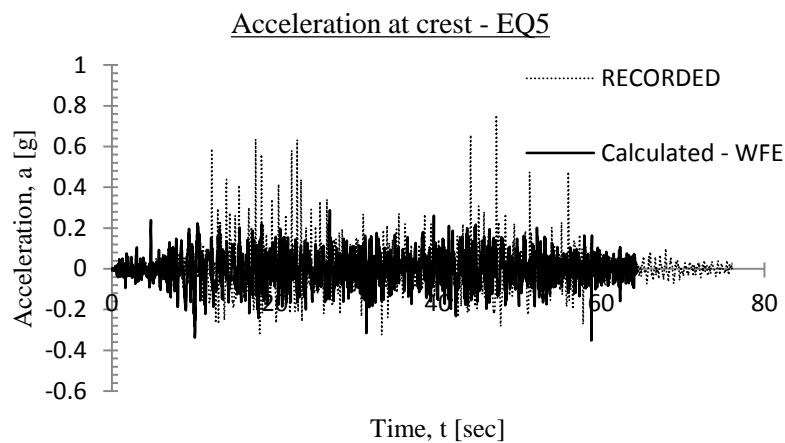

Figure 9: Recorded and calculated (WFE) accelerations at crest for EQ5

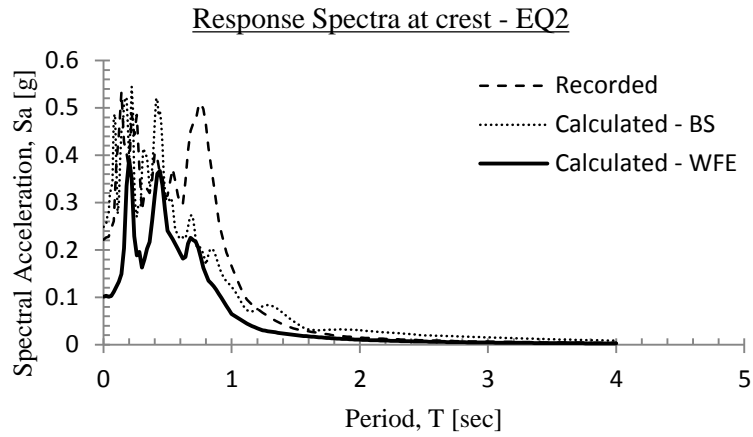

Figure 10: Response spectra of recorded and calculated (both BS & WFE) accelerations at crest for EQ2

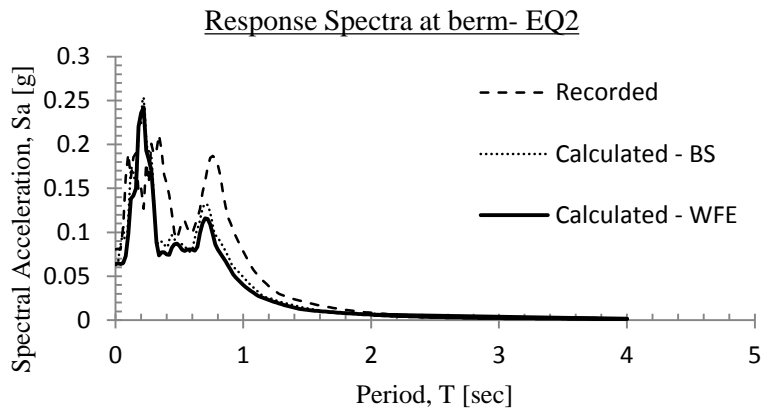

Figure 11: Response spectra of recorded and calculated (both BS & WFE) accelerations at berm for EQ2

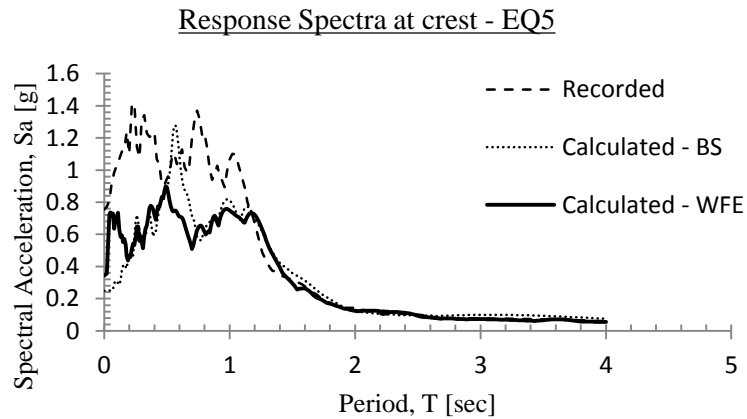

Figure 12: Response spectra of recorded and calculated (both BS & WFE) accelerations at crest for EQ5

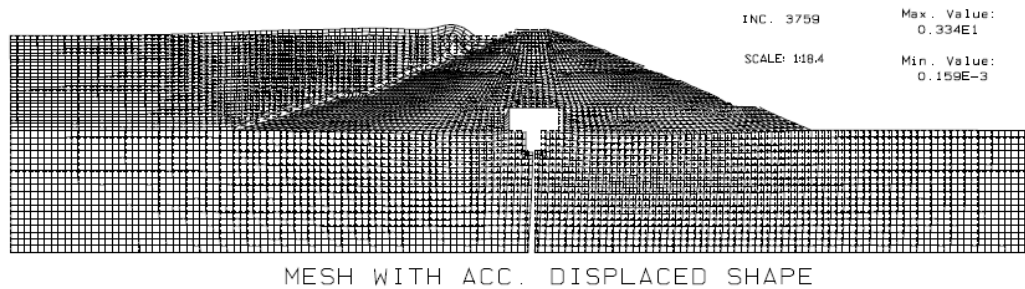

Figure 13: Deformed mesh after the end of EQ5 (Legend values are in meters)

CONCLUSION

La Villita is an earth dam in Mexico which has experienced a number of significant earthquakes during the period 1975-1985. Displacements and accelerations recorded during earthquakes are available, making the dam a well-documented case. In this study, static coupled consolidation and dynamic nonlinear finite element analyses have been performed in order to investigate the performance of the dam during earthquakes. The analyses show that during the static stage a good prediction was obtained for the crest settlements while during the dynamic stage, a good prediction was obtained for the crest and berm accelerations. No major failure in the dam during the seismic events has been predicted, as evidenced by the obtained crest accelerations and deformed mesh. Moreover, when the reservoir water is discretised with finite elements rather than with an applied boundary stress, a better prediction of the measured crest displacements is obtained for the static analyses. However, the predicted crest and berm accelerations do not differ significantly for both approaches in the dynamic part of the analysis.

ACKNOWLEDGEMENTS

The first author would like to express his acknowledgements to the Engineering and Physical Sciences Research Council (EPSRC), UK for the award of a Research Grant.

REFERENCES

- Chung, J. & Hulbert, G. M. (1993), A time integration algorithm for structural dynamics with improved numerical dissipation: the generalised- α method. *Journal of Applied Mechanics*, 60, 371-375.
- Elgamal, A. W., Scott, R. F., Succarieh, M. F., Yan, L. (1990), La Villita dam response during five earthquakes including permanent deformation. *Journal of Geotechnical Engineering*, 116 (10), 1443-1462.

Elgamal, A. W. (1992), Three-dimensional seismic analysis of La Villita dam. *Journal of Geotechnical Engineering*, 118 (12), 1937-1958.

Gazetas, G. & Uddin, N. (1994), Permanent deformation on pre-existing sliding surfaces in dams. *Journal of Geotechnical Engineering*, 120 (11), 2041-2061.

Newmark, N. M. (1965), Effects of earthquakes on dams and embankments. *Geotechnique*, 15 (2), 139-160.

Kontoe, S. (2006), *Development of time integration schemes and advanced boundary conditions for dynamic geotechnical analysis*, PhD thesis, Imperial College, University of London.

Kontoe, S., Zdravkovic, L., Potts, D. M. (2008), An assessment of time integration schemes for dynamic geotechnical problems. *Computers and Geotechnics*, 35 (2), 253-264.

Kuhlemeyer, R. L. & Lysmer, J. (1973), Finite element method accuracy for wave propagation problems. *Journal of Soil Mechanics and Foundation Division, ASCE*, 99(5), 421-427.

Papalou, A. & Bielak, J. (2001), Seismic elastic response of earth dams with canyon interaction. *Journal of Geotechnical and Geoenvironmental Engineering*, 127 (5), 446-453.

Papalou, A. & Bielak, J. (2004), Nonlinear seismic response of earth dams with canyon interaction. *Journal of Geotechnical and Geoenvironmental Engineering*, 130 (1), 103-110.

Potts, D. M. & Zdravkovic, L. (1999), *Finite element analysis in geotechnical engineering: theory*. Thomas Telford, London.

Potts, D. M. & Zdravkovic, L. (2001), *Finite element analysis in geotechnical engineering: application*. Thomas Telford, London.

Puzrin, A. M. & Shiran, A. (2000), Effects of the constitutive relationship on seismic response of soils. Part I: Constitutive modelling of cyclic behaviour of soils. *Soil Dynamics and Earthquake Engineering*, 19 (5), 305-318.

Seed, H. B., Wong, R. T., Idriss, I. M. & Tokimatsu, K. (1986), Moduli and damping factors for dynamic analyses of cohesionless soils. *Journal of Geotechnical Engineering*, 112 (11), 1016-1032.

Succarieh, M. F., Elgamal, A. W., Yan, L. (1993), Observed and predicted earthquake response of La Villita dam. *Engineering Geology*, 34 (93), 11-26.

Taborda, D. M. G., Zdravkovic, L., Kontoe, S., Potts, D. M. (2010), Alternative formulations for cyclic nonlinear elastic models: Parametric study and comparative analyses, in Proc. of *Numerical Methods in Geotechnical Engineering (NUMGE)*, Benz & Nordal (eds), Trodheim, Norway, 423-428.

Taborda, D. M. G. (2011), *Development of constitutive models for application in soil dynamics*, PhD thesis, Imperial College, University of London.

Uddin, N. (1997), A single step procedure for estimating seismically-induced displacements in earth structures. *Computers & Structures*, 64 (5/6), 1175-1182.

Vucetic, M. & Dobry, R. (1991), Effect of soil plasticity on cyclic response. *Journal of Geotechnical Engineering*, 117 (1), 87-107.