



Citation for published version:

Hernando Gil, I, Ilie, I-S & Djokic, SZ 2016, 'Reliability planning of active distribution systems incorporating regulator requirements and network-reliability equivalents', IET Generation, Transmission and Distribution, vol. 10, no. 1, pp. 93-106. <https://doi.org/10.1049/iet-gtd.2015.0292>

DOI:

[10.1049/iet-gtd.2015.0292](https://doi.org/10.1049/iet-gtd.2015.0292)

Publication date:

2016

Document Version

Peer reviewed version

[Link to publication](#)

© 2016 IEEE. Personal use of this material is permitted. Permission from IEEE must be obtained for all other users, including reprinting/ republishing this material for advertising or promotional purposes, creating new collective works for resale or redistribution to servers or lists, or reuse of any copyrighted components of this work in other works.

University of Bath

General rights

Copyright and moral rights for the publications made accessible in the public portal are retained by the authors and/or other copyright owners and it is a condition of accessing publications that users recognise and abide by the legal requirements associated with these rights.

Take down policy

If you believe that this document breaches copyright please contact us providing details, and we will remove access to the work immediately and investigate your claim.

Reliability Planning of Active Distribution Systems Incorporating Regulator Requirements and Network-Reliability Equivalents

Ignacio Hernando-Gil¹, Irinel-Sorin Ilie² and Sasa Z. Djokic²

¹Department of Electronic and Electrical Engineering, University of Bath, Bath BA2 7AY, UK

²Institute for Energy Systems, University of Edinburgh, King's Buildings, Mayfield Road, Edinburgh EH9 3JL, UK

Email: i.hernando.gil@bath.ac.uk

Abstract

This paper presents an integrated approach for reliability planning and risk estimation in active distribution systems. By incorporating the use of accurate reliability equivalents for different MV/LV networks and load subsectors, a probabilistic methodology is proposed to capture both power quality and reliability aspects in power system planning, which potentially avoids the underestimation of system's performance at bulk supply points. A 'time to restore supply' concept, based on security of supply legislation, is introduced to quantify the effect of different network functionalities such as the use of backup supply or automatic/manual reconfiguration schemes. The range of annual reliability indices reported by 14 network operators in the UK is also used for the validation of reliability results, which allows estimating the risk of interruption times above the Regulator-imposed limits. Accordingly, conventional reliability assessment procedures are extended in this paper by analysing a meshed urban distribution network through the application of a time-sequential Monte Carlo simulation. The proposed methodology also acknowledges the use of time-varying fault probabilities and empirical load profiles for a more realistic estimation of customer interruptions. A decision-making approach is shown by assessing the impact of several network actions on the accuracy of reliability performance results.

Keywords: power system reliability, security and quality of supply, distribution network, reliability equivalent, customer interruption.

1. Introduction

Deregulation and competition in the electricity market put a significant pressure on distribution network operators (DNOs) to improve reliability and continuity of the services they provide. Failure to deliver electrical energy on promises of better supply quality can result in severe financial penalties and may affect their ability to gain new or keep existing customers [1]. However, present

distribution systems are designed such that performance of medium voltage (MV) and low voltage (LV) networks have a dominant impact on the quality of service seen by end customers. In the UK, it is reported that about 90% of customer interruptions (CI) and 97% of customer minutes lost (CML) have their cause at voltages between 0.4 kV (i.e. LV) and 20 kV (i.e. MV) [2].

Energy Regulators impose annual continuity of supply targets for the frequency and duration of customer long interruptions (LIs), after which strategies for planning, operation and maintenance are designed. However, annual targets are only based on historical reliability records. DNOs report the reliability performance of their networks by using energy not supplied (ENS) index [3], and indices defined in accordance with [4]: system average interruption frequency index, SAIFI; system average interruption duration index, SAIDI; and momentary average interruption frequency index, MAIFI. Therefore, in order to limit the impact of supply outages on end-users, Energy Regulators develop incentive scheme targets [5], i.e. penalty/reward schemes under different performance standards [6] for the restoration of the interrupted supply. In this way, DNOs are required to compensate end-users in all cases when network reliability performance is out of the prescribed limits, considering also exceptional events such as severe weather conditions [7].

However, recent statistics suggest that current planning strategies are not successfully implemented when risk and reliability network performance is assessed. For example, more than 14% of DNOs in the UK have recently been penalised for not achieving CI limits, whereas 50% of them have not been able to meet CML targets [2]. This is worsened by the minimum overall level of accuracy for reporting number and duration of supply interruptions, which in the UK is set at 95% [8], allowing DNOs to omit from their reports the 5th percentile of the worst served customers.

Moreover, network modelling approaches often taken by DNOs, specially applied to active distribution systems, may not be adequate as they introduce high levels of uncertainties and, therefore, big errors between the estimated and actual reliability indices. This is confirmed in most of the reliability performance studies of large power systems, in which LV and MV parts (e.g. 0.4 kV and 11 kV networks in the UK) are simply represented by an aggregate/bulk load due to the

complexity of calculation. In addition, self-extinguishing and transient faults cleared by automatic switching, i.e. power quality (PQ)-related events that result only in short interruptions (SIs), are usually neglected during the reliability analysis [9]. This clearly confirms the need for the probabilistic methodology proposed in this paper, which by incorporating the use of accurate network-reliability equivalents and automatic switching functionalities is capable of integrating both PQ and reliability aspects in power system planning.

Within this context, the term ‘active distribution system’ denotes specific network management actions and functionalities that will have direct impact on the frequency and duration of long and short interruptions of supplied customers. These include implementation of remotely controlled system automation, switching and reconfiguration capabilities, as well as the provision of flexibility through the use of alternative supply points, aimed at improving reliability performance of both existing networks and future smart grids.

A time-limit concept, based on security and quality of supply (SQS) legislation, is also proposed in this paper to quantify the effect of different network functionalities such as the use of back-up supply or automatic/manual switching and restoration.

2. Security and regulator-imposed requirements for supply restoration times

As each DNO’s reliability performance and network characteristics (i.e. meshed or radial, urban or rural) strongly depend on the geographic location and supplied demand, the range of annual reliability indices reported by 14 DNOs in the UK (shown in Table 1) is used in this paper for the validation of reliability results. Accordingly, a highly meshed urban network would always be expected to offer minimum values (increased reliability), while a radial rural system would present maximum values (poor reliability).

Table 1. Annual values of UK DNOs’ reliability indices [2]

INDEX	UK DNOs’ Reports		
	min	mean	max
SAIFI (interruptions/customer/year)	0.29	0.71	1.19
SAIDI (hours/customer/year)	0.57	1.09	1.84
MAIFI (interruptions/customer/year)	0.15	0.78	3.3

2.1. Security and quality of supply requirements

After an interruption, the supply to electricity customers must be restored within a specified period of time. Therefore, time limits are defined as maximum durations required by SQS legislation to restore at least a minimum group demand of customers. The network configuration, protection schemes and repair process of the faulted network components are the main features which decide the duration of these interruptions. In the UK, six classes of supply (A to F) are defined in [10] based on group demand (GD) ranges, for which a maximum duration of interruptions is imposed, so that the minimum demand can be met. Table 2 specifies the required limits for supply restoration times, which in most of the cases are significantly shorter than the typical ‘mean time to repair’ (MTTR) values of power components.

Table 2. UK security of supply requirements for interrupted customers [10]

Class of Supply	Range of Group Demand (GD)	Minimum demands to be met after first circuit outage
A	$GD \leq 1 \text{ MW}$	In repair time: GD
B	$1 \text{ MW} < GD \leq 12 \text{ MW}$	(a) Within 3 h: GD - 1 MW (b) in repair time: GD
C	$12 \text{ MW} < GD \leq 60 \text{ MW}$	(a) Within 15 min: min GD - 12 MW; 2/3 GD (b) Within 3 h: GD
D	$60 \text{ MW} < GD \leq 300 \text{ MW}$	(a) Immediately: GD - up to 20 MW (b) Within 3 h: GD
E	$300 \text{ MW} < GD \leq 1500 \text{ MW}$	Immediately: GD
F	$GD > 1500 \text{ MW}$	According to transmission license security standard

It is important to note that each LI outside these limits (apart from exceptional events), and even though they do not accrue to specific penalties for DNOs, will progressively shift the overall network’s reliability performance outside the specified annual targets.

2.2. Duration of interruption requirements for electricity customers

In the UK, the Regulator specifies additional requirements for the duration of interruptions to protect electricity customers from excessive LI events. These requirements are introduced to protect those categories of customers that have no special contracts or agreements with the DNOs regarding the duration of interruptions (e.g. domestic/residential customers). Table 3 presents the maximum

admissible durations of interruptions, for up to and more than 5,000 customers [7], together with the corresponding penalties DNOs must pay directly to customers (not to the Regulator), if supply is not restored within the specified periods of time.

Table 3. UK regulator-imposed requirements for supply restoration times [7]

No. of Interrupted Customers	Maximum Duration to Restore Supply	Penalty paid to:	
		Domestic Customers	Non-Domestic Customers
Less than 5,000*	18 h	£54	£108
	After each succeeding 12 h	£27	£27
5,000* or more	24 h	£54	£108
	After each succeeding 12 h	£27	£27

*5,000 customers correspond to about 12 MW residential load.

3. Reliability equivalents of LV and MV distribution networks

Reliability indices calculated by conventional network modelling approaches are often inaccurate, as failures of power components in those parts of the system represented by bulk loads cannot be modelled correctly. Accordingly, if correct failure rates and repair times are allocated to a bus or substation where a bulk load is connected, an accurate reliability equivalent model can be formulated by simplifying the analysed large network and thus reducing simulation times.

Building up on the distribution network equivalents previously calculated in [11], this paper presents a general methodology for the calculation of accurate reliability equivalent models for different MV/LV distribution systems and load subsectors, ranging from metropolitan to rural areas. The methodology is based on recorded failure rates and mean repair times (i.e. MTTR) of those power components within the aggregate part of the system, and relevant UK SQS requirements (Table 2). The analytical approach proposed for reliability analysis of radial networks in [12] is extended in this paper to correctly analyse modern meshed networks with alternative supply points, for which supply restoration times are empirically determined. The accuracy of some of the calculated reliability equivalent models has been verified in [13]. Fig. 1 illustrates the theoretical concept for the aggregate LV and MV network models after the inclusion of reliability equivalents

at the bulk supply points (BSPs), where $Z_{eq,LV}$ and $Z_{eq,MV}$ represent their equivalent network impedances [11].

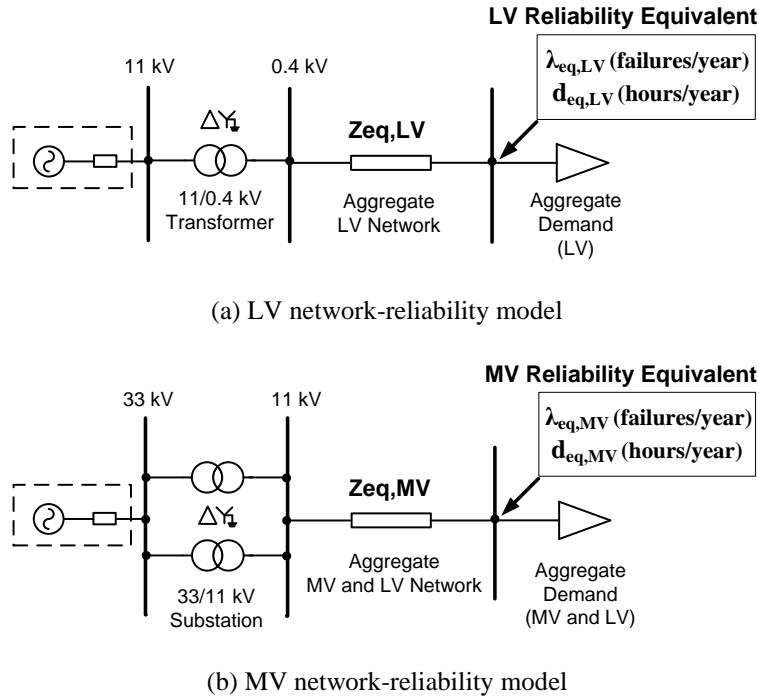

Fig. 1. Aggregate LV and MV network-reliability models

3.1. Input data for reliability equivalent modelling

Failure rates, λ , and mean repair times, d , are two basic inputs for reliability assessment, especially for Monte Carlo simulation (MCS), which first identifies all the components in the modelled network and their reliability characteristics. Thus, the equivalent failure rate (λ_{eq}) and equivalent repair time (d_{eq}) of the LV and MV buses where the bulk load is connected are derived from individual λ and d values, which are provided by a comprehensive database [14] for all relevant network components in the aggregate part of the system, as shown in Table 4. Further reliability data collected from an extensive literature survey for similar power components is provided in [15].

Table 4. Reliability data for main network components [14]

Power Component	Voltage Level (kV)	Failure Rate (failures/year)	Mean Repair Time (hours)
Overhead Lines	0.4	0.168 / km	5.7
	11	0.091 / km	9.5
	33	0.034 / km	20.5
	132	0.0038 / km	19.1
Cables	0.4	0.159 / km	6.9
	11	0.051 / km	56.2
	33	0.034 / km	201.6
	132	0.0277 / km	222.7
Transformers	11/0.4	0.002	75
	33/0.4	0.01	205.5
	33/11	0.01	205.5
	132/11	0.0392	250.1
	132/33	0.0392	250.1
	400/132	0.0392	250.1
Buses	0.4	0.005	24
	11	0.005	120
	>11	0.08	140
Circuit Breakers	0.4	0.005	36
	11	0.0033	120.9
	33	0.0041	140
	132	0.0264	98.4
	275	0.0264	98.4
	400	0.0264	98.4
Switch Fuses	11	0.0004	35.3

The equivalent failure rate, λ_{eq} (1), of the buses where the aggregate demand is connected can be calculated as the sum of the failure rates of all power components (i.e. N) in the LV or MV network. The equivalent repair time, d_{eq} (2), is calculated as the average value of all components' mean repair times. As a result, each reliability equivalent (λ_{eq} and d_{eq}) will consider the actual reliability performance of all power components (e.g. lines, transformers, buses, protections, etc.) downstream the point of aggregation (i.e. LV or MV aggregate buses in Fig. 1) and thus can be used for a more accurate calculation of the frequency and duration of interruptions within the lumped network.

$$\lambda_{eq} = \sum_{i=1}^N \lambda_i \quad (1)$$

$$d_{eq} = \frac{1}{N} \cdot \sum_{i=1}^N d_i \quad (2)$$

3.2. Reliability equivalent parameters with alternative supply

This methodology would only be applicable to those power components which interrupt a supplied group demand (GD) less or equal than 1 MW, as those outages are not required to comply with any SQS requirements (Table 2), and thus can be restored within the component repair time (i.e. MTTR values in Table 4). However, further attention should be allocated to those network components at MV level interrupting GDs larger than 1 MW, as SQS legislation requires customers with high power demands to be supplied with at least one backup supply point. As the duration of customer interruptions strongly depends on the actual configuration of power supply systems, highly-urban meshed networks will present a lower duration of interruptions than rural radial systems.

Depending on the interrupted bulk-supplied GD, different restoration times are required to restore supply after the first circuit outage (e.g. 15min, 3h, etc, according to UK SQS in Table 2). Therefore, the alternative supply concept is introduced in the calculation of the equivalent repair time, deq (2), for each subsector by allocating a SQS value to those components causing faults which interrupt a demand higher than 1 MW, 12 MW, etc, [10]. Instead of considering MTTR values to calculate the equivalent duration of interruptions of bulk loads by simply applying (2), the 'time to restore supply' (TTRS) concept will correctly assess the duration of interruptions in the equivalent systems.

Based on the detailed network models from highly-urban to rural areas in [11] and [16], Table 5 shows the calculated input parameters for the reliability aggregation of generic residential LV networks to be connected at the LV BSP in Fig. 1(a), as well as for precisely the MV part (i.e. 11 kV level) for each type of distribution system, and the combination of both of them (i.e. the whole network from 33 kV down to 0.4 kV) to be connected at the MV BSP in Fig. 1(b). Security of supply requirements are also provided for each type of distribution network considered.

Table 5. Reliability equivalent parameters per network and load subsector

Reliability Equivalent Model Parameters		FAILURE RATE (as in (1))	REPAIR TIME (as in (2) and [10])	Security of Supply Requirements [10]
		λ_{eq} (failures/year)	deq (hours/year)	
LV Distribution Networks (residential demand)	HU	4.31	16.6	(GD \leq 1 MW) to be met: in Repair Time
	U	2.51	17.5	
	SU	1.21	18	
	Ru	0.87	22	
MV Distribution Networks (from 1ary to 2ary substations)	HU	1.63	42.5	(GD > 1 MW and \leq 12 MW) to be met: within 3 h and (GD > 12 MW and \leq 60 MW) to be met: within 15 min
	U	2.26	45.9	
	SU	4.09	67.9	
	Ru	4.33	74.4	
Combined MV / LV Distribution Network (aggregate group demands)	HU	156.6	41.7	
	U	122.5	45.1	
	SU	57.1	67.4	
	Ru	33.7	74.2	

where: HU - highly urban, U - urban, SU - suburban, Ru - rural

Table 5 provides a cross-vector comparison among the SQS network performances from different load subsectors, and from LV to MV distribution systems. This is shown, for example, as values of deq increase from highly urban to rural areas, due to longer restoration times required in radial systems. On the other hand, the higher demand concentration in metropolitan areas and the higher number of installed components in meshed networks (especially at LV) make the values of λ_{eq} and so their fault probabilities to behave oppositely to deq . However, this trend on the λ_{eq} value is not applicable to the MV (11 kV) part of the distribution system (from primary to secondary substations), as the increased length of MV overhead lines (in comparison with more reliable MV underground cables) make the final failure rate (λ_{eq}) to increase from highly-urban to rural areas.

A preliminary validation of this concept was performed in [17], where the calculated reliability indices, e.g. CI and CML, were proved to offer a considerably small error of about 2%. The correct application of reliability equivalents will avoid the underestimation of reliability performance for the aggregate networks connected at LV/MV BSPs. Moreover, system complexity is significantly reduced as the electrical and reliability models of all network components no longer need to be represented in detail.

4. Criteria for risk and reliability analysis

There is a boundary defined when DNOs try to predict the dysfunctional behaviour of their systems, which is established by the load points at MV level. Neglecting outage events that occur within LV networks leads to unrealistic performance reports on continuity of supply. Moreover, linear regression methods, which rely on extrapolation of past network performances, should be avoided and replaced by simulation (i.e. probabilistic) based approaches.

Although many power system analyses currently use an analytical approach (e.g. network capacity planning), the need for probability techniques has been widely recognised in several studies (e.g. [18]), as they consider the full stochastic nature of system's behaviour, demand and components' faults. The decision-making methodology proposed in this paper applies time-sequential MCS [19-21], which is characterised by the chronological transitions of network components from "normal operation" states to "faulted" states, and vice versa [22-23].

4.1. Application of Monte Carlo simulation procedure

Based on previous developments of the presented MCS technique [15, 24], the operating and failure stages of network components are established through the use of a random generator, which is assigned to an inverse probability density function (PDF) [20] to convert component failure rates (λ) and MTTR values into system states. Accordingly, λ values are considered to follow an exponential distribution in this paper, while MTTR or TTRS values (depending on the GD interrupted) are modelled through Weibull's distribution, with the two corresponding scale/shape parameters (Rayleigh PDF) according to [25-26]. The simulation is incremented on a year by year time frame (in 40-year component's lifetime cycles) and stopped when convergence is met or 1000 years have passed. Every time a component fails to operate, a power flow algorithm is run to check and quantify the number of loads affected. The algorithm is implemented in Matlab/Python code, using PSSE software [27] to model the analysed distribution network. The main steps of the MCS approach used in this paper are summarised in Fig. 2.

The MCS methodology also acknowledges the use of time-varying fault probabilities and empirical load profiles for a more realistic assessment of customer interruptions. A residential load model [28] is selected to represent the demand at the network supply points, providing demand decomposition into different load types over the 24 hours of the day, and therefore affecting the values of both power factor (p.f.) and reactive power demand. Accordingly, a better correlation between the moment in time when a fault occurs in the system and the actual demand interrupted (i.e. not simply the rated power) will significantly improve the calculation accuracy of frequency and power/energy reliability indices (e.g. ENS index). The MCS procedure also considers to what extent the probability of network outages is affected by the overall system loading, hence the probability profiles of both SIs and LIs (i.e. time of the day when interruptions occurred) previously defined in [15] are incorporated in the MCS algorithm.

5. Reliability quantification of network functionalities through MCS

The proposed methodology aims to assess the impact of several network actions on the accuracy of reliability performance results. A decision-making approach is shown by comparing different scenarios and additions to the simulation procedure, up to the final state in which all possible network conditions are considered for an integrated reliability planning.

The network model for analysis is shown in Fig. 3, which is an underground MV/LV distribution network typically operated within UK interconnected urban areas [11]. Although underground MV networks present a meshed configuration, they normally operate radially with the support of another supply point, either a MV primary substation or a reflection centre offering a closed-loop arrangement that guarantees the supply in case of a N-1 failure. This is implemented by the cable '0', which is a feeder with no load in normal operation, connecting both ends of the network. Due to unexpected or planned maintenance operations, an automated protection arrangement [24] is also deployed to avoid the interruption of supply to customers. According to the criteria followed by DNOs in underground networks [29], tele-controlled circuit breakers (TCBs) and fault-detection

mechanisms are modelled in the 11 kV cables at both ends of the distribution system, i.e. between the supplying substation and reflection centre.

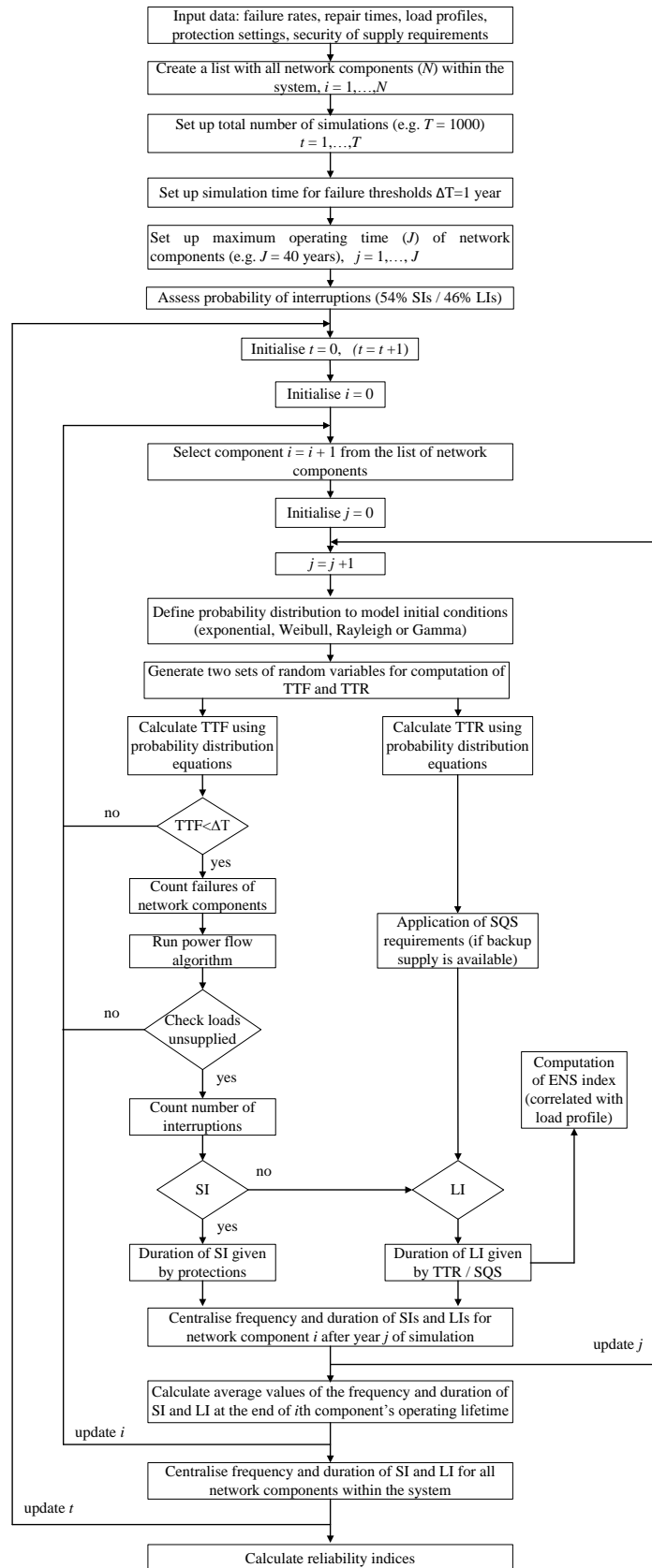

Fig. 2. General algorithm of the applied MCS procedure

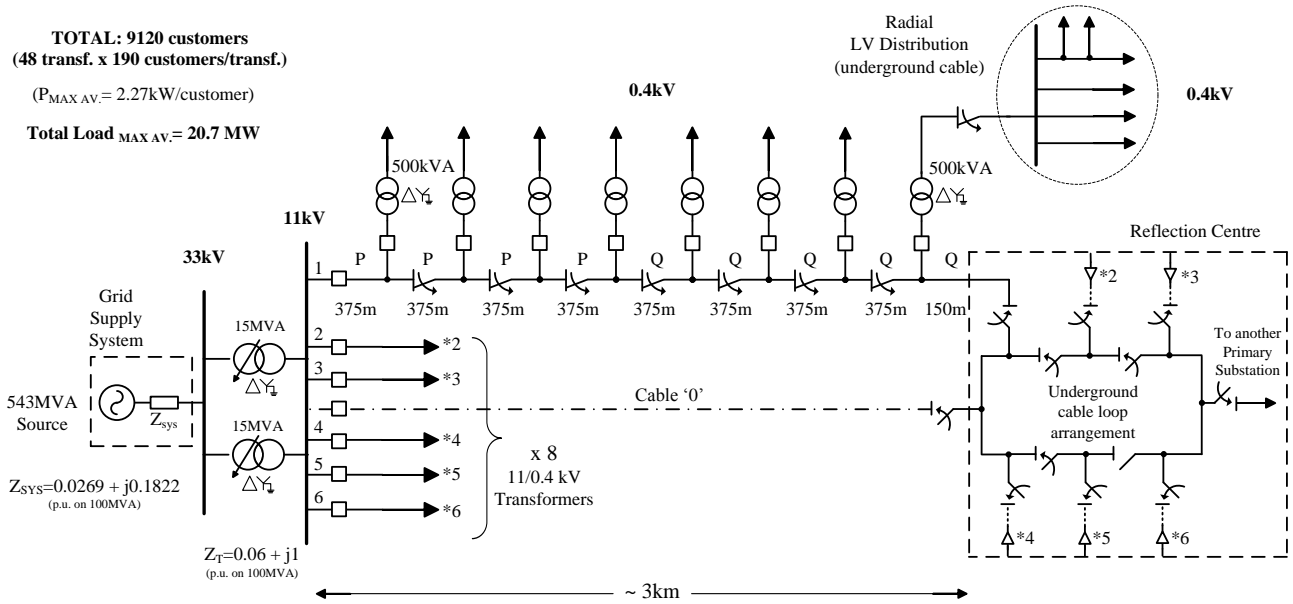

Fig. 3. Urban (residential) MV distribution network with underground cable meshed configuration

Initially, the MV network model in Fig. 3 supplies a total of 48 load points (i.e. BSPs), each of them supplied by a 500 kVA substation (11/0.4 kV transformer), and therefore representing the aggregate residential load of the equivalent LV networks connected at those nodes. The first set of scenarios will consider only the power supplied to those 48 aggregate loads (i.e. $48 \times 431.3 kW$ max); however, neglecting the events which occur within LV networks will lead to unrealistic reports on continuity of supply. The following scenarios will consider the detailed model of urban underground LV networks as an attempt to improve the accuracy of reliability results. Accordingly, all lumped load points in Fig. 3 (e.g. the dashed-circled part at 0.4 kV) will be represented with a detailed LV distribution system (purely residential demand), as presented in Fig. 4 [11].

As each LV network supplies a total of 19 load points (points of common coupling (PCC) for residential customers), now the total number of loads to track adds up to 912 (48×19 LV nodes), which will directly impact the reliability results, as the increased number of served loads will change the normalised values of the resulting indices. The loading conditions at each LV supply node in Fig. 4 are modelled as symmetrical, but as there is a different number of LV customers connected at each LV PCC, all results with LV equivalent networks are obtained “per LV load point”, not “per LV customer”.

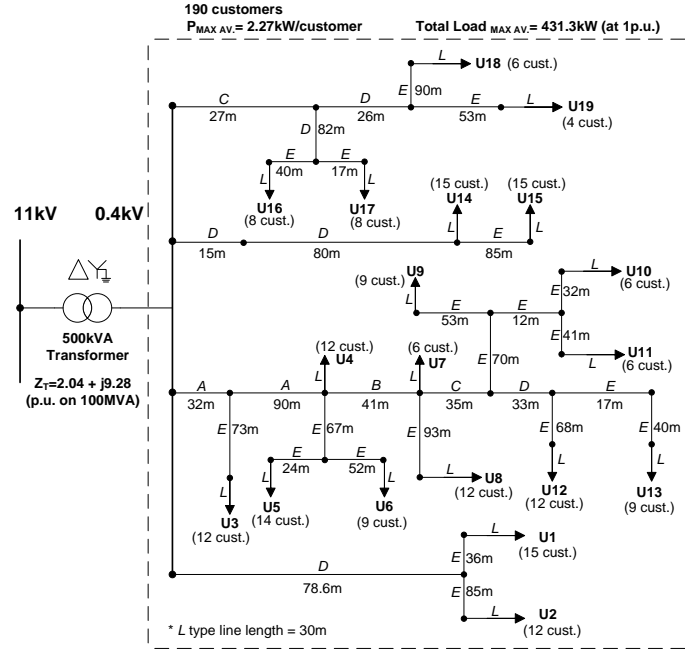

Fig. 4. Underground LV urban distribution network

This analysis considers the reliability equivalent model for urban LV networks presented in Table 5, providing the equivalent failure rate, $\lambda_{eq} = 2.51$ failures/year, and equivalent repair time, $d_{eq} = 17.5$ hours/year, for the buses where the aggregate LV demand is connected. As a direct comparison of this concept, in those scenarios where the equivalent LV networks are not considered for reliability analysis, the failure rate (λ) and repair time (MTTR) for a single LV bus are directly taken from Table 4, which are only equal to $\lambda = 0.005$ failures/year and $d = 24$ hours/year. The significant difference in the failure rate (λ) (now considering the whole LV systems with λ_{eq}) will considerably affect the total number of load interruptions per year, as the LV parts of the system have a dominant impact on the quality of service seen by end customers.

5.1. Network scenarios for reliability planning assessment

Table 6 provides a general description of the scenarios considered for risk and reliability analysis of the test network from Fig. 3.

Table 6. Description of risk and reliability scenarios

SCENARIO 1: Inherent reliability of network components, modelled with their MTTR values
(no back-up action)
SC-1A: No alternative supply (MTTR values, no SQS Reg.) + Constant peak load
SC-1B: No alternative supply (MTTR values, no SQS Reg.) + Time-varying load profile (TVLP)
SC-1C: No alternative supply (MTTR values, no SQS Reg.) + Equivalent LV network models + TVLP
SCENARIO 2: Impact of SQS and Regulator requirements for TTRS on network performance
(manual back-up action)
SC-2A: Alternative supply (Restoration < SQS Reg.) + MTTR values (No 18h Reg.) + TVLP
SC-2B: Alternative supply (Restoration < SQS Reg. + 18h Reg.) + TVLP
SC-2C: Alternative supply (Restoration < SQS Reg. + 18h Reg.) + Equivalent LV network models + TVLP
SCENARIO 3: Impact of automatic switching in combination with SQS/Regulator requirements for TTRS on network performance
SC-3A: Alternative supply (Automatic Switching < 3min + 18h Reg.) + TVLP
SC-3B: Alternative supply (Automatic Switching < 3min + 18h Reg.) + Equivalent LV network models + TVLP

Scenario 1 does not consider the action of any alternative supply or automatically controlled switches between the trunk feeders of the meshed network (i.e. no SQS requirements). Therefore, the 'inherent' reliability performance of the network is analysed as if it was operating radially with no additional support, so the loads' supply is only restored in network components' repair time (i.e. MTTR values, Table 4). Regarding the frequency of interruptions, there is no propagation (or side effects) of any component's fault to other loads in the general system due to network reconfiguration. As the assessment proceeds from SC-1A to SC-1C, different functionalities are added to the reliability analysis, such as the consideration of a time-varying load profile (TVLP) over the day (SC-1B), or the addition of the equivalent LV network models to expand the BSPs at LV (SC-1C). Scenario SC-1A is considered as the base case to compare any added functionality, modelling system loads as a constant peak demand, i.e. 431.3 kW.

The three cases considered in *Scenario 2* investigate the effect of different backup switching functionalities on network reliability performance. Since automatic reclosing is not applied in an all-underground system (i.e. cable faults are considered to be permanent), the aim of analysis is focused on the automation and reconfiguration capabilities provided by the alternative supply at

both ends of the network. This is enabled by the TCBs and fault-detection mechanisms modelled in the 11 kV cables, which are coordinated to react to any outage in the system and prevent as high number of load interruptions as possible. However, the post-fault system's arrangement might cause congestion (i.e. overloading) in a different part of the network and thus lead to a secondary set of interruptions somewhere else in the system. For each outage event, the best possible backup supply is provided at the 11 kV level from either the underground cable loop arrangement (i.e. reflection centre) or the cable '0' that offers available spare capacity (if any) from the infeeding substation. Accordingly, SC-2A applies the SQS regulation to the network switching/backup functionalities depending on the power interrupted and classes of supply in Table 2. This case considers the 'manual' (i.e. not automatic) switching of alternative supply with the applicable time limits of 3 h, 15 min, etc, while faults interrupting a demand less than 1 MW (SQS requirements) are restored within component's MTTR (Table 4).

SC-2B evaluates the impact of the maximum duration of interruptions requirement (18 h) for domestic customers set by the Regulator (Table 3), assuming the supply restoration depends on the action of crew members sent by the DNO to the specific fault location, as there are no backup functionalities at LV level (i.e. ≤ 1 MW GD). Thus, faults that before were restored within component's MTTR, for components with $MTTR > 18$ h now have a maximum restoration time of 18 hours, by allocating a random outage duration (i.e. LI) taken from a value uniformly distributed between 3 min (i.e. $> SI$ values [30]) and 18 h. This enables the analysis of system's response at the time of protecting customers from extremely long interruptions. Accordingly, SC-2C incorporates the equivalent LV networks to the analysis proposed in SC-2B.

Finally, *Scenario 3* incorporates an automatic switching functionality to the switches between the 11 kV trunk feeders and alternative supply. This is considered as a 'smart grid' case with a very high flexibility and low impact on customer's supply. Interruptions that before were counted as LIs, now are restored within 3 minutes (i.e. SIs [30]), so they no longer contribute to SAIFI index but have a counter effect on network's PQ (i.e. MAIFI index).

6. Risk assessment results

Mean values of the resulting reliability indices for the test network are presented in Table 7, which are the first measure to assess any reliability benefit from the different scenarios.

Table 7. Mean reliability indices from analysed scenarios

Urban MV Network	Scenario 1			Scenario 2			Scenario 3	
	SC-1A	SC-1B	SC-1C	SC-2A	SC-2B	SC-2C	SC-3A	SC-3B
SAIFI (LIs/load point/yr)	0.283	0.201	0.071	0.204	0.204	0.07	0.017	0.061
MAIFI (SIs/load point/yr)	0.305	0.21	0.082	0.213	0.213	0.083	0.393	0.091
SAIDI (h/load point/yr)	35.02	24.35	1.518	1.6	0.643	0.661	0.358	0.647
ENS (MWh/load point/yr)	15.042	6.79	0.598	0.396	0.143	0.1703	0.093	0.168
Avg. No. of LIs (per year)	13.606	9.648	64.752	9.799	9.794	63.714	0.803	55.768
Avg. No. of SIs (per year)	14.634	10.082	75.114	10.223	10.224	75.298	18.879	83.058
Avg. Duration of all LIs (h)	123.54	121.14	21.35	7.83	3.15	9.45	21.4	10.58

In SC-1A (base case), no reconfiguration is implemented in the network, and each fault is assumed to interrupt peak demand at the LV BSPs (i.e. 431.3 kW), resulting in high values in Table 7 for duration-based indices such as SAIDI or ENS. However, as soon as SC-1B incorporates a TVLP into the analysis, there is a considerable reduction in the frequency of LIs (SAIFI) and SIs (MAIFI), which is mainly due to the actual operation of the supplying 33/11 kV substation. If a component in one of the parallel branches trips (e.g. a transformer, circuit breaker, etc.), the loading conditions on the other branch are checked in the model, and if they exceed 100% of the component's rated power, the branch/component is disconnected due to overloading. Thus, if system loads are modelled using a constant peak value (SC-1A), the post-fault overloading conditions will occur more frequently than if the loads are modelled with a TVLP (SC-1B), as only a portion of the loads (or none) will be interrupted for most faults over the day.

This contingency situation is illustrated in Fig. 5. When one of the 33/11 kV transformers fails to operate (with rated power of 70%-75% of network's peak load), all demand will still be met by the other transformer as long as it is below its rated capacity (100% MVA), i.e. between 23:00 and 17:00 hours in Fig. 5.

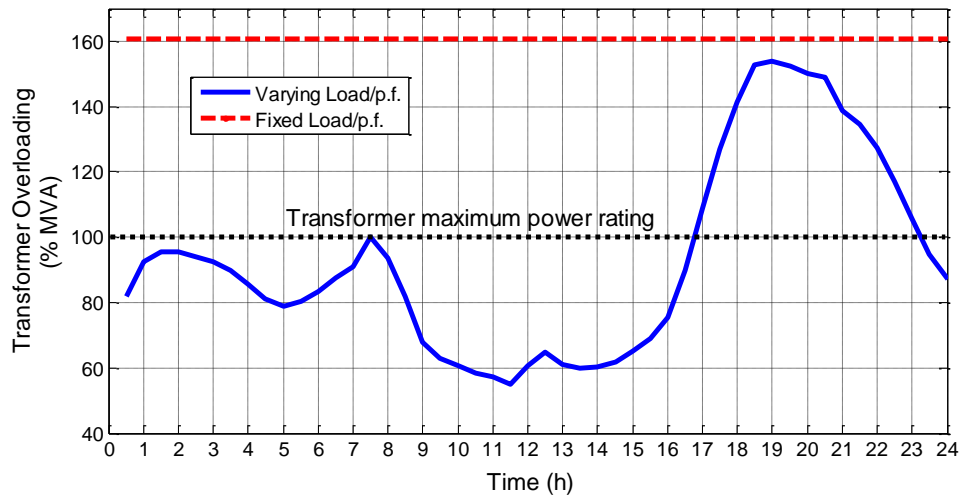

Fig. 5. Overloading of a 33/11 kV transformer during substation contingency

In SC-1C, the equivalent LV networks are included in the analysis, resulting in a higher number of LIs and SIs per year (64.752 and 75.114 respectively, compared with 9.648 and 10.082 in SC-1B) as all components within LV networks are now contributing to the frequency of interruptions in the overall system. This gives an estimation of the number of outages that conventional reliability studies neglect when modelling the network load points as BSPs. With this new scenario (i.e. equivalent LV networks), the rest of average results change according to the new number of served loads (48 LV BSPs x 19 LV PCC = 912 load points), to which all reliability indices are now normalised, but resulting in a more accurate reliability estimation.

Regarding the results from *Scenario 2*, the incorporation of an alternative supply only offers corrective measures affecting the duration, but not the frequency of interruptions. As a result, there is a progressive reduction in duration-based indices (i.e. SAIDI and ENS) due to the implementation of SQS time limits, from SC-2A to SC-2C. Finally, *Scenario 3* confirms the improvement in the number of LIs per year (0.803 (< than 1) and 55.768 respectively), as SAIFI index is almost brought down to zero due to the automatic switching action. Therefore, LIs are now converted into SIs (with the counter effect of higher transient faults, i.e. < 3 min), which make MAIFI index to increase and therefore worsen the PQ of the network. It must be noted that the reduction in SC-3B is not as considerable as in SC-3A. This is due to the fact that the switching functionalities are available in

the MV part of the network only, so they cannot prevent most of the events occurring at LV level, which are considered with the equivalent LV networks in SC-3B.

6.1. Active network stochastic behaviour

Due to the inclusion of new functionalities in the system operation, the network "stochastic behaviour" at MV level is represented in Fig. 6, where the expected average duration of interruptions is provided for the different load points in the urban meshed network of Fig. 3.

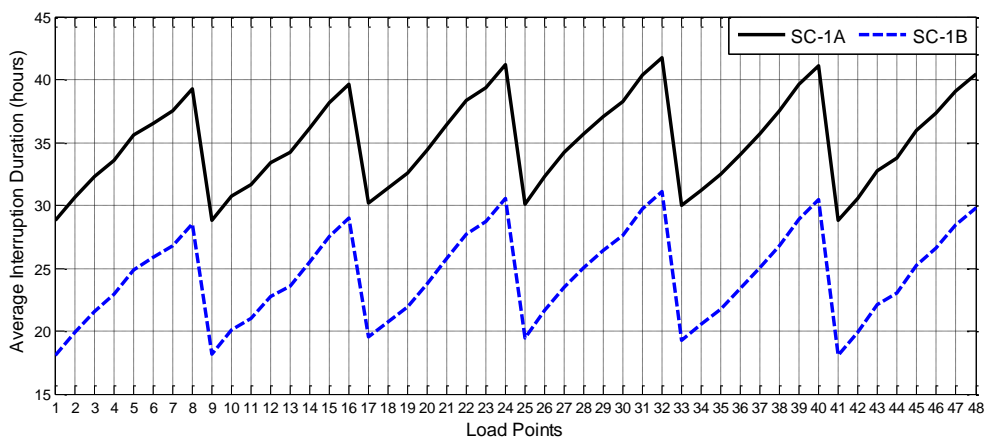

(a) No backup (MTTR values)

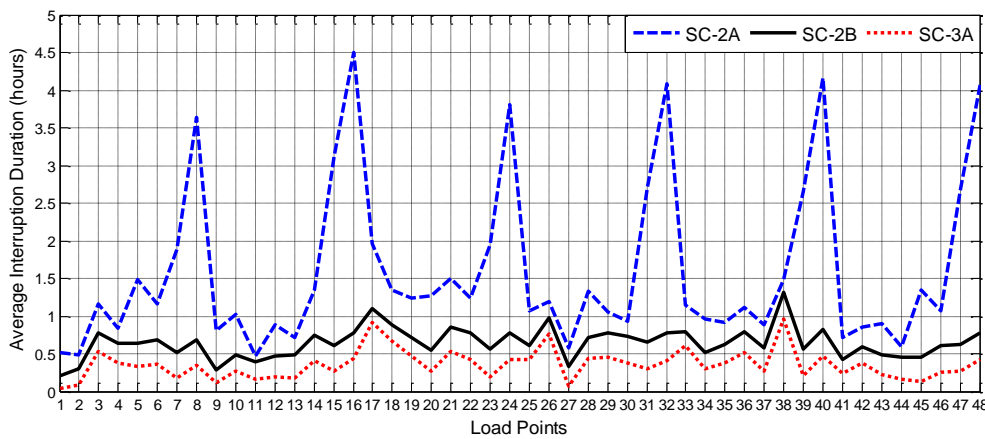

(b) Inclusion of backup functionalities

Fig. 6. Average duration of interruptions per network MV load point

Fig. 6(a) illustrates the MV system's reliability performance as if it was operated radially, i.e. no reconfiguration capabilities. Accordingly, the expected duration of interruptions increases from load points closer to the supplying 33/11 kV substation, to those located further in the 11 kV trunk feeders. The first network functionality that is quantifiable from Fig. 6(a) is the impact of the TVLP

models, which considerably decrease the expected duration of interruptions (from SC-1A to SC-1B) as a consequence of the lower number of LIs. However, the resulting average values are still unrealistic, as no SQS/regulator-imposed requirements are considered yet, i.e. Fig. 6(b). These results emphasise the importance of including the 18-hour threshold to protect customers from extremely long interruptions. In SC-2A, load points located at the end of the 11 kV trunk feeder (i.e. class A, < 1 MW interrupted) are not completely protected from LIs, and therefore their expected outage durations sharply increases in comparison with the rest of load points. As soon as all reconfiguration and automatic switching functionalities are modelled in the simulation (i.e. SC-2B and SC-3A), a considerable reduction is obtained for all load points. Accordingly, the impact of each action can be quantified with respect to the others, which can potentially be used by DNOs for decision-making processes. However, system faults within LV levels are still neglected if LV network equivalents are not considered in the simulation.

6.2. Frequency of interruptions analysis

The calculated PDFs of the frequency-based reliability indices (i.e. SAIFI for LIs and MAIFI for SIs) are provided in Fig. 7 and Fig. 8 respectively.

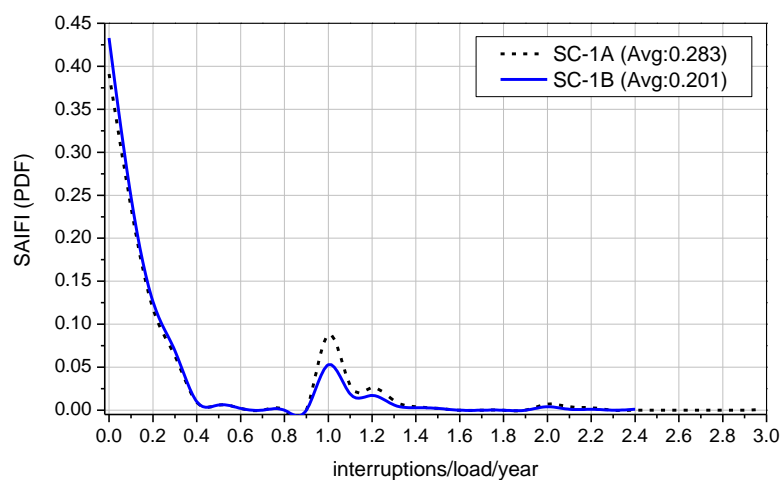

(a) No backup (MTTR values)

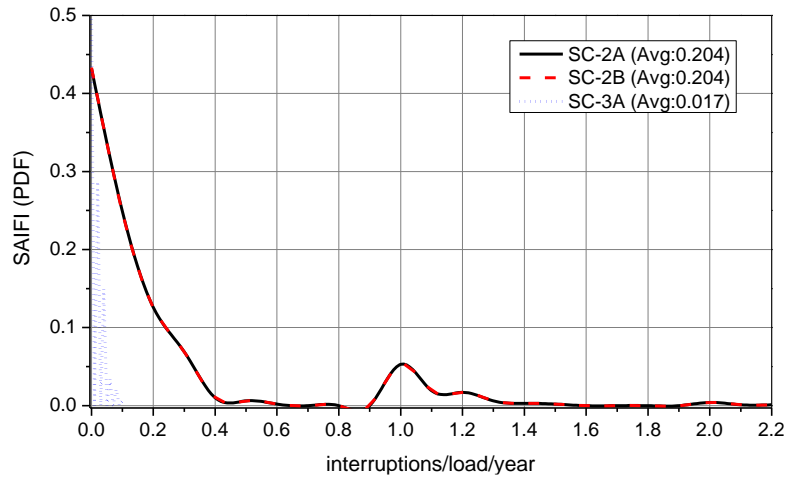

(b) Inclusion of backup functionalities

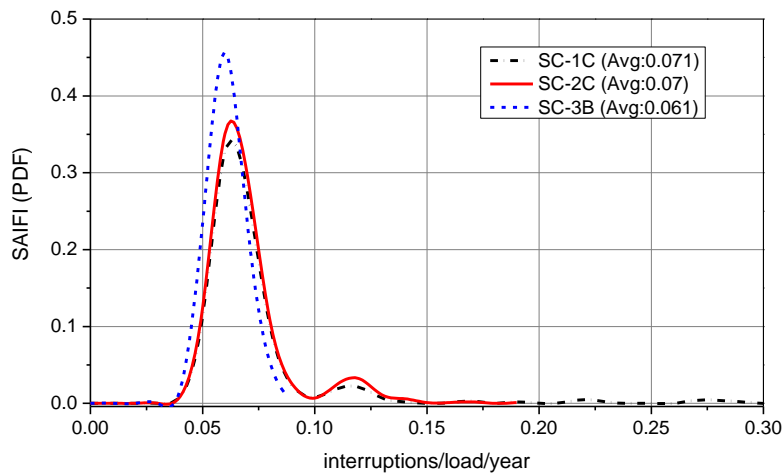

(c) Inclusion of LV network equivalents

Fig. 7. Distribution of SAIIFI index for all network scenarios

Apart from the impact of the TVLP on the frequency of interruptions (SC-1B), no change is experienced in the number of interruptions when SQS/Regulator-imposed requirements are included in the simulation (SC-2A and SC-2B), as these scenarios mostly affect the duration of interruptions only. For these cases, the PDFs show a sudden increase in the values around 1 interruption/load point/year, which corresponds to network faults affecting the total number of load points in the system, e.g. faults taking place in the supplying 33/11 kV substation. As reliability indices are calculated based on the total number of supplied loads, when all of them are interrupted, SAIIFI and MAIFI indices are computed as 1 interruption/load point/year, therefore contributing to the probability of faults around that value. Another network characteristic to highlight is the one offered

by SC-3A, which shifts the resulting SAIFI distribution to values in the vicinity of zero (Fig. 7(b)), but increases the probability of MAIFI index in Fig. 8(b). Again, this effect is due to the ‘smart grid’ automatic switching, avoiding the occurrence of the majority of LI events and turning them into transient faults (SIs), which obviously will have a strong impact on network’s PQ.

In contrast, a different distribution is obtained for SAIFI and MAIFI indicators in Fig. 7(c) and Fig. 8(c), as faults within LV networks have a major contribution to the overall system reliability. The resulting PDFs drastically reduce the dispersion of results around the mean value, providing a more realistic estimation (i.e. the closest match) of the actual number of interruptions taking place in this type of urban networks. With the inclusion of equivalent LV networks in MCS, the number of faults considered in the simulation increases, but so does the number of served loads for the computation of final reliability indices. Also, the probability of SAIFI and MAIFI indices is reduced and increased respectively when SC-3B (‘smart grid’ automatic switching) is assessed, affecting the final number of LIs and SIs.

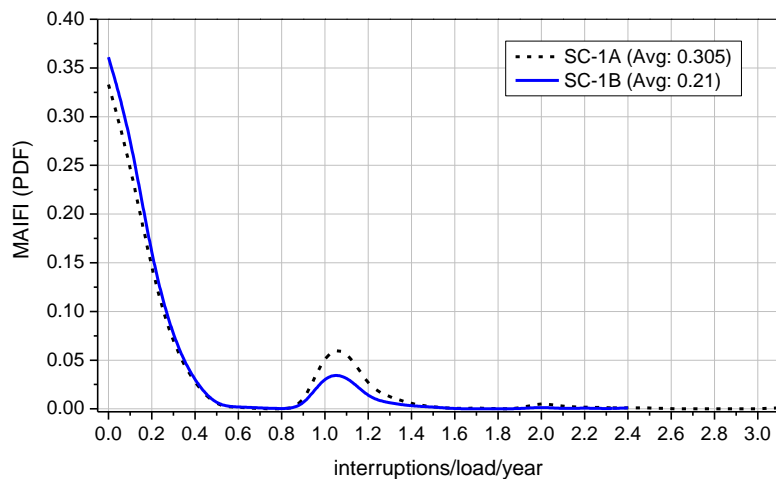

(a) No backup (MTTR values)

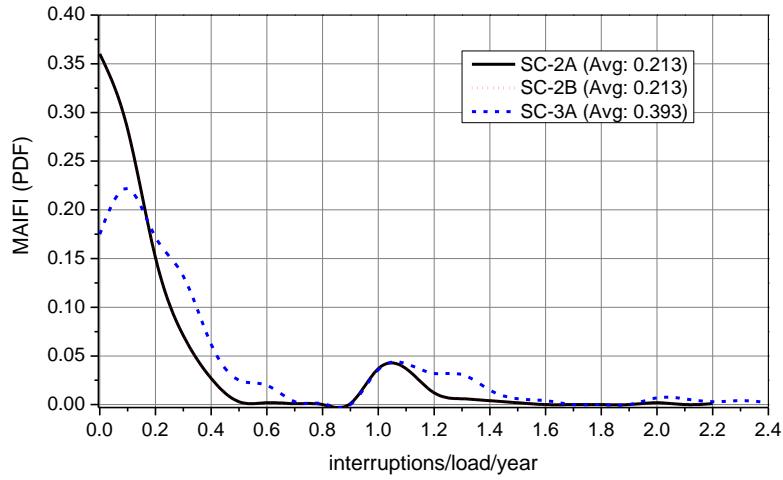

(b) Inclusion of backup functionalities

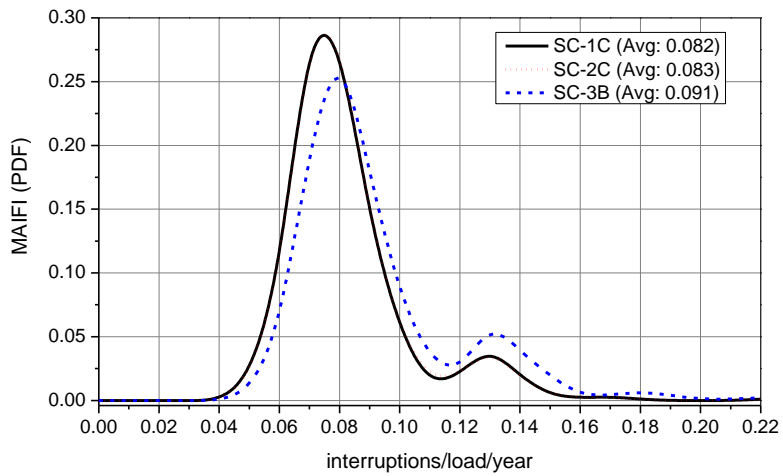

(c) Inclusion of LV network equivalents

Fig. 8. Distribution of MAIFI index for all network scenarios

6.3. Duration of interruptions analysis

The duration-based PDFs obtained for SAIDI index are presented in Fig. 9. In this case, the duration of interruptions is a common factor for every type of network (i.e. from radial to meshed systems, according to the generalised SQS/Regulator requirements), and thus can be directly compared with DNOs' reported values (Table 1). This validation can be used for network planning purposes in order to estimate the risk probability (%) that falls outside the reported thresholds and thus identify parts of DNOs' networks in need of reinforcement.

As shown in Fig. 9, the first scenarios (SC-1A and SC-1B) provide unrealistic values for the outage durations as no backup supply is considered in the simulation. As soon as SQS/Regulator

time thresholds are included in the model, the resulting PDFs (SC-2A and SC-2B) start to provide SAIDI values closer to the stipulated values. Moreover, SC-3A (automatic switching) provides a considerable reduction in the durations' probability, which is only applicable to benefits at the MV level of the system, as load points are still modelled as BSPs and no faults are considered within LV networks.

This effect is shown in Fig. 9(c), which provides more accurate results by considering the longer fault durations within LV networks, due to the fact that no backup actions can be taken to restore the supply (i.e. Class A demand). The higher faults contribution (with their corresponding durations for SAIDI) makes the resulting PDFs to concentrate over a clear mean value, providing less dispersion of results and emphasising the benefits from the use of LV reliability equivalents. Overall, scenarios SC-2C and SC-3B provide a more realistic solution for an accurate planning of system reliability (against DNOs' reported figures), as they consider all possible network functionalities, and now the results offered by the automatic switching are not overestimated as it was the case with SC-3A.

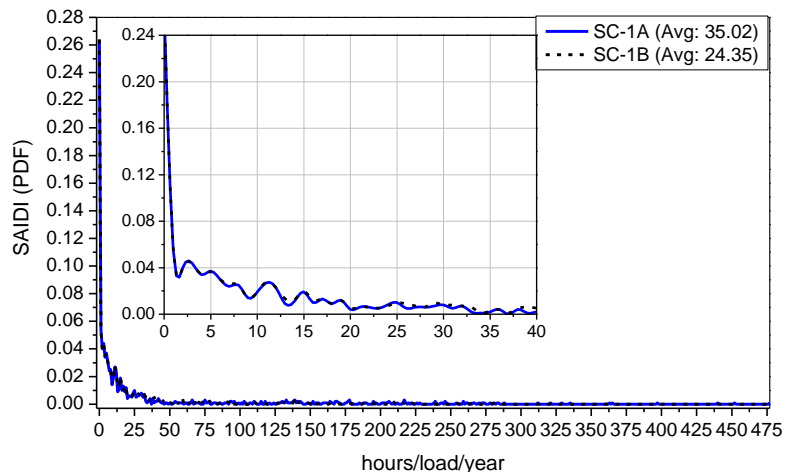

(a) No backup (MTTR values)

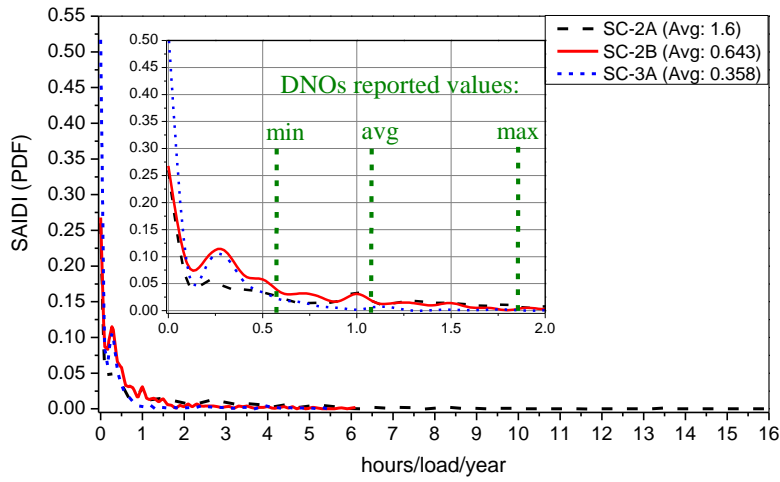

(b) Inclusion of backup functionalities

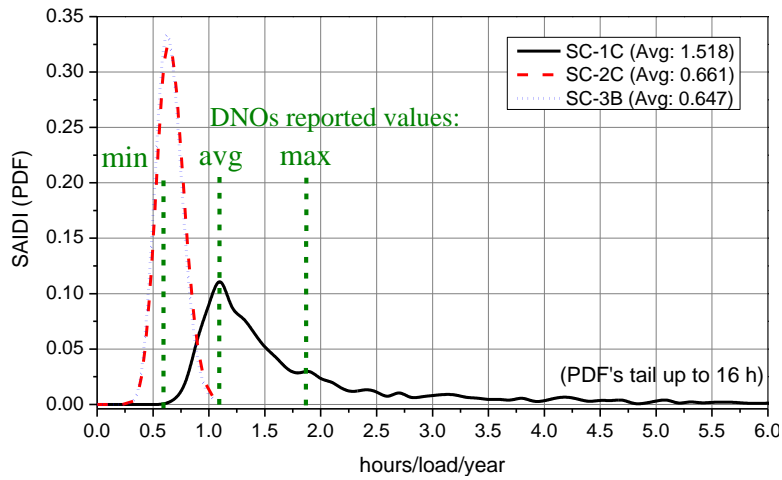

(c) Inclusion of LV network equivalents

Fig. 9. Distribution of SAIDI index for all network scenarios

6.4. Risk assessment of load interruption times

All network restoring functionalities can be more easily quantified with the actual durations of interruptions obtained from MCS, which will avoid masking the results by normalising over the total number of served loads. Therefore, the impact of the different scenarios on network outages is illustrated in Fig. 10.

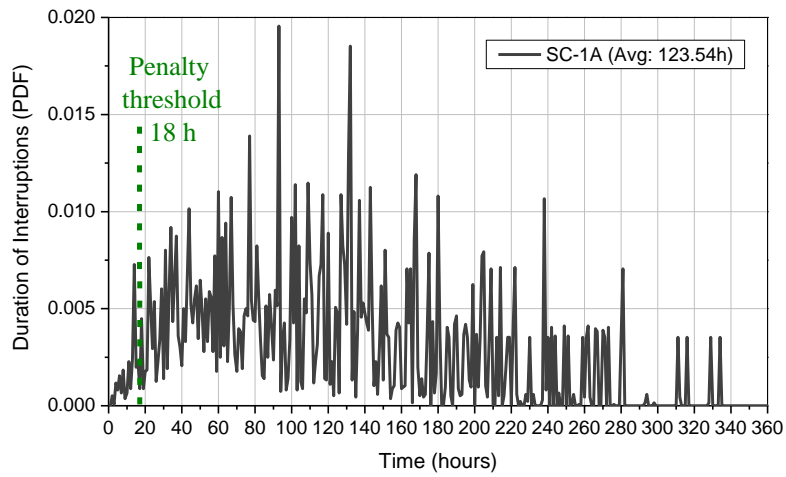

(a) No backup (MTTR values)

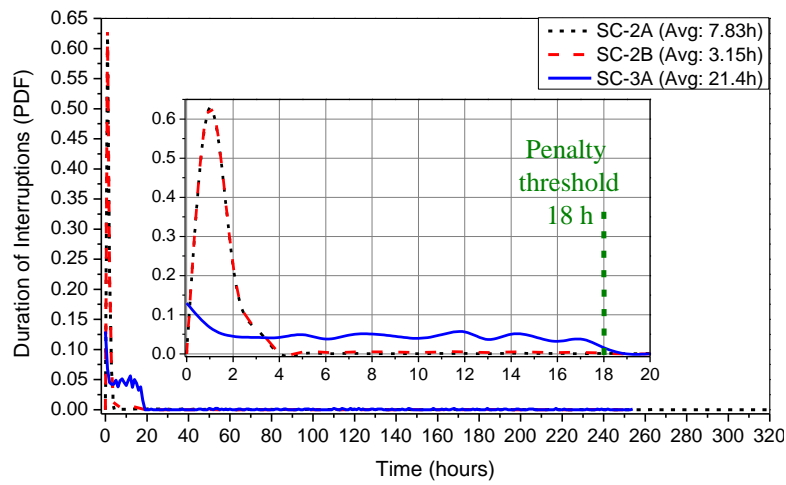

(b) Inclusion of backup functionalities

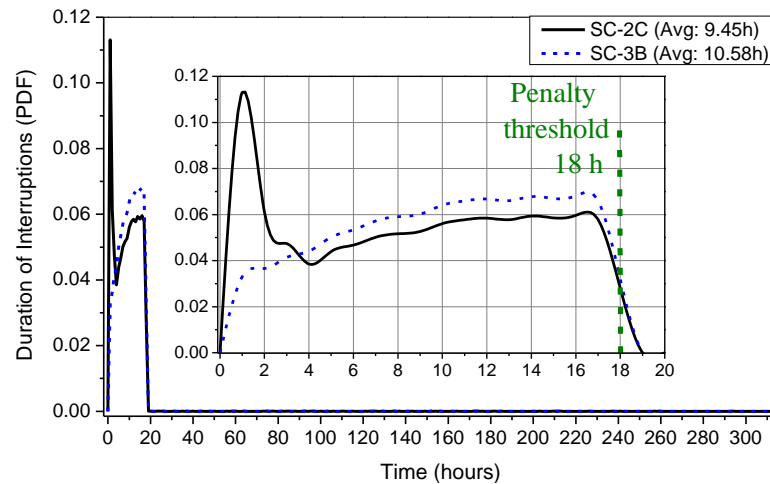

(c) Inclusion of LV network equivalents

Fig. 10. Impact of network functionalities on load interruption times

As a base case, Fig. 10(a) presents the raw probability for the duration of interruptions in the urban network, as no backup action is implemented in the MCS model. This illustrates the 'natural' behaviour of network components reacting to actual MTTR values and thus resulting in very long

interruptions. On the other hand, the impact of SQS restoration on network's MV level (i.e. the one directly connected to the backup supply and reconfiguration switches) is presented in Fig. 10(b), where load points are only modelled as BSPs. The probability for the duration of interruptions is now modified according to SQS requirements. In the urban network of Fig. 3, most components at MV belong to the SQS 'class demand' B (i.e. interrupting GDs between 1 MW and 12 MW), so the supply in those cases must be restored within 3 hours. This backup effect is shown by SC-2A and SC-2B, presenting an accumulated probability within 3 hours, where the curve's tail of the former PDF (SC-2A) is much longer (affecting the average duration) as the penalty threshold of 18 hours (SC-2B) is still not implemented in the network model. Moreover, the automatic switching introduced by SC-3A drastically eliminates the peak probability of LIs (< 3 h) as now those interruptions are restored in less than 3 minutes, so they are not counted as LIs anymore. Thus, the resulting PDF of SC-3A only considers the probability of a reduced number of LIs in the network.

Finally, Fig. 10(c) emphasises the need of including the equivalent LV networks in the model, so all the interruptions taking place in the network (also at LV level) are considered for a more accurate reliability estimation of network performance. In this case, the resulting PDFs show the high percentage/contribution of faults occurring within LV networks (GD class A, < 1 MW), which are usually neglected by conventional MCS procedures. These final results (Fig. 10(c)) were validated against the actual probability data for unplanned outages in networks operated by a UK DNO [31], which showed a high correlation on network's real response to different SQS and switching/restoration actions.

7. Concluding remarks

This paper presents an integrated approach for reliability planning and risk estimation in active distribution systems. Based on generic network models for different load subsectors, a general methodology is developed for reducing system complexity by calculating reliability equivalent models of LV and MV distribution networks. These reliability equivalents, based on the

aggregation of individual power components, avoid the underestimation of system's performance at BSPs, which clearly demonstrates that methods currently used for network reliability assessment should be adapted for an appropriate estimation of the upcoming 'smart grid' functionalities.

Accordingly, conventional reliability assessment procedures are extended in this paper to include actual load profiles, empirical fault probability distributions, as well as UK SQS legislation imposing times to restore supply for interrupted customers. The accuracy and applicability of the proposed methodology is validated through different network scenarios, and expressed by system-related reliability indices.

Regarding the essential considerations for the planning of distribution system's reliability, the analysis is focused on the expected changes in this type of active networks and on the new challenges they introduce to quality of supply studies. Therefore, the stochastic behaviour of the urban test network is assessed by applying different reconfiguration and switching schemes available to DNOs. The proposed methodology allows estimating the risk of interruption times above the Regulator-imposed limits when system's reliability performance is tested to respond to those targets.

8. Acknowledgements

This work was supported by the UK Engineering and Physical Sciences Research Council (EPSRC) project EP/G052530/1.

9. References

- [1] OFGEM, UK Guaranteed Standards: 'Guidance and proposals on best practice - electricity distribution', 2006
- [2] OFGEM, UK Annual Report: 'Electricity distribution quality of service report', 2009
- [3] Council of European Energy Regulators: 'The 4th benchmarking report on quality of electricity supply', 2008
- [4] IEEE 1366: 'IEEE guide for electric power distribution reliability indices', 2012

- [5] ‘Interruption Incentive Scheme (Quality of Service Incentives – Ofgem)’, <https://www.ofgem.gov.uk/electricity/distribution-networks/network-price-controls/quality-service/quality-service-incentives>, accessed February 2015
- [6] ‘Quality of Service Guaranteed Standards – Ofgem’, <https://www.ofgem.gov.uk/licences-codes-and-standards/standards/quality-service-guaranteed-standards>, accessed February 2015
- [7] ‘The electricity standard of performance regulations – Ofgem Statutory Instruments 698, 2010’, <http://www.legislation.gov.uk/>, accessed February 2015
- [8] RIGS, UK Tech. Rep.: ‘Quality of service regulatory instructions and guidance’, 2005
- [9] Brown, R. E.: ‘Electric power distribution reliability’ (CRC Press, 2002)
- [10] Energy Networks Association (ENA): ‘Engineering recommendations P2/6: Security of supply’, 2005
- [11] Hernando-Gil, I., Hayes, B., Collin, A., Djokic, S.: ‘Distribution network equivalents for reliability analysis. Part 1: Aggregation methodology’, 4th IEEE PES Innovative Smart Grid Technologies (ISGT Europe), Copenhagen, Denmark, 2013, pp. 1–5
- [12] Billinton, R., Wang, P.: ‘Reliability-network-equivalent approach to distribution-system-reliability evaluation’, IEE Gener. Transm. Distrib., 1998, vol. 145, no. 2, pp. 149–153
- [13] Hernando-Gil, I., Hayes, B., Collin, A., Djokic, S.: ‘Distribution network equivalents for reliability analysis. Part 2: Storage and demand-side resources’, 4th IEEE PES Innovative Smart Grid Technologies (ISGT Europe), Copenhagen, Denmark, 2013, pp. 1–5
- [14] Energy Networks Association (ENA): ‘National fault and interruption reporting scheme – national system and equipment performance’, 2010
- [15] Ilie, I.-S., Hernando-Gil, I., Djokic, S. Z.: ‘Theoretical interruption model for reliability assessment of power supply systems’, IET Gener. Transm. Distrib., 2013, vol. 8, no. 4, pp. 670–681

- [16] Hernando-Gil, I., Ilie, I.-S., Djokic, S.: ‘Reliability performance of smart grids with demand-side management and distributed generation/storage technologies’, 3rd IEEE PES Innovative Smart Grid Technologies (ISGT Europe), Berlin, Germany, 2012, pp. 1–8
- [17] Ilie, I.-S., Hernando-Gil, I., Djokic, S.: ‘Reliability equivalents of LV and MV distribution networks’, IEEE Energy Conf. (Energycon), Florence, Italy, 2012, pp. 343–348
- [18] Billinton, R., Allan, R. N.: ‘Reliability evaluation of power systems’ (Plenum Press, 1996)
- [19] Billinton, R., Li, W.: ‘Reliability assessment of electrical power systems using Monte Carlo methods’ (Springer, 1994)
- [20] Rubinstein, R. Y., Kroese, D. P.: ‘Simulation and the Monte Carlo method’ (John Wiley & Sons, 2011)
- [21] Billinton, R., Wang, P.: ‘Teaching distribution system reliability evaluation using Monte Carlo simulation’, IEEE Trans. Power Syst., 1999, vol. 14, no. 2, pp. 397–403
- [22] Sankarkrishnan, A., Billinton, R.: ‘Sequential Monte Carlo simulation for composite power system reliability analysis with time varying loads’, IEEE Trans. Power Syst., 1995, vol. 10, no. 3, pp. 1540–1545
- [23] Bhuiyan, M. R., Allan, R.: ‘Modelling multistate problems in sequential simulation of power system reliability studies’, IEE Gener. Transm. Distrib., 1995, vol. 142, no. 4, pp. 343–349
- [24] Ilie, I.-S., Hernando-Gil, I., Djokic, S. Z.: ‘Risk assessment of interruption times affecting domestic and non-domestic electricity customers’, Int. J. Electr. Power Energy Syst., 2014, vol. 55, pp. 59–65
- [25] Hadjsaid, N., Sabonnadière, J. C.: ‘Electrical distribution networks’ (Technology & Engineering ed., John Wiley & Sons, 2013)
- [26] Montgomery, D. C., Runger, G. C.: ‘Applied statistics and probability for engineers’ (John Wiley & Sons, 2010)
- [27] Siemens Energy, ‘Power System Simulator for Engineering’, <http://www.ptius.com/pti/software/psse/index.cfm>, accessed 2012

- [28] Collin, A., Hernando-Gil, I., Acosta, J., Djokic, S.: ‘An 11 kV steady state residential aggregate load model. Part 1: Aggregation methodology’, IEEE PowerTech conf., Trondheim, Norway, 2011, pp. 1–8
- [29] Toledano, S. Y.: ‘Techniques and processes in medium and low voltage electrical installations’ (Editorial Paraninfo, 2007, in Spanish)
- [30] EN50160: ‘Voltage characteristics of electricity supplied by public electricity networks’, 2010
- [31] SP Distribution and SP Manweb, Tech. Rep., ‘Distribution long term development statement for the year 2011/12 to 2015/16’, 2011