



Citation for published version:

Margetts, R & Ngwompo, RF 2015, 'Mode switching in causally dynamic hybrid bond graphs', *Mechatronics*, vol. 28, 1725, pp. 96-102. <https://doi.org/10.1016/j.mechatronics.2015.04.013>

DOI:

[10.1016/j.mechatronics.2015.04.013](https://doi.org/10.1016/j.mechatronics.2015.04.013)

Publication date:

2015

Document Version

Peer reviewed version

[Link to publication](#)

University of Bath

General rights

Copyright and moral rights for the publications made accessible in the public portal are retained by the authors and/or other copyright owners and it is a condition of accessing publications that users recognise and abide by the legal requirements associated with these rights.

Take down policy

If you believe that this document breaches copyright please contact us providing details, and we will remove access to the work immediately and investigate your claim.

Mode Switching in Causally Dynamic Hybrid Bond Graphs

R. Margetts^{* 1} and **R. F. Ngwompo**²

¹School of Engineering, University of Lincoln, Brayford Pool, Lincoln LN6 7TS, UK

²Department of Mechanical Engineering, University of Bath, Claverton Down, Bath BA2 7AY, UK.

Abstract: The Causally Dynamic Hybrid Bond Graph is extended to the case of mode-switching behaviour. Mode-switching ‘trees’ of switches and elements are historically used by bond graph practitioners to represent elements with piecewise-continuous functions. This case is defined as ‘parametric switching’ for the purposes of the hybrid bond graph, since the switching is internal to the element, as opposed to ‘structural switching’ which alters the model structure. This mode-switching ‘tree’ is concatenated into a new controlled element which features Boolean switching parameters in the constitutive equation, removing unnecessary complexity from the model. Mixed-Boolean state equations can be derived from the model, which are nonlinear and/or time-varying (and hence not in the familiar Linear Time Invariant Form). It can be seen that controlled elements often have a static causality assignment and leave the model structure unchanged. The result is a concise method for representing nonlinear behaviour as a piecewise-continuous function in the bond graph modelling framework.

Keywords: Physical System Models, Hybrid Bond Graph, Switched Bond Graph, Mode-switching, Parametric switching.

1. INTRODUCTION

This paper[†] is a continuation of the method for construction and analysis of causally dynamic hybrid bond graphs proposed by the authors [2]. The previous paper suggests the terms ‘structural discontinuities’ and ‘parametric discontinuities’ for classifying discontinuous

* Corresponding author. Tel.: +44 1522 837951. E-mail address: rmargetts@lincoln.ac.uk (R. Margetts).

[†] This paper appears in a preliminary form in the thesis 1. Margetts R. Modelling and Analysis of Hybrid Dynamic Systems using a Bond Graph Approach. University of Bath, 2013.

behaviour in engineering systems, and established controlled junctions for modelling structural discontinuities. In addition, a dynamic sequential causality assignment procedure (DSCAP) was described, yielding mixed-Boolean state equations. This paper completes the method by looking at parametric discontinuities.

The significant body of work on switched and hybrid bond graphs has already been summarised by the authors [1 2], and references numerous proposals such as the use of petri-nets to select continuous bond graph models [3] and various controlled/switching elements. The authors argue that existing methods are best suited to either qualitative analysis or simulation, but rarely both: the causally dynamic controlled junction offers a method which reflects the physics of the system, allows graphical inspection and can generate mixed-Boolean equations for simulation.

Parametric discontinuities are the case where an element ‘switches’ between different constitutive equations. This typically occurs in as *mode-switching systems* where an element’s behaviour changes so rapidly with time (an order of magnitude faster than the overall time-scale [4]) that it can be considered as an instantaneous transition between continuous modes. The system could be modelled as a purely continuous system and solved using a specialist stiff solver, but this approach still gives slow simulation times and is not feasible for real-time applications such as HiL testing. Mode-switching systems include ‘hard nonlinearities,’ where there are distinct modes of operation (e.g. stiction / friction). Alternatively, they can occur where some relationship (gained via empirical data or a high-order function) is best described using a piecewise continuous function, such as tyre stiffness.

Just as a structural discontinuity is expected to manifest in the model structure and affect structural properties of the system, a parametric discontinuity is not. As the behaviour of an element changes with time, there is no structural change to the physical system: nothing is connected or disconnected. Therefore, a physical element with discontinuously changing behaviour should be represented by a modelling element with internalised switching.

Mode switching is usually modelled as a collection of continuous modes of operation, controlled by an automaton, petri-net or similar. Within the bond graph framework, mode switching is typically modelled by a ‘tree’ of ideal switches and standard elements with continuous constitutive equations. Each element gives the equation for a specific mode of

operation, and the ideal switches (de)activate it as required. Naturally, only one ideal switch can be ON at any time during a simulation. Soderman [5] and Strömberg [6] formulate mode switching ‘trees’ of switched sources, and Mosterman and Biswas [4] present a multi-bond controlled junction selecting a continuous bond graph element from a number of possibilities.

Mode switching has a conceptual advantage in that it aids the development of finite state automata for simulation. However, the ‘tree’ notation means a model can rapidly grow to a vast size with multiple inputs and outputs for all possible modes of operation. This makes it unsuitable for structural analysis and equation generation purposes. The multi-bond notation suggested by Mosterman and Biswas goes some way to controlling this, but is a little confusing because multibond notation is typically used for multiple degrees of freedom in a model. Their idea is used as a basis for the controlled element defined here.

Hence, a mode-switching tree is used to define a *controlled element* with a mixed-Boolean constitutive equation. This simplifies structural analysis of the bond graph and associated mathematical model, whilst retaining the rigor of the ‘tree’ notation.

2. THE CONTROLLED ELEMENT FOR PARAMETRIC DISCONTINUITIES

This section proposes a new *controlled element* for the modelling of parametric switching. They should not be confused with the existing switched element, which has an on/off behaviour [7].

Consider an element with a piecewise-continuous constitutive function. A mode-switching tree can be constructed using the controlled junctions with associated Boolean terms (as used for structural switching), as shown in Figure 1. Note that a resistance element is shown, but the principle holds true for inertia and compliance elements.

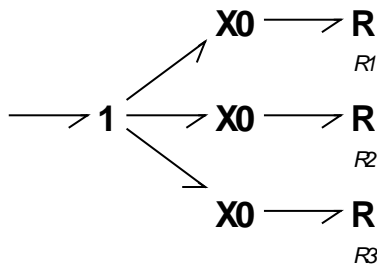

a) A 'Tree' of X0-Junctions

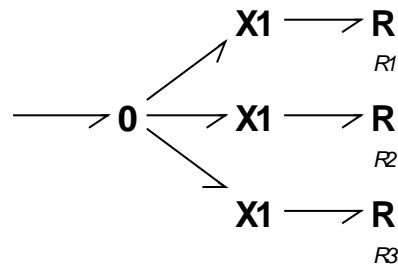

b) A 'Tree' of X1-Junctions

Figure 1: Bond Graph 'Trees' for a Piecewise Linear Resistance Element, Assuming Three Modes of Operation.

In this tree, controlled junctions (de)activate the modes of operation, which are given by resistance elements on each branch. These 'branches' are then connected by a regular junction which sums the output values.

- In Figure 1a) efforts are summed about a 1-junction: these efforts are the effort exerted by the resistance when a junction is ON plus the zero efforts exerted by the X0-junctions when they are OFF.
- In Figure 1b), it is flows which are summed around a zero junction: these flows are the flow exerted by the resistance when a junction is ON plus the zero flows exerted by the X1-junctions when they are OFF.

In a bond graph tree it is important to note that the controlled junctions are constrained so that only one may be ON at any time.

In order to condense the 'tree' into a single controlled element, consider the underlying equations. Quantities are shown on the causal bond graph in Figure 2. The Boolean parameters associated with the controlled junctions are denoted μ . A reference configuration of $\mu_1 = 1, \mu_2 = 0, \mu_3 = 0$ is arbitrarily assumed. Note that dynamic causality is internal to the tree: there is static causality on the resistance elements and the input bond.

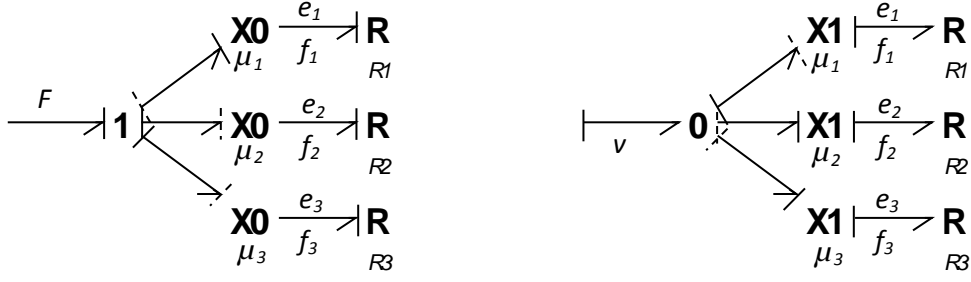

Figure 2: The Piecewise Linear Resistance Element Subsystem, showing quantities used in Equation Generation.

The Junction Structure Matrices are (for force input and velocity input respectively):

$$\begin{bmatrix} \mu_1 & 0 & 0 \\ 0 & \mu_2 & 0 \\ 0 & 0 & \mu_3 \end{bmatrix} \begin{bmatrix} e_1 \\ e_2 \\ e_3 \end{bmatrix} = \begin{bmatrix} 0 & 0 & 0 & \mu_1 \\ 0 & 0 & 0 & \mu_2 \\ 0 & 0 & 0 & \mu_3 \end{bmatrix} \begin{bmatrix} f_1 \\ f_2 \\ f_3 \\ F \end{bmatrix}, \quad \begin{bmatrix} \mu_1 & 0 & 0 \\ 0 & \mu_2 & 0 \\ 0 & 0 & \mu_3 \end{bmatrix} \begin{bmatrix} f_1 \\ f_2 \\ f_3 \end{bmatrix} = \begin{bmatrix} 0 & 0 & 0 & \mu_1 \\ 0 & 0 & 0 & \mu_2 \\ 0 & 0 & 0 & \mu_3 \end{bmatrix} \begin{bmatrix} e_1 \\ e_2 \\ e_3 \\ v \end{bmatrix}$$

And the Field Laws $D_{in} = LD_{out}$ are:

$$\begin{bmatrix} e_1 & 0 & 0 \\ 0 & e_2 & 0 \\ 0 & 0 & e_3 \end{bmatrix} = \begin{bmatrix} \mu_1 R_1 & 0 & 0 \\ 0 & \mu_2 R_2 & 0 \\ 0 & 0 & \mu_3 R_3 \end{bmatrix} \begin{bmatrix} f_1 \\ f_2 \\ f_3 \end{bmatrix}, \quad \begin{bmatrix} f_1 & 0 & 0 \\ 0 & f_2 & 0 \\ 0 & 0 & f_3 \end{bmatrix} = \begin{bmatrix} \mu_1 R_1^{-1} & 0 & 0 \\ 0 & \mu_2 R_2^{-1} & 0 \\ 0 & 0 & \mu_3 R_3^{-1} \end{bmatrix} \begin{bmatrix} e_1 \\ e_2 \\ e_3 \end{bmatrix}$$

Looking at the summation, we can write:

$$f = f_1 + f_2 + f_3$$

$$f = \mu_1 R_1^{-1} e_1 + \mu_2 R_2^{-1} e_2 + \mu_3 R_3^{-1} e_3$$

$$e = e_1 + e_2 + e_3$$

$$e = \mu_1 R_1 f_1 + \mu_2 R_2 f_2 + \mu_3 R_3 f_3$$

And, since flow is constant,

$$f = (\mu_1 R_1^{-1} + \mu_2 R_2^{-1} + \mu_3 R_3^{-1}) F$$

And, since effort is constant,

$$e = (\mu_1 R_1 + \mu_2 R_2 + \mu_3 R_3) v$$

This principle will hold true for ‘trees’ of compliance and inertia elements. A general definition for the controlled element can therefore be defined as shown in Table 1.

Proposition 1: A Controlled Element for Parametric Switching

A mode-switching tree of controlled junctions and elements can be condensed into a single controlled element. This controlled element has the general constitutive function:

$$output = \sum_{n=1}^i \mu_n \Phi_n(input) \quad (1)$$

Where n is the number of branches to the tree, μ_n is the Boolean term associated with n th controlled junction and Φ_n is the constitutive function of the n th element.

Table 1: Controlled Elements and their Constitutive Equations (Causally Static, Linear Case)

$\text{---} \nearrow \mathbf{XR}$ or $\text{---} \dashv \mathbf{XR}$	$f = \left(\sum \mu R^{-1}\right) e$ or $e = \left(\sum \mu R\right) f$
$\text{---} \dashv \mathbf{XC}$	$e = \left(\sum \mu C^{-1}\right) \int f \cdot dt$
$\text{---} \nearrow \mathbf{XI}$	$f = \left(\sum \mu I^{-1}\right) \int e \cdot dt$

The controlled element may be in dynamic causality (i.e. the output is effort in some modes and flow in others) it can be treated in the same way as a standard element in dynamic causality i.e. having two input/output pairs for the two causal assignments. In practise this rarely happens.

Table 2 overviews the possible controlled elements, defining them as elements with a Heaviside function as their constituent equations (which can be controlled either internally or by an external modulation signal).

3. EQUATION GENERATION FROM THE CAUSALLY DYNAMIC HYBRID BOND GRAPH

3.1. The General Hybrid Bond Graph

Recall that a causal bond graph model can be represented in matrix format, as a Junction Structure Matrix (JSM) consisting of ones and zeros which relate the system inputs and outputs.

A modified ‘hybrid’ version has been defined to capture structural switching behaviour and the induced dynamic causality. In addition to 1’s and 0’s, this JSM also consists of Boolean parameters λ indicating the state of controlled junctions describing structural discontinuities. Figure 3 shows the bond graph junction structure diagrammatically and the key variables used in equation generation. Input vectors are the state vector $\dot{\mathbf{X}}_i$ (composed of \dot{p} and \dot{q} on I and C elements in integral causality), the complement of the pseudo-state vector \mathbf{Z}_d (composed of f and e on I and C elements in derivative causality) the output from the resistance field \mathbf{D}_{out} (composed of effort or flow variables into dissipative elements) and system inputs \mathbf{U} . Output vectors are the complement of the state vector \mathbf{Z}_i , the pseudo-state vector $\dot{\mathbf{X}}_d$ and the input to the resistance field \mathbf{D}_{in} . Where there is structural switching in the model, these vectors may relate to elements in static or dynamic causality (denoted \sim or \wedge respectively) [2].

For the structural switching case, controlled junctions (dis)connect regions of the model structure and Boolean terms manifest λ in the junction structure matrix. For the parametric switching case, mode-switching is internal to the controlled element(s) and additional Boolean terms μ therefore manifest in the storage and dissipative fields.

Consider the junction structure equation for the General Hybrid Bond Graph. Junction Structure Matrix \mathbf{S} is a function of Boolean terms λ which relate to the state of the controlled junctions in the model. In addition, a matrix of Boolean expressions $\Lambda(\lambda)$ activates or deactivates input variables according to the mode of operation of the model.

Table 2: Proposed Constituent Equations for Controlled Elements (General Case)

$\dashrightarrow \mathbf{XC}$	$e = \begin{vmatrix} \Phi_{C1}^{-1} \left(\int f \cdot dt \right) \\ \vdots \\ \Phi_{Cn}^{-1} \left(\int f \cdot dt \right) \end{vmatrix}$
$\dashrightarrow \mathbf{XI}$	$f = \begin{vmatrix} \Phi_{I1}^{-1} \left(\int e \cdot dt \right) \\ \vdots \\ \Phi_{In}^{-1} \left(\int e \cdot dt \right) \end{vmatrix}$
$\dashrightarrow \mathbf{XR}$ or $\dashrightarrow \mathbf{XR}$	$f = \begin{vmatrix} \Phi_{R1}^{-1}(e) \\ \vdots \\ \Phi_{Rn}^{-1}(e) \end{vmatrix} \quad \text{or} \quad e = \begin{vmatrix} \Phi_{R1}(f) \\ \vdots \\ \Phi_{Rn}(f) \end{vmatrix}$
$\dashrightarrow \mathbf{XC}$	$e = \begin{vmatrix} \Phi_{C1}^{-1} \left(\int f \cdot dt \right) \\ \vdots \\ \Phi_{Cn}^{-1} \left(\int f \cdot dt \right) \end{vmatrix} \quad f = \begin{vmatrix} \Phi_{C1d} \frac{d}{dt}(e) \\ \vdots \\ \Phi_{Cm} \frac{d}{dt}(e) \end{vmatrix}$
$\dashrightarrow \mathbf{XI}$	$f = \begin{vmatrix} \Phi_{I1}^{-1} \left(\int e \cdot dt \right) \\ \vdots \\ \Phi_{In}^{-1} \left(\int e \cdot dt \right) \end{vmatrix} \quad e = \begin{vmatrix} \Phi_{I1i} \frac{d}{dt}(f) \\ \vdots \\ \Phi_{Im} \frac{d}{dt}(f) \end{vmatrix}$
$\dashrightarrow \mathbf{XR}$	$f = \begin{vmatrix} \Phi_{R1}^{-1}(e) \\ \vdots \\ \Phi_{Rn}^{-1}(e) \end{vmatrix} \quad e = \begin{vmatrix} \Phi_{\hat{R}1}(f) \\ \vdots \\ \Phi_{\hat{R}n}(f) \end{vmatrix}$

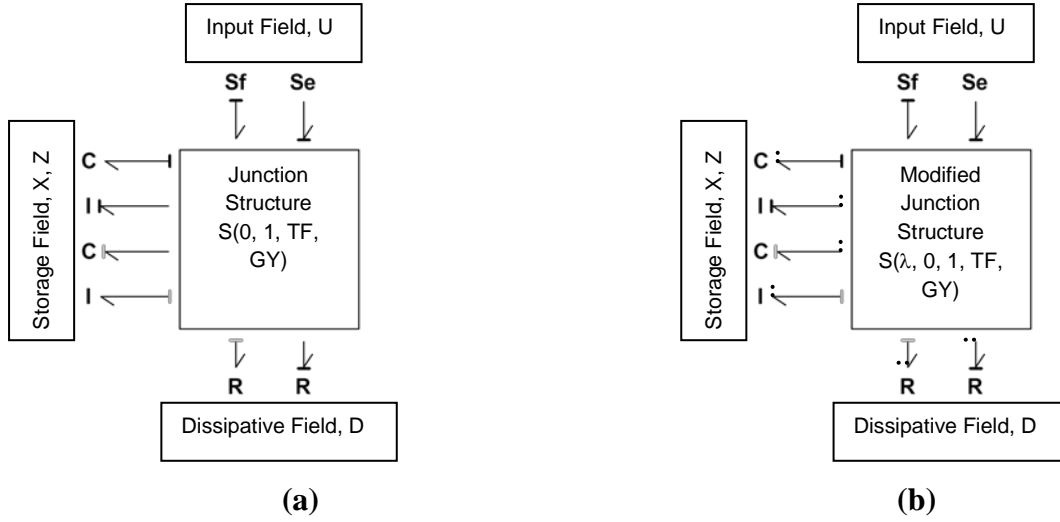

Fig. 3: The Junction Structure Matrix and Generalised Bond Graph.

(a) General Junction Structure; (b) Hybrid Junction Structure incorporating switching (λ) coefficients and dynamic causality

The Junction Structure Matrix is typically used to derive state equations which – for a continuous model with linear elements – usually takes the Linear Time Invariant state space form. For the causally dynamic hybrid bond graph with structural switching, an implicit form was derived. For parametric switching, however, the LTI form is usually invalid. Parametric switching is frequently used to describe highly nonlinear behaviour as piecewise continuous functions. In addition, they may be time varying if commutation is a function of time. Hence a more general state equation must be derived.

The junction structure matrix relates the outputs of the hybrid dynamic junction structure to the inputs by Equation (3) [2], presented here without proof.

$$\begin{bmatrix} \Lambda_{11} & \mathbf{0} & \mathbf{0} \\ \mathbf{0} & \Lambda_{22} & \mathbf{0} \\ \mathbf{0} & \mathbf{0} & \Lambda_{33} \end{bmatrix} \begin{bmatrix} \dot{X}_i \\ Z_d \\ D_{out} \end{bmatrix} = \begin{bmatrix} S_{11} & S_{12} & S_{13} & S_{14} \\ -S_{12}^T & \mathbf{0} & \mathbf{0} & S_{24} \\ -S_{13}^T & \mathbf{0} & S_{33} & S_{34} \end{bmatrix} \begin{bmatrix} Z_i \\ \dot{X}_d \\ D_{in} \\ U \end{bmatrix} \quad (2)$$

The matrices Λ and S_{ij} are functions of the Boolean parameters λ given by the state of all controlled junctions in the model.

To derive the state equations, the established procedure is to eliminate the \mathbf{D}_{in} and \mathbf{D}_{out} terms by rearranging row three and substituting into rows one and two. Looking at row 3 of equation (2):

$$\Lambda_{33}\mathbf{D}_{out} = -\mathbf{S}_{13}^T\mathbf{Z}_i + \mathbf{S}_{33}\mathbf{D}_{in} + \mathbf{S}_{34}\mathbf{U} \quad (3)$$

Where the constitutive equation for the dissipative field is:

$$\mathbf{D}_{in} = \Phi_L(\boldsymbol{\mu}, \mathbf{D}_{out}) \quad (4)$$

Where Φ_L is a matrix of functions relating outputs to inputs. These are potentially nonlinear functions, and – where parametric switching exists – they are mixed-Boolean.

Substituting (4) in (3) and solving for \mathbf{D}_{in} gives:

$$\Lambda_{33}\Phi_L^{-1}(\boldsymbol{\mu}, \mathbf{D}_{in}) - \mathbf{S}_{33}\mathbf{D}_{in} = -\mathbf{S}_{13}^T\mathbf{Z}_i + \mathbf{S}_{34}\mathbf{U} \quad (5)$$

The expression for \mathbf{D}_{in} depends on the nature of function Φ_L . Hence, \mathbf{D}_{in} cannot be simply replaced in this derivation as it could for the LTI case.

However, the complementary states can be eliminated. Taking row one of (2):

$$\Lambda_{11}\dot{\mathbf{X}}_i = \mathbf{S}_{11}\mathbf{Z}_i + \mathbf{S}_{12}\dot{\mathbf{X}}_d + \mathbf{S}_{13}\mathbf{D}_{in} + \mathbf{S}_{14}\mathbf{U} \quad (6)$$

Recall that states are related to their complements by the constituent equations of the storage elements. In the linear case, this matrix is:

$$\begin{bmatrix} \mathbf{Z}_i \\ \mathbf{Z}_d \end{bmatrix} = \begin{bmatrix} F_i & F \\ F^T & F_d \end{bmatrix} \begin{bmatrix} \mathbf{X}_i \\ \mathbf{X}_d \end{bmatrix} \quad (7)$$

In this general case, this relationship is a field of potentially nonlinear, mixed-Boolean functions.

$$\begin{aligned}\mathbf{Z}_i &= \Phi_{Fi}(\boldsymbol{\mu}, \mathbf{X}_i) + \Phi_{Fid}(\boldsymbol{\mu}, \mathbf{X}_d) \\ \mathbf{Z}_d &= \Phi_{Fdi}(\boldsymbol{\mu}, \mathbf{X}_i) + \Phi_{Fd}(\boldsymbol{\mu}, \mathbf{X}_d)\end{aligned}\quad (8)$$

Where the cross-coupling relationships are given the subscripts id and di .

$$\Lambda_{11}\dot{\mathbf{X}}_i = \mathbf{S}_{11}\Phi_{Fi}(\boldsymbol{\mu}, \mathbf{X}_i) + \mathbf{S}_{11}\Phi_{Fid}(\boldsymbol{\mu}, \mathbf{X}_d) + \mathbf{S}_{12}\dot{\mathbf{X}}_d + \mathbf{S}_{13}\mathbf{D}_{in} + \mathbf{S}_{14}\mathbf{U}\quad (9)$$

Likewise, row two of (3) yields:

$$\begin{aligned}\Lambda_{22}\mathbf{Z}_d &= -\mathbf{S}_{12}^T\mathbf{Z}_i + \mathbf{S}_{24}\mathbf{U} \\ \Lambda_{22}\Phi_{Fdi}(\boldsymbol{\mu}, \mathbf{X}_i) + \Lambda_{22}\Phi_{Fd}(\boldsymbol{\mu}, \mathbf{X}_d) &= -\mathbf{S}_{12}^T\Phi_{Fi}(\boldsymbol{\mu}, \mathbf{X}_i) - \mathbf{S}_{12}^T\Phi_{Fid}(\boldsymbol{\mu}, \mathbf{X}_d) + \mathbf{S}_{24}\mathbf{U}\end{aligned}\quad (10)$$

Rearranging gives:

$$0 = \mathbf{S}_{12}^T\Phi_{Fi}(\boldsymbol{\mu}, \mathbf{X}_i) + \Lambda_{22}\Phi_{Fdi}(\boldsymbol{\mu}, \mathbf{X}_i) + \Lambda_{22}\Phi_{Fd}(\boldsymbol{\mu}, \mathbf{X}_d) + \mathbf{S}_{12}^T\Phi_{Fid}(\boldsymbol{\mu}, \mathbf{X}_d) - \mathbf{S}_{24}\mathbf{U}\quad (11)$$

Hence, the system equations are a state equation, an associated algebraic constraint (for cases where storage elements are dynamic causality) and an expression for input to the dissipative field (which can be substituted into the state equation). Acknowledging that the functions can be mixed-Boolean, this can be written concisely as:

$$\begin{aligned}\Lambda_{11}\dot{\mathbf{X}}_i &= \mathbf{S}_{11}\Phi_{Fi}(\mathbf{X}_i) + \mathbf{S}_{11}\Phi_{Fid}(\mathbf{X}_d) + \mathbf{S}_{12}\dot{\mathbf{X}}_d + \mathbf{S}_{13}\mathbf{D}_{in} + \mathbf{S}_{14}\mathbf{U} \\ 0 &= \mathbf{S}_{12}^T\Phi_{Fi}(\mathbf{X}_i) + \Lambda_{22}\Phi_{Fdi}(\mathbf{X}_i) + \Lambda_{22}\Phi_{Fd}(\mathbf{X}_d) + \mathbf{S}_{12}^T\Phi_{Fid}(\mathbf{X}_d) - \mathbf{S}_{24}\mathbf{U} \\ \Lambda_{33}\Phi_L^{-1}(\mathbf{D}_{in}) - \mathbf{S}_{33}\mathbf{D}_{in} &= -\mathbf{S}_{13}^T\Phi_{Fi}(\mathbf{X}_i) - \mathbf{S}_{13}^T\Phi_{Fid}(\mathbf{X}_d) + \mathbf{S}_{34}\mathbf{U}\end{aligned}\quad (12)$$

Regardless of the form that $\Phi_L^{-1}(\mathbf{D}_{in})$ takes, it should be clear that the state equation contains nonlinear functions relating to the dissipative and storage fields, and these functions are mixed-Boolean where parametric switching occurs. The algebraic constraint also contains potentially mixed-Boolean nonlinear functions relating to the storage field.

4. MODEL PROPERTIES

4.1. Properties of the General Model

Assume a model has parametric switching but no structural switching. I.e. it is a function of μ but not λ . Recall Equation (12), which is a function of μ but, in this case, not parameters relating to structural switching λ . Hence $\mathbf{S} \neq f(\lambda)$ and $\mathbf{\Lambda} = \mathbf{I}$:

$$\begin{aligned}\dot{\mathbf{X}}_i &= \mathbf{S}_{11} \Phi_{Fi}(\mathbf{X}_i) + \mathbf{S}_{11} \Phi_{Fid}(\mathbf{X}_d) + \mathbf{S}_{12} \dot{\mathbf{X}}_d + \mathbf{S}_{13} \mathbf{D}_{in} + \mathbf{S}_{14} \mathbf{U} \\ 0 &= \mathbf{S}_{12}^T \Phi_{Fi}(\mathbf{X}_i) + \mathbf{\Lambda} \Phi_{Fdi}(\mathbf{X}_i) + \mathbf{\Lambda}_{22} \Phi_{Fd}(\mathbf{X}_d) + \mathbf{S}_{12}^T \Phi_{Fid}(\mathbf{X}_d) - \mathbf{S}_{24} \mathbf{U} \\ \Phi_L^{-1}(\mathbf{D}_{in}) - \mathbf{S}_{33} \mathbf{D}_{in} &= -\mathbf{S}_{13}^T \Phi_{Fi}(\mathbf{X}_i) - \mathbf{S}_{13}^T \Phi_{Fid}(\mathbf{X}_d) + \mathbf{S}_{34} \mathbf{U}\end{aligned}\quad (13)$$

4.2. Properties of the Linearised Model in one mode

Assume a single mode of operation, in which all constitutive equations are linear or can be linearised. Equation (5) becomes;

$$\begin{aligned}L^{-1} \mathbf{D}_{in} - \mathbf{S}_{33} \mathbf{D}_{in} &= -\mathbf{S}_{13}^T (F_i \mathbf{X}_i + F_{id} \mathbf{X}_d) + \mathbf{S}_{34} \mathbf{U} \\ \mathbf{D}_{in} &= L(I - \mathbf{S}_{33} L)^{-1} (-\mathbf{S}_{13}^T (F_i \mathbf{X}_i + F_{id} \mathbf{X}_d) + \mathbf{S}_{34} \mathbf{U})\end{aligned}\quad (14)$$

And this can be substituted into (12) to give:

$$\begin{aligned}\dot{\mathbf{X}}_i &= \mathbf{S}_{11} F_i \mathbf{X}_i + \mathbf{S}_{11} F_{id} \mathbf{X}_d + \mathbf{S}_{12} \dot{\mathbf{X}}_d + \mathbf{S}_{13} \left[L(I - \mathbf{S}_{33} L)^{-1} (-\mathbf{S}_{13}^T (F_i \mathbf{X}_i + F_{id} \mathbf{X}_d) + \mathbf{S}_{34} \mathbf{U}) \right] + \mathbf{S}_{14} \mathbf{U} \\ \dot{\mathbf{X}}_i - \mathbf{S}_{12} \dot{\mathbf{X}}_d &= (\mathbf{S}_{11} - \mathbf{S}_{13} \mathbf{H} \mathbf{S}_{13}^T) F_i \mathbf{X}_i + (\mathbf{S}_{11} - \mathbf{S}_{13} \mathbf{H} \mathbf{S}_{13}^T) F_{id} \mathbf{X}_d + (\mathbf{S}_{13} \mathbf{H} \mathbf{S}_{34} + \mathbf{S}_{14}) \mathbf{U}\end{aligned}\quad (15)$$

And, likewise:

$$0 = (\mathbf{S}_{12}^T F_i + F_{di}) \mathbf{X}_i + (F_d + \mathbf{S}_{12}^T F_{id}) \mathbf{X}_d - \mathbf{S}_{24} \mathbf{U}\quad (16)$$

Yielding the familiar implicit equation:

$$\begin{bmatrix} I & -\mathbf{S}_{12} \\ 0 & 0 \end{bmatrix} \begin{bmatrix} \dot{\mathbf{X}}_i \\ \dot{\mathbf{X}}_d \end{bmatrix} = \begin{bmatrix} (\mathbf{S}_{11} - \mathbf{S}_{13} \mathbf{H} \mathbf{S}_{13}^T) F_i & (\mathbf{S}_{11} - \mathbf{S}_{13} \mathbf{H} \mathbf{S}_{13}^T) F_{id} \\ (\mathbf{S}_{12}^T F_i + F_{di}) & (F_d + \mathbf{S}_{12}^T F_{id}) \end{bmatrix} \begin{bmatrix} X_i \\ X_d \end{bmatrix} + \begin{bmatrix} (\mathbf{S}_{14} + \mathbf{S}_{13} \mathbf{H} \mathbf{S}_{34}) \\ \mathbf{S}_{24} \end{bmatrix} \mathbf{U}\quad (17)$$

Essentially, the form of the equation remains the same in each mode of operation and the values of the coefficients \mathbf{F} and \mathbf{H} (which is a function of \mathbf{L}) vary as parametric switching coefficients $\boldsymbol{\mu}$ vary. If there is just causally static parametric switching in the model (and no structural switching), the modeller would typically seek to eliminate any [static] derivative causality. In this case, $\dim \dot{\mathbf{X}}_d = 0$ and the explicit state equation is obtained:

$$\dot{\mathbf{X}}_i = (\mathbf{S}_{11} - \mathbf{S}_{13} \mathbf{H} \mathbf{S}_{13}^T) \mathbf{F}_i \mathbf{X}_i + (\mathbf{S}_{13} \mathbf{H} \mathbf{S}_{34} + \mathbf{S}_{14}) \mathbf{U} \quad (18)$$

Where, again, coefficients \mathbf{F} and \mathbf{H} (which is a function of \mathbf{L}) vary as parametric switching coefficients $\boldsymbol{\mu}$ vary.

5. APPLICATIONS

5.1. Mechanical Friction

A common case study for discontinuities in Bond Graphs, previously investigated by Richard et al [8] (among others) is dry friction. In the bond graph framework, this has historically been modelled using switched sources. The use of controlled elements is presented here as an alternative which practitioners may find more physically intuitive.

The most basic and commonly used friction model is coulomb friction, given by:

$$F_c = \varepsilon |F_N| \text{sgn}(v) \quad (19)$$

Here, the friction coefficient is denoted ε to avoid confusion with the hybrid bond graph notation. Coulomb friction only gives friction force for nonzero velocities. When a body is at rest, a static friction (or *stiction*) force must be overcome before this model becomes valid.

Friction force at rest is given by:

$$F_{stick} = \begin{cases} F_e & \text{If } v=0 \text{ and } |F_e| < F_s \\ F_s \text{sgn}(F_e) & \text{If } v=0 \text{ and } |F_e| \geq F_s \end{cases} \quad (20)$$

This yields behaviour shown in Figure 4.

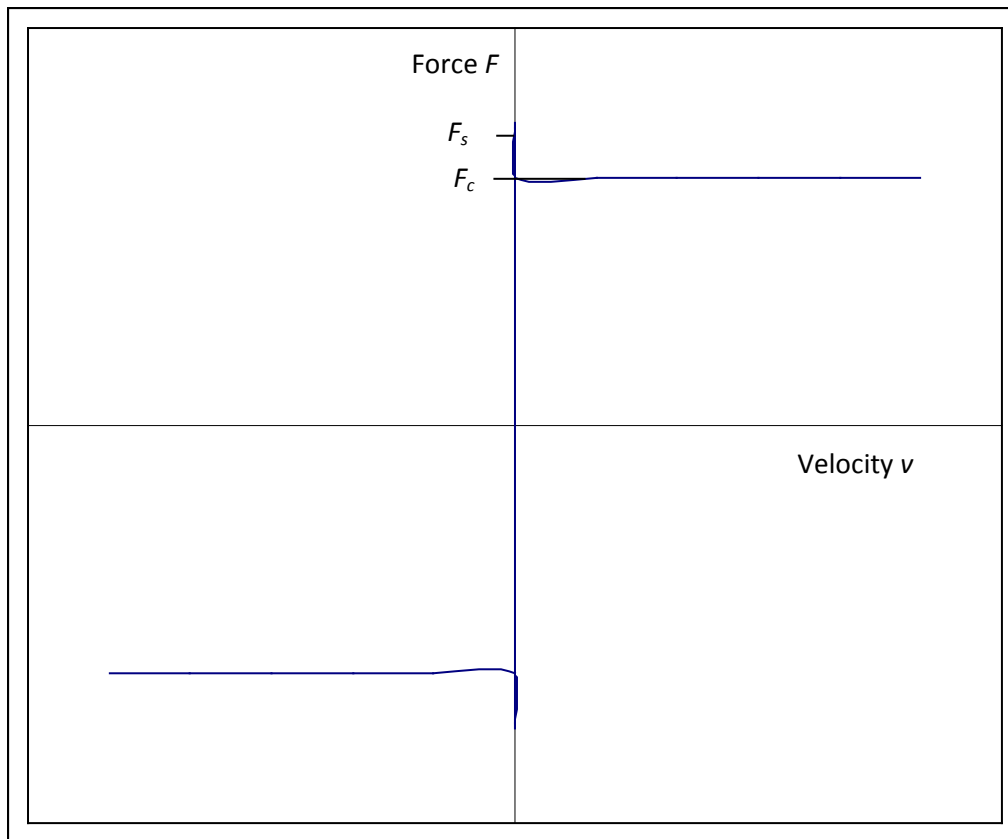

Figure 4: Coulomb and Static Friction Model

Friction is a balance of forces: the applied force minus the friction force. The force normal to the surface (which is usually a function of the body's weight) is also used in calculation.

There are two modes of operation here: kinematic (i.e. velocity is nonzero) and static (i.e. velocity approaches zero). The static mode is further divided into two modes: external force less than F_s , and external force equal to or greater than F_s . This could be represented by a 'tree' of three resistance elements, and concatenated into a controlled resistance (XR) element. Note that v can be taken from the bond graph 1-junction so that it is explicitly shown that commutation is a function of v .

Note that the Automaton in this model is simply a piece of code which evaluates which mode is active and assigns Boolean Values to the junctions accordingly: the exact form will depend on the modelling environment. In the practical implementation of the controlled element, this would take the form of a statement which assigns values of μ depending on the values of the inputs. Note also that capturing the nonlinear behaviour close to $v=0$ in a simulation would require a stiff solver and/or event detection. These practical concerns have been addressed in part [9] and are the subject of further work.

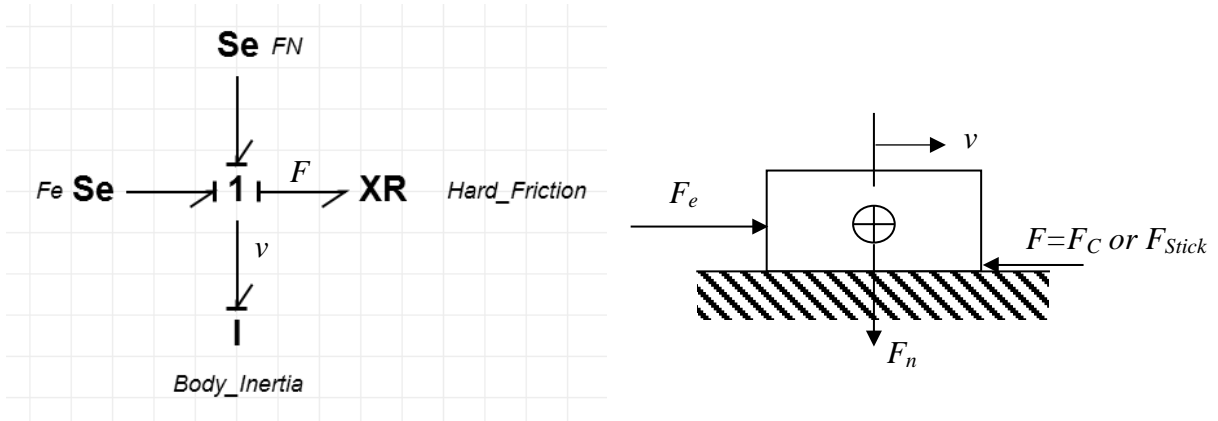

Figure 5: Overview of a Rigid Body on a Flat Surface with Stiction / Friction

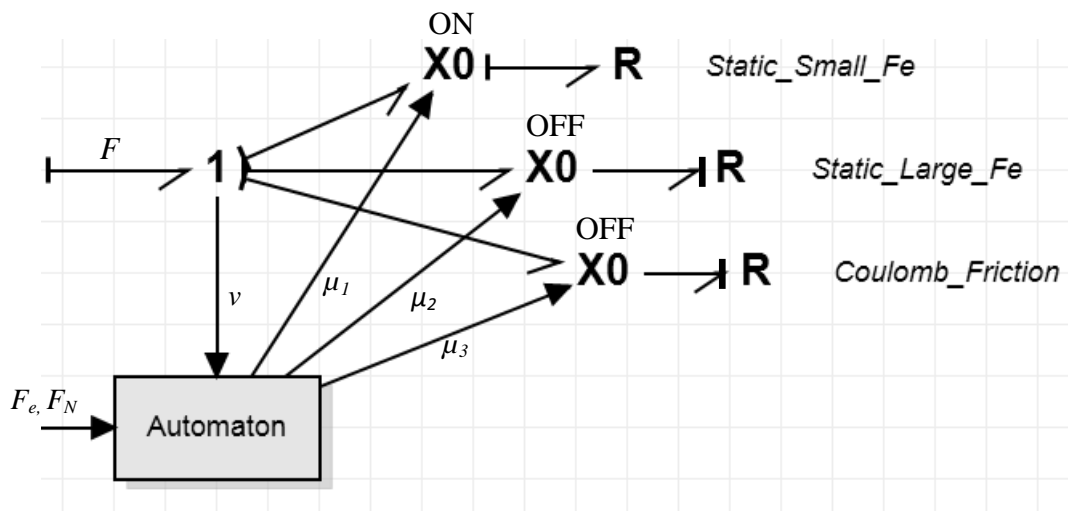

Figure 6: Mode Switching 'Tree' for Stiction / Friction Model

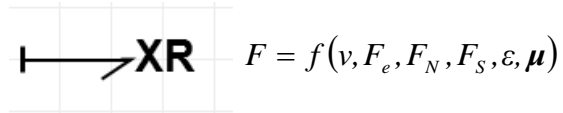

Figure 7: Mode Switching 'Tree' Concatenated into a Controlled Element

5.2. A Hydraulic Valve

A hydraulic valve is analogous to an electrical switch: it inhibits flow when OFF. However, it is an orifice in the ON state and therefore cannot be considered as an ideal switch. This can be simply modelled as a non-ideal switch i.e. a controlled junction connected to a resistance which models the orifice. If it is concatenated into a controlled resistance, it will be causally dynamic and there is no computational advantage. Indeed, the valve should not be represented as a controlled element, since the state of the valve affects the structural analysis of the model: parts of the system are connected and disconnected by the state of the valve (albeit, usually a line to tank which can be neglected).

The orifice equation is, itself, nonlinear. In situations where the square-relationship causes the simulation to slow down, the user may choose to represent it as piecewise continuous. In this case, the hydraulic valve model becomes a controlled resistance with multiple modes of operation. The controlled resistance is still causally dynamic.

The standard equation for a proportional valve is as follows (21). The mode of operation is dictated by the pressure drop. In addition, the resistance is modulated by the valve spool displacement x .

$$Q = C_f A_o \sqrt{\frac{2\Delta P}{\rho}} \quad (21)$$

Where A is generally taken as:

$$A_o \approx \pi dx \cos(\theta) \quad (22)$$

Note that μ_1 and μ_2 are not mutually exclusive: it is now possible for both to be OFF. Further, note that the valve joins to a pipe (via a constant pressure node) and the operation of the valve restricts flow. Therefore, unlike the stiction/friction model, this ‘tree’ of modes contains X1-elements rather than X0-elements. When concatenated into a controlled R-element, this is evident from the causal assignment (effort input, flow output).

As with the previous case study, the automaton in Figure 9 denotes some submodel or code which assigns Boolean values to the controlled junctions. When concatenated into a controlled element (Figure 10), this will be some form of conditional statement.

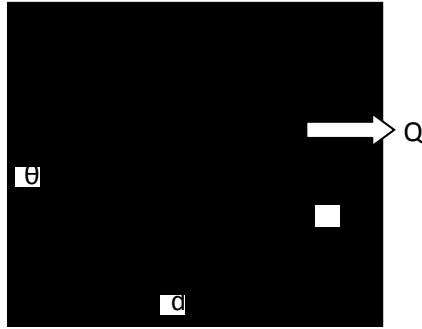

Figure 8: A Single-Stage Poppet Relief Valve.

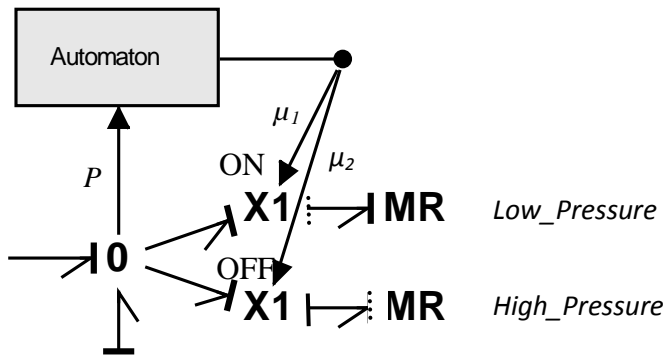

Figure 9: Mode switching 'Tree' for a Single-Stage Poppet Relief Valve.

$$\text{---} \text{XR} \quad Q = f(\Delta P, dx, \mu)$$

Figure 10: Mode Switching 'Tree' Concatenated into a Controlled Element

6. CONCLUSIONS

In this paper, a controlled element is proposed to model 'parametric discontinuities' (i.e. elements represented by piecewise-continuous equations). They concatenate the 'mode-switching tree' representation used in the literature. This is important for two reasons. First, the 'trees' can become large and unwieldy, hampering qualitative structural analysis and generating unnecessarily large mathematical models. Second, the use of controlled junctions in the 'tree' wrongly implies structural switching, which is unacceptable in an idealised physical modelling method.

The General Hybrid Bond Graph is presented as a General Bond Graph with a modified Junction Structure. The hybrid junction structure matrix \mathbf{S} is a function of a structural switching Boolean parameters λ as well as 0 and 1 (and coefficients relating to any transformers or gyrators). In addition, the fields of constitutive equations can now be nonlinear and switching too, and are functions of parametric switching Boolean parameters μ .

Dynamic causality is an inherent feature of the General Hybrid Bond Graph. It is interesting to note that controlled elements internalise any dynamic causality due to switching, and tend to be causally static.

A single state space equation describing all possible modes of operation is generated.

This technique has been demonstrated on the case study of mechanical friction and a hydraulic valve.

Further work includes the automation of equation generation and simulation, an investigation into impacts, and formalising the structural analysis of the causally dynamic hybrid bond graph.

ACKNOWLEDGEMENTS

This work was supported by the EPSRC and Airbus Operations Ltd via a CASE award.

REFERENCES

- [1]. Margetts R. Modelling and Analysis of Hybrid Dynamic Systems using a Bond Graph Approach. University of Bath, 2013.
- [2]. Margetts R, Ngwompo RF, Fortes da Cruz M. Construction and Analysis of Causally Dynamic Hybrid Bond Graphs. Proc. IMechE Part I - J. Syst. and Control Eng. 2013;**227**(3):329-46
- [3]. Borutzky W. Discontinuities in a bond graph framework. J. Franklin Institute - Eng. and Appl. Math. 1995;**332B**(2):141-54.

- [4]. Pollack ME, ed. Formal specifications for hybrid dynamical systems. Proc. 15th Int. Joint Conf. Artificial Intelligence IJCAI-97; 1997; Nagoya, Japan.
- [5]. The Conceptual Side of Mode Switching. Proc. Int. Conf. on Systems, Man and Cybernetics: Systems Engineering In the Service of Humans; 1993; Le Touquet, France.
- [6]. Strömberg JE. A Mode Switching Philosophy [PhD Thesis]. Linköping University, 1994.
- [7]. Gawthrop PJ. Hybrid Bond Graphs using Switched I and C Components. Glasgow, UK.: Centre for Systems and Control, University of Glasgow, 1997.
- [8]. Richard PY, Morarescu M, Buisson J. Bond graph modelling of hard nonlinearities in mechanics: A hybrid approach. *Nonlinear Analysis: Hybrid Systems* 2008;**2**(3):922-51
- [9]. Margetts R, Ngwompo RF. Hybrid bond graphs for contact, using controlled junctions and dynamic causality. 2014 International Conference on Bond Graph Modeling and Simulation, ICBGM 2014, Part of the 2014 Summer Simulation Multiconference, SummerSim 2014. Monterey, CA; United States: SCS, 2014.