



Citation for published version:

Parsons, D, Akehurst, S & Brace, C 2015, 'The potential of catalysed exhaust gas recirculation to improve high-load operation in spark ignition engines', *International Journal of Engine Research*, vol. 16, no. 4, pp. 592-605. <https://doi.org/10.1177/1468087414554628>

DOI:

[10.1177/1468087414554628](https://doi.org/10.1177/1468087414554628)

Publication date:

2015

Document Version

Publisher's PDF, also known as Version of record

[Link to publication](#)

Publisher Rights

CC BY-NC

University of Bath

General rights

Copyright and moral rights for the publications made accessible in the public portal are retained by the authors and/or other copyright owners and it is a condition of accessing publications that users recognise and abide by the legal requirements associated with these rights.

Take down policy

If you believe that this document breaches copyright please contact us providing details, and we will remove access to the work immediately and investigate your claim.

The potential of catalysed exhaust gas recirculation to improve high-load operation in spark ignition engines

International J of Engine Research

2015, Vol. 16(4) 592–605

© IMechE 2014

Reprints and permissions: 

sagepub.co.uk/journalsPermissions.nav

DOI: 10.1177/1468087414554628

jer.sagepub.com



Dominic Parsons, Sam Akehurst and Chris Brace

Abstract

Within the literature, there are a number of studies investigating the benefits of exhaust gas recirculation, and as a result it has become established as a promising technology for combustion control to allow engine downsizing technology to be advanced. Aside from the dilution effect of exhaust gas recirculation, some of the components, such as NO, CO, and hydrocarbons, can have significant chemical effects. The literature shows that the component within exhaust gas recirculation which has the largest chemical effect on combustion is NO, which can promote or inhibit the onset of autoignition causing reactions within the end gas at high load. The reduction in NO_x gases in catalysed exhaust gas recirculation can increase the knock limit at high load, with some authors reporting up to a 5° crank angle improvement in combustion phasing. There is conflicting evidence on whether this translates to an improvement in fuel consumption, with one study finding a decrease of up to 2% comparing to another finding an increase of 1.5%–3.5%. Crude calculations on the emissions of a 2.0-L direct injection spark ignition engine operating at high load show that in an extreme case the reduction in the calorific value of the inlet charge due to catalysis of the recirculated gases can be up to 4.5%. Despite the potential benefits, the literature on catalysed exhaust gas recirculation is fairly limited and the evidence seems so far inconclusive as to whether this technology may have the potential to further enhance the benefits of exhaust gas recirculation. This article uses current literature to ascertain the potential benefits of catalysed exhaust gas recirculation, compare to pre-catalyst exhaust gas recirculation, and investigates its individual components in more detail to explain how chemical interactions can either promote or inhibit ignition depending on their concentration and temperature.

Keywords

Catalysed, post-catalyst, exhaust gas recirculation, high load

Date received: 7 May 2014; accepted: 12 September 2014

Introduction

Engine downsizing is widely considered a promising technology with which to achieve improved efficiency and emissions' performance.¹ The reduction in displacement allows efficiency improvements by a reduction in mass and frictional losses, and a reduction in throttling losses due to the engine running at higher loads for a larger part of its operating range. In response to this, many automotive manufacturers have already started introducing downsized engines to their fleets in order to comply with increasingly stringent emissions and fuel consumption targets, although the extent of this has yet to reach its full potential.

Downsized engines can use increased compression ratios and boost pressures to improve their volumetric efficiency, in order to achieve comparable performance to their larger counterparts. However, the level by

which these can be increased is knock limited, leading to the need for knock control strategies to be employed.

Traditional methods to control knock involve spark retardation to reduce the peak pressure and temperature in the cylinder, with overfuelling at high loads to protect exhaust components from excessive temperatures, but this can significantly reduce the efficiency of an engine due to both non-optimal combustion phasing and excess fuel wastage. This has prompted research into more novel combustion control methods to allow

Department of Mechanical Engineering, University of Bath, Bath, UK

Corresponding author:

Dominic Parsons, Department of Mechanical Engineering, University of Bath, Bath BA2 7AY, UK.

Email: D.Parsons@bath.ac.uk

an engine to run at higher boost and compression ratios, including the following:

- Lean boost – the addition of excess air to the inlet charge;²
- Turboexpansion – the over compression of the inlet charge, cooling, and then re-expansion to achieve lower charge temperatures.³

However, one of the most promising technologies for this purpose is widely believed to be exhaust gas recirculation (EGR)⁴– the introduction of a proportion of the burned exhaust gases back to the inlet charge, which can allow an engine to run at stoichiometric conditions throughout its operating range with high compression ratios and spark timing closer to optimal.⁵

Previous work on the effect of EGR

Knock is caused by autoignition within the end gas, which is heavily influenced by the end gas temperature– and pressure–time histories.⁶ These are influenced by three factors, as identified by Grandin et al.:⁷ heat transfer, compression, and chemical reactions. EGR will increase the mass of the in-cylinder mixture, therefore reducing the temperature rise via heat transfer and slowing the combustion rate to reduce peak pressures. However, this is counteracted to some extent by a reduced specific heat capacity of the charge since the mass fraction of fuel (which has a higher specific heat capacity (C_p) than the exhaust gases) in the charge is reduced by dilution resulting in a higher specific heat ratio (γ). And despite EGR often being described as the introduction of inert gases to the inlet charge, the chemistry of combustion is also affected by some of the components present in the exhaust gases, the most potent of these being NO, CO, and unburnt hydrocarbons (HCs).

Aside from its benefits in knock control, EGR has also been shown to provide significant economy benefits during part-load operation where optimal combustion phasing can be achieved without EGR.⁸ This is due to the effect EGR has at these conditions of dethrrotting the engine by displacing some of the inlet air, reducing the need for physical throttling to limit airflow into the cylinders.

EGR rates are normally measured by comparing the ratio of CO₂ concentration between the exhaust and inlet manifolds, as shown in equation (1), which applies to all applications where the inlet composition is not altered by injection of additional components into the manifold

$$\text{EGR rate} = \frac{\text{Intake CO}_2 - \text{Background CO}_2}{\text{Engineout CO}_2 - \text{Background CO}_2} \quad (1)$$

This will give a reliable measurement of the quantity of exhaust diverted to the inlet as long as the reference

CO₂ quantity in the exhaust remains constant after being expelled from the cylinder. This may not be the case where there is oxidation of the exhaust gases post-measurement, from catalysis or continued oxidation after incomplete in-cylinder combustion, or under transient conditions due to the lag time in the measurement.

There are many studies in the literature which investigate the benefits of EGR at high-load and part-load operating conditions. An early example of one of these studies was published by Ricardo⁹ as early as 1919 with an experimental investigation into the effect of EGR on knock control. It describes how an inert gas added to the inlet can ‘insulate the particles of fuel and air from each other, thereby delaying the rate of flame propagation’, which allowed a significant increase in the compression ratio without the onset of knock.

More recently, Cairns and colleagues^{1,10,11} have conducted a number of studies comparing the benefits of EGR against other knock control technologies such as lean boost and overfuelling. Their findings were clear that EGR was a significantly more effective knock suppressant than either excess air or fuel, with large fuel consumption benefits of up to 17% at high load coming from the elimination of the need for overfuelling, and significant CO, CO₂, and HC emissions improvements were also observed. (It should be noted that the CO and HC emissions are very sensitive to variations in relative air–fuel ratio (λ), as highlighted by Alger et al.,¹² so a large part of the emissions benefits may stem from this.) These studies confirm previous work done by Grandin and Ångström,^{13,14} which also highlights the benefit of EGR allowing a stoichiometric charge to be maintained across the full operating range which in turn allows effective operation of a three-way catalyst (TWC).

Comparisons of possible EGR architectures

Within the scope of EGR operation, the potential architectures can take a number of forms. For the most part, these vary by the location from which the exhaust gases are sourced (pre- or post-turbine) and the location where the recirculated exhaust gases are introduced at the inlet side (pre- or post-compressor). A large number of studies focus on either high pressure (HP; Figure 1(b)) – pre turbine to post-compressor – operation or low pressure (LP; Figure 1(a)) – post-turbine to pre-compressor – operation, with some also including mixed high pressure and low pressure (HP–LP) operation (Figure 1(c)).

Vitek et al.¹⁵ used simulation methods to compare the effect of four different cooled EGR architectures on a diesel engine over the New European Drive Cycle (NEDC). Their results showed that during steady-state operation at some points on the NEDC cycle, the LP layout showed as much as an 8% brake-specific fuel consumption (BSFC) reduction in comparison to the

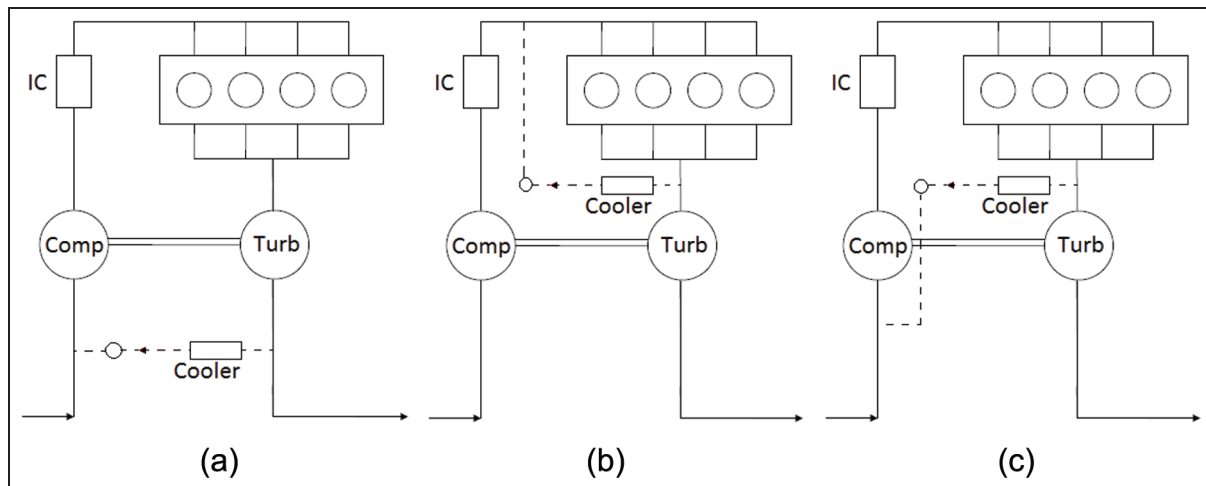

Figure 1. Illustration of the three primary EGR architectures (the EGR route is shown by the dashed line IC denotes intercooler): (a) low-pressure architecture, (b) high-pressure architecture, and (c) mixed pressure architecture.

other architectures. Combining this with the capability of the LP architecture to provide sufficient EGR rates across the entire operating map showed a significant advantage for this layout, despite a poorer transient response than the HP alternatives.

A similar study was conducted by Potteau et al.¹⁶ on a spark ignition (SI) engine which investigated four different EGR architectures via simulation before investigating an HP (Figure 1(b)) and LP (Figure 1(a)) architecture in more detail on an experimental engine. The LP EGR loop was in fact sourced from downstream of the catalyst, which would change the chemical composition of the gases introduced to the inlet charge in comparison to the non-catalysed HP loop, and therefore introduces a further variable when comparing the two architectures.

A common problem observed with HP architectures is the availability of a positive pressure differential across the operating map between the inlet and exhaust manifolds to drive the EGR flow. For this reason, Potteau et al.¹⁶ used a throttle upstream of the EGR inlet to create a pressure differential to drive the EGR flow in HP mode. Despite this, they still found the system incapable of producing the required pressure differential at low-speed, high-load parts of the operating range. They observed a 6.6% BSFC improvement for the HP architecture over non-EGR operation, which compared to a 13.6% improvement for the LP architecture at similar conditions (5500 r/min, 12.9 bar brake mean effective pressure (BMEP)). A large part of this may be attributable to the knock-limited spark advance being only improved by 5° crank angle (CA) for the HP layout, compared to 10° CA for the LP architecture. They concluded that this could be due to both cooler recirculated exhaust gases in the LP layout, and the effect on combustion of the decreased of HC and CO levels due to catalysis of the recirculated exhaust gases.

Alger et al.¹² investigated the use of an uncooled HP EGR loop at low loads and a cooled LP loop for high

loads on an SI engine. Although its significance is not mentioned in the study, the LP architecture used the same configuration as that in Potteau et al.'s¹⁶ study and sourced the exhaust gases from downstream of the catalyst. The effect that this would have on the chemical composition of the exhaust gases is not discussed, but despite this the authors conclude that the cooled LP EGR configuration is preferable for knock prevention at high loads (where a BSFC reduction up to 26% was observed due in large part to the elimination of overfueelling), and the hot HP EGR at part loads to help maintain combustion stability while also thermally dethrottling the engine (where a BSFC reduction of up to 3% was observed).

Turner et al.¹⁷ focussed their investigation on the high-load operation (at 5000 r/min) of an SI engine employing an integrated cooled exhaust manifold with a comparison of an HP, LP, and an HP-LP EGR configuration. Their data were for comparatively low EGR rates (up to 6%) which are significantly lower than those used previously in the literature. They concluded that the different architectures had a larger impact on the charging system than they did on the combustion system, and that the LP architecture appeared to offer the least benefit. They also noted that the turbocharger was not well matched to the engine, and that with a less restrictive turbine the EGR benefits may have been significantly improved. Furthermore, the matching of the turbocharger to the engine could have differing effects for each of the EGR configurations. This further highlights the complexity involved in the comparison of different EGR systems.

High- and mixed pressure EGR systems

Several studies have focussed purely on HP EGR to ascertain its benefits versus either lean operation or overfueelling. Galloni et al.¹⁸ and Hattrell et al.¹⁹ used simulation methods to confirm the advantages of

EGR, and experimental investigations by Grandin and Ångström^{13,14} and Fontana and Galloni²⁰ provide further confirmation that cooled HP EGR can provide significant fuel consumption benefits (varying between 6% and 15% BSFC reduction at high load between the different studies) where the engine speed is high enough to provide a sufficient pressure differential between the exhaust and inlet ports to drive the EGR flow.

Cairns et al.¹¹ compared EGR supplied post-compressor (HP) to that supplied pre-compressor (HP-LP) and concluded that although the HP loop was favourable for transient response, it was not possible to drive the EGR rate through the full operating range due to an insufficient pressure differential between the exhaust and intake manifolds. They go on to say that although an LP EGR architecture was not investigated, it may improve on the HP-LP architecture that they did test due to lower cooling demands of the post-turbine gas.

LP EGR systems

LP EGR systems are a very active area of research, but research has primarily focussed on the dilution effects of EGR rather than the chemical effects on combustion. Kaiser et al.²¹ investigated an LP EGR architecture on a twin turbocharged V6 SI engine, citing the main advantage of LP EGR as that 'it enables EGR to flow at lower engine speeds where engine knock limited combustion is more of a problem'. Bourhis et al.²² investigated a similar architecture but with post-catalyst sourced EGR in combination with internal exhaust gas recirculation (IGR) through variation in valve overlaps. They found significant fuel consumption benefits of up to 20 g/kW h at part load which they attributed more to variable valve timing (VVT) optimisation rather than the effect of the EGR.

Hoepke et al.²³ also investigated an LP EGR system on a boosted gasoline direct injection (GDI) SI engine and confirmed that it extended the knock limit due to lower end gas temperatures. Their experimental investigations showed maximum fuel consumption benefits of 3%, which compared to 5% predicted by simulation.

Other factors within EGR operation

Topinka et al.²⁴ investigated the effect of H₂ and CO, both in isolation and combined, on combustion. They found that both compounds can increase the knock limit in an SI engine, attributing the improved combustion performance to the higher octane ratings of these substances, quoting an estimate of 106 for the octane number of CO, and a previous study²⁵ finding H₂ to have an octane number of around 130. This has led to investigations into the reforming of recirculated exhaust gases through a catalyst with the introduction of fuel to produce hydrogen-rich gas at the inlet. One such investigation, conducted by Fennell et al.,²⁶ shows improved combustion stability with reformed EGR

during low-load operation, allowing higher recirculation rates. Although an improvement in combustion was observed, Fennell et al. found no improvement in fuel consumption, primarily due to losses during the reforming process. It must be mentioned that IGR has also been investigated through the use of variable valve trains, where in-cylinder residuals can be increased by a negative valve overlap, effectively introducing hot exhaust gases to the unburned mixture in the cylinder which can reduce throttling requirements and improve part-load performance of the engine.²⁷

Evidence from the literature suggests that any EGR architecture involves a certain extent of compromise, be it the slower transient response of LP EGR, or the insufficient pressure differential to provide HP EGR flow across the full operating map. Furthermore, the benefits available from EGR operation can fall into two categories: part-load dethrrottling for improved efficiency where hot EGR can be more beneficial for combustion stability or high-load knock suppression for optimised combustion phasing, where cooled EGR can be more effective at extending the knock limit.

Comparison between studies

Table 1 shows a basic comparison of some of the studies concerning LP EGR at high load with a focus on the maximum observed fuel consumption benefit over operation without EGR. The data initially appear to support the theory that catalysed EGR may be more effective than un-catalysed EGR. However, this is a superficial comparison; although it does present a promising picture for catalysed EGR, other variations in experimental conditions may be more significant for the trends shown.

Studies focussing on catalysed EGR

Grandin and Ångström¹³ state that the end gas reactions can also be reduced 'by either lowering the temperature of the end gas, or by decreasing the concentration of radicals by chemical intervention'. A TWC converts NO_x, CO, and HCs into N₂, CO₂, O₂, and H₂O, therefore altering the chemical compounds available from EGR if it is sourced from downstream of the catalyst.

Several investigate the use of a catalysed EGR system in an LP architecture without any mention of the chemical significance of this and without any comparison of performance between the catalysed loops and equivalent un-catalysed loops.^{12,16,22} Very few examples can be found in the literature where this kind of comparison has been made.

Roth et al.²⁹ considered the advantages of operating an SI engine with BMEP values reaching 17 bar with both LP and HP EGR configurations available to cover the full operating range. Within this study, the authors experimentally compared the effect of post-catalyst versus pre-catalyst EGR for the LP loop. They concluded

Table 1. Comparison of maximum BSFC improvements relative to operation without EGR using low-pressure EGR systems at high load.

Source	Speed (r/min)	BMEP (bar)	EGR (% from CO ₂)	BSFC improvement vs non-EGR operation (%)	
Potteau et al. ¹⁶	1500	11.3	8	7.4	Catalysed
	5500	12.9	12.2	13.6	
Alger et al. ¹²	2000	14	19.5	7.5	Catalysed
	2000	18	14	7	
	3000	18	15	4	
	4000	18	10	19	
	4500	17	18.5	16	
	5500	15	18	24	
Cruff et al. ²⁸	2000	15.7	15.5	3.1	Non-catalysed
	3000	15.7	15.5	4.2	
	5000	15.7	15.5	5.4	
Hoepke et al. ²³	1500	14	9	-0.5	Non-catalysed
	2000	14	18	2.9	
	2500	14	18.5	3.1	

EGR rates are measured by the CO₂ ratio between the inlet and exhaust manifolds. BMEP: brake mean effective pressure; EGR: exhaust gas recirculation; BSFC: brake-specific fuel consumption.

that pre-catalyst EGR was preferable to catalysed EGR because of the following:

The average BSFC was improved by 1.5%–3.5%, with a higher power production observed for all points despite having up to 5° CA less favourable combustion phasing due to knock.

The combustion rate was faster.

HC emissions were lower by 30%–40%.

Pumping mean effective pressure (PMEP) was reduced by 5%–15% at higher speeds and loads.

The pressure differential available to drive the EGR was larger due to the pressure loss over the catalyst, allowing a reduced EGR valve size and larger delivery range.

Roth et al.²⁹ do mention that a significant amount of IGR, which is of course un-catalysed, was present at some of their test points and therefore could have affected the data produced. At a reference 10% external EGR rate, they record an IGR fraction from 8% up to 48%, dependent on speed, load, and valve timing. This could be a factor in explaining differences between results found in this study and others, where valve timing events may have allowed for more scavenging and therefore lower in-cylinder residuals.

It must also be noted that during their investigation, Roth et al.²⁹ measured the external EGR rate by calculating the ratio of CO₂ measured in the intake to that in the exhaust manifold (equation (1)). This inherently carries an error when calculating the EGR rates with catalysed exhaust gases since the CO₂ content is increased when the gases pass through the catalyst by conversion of the CO molecules. This error could mean that for a given EGR rate, the total quantity of exhaust gases being recirculated could vary between pre- and post-catalyst operation, and therefore may slightly complicate the results being presented.

Hoffmeyer et al.³⁰ studied the effects of catalysed EGR with an HP EGR loop on a 2-L four-cylinder turbocharged SI engine and a catalyst within the EGR loop. The authors used a similar process to measure the EGR rate as Roth et al.,²⁹ but calculated that the catalytic process only introduced an error of less than 2% in their study. This is surprising, considering that one of their test points was not operated with a constant lambda, and air–fuel ratio is known to have a large impact on exhaust CO content¹² which would then affect the CO₂ increase post-catalyst.

In contrast to Roth et al.'s²⁹ study, Hoffmeyer et al.³⁰ found an improvement in fuel consumption of up to 2% with the catalysed EGR compared to that of the non-catalysed loop, which they attribute to earlier combustion phasing (1.5°–3° CA) as a result of the increased knock tolerance of the engine. They cite the increased heat capacity of the inlet charge due to the increased CO₂, and the reduction in NO and HCs after catalysis as the primary reasons for the increased knock limit.

In consideration of the products involved, Hoffmeyer et al.³⁰ conducted a sensitivity study to evaluate the contribution of each EGR component on ignition delay time. Their results are shown in Figure 2, where it can be seen that after catalysis the increase in ignition delay stems primarily from the reduction in NO and C₂H₂.

Very recently, research has been conducted at the University of Bath by Lewis et al.³¹ on an SI engine with BMEP levels reaching 26.5 bar and a catalyst installed in the EGR loop. Concerns over errors introduced by measuring the EGR rate via the CO₂ ratio between the inlet and exhaust manifolds prompted them to use the mass airflow into the engine as a measure instead. This means that their investigation is carried out with a constant total airflow into the engine (air + EGR) rather than a constant load on the engine,

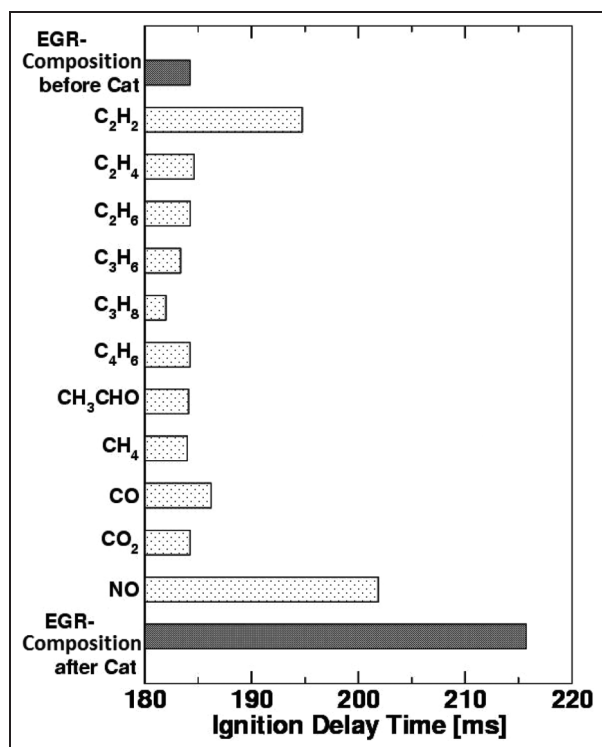

Figure 2. Results of a sensitivity study by Hoffmeyer et al.³⁰ comparing the ignition delay time contributed for each EGR component with EGR compositions pre- and post-catalyst (operating at 17.5 bar IMEP and 2500 r/min). EGR: exhaust gas recirculation; IMEP: indicated mean effective pressure.

and as such the load and fuelling decrease with higher EGR rates due to the reduction in oxygen in the charge and the engine being set to maintain stoichiometry.

Lewis et al.³¹ found an increase in the knock limit of up to 6° CA with catalysed EGR for equivalent EGR mass flows, but at equivalent BMEP values the BSFC was found to increase by up to 10%. This is attributed to the lower calorific value of the charge for catalysed EGR due mainly to the oxidation of HCs and CO in the catalyst. One point that was highlighted was that the engine-out CO and HC emissions were considerably higher than would be expected for stoichiometric in-cylinder operation. They concluded that this was due to the blow-through of fresh air due to valve timing overlaps, causing the engine to be running rich in-cylinder despite the exhaust lambda sensors showing it to be running at stoichiometry. Another effect of rich in-cylinder conditions is that NO_x emissions are relatively low, so the catalysis of the exhaust gases in this study would have offered little benefit from the reduction in EGR NO_x content.

Effect of NO on combustion

NO is a highly reactive substance and as such can have a significant impact on the combustion process. A summary of some data from the literature concerning the

effect of NO on autoignition for various engine operating conditions and fuels is shown in Table 2.

As can be seen from Table 2, the combustion process is very sensitive to NO concentrations, fuels used, and initial conditions, so comparisons between different studies must be made cautiously. In general terms, NO will usually promote autoignition with increasing effect to an upper limit of concentration, beyond which it will retard the ignition. This promoting effect is observed for all fuels with one exception shown in the literature, this being iso-octane as tested by Burluka et al.,³² where the NO showed an inhibitory effect on autoignition.

Both Prabhu et al.³⁶ and Risberg et al.'s³⁷ studies confirm that the initial temperature of the charge has a large impact on the autoignition promoting effect of NO on both SI and homogeneous charge compression ignition (HCCI) engines, with a higher initial temperature extending this effect to higher concentrations for all fuels. Risberg et al.³⁷ go further in confirming that the initial temperature has a larger effect on the combustion chemistry than the initial pressure. When comparing the data from this study with that from Burluka et al.³² on a ported SI engine, the trends in results seem largely similar for each different fuel, with toluene reference fuels (TRFs) having much more similar characteristics to gasolines than primary reference fuels (PRFs).

The findings of Burluka et al.,³² where the effect of NO on autoignition was negligible with PRFs, are not reflected in Risberg et al.'s³⁷ study on an HCCI engine where some autoignition promoting effect is observed. Risberg et al. found the PRF to be sensitive to trace amounts of NO, but the promoting effect soon disappeared once the concentration was increased. This effect may be explained by the promoting effect NO has at low/intermediate temperatures on high-octane fuel components such as iso-octane and toluene, as well as its inhibiting effect on low octane components such as n-heptane.⁴⁰

Roberts and Sheppard³⁹ expand further on the mechanisms behind NO effects on different fuels and with different inlet temperatures. They highlight the significance of the negative temperature coefficient (NTC) region, which is more prominent for some fuels than for others. The NTC occurs at the point where the low-/intermediate-temperature oxidation chemistry begins to slow down with increasing temperature, but below the temperature at which the high-temperature oxidation chemistry becomes the dominant mechanism, and so in this region a reduction in reactivity is observed. They found that for fuels exhibiting more pronounced NTC behaviour (e.g. PRFs), NO will suppress normal autoignition chemistry if the pressure temperature history of the end gas falls within the NTC region for a significant time before autoignition, with the opposite being true for fuels exhibiting little or no NTC behaviour (such as TRFs and unleaded gasolines (ULGs)). This could explain the variation in results obtained by various authors in Table 2, especially where HCCI results differ from those obtained with SI ignition.

Table 2. Summary of data taken from the literature concerning the effect of NO on hydrocarbon oxidation.

Author	Experiment	Variables	MAT (°C)	Fuel	Speed (r/min)	NO concentration (ppm)	Results
Burluka et al. ³²	Experimental and simulation ported single-cylinder SI engine with simulated EGR (CO ₂ , N ₂ , NO, and H ₂ O), skip-fire ratio of 7	Fuel, NO concentration	70	3 PRFs TRF2 iso-octane	1500 (WOT)	0–400	iso-octane: increasing NO concentration from 0 to 400 ppm resulted in a delay in knock onset time of up to 4° CA, so KLSA was advanced PRF: NO concentration had very little effect on knock (authors propose that repressive effect on iso-octane may have been offset by an autoignition promoting effect on the n-heptane in the mixture) ULG and TRF: knock onset advanced by up to 2° CA by introducing trace amounts (100–200 ppm), further increase in NO concentration did not advance knock further
Stenlaas et al. ³³	Simulation	Lambda, NO concentration	137–159	PRF	?	0–1408	Simulation model finds maximum influence of NO on autoignition timing at 500 ppm, but states that data must be taken qualitatively rather than quantitatively
Kawabata et al. ³⁴	Experimental single-cylinder gas engine	NO concentration	57	Natural gas	1000	0–400	NOx concentration increase advanced autoignition timing and increased knock intensity with almost linear relationship, by up to 7° CA and 170 kPa at 400 ppm
Stenlaas et al. ³⁵	Experimental four-cylinder 2.3-L SI engine	Lambda, NO concentration	?	Gasoline	1000–4000	100–1600	No effect on exhaust temp found with addition of NO Increased concentrations of NO resulted in increased knock intensity and advanced the angle of knock onset by up to 6° CA Lambda variations did not alter the effect of NO, but rich mixtures were more prone to knocking
Prabhu et al. ³⁶	Experimental single-cylinder four-stroke SI engine compression ratios 5.2 and 8.2	Inlet charge temperature, NO concentration	6074 127172	PRF	900	0–400	Low MAT: NO promoted autoignition up to 100 ppm and retarded from then on High MAT: promoting effect of NO extended up to 400 ppm No pressure/combustion data from the lower compression ratio
Risberg et al. ³⁷	Experimental single-cylinder HCCI engine	Fuel, MAT/MAP combination, NO concentration	40100	PRF TRF Gasoline	900 and 1200	0–476	High MAP (2 bar, 40 °C): PRF – NO advanced combustion by around 2° CA at 15–48 ppm NO; at higher concentrations the promoting effect reduced and 448 ppm retarded combustion TRF – all concentrations advanced combustion, up to 9° CA for 476 ppm ULG – all concentrations advanced combustion up to 4° CA at 229 ppm High MAT (1 bar, 100 °C): PRF – all concentrations advanced combustion up to 8° CA at 240 ppm TRF – all concentrations advanced combustion up to 12° CA at 207 ppm ULG – all concentrations advanced combustion up to 12° CA at 307 ppm HCCI combustion reported to be more sensitive to NO addition than SI

(continued)

Table 2. (continued)

Author	Experiment	Variables	MAT (°C)	Fuel	Speed (r/min)	NO concentration (ppm)	Results
Dubreuil et al. ³⁸	Experimental four-cylinder HCCI engine, one-cylinder active	Fuel, simulated EGR addition, CO, CH ₄ , NO addition	53–118	n-Heptane 75% n-heptane/25% iso-octane/80% n-heptane/20% toluene	1500	0–500	No effect of intake CO and CH ₄ addition was found. NO had a maximum promoting effect on autoignition timings at 100 ppm of 1.5° CA, beyond which the effect reduced with increased concentrations.
Roberts and Sheppard ³⁹	Experimental single-cylinder ported SI engine with skip-fire ratio of 9	Fuel type, simulated EGR addition, NO concentration	70–110	Iso-octane/PRFTRFULG	1500	0–774	Iso-octane: knock onset was advanced by up to 1.9° CA at 387 ppm of NO (7.5% sEGR)/95PRF: knock onset was advanced by up to 1.1° CA at 387 ppm of NO (7.5% sEGR)/90PRF: knock onset time was not affected by 258 ppm NO (5% sEGR) and was delayed at concentrations higher than this up to 0.8° CA at 774 ppm NO (15% sEGR)/90TRF: knock onset was advanced by up to 3.2° CA at 762 ppm NO (15% sEGR)/90ULG: knock onset was advanced by up to 3.9° CA at 768 ppm NO (15% sEGR)

MAT: manifold air temperature; EGR: exhaust gas recirculation; PRF: primary reference fuel; TRF: toluene reference fuel; CA: crank angle; ULG: unleaded gasoline; SI: spark ignition; HCCI: homogeneous charge compression ignition; MAP: intake manifold absolute pressure; sEGR: synthetic exhaust gas recirculation; WOT: Wide open throttle; KLSA: knock-limited spark advance.

Note: ? Denotes an unknown quantity for that value in the table.

Surprisingly, lambda values have been found not to have a significant impact on the effect of NO on combustion.³⁷ Stenlaas et al.³⁵ confirmed this with experimentation on an SI engine, but the lower lambda values did show an advanced knock angle compared to lean operation. A surprising result from this particular study is that the inhibitory effect of NO was not observed at high concentrations. The inlet temperature is not divulged so it is hard to assess whether it may be a contributory factor, and the effect of the higher operating speeds in this study may also have had an impact. Considering the evidence presented in Table 2, it can be seen that the effect of NO on combustion is a complex mechanism involving not only concentration of NO but also initial temperature, fuel composition, and initial pressure (to a lesser degree).

HC oxidation mechanism

Faravelli et al.⁴¹ investigated the kinetic modelling of HC oxidation and the interaction with NO. They state that the temperature for the onset of HC oxidation can typically be reduced by 100–200 K by trace amounts of NO and go on to say that ‘NO_x can significantly catalyse the oxidation and autoignition of fuels in engines’. This is a mutually sensitised reaction as it is accompanied by the conversion of NO to NO₂.

Models for the HC oxidation mechanism can consist of up to 5000 reactions involving up to 250 species.⁴¹ In simple terms, the reaction rate during combustion is heavily influenced by the availability of OH radicals and at intermediate temperatures by the availability of HO₂. These radicals are formed by branching reactions, which are dictated by the temperature region. There is some variation in the literature in defining the temperature regions, with different authors claiming the range for the intermediate-temperature regime to be as follows: 700–800,⁴² 680–980,⁴³ 800–1050,⁴⁴ 850–1200,⁴⁵ and 750–950 K.⁴⁵ The low-, intermediate-, and high-temperature regimes are defined by the chemical mechanisms that operate in those regimes, and for different fuel compositions and pressures this can vary, resulting in the boundaries for the different temperature regions not being well defined.

In production engines, autoignition usually occurs at temperatures of 800–900 K, and therefore primarily occurs during the low- and intermediate-temperature regions of combustion.⁴⁶ At temperatures below 850–950 K, the addition of O₂ to the alkyl radical (R, usually of the form C_nH_{2n+1}) is favoured, forming a peroxy radical, as shown in equation (2)



The peroxy radical undergoes internal H-atom abstraction (equation (3)), which is illustrated in Figure 3, and is essentially the relocation of a hydrogen atom from its original bond with a carbon atom to bond with the oxygen atom at the end of the chain.⁴⁶

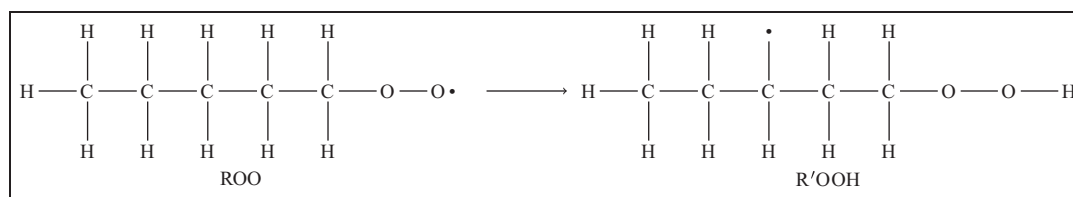
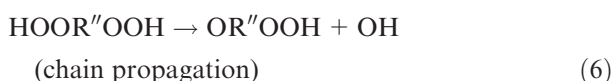
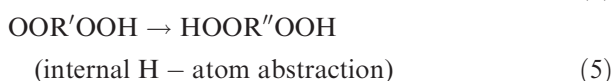
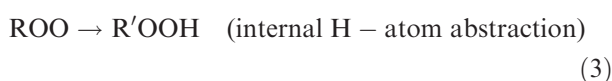

Figure 3. Illustration of equation (3), with an example peroxy radical (ROO) forming an R'OOH radical by internal H-atom abstraction.

Further oxygen addition (equation (4)) has a chain lengthening effect resulting in a very unstable molecule. This molecule can undergo another internal H-atom abstraction via reaction (5) which results in chain propagation and chain branching of the resulting molecule (equations (6) and (7)), creating an OH radical pool for ignition.



At intermediate temperatures, the component formed in reaction (4) decomposes back to an alkyl hydroperoxy radical (R'OOH), which in turn decomposes to form OH or HO₂ radicals, and this can happen through three different reaction paths



At temperatures over 850 K, the alkyl radicals are favoured, resulting in the preferred path becoming



In this intermediate-temperature regime, there is a reduction in reactivity as the temperature rises (often referred to as the NTC), which is due to both the reverse of reaction (4) occurring and the lower reactivity of HO₂ radicals compared to OH radicals.

NO_x mechanism

The kinetic mechanisms involved for the interaction of NO in HC oxidation are well documented in the literature.^{35–38,40,41,47} To fully understand the behaviour exhibited by NO addition to combustion, it is necessary to consider the kinetic effects.

The main influence of the NO is to 'increase the chain length and provide a more rapid build-up of the radical pool'.⁴¹ NO combines with peroxy radicals via



In addition to this, NO promotes the conversion of the relatively unreactive HO₂ radicals in to OH radicals via



NO is also formed from NO₂ by

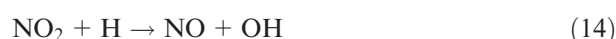

The net effect of reactions (13) and (14) is



which is more active than the recombination reaction



As it can be seen from reactions (12)–(16), NO has a significant effect on the promotion of reactive OH radicals and therefore promotes reaction rates and increases autoignition occurrence. At high concentrations, however, NO has an inhibitory effect on ignition. This is explained by the following reaction paths described by Stenlaas et al.,³⁵ Prabhu et al.,³⁶ Risberg et al.,³⁷ Dubreuil et al.,³⁸ and Faravelli et al.⁴¹

Excessive concentrations of NO result in the scavenging of OH radicals via



And excess NO₂ can also react via



The inhibiting effect is the result of both the competition between reactions (13) and (19) and chain termination effect of reaction (18). As the temperature rises further (> 1000 K), the importance of peroxy radicals diminishes, which reduces the enhancing effect of NO.⁴¹ This explains why NO is predominantly significant in the earlier stages of combustion where autoignition is a prominent issue, but has not been observed to have a significant effect on combustion duration or exhaust temperature.³⁵

Effect of other exhaust components on combustion

CO

Dubreuil et al.³⁸ found no effect on an HCCI engine with the addition of CO to the inlet, although they state

that 'CO has an accelerating potential, more particularly in the case of intermediate and high temperatures mode'. Furthermore, Topinka et al.²⁴ investigated the addition of CO and H₂ in combination and in isolation on an SI engine. They stated that the addition of CO increases the effective octane number of the fuel and lengthens the ignition delay and rated the research octane number (RON) of CO to be 106. Topinka et al.²⁴ proposed two methods for estimating the total octane number for a mixture of components with different octane numbers. The first is an energy-weighted average which weights the octane number according to the lower heating value (LHV) and the mass fraction of each component. The second method is a bond-weighted average, which uses the number of critical bonds per molecule and molar fraction of each component. They define the number of critical bonds as those 'that could take part in the spontaneous ignition process', for example, the H–C bonds in HCs. This definition is clouded somewhat in their estimation of the number of critical bonds in CO, which 'is between two and three', but this method does highlight the significance of a component's volatility in assessing octane ratings.

The findings of Topinka et al.²⁴ on the impact of CO on autoignition highlight the point of Dubreuil et al.³⁸ stating that the accelerating potential of CO will take effect at higher temperature modes. This evidence suggests that in the low- to intermediate-temperature region (< 900 K) where autoignition will usually occur, CO will in fact help to increase autoignition delay times, but will help to accelerate combustion above this temperature. Both these qualities are beneficial for knock prevention, since for a constant start of ignition an increased flame speed will reduce the time over which the end gas will heat up due to radiation and will increase the chance of the flame enveloping the end gas before autoignition has occurred.

The conversion of CO to CO₂ in the catalyst also results in an increased quantity of CO₂. The CO₂ has no significant chemical effect on the kinetics of combustion, but it does provide the thermodynamic effect of increasing the heat capacity of the end gas, which slows the flame propagation during combustion.³⁰

H₂O

As with any additive, the effect of the addition of HCs will depend on the RON of the HCs added in comparison to the RON of the fuel. In the sensitivity analysis of each EGR component on ignition delay time conducted by Hoffmeyer et al.³⁰ (shown in Figure 2), they pick out C₂H₂ and C₃H₈ as the HCs, which have any significant effect on ignition timing.

C₂H₂ has a high knock tendency in comparison to saturated HCs⁴⁸ and reacts via equation (20) to form OH radicals



The removal of C₂H₂ from EGR tends to increase the ignition delay and therefore reduce the tendency to knock. C₃H₈ has a high RON, so will increase the ignition delay for most fuels. Its removal from EGR therefore reduces the ignition delay, but with less effect than both NO and C₂H₂.³⁰ The sensitivity study conducted by Hoffmeyer et al.³⁰ (illustrated in Figure 2) found that other HCs that may be present in recirculated exhaust gases had little or no effect on ignition delay.

H₂O

One component that is not considered in detail by many studies concerning EGR is water. As a product of combustion, it can make up over 12% of emissions,³⁰ but this quantity is also affected by catalysis of HCs for which water is also a by-product. Existing studies on water injection have shown that it can have a large effect on reducing combustion temperatures and therefore, it reduces the tendency to knock; however, this is mostly attributed to the energy absorbed through its vaporisation.⁴⁹ With the water content of EGR mostly being vaporised, this removes any effects of its latent heat and so it acts to slow the early stages of combustion via mixture dilution alone. At high temperatures of up to 2000 K, however, H₂O can dissociate into H₂, O, H, and OH and therefore also affect burn rates at the flame front.⁵⁰ This has been further investigated by Sjöberg et al.⁵¹ with experimentation on an HCCI engine with the main EGR components being varied. They highlight the fact that water vapour enhances the early reactions leading to hot ignition and observed that although this was seen for all fuels that they tested, it is more effective for PRFs than for gasoline and iso-octane. This evidence also suggests that the ignition promoting effect of water vapour can be seen at temperatures below that mentioned above at which H₂O will dissociate. The effect on the specific heat of the charge as a result of HC conversion to water in a catalyst would be negligible, as their specific heats are comparable when the water has been evaporated.

Implications for catalysed EGR

The evidence for the fuel consumption benefits of catalysed EGR is not conclusive, primarily due to the potential error introduced via EGR rate measurement with a catalysed source. The existing literature concerning the use of catalysed EGR does not fully address this issue and therefore cannot give a comprehensive conclusion. However, there is compelling evidence, through the consideration of the species present, that catalysed EGR can improve the knock limit at high load. Whether this increased knock limit is offset by other losses within the system is as yet unclear.

At low loads, it would not be expected that catalysed EGR would show much advantage over un-catalysed EGR due to pressure losses across the catalyst. Slower combustion rates with catalysed EGR, resulting from

the decrease in CO content and increase in CO₂, may also have implications for low-load points, where combustion stability may be affected by lower flame speeds at higher EGR rates.²⁰

The conversion in the catalyst of any components in the recirculated exhaust gases that may have resulted from incomplete combustion by equations (21)–(23) can reduce the calorific value of the in-cylinder mixture. This reduces the available energy for combustion and can therefore impact the BSFC, potentially offsetting some of the advantage of the more favourable combustion phasing afforded by the use of catalysed EGR

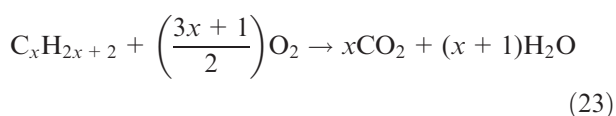
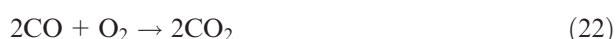

To estimate whether this could be of significance, some basic calculations have been performed using emissions and engine flow data from a 2.0-L direct injection spark ignition (DISI) engine operating at loads of 20–26 bar BMEP with an LP EGR loop and the option of using either catalysed or un-catalysed EGR.⁵² These calculations assumed that all HCs in the exhaust were composed of unburned fuel, and so exhibited the same heating value. Since NO_x measurements did not distinguish between NO and NO₂, it was assumed that all NO_x was in the form of NO (which has a higher enthalpy of combustion). The calorific proportions of the fuel and EGR components available to the cylinder are illustrated in Figure 4 for un-catalysed EGR rates of 5%, 10%, and 15% at 1500 r/min. For the typical operating points considered, with an EGR rate of 15%, the calculated reduction in total chemical energy to the inlet due to catalytic conversion of the recirculated exhaust gases reached as much as 4.5% at 1500 r/min and 2% at 3000 r/min. As can be seen in Figure 4, the NO_x contributed very little of this value (less than 0.01%) and the contribution of CO and HCs was split fairly evenly.

Importantly, the engine in question was running slightly rich in-cylinder due to valve overlaps, and

therefore, the CO and HC emissions were higher than they would be at $\lambda = 1$ conditions – which will increase the quantity of energy available in the recirculated exhaust. The EGR rates were also achieved with the use of an external EGR pump, so some parasitic losses such as pressure losses through the EGR loop were avoided and the EGR rates achieved may have been higher than reasonably expected with naturally available pressure differentials to drive it. For these reasons, the calculations are most likely an overestimate of what is reasonably expected, and so they only serve as a demonstration that the calorific value of the exhaust gases returned via EGR may also be a significant factor. The effectiveness of catalysis within the EGR loop relies heavily upon the operating regime of the engine since the temperature and composition of the exhaust gas initially entering the catalyst will strongly affect catalyst conversion efficiencies and light-off.

Although this article focuses primarily on in-cylinder effects, catalysed EGR also affects turbo-machinery operation. On the exhaust side, the turbine efficiency is sensitive to inlet temperature, mass flow, and pressure differential. The temperature is affected by the effects of EGR on combustion, and the mass flow and pressure differential are affected if the EGR routing takes exhaust gases from upstream of the turbine. Similarly, the mass flow and pressure differential affect compressor performance, which will depend on whether the EGR is routed into the inlet side pre- or post-compressor. Cruff et al.²⁸ point out that the EGR rate is limited not only by combustion stability but also by too high a mass flow through the compressor, which can choke the flow and therefore decrease compressor performance. In addition to this, EGR cooling requirements and the compressor outlet temperature limit must also be considered at high EGR rates.

Aside from the study conducted by Lewis et al.,³¹ none of the studies cited in this article considers the use of catalysed EGR at loads higher than 17 bar BMEP, but further investigation at higher loads (such as those exhibited in Lewis et al.'s³¹ study) where knock tolerance is a more prominent issue may show increased BSFC benefits with catalysed EGR. Moving forward, an investigation into the use of catalysed EGR at high

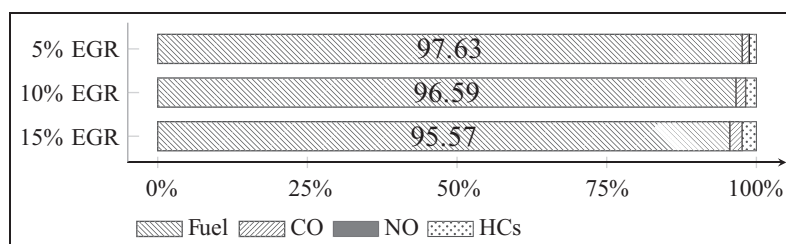

Figure 4. Representation of the proportion of energy available at the inlet from each component of the charge for 5%, 10%, and 15% un-catalysed EGR rates.

EGR: exhaust gas recirculation; HC: hydrocarbon.

Data taken from Lewis.⁵²

loads, with improved instrumentation on the catalyst and emissions' measurement, may shed light on a promising technology for knock control.

Conclusion

Conflicting evidence^{29,30} does not permit a firm conclusion on the fuel consumption benefit of catalysed EGR, although it appears to be more effective with HP EGR than with LP EGR. A reliable conclusion cannot be reached without a reliable measurement of the EGR rate that gives a true representation of the total quantity of recirculated exhaust gas within the inlet charge.

A review of the relevant combustion kinetics with additional compounds such as NO, CO, and HCs included in the inlet charge gives compelling evidence that catalysed EGR is capable of increasing the knock limit of an engine for a given EGR rate by up to 5° CA.²⁹ A large part of this can be attributed to the removal of NO, which can promote autoignition in the end gas and increase the propensity to knock.

The conversion of HCs, CO, and NO in the catalyst can, however, result in up to a 4.5% reduction (in extreme cases) in the calorific value of the charge for catalysed EGR when compared to equivalent operation with un-catalysed EGR, which has a negative impact on the achievable BSFC. The recorded impact of catalysed EGR on BSFC in the literature has ranged from a reduction of 2%³⁰ to an increase of 3.5%.²⁹

In order to further understand the mechanisms behind these figures, further investigation would be required. Some questions that should be addressed include the following:

Would higher levels of instrumentation such as catalyst inlet/outlet temperatures and detailed Fourier transform infrared (FTIR) spectroscopy exhaust gas measurements shed more light on the mechanisms involved? Does the trade-off between the extended knock limit for a given EGR mass flow and the lower calorific value of recirculated exhaust gases provide a potential benefit to engine efficiency?

If the maximum achievable EGR rate is reduced by catalysing the exhaust gases, would the extended knock limit compensate for this so that benefits are still seen? Would the extended knock limit reduce the cooling demands on the EGR loop, or would exothermic reactions involved in catalysis override this to increase cooling demands?

At higher loads, will the knock control benefit of catalysed EGR become more apparent?

Further work to clarify earlier studies on catalysed EGR could include FTIR analysis of the exhaust composition pre- and post-catalyst in the EGR loop to give further information on the different species of NO_x and HCs present; valuable information could also be obtained from the catalyst temperature to understand

the catalyst operation further. As Sjöberg et al.⁵¹ mention, in practical EGR systems, the water content of the exhaust may partially condense onto cold surfaces resulting in differences in EGR composition and potentially on its effect on combustion. Levels of cooling on EGR circuits could be altered to reflect this (with appropriate drainage of the waste water) in experimental situations to investigate the extent of this effect. The effects of the different components could then be more accurately simulated with either synthetic-EGR or by computer simulation.

Declaration of conflicting interests

The authors declare that there is no conflict of interest.

Funding

This work was supported by The Engineering and Physical Sciences Research Council.

References

1. Cairns A, Blaxill H and Irlam G. Exhaust gas recirculation for improved part and full load fuel economy in a turbocharged gasoline engine (reprinted from SI combustion and direct injection SI engine technology). SAE technical paper 2006-01-0047, 2006. DOI: 10.4271/2006-01-0047.
2. Stokes J, Lake TH and Osborne RJ. A gasoline engine concept for improved fuel economy – the lean boost system. SAE technical paper 2000-01-2902, 2000. DOI: 10.4271/2000-01-2902.
3. Turner JWG, Pearson RJ, Bassett MD and Blundell DW. The turboexpansion concept – initial dynamometer results. SAE technical paper 2005-01-1853, 2005. DOI: 10.4271/2005-01-1853.
4. Hancock D, Fraser N, Jeremy M, Sykes R and Blaxill H. A new 3 cylinder 1.2l advanced downsizing technology demonstrator engine. SAE technical paper 2008-01-0611, 2008. DOI: 10.4271/2008-01-0611.
5. Diana S, Giglio V, Iorio B and Police G. Evaluation of the effect of EGR on engine knock. SAE technical paper 982479, 1998. DOI: 10.4271/982479.
6. Mittal V, Revier BM and Heywood JB. Phenomena that determine knock onset in spark-ignition engines. SAE technical paper 2007-01-0007, 2007. DOI: 10.4271/2007-01-0007.
7. Grandin B, Denbratt I, Bood J, Brackmann C, Bengtsson P, Gogan A, et al. Heat release in the end-gas prior to knock in lean, rich and stoichiometric mixtures with and without EGR. SAE technical paper 2002-01-0239, 2002. DOI: 10.4271/2002-01-0239.
8. Hedge M, Weber P, Gingrich J, Alger T and Khalek I. Effect of EGR on particle emissions from a GDI engine. *SAE Int J Engines* 2011; 4(1): 650–666. DOI: 10.4271/2011-01-0636.
9. Ricardo HR. Paraffin as fuel. *The Automotive Engineering*, 1919; 9: 2–5.
10. Cairns A and Blaxill H. Lean boost and external exhaust gas recirculation for high load controlled auto-ignition. SAE technical paper 2005-01-3744, 2005. DOI: 10.4271/2005-01-3744.

11. Cairns A, Fraser N and Blaxill H. Pre versus post compressor supply of cooled EGR for full load fuel economy in turbocharged gasoline engines. SAE technical paper 2008-01-0425, 2008. DOI: 10.4271/2008-01-0425.
12. Alger T, Chauvet T and Dimitrova Z. Synergies between high EGR operation and GDI systems. *SAE Int J Engines* 2009; 1(1): 101–114. DOI: 10.4271/2008-01-0134.
13. Grandin B and Ångström H. Knock suppression in a turbocharged SI engine by using cooled EGR. SAE technical paper 982476, 1998. DOI: 10.4271/982476.
14. Grandin B and Ångström H. Replacing fuel enrichment in a turbo charged SI engine: lean burn or cooled EGR (reprinted from combustion and emission formation in SI engines). SAE technical paper 1999-01-3505, 1999. DOI: 10.4271/1999-01-3505.
15. Vitek O, Macek J, Polasek M, Schmerbeck S and Kammerdiener T. Comparison of different EGR solutions. SAE technical paper 2008-01-0206, 2008. DOI: 10.4271/2008-01-0206.
16. Potteau S, Lutz P, Leroux S, Moroz S and Tomas E. Cooled EGR for a turbo SI engine to reduce knocking and fuel consumption. SAE technical paper 2007-01-3978, 2007. DOI: 10.4271/2007-01-3978.
17. Turner JWG, Pearson RJ, Curtis R and Holland B. Effects of cooled EGR routing on a second-generation DISI turbocharged engine employing an integrated exhaust manifold. SAE technical paper 2009-01-1487, 2009. DOI: 10.4271/2009-01-1487.
18. Galloni E, Fontana G and Palmaccio R. Numerical analyses of EGR techniques in a turbocharged spark-ignition engine. *Appl Therm Eng* 2012; 39: 95–104.
19. Hattrell T, Sheppard CGW, Burluka AA, Neumeister J and Cairns A. Burn rate implications of alternative knock reduction strategies for turbocharged SI engines. SAE technical paper 2006-01-1110, 2006. DOI: 10.4271/2006-01-1110.
20. Fontana G and Galloni E. Experimental analysis of a spark-ignition engine using exhaust gas recycle at WOT operation. *Appl Energ* 2010; 87(7): 2187–2193.
21. Kaiser M, Krueger U, Harris R and Cruff L. Doing more with less – the fuel economy benefits of cooled EGR on a direct injected spark ignited boosted engine. SAE technical paper 2010-01-0589, 2010.
22. Bourhis G, Chauvin J, Gautrot X and De Francqueville L. LP EGR and IGR compromise on a GDI engine at middle load. *SAE Int J Engines* 2013; 6(1): 67–77. DOI: 10.4271/2013-01-0256.
23. Hoepke B, Jannsen S, Kasseris E and Cheng WK. EGR effects on boosted SI engine operation and knock integral correlation. *SAE Int J Engines* 2012; 5(2): 547–559. DOI: 10.4271/2012-01-0707.
24. Topinka JA, Gerty MD, Heywood JB and Keck JC. Knock behavior of a lean-burn, H₂ and CO enhanced, SI gasoline engine concept. SAE technical paper 2004-01-0975, 2004. DOI: 10.4271/2004-01-0975.
25. Tang X, Kabat DM, Natkin RJ, Stockhausen WF and Heffel J. Ford P2000 hydrogen engine dynamometer development. SAE technical paper 2002-01-0242, 2002. DOI: 10.4271/2002-01-0242.
26. Fennell D, Herreros JM, Tsolakis A, Xu H, Cockle K and Millington P. GDI engine performance and emissions with reformed exhaust gas recirculation (REGR). SAE technical paper 2013-01-0537, 2013. DOI: 10.4271/2013-01-0537.
27. Cairns A, Todd A, Hoffman H, Aleiferis P and Malcolm J. Combining unthrottled operation with internal EGR under port and central direct fuel injection conditions in a single cylinder SI engine. SAE technical paper 2009-01-1835, 2009. DOI: 10.4271/2009-01-1835.
28. Cruff L, Kaiser M, Krause S, Harris R and Williams M. EBDI – application of a fully flexible high BMEP downsized spark ignited engine. SAE technical paper 2010-01-0587, 2010. DOI: 10.4271/2010-01-0587.
29. Roth DB, Keller P and Becker M. Requirements of external EGR systems for dual cam phaser turbo GDI engines. SAE technical paper 2010-01-0588, 2010. DOI: 10.4271/2010-01-0588.
30. Hoffmeyer H, Montefrancesco E, Beck L, Willand J, Ziebart F and Mauss F. CARE – catalytic reformed exhaust gases in turbocharged DISI-engines. *SAE Int J Fuels Lubr* 2009; 2(1): 139–148. DOI: 10.4271/2009-01-0503.
31. Lewis A, Akehurst S, Turner J, Patel R and Popplewell A. Observations on the measurement and performance impact of catalyzed vs. non catalyzed EGR on a heavily downsized DISI engine. *SAE Int J Engines* 2014; 7(1): 458–467. DOI: 10.4271/2014-01-1196.
32. Burluka AA, Liu K, Sheppard CGW, Smallbone AJ and Woolley R. The influence of simulated residual and NO concentrations on knock onset for PRFs and gasolines (reprinted from SI engine experiment and modeling). SAE technical paper 2004-01-2998, 2004. DOI: 10.4271/2004-01-2998.
33. Stenlaas O, Gogan A, Egnell R and Sunden B. The influence of nitric oxide on the occurrence of autoignition in the end gas of spark ignition engines. SAE technical paper 2002-01-2699, 2002. DOI: 10.4271/2002-01-2699.
34. Kawabata Y, Sakonji T and Amano T. The effect of NO_x on knock in spark-ignition engines. SAE technical paper 1999-01-0572, 1999. DOI: 10.4271/1999-01-0572.
35. Stenlaas O, Einewall P, Egnell R and Johansson B. Measurement of knock and ion current in a spark ignition engine with and without NO addition to the intake air (reprinted from SI combustion). SAE technical paper 2003-01-0639, 2003. DOI: 10.4271/2003-01-0639.
36. Prabhu SK, Li H, Miller DL and Cernansky NP. The effect of nitric oxide on autoignition of a primary reference fuel blend in a motored engine. SAE technical paper 932757, 1993. DOI: 10.4271/932757.
37. Risberg P, Johansson D, Andrae J, Kalghatgi G, Bjornbom P and Ångström H. The influence of NO on the combustion phasing in an HCCI engine. SAE technical paper 2006-01-0416, 2006. DOI: 10.4271/2006-01-0416.
38. Dubreuil A, Foucher F and Mounaim-Rousselle C. Effect of EGR chemical components and intake temperature on HCCI combustion development. SAE technical paper 2006-32-0044, 2006. DOI: 10.4271/2006-32-0044.
39. Roberts PJ and Sheppard CGW. The influence of residual gas NO content on knock onset of iso-octane, PRF, TRF and ULG mixtures in SI engines. *SAE Int J Engines* 2013; 6(4): 2028–2043. DOI: 10.4271/2013-01-9046.
40. Naik CV, Puduppakkam K and Meeks E. Modeling the detailed chemical kinetics of NO_x sensitization for the oxidation of a model fuel for gasoline. *SAE Int J Fuels Lubr* 2010; 3(1): 556–566. DOI: 10.4271/2010-01-1084.
41. Faravelli T, Frassoldati A and Ranzi E. Kinetic modeling of the interactions between NO and hydrocarbons in the

- oxidation of hydrocarbons at low temperatures. *Combust Flame* 2003; 132: 188–207.
42. Hori M, Koshiishi Y, Matsunaga N, Glaude P and Marinov N. Temperature dependence of NO to NO₂ conversion by n-butane and n-pentane oxidation. *Proc Combust Inst* 2002; 29(2): 2219–2226.
 43. Towers JM and Hoekstra RL. Engine knock, a renewed concern in motorsports – a literature review. SAE technical paper 983026, 1998. DOI: 10.4271/983026.
 44. Fieweger K, Blumenthal R and Adomeit G. Self-ignition of S.I. engine model fuels: a shock tube investigation at high pressure. *Combust Flame* 1997; 109(4): 599–619.
 45. Westbrook CK. Chemical kinetics of hydrocarbon ignition in practical combustion systems. *Proc Combust Inst* 2000; 28: 1563–1577.
 46. Warnatz J, Maas U and Dibble RW. *Combustion: physical and chemical fundamentals, modelling and simulation, experiments, pollutant formation*. 4th ed. Berlin/Heidelberg: Springer, 2006.
 47. Eng JA, Leppard WR, Najt PM and Dryer FL. The interaction between nitric oxide and hydrocarbon oxidation chemistry in a spark ignition engine. SAE technical paper 972889, 1997. DOI: 10.4271/972889.
 48. Heywood JB. *Internal combustion engine fundamentals*. New York: McGraw-Hill, 1988.
 49. Boretta A. Water injection in directly injected turbocharged spark ignition engines. *Appl Therm Eng* 2013; 52(1): 62–68.
 50. Kwon H and Min K. Laminar flame speed characteristics and combustion simulation of synthetic gas fueled SI engine. SAE technical paper 2008-01-0965, 2008. DOI: 10.4271/2008-01-0965.
 51. Sjöberg M, Dec JE and Hwang W. Thermodynamic and chemical effects of EGR and its constituents on HCCI autoignition. SAE technical paper 2007-01-0207, 2007. DOI: 10.4271/2007-01-0207.
 52. Lewis A. *Data from ultraboost engine*. Bath: University of Bath, 2013.