



Citation for published version:

Bowen, CR, Taylor, J, Leboulbar, E, Zabek, D, Chauhan, A & Vaish, R 2014, 'Pyroelectric materials and devices for energy harvesting applications', *Energy & Environmental Science*, vol. 7, no. 12, pp. 3836-3856.
<https://doi.org/10.1039/c4ee01759e>

DOI:

[10.1039/c4ee01759e](https://doi.org/10.1039/c4ee01759e)

Publication date:

2014

Document Version

Early version, also known as pre-print

[Link to publication](#)

University of Bath

General rights

Copyright and moral rights for the publications made accessible in the public portal are retained by the authors and/or other copyright owners and it is a condition of accessing publications that users recognise and abide by the legal requirements associated with these rights.

Take down policy

If you believe that this document breaches copyright please contact us providing details, and we will remove access to the work immediately and investigate your claim.

Pyroelectric materials and devices for energy harvesting applications

C.R.Bowen¹, J. Taylor², E. LeBoulbar^{1,2}, D. Zabek¹, A. Chauhan³, R. Vaish³

¹ Department of Mechanical Engineering, University of Bath, Bath, BA2 7AY, United Kingdom

² Department of Electrical and Electronic Engineering, University of Bath, Bath, BA2 7AY, United Kingdom

³ School of Engineering, Indian Institute of Technology Mandi, 175 001, Himachal Pradesh, India

Abstract

This review covers energy harvesting technologies associated with pyroelectric materials and systems. Such materials have the potential to generate electrical power from thermal fluctuations and is a less well explored form of thermal energy harvesting than thermoelectric systems. The pyroelectric effect and potential thermal and electric field cycles for energy harvesting are explored. Materials of interest are discussed and pyroelectric architectures and systems that can be employed to improve device performance, such as frequency and power level, are described. In addition to the **solid materials** employed, the appropriate pyroelectric harvesting circuits to condition and store the electrical power are discussed.

Table of Contents Entry

Solid pyroelectric materials and systems have the potential to generate electrical power from thermal fluctuations and is a less explored form of thermal harvesting.

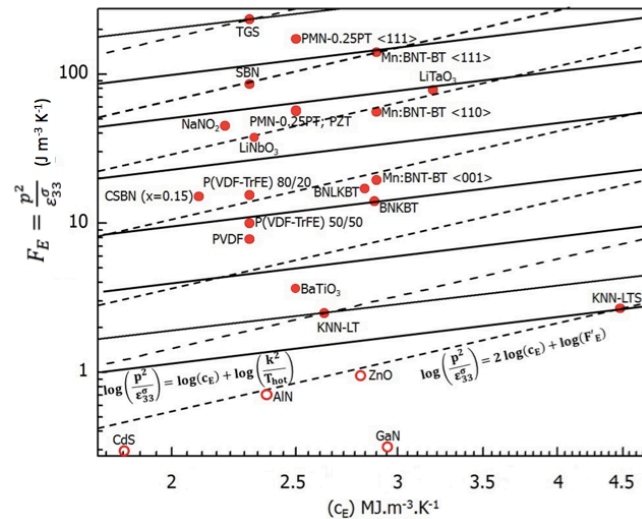

Brief paragraph

Energy harvesting of a variety of sources such as mechanical vibrations, heat and light remains a topic of intense academic and commercial interest. While thermoelectric materials are capable of generating electrical energy from a temperature gradient, pyroelectric materials and systems can generate electrical power from thermal fluctuations. Solid pyroelectric materials, modes of operation, harvesting circuits and the range of pyroelectric harvesting systems are discussed.

1. Introduction

Energy harvesting is currently a topic of intense interest as a result of the growing energy demands of society and as a means to create autonomous and self-powered systems. For example, applications for energy harvesting devices include battery-free wireless sensor networks that do not require maintenance or replacement, with typical power requirements in the μm with mW range [1]. Methods to scavenge 'local' energy sources to generate electrical power has been considered by many researchers; examples include the use of piezoelectric materials and electromagnetic systems to convert mechanical motion into electrical energy. Other forms of ambient energy sources

include (i) light, where photo-voltaics and water-splitting are being considered, (ii) wind, including the creation of micro-turbines and (iii) harvesting electromagnetic waves using antennas.

In the context of thermal energy harvesting, heat remains an almost ubiquitous and abundant ambient source of energy that is often wasted as low-grade waste heat [2]. Thermoelectrics have been widely used and considered as a means to convert temperature gradients into electrical energy using the *Seebeck* effect. A less widely researched area is 'pyroelectric energy harvesting' [3] in which temperature fluctuations are converted into electrical energy; although the potential to convert thermal energy to electrical energy using ferroelectric materials has been considered in the 1960's and 1970's [4] [5] [6] [7] [8] [9] [10].

This review provides an introduction to current and past research on pyroelectric energy harvesting materials and systems. A number of excellent introductions to pyroelectric materials already exist, most of which concentrate on their use for heat-sensing, infra-red detection, thermal imaging, fire alarms, gas analysers and pollution monitors [11] [12] [13] [14] [15]. Lang has also provided a historical review of pyroelectrics [16] and Lubomirsky et al. reviewed in detail the methods of pyroelectric measurement [17]. In the context of pyroelectric harvesting, Lingham et al. provided a recent review with an emphasis on nano- and micro-scale systems [18] and Hunter et al. [2] provided a history of pyroelectric related harvesting [2]; there is also a recent book on the topic waste energy harvesting including both mechanical and thermal energies [19]. This review will describe the concept of pyroelectricity and the methods by which energy can be derived from temperature fluctuations. A comparison with piezoelectric vibration energy harvesters will be made since all pyroelectric materials are also piezoelectric. Potential materials and relevant figures of merit for the selection of appropriate pyroelectric materials for energy harvesting will be discussed. While pyroelectric materials form the basis of the harvesting device there is a need to condition and store the power generated by the material and the types of electrical circuits employed for harvesting will be summarised. Finally, examples of novel pyroelectric systems from macro- to nano-scale will be described. **This review will focus on papers specifically related to energy harvesting and the majority of the materials employed to date are in solid form; liquid crystals [20] and molecular ferroelectrics [21] are not covered in this review although it would be of interest in the future to consider the applicability of these materials for harvesting applications.**

A significant amount of waste heat is lost as a by-product of power, refrigeration, or heat pump cycles [22] and it has been reported that in 2009 half of the energy consumed in the United States was wasted as low-grade waste heat [23] [24]. To harvest waste heat thermoelectric materials have attracted interest, with a number of commercial supplies of thermo-electric generators (TEGs) [25]

[26]. Thermoelectric materials and systems generate electrical power from temperature gradients (dT/dx) while pyroelectric materials produce power from temperature fluctuations (dT/dt) [27] and have some similarities to the way in which piezoelectric harvesters convert mechanical oscillations ($d\alpha/dt$) into electricity [28]. Pyroelectric materials are of interest since under the correct conditions they have the potential to operate with a high thermodynamic efficiency and, compared to thermoelectrics, do not require bulky heat sinks to maintain a temperature gradient [29]. We will see in this review that pyroelectric harvesters tend to operate at low frequency, typically $<1\text{Hz}$ [30], due to the slow temperature oscillations in systems of large thermal mass and heat transfer inertia. Since temperature oscillations are often slow, efforts to transform a temperature gradient into a time variable temperature include the use of cyclic pumping [31]. The power consumed by the pumping process can be a relatively small fraction of the harvested energy ($<2\%$), which can make the process feasible [31] [32] [33]. Naturally occurring temperature changes for harvesting are rare but examples include changes in ambient temperature, the human body [34], exhaust gases and natural temperature variations [35] due to convection and solar energy [36].

2. The pyroelectric effect

All pyroelectrics are polar materials and exhibit a spontaneous polarization P_s in the absence of an applied electric field [12]. Examples of polarisation include that of ionically bonded materials whereby the polarisation can be a consequence of the crystal structure, while in crystalline polymers with aligned molecular chains it can be due to the alignment of polarised covalent bonds [11]. The presence of a spontaneous polarisation in the material leads to the presence of a charge on each surface of the material and free charges, such as ions or electrons, are attracted to the charged surfaces of the material. The origin of pyroelectric behaviour is understood from the behaviour of the surface charge as the ambient temperature is changed and assuming that the polarisation level is dependent on material temperature [12].

If a pyroelectric is heated ($dT/dt > 0$) there is a decrease in its level of spontaneous polarisation as dipoles within the material lose their orientation due to thermal vibrations, see Figure 1. This fall in the polarisation level leads to a decrease in the number of free charges bound to the material surface [12]. If the material is under open circuit conditions the free charges remain at the electrode surface and an electric potential is generated across the material [18]. If the material is under short circuit conditions an electric current flows between the two polar surfaces of the material. Similarly, if the pyroelectric is cooled ($dT/dt < 0$) the dipoles regain their orientation leading to an increase in

the level of spontaneous polarization, thus reversing the electric current flow under short circuit conditions as free charges are attracted to the polar surfaces.

Equation 1 defines the relationship between pyroelectric charge (Q), generated current (i_p), rate of temperature change (dT/dt), surface area of the material (A) and *pyroelectric coefficient* (p) [36] under short circuit conditions with electrodes that are orientated normal to the polar direction.

$$i_p = \frac{dQ}{dt} = p \cdot A \cdot \frac{dT}{dt} \quad (\text{Eqn. 1})$$

The *pyroelectric coefficient* of an unclamped material, under a constant stress and electric field, is defined by Equation 2,

$$p^{\sigma,E} = \left(\frac{dP_s}{dT} \right)_{\sigma,E} \quad (\text{Eqn. 2})$$

where P_s is spontaneous polarisation [37] and subscripts σ and E correspond to conditions of constant stress and electric field respectively. While the pyroelectric coefficient is a vector quantity, the electrodes that collect the charges are often normal to the polar direction and so the measured quantity is often treated as a scalar [14]. The ability of small changes in temperature to produce a pyroelectric current has been exploited for infra-red imaging and motion detection by body heat [12]. This small electric current can also be considered for energy harvesting applications.

To maximise the pyroelectric current under short-circuit conditions, clearly the pyroelectric should have a large surface area, large pyroelectric coefficient and a high rate of temperature change. Equation 1 implies that the generated current (but not necessarily power) is independent of thickness and proportional to area since the current is simply associated with the surface charge, an observation made by Gauguin in 1859 [14].

Since there is a requirement for a pyroelectric material to be polar and exhibit a level of polarisation all pyroelectric materials are *piezoelectric* (pyroelectrics are a sub-class of piezoelectric materials so that all pyroelectrics are piezoelectric). However, not all piezoelectrics are pyroelectric since materials such as quartz only become polarised as a result of a mechanical stress. In '*ferroelectric*' pyroelectric materials the orientation, and sign, of the spontaneous polarisation can be switched by reversing the direction of the applied electric field. These ferroelectrics are a sub-class of pyroelectric materials so that all ferroelectrics are both pyroelectric and piezoelectric. **Table 1** highlights some common pyroelectric materials which will be described in more detail later in the review. In general, ferroelectric materials have larger pyroelectric and piezoelectric coefficients

compared to non-ferroelectrics; however if a ferroelectric is heated beyond the Curie temperature (T_c) it undergoes a phase transition where the spontaneous polarization and both the pyroelectric and piezoelectric behaviour vanish.

Figure 1 shows an example of the decrease of the spontaneous polarisation of a ferroelectric with increasing temperature and the corresponding pyroelectric coefficient (dP_s/dT) which decreases to zero at the Curie temperature (T_c) where the material is no longer pyroelectric. The pyroelectric coefficient rises significantly as the material begins to rapidly lose its polarisation as it approaches T_c . While the loss of piezoelectric properties above the Curie temperature is a disadvantage for vibration harvesters, the phase transition at the Curie temperature has attracted some interest for pyroelectric harvesting since the material has the potential to discharge a large amount of electrical energy as the level of polarisation falls to zero [38]. An obvious complexity of thermally cycling above and below the Curie temperature is the need to re-polarise the ferroelectric on cooling below T_c ; this is usually achieved by the application of an electric field.

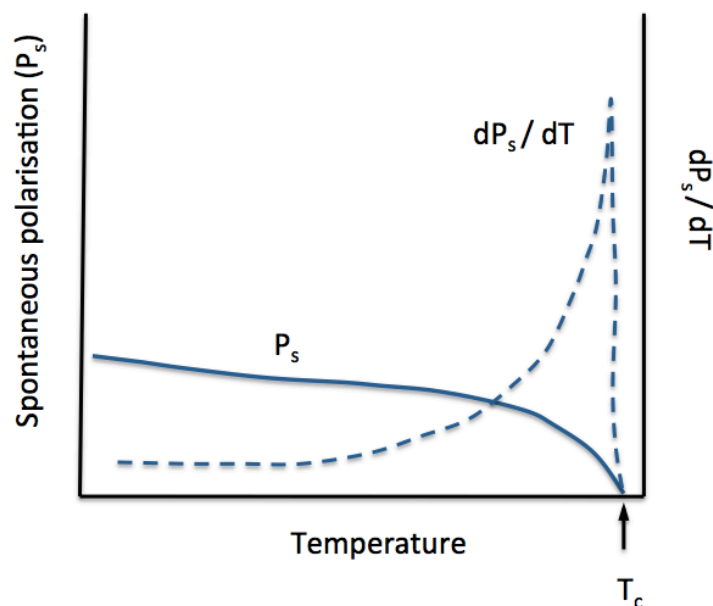

Figure 1. Temperature dependence of spontaneous polarisation P_s and pyroelectric coefficient dP_s/dT ferroelectric material, adapted from [14].

2.1 Primary, secondary and tertiary pyroelectric coefficients

As discussed, a temperature change alters the degree of polarisation and leads to an electric current. The *primary* pyroelectric effect is relevant to the condition of a perfectly clamped material under constant strain [12] with a homogenous heat distribution without an external field bias. In many cases of measurement and energy harvesting a *secondary* pyroelectric effect is present since thermal expansion induces a strain that alters the electric displacement via the piezoelectric effect;

the complexity of separating pyroelectric and piezoelectric responses has been well documented by Lubmirsky et al. [17]. Using tensor notation the primary pyroelectric coefficient at constant strain (p^x), i.e. in the clamped condition, is related to the pyroelectric coefficient at constant stress (p^σ) by Equation 3 [14] [11] [39] [40]:

$$p^{\sigma,E} = p^{x,E} + d_{ij} \cdot c_{ij}^E \cdot \alpha_i^E \quad (\text{Eqn. 3})$$

where d_{ij} are the piezoelectric coefficients, c_{ij} are elastic constants and α the thermal expansion coefficient; the subscript x corresponds to the conditions of constant strain. The term $d_{ij} \cdot c_{ij}^E \cdot \alpha_i^E$ is called the *secondary pyroelectric coefficient* and while it can be small in ferroelectrics [11] it can make a significant contribution to the overall pyroelectric coefficient. **As a result, measurements of pyroelectric coefficients must be under taken under specific conditions while in energy harvesting applications temperature, frequency, electrical and mechanical boundary conditions may be less precise or even vary with time.** It is therefore important to define the mechanical and electrical boundary conditions of harvesters [19]. Data for a variety of pyroelectrics has been collected in an excellent review by Li *et al.* [39] and **Table 1** includes both the primary and secondary pyroelectric coefficient for some common materials as examples. For thin-film materials substrate clamping can reduce the pyroelectric response to a small value compared to its unclamped value, e.g. in the case of CdS and ZnO [40]. This may be a potential advantage of replacing thin films with a nano-rod geometry that is less likely to suffer from substrate clamping; nano-scale pyroelectric materials will be described later in the review [41]. Whatmore [11] also described an interesting condition where the secondary effect can be important if the material is subjected to an alternating heat flux whose frequency matches the mechanical resonance frequency; this has not been considered for energy harvesting applications.

Coupling a pyroelectric to an external structure which undergoes large thermal deformations is also a potential approach to enhance harvested energy. Chang *et al.* [42] examined laminate structures with differing thermal expansion and stiffness characteristics to enhance the contribution of the secondary pyroelectric coefficient for energy harvesting, with significant improvement in overall pyroelectric coefficient depending on the thickness ratios of the individual layers [43]. Lim described a cantilever where the thermal expansion mismatch between a pyroelectric and thin film was used to generate energy [44].

Tertiary pyroelectricity, due to non-uniform heating is also possible since non-uniform heating generates shear stresses that result in polarization through the piezoelectric effect [12]. In this case the current generated is dependent on the magnitude of the temperature gradient [11]. Secondary and tertiary effects are therefore potential routes for enhancing thermal harvesting along with heat transfer enhancement or materials selection or development, which will now be described.

3. Pyroelectric materials

For an unclamped pyroelectric material, the expressions for charge and voltage generated and energy stored in a pyroelectric material can be derived as follows. From Equation 1, the pyroelectric current is independent of material thickness and only depends on the effective area of the electrode. By integrating Equation 1 with respect to time, the net charge developed due to a temperature change (ΔT) is;

$$Q = p \cdot A \cdot \Delta T \quad (\text{Eqn. 4})$$

As pyroelectric materials are typically dielectric in nature, the equivalent capacitance (C) is given by;

$$C = \frac{A \cdot \epsilon_{33}^{\sigma}}{h} \quad (\text{Eqn. 5})$$

where ϵ_{33}^{σ} is the permittivity in the polarisation direction at constant stress. The open circuit voltage (V) and electric field (E_{field}) developed across the electrodes, from $Q=C \cdot V$, can be expressed as:

$$V = \frac{p}{\epsilon_{33}^{\sigma}} \cdot h \cdot \Delta T \quad (\text{Eqn. 6})$$

$$E_{field} = \frac{p}{\epsilon_{33}^{\sigma}} \cdot \Delta T \quad (\text{Eqn. 7})$$

It can be seen from Equation 6 that the voltage developed across the electrodes is influenced by the thickness of the material (h) and is invariant with respect to the area of the electrodes. Since the total energy (E) stored in a capacitor is $\frac{1}{2} \cdot C \cdot V^2$, this represents the amount of energy stored in the material at the end of the temperature change and is expressed as:

$$E = \frac{1}{2} \cdot \frac{p^2}{\epsilon_{33}^{\sigma}} \cdot A \cdot h \cdot (\Delta T)^2 \quad (\text{Eqn. 8})$$

3.1 Pyroelectric Energy Harvesting Figures of Merits

A variety of figures of merit (FOMs) have been derived for materials selection based on consideration of the thermal and electrical circuits employed [11]. The most common are based on a

pyroelectric sensor application for the generation of maximum current or voltage for a given power input [14]. For infra-red detection devices based on current responsivity (F_i) [14], to maximise the pyroelectric current generated for a given energy input the FOM is:

$$F_i = \frac{p}{c_E} = \frac{p}{\rho c_p} \quad (\text{Eqn. 9})$$

where c_p is the specific heat capacity ($\text{J kg}^{-1} \text{K}^{-1}$), ρ is the density (kg m^{-3}) and c_E is the volume specific heat ($\text{J m}^{-3} \text{K}^{-1}$). For a high voltage responsivity (F_v) [14] to maximize pyroelectric voltage for an energy input the FOM is:

$$F_v = \frac{p}{c_E \epsilon_{33}^\sigma} = \frac{p}{\rho c_p \epsilon_{33}^\sigma} \quad (\text{Eqn. 10})$$

The F_i and F_v FOMs are often used for selection of materials for heat and infra-red detection, but these are not to be confused with energy harvesting applications where generated energy or power is a key criterion as well as the overall efficiency of the conversion of thermal energy to electrical energy.

For energy harvesting applications two pyroelectric based FOMs have been proposed to date [45] [46]. An electro-thermal coupling factor has been defined to estimate the effectiveness of thermal harvesting [45]:

$$k^2 = \frac{p^2 T_{hot}}{c_E \epsilon_{33}^\sigma} = \frac{p^2 T_{hot}}{\rho c_p \epsilon_{33}^\sigma} \quad (\text{Eqn. 11})$$

where T_{hot} is the maximum working temperature. This FOM has a direct influence on the efficiency and electrical work obtained during cyclic temperature oscillation cycles, which will be described later. For many materials the value is low (<1%) and examples are shown in Table 1. An energy harvesting FOM, F_E , has also been proposed as [46]:

$$F_E = \frac{p^2}{\epsilon_{33}^\sigma} \quad (\text{Eqn. 12})$$

The energy harvesting FOM, F_E , has been widely used for materials selection and materials design [38] [47] [48] [49] [50] for pyroelectric harvesting applications. Compared to the voltage (F_v) and current (F_i) responsivity the harvesting FOM, F_E , does not include the heat capacity. It is worth noting that the static definitions of the FOMs do not take into account the transient nature of heat transfer and dielectric losses; FOMs that include dielectric loss and diffusivity have been defined for pyroelectric sensing [11] and may be of interest to adapt for harvesting applications.

An alternative pyroelectric harvesting FOM that includes the influence of heat capacity can be derived from Eqn. 8. The relationship between input *enthalpy* (H) and resulting temperature change (ΔT) is $H = A \cdot h \cdot c_E \cdot \Delta T$; substituting this into Eqn. 8 provides an F'_E energy harvesting FOM.

$$F'_E = \frac{p^2}{\epsilon_{33}^{\sigma} (c_E)^2} \quad (\text{Eqn. 13})$$

A higher value of F'_E implies that a larger amount of energy is converted by the material for a given enthalpy input.

3.2 Pyroelectric materials and selection for energy harvesting

Their properties and calculated FOMs are given in Table 1 for a variety of pyroelectric materials, including both ferroelectric and non-ferroelectric material. It can be observed from Table 1 that triglycine sulphide (TGS) is potentially an excellent material for pyroelectric energy conversion purposes. TGS has the chemical composition of $(\text{NH}_2\text{CH}_2\text{COOH})_3\text{H}_2\text{SO}_4$ and crystals based on the glycine group ($\text{NH}_2\text{CH}_2\text{COOH}$) are polar and exhibit very high pyroelectric FOMs [11]. Despite its high performance, TGS has attracted limited interest for harvesting applications, possibly due to its low Curie temperature of 49°C [51]. It is also water soluble, hygroscopic and relatively low strength.

Lead magnesium niobate – lead titanate (PMN-PT) single crystals are relatively new materials that are being explored for a number of transducer applications. The $(1-x)\text{Pb}(\text{Mg}_{1/3}\text{Nb}_{2/3})\text{O}_3-x\text{PbTiO}_3$ (1-xPMN-xPT) system is a family of relaxor based ferroelectric compositions which are of interest for transducer devices due to their ultra-high piezoelectric and pyroelectric coefficients. The morphological phase boundary (MPB) for PMN-xPT spans from ($x=$) 30 to 38 mol. % and this range is characterised by a monoclinic phase in co-existence with a rhombohedral (up to 32 mol.%) or tetragonal phase (32 to 38 mol. %) [52]. These crystals have a relatively low Curie temperature (121°C); while this can limit the material to relatively low temperature operation it is useful to remember that the pyroelectric coefficient rises near T_c , figure 1. Due to their single crystal nature, the materials are relatively expensive and can be formed in limited shapes [53]. The high FOM and range of phase transitions associated with these materials have to led interest in this material for a number of pyroelectric harvesting applications [46] [54] [36] [55] [56] [57].

The lead zirconate titanate (PZT) family remains a widely used commercial ceramic due to its relative ease of fabrication in polycrystalline form and good piezoelectric properties, with a range of ‘hard’ and ‘soft’ composition with tailored properties. This family of material has therefore attracted interest for pyroelectric harvesting applications [58] [59] [37] [36] [60] [61] [62] [63] [64] [65] [66] [67]. Improved pyroelectric properties were recently reported in compositionally graded

$\text{PbZr}_{1-x}\text{Ti}_x\text{O}_3$, including high pyroelectric harvesting FOM by Mangalam et al. [47]. Lanthanum doped PZT relaxor-ferroelectrics have also been used for harvesting applications where doping increases resistivity and coupling coefficients [68] [69] [70].

Lead-free materials are of interest for environmental and health concerns and manganese doped bismuth sodium titanate- barium titanate (BNT-BT) single crystal is a potential pyroelectric energy harvesting material. They have been examined for harvesting at a theoretical level [71] since the compositions possess excellent piezoelectric and pyroelectric coefficients and high Curie temperatures ($T_C > 200^\circ\text{C}$) [72]. BNT based ceramics can be difficult to pole due to their high electrical conductivities and dielectric loss and to overcome these shortcomings they are often doped. For example the composition Mn:BNT-BT is a $94.6\text{Bi}_{0.5}\text{Na}_{0.5}\text{TiO}_3-5.4\text{BaTiO}_3$ single crystal doped with Mn and the $\langle 111 \rangle$ orientation of this crystal possesses the highest pyroelectric coefficient and figure of merit of lead-free ferroelectric materials [73]. In addition to BNT, $\text{Ba}_{0.65}\text{Sr}_{0.35}\text{TiO}_3$ (BST) thin films have also been examined specifically for improved energy harvesting FOMs [74].

Lithium tantalate (LiTaO_3 , LTO) single crystal is a commercially important optical and ferroelectric material and has been explored for pyroelectric applications. LiTaO_3 is thermally stable with a high Curie temperature of 665°C . Although it possesses a FOMs lower than TGS, it finds a wider range of applications owing to its low dielectric loss and thermal and physical stability. LiTaO_3 has been combined with cement for pyroelectric harvesting from pavements [75] and has even been used to generate large potential differences for the generation of ion beams for nuclear fusion studies [76]. For high temperature applications, LiNbO_3 is also of interest due to its high Curie temperature (1210°C) [77].

A family of potassium sodium niobate based materials, $(\text{K}_{0.5}\text{Na}_{0.5})\text{NbO}_3$ (KNN), was recently discovered as a high performance substitute for lead-based piezoelectric materials [78]. It has been reported to have piezoelectric performance approaching commercially available lead-based materials such as PZT and PMN-PT ceramics. The KNN-LT $\{[(\text{K}_{0.5}\text{Na}_{0.5})_{0.96}\text{Li}_{0.04}](\text{Nb}_{0.8}\text{Ta}_{0.2})\text{O}_3\}$ and KNN-LTS $\{[(\text{K}_{0.5}\text{Na}_{0.5})_{0.96}\text{Li}_{0.04}](\text{Nb}_{0.84}\text{Ta}_{0.1}\text{Sb}_{0.06})\text{O}_3\}$ compositions have improved characteristics compared to pure KNN [79] [80]. Nano-scale KNbO_3 has been considered for pyroelectric harvesting [81].

Non-ferroelectric pyroelectrics include the wurtzite based materials such as AlN, GaN, CdS and ZnO which have relatively low pyroelectric coefficients compared to the ferroelectric materials (Table 1). Since these materials are not ferroelectric they are often used in single crystal form, such as epitaxially grown films [18], or as highly orientated structures to achieve the desired polarisation. The manufacture of nanostructured materials, such as [41] ZnO nanowires, will be discussed later. These materials do, however, exhibit higher thermal conductivities compared to the ferroelectric

materials (see [Table 1](#)) allowing a more rapid change in temperature due to changes in ambient temperature.

The materials above are typically ceramic-like and are therefore relatively high density, high stiffness and brittle. If mechanical flexibility and toughness is desirable a polymeric pyroelectric material can be considered for energy harvesting, such as polyvinylidene-difluoride trifluoro-ethane P(VDF-TrFE). The basic PVDF composition has three main phases [α , β and γ] based on the trans (T) and gauche (G) chain conformations. The β phase of PVDF has ferroelectric properties owing to a crystalline structure obtained by an all trans-arrangement of the polymer chains that gives rise to a permanent dipole that can produce pyroelectric effects. The polarization is reversible owing to the rotating bonds along the polymer chains. Pure PVDF has a poorer performance compared to P(VDF-TrFE); examples of the properties and FOM for PVDF based materials are shown in [Table 1](#). PVDF based materials have attracted interest for **pyroelectric** harvesting [38] [50] [82] [83] [84] [85] [86] [37] [29] [85] [87] and their advantage is that they can be readily produced in thin film form (for improved heat transfer), are low cost, flexible, are chemically resistant and have high breakdown fields. The material is limited to relatively low temperatures ($\sim 80^{\circ}\text{C}$). Porous forms of PVDF have been examined to optimise its performance for energy harvesting [50], for example the introduction of porosity can reduce both the permittivity of the material and the heat capacity, which is clearly beneficial for some **FOMs**.

Composite materials are also attracting interest in an effort to combine high-activity ceramic ferroelectrics with a flexible and low permittivity matrix [45]; these have been examined for pyroelectric detectors but the 'composite' approach certainly offer avenues for creating interesting materials for harvesting applications [14] [88].

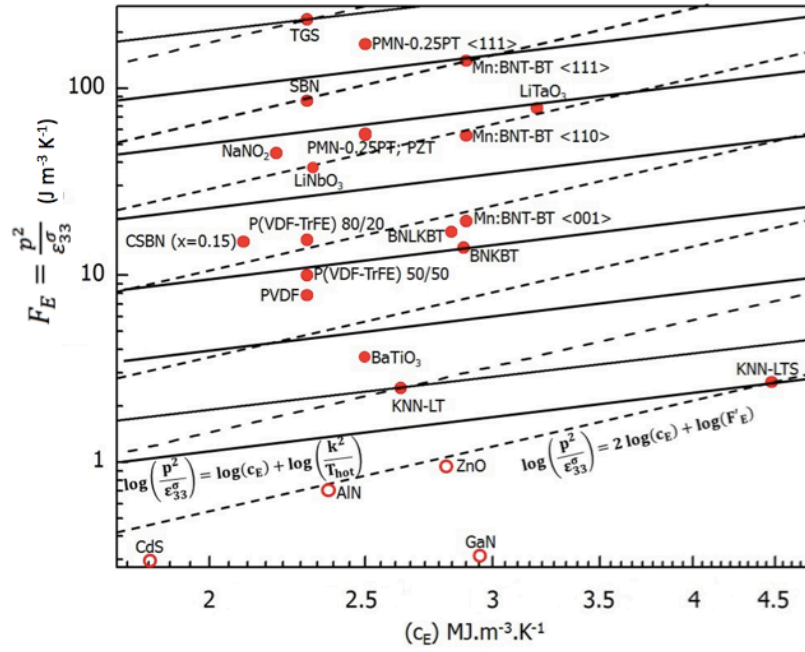

(a)

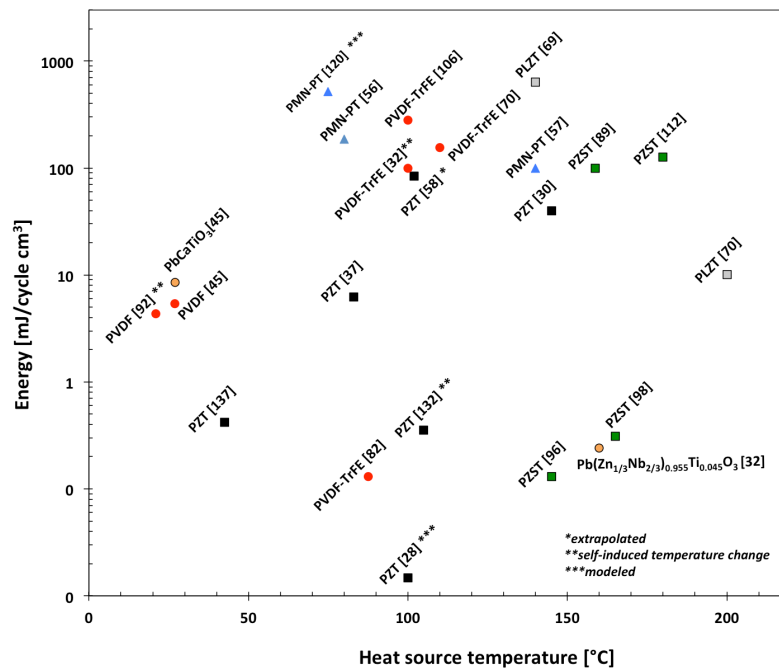

(b)

Figure 2. (a) Ashby diagram for relevant materials properties. Ferroelectric indicated by solid circles and non-ferroelectric are open-circles. (b) Examples of heat source temperatures and harvested energy for a variety of materials.

The Ashby method can be used to graphically represent the performance of pyroelectric materials. In **Figure 2a** the axes of the Ashby chart are specifically chosen so that a line may represent different FOMs. We have selected the harvesting FOM (F_E), coupling coefficient (k^2) and alternative harvesting FOM (F'_E) for a comparative analysis of materials. Since the F_E FOM is simply the y-axis, materials that are higher on the y-axis exhibit a higher F_E ; it is clear that TGS and single crystal PMN-0.25PT<111> exhibit high values. It is possible to rearrange the coupling coefficient, k^2 (**Eqn. 11**) to form an equation for a straight line ($y=mx+c$), where m is the gradient of the line, by taking logs of each side to $\log\left(\frac{p^2}{\epsilon_{33}}\right) = \log(c_E) + \log\left(\frac{k^2}{T_{hot}}\right)$. This is represented by the dashed line on **Figure 2a** with a gradient of unity ($m=1$). Materials which lie on the same line have an equal performance with respect to k^2 , those above the line have a higher k^2 . For the alternative energy FOM, F'_E , it is possible to rearrange the terms to $\log\left(\frac{p^2}{\epsilon_{33}}\right) = 2 \log(c_E) + \log(F'_E)$ which is indicated by the dotted line with a gradient of two. **Figure 2a** indicates that the best performing materials for F'_E are TGS followed by PMN-25PT <111>, Mn:BNT-BT <111>, SBN, LiTaO₃, PMN-25PT ceramic, PZT ceramic and Mn:BNT-BT <111> respectively. From the lead-free materials, co-polymers of PVDF and BNT based bulk ceramics have better performance compared to the KNN family. The non-ferroelectric pyroelectric materials (e.g. ZnO, GaN, AlN) have lower FOMs compared to the ferroelectrics (**Figure 2a** and **Table 1**).

The FOMs do not include information regarding the operating temperature which, for ferroelectrics, is often related to the Curie temperature (**Table 1**). **Figure 2b** shows examples of source temperatures for harvesting and energy generated; polymer based PVDF materials are generally at lower temperatures (<100°C) compared to the ferroelectric ceramics where the doped PZT family are of interest for higher temperatures.

4. Pyroelectric cycles for energy harvesting

A variety of thermal cycles exist [89] [90] for pyroelectric harvesting and the following is an overview of the different approaches and will be followed by a discussion of potential electrical circuits to implement such cycles. These pyroelectric cycles have been examined in detail by Sebald et al. [90].

4.1 Carnot Cycle

Figure 3a shows the polarisation-electric field plot of a Carnot cycle which has two adiabatic (Path 1-2, Path 3-4) and two isothermal processes (Path 2-3, Path 4-1) [89]. The first adiabatic process is the increase in electric field (1-2); the maximum field allowable is related to the dielectric strength at the operating temperature. This is followed by an isothermal decrease of the electric field (Path 2-3).

The process proceeds with a further adiabatic application of electric field of opposite sign (Path 3-4) and an isothermal decrease of electric field (Path 4-1). The cycle is considered to be the most efficient in terms of energy conversion between two working temperatures [90]. The efficiency between two reservoirs of hot T_h and cold T_c temperatures is:

$$\eta_{Carnot} = 1 - \frac{T_c}{T_h} \quad (\text{Eqn. 14})$$

The Carnot cycle for pyroelectric energy harvesting faces significant practical limitations, for example the need for adiabatic temperature changes (electro-caloric) and two isothermal paths. The maximum temperature variation realisable by applying electric fields is also limited to only a few degrees [89] [90]. The Carnot cycle, while impractical, is often used for comparative purposes to other cycles.

4.2 Resistive cycles

A simple approach to using pyroelectric energy harvesting is to connect the material to a resistive electrical load and subject it to a temperature change [90]. Such an approach has been examined by van der Ziel [7]. When the pyroelectric harvester operates with an external resistance the change in temperature drives an electric current, equivalent to the change in polarisation, through a resistance; if the load resistance is large then the output voltage is large [89]. Estimation of the optimum energy harvested by simple resistive loading is often based on a sinusoidal variation of temperature and an optimal resistive load depending of frequency and material permittivity (total capacitance). Based on this type of cycle, the conversion efficiency relative to the Carnot cycle is:

$$\eta_{Resistive} = \frac{\pi}{4} \cdot k^2 \cdot \eta_{Carnot} \quad (\text{Eqn. 15})$$

where, k^2 is the electro-thermal coupling factor (Eqn. 11) at temperature T_h . Given the small k^2 values in Table 1 the conversion efficiency is low but the electrical circuits that can be employed are relatively simple.

As examples of resistive loaded systems, pyroelectric cells fabricated using screen-printed PZT films and commercial PVDF films were considered as power sources for autonomous sensors [37]. Pyroelectric currents of 10^{-7} A and charges of 10^{-5} C were achieved for 300-360K temperature changes over 100s [37]. Guyomar *et al.* [91] developed a pyroelectric micro-generator using PVDF films that produced 0.32mW for a temperature amplitude of 7K at 0.2Hz. Increased power could be produced by increasing the temperature amplitude, frequency and using higher pyroelectric coefficient materials; e.g. PMN-PT single crystals (see Table 1). Xie *et al.* [28] examined pyroelectric

harvesters using PMN-PT, PVDF and PZT with peak power densities of 0.33, 0.20 and 0.12 mW cm⁻² respectively. Again, large areas and high pyroelectric coefficients were advantageous. While the power output levels are relatively low, the advantages of this approach are that a large range of working temperatures is possible [31] and it is easy to implement. Sebald *et al.* [31] considered harvesting natural temperature variations due to temperature changes of clothing as they moved from the inside to outside. Power peaks up to 0.2 mW cm⁻³ were predicted with a mean power of 1 μW cm⁻³; thinner structures could provide faster temperature variations. The impact of sample geometry and operation frequency has also been examined [92] [58].

One limitation of using simple resistive loading and applying no external electric field is that if a ferroelectric is subjected to temperatures above the Curie temperature there will be depolarisation of the material (see Figure 1). When the ferroelectric is subsequently re-cooled below T_c , in the absence of an applied electric field, there is no longer any net polarisation (and therefore no pyroelectric behaviour) since the ferroelectric domains are now randomly aligned. For this reason, while high pyroelectric activity takes place around the ferroelectric to paraelectric phase transition (Figure 1) [46], resistive generators using ferroelectrics tend to be limited to temperatures below the Curie temperature and transform only a fraction of the available heat into electricity [82].

4.3 Synchronised electric charge extraction (SECE)

The synchronised electric charge extraction process involves extracting the charge generated when the maximum temperature is reached and the stored energy is at a maximum and extracting the charge again when the temperature is a minimum [90] [93]. Figure 3b shows the polarisation-field paths in a SECE cycle. During Path 1-2, the pyroelectric is heated resulting in an increase in open-circuit voltage (Eqn. 6). The electric field is then discharged and the field reduced to zero under isothermal conditions (Path 2-3). The pyroelectric is then cooled under open circuit (Path 3-4) and then isothermally discharged (Path 4-1). For most materials the coupling is weak ($k^2 \ll 1$) and the efficiency can be simplified to:

$$\eta_{SECE} = k^2 \cdot \eta_{Carnot} \quad (\text{Eqn. 16})$$

It can be seen that the cycle is more efficient than resistive cycle (Equation 15) and has advantages in that voltage control is not required and no pre-determination of working temperatures or their control is necessary [90]. However, like the resistive cycle, the main disadvantage associated with this harvesting technique is the low value efficiency due to the low k^2 values (Table 1).

4.4 Synchronised Switch Damping on Inductor (SSDI) Cycle

The SSDI approach for pyroelectric harvesting is based on an approach initially developed for vibration damping. In this case the voltage on the pyroelectric material is switched on an inductor at each maximum or minimum temperature so that the electric-field is rapidly reversed at low loss.

Figure 3c shows the basic process and the main difference to SECE is that the electric field is not reduced to zero but to an almost opposite value. Starting from Point 1 the temperature of the material is increased in open-circuit conditions and a positive electric field is developed (Path 1-2). This induces an electric field E_{M1} on the material due to pyroelectric effect. Upon reaching the maximum temperature, the material is subjected to an isothermal field inversion to $-E_{m1}$ through an external voltage. The ratio of inversion is known as inversion quality $\beta = E_{m1}/E_{M1}$ and for perfect inversion $\beta = 1$ [90]. In process 3-4, the temperature is then reduced and the absolute value of electric field increases. On reaching point 4, the inversion process is repeated and the process continues. For weakly coupled materials, the efficiency relative to the Carnot cycle is:

$$\eta_{SSDI} = k^2 \left(\frac{1+\beta}{1-\beta} \right) \eta_{Carnot} \quad (\text{Eqn. 17})$$

The SSDI cycle has since been modified to a synchronised switch harvesting on inductor (SSHI) cycle, but with similar conversion levels. The type of circuit to implement a SSHI will be described later in this review.

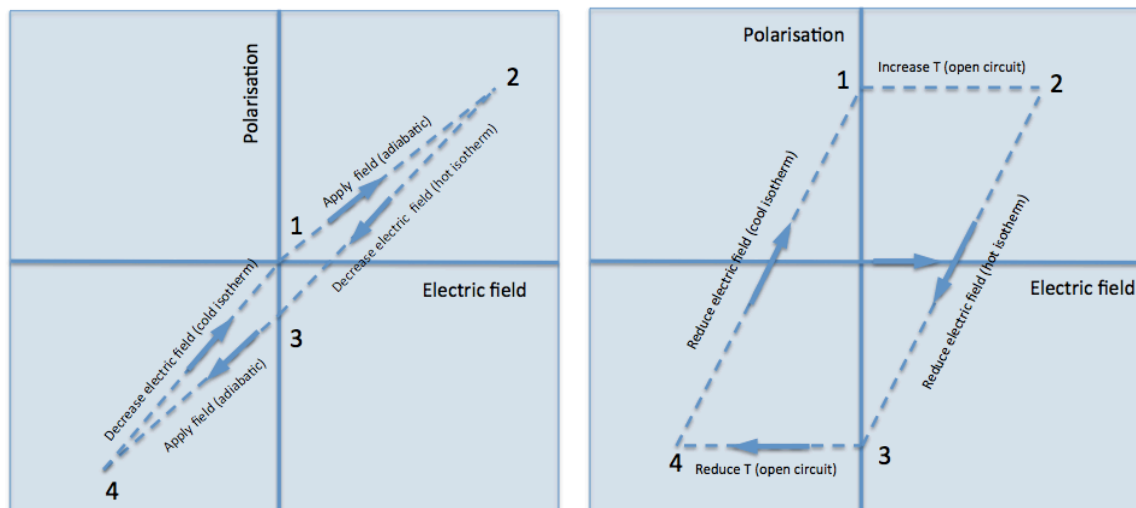

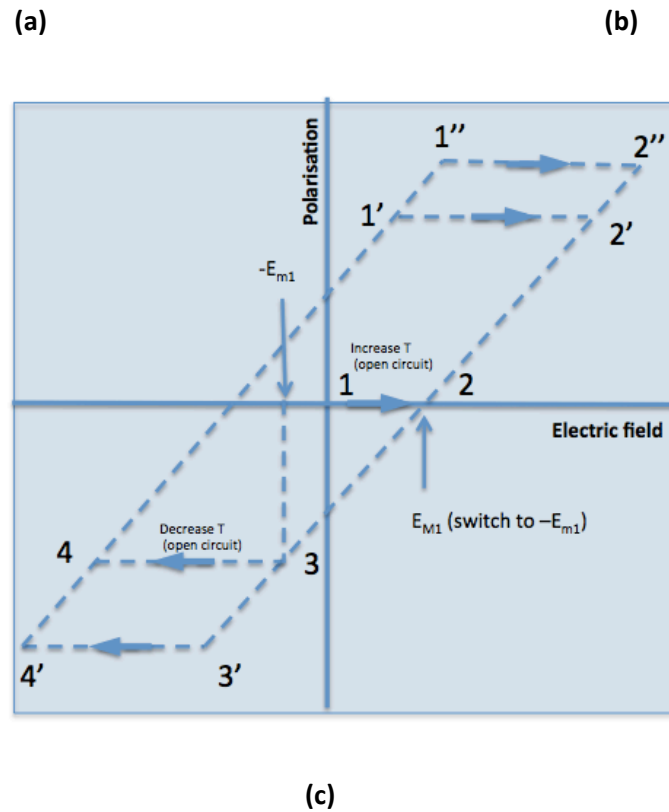

Figure 3. Example cycles. (a) Carnot (b) synchronised electric charge extraction (SEC) and (c) synchronised switch damping on inductor (SSDI). Adapted from [90] [89].

4.5 Olsen Cycle

In this section a different approach is described that relies on the fact that thermally modulating the polarisation of the material also varies its dielectric constant and hence its capacitance [89]. The potential of ‘thermo-dielectric’ generation has been considered for over 50 years [4] [9] [6] [94] and the initial history of this work is well described by Khodayari et al. [3]. Olsen proposed a working pyroelectric cycle between two different polarization curves obtained at two distinct temperatures for a material. This type of pyroelectric converter is an electric form of heat engine and Olsen et al. presented a number of important papers and patents on thermal cycles for harvesting [95] [83] [96] [89] [84] [97] [98] [99] [100] [101]; it has also been examined in detail by a number of researchers [102] [102] [68] [38] [82] [103] [104] [105] [85] [106] [107] [54] [108] [71] [109]. The role of the secondary pyroelectric and phase transitions on such cycles has been well reported by McKinley et al. [54].

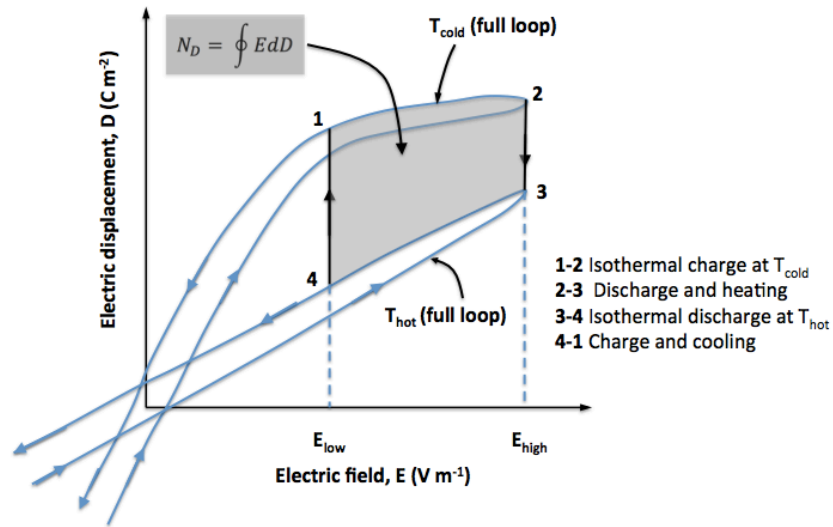

Figure 4. (a) Electric displacement versus electric field (D-E) for pyroelectric material at two temperature (T_{cold} and T_{hot}), adapted from [57] [98]. The material (capacitor) is charged isothermally during the cool portion of its thermal cycle (1 \rightarrow 2) after which it is heated (2 \rightarrow 3). The effect of the heating is to decrease the polarisation (displacement) of the material and hence its dielectric constant and capacitance releasing electrical energy isothermally into an external circuit (3 \rightarrow 4). The device is finally cooled and returned to the beginning of the cycle (4 \rightarrow 1).

Olsen introduced a clockwise harvesting cycle defining electrical work N_D as the area between two isotherms in an electric displacement – field (D-E) diagram which is shown in Figure 4 [96]. The approach is an electrical analogue of the Ericsson heat engine cycle [83] and has two isothermal (1–2, 3–4) and two isoelectric paths (2–3, 4–1) which span the area N_D . The integral of $E dD$ around the closed cycle corresponds to the electric work available after heat absorption and rejection:

$$N_D = \oint E dD \quad (\text{Eqn. 18})$$

In essence, a ferroelectric capacitor is charged at a cold temperature and then discharged first by heating it to a higher temperature and then by reducing the applied electric field. [57]. These steps act to effectively reverse the direction of conventional polarisation-field hysteresis loops which convert electrical energy into heat [95]. With this type of harvesting cycle the net trade-off of employing an external electrical field is a higher efficiency compared to most other cycles [98]. For identical boundary conditions of heat source temperature, the Olsen cycle with ferroelectric lead zirconate stannate titanate ceramic (PZST) transforms up to ten times more thermal energy into electricity than using high impedance resistors [89]. To generate high levels of power from the Olsen cycle the ability to apply large electric fields is advantageous, i.e. to maximise E_{HIGH} in Figure 4, and

therefore materials with a high dielectric strength are desirable to avoid field-induced crack propagation [70]. Table 2 summarises some of the proposed temperature ranges, electric fields and resulting energy densities. While polycrystalline ceramics have a dielectric strength of 3-4 kV/mm, single crystals can withstand electric fields up to 12-14 kV/mm, and oriented thin-films electric fields up to 60-80 kV/mm [110]. Polymer-based PVDF materials are attractive materials because of their low cost, mechanical flexibility (compliance) and they have been used at electric fields up to 120kV/mm [111]; for example compare the electric fields employed for the PVDF based systems with the ceramics in Table 2. While high electric fields and temperature ranges are desirable they can cause high leakage currents across the active material, degrading the available energy [38].

The need to employ external electric field leads to this cycle being employed for larger energy harvesting systems, rather than nano- or micro-scale devices; making is less suitable for wireless power systems. The energy harvesting capability of [001] oriented $68\text{PbMg}_{1/3}\text{Nb}_{2/3}\text{O}_3\text{-}32\text{PbTiO}_3$ (PMN-32PT) single crystal was measured by Kandilian *et al.* [57] by successively dipping the material in oil baths at temperatures 80°C and 170°C and cycling the electric field between 2 and 9 kVcm^{-1} . This energy density was $100\text{ mJ cm}^{-3}/\text{cycle}$, corresponding to 4.92 mW cm^{-3} . It was estimated 40% of this energy resulted from the strain polarization due to the rhombohedral to tetragonal phase transition. For a $0.90\text{Pb}(\text{Mg}_{1/3}\text{Nb}_{2/3})\text{O}_3\text{-}0.10\text{PbTiO}_3$ ceramic the harvested energy reached 186 mJ cm^{-3} for a 50°C temperature change and an electric field change of 3.5 kV mm^{-1} ; based on an operating frequency of 2Hz with a 10°C temperature change a power level of 100 mW cm^{-3} was considered feasible. The continuous application of electric field in such cycles enables re-polarisation of the material as it cools from above the Curie temperature, this is an additional advantage compared to harvesting cycles that do not apply an electric field.

In addition to increasing the maximum applied field, it is also of interest to work near a phase transition where the polarization is strongly influenced by temperature variations [57]. This has been examined for a range of ferroelectric materials that exhibit phase transitions such ferroelectric-ferroelectric [110] and ferroelectric-to-paraelectric [57]. One disadvantage of this approach is that the working temperature range of the harvester is restricted to the vicinity of the phase transition in terms of both electric field and temperature [32], unlike the resistive cycle approach. The Olsen cycle is suited to operation near the linear polarisation region [110] and performs best with an external electric field operating around the Curie temperature [111]. Due to the required transient change in temperature, the adjustment of the right operation frequency of pyroelectric cycles is crucial for increasing energy transformation [112]. McKinley *et al.* [113] recently reported a novel

thermo-mechanical energy conversion cycle in which the temperature increase in an Olsen-based cycle was combined with a mechanical stress to further decrease the polarisation level; such an approach can be used to generate power at lower temperatures along with the ability to adapt to changing thermal and mechanical conditions.

In summary the Olsen cycle is attractive due to its efficiency and ability to exploit phase transitions with large changes in polarisation. However it is often restricted to operation between two specific temperatures and since its operation cycle is more complex the approach has often been considered for relatively larger systems [82] and less work on small-scale power generation for wireless sensor applications [114].

5. Harvesting from Pyroelectric Devices: *circuit implementation*

In order for an energy harvesting system to be practical it is necessary to extract and store the harvested electrical energy in an external device for future access. This section summarises the electronic circuitry currently available for this purpose which has been examined by a number of researchers [115] [116] [93] [90]. The material is presented in two subsections where the first section considers simple temperature cycling while the second considers systems based on Olsen-type cycles where electrical energy is input into each cycle.

5.1 Energy harvesting from pyroelectric devices using temperature cycling alone

Figure 5 shows the thermoelectric equivalent circuits of a homogeneous pyroelectric cell. The thermoelectric equivalent circuit, Figure 5a represents the conversion of incident thermal power W into a temperature change. The relationship between current, pyroelectric coefficient, area and rate of change of temperature can be expressed by the electrical equivalent circuit in Figure 5b that includes the pyroelectric current source I , the electrical capacitance C_p and resistance R_p resulting in an output voltage V_p . The two parts of the process are functionally linked by Equation 1. Due to the low frequency of the temperature cycle, the source impedance tends to be dominated by C_p , resulting in relatively large open circuit voltages and this is a characteristic that pyroelectric devices share with piezoelectric sources.

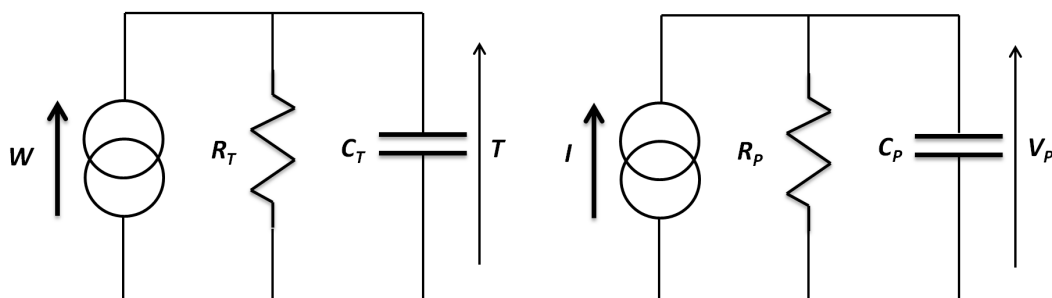

(a)

(b)

Figure 5. Thermoelectric equivalent circuits of a homogeneous pyroelectric cell. The circuit on the left (a) represents the conversion of incident thermal energy W into a change in temperature, T . Equivalent circuit (b) represents the conversion of current generated by the pyroelectric process into an output voltage V_p . The two parts of the process are connected by the Equation 1 and C_T , R_T , C_P and R_P are the thermal and electrical capacitances and resistances respectively.

Having converted thermal energy into electrical energy (charge) it is necessary to transfer the electrical energy to an external load (e.g. resistor) or storage medium (e.g. capacitor) using a suitable interface. The simplest possible interface is a resistive load connected directly across the terminals of the device, i.e. a resistive cycle. The pyroelectric current I , flows through the resistor as the temperature is cycled and electrical power is dissipated in the electrical load. Even under optimum conditions, where the load resistor is matched to the output impedance of the pyroelectric device, the efficiency of this arrangement is low; for example Van der Ziel [7] reported efficiencies as low as 0.025%. In a variant of this idea, electrical energy can be transferred to a storage device (such as a capacitor or storage battery), for future discharge. Since pyroelectric devices are bidirectional an alternating thermal drive generates an alternating current and rectification is necessary to harvest the energy. A typical arrangement, sometimes referred to as the ‘standard interface’ is shown in **Figure 6** [91]. The pyroelectric energy source is represented by the equivalent circuit of **Figure 5b** and this is connected to a diode bridge (D1 – D4) providing full-wave rectification of the output voltage from the device. The harvested energy is stored on the capacitor C_L and dissipated by the resistive load represented by R_L where the electrical time constant $R_L C_L$ is chosen to be significantly longer than the thermal cycling period to minimise any ripple on the output voltage.

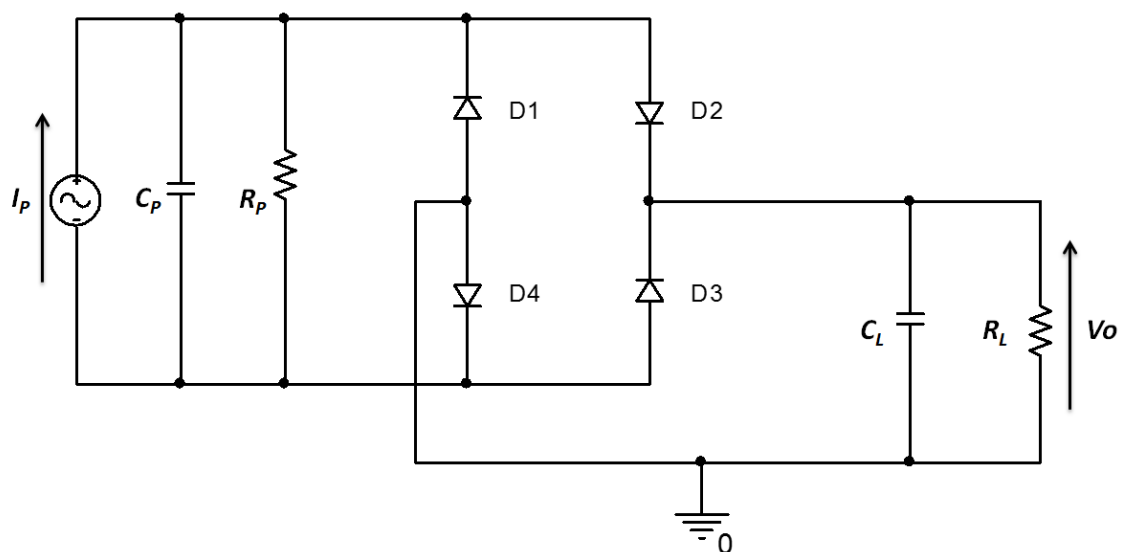

Figure 6. ‘Standard’ interface circuit consisting a diode bridge full-wave rectifier interfacing a pyroelectric source (equivalent circuit of Fig 5b consisting of I_p , C_p , & R_p) and a load consisting of C_L & R_L . I_p is synchronised to the temperature variation and the time constant $C_L R_L$ is chosen to be much longer than the period of the temperature cycle to minimise the ripple on the output voltage.

Although the arrangement shown in **Figure 6** is practical in that pyroelectric energy can be extracted and stored for future use, its efficiency is similar to that obtained by connecting a resistor directly across the device. An improved method to extract pyroelectric energy should recognise the characteristics of the source, such as a current source terminated by a resistance and capacitance in parallel (dominated by C_p), and increase the voltage developed across the load. For example, the open circuit voltage developed by the source could be coupled to the load using an amplifier to increase the load voltage and hence available power. However, amplifiers require power and given the small amount of energy generated, the efficiency of such a system is likely to be too low for the method to be viable. A more successful approach is based on a switched (i.e. non-linear) arrangement in which charge is extracted at points of maximum and minimum temperature, i.e. when the stored electrical energy is also a maximum. This method has origins in vibration damping of mechanical structures [117] [118] and has been applied extensively to energy harvesting from piezoelectric transducers [119]. Due to the similarities between piezoelectric and pyroelectric transducers it is no surprise that these synchronous methods, such as that in **Figure 3c**, also work well with the latter class of devices.

The arrangement shown in **Figure 7** is one example of the nonlinear approach applied to pyroelectric harvesting [119]. This circuit is simply the ‘standard’ interface of **Figure 6** to which has been added an inductor L that can be connected in shunt across the source by closing the switch S . This nonlinear process is called *synchronised switch harvesting on inductor* (SSHI) charge extraction and allows the high impedance, essentially capacitive nature of the source, to be turned to advantage. When the switch is closed L_p and C_p form a parallel tuned circuit, driven by I_p to function as a forced oscillator with a resonant frequency $\omega_0 = 1/\sqrt{L_p C_p}$. If S is closed at the peak of temperature cycle and assuming ω_0 is much higher than the temperature cycling frequency, it is possible to capture most of the energy generated by the pyroelectric device. The voltage across the tuned circuit can be many times larger than the natural open circuit voltage of the pyroelectric device (depending on the quality factor of the inductor and resistive losses) resulting in a significantly increased load voltage.

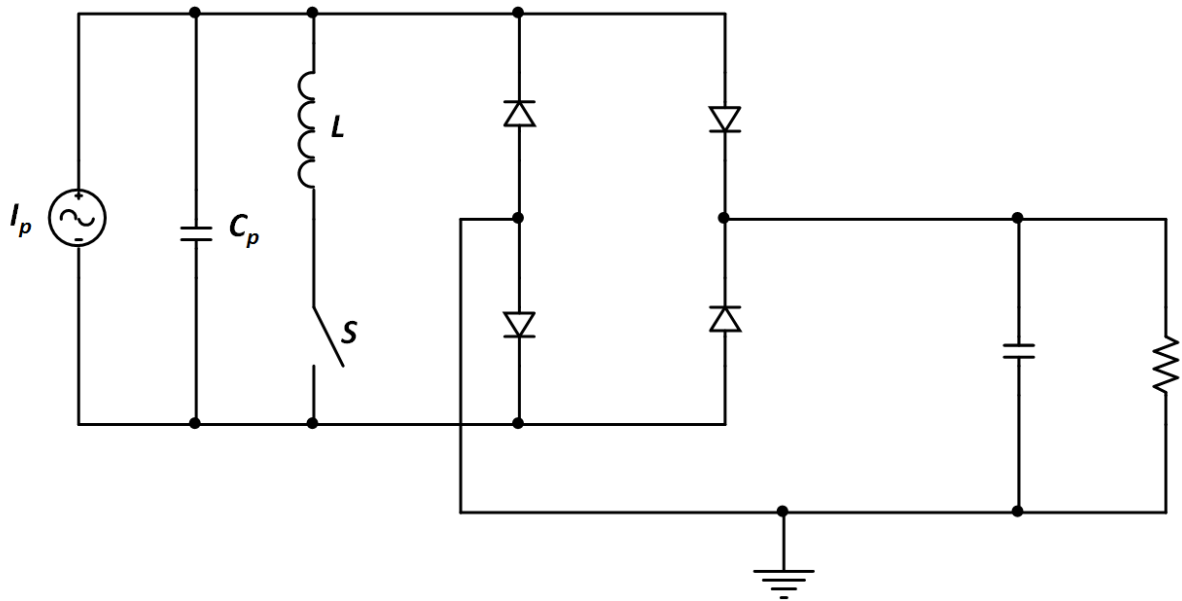

Figure 7. Parallel synchronised switch harvesting on inductor (SSHI) charge extraction interface circuit. When S is closed L_p and C_p form a parallel tuned circuit, driven by I_p to function as a forced oscillator with a resonant frequency $\omega_0 = 1/\sqrt{L_p C_p}$. If S is closed at the peak of temperature cycle and assuming ω_0 is much higher than the temperature cycling frequency, it is possible to capture most of the energy generated by the pyroelectric device.

The harvested energy is temporarily stored as magnetic energy in L_p , the only limitation on this process being losses in the circuit; these are principally due to the finite resistance of the switch and the inductor windings. The approach has much in common with the buck/boost power converter whose high efficiency stems essentially from the ability of an inductor to store energy ‘loss-lessly’ as a magnetic field. Using this method, significant improvements in efficiency compared to the ‘standard’ interface have been reported [91], although there is scope for further circuit development to determine the ultimate limitation on the enhancement obtainable.

5.2 Energy harvesting from pyroelectric devices using the Olsen cycle

Upgrading the pyroelectric equivalent circuit with storage capability enables isoelectric voltage operations, similar to an isobaric process in a thermodynamic Ericsson cycle [89]. It has been suggested that under ideal conditions a pyroelectric converter using the Olsen-type cycle shown in Figure 4 could achieve about 15% efficiency or about half the capability of a theoretical Carnot cycle [89]. In order to achieve this performance it is necessary to be able to charge and discharge the device as efficiently as possible (Paths 1-2 and 3-4 of the cycle in Figure 4b). In [99] it was suggested that if standard switched-mode methods were employed an efficiency of 95% - 98% could be achieved in this part of the process. These circuits use inductors to provide magnetic energy storage and, as described in section 5.1, the process is essentially loss-less.

6. Pyroelectric harvesting devices

6.1 Nanostructured and micro-scale materials and devices

For pyroelectric harvesters the operating frequency of the device is often small (typically much less than 1Hz). In fluid based systems the frequency of operation is limited by heat transfer between the pyroelectric and the working fluid that is oscillating between hot and cold sources. To increase the operating frequency, radiative heat transfer at the nano-scale has been examined by Fang *et al.* [120]. Energy transfer by thermal radiation between two semi-infinite solids is almost instantaneous and can be enhanced by several orders of magnitude from the conventional Stefan-Boltzmann law if their separation is a distance smaller than a characteristic wavelength, given by Wien's displacement law. A device was analysed by modelling nano-scale radiative heat transfer between a pyroelectric that was subjected to oscillation using piezoelectric pillars in a vacuum between hot and cold aluminium surfaces. A device using 60/40 porous poly(vinylidene fluoride–trifluoroethylene) was predicted to have a 0.2% efficiency and a 0.84 mW/cm^2 electrical power output for the cold (273K) and hot sources (388K). A pyroelectric plate made from 0.9PMN-PT composite thin films achieved a higher efficiency (1.3%) and a larger power output (6.5 mW/cm^2) for a temperature oscillation amplitude of 10 K at a temperature of 343 K at a relatively high frequency of 5 Hz.

A simple approach to improve the rate of temperature change and increase the pyroelectric current is to reduce the thickness of the pyroelectric, such as using thin films. Yang *et al.* [87] demonstrated a flexible hybrid energy cell for simultaneously harvesting thermal, mechanical, and solar energies. A ZnO-poly(3-hexylthioohene) hetero-junction solar cell was used for harvesting solar energy while a PVDF-based pyroelectric and piezoelectric nano-generator was built on its bottom surface for harvesting thermal and mechanical energies. A pyroelectric coefficient of $\sim 44 \text{ } \mu\text{C/m}^2 \text{ K}$ was measured. Using a lithium-ion battery to store the harvested energy the device could drive LED devices. Pyroelectric 'nano-generators' based on ZnO nanowire arrays were reported by Yang *et al.* [41]. A higher pyroelectric voltage and current coefficients were determined for the nano-generator compared to bulk and film material; this was thought to be due to the preferred orientation of the ZnO nanowire array. Yang *et al.* also presented an active temperature change sensor based on a PZT generator [59]. The system consisted a PZT microwire on a thin glass substrate with electrical contacts at its ends and packaged in polydimethylsiloxane (PDMS). The ferroelectric wire was polarised at room temperature and the output current and voltage increased linearly with the rate of temperature change and to demonstrate its potential the harvested energy was used to power a liquid crystal display. A pyroelectric generator based on PZT thin film (175 μm thick) exhibited a

pyroelectric coefficient of approximately $-800 \mu\text{C}/\text{m}^2\text{K}$ with a maximum power density of $0.215 \text{ mW}/\text{cm}^3$ based on the open-circuit voltage and short-circuit current density [66]. The power of the pyroelectric generator was used to charge a lithium ion battery and a single output pulse could charge a LCD (Figure 8). Lead-free KNbO_3 [81] nanowire/PDMS polymer with Ag and indium tin oxide (ITO) electrodes as a flexible nano-generator have also been fabricated where the output could be tuned by the electric field due to changes in ferroelectric domain orientation. The nanowires were grown by the hydrothermal method and were approximately 150nm diameter. The bulk pyroelectric coefficient of KbNO_3 is $50 \mu\text{C}/\text{m}^2\text{K}$ while the effective coefficient of the nanowire-polymer mixture was $8 \mu\text{C}/\text{m}^2\text{K}$ due to the presence of the non-polar PDMS; the proposed advantage of the PDMS was to provide flexibility.

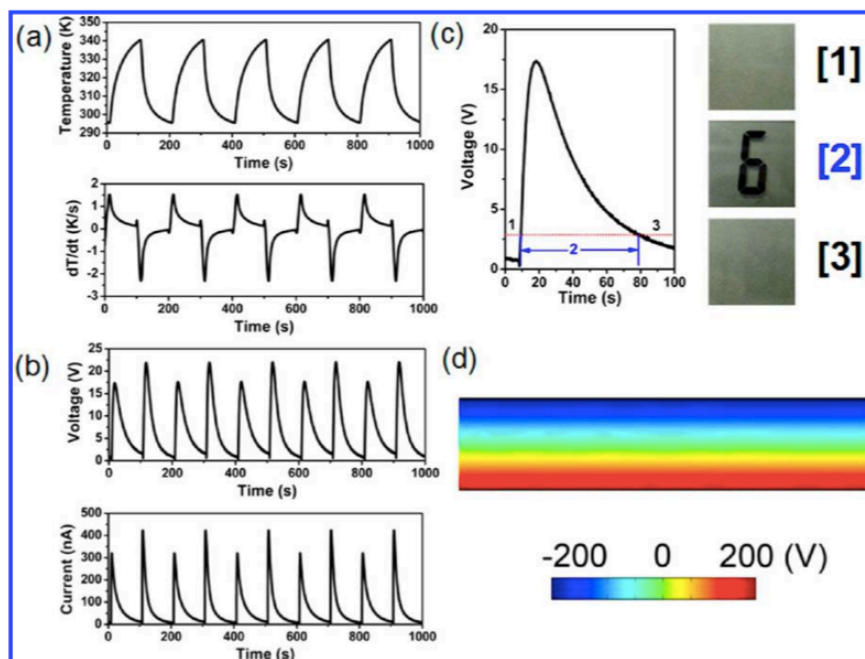

Figure 8. a) Cyclic change in temperature of a PZT thin-film pyroelectric generator and corresponding differential temperature (dT/dt). (b) Output voltage and current of the generator after rectification by a full-wave bridge circuit. (c) Enlarged single output voltage peak, where it is used to drive a LCD in the region "2". (d) Calculated electrical potential distribution across the PZT film [66]. Reprinted with permission from American Chemical Society. Copyright (2012) American Chemical Society.

At the micro-scale Hsiao et al. [121] [63] [122] have reported the etching of pyroelectric surfaces and etching the electrode structure to improve energy harvesting performance. This was based on the observation that partially covered top electrodes provide a higher current and voltage responsivity than a fully covered electrode since it allows the pyroelectric layer to be in closer contact with the heat source [123]. Hsiao et al. showed that a meshed top electrode and trenched pyroelectric improved the responsivity of the PZT. One issue is that using a thicker pyroelectric element leads to a larger total heat capacity that reduces the temperature change [63] for a specific energy input. The

purpose of trenching the PZT was to enhance the rate of temperature change due to a lateral temperature gradient as a result of the trenched architecture. A vortex-like electrode with a deep structure was also produced [122] by sandblasting which improved the harvested power by 11% compared to a fully covered electrode.

The size of the pyroelectric element has also been used to tailor the phase transition temperatures in ferroelectric nanowires, enabling a 'giant' pyroelectric response [124]. It was shown using Landau-Ginzburg-Devonshire phenomenological theory that it is possible to tune the pyroelectric coefficient by changing the nanowire radius and the nature of the surrounding media e.g. template material, gas or gel, since the ferroelectric-ambient interface determines the surface energy properties. While the predicted efficiency of these nanoscale materials was low at room temperature it was noted that as the temperature decreased the efficiency tends to the Carnot cycle efficiency, making it suitable for low temperatures, e.g. space applications. Nanowires of GaN and ZnO have been examined using first principles-based density functional theory (DFT) calculations and considered the size dependency of the piezoelectric coefficients and a 'giant piezoelectric size effect' was identified [125]; it would be interesting to examine the effect of scaling on pyroelectric coefficients and nano-structured materials. The reader is referred to a review by Lingam et al. for a further discussion on nano/microscale pyroelectric harvesters [18].

6.2 Hybrid generators

Since all pyroelectrics are piezoelectric it is perhaps not surprising that researchers have attempted to combine both pyroelectric and piezoelectric harvesting. The generation of an electric current under short circuit conditions or an electric potential in open circuit conditions as a result of the change in polarisation with a temperature change has analogies with piezoelectric harvesting. **Table 3** compares the relevant equations for a pyroelectric subjected to a temperature change (ΔT) and piezoelectric subjected to a stress ($\Delta\sigma$) with similarities in the relationships between current, voltage and stored energy between temperature change and applied stress under both open and closed circuit conditions. Due to their similarities there is interest for potential hybrid piezoelectric-pyroelectric harvesting systems [87] [126] [127] whereby a combination of temperature change and stress is applied. In such systems care must be taken to ensure the changes in polarisation are constructive and enhance the power generation of the harvesting device [62]. As discussed by Sebald et al., the frequencies of temperature and vibration may be different and there is a need to optimise the electronics for such a hybrid system [90].

Table 3: Comparison of relevant equations for pyroelectric $p=dP_s/dT$ ($C\ m^{-2}\ K^{-1}$) and piezoelectric systems $d_{ij}=dP_s/d\sigma$ ($C\ N^{-1}$ or $C\ m^{-2}\ /N\ m^{-2}$) and ϵ_{33}^T is permittivity at constant stress.

	Pyroelectric	Piezoelectric
Charge (Q)	$Q = p \cdot A \cdot \Delta T$	$Q = d_{ij} \cdot A \cdot \Delta \sigma$
Short-circuit current ($i = \Delta T / \Delta t$)	$i = p \cdot A \cdot \frac{\Delta T}{\Delta t}$	$i = d_{ij} \cdot A \cdot \frac{\Delta \sigma}{\Delta t}$
Open-circuit voltage ($V=Q/C$)	$V = \frac{p}{\epsilon_{33}^T} \cdot h \cdot \Delta T$	$V = \frac{d_{ij}}{\epsilon_{33}^T} \cdot h \cdot \Delta \sigma$
Stored energy ($\frac{1}{2}CV^2$)	$E = \frac{1}{2} \cdot \frac{p^2}{\epsilon_{33}^T} \cdot A \cdot h \cdot (\Delta T)^2$	$E = \frac{1}{2} \cdot \frac{d_{ij}^2}{\epsilon_{33}^T} \cdot A \cdot h \cdot (\Delta \sigma)^2$

Lee et al. [126] fabricated a stretchable, hybrid piezoelectric-pyroelectric nano-generator based on a micro-patterned piezoelectric P(VDF-TrFE) polymer, micro-patterned PDMS-carbon nanotube (CNTs) composite and graphene nanosheets, see Figure 9. The PDMS-CNT was used to make the device flexible and also serve as a robust electrode on the base of the device. Graphene was used as a top flexible electrode to allow a fast temperature gradient on the device due to its high thermal conductivity. The potential of the material harvest both mechanical loads (σ) and temperature changes (ΔT) was examined. The total change in polarisation is expressed as:

$$\Delta P = d \cdot \sigma + p \cdot \Delta T \quad (\text{Eqn. 19})$$

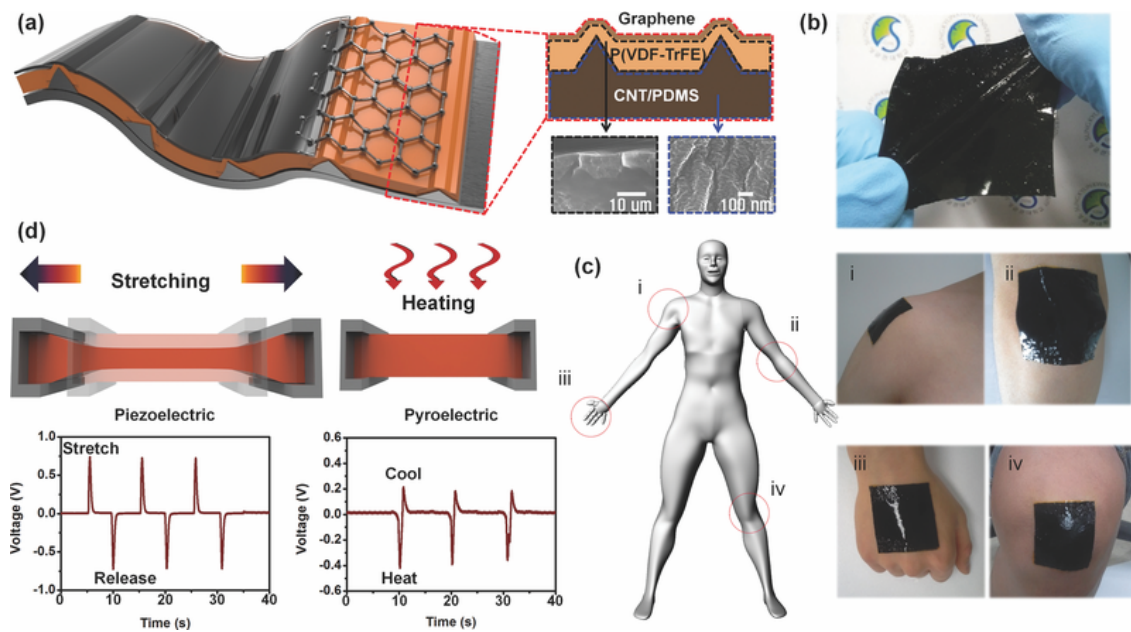

Figure 9. (a) Schematic of stretchable, hybrid piezoelectric-pyroelectric nano-generator (b) image of device (c) location of devices on body (d) piezoelectric output on application of strain and pyroelectric output on changing temperature [126]. Reprinted with permission of John Wiley and Sons.

Erturun *et al.* [62] examined combined harvesting using a heating lamp directed at a vibrating beam. Both effects were initially investigated independently and subsequently coupled. In some cases the combination of beam vibration with thermal cycling had a negative effect on scavenged energy and this indicates the potential complexities in such an approach, especially to differences in frequency of temperature and mechanical oscillations. However, the use of ‘piezoelectric-pyroelectric-harvesters’ potentially offers an interesting method of enhancing power.

6.3 Pyroelectric ‘systems’ and active oscillators

Oak Ridge National Laboratory [128] [129] designed a MEMS based cantilever harvesting system based on a thermally cycled pyroelectric capacitor that acts as a bimorph cantilever. The bimorph operates between two surfaces, one heated by waste heat and the other is a cold heat sink (Figure 10). Proof masses are placed at the cantilever tip to ensure good thermal contact to the hot and cold surfaces. When the cantilever is heated it deforms due to a thermal expansion mismatch between the bimorph layers that leads to it contacting the cold surface, making the structure cool and deform in the reverse direction and then making contact to the hot surface. This cyclic deformation leads to the cantilever alternately contacting the hot and cold surfaces at the resonant frequency of the cantilever to generate a pyroelectric current. The use of a MEMS approach means that large arrays

of devices could be used to increase power and this interesting approach allows the device to potentially operate at high frequencies, up to 20Hz or higher [130] [2].

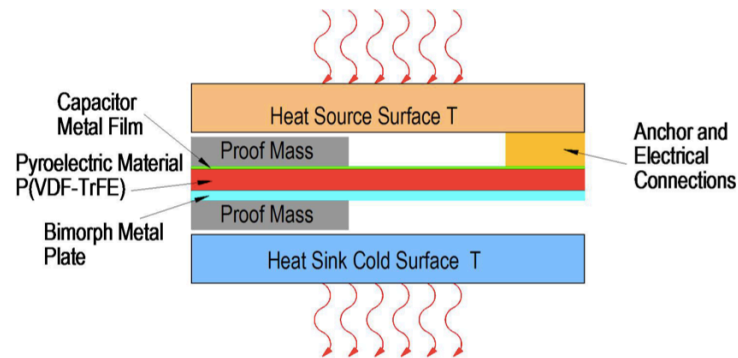

Figure 10. Side view of the pyroelectric bimorph cantilever showing the cantilevered capacitor thin film layers. The energy harvester consisting of a bi-material cantilever which alternately contacts hot and cold surfaces and generates a current in the pyroelectric capacitor [130]. Reprinted with permission of S.R.Hunter.

Another approach to increase operating frequency uses liquid-based switchable thermal interfaces to convert a spatial temperature gradient into temporal temperature oscillations [29] [114]; the system operates in an Olsen type cycle as shown in Figure 4. In this work a plate with a pyroelectric material oscillates up and down between a high temperature source and a cold heat sink and repeatedly makes thermal contact to undergo temperature oscillations, Figure 11. In the thermally conducting state, the pyroelectric is pressed against the hot or cold surface using a linear actuator and liquid droplets at the interface deform to make them merge into a continuous thin liquid layer of low thermal resistance. In the non-thermally conducting state, the pyroelectric material is physically separated from the hot and cold surfaces and the liquid on the pyroelectric interface exists as discrete droplets. By creating a hydrophilic pattern on the surfaces the rupture distance was reduced, thus reducing the distance required and increasing the operating frequency. A device was demonstrated at frequencies of the order of 1Hz with a power density of 110 mW/cm^3 .

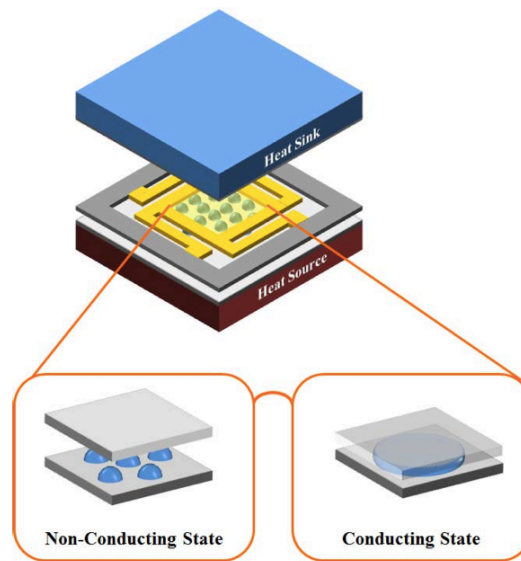

Figure 11. (a) Pyroelectric energy harvesting module. Electrode assembly containing a pyroelectric material is actuated up and down and makes alternating thermal contact with the heat source (hot side) and sink (cold side) via switchable thermal interfaces [114]. Reprinted with permission from Elsevier.

Huesgen et al. [131] [132] [133] presented a micro heat engine manufactured using silicon micro-technology based on a cavity filled with a liquid-gas phase-change fluid that develops a reciprocating motion between heat source and heat sink. A bistable membrane was used that buckled during expansion and contraction of a phase-change fluid to generate upward and downward motion between the heat source and sink. The engine was self-starting and self-regulating with a temperature dependent operation frequency (e.g. 0.7Hz for a 37K temperature difference). The micro ‘thermo-mechanic-pyroelectric’ energy generator (μ TMPG) had a measured power output of 3μ W for a temperature difference of 79.5K. An optimised design was proposed based on a similar process with a power output of 39.4 mW for the same temperature difference that used <111> PMN-0.13PT single crystal (Figure 12) [55]. The potential benefits of pulsed heat transfer has been considered by McKay et al. [134] and Carlioz et al. who have attempted to combine piezoelectric materials with hard and soft magnetic materials whose attracting forces vary with temperature [135].

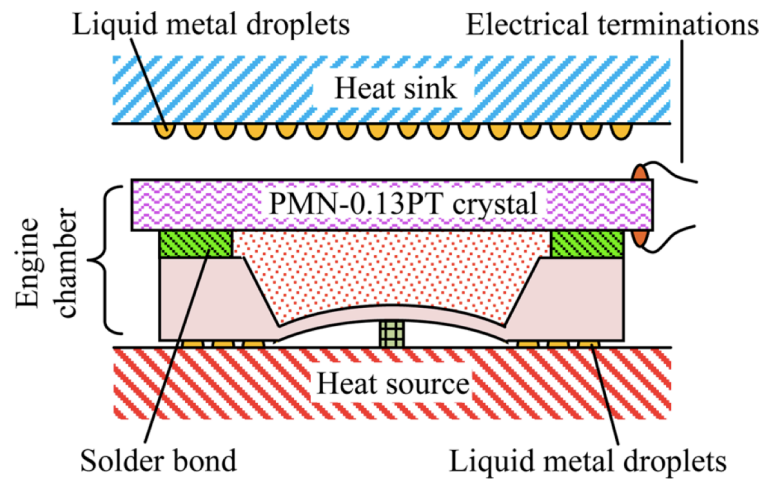

Figure 12. Illustration of proposed μ TMPG. The $\langle 111 \rangle$ PMN-0.13PT crystal mechanically displaces up and down via a bistable membrane as it repeatedly heats at the source and cool at the sink [55]. Reprinted with permission AIP Publishing LLC.

A micro-system consisting of a carbon nanotube film integrated with a PZT cantilever for harvesting light and thermal energy was reported by Kotipalli et al. [65]. The carbon layers served as an efficient absorber of thermal radiation, resulting in a shape change of the carbon layer and induced bending into the piezoelectric cantilever. A power of $2.1\mu\text{W}$ was generated from a light intensity of 0.13 W/cm^2 . A carbon nanotube film – cantilever was observed to generate both AC voltages due to self-reciprocation of the cantilevers and also generate a DC component as a result of the thermoelectric properties of the carbon layer [136].

Finally, Zhang et al. [137] showed that a pyroelectric under solar radiation can produce energy as a result of fluctuations due to wind to induce the temperature fluctuations that is necessary to exploit the pyroelectric effect. This inspired a pyroelectric-based solar and wind harvester developed by Krishnan et al. [64]. The mode of operation is to concentrate solar radiation onto a pyroelectric material to induce a large temperature change. To create the necessary temperature change a wind turbine was used to create optical modulation with a gearing system to optimise the modulation period to ensure large temperature changes. For a PZT prototype a maximum power density $421\mu\text{W/cm}^3$ was produced. One of the initial reports of using ferroelectric materials to harvest solar radiation is by Hoh [6] who considered a spinning space vehicle and the change in polarisation and dielectric constant of a ferroelectric with temperature. Solar power generation using pyroelectrics has been considered by van der Ziel [7] who highlighted the need for focussing of radiation for pyroelectric harvesting.

7. Conclusions

Compared to other forms of energy harvesting and thermal harvesting such as thermoelectric generators, the use of pyroelectric harvesting to generate electrical energy from temperature fluctuations is less well studied. While the efficiencies can be high for specific thermal and electric cycles, especially Olsen-based cycles, the inability to induce high frequency temperature fluctuations currently limits the amount of power that can be harvested, this is in contrast to mechanical oscillations where mechanical vibrations over 10^2 Hz are relatively easy to implement.

With regards to potential harvesting cycles, resistively loading the pyroelectric element is relatively simple and can operate in a range of operating environments and temperatures although the material must clearly maintain its polarised nature. The use of natural temperature fluctuations to generate a pyroelectric current as surface charges are released on heating a pyroelectric is generally of low efficiency. Other methods, such as employing the Olsen thermal cycle with corresponding changes in capacitance and material phase changes can increase both the efficiency and the quantity of the power generated compared to simple resistive loading. Such systems are often designed to operate within specific temperatures and electric field ranges and as a result Olsen-type systems tend to be designed to operate in specific locations and manufactured from bulk materials for larger-scale harvesting systems, rather than low power systems for wireless sensor systems. Limited systems have employed the Olsen-type cycle at the micro to nano-scale.

In an effort to improve power capability attempts to increase the operational frequency are often undertaken, such as the generation of mechanical oscillations from a temperature gradient. The creation of pyroelectric harvesting materials and systems at the nano-scale may also offer opportunities for operation at higher frequencies. This can be coupled with the development of new materials with improved pyroelectric coefficients especially for harvesting applications. Materials and material architectures with improved heat transfer are of interest to increase rates of temperature change or improved FOMs. Composite material systems or design of materials with high FOM to tune the pyroelectric response and mechanical and thermal properties are also potential future avenues of research.

Since the pyroelectric effect originates from spontaneous polarisation within the material, all pyroelectric materials are also piezoelectric, therefore hybrid pyro-piezo harvesting systems are of interest. In the design of such systems care must be taken to ensure both harvesting mechanisms are working in-phase to enhance power generation. Novel systems that use thermal fluctuations or

thermal gradients to generate to mechanical stress to enhance the secondary or tertiary pyroelectric coefficients are also of interest.

The low efficiency of resistive and synchronised electric charge extraction cycles and low frequency of operation may often result in pyroelectric harvesting being a less favourable harvesting option compared to vibration harvesters or photo-voltaics for low power applications. However in locations with low levels mechanical vibrations or light it is an intriguing option to generate useable power. It can also be used to enhance the power generation capability of mechanical energy harvesting systems.

Acknowledgments

C.R.Bowen would like to acknowledge funding from the European Research Council under the European Union's Seventh Framework Programme (FP/2007-2013) / ERC Grant Agreement no. 320963 on Novel Energy Materials, Engineering Science and Integrated Systems (NEMESIS).