



*Citation for published version:*

Le Blond, S, Li, F & Li, R 2014, 'Cost and emission savings from the deployment of variable electricity tariffs and advanced domestic energy hub storage management'.

*Publication date:*

2014

*Document Version*

Early version, also known as pre-print

[Link to publication](#)

## University of Bath

### General rights

Copyright and moral rights for the publications made accessible in the public portal are retained by the authors and/or other copyright owners and it is a condition of accessing publications that users recognise and abide by the legal requirements associated with these rights.

### Take down policy

If you believe that this document breaches copyright please contact us providing details, and we will remove access to the work immediately and investigate your claim.

# Cost and emission savings from the deployment of variable electricity tariffs and advanced domestic energy hub storage management

S. Le Blond, R. Li, F. Li and Z. Wang  
Department of Electronic and Electrical engineering  
University of Bath,  
Bath, UK  
s.p.leblond@bath.ac.uk

**Abstract** — This paper uses the energy hub concept to holistically model future energy infrastructure in domestic buildings, including energy storage. The developed model allows the deployment of a novel bi-criteria optimization algorithm for minimizing both the cost and emissions of energy hub operation whilst taking advantage of dynamic tariffs. Unlike the traditional flat rate tariffs, the dynamic tariffs employed in this paper reflect variations in the wholesale energy market, and are used as commercial inputs to drive the storage operation and reduce both costs and emissions. The developed algorithm and hub model are used to optimize an example energy hub against four 24 hour periods of loads and dynamic tariffs, one from each season. Annual savings are estimated and compared against a base case, with no storage or management, of a typical house in the UK, showing significant cost and emissions savings.

**Index Terms**-- Cost Benefit Analysis, Energy Hubs, Energy Storage, Green buildings, Microgrids.

## I. INTRODUCTION

Like many regions and states worldwide, the EU has set legally binding targets for the reduction of carbon emissions to mitigate climate change. These are a reduction of 20% below 1990 levels by 2020 and a further reduction of 80% by 2050 [1]. Domestic buildings are responsible for at least 30% of a developed society's energy use, particularly through heating, cooling, lighting and hot water use [2]. As electric vehicles achieve higher market penetration the increase in domestic electrical load will mean households use even more energy.

In future, the shortage of fossil fuels and the penetration of renewables in the generation mix will mean that energy prices are increasingly volatile.

Against such a landscape of volatile pricing, domestic energy storage offers a means of cost avoidance – energy may be bought at times of lower price and discharged to meet loads when the price is higher. Moreover, if a building has local micro generation such as PV or solar hot water, times of high load in the morning and evening will not coincide with peak generation. Storage also offers a way to time-shift the use of this low carbon energy so it may be used where it is generated, saving distribution losses.

At present however, the domestic pricing structures are largely limited to flat and 2-rate tariffs. They are not sufficiently dynamic to reflect the cost variation in the supply system at different locations and over time. Real-time price (RTP) is the most direct way of reflecting dynamics of wholesale price variations. Being able to reflect the dynamics of wholesale energy prices is critically important for demand response and storage operation, particularly in a low carbon system as changes in fuel prices, in demand and in the availability of renewable generation are likely to be more frequent and significant. The traditional flat rate tariff on the other hand, cannot provide the appropriate economic environment against which storage can offer cost avoidance [3].

The operational optimization of energy storage is a complex task. The decision to charge and discharge storage must take into account future loads and carbon emissions factors, which requires weather and building occupancy prediction. Locally, energy itself is not saved by using storage because there are always charging, discharging and standby losses. In certain circumstances local storage may yield an energy saving by avoiding distribution costs, although this is rare. The optimization criteria should therefore be for minimizing monetary costs or emissions costs or as suggested here, a combination of both. The operation of storage must save more emissions and costs than are used over its full lifecycle, including manufacture and disposal, so a lifetime cost per charge cycle should also be factored in.

In order to reach a global optimum, building energy infrastructure should be treated holistically taking into account all energy carriers, taking advantage of any redundant pathways built into the infrastructure. This offers the ability to meet loads with different supplies depending on which offers the lowest instantaneous emissions and monetary cost. Whilst redundancy is not current practice in building energy services it may be economical in future with rising energy costs and cheaper technology. The Energy Hub concept offers a versatile way of holistically modeling building's energy infrastructure.

This paper presents an algorithm for holistically optimizing energy storage using energy hub modeling, taking

advantage of time-varying dynamic tariffs. This development is compared against a typical house in the UK, showing significant cost and emissions savings over the status quo. The rest of the paper is as follows: section 2 discusses energy hubs in detail and then proposes a new storage model. Section 3 describes the optimization algorithm. Section 4 reviews the dynamic pricing from [4] and describes how this price is combined with emissions to provide a cost proxy. Section 5 compares the energy optimization algorithm used in an example hub against a base case to demonstrate cost and emissions savings, followed by the conclusion in Section 6.

## II. ENERGY HUBS

The Energy Hub concept offers a versatile way of modeling the steady state power flows in the energy infrastructure around any bounded geographical area. Originally developed by *ETH Zurich* [5], Energy Hubs comprise of incoming energy carriers at the input ports and outgoing loads at the output ports, with energy conversion and storage technologies between them. Fig. 1 shows an example energy hub. An energy hub can be used to model a domestic building's energy infrastructure, including local storage, renewables and micro-generation. The redundant pathways within a hub offer the chance of ongoing operational optimization, that is, selecting the combination of input supplies that will meet the loads whilst incurring the lowest emissions and costs.

An energy hub may be modeled mathematically using the hub equation: where  $\underline{L}$  is the column vector of different load types,  $\underline{P}$  is a column vector of supply powers and  $\underline{C}$  is the converter coupling matrix. In matrix form this may be written:

$$\begin{bmatrix} L_\alpha \\ L_\beta \\ \vdots \\ L_\omega \end{bmatrix} = \begin{bmatrix} C_{\alpha\alpha} & C_{\beta\alpha} & \cdots & C_{\omega\alpha} \\ C_{\alpha\beta} & C_{\beta\beta} & \cdots & C_{\omega\beta} \\ \vdots & \vdots & \ddots & \vdots \\ C_{\alpha\omega} & C_{\beta\omega} & \vdots & C_{\omega\omega} \end{bmatrix} \begin{bmatrix} P_\alpha \\ P_\beta \\ \vdots \\ P_\omega \end{bmatrix} \quad (1)$$

Where in (1) each Greek letter denotes a type of energy carrier. Each term is  $\underline{C}$  is the steady state efficiency of the converter technology as it converts from one energy type to another, or the same carrier but changing its quality in some way. So for example, the coupling  $C_{\alpha\alpha}$  could denote the conversion efficiency of transformer converting electrical energy from one voltage to another.  $C_{\alpha\beta}$  on the other hand, could be the efficiency of an electrical heater converting electricity to heat.

However, when modeling buildings, it is often the case the instantaneous load is known or future loads can be predicted with a reasonable degree of accuracy. In these situations it is more useful to express the supplies in terms of the loads, using the backwards coupling matrix.

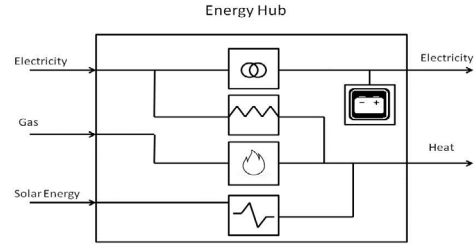

Figure 1. Example energy hub with electrical transformer, resistive heater, gas boiler, solar heat exchanger and battery storage.

This may be written in matrix form:

$$\begin{bmatrix} P_\alpha \\ P_\beta \\ \vdots \\ P_\omega \end{bmatrix} = \begin{bmatrix} D_{\alpha\alpha} & D_{\beta\alpha} & \cdots & D_{\omega\alpha} \\ D_{\alpha\beta} & D_{\beta\beta} & \cdots & D_{\omega\beta} \\ \vdots & \vdots & \ddots & \vdots \\ D_{\alpha\omega} & D_{\beta\omega} & \vdots & D_{\omega\omega} \end{bmatrix} \begin{bmatrix} L_\alpha \\ L_\beta \\ \vdots \\ L_\omega \end{bmatrix} \quad (2)$$

This technique was developed by Fabrizio [6]. Consider a fully connected hub shown in Fig. 2. This represents the most complex hub topology where every load can be supplied from every supply via any converter. Whilst technologically not feasible, this is the most generic case. In practice, for real world hubs, most terms in the in the backwards coupling matrix will disappear since there is no pathway between vectors and so no coupling.

In general each term in the backwards coupling matrix is a quotient of two dimensionless units,  $\varepsilon$  and  $\eta$ . The dispatch factor  $\varepsilon$  denotes the portion of the total load that is supplied by the energy carrier via a converter. For example,

$$\varepsilon_{P_x \rightarrow L_y}^{K_n}$$

would denote the portion of load  $L_y$  supplied by carrier  $P_x$  via converter  $K_n$ .

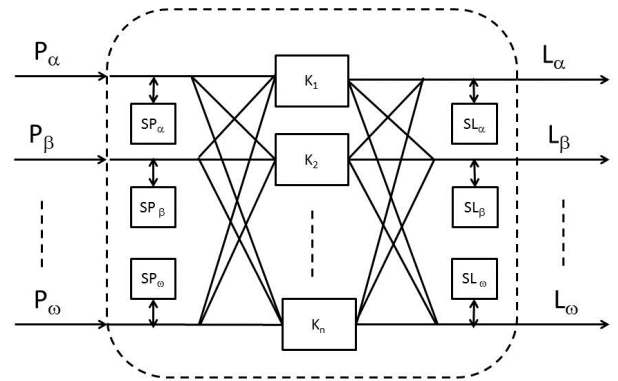

Figure 2. A fully connected energy hub with  $n$  converters,  $K_1 - K_n$  and storage on the input ports  $SP_\alpha - SP_\omega$ , and on the output ports  $SL_\alpha - SL_\omega$ .

### III. OPTIMISATION ALGORITHM

$\eta$  is the efficiency of each converter and must be written with subscripts to denote the energy it is converting, for example,

$$\eta_{P_x \rightarrow L_y}^{K_n}$$

is the efficiency of converter  $K_n$  when converting load  $P_x$  to load  $L_y$ . Equation (2) may be multiplied out where the first term is a way of expressing supply  $P_\alpha$  in terms of all the load vectors.

$$P_\alpha = \left( \frac{\mathcal{E}_{P_\alpha \rightarrow L_\alpha}^{K_1}}{\eta_{P_\alpha \rightarrow L_\alpha}^{K_1}} + \frac{\mathcal{E}_{P_\alpha \rightarrow L_\alpha}^{K_2}}{\eta_{P_\alpha \rightarrow L_\alpha}^{K_2}} + \dots + \frac{\mathcal{E}_{P_\alpha \rightarrow L_\alpha}^{K_n}}{\eta_{P_\alpha \rightarrow L_\alpha}^{K_n}} \right) L_\alpha + \left( \frac{\mathcal{E}_{P_\alpha \rightarrow L_\beta}^{K_1}}{\eta_{P_\alpha \rightarrow L_\beta}^{K_1}} + \frac{\mathcal{E}_{P_\alpha \rightarrow L_\beta}^{K_2}}{\eta_{P_\alpha \rightarrow L_\beta}^{K_2}} + \dots + \frac{\mathcal{E}_{P_\alpha \rightarrow L_\beta}^{K_n}}{\eta_{P_\alpha \rightarrow L_\beta}^{K_n}} \right) L_\beta + \dots \left( \frac{\mathcal{E}_{P_\alpha \rightarrow L_\omega}^{K_1}}{\eta_{P_\alpha \rightarrow L_\omega}^{K_1}} + \frac{\mathcal{E}_{P_\alpha \rightarrow L_\omega}^{K_2}}{\eta_{P_\alpha \rightarrow L_\omega}^{K_2}} + \dots + \frac{\mathcal{E}_{P_\alpha \rightarrow L_\omega}^{K_n}}{\eta_{P_\alpha \rightarrow L_\omega}^{K_n}} \right) L_\omega \quad (3)$$

There exist similar equations for each energy carrier down to  $P_\omega$ .

Now consider energy storage technology, shown in the generic hub in Fig. 2, with storage technologies positioned at both the input ports or the output ports. The behavior of storage must be considered in the time domain. In each time step the flows may change resulting in a changing level of energy in each storage and affecting the overall flow through the hub.

With the addition of the vector of storage flows on the load side of the hub  $\underline{SL}$ , and  $\underline{SP}$ , the vector of storage flows on the supply side, (2) becomes

$$\underline{P} = \underline{D}(\underline{L} + \underline{SL}) + \underline{SP} \quad (4)$$

Where for storages charging,

$$\underline{SL} > 0 \quad \text{and} \quad \underline{SP} > 0$$

for storages discharging,

$$\underline{SL} < 0 \quad \text{and} \quad \underline{SP} < 0$$

for storages on standby,

$$\underline{SL} = 0 \quad \text{and} \quad \underline{SP} = 0$$

It is clear from the previous section that for the energy hub containing storage and time dependent loads, its flows must be optimized for each time step. Each individual time step will add up to a total time horizon, over which the minimum total hub cost must be found. The behavior of storage must be considered over this entire time window. The following section describes a method of achieving this.

Loads for the entire time window are required in advance, which may be predicted with a reasonable degree of accuracy with a combination of weather and occupancy prediction.

First it is necessary to determine, for each time step, a backwards coupling matrix that meets the loads with the lowest cost without exceeding the maximum power of each converter. This is dependent on the price and emissions multipliers and the availability of renewable resources. A proxy variable known as ‘‘cost’’ is chosen to represent both price and emissions factor of one unit of each supply. (The normalized price and normalized emissions factor are calculated by dividing each price in that time step by the sum of all supply prices). These normalized values can then be weighted as desired and averaged to produce a proxy for each supply known as ‘‘cost’’. In this paper, emissions and price were weighted equally. From here, a merit order of hub converters for each load is obtained from the unit cost divided by the converter efficiency. Dispatch factors  $\mathcal{E}$  should then be chosen to route the flows through the converters according to the merit order, i.e. the most cost efficient converters are loaded first up to their maximum power, followed by the next most cost efficient and so on. If all the loads can be met with the most efficient converters for each load type, this time step is referred to as ‘‘unconstrained’’. If a lesser cost efficient converter is used, it is referred to as ‘‘constrained’’.

Secondly, storage flows must be calculated for each time step. Storage is only charged when the hub is in a unconstrained time step, such that the flows *plus the storage flows* are the maximum that the hub will allow without becoming constrained. If the hub is constrained, storage is set to discharge in an attempt to reach the unconstrained condition. This ensures as much as possible that the lowest cost converters are used to meet loads. Storages cannot exceed their maximum flow rates and are subject to standby losses and a charging and discharging efficiency penalty. In addition, storage may not be discharged when storage levels are empty or charged when full.

### IV. REAL TIME PRICING

As mentioned earlier, one of the benefits of storage can be cost avoidance. This is only possible against a dynamically varying tariff for at least one of the hub’s energy supplies, differentiating periods of high-cost energy supply from those of low-costs. The present electricity tariff structures in the UK are however mainly flat and 2-rate tariffs, they are not sufficiently dynamic to reflect the variation and uncertainties in the supply system. Real-time price (RTP) is the most direct way of reflecting dynamics of wholesale energy price [4] as they vary as a result of minute to minute change in load and

renewables, and price variations over time. The dynamics of RTP will allow the storage device in the energy hub to take advantage of lower energy prices, and mitigate purchase at high prices through the use of stored energy. RTPs are most common in the whole-sale energy market, reflecting the cost of energy generation. In this paper, RTPs are converted to real-time tariffs (RTT) to also reflect the cost of energy delivery, using the ratio between wholesale energy cost and transmission/distribution/retail costs [7].

The introduction of RTT into the “cost” proxy described in the previous section produces a time varying cost in both the electricity and gas supply, as shown in Fig. 3. This is because although the absolute price of gas is fixed, its normalized cost *relative* to electricity will change. In this paper solar energy has no associated price, (only a time independent emissions factor, due to lifecycle emissions) so its cost relative to the other supplies does not change. It is worth noting that although a fixed emissions factor was used here, this methodology could also handle a dynamic emissions factor, such as that caused by fluctuating levels of renewables in the electricity generation mix.

V. EXAMPLE OPTIMISATION

Fig. 4 shows an energy hub containing various conversion technologies and battery storage and a hot water tank connected to the output side electricity and heat ports respectively. Using the algorithm presented in section 3, the operation of this energy hub was optimized for four 24 hour periods, using scripts written in MATLAB 2012b. The key parameters of the converters and storages are in the appendix. These periods were single days in winter, spring, summer and autumn. Heat and electrical loads for these time periods were generated using software described in [8] and [9] respectively. The time step of the optimization was 30 minutes. The carbon dioxide equivalent factor of gas and electricity was based on values published by defra/DECC in 2012 [10], being 0.184 and 0.493 kgCO<sub>2</sub>/kWh respectively. The carbon emissions of solar energy was based on the

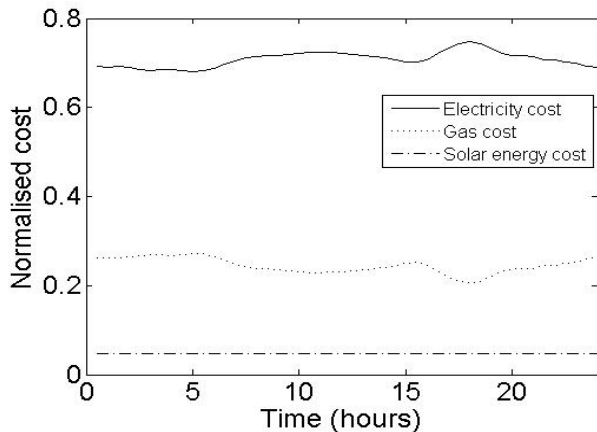

Figure 3. Time series of variation in costs.

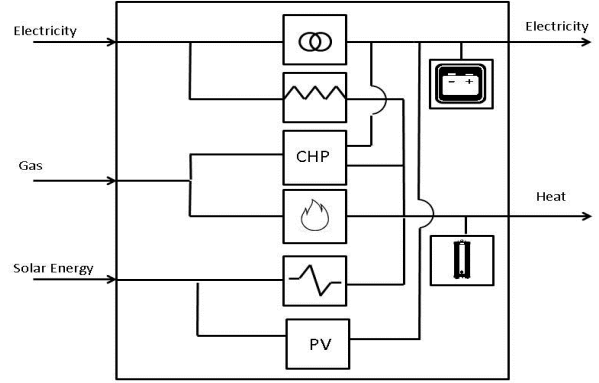

Figure 4. Hub optimized in example. Converters from top: transformer, electric heater, micro-CHP, gas boiler, solar heat exchanger, PV panels. Storage from top: battery and hot water tank.

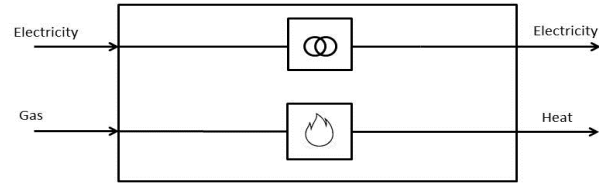

Figure 5. Base case energy hub (typical UK house).

average lifecycle equivalent CO<sub>2</sub> cost at 0.07 kgCO<sub>2</sub>/kWh. The maximum input power of the solar converters was their absolute maximum multiplied by the sunlight available, a factor between 1 at midday and 0 at midnight. The hub in Fig. 4 was compared to a base case energy hub, typical of a house in the UK, shown in Fig. 5, under the same real time tariffs. Fig. 6 shows the 24 hour time series over the day in winter of the optimized hub’s inputs against demand and storage levels. The time series of other seasons are omitted for brevity.

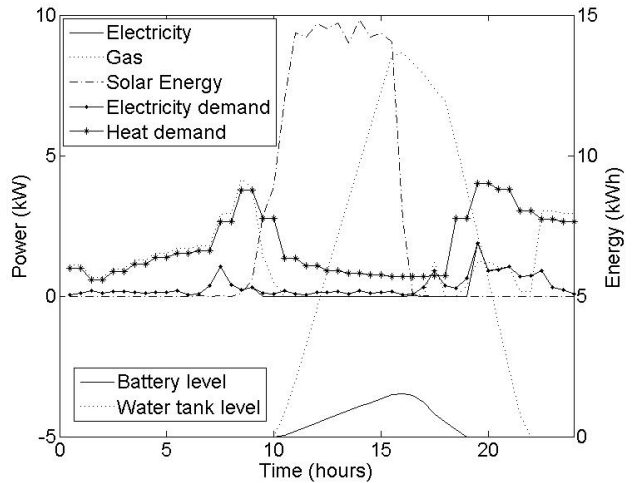

Figure 6. Winter: this shows the time series of the supplies consumed against the demand for a typical 24 hour period in winter. The storage energy levels are also plotted against the right hand y-axis.

Table 1 shows the annual savings compared against the base case. Annual savings were calculated by assuming each seasonal day represented a typical day, and multiplying each of the four 24 hour costs by 91, the average number of days per season. When managed with the algorithm presented here against the base case, the energy hub in Fig. 6 is able to make annual savings of £635 (60%) and 1025 kgCO<sub>2</sub> equivalent (25%).

## VI. CONCLUSION

An algorithm has been presented to manage domestic energy hub storage taking advantage of real time dynamic tariffs, resulting in 60% annual cost savings and 25% carbon savings. Although pure cost savings are unlikely to pay for the storage and converter infrastructure over its lifetime, if the emissions savings can be monetized and the ancillary functions of storage are leveraged, for example network support, this may well yield a positive investment case – although this is an area for further work. Also, applying a penalty lifecycle price and emissions factor to the converters and storage is an important future improvement to the algorithm.

TABLE I. SEASONAL AND ANNUAL EMISSIONS AND COST SAVINGS

	Base Energy Hub		Optimised Energy Hub with storage	
	Price (UK £)	Emissions (kgCO <sub>2</sub> equivalent)	Price (UK £)	Emissions (kgCO <sub>2</sub> equivalent)
Winter day	3.49	14.3	1.97	11.61
Spring day	3.18	12.01	1.3	10.99
Summer day	2.03	7.18	(storage surplus)-0.86	1.9
Autumn day	2.91	10.88	1.37	8.61
Annual Total	1057	4038	422	3013
		<b>Annual saving on base</b>	<b>635 (60%)</b>	<b>1025 (25%)</b>

## VII. APPENDIX: CONVERTER AND STORAGE DATA

Converter	Output Electrical Efficiency (%)	Output Heat Efficiency (%)	Maximum Input Power (kW)
Transformer	97	Null	10
Electrical Heater	Null	90	5
Micro-CHP	30	60	8
Gas boiler	Null	90	30
Solar Heat Exchanger	Null	70	5
Photo Voltaics	15	Null	2

Storage	Capacity (kWh)	Discharging Efficiency (%)	Charging Efficiency (%)	Standby Losses % of level per Δ t
Battery	20	60	60	$5.6 \times 10^{-5}$
Water Tank	30	90	90	$1.32 \times 10^{-3}$

## ACKNOWLEDGMENT

The authors gratefully acknowledge the support of the Department of Electrical Engineering, University of Bath, UK.

## REFERENCES

- [1] UK Government, (2011) *The Carbon Plan*, Department of Energy and Climate Change, London, UK, [Online]. Available: [https://www.gov.uk/government/uploads/system/uploads/attachment\\_data/file/47613/3702-the-carbon-plan-delivering-our-low-carbon-future.pdf](https://www.gov.uk/government/uploads/system/uploads/attachment_data/file/47613/3702-the-carbon-plan-delivering-our-low-carbon-future.pdf)
- [2] I. MacLeay, K. Harris and A. Annet, (2013) *Digest of UK Energy Statistics (DUKES)*, Department of Energy & Climate Change, London, UK, [Online] Available: <https://www.gov.uk/government/publications/digest-of-united-kingdom-energy-statistics-dukes-2013-printed-version-excluding-cover-pages>
- [3] Wang, Z. Gu, C. Li, F. Bale, P and Sun, H., "Active Demand Response Using Shared Energy Storage for Household Energy Management", *IEEE Tran. on Smart Grid*, vol.4, no.4, pp. 1888 – 1897, Dec. 2013.
- [4] Z. Wang and F. Li, "Developing trend of domestic electricity tariffs in Great Britain". *Unpublished, Presented at 2011 2nd IEEE PES International Conference and Exhibition on Innovative Smart Grid Technologies (ISGT Europe)*, 5-7 December 2011.
- [5] M. Geidl, "Integrated Modelling and Optimisation of Multi-Carrier Energy Systems," PhD dissertation, Power Systems Laboratory, ETH Zurich, Zurich, 2007.
- [6] E. Fabrizio, "Modelling of multi-energy systems in buildings," PhD, Politecnico di Torino, 2008.
- [7] OFGEM, (2013) *Electricity and Gas Supply Market Indicators*, [Online] Available: <https://www.ofgem.gov.uk/gas/retail-market/monitoring-data-and-statistics/electricity-and-gas-supply-market-indicators>
- [8] I. Richardson, M. Thomson, D. Infield, and C. Clifford, "Domestic electricity use: A high-resolution energy demand model," *Energy and Buildings*, vol. 42, pp. 1878-1887, 2010.
- [9] R. Yao and K. Steemers, "A method of formulating energy load profile for domestic buildings in the UK," *Energy and Buildings*, vol. 37, pp. 663-671, 2005.
- [10] UK Government, (2012) *2012 Guidelines to Defra/DECC's GHG Conversion Factors for Company Reporting: Methodology Paper for Emission Factors*, Department for Environment Food and Rural Affairs /Department of Energy and Climate Change, London, UK, [Online]. Available: [https://www.gov.uk/government/uploads/system/uploads/attachment\\_data/file/69568/pb13792-emission-factor-methodology-paper-120706.pdf](https://www.gov.uk/government/uploads/system/uploads/attachment_data/file/69568/pb13792-emission-factor-methodology-paper-120706.pdf)