



Citation for published version:

Cleasby, KG & Plummer, AR 2008, A novel high efficiency electro-hydrostatic flight simulator motion system. in Fluid Power and Motion Control (FPMC 2008). Centre for PTMC, UK, pp. 437-449.

Publication date:
2008

[Link to publication](#)

University of Bath

General rights

Copyright and moral rights for the publications made accessible in the public portal are retained by the authors and/or other copyright owners and it is a condition of accessing publications that users recognise and abide by the legal requirements associated with these rights.

Take down policy

If you believe that this document breaches copyright please contact us providing details, and we will remove access to the work immediately and investigate your claim.

A novel high efficiency electrohydrostatic flight simulator motion system

K G Cleasby

Thales Training and Simulation Ltd.

A R Plummer

Centre for Power Transmission and Motion Control
University of Bath

Abstract

Modern flight training simulators must be equipped with long stroke six degree-of-freedom motion systems that have high dynamic response. For many years electro-hydraulic actuators in a Stewart platform configuration have been found to best meet the performance requirements. However, valve-controlled actuators are very inefficient leading to a large power consumption, and also the need for a substantial cooling system to remove waste energy (heat) from the hydraulic oil. This paper describes a new design of motion system that uses a controlled brushless motor for each actuator, with power transmission via directly driven pumps to conventional simulator hydraulic cylinders. Accumulators are used to store and later recycle high pressure oil when actuators retract. In this way, power consumption has been dramatically reduced (for example from 45kW to 5kW during one representative motion waveform), while retaining the proven characteristics of the cylinder drive. Power consumption is lower, by a factor of between 2 and 4, than an equivalent all-electric solution. The motion system will be supplied for the first time with Boeing 787 simulators to be delivered in 2008. Design details are given in this paper, together with predicted and measured power consumption during a variety of representative cyclic motions.

1 INTRODUCTION

Flight training simulators, such as that shown in Figure 1, save the airlines significant amounts of money as pilots can be trained throughout the day, in safety and without risk of damage to the real aircraft. At most major airports the demand for take-off slots exceeds supply, but using simulators allows pilots to practice taking off and landing at a virtual re-creation of the airport without causing associated environmental damage and nuisance.

Pilot training involves creating the feel of how an aircraft will respond during each manoeuvre so that adjustments to the controls produce the correct feedback to the pilot. The best quality feel is achieved when such training simulators include a motion system that can reproduce the required motion cues produced by the aircraft in flight.



Fig. 1 Full flight training simulator

Motion systems require a good dynamic performance, large range of movement, and they need to be exceptionally smooth. As described in the next section, valve-controlled electro-hydraulic actuation has become accepted as the best way of meeting these challenging requirements. However valve-controlled systems consume a large amount of power, which then needs to be removed in the form of waste heat. This paper describes an alternative design which exhibits significant power saving. The new system is being supplied with the first Boeing 787 Dreamliner simulators.

2. CONVENTIONAL MOTION SYSTEM TECHNOLOGY

Stewart first proposed the use of a triangulated hexapod design for flight simulation in 1965 [1]. In this mechanism (Figure 2) each of the six legs can be extended or retracted to provide simultaneous movement in any of the 3 translational or 3 rotational degrees-of-freedom (DOF). The Stewart platform was first used for commercial flight simulators in the 1970's, replacing other designs with more limited DOF [2].

In the majority of commercial systems, long stroke hydraulic jacks are each driven by their own servovalve, supplied by oil at a fixed pressure from a large hydraulic power unit (HPU) – see Figure 3. This HPU is housed in its own substantially built acoustic room to prevent noise from interfering with training, and incorporates a sizeable water cooling unit. As an example, the Thales simulator HPU includes two 55kW electric motors each driving a variable displacement pump. The pump for circulating chilled water requires an additional 10kW.

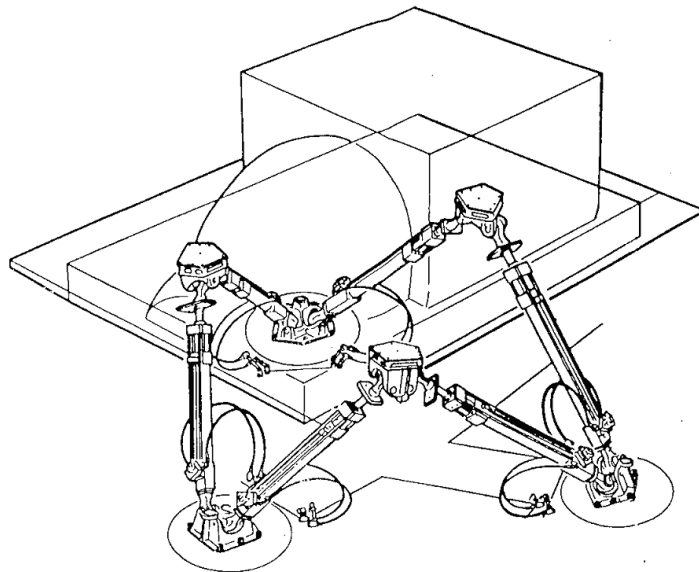

Fig. 2 Stewart platform motion system

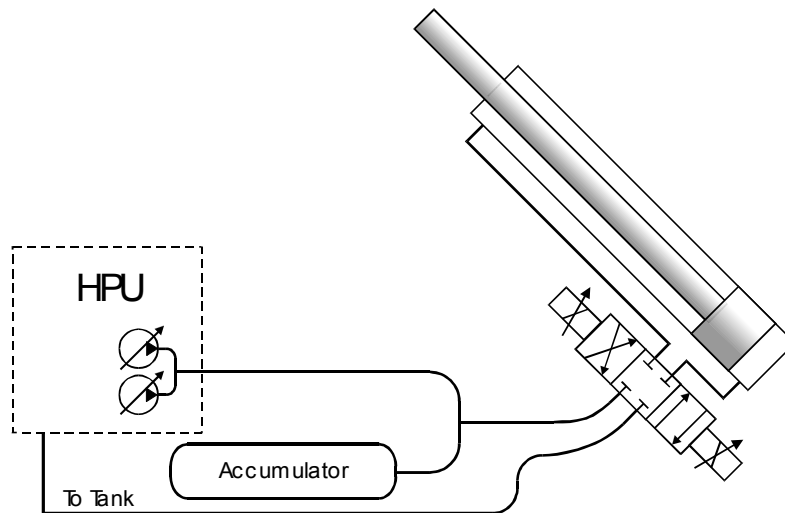

Fig. 3 A conventional valve-controlled hydraulic jack

3. NEW ELECTROHYDROSTATIC MOTION SYSTEM DESIGN

To reduce power consumption a new concept for driving the motion system jacks has been developed. The concept uses a coupled pair of fixed displacement pumps as shown in Figure 4. The pumps are driven by a 3-phase synchronous brushless servomotor. The servomotor is controlled in closed-loop using jack position feedback. By using two identical pumps on one shaft the flow pumped into the bottom of the jack is double the flow taken from the top of the jack. As the jack has been designed with a 2:1 area ratio the net flow

into the top (rod side) accumulator is theoretically zero, and its pressure remains constant. Sufficient pressure must be available on the rod side to generate the tensile loads required to support the platform in certain extreme positions.

The lower accumulator shown in Figure 4 provides a static pressure that counterbalances the weight of the simulator. It must also oppose the additional force resulting from the pressure in the rod side of the jack. With the correct choice of pressures to suit the weight of the simulator the net static torque on the electric motor can be very low. As the platform descends half of the flow from the head side of the jack is pumped into the lower accumulator. This causes the pressure in the lower accumulator to increase, but also the jack angle to the vertical will increase so that a greater load is placed on each jack, maintaining a better counterbalance throughout the vertical platform travel.

When the simulator is pitched or rolled to a static position there will be a larger unbalanced pressure drop across the pump. In this state the drive motor will have to provide a torque to oppose the pump torque and prevent rotation. Thus the motor needs to provide a static torque without using significant electrical power.

The extra efficiency compared to the conventional hydraulic system is obtained from two main factors:

1. Firstly the hydraulic counterbalance keeps the motor torque to a minimum when operating around mid stroke so that motor current is low and the associated copper losses are also low. The counterbalancing accumulators store and release energy associated which height changes, rather than this energy being dissipated.
2. Secondly the hydraulic part of the system does not restrict or meter the flow to provide control of velocity. Instead this comes from accurately controlling the speed of the electric motors that drive the hydraulic pumps.

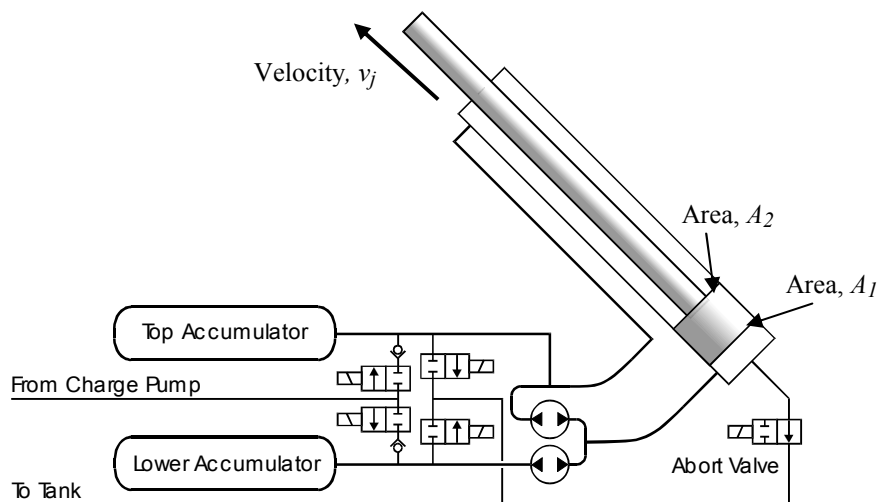

Fig. 4 New hydrostatic design

The concept of the electrohydrostatic actuator (EHA), i.e. linear motion control using a variable speed electrical drive via hydraulic transmission, is by no means new in other fields. EHA's are becoming commonplace for primary flight controls in aircraft (see e.g. [3]). Good performance is reported for an experimental gear-pump driven system in [4]. The design variant with a single-ended cylinder with accumulator energy storage is more unusual, but has been previously suggested as a way to save energy in mobile machines, in this case with the pump driven off the engine [5].

4. PREDICTION OF POWER CONSUMPTION IN A CONVENTIONAL VALVE-CONTROLLED MOTION SYSTEM

For the purposes of comparing power consumption, only sinusoidal motion in the heave (vertical) direction will be considered. For a valve-controlled system, the power consumption can be calculated using the supply pressure and the average rate at which fluid volume is consumed. Most flow is used in moving the piston, but some is continually lost via leakage, and when the flow requirement is less than that delivered by the minimum displacement of the pumps then there is an appreciable flow through the system relief valve.

Let the heave velocity be given by:

$$v_p = V_p \sin \omega t \quad (1)$$

A linearised conversion between platform heave and jack motion is given by using a simple scaling factor R:

$$v_j = RV_p \sin \omega t \quad (2)$$

To raise the platform the six servovalves connect the supply pressure to the head side of the jacks and connect the rod side to tank. They then reverse this connection to retract the jacks. The flow from the high pressure supply is given by the product of piston area and velocity, hence:

$$q = 6A_1RV_p \sin \omega t \quad \text{for} \quad \sin \omega t \geq 0 \quad (3)$$

$$q = 6A_2RV_p \sin \omega t \quad \text{for} \quad \sin \omega t < 0 \quad (4)$$

The average flow for all jacks is given by:

$$Q_{av} = \frac{1}{T} \int_0^T q \, dt \quad (5)$$

$$Q_{av} = \frac{1}{T} \int_0^{T/2} 6(A_1 + A_2)RV_p |\sin \omega t| \, dt \quad (6)$$

$$Q_{av} = \frac{6(A_1 + A_2)RV_p}{\pi} \quad (7)$$

where $T = 2\pi/\omega$. The total average power consumption is then:

$$\Psi_v = \frac{1}{\eta_v} \left(\frac{6(A_1 + A_2)RV_p P_s}{\pi} + \Psi_r \right) + \Psi_l \quad (8)$$

where P_s is the supply pressure, Ψ_l is a constant term representing water pump and leakage-related power loss, and Ψ_r is power loss through the relief valve (which is only significant when the jack flow requirement is below the minimum pump displacement), and η_v is the electric motor/pump efficiency. Thus for all but low velocities, the first term in equation (8) dominates and the power consumed is approximately proportional to the velocity amplitude.

5. PREDICTION OF POWER CONSUMPTION FOR NEW ELECTROHYDROSTATIC MOTION SYSTEM

5.1 Electrical drive considerations

In this application the motor and drive amplifier must accelerate and decelerate the platform. The actions required in this four-quadrant operation are shown in Figure 5. To operate in all four quadrants the drive amplifier must be able to force the motor current in either direction regardless of the direction of rotation. The electronic configuration required to perform this is shown in simplified form in Figure 6. In Figure 6(a) the direction of the output torque and hence current is the same as the direction of rotation and hence the back EMF (electro-motive force) opposes the DC supply voltage. This corresponds to the situation in quadrants 1 and 3, where there is electrical power input via the motor to the motion system. In Figure 6(b) the direction of the output torque and hence the current are in the opposite direction to the direction of rotation. This corresponds to the situation in quadrants 2 and 4 in which the platform mass is losing its kinetic energy. Hence the current must be reversed compared to quadrants 1 and 3 but the back EMF due to rotational speed has not reversed. Under these conditions the motor is acting as a generator and the kinetic energy is put back into the drive amplifier supply. However, in this application it is not feasible for the drive amplifier capacitors to store all the large amount of power generated during braking and the excess power is dissipated using large resistors.

4 Acceleration + Velocity -	1 Acceleration + Velocity +
3 Acceleration - Velocity -	2 Acceleration - Velocity +

Fig 5. Four Quadrant Operation

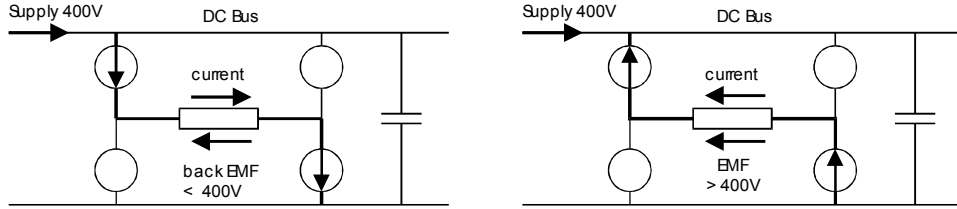

(a) Electrical power to motor (b) Electrical power from motor (regeneration)

Fig 6. Full bridge motor drive

In the following calculations it will be assumed that the power generated in quadrants 2 and 4 cannot be recovered. In practice there is some power generated by the motor in these quadrants but this approximately balances other losses which are not considered. Thus only the power taken from the supply in quadrants 1 and 3 will be included in the calculations.

5.2 Power consumed for platform acceleration

As previously stated the weight of the simulator is counterbalanced by the charge in the hydraulic accumulators and there is no static load on the electric motors. The power consumed is that required to accelerate the platform, and the net power during deceleration (braking) is assumed to be zero. Hence the instantaneous power consumption given by the product of inertial force and velocity is:

$$\psi = M\dot{v}_p v_p \quad \text{for } \dot{v}_p v_p \geq 0 \quad (9)$$

$$\psi = 0 \quad \text{for } \dot{v}_p v_p < 0 \quad (10)$$

where M is the platform mass. Note that:

$$\dot{v}_p v_p = V_p^2 \omega \sin \omega t \cos \omega t \quad (11)$$

$$\dot{v}_p v_p = \frac{V_p^2 \omega}{2} \sin 2\omega t \quad (12)$$

Thus the average acceleration power is:

$$\Psi_a = \frac{1}{T} \int_0^T \psi \, dt \quad (13)$$

$$\Psi_a = \frac{MV_p^2 \omega}{2\pi} \quad (14)$$

Note that the inertia of motors and pumps will also be significant, and this should be determined as an effective mass referred to the platform and included in M .

5.3 Power consumption resulting from pressure losses

The main power losses in the hydraulic part of the system are the result of pressure losses in manifolds and pipework. The pressure loss is assumed to be proportional to the square of the flow rate. The losses on the head and rod side respectively are:

$$|\Delta p_1| = K_1 (A_1 v_j)^2 \quad (15)$$

$$|\Delta p_2| = K_2 (A_2 v_j)^2 \quad (16)$$

The instantaneous power loss for each jack is:

$$\psi_j = |\Delta p_1 A_1 v_j| + |\Delta p_2 A_2 v_j| \quad (17)$$

or

$$\psi_j = K |v_j|^3 \quad (18)$$

where

$$K = K_1 A_1^3 + K_2 A_2^3 \quad (19)$$

Using equations (2) and (18), the average power associated with pressure losses for all six jacks is:

$$\Psi_p = \frac{6}{T} \int_0^T KR^3 V_p^3 |\sin \omega t|^3 dt \quad (20)$$

$$\Psi_p = \frac{8KR^3}{\pi} V_p^3 \quad (21)$$

5.4 Total Power Consumption

In addition to the acceleration and pressure loss powers, due to inexact counterbalancing of platform weight there is another power demand which is still present when the platform is stationary. This quiescent power (Ψ_q) is assumed to be constant. Thus the total power requirement is:

$$\Psi_e = \frac{1}{\eta} (\Psi_a + \Psi_p) + \Psi_q \quad (22)$$

$$\Psi_e = \frac{1}{\eta_e} \left(\frac{M\omega}{2\pi} V_p^2 + \frac{8KR^3}{\pi} V_p^3 \right) + \Psi_q \quad (23)$$

where η_e is the motor drive / pump efficiency.

6 THEORETICAL AND EXPERIMENTAL POWER COMPARISON

6.1 Motion specification and predicted power consumption

To be approved for pilot training a flight simulator must have a motion performance in accordance with specifications provided by the regulatory authorities. Some requirements

relating to vertical motion are given in Table 1. Sinusoidal motion is assumed for this study. In normal training the simulator motion will rarely reach these amplitudes and consequently half the amplitudes specified will be used for comparing the power consumption (shown in the final column in Table 1, and Figure 7).

The parameters of the conventional and new motion systems which are compared in this paper are given in Table 2. Using these parameters, and equations (8) and (23), the power consumption of the two systems is compared in Figure 8.

Vertical Performance	Federal Aviation Authority (FAA) proposed requirements	Half amplitude requirements used for power calculations
Acceleration	+/- 0.80 g	+/- 0.4 g
Velocity	+/- 0.610 m/s	+/- 0.305 m/s
Amplitude	+/- 0.864 m	+/- 0.432 m

Table 1. Motion specification

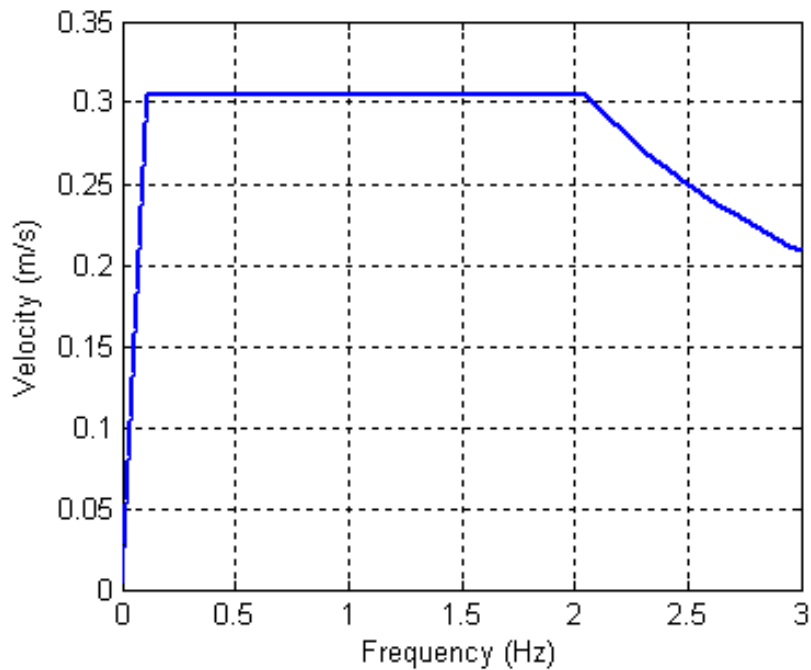

Fig 7. Half FAA vertical performance envelope

Platform / jack parameters		Comments
Piston head area, A_1	86.6 cm ²	
Piston rod-side area, A_2	42.4 cm ²	
Jack over vertical motion ratio, R	0.787	
Conventional valve-controlled jack		
Supply pressure, P_s	117 bar	
Water pump / leakage power, Ψ_l	10 kW	
Relief valve power loss, Ψ_r	≤ 8.5 kW	Maximum when static, rapidly becoming small with rising velocity
Drive/pump efficiency, η_v	0.85	
New electrohydrostatic system		
Quiescent power loss, Ψ_q	4 kW	
Head side pressure loss coefficient, K_1	6.19×10^{10} m ⁵ /(s ² N)	Gives 22bar loss at 0.48m/s jack velocity
Rod side pressure loss coefficient, K_2	2.66×10^{11} m ⁵ /(s ² N)	Gives 22bar loss at 0.48m/s jack velocity
Effective platform Mass, M	27 400 kg	Includes 11 400kg drive/pump inertia referred to platform
Drive/pump efficiency, η_e	0.85	

Table 2. System parameters

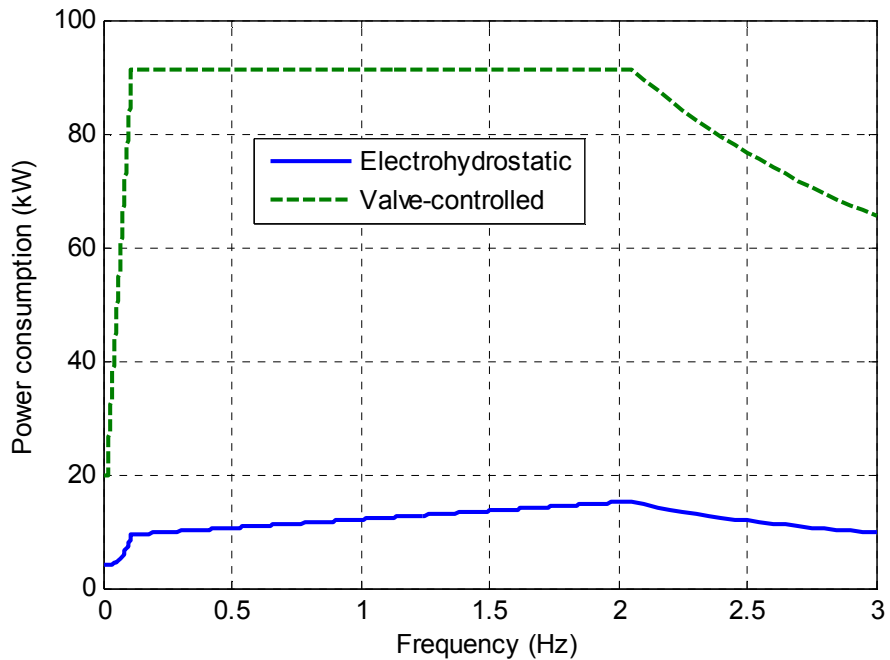

Fig 8. Comparison of Predicted Power Consumption (half FAA amplitude)

Note that the minimum power consumption for the valve-controlled system is 20kW, which is the measured consumption when the platform is not moving. This power is a combination of leakage losses and power required to drive the water circulation pump (together assumed to be a constant 10kW), and the minimum displacement of the variable displacement pumps meaning that flow is driven through the relief valve in this condition.

6.2 Measured power consumption for electrohydrostatic motion system

To confirm the calculation method power consumption tests were performed on both systems and the results compared to the predicted values. To perform the tests a 3-phase wattmeter was connected to the mains supplying the drive amplifiers of the electrohydrostatic system and to the HPU supply for the hydraulic system.

Averages over time were taken while static and while moving at a single frequency using a sinusoidal waveform. The results for the electrohydrostatic system are given in Table 3. The predictions are reasonably consistent with the measured values. Note that at higher frequencies there may be more flow through the hydraulic system components than predicted due to compressibility of the working fluid.

6.3 Measured power consumption for valve-controlled system

Two tests were made on a conventional valve-controlled motion system. The results were for the static case and for motion at 0.2 Hz as shown in Table 4.

7. CONCLUSIONS AND DISCUSSION

It has been shown that the new electrohydrostatic drive system gives significant power savings with a variety of motion amplitudes and frequencies. It is difficult to predict an overall power saving when in general use as the type of training will change the duty cycle and magnitude of any motion. For example the magnitude of turbulence selected by the instructor will change the power consumption.

If a comparison were to be made at a single test frequency and amplitude then 0.2 Hz at 0.1016 m (4 inch) vertical amplitude as used in Tables 3 and 4 could be a good choice. In acceleration this equates to 0.16g and would be equivalent to a continuous gentle manoeuvre. Under this condition the servovalve-controlled motion platform requires 45 kW while the electrohydrostatic system requires 4.7 kW. It should be remembered that a typical flight training school may have around 10 simulators and hence if all simulators were running the electrical power saving could be around 0.4 MW.

Calculation of energy consumption in a valve-controlled hydraulic system with a fixed supply pressure can be computed with good accuracy provided the swept volume of fluid consumed is known. However the minimum power consumption of the variable displacement pumps and other HPU equipment must be included in any calculation.

Cyclic Frequency Hz	Platform Amplitude m	Calculated Acceleration Power kW	Calculated Pressure loss Power kW	Total Calc Power inc Quiescent kW	Measured Power kW
0.050	0.55372	0.049	0.947	5.00	5.34
0.126	0.18910	0.091	0.604	4.69	5.27
0.200	0.1016	0.105	0.374	4.48	4.70
0.200	0.18910	0.364	2.414	6.78	8.48
0.600	0.08255	1.870	5.422	11.3	12.6
1.000	0.06309	5.058	11.205	20.3	22.3
2.048	0.02660	7.723	7.214	18.9	17.3
3.000	0.01958	13.15	9.043	26.2	24.6
4.100	0.00658	3.792	0.876	8.67	8.55
6.000	0.00270	2.000	0.190	6.20	4.9
10.00	0.00060	0.458	0.010	4.47	4.6
30.00	0.00003	0.031	0.000m ²	4.03	4.1

Table 3 Predicted and measured power consumption – electrohydrostatic system

Cyclic Frequency Hz	Platform Amplitude m	Calculated Motion Power kW	Water pump / leakage power kW	Total Predicted Power kW	Measured Power kW
0	0	0	10	20	19.4
0.2	0.1016	34.1	10	44.1	44.64

Table 4 Predicted and measured power consumption – valve-controlled system

The power consumption in the electrohydrostatic system can be predicted with good accuracy by the consideration of three elements: the acceleration forces, the pressure loss and the quiescent consumption. When considering the acceleration forces the extent to which the amplifier DC bus system might be able to recover power during braking should be determined. Note that in this case, the DC bus for each drive has 1500 μ F of capacitance and can rise by 155V before power is dumped across resistors, giving a total (for all six) energy storage of 108J; thus a theoretical maximum regeneration of only 108W is possible for a 1Hz motion. There may be some future savings to be made by increasing the size of the capacitors on the DC bus or adding an inverter to put power back into the mains supply while the simulator is braking.

Further savings in power consumption may be possible by reducing the pressure loss within the hydraulic parts of the system. However as can be seen in Table 3 the 0.2 Hz 0.1016 m case absorbs very little pressure loss power and the cost of reducing this may not be justified by the savings during normal training.

It is highly likely that traditional valve-controlled hydraulic flight simulator motion systems will not be produced by the main manufacturers for much longer. As an alternative to the system described in this paper, an all-electric solution could be adopted in which each leg is driven by a brushless motor through a ball or roller screw. Power consumption for such a solution has been predicted at 10kW, compared with 40kW for a valve-controlled system under the same conditions, and in practice power consumption has been found to be between 25% and 50% of the traditional system [6]. The fact that the electrohydrostatic system consumes less power, by a factor of between 2 and 4, than the all-electric system is due to the energy storage capability of the former.

REFERENCES

1. Stewart, D. *A platform with six degrees of freedom*. Proc Instn Mech Engrs, Vol 180 Pt 1, No. 15, p371-378, 1965.
2. Rolfe J.M., Staples K.J. *Flight simulation*. Cambridge University Press, 1986.
3. Crowder, R., Maxwell, C. *Simulation of a prototype electrically powered integrated actuator for civil aircraft*. Proc Instn Mech Engrs Vol 211 Part G. p381-394, 1997.
4. Habibi, S., Goldberg, A. *Design of a New High Performance ElectroHydraulic Actuator*, IEEE/ASME Transactions on Mechatronics, Vol. 5, No. 2, pp 158-164, June 2000.
5. Rahmfeld, R., Ivantysynova, M. *Displacement Controlled Linear Actuator with Differential Cylinder - A way to save primary energy in Mobile Machines*. In: Proc. of the 5th Int. Conf. on Fluid Power Transmission and Control, Hangzhou, China, pp. 316-322, 2001.
6. Bartel, C, Foster, D *Life Cycle Motion Base Cost Comparison: Electric vs. Hydraulic*. Moog Inc Technical Paper.